

OPERATING NOTE 15 OCT 67

Handwritten notes:
 $\frac{11.5}{9.42} = 1.22$
 $\frac{13.2}{15.6} = 0.846$
 $\frac{2.9}{2.9} = 1$
 WORK
 11.5
 9.42
 13.2
 15.6
 2.9

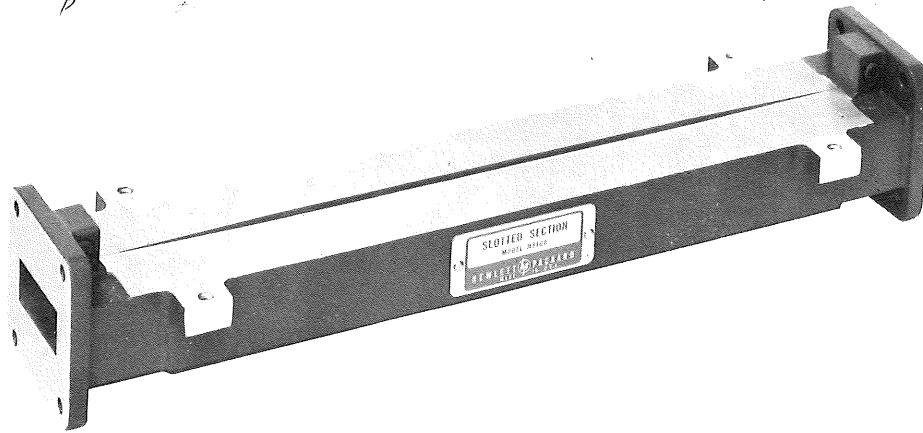

Figure 1. Model H810B Slotted Section

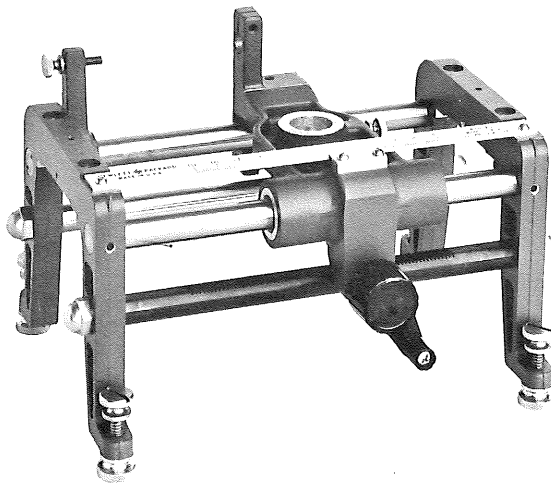

Figure 2. Model 809C Universal Probe Carriage

1. INTRODUCTION.

2. Model 810B slotted sections (Figure 1) are designed for use with the Model 809B/C Universal Probe Carriage

in slotted-line measurement systems. The 810B consists of an accurately machined waveguide section with a narrow longitudinal slot tapered to ensure low SWR; sections are available for measurements over the 3.95- to 18-Gc range.

3. PRINCIPLES OF OPERATION.

4. A Model 810B slotted section is installed in an 809C Universal Probe Carriage shown in Figure 2. In operation, RF power is applied through the slotted section to the device under investigation. The fields in the line are sampled by means of a probe which protrudes into the slotted section. The output of the probe is fed to a high-gain voltmeter such as the HP Model 415B/C Standing Wave Indicator. With this type of setup, information about variations along the entire length of probe travel can be obtained.

5. OPERATION.

6. See the Operating and Service Manual for the Model 809B/C Universal Probe Carriage for installation instructions.

Table 1. Specifications

Model	Frequency Range (Hz)	Waveguide I.D. (in.)	Fits Waveguide Size (inches) (EIA)		Equiv. Flange
G810B	3.95 - 5.85	1.872 ± 0.004 x 0.872 ± 0.002	2 x 1	WR187	UG-407/U
J810B	5.30 - 8.20	1.372 ± 0.002 x 0.622 ± 0.001	1-1/2 x 3/4	WR137	UG-441/U
H810B	7.05 - 10.00	1.122 ± 0.002 x 0.497 ± 0.001	1-1/4 x 5/8	WR112	UG-138/U
X810B	8.20 - 12.40	0.900 ± 0.002 x 0.400 ± 0.001	1 x 1/2	WR90	UG-135/U
M810B	10.0 - 15.0	0.750 ± 0.002 x 0.375 ± 0.001	0.850 x 0.475	WR75	
P810B	12.40 - 18.00	0.622 ± 0.001 x 0.311 ± 0.001	0.702 x 0.391	WR62	UG-419/U
Slope and irregularities: 1.0± SWR		Length: 10-1/4 inches (260 mm)			
Discontinuity due to slot results in SWR of less than 1.01		Carriage: Fits HP 809B/C Universal Probe Carriage			

00242-4

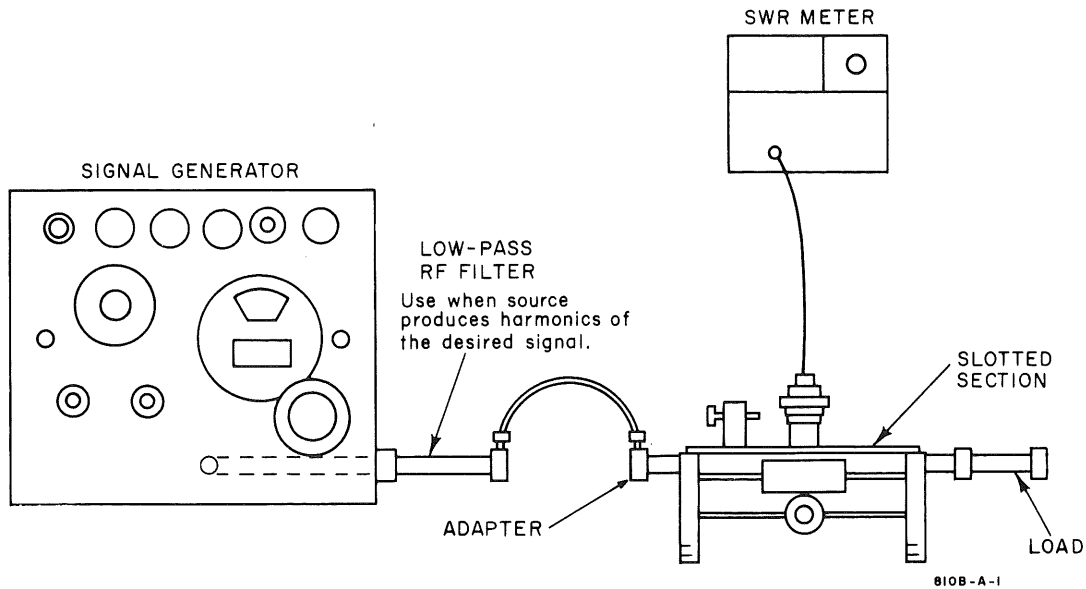

Figure 3. Setup for Measuring SWR

7. OPERATING PRECAUTIONS.

8. Protect the flanges from damage. Any scoring or burring of the mating surfaces causes discontinuity; the resulting increase in SWR degrades performance.

9. PERFORMANCE CHECK.

10. The following procedures check 810B performance for incoming inspection, periodic evaluation, calibration and troubleshooting. Specifications given in the specification table are the performance standards.

11. TEST EQUIPMENT REQUIRED.

12. Instruments and accessories required to make the performance tests are listed in Table 2. Test instruments other than the ones listed can be used provided performance equals or exceeds the critical specifications listed.

13. SLOPE AND IRREGULARITIES.

14. Connect the equipment as shown in Figure 3.

- Adjust probe depth about 1/8" less than maximum penetration.
- Set the signal generator for highest frequency of waveguide section with 1000-Hz squarewave modulation.
- Set the SWR meter to the -50 dB EXPAND scale.
- Adjust signal generator OUTPUT for an indication on the SWR meter.

e. Move the carriage through its full travel while observing amplitude variation in the peaks of the standing waves. If necessary, loosen socket-head capscrews slightly on end of carriage with the higher reading and tighten the slope adjustment screw (small hex socket-head setscrew at centerline of endframes). Continue this adjustment until variation is equal to or less than 0.2 dB. This is the slope adjustment.

f. Test at lowest frequency of waveguide section and intermediate frequencies. Variation must be equal to or less than 0.2 dB at all frequencies (without readjustment).

15. RESIDUAL SWR.

16. Measure the residual SWR at lowest frequency of waveguide section and intermediate frequencies as follows:

a. Adjust both the position of the probe carriage on the slotted section and the position of the sliding load to obtain the highest SWR. This adjustment requires some care since the settings are interdependent.

b. Set the SWR meter for a reading of 1.0 on the EXPANDED scale.

c. Move the carriage to a minimum and move the sliding load to obtain the minimum SWR reading on the SWR meter. Again this adjustment requires some care since these settings are also interdependent. This reading is the residual SWR. This value must be equal to or less than 1.01.

Table 2. Recommended Test Equipment

The following test equipment is recommended for performance testing of the Model 810B. Other equipment may be substituted provided it meets or exceeds the specifications in the Critical Specifications column.		
<u>Instrument</u>	<u>Critical Specifications</u>	<u>HP Model Number</u>
Signal Generator	Frequency: band of interest Modulation: 1000 Hz squarewave	618C (3.8 to 7.6 GHz) 620B (7 to 11 GHz) 626A (10 to 15.5 GHz) 628A (15 to 21 GHz)
Low-pass Filter	Passband: band of interest Reject: second harmonics	360D (cutoff 4.1 GHz) X362A (X-band) M362A (M-band) P362A (P-band)
Adapter (if needed)	Frequency: band of interest Coaxial to waveguide	281A
Carriage	Fits 810B	809C
Detector	Frequency: band of interest Fits 3/4" mounting hole	442B/444A/446B/447B (442B needs 440A Detector Mount also)
SWR Meter	Compatible with detector Expanded SWR scale	415B/E
Load	To fit waveguide	910A

Table 3. Performance Check Test Card

Model 810B	Date _____
Waveguide Slotted Section	Tested by _____
SWR _____ (≤ 1.01)	