

NOTE REGARDING FACTORY CALIBRATION PROCEDURES
AND TEST SPECIFICATIONS

Factory Calibration Procedures and Test Specifications are intended for use at the factory as a general guide for calibrators and quality control men. Most of the tolerances listed in these sheets are closer than advertised specifications. This is done purposely in order to insure that the instrument will meet or exceed advertised specifications when it reaches the customer.

These calibration procedures and test specifications should be used, therefore, as a guide only.

Some of the test equipment referred to in the calibration procedures is not available commercially; the Tektronix field engineer will be glad to suggest alternate approaches.

FIELD RECALIBRATION PROCEDURE

CONTENTS:

Introduction
Circuit specifications
Recal procedure
Certification procedure
Recal check sheet

INTRODUCTION:

This recalibration procedure is intended for Tektronix Field Repair Center use.

The specifications listed are factory specs and not guaranteed unless they also appear as catalog or instruction manual specs.

Special equipment has been kept to a minimum, depending on availability and recal time saved vs production, distribution cost and complexity.

The recalibration steps were designed to make the procedure as simple and as fast as possible, and yet complete enough for a first-time recalibration. To accomplish this, each step was arranged in two parts -- Setup and Adjustment; detailed setup procedures were replaced in many cases with general statements. Block diagrams or circuit diagrams were included in certain steps to help locate the adjustment and show what the adjustment does to produce the desired results to aid in troubleshooting. A simplified adjustment procedure was called out next to each adjustment on the block diagram or circuit diagram to help speed up the recal once a person becomes familiar with the instrument, and waveforms were shown where needed.

The blank column on the right of the page is for notes on troubleshooting hints and general information concerning the recal. It will be filled in as we receive feedback from the Field or further information from the factory.

The "Certification Procedure" shows what part of the instrument may be certified and what is required to perform the certification. Forms may be obtained from Customer Service.

A Recal check sheet has been included for those persons who have become familiar enough with the recal procedure to use it.

Since this procedure is for the Field, we hope all Field personnel will help us improve it. Address your communications to *Field Technical Support*. No suggestions will go unnoticed.

86

Publication:
061-590
September 1962



For all serial numbers.

ABBREVIATIONS:

a	amp	min	minimum
ac	alternating current	mm	millimeter
approx	approximately	mpt	metalized, paper tubular (capacitor)
b	base	msec	millisecond
bulb	light, lamp, etc.	mt	mylar, tubular (capacitor)
c	collector	mv	millivolt
ccw	counterclockwise or full counterclockwise	μ	micro (10^{-6})
cer	ceramic	μ f	microfarad
cm	centimeter	μ h	microhenry
comp	composition (resistor)	μ sec	microsecond
cps	cycles per second	n	nano (10^{-9})
crt	cathode ray tube	nsec	nanosecond
cw	clockwise or full clockwise	Ω	ohm
db	decibel	p	pico (10^{-12})
dc	direct current	pbt	paper, "bathtub" (capacitor)
div	division	pcc	paper covered can (capacitor)
e	emitter	pf	picofarad ($\mu\mu$ f)
emc	electrolytic, metal cased (capacitor)	piv	peak inverse voltage
fil	filament	pmc	paper, metal cased (capacitor)
freq	frequency	poly	polystyrene
gmV	guaranteed minimum value (capacitor)	pot	potentiometer
gnd	chassis ground	prec	precision (resistor)
h	henry	pt	paper, tubular (capacitor)
hv	high voltage	ptm	paper, tubular molded (capacitor)
inf	infinity	ptp	peak-to-peak
int	internal	sec	second
k	kilo (10^3)	sn	serial number
k	kilohm	term	terminal
m	milli (10^{-3})	tub	tubular (capacitor)
ma	milliamp	unreg	unregulated
max	maximum	v	volt
mc	megacycle	var	variable
meg	megohm	w	watt
mh	millihenry	WW	wire wound
mid r	midrange or centered	x-former	transformer

©, 1962, Tektronix, Inc., P. O. Box 500
Beaverton, Oregon. All rights reserved.

II CIRCUIT SPECIFICATIONS:

Factory circuit specifications are not guaranteed unless they also appear as catalog or instruction manual specifications. Factory circuit specs usually are tighter than advertised specs. This helps to insure the instrument will meet, or exceed, advertised specs after shipment and during subsequent field recalibrations over several years of use.

The numbers listed beside the specifications are the calibration procedure steps where the check or adjustment is made.

- 2c Output DC voltage above ground should be 50 volts ± 3 V.
- 3a Using X1 GAIN ADJ, Gain must be variable over the range of -5% to +10% of the proper setting.
- 5a With the X1 GAIN ADJ set properly, the X10 Gain Adj. pot (R356) must be variable over the range of $\pm 10\%$ of the proper setting.
- 6d No appreciable micro effects (especially ringing type) from operation of front panel controls (with GAIN at X10). Total noise on trace in X10 amplifier (input shorted) will not exceed 1 mm.
- 4c and 7b X1 and X10 POSITION RANGE controls must adjust within 90° of center of rotation.
- 3c Attenuator ratios must be held to $\pm 2\%$ on all ranges.
- 10a Total waveform distortion in X1 amplifier shall not exceed 1 trace width. This included overshoot, ringing, slope, etc., with 2 cm squarewave displayed.
- 11a Total waveform distortion in X10 amplifier shall not exceed $1/2$ mm with 2 cm square-wave displayed.
- 12d and 12c Frequency response of the X1 amplifier will be down no more than 3.5 db at 85 mcs.
- 13b Frequency response of the X10 amplifier will be down no more than 3.5 db at 80 mcs.

III TYPE 86 RECALIBRATION PROCEDURE:

RECALIBRATION

REPAIR NOTES

Equipment Required:

- 1 580 Series Oscilloscope
(Standardized-Calibrated)
- 1 Type 84 Plug-in Test Unit
- 1 Type 105 Square Wave Generator
- 1 Test Scope (530/540 Series or
equivalent)
- 1 Test Plug-in (Type G or equivalent
w/10 MV DC Sensitivity)
- 1 GR Oscillator 50-250 MC w/mod-
ified 190 or GR Power Supply
- 1 Type 190 Constant Amplitude
Signal Generator
- 1 Tunnel Diode Pulser (015-038)
- 1 VOM Triplett 630 or equivalent
20,000 Ω /volt, 3% accuracy
- 1 50 Ω Terminator, BNC (011-049)
- 1 12 pf Input Capacitance
Standardizer (011-051)
- 1 50 Ω 10:1 Atten. BNC (010-314)
- 1 50 Ω Cable RG58AU (012-001)
- 2 5 nsec 50 Ω Cable RG8AU (017-502)
- 1 Type BNC to UHF Adapter (103-032)
- 1 Type BNC to GR Adapter (017-064)
- 2 Type BNC to GR Adapter (017-022)
- 1 50 Ω 10:1 Atten. UHF (011-031)
- 2 874-VR (General Radio) (FMS)
- 1 50 Ω 10:1 Atten. GR (017-001)
- 1 Plug-in Extension (013-055)

The Vert. Gain of standardized 580 scopes should be adjusted for .1 V sensitivity with a TU-3 or Type 84 Test Load unit as compared to the old method of adjusting for .09 V sensitivity with a TU-3. If a standardized 580 scope is to be used with a Type 80/P80, the scope Vert. Gain must be re-adjusted since the P80CF gain is less than 1.

BASIC FRONT PANEL SETTING

Unless otherwise stated, each step should have the following front panel settings:

Type 581/585

HORIZ. DISPLAY -- INT. SWEEP (581)
-- "A" SWEEP (585)
TRIGGERING SOURCE -- INT.
TRIGGERING SLOPE -- +
STABILITY -- cw
TIME/CM -- 1 millisecc
5X MAGNIFIER -- OFF

Type 86

VERTICAL POSITION -- mid-range
VOLTS/CM -- 0.1
VARIABLE VOLTS/CM -- cw
X1 GAIN ADJ. -- cw
GAIN -- X1
X1 VERT. POS. RANGE -- mid-range
X10 VERT. POS. RANGE -- mid-range
AC-DC -- DC

RECALIBRATION

NOTES

1. COARSE ADJUSTMENT OF X1 POS. RANGE

- A. Setup
 - a) Basic settings.
- B. Adjustment
 - a) Adjust the trace to center graticule line with X1 POS. RANGE control.

2. DISTRIBUTED AMPLIFIER BIAS and TUBE BALANCE

- A. Setup
 - a) STABILITY control cw.
 - b) Short plug-in distributed amplifier grid lines together.
- B. Adjustment
 - a) Check grid bias of V524, V534 and V544 for minimum of .3 V.
 - b) Select tubes for overall balance within 1/2 cm of scope electrical center. (Record or remember scope elec. center -- will be used later)
 - c) Check output DC voltage to ground (50 V \pm 3 V)

To determine scope electrical center, use TU-3, 84 or short pins 14 and 16 of Amphenol connector.

3. X1 GAIN ADJ. and GAIN BAL. (R277)

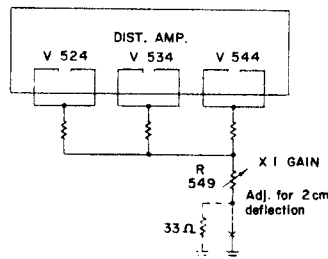

- A. Setup
 - a) Display .2 V calibrator signal, plug-in sens. .1 V/cm.
- B. Adjustment
 - a) X1 GAIN for 2 cm deflection.

Check scope gain for .1 V/cm with TU-3 or 84 plug-in.

In some cases it may be necessary to add R550 (33 Ω , 1/2 w. 10% resistor) from the X1 GAIN pot to ground to obtain proper range control of -5 to +10% of proper setting.

RECALIBRATION

NOTES

3. B. Adjustment (con'd)
 b) Check VOLTS/CM switch steps:

AMPLITUDE CALIBRATOR	VOLTS/CM SWITCH	DEFL.
.2 V	.1	2 cm
.5 V	.2	2.5 cm
1.0 V	.5	2 cm
2.0 V	1.0	2 cm
5.0 V	2.0	2.5 cm
10.0 V	5.0	2 cm
20.0 V	10.0	2 cm
50.0 V	20.0	2.5 cm

±2% tolerance on all ranges

- c) Check VAR. VOLTS/CM control for approximate 2:1 range.
 d) Check AC-DC switch for approx. 50% shift when switched to AC with calibrator waveform base line set to center graticule line.

4. X1 POSITION RANGE:

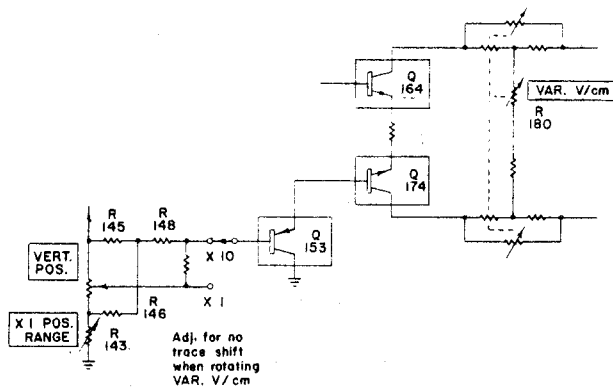

A. Setup

- a) Plug-in: GAIN -- X10
 VOLTS/CM -- 2
 b) Connect VOM between center arm of VERT. POS. control and junction of R145, R146 and R148. Set meter to lowest DC voltage range.

B. Adjustments

- a) Rotate VERT. POS. control to obtain OV reading.
 b) Loosen set screw on knob and reposition knob so white dot is at 12 o'clock.
 c) Adjust X1 POS. RANGE controls for minimum trace shift while rotating VAR. VOLTS/cm control. (Keep trace on graticule with X10 POS. RANGE control).

RECALIBRATION

NOTES

5. SET X10 AMPLIFIER GAIN:

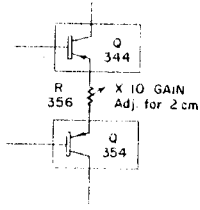

- A. Setup
- Plug-in: VOLTS/cm --
0.01
 - Apply 20 millivolts CAL signal to the input.
- B. Adjustments
- A X10 Gain (R356; Int.) for 2 cm deflection.

6. GAS AND MICHROPHONICS:

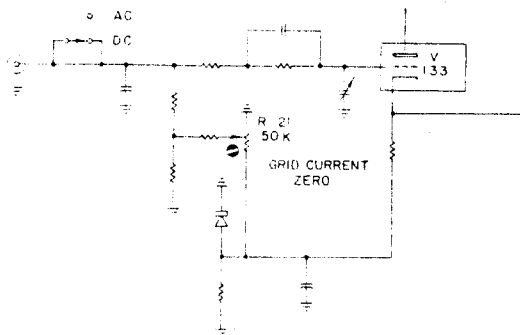

- A. Setup
- Plug-in: X10 GAIN --
.01 V/CM
 - Ground input at the input connector.
 - Set Grid Current Zero control (R121) fully cw (located upper midway of chassis).
- B. Adjustment
- Switch AC-DC switch from DC to AC and observe trace shift. (.5 cm max.)
 - Adjust Grid Current Zero (R121) for no trace shift when switching between DC and AC.
 - Check for micro effects and noise.

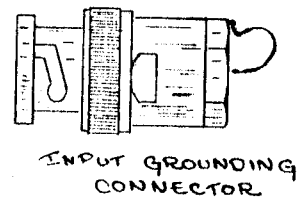

Typical micro effect from operation of front panel controls 2 mm. Total noise on trace in X10 amplifier (input grounded) should not exceed 1 mm.

RECALIBRATION

NOTES

7. SET X10 POSITION RANGE:
 - A. Setup
 - a) Recheck X1 POS.RANGE ADJ. (Step 4). Do not alter setting of VERT.POS. control for remainder of this step.
 - B. Adjustment
 - a) Adjust the trace to the scope elec. center with X10 POS. RANGE controls.
 - b) Switch GAIN to X1 and observe trace shift. (Max .5 cm from scope electrical center)

8. ADJUST INPUT CAPACITOR:

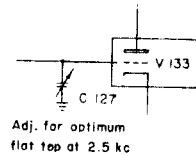

- A. Setup
 - a) Plug-in: GAIN - - - X1
 - b) Apply 2.5 KC sq.wave signal from 105 to the input through 10:1T pad and 12 pf cap. standardizer.
 - c) Adjust 105 Amplitude for 3 cm deflection.
- B. Adjustment
 - a) Adjust input capacitor for optimum flat top (C127; see Layout, Step 9).

9. VOLTS/CM SWITCH COMPENSATION:
 - A. Setup
 - a) Plug-in: Same as Step 8. VOLTS/CM switch as indicated in table.
 - b) Scope: Triggered display.
 - B. Adjustments

VOLTS/CM SWITCH	ADJ. for OPT. SQ.CORNER	ADJ. for OPT. FLAT TOP
0.2 - - -	C103C - - -	C103B - - -
0.5 - - -	C105C - - -	C105B - - -
1.0 - - -	C107C - - -	C107B - - -
2.0 - - -	C109C - - -	C109B - - -
5.0 - - -	C111C - - -	C111B - - -
10.0 - - -	C113C - - -	C113B - - -
20.0 - - -	C115C - - -	C115B - - -

RECALIBRATION

NOTES

9. B. Adjustments (con'd)

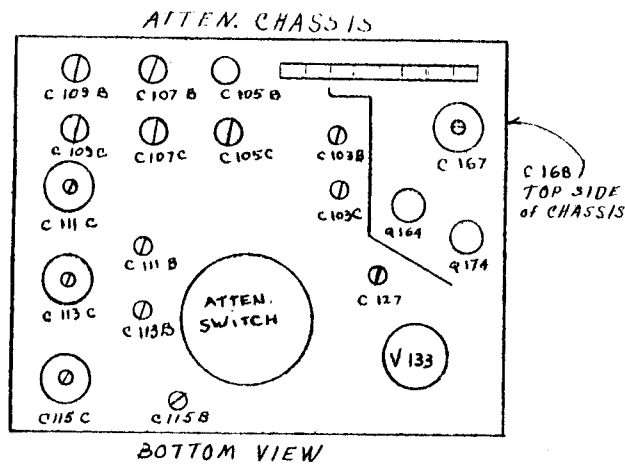

10. X1 HIGH FREQUENCY COMPENSATION:

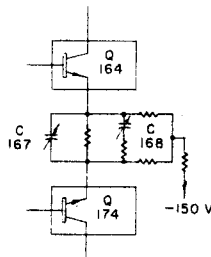

A. Setup

- a) Plug-in: VOLTS/CM -- .1
GAIN -- X1
- b) Scope: TIME/CM -- .5
millisec
- c) Connect Tunnel Diode pulser to the INPUT through 50 Ω BNC Terminator (TEK 011-049).
- d) Connect 100 V CAL signal to Tunnel Diode pulser.
- e) Adjust Tunnel Diode bias control slightly past the firing point.
- f) Adjust TRIG. LEVEL for stable display then increase TIME/CM to .05 μ sec.

B. Adjustment

- a) Adjust C167, C168 and C524 for optimum square wave response. (Distortion less than \pm one trace width with 2 cm deflection).

Refer to layout, Step 9, for C167 and C168 locations; C524 located over V524 tube socket.

RECALIBRATION

NOTES

11. X10 HIGH FREQUENCY COMPENSATION:

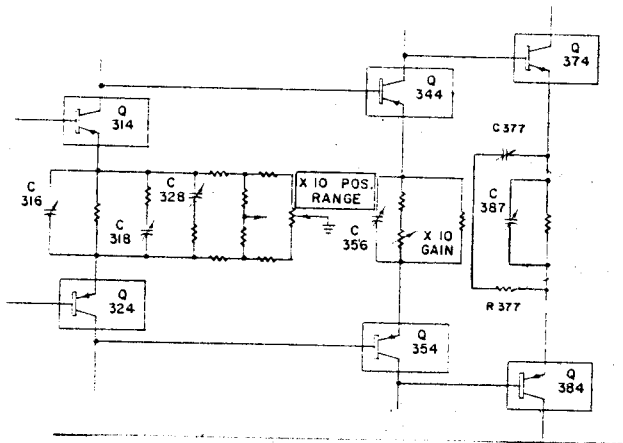

- A. Setup
 - a) Same as Step 10 except GAIN to X10 and 50 Ω 10:1 Attenuator (TEK 010-314) between Tunnel Diode pulser and 50Ω Terminator and remove plug-in extension.
- B. Adjustment
 - a) Adjust C316, C318, C328, C356, C377 and C387 for optimum sq. wave response. (Distortion less than ±1/2 mm with 2 cm deflection).

SIDE VIEW X10 AMPLIFIER

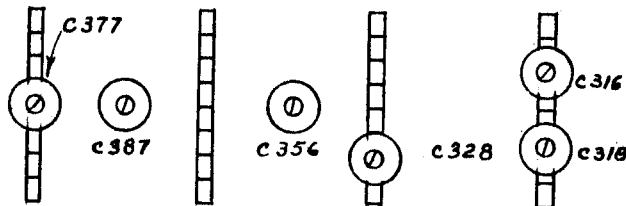

12. X1 BANDPASS MEASUREMENT:

- A. Setup
 - a) Plug-in: VOLTS/CM -- 0.1
GAIN -- X1
 - b) Scope: Free-run sweep

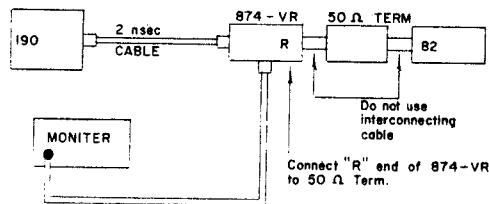

RECALIBRATION

NOTES

12. A. Setup (con'd)
- c) Connect 190, 10 MC output through 2 nsec cable, 874-VR and 50 Ω Terminator to the Input. Adjust 190 AMPLITUDE for 3 cm deflection. Adjust Monitor DC Level to center graticule Line with Test Plug-in sensitivity at 10 MV/cm DC.

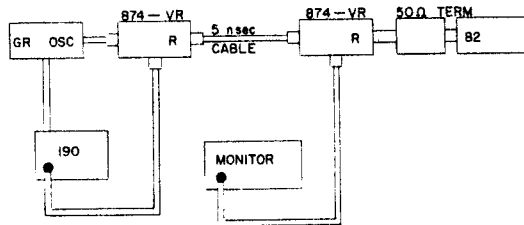

- d) Disconnect 2 nsec cable from 190 and connect to GR Oscillator. Adjust GR OSC frequency to 85 MC. Adjust GR output amplitude for same DC level on Monitor scope. Deflection should read 2.0 cm or more.

Monitored DC will have a small 60 cycle component present. This is due to 190 P.S. ripple modulating the signal frequency.

13. X10 BANDPASS MEASUREMENT:

- A. Setup
- a) Same as Step 14 except GAIN to X10 and 10:1T pad inserted between 50 Ω Terminator and 874-VR.
- b) Check bandpass in same manner as Step 12 c and d, except with GR OSC set at 80 MC.

Since published specs list bandpass at 3 db as approximate for the Type 86, small variations may be tolerated. Factory QC has chosen 3.5 db at 85 MC and 3.5 db at 80 MC as the lower limits for the X1 and X10 amplifiers.

IV CERTIFICATION PROCEDURE:

The following portion of the Type 86 may be certified:

<u>Function</u>	<u>Calibration Step No.</u>	<u>Standard Test Equip.</u>
GAIN	3 and 5	Type 580 AMPLITUDE CALIBRATOR

In order for the certification to be valid, the following conditions must exist:

- 1) The Amplitude Calibrator of the Type 580 used to check the gain of the Type 86 must be calibrated with a Standard Square Wave Calibrator that is traceable to the National Bureau of Standards.
- 2) A certificate must be on file verifying that the Standard Square Wave Calibrator is certified. This certificate is supplied by Field Maintenance Support with the Standard Square Wave Calibrator.
- 3) Record of the customer's instrument certification must be recorded and placed on file. The record should include the description and s/n of the standard test equipment used to certify the Amplitude Calibrator and the Type 86.
- 4) A certificate (TEK) should be filled out and returned to the customer with the instruments.

V RECALIBRATION CHECK SHEET:

1. X1 Position Range Coarse Adjustment R141 _____.
2. Distributed Amplifier Bias and Tube Bal. _____.
Output DC Voltage 50 V,
±3 V _____.
3. X1 Gain Adj. R549 _____.
4. X1 Position Range Final Adjustment R141 _____.
5. X10 Amplifier Gain R356 _____.
6. Gas and Microphonics check _____.
Grid Current Zero, R121 _____.
Noise check _____.
7. X10 Position Range, R336 _____.
8. Input capacitor C127 _____.
9. Volts/CM Switch Compensation:
Volts/CM Sw.

0.2	C103C _____.	C103B _____.
0.5	C105C _____.	C105B _____.
1.0	C107C _____.	C107B _____.
2.0	C109C _____.	C109B _____.
5.0	C111C _____.	C111B _____.
10.0	C113C _____.	C113B _____.
20.0	C115C _____.	C115B _____.
10. X1 High Frequency Compensation:
C167 _____.
C168 _____.
C524 _____.
11. X10 High Frequency Compensation:
C316 _____.
C318 _____.
C328 _____.
C356 _____.
C387 _____.
12. X1 Bandpass check, 85 MC _____.
13. X10 Bandpass check, 80 MC _____.