

Instructions

Tektronix

K415
Transport Cart
070-8843-01

WARRANTY

Tektronix warrants that the products that it manufactures and sells will be free from defects in materials and workmanship for a period of one (1) year from the date of shipment. If a product proves defective during this warranty period, Tektronix, at its option, either will repair the defective product without charge for parts and labor, or will provide a replacement in exchange for the defective product.

In order to obtain service under this warranty, Customer must notify Tektronix of the defect before the expiration of the warranty period and make suitable arrangements for the performance of service. Customer shall be responsible for packaging and shipping the defective product to the service center designated by Tektronix, with shipping charges prepaid. Tektronix shall pay for the return of the product to Customer if the shipment is to a location within the country in which the Tektronix service center is located. Customer shall be responsible for paying all shipping charges, duties, taxes, and any other charges for products returned to any other locations.

This warranty shall not apply to any defect, failure or damage caused by improper use or improper or inadequate maintenance and care. Tektronix shall not be obligated to furnish service under this warranty a) to repair damage resulting from attempts by personnel other than Tektronix representatives to install, repair or service the product; b) to repair damage resulting from improper use or connection to incompatible equipment; c) to repair any damage or malfunction caused by the use of non-Tektronix supplies; or d) to service a product that has been modified or integrated with other products when the effect of such modification or integration increases the time or difficulty of servicing the product.

THIS WARRANTY IS GIVEN BY TEKTRONIX IN LIEU OF ANY OTHER WARRANTIES, EXPRESS OR IMPLIED. TEKTRONIX AND ITS VENDORS DISCLAIM ANY IMPLIED WARRANTIES OF MERCHANTABILITY OR FITNESS FOR A PARTICULAR PURPOSE. TEKTRONIX' RESPONSIBILITY TO REPAIR OR REPLACE DEFECTIVE PRODUCTS IS THE SOLE AND EXCLUSIVE REMEDY PROVIDED TO THE CUSTOMER FOR BREACH OF THIS WARRANTY. TEKTRONIX AND ITS VENDORS WILL NOT BE LIABLE FOR ANY INDIRECT, SPECIAL, INCIDENTAL, OR CONSEQUENTIAL DAMAGES IRRESPECTIVE OF WHETHER TEKTRONIX OR THE VENDOR HAS ADVANCE NOTICE OF THE POSSIBILITY OF SUCH DAMAGES.

Copyright © Tektronix, Inc. 1993. All rights reserved.

Tektronix products are covered by U.S. and foreign patents, issued and pending. Information in this publication supercedes that in all previously published material. Specifications and price change privileges reserved.

Printed in the U.S.A.

Tektronix, Inc., P.O. Box 1000, Wilsonville, OR 97070-1000

TEKTRONIX and TEK are registered trademarks of Tektronix, Inc.



Contents

Safety Summary	ii
Introduction	1
Base Assembly	5
Drawer Shelf and Drawer	9
Straight Shelf	13
Top Shelf with Handle	15
Leg Caps	16
Nylon Straps	17
Customization	18
Replaceable Parts	19
Specifications	20

Safety Summary

Observe these safety precautions when using the K415 Transport Cart.

Keep the K415 Level

Keep the K415 level at all times, especially when it is loaded with instruments. The cart is designed to be very stable, but it can fall over if tilted to extremes. Observe this precaution especially in these cases:

- When rolling the cart across uneven floors.
- When rolling the cart through doorways with uneven thresholds.
- When lifting the cart wheels over cables.
- When rolling the cart up or down ramps.

Do Not Overload Shelves

Do not put more weight on any cart shelf than is listed in the specifications. Load the top of the cart evenly.

Observe Electrical Safety

All parts of the cart must be treated as electrical conductors, even if they appear to be nonconducting. Do not rely on the casters to provide insulation between the cart and the surface it stands on. Conversely, do not rely on the casters to provide a conductive ground path for the cart.

Test the Stability of Custom Configurations

Changes in shelf location and loading can affect the balance of the cart. If you arrange the shelves differently from the configuration described in this manual, test the cart carefully for stability before using it.

Introduction

The Tektronix K415 Transport Cart requires some assembly. This manual tells how to assemble and use the cart.

You can assemble the K415 Transport Cart by yourself, but it is easier if you have another person to help you.

You will need a large flat area to assemble the cart. The area should be level and large enough to move the various parts into place. A carpeted floor space is ideal.

Tools

You will need a 3/4 inch (19 mm) open-end wrench, or an adjustable wrench that can be adjusted to that size.

Other tools are included with the K415 Transport Cart. These include a 3/16 inch Allen wrench and a circular bubble level.

Parts Identification

The large pieces of the K415 Transport Cart are packed separately in the shipping carton. A bag of small parts is packed in a box with these instructions. The included tools are also packed in this bag. Figure 1 on page 2 shows the small parts you will be using.

Table 1 on page 3 lists all the parts needed to assemble the cart, including the large pieces and assemblies. Take an inventory now to familiarize yourself with the parts for the assembly process.

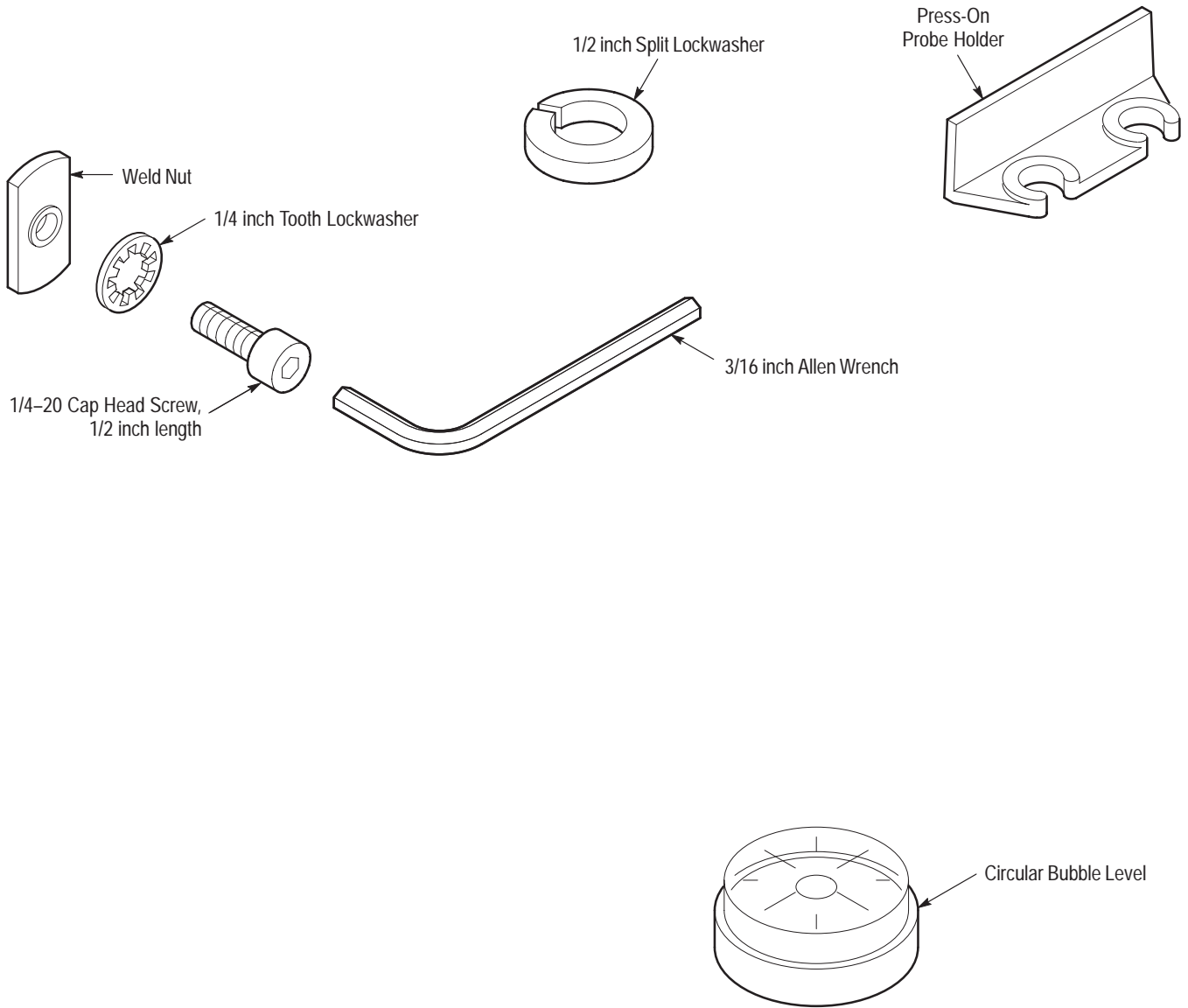

Figure 1: Identification of Small Parts

Table 1: Parts List

Quantity	Description
Large Parts	
2	Locking Casters
2	Non-Locking Casters
1	Top Shelf with handle
1	Straight Shelf
1	Drawer Shelf
1	Drawer
1	Strut
2	Leg Assemblies
2	Leg Caps
2	Nylon Straps with buckles
Small Parts in Bag	
4	1/2 inch Split Lockwashers
16	1/4-20 cap-head screws, 1/2 inch length
16	1/4 inch Tooth Lockwashers
16	Weld Nuts
1	Press-On Probe Holder
Small Tools in Bag	
1	3/16 inch Allen Wrench
1	Circular Bubble Level

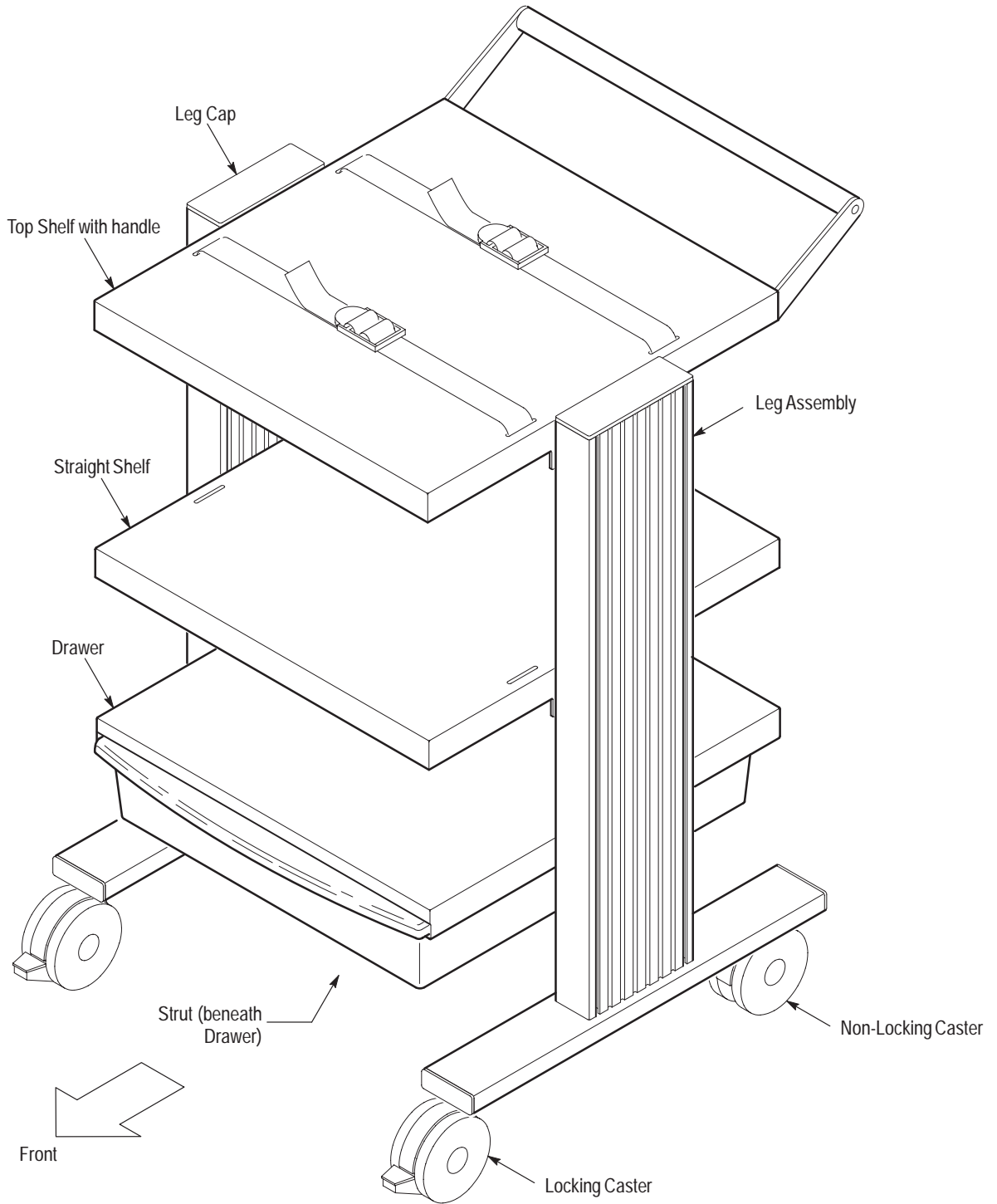

Figure 2: The K415 Transport Cart

Base Assembly

Begin assembling the cart by joining the leg assemblies using the strut, and then putting on the casters. You will use these parts:

- 2 Locking Casters
- 2 Non-Locking Casters
- 2 Leg Assemblies
- 1 Strut
- 4 1/2 inch Split Lockwashers
- 4 1/4–20 Cap Head Screws, 1/2 inch length
- 4 1/4 inch Tooth Lockwashers
- 4 Weld Nuts

You will use a 3/4 inch (19 mm) wrench or adjustable wrench, and the 3/16 inch Allen wrench included with your cart.

1. Prepare the strut as shown in Figure 3. Position the weld nut with the raised threaded flange toward the strut. *Leave each screw assembly loose; do not screw the weld nut onto the cap head screw more than one full turn.*

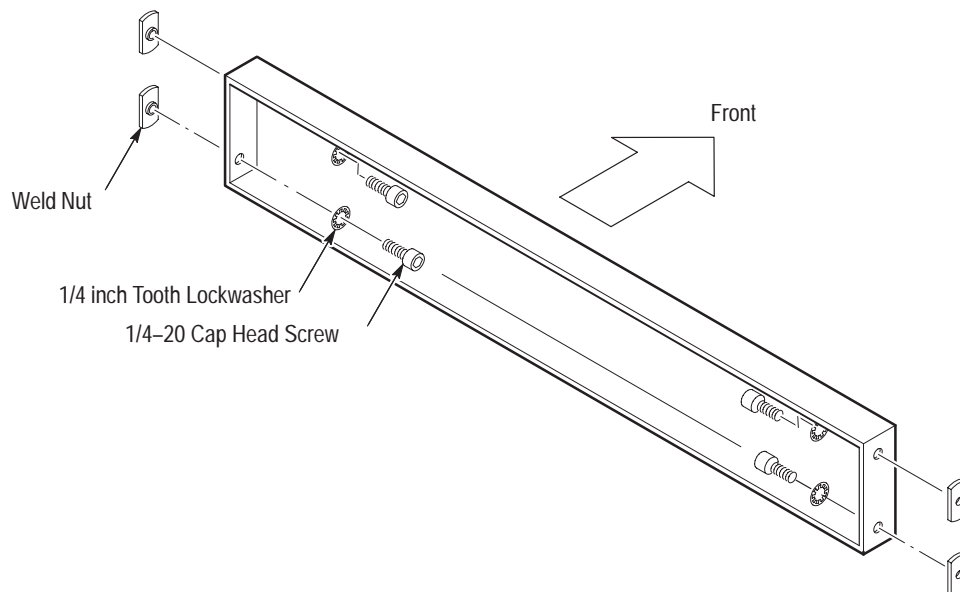

Figure 3: Preparing the Strut for Base Assembly

2. On each leg assembly, observe that there is a small, clear, plastic button on the horizontal leg bar. This button is on the *inside* of the cart, *at the back*. Position the leg assemblies as shown in Figure 4. Leave a space between the leg assemblies about equal to the length of the strut.

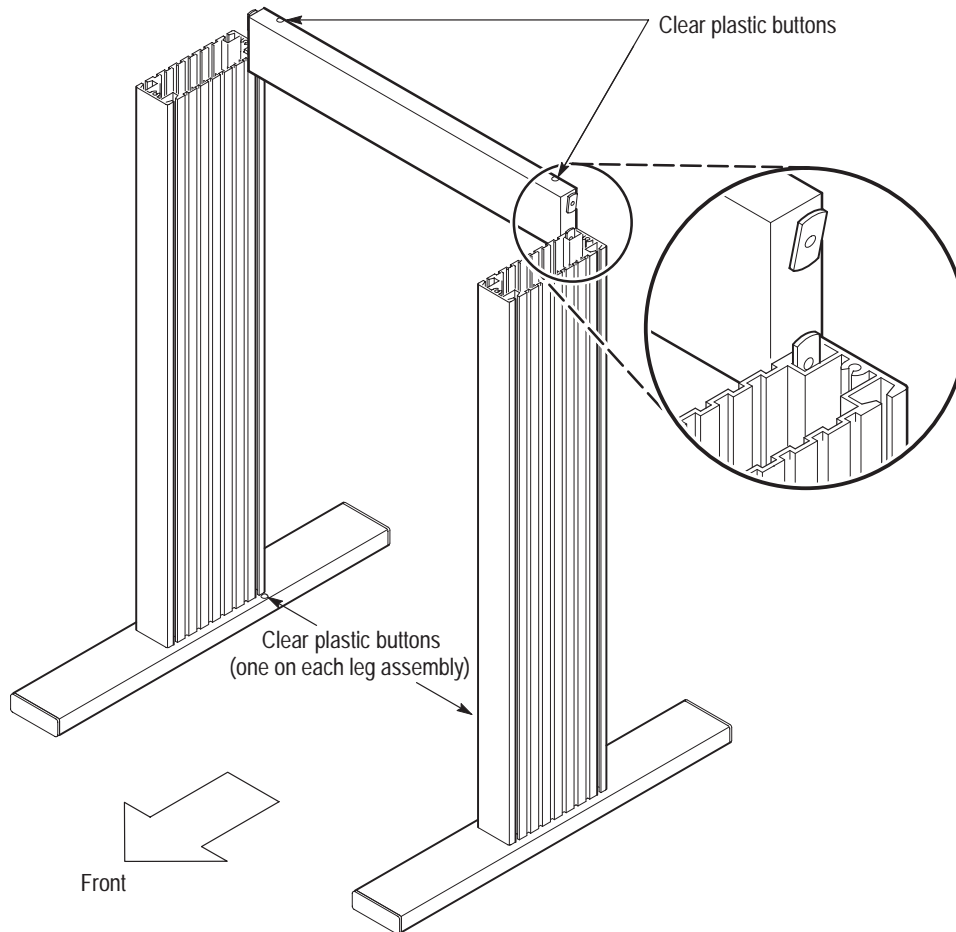

Figure 4: Aligning the Leg Assemblies and the Strut

3. Position the strut horizontally between the leg assemblies, as shown in Figure 4, with the open side of the strut to the back. Line up the weld nuts with the *back* groove in the leg assemblies.

The strut has two clear plastic buttons, similar to the ones on the leg assemblies. Position the strut so these buttons are on top; the wire basket will rest on these buttons.

4. Slide the strut down to the base of the cart, adjusting the distance between the leg assemblies as needed. When complete, make sure the strut is resting tight against the clear plastic buttons on the leg assemblies.

5. Use the 3/16 inch Allen wrench to tighten the cap head screws. Tighten them first snugly, then go back and tighten them firmly.

NOTE. If you have a torque wrench available, tighten these and all shelf screws to 60 in·lb (6.8 N·m) torque.

6. Tip the cart onto its back as shown in Figure 5, resting it on the work surface by the tops and backs of the leg assemblies.
7. Identify which casters are locking and which are non-locking. The locking casters, which go on the front of the cart, have an extra tab that you step on to lock the wheels.

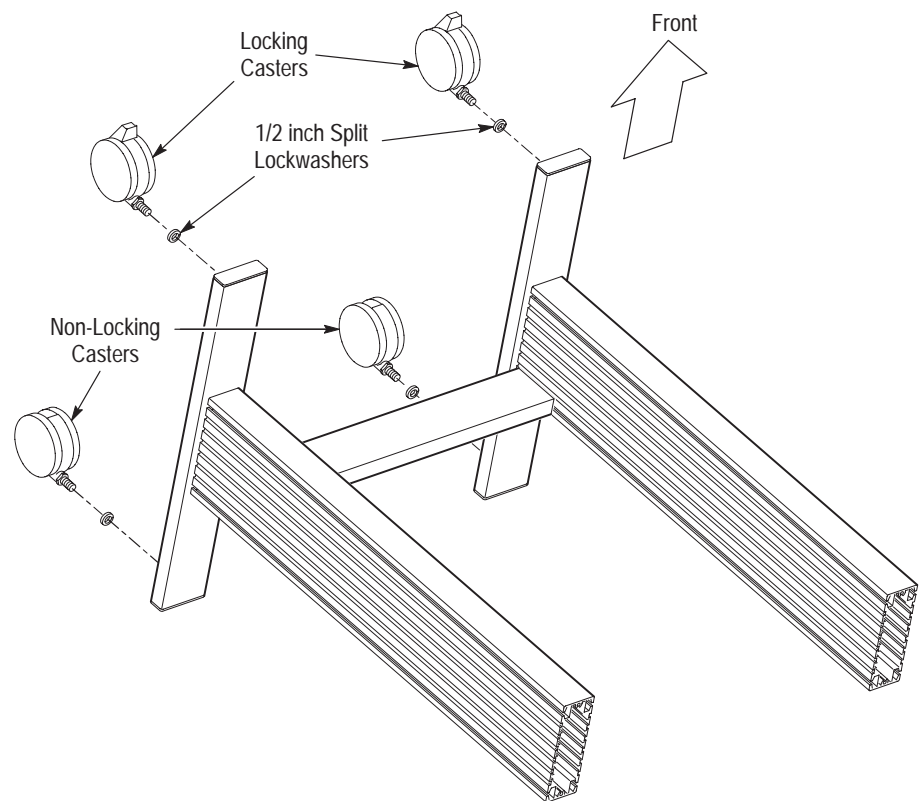

Figure 5: Installing the Casters

8. On the *locking* casters, place a 1/2 inch split lockwasher on each threaded shaft, then install the casters into the two *front* holes in the bottoms of the leg assemblies. Tighten the casters only until they are snug using the 3/4 inch (19 mm) wrench.

9. On the *non-locking* casters, place a 1/2 inch split lockwasher on each threaded shaft, then install the casters into the two *back* holes in the bottoms of the leg assemblies. Tighten the casters only until they are snug.
10. Return the cart to the upright position.

Drawer Shelf and Drawer

Install a drawer shelf and drawer in the cart. You will use these parts:

- 1 Drawer Shelf
- 1 Drawer
- 4 1/4–20 Cap Head Screws, 1/2 inch length
- 4 1/4 inch Tooth Lockwashers
- 4 Weld Nuts
- 2 Press-Stud Retainers

You will use the 3/16 inch Allen wrench and the circular bubble level included with your cart.

1. Prepare the drawer shelf as shown in Figure 6 by installing a cap head screw, a tooth lockwasher, and a weld nut in each of the four side holes of the shelf. Leave each screw assembly loose; do not screw the weld nut onto the cap head screw more than one full turn.

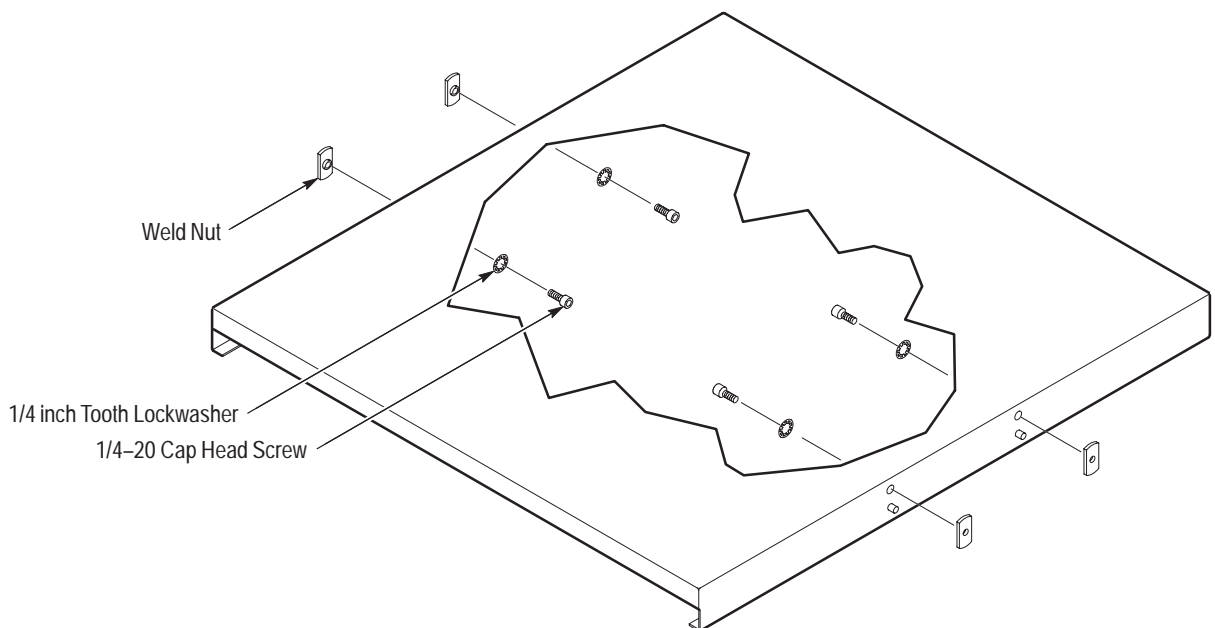

Figure 6: Preparing the Drawer Shelf

2. Position the drawer shelf horizontally between the leg assemblies, as shown in Figure 7. Position the shelf so the open edge is to the front of the cart.

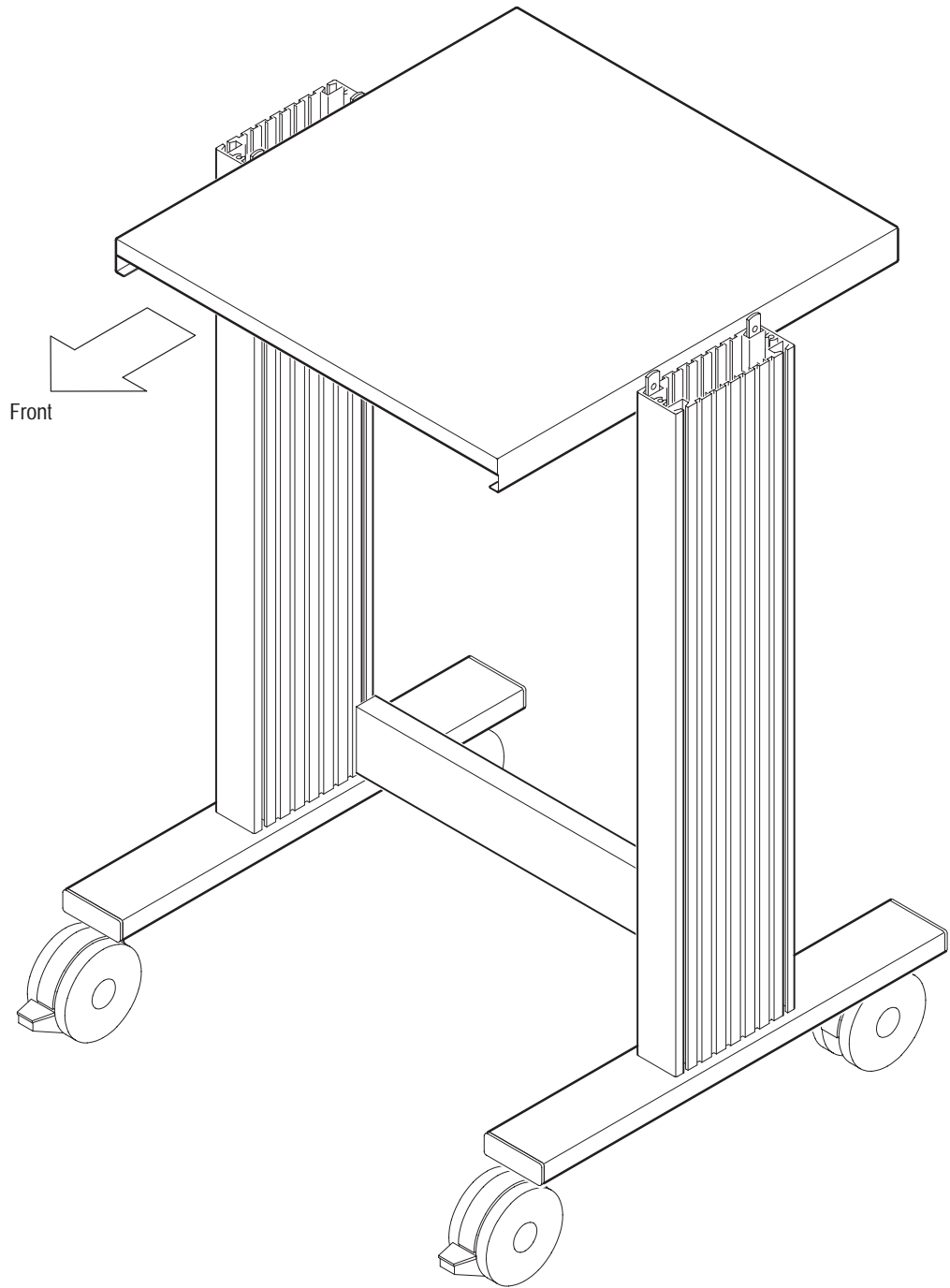

Figure 7: Aligning the Drawer Shelf

3. Slide the drawer shelf down to into the position shown in Figure 8. (A light pencil line has been marked on the insides of the leg assemblies at this position.) Slide the drawer shelf *slowly* between the leg assemblies to avoid scratching the paint. Use the circular bubble level to make sure the shelf is level.

If you have another person helping you, that person can hold the shelf at the proper height as you tighten the screws. If you are assembling the cart by yourself, tighten each screw in turn just enough to hold, and then adjust the heights one by one until the shelf is positioned properly.

4. Use the 3/16 inch Allen wrench to tighten the cap head screws. Tighten them first snugly, then go back and tighten them firmly.

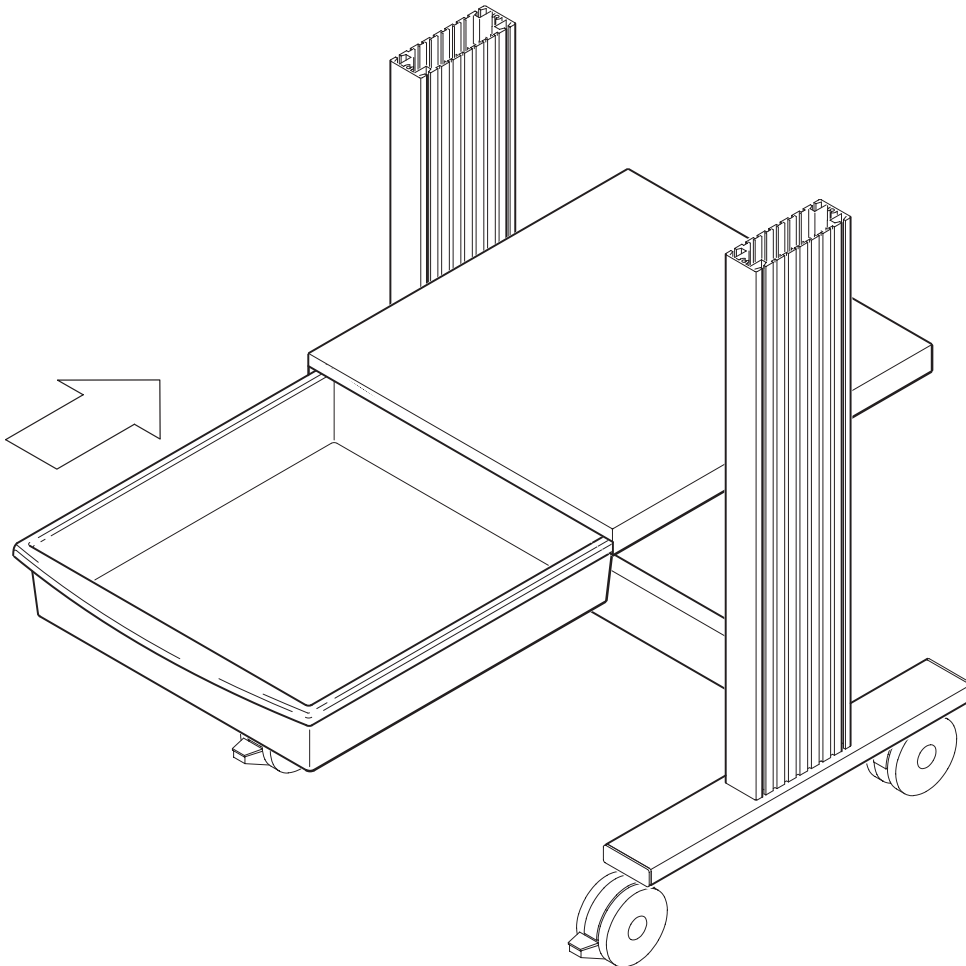

Figure 8: Installing the Drawer

5. Slide the drawer in underneath the drawer shelf as shown in Figure 8. Position the drawer so that the curved edge is to the front of the cart. Slide the drawer into the shelf until it stops.
6. Use your thumb to press into place the two press-stud retainers at the bottom of the drawer rails, as shown in Figure 9.

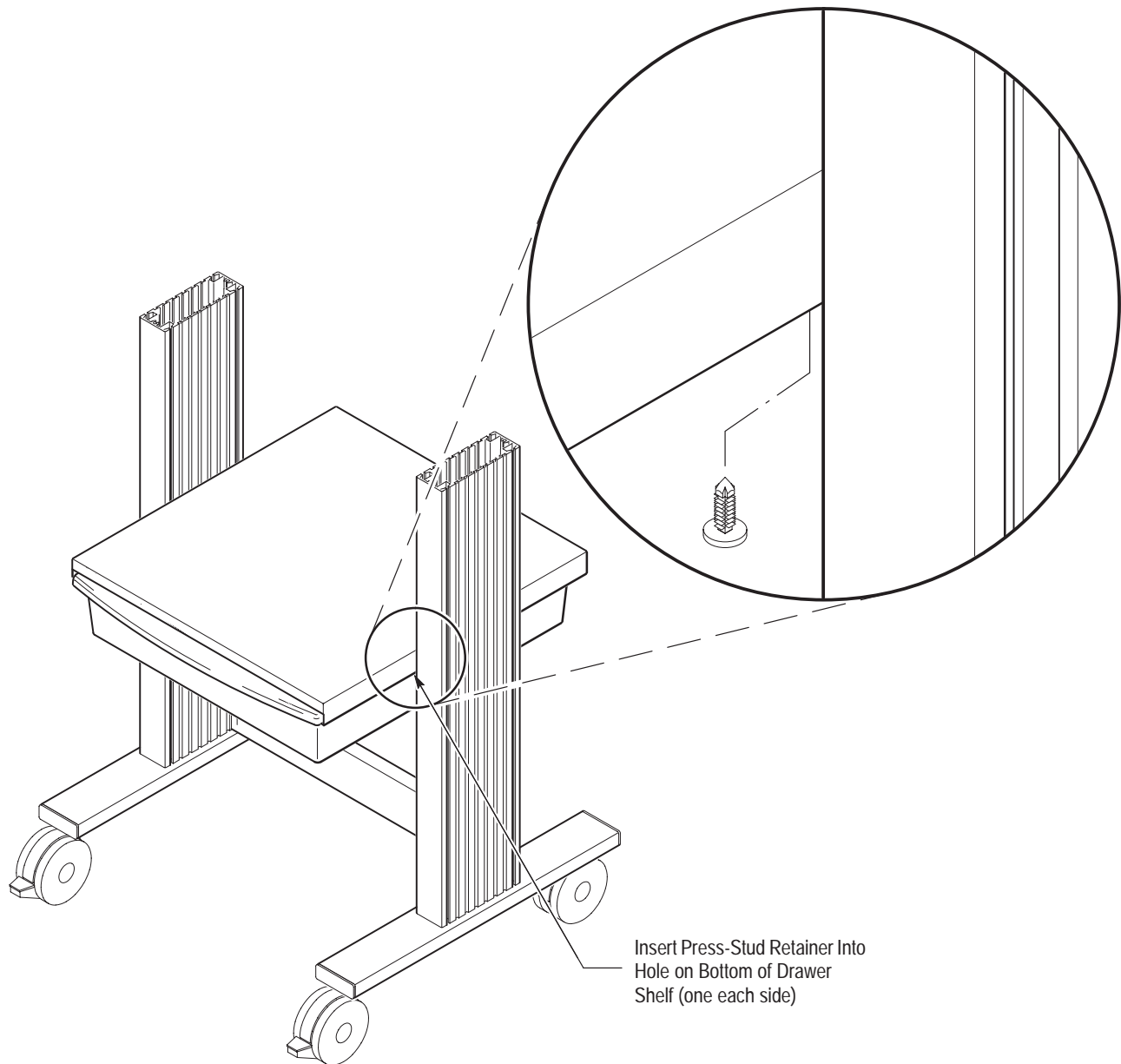

Figure 9: Installing the Press-Stud Retainers

Straight Shelf

Install a straight shelf in the cart. You will use these parts:

- 1 Straight Shelf
- 4 1/4–20 Cap Head Screws, 1/2 inch length
- 4 1/4 inch Tooth Lockwashers
- 4 Weld Nuts

You will use the 3/16 inch Allen wrench and the circular bubble level included with your cart.

1. Prepare the straight shelf as shown in Figure 10 by installing a cap head screw, a tooth lockwasher, and a weld nut in each of the four side holes of the shelf. Leave each screw assembly loose; do not screw the weld nut onto the cap head screw more than one full turn.

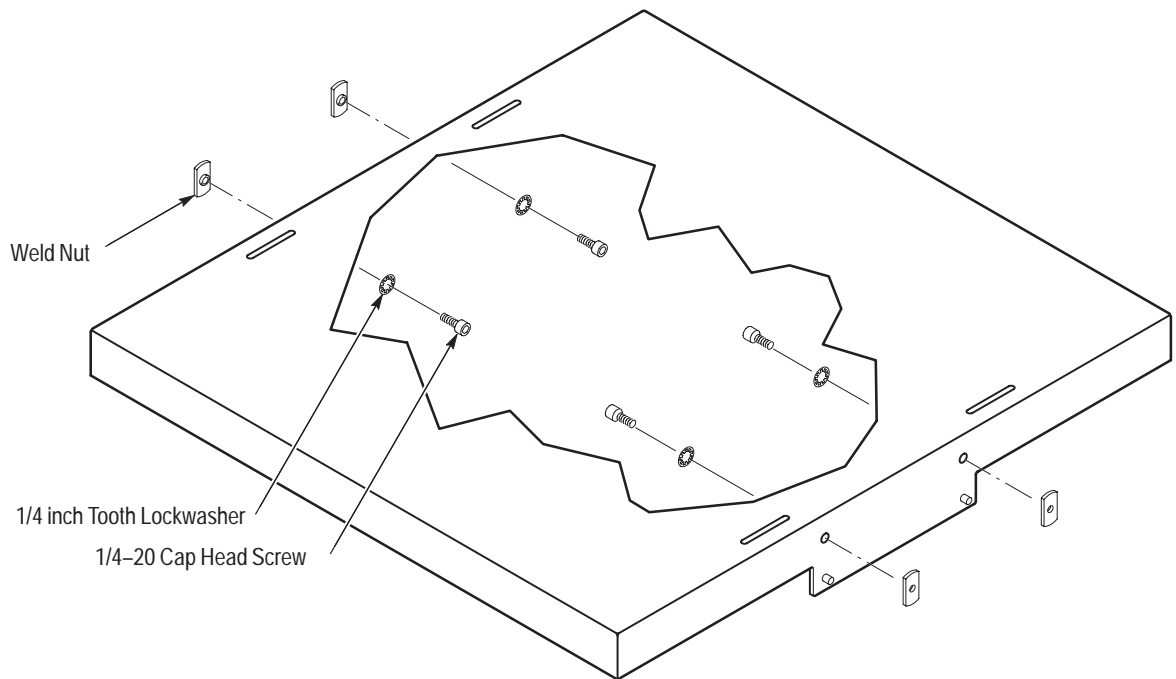

Figure 10: Preparing the Straight Shelf

2. Position the straight shelf horizontally between the leg assemblies, as shown in Figure 11. There is no designated front or back to the straight shelf; you can position it with either end to the front.

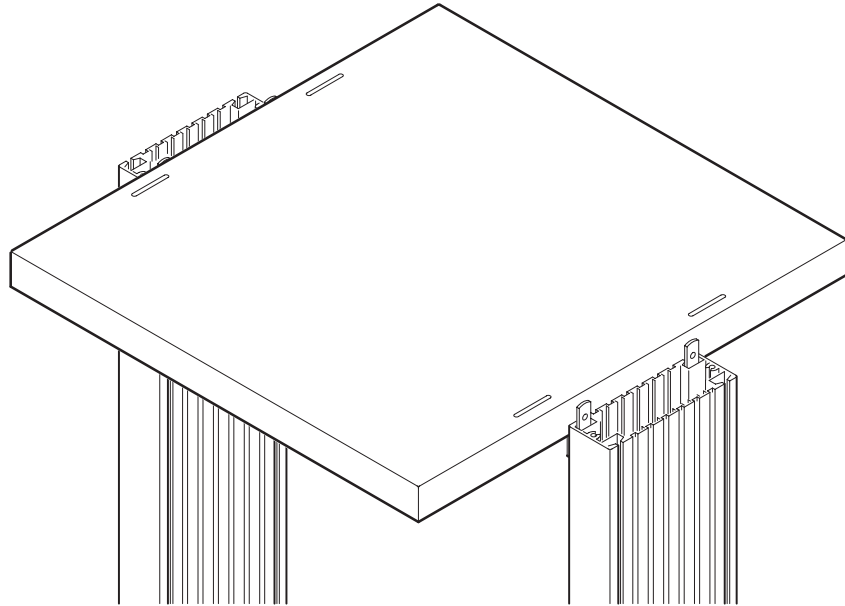

Figure 11: Aligning the Straight Shelf

3. Slide the straight shelf down into position. A light pencil line has been marked on the insides of the leg assemblies at this position. Slide the straight shelf *slowly* between the leg assemblies to avoid scratching the paint. Use the circular bubble level to make sure the shelf is level.

If you have another person helping you, that person can hold the shelf at the proper height as you tighten the screws. If you are assembling the cart by yourself, tighten each screw in turn just enough to hold, and then adjust the heights one by one until the shelf is positioned properly.

4. Use the 3/16 inch Allen wrench to tighten the cap head screws. Tighten them first snugly, then go back and tighten them firmly.

Top Shelf with Handle

Install the top shelf in the cart in the same way that you installed the straight shelf. This shelf should be at the same height as the tops of the leg assemblies.

Position the top shelf with the handle to the *rear* of the cart. The rear has the non-locking casters. You will use these parts:

- 1 Top Shelf with Handle
- 4 1/4–20 Cap Head Screws, 1/2 inch length
- 4 1/4 inch Tooth Lockwashers
- 4 Weld Nuts

You will use the 3/16 inch Allen wrench and the circular bubble level included with your cart.

Leg Caps

Install the two leg caps in the tops of the leg assemblies. You do not need any tools to install the leg caps.

Press a leg cap into the top of each leg assembly as shown in Figure 12. You may need to press them into place with the heel of your hand.

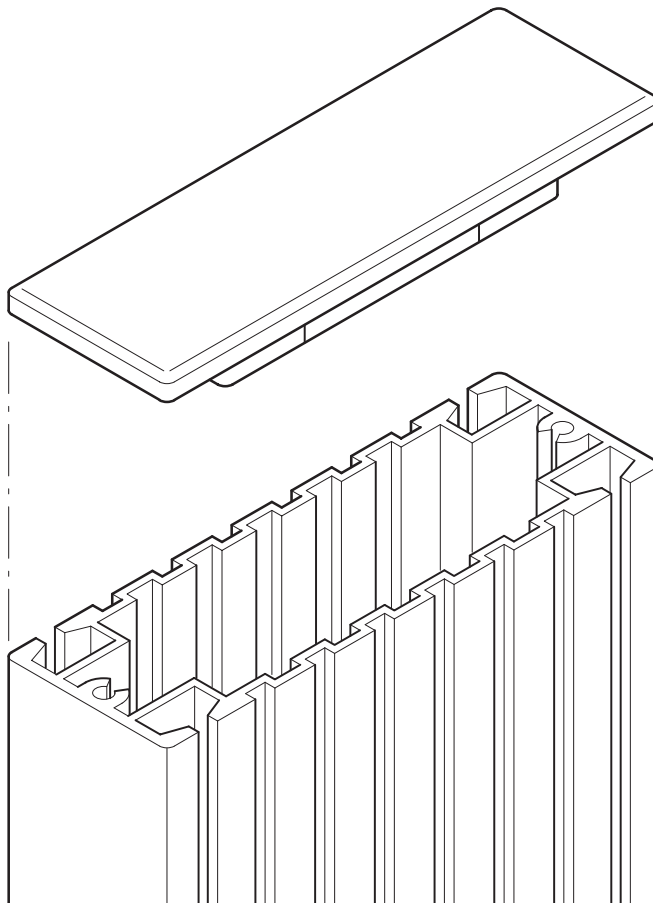

Figure 12: Installing the Leg Caps

Nylon Straps

The last assembly step to finish your cart is to install the two Nylon straps with buckles. You do not need any tools for this step.

Many of the shelves of your cart have slots for installing Nylon straps. Straight shelves have slots for two straps each, and half shelves have slots for one strap each. You should install your straps in the shelves you will be using to hold instruments.

Install the Nylon straps as shown in Figure 13. Note the routing of the strap through the buckle. This routing allows you to tighten the strap around an instrument by pulling on the free end of the strap. To loosen a strap, pull up on the tab of the buckle.

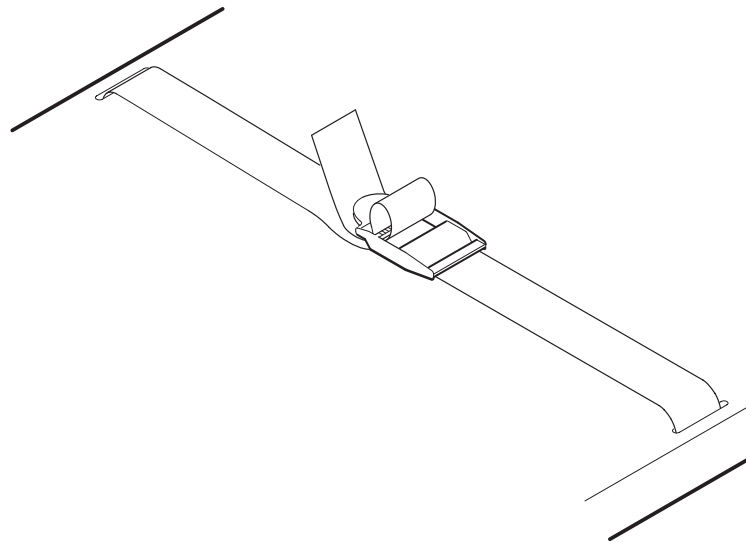

Figure 13: Installing the Nylon Straps with Buckles

Customization

You can customize your cart in several ways:

- You can adjust the heights of any of the shelves. First remove all equipment from the cart. Loosen the four screws associated with the shelf (or for tilting shelves, the shoulder bolts, oval knobs, and set screws), adjust the height, level, and retighten.
- You can move the Nylon straps to any shelf where they are needed.
- You can apply the press-on probe holder anywhere on the cart that is convenient. Once applied, it cannot be moved. Make sure the place you are applying it is clean and dry. Peel the backing from the sticky tape and press holder into place.
- You can rearrange the configuration of the shelves by disassembling the cart and reassembling it in a different order. Remember to build the cart from the bottom, shelf by shelf.



WARNING. *Changes in shelf location and loading can affect the balance of the cart. If you arrange the shelves differently from the configuration described in this manual, test the cart carefully for stability before using it.*

Replaceable Parts

Contact your Tektronix representative to order replacement parts. Within the United States and Canada, you can call **1-800-TEK-WIDE (1-800-835-9433)**.

You can order the following parts to repair the K415 Transport Cart:

- Locking Caster, Tektronix part number 401-0691-00.
- Non-Locking Caster, Tektronix part number 401-0690-00.
- Nylon Strap with Buckle, Tektronix part number 346-0261-00.
- Replacement bar handle with foam cover and set screws, Tektronix part number 367-0452-00.
- Package of assorted small hardware and leg caps, Tektronix part number 016-1259-00. Table 2 lists the parts included in this package.

Table 2: Parts Included with Tektronix Part Number 016-1259-00

Quantity	Part Description
2	Leg Caps
2	1/2 inch Split Lockwashers
4	Weld Nuts
2	Long Rails
8	1/4 inch Tooth Lockwashers
8	1/4–20 Cap Head Screws, 1/2 inch length
6	1/8 inch thick Kevlar (plastic) Washers
2	Oval Knobs
2	1/4 inch–20 Set Screws
2	3/4 inch Steel Washers
2	1/4–20 Shoulder Bolts, 1/2 inch length
2	Press-Stud Retainers

Specifications

The K415 Transport Cart meets the specifications in Table 3. Table 4 shows additional characteristics.

Table 3: Performance Specifications

Parameter	Specification
Loading Limit, Shelves	34 kg (75 lb)
Loading Limit, Drawer	6.8 kg (15 lb)

Table 4: Physical Characteristics

Parameter	Typical Characteristic
Overall Dimensions height width depth	908 mm (36.0 in) 635 mm (25.0 in) 533 mm (21.0 in)
Top Shelf Dimensions width depth	508 mm (20.0 in) 533 mm (21.0 in)
Straight Shelf Dimensions width depth	508 mm (20.0 in) 533 mm (21.0 in)
Drawer Shelf Dimensions width depth	508 mm (20.0 in) 533 mm (21.0 in)
Drawer Dimensions width depth	496 mm (19.5 in) 559 mm (22.0 in)

