

9869441

P6106 VOLTAGE PROBE

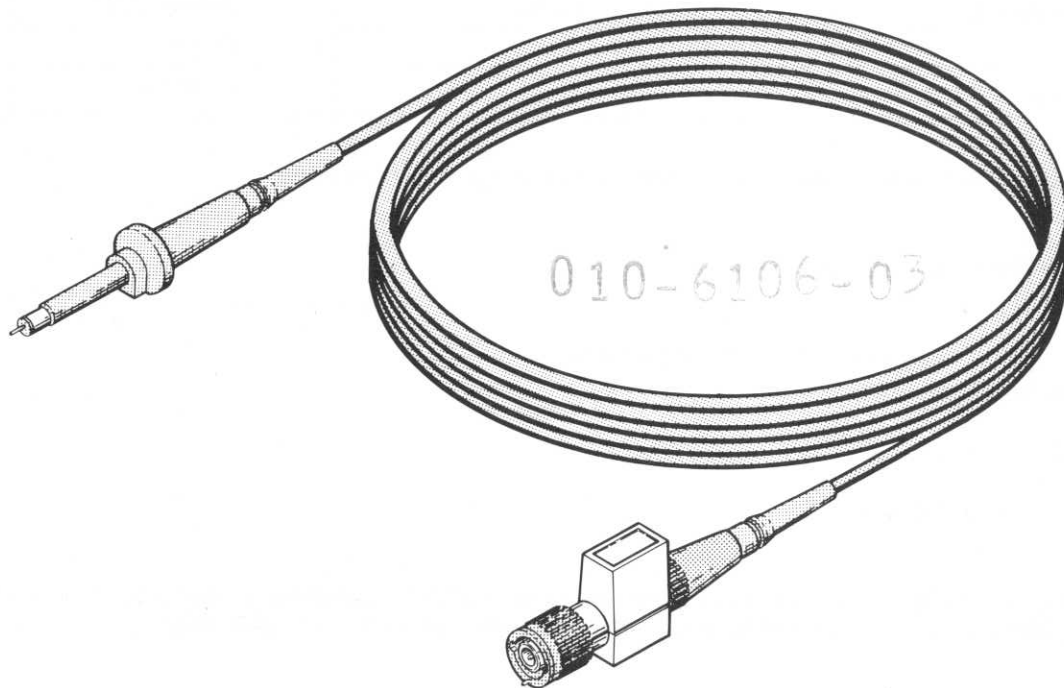

The P6106 Probe is a miniature, 10X passive probe for use with dc to 350 MHz oscilloscopes with an input capacitance range of 15-24 pF and an input resistance of 1 M Ω .

A ground reference push button on the probe head permits the user to obtain a ground reference or to identify a trace in a multitrace display. A coding pin on the BNC output connector actuates the Volts/Div readout encoding of certain oscilloscopes to include the 10X attenuation of the probe.

WARNING

To avoid shock, do not disassemble when connected to voltage source. Disassembly is a service operation only. Refer servicing to qualified service personnel.

The compensating box houses an adjustable network that provides optimum transient response when used with oscilloscopes having bandwidths up to 350 MHz. The probe can be low-frequency compensated by adjusting the variable capacitor through the hole in the compensating box housing.

Modular construction of the probe simplifies repairs, as both probe head and compensating box can be unplugged from the cable assembly.

The P6106 Probe is available in three lengths and is identified by the colored strain relief at each end of the cable: blue – 1 meter (3.3 ft), yellow – 2 meter (6.6 ft), red – 3 meter (9.9 ft).

NO. 062-2765-00

DATE JAN. 1977

COPYRIGHT © 1977
TEKTRONIX INC.
ALL RIGHTS RESERVED

P6106 PROBE

SPECIFICATIONS

Electrical

Attenuation: 10X within 3% (oscilloscope input, 1 M Ω within 2%).

Input Resistance: 10 M Ω within 0.5% (oscilloscope input, 1 M Ω within 2%).

Approximate Input Capacitance:

1 Meter (3.3 ft.)	2 Meter (6.6 ft.)	3 Meter (9.9 ft.)
Blue	Yellow	Red
10.5 pF	13.0 pF	15.5 pF

See Fig. 1 and 2. Typical parallel reactance (X_p) and resistance (R_p) versus frequency.

Compensation Range: 15 pF to 24 pF.

Bandwidth (-3 dB): (Oscilloscope bandwidth \geq 255 MHz).

1 Meter: at least 250 MHz.

2 Meter: at least 250 MHz.

3 Meter: at least 150 MHz.

All three probes are usable on oscilloscopes with bandwidths up to 350 MHz. When the 1-meter probe is used with oscilloscopes having bandwidths of at least 325 MHz the system bandwidth will typically be 300 MHz.

Maximum Input Voltage: 500 Volts (dc + peak ac) to 1.7 MHz derated to 70 V at 100 MHz. See Fig. 3, voltage derating with frequency curve.

Environmental

Probe operates within specifications over the following ranges:

Temperature: -15°C ($+5^{\circ}\text{F}$) to $+75^{\circ}\text{C}$ ($+167^{\circ}\text{F}$).

Altitude: To 15,000 feet.

Physical

Net weight (including accessories):

1 Meter (3.3 ft.) Probe: 111 grams (3.9 oz.)

2 Meter (6.6 ft.) Probe: 136 grams (4.8 oz.)

3 Meter (9.9 ft.) Probe: 159 grams (5.6 oz.)

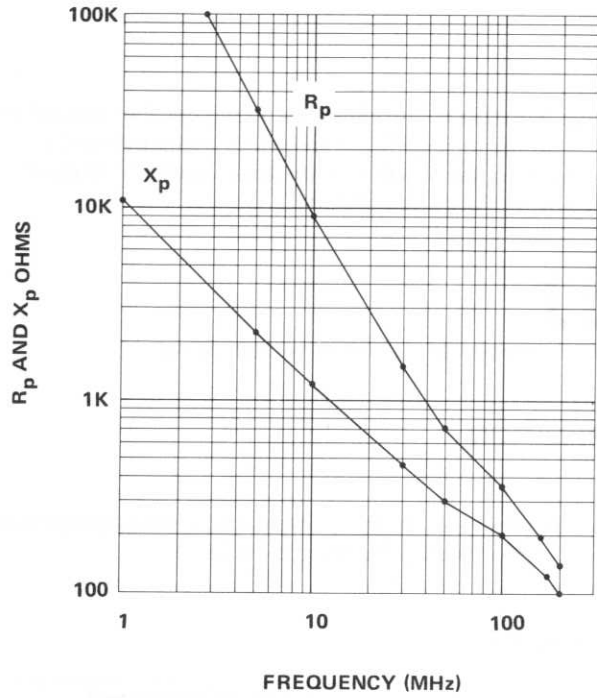

Fig. 1. P6106 Probe (1 meter cable), typical X_p , R_p versus frequency curves.

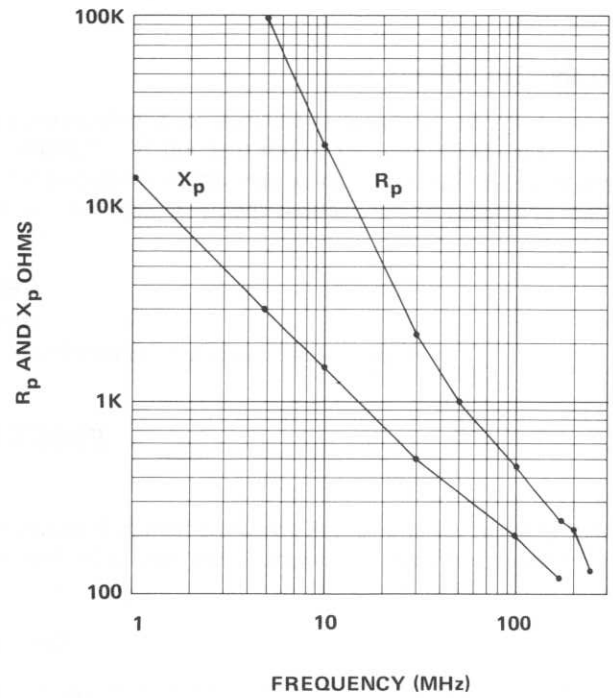

Fig. 2. P6106 Probe (2 and 3 meter cable), typical X_p , R_p versus frequency curves.

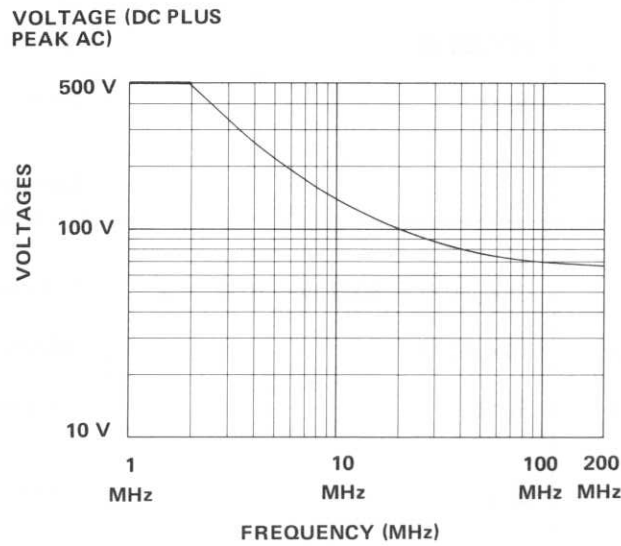

Fig. 3. P6106 Probe, typical voltage derating with frequency curve.

OPERATING CONSIDERATIONS

Probe Grounding

A passive probe is a capacitive divider for high-frequency components. Inductance introduced by a long signal or ground lead will form a series resonant circuit that will "ring" if driven by a signal containing significant frequency components at or above circuit resonance. These oscillations can appear on the oscilloscope display and distort the true waveform. Ground leads and probe tip connections should be kept as short as possible to maintain the best fidelity.



To avoid shock, do not disassemble the probe when connected to a signal or voltage source.

PROBE COMPENSATION

Due to slight variations in the oscilloscope input capacitance, it is usually necessary to compensate the probe whenever it is transferred from one instrument to another, or from one channel to another for dual (multitrace) units.

Test Equipment Required

Description	Minimum Specifications	Suggested Instrument
Oscilloscope System	Bandwidth 255 MHz, or greater	Tektronix 485 or 475A
Pulse or Square Wave Generator	Pulse rise time ≤ 1 ns, amplitude 0.5 V into 50 Ω	Tektronix PG 506 ¹ or Tektronix 106
Leveled Sine Wave Generator	0-3 volt p-p, 250 kHz to 250 KHz Sine Wave	Tektronix SG 503 ¹
Used With PG 506 and SG 503		
Cable With BNC Connectors	Coaxial, Precision 50 Ω , 36 inches	Tektronix PN 012-0482-00
Attenuator With BNC	10X, 50 Ω	Tektronix PN 011-0059-02
Thru-line Termination With BNC Connector	50 Ω	Tektronix PN 011-0049-01
Probe-tip-to-BNC Adapter		Tektronix PN 013-0084-01
Used With 106 Only		
Cable With GR Connectors	Coaxial, 5 ns, 50 Ω type RG213/U	Tektronix PN 017-0502-00
Attenuator With GR Connector	10X, 50 Ω	Tektronix PN 017-0078-00
Thru-line Termination with GR-to-BNC-Male Connectors	50 Ω	Tektronix PN 017-0083-00
Miniature Probe-tip-to-GR Termination Adapter	50 Ω	Tektronix PN 017-0088-00

¹ Requires TM 500-Series Power Module

Preliminary Procedure

1. Install P6106 Probe onto test oscilloscope input connector.
2. Turn test oscilloscope and associated test equipment power on and allow enough warmup time for equipment to stabilize.
3. Set test oscilloscope Volts/Div to 0.1 V (or 10 mV), Time/Div to 1 ms, and Calibrator for 5 V (or 0.4 V) 1 kHz signal.

Low-Frequency Compensation

1. Connect probe tip to test oscilloscope calibrator output.
2. Set test oscilloscope triggering controls for stable triggered display. Display should be approximately 10 cycles of square wave with an amplitude of 5 (or 4) divisions.
3. Adjust low-frequency compensation (C3, see Fig. 4) for optimum flat top on square wave.

High-Frequency Compensation

1. Disconnect P6106 Probe from test oscilloscope.
2. Connect positive rise (fast rise) output of pulse generator through a 50 Ω cable, a 10X attenuator, and a 50 Ω thru-line termination to test oscilloscope input connector.
3. Set generator period (repetition rate) switch to 100 kHz.
4. Set test oscilloscope Time/Div to 0.02 μ s and Volts/Div to 10 mV.
5. Adjust Amplitude control for 5 division pulse amplitude.
6. Note pulse shape and aberrations.
7. Remove 50 Ω cable, 10X attenuator from generator and test oscilloscope. Install P6106 Probe on test oscilloscope input connector.
8. Connect probe tip to positive rise (fast rise) output of generator using probe-tip-to-BNC adapter.
9. Check high-frequency aberrations by comparing probe/oscilloscope pulse response against display noted in step 6. Aberrations from reference response should not exceed +3%, -3%, or 5% P-P of pulse amplitude.
10. If aberrations are excessive, proceed as follows:
 1. Remove compensation box cover.
 - b. Adjust R2 and R4 for best overall flat response. See Fig. 5 for details of adjustment area on waveform relative to component adjustment. See Fig. 6 and 7 for adjustment positions relative to probe and length of cable.
 - c. Adjust R3 and C2 for best corner response (without ringing). See Fig. 5, 6, and 7.
11. Check P6106 Probe bandwidth with procedure as follows:
 - a. Remove probe tip from square wave generator output termination and connect, through probe tip-to-BNC adapter and thru-line termination, to the SG 503 Leveled Sine Wave Generator Output.

P6106 PROBE

- b. Set generator to 50 kHz reference frequency.
 - c. Adjust generator Output Amplitude until signal reaches 6 divisions on the oscilloscope graticule.
 - d. Set generator Frequency Range (MHz) to 100/250.
 - e. Sweep from 100 through to 250 MHz with Frequency Variable to see if waveform amplitude falls below 4.2 divisions (-3 dB).
 - f. If amplitude does fall below 4.2 divisions before reaching 250 MHz, go back to step 10 and proceed through aberrations adjustments and bandwidth check again.
 - g. If not, go to next step.
12. Remove cable and adapters used with the SG 503 and connect cable and adapters used with square wave generator as in steps 7 and 8.
 13. Replace compensation box cover.
 14. Recheck waveform with compensation box cover installed as in step 10b.

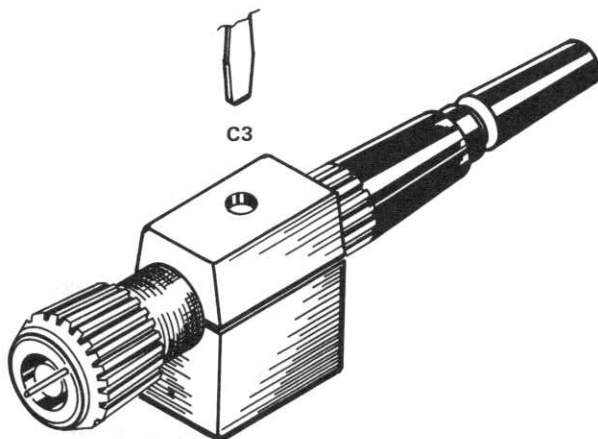

Fig. 4. Low-frequency adjustment.

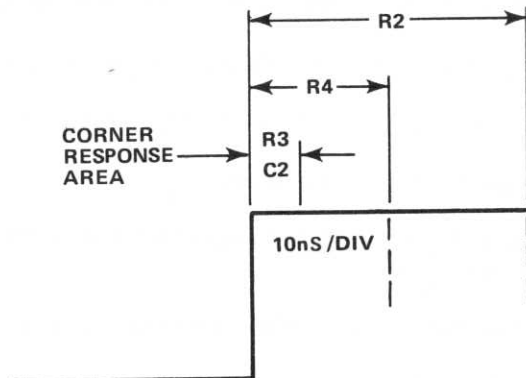

Fig. 5. Adjustments relative to waveform section.

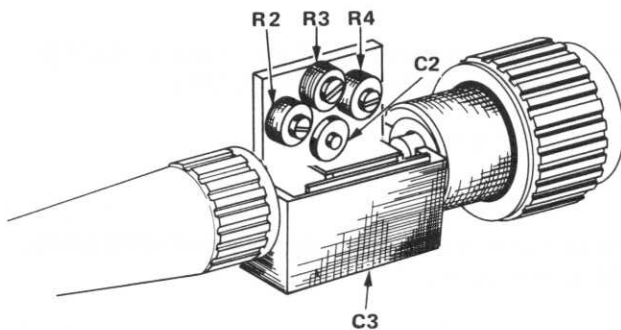

Fig. 6. High-frequency adjustments, 1 meter cable length.

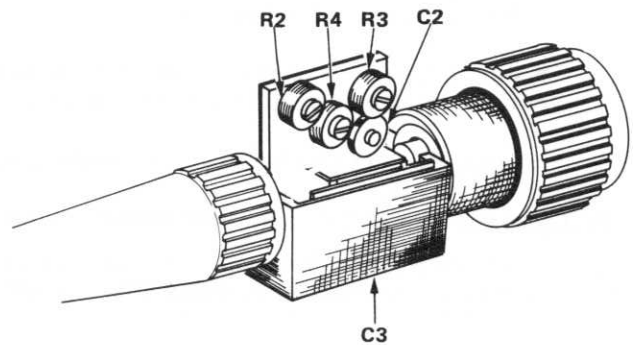

Fig. 7. High-frequency adjustments, 2 & 3 meter cable length.

MAINTENANCE

WARNING

To avoid shock, do not disassemble probe when connected to voltage source. Only qualified service personnel should use the following service instructions. Unless you are qualified to do so, perform no servicing except that contained in the preceding operating instructions.

The P6106 Probe is designed to withstand normal operation and handling. However, if the probe fails or breaks, replacement parts are available. See Replaceable Parts List for part numbers.

Replacing A Probe Assembly:

If the coaxial cable, probe head, or compensation box should fail, the assemblies are available. When replacing probe assemblies, make sure to use the proper probe head and/or compensation box for the length of cable being used. Check that colors on the probe-head ground collar and compensation box retainer nut match the cable strain reliefs.

Removing Probe Tip:

See Fig. 8 for probe tip removal and replacement.

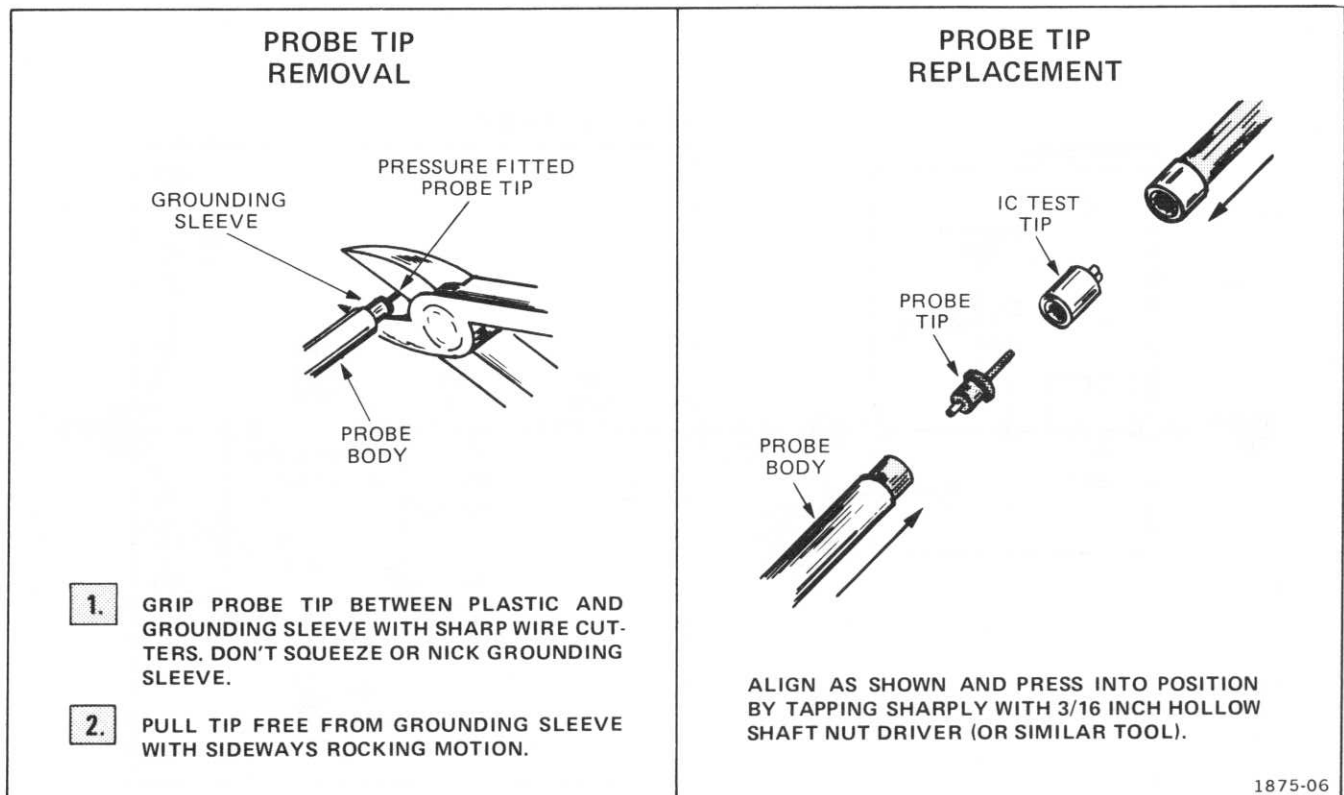
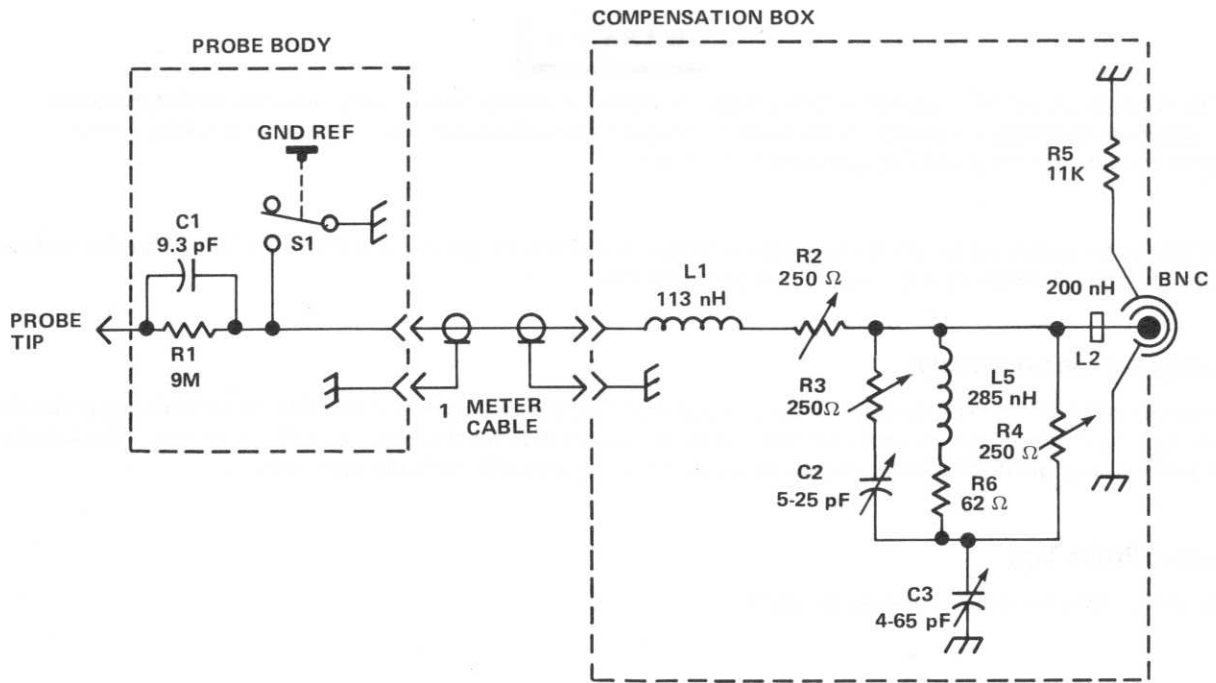
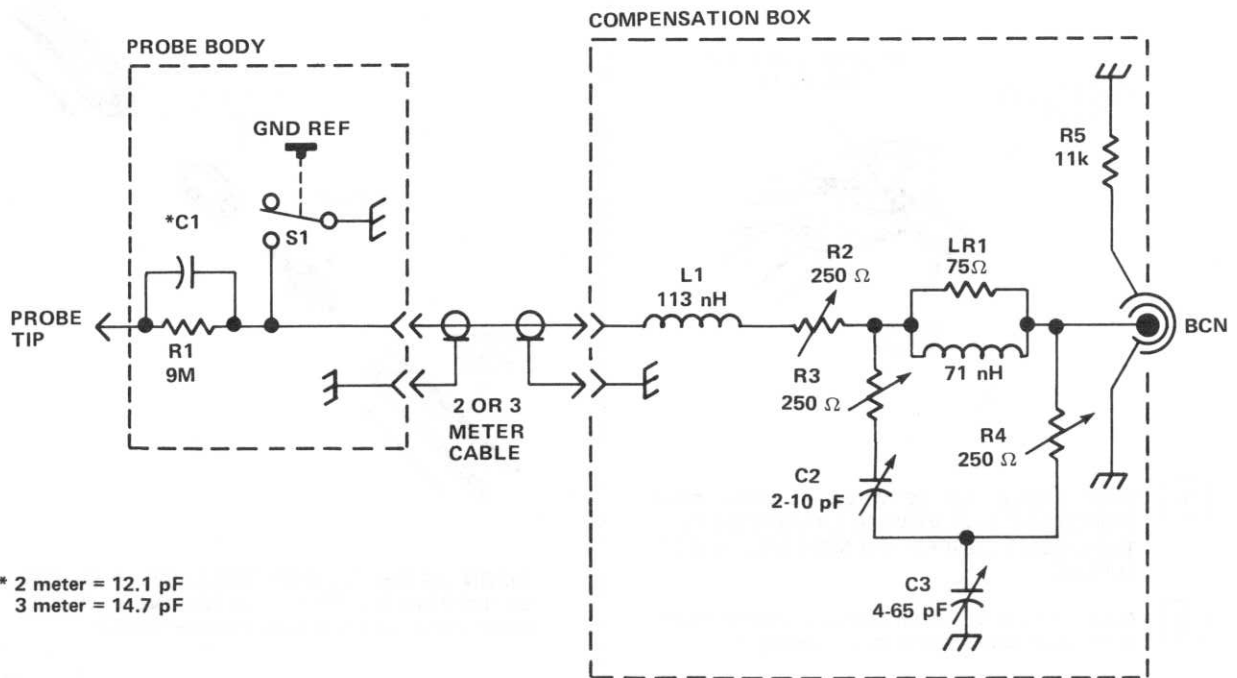

Fig. 8. Probe tip removal and replacement.

P6106 PROBE



Schematic diagram for the 1 meter probe.



* 2 meter = 12.1 pF
 3 meter = 14.7 pF

Schematic diagram for the 2 & 3 meter probes.

P6106 PROBE

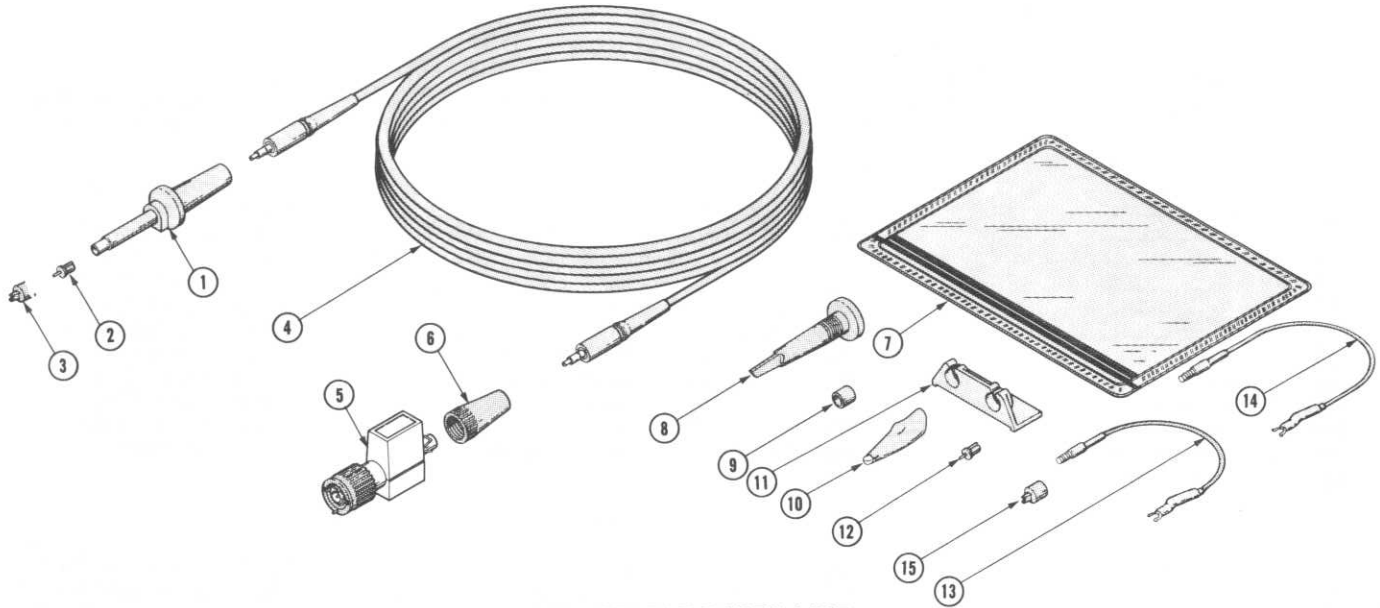

REPLACEABLE PARTS LIST

Fig. & Index No.	Tektronix Part No.	Serial/Model No. Eff	Dscont	Qty	1	2	3	4	5	Name & Description	Mfr Code	Mfr Part Number
1 METER PROBE												
										IBM Part No.		
				1						PROBE,VOLTAGE:10X,1M,W/ACCESSORIES	80009	010-6106-01
				1						. PROBE,VOLTAGE:10X,1 METER	80009	010-6106-00
-1	206-0216-00			1						. . . PROBE,HEAD:1 METER,BLUE	80009	206-0216-00
-2	-----			1					 TIP,PROBE:		
-3	-----			1					 TIP,PROBE:IC TEST		
-4	175-1661-00			1						. . . CA ASSY,SP,ELEC:1 METER,BLUE	80009	175-1661-00
-5	206-0237-00			1						. . . COMP BOX:1 METER	80009	206-0237-00
-6	343-0570-00			1					 RETAINER,COVER:COMP BOX,1 METER,BLUE	80009	343-0570-00
2 METER PROBE												
				1						PROBE,VOLTAGE:10X,2M,W/ACCESSORIES	80009	010-6106-03
				1						. PROBE,VOLTAGE:10X,2 METER	80009	010-6106-02
-1	206-0217-00			1						. . . PROBE,HEAD:2 METER,YELLOW	80009	206-0217-00
-2	-----			1					 TIP,PROBE:		
-3	-----			1					 TIP,PROBE:IC TEST		
-4	175-1661-01			1						. . . CA,ASSY,SP,ELEC:2 METER,YELLOW	80009	175-1661-01
-5	206-0238-00			1						. . . COMP BOX:2 METER	80009	206-0238-00
-6	343-0570-01			1					 RETAINER,COVER:COMP BOX,2 METER,YELLOW	80009	343-0570-01
3 METER PROBE												
				1						PROBE,VOLTAGE:10X,3M,W/ACCESSORIES	80009	010-6106-05
				1						. PROBE,VOLTAGE:10X,3 METER	80009	010-6106-04
-1	206-0218-00			1						. . . PROBE,HEAD:3 METER RED	80009	206-0218-00
-2	-----			1					 TIP,PROBE:		
-3	-----			1					 TIP,PROBE:IC TEST		
-4	175-1661-02			1						. . . CA ASSY,SP,ELEC:3 METER,RED	80009	175-1661-02
-5	206-0239-00			1						. . . COMP,BOX:3 METER	80009	206-0239-00
-6	343-0570-02			1					 RETAINER,COVER:COMP BOX,3 METER,RED	80009	343-0570-02

¹Available only in packs of 10, Part Number 206-0191-01.

²Available only in packs of 10, Part Number 015-0201-01, or 100, Part Number 015-0201-02.

Ckt No.	Tektronix Part No.	Serial/Model No. Eff	Dscont	Name & Description	Mfr Code	Mfr Part Number
1 METER PROBE						
C1 ¹	-----	-----		CAP.,FXD,CER DI:9.3PF,0.1%,500V	80009	281-0795-00
C2 ²	-----	-----		CAP,VAR,CER DI:5-25PF,100V	72982	518-000A5-25
C3 ²	-----	-----		CAP,VAR,PLASTIC:5.5-65PF,100V	80009	281-0205-00
L1 ²	-----	-----		COIL,RF:FIXED,113NH	80009	108-0733-00
L2 ²	-----	-----		SHLD BEAD,ELEK:	80009	276-0543-00
L5 ²	-----	-----		COIL,RF:FIXED,285NH	80009	108-0182-00
R1 ¹	-----	-----		RES.,FXD,FILM:9 MEG OHM,0.1%,0.25W	19647	MG660-C90003B
R2 ²	-----	-----		RES,VAR,NONWW:250 OHM,10%,0.5W	80294	3329HH78-25
R3 ²	-----	-----		RES,VAR,NONWW:250 OHM,10%,0.5W	80294	3329HH78-251
R4 ²	-----	-----		RES,VAR,NONWW:250 OHM,10%,0.5W	80294	3329HH78-25
R5 ²	-----	-----		CONN,RCPT,ELEC:BNC,FEMALE	80009	131-1799-00
R6 ²	-----	-----		RES.,FXD,CMPSN:62 OHM,5%,0.125W	01121	5905-00-879-7778
S1 ¹	-----	-----				
2 & 3 METER PROBE						
C1 ³	-----	-----		CAP.,FXD,CER DI:12.1PF,1%,500V	72982	374-001COG01219F
C1 ⁴	-----	-----		CAP.,FXD,CER DI:14.7PF,1%,500V	72982	374-001COG01479F
C2 ⁵	-----	-----		CAP,VAR,CER DI:2-10PF,100V	72982	513-001-A-2.0-10
C3 ⁵	-----	-----		CAP,VAR,PLASTIC:5.5-65PF,100V	80009	281-0205-00
LR1 ⁵	-----	-----		COIL,RF:FIXED,71NH WOUND ON 75 OHM RES	80009	108-0864-00
L1 ⁵	-----	-----		COIL,RF:FIXED,113NH	80009	108-0733-00
R1 ^{3,4}	-----	-----		RES.,FXD,FILM:9 MEG OHM,0.1%,0.25W	01121	5905-00-879-7778
R2 ⁵	-----	-----		RES,VAR,NONWW:250 OHM,10%,0.5W	80294	3329HH78-251
R3 ⁵	-----	-----		RES,VAR,NONWW:250 OHM,10%,0.5W	80294	3329HH78-251
R4 ⁵	-----	-----		RES,VAR,NONWW:250 OHM,10%,0.5W	80294	3329HH78-25
R5 ⁵	-----	-----		CAP.,FXD,CER DI:14.7PF,1%,500V	72982	374-001COG01479F
S1 ^{3,4}	-----	-----				

¹Replaceable under 206-0216-00,1 meter Probe Head.

²Replaceable under 206-0237-00,1 meter Comp Box.

³Replaceable under 206-0217-00,2 meter Probe Head.

⁴Replaceable under 206-0218-00,3 meter Probe Head.

⁵Replaceable under 206-0238-00,2 meter Comp Box or 206-0239-00,3 meter Comp Box.

Fig. & Index No.	Tektronix Part No.	Serial/Model No. Eff Dscont	Qty	1	2	3	4	5	Name & Description	Mfr Code	Mfr Part Number
ACCESSORIES											
-7	016-0521-00		1						POUCH,ACCESSORIES:	05006	OBD
-8	013-0107-03		1						TIP,TEST PROD:RET HOOK ASSY	80009	013-0107-03
-9	166-0404-01		1						INS SLV,ELEC:FOR 0.188 DIA PROBE BSHG	80009	166-0404-01
-10	344-0046-00		2						CLIP,ELECTRICAL:ALLIGATOR TYPE,W/COVER	80009	344-0046-00
-11	352-0351-00		1						HLD,TEST PROD:	80009	352-0351-00
-12	----- ¹		2						TIP,PROBE:		
-13	175-0263-01		1						LEAD,ELECTRICAL:PROBE GND,3.5 INCHES LONG	80009	175-0263-01
-14	175-0124-01		1						LEAD,ELECTRICAL:PROBE GND,5 INCHES LONG	80009	175-0124-01
-15	----- ²		1						TIP,PROBE:IC TEST		
	334-2794-00		2						BAND,MARKER:0.371 DIA,BLACK,PLASTIC	80009	334-2794-00
	334-2794-01		2						BAND,MARKER:0.371 DIA,WHITE,PLASTIC	80009	334-2794-01
	334-2794-02		2						BAND,MARKER:0.371 DIA,SILVER,PLASTIC	80009	334-2794-02
	062-1803-00		1						DATA CARD:	80009	062-1803-00
	062-2765-00		1						DATA SHEET:P6106 VOLTAGE PROBE	80009	062-2765-00

¹Available only in packs of 10, Part Number 206-0191-01.

²Available only in packs of 10, Part Number 015-0201-01, or 100, Part Number 015-0201-02.

CROSS INDEX—MFR. CODE NUMBER TO MANUFACTURER

Mfr. Code	Manufacturer	Address	City, State, Zip
01121	ALLEN-BRADLEY COMPANY	1201 2ND STREET SOUTH	MILWAUKEE, WI 53204
05006	TWENTIETH CENTURY PLASTICS, INC.	415 E WASHINGTON BLVD.	LOS ANGELES, CA 90015
19647	CADDOCK ELECTRONICS INC.	3127 CHICAGO AVENUE	RIVERSIDE, CA 92507
72982	ERIE TECHNOLOGICAL PRODUCTS, INC.	644 W. 12TH ST.	ERIE, PA 16512
80009	TEKTRONIX, INC.	P O BOX 500	BEAVERTON, OR 97077
80294	BOURNS, INC., INSTRUMENT DIV.	6135 MAGNOLIA AVE.	RIVERSIDE, CA 92506

