

**TYPE 5T3  
TIMING UNIT**

Written and Produced in Field Training

Material in this Training Package is

**COMPANY CONFIDENTIAL**  
—  
**FOR INTERNAL USE ONLY**

Project Manager . . . . . Al Zimmerman  
Project Engineer (E) . . . . . George Frye  
Project Engineer (M) . . . . . Dick Swanson  
Evaluation Engineer (E) . . . . . Tom Charters  
Evaluation Engineer (M) . . . . . Jesse Chappell

## TABLE OF CONTENTS

I	INTRODUCTION	
	GENERAL INFORMATION-----	1-1
	SPECIFICATION #116-----	1-3
	Prepared by Technical Writing Dept., Engineering Product Evaluation	
	COMPETITIVE INFORMATION-----	1-10
	Paul J. Whitlock, Product Information	
	CONTROLS & CONNECTORS-----	1-13
	HOW THE FRONT PANEL PLAYS-----	1-20
	FRONT PANEL VAGARIES-----	1-35
	FRONT PANEL GOOD GUY-----	1-42
II	GENERAL BLOCK DISCUSSION	
	TYPE 5T3 BASIC BLOCK DIAGRAM-----	2-3
	PSEUDO SCHMITT-----	2-9
	SHORT FORM CALIBRATION PROCEDURE-----	2-17
III	BLOCK DISCUSSION	
	EXTERNAL TRIGGER INPUT-----	3-3
	TRIGGER GENERATOR-----	3-5
	EQUIVALENT TIME RAMP GENERATOR-----	3-19
	REGENERATOR-----	3-25
	STAIRCASE GENERATOR-----	3-29
	REAL TIME CLOCK-----	3-37
IV	5T3 TRAINING CALIBRATION PROCEDURE-----	4-1
V	SCHEMATICS AND EC BOARD PULL-OUTS	



## TYPE 5T3 TIMING UNIT

The Type 5T3 is an extremely wide range timing unit for use in the Type 661 Sampling Oscilloscope. It was developed to provide a time base that would more fully utilize the capabilities of the sampling plug-in unit. The sampling plug-ins are essentially chopper stabilized amplifiers with a passband from DC to frequencies as high as 3.5 GC (4S2).

The 5T3 utilizes the full passband of the sampling plug-in by incorporating real time and equivalent time sampling techniques in the same time base. Real time calibrated sweep rates from 5 sec/cm to .2 msec/cm and equivalent time calibrated sweep rates from 100  $\mu$ sec/cm to 10 psec/cm are available in a 1, 2, 5 sequence. VARIABLE controls provide an increase in calibrated sweep rates by a factor of at least 2.5:1. The slowest sweep rate available is 5 sec/cm and the fastest sweep rate available is about 3 psec/cm (roughly 10 times the speed of light).

Equivalent time sampling is similar to the type used in the 5T1A. The equivalent time control is constructed to provide direct readout time magnification.\* (The EQUIVALENT TIME/CM control is the same mechanical type device that is used to provide direct readout magnification on the 3B4.) Time magnification from X1 to X100 is available. A TIME POSITION control allows various portions of the time window to be displayed on the crt. Front panel operation of the direct readout mag and the TIME POSITION control can be compared to the A DELY'D BY B mode of the 545A. A SAMPLES/CM control provides the same dot density capabilities as the 5T1A.

Real Time sampling rates are 100 KC and a 60 cps FM modulated rate with a period not shorter than 10  $\mu$ sec. The real time display is in the form of dots. The 60 cps modulated rate provides a method of checking and correcting for false displays in the sampling information presented on the crt. Real time sweep magnification is provided by the Sweep Magnifier on the 661 main frame. No Time Position or Dots/cm controls are provided for real time. Dot density is a function of the sampling rate, real time sweep rate, and the 661 Sweep Magnifier.

\*Termed Time Expansion in the 5T1A.

Repetitive or single displays can be selected. A single display is initiated by jabbing the START button.

The decision to build a real time sampling unit required the development of a Schmitt type trigger. The Schmitt type trigger also answers the need for a trigger circuit whose controls do not necessarily require adjustment with a change in input amplitude. The Schmitt type trigger is operative from DC to 500 MC with at least a 5 mv input. For fast, short signals or with HF rep rates up to 500 MC, an AUTO RECOVERY mode is provided. An UHF SYNC mode provides triggering from 500 MC to 5 GC, with an external input only. The trigger controls, LEVEL, STABILITY, SLOPE, and SOURCE, are operated in a manner which conjures memories of a 545A.

Internal, External, or Calibrator trigger inputs are selected by the SOURCE control. A free run position is provided to help get things on screen. AC or DC coupling for internal signals is selected at the vertical plug-in. The calibrator signal is AC coupled.

Two external input jacks are provided. One, a BNC connector, feeds a high impedance, 1 Meg  $\Omega$  shunted by approximately 30 pf, and the other, a GR connector, feeds a 50 $\Omega$  terminated input. AC or DC coupling can be selected for either mode. UHF SYNC signals are applied through the 50 $\Omega$  terminated input.

The Delayed Pulse output of the 661 should be checked when a 5T3 is used. The Delay Pulse Generator in the 661 may require readjustment.

## SPECIFICATION #116

## 1.0 Performance Requirements

## 1.1 Electrical Characteristics

The following electrical characteristics are valid throughout the environment specified in Section 1.2 unless there is a statement to the contrary.

The following codes are used to categorize performance requirements:

- G (General Use) This performance requirement may, but not necessarily will, be quoted to a customer.
- I (Internal Use Only) This performance requirement will not be quoted to a customer.
- A (All) It is recommended by Engineering that electrical testing of this performance requirement be performed on 100% of instruments. Environmental testing is performed on a sample basis.
- S (Sampled) This performance requirement carries a high level of confidence and may be tested electrically and environmentally on a sample basis.
- \*T (Traceable) Test equipment and test method used to measure this performance requirement are traceable to the National Bureau of Standards, to the limit of the Bureau's calibration facilities.
- \*N (Nontraceable) Cannot be traced to National Bureau of Standards.

Each performance requirement in this section will be coded in combination as listed below:

GA-T: General Use --- 100% testing --- Traceable

GA-N: General Use --- 100% testing --- Nontraceable

GS-T: General Use --- Sampled --- Traceable (can be certified, requiring 100% testing, at additional cost to the customer)

GS-N: General Use --- Sampled --- Nontraceable

IA: Internal Use Only --- 100% testing

IS: Internal Use Only --- Sampled

- \* These codes obtained by, and the responsibility of, Technical Writing Department of Preproduction Engineering.

## 1.2 Environmental Characteristics

The Type 5T3 is a laboratory instrument. The following environmental limits apply.

### 1.2.1 Storage

No visible damage or electrical malfunction after storage at  $-40^{\circ}\text{C}$  to  $+65^{\circ}\text{C}$  and 50,000 feet, as described in Sections 4.1 and 4.2. Adjustments may be performed to meet required accuracy after storage tests.

### 1.2.2 Temperature

The instrument will perform to limits indicated in Section 1.1 over a range of  $0^{\circ}\text{C}$  to  $+50^{\circ}\text{C}$  when tested according to Section 4.1.

### 1.2.3 Altitude

The instrument will perform to limits indicated in Section 1.1 to 15,000 feet.

### 1.2.4 Vibration

The instrument will perform to limits indicated in Section 1.1 following vibration tests described in Section 4.3.

### 1.2.5 Transportation

The instrument will be so packaged that it will meet the National Safe Transit requirements described in Section 4.4.



TRIGGER SYSTEM

Characteristic	Performance Requirement	Code	Supplemental Information
<u>External 50-<math>\Omega</math> Input</u>			
Coupling	AC, DC, and UHF Sync	GS-N	Lower 70% amplitude point ( $\approx$ 3 db down) for AC coupling is 500 kc, and for UHF Sync is 1 gc.
Input Resistance	50 $\Omega$ + 7% - 5%	GA-T	Input R remains at 50 $\Omega$ level regardless of coupling.
Dynamic Range	$\pm$ 5 mv to 150 mv	GS-T	
Maximum Overload			$\pm$ 5 v
<u>Triggering Frequency Range</u>			Lower frequency limits refer to sinewaves only. Frequency range verified in Trigger jitter tests.
DC Coupling	DC to 500 mc	GA-T	
AC Coupling	500 kc to 500 mc	GA-T	
UHF Sync Coupling	500 mc to 5 gc	GA-T	
<u>External 1-Megohm Input</u>			
Coupling	AC or DC	GA-N	Lower 70% point for AC coupling: 160 cps (coupled through 0.001 $\mu$ f capacitor).
Input Resistance	1 megohm $\pm$ 20%	GA-T	Shunted by $\approx$ 30 pf
Dynamic Range	$\pm$ 50 mv to 1.5 v	GS-T	
Maximum Overload			$\pm$ 100 v

## TRIGGER SYSTEM (continued)

Characteristic	Performance Requirement	Code	Supplemental Information
Triggering Frequency Range	DC to 20 mc (DC), 160 cps to 20 mc (AC)	GA-T	AC lower frequency limit refers to sinewaves only. Frequency range verified in trigger jitter tests.
<u>Internal Triggering</u>			
Coupling	DC	GS-N	AC or DC coupling selected in vertical unit.
Frequency Range		GS-T	DC to $\approx$ 1 gc
Trigger Circuit Recovery Time		GS-T	Typically 12 $\mu$ sec. Slower on sweep rates below 0.1 $\mu$ sec/cm.
Real Time	$\geq$ 10 $\mu$ sec		
Equivalent Time	$\geq$ 10 $\mu$ sec, or $\geq$ 4X Time Position Range	GA-T	
<u>Trigger Jitter</u>			
Equivalent Time (External UHF Sync Mode)	$\leq$ 70 psec for 2 gc, 5 mv $\leq$ 70 psec for 5 gc, 10 mv $\leq$ 30 psec for 5 gc, 50 mv $\leq$ 30 psec for 2 gc, 10 mv	GA-T	Checked with 20 nsec time-position ramp, using sine-wave trigger-input signal. Voltage values are peak-to-peak.
Equivalent Time (Auto Recovery)	$\leq$ 300 psec for 5 mv at 500 mc applied to 50- $\Omega$ external input, or 40 mv at 500 mc applied to 4S1 with internal triggering. $\leq$ 70 psec for 50 mv at 500 mc applied to 50- $\Omega$ external input, or 400 mv at 500 mc applied to 4S1 with internal triggering.	GA-T	

TRIGGER SYSTEM (continued)		
Characteristic	Performance Requirement	Code
Pulse Triggering (Auto Recovery or Schmitt)	<p>≤ 300 psec for 5 mv at 50-Ω external input or for 40 mv at 4S1 input with internal triggering, ≤ 100-kc repetition rate.</p> <p>≤ 30 psec for 50 mv at 50-Ω external input or 400 mv at 4S1 input with internal triggering, ≤ 100-kc repetition rate.</p>	GA-T
		Supplemental Information
		Pulse shape: 2 nsec wide at 50% amplitude points, 1 nsec or less risetime. Checked with 20 nsec time-position ramp.

SWEEP SYSTEM

Characteristic	Performance Requirement	Code	Supplemental Information
<u>Strobe Period</u>			
<u>Equivalent Time</u>	≥ 10 μsec	GS-T	
Real Time (calibrated rate)	10 μsec ±1%	GA-T	Set by IC controlled oscillator
Real Time (random rate)	10 μsec minimum; 15 μsec maximum	GA-T	60 cycle modulated
<u>Calibrated Sweep Rates</u>			
<u>Equivalent Time</u>	10 psec/cm through 100 μsec/cm	GA-T	In 1-2-5 sequence
Real Time	0.2 msec/cm to 5 sec/cm	GA-T	In 1-2-5 sequence
<u>Sweep Rate Accuracy</u>			
<u>Basic Accuracy</u>	± 3%, real time or equivalent time		
Real Time	Exclude first 20 μsec		All real-time sweep rates
<u>Equivalent Time</u>			
<u>Time-Position Range</u>			
20 nsec	Exclude first 3 nsec of ramp	GA-T	
100 nsec	Exclude first 10 nsec of ramp		
1 μsec	Exclude first 40 nsec of ramp		
10 μsec, 100 μsec and 1 msec	Exclude first portion of ramp equal to 1.5% of the time-position range		

SWEEP SYSTEM (continued)			
Characteristic	Performance Requirement	Code	Supplemental Information
Variable Range	$\geq 2.5:1$	GS-T	Real Time or equivalent time
<u>Display Jitter</u>			
Real Time	$\leq 1 \mu\text{sec}$ , for 100 kc Cal triggering and $\leq 10 \mu\text{sec}$ for 1 megohm external triggering	GS-T	Triggering on 200mv, 1-kc signal from a square-wave calibrator (amplitude calibrator of 530-540 series oscilloscope).
<u>Equivalent Time</u>			
20 nsec Time-Position Range	$\leq 30 \text{ psec}$	GA-T	Triggering on pulse 2 nsec wide at 50% amplitude and risetime of 1 nsec or less, 400 mv p-p applied to 4S1 with internal triggering used
100 nsec Time-Position Range	$\leq 40 \text{ psec}$	GA-T	
1 $\mu\text{sec}$ , 10 $\mu\text{sec}$ , 100 $\mu\text{sec}$ and 1 msec Time-Position Ranges	$\leq 2 \times 10^{-4}$ of total ramp duration	GA-T	

COMPETITION: Below is a comparison chart for the 5T3 and some of the more competitive Sampling Time Bases

	5T3	5T1A	Lumatron Model 2170	H.P. 185B
trigger modes	TD Schmidt - for normal TD one shot for hi freq sync 50Ω input Z	TD one shot 50Ω input Z	TD one shot 100Ω input Z	TD one shot 50Ω input Z
trigger freq range	DC to 5 KMC	DC to 1 KMC	To 3 KMC (DC external)	to > 1 KMC
trigger sensitivities	5 mv	5 mv, 2 nsec wide pulse	5-10 mv, 2 nsec wide pulse	15 to 200 mv, 5 nsec wide pulse
Sweep Speeds (equivalent time)	100 μsec to 10 psec (±3%) (see below for real time)	100 μsec to 10 psec (±3%)	100 μsec to 10 psec (±3%)	10 μsec to 100 psec (±5%)
Delay Ranges	Range indicated on front panel -- (20 nsec to 1 msec)	Various ranges not indicated -- (10 nsec to 1 msec)	Not indicated fixed 10 and 20 nsec X2 screen diameters 20 msec to 2 nsec	Not indicated 1 screen diameter
Samples/cm	5, 10, 20, 50, 100, 1000 timed	5, 10, 20, 50, 100, 1000 timed	5, 10, 20, 50, 100	Continuous ≈ 7-100 samples/cm
Real time sampling capability	200 μsec/cm to 5 sec/cm in 1, 2, 5 steps (1 megΩ input Z) Display is dots	None	1 msec/cm and 10 msec/cm ranges only (100Ω input Z) Display is 10 μsec slashes	None
Price	\$ 900	\$ 750	\$ 750	Part of main frame priced at \$ 2000



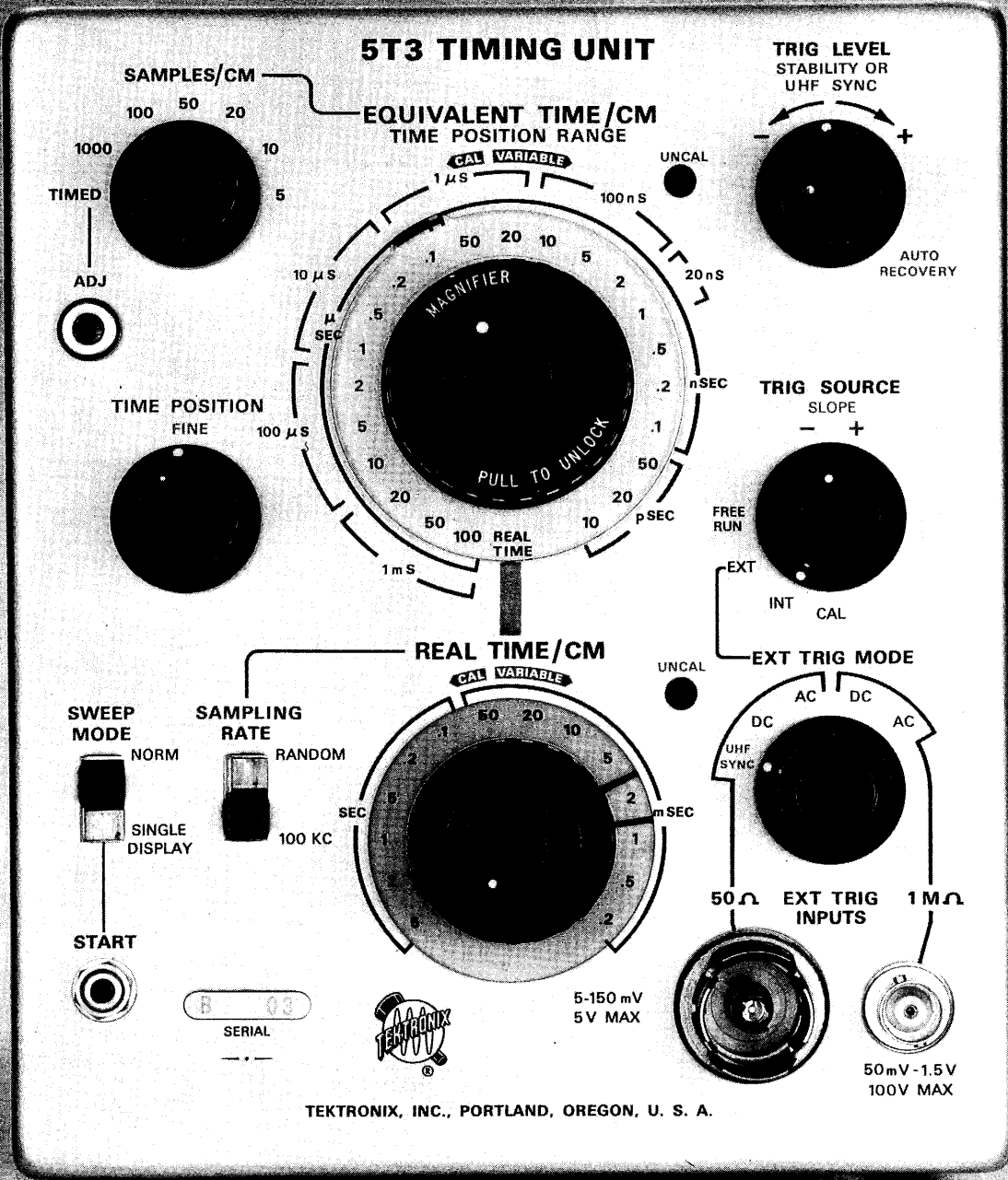



## CONTROLS AND CONNECTORS

TRIGGER

TRIG LEVEL (black knob):

Adjusts threshold of TD Pseudo Schmitt. When the STABILITY is set at approximately 12 o'clock and the SLOPE is set to +, a slight adjustment of the LEVEL in the - (minus) direction (CCW) will cause the sweep to free run. If the SLOPE is set to -, a slight adjustment from 12 o'clock in the + direction (CW) will cause the sweep to free run. Larger adjustments cause the sweep to stop again.

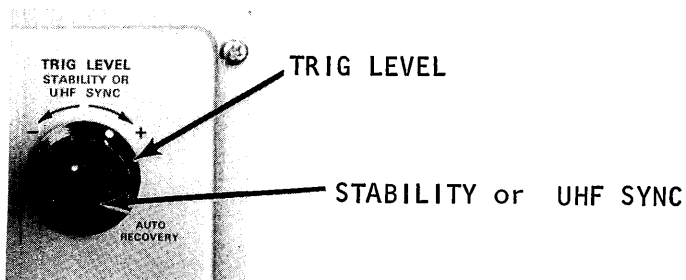

STABILITY OR UHF SYNC (red knob):

Adjust upper and lower command levels (hysteresis width) of the Pseudo Schmitt. If set CW from 12 o'clock, sweep can free run with proper adjustment of the TRIG LEVEL control. If set anticlockwise from 12 o'clock, sweep shuts down.

In UHF SYNC, adjusts threshold current (low state bias) of one shot TD trigger regenerator.

If control is rotated fully CW, into its detent (like click), AUTO RECOVERY mode is selected for Pseudo Schmitt trigger, except in UHF SYNC.

**SLOPE: (red knob)**

Allows selection of + and - slope by controlling the phase of the signal applied to the Pseudo Schmitt.

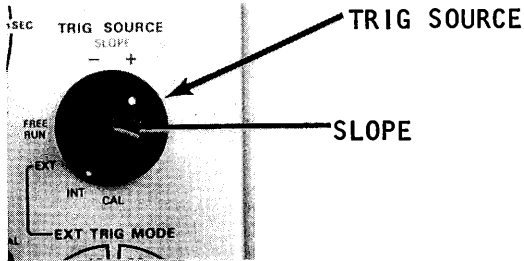
**TRIG SOURCE (black knob):**

Selects CAL, EXT, INT, or FREE RUN.

**FREE RUN:** Provides method of finding trace.

**INT:** Available with 4S1 only. AC or DC coupling selected in the 4S1.

**CAL:** Provides 100 mv AC coupled signal.

**EXT:** Provides a variety of signal couplings which are selected by the EXT TRIG MODE control.

**EXT TRIG MODE:**

Selects high impedance or 50Ω terminated inputs.

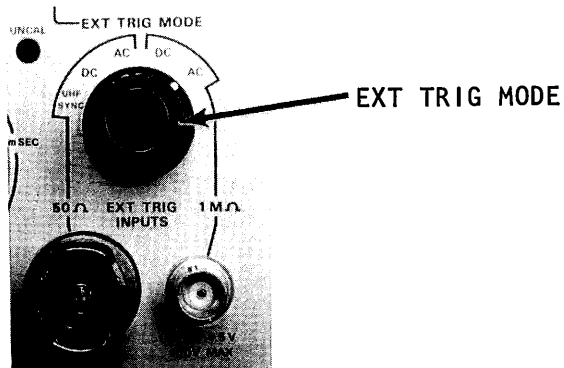

**HIGH IMPEDANCE:** 1 Meg shunted by approximately 30 pf. AC or DC coupling.

DC: DC to approximately 20 MC.

AC: 160 cps (.001  $\mu$ f coupling cap) to approximately 20 MC.

50 mv to 1.5v p-p, 100v max. overload.

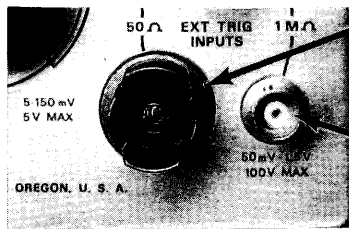

AC, DC or UHF SYNC coupling  
to 5 GC

AC or DC coupling  
to 20 MC

**50 $\Omega$  TERMINATION:** 50 $\Omega$  +7%, -5%, input R remains at 50 $\Omega$  regardless of coupling. AC, DC, or UHF SYNC coupling.

DC: DC to 500 MC.

AC: 500 KC to 500 MC.

UHF SYNC: 1 GC (70% down) to 5 GC. (Usable to below 500 MC)

5 mv to 150 mv p-p. 5v max. overload.

EQUIVALENT TIMEEQUIVALENT TIME/CM:

A mechanical complex which includes the EQUIVALENT TIME/CM readout, direct readout TIME MAGNIFIER, and TIME POSITION RANGE indicator. This is the same mechanical control that is used in the 3B4. Manipulation and interpretation of this device requires some thought and therefore will be explained in a special section. See page 1-20

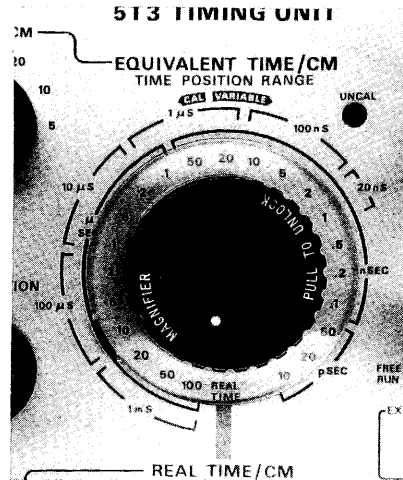
VARIABLE:

Provides an increase of sweep rate by a factor of at least 2.5:1. When switch is rotated CW from the CAL position, the UNCAL neon comes on.

SAMPLES/CM:

Selects 5, 10, 20, 50 100, 1000, and TIMED.

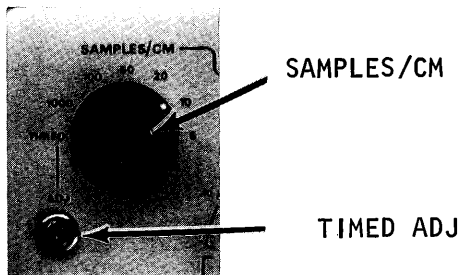
Timed Adj.:

A screwdriver adjustment which controls the scan rate in the TIMED position. When set full CCW, sweep rate must be slower than 5 sec/CM and when set full CW, sweep rate must be faster than .5 sec/CM.

**TIME POSITION:**

A COARSE (black knob) and a FINE (red knob) control which selects the portion of the time window that is displayed on the CRT. See special section on the EQUIVALENT TIME/CM control which begins on page 1-20

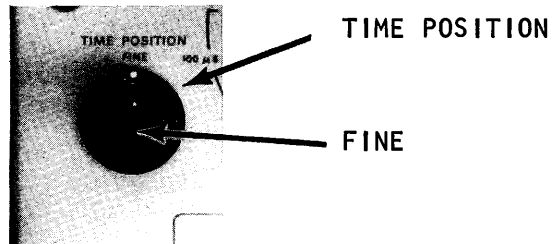
**REAL TIME****REAL TIME/CM:**

Selects the REAL TIME/CM sweep rate.

**VARIABLE:**

Provides an increase in sweep rate by a factor of at least 2.5:1. When switch is rotated CW from the CAL position, the UNCAL neon comes on.

**SAMPLING RATE:**

Selects 100 KC or RANDOM (60 cps FM modulated) rate for real time sampling.

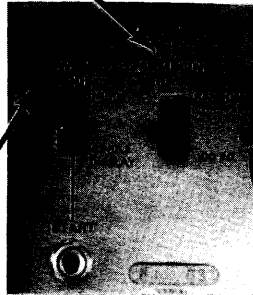

**SWEEP**

**SWEEP MODE:**

Selects NORM (repetitive) or SINGLE DISPLAY.

**START:**

Single display is initiated by pressing START button.

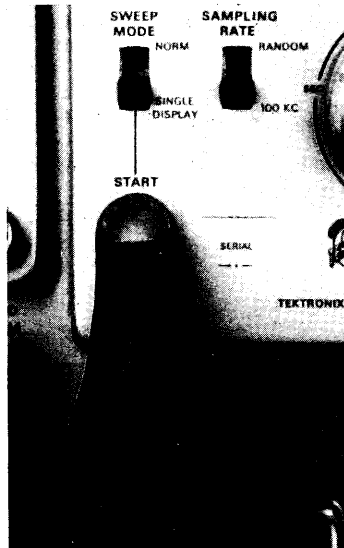
**CONNECTORS****BNC:**

High Impedance external trigger input.

**GR:**

50 $\Omega$  terminated external trigger input.

## HOW THE FRONT PANEL PLAYS

Unfortunately, there is a problem which is inherent in the design of the 5T3. The problem is that the operator will be required to think to operate the front panel controls correctly. If the operator wishes to utilize the complete capabilities of this box, he may even need to think clearly (a constant source of irritation in itself). The following discussion concerns manipulation and interpretation of the front panel controls.

### TRIGGERING

The 5T3 has three distinct trigger modes. They are Pseudo Schmitt, Auto Recovery, and UHF Sync.

#### PSEUDO SCHMITT

The TRIG LEVEL, STABILITY and SLOPE controls govern the operation of the Pseudo Schmitt trigger. Other controls, like the TRIG SOURCE and EXT TRIG MODE, tell us how the signal gets to the Schmitt, but they do not control the operation of the Schmitt. Our interest in the SLOPE control is due to its affect on the TRIG LEVEL, not its control on the Schmitt.

We will assume the trigger circuits are properly adjusted, as described in the Training Calibration Procedure, and that the scope has been running for about 15 minutes to allow the "thermals" time to settle down.

1. Before we apply an input signal and tweak for a stable display, we will, of course, have to play with the controls to get the feel of things.
  - a. Set the SLOPE to - (minus), the TRIG LEVEL full CCW, and STABILITY to 12 o'clock. There should not be a display on the crt.
  - b. If we set the STABILITY to 2 o'clock and slowly rotate the TRIG LEVEL CW, the trace should free run as the TRIG LEVEL is set at approximately 12 o'clock. (No fair setting the TRIG SOURCE to FREE RUN.) If the TRIG SOURCE is set to CAL and the 661 Calibrator is turned on, this ain't gonna work the way what we say it does.



- c. We can shut the sweep down (1) by rotating the TRIG LEVEL full CW or full CCW. (2) by rotating the STABILITY CCW towards 12 o'clock, or (3) by setting the SLOPE to + (plus).
- d. If we set the SLOPE to + and the STABILITY to 2 o'clock, we can cause the sweep to free run by rotating the TRIG LEVEL slightly CCW from 12 o'clock. We can turn the sweep off (1) by rotating the TRIG LEVEL full CW or full CCW, (2) by rotating the STABILITY CCW towards 12 o'clock, or (3) by setting the SLOPE to - (minus).

The STABILITY control sets the hysteresis width of the Pseudo Schmitt. The TRIG LEVEL control sets the threshold level of the Pseudo Schmitt. As we have seen, it is possible to adjust these controls so the hysteresis width and threshold level overlap, which can cause the TD Schmitt to flip and produce a free running sweep. The SLOPE control reverses the DC voltages applied to the TRIG LEVEL pot. When we go to - SLOPE, the TRIG LEVEL control feels "right". The box has been "human engineered" to give the feel of a 540 type scope.

2. Let us assume we are applying 800 mv at 1 MC from a Type 190B. We will further assume that this signal is within the passband specs and is attenuated to be within the minimum-maximum amplitude specs for whichever coupling-source combination we choose.
  - a. Set the SLOPE to + and the TRIG LEVEL and STABILITY to 12 o'clock. Now set the STABILITY CW until the sweep free runs; then back off just past the free running point. (The sweep may appear to be "triggered" or it may disappear.)
  - b. Adjust the TRIG LEVEL for a stable display.
  - c. Set the SLOPE to - and, if necessary, readjust the TRIG LEVEL (and possibly the STABILITY) for a stable display. When the sweep is 'triggered', we can switch from + to - SLOPE and maintain a stable display WITHOUT an adjustment of the trigger controls.

- d. As noted previously, it is possible to free run the sweep at various TRIG LEVEL and STABILITY settings. To insure we are not synced to a free running sweep in either + or - SLOPE, remove the trigger signal. Switch the SLOPE from + or -, and check for no display.
- e. When the trigger controls are properly adjusted, a stable display will be obtained in + and - SLOPE and the sweep will shut down in + and - SLOPE when the trigger signal is removed.

### AUTO RECOVERY

The Auto Recovery mode was included to provide stable triggering for fast, low energy pulses with rep rates up to 500 MC. In this mode, the Pseudo Schmitt circuitry acts as a one-shot multi. The one-shot multi feeds an output TD. This mode will operate similar to the trigger recovery logic of the 5T1A. If the TRIG LEVEL is adjusted for a coherent countdown, in phase triggering will result. To select Auto Recovery, the STABILITY control is rotated fully CW into its detent. The SLOPE control affects the TRIG LEVEL as it did in the Pseudo Schmitt mode.

The Auto Recovery mode can be said to operate halfway between Schmitt type triggering and UHF Sync. The Department of Descriptive Terminology might say we are synced to a semi-free running sweep. We can insure the sweep is not free running by removing the trigger signal. We can not expect the display to remain stable while switching the SLOPE control. This mode works well with small energy trigger pulses, but you can run into false display problems with long duration pulses, square waves, and LF sine waves. A small energy pulse would be something like 10 mv from a Type 111 without a charge line (approx. 2n secs wide).

### UHF SYNC

UHF Sync provides triggering for signals from 500 MC to 5 GC. In this mode the trigger signal is fed directly to a one-shot TD oscillator. The STABILTIY control adjusts the threshold of the one-shot TD to provide a coherent countdown. The input signal is synced to a free running sweep.

1-23

NOTES

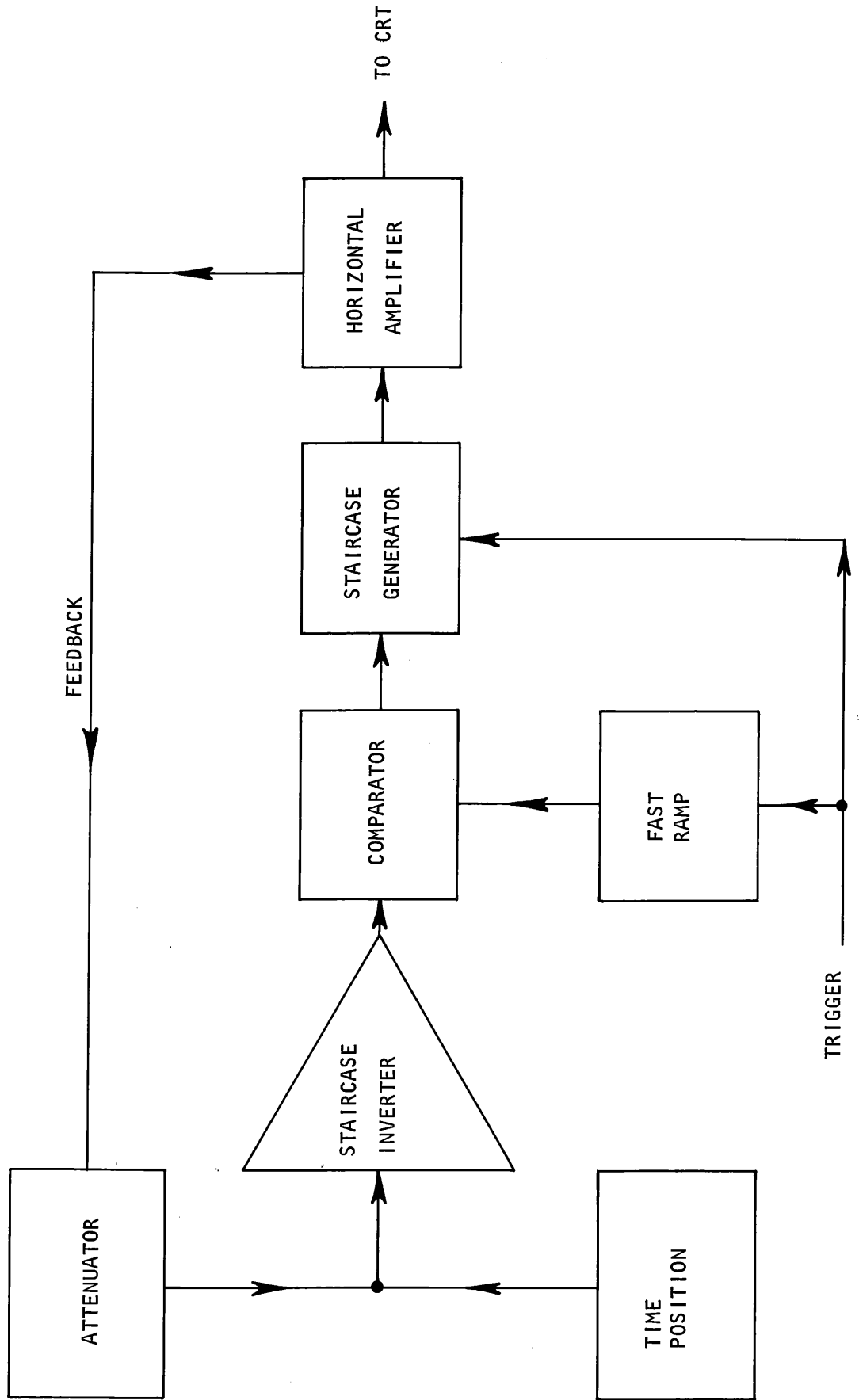

SAMPLING TIME BASE BASIC BLOCK DIAGRAM

Figure 1-1

## EQUIVALENT TIME READOUT

To better understand what is accomplished by manipulating the EQUIVALENT TIME/CM control, let us briefly review the generation of a sweep in the 661 sampling scope. Figure 1-1 shows the basic block diagram of a sampling time base.

The purpose of the time base is to provide a time reference signal. This time reference signal in conjunction with the samples of the input signal form a composite waveform which is a replica of the signal applied to the vertical plug-in.

To form an exact replica of the input signal, we must take samples at a number of points along the input. The simplest way is to sample in a direct line as opposed to random sampling. In the present method of sampling, samples are taken successively along the input signal.

The following is a chronological list of the events which occur as a time reference signal is generated. All the circuits are in their quiescent state, awaiting a trigger pulse which will initiate the sampling process.

1. A trigger is generated.
2. The trigger is sent to the Fast Ramp circuit and the Staircase Generator.
  - a. The trigger unlocks the Staircase Generator and allows it to receive an input signal.
  - b. The trigger causes a fast ramp (sawtooth type signal) to be generated. The fast ramp is the time reference for the input signal and is much the same as the Miller sweep of a real time scope.
3. The fast ramp signal fires the Comparator.
  - a. Since we are at the start of the sweep, there is no feedback from the Horizontal Amplifier to affect the firing point of the Comparator.
  - b. For the present we will ignore the affect of the TIME POSITION control.

- c. Since we are only concerned with the affect of the fast ramp signal on the Comparator, we will assume the Comparator fires coincidentally with the start of the fast ramp.
4. The Comparator sends a signal to the Regenerator and may also reset the Fast Ramp. (The Fast Ramp can be reset by the Trigger Generator.)
5. The Regenerator fires.
  - a. A signal is sent to the vertical which causes a sample to be taken. This signal is termed an interrogate pulse (or stroke pulse).
  - b. The Regenerator also sends a signal to the Staircase Generator which causes it to make one step.
6. The size of the step taken by the Staircase Generator is determined by circuitry within the Staircase Generator. The Regenerator only tells the Staircase Generator to step; it cannot tell the Staircase Generator what size step to take.
7. The output of the Staircase Generator is sent to the Horizontal Amplifier.
8. The Horizontal Amplifier signal is applied to the crt. A portion of the signal in the Horizontal Amplifier is fed back to the Comparator through the Staircase Inverter.
9. The output of the Staircase Inverter opposes the Fast Ramp signal.
  - a. Before the Comparator can fire, the Fast Ramp signal must overcome the offset signal that has been applied by the Staircase Inverter.
  - b. The amplitude of the offset signal is proportional to the size of the step taken by the Staircase Generator.
10. When a second trigger is generated, it again is sent to the Fast Ramp and the Staircase Generator.
  - a. Since the Staircase Generator is unlocked, it will not see the new trigger signal. The only time the trigger affects the Staircase Generator is when the Staircase Generator is in its quiescent state and is ready to be unlocked.

11. The Fast Ramp again generates the time reference sawtooth signal.
  - a. The Fast Ramp must run for a longer period before the Comparator will fire. The Comparator will not fire until the Fast Ramp signal has overcome the offset signal from the Staircase inverter.
12. The Comparator signal is again applied to the Regenerator and the Regenerator supplies the interrogate pulse for the vertical and the step signal to the Staircase Generator.
13. The Staircase Generator steps and applies a signal to the Horizontal Amplifier which is amplified and sent to the crt.
14. The feedback signal from the Horizontal Amplifier will increase proportionally to the size of the step taken by the Staircase Generator.
15. Since the feedback signal has increased, the Fast Ramp must run even longer before it can overcome the feedback signal.
16. This sequence will repeat itself until the Staircase Generator has stepped up to the point where it will unlatch and reset (10.5 cm of sweep). The unlatching and resetting of the Staircase Generator is similar to the resetting of the sweep generator in a real time scope.

We can also describe the events outlines above in terms of time. For example, we will select an EQUIVALENT TIME readout of  $10 \mu\text{sec}/\text{cm}$  to be displayed at  $10 \text{ samples}/\text{cm}$ . A trigger is necessary for each sample and the time of the trigger pulse will be labeled  $T_0$ .

Thus we have:

$T_{01}$  : First trigger - Staircase Generator is unlocked and Fast Ramp is started.

$T_1$  : First sample - Staircase Generator steps - feedback is applied to Comparator through the Staircase Inverter.

$T_{02}$  : Second trigger - Fast Ramp started.

$T_2$  : Second sample - the time/cm and samples/cm combination dictate that the Fast Ramp must run  $1 \mu\text{sec}$  longer before the second sample is taken.

$T_{03}$  : Etc.

We have now reached the point where we can no longer successfully ignore the Time Position block. The TIME POSITION control provides a DC bias to the Comparator which opposes the Fast Ramp signal. This DC bias actually controls the length of time the Fast Ramp must run before the first sample can be taken. The TIME POSITION control is actually a delay type control in that it controls the time between the first trigger pulse and the first sample. After the first sample, the other samples will be spaced as described above. The TIME POSITION control determines when the first sample will be taken and the feedback signal from the Staircase Inverter determines the length of each Fast Ramp excursion.

It might now be appropriate to say how these conditions are effected from the front panel. The EQUIVALENT TIME/CM control has two indicators. The first indicator is the blue rectangle on the clear plastic skirt and the second indicator is the white dot on the black knob. The blue rectangle indicates the amount of Time Position (time window or delay) that is available and it also indicates which ramp slope is used. The white dot always indicates the Equivalent Time/cm Readout on the crt. A comparison of the settings of the two indicators shows the magnification factor.

Let us set the blue rectangle and the white dot so they are aligned at 10  $\mu$ sec/cm. The blue rectangle is within the 100  $\mu$ sec blue bracket that is scribed around the perimeter of the clear plastic skirt. The white dot is aligned with 10  $\mu$ sec as read through the clear plastic skirt. See figure 1-2.

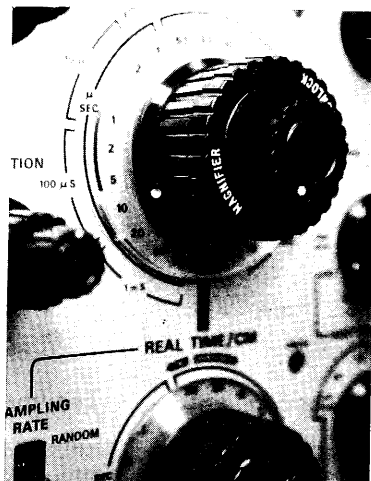

Figure 1-2



We have the following information with this set-up.

1. The delay that can possibly be introduced by the TIME POSITION control is 100  $\mu$ sec. Delay increases as the control is set from full CW (minimum) to full CCW (maximum).
2. The Equivalent Time/cm Readout on the crt is 10  $\mu$ sec/cm.
3. When the indicators are aligned, the magnification factor is 1.
4. We are using what is termed the 100  $\mu$ sec ramp slope.

We can obtain an Equivalent Time/cm Readout of 5  $\mu$ sec with the 100  $\mu$ sec ramp slope in two ways. The first is to rotate the EQUIVALENT TIME/CM control one position to the right. Both the black knob and the clear plastic skirt will be rotated. The second is to PULL OUT the MAGNIFIER (black knob) until it unlocks from the clear plastic skirt. Now rotate the black knob one position to the right. The clear plastic skirt will not move. See Figure 1-3 A and B.

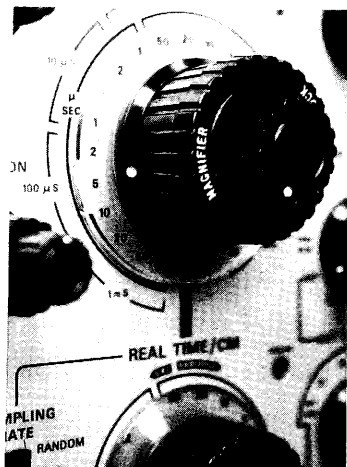

(A)

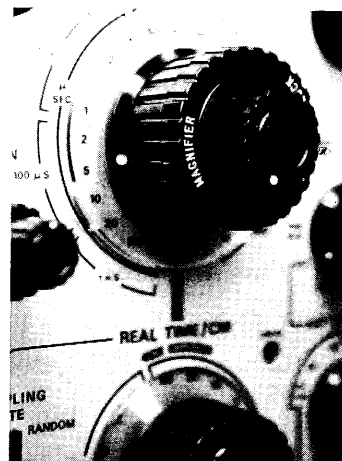

(B)

Figure 1-3

Mechanically we have performed two different tasks but electrically, the results are the same. The circuitry of the 5T3 cannot differentiate between these two operations. In each case we are using the same 100  $\mu$ sec ramp slope (the blue rectangle is within the 100  $\mu$ sec blue bracket). The delay capabilities of the TIME POSITION are the same. In both cases, rotating the white dot one position to the right has changed the feedback signal from the Staircase Inverter to the Comparator.

With a sweep length of 10.5 cm, 105 samples must be taken to complete one sweep. For the last sample, the Fast Ramp must run 105  $\mu\text{sec}$  longer than it did to take the first sample. In this example the equivalent time between samples is 1  $\mu\text{sec}$ . If we had 100 samples/cm, the equivalent time between samples would be 0.1  $\mu\text{sec}$ . To take the last sample, the fast ramp must still run 105  $\mu\text{secs}$ . In our original example, it took 105 samples to complete the display and 105 fast ramps to make 105 samples. In the second case, it takes 1,050 samples to complete the display and 1,050 fast ramps to make 1,050 samples.

A change in Equivalent Time/cm Readout on the crt can be obtained by changing the slope of the fast ramp. In the 5T3, fast ramp timing caps are switched in decade steps to provide a change in ramp slope. Thus, for a 2, 5, and 10  $\mu\text{sec}$  times a specific cap is used; for the 20, 50 and 100  $\mu\text{sec}$  times another cap is used; and so on.

To obtain the 1, 2, 5 timing sequence, we have decided to change the feedback signal to the Staircase Inverter rather than change the fast ramp slope. This method has many advantages, some of which are: (1) the charging current in the Fast Ramp circuit is constant; (2) minimum mechanical switching in the "faster" circuitry; (3) a greater number of equivalent time/cm readouts can be obtained with each ramp slope. If we return to the conditions outlined in the first example, we had an equivalent time of 1  $\mu\text{sec}$  between samples. If the equivalent time readout is changed to 5  $\mu\text{sec/cm}$ , the equivalent time between samples is 0.5  $\mu\text{sec}$ . Thus the Fast Ramp must run 0.5  $\mu\text{sec}$  longer to make each sample. For the 105th sample, the fast ramp must run 52.5  $\mu\text{sec}$ . We have not changed the size of the steps taken by the Staircase Generator, we have only changed the offset signal applied to the Comparator through the Staircase Inverter by switching a X2 divider into the feedback loop.

An equivalent Time/cm Readout of 2  $\mu\text{sec/cm}$  is obtained by switching a X5 divider into the feedback loop. By combining the X2 and X5 dividers with X10 and X100 dividers, we can obtain 9 different Equivalent Time/cm Readouts for each ramp slope. The result of this switching action is termed TIME MAGNIFICATION. We have magnified the Equivalent Time/cm Readout capabilities of each ramp slope from X1 to X500 in a 1, 2, 5 sequence. Referring again to our first example, we can go from an original time/cm readout of 10  $\mu\text{sec/cm}$  to 20 nsec/cm, with the 100  $\mu\text{sec}$  TIME POSITION RANGE (or ramp slope).

When the black knob is unlocked, it can be rotated six positions to the right before the clear plastic skirt will start to rotate. The mechanical feel of the EQUIVALENT TIME/CM control usually does not change when this happens. If we were to set the blue rectangle to the right hand edge of the 100  $\mu$ sec bracket (the blue rectangle would be immediately in front of 2  $\mu$ sec) and set the white dot six positions to the right, the Equivalent Time/cm Readout would be 20 nsec/cm. We find with the 100  $\mu$ sec ramp slope we can obtain Equivalent Time/cm Readouts from 10  $\mu$ sec/cm to 20 nsec/cm in a 1, 2, 5 sequence. At each time/cm readout the TIME POSITION control can still introduce up to 100  $\mu$ sec of delay.

When the various ramp slopes are switched into operation, we change the amount of delay that can possibly be introduced by the TIME POSITION control. In our examples so far, the maximum possible delay has been 100  $\mu$ sec. When the Equivalent Time/cm Readout was 10  $\mu$ sec, we had 10 cm or 1 screen diameter of delay. When the Equivalent Time/cm Readout was 20 nsec, with the 100  $\mu$ sec ramp slope, we had 5,000 cm or 500 screen diameters of delay. For each combination of ramp slope and Equivalent Time/cm Readout we must do the "numbers" to determine delay in terms of cms or screen diameters. When speaking of Time Position (time window or delay) with a 5T3, the actual finite time should be used; not a graticule based measure that changes every time we rotate the EQUIVALENT TIME/CM control.

We have used the term delay continuously when speaking about the TIME POSITION control. It is only logical to expect someone to ask, "Why not call it a delay control?" Well, we just happen to know the answer to that one. The delay in Time Position is the time difference between the trigger pulse and the first sample. Delay as printed on the front panel, is the relationship of the actual waveform that switched (or fired) the trigger circuit and the waveform that is displayed at the beginning of the sweep. The difference in delay between a 4S1 and a 4S2 (or 4S3) would make this time relationship difficult to define. If we added the different possible types of pretrigger signal to the other variables, the situation would approach chaos.

We stated earlier that when the TIME POSITION control is rotated from full CW to full CCW, the delay between the first trigger pulse and the first sample is increased. The TIME POSITION control can be compared to the Delay Time Multiplier in a 545A. The 5T3 is always operating in what can be described as an A DLY'D BY B mode.

There has been talk of replacing the TIME POSITION control with a calibrated 10 turn pot on a "specials" basis only. Front panel operation would further approach the 545A and for TIME DOMAIN REFLECTOMETRY applications, this would be quite handy. The only conceivable trouble is the calibrated 10 turn dial might not be large enough to cover up the FINE on the front panel. Check with Product Information for price and availability.

There is one position on the EQUIVALENT TIME/CM control that we have not mentioned. When the EQUIVALENT TIME/CM control is rotated full CCW, the 5T3 switches to Real Time Sampling operation.

## REAL TIME SAMPLING CONTROLS

There are two front panel controls which govern Real Time Sampling operation. They are the REAL TIME/CM and SAMPLING RATE controls. Real Time Sampling is switched in by rotating the EQUIVALENT TIME/CM control fully CCW.

The REAL TIME/CM control is operated and deciphered as a standard time/cm control. Sweep magnification can be selected by switching the SWEEP MAGNIFIER control on the 661 main frame. When the sweep is magnified, the dots/cm and time/cm readout will change.

The SAMPLING RATE control selects a 100 kc or 60 cps FM modulated sampling rate. In real time sampling, the rep rate of the input signal does not affect the sampling operation.

NOTES

## FRONT PANEL VAGARIES

The TD's and transistors in the Pseudo Schmitt are affected by changes in ambient temperature. If the change in ambient temperature is substantial, say greater than 5° C, the temperature change can be seen on the front panel. The TRIG LEVEL Control sets the threshold level of the Pseudo Schmitt. We know that the sweep will free run with particular setting of the TRIG LEVEL and the STABILITY controls. As the temperature varies, the combination of settings for these two controls will also vary. The "position" and width of the dead zone will also vary. A change in temperature from 25° C to 50° C will cause a change in TRIG LEVEL setting of approximately 30°.

We can approximate these conditions in the following manner. Turn on the scope in the morning (or allow at least 3 hrs of off time for cooling purposes) and set the TRIG LEVEL and STABILITY controls for a free running sweep. Switch the SLOPE from + to - and play the game as outlined in the Operators section. Note the "position" and width of the dead zone. The "position" of the dead zone will probably be 5 to 10° to the right of 0. Now let the box warm up for about 20 minutes and again play the game with the TRIG LEVEL and STABILTIY controls. The "position" of the dead zone should be within about 2° of 0 and the width should be quite narrow.

The 100 KC signal which is generated by the REAL TIME CLOCK has been seen in the Trigger circuitry. In some Phase B boxes, the 100 KC has caused jitter in the triggers. This signal is coupled to the trigger through the main frame and plug-in wiring harnesses and from the B0 in the sampling units. The 100 KC may also be coupled through the trigger switching complex at the front panel. You can look at this guy in the worst case (as far as we know) with the following set-up.

Set the 5T3 to REAL TIME at .2 msec/cm and the 661 SWEEP MAGNIFIER to X20, for a Real Time Readout of 10  $\mu$ sec/cm. Set a real time (traditional) scope for a 100  $\mu$ sec/cm sweep rate (total sweep time of 1.05 msec). Connect the real time sweep signal through a 6.8 K $\Omega$  (or 7.5 K $\Omega$ ) to a 4S1. (A 1 watt resistor won't get too hot.) Internally trigger the 5T3 with the signal DC coupled.\* Adjust the HORIZONTAL POSITION so the fall portion of the display is on screen. See Figure 1-4.

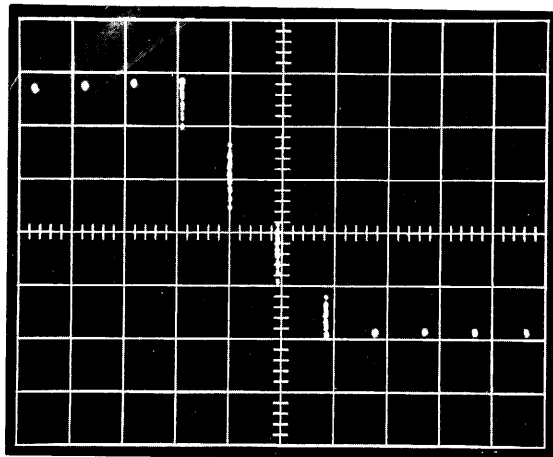

Note the 10  $\mu$ sec "glitches" on the falling portion of the waveform.

Figure 1-4

\*We tried AC coupling but lack of bandpass stopped the show.



50Ω Impedance and VSWR Information

The following VSWR data for the 50 Ω Input of the 5T3 was produced by Design Engineering. The measurements were taken from 500 MC to 8 GC. At irregular intervals, the input impedance was also calculated. The data for UHF SYNC, DC 50 Ω, and AC 50 Ω is presented in chart form. A graph of the UHF SYNC VSWR is also provided.

The graph quits before 8 GC because the graph paper had only 72 divisions, while we had 75 measurements.

Frequency	UHF SYNC		DC 50 $\Omega$		AC 50 $\Omega$	
	VSWR	Z	VSWR	Z	VSWR	Z
500 MC	1.29		2.2		2.15	
600	1.34		2.8		2.6	
700	4.2		2.8		2.75	
800	1.35	60.5-j140	3.4	65 -j75	3.3	65 -j70
900	2.8		1.42		2.4	
1.0 GC	2.5		4.8		4.2	
1.1	1.46		1.51		6.0	
1.2	1.1	50.3 -j40	6.3	40 -j92.5	7.2	35 -j97.5
1.3	1.7		14.0		20.0	
1.4	1.85		6.0		7.8	
1.5	1.8		6.8		6.1	
1.6	2.2		8.8		7.4	
1.7	3.1		10.5		10.0	
1.8	2.4		14.0		10.5	
1.9	1.8		10.0		8.8	
2.0	4.0		4.3		4.3	
2.1	6.3		4.2		4.3	
2.2	4.1	13 -j15	4.5	13 -j24	5.0	11 -j16
2.3	3.2		4.4		4.4	
2.4	4.4		5.8		6.2	
2.5	4.2		10.5		10.5	
2.6	3.6		10.5		12.0	
2.7	4.2	13 +j17	10.8	5 +j 8	13.0	4 +j 9.8
2.8	8.5		10.15		10.0	
2.9	9.5		7.2		8.5	
3.0	9.0		6.4		6.6	
3.1	8.3		4.0		4.1	
3.2	6.4	27.5 +j80	3.1	21 +j28	4.5	22 +j48
3.3	4.6		4.3		4.6	
3.4	3.2		4.3		4.8	
3.5	7.4		4.2		5.7	
3.6	15.0		3.7		4.5	

Frequency	UHF SYNC		DC 50 $\Omega$		AC 50 $\Omega$	
	VSWR	Z	VSWR	Z	VSWR	Z
3.7 GC	16.0	6.5 -j52.5	3.2	36 -j 50	6.6	14 -j 45
3.8	18.0		1.6		5.3	
3.9	9.5		2.1		2.6	
4.0	2.9		3.0		1.32	
4.1	1.42		3.0		1.3	
4.2	4.0	13 -j15	3.1	29 +j 42	1.3	50.15-j135
4.3	12.0		4.4		1.8	
4.4	10.35		8.75		5.9	
4.5	5.7		15.00		11.99	
4.6	4.3	180 +j22.5	10.0	450 -j200	8.2	400 +j110
4.7	5.0		20.0		16.0	
4.8	8.0		15.5		14.8	
4.9	1.44		7.0		6.3	
5.0	1.48		4.7		4.8	
5.1	2.6	64 -j56	6.75	42 -j110	7.0	57 -j135
5.2	6.0		10.0		13.0	
5.3	8.0		20.0		20.0	
5.4	6.25		21.0		19.0	
5.5	6.25		10.0		9.5	
5.6	7.0	9 +j32	9.0	6.5+j25.5	8.5	7 +j 23
5.7	6.75		7.75		7.1	
5.8	5.2		6.0		4.5	
5.9	2.6		4.4		4.0	
6.0	3.8		7.0		5.1	
6.1	5.8	8.5 +j11	5.5	9 +j 8	3.6	14 +j 7.5
6.2	7.3		6.25		6.0	
6.3	7.5		8.0		7.5	
6.4	8.3		8.75		8.0	
6.5	8.0		7.8		7.1	
6.6	8.4	6.5 -j17.5	7.4	7.5-j19	6.75	8 -j 19
6.7	6.0		5.75		4.8	
6.8	2.9		3.8		2.9	

Frequency	UHF SYNC		DC 50 $\Omega$			AC 50 $\Omega$	
	VSWR	Z	VSWR	Z	VSWR	Z	
6.9 GC	3.2		5.3		4.8		
7.0	6.2		6.5		6.2		
7.1	6.75	7.5 -j 9.5	6.75	7.5 -j12	6.1	8.5 -j 16	
7.2	6.75		6.5		5.2		
7.3	6.6		6.2		2.9		
7.4	7.2		5.4		3.3		
7.5	6.5		2.9		5.4		
7.6	3.8	75 +j90	1.75	90 +j10	6.2	155 -j160	
7.7	2.8		1.8		6.5		
7.8	3.0		1.4		2.6		
7.9	4.9		5.0		5.0		
8.0	5.3	20 -j52.5	6.2	18 -j55	7.75	10 -j 35	

## TRIGGER KICKOUT

In the UHF SYNC Mode, the Trigger Kickout of the 5T3 is appreciable. Calculations reveal the Trigger Kickout to be about 250 MV. If this kickout is measured with a 3S76, 4S1, or 4S2, you will obtain different voltage values. This is due to the difference in passband of the individual instruments. We measured the kickout with a 3S76 and obtained the results shown in Figures 1-5 and 1-6.

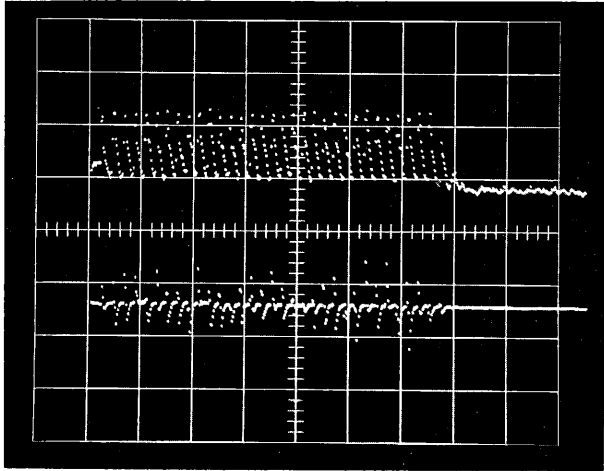

Figure 1-5

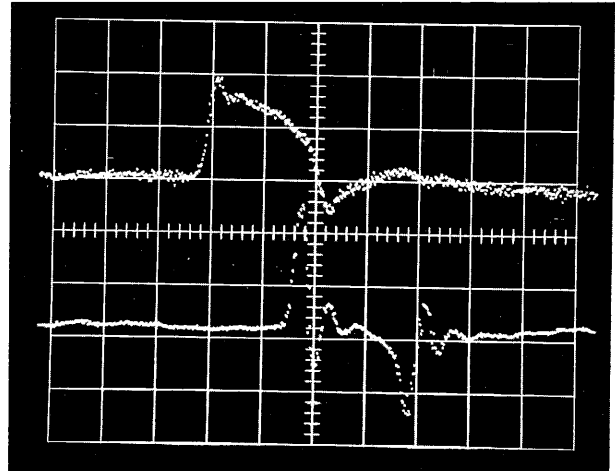

Figure 1-6

In Fig 1-5, the sweep rate is  $.1\mu\text{sec}/\text{div}$ . Channel A vertical sensitivity is 200 MV/div. and Channel B is 20 MV/div. Channel A displays the firing of the UHF SYNC Oscillator as monitored with a sampling probe and Channel B displays the kickout as monitored with a 5nsec cable at the front panel GR connector.

In Fig 1-6, the sweep rate is 2nsec/div. to display an individual oscillation and its resultant kickout. The difference in delay is probably due to different length cables and the length from the front panel to the UHF SYNC Oscillator in the 5T3.

We saw the Trigger Kickout as monitored with a 4S1. Kickout amplitude was 100 MV as compared with 80 MV on the 3S76. The Evaluation Engineer and the Design Engineer stated that normally the Trigger Kickout is 200 MV when monitored with a 4S2.

In the 50 $\Omega$  AC and DC Modes, the kickout appears as a "glitch" on a straight line display at 2 MV/div. You can just see the kickout but it is not enough to worry about.

## FRONT PANEL GOOD GUY

The 100 KC Real Time Sampling signal does allow us to play clever little games that we could never play with equivalent time sampling. When the 5T3 is in real time, an interrogate pulse is generated at the 100 KC rate. The generation of the interrogate pulse is completely independent of the input signal. If the input signal amplitude is too small for normal triggering operation, we can apply a signal from the VERT SIG OUT jack on the front panel to the High Impedance input connector on the 5T3. We can now trigger on the signal from the VERT SIG OUT jack because the vertical amplifier is "on".

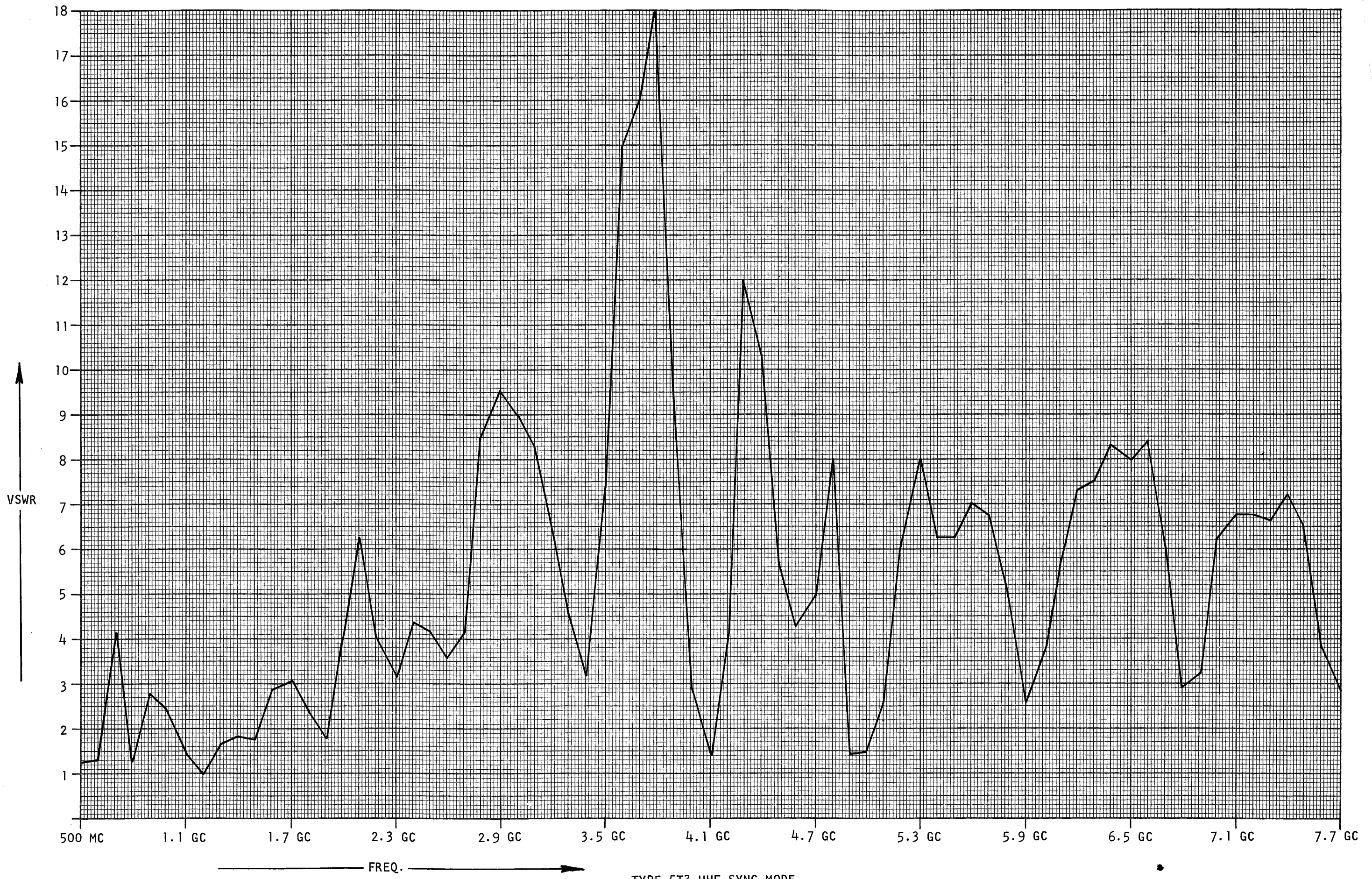

TYPE 5T3 UHF SYNC MODE

**GENERAL BLOCK DISCUSSION**



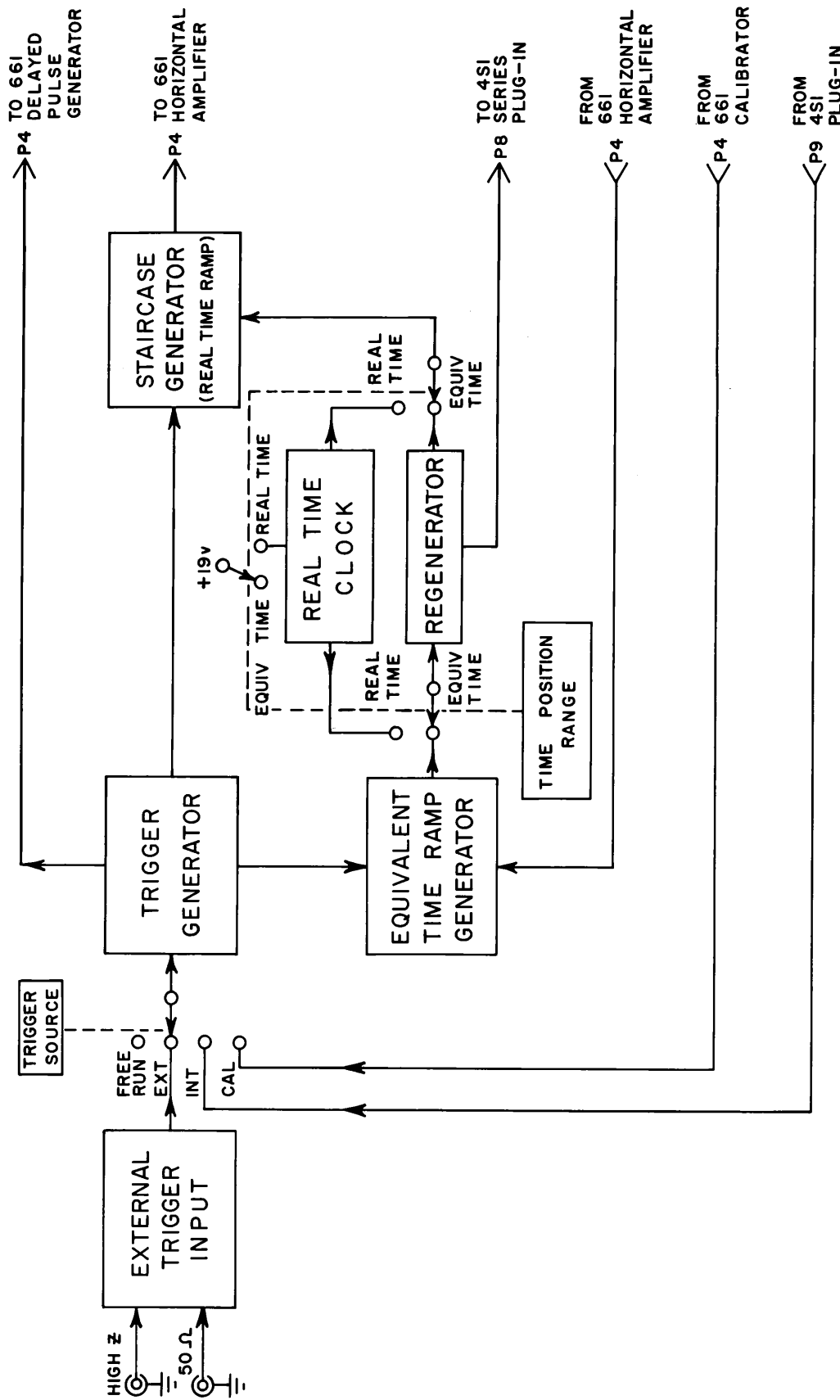

TYPE 5T3 TIMING UNIT  
BASIC BLOCK DIAGRAM



B-5T3-0001  
1-14-'65 jg

FIGURE 2-1

TYPE 5T3 BASIC BLOCK DIAGRAM

The Type 5T3 consists of an EXTERNAL TRIGGER INPUT, TRIGGER GENERATOR, EQUIVALENT TIME RAMP GENERATOR, REAL TIME CLOCK, REGENERATOR, and STAIRCASE GENERATOR. Figure 2-1 shows the basic block diagram.

The EXTERNAL TRIGGER INPUT consists of an HIGH Z INPUT, 50 $\Omega$  INPUT, EXTERNAL TRIGGER INPUT AMP, and portions of the TRIG SOURCE and SLOPE switching. In essence, the EXTERNAL TRIGGER INPUT provides methods of coupling the trigger signal to the TRIGGER GENERATOR through a 50 $\Omega$  terminated network or a HIGH Z network (1 M $\Omega$  shunted by approximately 30 pf).

The HIGH Z INPUT feeds a cathode follower whose output signal is divided by 10 before the signal is applied to the EXTERNAL TRIGGER INPUT AMP. AC or DC coupling can be selected. The high frequency 30% down point is 20 MC. In AC, the low frequency 30% down point is 160 cps (refers to sine waves only). A .001 coupling cap is used. The dynamic range is  $\pm 50$  mv to 1.5v with a maximum overload of  $\pm 100$ v.

The 50 $\Omega$  INPUT provides UHF SYNC, DC, or AC coupling. In UHF SYNC, the signal is sent directly to the TRIGGER GENERATOR. The triggering frequency range is from 500 MC to 5 GC. The low frequency 30% down point is 1 GC, but triggering can be effected with a 2 mv input signal amplitude from 1 GC to 3 GC. The usable frequency range with a 5 mv input signal amplitude goes down to 500 MC. Circuit operation is specified with a 5 mv input signal amplitude. In DC, the DC component of the signal is applied to the base of the EF input stage of the External Trigger Input Amp and the high frequency component is applied to the emitter of the Current Amp output stage through an inverter transformer. In AC, the signal is coupled through the transformer inverter to the emitter of the current amp. The dynamic range is from  $\pm 5$  to 150 mv and the maximum overload is  $\pm 5$ v. The high frequency 30% down point is 500 MC. The low frequency 30% down point in AC is 500 KC (refers to sine waves only).

The External Trigger Input Amplifier is a wide band current amplifier with a gain of unity. The low frequency signals are applied to the current amplifier through an EF. Thus the current amplifier sees the same input impedance for low frequency signals with HIGH Z or 50 $\Omega$  INPUTS.

The high frequency signals are transformer coupled to the emitter of the current amp. The output of the EXTERNAL TRIGGER INPUT is fed to the TRIG SOURCE switch.

The TRIG SOURCE switch allows FREE RUN, EXT, INT, or CAL signals to trigger the time base. The CAL signal is an AC coupled, 100 mv sine wave. AC or DC coupling for the INT signals is selected in the sampling plug-in. The triggering frequency range is DC to about 1 GC. The EXT signals are as described above. The TRIG SOURCE switch terminates the output of the External Trigger Input Amp in  $50\Omega$  when a source other than EXT is selected. FREE RUN is effected in the TRIGGER GENERATOR. The output of the TRIG SOURCE switch is applied to the SLOPE switch.

In + SLOPE operation, the triggering signal is applied directly to the emitter of the Trig Amp in the TRIGGER GENERATOR. In - SLOPE operation, the DC component of the signal is applied to the base of the Trig Amp and the high frequency component is coupled through a transformer inverter to the emitter of the Trig Amp. Coupling here is similar to the  $50\Omega$  INPUT DC mode. A similar system is also used in the Trig Amp of the 4S1. Also in - SLOPE operation, the DC voltages applied to the TRIG LEVEL control are reversed to give the right feel for operating the TRIG LEVEL.

The TRIGGER GENERATOR is the most complicated block in the 5T3. Basically there are three closed loops in the TRIGGER GENERATOR; the Pseudo Schmitt loop, the UHF SYNC loop, and the Hold-off loop. The Pseudo Schmitt loop consists of the Trigger Amplifier, Schmitt Current Source, the Pseudo Schmitt, and the Hold-Off loop. The Hold-Off loop consists of the Output T.D., the Driver (of many things), the Hold-Off Multi, and the Arming Switch. The Schmitt Current Source and the Trigger Amplifier provide a method of changing the current drive which switches the Pseudo Schmitt. When the Pseudo Schmitt fires, a signal is sent to the Output TD. The Output TD sends a signal to the Equivalent TIME RAMP GENERATOR and the Driver (of many things). The Driver starts the Hold-Off operation and turns off the Schmitt Current Source. The Driver signal also switches the Delayed Pulse Multi and tells the STAIRCASE GENERATOR to prepare to sweep.

Halfway through the hold-off interval, the complimentary Hold-Off Multi goes to its "off" state and turns off the Arming Switch. The Arming Switch returns the Output TD to its low state and the Driver is switched.

Since the Arming Switch is off, the Schmitt Current Source is still turned off. At the end of the hold-off interval, the Hold-Off Multi returns to its "on" state and turns on the Arming Switch. The Arming Switch now turns on the Schmitt Current Source and the 5T3 is ready to accept a trigger signal.

In the UHF SYNC mode, the UHF SYNC Oscillator supplies the signal that switches the Output TD and the Driver and Arming Switch controls the on and off state of the UHF SYNC Current Source. The Delayed Pulse Multi fires each time the Driver is switched by the Output TD. This multi sends a signal to the Delayed Pulse Generator in the 661 main frame.\*

In the AUTO RECOVERY mode, the Pseudo Schmitt loop is used. The difference between AUTO RECOVERY and the PSEUDO SCHMITT modes is that 1/2 of the Pseudo Schmitt is switched at the end of the hold-off interval in AUTO RECOVERY. Mechanical switching is used to select the proper current source for Pseudo Schmitt or UHF SYNC triggering.

The TRIGGER GENERATOR has three outputs. The Output TD sends a signal to start the Fast Ramp in the EQUIVALENT TIME RAMP GENERATOR. The Driver sends a signal to the STAIRCASE GENERATOR which tells it to prepare to sweep. The Delayed Pulse Multi sends a signal to the Delayed Pulse Generator which appears at the front panel about 30 nsecs later.

The operation of the remaining blocks differ in Equivalent Time and in Real Time. In Equivalent Time, the EQUIVALENT TIME RAMP GENERATOR, REGENERATOR, and STAIRCASE GENERATOR are used. In Real Time, the REAL TIME CLOCK, REGENERATOR and STAIRCASE GENERATOR are used.

The EQUIVALENT TIME RAMP GENERATOR consists of the Fast Ramp Clamp, the Fast Ramp Generator, the Comparator, and the Staircase Inverter Amplifier. The Fast Ramp Clamp is an open loop, non-saturated clamp. The Fast Ramp Clamp is turned off by the signal from the Output TD in the Trigger GENERATOR and the clamp is reset when the Output TD returns to its low state. The Fast Ramp Clamp is not reset when the Comparator fires as in the 5T1A. When the clamp is turned off, the Fast Ramp Generator runs down and supplies a sawtooth type signal to the Comparator. The Comparator sees the ramp signal

\* Check adjustment of the Delay Pulse Generator in the 661, when a 5T3 is used.

and the feedback signal from the Staircase Inverter. The feedback from the Staircase Inverter is proportional to the STAIRCASE GENERATOR output. The TIME POSITION control provides a DC bias for the Staircase Inverter Amplifier which determines how far the fast ramp will run before the Comparator fires. The output of the Comparator is sent to the REGENERATOR. When Real Time Sampling is selected, +19v is applied to the input of the Staircase Inverter Amplifier which biases the Comparator to its off state.

The REGENERATOR consists of the Main Regenerator and the Regenerator Avalanche Output. The REGENERATOR output is sent to the 4S1 series plug-in as the interrogate pulse and to the STAIRCASE GENERATOR as the step signal in Equivalent Time operation. The Main Regenerator fires each time it receives a signal from the Comparator.

The STAIRCASE GENERATOR has three major parts. They are the Staircase Start circuit, the Staircase Stepper circuit, and the Miller Sweep circuit. The Staircase Start circuit receives an input signal each time a trigger is generated. The output of the Staircase Start turns on the Reset Multi, which causes the Miller Sweep to turn on. After the Reset Multi is turned on, the Staircase Start signal has no affect on the Multi. When the Miller Sweep is turned on, it will step each time it receives a signal from the Staircase Stepper. The Staircase Stepper fires each time it is pulsed by the REGENERATOR. When the Miller Sweep has run up 10.5 cm, a feedback signal resets the Reset Multi. The Reset Multi will remain turned off by the hold-off circuitry until the Miller Sweep has reset. The Reset Multi and the Staircase Stepper send blanking signals to the Blanking Amplifier. The Reset Multi can be compared to the Sweep Gating Multi in a real time scope. The output of the STAIRCASE GENERATOR drives the Horizontal Amplifier in the 661 main frame. A portion of the signal in the Horizontal Amplifier is picked-off and fed back to the Staircase Inverter.

In Real Time Sampling, the EQUIVALENT TIME RAMP GENERATOR is turned off. The REAL TIME CLOCK sends a signal to the REGENERATOR which generates the Real Time interrogate pulse. The REAL TIME CLOCK also sends a signal to the Real Time Staircase Gate which causes the Miller Sweep to step. The Staircase Stepper is turned off in real time operation. The Staircase Start and Miller Sweep operation is the same in real and equivalent time.

The Reset Multi and the REAL TIME CLOCK send signals to the Blanking Amplifier.

The REAL TIME CLOCK consists of a Clock Master Oscillator and a Clock Output B0. The Clock Master Oscillator oscillates at a 100 KC rate. The output of the Clock Master Oscillator controls the Clock Output B0. In RANDOM sampling, the Clock Master Oscillator becomes a current source for the Clock Output B0, which is now free running. The current from the Master Oscillator varies at a 60 cps rate to FM modulate the firing of the Clock Output B0.

If a constantly running sweep was used, the type used in real time scopes, the display would be a series of slashes. Since the vertical component of the display changes each time a sample is taken, the display on the crt would slash each time the vertical component changed. By using the stepped sweep, both the vertical and horizontal components of the display change at the same time.

NOTES

## PSEUDO SCHMITT

The Pseudo Schmitt trigger circuit was developed to fulfill the need for a stable trigger circuit that would operate from DC to high frequencies. A Schmitt type trigger circuit is necessary to obtain stable displays at very low frequencies. A Schmitt type trigger will also answer the need for a trigger circuit whose front panel controls do not necessarily require readjustment as the amplitude of the trigger signal changes.

It was decided to build a TD type Schmitt circuit, because transistors would not have the speed required for high frequency switching. At first, attempts were made to build a TD Schmitt similar to that used in the Type 547, using very fast TD's. When dampening resistors were put in parallel with the TD's, they would oscillate at about 2 GC, which was not the desired result.

The problem then was to hook up a TD circuit that would switch in Schmitt fashion. We needed an arrangement in which one TD would switch on a given input slope and the second TD would switch on the opposite slope only after the first TD has switched. The basic circuit requirements became:

1. The first TD must switch only on the negative slope.
2. The second TD must switch only on the positive slope and only after the first TD has switched.
3. TD's are switched by a current drive so a method of changing the current in the TD circuit must be provided.
4. A positive current source (current demand) must be provided to force the TD's to switch in a push-pull manner.
5. Only one TD can be biased at the knee of its curve at a given time. Therefore a method of switching biasing current must be provided in the TD circuit.
6. Recovery and arming switching must be arranged to allow only one trigger pulse to be generated. The Schmitt must then be turned off until a sample is taken and the sampling circuits have reset to their quiescent state.

The circuit that was developed is shown in Figure 2-2, the Simplified Pseudo Schmitt Schematic. Before we play the game, let us identify the parts.





D157	(6.2v zener) Provides voltage reference for Pseudo Schmitt. This is the only place in the circuit that is locked at a given voltage.
D155	(10 ma TD) First TD. Also known as the trigger enabler.
D135	(10 ma TD) Second TD. Also known as the trigger recognizer.
D146/D147	(Selected GaAs diodes) Provide bias current switching.
Q149	(151-108 selected) Provides fast recovery for D135. This transistor is selected to have 0 (zero) current with an emitter-collector voltage of 100 mv and a 500 $\mu$ a base drive. When the e-c volts are greater than 100 mv, Q149 saturates.
T135/LR133	Output pulse forming network.
TRIG AMP Q124	(not shown) - Provides method of changing current drive to Pseudo Schmitt.
TRIG LEVEL	(not shown) - Threshold adjustment - part of TRIG AMP circuit.
DRIVER and ARMING SW	With the OUTPUT TD and HOLD-OFF MULTI provide recovery and arming switching for the Pseudo Schmitt.
STABILITY	Adjusts hysteresis width of Pseudo Schmitt.

The following waveforms, in Figure 2-3, were taken on a 545B-M unit combination. The 5T3 is externally triggered with a 100 mv - 10  $\mu$ sec calibrator signal. The EQUIVALENT TIME/CM control was set at .1  $\mu$ sec. The hold-off time is now set for a period of approximately 10  $\mu$ sec.

#### QUIESCENT CONDITIONS - AWAITING A TRIGGER SIGNAL

1. We are now somewhere between the end of the hold-off period and the arrival of a trigger signal. In Figure 2-3  $T_0$  is the end of the hold-off and  $T_1$  is the arrival of a trigger signal.
2. The STABILITY and TRIG LEVEL controls adjust the quiescent Schmitt current around 16.5 ma. A DC divider from +19v through R161, R160 and R158 to D157 sets the base volts of Q164. The STABILITY control sets the amount of current demanded by Q164. The TRIG LEVEL controls set the amount of current supplied to Q164 through D135. The rest of the current must be supplied by D155. We will assume a total current demand of 16.5 ma.

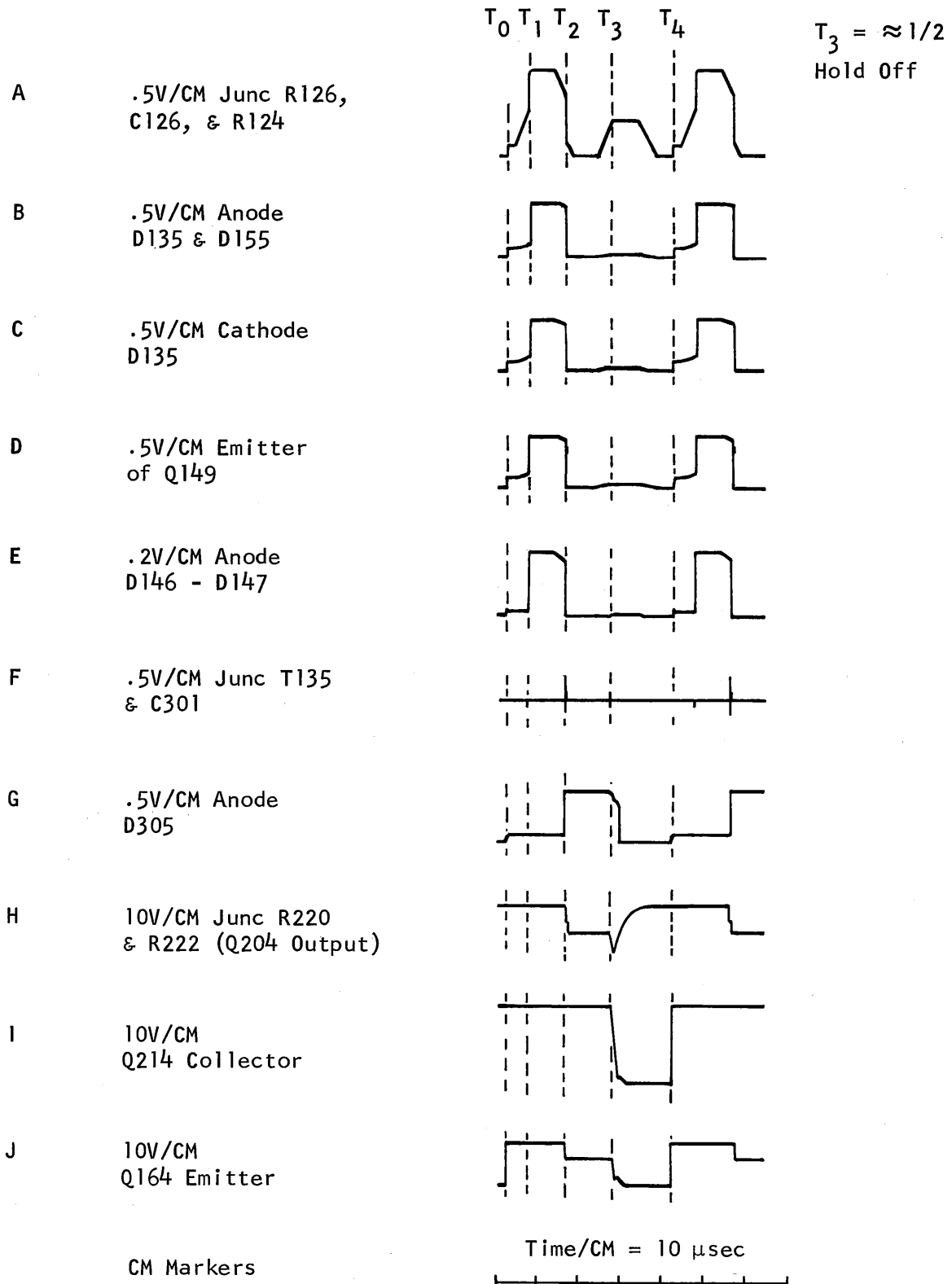

Pseudo Schmitt Waveforms  
 fig 2-3

3. Both TD's are in their low state. Circuit voltages are as follows:
  - a. Cathode of D155 - 6.2v (referenced to D157).
  - b. Anode of D155 and D135 - 6.25v (low state TD volts=50 mv).
  - c. Cathode of D135 - 6.2v.
  - d. Q149 emitter-collector volts=50 mv. Q149 is turned off.
  - e. Anode of D146 - 6.2v. No voltage drop across T135 or LR133.
4. The heaters of V583 and V13 are drawing .135A. The resultant voltage drop across the shunt combination of R149-R150 is 250 mv.
5. The anode of D147 is at 6.45v. D147 is turned on. 3.5 ma flows from -100v through R146 and through D147 to the heater string. D147 and D146 are selected to conduct 3.5 ma with 250 mv cathode-anode voltage. These have a very sharp, fast cutoff below 250 mv. D146 is off.
6. The TRIG LEVEL is adjusted for 6.5 ma through D135. D135 is biased well below the knee of its curve (switching point) and is said to be in its very low state.
7. 10 ma must flow through D155. (Current demand=16.5 ma minus D135 current= 6.5 ma.) D155 is biased close to the knee of its curve.

#### TRIGGER SIGNAL ARRIVES - FIRST PART OF SCHMITT SWITCHING SEQUENCE

1. A signal is seen at the TRIG AMP which causes D135 to conduct less. (In our case a negative going signal.)
2. As the current in D135 decreases, Q164 will demand D155 make up this current loss. When the current in D155 increases to the point where D155 switches to its high state, the trigger signal has crossed the lower hysteresis level of the Pseudo Schmitt.
3. When D155 fires:
  - a. The voltage at the anodes of D155 and D135 rises to 6.7v. (A TD in its high state drops 500 mv.) Waveform B.
  - b. The voltage at the cathode of D135 raises to 6.65v. D135 is still in its low state. Note the emitter-collector volts-of Q149 is still 50 mv and Q149 remains turned off. Waveforms C and D.
  - c. The voltage at the anode of D146 is more positive than the voltage at the anode of D147. D146 starts to conduct, raising the voltage at the cathodes of D146 and D147. Waveform E. D147 turns off and 3.5 ma flows through D146 to D135. D135 is now biased at the knee of its curve.

## SECOND PART OF SCHMITT SWITCHING SEQUENCE

1. D155 is still in its high state. The volts at the anodes of D155 and D135 can be considered to be locked solid through D155 to D157.  
(This is a secondary standard type of thing.)
2. A signal is seen at the TRIG AMP which causes D135 to conduct more.  
(In our case a positive going signal.)
3. When the current in D135 increases to the point where D135 switches to its high state, the trigger signal has crossed the upper hysteresis level of the Pseudo Schmitt. This is shown as time  $T_2$ .
4. When D135 fires:
  - a. The volts at the cathode of D135 fall to 6.15v. (The anode of D135 is locked solid.)
  - b. A magnetic field is built up around T135-LR133 and an output pulse is generated and sent to the OUTPUT TD. Waveform F.
  - c. The field will decrease at a rate controlled by LR133. As this field decreases, Q149 will conduct. Q149 will go into saturation (500  $\mu$ a base drive, +100v through a 200 KR) and rob the current from D135. If the sweep speed of the monitor scope is increased, a slight oscillation is seen on waveforms C & D as Q149 saturates.

## RECOVERY AND ARMING SEQUENCE

1. The pulse generated by T135, switches the OUTPUT TD. Waveform G. When the OUTPUT TD fires, the DRIVER is turned on. The DRIVER decreases the current demand of Q164 and returns D135 and D155 to their low state. D146 turns off and D147 turns on.
2. Hold-off action is also initiated by the DRIVER. Halfway through the hold-off period, the ARMING SW is turned off.
  - a. The ARMING SW completely shuts off the current demand of Q164 and resets the OUTPUT TD.
  - b. When the output TD is reset, the DRIVER is turned off, but the ARMING SW keeps the Pseudo Schmitt turned off.
3. At the end of the hold-off period, the ARMING SW is turned on. The conditions outlined in the Quiescent Conditions are again present. This is shown as  $T_4$ . Note  $T_4$  and  $T_0$  refer to the same thing.

The TD's are connected in parallel and fire in a push-pull sequence.

The circuit is not a true Schmitt, but the results are what we would

expect with a Schmitt circuit. Thus the name Pseudo Schmitt.

Figure 2-4 shows the effects of the STABILITY and TRIG LEVEL controls on the Pseudo Schmitt. These pictures were taken at the junction R126, C126, and R124. This particular junction is the best place to see the Schmitt switching superimposed on the input signal.

Waveform A shows the hysteresis width as the STABILITY control is set CW to the ragged edge of triggering. Waveform B shows the hysteresis width as the STABILITY control is set CCW to the ragged edge of triggering. The second TD, D135 (the trigger recognizer) switches at the same place on the input signal each time. The first TD, D155 (the trigger enabler) switches at different places on the input signal as the STABILITY control is rotated.

Waveform C shows the trigger threshold as the TRIG LEVEL control is set CW to the ragged edge of triggering. Waveform D shows the trigger threshold as the TRIG LEVEL control is set CCW to the ragged edge of triggering. When the TRIG LEVEL control is rotated, the firing point of both TD's will change.

D146 and D147 are a matched pair and will have a special part number. Q149 is also a selected transistor but it will not have a special part number. About 90% of the 151-108's will work in this circuit. To avoid pick and choose games, the potential replacement part should be tested on a curve tracer. The Type 575 should be set up for a 500  $\mu$ a base drive. Check for 0 (zero) collector current with 100 mv applied from emitter to collector and then check for saturation as the applied voltage is increased above 100 mv. D135 is also selected and will have a special part number.

Normally the Pseudo Schmitt is protected from overloads by EXT TRIG AMP. Either resistors or transistors will blow before the Schmitt is harmed. If for some reasons the Schmitt gives up, D155 should be checked first. A chain of events type thing, could cause D155 to go, then D135, and then either Q164 or the TRIG AMP, Q124. The primary function of R126-C126 is to provide protection for the Pseudo Schmitt.

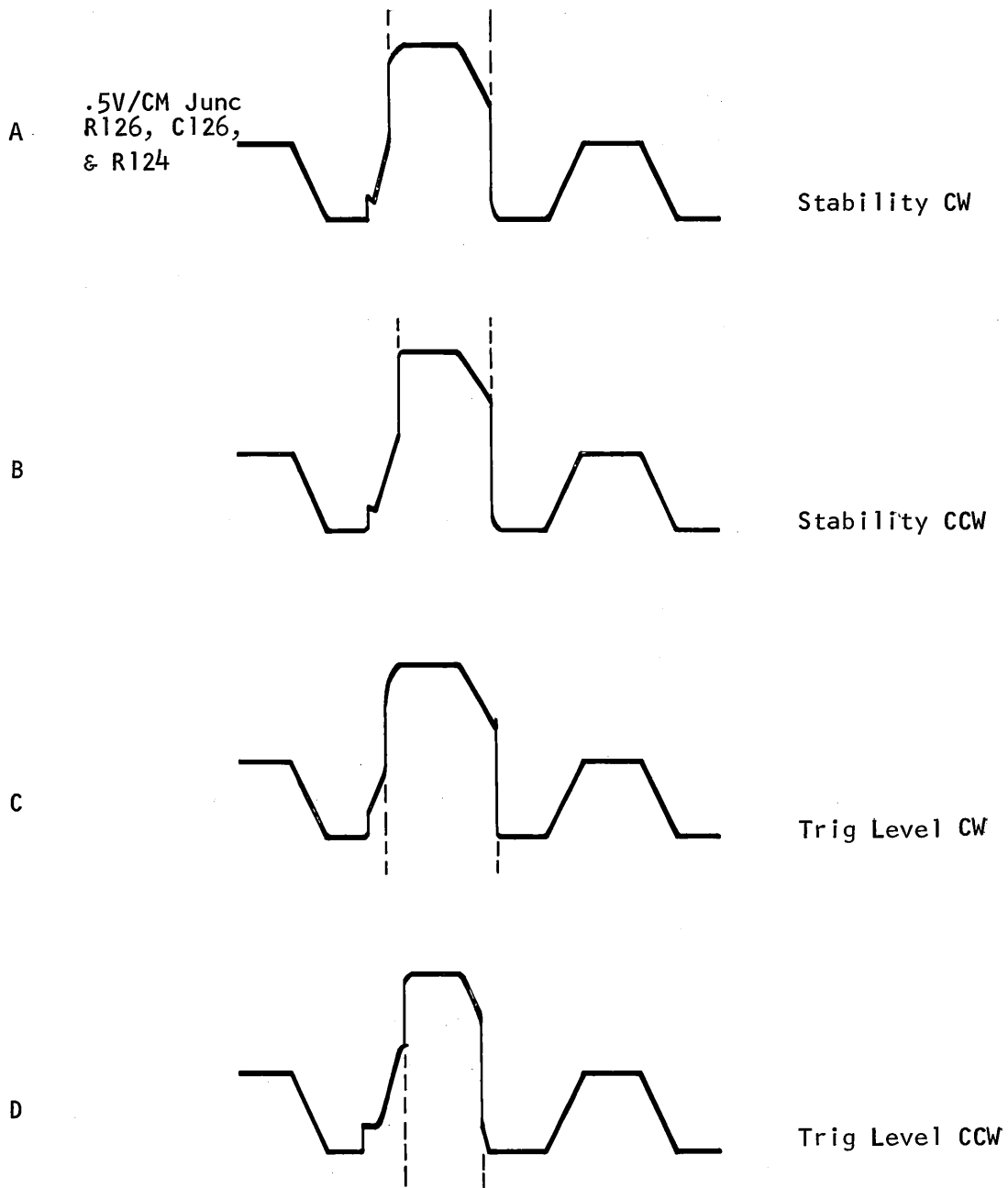

Time/CM = 10  $\mu$ sec

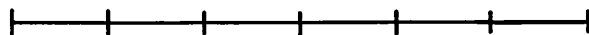

fig 2-4

5T3 TRAINING CALIBRATION PROCEDURE  
(Short Form)

The following calibration procedure is a short form version covering only the adjustments using minimum amount of test equipment. For a complete calibration, refer to the Long Form Calibration Procedure. The Long Form Training Calibration Procedure insures that the 5T3 meets or exceeds all advertised performance requirements.

Equipment Required:

1. 2 nSEC GR cable.
2. Pocket piper (1 mSEC time markers) approximately 300 to 1K $\Omega$  resistors required to prevent loading piper.
3. Handy dandy little screwdriver.
4. Voltmeter 20,000 $\Omega$ /v.
5. 50 $\Omega$  GR Atten.
6. Coil "tweaker" (for adjusting 100 kc oscillator).



## OUTLINE OF ADJUSTMENTS

	<u>Page No.</u>
I TRIGGER INPUT DC Adjustments	2-22
A. 50 $\Omega$ DC LEVEL ZERO Adj. (R83)	2-22
Adjust for zero volts at J80.	
B. 1 MEG LEVEL ZERO Adj. (R10)	2-22
Adjust for zero volts at J80.	
II. TRIGGER Adjustments	2-23
A. DC LEVEL ZERO (R103)	2-23
Adjust for zero volts at emitter of Q124.	
B. OUTPUT TD BIAS Adj. (R210)	2-24
Adjust just short of free running.	
C. TRIG LEVEL ZERO Adj. (R120)	2-24
Adjust for proper operation of TRIG LEVEL control.	
D. STABILITY ZERO Adj. (R172)	2-27
Adjust until 5T3 free runs with slight CW rotation of STABILITY control.	
III. SWEEP DC Adj. - REAL TIME Adj.	2-28
A. STAIRCASE ZERO Adjustment (R585)	2-28
Adjust for zero volts at the output of the HORIZONTAL Sweep Generator.	
B. SWEEP LENGTH Adj. (R612)	2-29
Adjust for 10.5 cm of sweep.	
C. REAL TIME SWEEP CAL (R515)	2-30
Timing spec. $\pm 3\%$ .	
D. 100 KC Clock Adj. (L625)	2-31
Adjust oscillator to 100 kc $\pm 1\%$ .	

	<u>Page No.</u>
IV. FAST RAMP - INVERTER Adjustment	2-34
A. INVERTER DC LEVEL Adj. (R376)	2-34
Adjust for zero volts at input to Inverter Amp.	
B. TIMING CURRENT Adj. (R340)	2-36
Equivalent Timing Accuracy ±3%.	
C. COMP LEVEL (R345)-TIME POSITION ZERO Adj. (R390)	2-37
Adjust for minimum separation and distortion of start of sweep.	
D. 1 nSEC TIMING Adj. (C343)	2-40
Tol. ±3%.	
E. 10 nSEC TIMING Adj. (C350H)	2-41
Tol. ±3%.	
V. DOTS/CM Adjustment	2-42
A. DOTS CAL (R415)	2-42
Adjust for correct DOTS/CM SAMPLES/CM set to 5.	
B. 10, 20, 50, 100 DOTS Adj.	2-43
Adjust for correct DOTS/CM.	
10 Dots - C560G	
20 Dots - C560E	
50 Dots - C560C	
100 Dots - C560A	

Preset the following front panel controls.

5T3

SAMPLES/CM	100
TIME POSITION	Midrange
EQUIVALENT TIME/CM	10 nSEC
MAGNIFIER	X1
TRIG LEVEL	CCW
STABILITY	CCW
TRIG SOURCE	CAL
SLOPE	+
EXT TRIG MODE	50 $\Omega$ DC
REAL TIME/CM	1 mSEC
SAMPLING RATE	100 kc
SWEEP MODE	NORM

4S1

MODE	A Only
TRIGGERING	A
COUPLING	DC
CH 1 - CH 2	
VERT. POSITION	midrange
MILLIVOLTS/CM	200
VARIABLE	CALIBRATED
DC OFFSET	midrange
DISPLAY	NORMAL
SMOOTHING	NORMAL

661

HORIZONTAL DISPLAY	X1
AMPLITUDE/TIME CALIBRATOR	
MV AMPLITUDE	1000
$\mu$ SEC/cycle	OFF
FOCUS	} midrange
INTENSITY	
ASTIGMATISM	

Figure 1 illustrates the preset positions.

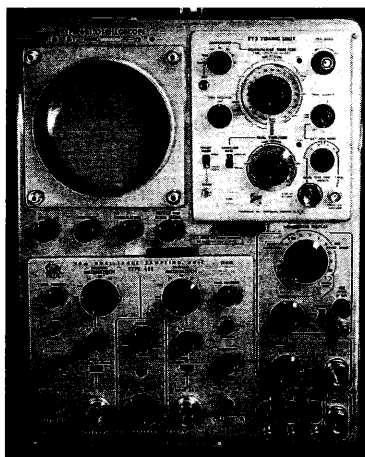

Figure 1

## I. TRIGGER INPUT DC Adjustments

A.  $50\Omega$  DC LEVEL ZERO Adj. (R83)

1. Insert a GR  $50\Omega$  terminator (or Atten) into the  $50\Omega$  EXT. TRIG INPUT connector.
2. Connect a voltmeter to the junction of C65-R80 (J80 connector), see figure 2.

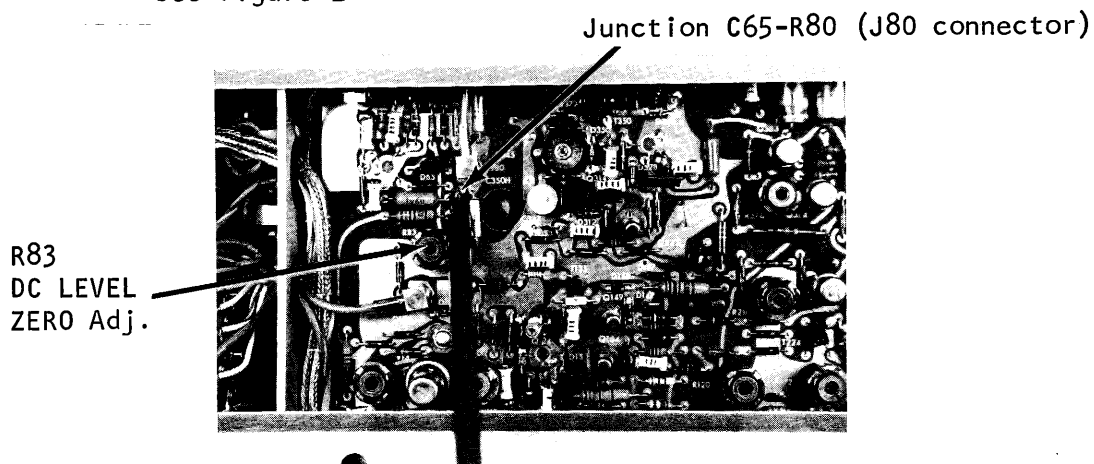

Figure 2

3. Adjust  $50\Omega$  DC LEVEL ZERO (R83 - see figure 2) for zero volts as read on the voltmeter.

## B. 1 MEG LEVEL ZERO Adj. (R10)

1. Set the EXT TRIG MODE control to the 1 MEG - DC position.
2. A  $50\Omega$  termination should be used on the 1 M $\Omega$  input connector (optional).
3. With the voltmeter connected to the junction of R80-C65, adjust 1 MEG LEVEL ZERO (R10 - see figure 3) for zero volts.

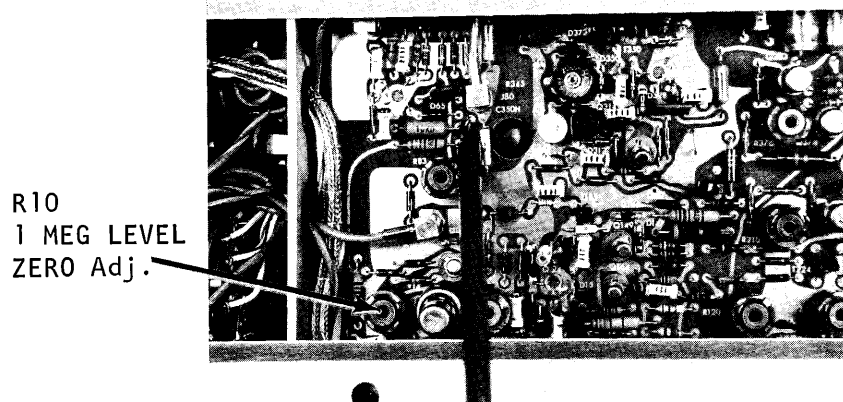

Figure 3

4. Disconnect the voltmeter and  $50\Omega$  Attenuator.

## II. TRIGGER Adjustments

### A. DC LEVEL ZERO (R103)

1. Preset the TRIG LEVEL control to midrange (centered) and STABILITY to CCW position.
2. Preset TRIG LEVEL ZERO Adj. (R120 - see figure 4) fully CCW position

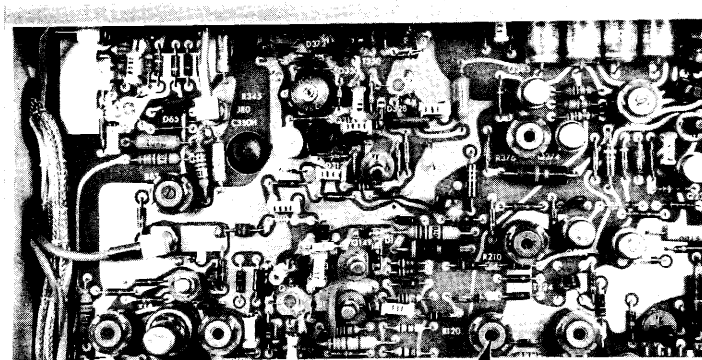

R120  
TRIG LEVEL ZERO

Figure 4

3. With the voltmeter, set the emitter of Q124 to zero (0) volts by adjusting DC LEVEL ZERO Adj. (R103 - see figure 5).

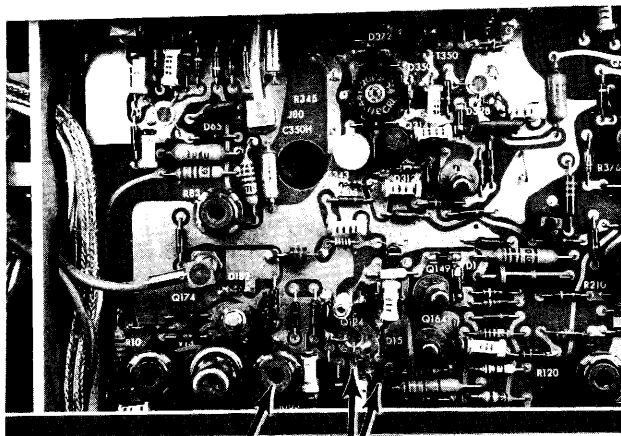

R103  
DC LEVEL ZERO ADJ.      EMITTER Q124

Figure 5

4. Disconnect the voltmeter.

**B. OUTPUT TD BIAS Adjustment (R210)**

1. Preset front panel TRIG LEVEL and STABILITY to fully CCW position.
2. Preset STABILITY ZERO Adj. (R172 - see figure 6) full CCW and preset OUTPUT TD BIAS Adj. full CW (free running).

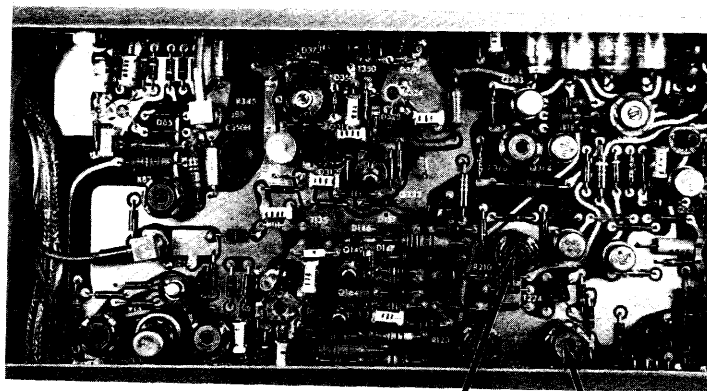

R210  
Preset CW

R172  
Preset CCW

Figure 6

3. Adjust the OUTPUT TD BIAS Adj., CCW (R210) to a point just short of free running (trace disappears from 661 CRT) plus another couple degrees additional rotation.
- C. TRIG LEVEL ZERO Adjustment (R120)**
1. Preset STABILITY zero Adj. (R172 - see figure 6) full clock-wise and then back off approximately 30°.
  2. Set the STABILITY control (front panel) full CW to the AUTO RECOVERY position (switch position).
  3. Set the TRIG LEVEL control to center or midrange (12 o'clock).

- Adjust the TRIG LEVEL ZERO Adj. (R120 - see figure 7) until a slight (few degrees) rotation of the front panel TRIG LEVEL control away from center toward CCW (minus) position will cause a free running trace on the 661 CRT.

Sweep should free run with slight CCW rotation of TRIG LEVEL control.



STABILITY set to AUTO RECOVERY.

Slope to +

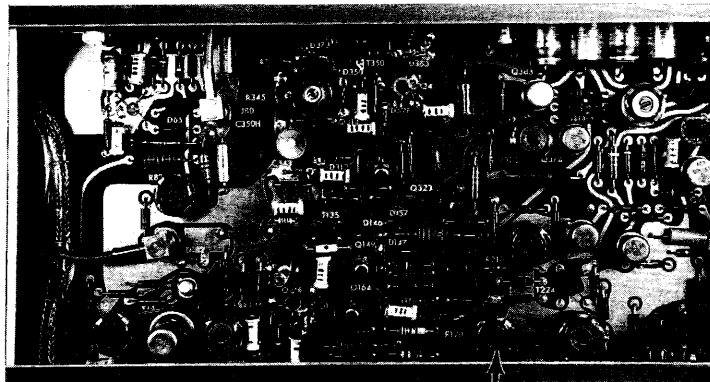

R120  
TRIG LEVEL ZERO Adj.

Figure 7



5. Set the SLOPE switch to - (minus) position.
6. A slight rotation of the TRIG LEVEL control away from center toward CW (plus) position should cause the 5T3 to free run. Slight adjustment of TRIG LEVEL ZERO may be required.

#### SUMMARY

7. By setting the SLOPE switch from + to -, turn the TRIG LEVEL control a small amount away from center toward minus (SLOPE in +) or plus (SLOPE in -) will cause the 5T3 to free run. Readjust TRIG LEVEL ZERO for the smallest amount of dead zone about mechanical center (see figure 8). (The TRIG LEVEL control knob may have to be relocated in case the dead zone does not fall near mechanical center.)

NOTE: The adjustment of R120 to obtain a dead zone near the center of TRIG LEVEL control is desired. There is just one problem, this zone will vary about  $\pm 30\%$  from the 12 o'clock position as the ambient temperature varies  $\pm 25^\circ\text{C}$ . This movement of the dead zone is normal and should not cause unstable triggering.



Figure 8

D. STABILITY ZERO Adjustment (R172)

1. Set the SLOPE switch to the + (plus) position.
2. Set the TRIG LEVEL control to the free run position (slight rotation CCW from center). Do NOT readjust the TRIG LEVEL control for the remainder of this adjustment.
3. Set the STABILITY control to 12 o'clock position.
4. Adjust the STABILITY ZERO Adj. (R172 - see figure 9) until the 5T3 free runs (trace on 661 CRT) with a slight CW rotation of the STABILITY control and stops free running with a slight CCW rotation of the STABILITY control.

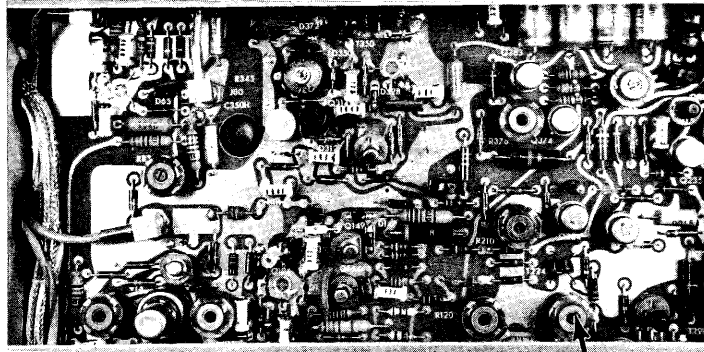

R172  
STABILITY ZERO Adj.

TRIG LEVEL  
to free run position  
CCW from center

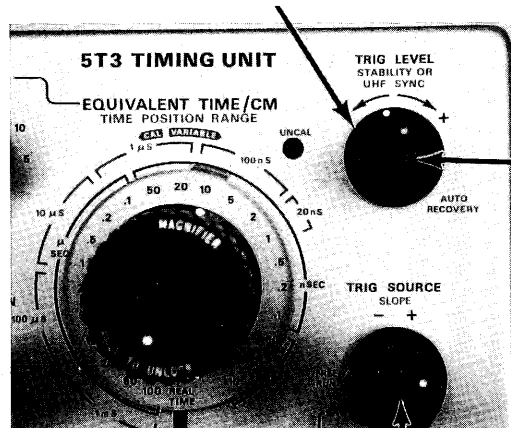

STABILITY  
to 12 o'clock.

SLOPE +

Figure 9

### III. SWEEP DC Adj. - REAL TIME Adjustments

Preset the following front panel controls.

EQUIVALENT TIME/CM	2 $\mu$ SEC/CM
REAL TIME/CM	1 mSEC
TRIG SOURCE	FREE RUN
SWEEP MODE	SINGLE DISPLAY

#### A. STAIRCASE ZERO Adjustment (R585)

1. If a test scope and X1 probe is available it should be used for setting the output of the Horizontal Sweep Generator to zero volts. A multimeter will be adequate if a test scope is not available.
2. Connect the multimeter (+) to the output of the sweep generator (one end of the EQUIVALENT TIME/CM VARIABLE control (R650), see figure 10.

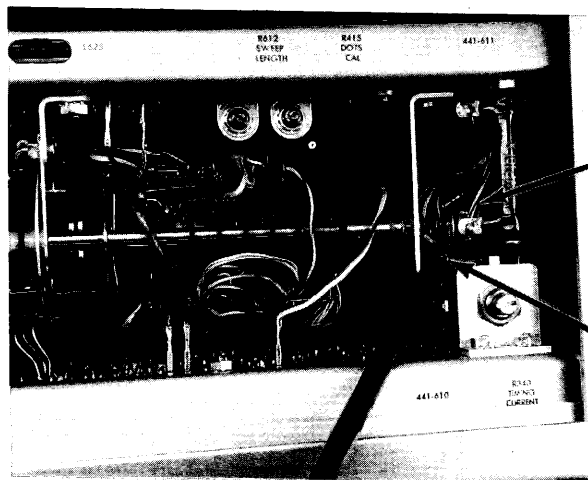

Figure 10

3. Adjust STAIRCASE ZERO Adj. (R585 - see figure 11) for approximately +25 millivolts. (There is a signal present at the test point. Optimum adjustment is to set the bottom of the waveform at zero volts. The voltmeter will read the average voltage. Therefore, when using the voltmeter, set for a slight positive voltage  $\approx 25$  mvolts.)

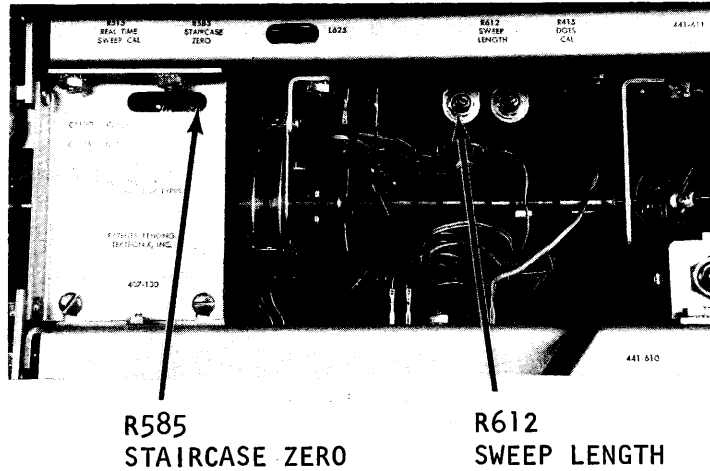

Figure 11

4. Disconnect the multimeter.
- B. SWEEP LENGTH Adjustment (R612)
1. Set the SWEEP MODE control to NORM.
  2. Adjust the SWEEP LENGTH Adj. (R612 - refer to figure 11) for 10.5 cm of sweep on the 661 CRT screen.

C. REAL TIME SWEEP CAL Adjustment (R515)

1. Set the EQUIVALENT TIME/CM control to REAL TIME position (REAL TIME/CM should be setting at 1 msec).
2. Apply from the pocket piper, 1 msec markers to the input of the 4S1.

Note: The pocket piper we were using could not be connected directly into the  $50\Omega$  input of the 4S1 without loading the output of the piper. By experimenting, we found that approximately  $300\Omega$  or higher resistance inserted between the piper and 4S1 input was adequate to prevent overloading.

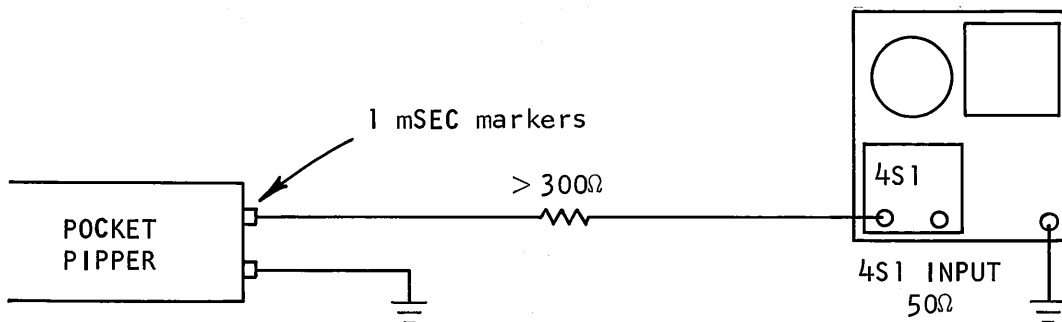

With the above arrangement, a very small signal was available at the input of the 4S1. By setting the MILLIVOLTS/CM to 10 or 5 and using the SMOOTHING control, a usable display was obtained (figure 12). Reset SMOOTHING control back to NORMAL after adjusting timing.

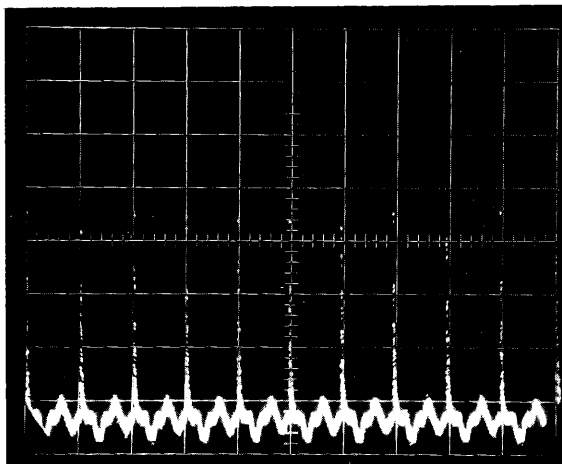

Figure 12

3. Set the 5T3 TRIG SOURCE control to INT and adjust TRIG LEVEL and STABILITY control for a stable display.
4. Adjust REAL TIME SWEEP CAL (R515 - see figure 13) for 1 (one) time marker/cm ( $\pm 3\%$ ).

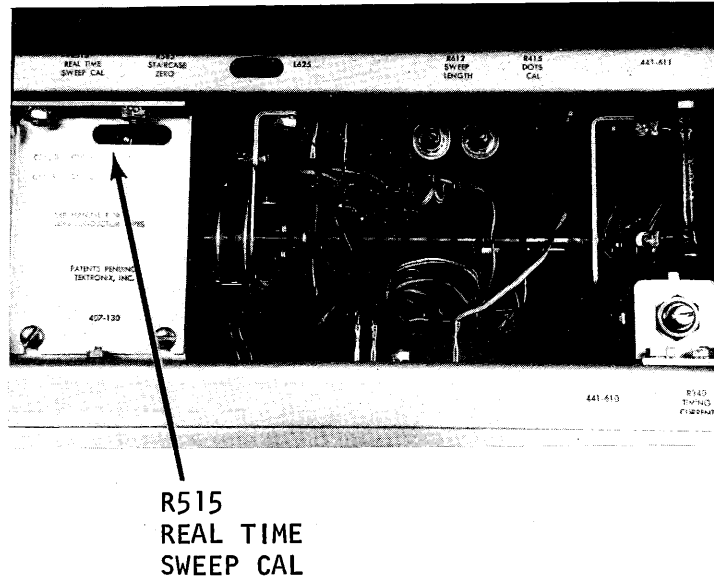

Figure 13

5. Disconnect the pocket piper. Reset MILLIVOLTS/CM control back to 200.
- D. 100 kc Clock Adjustment (L625)
- The 100 kc oscillator is adjusted for 100 kc (10  $\mu$ sec)  $\pm 1\%$ . The accuracy of the 100 kc clock is not critical if the signals from the 5T3 instrument are not used with a digital system (example - 6RIA). Therefore, this step could be omitted if the REAL TIME system is operating properly.
1. Connect a GR cable from the 661 CALIBRATOR output to the 4S1 input.
  2. Set the EQUIVALENT TIME/CM to 10  $\mu$ sec and the 661 TIME CALIBRATOR to 10  $\mu$ SEC/CYCLE.

3. Adjust 5T3 triggering controls for a stable display (figure 14).

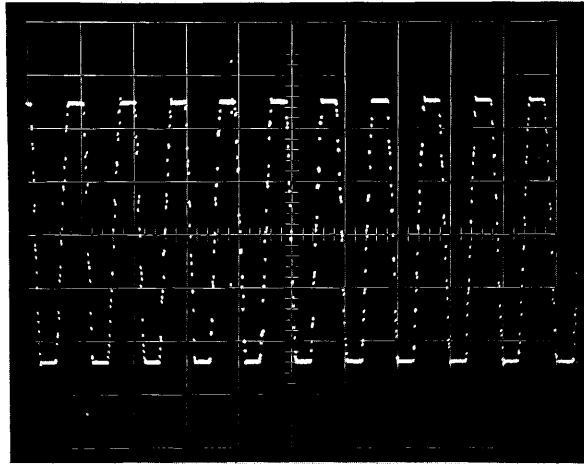
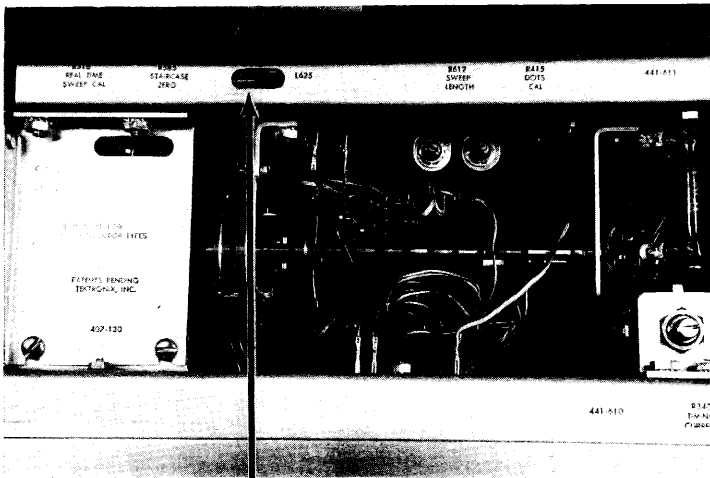

Figure 14

4. Reset the EQUIVALENT TIME/CM to REAL TIME and the REAL TIME/CM to .2 msec. Recheck SAMPLING RATE switch to be sure it is setting at 100 kc.
5. The display on the 661 CRT will be the beat frequency between the 10  $\mu$ sec calibrator and the 100 kc oscillator in the 5T3.

Note: The 5T3 100 kc oscillator is adjusted to 100 kc  $\pm 1\%$ . A 1% specification indicates a beat frequency of 1 kc (1 msec). Therefore, the time between pulses displayed on the CRT should be 1 msec or greater. It is not difficult to obtain a beat frequency of .1 sec or even 1 sec.

6. Adjust L625 for a "straight" line on the crt  
 See Figure 15A. The beat frequency can be measured by setting the REAL TIME/CM control to a slower sweep rate and measuring the time between pulses  
 See Figure 15B



L625 (A)

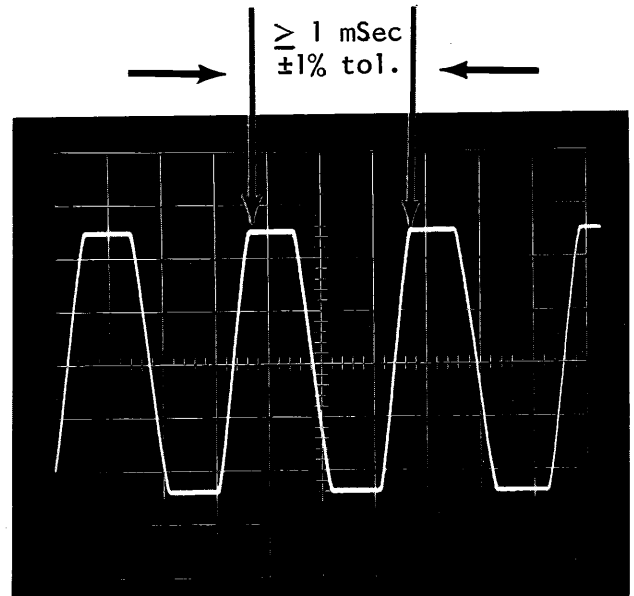

(B)

FIGURE 15

7. Leave 661 calibrator connected for the next steps



#### IV. Fast Ramp-Inverter Adjustments

##### A. INVERTER DC LEVEL Adjustment (R376)

1. Preset the following front panel controls
 

EQUIVALENT TIME/CM	20nSEC
TRIG SOURCE	FREE RUN
SWEEP MODE	SINGLE DISPLAY
TIME POSITION (Black Knob)	FULL CW
TIME POSITION-Fine (Red)	FULL CW
  
2. Because there is a small negative signal present at input of the Inverter Amplifier, an oscilloscope and X1 probe is recommended. A voltmeter can be used and will read the average of the signal. Optimum adjustment is to set the top of the waveform to zero volts. When using a voltmeter, set for a slight negative voltage, approx. 20 millivolts.
  
3. Connect the voltmeter to the input of the Inverter Amplifier. (Junction of R381, R383 and R385). The easiest place to connect the probe is terminal H of the fast ramp circuit board. Figure 16

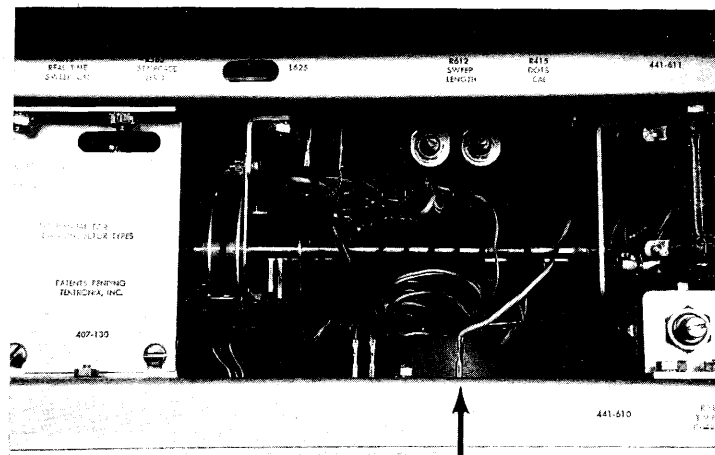

Input to Inverter Amp.  
Pin H.

FIGURE 16

4. Adjust INVERTER DC LEVEL Adj. (R376 - See Figure 17)

For approx. - 20 millivolts as measured with a voltmeter.

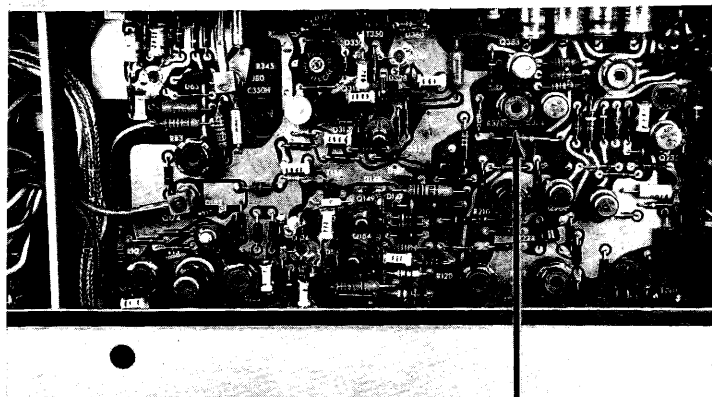

FIGURE 17

R376  
INVERTER DC LEVEL Adj.

5. Disconnect the voltmeter and reset sweep MODE to NORMAL.

## B. TIMING CURRENT Adjustment

1. Reset EQUIVALENT TIME/CM control to  $1\mu\text{sec}$
2. Apply from the 661 Calibrator,  $1\mu\text{SEC}/\text{CYCLE}$  signal. Adjust triggering controls for a stable display. (If you are unable to obtain a display on the 661 crt, the COMP LEVEL internal adjustment (R345) may be misadjusted. The COMP LEVEL should be set as far CW as possible and still obtain a stable display).
3. Preset the TIME POSITION controls (Black Knob) to mid range.
4. Adjust TIMING CURRENT control (R340 - See Figure 18) for one cycle/cm.

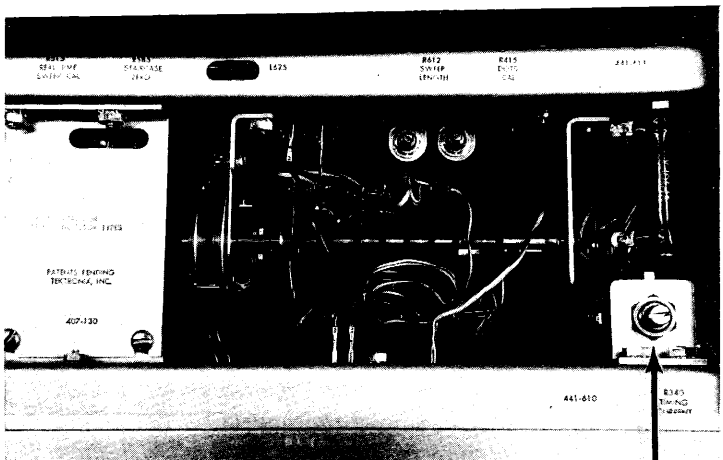

R340  
TIMING  
CURRENT

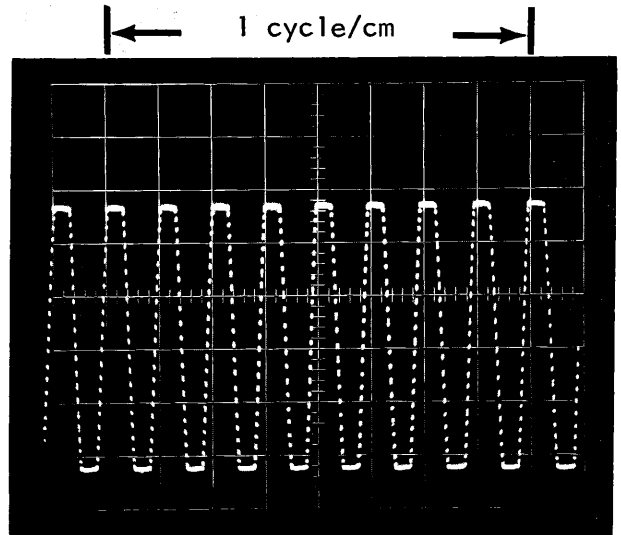

FIGURE 18

C. COMP LEVEL-TIME POSITION ZERO Adjustment

1. Set the EQUIVALENT TIME/CM to  $2\mu\text{SEC}$  and the SAMPLES/CM to 50.
2. Set the 661 Calibrator to  $10\mu\text{SEC}/\text{CYCLE}$  position.
3. Reset the TIME POSITIONS (Black and Red Knobs) full clockwise.  
It is very important that both controls are set to full CW position.
4. Adjust the TRIG LEVEL and STABILITY controls for a stable display  
Figure 19

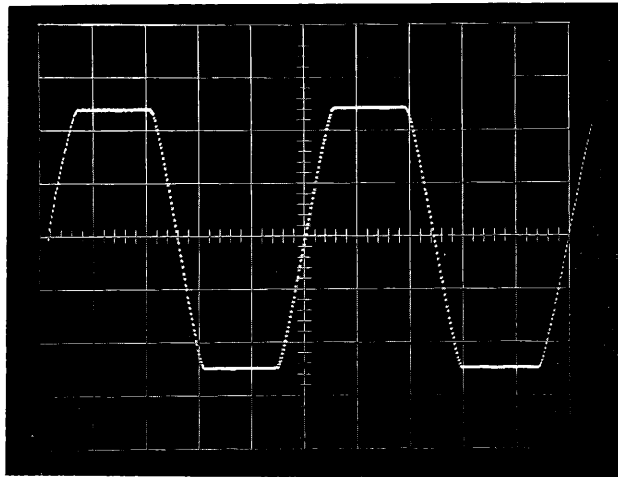
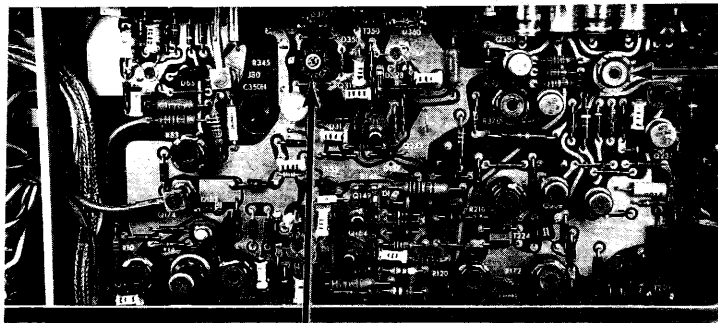

FIGURE 19

5. Preset TIME POSITION ZERO adj. (R390 - See Figure 20) full CCW.
6. Adjust COMP LEVEL adj (R345 - See Figure 20A) for minimum time separation between the flat baseline and the start of the wave (Figure 20B) (the correct adjustment sets R345 near the clockwise end of the range that will allow the sweep to free run. If the control is tuned too far clockwise, the waveform will disappear.)



R390  
TIME POSITION  
ZERO, Preset CCW.

(A) R345 COMP LEVEL

adjust  
for  
minimum  
separation

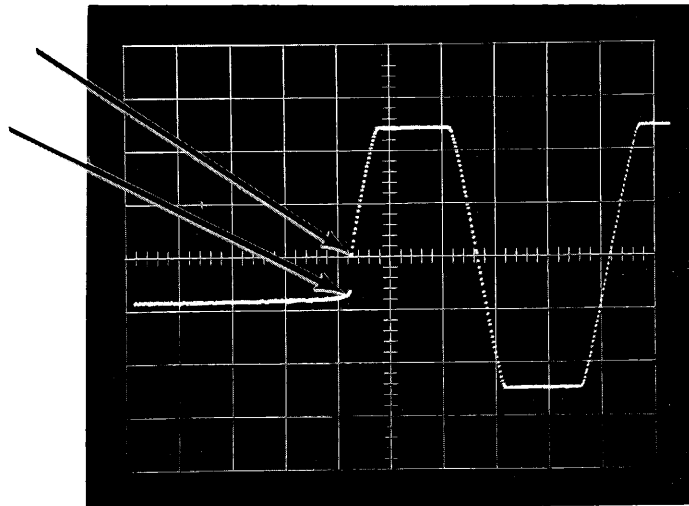

(B)

FIGURE 20

7. Adjust TIME POSITION ZERO (R390 - See Figure 21A) for least distortion at start of sweep. Figure 21B.

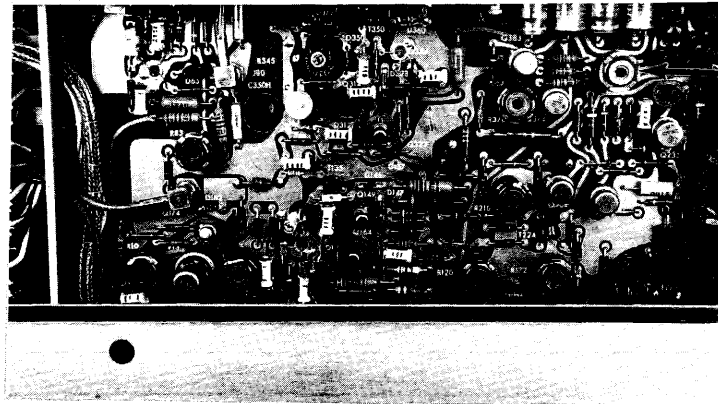

R390  
TIME POSITION  
ZERO

(A)

misadjusted

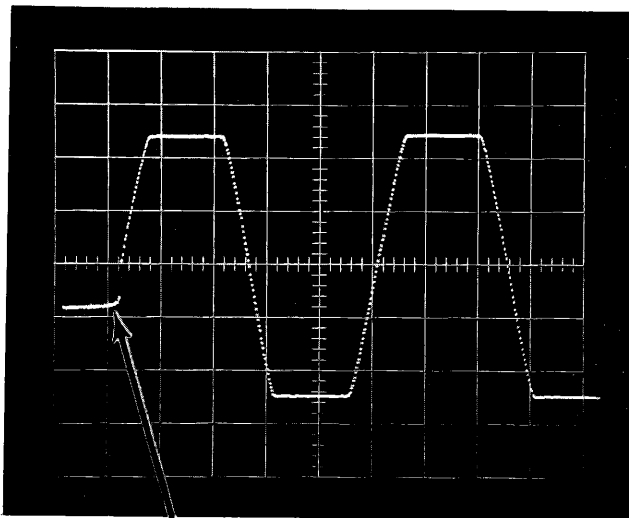

correct adjustment

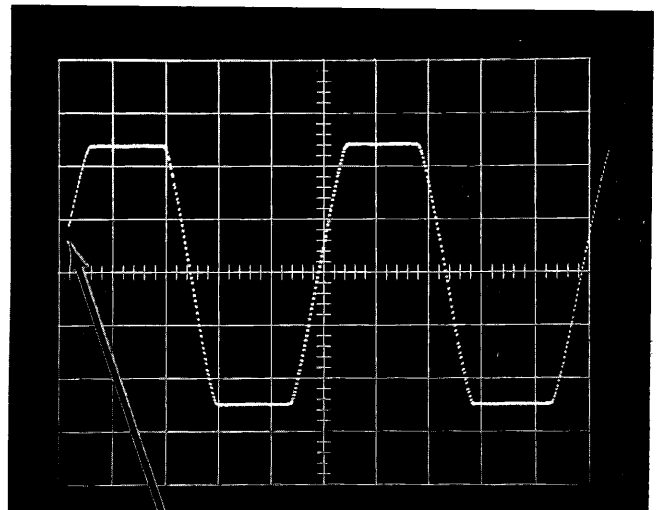

Adjust for minimum distortion at start of sweep

FIGURE 21

D. 1 nSEC TIMING adjustment.

1. Set the EQUIVALENT TIME/CM to 1 nSEC position.
2. With .01  $\mu$ SEC/CYCLE Calabrator signal displayed, adjust C343 (1 nSEC/CM) for 1 cycle over the 10 CM. Figure 22.

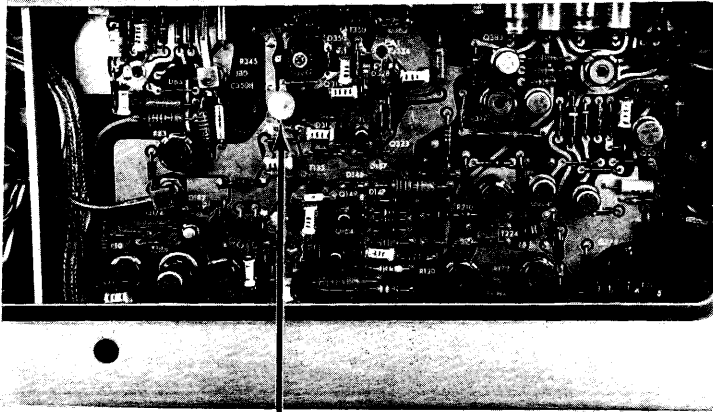

C343  
1 nSEC/CM adj.

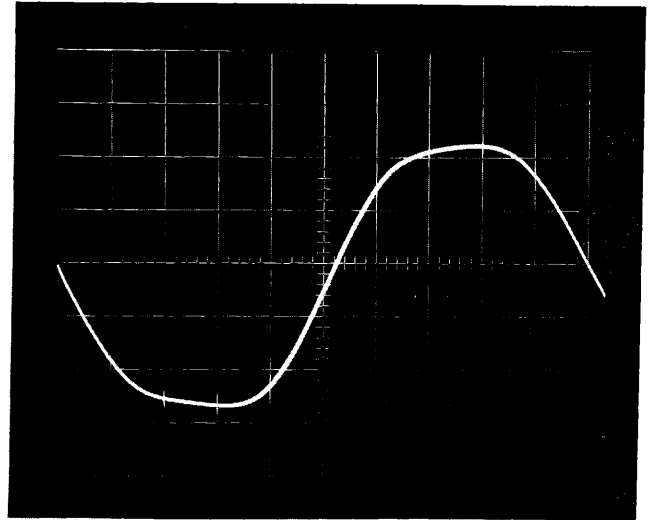
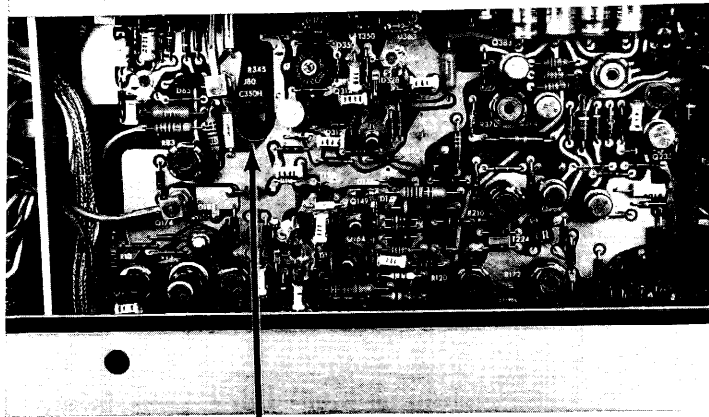

FIGURE 22

E. 10 nSEC TIMING adjustment

1. Set the EQUIVALENT TIME/CM to 10 nSEC.
2. Set the 661 calibrator to .01  $\mu$ SEC/CYCLE position.
3. Reset TIME POSITION controls to midrange and adjust triggering controls for a stable display.
4. Adjust 10 nSEC TIMING capacitor (C350H) (Figure 23) for 1 CYCLE/CM.



C350H  
10 nSEC TIMING adj.

FIGURE 23

5. Disconnect the 661 calibrator signal.



## V DOTS/CM Adjustment

### A. DOTS CAL (R415)

1. Preset the following front panel controls

#### 5T3

EQUIVALENT TIME/CM	20 nSEC
TIME POSITION	Midrange
SAMPLES/CM	5
TRIG SOURCE	FREE RUN
SWEEP MODE	NORM

#### 661

HORIZONTAL DISPLAY	X5
--------------------	----

2. For this adjustment the gain of the 661 Horizontal Amplifier should have been calibrated.
3. Adjust DOTS CAL (R415 - See Figure 24) for one dot/cm.

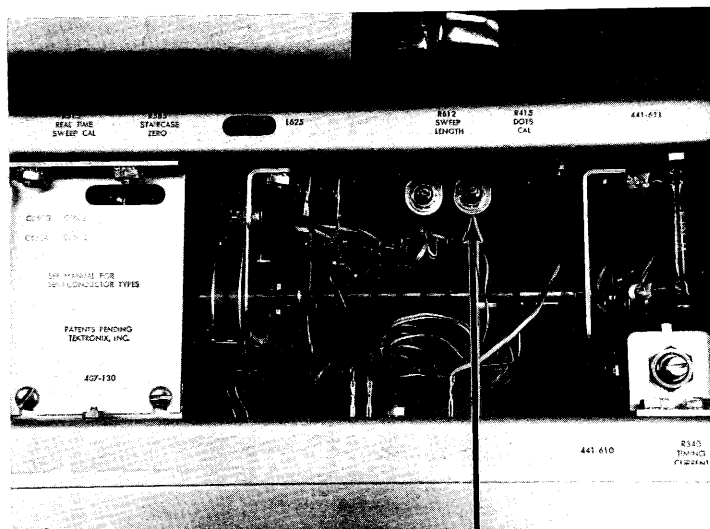

R415  
DOTS CAL.

FIGURE 24

B. 10, 20, 50, 100 DOTS CAL

- Using the following table adjust each position of the SAMPLES/CM Switch (10 - 100 DOTS/CM)

<u>SAMPLES/CM</u>	<u>661 HORIZ DISPLAY</u>	<u>ADJUST DOTS ADJ</u>	Figure 25
10	X 10	C560G	
20	X 20	C560E	
50	X 50	C560C	
100	X100	C560A	

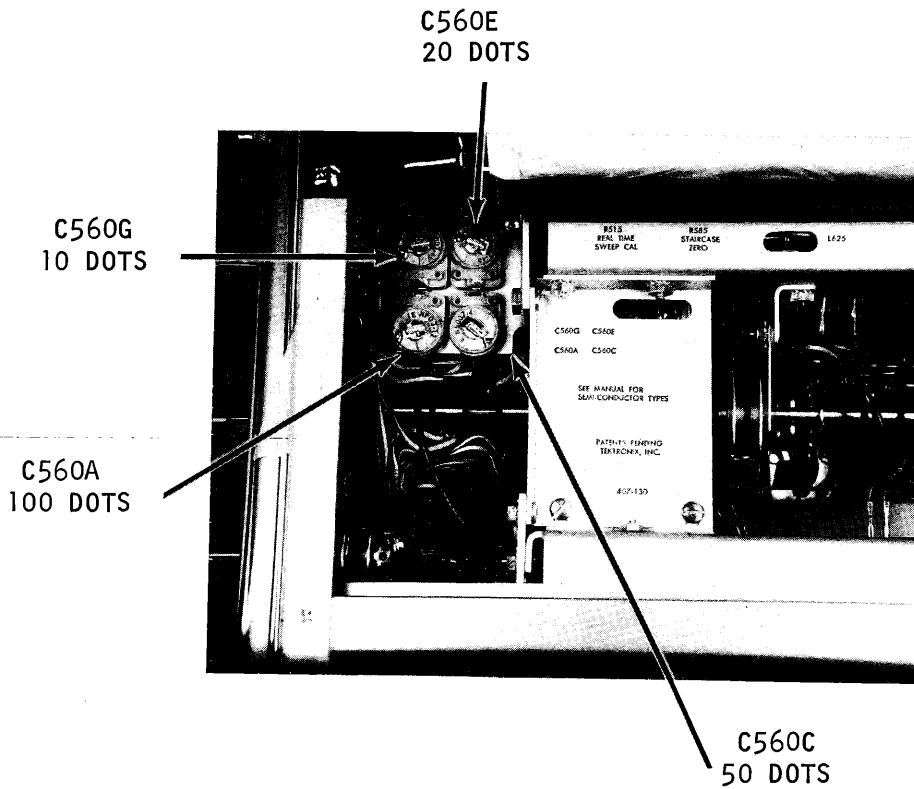

FIGURE 25



**BLOCK DISCUSSION**

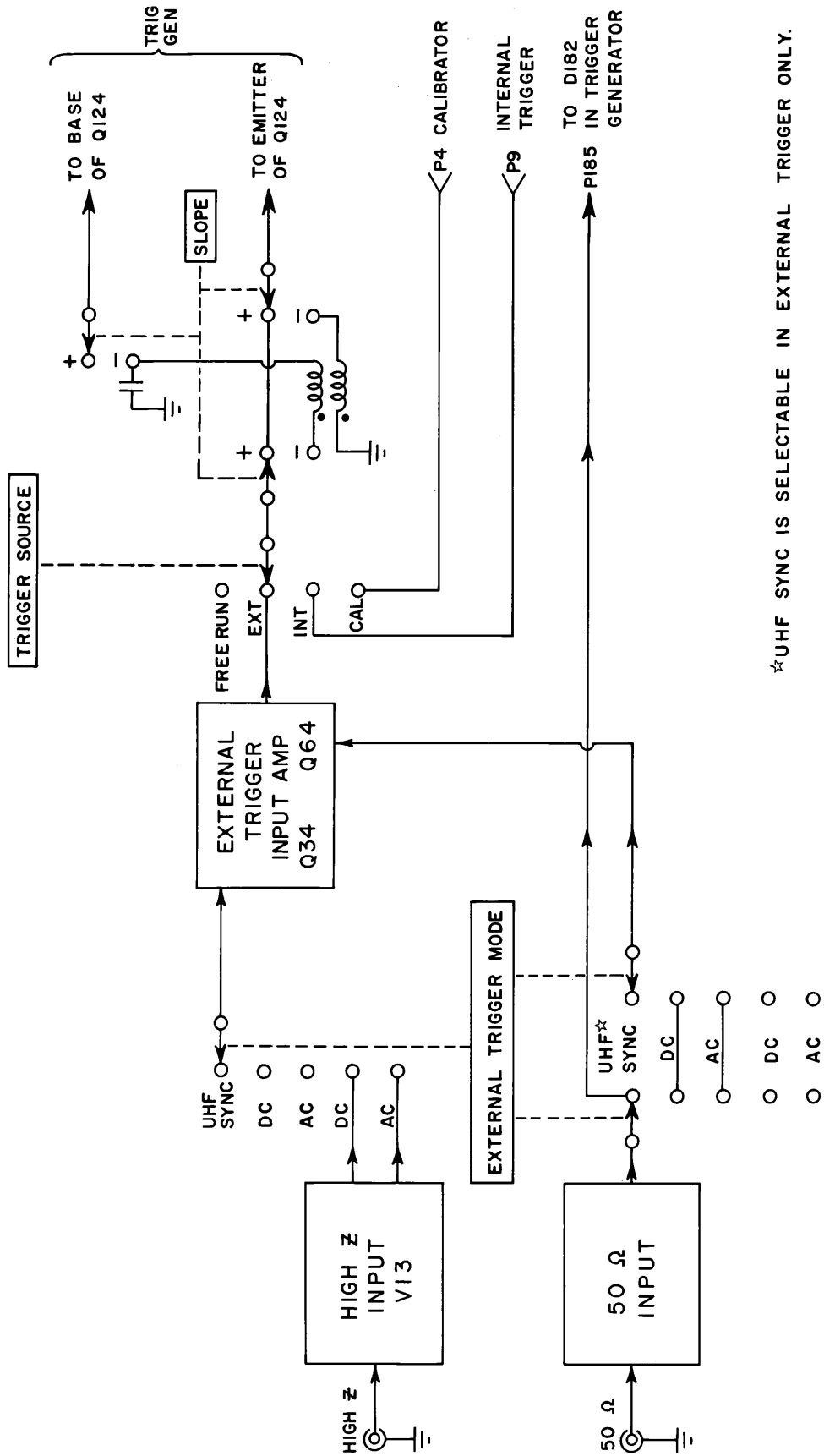

Fig 3-1

TYPE 5T3 EXTERNAL TRIGGER INPUT  BLOCK DIAGRAM

B-5T3-0002  
I-15-65 jg

## EXTERNAL TRIGGER INPUT

The EXTERNAL TRIGGER INPUT consists of an High Z Input, 50 $\Omega$  Input, External Trigger Input Amp, and portions of the TRIG SOURCE and SLOPE switching. The block diagram is shown in figure 3-1.

A type 8056 nuvistor, V13, is used as a CF input stage for the High Z Input. Protection from overloads is provided by D5 and D7. In AC coupling, the signal passes through C1, a .001 cap. to the grid. The 1 Meg Zero, R10 - 2.5k, is adjusted for 0 volts at point AH (ec board connector). The shunt combination of R15-C15, 9.1k - 7.5 pf, in series with R20, a 1k, form a 10:1 divider.

Q34 and Q64 are used as a transistor inverter pair. This stage has a current gain of 1. Q34 is an EF whose output drives the base of Q64. Degeneration in the emitter circuit of Q64 controls the stage gain. In the High Z input mode, the primary of T55 is tied to signal ground. The emitter Z of Q64, is the emitter-base resistance, 11 $\Omega$ , and R57, 39 $\Omega$ . The collector load is a 50 $\Omega$  transmission line which is always terminated in 50 $\Omega$ . In the 50 $\Omega$  Input DC coupled mode, the DC component of the signal is applied to the base of Q34 through the primary of T55 and the EXT TRIG MODE switch. R49 is a 50 $\Omega$  termination for the primary of T55. The high frequency component of the trigger signal is applied to the emitter of Q64 through T55, a transformer inverter. The signal at the collector of Q64 is 180 $^\circ$  out of phase with the signal at the input connectors. For low frequency signals or for High Z Input signals, Q64 is a common emitter stage and for high frequency signals or AC coupling of the 50 $\Omega$  Input, Q64 is a common base stage. The crossover point is about 3 MC in 50 $\Omega$  Input DC coupling. The 50 $\Omega$  Zero, R83 - 2.5k, is adjusted for 0 volts at J80 with no input signal.

In UHF SYNC, the External Trigger Input Amp is bypassed and the signal is applied directly to the TRIGGER GENERATOR through a 50 $\Omega$  transmission line. In the High Z Input modes, R53 terminates the input connector in 50 $\Omega$ .

The TRIG SOURCE switch selects CAL, INT, EXT, or FREE RUN. The unused portions of this switch are terminated in 50 $\Omega$ .

In + SLOPE operation, the signal is applied directly to the emitter of the Trig Amp in the TRIGGER GENERATOR. The signal is terminated in 50 $\Omega$  at the emitter of the Trig Amp. In -SLOPE operation, the high frequency component is applied to the emitter of the Trig Amp through T97, a transformer inverter. The DC component is applied to the base of the Trig Amp through the primary of T97. R99 terminates the base signal in 50 $\Omega$ .

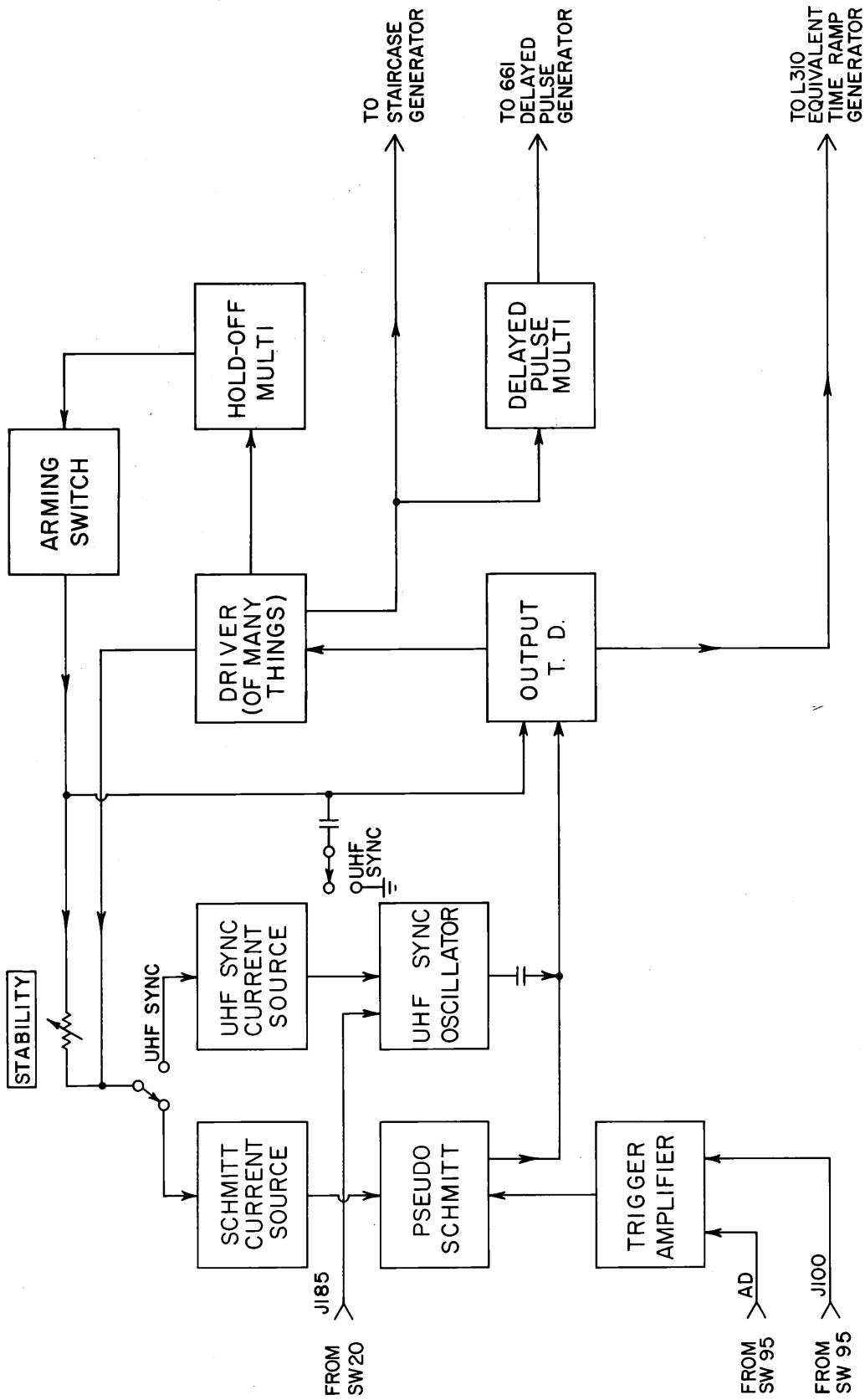

Fig 3-2

TYPE 5T3 TRIGGER GENERATOR  
BLOCK DIAGRAM

2

B-5T3-0003  
I-18-'65 jg

### TRIGGER GENERATOR

The TRIGGER GENERATOR consists of the Trigger Amplifier, Schmitt Current Source, Pseudo Schmitt, UHF SYNC Current Source, UHF SYNC Oscillator, Output TD, Driver (of many things), Hold-Off Multi, Arming Switch, and Delayed Pulse Multi. Figure 3-2 shows the block diagram.

The TRIGGER GENERATOR sends signals to STAIRCASE GENERATOR, EQUIVALENT TIME RAMP GENERATOR, and the Delayed Pulse Generator in the 661 main frame. The circuitry of the TRIGGER GENERATOR can be divided into three closed loops; the Hold-Off loop which consists of the Output TD, Driver, Hold-Off Multi, and the Arming Switch; the Pseudo Schmitt loop which consists of the Trigger Amplifier, Schmitt Current Source, Pseudo Schmitt, and the Hold-Off loop; and the UHF SYNC loop which consists of the UHF SYNC current Source, UHF SYNC Oscillator, and the Hold-Off loop.

Since the Hold-Off loop is common to the other loops, it will be considered first. Figure 3-3 shows the block diagram and Figure 3-4 shows the ladder diagram. We will assume the hold-off switching has been completed and we are awaiting a trigger pulse from the Pseudo Schmitt or the UHF SYNC Oscillator. Under these conditions, the Hold-Off Multi, Q235-Q255 - a complementary multi, is in its "on" state. The emitter of Q235 is at about 1v and the collector of Q255 is approximately 0.7v. The saturated conditions of Q255 turns on the Arming Switch, Q214. Q214 provides arming biases for the Pseudo Schmitt (or UHF SYNC Oscillator), the Output TD, and the Driver. The Output TD, D305, is in its low state. The Output TD Bias, R210 - 1k, is adjusted to bring D305 almost to the knee of its curve. With D305 in its low state, the Driver, Q204, is off.

When Q204 is turned off, 2.5 ma flows from -100v through R249, R248, D227, the primary of T224, R222, and R220 to +19v. The anode of D227 is slightly higher than +12v. D228 and D233 are off and the hold-off cap, D230, in parallel with the hold-off caps on the timing switch, has +12v across it. The divider network, R230 and R233, keep the hold-off cap at +12v.

When a trigger pulse is sent to D305, the Output TD switches to its high state (waveform D). D305 turns on Q204. The voltage at the collector of Q204 drops almost to ground. The voltage at the junction of R220-R222 drops (waveform B) and D220 turns on, robbing the current from Arming Switch. The Schmitt Current Source or the UHF SYNC Current Source is now disabled.



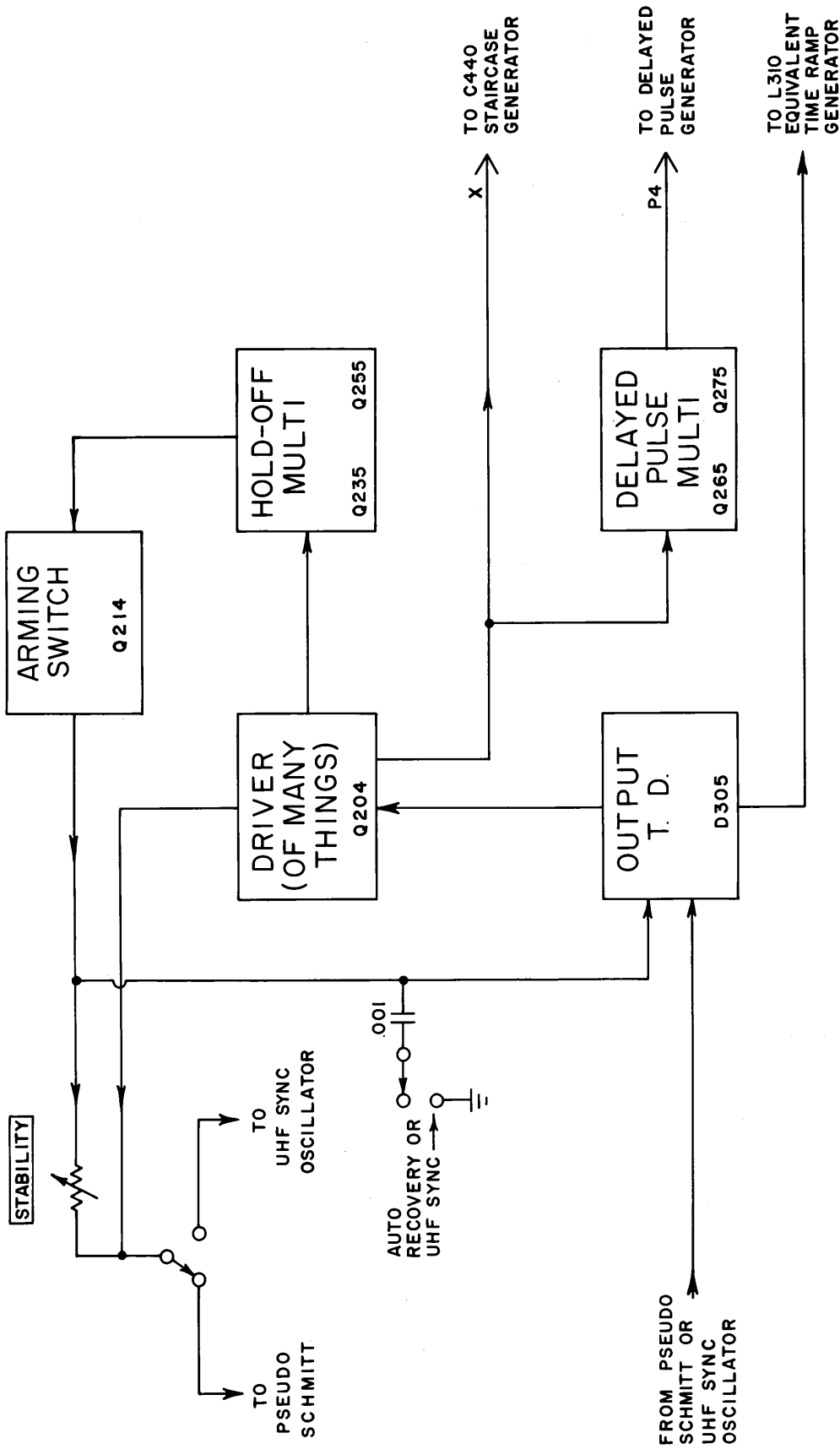

B-5T3-0006  
1-20-65 jg



TYPE 5T3 HOLD-OFF AND ARMING  
SIMPLIFIED BLOCK DIAGRAM

Fig 3-3

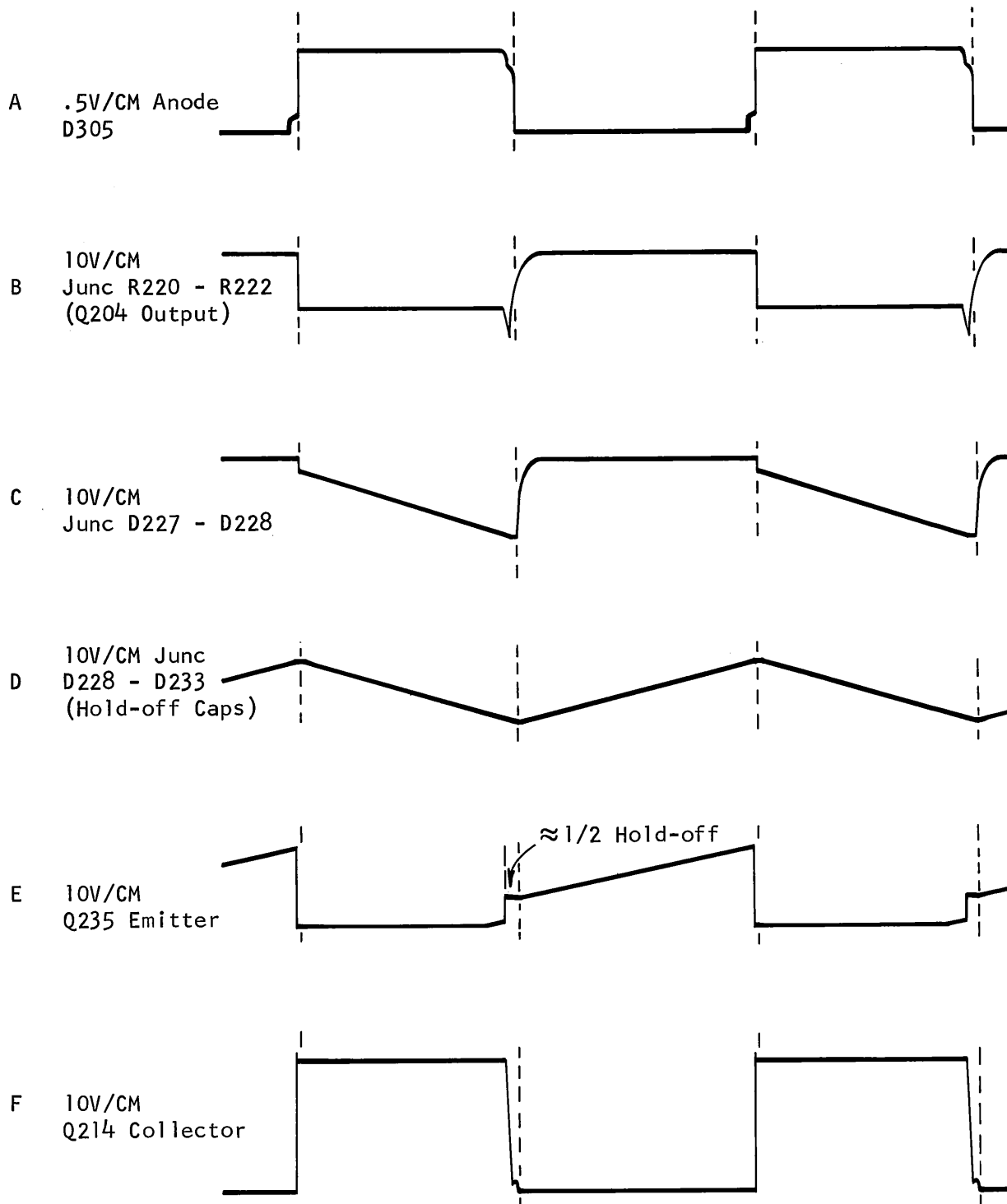

Hold-off Loop  
fig 3-4

When Q204 turns on, D227 is turned off. The 2.5 ma from -100v is now switched into the hold-off cap. D228 turns on and the hold-off cap charges toward ground from +12v. Waveform C shows the signal at the junction of D227 and D228 and waveform D shows the voltage change across the hold-off cap.

When the hold-off cap reaches +2v, D250 turns on. Q255 turns off and the Hold-Off Multi unlatches (waveform E shows the switching action at the emitter of Q235). When the Hold-Off Multi goes to its off state, Q214 is turned off (waveform F). Q214 removes the arming current from the Current Sources and the Output TD. D305 returns to its low state and Q204 is turned off.

When the hold-off unlatches, 2.5 ma which was flowing from the Hold-Off Multi through R235 to +100v is switched into the hold-off cap. The divider, R255-R253, sets the voltage at the collector of Q255 and base of Q235 at approximately +12v. When the charge on the hold-off cap reaches +12v, Q235 is turned on and the Hold-Off Multi regenerates. Q255 saturates and turns on the Arming Switch which supplies biasing currents to the Current Sources and the Output TD. The Hold-Off loop has now completed one excursion and the TRIGGER GENERATOR is now rearmed and ready to accept a trigger signal.

The block diagram for the Pseudo Schmitt loop is shown in figure 3-5 and the ladder diagram in figure 3-6.

Circuit operation of the Pseudo Schmitt was discussed in Section 2. We will concern ourselves with the circuits that affect the Pseudo Schmitt. The Trigger Amplifier provides a means of changing the current drive that is seen by the Schmitt. In + SLOPE operation, the Trigger Amplifier has a common base configuration. In - SLOPE operation, the Trigger Amplifier has a common base configuration to high frequency signals and a common emitter configuration to the DC component. The TRIG LEVEL controls sets the quiescent current of the Trigger Amplifier and therefore sets the threshold level of the Pseudo Schmitt. The emitter and the base circuits of Q124 present a  $50\Omega$  termination to the trigger signal.

When the trigger recognizer, D135, of the Pseudo Schmitt fires, an output pulse is developed across T135. The signal from T135 switches the Output TD into its high state. When D305 fires, hold-off action is initiated. When D305 is reset, about half-way through the hold-off sequence, the recharging action of C301 causes a small "glitch" at T135.

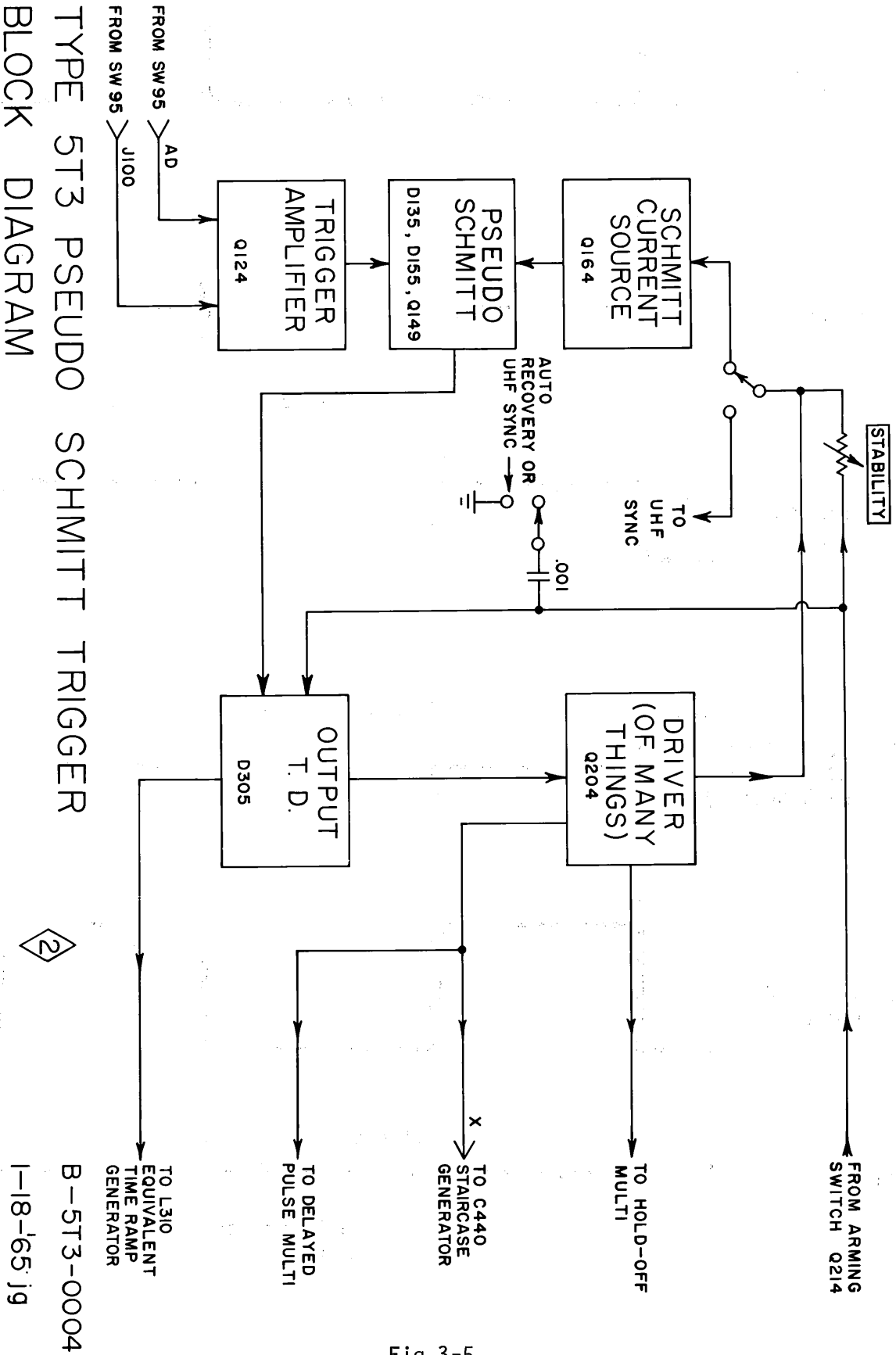
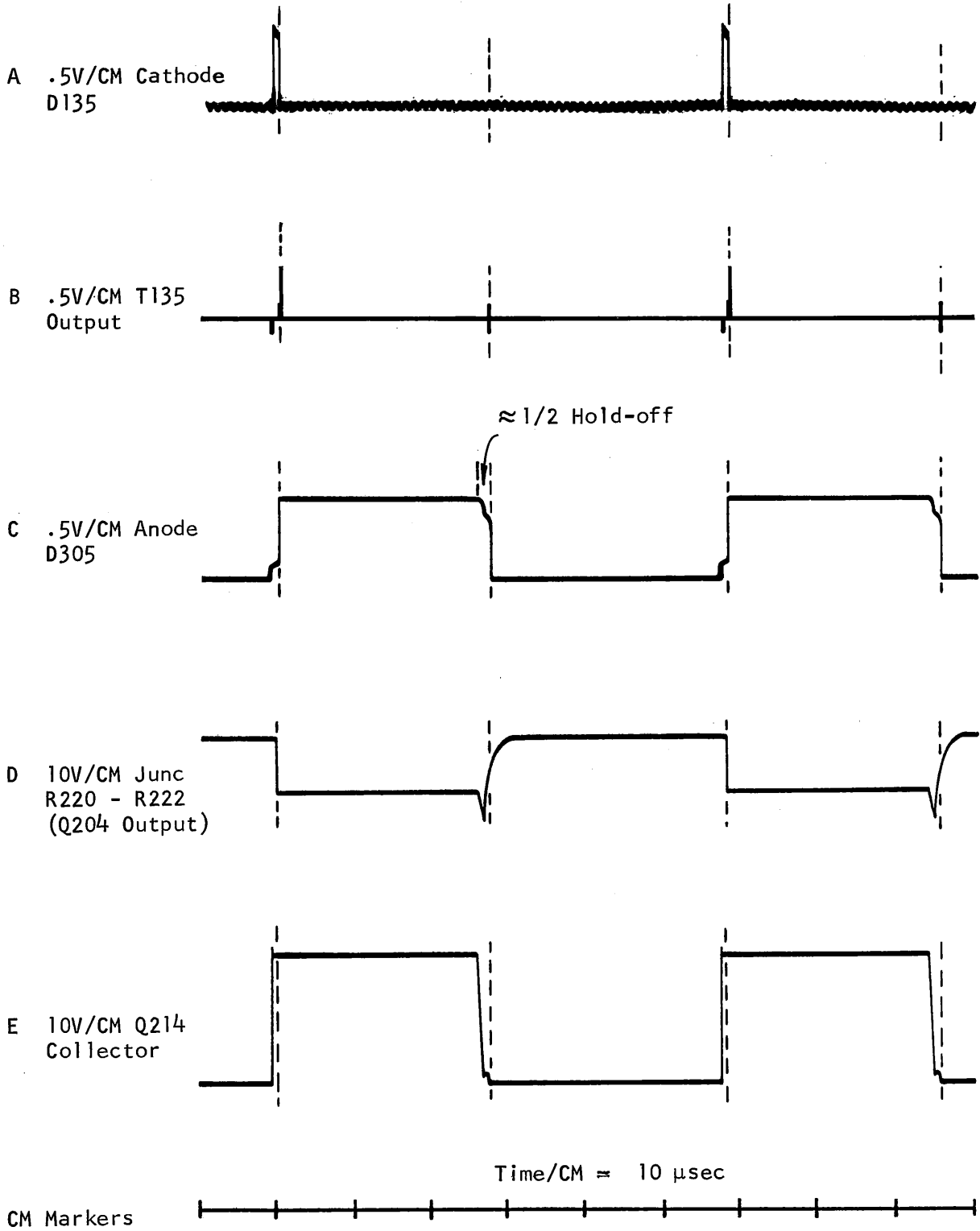
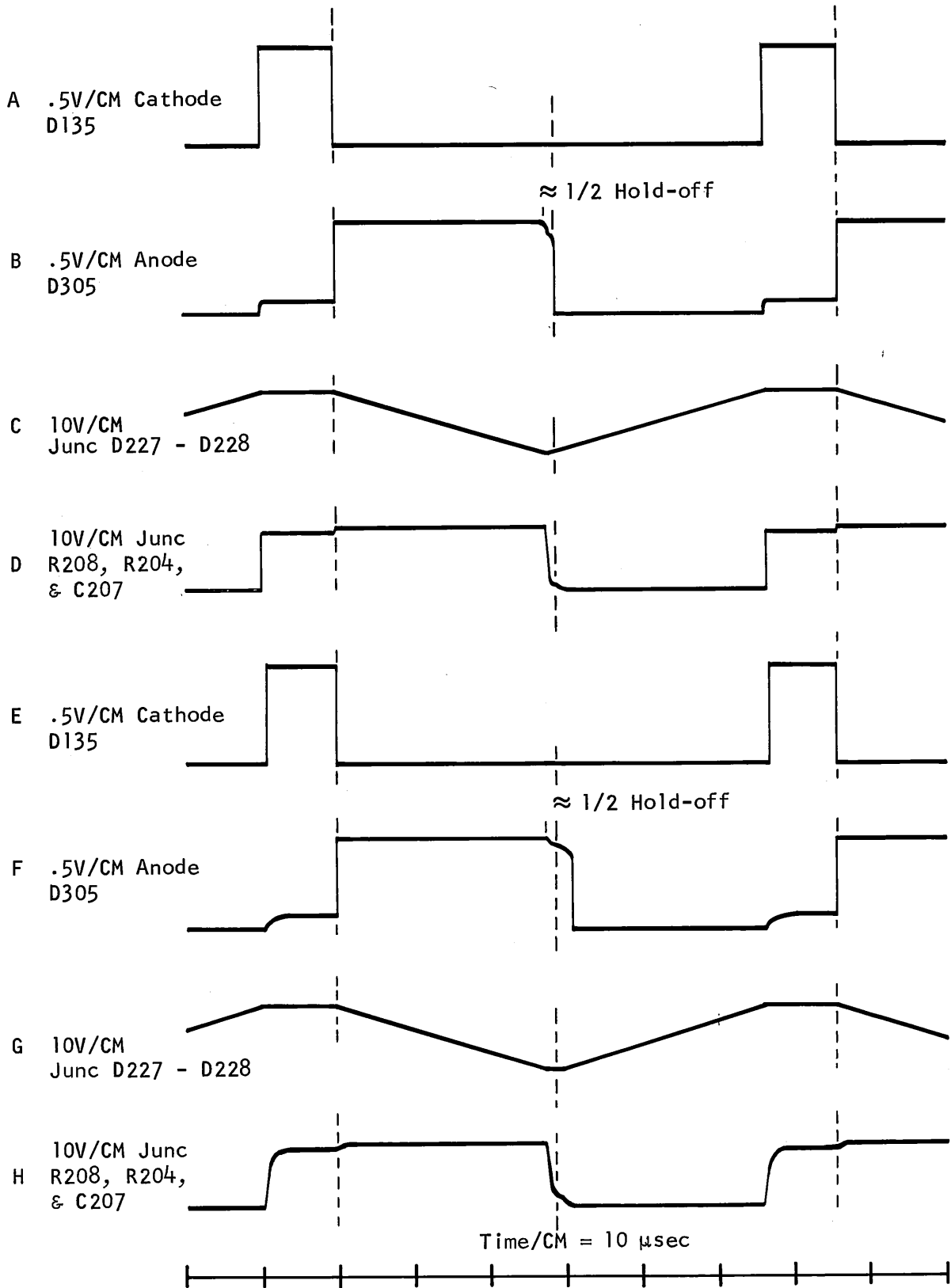

Fig 3-5

2



Pseudo Schmitt Loop  
fig 3-6



Pseudo Schmitt and Auto Recovery Comparison  
fig 3-7

When the AUTO RECOVERY Mode is selected, Q164 receives sufficient arming bias to fire D155 at the end of the hold-off operation. C207 is switched into the anode circuit of D305 which causes the arming bias of the Output TD to be delayed. Waveforms B and F in figure 3-7 are the anode of D305 in the Pseudo Schmitt Mode and AUTO RECOVERY Mode. Waveforms D and H show the junction of R208, C207, and R204 in these modes. It will be noted that the switching in AUTO RECOVERY has a definite RC delay.

The UHF SYNC block diagram is shown in figure 3-8 and the ladder diagram in figure 3-9. C207 is again switched into the anode circuit of D305. In UHF SYNC, the STABILITY control is adjusted so the trace will free run if a trigger signal is present. The output of D182 is superimposed on the arming bias of D305. When sufficient charge has been pumped into C301, D305 fires.

The UHF SYNC Current Source is turned on by robbing current from the Schmitt Current Source. A voltage divider from ground through D157, D158, R160 and R161 to +19v sets the base volts of Q164 and Q174. The base of Q164 is connected to the junction of R160 and R161. When the EXT TRIG MODE is set to UHF SYNC, the base of Q174 is connected to the junction of R160 and R158. The potential at the base of Q174 is now more negative than the potential at the base of Q164. Q174 will now turn on and rob the current from Q164. D185 in the emitter circuit of Q164 is a steering diode that causes Q164 to turn off. D175 in the emitter circuit of Q174 is a protection device.

The Delayed Pulse Multi does not belong in any of the aforementioned closed loops. This complimentary multi will produce an output pulse each time Q204 is turned on. This pulse is approximately 500 nsecs wide.

During quiescence, the multi is on. 15 ma flows from -19v through R289, 1.2k, through Q265 and Q275, and R275 1k, to +19v. Very little current flows into the Delayed Pulse Generator in the 661.

When Q204 turns on, coincident with D305 switching to its high state (waveform A in figure 3-10), a large signal is developed across the secondary of T224. Waveform D shows the signal as seen differentially across the emitter-base junction of Q275, a germanium transistor, and from the anode to cathode of D263, a silicon diode. The signal at the emitter is negative going and is positive going at the base, which causes Q275 to turn off and the multi to unlatch. Waveforms B and C show the actual base and emitter signals. When

TYPE 5T3 UHF SYNC TRIGGER  
SIMPLIFIED BLOCK DIAGRAM

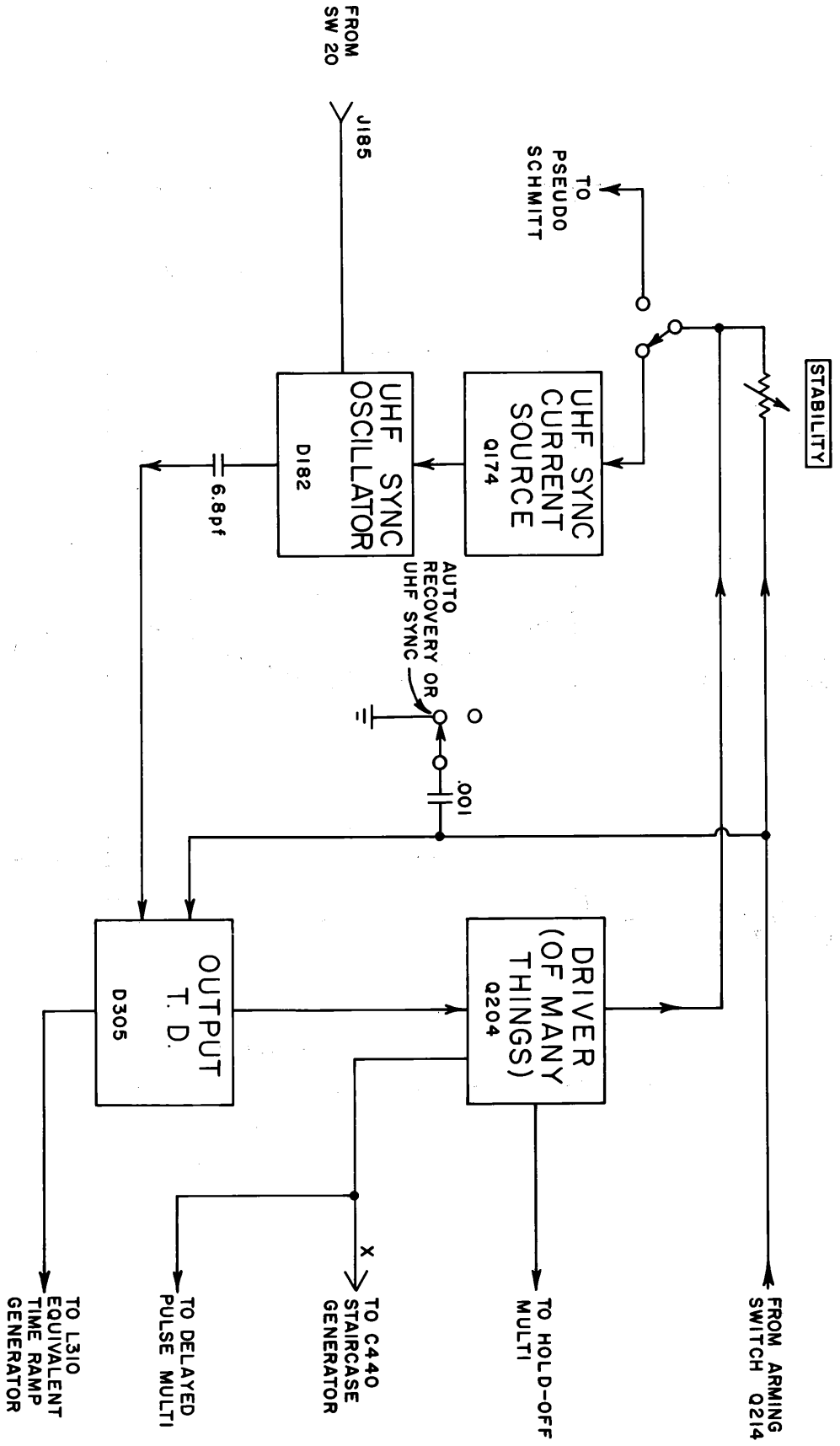
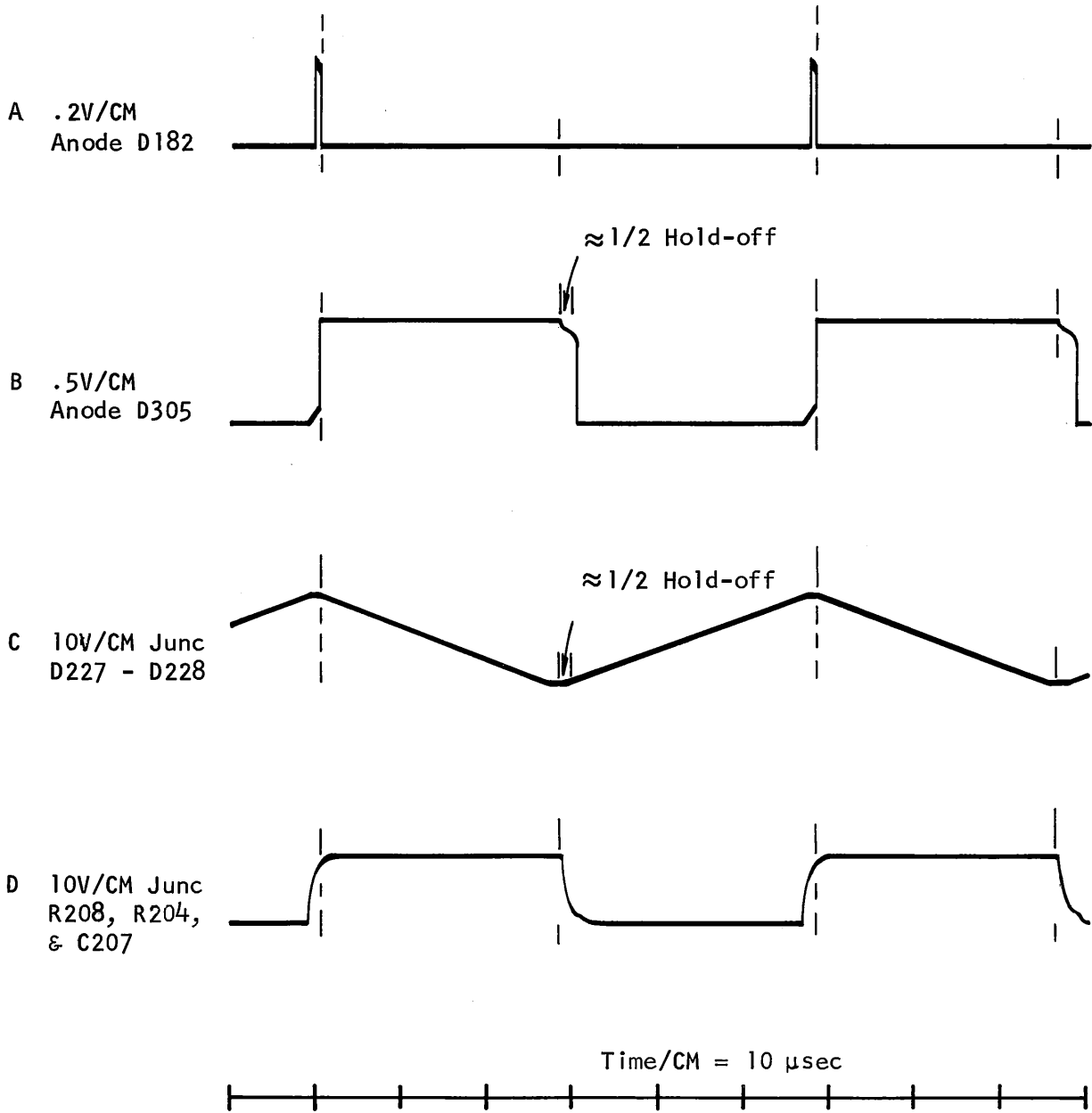

Fig 3-8

B-5T3-0005  
I-18-64 Jg





UHF SYNC Loop  
fig 3-9

A .5V/CM Anode  
D305

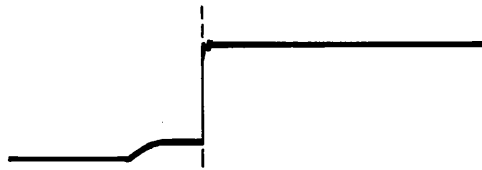

B 5V/CM Cathode D263  
(Q275 Base)

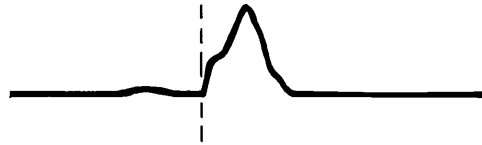

C 5V/CM Q275  
Emitter



D .5V/CM A-B  
A - Cathode D263  
B - Q275 Emitter  
B is inverted

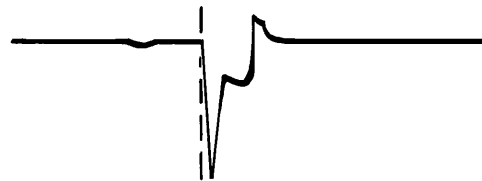

E 1V/CM pin R  
(Delay Out)

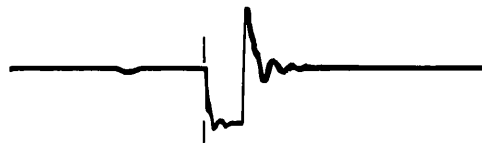

Time/CM = 1  $\mu$ sec



Delay Pulse Mult.  
fig 3-10

the multi unlatches, the 15 ma is applied to the Delayed Pulse Generator in the 661. The silicon diode, D263, keeps the signal from T224 from smashing Q275.

When the multi unlatches, C275 starts to charge to +19v through R275. As the voltage on C275 approaches +6.5v, D260 will conduct. Q275 turns on and the multi regenerates to its on state. The 100 $\Omega$  resistor, R224, which is in parallel with the secondary of T224 when the multi reverts to its on state. When the multi reverts to its on state, R224 - 100 $\Omega$ , which is across the secondary of T224, prevents the transformer from coupling a signal to the collector of Q204.

NOTES

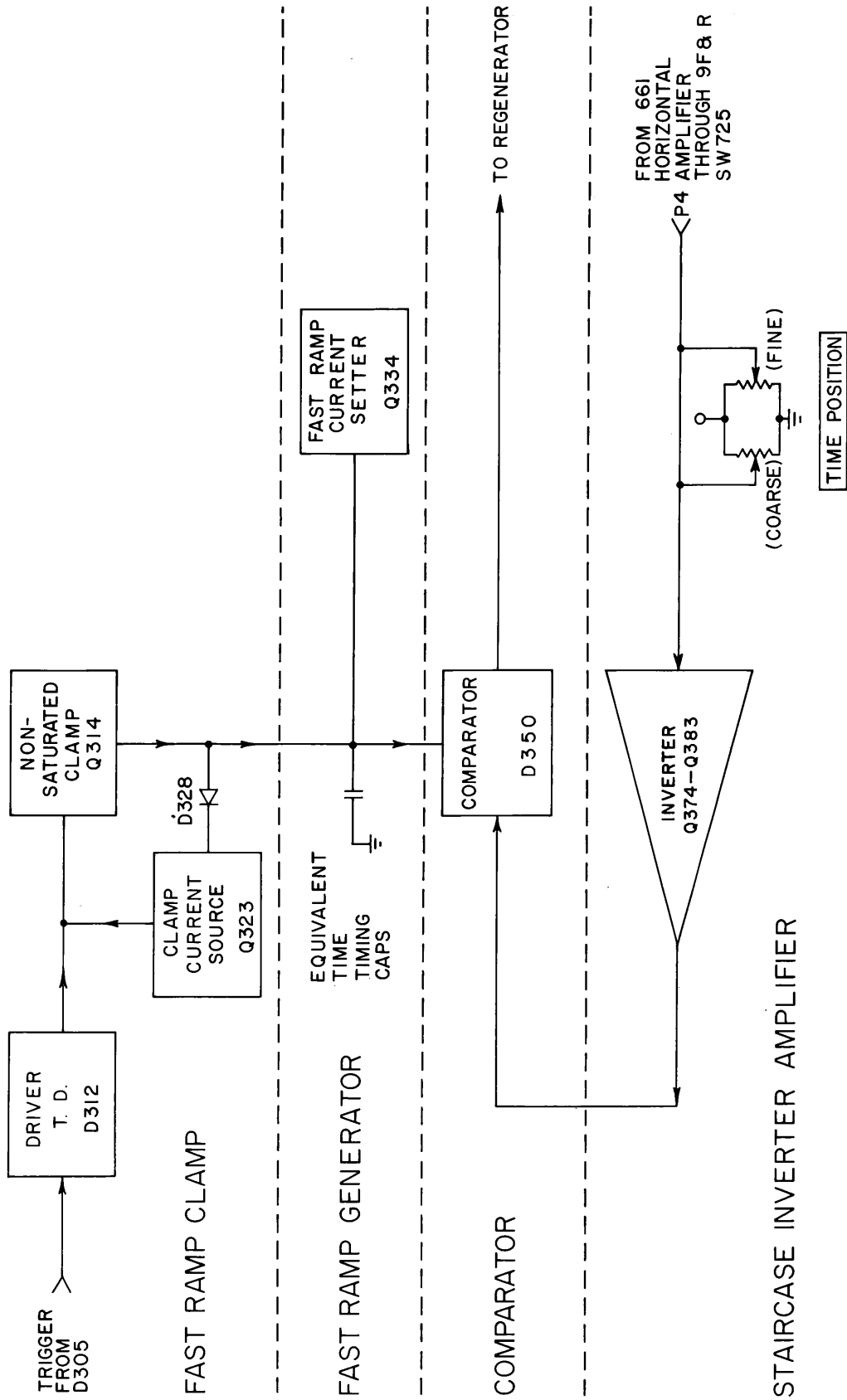

Fig 3-11

TYPE 5T3 EQUIVALENT TIME RAMP GENERATOR  
DETAILED BLOCK DIAGRAM

B-5T3-0007  
1-22-65 jg



## EQUIVALENT TIME RAMP GENERATOR

The EQUIVALENT TIME RAMP GENERATOR consists of the Fast Ramp Clamp, Fast Ramp Generator, Comparator, and the Staircase Inverter Amplifier. The block diagram is shown in figure 3-11. The ladder diagram is shown in figure 3-12.

The Staircase Inverter Amplifier receives two input signals. One input is a DC bias from the TIME POSITION controls. The DC bias controls the length of time the Fast Ramp will run before the first sample is taken. The DC bias will not change as the EQUIVALENT TIME/CM control is rotated. Thus time magnification occurs around the left hand side of the display. The other input signal is from a switch in the Horiz. Amp. in the 661 main frame. (In EXT or Manual the signal is from a Pick-off Amp in the Horizontal Amp.) This signal is applied to the Inverter through X1, X2, or a X5 divider for a 1,2,5 timing sequence. X10 and X100 dividers are also switched into the network to provide time magnification. This offset signal from the 661 main frame controls the length the Fast Ramp will run from one sample to the next sample.

The Staircase Inverter Amplifier is a feedback amplifier, commonly referred to as an operational configuration. The Inverter is composed of an EF input stage, Q383, and a common emitter output stage, Q374. The output signal from the collector of Q374 sets the anode voltage of D372, a GaAs diode. The output is a negative going signal.

The Inverter DC Level, R376 -  $250\Omega$ , is adjusted for 0 volts at the base of Q383. The Time Position Zero is adjusted for minimum display distortion with the TIME POSITION control set full CW.

The Fast Ramp Clamp consists of a Driver TD, D312, a Non-Saturated Clamp, Q314, and a Clamp Current Source, Q323. The Fast Ramp Clamp is a non-saturated, open loop clamp circuit. The purpose of the Fast Ramp Clamp is to control the starting point of the Fast Ramp. A simplified schematic of the Fast Ramp Clamp is shown in Figure 3-13.

One advantage of a non-saturated clamp circuit is that the starting voltage of the fast ramp excursion is regulated. We are assured that the fast ramp will start at the same point each time. The other advantage is that when the clamp is turned off, we do not have to contend with the stored charge of the clamp transistor.

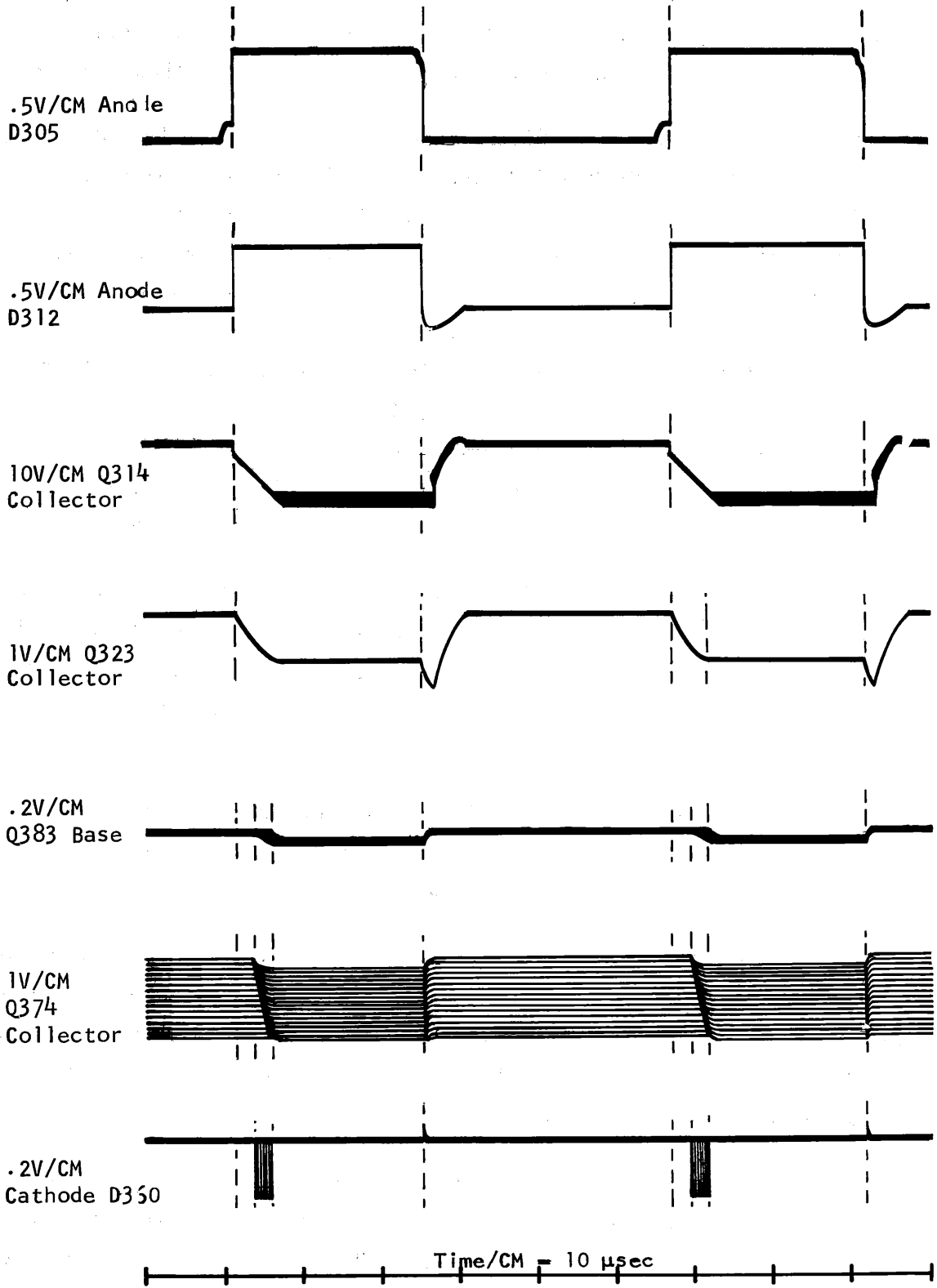

EQUIVALENT TIME RAMP GENERATOR  
fig 3-12

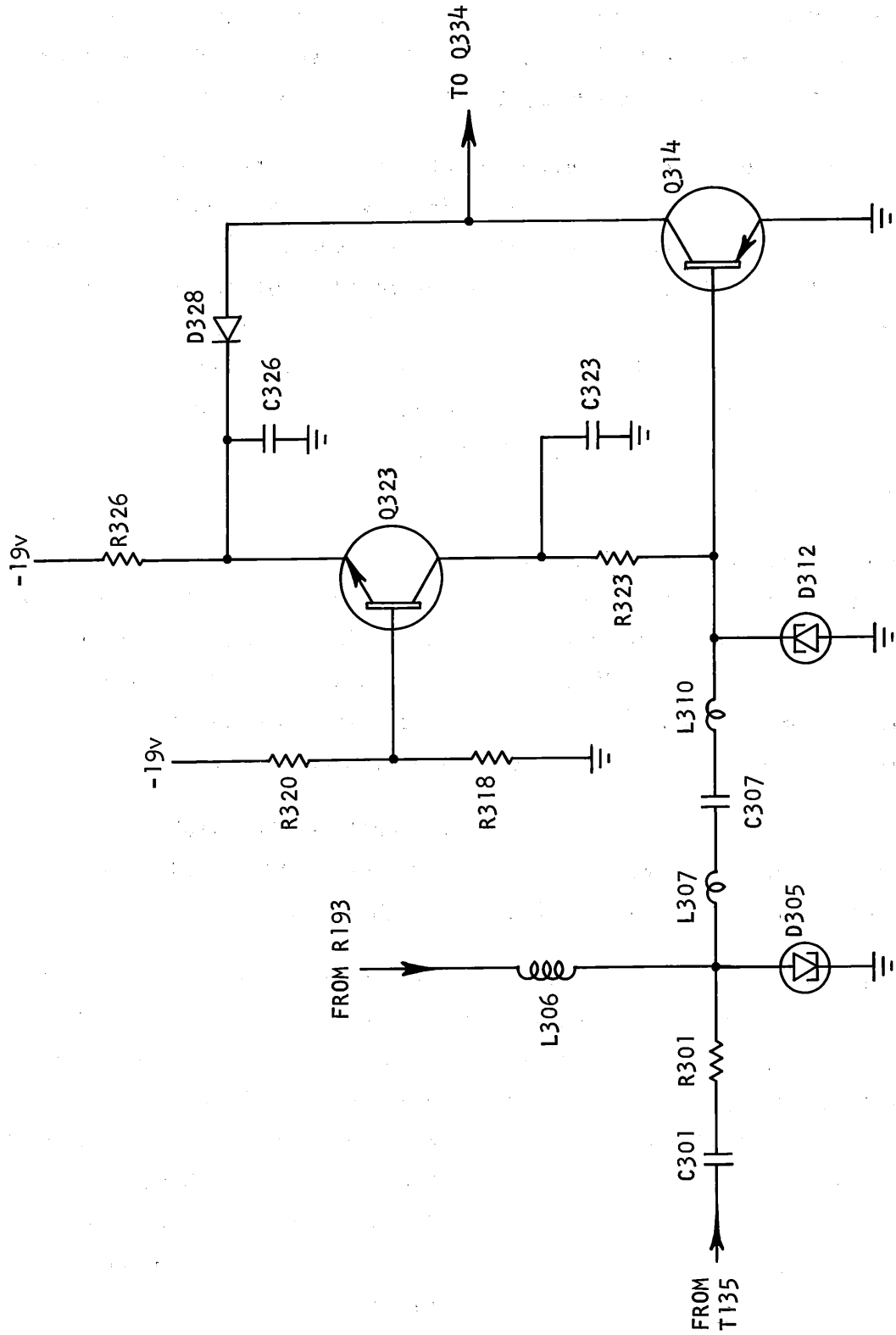

OUTPUT TD and FAST RAMP CLAMP SIMPLIFIED ROAD MAP

Fig 3-13



During the clamped condition, D312 is in its high state and Q314 is turned on. Q314 draws current from the Fast Ramp Current Setter, Q334, and from D328 through R326 to -19v. Q323 acts as a common base amplifier and supplies drive current for D312 and Q314. The collector current of Q323 is about 1 ma. The base of Q323 is held at -2v by the divider network, R318-R320.

If the voltage at the collector of Q314 goes positive, D328 will conduct more. The collector current of Q323 will decrease, which causes a decrease in base current at Q314. The voltage at the collector of Q314 will go negative offsetting the positive change at the collector of Q314. In the clamped condition, the base-emitter volts of Q314 is .4v. At .4v, D312 has a high impedance and requires little current to remain in its high state. The collector current of Q314 is limited by the amount of current available. Q314 can draw 7.5 ma from Q334 and 2 ma from D328 for a total collector current of 9.5 ma (design center).

The clamp is turned off when D305 switches to its high state. C307 robs current from D321 and Q314 to charge to the new volts of D305. D312 will switch to its low state and Q314 will turn off. The 7.5 ma that was flowing in the collector circuit of Q314 is switched into the Fast Ramp Timing Caps. D328 will turn off when Q314 turns off. 3 ma from -19v through R326 and Q323 will flow into D312 to bias the Driver TD towards the knee of its curve.

The clamp will revert to the clamped condition when D305 returns to its low state. C307 will discharge to the low state volts on D305 and pump current into D312 which switches D312 to its high state.

Approximately 7.5 ma from Q334 is switched into the timing caps when the clamp is turned off. Q334 is a constant current source which is longtailed to -100v. This 7.5 ma current passes through R345, the Comp Level, and D350, the Comparator, and R347, which is in series with D350. The fast ramp will run down until D372 conducts. Current is switched out of the timing caps by D372 which causes D350 to go to its high state. When D350 fires, a signal is coupled across T350 to the REGENERATOR. The Comp Level, R345, is adjusted to bring D350 close to the knee of its curve. R345 can be adjusted too critically which will cause an erratic display.

The Fast Ramp excursion is limited by the clamp level and the negative excursion, Q334, can make before going into saturation. The maximum possible ramp excursion is from -2v to approximately -18v. On the fastest ramp rate all

the timing caps on the EQUIVALENT TIME/CM switch are disconnected. The timing for this ramp is determined by C343 in shunt with capacitances inherent within the ramp circuitry. The fastest ramp slope is 20 nsec and 7.5v. No arming current is provided for D350. The speed is such that D350 fires about 1 nsec after D372 conducts.

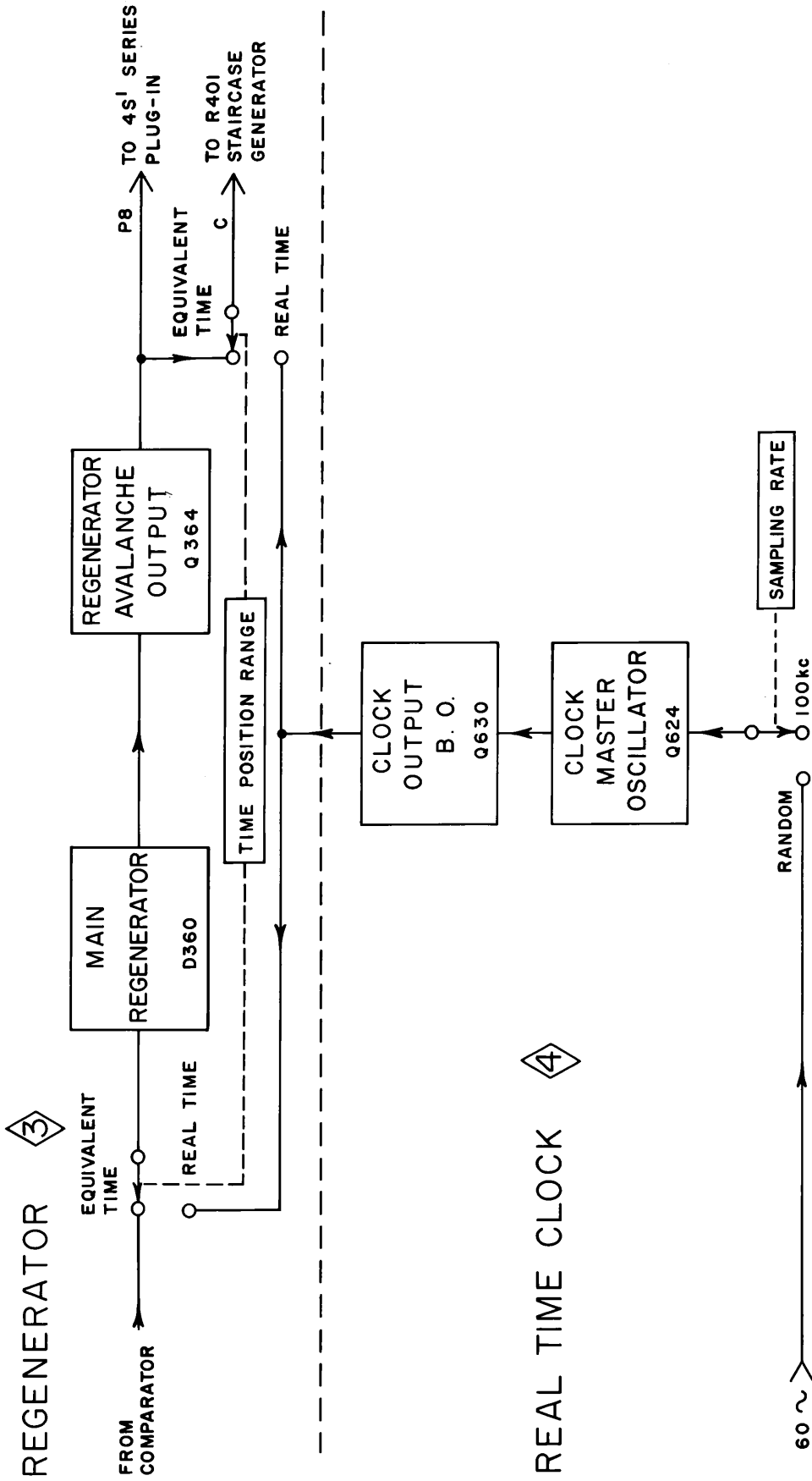

Fig 3-14

TYPE 5T3 REGENERATOR AND REAL TIME CLOCK  
BLOCK DIAGRAM

B-5T3-0008  
1-22-65 jg

## REGENERATOR

The REGENERATOR consists of the Main Regenerator and the Regenerator Avalanche Output, Q364. The block diagram is shown in figure 3-14 and the ladder diagram is shown in figure 3-15. When the Comparator fires, D360 is switched into its high state by the signal coupled through T350. Q364 avalanches when D360 switches into its high state. The output of Q364 is sent to the sampling plug-in as the interrogate pulse and to the STAIRCASE GENERATOR as the step signal.

In Real Time operation, the EQUIVALENT TIME RAMP GENERATOR is disabled. D360 will switch when it is energized by a signal from the REAL TIME CLOCK. Q364 will again send an interrogate pulse to the sampling plug-in.

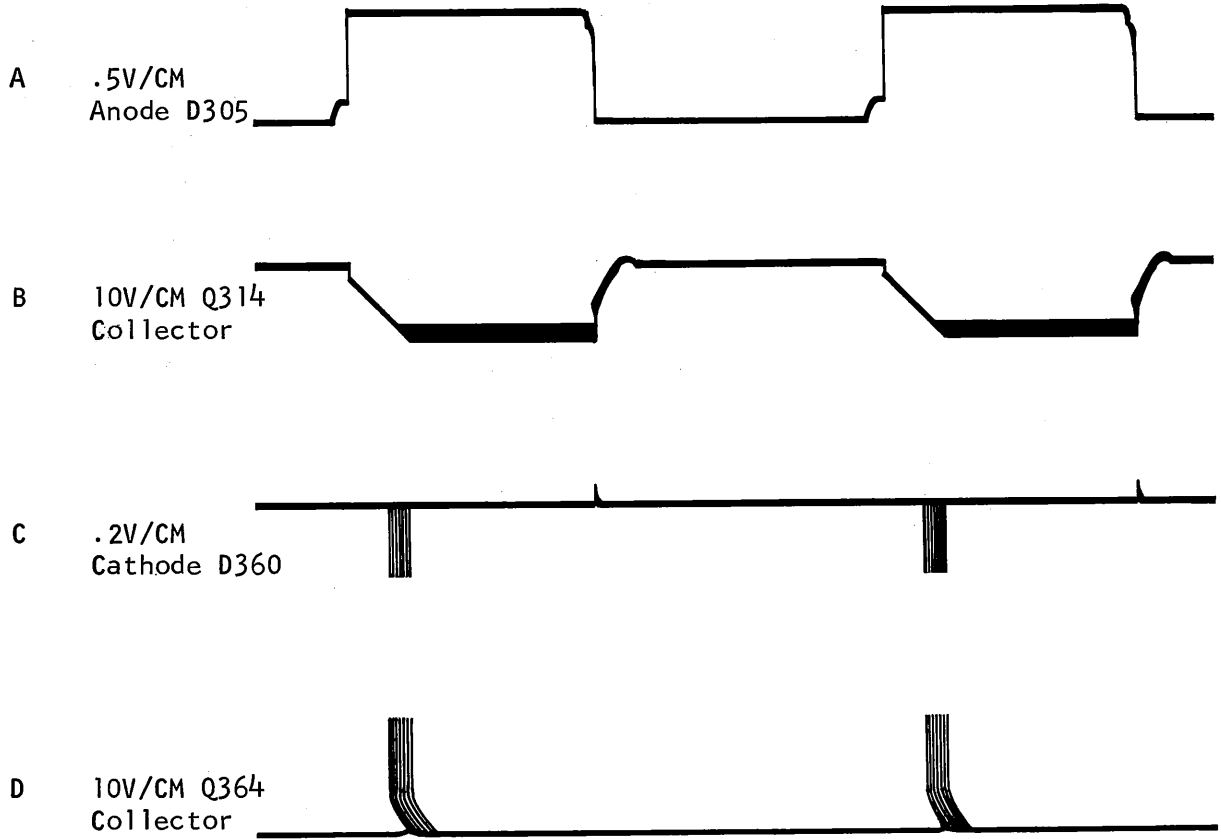

Time/CM = 10  $\mu$ sec

REGENERATOR  
fig 3-15

3-27

NOTES

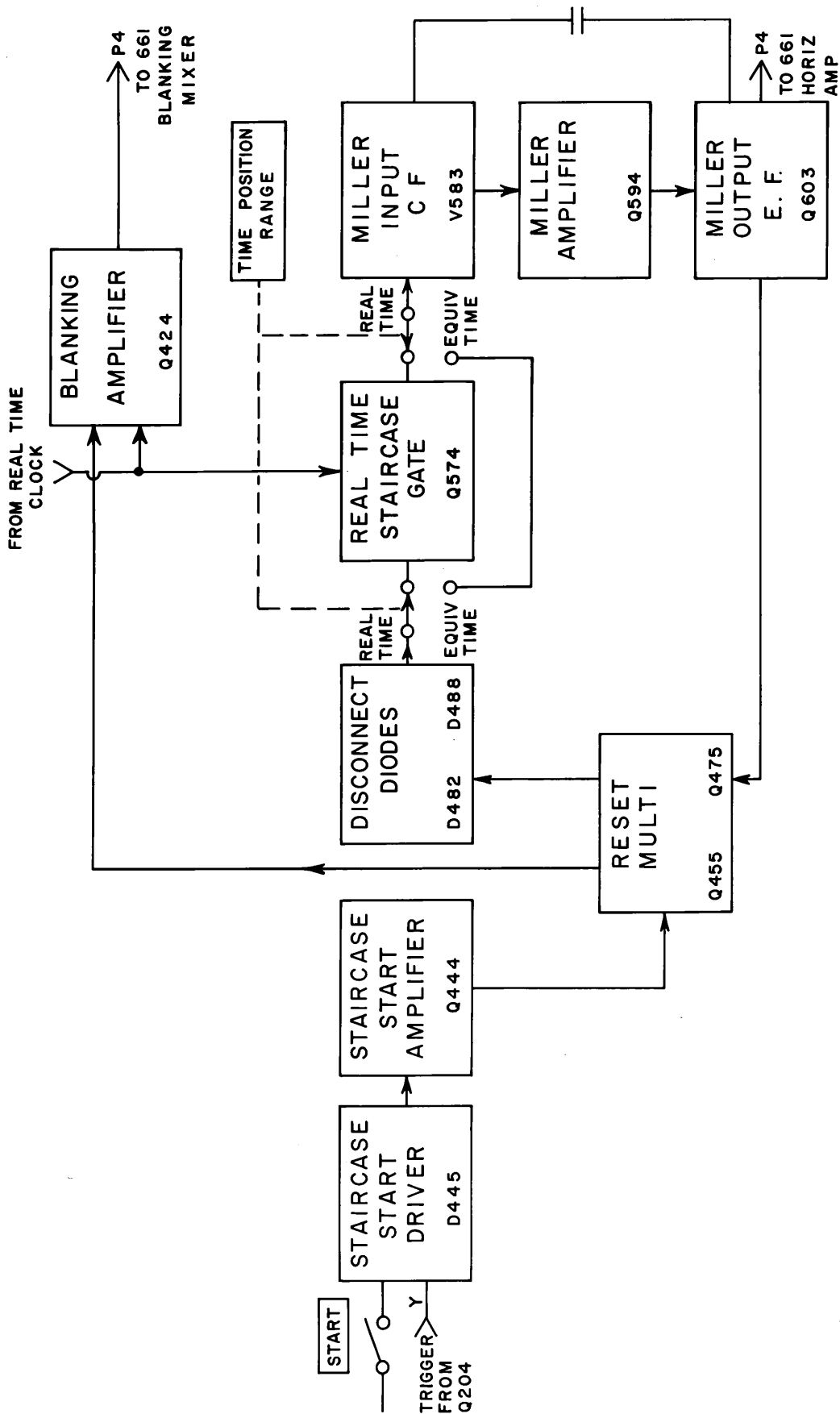

B-5T3-0010  
1-26-65jg



TYPE 5T3 STAIRCASE GENERATOR REAL TIME  
BLOCK DIAGRAM

Fig 3-16

## STAIRCASE GENERATOR

The STAIRCASE GENERATOR consists of a Staircase Start Loop, a Staircase Stepper circuit, and a Miller Run-Up circuit. The block diagram for Equivalent Time operation is shown in figure 3-16. The Staircase Start circuit consists of the Staircase Start Driver, D445, and the Staircase Start Amplifier, Q444. The ladder diagram for the Staircase Start circuit is shown in figure 3-17.

Q204 in the TRIGGER GENERATOR sends a signal to D445 which switches it into its high state. Q444 produces an output pulse each time D445 fires. The signal from Q444 turns on the Reset Multi which allows the Miller to sweep. The Reset Multi will see the negative going signal from Q444 only when it is turned off. The Reset Multi is turned off from the end of the sweep run-up, through the hold-off period, until the receipt of the next trigger pulse. In single sweep operation, the Staircase Start circuit is biased off, until the START button on the front panel is pushed. Then the Staircase Start circuit will accept the next pulse from the Trigger Generator.

The Staircase Stepper circuit consists of the Staircase Stepper, Q414, and the SAMPLES/CM switch. A ladder diagram for the Staircase Stepper circuit is shown in figure 3-18. Q414 produces an output signal each time the Regenerator Avalanche Output fires in Equivalent Time. Q414 sends a signal to the SAMPLES/CM switch and the Blanking Amplifier. The amplitude of Q414's output is controlled by the Dots Cal, R415.

The SAMPLES/CM switch selects the bucket and ladle caps which determine the signal amplitude that is seen by the Miller circuit. C560A-J are the ladle caps. The parallel combination of C495 and C493 form the little bucket and the fat bucket is formed by adding C490 in shunt with the little bucket. C490 is used only in the 1000 SAMPLES/CM and TIMED positions. D565 and D567 form a one-way gate that passes the charge from the ladle to the bucket and prevents the bucket from leaking charge between samples. In the 1000 and TIMED positions, C522 is switched in to shunt the hold-off cap, C611. The B- source is removed from the emitter of Q414 to shunt down the Staircase Stepper circuit during Real Time operation.

The ladder diagram for the Blanking Amplifier, Q424, is shown in figure 3-19. Q424 sends a blanking signal to the crt while the Miller is stepping and during the hold-off period. The Blanking Amplifier is energized by the Staircase Stepper in Equivalent Time operation and by the Real Time Clock in Real



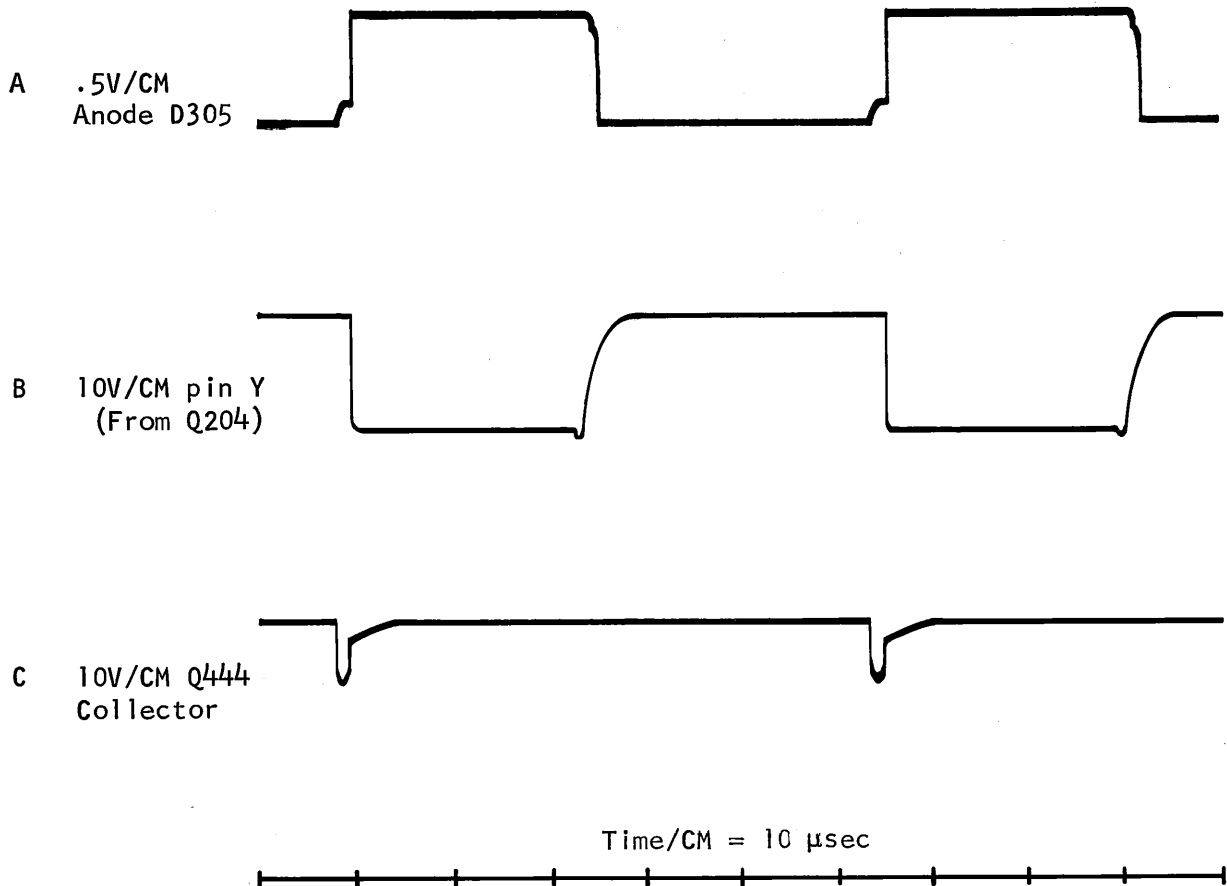

Staircase Start Circuit  
fig 3-17

Time operation. The output of the Blanking Amplifier is a positive going signal at pin AE.

The Miller Circuit consists of the Reset Multi, Disconnect Diodes, Miller Input CF, Miller Amplifier, and Miller Output EF. A ladder diagram is shown in figure 3-20.

When the Reset Multi is turned on by the Staircase Start circuit, the Disconnect Diodes are turned off. The Miller circuit will now accept an input signal from the Staircase Stepper in Equivalent Time operation. The step signal at the grid of V583 is negative going. The signal is amplified and inverted by Q594 and applied to the base of Q603. The output of Q603 is

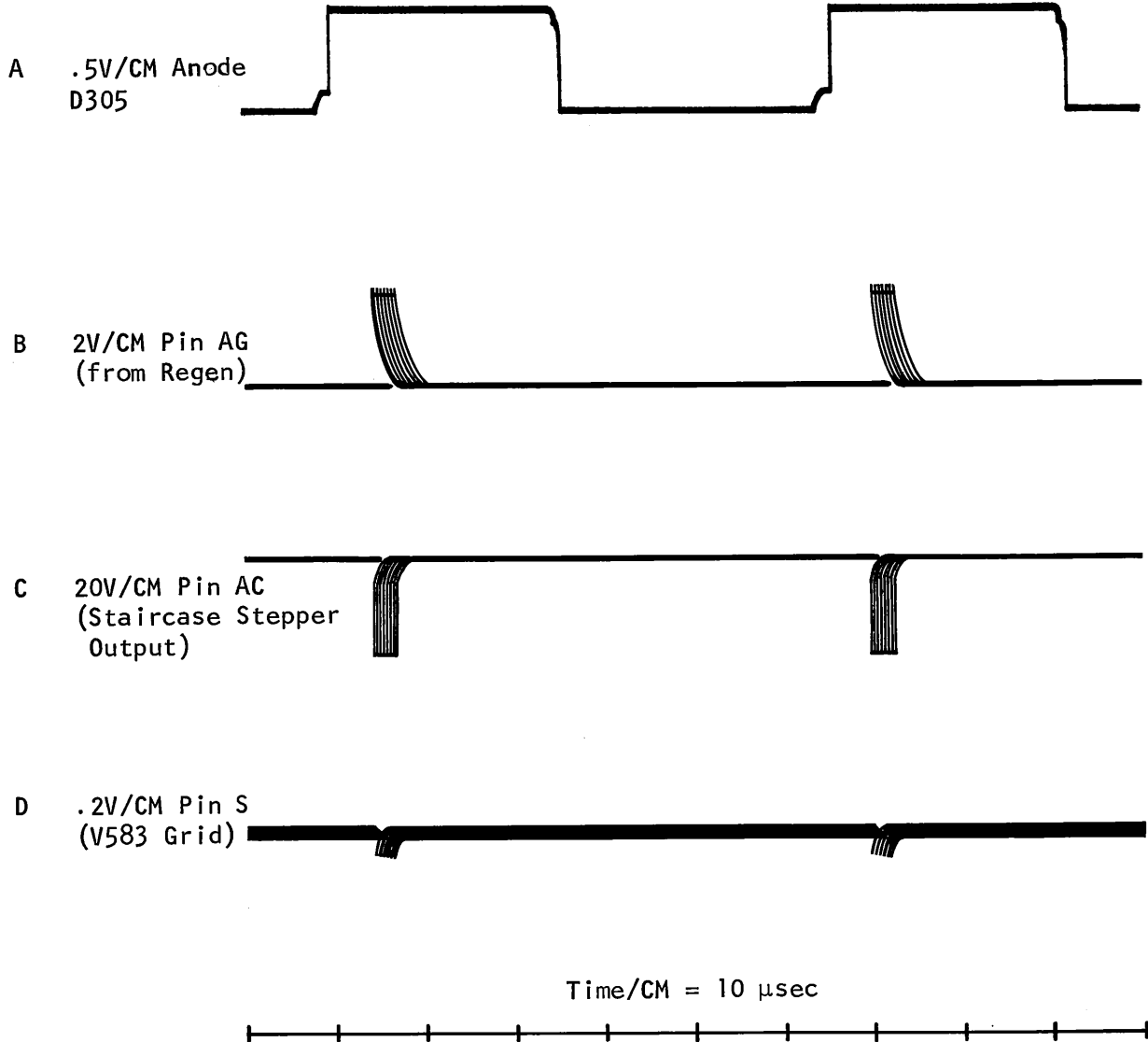

Staircase Stepper Circuit  
fig 3-18

applied to the 661 Horizontal Amplifier through P4. When the signal at pin T (sweep out) has run up to about 55v (Sweep Length - R612 set for 10.5 cm of sweep), D610 will conduct and hold-off will start. D610 will cause the Reset Multi to revert to its off state and the Disconnect Diodes will be turned on. The Miller will run down and the bucket caps discharge through D597 and Q594. The staircase is reset very close to 0 (zero) volts. When the Sweep Length is adjusted to maximum, the staircase will run to about 60v before resetting. The Staircase Zero, R585, is adjusted for 0 (zero) volts at pin T with a test scope.

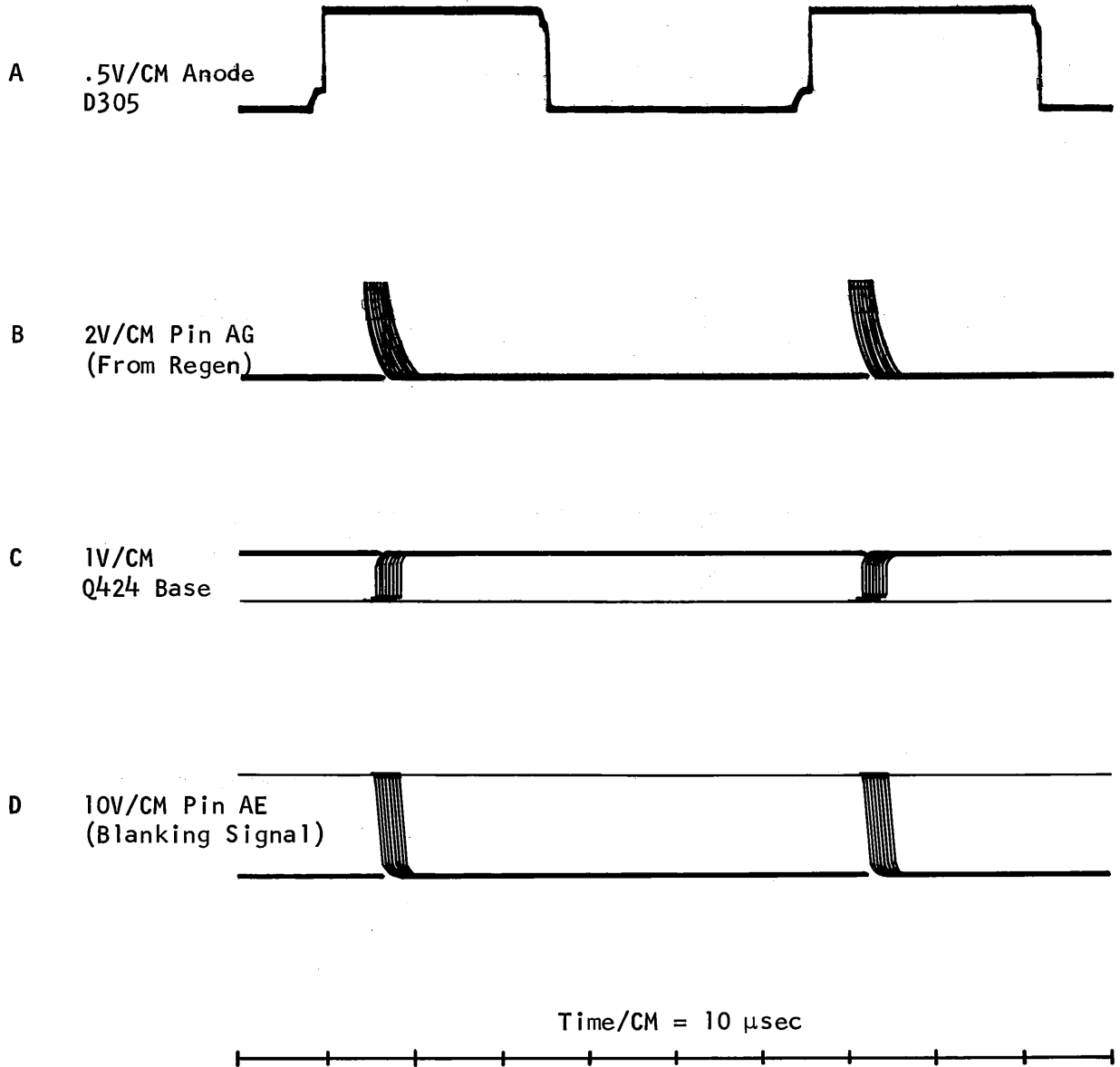

Blanking Amplifier  
fig 3-19

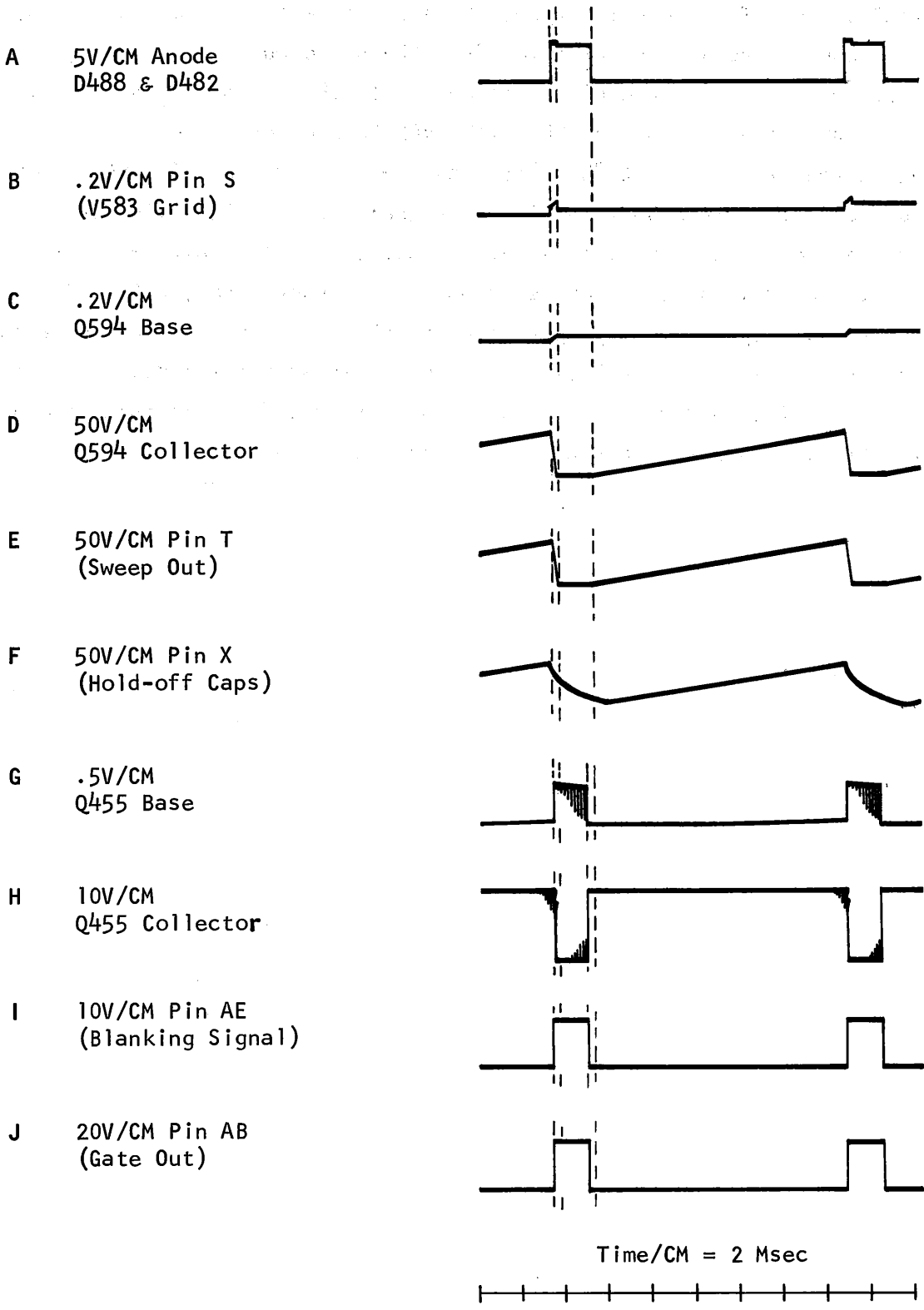

Miller Sweep Circuit  
fig 3-20

The block diagram for Real Time operation is shown in figure 3-21. In Real Time operation, the Real Time Staircase Gate, Q574, steps the Miller circuit. Q574 is normally off and will conduct when it receives a signal from the REAL TIME CLOCK. The sweep is stepped by a bucket and ladle circuit. C495 forms the bucket cap and is connected from the sweep out to the grid of V583. The other real time timing caps are connected to the sweep out and to -100 volts through the Sweep Cal and REAL TIME VARIABLE circuit. C493 and, depending on the sweep rate, C488, C486, and C490 in parallel with C493 form the ladle circuit. When Q574 receives a signal from the REAL TIME CLOCK it saturates and all the "timing caps" are connected in parallel. The charge on the ladle caps is divided between them and the bucket cap, C495. The Miller takes a step which is proportional to the time between the new sample and the last sample. Figure 3-22 is a ladder diagram for the Miller circuit in Real Time. The operation of the Staircase Start and the Blanking Amplifier is the same in Real and Equivalent Time operation.

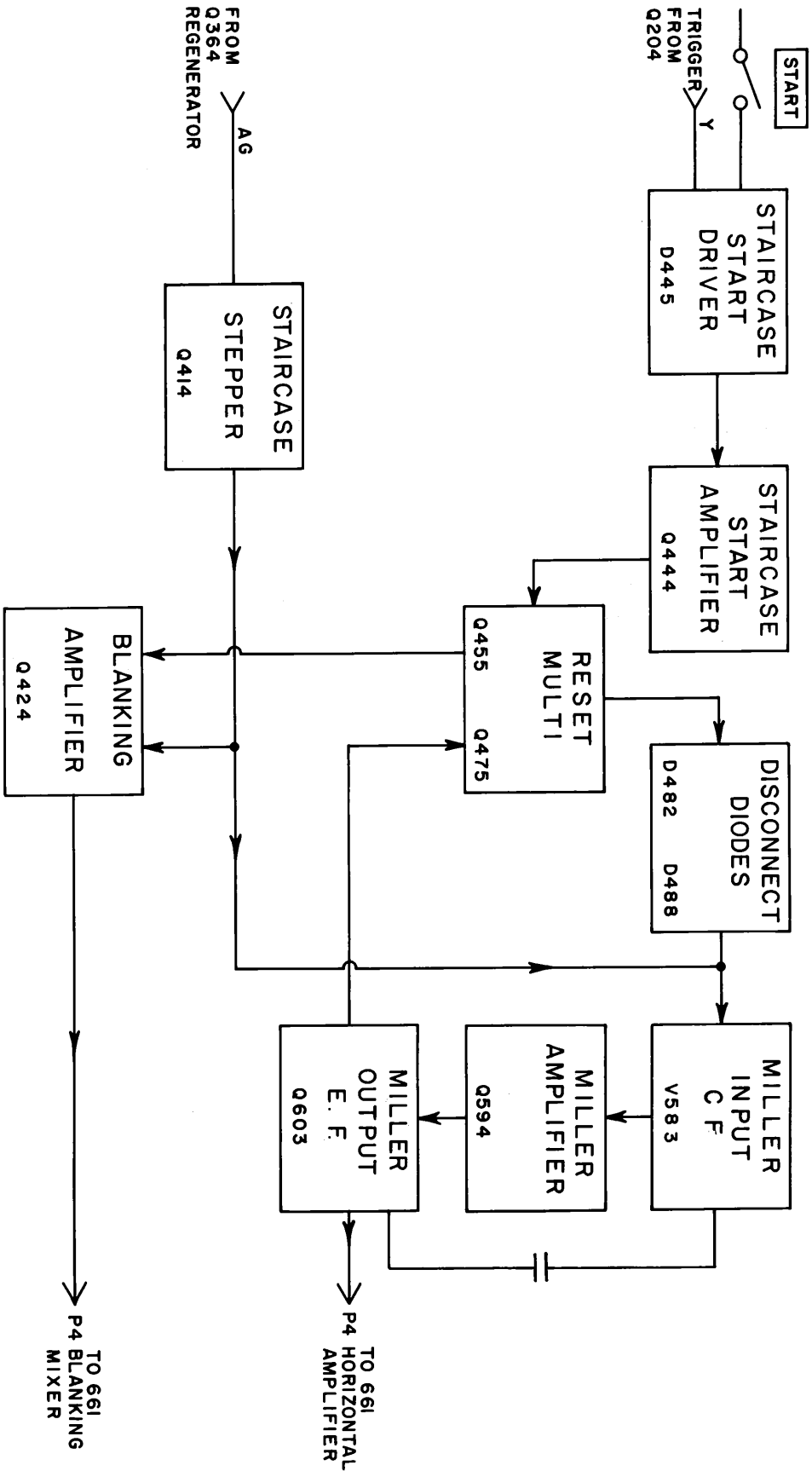

TYPE 5T3 STAIRCASE GENERATOR EQUIVALENT TIME  
BLOCK DIAGRAM



B-5T3-0009  
I-23-165jg

Fig 3-21

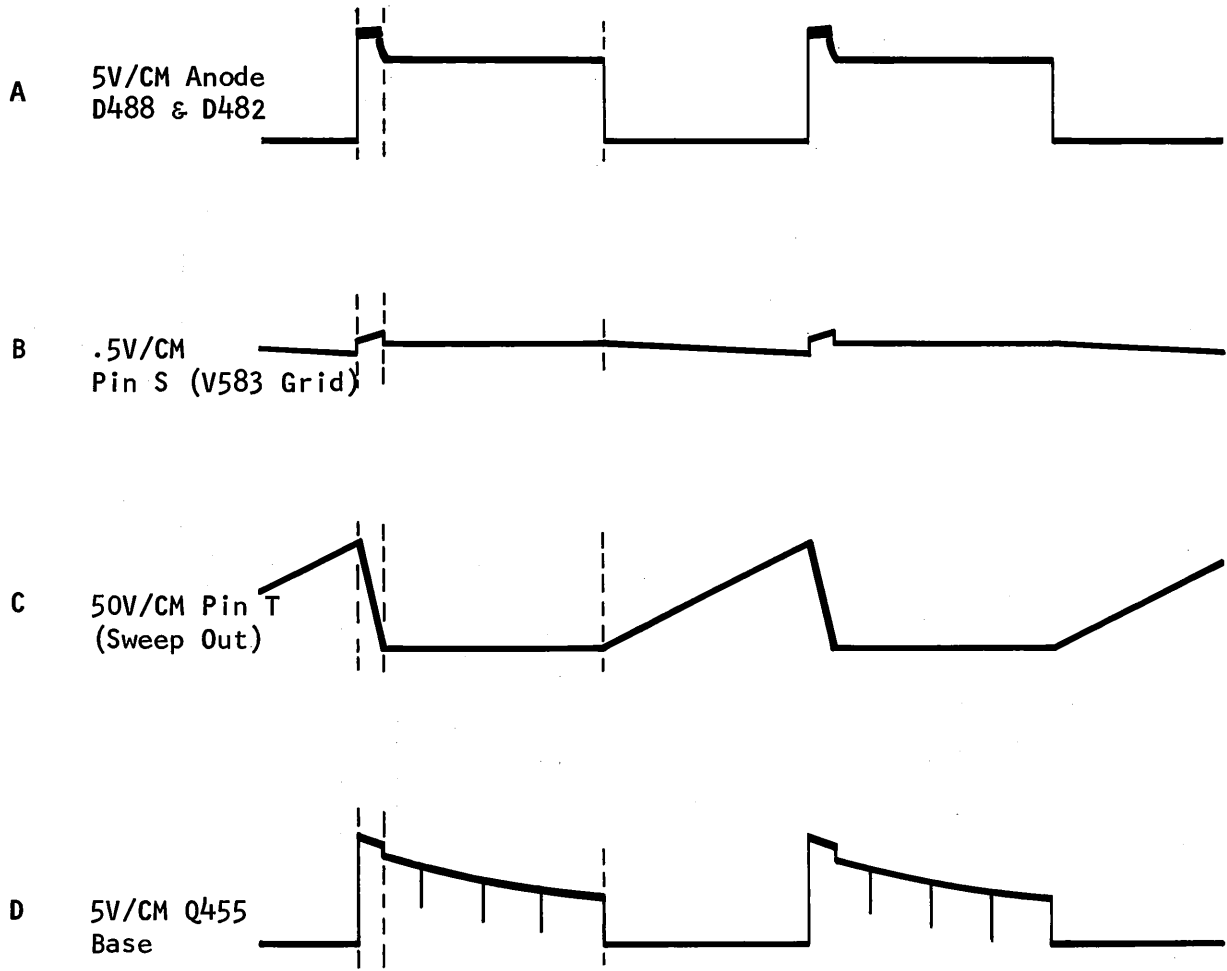

Time/CM = 1 Msec

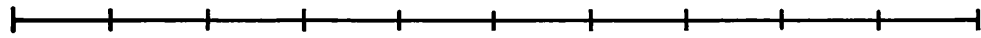

Miller Sweep Circuit in Real Time Sampling

fig 3-22

## REAL TIME CLOCK

The REAL TIME CLOCK consists of a Clock Master Oscillator, Q624, and a Clock Output B0, Q630. The block diagram is shown in figure 3-14. The ladder diagram for the REAL TIME CLOCK and associated circuits for 100 KC operation is shown in figure 3-23.

With the SAMPLING RATE switch in the 100 KC position, Q624 is a Colpitts oscillator. The feedback loop is from the emitter through the SAMPLING RATE switch to the tapped caps in the base circuit. L625 is adjusted for an oscillator frequency of 100 KC. When oscillator action turns on Q624, sufficient current is supplied to C632 to charge it from +19v to below ground. As the volts at the emitter of Q630 go below ground, D635 conducts and the B0 regenerates. The Clock B0 sends a signal through pin C to the REGENERATOR, through a secondary winding of the all purpose transformer, T635, to Q574, and through another secondary winding of T635 to Q424. A third secondary winding on T635 supplies the feedback signal to the base of Q630. During the regeneration period, C632 is recharged to +19v.

When the SAMPLING RATE switch is set to RANDOM, Q630 remains a free running B0 and Q624 becomes an hum current source for Q630. The ladder diagram is shown in figure 3-24. In RANDOM operation, the emitter of Q624 is tied to a 60 cps source. The current from Q624 that discharges C632 varies at a 60 cps rate. C632 will discharge from +19v to below ground in about 12.5  $\mu$ secs (center frequency). The 60 cps hum on the supply current FM modulates the discharge of C632 around the center frequency. Thus in a 100 KC or RANDOM operation, Q624 controls the frequency at which the B0 fires.



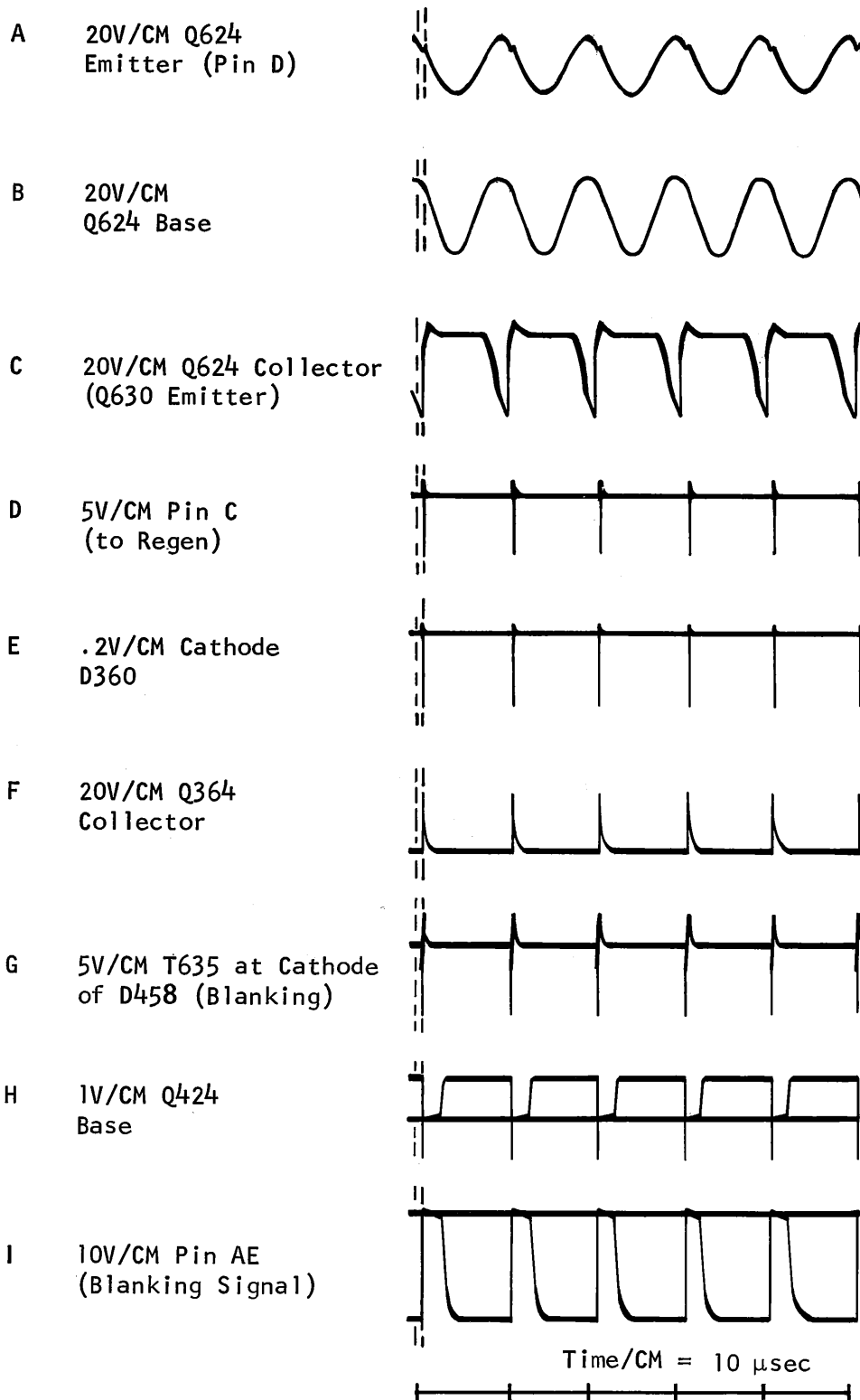

REAL TIME CLOCK and associated circuits at 100 KC  
fig 3-23

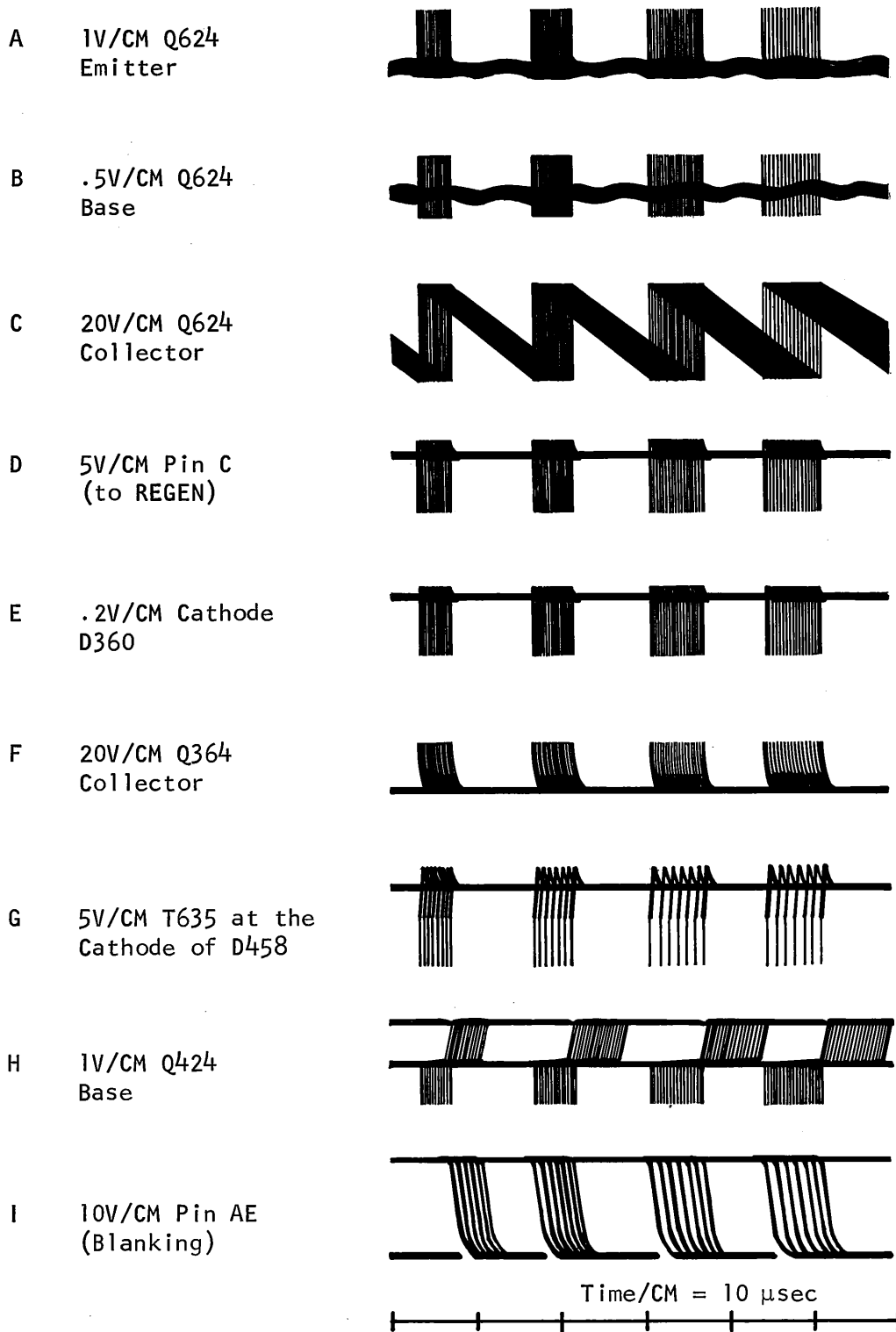

REAL TIME CLOCK and associated circuits in Random  
fig 3-24



5T3 TRAINING CALIBRATION PROCEDURE  
(Long Form)

The following calibration procedure is a step-by-step training device. Specifications used are customer performance requirements. Each instrument must meet or exceed these specifications.

Equipment Required

1. Type 661 main-frame oscilloscope (calibrated)
2. Type 4S1 DUAL-TRACE sampling vertical plug-in.
3. Type 4S2 DUAL-TRACE sampling vertical plug-in.
4. Test oscilloscope - 545B with 1A1 or equivalent.
  - a) X1 probe - P6027
  - b) X10 probe - P6006
5. Type 180A time mark generator.
  - a) BNC cable
  - b) GR to BNC female adaptor (017-063)
6. Type 111 pulse generator
  - a) Type 111 variable Atten (067-511)
  - b) GR 50 $\Omega$  cables
  - c) GR Attenuators (X5 or X10)
  - d) GR "T" connector
7. GR oscillator 1218-A (900 mc to 2 Gc)
  - a) Mixer rectifier
  - b) GR 50 $\Omega$  cables
  - c) GR to Male BNC Adaptor (017-064)
  - d) GR "T" connector
8. GR oscillator 1209-B (250 mc to 920 mc)
  - a) GR 50 $\Omega$  cables
  - b) Various 50 $\Omega$  GR Atten.
  - c) GR "T" connector

Equipment Required (Con't)

9. Polorad Model 1107 generator  
3.8 Gc - 8.2 Gc
  - a) 3 - X2 Atten (017-046)
  - b) 1 - X10 Atten (017-044)
  - c) 1 - GR "T" connector
  - d) 2 - 2 nSEC GR 50 $\Omega$  cables
  - e) GR to Type N Male connector (017-021)
10. BNC 50 $\Omega$  Terminator (011-049)
11. GR 50 $\Omega$  Terminator (017-047)
12. Multimeter (optional)
13. Adjusting tools
  - a) screwdriver
  - b) coil tweaker
14. Power cords

## OUTLINE OF ADJUSTMENTS &amp; CHECKS

	<u>Page No.</u>
I. TRIGGER INPUT DC Adjustments	4-10
A. 50 $\Omega$ DC LEVEL ZERO Adj. (R83)	4-10
Adjust for zero volts at J80.	
B. 1 MEG LEVEL ZERO Adj. (R10)	4-11
Adjust for zero volts at J80.	
II. TRIGGER Adjustments	4-12
A. DC LEVEL ZERO (R103)	4-12
Adjust for zero volts at emitter of Q124.	
B. OUTPUT TD BIAS Adj. (R210)	4-13
Adjust just short (1/8 turn) of free running.	
C. TRIG LEVEL ZERO Adj. (R120)	4-14
Adjust for proper operation of TRIG LEVEL control.	
D. STABILITY ZERO Adj. (R172)	4-18
Adjust until 5T3 free runs with slight CW rotation of STABILITY control.	
III. SWEEP DC - REAL TIME Adj. and Check	4-20
A. STAIRCASE ZERO Adj. (R585)	4-20
Adjust for zero volts at the output of the horizontal sweep generator.	
B. SWEEP LENGTH (R612)	4-22
Adjust for 10.5 cm of sweep.	
C. REAL TIME SWEEP CAL Adj. (R515)	4-22
Tol. $\pm 3\%$ .	
D. REAL TIME Sweep Accuracy Check.	4-23
Check real timing from .2 mSEC to 5 SEC. Tol. $\pm 3\%$	

	<u>Page No.</u>
E. REAL TIME VARIABLE Range Check $\geq 2.5:1$ range.	4-24
F. 100 kc Clock Adj. (L625) Adjust oscillator for 100 kc $\pm 1\%$ .	4-24
G. SAMPLING RATE RANDOM Check $>10 \mu s$ and $\leq 15 \mu s$ modulated by 60 cps.	4-26
IV. FAST RAMP-INVERTER Adj. and Checks	4-27
A. INVERTER DC LEVEL Adj. (R376) Adjust for zero volts at input to inverter ramp.	4-27
B. TIMING CURRENT Adj. (R340) Equivalent timing accuracy $\pm 3\%$ .	4-29
C. EQUIVALENT TIME/CM VARIABLE RANGE Check $\geq 2.5:1$	4-30
D. EQUIVALENT TIME Sweep Accuracy Check 20 nSEC/CM to 100 $\mu$ SEC/cm $\pm 3\%$ .	4-30
E. Single Display Check	4-30
F. COMP LEVEL (R345) - TIME POSITION ZERO Adj. (R340) Adjust for minimum separation and distortion at beginning of sweep.	4-31
G. 1 nSEC TIMING Adj. (C343)	4-34
H. 10 nSEC TIMING Adj. (C350H) Tol. $\pm 3\%$ .	4-37
I. TIME POSITION RANGE - Linearity Check	4-38
J. SWEEP MAGNIFIER Accuracy Check Tol. $\pm 3\%$ .	4-39

	<u>Page No.</u>
V. DOTS/CM Adjustments	4-40
A. DOTS CAL (R415)	4-40
Adjust for 5 DOTS/CM $\pm 3\%$ .	
B. 10 DOTS CAL. (C560G)	4-41
Adjust for 10 DOTS/CM $\pm 3\%$ .	
C. 20 DOTS CAL (C560E)	4-41
Adjust for 20 DOTS/CM $\pm 3\%$	
D. 50 DOTS CAL (C560C)	4-42
Adjust for 50 DOTS/CM $\pm 3\%$ .	
E. 100 DOTS CAL (C560B)	4-42
Adjust for 100 DOTS/CM $\pm 3\%$ .	
F. 1000 DOTS/CM and TIMED Position Check	4-43
VI. TRIGGERING Checks	4-44
A. EQUIVALENT TIME Jitter Check (500 mc)	4-44
1) $\leq 70$ pSEC of jitter for a 400 mv signal at 500 mc applied to the 4S1 with internal triggering.	
2) $\leq 70$ pSEC of jitter for a 50 mv signal at 500 mc applied to the 50 $\Omega$ external input - DC coupled.	
3) $\leq 300$ pSEC of jitter for a 5 mv signal at 500 mc applied to the 50 $\Omega$ external input - DC coupled.	
4) $\leq 300$ pSEC of Jitter for a 40 mv signal at 500 mc applied to the 4S1 with internal triggering.	



Page No.

- B. EQUIVALENT TIME PULSE  
Triggering Check. 4-47
- Pulse shape 2 nSEC wide,  
1 nSEC or less risetime,  
 $\leq$  100 kc repetition rate.
- 1)  $\leq$  30 pSEC of jitter for  
a 400 mv. Pulse signal  
applied to the 4S1 with  
internal triggering.
  - 2)  $\leq$  30 pSEC of jitter for  
a 50 mv pulse applied to  
the EXT TRIG (50 $\Omega$ ) input  
DC coupled.
  - 3)  $\leq$  300 pSEC of jitter for  
a 40 mv pulse applied to  
the 4S1 with internal  
triggering.
  - 4)  $\leq$  300 pSEC of jitter for  
a 5 mv pulse signal  
applied to the EXT TRIG  
(50 $\Omega$ ) input, DC coupled.
- C. 100 nSEC TIME-POSITION Range  
jitter Check 4-50
- $\leq$  40 pSEC of jitter, internal  
triggering, 400 mv pulse  
signal.
- D. TIME POSITION Range Jitter  
Check. 4-50
- 1) 1  $\mu$ SEC TIME POSITION,  
 $\leq$  400 pSEC of jitter.
  - 2) 10  $\mu$ SEC TIME POSITION,  
 $\leq$  4 nSEC of jitter.
  - 3) 100  $\mu$ SEC TIME POSITION,  
 $\leq$  40 nSEC of jitter.
  - 4) 1 mSEC TIME POSITION,  
 $\leq$  400 nSEC of jitter.

## E. External UHF SYNC MODE Check

4-51

- 1)  $\leq 70$  pSEC of jitter for a 2 Gc signal externally triggered with 5 mv.
- 2)  $\leq 30$  pSEC of jitter for a 2 Gc signal externally triggered with 10 mv.
- 3)  $\leq 70$  pSEC of jitter for a 5 Gc signal externally triggered with 10 mv.
- 4)  $\leq 30$  pSEC of jitter for a 5 Gc signal externally triggered with 50 mv.

Insert the 5T3 and the 4S1 plug-ins into the Type 661 instrument.  
Remove the right side panel of the 661.

Apply power to the sampling equipment and allow a few minutes for warm-up. Apply power to the test oscilloscope and allow a few minutes for warm-up.

Preset the following front panel controls.

5T3

SAMPLES/CM	100
TIME POSITION	midrange
EQUIVALENT TIME/CM	10 nSEC
MAGNIFIER	X1
EQUIVALENT TIME/CM VARIABLE	CAL.
TRIG LEVEL	CCW
STABILITY or UHF SYNC	CCW
TRIG SOURCE	CAL.
SLOPE	+
EXT TRIG MODE	50 $\Omega$ DC
REAL TIME/CM	2 mSEC
SAMPLING RATE	100 kc
SWEEP MODE	NORM

4S1

MODE	A ONLY
TRIGGERING	A
COUPLING	DC
CH 1 - CH 2	
VERT Position	midrange
MILLIVOLTS/CM	200
VARIABLE	CALIBRATED
DC OFFSET	midrange
DISPLAY	NORMAL
SMOOTHING	NORMAL

661

HORIZONTAL DISPLAY

HORIZ POSITION

AMPLITUDE/TIME CALIBRATOR

mV AMPLITUDE

$\mu$ SEC/CYCLE

FOCUS

INTENSITY

ASTIGMATISM

X1

midrange

1000

OFF

midrange

Figure 4-1 illustrates the preset positions.

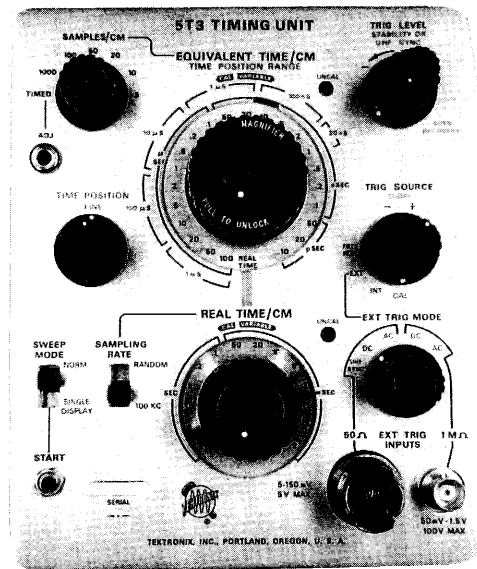
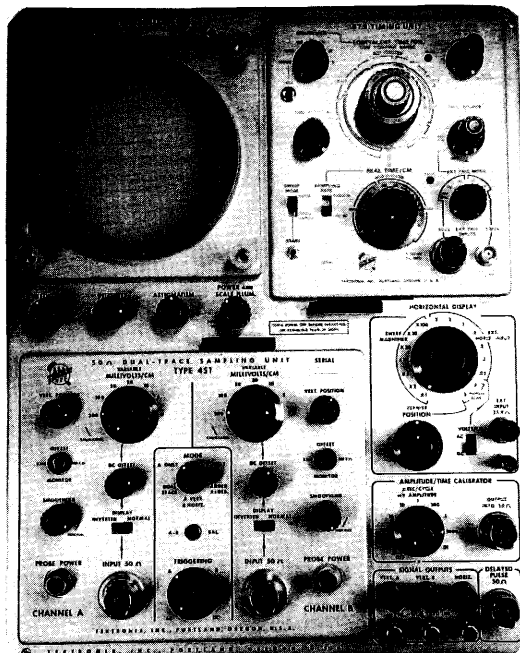

Figure 4-1

## I. TRIGGER INPUT DC Adjustments

### A. $50\Omega$ DC LEVEL ZERO Adj. (R83)

1. Insert a GR  $50\Omega$  terminator into the  $50\Omega$  EXT. TRIG INPUTS Connector.
2. Connect an Oscilloscope (using a X1 probe) to the junction of C65-R80 (J80 connector), see figure 4-2.

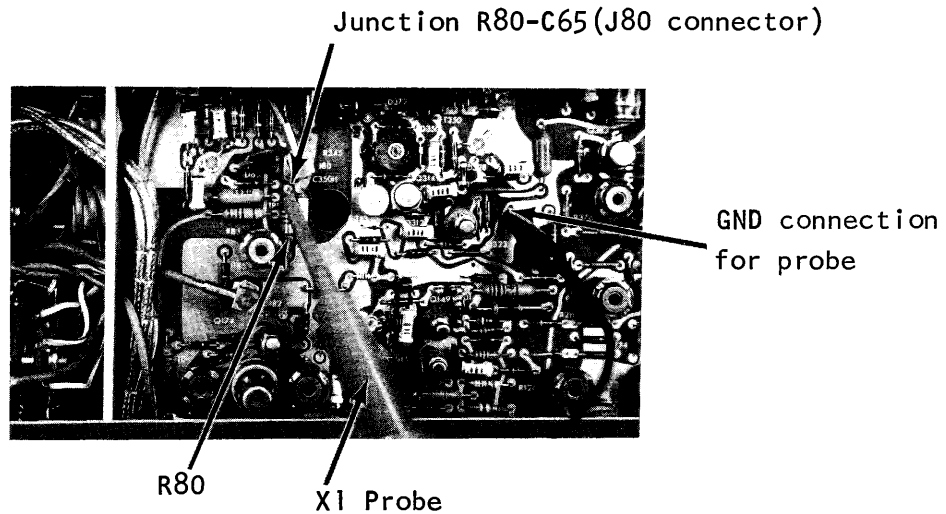
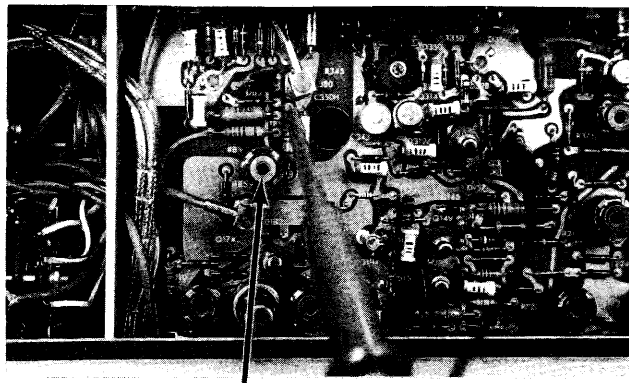

Figure 4-2

3. Adjust  $50\Omega$  DC LEVEL ZERO, (R83 - see figure 4-3) for zero volts as read on the oscilloscope.



R83  
 $50\Omega$  DC LEVEL ZERO Adj.

Figure 4-3

**B. 1 MEG LEVEL ZERO Adj. (R10)**

1. Set the EXT TRIG MODE control to the 1 MEG DC position.
2. Insert a BNC  $50\Omega$  terminator into the 1 M $\Omega$  connector.
3. With the oscilloscope connected to the junction of R80-C65. Adjust 1 MEG LEVEL ZERO (R10-see figure 4-4) for zero volts.
4. Disconnect the voltmeter and the two  $50\Omega$  attenuators on the front panel.

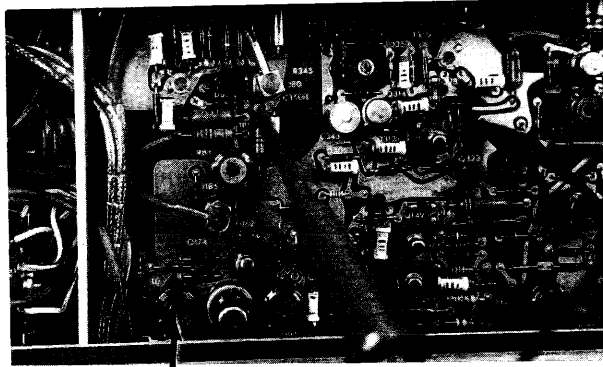

R10  
1 MEG LEVEL ZERO Adj.

Figure 4-4

## II. TRIGGER Adjustments

### A. DC LEVEL ZERO (R103)

1. Check the following front panel controls for correct positions. Very important for this and the following steps.

TRIG LEVEL	Centered
STABILITY	CCW
SLOPE	+

2. Preset TRIG LEVEL ZERO adj. (R120 - see figure 4-5) fully CCW position.

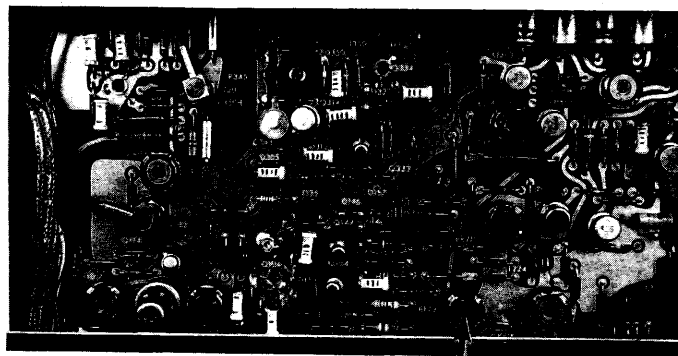

R120  
TRIG LEVEL ZERO

Figure 4-5

3. With an oscilloscope, set the emitter of Q124 to zero (0) volts by adjusting DC LEVEL ZERO Adj. (R103 - see figure 4-6).

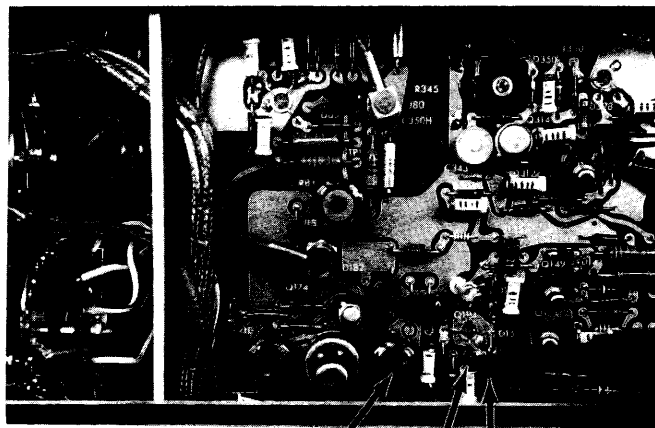

Emitter Q124  
DC LEVEL ZERO Adj.  
R103

Figure 4-6

4. Disconnect the oscilloscope.

### B. OUTPUT TD BIAS Adjustment (R210)

1. Preset front panel TRIG LEVEL control fully CCW.
2. Preset STABILTY ZERO Adj. (R172 - see figure 4-7) CCW.
3. Preset OUTPUT TD BIAS control (R210 - see figure 4-7) CW (free running).
4. To determine when the 5T3 is properly triggered, connect a X10 probe from the test scope to the junction of R204, R198 and R193, see figure 4-7. Leave the test probe connected for the following triggering adjustments.
5. Set test scope time/cm to 5  $\mu$ sec and the vertical sensitivity to display approximately 4 cm of signal. Adjust test scope triggering controls for a stable display. See figure 4-7.

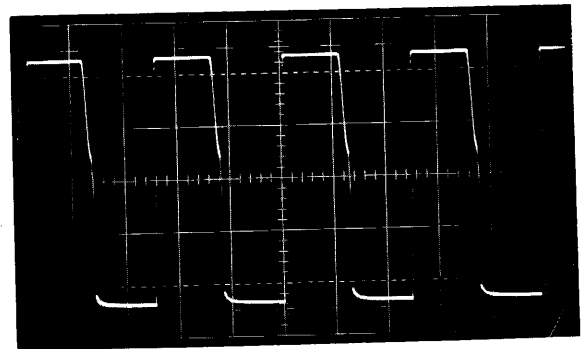
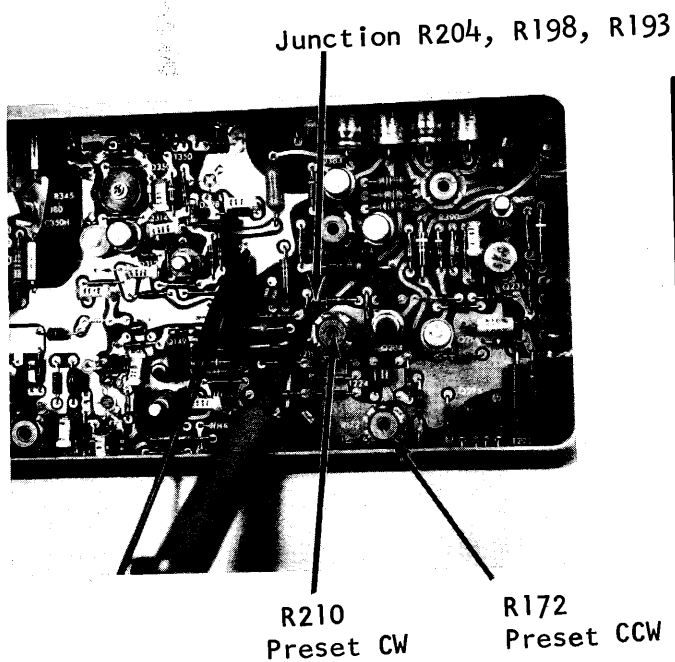

Test Scope Display  
 5  $\mu$ SEC/cm  
 .2 volts/cm (with probe)

Figure 4-7



6. Adjust the OUTPUT TD BIAS Adj. (R210 - see figure 4-8) to a point just short of free running (trace disappears from test scope CRT) plus another few degrees additional rotation.

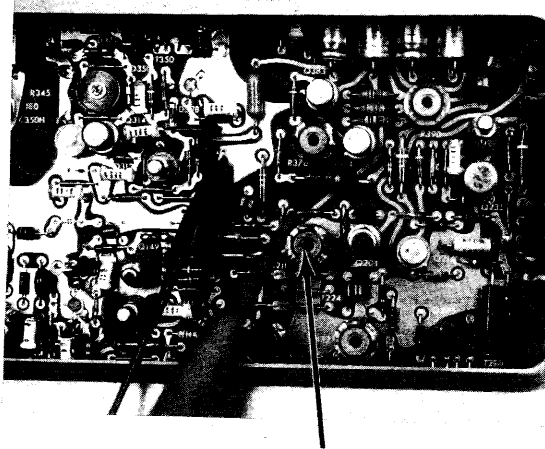

R210  
OUTPUT TD BIAS Adj.

Figure 4-8

- C. TRIG LEVEL ZERO Adjustment (R120)
  1. Preset STABILITY ZERO (R172 - refer to figure 4-7) full clockwise (CW) and then back off approximately 30°.
  2. Set the STABILITY control (front panel) full CW to the AUTO RECOVERY position (switch position).
  3. Preset the TRIG LEVEL control to center or midrange - see figure 4-9.

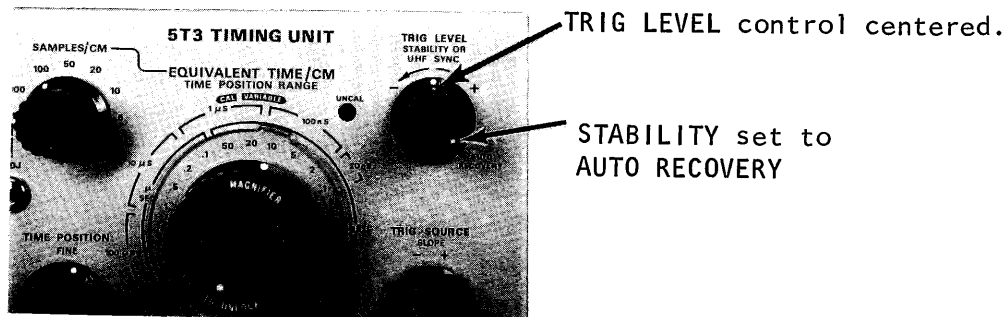
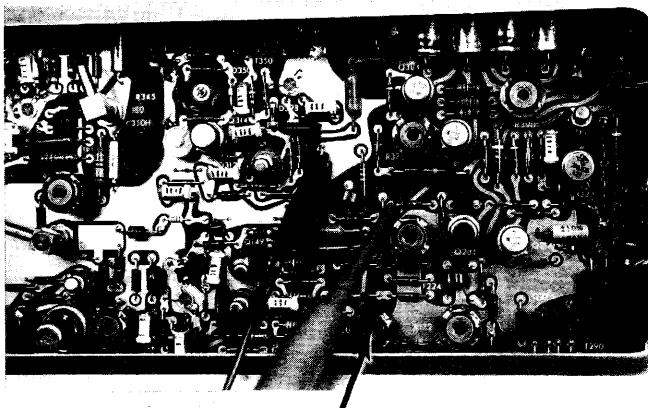

Figure 4-9

4. Adjust the TRIG LEVEL ZERO (R120 - see figure 4-10A) until a slight (few degrees) rotation of the front panel TRIG LEVEL control away from center toward CCW (minus) position will cause free running (figure 4-10C).



R120  
TRIG LEVEL ZERO Adj.

(A)

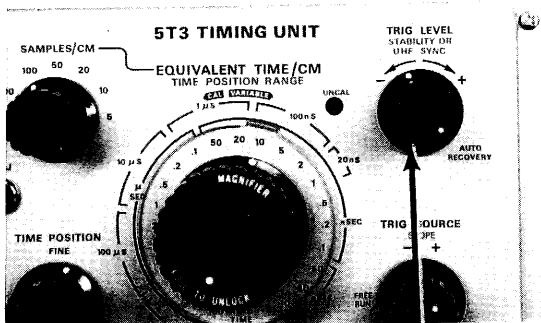

(B)

TRIG LEVEL control slightly CCW should free run 5T3.

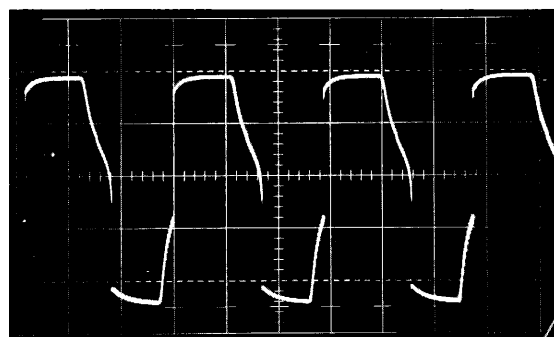

STABLE OPERATION  
(Test scope display)  
(C)

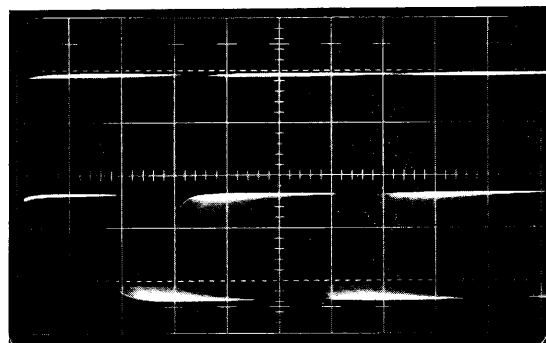

UNSTABLE OPERATION as indicated by the test scope display, even with a trace being displayed on the 661.  
(D)

5. Set the SLOPE switch to - (minus) position.
6. A slight rotation of the TRIG LEVEL control away from center toward CW (plus) position should cause the circuit to free run as monitored on the test scope (see figure 4-11). Slight adjustment of TRIG LEVEL ZERO may be required.

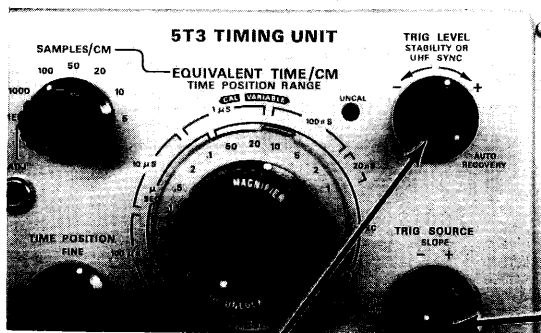

SLOPE  
to -

TRIG LEVEL slightly CW should  
free run 5T3.

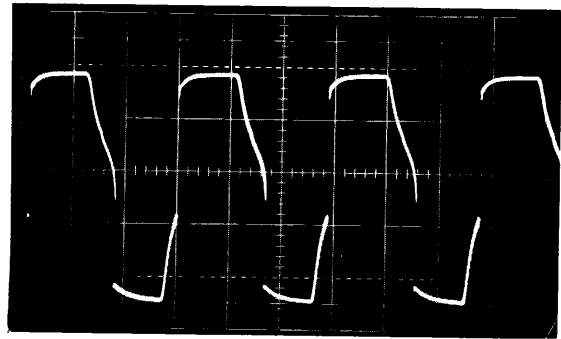

Test scope display

Figure 4-11

7. By setting the SLOPE switch from + to -, turn the TRIG LEVEL control small amount away from center toward MINUS (SLOPE in+) or plus (SLOPE in -) and readjust TRIG LEVEL ZERO for the smallest amount of dead zone about mechanical center (see figure 4-12). (The TRIG LEVEL control knob may have to be relocated in case the dead zone does not fall near the mechanical center.)

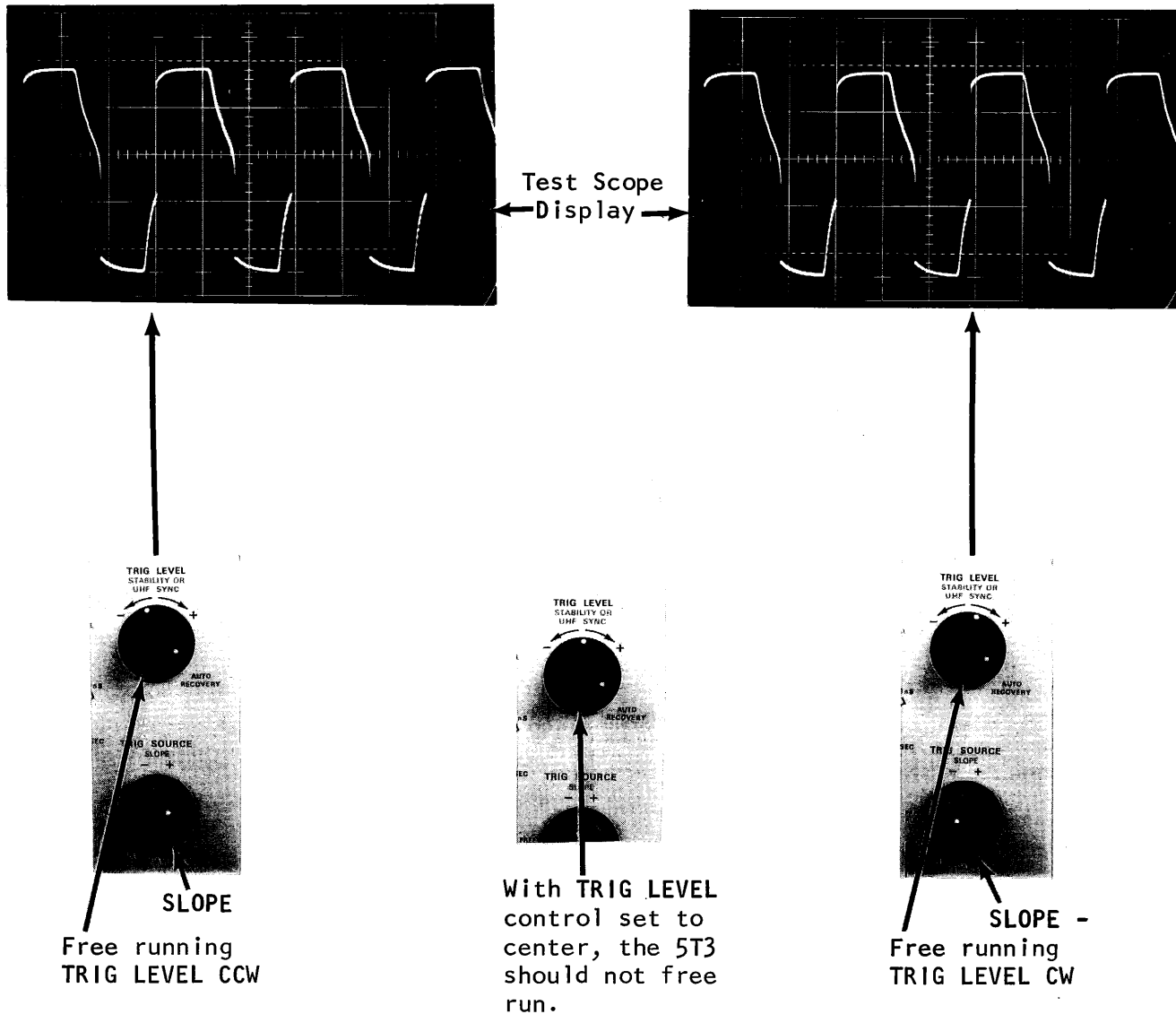

Figure 4-12

\*The adjustment of R120 to obtain a dead zone near the center or midrange of TRIG LEVEL control is desired. There is just one problem, this dead zone will vary about  $\pm 30^\circ$  from the 12 o'clock position as the temperature varies  $\pm 25^\circ\text{C}$ . This movement of the dead zone is normal and should not cause erratic triggering. At normal room temperature, the dead zone should be near 12 o'clock.

## D. STABILITY ZERO Adjustment (R172)

1. Set the SLOPE switch to the + (plus) position.
2. Set the TRIG LEVEL control to the free run position (slight rotation CCW from center). Do NOT readjust the TRIG LEVEL control for the remainder of the adjustment.
3. Set the STABILITY control to 12 o'clock position, see figure 4-13.

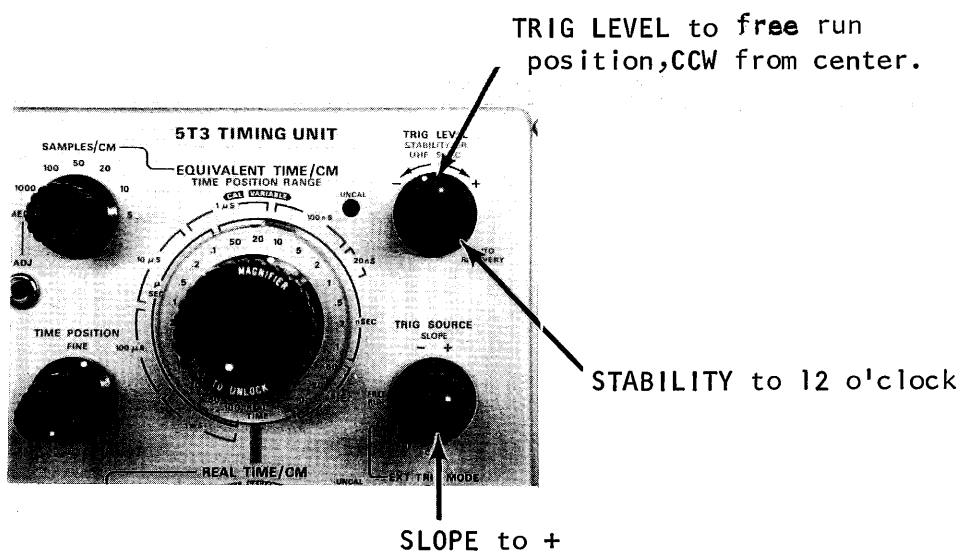
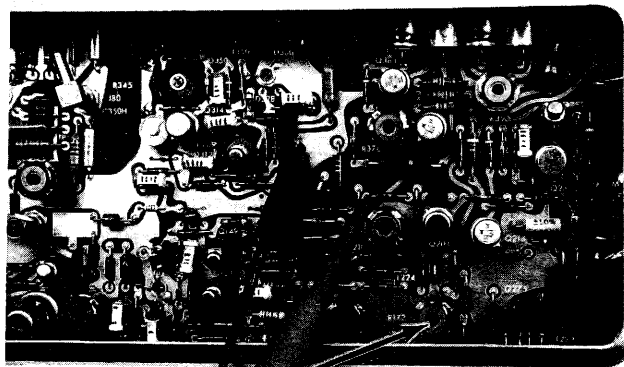

Figure 4-13

4. Adjust the STABILITY ZERO (R172 - see figure 4-12A) until the 5T3 free runs with a slight CW rotation of the STABILITY control and stops free running with a slight CCW rotation of the STABILITY (see figure 4-14B).



R172  
STABILITY ZERO Adjustment

(A)

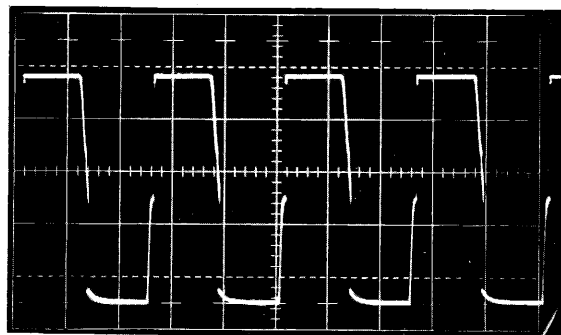

(Test scope display)  
When R172 is adjusted a slight rotation CW of the STABILITY control should free run the instrument.

(B)

Figure 4-14

5. Recheck step C because there is some interaction between the TRIG LEVEL ZERO Adj. (R120) and STABILITY ZERO Adj. (R172).
6. Disconnect the X10 probe.

### III. SWEEP DC Adjustment - REAL TIME Adjustments and Checks

Preset the following front panel controls.

EQUIVALENT TIME/CM	2 $\mu$ SEC/cm
SAMPLES/CM	100
REAL TIME/CM	1 mSEC
TRIG SOURCE	FREE RUN
SWEEP MODE	SINGLE DISPLAY

#### A. STAIRCASE ZERO Adjustment (R585)

1. A test scope and X1 probe should be used for setting the the output of the Horizontal Sweep Generator to zero volts.
2. Connect the X1 probe to the output of the sweep generator (the easiest connecting point is one end of the EQUIV. TIME/CM VARIABLE control, R650). See figure 4-15.

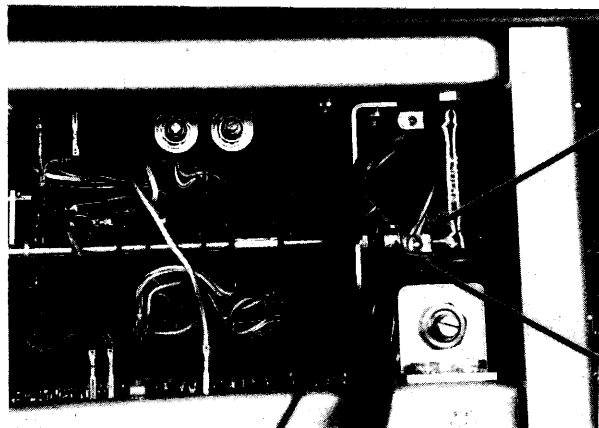

EQUIVALENT TIME/CM  
VARIABLE, R650

SWEEP INPUT from  
661 (HORIZ. SWEEP GEN.  
output).

Figure 4-15

3. Establish a DC zero voltage reference point on the test oscilloscope.
4. Adjust STAIRCASE ZERO Adj. (R585 - see figure 4-16) for zero volts.

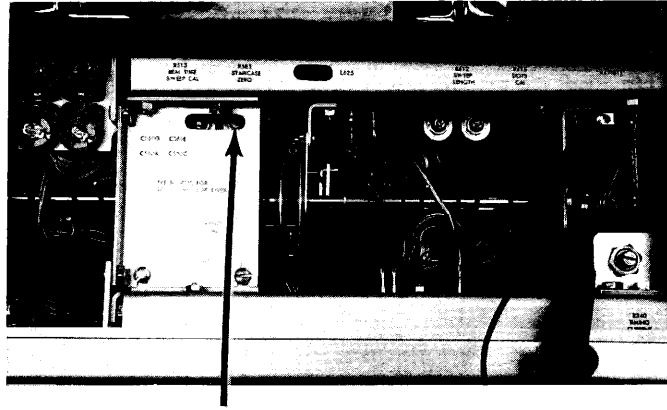

R585  
STAIRCASE ZERO Adj.

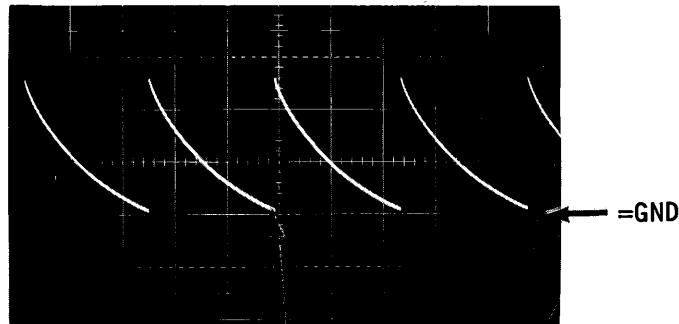

Adj. R585 for zero volts

Figure 4-16



### B. SWEEP LENGTH Adjustment (R612)

1. Set the SWEEP MODE control to NORM.
2. Adjust the SWEEP LENGTH Adj. (R612 - see figure 4-17) for 10.5 cm of sweep on the 661 CRT screen.
3. With the test scope connected as in step A previously (output of Sweep Generator), check that the staircase amplitude is approximate 52.5 volts.

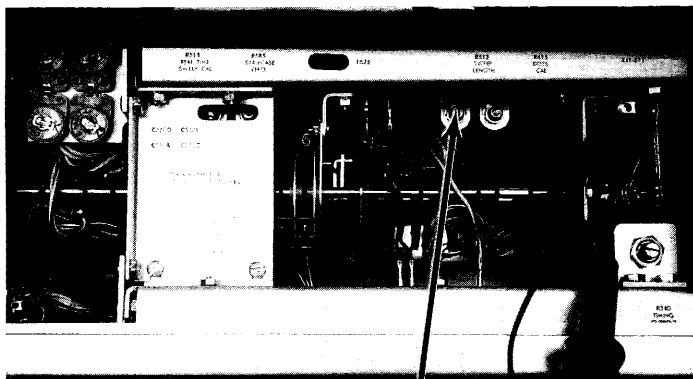

R612  
SWEEP LENGTH Adj.  
Adjust for 10.5 cm of  
sweep.

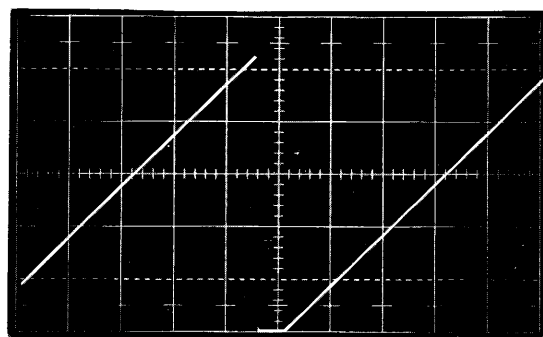

Test scope display  
(10 v/cm sensitivity)  
≈ 52.5 volts

Figure 4-17

4. Disconnect the X10 test scope probe.

### C. REAL TIME SWEEP CAL Adjustment (R515)

1. Apply from the Type 180A time mark generator  $\approx 1$  volt p-p 1 mSEC markers to CH A Input of the 4S1.
2. Set the EQUIVALENT TIME/CM to REAL TIME (REAL TIME/CM set to 1 mSEC).
3. Set the 5T3 TRIG SOURCE control to INT and adjust TRIG LEVEL and STABILITY controls for a stable display.

4. Adjust REAL TIME SWEEP CAL Adj. (R515 - see figure 4-18A) for 1 (one) time marker/cm  $\pm 3\%$  (see figure 4-18B).

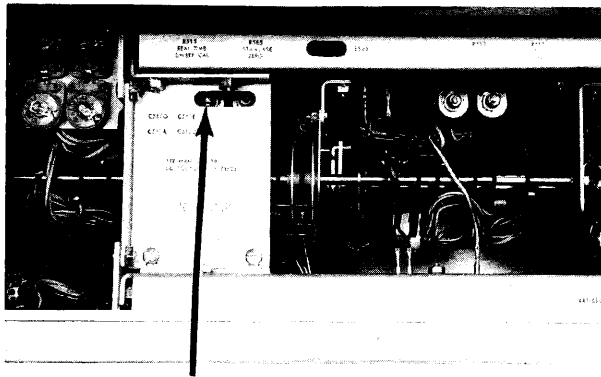

R515 - REAL TIME SWEEP CAL Adj.  
(A)

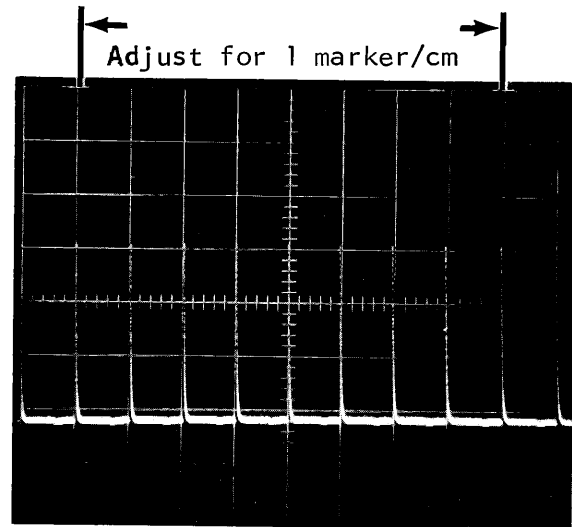

(B)

Figure 4-18

D. REAL TIME SWEEP ACCURACY Check

1. Using the following table. Check each position of the REAL TIME/CM control for correct timing accuracy.

<u>REAL TIME/CM</u>	<u>180A</u>	<u>MARKERS/CM</u>	<u>ACCURACY</u>
* .2 mSEC	100 $\mu$ SEC	2	2.4 mm $\pm 3\%$
.5 mSEC	500 $\mu$ SEC	1	"
** 1 mSEC	1 mSEC	1	"
2 mSEC	1 mSEC	2	"
5 mSEC	5 mSEC	1	"
10 mSEC	10 mSEC	1	"
20 mSEC	10 mSEC	2	"
50 mSEC	50 mSEC	1	"
.1 SEC	100 mSEC	1	"
.2 SEC	100 mSEC	2	"
.5 SEC	500 mSEC	1	"
1 SEC	1 SEC	1	"
2 SEC	1 SEC	2	"
5 SEC	5 SEC	1	"

\* To obtain a display with 100  $\mu$ SEC markers applied, set the SAMPLING rate to RANDOM. Reset the SAMPLING rate to 100 kc for the remainder of the switch position.

\*\* Adjusted previously.

E. REAL TIME VARIABLE Range Check ( $\geq 2.5:1$  range)

1. Set the REAL TIME/CM switch to the 1 mSEC position.
2. With 1 mSEC markers applied from the type 180A, Rotate the REAL TIME VARIABLE fully CW (UNCAL position). The distance between successive time marks must be  $\geq 2.5$  divisions. The uncalibrated light must go on when the REAL TIME/CM VARIABLE control is switched out of its CCW position. See figure 4-19.

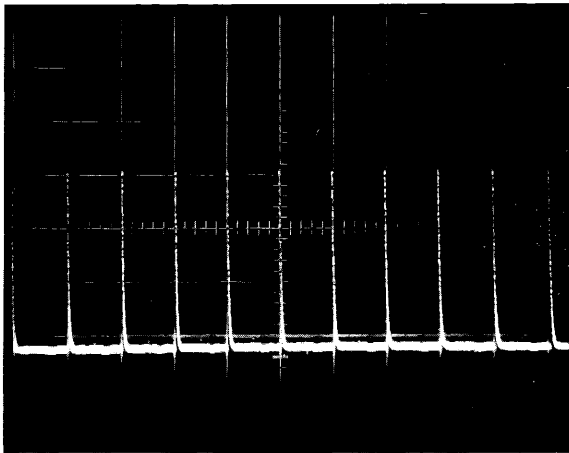

REAL TIME/CM VARIABLE CCW

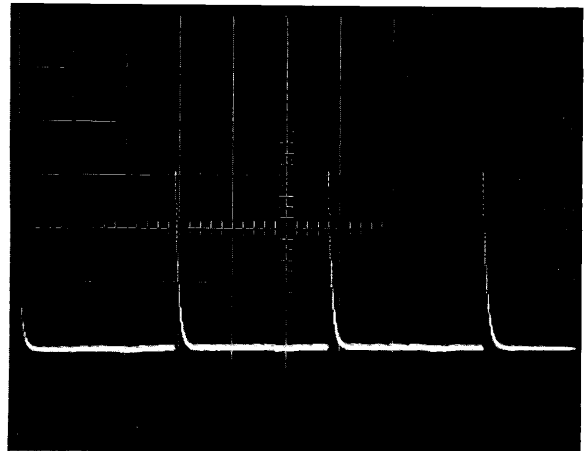

REAL TIME/CM VARIABLE CW  
( $\geq 2.5:1$  range)

Figure 4-19

3. Return the VARIABLE TIME/CM control to the calibrated position (fully CCW).

F. 100 kc Clock Adjustment (L625)

The 100 kc oscillator is adjusted to 100 kc ( $10 \mu\text{SEC}$ )  $\pm 1\%$ .

1. Apply  $10 \mu\text{sec}$  markers from the Type 180A to the 4S1 input.
2. Set the EQUIVALENT TIME/CM to  $10 \mu\text{sec}$  and adjust triggering controls for a stable display.
3. Reset the EQUIVALENT TIME/CM to REAL TIME and the REAL TIME/CM to  $.2 \text{ mSEC}$ .
4. Recheck SAMPLING RATE switch to be sure that it is set to 100 kc.

5. The display on the 661 CRT will be the beat frequency between the 10  $\mu$ SEC markers and the 100 kc oscillator in the 5T3.

NOTE: The 5T3 100 kc oscillator is adjusted to 100 kc  $\pm 1\%$ . A 1% specification indicates a beat frequency of  $\leq 1$  kc (1 mSEC). Therefore, the time between beat pulses should be 1 mSEC or greater. It should not be difficult to obtain a beat frequency of .1 SEC or even 1 SEC.

6. Adjust L625 for a "straight" line on the CRT. See figure 4-20.

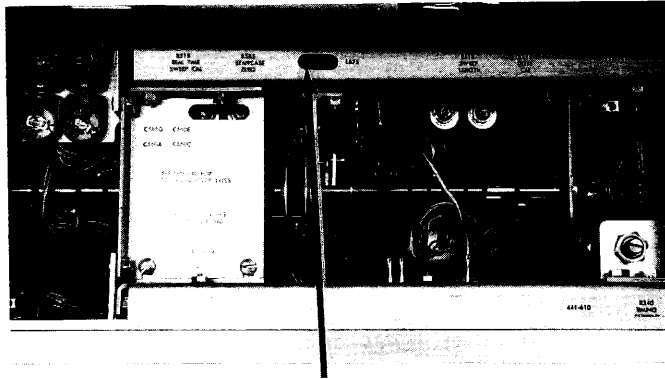

L625

Figure 4-20

NOTE: If the frequency of the 100 kc oscillator is misadjusted by a wide margin, it may be difficult to adjust for a straight line. In this case, connect the test scope X10 probe to the collector of Q630 - Real time clock blocking oscillator (see figure 4-21). (The easiest place to connect the probe is pin C of the HORIZ SWEEP printed circuit board) and adjust L625 for 100 kc as read on the test scope. Then, adjust for the "straight" line on the 661 CRT display.

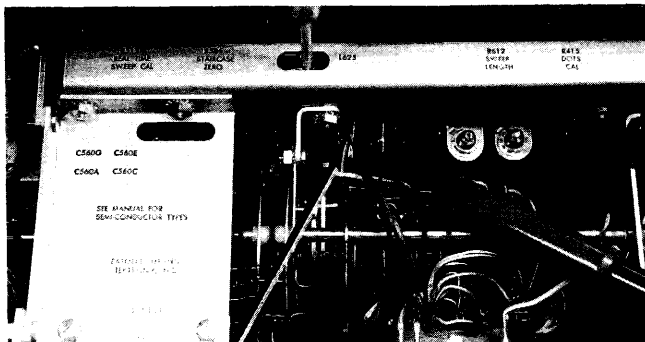

Pin C - HORIZ SWEEP Board

Test scope display  
TIME/CM - 10  $\mu$ SEC

Figure 4-21

7. The Beat frequency can be measured by setting the REAL TIME/CM control to a slower sweep rate and measure the time between pulses. See figure 4-22.

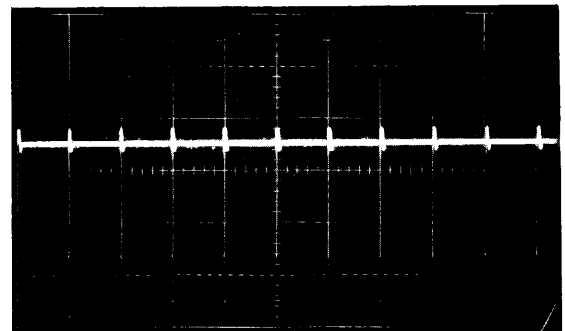
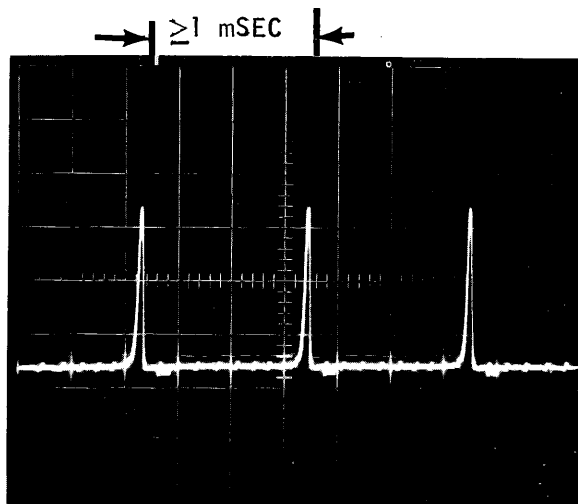
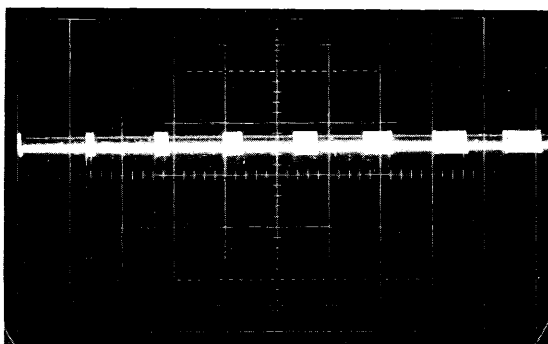

Figure 4-22

G. SAMPLING RATE RANDOM Check.

1. Using the same set-up as in step F, set the SAMPLING RATE switch to RANDOM.
2. The sampling rate as measured on the test scope should be  $>10 \mu\text{s}$  and  $\leq 15 \mu\text{s}$ . The sampling rate should be modulated by 60 cps. See figure 4-23.



Test scope display  
TIME/CM -  $10 \mu\text{SEC}$

Figure 4-23

3. Disconnect the X10 test probe.

## IV. FAST RAMP-INVERTER Adjustments and Checks

## A. INVERTER DC LEVEL Adjustment (R376)

1. Preset the following front panel controls.

EQUIVALENT TIME/CM	20 nSEC
TRIG SOURCE	FREE RUN
SWEEP MODE	SINGLE DISPLAY
TIME POSITION (Black knob)	Full CW
TIME POSITION FINE (Red)	Full CW

2. Connect a X1 probe from the test scope to the input of Inverter Amplifier (Junction R381, R383 and R385). The easiest place to connect the probe is terminal H of the fast Ramp Board. See figure 4-24.

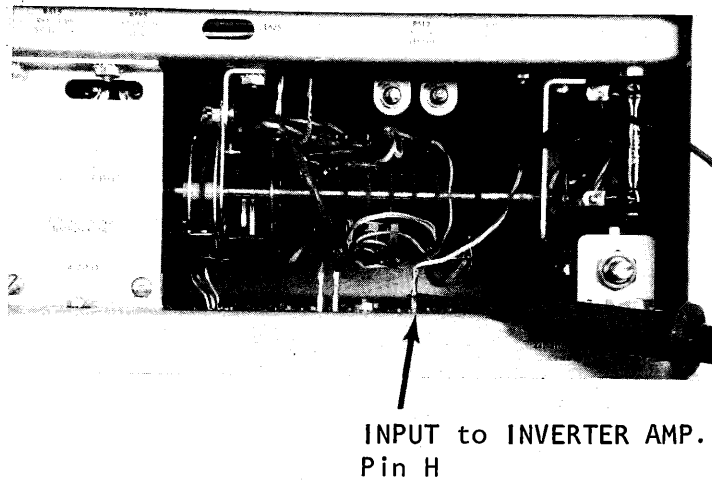
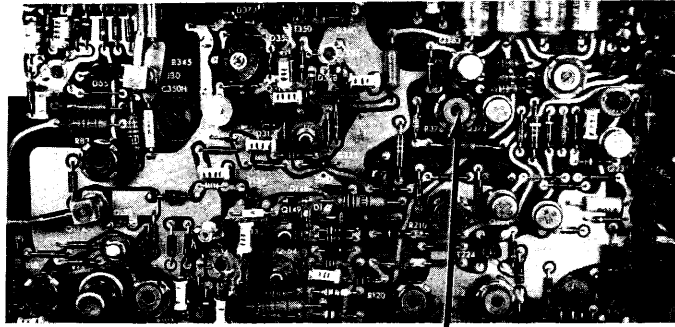

Figure 4-24

3. Adjust INVERTER DC LEVEL Adj. (R376 - see figure 4-25A) for zero volts as viewed on the test scope (see figure 4-25B).

NOTE: The TIME POSITION ZERO adjust, R390, normally would not require presetting before making the above adjustment unless it was inadvertently "tweaked". In which case it should be set to midrange.



R376  
INVERTER DC LEVEL Adj.

(A)

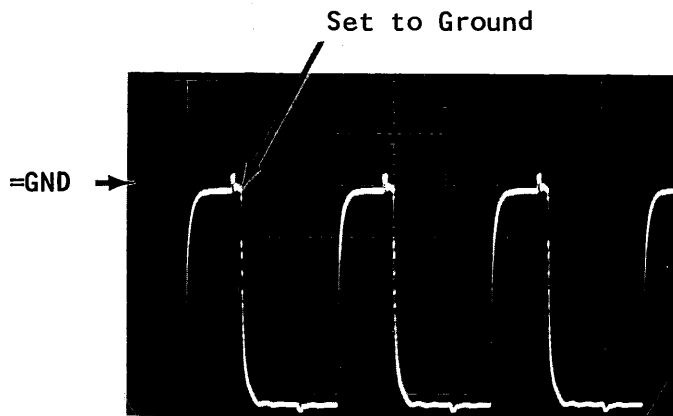

Test Scope display

(B)

Figure 4-25

4. Disconnect the X1 test probe.
5. Set the SWEEP MODE switch to NORMAL.

**B. TIMING CURRENT Adjustment (R340)**

1. Set the EQUIVALENT TIME/CM to 1  $\mu$ SEC.
2. Apply from the Type 180A, 1  $\mu$ SEC markers to the input of the 4S1.
3. Adjust the TRIG LEVEL and STABILITY controls for a stable display. (If you are unable to obtain a display on the 661 CRT. The COMP LEVEL adjustment, R345, may be misadjusted. The COMP LEVEL Adj. should be set as far CW as possible and still obtain a stable display.)
4. Preset the TIME POSITION control (Black knob) to midrange.
5. Adjust TIMING current Adj. (R340 - see figure 4-26) for 1 marker/cm.

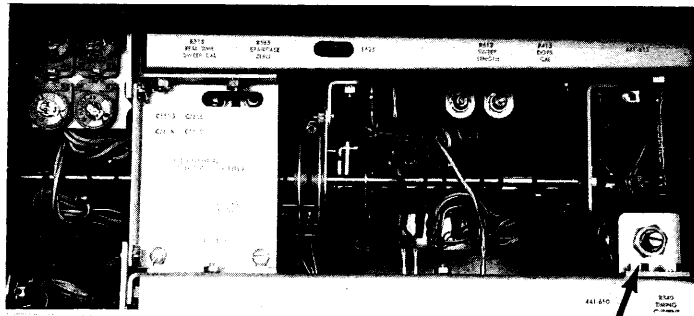

R340  
TIMING Current

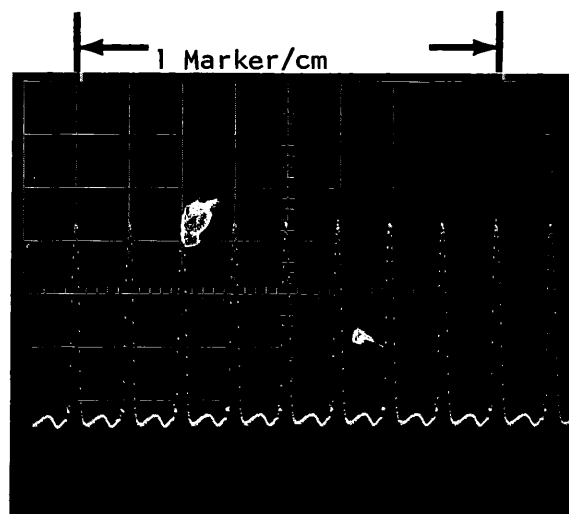

Figure 4-26



C. EQUIVALENT TIME/CM VARIABLE RANGE Check ( $\geq 2.5:1$ )

1. With 1  $\mu$ SEC marker displayed on the 661 CRT as per step B. Check the range of the VARIABLE TIME/CM for at least 2.5:1. Set the VARIABLE full CW. The distance between successive 1  $\mu$ sec time marks must be  $\geq 2.5$  divisions. The uncalibrated light must go on when the EQUIVALENT TIME/CM VARIABLE control is switched out of its CCW position.

D. EQUIVALENT TIME/CM SWEEP Accuracy Check

1. Using the following table, check the sweep ranges listed for correct timing accuracy.

<u>EQUIVALENT TIME/CM</u>	<u>180A</u>	<u>MARKERS OR CYCLES/CM</u>	<u>ACCURACY</u>
20 nSEC	50 mc	1 cycle/cm	2.4 mm $\pm 3\%$
50 nSEC	10 mc	1 cycle/2 cm	"
.1 $\mu$ SEC	10 mc	1 cycle/cm	"
.2 $\mu$ SEC	5 mc	1 cycle/cm	"
.5 $\mu$ SEC	1 $\mu$ SEC	1 marker/2 cm	"
*1 $\mu$ SEC	1 $\mu$ SEC	1 marker/cm	"
2 $\mu$ SEC	1 $\mu$ SEC	2 marker/cm	"
5 $\mu$ SEC	5 $\mu$ SEC	1 marker/cm	"
10 $\mu$ SEC	10 $\mu$ SEC	1 marker/cm	"
20 $\mu$ SEC	10 $\mu$ SEC	1 marker/cm	"
50 $\mu$ SEC	50 $\mu$ SEC	1 marker/cm	"
100 $\mu$ SEC	100 $\mu$ SEC	1 marker/cm	"

\*Adjusted previously

E. Single Display Check

1. With the Type 180A connected to the input of the 4S1, set the EQUIVALENT TIME/CM to 1  $\mu$ SEC.
2. Apply from the 180A, 1  $\mu$ s markers. Adjust the triggering controls for a stable display.
3. Set the SWEEP MODE switch to SINGLE DISPLAY. The signal will disappear.
4. Press the START button. A single triggered sweep will occur.
5. Disconnect the Type 180A markers press START button. The sweep will remain off. Apply the 1  $\mu$ SEC markers and a single triggered sweep will occur.
6. Set the SWEEP MODE switch to NORM.
7. Disconnect the Type 180A time-mark generator.

F. COMP LEVEL - TIME POSITION ZERO Adjustment

1. Preset the following front panel controls.

5T3

EQUIVALENT TIME/CM	2 $\mu$ SEC
TIME POSITION (Black knob)	Full CW
TIME POSITION FINE (Red knob)	Full CW

\* Important that these two controls are preset to full CW.

SAMPLES/CM	50
------------	----

661 Controls

AMPLITUDE/ TIME Calibrator

$\mu$ SEC/CM	10
mV AMPLITUDE	1000

2. Connect the 661 CALIBRATOR output to the 4S1 input jack.
3. Adjust the TRIG LEVEL and STABILITY controls for a stable display. See figure 4-27.

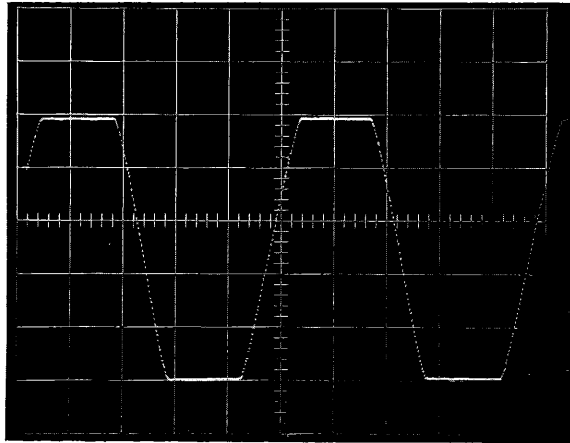
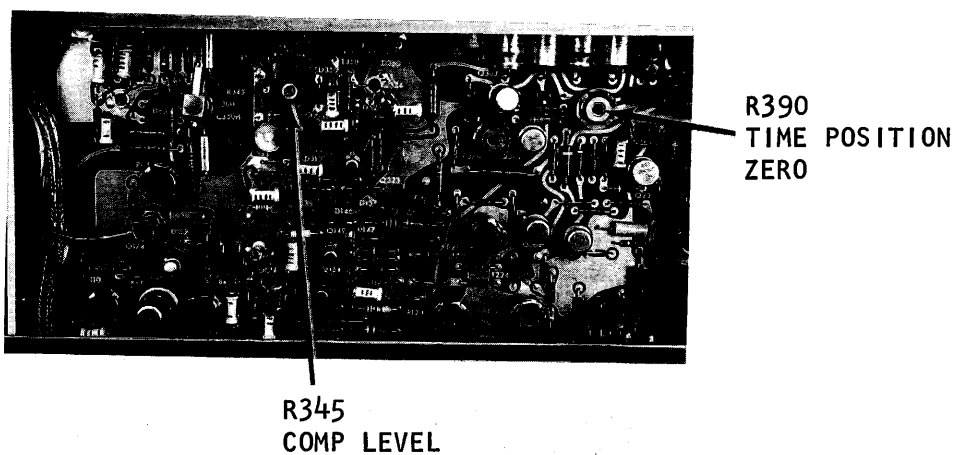
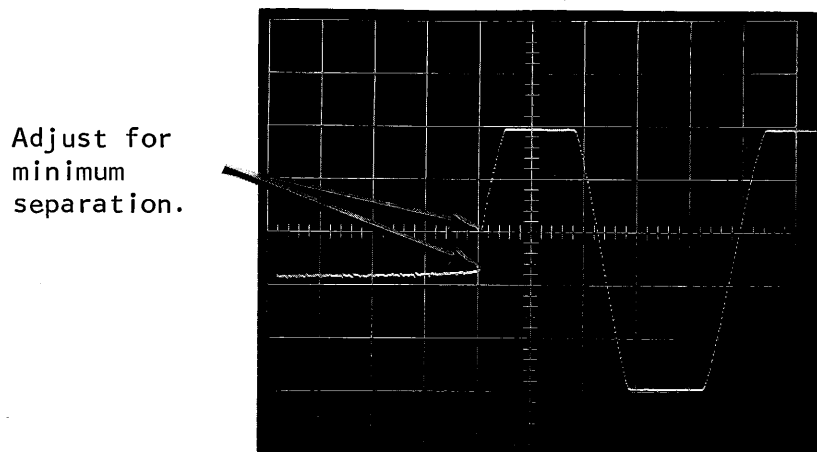

Figure 4-27

4. Preset TIME POSITION ZERO Adj. (R340 - see figure 28) full CCW.
5. Adjust COMP LEVEL Adj. (R345 - see figure 4-28A) for minimum time separation between the flat baseline and the start of the waveform (see figure 4-28B). (The correct adjustment sets R345 near the clockwise end of the range that will allow the sweep to free run.) (If the control is turned too far clockwise, the waveform will disappear.)



(A)



661 Display

(B)

Figure 4-28

6. Adjust TIME POSITION ZERO (R390 - see figure 29A) for lease distortion (see figure 29B).

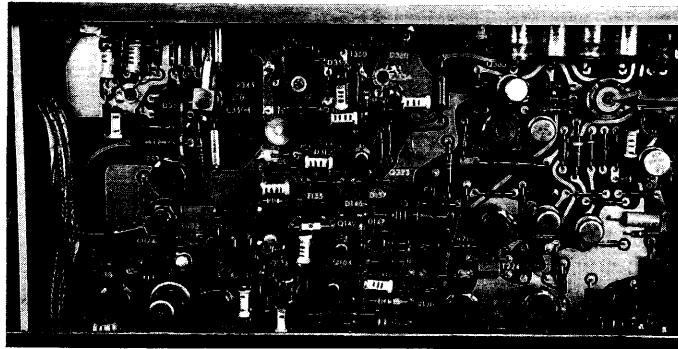

R390  
TIME POSITION  
ZERO

(A)

Misadjusted

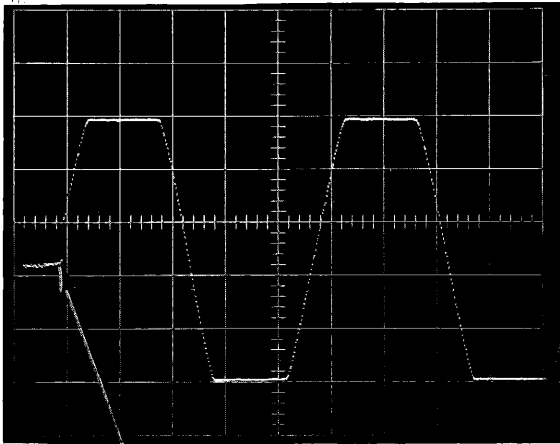

Correct Adjustment

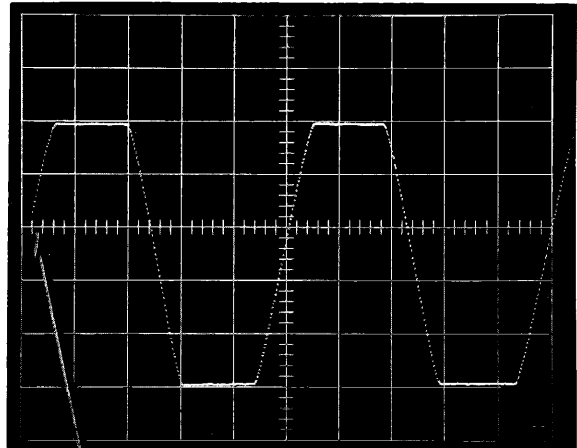

Adjust for minimum distortion at start of waveform.

(C)

Figure 4-29

## G. 1 nSEC TIMING Adjustment

1. Set the EQUIVALENT TIME/CM to 1 nSEC.
2. Two methods can be used for this particular adjustment. One is to apply 100 mc from the 661 Calibrator to the 4S1 and adjust C343 (1 nSEC/CM) for 1 cycle over the 10 cm. See figure 4-30.

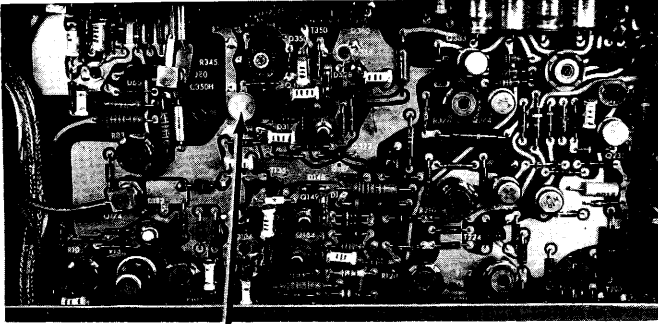

C343  
1 nSEC/CM Adj.  
(A)

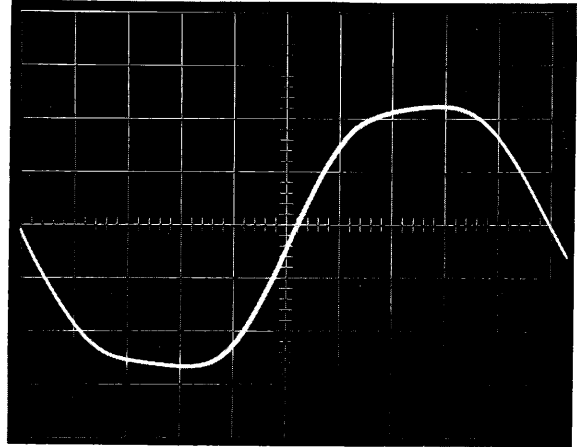

.01  $\mu$ s/cycle (100 mc)  
(B)

Figure 4-30

3. The second method is to use a 1218-A GR oscillator and apply 1000 mc to both the 4S1 INPUT and the 50 $\Omega$  EXT TRIGGER INPUT connector. Maximum EXT TRIG SIGNAL INPUT should be kept to  $\leq$  150 mv. Minimum EXT SIGNAL requirement is 5 mVOLTS.
  - a. Set the TRIG SOURCE to EXT and the EXT TRIG MODE to UHF SYNC.

- b. The frequency of the GR oscillator must first be verified by the use of a 180A, test scope and a mixer rectifier. See figure 4-31.

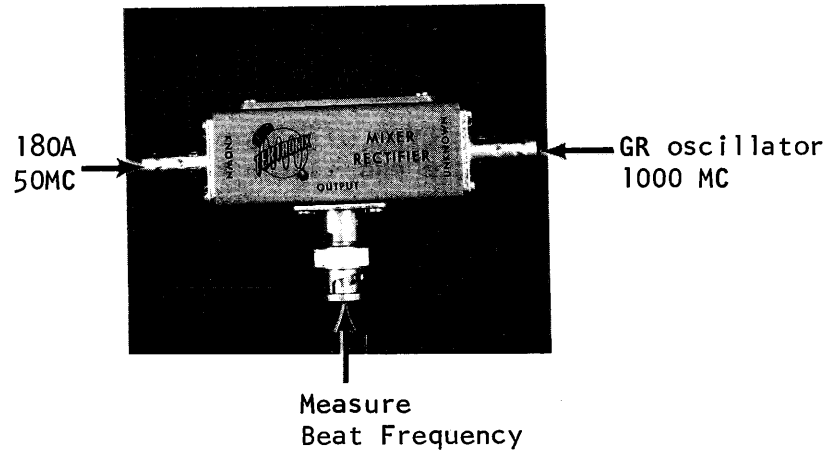

Figure 4-31

- c. Apply the 180A - 50 MC signal to the known connector on the mixer rectifier.
- d. Apply the GR oscillator - 1000 MC signal to the UNKNOWN connector. The amplitude ratio between the 180A (50 MC) and GR oscillator (1000 MC) should be approximately 1:1. The Beat frequency can be measured very easy if this ratio is used.
- e. Adjust the GR oscillator to approximate 1000 MC and with a test scope, measure the beat frequency at the output of the mixer rectifier.

- f. After the GR oscillator has been set to 1000 mc, without disturbing the frequency control, disconnect the mixer rectifier and apply the 1000 mc to the 4S1 and 5T3 EXT TRIG connector. (A GR "T" connector and several GR 50 $\Omega$  Attenuators may be required to produce the correct signal to the EXT TRIG INPUT.) Adjust triggering controls for a stable display.
- g. Adjust 1 nSEC/cm Adj. (C343 - refer to figure 4-30A) for 1 cycle/cm, see figure 4-32.
- h. The GR oscillator will be used again in Step I. Therefore disconnect the oscillator from the 4S1 input but leave it turned on.

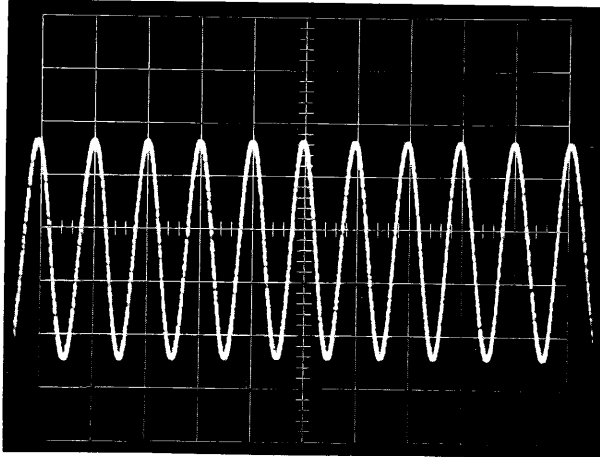
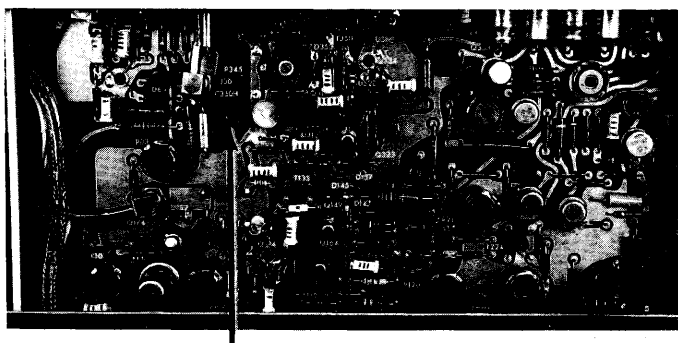

Figure 4-32

## H. 10 nSEC TIMING Adjustment

1. Apply to the 4S1 input,  $.01 \mu\text{SEC}/\text{cycle}$  (100 mc) from the 661 CALIBRATOR output.
2. Set the EQUIVALENT TIME/CM to 10 nSEC.
3. Set the TIME POSITIONS controls to midrange and adjust TRIGGERING controls for a stable display.
4. Adjust 10 nSEC TIMING capacitor (C350H - see figure 4-33) for 1 cycle/cm.



C350H  
10 nSEC TIMING

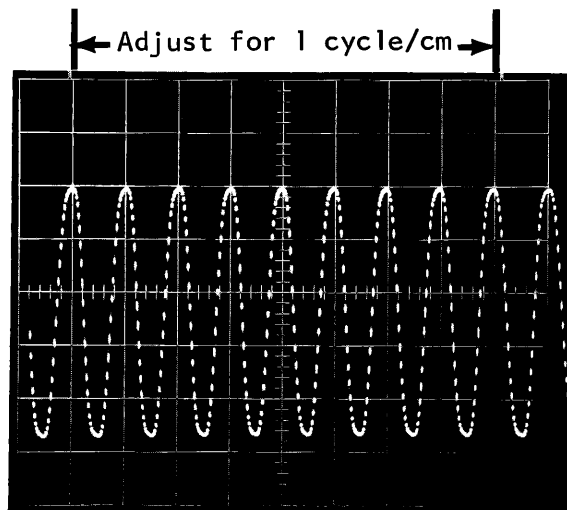

Figure 4-33

5. Check the timing of the 5 and 2 nSEC sweep ranges,  $\pm 3\%$ .



## I. TIME POSITION RANGE and LINEARITY Check

1. Preset both the TIME position Red and Black knobs full CW.
2. With 1 Gc applied to the input from the 1218-A GR oscillator set EQUIVALENT Time/cm control to 1 nSEC.
3. By adjusting the TIME positions controls from full CW to full CCW, check for  $\geq 20$  nSEC of range by observing the 1000 mc signal on the CRT.
4. Linearity of the sweep is specified as  $\pm 3\%$  over the 8 (eight) centimeter excluding the first cycle. Set the TIME POSITION control (red and black) full CW. With the FINE TIME POSITION control position one (1) cycle to the left (off screen). This allows for the inherent nonlinearity at the start of the fast ramp. Check for correct timing with the TIME POSITION (Black knob) full CW, midrange and CCW positions.
5. Using the following table check for correct linearity over the eight centimeter using the procedured outline in step 4. Also check for correct time position range.

<u>TIME POSITION RANGE</u>	<u>EQUIV. TIME BLUE INDEX</u>	<u>EQUIV. TIME/cm (MAGNIFIER)</u>	<u>INPUT SIGNAL</u>	<u>Exclude First Portion of Ramp</u>	<u>TIME ACCURACY</u>
100 nSEC	2 ns	2 ns	1 Gc (use GR osc.)	2 cycles	$\pm 3\%$
- Disconnect GR oscillator and apply 50 mc from 180A Generator.					
1 $\mu$ s	20 nSEC	5 nSEC	50 mc (use 180A)	1 cycle	$\pm 3\%$
10 $\mu$ s	.2 $\mu$ SEC	50 nSEC	5 mc	0.5 cycle	$\pm 3\%$
100 $\mu$ s	2 $\mu$ SEC	.5 $\mu$ SEC	1 $\mu$ s marker	1 marker	$\pm 3\%$
1 mSEC	20 $\mu$ SEC	5 $\mu$ SEC	10 $\mu$ s marker	1 marker	$\pm 3\%$

## J. SWEEP MAGNIFIER Accuracy Check

1. Apply 50 mc from the Type 180A to the 4S1 input. Obtain approximately 4 cm of signal and adjust triggering controls for a stable display (TRIG SOURCE to INT.)
2. Set the EQUIVALENT TIME/cm control to 2  $\mu$ SEC. Set TIME position controls to midrange.
3. Pull out the MAGNIFIER knob and turn clockwise to 20 nSEC.
4. Check for 1 cycle/cm ( $\pm 3\%$ ) over the center eight (8) cm of the graticule.
5. Set the MAGNIFIER knob to a .2  $\mu$ SEC and 5 mc from the 180A (TIME POSITION window remains at 2  $\mu$ SEC.)
6. Check for 1 cycle/cm ( $\pm 3\%$ ) over the center eight (8) cm of the graticule.
7. This test verifies accuracy of the sweep rates from 0.5 nSEC/cm through 10 psec/cm since those sweep rates are a function of the magnifier.

## V. DOTS/CM Adjustments

### A. DOTS CAL (R415)

1. Apply 50 mc from the Type 180A to the input of the 4S1.  
Obtain approximately 4 cm of signal.
2. Preset the EQUIVALENT TIME/cm to 20 nSEC.
3. Set the TRIG SOURCE to INT and adjust the triggering controls for a stable display.
4. Set the EQUIVALENT TIME/cm control to the .1  $\mu$ SEC/CM position.
5. Set the SAMPLES/CM to 5.
6. Adjust DOTS CAL (R415 - see figure 4-34) for a straight row of dots.

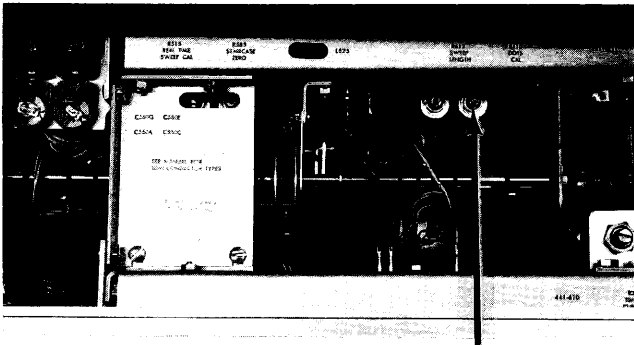

R415  
DOTS CAL

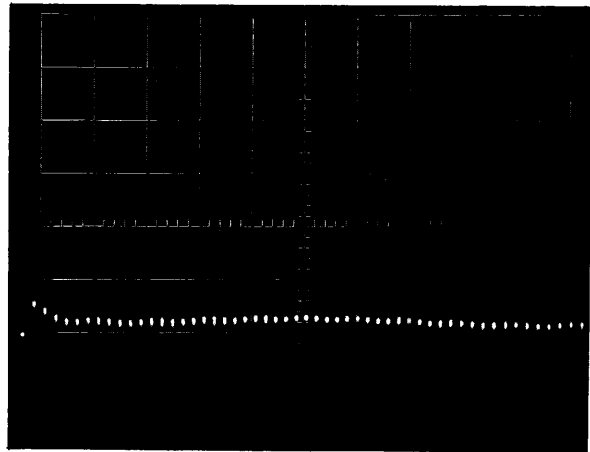

Correct Adjustment

Misadjusted

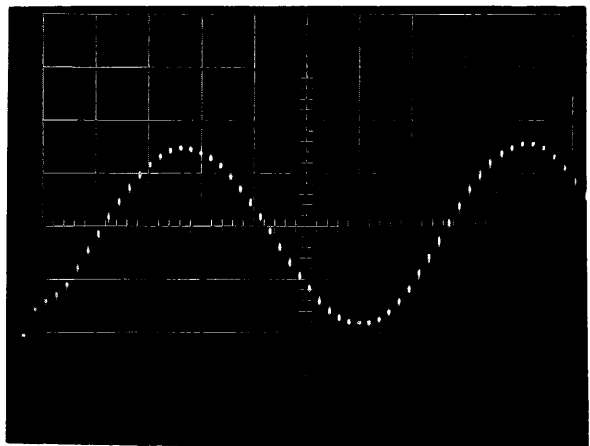
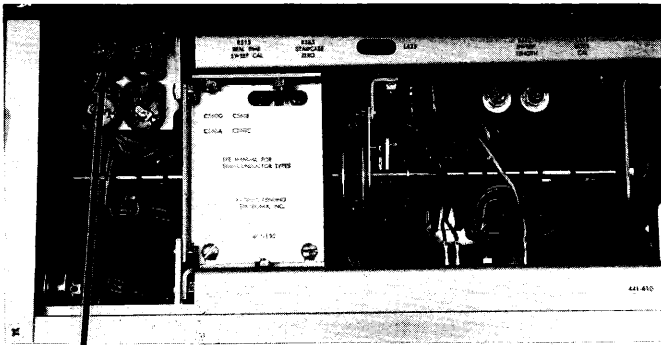

Figure 4-34

NOTE: Sweep speed = 100 nSEC/CM, INPUT signal is 50 mc = 20 nSEC.  
At 5 DOTS/CM the equivalent time between dots is 20 nSEC. With 5 dots and 50 mc we are sampling the sine wave at the same point each time which gives us a straight line on the CRT. This method of adjusting the DOTS CAL gives us better than 0.5% accuracy. Required accuracy is only  $\pm 3\%$ .

B. 10 DOTS CAL (C560G)

1. Using the same set-up as in step A, set the SAMPLES/CM to 10. (EQUIV. TIME/CM  $.1 \mu\text{SEC}$  - 50 mc input signal).
2. Adjust 10 DOTS CAL (C560G - see figure 4-35) for two straight rows of DOTS.



10 DOTS Adj.  
C560G

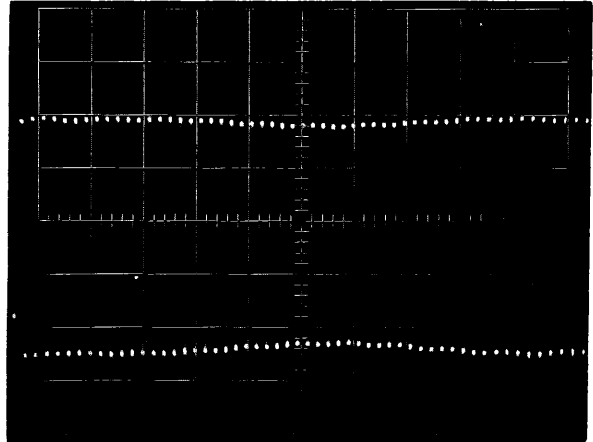
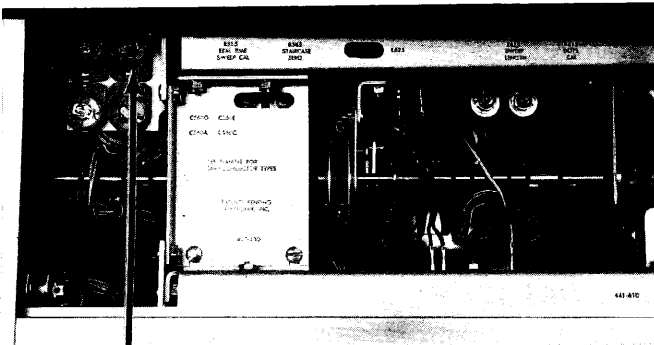

Figure 4-35

C. 20 DOTS Adj. (C560E)

1. Set the EQUIVALENT TIME/CM to  $.2 \mu\text{SEC}$ .
2. Set the SAMPLES/CM to 20.
3. Adjust 20 DOTS Adj. (C560E - figure 4-36) for two straight rows of DOTS.



20 DOTS Adj.  
C560E

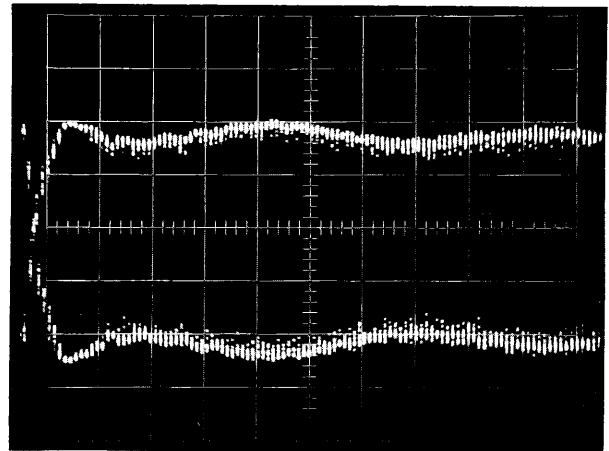
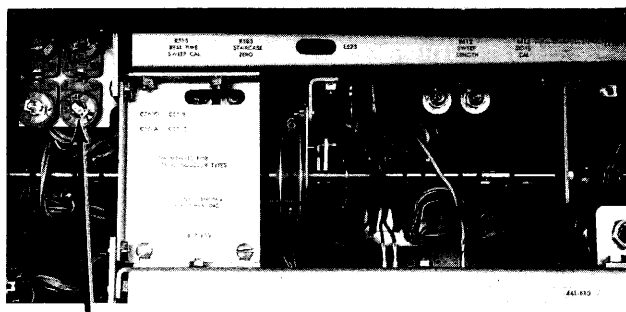

Figure 4-36

## D. 50 DOTS Adj. (C560C)

1. Set the SAMPLES/CM to 50.
2. Set the EQUIVALENT TIME/CM to .5  $\mu$ SEC.
3. Adjust 50 DOTS Adj. (C560C - see figure 4-37) for two "straight" rows of DOTS.



50 DOTS Adj.  
C560C

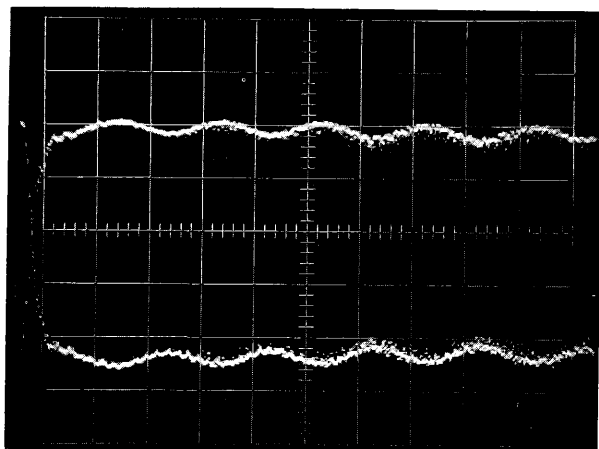
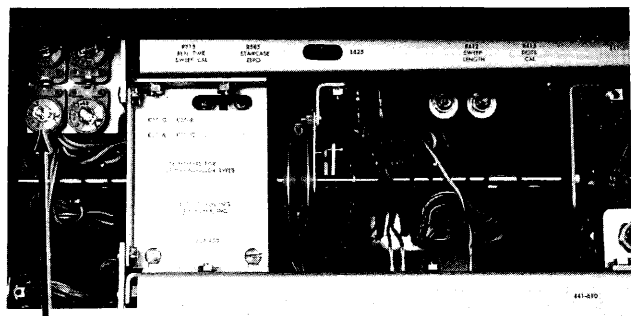

Figure 4-37

## E. 100 DOTS Adj. (C560A)

1. Set the SAMPLES/CM to 100.
2. Set the EQUIVALENT TIME CM to 1  $\mu$ sec.
3. Adjust 100 DOTS Adj. (C560A - see figure 4-38) for two "straight" rows of DOTS.



C560A  
100 DOTS Adj.

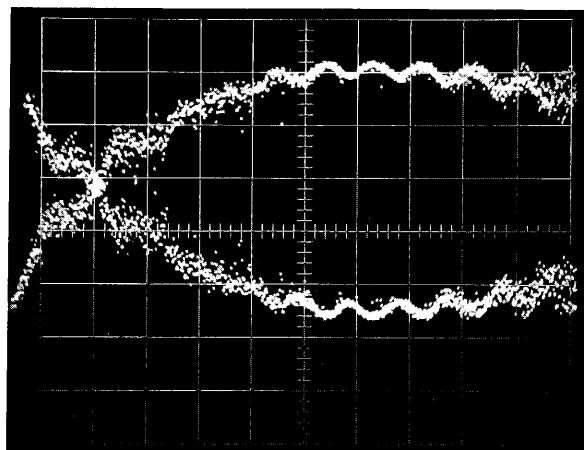

5 (Five) Crossing Allowed

Figure 4-38

## F. SAMPLES/CM TIMED POSITION Check

1. Leave the time-mark signal applied to the vertical input of the 4S1.
2. Preset the following front panel controls

EQUIVALENT TIME/CM	50 nSEC
SAMPLES/CM	TIMED
TRIG SOURCE	FREE RUN
3. Set the TIME-MARK generator for 1 second markers.
4. With a small screw driver, set the front-panel TIMED Adj. control full counter clockwise.
5. Check for  $\geq 5$  markers per cm (equivalent sweep rate of  $\geq 5$  seconds per cm).
6. Set the front panel TIMED Adj. control full clockwise.
7. Check for  $\leq 1$  marker per 2 centimeters (equivalent sweep rate of 0.5 second/cm or faster).
8. Leave the TIMED Adj. full clockwise or set it for some calibrated rate if you desire.
9. Disconnect the 180A Time-mark Generator.

## VI. TRIGGERING Checks

## A. EQUIVALENT TIME Jitter Check (500 mc)

Following are the specifications that apply for the 500 mc check.

- a.  $\leq 70$  psec of jitter for a 400 mv signal at 500 mc applied to the 4S1 with internal triggering.
- b.  $\leq 70$  psec of jitter for a 50 mv signal at 500 mc applied to the 50 $\Omega$  external input, DC coupled.
- c.  $\leq 300$  psec of jitter for a 5 mv signal at 500 mc applied to the 50 $\Omega$  external input, DC coupled.
- d.  $\leq 300$  psec of jitter for a 40 mv signal at 500 mc applied to the 4S1 with internal triggering.

1. Preset the following front panel controls.

STABILITY	AUTO RECOVERY
TRIG SOURCE	INT
SLOPE	+
EXT TRIG MODE	50 $\Omega$ - DC
EQUIVALENT TIME/CM	1 nSEC
SAMPLES/CM	100
TIME POSITION	midrange
SWEEP MODE	normal
661 AMPLITUDE/TIME CAL.	OFF (The calibrator could introduce some jitter if it was left on.)

2. Apply to the input of the 4S1, a 500 mc signal from a GR oscillator (Type 1209-B). Obtain 400 mv of signal. Use a GR "T" connector at the input to supply an External TRIG signal for the following steps. (To be able to vary the output of the GR oscillator conveniently, the Type 111 variable atten. can be used). See figure 4-39.

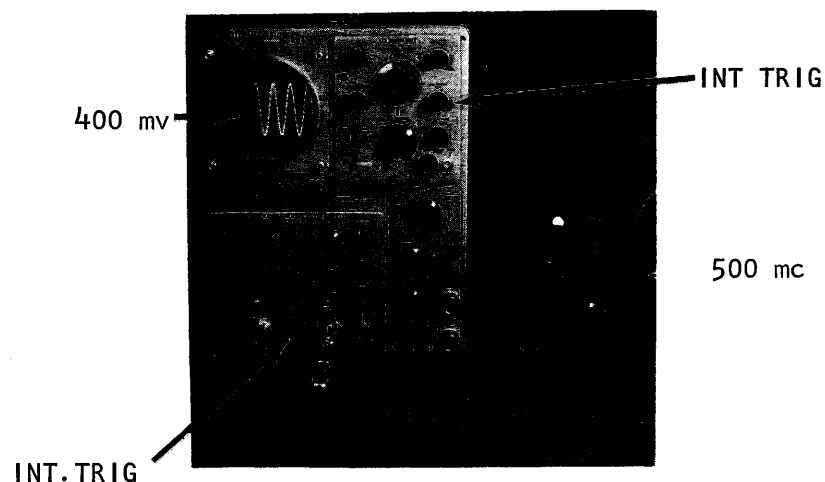

Figure 4-39

3. Set the 4S1 TRIGGERING and MODE controls for the correct channel.
4. Adjust the TRIG LEVEL control for the best stable display. See figure 40.

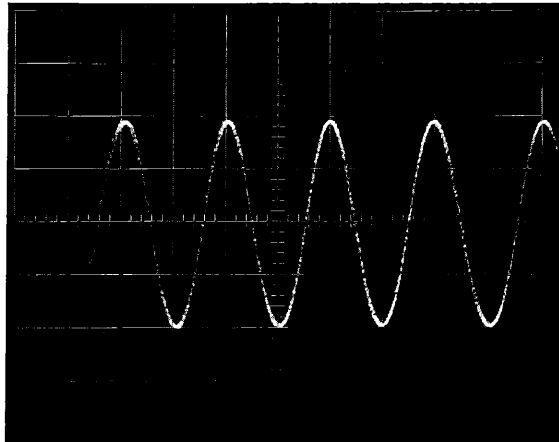
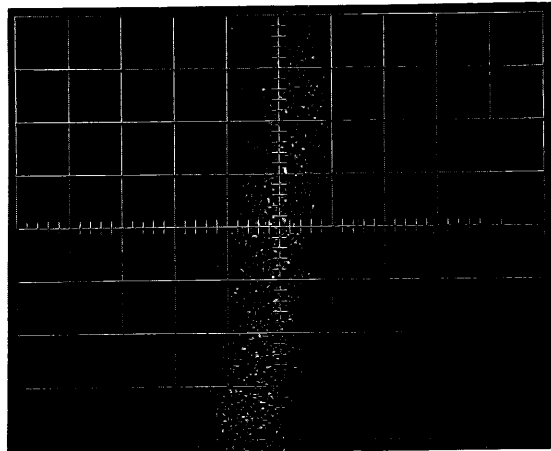

Figure 40

5. Pull out the MAGNIFIER control and set to 50 pSEC/cm.
6. Set the 4S1 MILLIVOLTS/cm to 5 or 2 millivolts position and check for  $\geq 70$  pSEC of jitter (1.4 cm of trace width). (Jitter is measured by the width of the 500 mc pulse expanded horizontally and vertically.) See figure 4-41.



The jitter is measured by observing the trace width (90% of dots fall within 1.4 cm).

Figure 4-41



7. Set the millivolts/cm to 100 millivolts position reset MAGNIFIER switch back to 1 nSEC position.
8. Connect a X10 Atten to the "T" connector and a 50 $\Omega$  cable to the 50 $\Omega$  EXT TRIG INPUT.
9. Adjust for 500 mv - 500 mc signal on the CRT (50 mv to EXT TRIG INPUT). See figure 4-42.

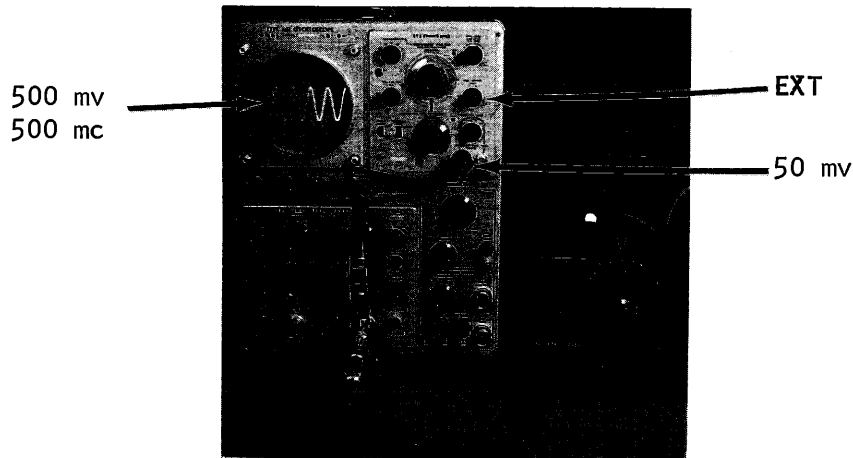

Figure 4-42

10. Set the TRIG SOURCE to EXT and EXT TRIG MODE to DC.
11. Adjust TRIG LEVEL control for a stable display.
12. Set the MAGNIFIER switch to 50 pSEC and the MILLIVOLTS/cm switch to 2. Check for  $\geq 70$  PSEC of jitter (see figure 4-41).
13. Check the following triggering jitter specs using the preceding procedure.
  - a.  $\leq 300$  pSEC jitter for a 500 mc signal at 40 mv signal applied to the 4S1 with INTERNAL triggering.
  - b.  $\leq 300$  pSEC jitter for a 500 mc signal at 5 mv signal applied to the 5T3 EXT 50 $\Omega$  INPUT connector.
14. Disconnect the 500 mc oscillator.

**B. EQUIVALENT TIME PULSE TRIGGERING Check**  
(20 nSEC time position range position)

Following are the specifications that apply for the pulse jitter check.

- (a.)  $\leq 30$  pSEC of jitter for a 400 mv pulse signal (pulse shape, 2 nSEC wide, 1 nSEC or less risetime,  $\leq 100$  kc repetition rate) applied to the 4S1 with internal triggering.
  - (b.)  $\leq 30$  pSEC of jitter for a 50 mv pulse applied to the EXT TRIG ( $50\Omega$ ) input, DC coupled.
  - (c.)  $\leq 300$  pSEC of jitter for a 40 mv pulse applied to the 4S1 with internal triggering.
  - (d.)  $\leq 300$  pSEC of jitter for a 5 mv pulse applied to the EXT TRIG ( $50\Omega$ ) input, DC coupled.
1. Preset the Type 111 controls for approximately 100 kc rep rate signal and + OUTPUT polarity. Do not connect a charge line to the connector on the back panel.
  2. Connect the output of the Type 111 through a X10 ATTEN, Type 111 VARIABLE ATTEN and a GR "T" connector to the input of the 4S1. See figure 4-43.

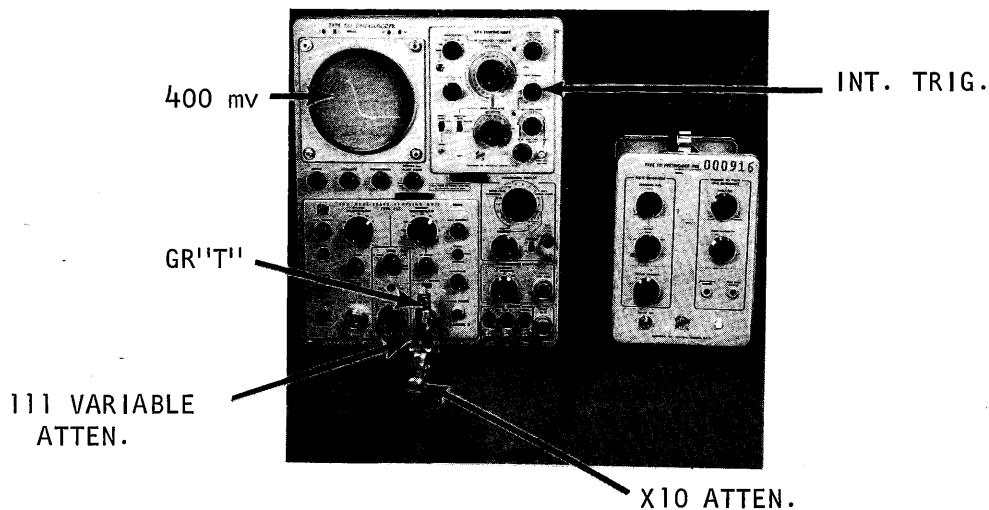

Figure 4-43

3. Set the MILLIVOLTS/CM switch to 100 and adjust Type 111 VARIABLE Attenuator for 4 cm (400 mc) of signal (INT. trigger the 4S1).
4. Set the 5T3 controls for INT triggering and adjust TRIG LEVEL control for a stable display. See figure 4-44.  
(The TIME POSITION control may require adjusting to display the signal on the CRT). (EQUIVALENT TIME/CM to 1 nSEC).

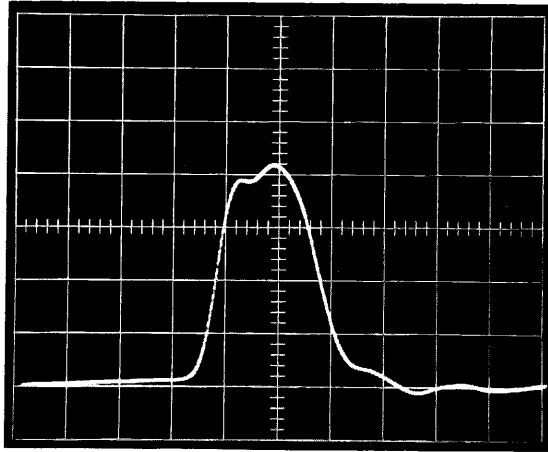

Figure 4-44

5. Pull out the MAGNIFIER knob and set to 20 pSEC/CM position.
6. Adjust the TIME POSITION control to display the "rise" of the pulse.
7. Set the 4S1 MILLIVOLTS/CM to 5 or 2 position and check for  $\leq 30$  pSEC of jitter (1.5 cm of trace width - 90% of dots), see figure 4-45.

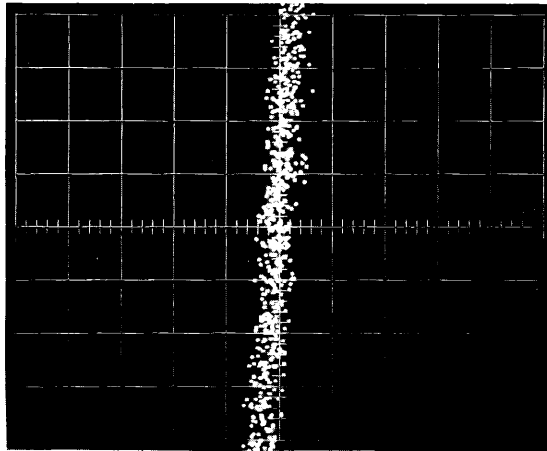

FIGURE 4-45

8. Reset the MILLIVOLTS/CM to 100 position and reset the MAGNIFIER switch back to 1 nSEC position.
9. Connect a X10 Atten to the "T" connector and a 50 $\Omega$  cable to the 50 $\Omega$  EXT TRIG INPUT.
10. Adjust for 500 mv of signal on the CRT (50 mv to EXT TRIG INPUT), see figure 4-46.

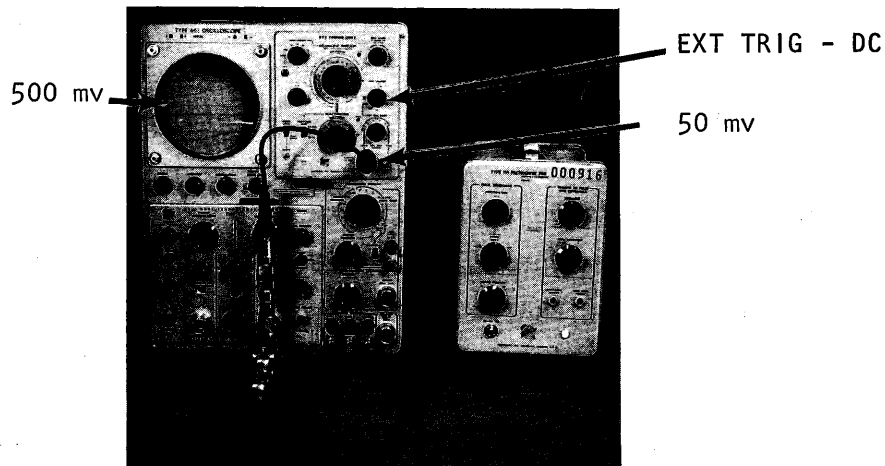

Figure 4-46

11. Set the TRIG SOURCE to EXT and EXT TRIG MODE to DC.
12. Adjust TRIG LEVEL control for a stable display.
13. Set the MAGNIFIER switch to 20 pSEC and the MILLIVOLTS/CM switch to 2. Check for  $\leq 30$  pSEC of jitter (refer to figure 4-45).
14. Check the following triggering jitter specs using the preceding procedure.
  - a.  $\leq 300$  pSEC of jitter for a 40 mv pulse applied to the 4S1 and internal triggering.
  - b.  $\leq 300$  pSEC of jitter for a 5 mv signal applied to the EXT TRIG 50 $\Omega$  INPUT.
15. Leave the Type 111 connector for the next step.

- C. 100 nSEC TIME-POSITION Range Jitter Check.
1. With the Type 111 connector as in step B, set the EQUIVALENT TIME/CM to 2 nSEC position.
  2. Set the Type 111 VARIABLE ATTEN to display 400 mv P-P and reset 5T3 control for INTERNAL triggering.
  3. Adjust TRIG LEVEL and TIME position control to display a stable signal.
  4. Set the MAGNIFIER control to 50 pSEC and MILLIVOLTS/CM control to 2. Check for  $\leq 40$  pSEC of jitter (.8 cm).
  5. Disconnect the Type 111 Pulse Generator, Atten and connector.
- D. TIME-POSITION Range Jitter Check
1. Connect the output of the 661 Calibrator to the 4S1 input. Set the CALIBRATOR for 100 mv output. Internal trigger the calibrator signal and adjust TRIG.LEVEL control for a stable display.
  2. Using the following table, check each TIME-POSITION Range (1 nSEC, 100  $\mu$ s, 10  $\mu$ s and 1  $\mu$ s) for jitter.

<u>TIME POSITION RANGE</u>	<u>SET EQUIVALENT TIME/CM to</u>	<u>661 TIME CAL to</u>	<u><math>\leq</math> JITTER</u>	<u>ALL POSITIONS</u>
1 $\mu$ s	20 nSEC	.01 $\mu$ s/cycle	$\leq 400$ pSEC	*
10 $\mu$ s	.2 $\mu$ SEC	.1 $\mu$ SEC/cycle	$\leq 4$ nSEC	*
100 $\mu$ s	2 $\mu$ SEC	1 $\mu$ SEC/cycle	$\leq 40$ nSEC	*
1 mSEC	20 $\mu$ SEC	10 $\mu$ SEC/cycle	$\leq 400$ nSEC	*

\*Set MAGNIFIER and MILLIVOLTS/CM controls to check for Jitter (MAGNIFY Sweep by 100 for best results.

3. Disconnect the 661 Calibrator signal.

## E. EXTERNAL UHF SYNC MODE Check

Following are the specifications for Externally triggering using UHF SYNC MODE.

- a.  $\leq 70$  pSEC of jitter for a 2 Gc signal Externally triggered with 5 mv.
- b.  $\leq 30$  pSEC of jitter for a 2 Gc signal Externally triggered with 10 mv.
- c.  $\leq 70$  pSEC of jitter for a 5 Gc signal Externally triggered with 10 mv.
- d.  $\leq 30$  pSEC of jitter for a 5 Gc signal Externally triggered with 50 mv.

## 1. 2 Gc EXT TRIG Check (Step a and b above)

- a. Remove the 4S1 vertical plug-in from the 661 oscilloscope and insert the 4S2 vertical plug-in.
- b. Apply from the GR 1218-A oscillator to the 4S2 input, a 2 Gc signal. Use a X10 and/or X5 Atten and GR "T" connector between the 4S2 and GR oscillator.
- c. Connect a X10 Atten between the 50 $\Omega$  EXT TRIG INPUT connector and the GR "T" connector. See figure 4-47.
- d. Preset the following 5T3 front panel controls.

TRIG SOURCE	EXT
TRIG SLOPE	+
EXT TRIG MODE	UHF SYNC
EQUIVALENT TIME/CM	.2 nSEC
(Blue insert set to 1 nSEC position and MAGNIFIER set to .2 nSEC.)	

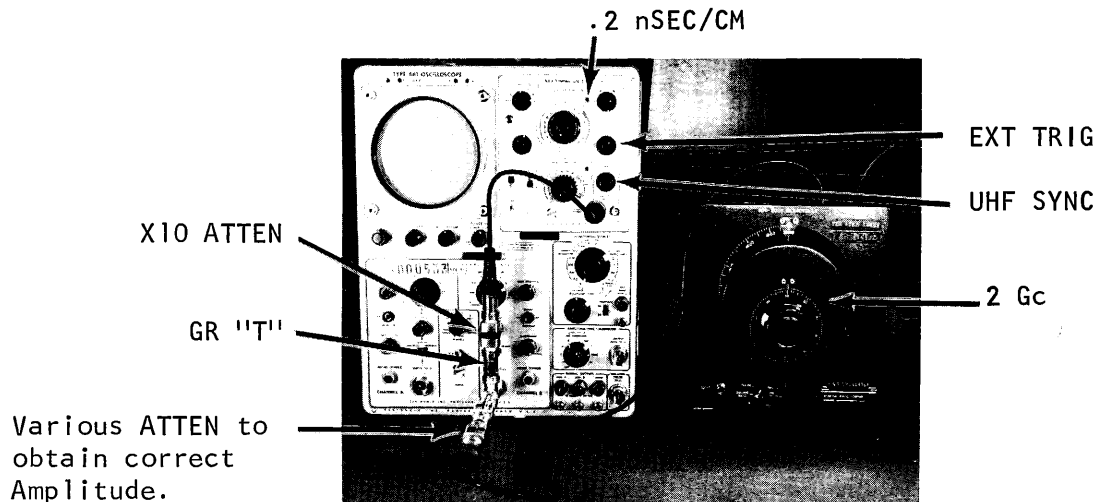

Figure 4-47

- e. Set the 4S2 MILLIVOLTS/CM control to 10, SMOOTHING control to NORMAL and MODE switch to the correct channel.
- f. Adjust and select GR Atten's to obtain 5 cm (50 millivolts) on the CRT. (5 millivolts signal supplied to the EXT TRIG INPUT connector.)
- g. Adjust STABILITY control for the best triggered display. See figure 4-48.

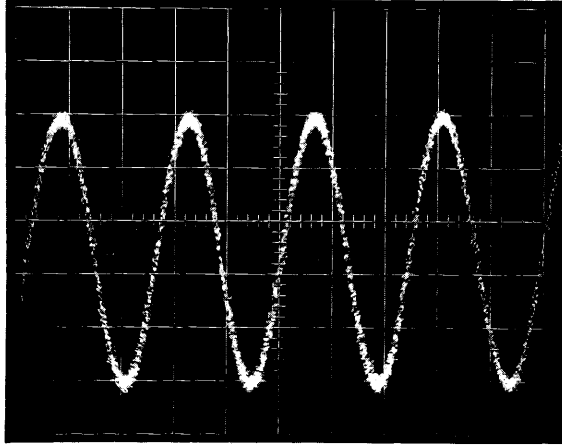
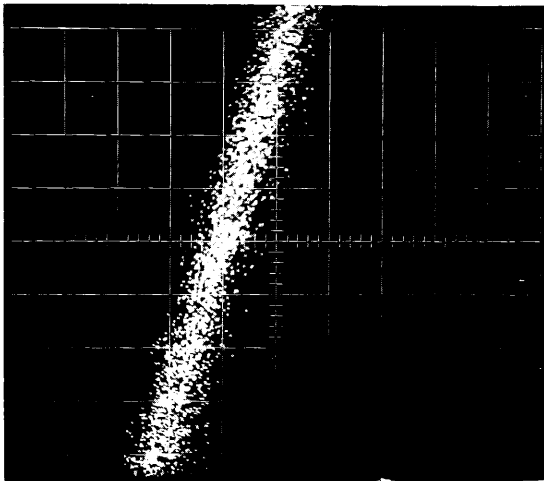

Figure 4-48

- h. Set the 4S2 MILLIVOLTS/CM control to the 5 position and the 5T3 EQUIVALENT TIME/CM MAGNIFIER control to 50 pSEC position. Check for  $\leq 70$  pSEC of Jitter (1.4 cm), see figure 4-49.



Check for  $\leq 70$  pSEC  
of Jitter (1.4 cm)

TIME/CM = 50 pSEC

(Do not use the 2  
position of the 4S2  
MILLIVOLTS/cm switch.  
Smoothing will not give  
you the correct Jitter  
measurement.)

Figure 4-49

- i. Reset 5T3 EQUIVALENT TIME/CM MAGNIFIER to .2 nSEC and the 4S2 MILLIVOLTS/CM control to 20. Adjust and select Atten to obtain 5 cm (100 mv) displayed on the CRT (10 mv applied to the EXT TRIG INPUT). Adjust STABILITY control for the best triggered display.
- j. Check for  $\leq 30$  pSEC of Jitter with a 2 Gc signal externally triggered by 10 mv using the procedure outlined in step h, above.
- k. Disconnect the 1218-A GR oscillator.

## 2. 5 Gc EXT TRIG Check

There has been no firm decision at this time which High Frequency generators will be made available to the Field. We will use the POLORAD Model 1107 generator for this procedure.

- a. Apply power to the POLORAD Signal Generator and preset the following front panel controls.

MODULATION SELECTOR	CW
FREQUENCY GC	5.00
POWER SET	CAL (as read on the meter)
ATTENUATOR	200K (200 mv)

See figure 4-50.

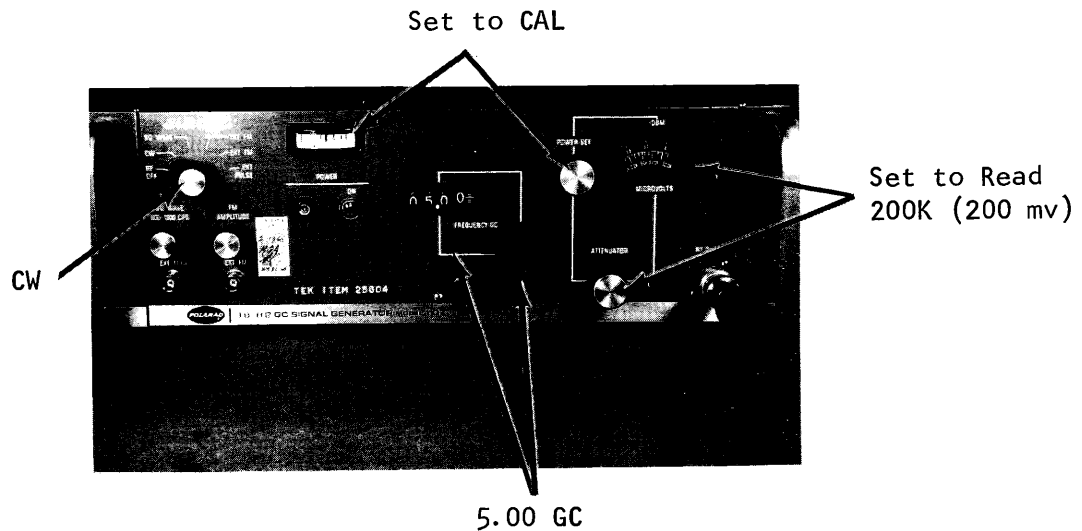

Figure 4-50



- b. Connect a X10 Atten to the 50 $\Omega$  EXT TRIG INPUT connector and a X2 connector with a GR "T" at the input of the 4S2. (Set 4S2 MILLIVOLTS/CM control to either 10 or 20 position.)
- c. Apply the 5GC (200 mv) through a X2 Atten to one side of the GR "T". Connect the other side of the GR "T" using a GR cable to the X10 Atten (input of 5T3), see figure 4-51.
- d. With the above arrangement, we hope the VSWR is at a minimum and we have 10 mv of signal at the 50 $\Omega$  EXT TRIG INPUT connector.

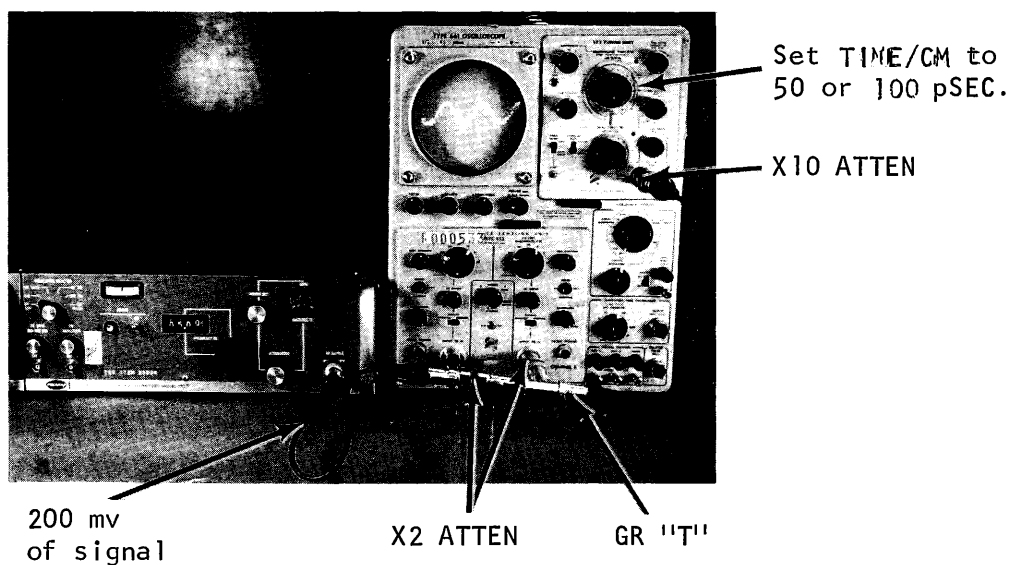
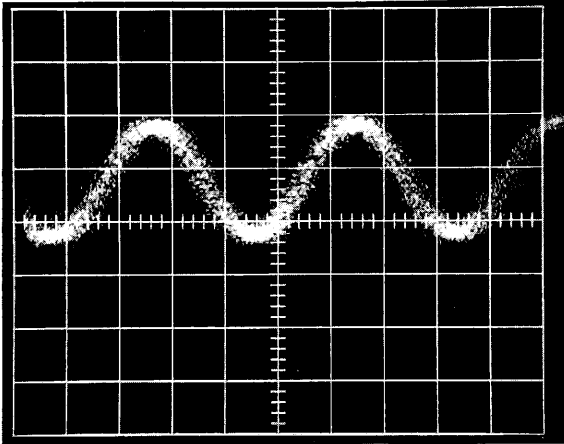

Figure 4-51

- e. Set the TRIG SOURCE to EXT, EXT TRIG MODE control to UHF SYNC, and adjust STABILITY control for a stable display. See figure 4-52.



TIME/CM = 50 pSEC

Figure 4-52

- f. Set the MILLIVOLTS/CM to 5 and set the EQUIVALENT TIME/CM MAGNIFIER to a fast sweep speed (50 or 20 pSEC/CM). Check for  $\leq 70$  pSEC of Jitter with a 10 mVolt External triggering signal. See figure 4-53.

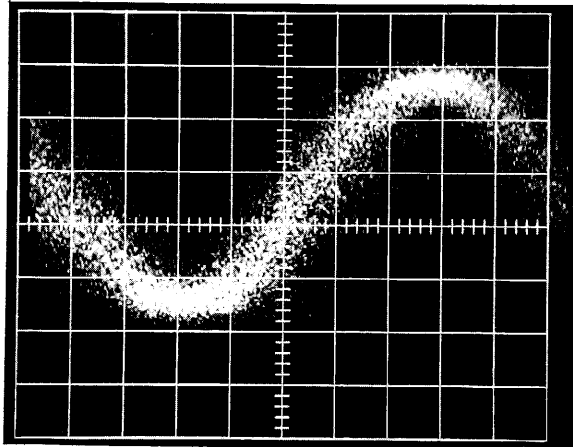
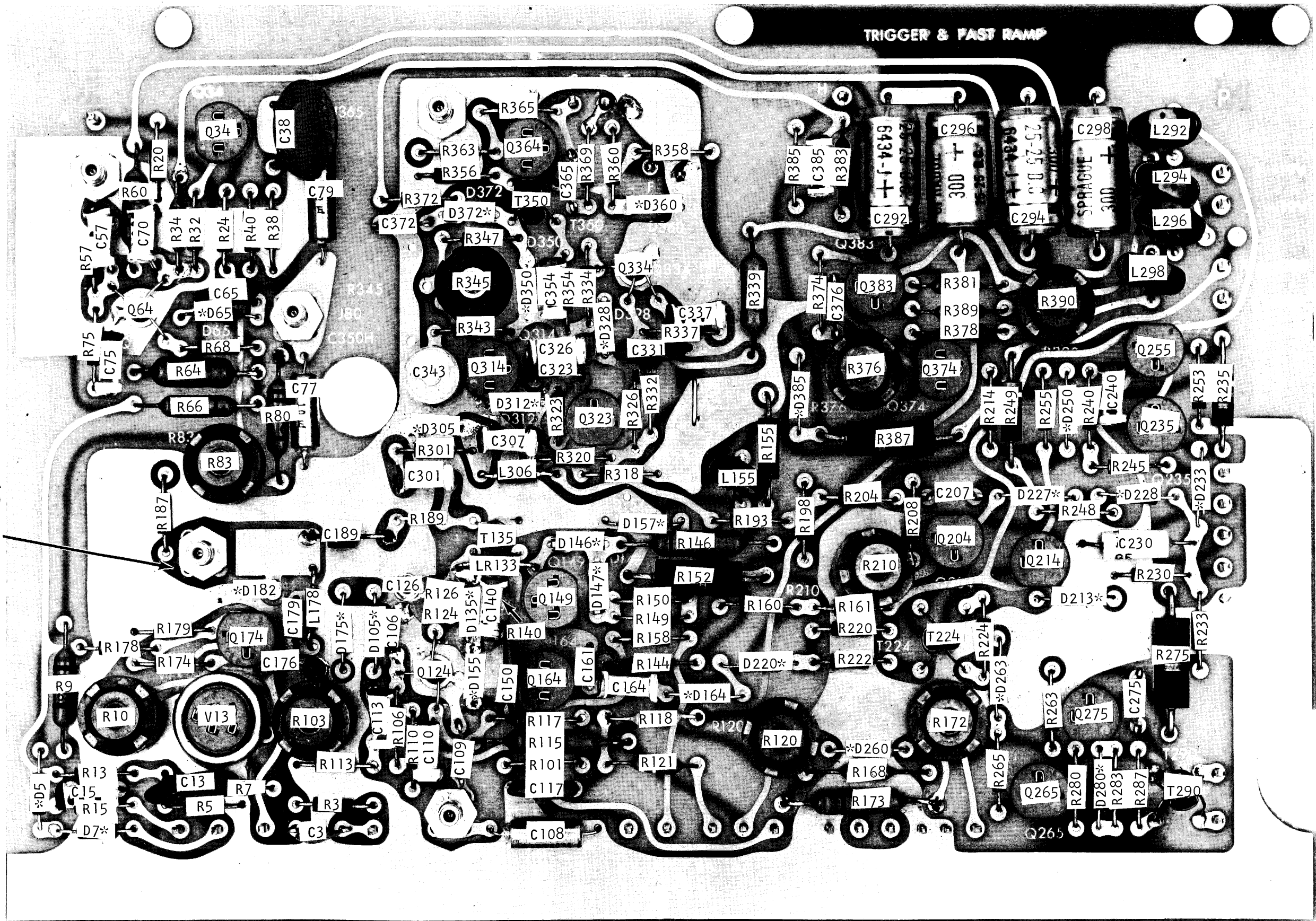

Figure 4-53

- g. Remove the X10 Atten and install a X2 Atten to the input of the 5T3 EXT TRIG connector. This will apply "50 mv" of triggering signal to the 5T3.
- h. Adjust the STABILITY control for a stable display and check for  $\leq 30$  pSEC of jitter with 50 mVolt of External triggering signal.
- i. Disconnect the equipment and the various attenuators and "T" connectors.

TRIGGER & FAST RAMP

UNDER BOARD  
R183  
R184



\* = CATHODE

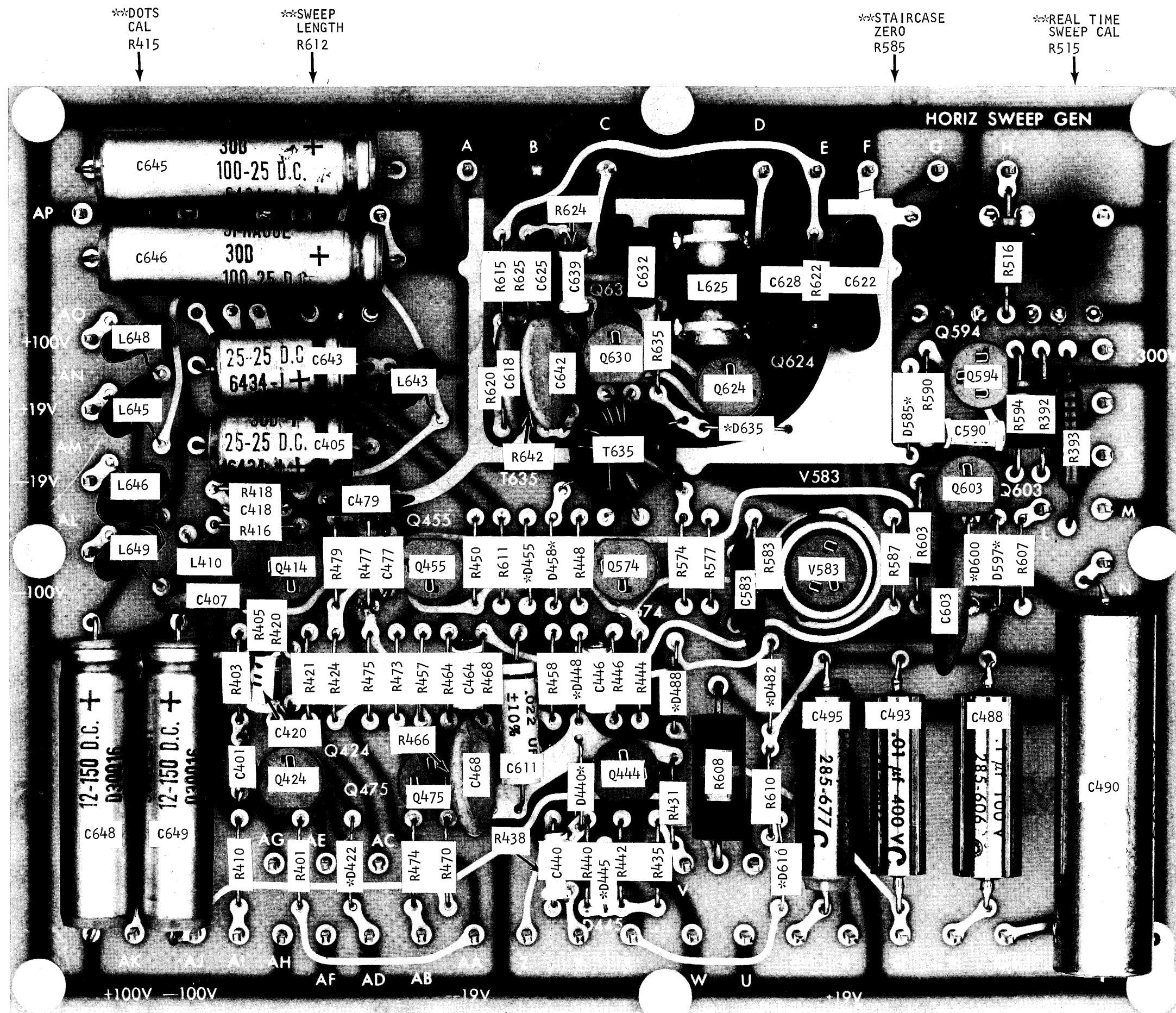

\*\*Other Side of Board

\* = CATHODE

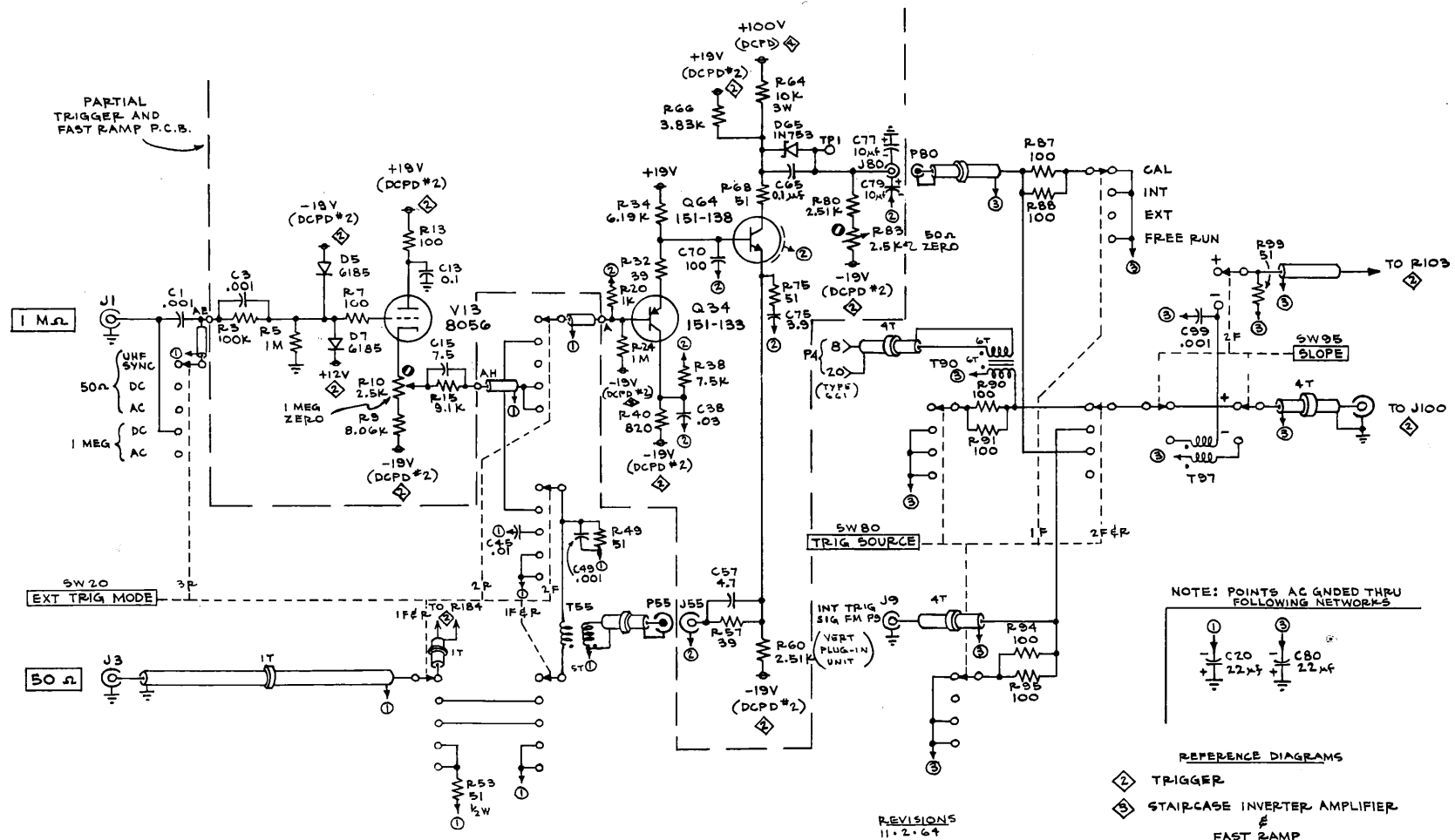

TYPE 5T3 TIMING UNIT

- REVISIONS
- 11-2-64
  - 11-13-64
  - 12-23-64
  - 12-28-64
  - 01-08-65
  - 01-28-65

- REFERENCE DIAGRAMS
- ② TRIGGER
  - ⑤ STAIRCASE INVERTER AMPLIFIER & FAST RAMP

EXT TRIGGER INPUT & TRIGGER SWITCHING

①

09-23-64

C-5T3-0001

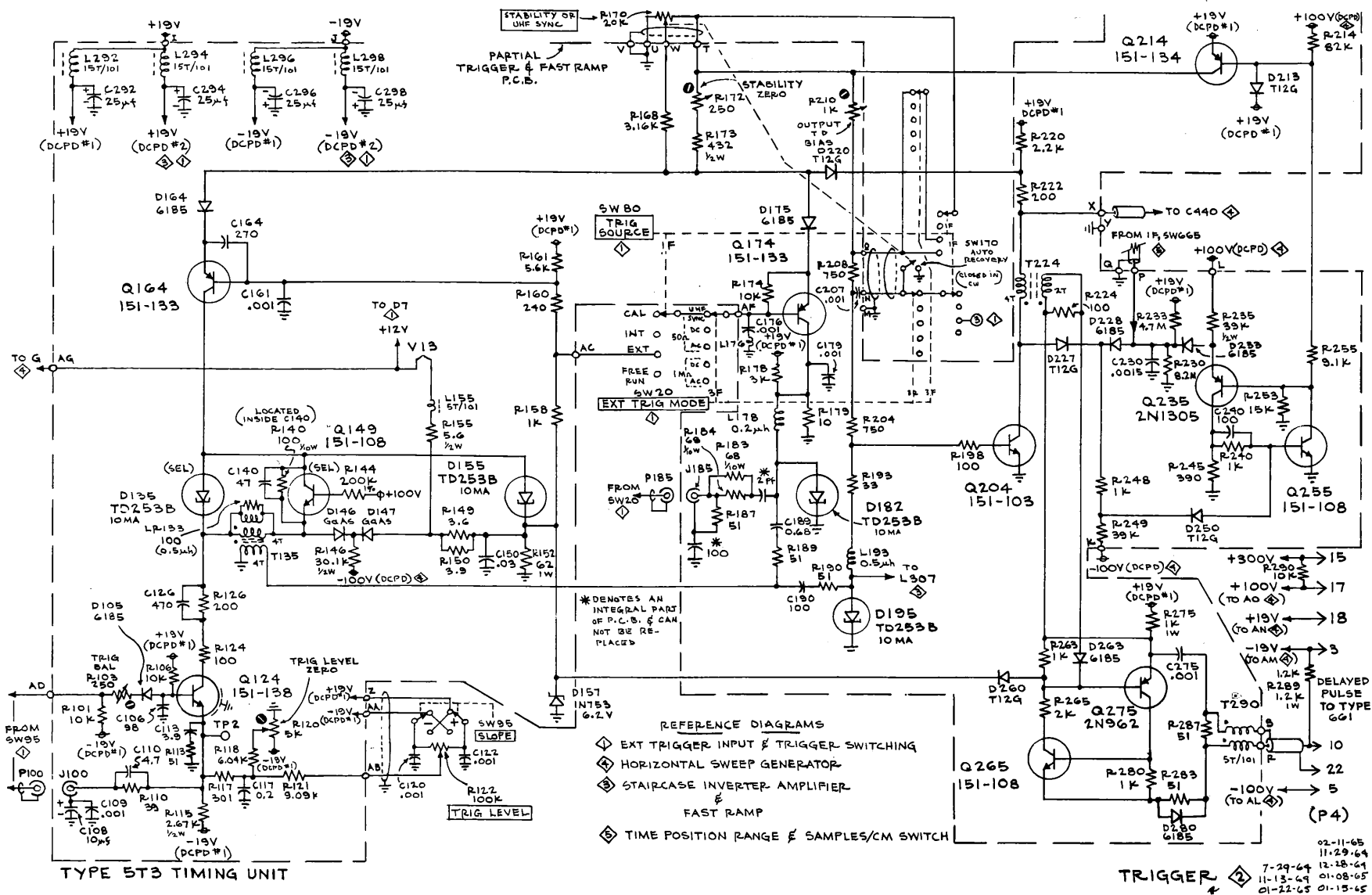

C-5T3-0002

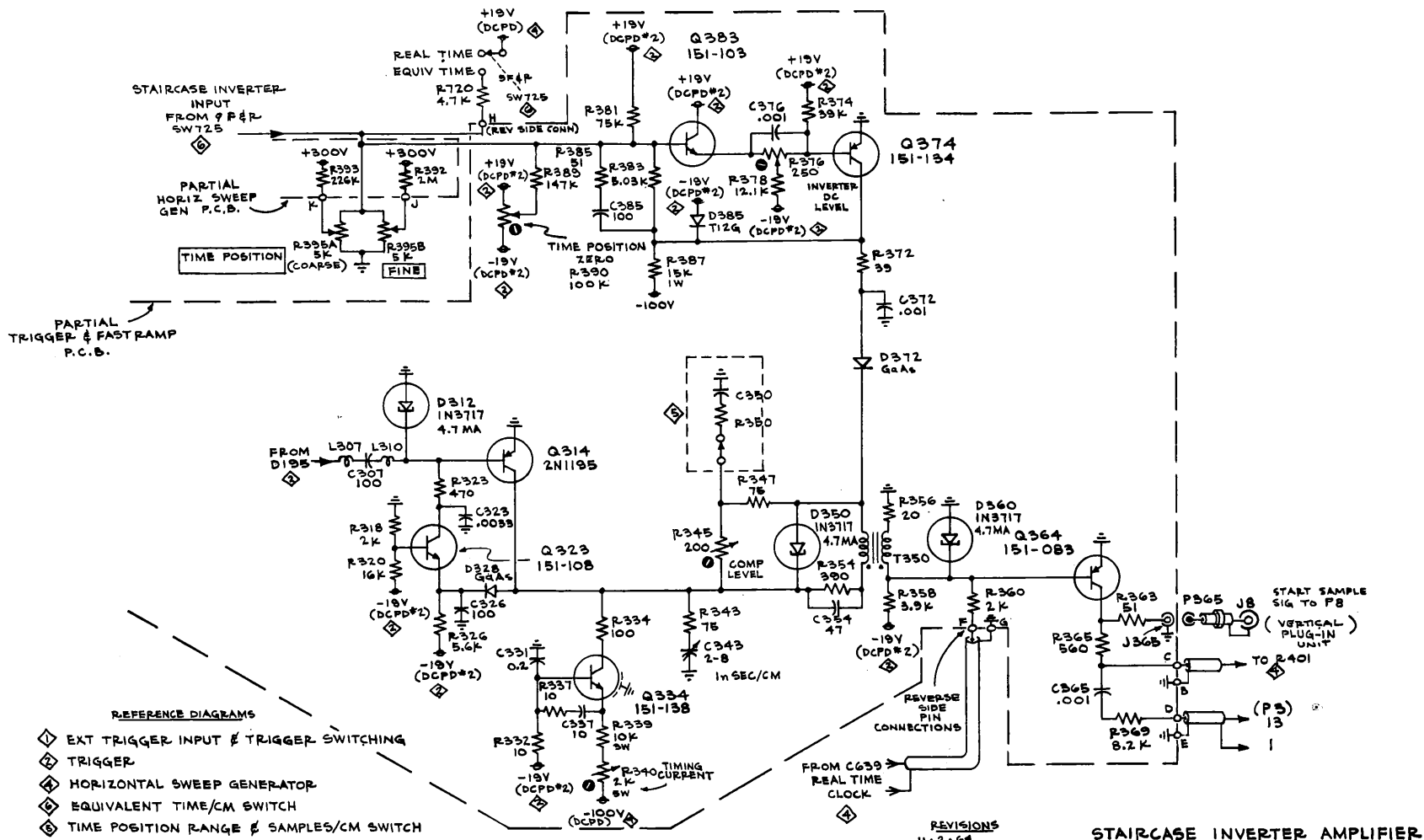

C-5T3-0003



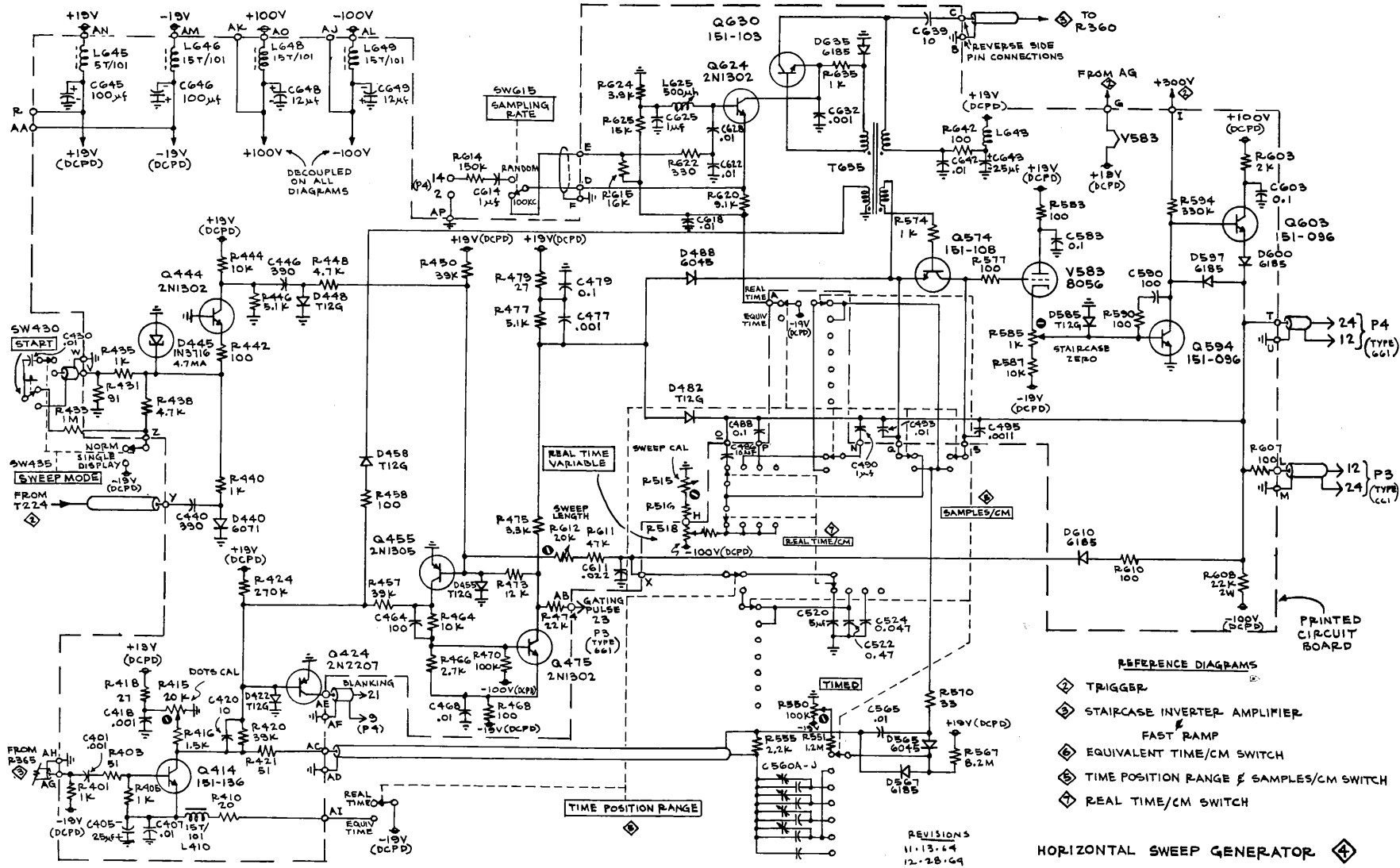

TYPE 5T3 TIMING UNIT

REFERENCE DIAGRAMS

- ② TRIGGER
- ③ STAIRCASE INVERTER-AMPLIFIER
- ④ FAST RAMP
- ⑤ EQUIVALENT TIME/CM SWITCH
- ⑥ TIME POSITION RANGE & SAMPLES/CM SWITCH
- ⑦ REAL TIME/CM SWITCH

HORIZONTAL SWEEP GENERATOR ④

REVISIONS  
11-13-64  
12-28-64

05-23-64

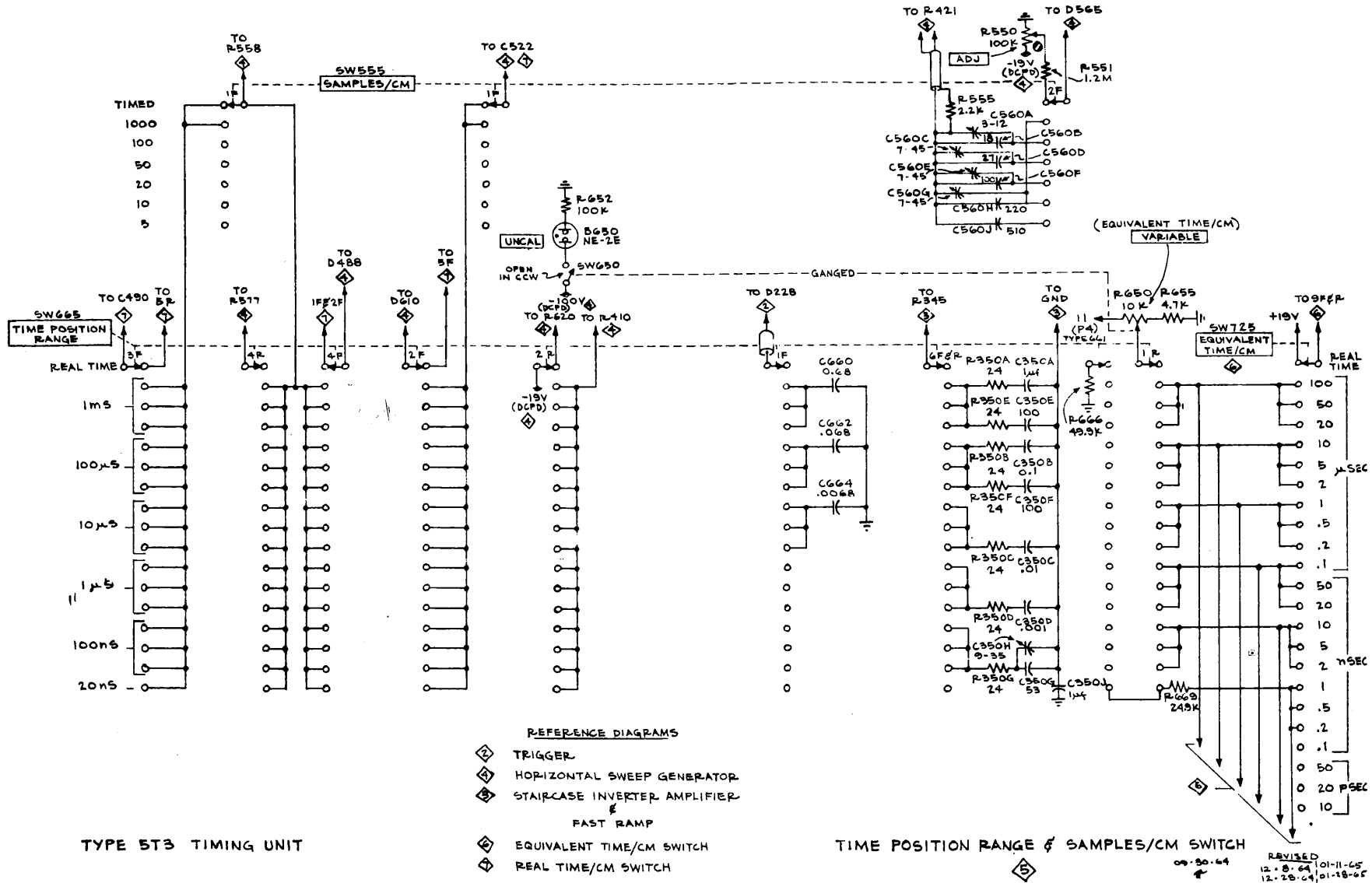

C-5T3-0005

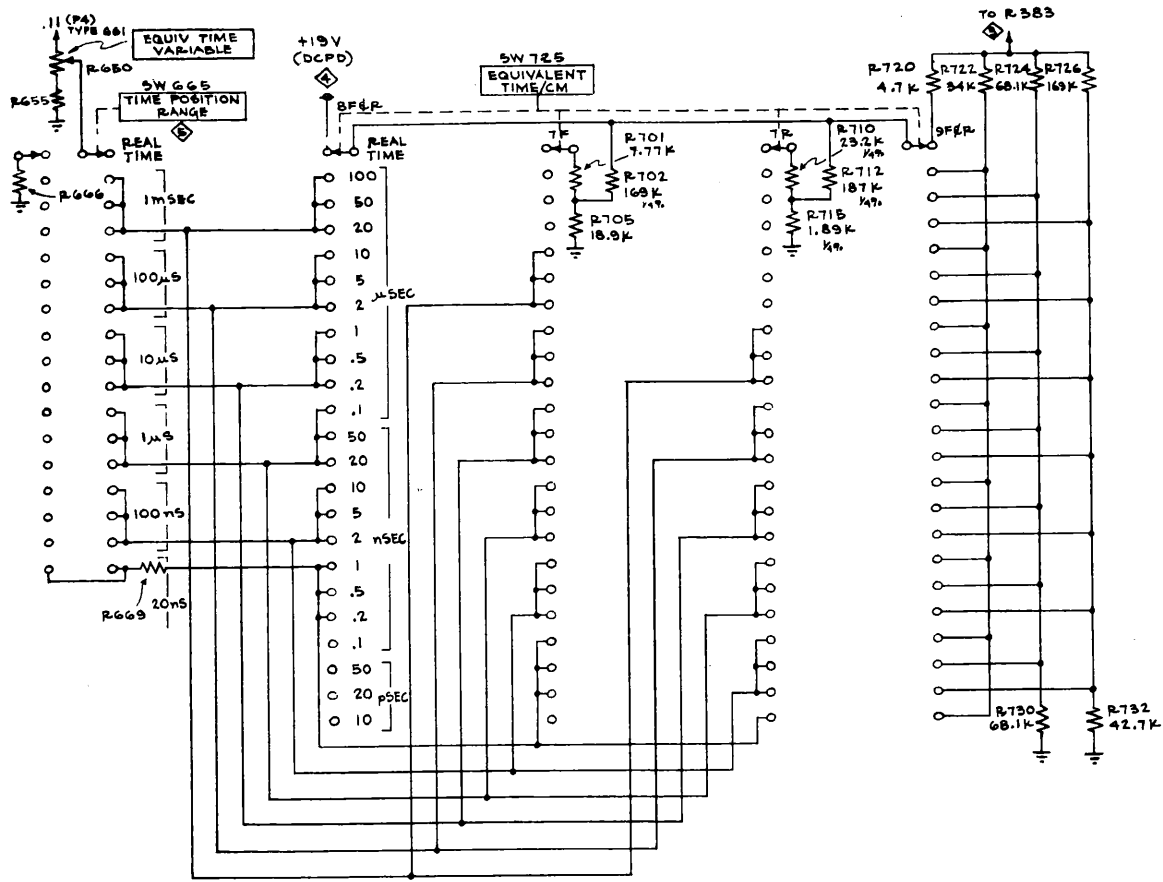

TYPE 5T3 TIMING UNIT

REFERENCE DIAGRAMS

- ⬠ HORIZONTAL SWEEP GENERATOR
- ⬠ STAIRCASE INVERTER AMPLIFIER
- ⬠ TIME POSITION RANGE & SAMPLES/CM SWITCH
- ⬠ REAL TIME/CM SWITCH

REVISIONS  
 11-2-64  
 12-29-64  
 01-11-65

EQUIVALENT TIME/CM SWITCH ⬠

09-22-64

C-5T3-0006

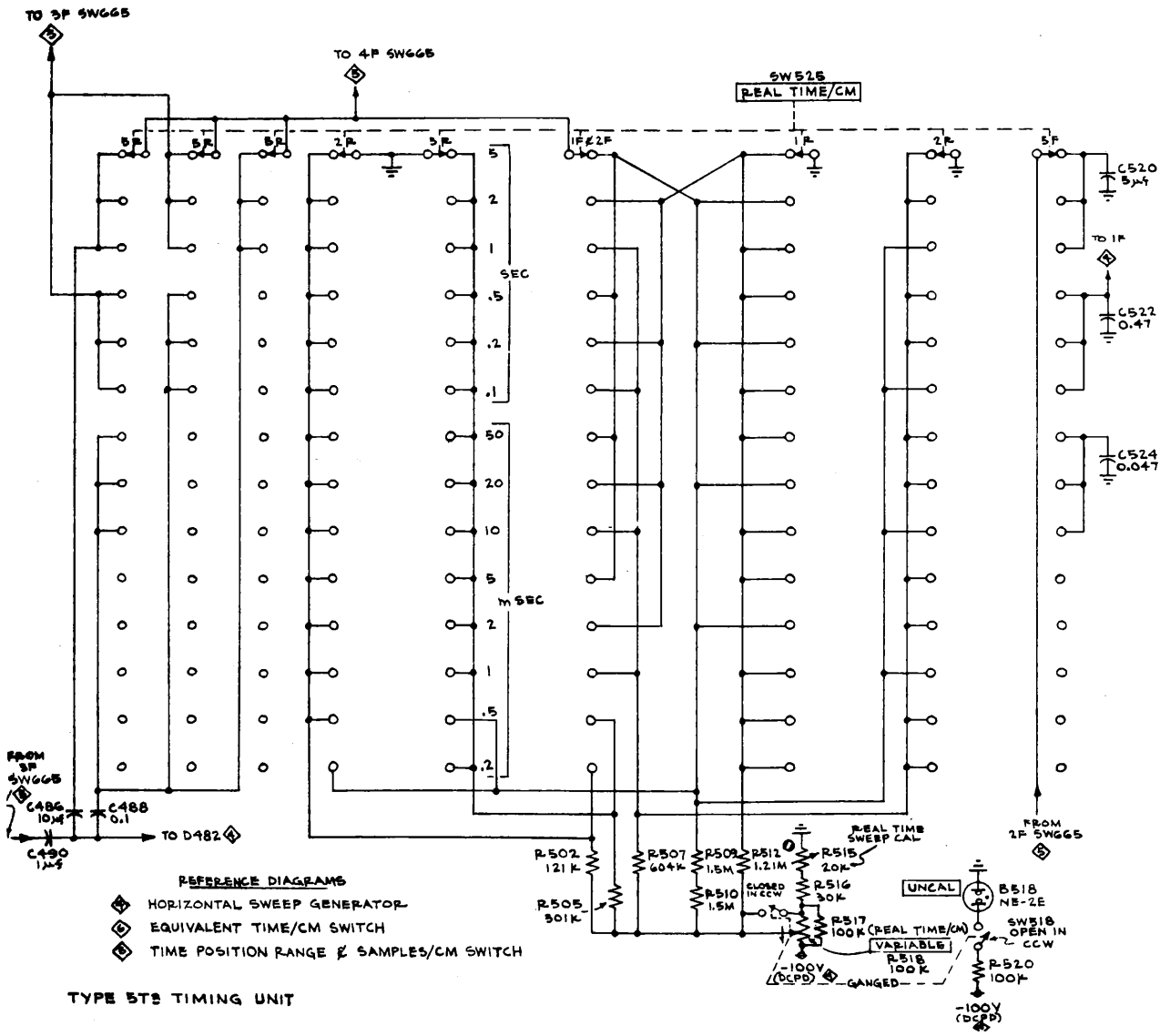

REAL TIME/CM SWITCH 01-11-65