

# **K4XL's BAMA**

This manual is provided **FREE OF CHARGE** from the "BoatAnchor Manual Archive" as a service to the Boatanchor community.

It was uploaded by someone who wanted to help you repair and maintain your equipment.

If you paid anyone other than BAMA for this manual, you paid someone who is making a profit from the free labor of others without asking their permission.

You may pass on copies of this manual to anyone who needs it. But do it without charge.

Thousands of files are available without charge from BAMA. Visit us at <http://bama.sbc.edu>

**Uploaded By:**  
**Jerry J. Ingordo**  
**W2JI**

# **INSTRUCTION MANUAL**

**TYPE 80 PLUG-IN  
and  
TYPE P80 PROBE**



## WARRANTY

All Tektronix instruments are warranted against defective materials and workmanship for one year. Tektronix transformers, manufactured in our own plant, are warranted for the life of the instrument.

Any questions with respect to the warranty mentioned above should be taken up with your Tektronix Field Engineer.

Tektronix repair and replacement-part service is geared directly to the field, therefore all requests for repairs and replacement parts should be directed to the Tektronix Field Office or Representative in your area. This procedure will assure you the fastest possible service. Please include the instrument Type and Serial number with all requests for parts or service.

Specifications and price change privileges reserved.

Copyright © 1961 by Tektronix, Inc., Beaverton, Oregon. Printed in the United States of America. All rights reserved. Contents of this publication may not be reproduced in any form without permission of the copyright owner.

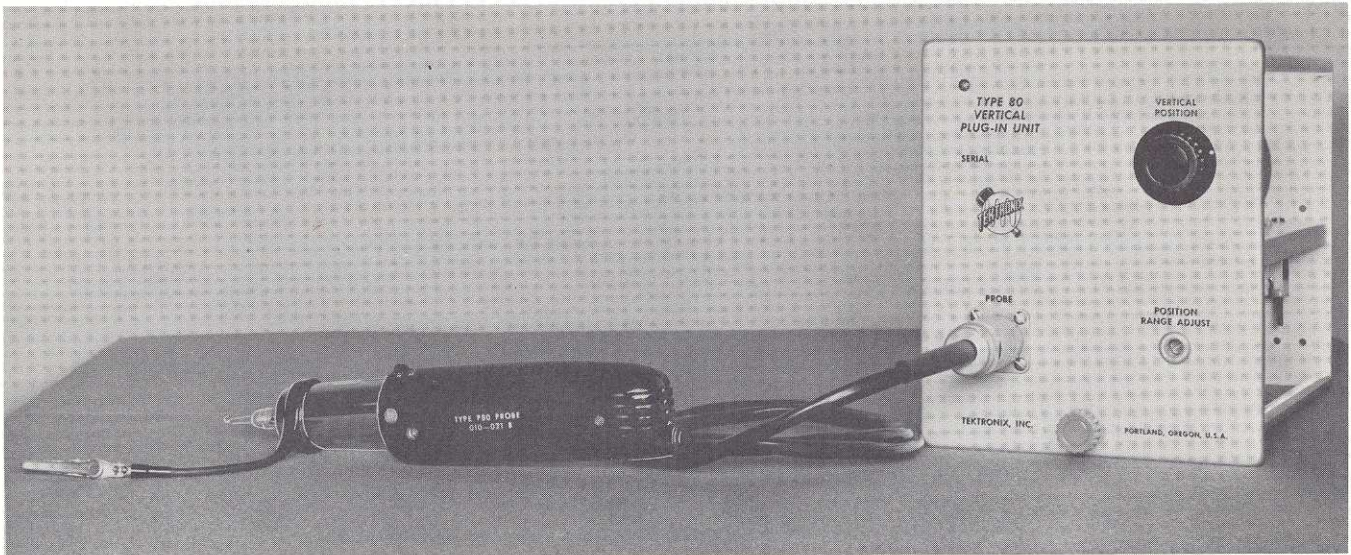

## TYPE 80 PLUG-IN UNIT AND TYPE P80 PROBE

### Operating Information-Type P80 Probe

#### General

The Type 80 Plug-In Unit and Type P80 probe are designed for operation with Tektronix 580-Series oscilloscopes. The Type P80 Probe provides the means for connecting a 580-series oscilloscope to the signal source. The probe can be connected to the signal source using one of the tips supplied. Or, if desired, special adaptors are available which allow direct connection of the probe to Type N, UHF, BNC, GR50 ohm and Tektronix 125 ohm connectors.

#### Characteristics

Risetime.....Typically 3.5 nanoseconds when the P80 and Type 80 are used with a Tektronix Type 581 or 585.

Bandpass.....dc to approximately 100 mc. (Approximately 3 db down at 100 mc when using a 25 ohm source.)

Typically, addition of attenuator heads causes no decrease in the risetime of the system.

#### Input Voltage

Maximum voltage with the AC-DC switch in the DC position is shown in the following table.

Maximum dc working voltage with the AC-DC switch in the AC position using the probe alone or with any attenuator is 150 V DC.

#### Input Signal Considerations

Input signals to the oscilloscope are connected to the input connector of the plug-in unit through the P80 probe. The gain of the vertical deflection system is accurately calibrated so that the vertical deflection factor at the input of the probe is 0.1 volts per centimeter when the probe is used with a Type 80 Plug-In Unit.

Attenuation of the input signal is accomplished by connecting an attenuator head onto the nose of the probe. Only a single attenuator head may be connected to the probe. If more attenuation is needed, Tektronix Standardized Attenuator Heads may be used. Two ratios of Standardized Head are available: X10 and X100.

To increase the attenuation using the Standardized head, determine which combination of Attenuator Head and Standardized Head will give the desired attenuation. Attach the Standardized Head to the P80 probe, then place the Attenuator head on the Standardized Head. Never place more than one Attenuator Head on the Standardized Head.

Table 7-1 lists the possible combinations of Standardized Heads and Attenuator Heads with other pertinent information.

The Input Selector switch on the body of the probe determines whether input waveforms are ac coupled or dc coupled to the oscilloscope input. AC coupling blocks the dc component of the input waveform and permits only the ac components to be applied to the oscilloscope. DC coupling permits both ac and dc components to be applied to the oscilloscope. AC coupling is used to eliminate large dc components which would cause the trace to be deflected off the screen. DC coupling should be used to prevent distortion of low frequency input waveforms.

### Operating Information-Type 80 Plug-In Unit

The VERTICAL POSITION control sets the position of the trace on the associated oscilloscope. Rotating the control clockwise moves the trace up. The control has sufficient range to position the trace off both the top and bottom of the screen.

#### WARNING

Whenever the Type P80 Probe or the Type 80 Plug-In Unit is replaced or used in a different instrument the Probe, Plug-In and Scope should be readjusted. Use the following procedure:

Table 7-1

Maximum Voltage Ratings of P80 Probe, Attenuator Heads  
Standardized Heads, and Capacitive Coupler

Configurations	Max- Allowable DC Voltage	Voltage required for 4 cm deflection DC *	Max E in		
			AC <sub>1</sub> **	AC <sub>2</sub> ***	AC <sub>3</sub> ****
P80 Probe	100 V	.4 V	150 V		
2-1 Att.	200 V	.8 V	150 V		
5-1 Att.	350 V	2.0 V	150 V		
10-1 Att.	500 V	4.0 V	150 V		
20-1 Att.	700 V	8.0 V	150 V		
50-1 Att.	1000 V	20.0 V	150 V		
100-1 Att.	1500 V	40.0 V	150 V		
2-1 Att. X 10 Stand.	200 V	8.0 V		250 V	
5-1 Att. X 10 Stand.	350 V	20.0 V		250 V	
10-1 Att. X 10 Stand.	500 V	40.0 V		250 V	
20-1 Att. X 10 Stand.	700 V	80.0 V		250 V	
50-1 Att. X 10 Stand.	1000 V	200.0 V		250 V	
100-1 Att. X 10 Stand.	1500 V	400.0 V		250 V	
2-1 Att. X 100 Stand.	200 V	80.0 V		250 V	
5-1 Att. X 100 Stand.	350 V	200.0 V		250 V	
10-1 Att. X 100 Stand.	500 V	400.0 V		250 V	
20-1 Att. X 100 Stand.	700 V	700.0 V (3.5 cm)		250 V	
50-1 Att. X 100 Stand.	1000 V	1000.0 V (2.0 cm)		250 V	
100-1 Att. X 100 Stand.	1500 V	1500.0 V (1.5 cm)		250 V	
Capacitive Coupler					600 v

- \* DC—Max DC with head and probe DC coupled
- \*\* AC<sub>1</sub>—Max DC with probe AC coupled
- \*\*\* AC<sub>2</sub>—Max DC with Standardized head AC coupled
- \*\*\*\* AC<sub>3</sub>—Max DC with Cap. Coupler

Input Capacitance and Resistance.

Typical values of the attenuators when attached to a probe or a standard attenuator head are shown in the following table.

Table 7-2

Attenuation	Input Capacitance	Input DC Resistance
2:1	7.8 pf.	200 k
5:1	3.3 pf.	500 k
10:1	2 pf.	1 megohm
20:1	1.4 pf.	2 megohms
50:1	3.7 pf.	5 megohms
100:1	1.4 pf.	10 megohms

Calibrating the Probe

1. Equipment

Tektronix Type 105 Square-Wave Generator or Equivalent.

Tektronix P-80—50 ohm Termination Adapter, Tektronix Part No. 013-033. Tektronix Alignment Tool Kit, Tektronix Part No. 003-007.

2. Terminate the OUTPUT of the Type 105 in the P-80—50 ohm Termination. Set the FREQUENCY of the Type 105 at 25 kc. Adjust the compensation of the Type P80 Probe for a flat-topped square wave.

3. To adjust the X10 or X100 Standards for the P80 Probe, carry out step 2 of this procedure. Next, put the 2:1 Attenuator Head on the probe. Reconnect to the Type 105 as in Step 2. Adjust the Attenuator Head Compensation for best response to the square wave.

Now, remove the 2:1 Attenuator Head. Put on the Standardized Head to be calibrated. Connect the 2:1 Attenuator Head in front of the Standardized Head. Reconnect to the Type 105 without the 50 Ω termination.

Adjust both compensations in the Standardized Head for the best response to the square wave.

Table 7-3

Input Capacitance of P80 Probe with Capacitive Coupler	
P80 and coupler.....	14 pf
100-1 Attenuator and coupler .....	8 pf
50-1 Attenuator and coupler .....	7.5 pf
20-1 Attenuator and coupler .....	5.4 pf
10-1 Attenuator and coupler .....	5.8 pf
5-1 Attenuator and coupler .....	7 pf
2-1 Attenuator and coupler .....	11 pf

Note: Use of a X100 or X10 Standardizer between probe and Attenuator Head will not change these values.

4. (This step may be omitted if only the probe is replaced or interchanged.) Set up the Type 105 for 250 kc output. Set the scope TIME/CM switch at 10  $\mu$ sec and adjust L8085 (accessible from bottom of Type 80) so the top of the square wave is parallel with the graticule lines. Readjust the probe compensation if necessary.

5. Connect the probe to the scope CAL. OUT. connector, and set the AMPLITUDE CALIBRATOR to .2 volt. Set TIME/CM switch to 500  $\mu$ sec, display the Calibrator signal and adjust the scope VERT. GAIN ADJ. (R1015) to provide 2 CM of vertical deflection.

### Circuit Operation

The Type P80 Probe is an anode-cathode-follower circuit which applies a split phase signal to the plug-in unit. Input signals are applied to the grid of V8013 through protective resistor R8011. This signal is then split in phase and amplified by a factor of less than 1. The signals obtained from the plate and cathode of V8013 are applied through toroid transformer T8013 and the interconnecting plug to the vertical amplifier of the associated oscilloscope. The toroid is used to equalize the cathode and anode signals. The waveform from the plate of V8013 is dc coupled to the oscilloscope to extend the response to dc. The cathode waveform is ac coupled to the oscilloscope.

Two controls affect the vertical position of the trace on the oscilloscope. The VERTICAL POSITION control is normally used to position the trace. The control adjusts the cathode voltage of the probe tube. This directly determines the current drawn by the tube and indirectly determines the vertical position of the trace.

The POSITION RANGE ADJUST control is used to insure that the VERTICAL POSITION control is in the proper range. A voltage regulator circuit consisting of V8044 and V8053A supplies screen grid voltage for the probe tube. The output voltage of the regulator is set with the POSITION RANGE ADJUST control. By varying the screen voltage of the tube, the plate current can also be changed. This in turn allows the vertical position of the trace to be varied over a wide range.

A circuit consisting of L8085, R8085, C8085, and R8077 is used to maintain the proper terminating impedance for the coaxial cable from the cathode of the probe tube. The dc resistance of L8085 is 13 ohms making the impedance of L8085 and R8085 93 ohms to ground at dc. This provides the proper termination at low frequencies. At high frequencies the correct termination is provided by R8077 and C8085. The series combination of L8085 is effectively out of the circuit at high frequencies because of the reactance of L8085. At intermediate frequencies the proper termination is obtained by C8085 and R8077 being effectively in parallel with L8085 and R8085.

The circuits associated with V8053B provide the terminations for the grid line of the oscilloscope vertical amplifier. Resistors R8075 and R8077 provide the required 93-ohm terminations. Cathode follower V8053B sets the voltage of the grid lines at approximately 50 volts and provides the plate voltage for the probe through the vertical amplifier grid line. Without additional circuits plate current would flow through R8071 and R8075 to the probe. This current flow would produce a voltage drop which would cause the two grid lines to be at slightly different potentials. Resistors R8073, R8074, R8071, R8077, and R8078 are used to maintain the two grid lines at the same voltage. Current flowing through R8071 and R8075 due to this circuit is approximately equal but opposite in direction to the plate current that would flow from the probe. This effectively eliminates the voltage drop produced by the plate current and insures that the two grid lines are at the same potential.

## P-80 Standard Accessories

DESCRIPTION		PART NO.
GROUND LEAD		175-063
CLIP ASSEMBLY		344-055
HOOK TIP		206-008
STRAIGHT TIP		206-009
HIGH FREQUENCY GROUND CLIP		013-047
PROBE HOLDER		352-030
ATTENUATOR HEADS	X2	010-306
	X5	010-307
	X10	010-308
	X20	010-309
	X50	010-310

## P-80 OPTIONAL ACCESSORIES

X10 Standard	010-311
X100 Standard	010-321
Capacitor Coupler	010-312
Attenuator 100:1	010-322
Adapter, Probe to Type "N" Connector	010-016
Adapter, Probe to Type "UHF" Connector	013-017
Adapter, Probe to Type "BNC" Connector	013-018

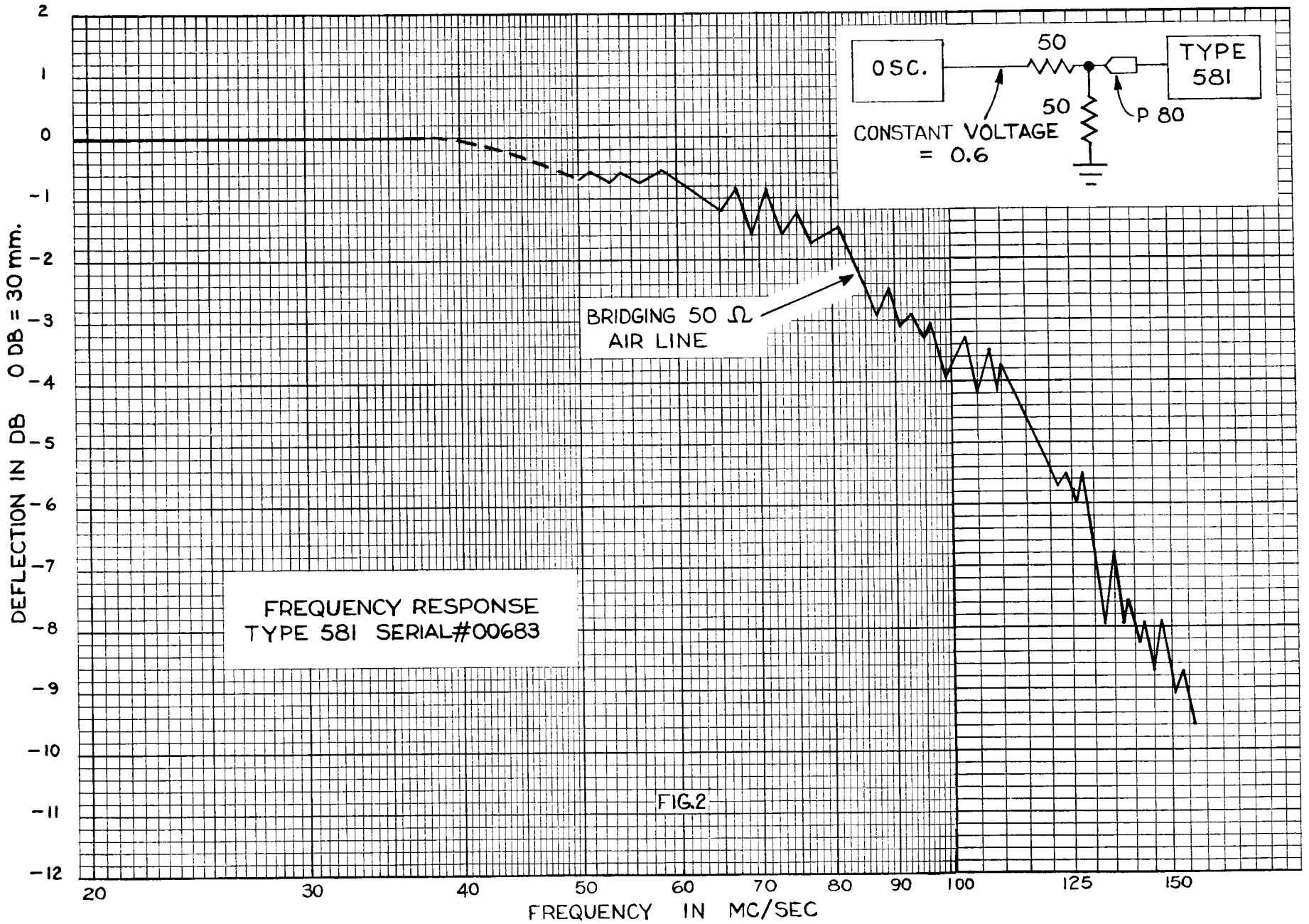



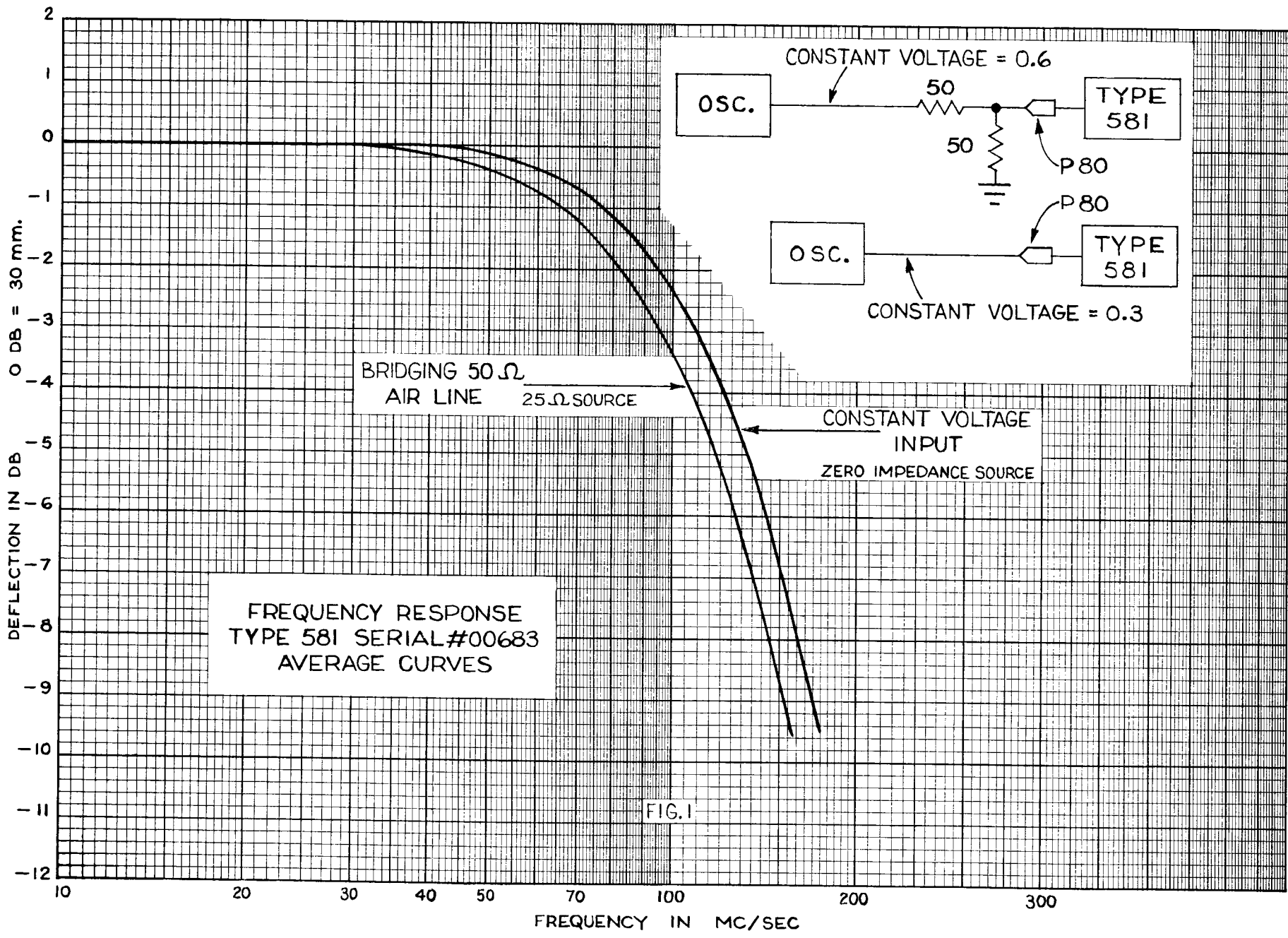

# PARTS LIST *and* DIAGRAMS

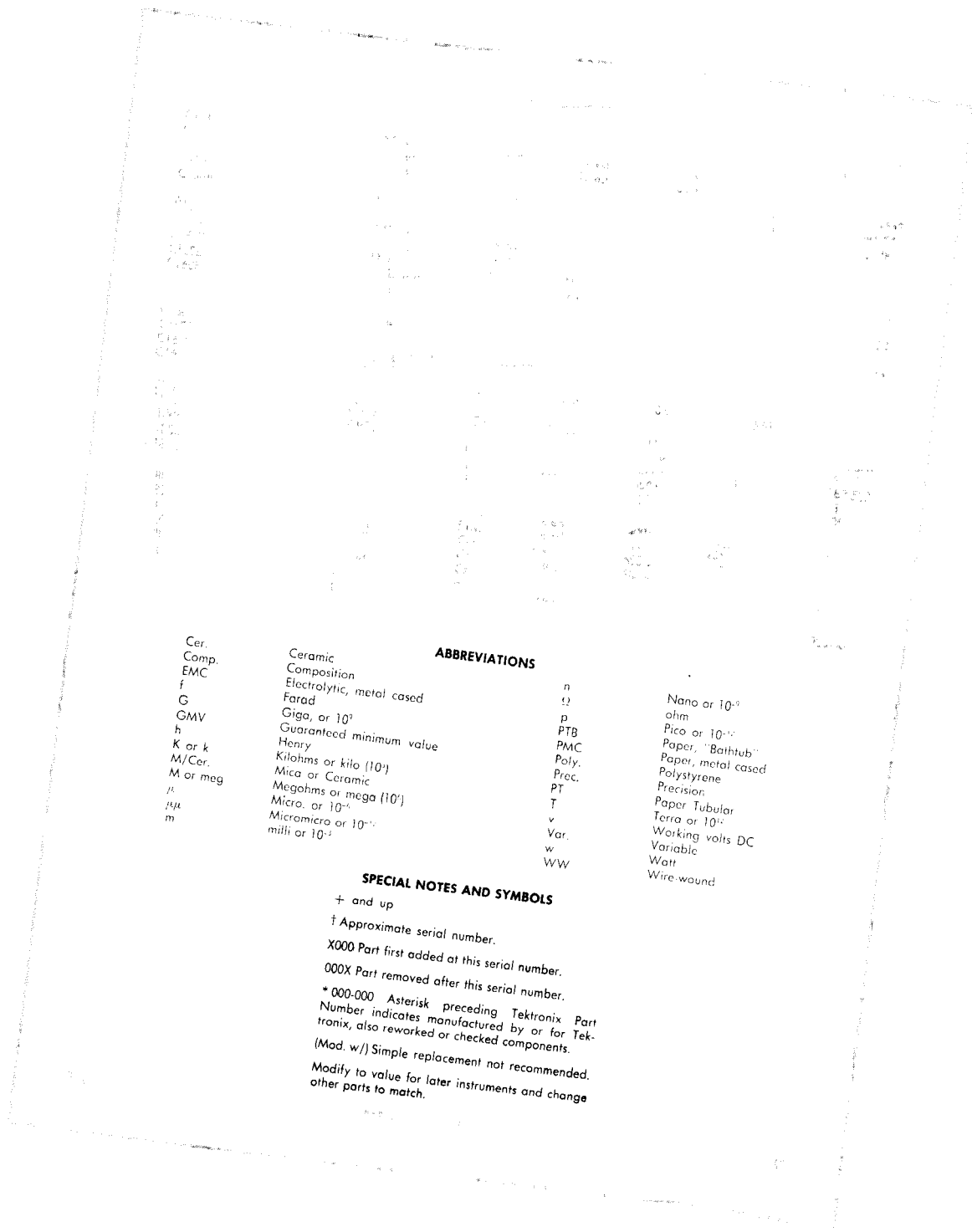

Cer.  
 Comp.  
 EMC  
 f  
 G  
 GMV  
 h  
 K or k  
 M/Cor.  
 M or meg  
 $\mu$   
 $\mu$   
 m

Ceramic  
 Composition  
 Electrolytic, metal cased  
 Farad  
 Giga, or  $10^9$   
 Guaranteed minimum value  
 Henry  
 Kilohms or kilo ( $10^3$ )  
 Mica or Ceramic  
 Megohms or mega ( $10^6$ )  
 Micro, or  $10^{-6}$   
 Micromicro or  $10^{-12}$   
 milli or  $10^{-3}$

### ABBREVIATIONS

n  
 $\Omega$   
 p  
 PTB  
 PMC  
 Poly.  
 Proc.  
 PT  
 T  
 v  
 Var.  
 w  
 WW  
 Nano or  $10^{-9}$   
 ohm  
 Pico or  $10^{-12}$   
 Paper, "Bathtub"  
 Paper, metal cased  
 Polystyrene  
 Precision  
 Paper Tubular  
 Terra or  $10^{12}$   
 Working volts DC  
 Variable  
 Watt  
 Wire-wound

### SPECIAL NOTES AND SYMBOLS

+ and up  
 † Approximate serial number.  
 X000 Part first added at this serial number.  
 000X Part removed after this serial number.  
 \* 000-000 Asterisk preceding Tektronix Part Number indicates manufactured by or for Tektronix, also reworked or checked components.  
 (Mod. w/) Simple replacement not recommended.  
 Modify to value for later instruments and change other parts to match.



## **HOW TO ORDER PARTS**

Replacement parts are available through your local Tektronix Field Office.

Improvements in Tektronix instruments are incorporated as soon as available. Therefore, when ordering a replacement part it is important to supply the part number including any suffix, instrument type, serial number, plus a modification number where applicable.

If the part you have ordered has been improved or replaced, your local Field Office will contact you if there is a change in part number.

# PARTS LIST

## TYPE P80 PROBE AND TYPE 80 PREAMPLIFIER

Values are fixed unless marked variable.  
Tolerance  $\pm 20\%$  unless otherwise indicated.

### Capacitors

Circuit No.	Tektronix Part No.		Description				Serial No.
C8010†	283-003	.01 $\mu$ f	Cer.	Fixed	150 v		
C8011†	283-003	.01 $\mu$ f	Cer.	Fixed	150 v		
C8013†	283-004	.02 $\mu$ f	Cer.	Fixed	150 v		
C8014†	283-000	.001 $\mu$ f	Cer.	Fixed	500 v		
C8016 †	281-541	6.8 $\mu$ $\mu$ f	Cer.	Fixed	500 v	10%	
C8016 †	281-504	10 $\mu$ $\mu$ f	Cer.	Fixed	500 v	1/8% 101-3386 3387-up	
C8041	285-510	.01 $\mu$ f	PTM	Fixed	400 v		
C8053A,B	290-037	2 x 20 $\mu$ f	EMC	Fixed	450 v		
C8071	**295-061	.01 $\mu$ f	MT	Fixed	200 v		
C8073	283-006	.02 $\mu$ f	Cer.	Fixed	600 v		
C8085	**295-061	.01 $\mu$ f	MT	Fixed	200 v		
C8086	281-010	4.5-25 $\mu$ $\mu$ f	Cer.	Var.		X3387-up	
C8088	281-022	8-50 $\mu$ $\mu$ f	Cer.	Var.		X3387-up	

### Resistors

R8010†	318-001	100 k	1/8 w	Fixed	Prec.	1%	
R8011†	316-104	100 k	1/4 w	Fixed	Comp.	10%	
R8012†	317-220	22 $\Omega$	1/10 w	Fixed	Comp.	5%	
R8016†	317-100	10 $\Omega$	1/10 w	Fixed	Comp.	5%	
R8017†	316-151	150 $\Omega$	1/4 w	Fixed	Comp.	10%	
R8018†	311-150	500 $\Omega$	1/10 w	Var.	Comp.		
R8040	309-052	220 k	1/2 w	Fixed	Prec.	1%	
R8041	311-026	100 k	2 w	Var.	Comp.		
R8042	309-109	250 k	1/2 w	Fixed	Prec.	1%	
R8044	302-155	1.5 meg	1/2 w	Fixed	Comp.	10%	
R8047	302-473	47 k	1/2 w	Fixed	Comp.	10%	
R8048	302-473	47 k	1/2 w	Fixed	Comp.	10%	
R8050	302-102	1 k	1/2 w	Fixed	Comp.	10%	
R8053	308-024	15 k	10 w	Fixed	WW	5%	
R8054	302-104	100 k	1/2 w	Fixed	Comp.	10%	
R8056	309-090	50 k	1/2 w	Fixed	Prec.	1%	
R8057	309-090	50 k	1/2 w	Fixed	Prec.	1%	
R8060	302-101	100 $\Omega$	1/2 w	Fixed	Comp.	10%	
R8071	***312-597	93.1 $\Omega$	1/2 $\Omega$	Fixed	Checked	1%	
R8073	302-101	100 $\Omega$	1/2 w	Fixed	Comp.	10%	
R8074	302-103	10 k	1/2 w	Fixed	Comp.	10%	101-1949
R8074	309-228	12.5 k	1/2 w	Fixed	Prec.	1%	1950-up
R8075	***312-597	93.1 $\Omega$	1/2 $\Omega$	Fixed	Checked	1%	
R8077	***312-597	93.1 $\Omega$	1/2 $\Omega$	Fixed	Checked	1%	
R8078	302-103	10 k	1/2 w	Fixed	Comp.	10%	101-1949
R8078	309-100	10 k	1/2 w	Fixed	Prec.	1%	1950-up
R8080	311-074	5 k	.1 w	Var.			X3387-up
R8081	311-016	10 k	2 w	Var.	Comp.		
R8082	302-741	470 $\Omega$	1/2 w	Fixed	Comp.	10%	X3387-up
R8083	306-103	10 k	2 w	Fixed	Comp.	10%	

†Located in probe.

\*\*\* Checked to .1% of each other—furnished as a unit.

\*\* Checked to 1% of each other.

**Resistors (continued)**

Circuit No.	Tektronix Part No.	Description					Serial No.
R8084	306-103	10 k	2 w	Fixed	Comp.	10%	101-3386 3387-up X3387-up X3387-up
R8085	309-184	80 $\Omega$	1/2 w	Fixed	Prec.	1/4%	
R8085	309-226	93.1 $\Omega$	1/2 w	Fixed	Prec.	1%	
R8086	311-010	2.5 k	.1 w	Var.			
R8088	302-332	3.3 k	1/2 w	Fixed	Comp.	10%	
R8089	308-123	20 $\Omega$	5 w	Fixed	WW	5%	

**Vacuum Tubes**

V8013†	154-215	6688/E180F
V8044	154-022	6AU6
V8053	154-187	6DJ8/ECC88

**Transformer**

T8013†	*120-132	Toroid
--------	----------	--------

**Inductors**

L8085	Use *114-131	60-105 $\mu$ h	Var.
-------	--------------	----------------	------

**Switch**

SW8010†	*260-286	AC-DC
---------	----------	-------

† Located in probe.

# Type 80 Mechanical Parts List

	Tektronix Part Number
BUSHING, $\frac{3}{8}$ -32 x $\frac{9}{16}$ x .412	358-010
CABLE HARNESS	179-343
CHASSIS	441-266
CONNECTOR, CHAS. MT. 16 CONT. MALE	131-017
EYELET, TAPERED BARREL	210-601
GROMMET, RUBBER $\frac{5}{16}$	348-003
KNOB, LARGE BLACK, $\frac{1}{4}$ HOLE PART WAY	366-042
KNOB, PLUG-IN SECURING $\frac{9}{16}$ x $\frac{5}{8}$	366-125
LOCKWASHER, INT. #4	210-004
LOCKWASHER, INT. #6	210-006
LOCKWASHER, POT. INT. $\frac{3}{8}$ x $\frac{1}{2}$	210-012
LOCKWASHER, POT. INT. $\frac{3}{8}$ x $1\frac{1}{16}$	210-013
LUG, SOLDER SE4	210-201
LUG, SOLDER, POT PLAIN $\frac{3}{8}$	210-207
NUT, HEX 6-32 x $\frac{5}{16}$	210-406
NUT, HEX 6-32 x $\frac{1}{4}$	210-407
NUT, HEX $\frac{3}{8}$ -32 x $\frac{1}{2}$	210-413
NUT, HEX 6-32 x $\frac{5}{16}$ x .194 5-10 W RES. MTG.	210-478
NUT, HEX $\frac{3}{8}$ -32 x $\frac{1}{2}$ x $1\frac{1}{16}$	210-494
PANEL, FRONT	333-536
PLATE, SUB-PANEL	386-926
PLATE, $5\frac{1}{32}$ x $6\frac{1}{32}$	387-529
RING, RETAINING, #18 SECURING	354-025
ROD, FRAME $\frac{3}{8}$ x $8\frac{7}{8}$ TAPPED 8-32 BOTH ENDS	384-508
ROD, SECURING $\frac{3}{16}$ x $10\frac{1}{2}$ 10-24 THREADED ONE END	384-510
SCREW, 4-40 x $\frac{5}{16}$ BHS	211-011
SCREW, 4-40 x $\frac{3}{8}$ BHS	211-012
SCREW, 4-40 x $\frac{5}{16}$ PHS W/LOCKWASHER	211-033
SCREW, 6-32 x $\frac{5}{16}$ BHS	211-507
SCREW, 6-32 x $\frac{3}{8}$ BHS	211-510
SCREW, 6-32 x $\frac{5}{16}$ PHS W/LOCKWASHER	211-534
SCREW, 6-32 x $1\frac{1}{2}$ RHS, PHILLIPS	211-553
SCREW, 6-32 x $\frac{3}{8}$ FHS 100°, CSK, PHILLIPS	211-559

**Mechanical Parts List** (continued)

	Tektronix Part Number
SCREW, 8-32 x 1/2 FHS 100°, PHILLIPS	212-043
SCREW, 8-32 x 1/2 FHS 100°	212-044
SOCKET, STM7G	136-008
SOCKET, STM9G	136-015
SOCKET, 9 PIN CHAS. W/MALE INSERT	136-077
SPACER, NYLON MLD. 3/8 FOR CERAMIC STRIP	361-009
STRIP, CERAMIC 3/4 x 7 NOTCHES, CLIP MTD.	124-089
STRIP, CERAMIC 3/4 x 11 NOTCHES, CLIP MTD.	124-091
WASHER, STEEL .390 x 7/16 x .020	210-840
WASHER, POLYETHYLENE .190 x 7/16 x 1/32	210-894

REGULATED SUPPLY FOR  
V8013 SCREEN GRID

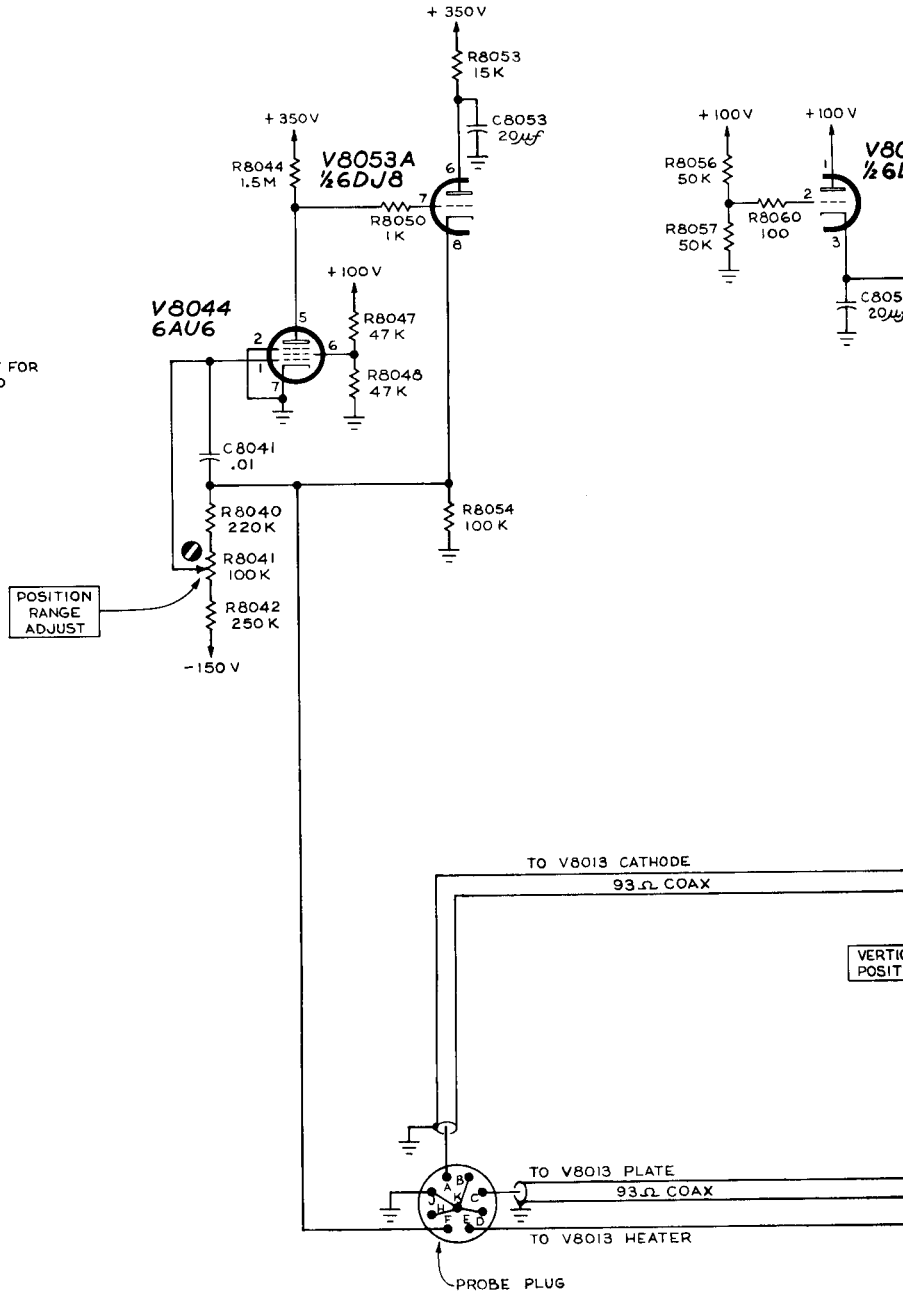

+



+

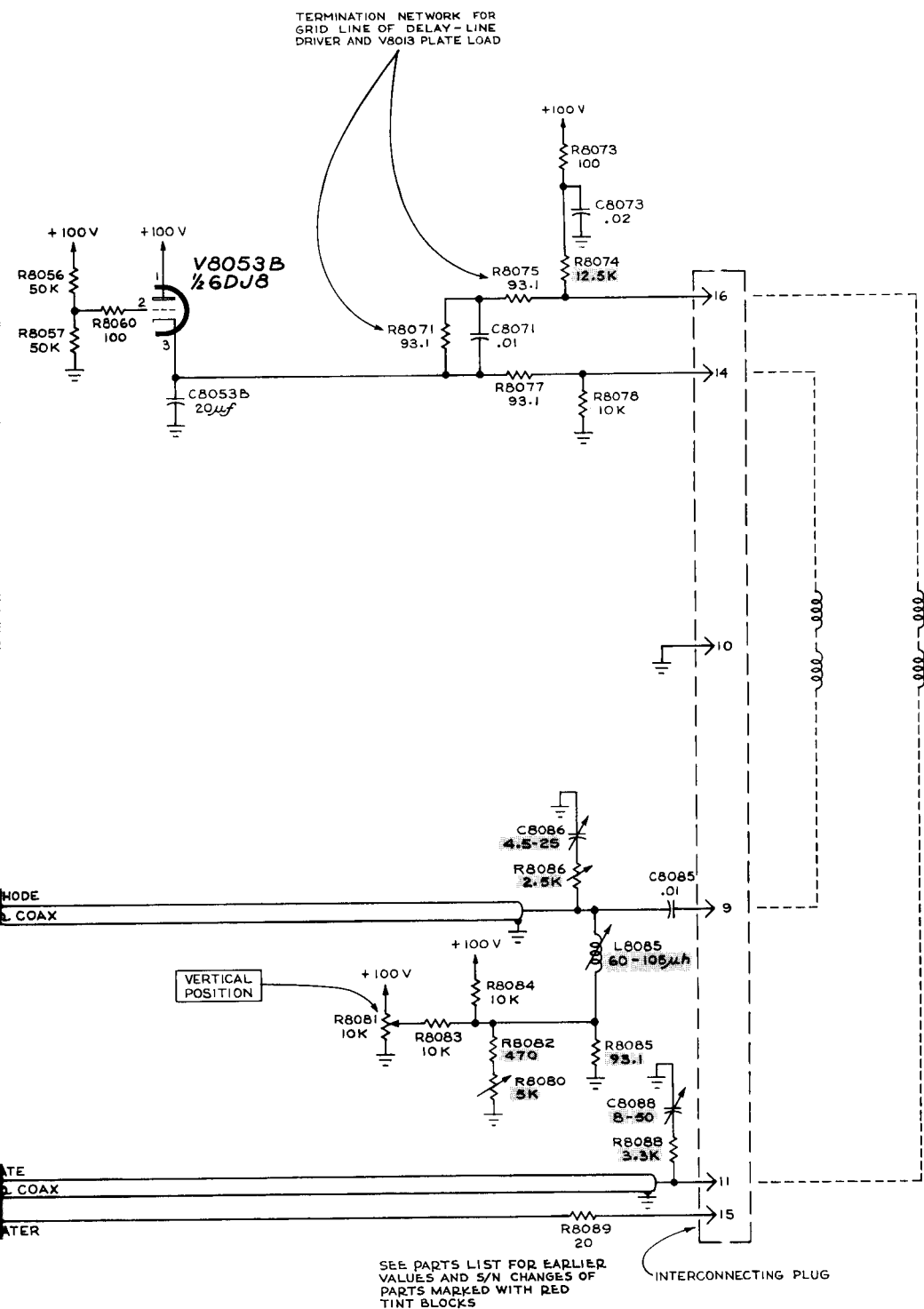

3-22-62  
24L

TYPE 80 PLUG-IN UNIT

AA

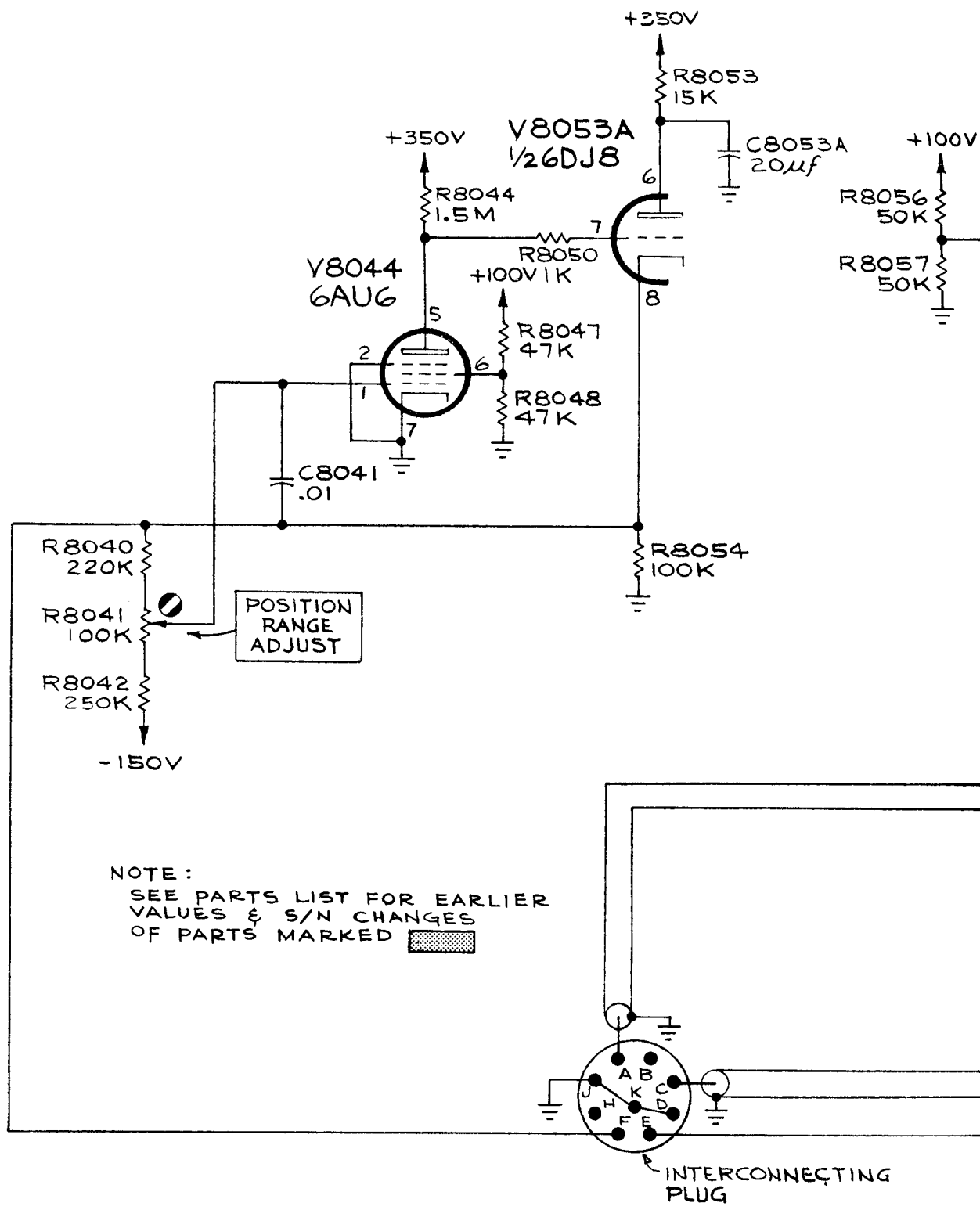

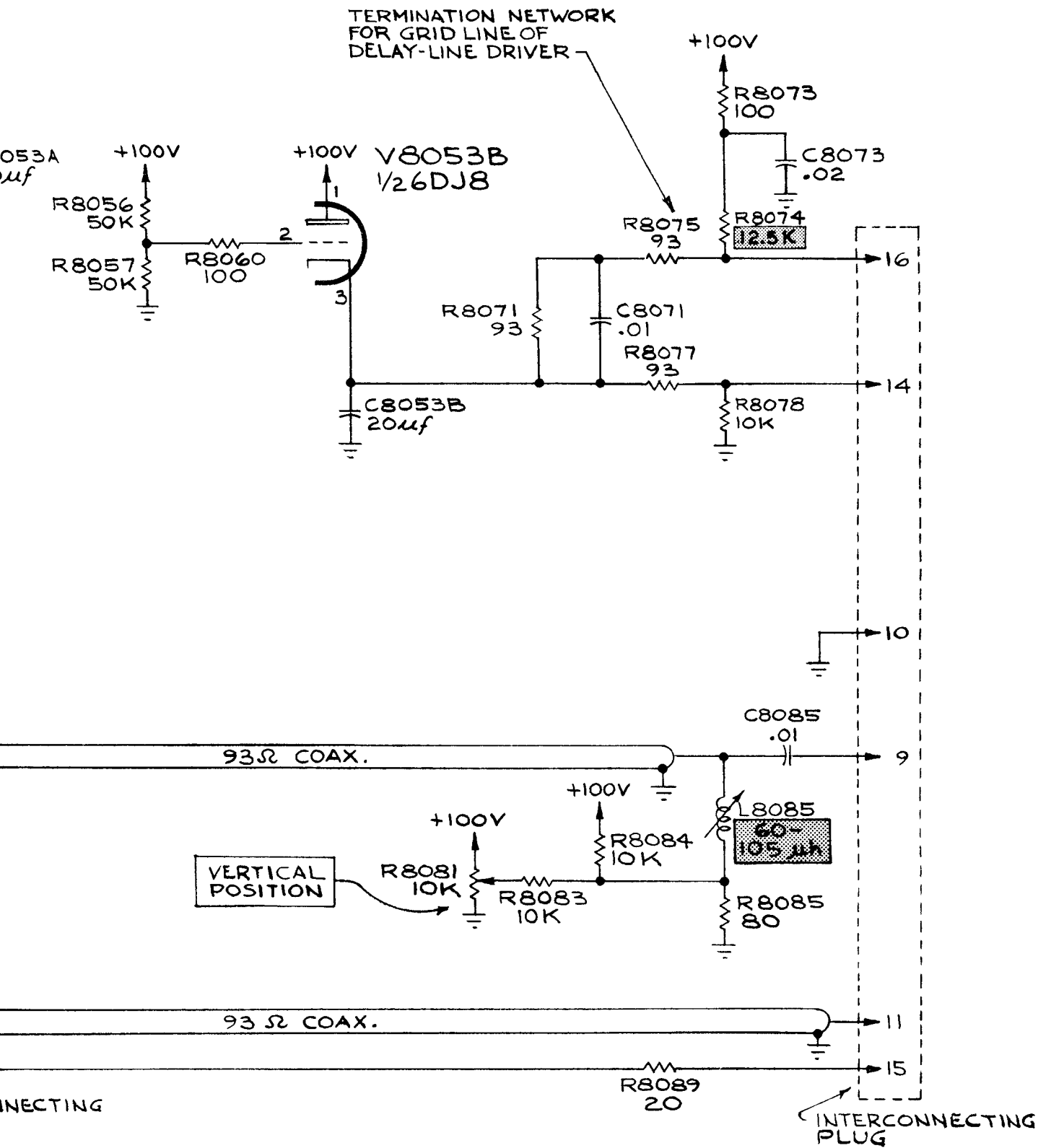

MH  
7-13-61

TYPE 80 PLUG-IN UNIT

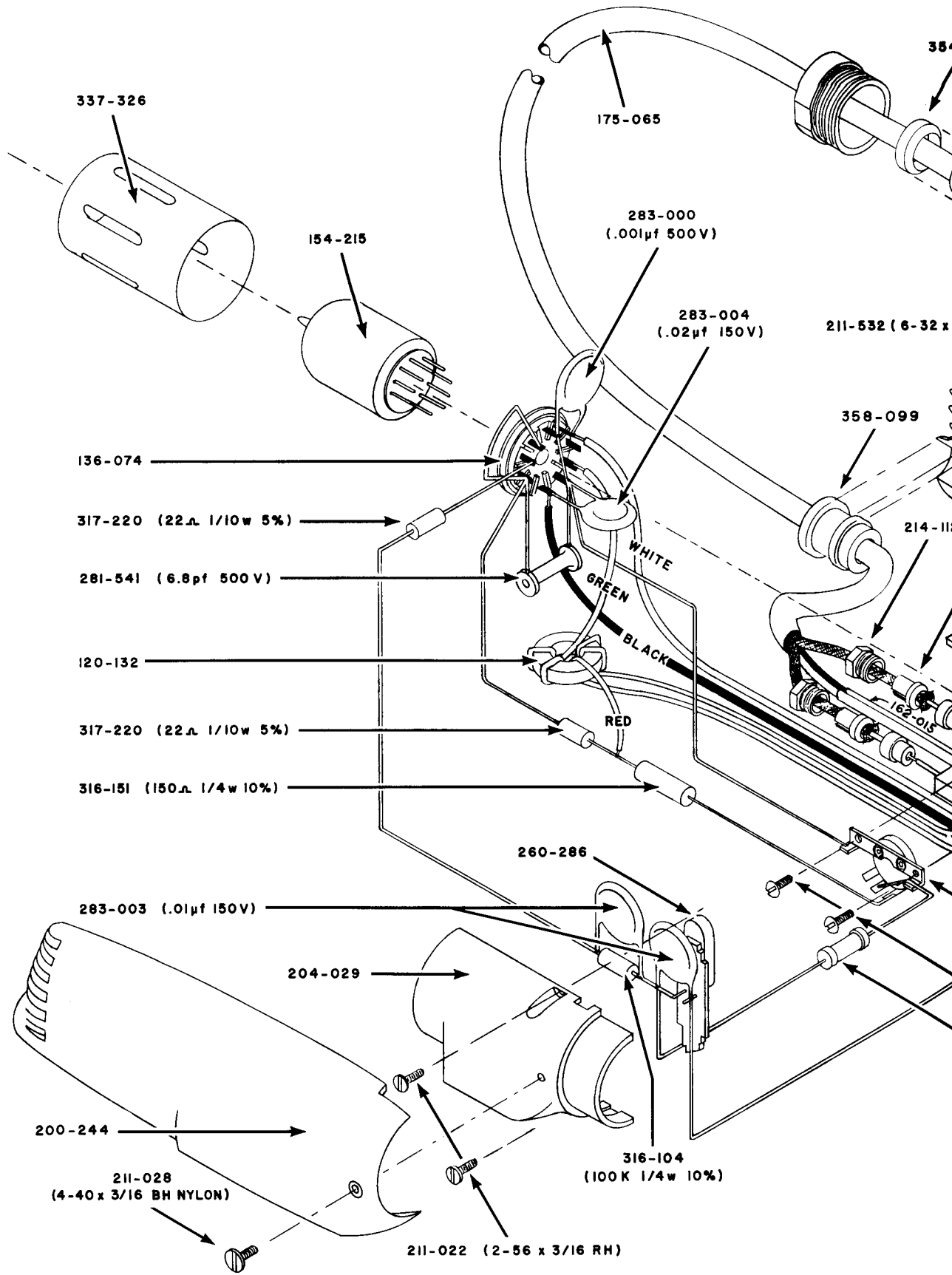

A

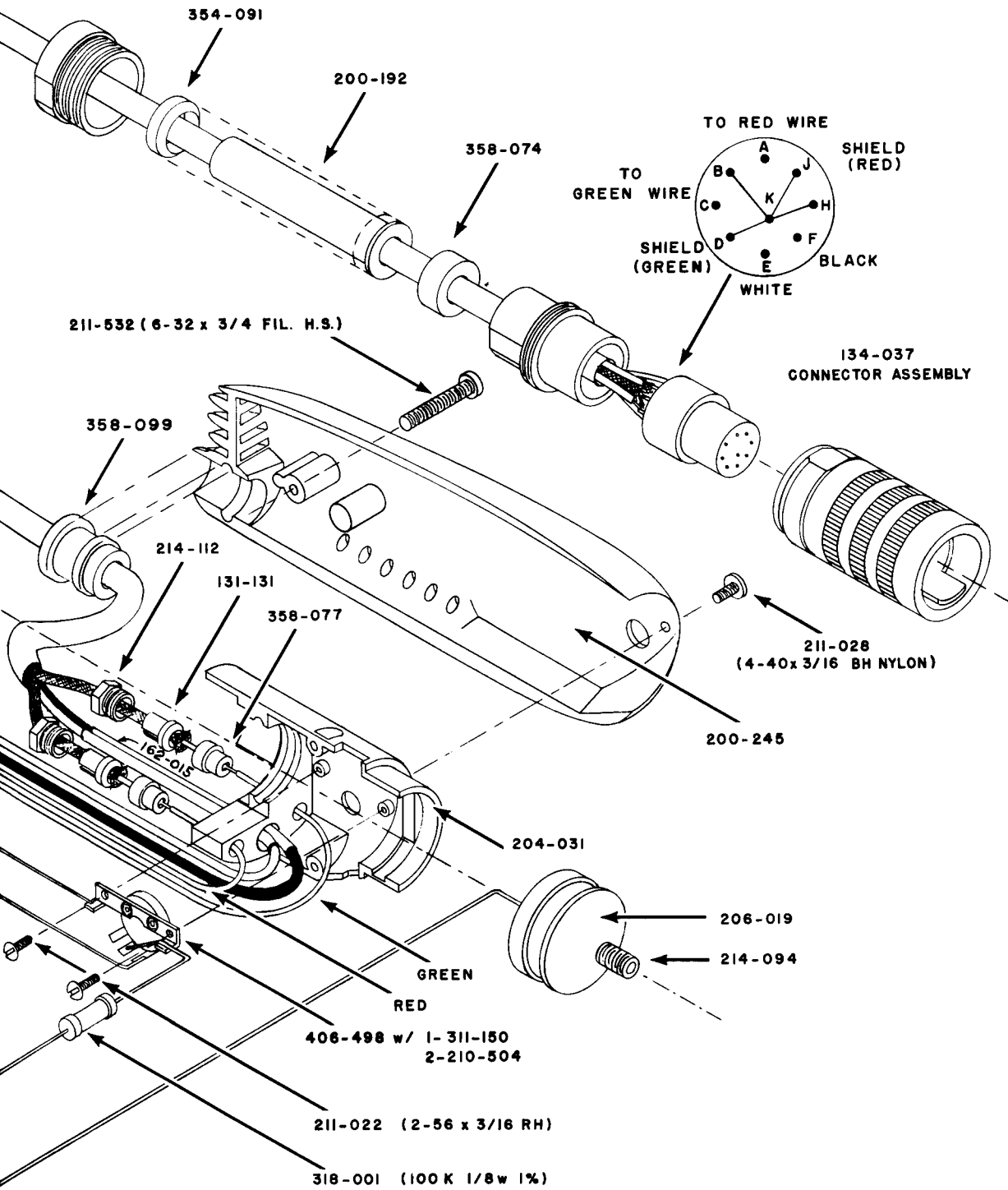

A

TYPE P-80 PARTS

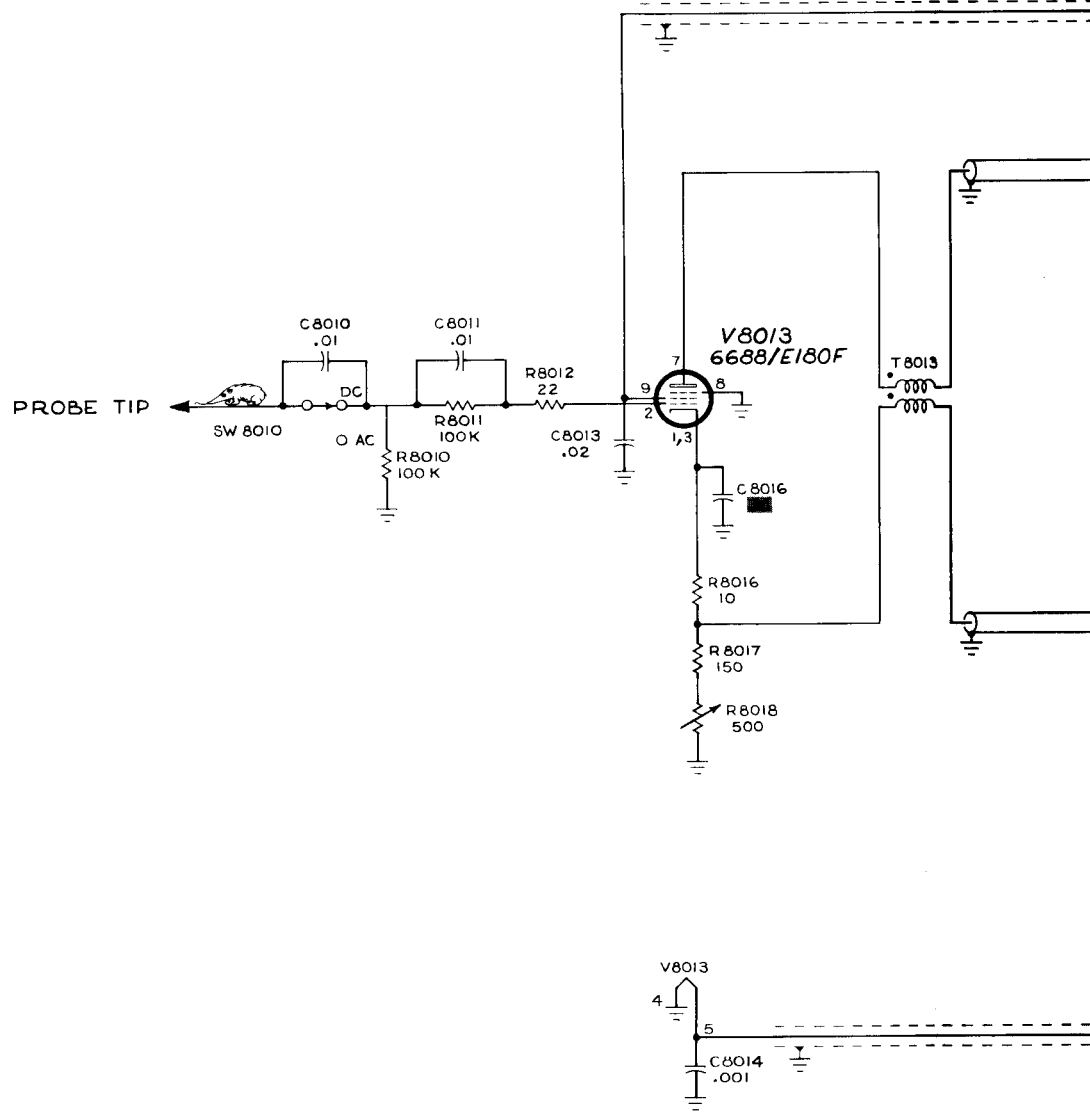

+

C<sub>2</sub>

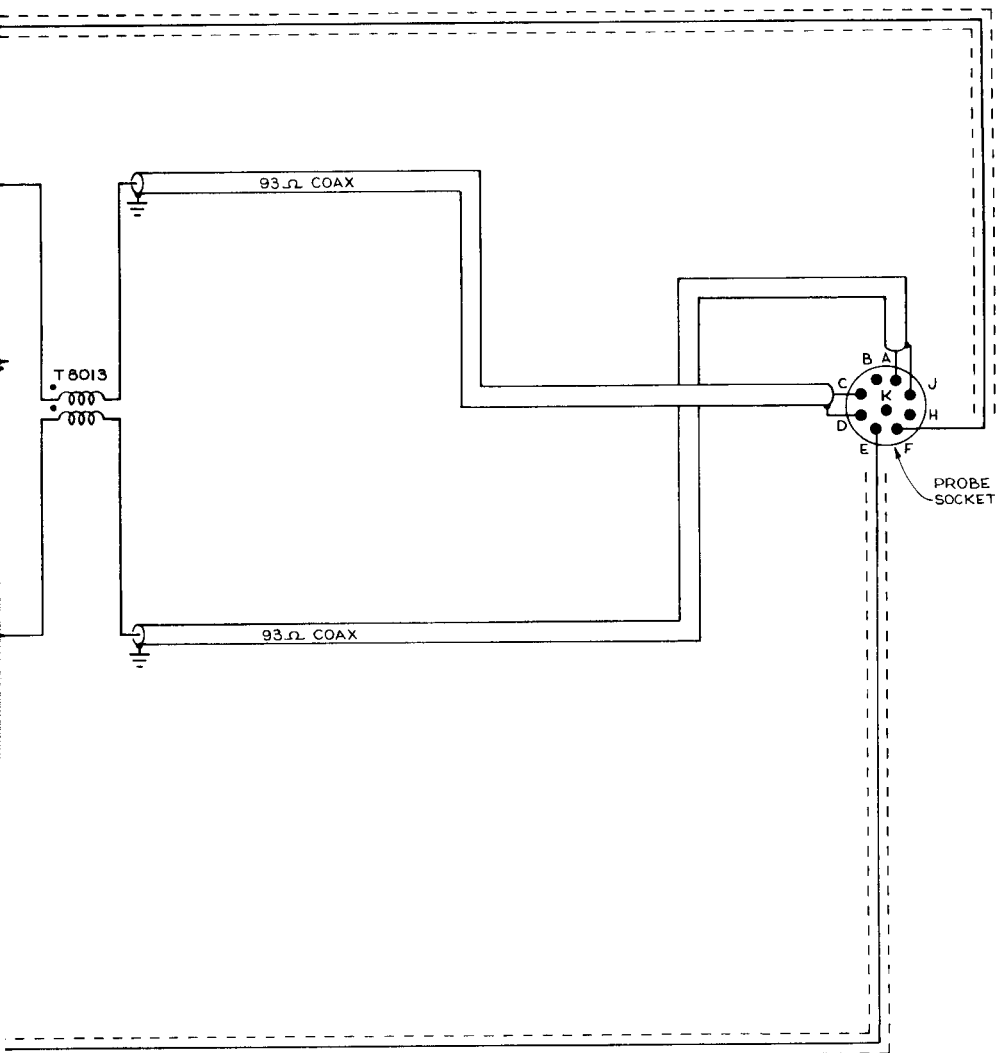

SEE PARTS LIST FOR EARLIER  
VALUES AND S/N CHANGES OF  
PARTS MARKED WITH RED  
TINT BLOCKS

9 - 19 - 61

ML

TYPE 80 PROBE

C<sub>2</sub>

TYPE 80 Plug-In  
and 80 Probe  
Correction to page 4

Adapter Probe to Type "N" Connector should read 013-016.



TYPE 80 PROBE  
TYPE 80 PLUG-IN  
MOD 5107

Replace the calibration procedure in the manual with the following:

Equipment Required

The following equipment, or its equivalent is required to check the calibration of the Type 80 probe and plug-in.

1. Tektronix Type 581 or 585 oscilloscope.
2. Tektronix Type 105 Square-Wave Generator.
3. Tektronix Type 109 Pulse Generator with 40 to 60 nanoseconds of charge line attached.
4. Type 80 probe to G.R. -50ohm adapter. Tektronix part number 013-035.
5. Alignment tool, Tektronix part number 003-000.

1. Preliminary

Before installing the Type 80 into the oscilloscope, make a careful visual inspection of the unit. This is particularly important if any soldering has been done.

Preset C8086 10 degrees from its minimum capacitance point. All other variable capacitors and potentiometers in both the plug-in and probe should be set to mid-range.

Now make the following resistance-to-ground checks at the 16-pin interconnecting plug. The table lists the nominal resistance value from each pin to ground.

PIN NUMBER	RESISTANCE-TO-GROUND
1	200k $\Omega$
2	3k $\Omega$
3	infinite
4	200k $\Omega$
5	infinite
6	infinite
7	infinite
8	infinite
9	infinite
10	0
11	infinite

12	infinite
13	infinite
14	6.2k $\Omega$
15	23 $\Omega$
16	6.2k $\Omega$

## 2. POSITION RANGE ADJUST

Set up the oscilloscope for a free running trace. Now with the VERTICAL POSITION control centered mechanically, adjust the POSITION RANGE ADJUST until the trace is superimposed on the center horizontal graticule line.

DO NOT move the VERTICAL POSITION control through out the remainder of this calibration procedure.

## 3. Low Frequency Compensation Adjustments

Connect the Type 80 probe to the Type 105 Square-Wave Generator and adjust the generator for a 10kc output approximately 2 cm high. If repositioning of the trace is necessary do it with the POSITION RANGE ADJUST.

The triggering circuit of the oscilloscope should be set to + INT and the controls adjusted for a stable display. The TIME/CM switch will have to be at .5msec and 50 $\mu$ sec to view the waveform for any rolloff or overshoot of the front corner of waveform. The 50 $\mu$ sec rate will let you check the overall level of the waveform.

Now adjust R8018, in probe R8080 and L8085 for minimum spike or rolloff and for the best level on the top of the waveform.

## 4. Adjustment of High-Frequency Compensations

Connect the Type 80 probe through the 50 ohm termination to the 109. The sweep rate of the oscilloscope should be set to .05 $\mu$ sec/cm with the magnifier off. The AC-DC switch on the 80 probe should be set to AC.

Now adjust R8086 until the leading edge of the waveform equals the average level of the waveform then with C8086 adjust the level of the first centimeter of waveform to equal the average level.

Recheck R8018 and R8080. They interact with the high-frequency compensations.

TYPE 581  
 TYPE 585  
 TYPE 80 PROBE  
 TYPE 80 PLUG-IN  
 MOD. 5107

CAPACITORS

C1006	add	3-12 pf	cer.	var.		281-036
C1075	removed					
C1204	change to	.01 $\mu$ fd	cer,	fixed	150v	283-003
C1205	change to	.1 $\mu$ fd	cer.	fixed	10v	283-032
C1209	add	8-50 pf	cer.	var.		281-022
C1255	add	1.8 pf	cer.	fixed	500v	281-557
C1261	change to	.7-3 pf	tub.	var.		281-027
C8086	add	4.5-25 pf	cer.	var.		281-010
C8088	add	8-50 pf	cer.	var.		281-022

COILS

L914	change to	Delay Line				108-246
L1280	change to	.1 $\mu$ h		fixed		108-250
L1281	change to	.1 $\mu$ h		fixed		108-250
L1286	change to	.45 $\mu$ h		fixed		108-221
L1287	change to	.45 $\mu$ h		fixed		108-221

RESISTORS

R1007	add	15 $\Omega$	1/2w	comp	10%	302-150
R1008	change to	78 $\Omega$	1/2w	prec.	1%	309-172
R1009	change to	78 $\Omega$	1/2w	prec.	1%	309-172
R1011	add	60 $\Omega$	1/2w	prec.	1%	309-067
R1012	add	60 $\Omega$	1/2w	prec.	1%	309-067
R1204	change to	4 $\Omega$	1/2w	prec.	1%	309-060
R1205	change to	3 $\Omega$	1/2w	prec.	1%	309-059
R1208	change to	60 $\Omega$	1/2w	prec.	1%	309-067
R1209	change to	60 $\Omega$	1/2w	prec.	1%	309-067
R1211	change to	1.8k	1/2w	prec.	1%	309-030
R1212	add	40 $\Omega$	1/2w	prec.	1%	309-066
R1214	add	40 $\Omega$	1/2w	prec.	1%	309-066
R1260	add	15 $\Omega$	1/4w	comp.	10%	316-150
R1286	change to	156 $\Omega$	1/2w	prec.	1%	309-175
R1287	change to	156 $\Omega$	1/2w	prec.	1%	309-175
R1288	add	156 $\Omega$	1/2w	prec.	1%	309-175
R1289	add	156 $\Omega$	1/2w	prec.	1%	309-175

R1290	add	180 $\Omega$	1/2w	prec.	1%	309-072
R1291	add	180 $\Omega$	1/2w	prec.	1%	309-072
R1292	add	470 $\Omega$	1/2w	comp.	10%	302-471
R1293	add	5k	.1w	var.		311-074
R8080	add	5k	.1w	var.		311-074
R8085	add	93.1 $\Omega$	1/2w	prec.	1%	309-266
R8086	add	2.5k	.1w	var.		311-010
R8088	add	3.3k	1/2w	comp.	10%	302-332

### Supplement to Mod 5107

Add the following to the insert parts list:

C1214	change to	.7-3pf	tub	var		281-027
C8016	change to	10pf	cer	fixed		281-504
R1207	add	Selected Nominal value		15 $\Omega$		302-150

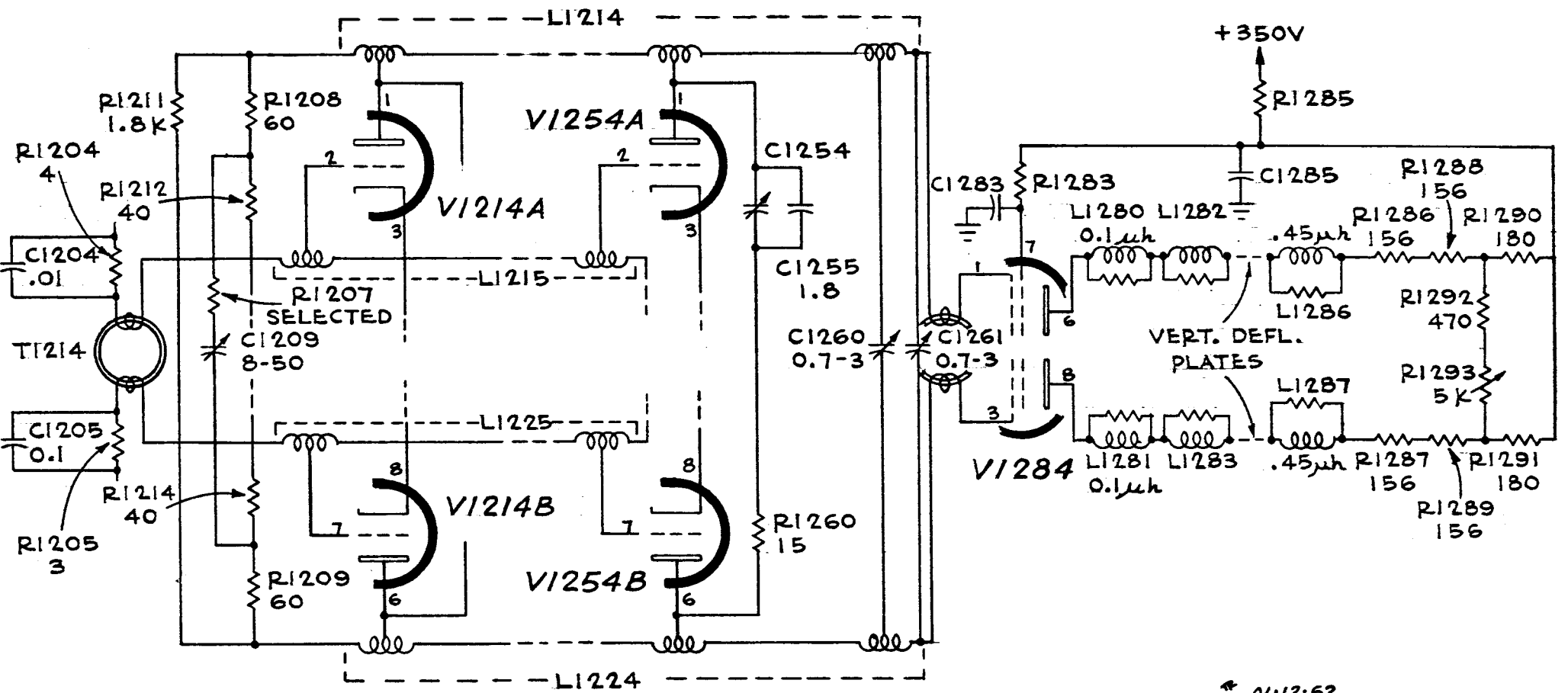

01.12.62

PART. DIAG. VERT. AMP. OUT. STAGE

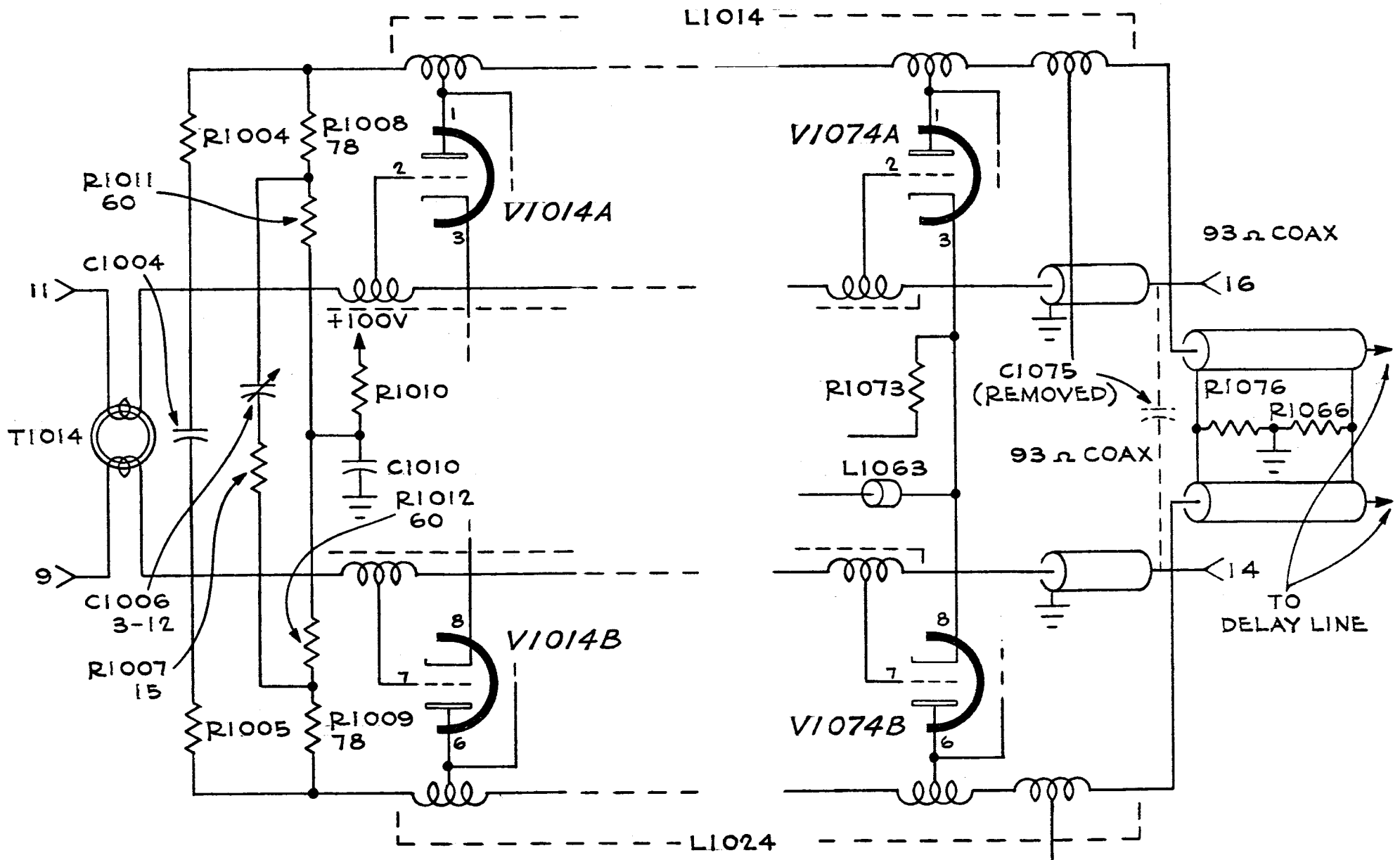

01-12-62

PART. DIAG. VERT. AMP. DELAY LINE DRIVER

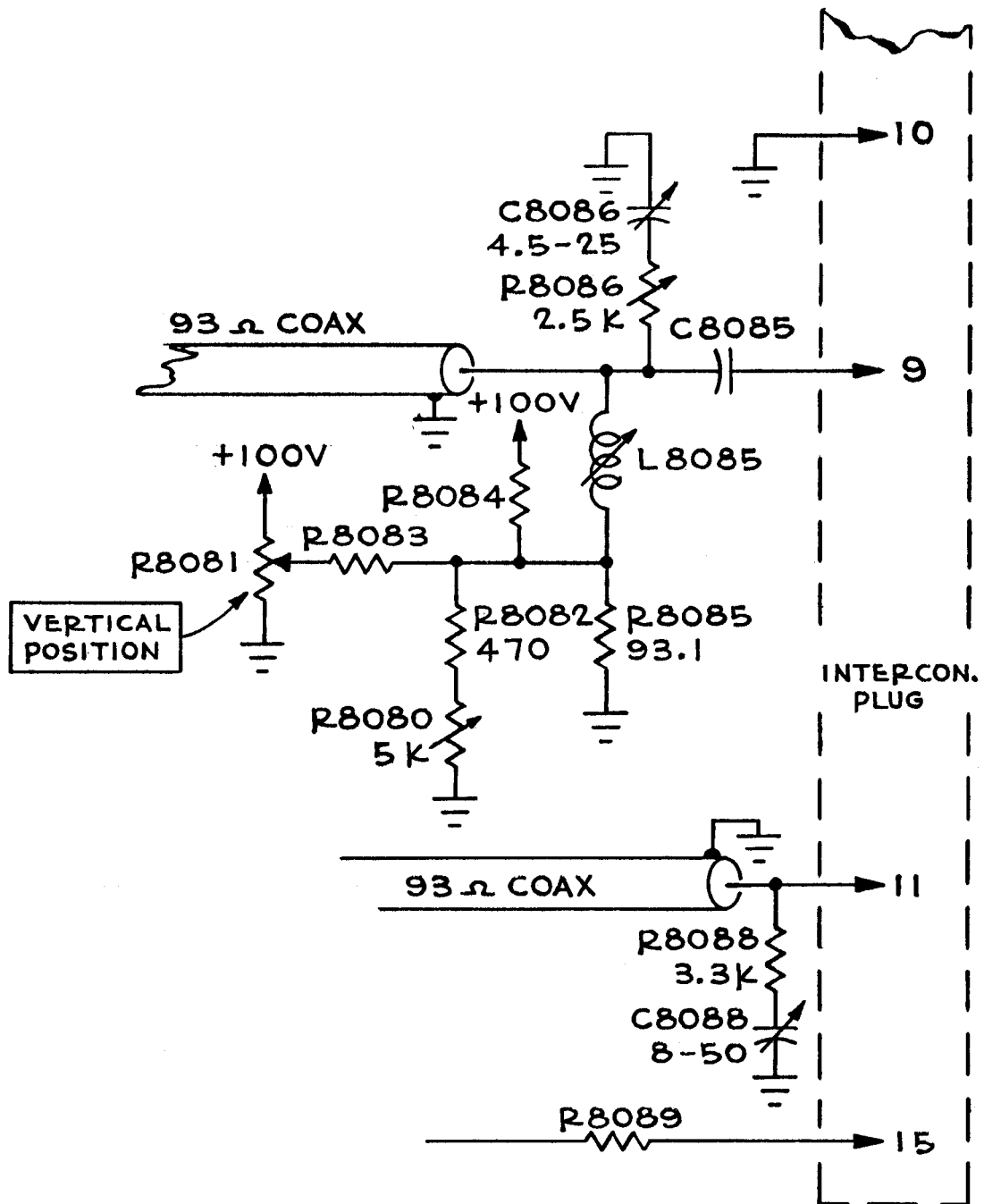

PART. DIAG. 80 PLUG-IN UNIT

01.12.62