

INSTRUCTION MANUAL

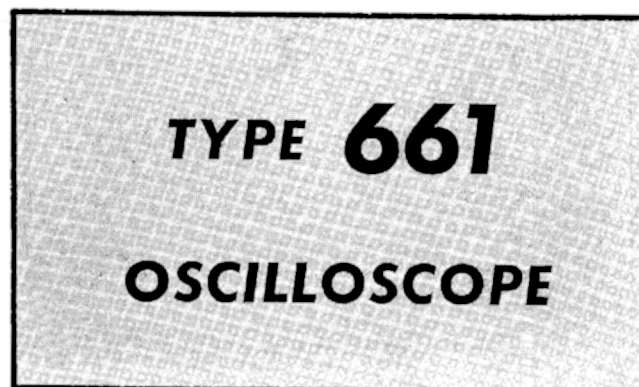

Tektronix, Inc.

S.W. Millikan Way • P. O. Box 500 • Beaverton, Oregon • Phone MI 4-0161 • Cables: Tektronix

Tektronix International A.G.

Terrassenweg 1A • Zug, Switzerland • PH. 042-49192 • Cable: Tekintag, Zug Switzerland • Telex 53.574

070-324

764



WARRANTY

All Tektronix instruments are warranted against defective materials and workmanship for one year. Tektronix transformers, manufactured in our own plant, are warranted for the life of the instrument.

Any questions with respect to the warranty mentioned above should be taken up with your Tektronix Field Engineer.

Tektronix repair and replacement-part service is geared directly to the field, therefore all requests for repairs and replacement parts should be directed to the Tektronix Field Office or Representative in your area. This procedure will assure you the fastest possible service. Please include the instrument Type and Serial number with all requests for parts or service.

Specifications and price change privileges reserved.

Copyright © 1963, new material Copyright 1964 by Tektronix, Inc. Beaverton, Oregon. Printed in the United States of America. All rights reserved. Contents of this publication may not be reproduced in any form without permission of the copyright owner.

CONTENTS

Warranty

- Section 1 Characteristics
- Section 2 Operating Instructions
- Section 3 Circuit Description
- Section 4 Maintenance
- Section 5 Calibration
- Section 6 Parts List and Schematics

A list of abbreviations and symbols used in this manual will be found on page 6-1. Change information, if any, is located at the rear of the manual.

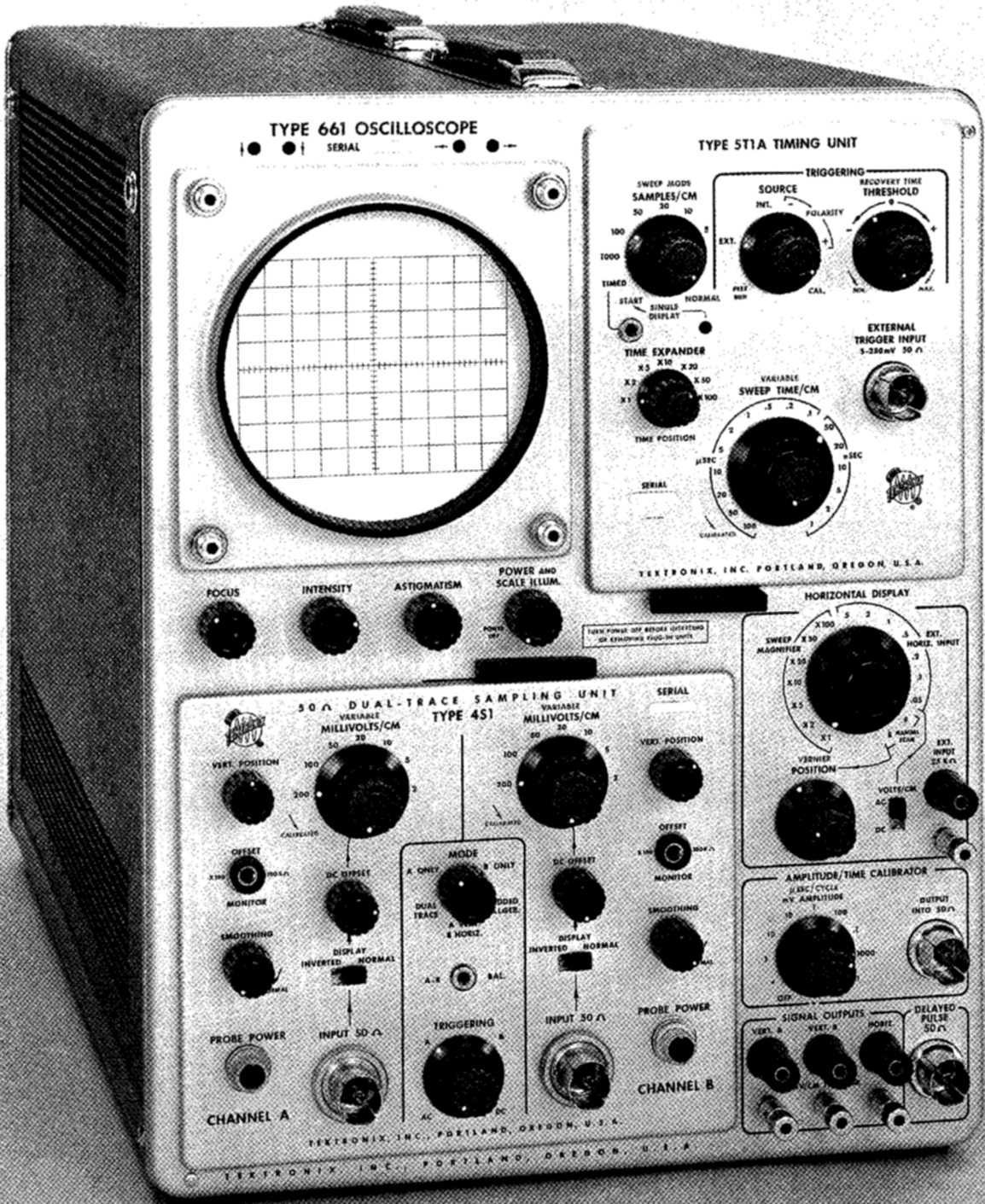

TYPE 661 OSCILLOSCOPE

SERIAL

TYPE 511A TIMING UNIT

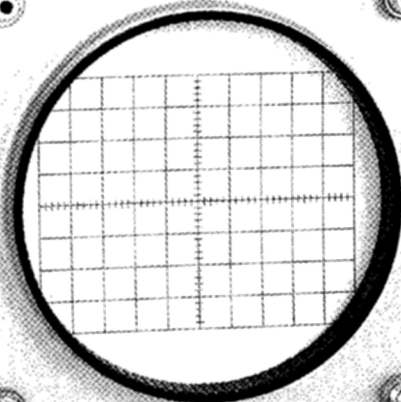

SWEEP MODE SAMPLES/CM: 100, 50, 30, 10, 1000, 10000

TRIGGERING: SOURCE (INT., EXT.), POLARITY (CAL., NORM.), RECOVERY TIME THRESHOLD (MIN., MAX.)

EXTERNAL TRIGGER INPUT: 5-200mV 50 μ S

TIME EXPANDER: X 0.5, X 1, X 2, X 5, X 10, X 20, X 50, X 100

VARIABLE SWEEP TIME/CM: 1, 2, 5, 10, 20, 50, 100 μ SEC

TEKTRONIX, INC. PORTLAND, OREGON, U.S.A.

FOCUS, INTENSITY, ASTIGMATISM, POWER AND SCALE ILLUM., POWER OFF

TURN POWER OFF BEFORE OPERATING OR ADJUSTING HIGH-VOLTAGE PARTS

50 Ω DUAL-TRACE SAMPLING UNIT TYPE 451

VARIABLE MILLIVOLTS/CM: 300, 30, 3, 0.3

VARIABLE MILLIVOLTS/CM: 100, 10, 1, 0.1

CHANNEL A: VERT. POSITION, OFFSET, MONITOR, SMOOTHING, PROBE POWER, INPUT 50 Ω

CHANNEL B: VERT. POSITION, OFFSET, MONITOR, SMOOTHING, PROBE POWER, INPUT 50 Ω

MODE: A ONLY, B ONLY, DUAL TRACES, A & B, A & HORIZ.

TRIGGERING: A, B, AC, DC

TEKTRONIX, INC. PORTLAND, OREGON, U.S.A.

HORIZONTAL DISPLAY

SWEEP MAGNIFIER: X 1, X 2, X 5, X 10, X 20, X 50, X 100

EXT. HORIZ. INPUT: 5, 10, 20, 50, 100 μ S

VERT. POSITION, VOLTAGE/CM, AC, DC

AMPLITUDE/TIME CALIBRATOR

PER. CYCLE % AMPLITUDE: 10, 100, 1000

OUTPUT INTO 50 Ω

SIGNAL OUTPUTS: VERT. A, VERT. B, PULSE, DELAYED PULSE

SECTION 1

CHARACTERISTICS

General Information

The Tektronix Type 661 Oscilloscope is intended for use with two associated plug-in units in a self-contained fractional nanosecond sampling system. An external connector allows use of a digital unit for readout of time and voltage information from the oscilloscope display.

The Type 661 is an indicator unit with power supplies for the vertical and horizontal plug-in units. It contains vertical and horizontal crt deflection-plate drivers, a sweep magnifier, and an external horizontal input. Auxiliary circuits offer front-panel amplitude and time references, output signals from both the vertical and horizontal systems, and a delayed fast-rise pulse occurring soon after the beginning of each sweep. The delayed pulse can be used to check the vertical sampling unit risetime.

Input Characteristics

The vertical system of the Type 661 can be driven by any of the Tektronix '4' Series sampling units. The equivalent bandpass, risetime, vertical deflection factor, and input impedance is a function of the individual plug-in unit in use.

The horizontal system of the Type 661 can be driven by any of the Tektronix '5' Series timing units or by an external input terminal at 25 k input resistance. Individual timing unit sweep rates determine the Type 661 equivalent sweep-time per centimeter.

External Horizontal Input—External horizontal input sensitivities of 0.05 to 5 volts/cm in seven calibrated steps, either ac or dc coupled. Sampling and timing plug-in units must be in place for the external signals to provide horizontal scanning. If the vertical unit is the Type 4S1 Dual-Trace Sampling Unit, external horizontal signals cannot be applied to the horizontal amplifier when the MODE switch is at A VERT. B HORIZ.

Front-Panel Characteristics

Sweep Magnifier—X1, X2, X5, X10, X20, X50, and X100 magnification, symmetrical about the crt center. When using the magnifier, the time per sampling dot remains the same as at X1.

Horizontal Position—Coarse and fine POSITION controls shift the display one crt diameter about its center (unmagnified), and the total trace can be shifted into view on all ranges of sweep magnification.

Manual Scan—Two positions of the HORIZONTAL DISPLAY switch permit the sampling display to be horizontally scanned by rotation of the POSITION controls. Choice of slow or fast rates of change. The slow rate of change may be required when the output waveforms drive a pen recorder.

Amplitude/Time Calibrator—A clipped sine-wave signal with the following tolerances:

Amplitude	at 10, 1 and 0.1 μ SEC/CYCLE	at 0.01 μ SEC/CYCLE
1000 mv	$\pm 2\%$	$\pm 8\%$
100 mv	$\pm 4\%$	$\pm 9\%$
10 mv	$\pm 5\%$	$\pm 10\%$
1 mv	$\pm 6\%$	$\pm 11\%$
Time per cycle	$\pm 0.2\%$	$\pm 2\%$

For instruments having serial numbers from 101 through 1999, the Calibrator sine-wave output is not clipped.

Delayed Pulse—A tunnel diode pulse generator that delivers a fast pulse of at least 350 mv offset by about 200 mv dc into 50 ohms. Risetime at the connector, 70 psec or less (for instruments with serial numbers 270 and up). The pulse occurs about 50 nsec after receipt of a trigger from the timing unit. Risetime appears as about 350 psec or less viewed by a Type 4S1 or Type 4S3, and about 115 psec or less viewed by a Type 4S2. For instruments with serial numbers 101 through 269, risetime at the Delayed Pulse connector is 190 psec or less, appearing as about 390 psec with a Type 4S1 or Type 4S3 and about 210 psec with a Type 4S2.

Signal Outputs—VERT. A, VERT. B, and HORIZ. system signals appear at front-panel terminals at 10 k output impedance. Output amplitude of each signal is 200 mv/cm $\pm 3\%$ referred to the crt display.

Cathode-Ray Tube

Type—T5030-2.

Phosphor—P2. Others available on special order.

Blanking—Deflection type, dc coupled.

Accelerating Potential—Approximately 3000 volts.

Useable Viewing Area—8 cm vertical by 10 cm horizontal.

Graticule

Illumination—Red or white variable edge lighting.

Markings—8 vertical and 10 horizontal 1-cm divisions with 2-mm divisions on the centerlines.

Beam Position Indicators

Indicate direction of off-crt spot or trace. All four lamps will be lighted when spot is near the crt center.

Power Supplies

Temperature isolated, electronically regulated for stable operation with varying line voltage, load, or temperature. Supplies all operating voltages, plus some dc heater current for added stability with line voltage change.

Characteristics—Type 661

Ventilation

Forced filtered air. Thermal relay interrupts instrument power in the event of overheating and restores it after the inside temperature has dropped to a safe level.

Power Consumption

Approximately 445 watts with plug-ins installed.

Construction

Mechanical—Aluminum-alloy chassis and cabinet. Photo-etched anodized panel, blue vinyl paint over textured aluminum cabinet.

Dimensions—Height 17½ inches, width 13 inches, depth 22 inches.

Weight—Approximately 49 pounds.

Accessories Included

	Tektronix Part No.
1 — 3-conductor power cord	161-010
1 — 3- to 2-conductor power cord adapter	103-013
1 — Green crt filter	378-514
2 — Instruction Manuals	070-324

SECTION 2

OPERATING INSTRUCTIONS

CAUTION
ALWAYS TURN OFF INSTRUMENT POWER BEFORE
INSTALLING OR REMOVING PLUG-IN UNITS.

General Information

The Type 661 Oscilloscope is a specially designed indicator unit for Tektronix servo-type, slide-back sampling systems. Sophisticated circuitry permits some vertical sampling plug-in units with internal delay lines to contain all the required trigger-pickoff circuitry. Thus, the sampling system can be self-contained without need of external triggering accessories.

Although mechanical tolerances of the plug-in cells and plug-in units have been carefully controlled, you should use reasonable care when inserting or removing plug-in units. Always turn off instrument power when installing or removing plug-in units.

The Type 661 Oscilloscope and associated plug-in units are designed for operator convenience. For many applications, the system can be operated with the same ease as a conventional oscilloscope. The special controls, either required or permitted by the sampling circuitry, are discussed in this section of the manual. Operating procedures for the plug-in units are discussed in their respective manuals. General Applications are included later in this section.

FUNCTION OF CONTROLS

CRT

- | | |
|------------------------|---|
| FOCUS | Used in conjunction with the ASTIGMATISM control to focus the crt display. |
| INTENSITY | Adjusts the brightness of the display. |
| ASTIGMATISM | Used in conjunction with the FOCUS control to obtain a sharply focused display. |
| POWER AND SCALE ILLUM. | Main ac power on-off switch, concentric with graticule scale illumination control to adjust brightness of the graticule markings. |

HORIZONTAL DISPLAY

The HORIZONTAL DISPLAY switch serves three functions throughout its sixteen positions of rotation. Seven switch positions serve as the SWEEP MAGNIFIER. Seven switch positions serve as the EXT. HORIZ. INPUT gain control. Two switch positions allow a horizontal MANUAL SCAN of the display.

- | | |
|-----------------|--|
| SWEEP MAGNIFIER | Expands the crt display horizontally about the graticule centerline. When using the magnifier, the time between samples (dots) remains the same. Thus, the magnifier affects the crt apparent sweep rate, but does not affect digital information at the rear-panel connector. Magnifier is accurate to 1 dot per centimeter at all sweep rates. |
|-----------------|--|

- | | |
|-------------------|---|
| EXT. HORIZ. INPUT | Permits changing the horizontal amplifier gain for external horizontal signals. External signals are applied to the EXT. INPUT 25KΩ connector. The sampling system permits the external horizontal signal to control the rate at which the crt spot moves horizontally. With the HORIZONTAL DISPLAY switch in any EXT. HORIZ. INPUT position, the display can be the same as if internally controlled, but the scanning rate is a function of the rate of change of the external signal. When externally scanning a sampled display, the samples per centimeter are not calibrated as when internally controlled. |
|-------------------|---|

- | | |
|-------------|---|
| MANUAL SCAN | Permits the POSITION controls to command the sampled waveform horizontal spot position. Rotation of the POSITION control will not move the display horizontally, but will move the spot, scanning the sampled display at a rate controlled by the operator. In the F position of MANUAL SCAN, the spot position moves at the same rate as the rotation of the POSITION control. In the S position of MANUAL SCAN, capacitance coupling in the circuit prevents the spot from starting or stopping quickly, thus the spot usually moves more slowly than the rotation of the POSITION control. Scanning slowly with the POSITION control produces a high dot density on the display. The equivalent sweep TIME/CM is the same as when the SWEEP MAGNIFIER is at ×1, and is dependent upon the Timing Unit. |
|-------------|---|

- | | |
|----------------|---|
| VOLTS/CM AC—DC | A two-position slide switch permitting either ac or dc coupling of the external horizontal input signal. Internal ac coupled time constant is about 25 milliseconds, assuming a zero source impedance external generator. |
|----------------|---|

- | | |
|----------------------|---|
| POSITION and VERNIER | The two POSITION controls permit adjustment of the horizontal position of the trace, or the horizontal position of the spot at the time of no trace. The operating voltage from the POSITION controls is combined with the external horizontal input voltage to control the spot position. Thus, an external scanning voltage can be correctly positioned to present the desired display. |
|----------------------|---|

AMPLITUDE/TIME CALIBRATOR

- | | |
|------------|---|
| μSEC/CYCLE | Six-position switch with four active positions that select the frequency-determining components of the AMPLITUDE/TIME CALIBRATOR. |
|------------|---|

Operating Instructions—Type 661

mV AMPLITUDE Four-position switch that selects the proper attenuator for setting the output amplitude of the AMPLITUDE/TIME CALIBRATOR.

FUNCTION OF CONNECTORS AND TERMINALS

EXT. INPUT 25 K Ω Input terminal for external horizontal scanning voltages, with the HORIZONTAL DISPLAY switch in one of the EXT. HORIZ. INPUT positions. The external input resistance is 25,000 ohms. (See Circuit Description, for additional details.)

OUTPUT INTO 50 Ω 50-ohm General Radio Type 874 coaxial connector that is the output terminal of the AMPLITUDE/TIME CALIBRATOR.

SIGNAL OUTPUTS:
200 mV/CM THRU 10 K

VERT. A A real-time replica of the vertical plug-in unit Channel A output signal, directly coupled from within the vertical unit before any position, dual-trace, or chopping signal. Includes any dc offset information. Can be used with the horizontal output to drive a pen recorder in a repetitive, single display, or manual scan mode.

VERT. B A real-time replica of the vertical plug-in Channel B output signal. Function is identical with VERT. A terminal.

HORIZ. A directly coupled real-time staircase signal from the output of the horizontal pre-amplifier. The output voltage goes negative as the spot moves to the right.

DELAYED PULSE 50 Ω A 50-ohm General Radio Type 874 coaxial connector that delivers a fast-rise negative step from a tunnel diode pulse generator. Amplitude is at least 350 mv. Risetime is 70 psec or less. (190 psec or less, S/N 101-269). The pulse repetition rate is controlled by the timing unit in use, and occurs about 50 nsec after the timing unit is triggered or begins a free-run cycle of the trigger circuit. The DELAYED PULSE 50 Ω output may be used to trigger external equipment. Thus, the Type 661 and its timing unit can serve as a rate generator to initiate external signals that are to be viewed by the sampling system.

Readout Connector (Rear Panel) A rear panel jack permits external analog and/or digital readout of sampling displays. The analog information is similar to the signals that appear at the SIGNAL OUTPUTS terminals. A mating Bendix plug can be ordered from your local Tektronix Field Office (Part Number 131-239).

PRELIMINARY INSTRUCTIONS

Cooling

Before operating the Type 661, a suitable location for the instrument must be chosen. The location should provide a stable support, adequate air circulation, and be far enough from walls or other equipment that might block air intake through the filter or the exhaust passages in the cabinet. If the flow of air through the unit is interrupted, overheating may cause a thermal relay to open, shutting down the power until the temperature drops to a safe operating level.

Power Line Voltage Requirements

The Type 661 Oscilloscope can be operated from 110, 117, or 124 volts, or 220, 234, or 248 volts. The only changes necessary to convert from one operating voltage to another are in the wiring of the power transformer primary, the fan motor, and the rating of the fuse. The power transformer used in the Type 661 uses two separate primary windings plus two 6% boost-buck windings. The primary windings

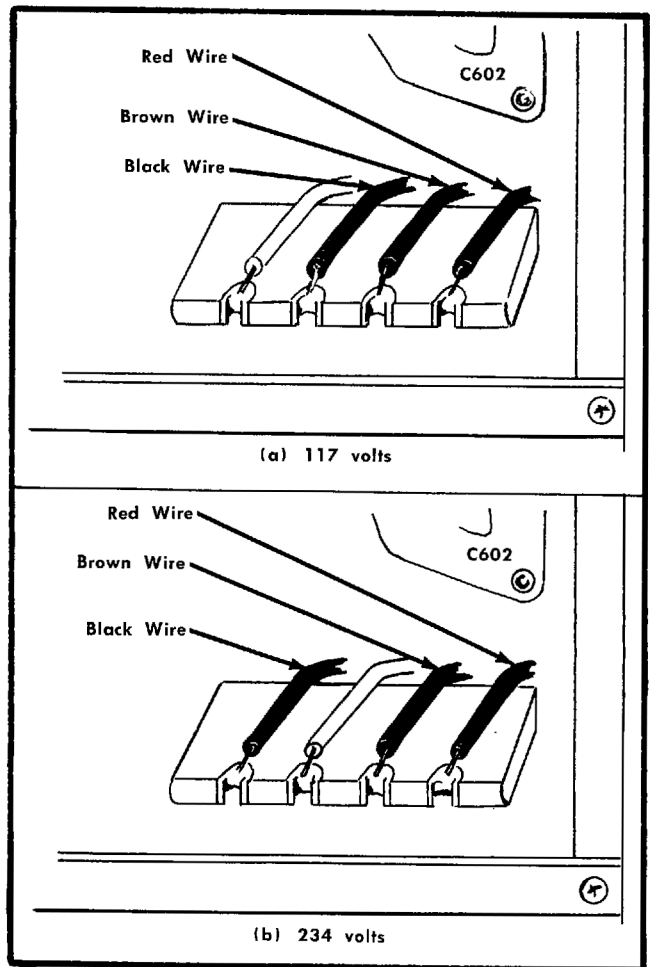

Fig. 2-1. Fan connections for 117- and 234-volt power line operation.

are connected in parallel for 117-volt operation and in series for 234-volt operation. Proper connections for each line voltage are shown on the under side of the power transformer and on the Power Supply schematic.

A small metal tag near the power receptacle at the rear of the instrument indicates the line voltage for which your unit was wired at the factory. If wired for 117 volts, the instrument will operate properly with line voltages between 105 and 125 volts, rms. If wired for 234 volts, the instrument will operate properly from approximately 210 to 250 volts, rms.

To change the power transformer connections for operation on another line voltage, change the location of the bare wire straps at the primary terminals. It is not necessary to move any of the plastic insulated wires. Place the new straps in accordance with the markings on the tag located on the power transformer side.

Correct fan motor wiring is illustrated for both 117-volt and 234-volt operation in Fig. 2-1. The ceramic strip shown in Fig. 2-1 is located on the right side near C602.

Fuse Data

Fuse data for proper power transformer protection is indicated on the rear panel adjacent to the fuse holder. Always use the correct fuse.

Time Delay

A time-delay relay in the Type 661 delays operation of the power supply dc voltages for about 30 seconds after the power switch is turned on. The delay allows a brief tube-warmup period before the dc operating voltages are applied. After the relay closes, some of the plug-in heater circuits require an additional warmup time before the total sampling system is ready for operation.

If the ac power is interrupted for longer than about one quarter of a second, the normal 30-second delay will recur before the power supplies will be turned on again.

Graticule

The graticule is illuminated by two incandescent lamps located at the top edge of the graticule. The POWER AND SCALE ILLUM. control reduces the brightness of the graticule markings when rotated clockwise. The graticule can be inverted, permitting a choice of either red or white graticule coloring. White graticule lines are usually best for photographing crt displays.

FIRST TIME OPERATION

General

When a suitable operating location has been chosen, set the POWER AND SCALE ILLUM. control to the POWER OFF position and connect the instrument to an appropriate source of power.

Be sure to observe the "power off" caution on the Type 661 front panel before inserting a plug-in unit. Otherwise, you will subject the plug-in units to possible semiconductor damage.

With the power OFF, place the desired '4' Series sampling unit in the larger cell under the crt, and the desired '5' Series timing unit in the upper cell to the right of the crt. Begin plug-in insertion by placing the gray locking latch perpendicular to the oscilloscope front panel, then push the plug-in unit into the cell as far as possible by hand. Move the locking latch flush with the panel to lock the plug-in unit in place.

To remove a plug-in unit, first turn the power off, then move the gray locking latch perpendicular to the front panel, and withdraw the unit by hand.

Checking Plug-In Unit Accuracy

The Type 661 Oscilloscope contains an AMPLITUDE/TIME CALIBRATOR to permit quick checks on the vertical sensitivity and horizontal timing accuracies. See the Characteristics section of this manual for the AMPLITUDE/TIME CALIBRATOR accuracies.

NOTE

On the assumption that the sampling system in use consists of the Type 661 Oscilloscope, a Type 4S1 Dual-Trace Sampling Unit, and a Type 5T1A Timing Unit, the following paragraphs on first time operation will be of value. (If other plug-in units are involved, see the individual unit instruction manual for first time operation information.)

The Type 661 Oscilloscope, and its plug-ins have been independently factory calibrated before shipment. The Type 661 vertical and horizontal amplifier deflection factors have been correctly calibrated and are not to be adjusted except by following the calibration procedure in this manual. The system, as received, should be assembled and checked for proper gain and timing before relying upon the overall sampling system for critical amplitude or time measurements.

Front-panel control settings should be:

	Type 4S1
MODE	A ONLY
'A' POSITION	Midrange
'A' SMOOTHING	Clockwise
'A' MILLIVOLTS/CM	200
'A' VARIABLE	CALIBRATED (at detent)
'A' DISPLAY	NORMAL
TRIGGERING	A - AC
DC OFFSET	Set to zero with volt-meter connected to OFF-SET MONITOR jack.

Other controls may be in any position.

Operating Instructions—Type 661

Type 5T1A	
SWEEP TIME/CM	10 nSEC
VARIABLE	CALIBRATED (at detent)
SWEEP MODE	NORMAL (REPETITIVE)
TRIGGERING SOURCE	INT.
POLARITY	—
TIME POSITION (DELAY)	Clockwise (minimum)
TIME EXPANDER	×1
THRESHOLD	Pointing near +
SAMPLES/CM	100
RECOVERY TIME	MIN.

Type 661	
HORIZONTAL DISPLAY	×1
FOCUS	Midrange
INTENSITY	About 3 o'clock
ASTIGMATISM	Midrange
AMPLITUDE/TIME CALIBRATOR	See step 2, following

It may be necessary to change the setting of the crt controls for proper focus and intensity.

NOTE

The alignment of the crt trace is a function of the earth's magnetic field. The alignment will change if the location of the instrument is changed, and will even vary slightly with a 90-degree change in position of the instrument. To align the trace, remove the left side panel and locate the red crt rotation knob (part of the crt mounting clamp). Rotate the crt until the trace aligns with a horizontal graticule marking. This adjustment should be made when the instrument is in its most probable operating location and position.

The Type 5T1A control settings will produce a free-running trace. To obtain a stable display of a vertical signal, rotate the THRESHOLD control. Since the Type 5T1A Instruction Manual contains a detailed description of proper triggering techniques, only a simple discussion is included here.

With the Type 5T1A POLARITY switch at —, turning the THRESHOLD control fully counterclockwise holds off the triggering system for normal amplitude negative trigger signals. If the trigger signals are too great in amplitude and the THRESHOLD control cannot stop the display, false timing may result. Turning the THRESHOLD control in the clockwise direction permits proper triggering as the trigger-to-threshold voltage difference is brought to zero. Triggering first occurs as the most negative portion of the triggering information reaches the threshold voltage. Turning the THRESHOLD control further clockwise finally produces a free-running sweep. The free-running sweep occurs either as the triggering signal internal voltage base line is reached by the threshold voltage, or as the threshold voltage passes through zero. Thus, the front-panel conditions called out for the Type 5T1A place the triggering voltage in the positive

region, and the triggering circuitry will cause the generation of a free-running trace. The same conditions exist when the POLARITY switch is at + and the THRESHOLD control is turned in the opposite direction.

1. Check the DELAYED PULSE Generator Operation

Connect a short length of 50-ohm cable between the Type 661 DELAYED PULSE generator and the Type 4S1 Channel A input connector. Do not use an attenuator.

The display should now be a negative-going step of about two centimeters vertical amplitude, 40 to 60 nanoseconds after the start of the sweep. It may be necessary to adjust the TIME POSITION (DELAY) or the vertical and horizontal POSITION controls to center the display. If there is no step signal, remove the Type 661 right side panel and locate the DELAYED PULSE GEN. BIAS potentiometer (R990) at the lower side near the front panel. Adjust it for a crt display as described previously (see Fig. 2-2).

Slowly withdraw the cable connector until the center conductor is barely disconnected. The display should show approximately one-half to one centimeter of capacitively-coupled signal. If no signal appears or if the display is not stable, the Delayed Pulse generator is free running. Readjust R990 until both the Delayed Pulse display and the capacitively-coupled display remain stable as the cable is alternately connected and disconnected.

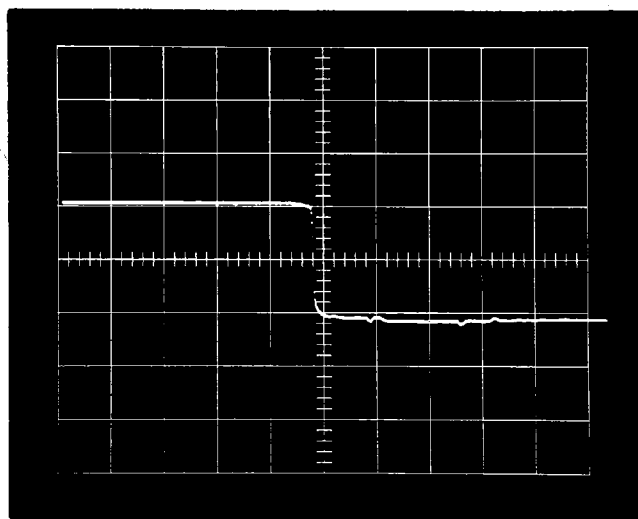

Fig. 2-2. DELAYED PULSE waveform. TIME/CM, 10 nSEC

2. Check the Type 4S1 Channel A Gain

Disconnect the cable from the DELAYED PULSE generator and connect it to the AMPLITUDE/TIME CALIBRATOR. Set the AMPLITUDE/TIME CALIBRATOR controls to .1 μSEC/CYCLE and 1000 mV AMPLITUDE. Set the Type 5T1A SWEEP TIME/CM switch to .1 μSEC.

The front-panel screwdriver adjust control labeled A-B BAL. is the Channel A gain control. The panel is labeled A-B BAL. to indicate the control permits a small adjustment

of the Channel A gain when operating the Type 4S1 in the Added Algebraic mode. The control does not affect the Channel B gain.

Trigger the Type 5T1A with the THRESHOLD CONTROL. The display should now be a 10-mc calibrated waveform, with a peak-to-peak vertical amplitude of 5 centimeters ($\pm 3\%$). Adjust the A-B BAL. control if the display is other than 5 centimeters.

NOTE

The appearance and amplitude of the calibrator signal may seem to change slightly with frequency and with the type of vertical plug-in unit used. In general, these changes are due to normal characteristics of the input cable and the vertical plug-in unit. It is important to keep these characteristics in mind when viewing any input signal in order to correctly interpret the display. Fig. 2-3 shows typical displays of the calibrator waveform with the calibrator circuit and the plug-in units all correctly calibrated.

3. Check the Type 4S1 Channel B Gain

Set the Channel B controls identical to the Channel A controls, the Type 4S1 MODE switch to B ONLY, and the TRIGGERING controls to B and AC. Measure and adjust the OFFSET MONITOR to zero volts. Move the 50-ohm cable to the Channel B input connector.

If the vertical display is not within 3% of 5 centimeters, remove the left side panel and adjust the internal B CAL. control. The B CAL. control is located at the top rear of the Type 4S1 plug-in unit. Reach in from the top with a long insulated screwdriver, and adjust B CAL. for exactly a 5-centimeter vertical display.

4. Check the Type 5T1A Basic Timing

Leave the Type 5T1A SWEEP TIME/CM at .1 μ SEC and the Type 661 AMPLITUDE/TIME CALIBRATOR at .1 μ SEC/CYCLE and 1000 mV AMPLITUDE.

The crt display should now be a 10-megacycle calibrator waveform with one cycle each horizontal centimeter. Tolerance with this test method is $\pm 3\%$. If the timing is inaccurate, locate the SWEEP CAL. control in the middle of the right side of the Type 5T1A, and adjust for proper crt display timing.

Check the sweep timing through the range of the Type 5T1A SWEEP TIME/CM switch as indicated in Table 2-1.

TABLE 2-1

SWEEP TIME/CM	AMPLITUDE/TIME CALIBRATOR	Display
.1 μ SEC	.1 μ SEC/CYCLE	1 cycle/cm
2 nSEC	.01 μ SEC/CYCLE	1 cycle/5 cm
10 nSEC	.01 μ SEC/CYCLE	1 cycle/cm
1 μ SEC	1 μ SEC/CYCLE	1 cycle/cm
10 μ SEC	10 μ SEC/CYCLE	1 cycle/cm

Adjust the Type 5T1A SWEEP CAL. control so that all display possibilities of Table 2-1 are within 3% of the indicated values.

5. Check the Samples per Centimeter

Remove the signal cable from the Type 4S1 input. Set the Type 5T1A SOURCE switch to FREE RUN, the SWEEP TIME/CM switch to 1 μ SEC, and the SAMPLES/CM switch to 5.

The display should now be five dots per centimeter (one dot every two millimeters). If the display is not precisely one dot every two millimeters, adjust the SAMPLES/CM CAL control, R304. R304 is located on the inside of the Type 5T1A adjacent to V361. Adjust it until there is a dot located right behind each minor and major graticule marking.

With the checks just completed, the Type 661, Type 4S1, and Type 5T1A are calibrated as a unit within 3% vertically and horizontally. Replace the Type 661 side panels.

Both the vertical and horizontal systems can be made more accurate with external voltage and time references. For example, using the DC OFFSET with an accurate high impedance meter, vertical signals can be measured within 1%. Thus, the above system of gain calibration is not the ultimate. For the greatest accuracy, use the calibration procedure for the appropriate plug-in unit.

Operating the AMPLITUDE/TIME CALIBRATOR

The AMPLITUDE/TIME CALIBRATOR is a self-excited oscillator with both an external and internal signal output. The internal signal is coaxially coupled to the timing unit plug-in cell to provide internal triggering of the sampling display. The internal signal amplitude is independent of the front-panel mV AMPLITUDE control permitting stable triggering even in the 1-mv position. Turn the calibrator off when not being used to avoid display-time jitter.

The AMPLITUDE/TIME CALIBRATOR will operate independently of the sampling system and therefore can be employed as a signal generator for other applications. However, the calibrator accuracy listed in the Characteristics Section of this manual applies only when the calibrator load is 50 ohms.

Operating the DELAYED PULSE Generator

The DELAYED PULSE generator is a tunnel-diode step generator operated by the timing unit each time a signal is sampled. Free run the timing unit to use the DELAYED PULSE generator to trigger an external system. Because the free run repetition rate of the timing unit trigger circuit controls the rate generator function, see the individual timing unit instruction manual for the DELAYED PULSE repetition rates at various sweep rates.

GENERAL APPLICATIONS

General applications for the Type 661 indicator can be accomplished with any present or future '4' Series vertical

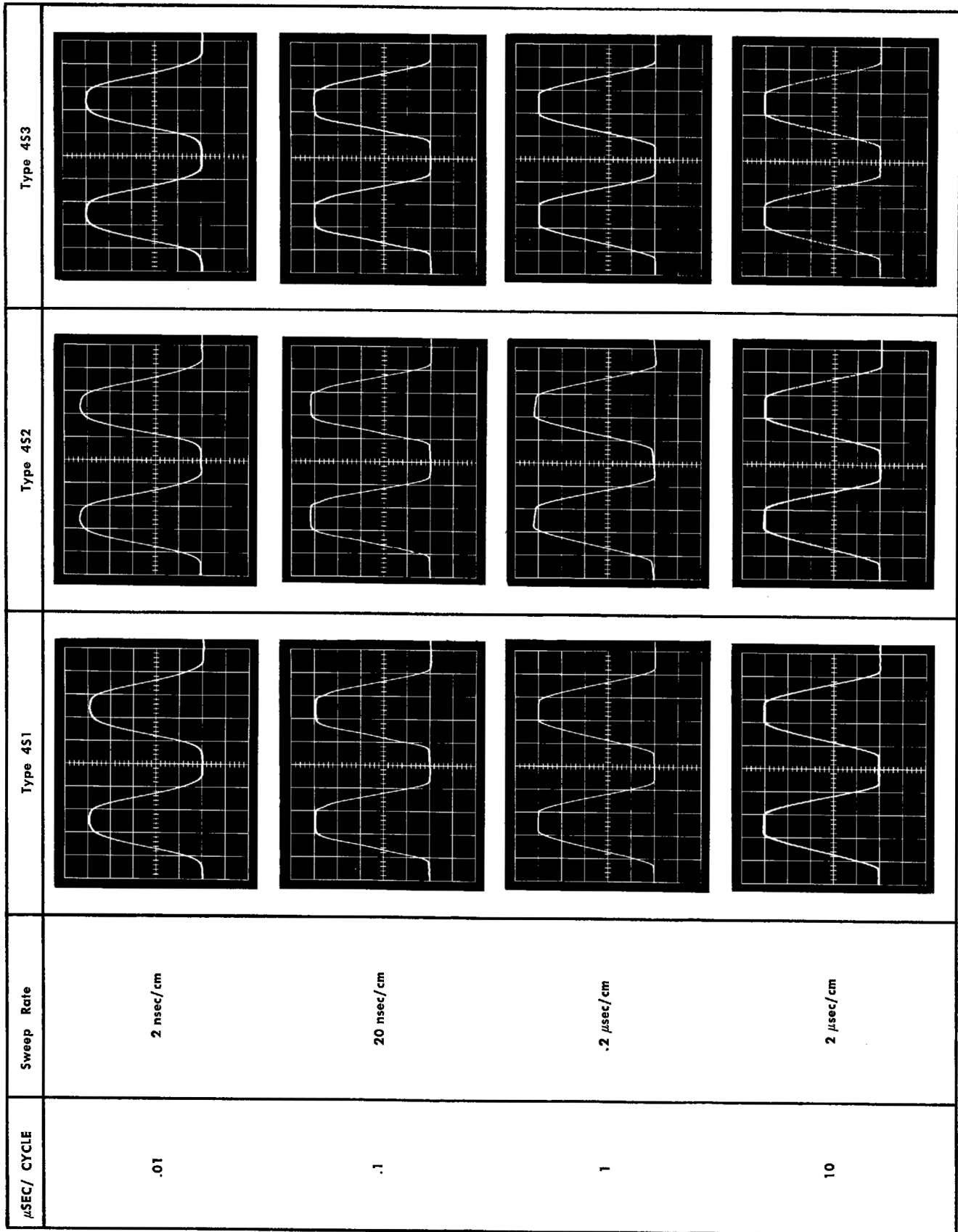

Fig. 2-3. Typical 1000 mv Amplitude/Time Calibrator displays as viewed with various vertical plug-in units. (This illustration applies only to Type 661 Oscilloscopes with serial numbers 2000 and above.) The waveshape and amplitude are factory-adjusted with a Type 453 Sampling Unit, P6038 Probe and VP-2 Voltage Pickoff.

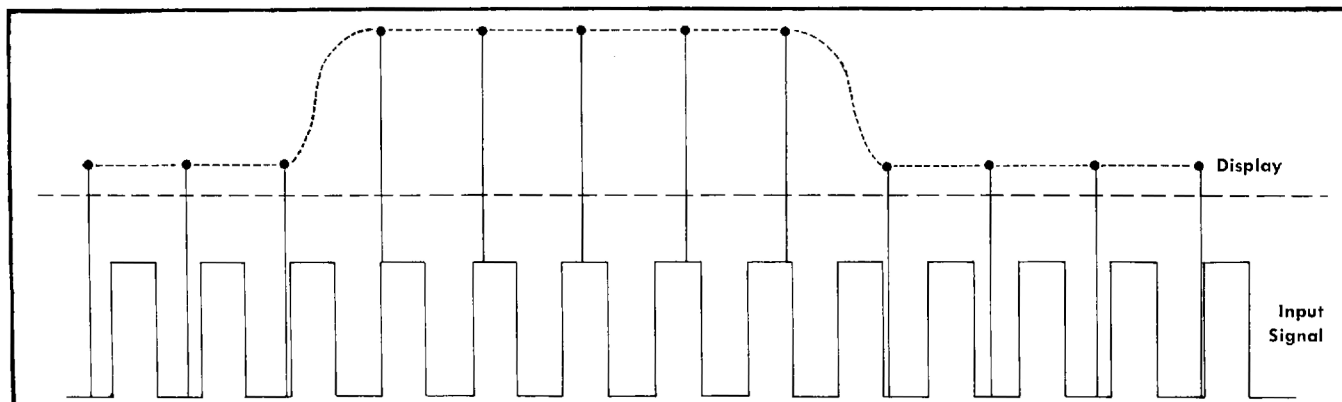

Fig. 2-4. Displaying an input signal by means of the sampling technique. The level of the display is altered only when the display level changes between samples. After the display level has been corrected, the crt is turned on to show the new waveform level. A large number of sampling dots make up the crt display.

or '5' Series horizontal plug-in units. Applications for particular plug-in units are discussed in the individual plug-in unit instruction manuals.

External Control of the Sampling Display

As mentioned in the discussion of control functions, the EXT. INPUT 25 K Ω connector can receive external scanning signals. The normal sampling system operates on repetitive signals, viewing the signal repeatedly but at a slightly later time for each sample. Thus, the crt display is a reconstructed waveform made up of bits of the original repetitive signal. Fig. 2-4 illustrates the normal sampling concepts.

It is essential to a sampling system for the input signal to be repetitive. If the signal is a series of pulses, they may occur at random intervals (as in the use of an ordinary oscilloscope). A sampling display is a long-time reconstruction of a real-time signal, with a large real-time difference expressed as an equivalent time. The rate at which the equivalent-time display reconstructs the real-time waveform is controlled by (a) the signal repetition rate (if the repetition rate is below 100 kc in the Type 5T1A—if above 100 kc, the 5T1A counts down), and (b) the number of samples per centimeter. The number of samples per centimeter can be controlled by the timing unit, the horizontal POSITION control for manual scan, or by an external horizontal voltage. Thus, the length of time required to reconstruct the equivalent time display does not necessarily bear a relationship to the real-time signal.

After obtaining a sampling display, setting the HORIZONTAL DISPLAY switch to any of its EXT. HORIZ. INPUT positions permits the display to be scanned at a rate different from the timing unit.

As an example, the following steps will help you understand an externally scanned sampling display:

1. Coax couple the DELAYED PULSE to the vertical sampling unit.
2. Free-run the timing unit at 2 nSEC/CM.
3. Set the SWEEP MAGNIFIER at X1 and position the start of the trace at the left edge of the graticule. With

the timing unit TIME POSITION (DELAY) control, position the delayed pulse step to the center of the graticule.

4. Set the HORIZONTAL DISPLAY switch to the 2 EXT. HORIZ. INPUT position. The trace should disappear. The spot will be off the left edge of the graticule as indicated by the horizontal position indicator lamps.

5. Slowly turn the horizontal POSITION control fully clockwise. The spot will move to the right across the crt, display the step at the center of the graticule where the original display step occurred, and stop before it reaches the right side of the graticule. The motion of the horizontal POSITION control is identical to introducing a positive-going external signal of about 15 volts.

6. Remove the left side panel and use a patch cord to couple approximately 6.3 volts ac from a graticule scale illumination lamp to the EXT. INPUT 25 K Ω connector.

7. Set the scale illumination at maximum brilliance. Increase the horizontal sensitivity to .5 volts/cm by setting the HORIZONTAL DISPLAY switch to .5 (EXT. HORIZ. INPUT). The display should now appear similar to the original internally controlled display, but it is now swept back and forth at a 60-cycle rate.

The significant difference between an internally scanned display and the POSITION control scanned display is that the timing unit normally displays each sample as it is taken. For external scanning operation with a dc input, the timing unit continues to sample the incoming signal in a normal manner, but the crt is permitted to show only one spot, representing one time point of the display. You can imagine that the display is held in the background, and slowly scanned to show where it should be. The vertical and horizontal signal output voltages (SIGNAL OUTPUTS) follow the visible display whether it is internally or externally scanned. In the external scan mode, the signal output voltages follow the display as it is scanned either by the POSITION control or by the external horizontal signal.

Analog X-Y Recording of Nanosecond Displays

External operation of the Type 661 sampling display can be valuable for paper recording of nanosecond waveforms by low-frequency X-Y plotters.

Operating Instructions—Type 661

Connecting an X-Y plotter to the proper SIGNAL OUTPUTS terminals can produce a permanent paper record of nanosecond displays. Since most plotters function best on slow waveforms, the display scanning must be slowed down by using either the MANUAL SCAN control or an external scanning voltage. For very complex waveforms where the rate at which the display reconstruction must be externally controlled, the X-Y plotter horizontal system can be used to drive the Type 661 external input at its own most satisfactory rate.

If the Type 661 drives both the vertical and horizontal axis of the plotter, it may be necessary to invert the HORIZ. output signal. The HORIZ. output signal goes negative as the spot moves to the right. The VERT. output signals may not need inversion since the vertical voltage goes positive as the spot moves up.

Digital Readout of Nanosecond CRT Displays

The 41-pin Bendix jack on the rear panel of the Type 661 permits digital readout of sampling displays. The schematics show which circuits are included. The rear-panel jack also contains information of an analog nature, similar to the information that appears at the front-panel SIGNAL OUTPUTS terminals. A mating Bendix plug can be ordered from your local Tektronix Field Office (Part Number 131-239).

Viewing Pulses of Statistically Varying Amplitude

The Type 661 and its associated sampling units permits observation of nanosecond pulses of widely varying amplitude, such as those from radiation detectors. Special circuitry must be employed to permit a non-jumbled display*. The sampling system adjusts the vertical position of the crt spot with each sample. If the samples are obtained from pulses of statistically varying amplitude, the normal sampling display will be a jumble of dots with little meaning.

To view (1) pulses with arbitrary interpulse periods of more than 10 microseconds, or regular periods less than 10 microseconds, and (2) if the pulse shape for a given amplitude is essentially consistent, you may use a single-channel analyzer to select the pulses of a given amplitude for display. Apply the output of the single-channel analyzer through proper circuitry to the Type 661 crt blanking circuit.

To view statistically varying amplitude pulses, the vertical plug-in unit SMOOTHING control must be set to NORMAL for proper dot transient response. Under normal internally triggered conditions, the Type 661 sampling system looks at each pulse in a fashion illustrated in Fig. 2-5. Thus, the crt must be blanked except during the time the sampling system looks at consistent amplitude pulses. See Fig. 2-6. The Type 661 crt spot is normally on. Thus, external circuitry for this application must turn off the crt spot except when a correct amplitude pulse has been sampled. Assuming the single-channel analyzer output rests at a negative

*Robert Sugarman: "Sampling Oscilloscope for Statistically Varying Pulses", Review of Scientific Instruments, Nov, 1957, Vol. 28, No. 11.

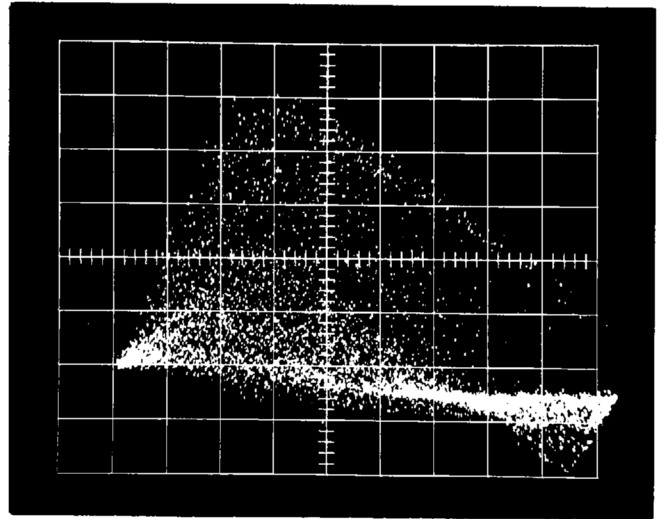

Fig. 2-5. Type 661 presentation of pulses from a Scintillation Counter. Counter used on Na I crystal and an RCA 5819 Photomultiplier. Time scale is 0.1 $\mu\text{sec}/\text{cm}$. Display would be similar for 1-nsec wide pulses and correct time base.

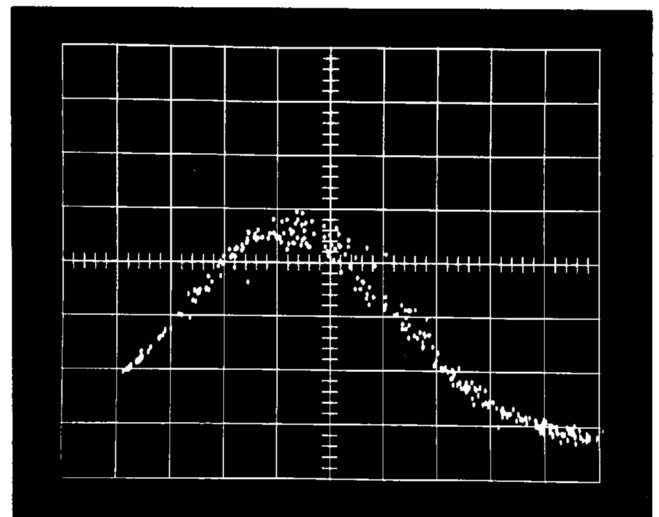

Fig. 2-6. Type 661 presentation of pulses previously shown in Fig. 2-5, but with a single-channel analyzer gating the crt beam.

value and rises to ground when a pulse enters its 'window', the system of Fig. 2-7 will allow proper crt spot control. The single-channel analyzer crt control pulse must remain at ground level at least 10 microseconds for adequate light output of the crt display.

In the event your single-channel analyzer input gate circuit is regenerative and pushes a pulse back into its input cable with each input pulse, proper isolation must be provided for the Type 661 signal. Note in Fig. 2-7 that the output of the single channel is applied through a transistor to terminals G and H (not g and h) of the Type 661 rear-panel Readout connector. The crt remains blanked except when the proper amplitude pulse is seen by the single-channel analyzer.

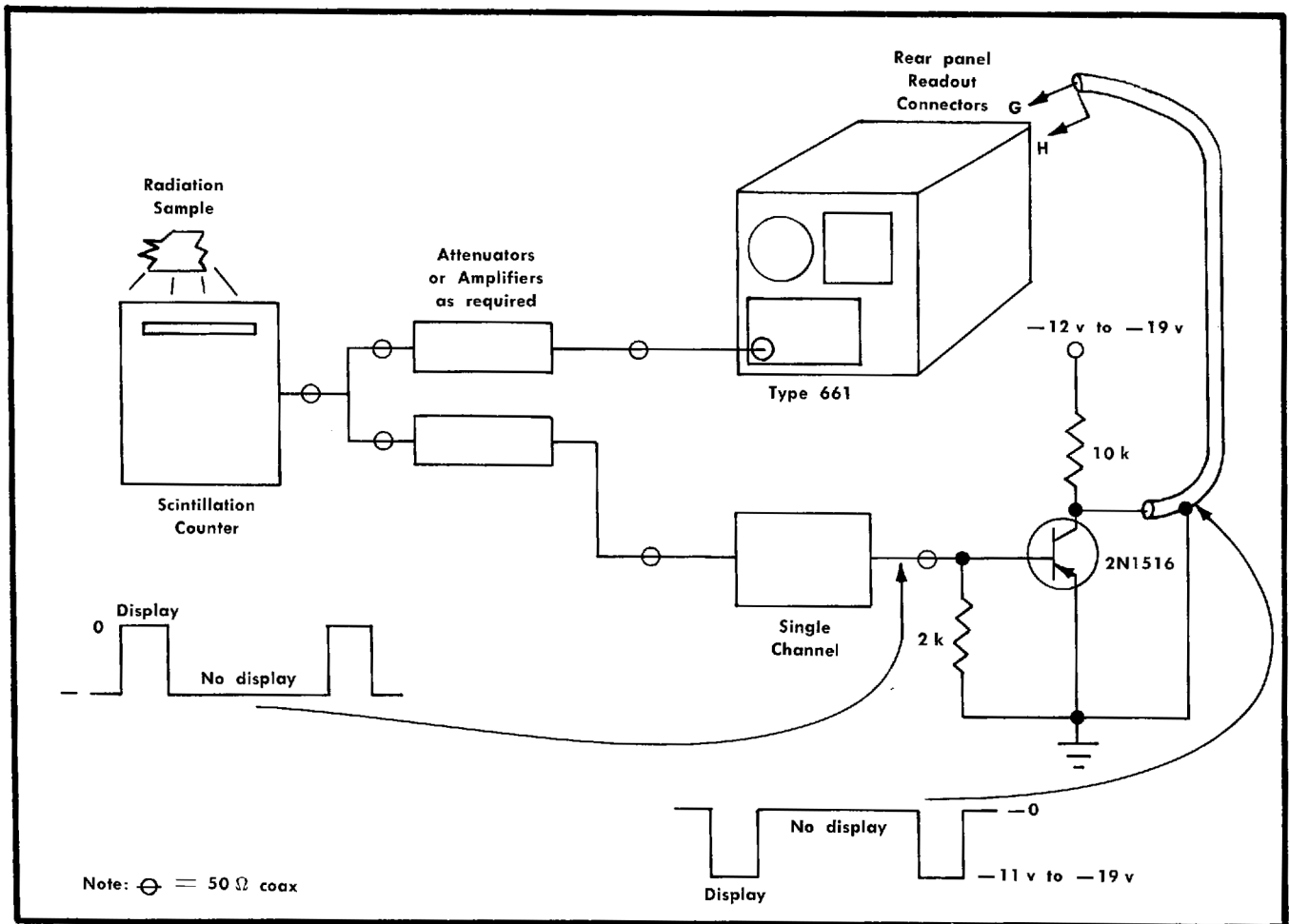

Fig. 2-7. Scintillation counter, single-channel analyzer, crt unblanking circuit and Type 661. System permits viewing pulses of statistically varying amplitude, as shown in Fig. 2-6.

For random occurrence pulses, the final display may be rather erratic. A time exposure photograph of the crt display will usually permit waveform analysis. For pulses that occur at about a 10-kc rate, the gated display should be virtually continuous.

In the event a single-channel analyzer is not available, an alternate system shown in Fig. 2-8 can be used. (This system was used to take the photograph in Fig. 2-6.) In place of the single-channel analyzer, two Tektronix Type 110 trigger regenerator systems and a specially constructed anti-coincidence and crt gating circuit can be employed. The Type 110 trigger regenerators are single-transistor blocking oscillators with an output of about ten volts, either positive or negative. (See the Type 110 instruction manual.) Both trigger regenerators are fed a scintillation counter output signal. A 1000 to 1 isolation between the two Type 110 regenerator input terminals is necessary to prevent interaction of the blocking oscillators. The Type 110 regenerator blocking oscillators kick a signal back into the input cable each time they fire.

The output signals of the Type 110 trigger regenerators are set for opposite polarities. The positive regenerator is made to be more sensitive than the negative regenerator,

and the two equal amplitude, opposite polarity output pulses are then fed to an anti-coincidence circuit. The anti-coincidence circuit permits an output pulse to be applied to a crt gating multivibrator when the amplitude of the scintillation counter pulses are within a certain 'window' value. If only the positive output Type 110 delivers a pulse, the anti-coincidence circuit passes on the pulse to the crt gating multi. However, if the negative output Type 110 delivers a pulse at the same time the positive pulse is generated, the anti-coincidence circuit does not send a gating pulse. Thus, a single-channel 'window' is effectively established.

It is important to use something like the anti-coincidence circuit to keep the two output pulses from the Type 110 trigger regenerators from interacting. The Type 110 blocking oscillators will fire with very small signals arriving through their output cables. Thus, their outputs must be effectively isolated.

The anti-coincidence circuit drives a crt gating multivibrator and inverter that generates a 15-microsecond pulse to turn on the crt beam. Thus, even though the Type 661 system looks at all scintillation counter output pulses, the single-channel analyzer turns on the crt beam only if the system looked at a pulse of the correct amplitude.

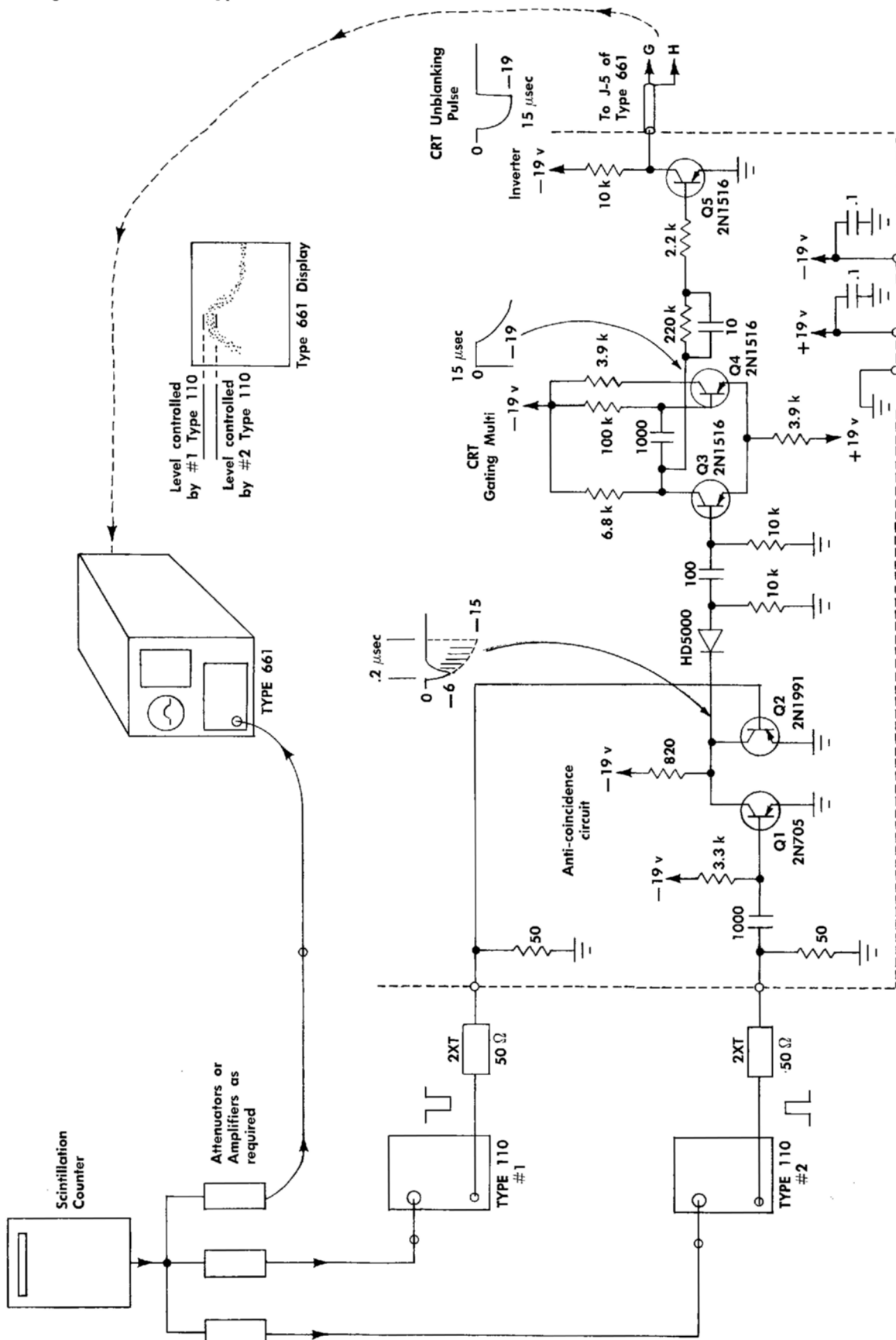

Fig. 2-8. Single-Channel Analyzer (dotted line) and associated system.

Note: ⊕ = 50 Ω coax

Operation of the anti-coincidence circuit of Fig. 2-8 is as follows: Q1, a fast collector-cleanout PNP transistor, is normally forward biased into heavy conduction and its collector is saturated. A slower collector-cleanout PNP transistor, Q2, is normally not conducting. Reverse bias pulses applied to the base of Q1 will turn it off quickly, sending a negative trigger to the crt gating multi. If at the same time that Q1 is turned off, Q2 receives a forward bias signal at its base, the common collectors of Q1 and Q2 cannot generate a negative gating trigger. Thus, if two signals occur in coincidence at the bases of Q1 and Q2, there will not be an output pulse. Q2 was chosen to have a longer collector-cleanout time after being turned off to assure that the common collector lead cannot start negative at the end of the two pulses from the Type 110 trigger regenerator systems.

Operation of the crt gating multi is straightforward, and the waveforms included with the diagram explain its operation. The system, as described, should work satisfactorily

with scintillation counter pulses of about 50 millivolts amplitude and 1 nanosecond wide.

Power for the operation of the anti-coincidence circuit, and the crt gating multivibrator and inverter, can be obtained from the +19- and -19-volt power supplies within the Type 661 indicator. All signal cables and connectors must have good pulse fidelity. The crt gating leads can either be connected through a mating Bendix connector, or they can be inserted directly into the rear-panel connector using two number eighteen wires on the end of a 50-ohm cable.

An alternate, highly sophisticated method for viewing statistically varying pulses in a 'window', would employ a high-speed decision. This requires a fast single-channel analyzer that can decide whether each pulse is within the 'window'. The high-speed analyzer output could externally trigger the timing unit. With such a system, the dots will occur in proper order, the sampling unit SMOOTHING control will function correctly, and readout will be practical. Additional delay in the signal path may be required.

SECTION 3

CIRCUIT DESCRIPTION

General Information

The Type 661 Oscilloscope consists of five major parts: the low-voltage Power Supply, the CRT Circuits, the Horizontal Amplifier, the Vertical Amplifier, and the Amplitude/Time Calibrator. Auxiliary circuits are a 50-ohm Delayed Pulse Generator, and the Signal Output terminals.

The low-voltage Power Supply provides regulated outputs of -100 , -25.2 , -19 , $+19$, $+100$, and $+300$ volts dc. -12.6 volts, obtained from the -25.2 -volt supply, is used for heater current in cathode-follower probes. The $+455$ -volt unregulated voltage is used by the crt high-voltage supply, and is available to the sampling and timing cells for possible plug-in use.

The Horizontal Amplifier and the Vertical Amplifier receive information from the appropriate plug-in unit. They are current-sensitive operational amplifiers, used to drive the crt deflection plates.

The CRT Circuits contain the high-voltage regulated power supply, the crt, and a blanking mixer. The high-voltage supply provides a nominal 3000-volt accelerating potential for the crt.

The Amplitude/Time calibrator is a self-excited, self-regulating, Colpitts oscillator controlled by the $\mu\text{SEC}/\text{CYCLE}$ and mV AMPLITUDE switches.

The Delayed Pulse generator (Interconnecting Sockets schematic) is an internally triggered tunnel diode step generator, driven by the timing unit just before each sample is taken. Its output is a negative step of about 350 mv, offset by about 200 mv dc into 50 ohms. Risetime is 50 psec or less at the connector.

LOW VOLTAGE POWER SUPPLIES

General

The Type 661 Oscilloscope regulated power supplies are designed for exceptional short- and long-term stability. Sampling circuitry demands current pulses from the -100 -, $+100$ - and $+300$ -volt supplies at irregular intervals. Thus, power supply leads and ground return current paths are carefully planned. All non-constant loads are supplied via individual leads from a common point at the output of the regulator circuits, and most grounds are returned to a common point at each regulator. The $+300$ -volt supply reference tube V719 is temperature isolated for short-term stability. The crt display jitter is maintained at a very low level by use of high-gain feedback amplifiers within each regulator circuit.

Line voltage is applied through fuse F601 and the thermal cutout relay TK601 to the primary windings of the power transformer T601. When the oscilloscope is operated on 117 volts, the fan will remain on in the event the thermal cutout opens. When the oscilloscope is operated on 234 volts, the fan will be turned off in the event the thermal cutout opens. The thermal cutout automatically restores

power to the primary of T601 when the oscilloscope inside temperature drops to a safe level.

Secondary terminals 20 and 21 of T601 energize the thermal time-delay relay K600 that controls the turn-on delay of the low-voltage power supplies when power is applied. As the contacts of K600 close (pins 4 and 9) K601 connects the unregulated supply leads of the -100 -, $+100$ -, and $+300$ -volt supplies to the respective regulator circuits. The -25.2 -, -19 -, and $+19$ -volt regulated supplies are not switched by K601. The -25.2 -volt supply operates at about -25 to -27 volts before K601 is energized. The -19 -volt supply operates at about -1 to -2 volts, and the $+19$ -volt supply operates at about $+15$ volts before K601 is energized.

Voltage reference for the -100 -, -19 -, $+19$ -, $+100$ -, and $+300$ -volt regulated supplies is V719, a gaseous voltage-regulator tube in the $+300$ -volt supply. Voltage reference for the -25.2 -volt regulated supply is a Zener diode, D643, in the -25.2 -volt supply. The -12.6 -volt supply is a shunt regulator utilizing Zener diode D649. This supply floats on the -25.2 -volt supply.

+300-Volt Power Supply

The full-wave bridge rectifier circuit from terminals 9 and 16 of T601 is elevated upon the rectifier system of the $+100$ -volt power supply. The total voltage of the two rectifier systems is about $+455$ volts at normal line voltage. It is used by both the crt high-voltage supply and by the $+300$ -volt regulator system. The total load current of the $+455$ -volt unregulated lead and the $+300$ -volt regulated supply passes through the $+100$ -volt rectifier system.

Voltage-regulator tube V719 maintains a fixed reference voltage of about $+85$ volts at the junction of R718 and R719. R718 is the $+300$ VOLTS adjustment. The voltage at the grid of V716B is obtained from a divider between ground and the $+300$ -volt supply. A small ripple signal from the $+455$ -volt supply is injected at the grid of V716B via a voltage divider and selected resistor R706. R718 ($+300$ VOLTS) is adjusted to set the voltage at the grid of V716A essentially equal to the voltage at the grid of V716B. Thus, V716, A and B, act as a voltage comparator; the A grid voltage (properly set by R718) is the reference for the $+300$ -volt supply.

The voltage at the plate of V716A, about $+200$ volts, is divided by R720-R721 to place the grid of V724 just below ground. V724 amplifies and inverts the signals from V716 and establishes the correct grid voltage for series tube V737, A and B.

If the output voltage changes from $+300$ volts, a sample of the change is applied to the grid of V716B. The error signal is amplified, without phase reversal, by V716A and applied to the grid of V724. V724 amplifies and inverts the error signal, applying it to the grids of V737. V737 is a dual cathode follower; the cathodes follow the grid signal, restoring the $+300$ -volt supply to its correct value.

Circuit Description—Type 661

Capacitors C707 and C720 increase the ac loop gain of the regulator circuit. Their function is to couple high-frequency error signals around the dividers to keep the feedback loop gain uniform with frequency. Thus, the supply will quickly compensate for rapid changes of output voltage. C696B, an electrolytic capacitor, aids in lowering the output impedance of the supply.

To assure minimum ripple and line voltage flutter in the output of the +300-volt supply, a small amount of ripple and line flutter voltage from the +455-volt supply is coupled to the grid of V716B. The value of R706 is selected to minimize the supply output ripple and null out any flutter when the ac line voltage is at its nominal value of 117 or 234 volts.

To assist in stabilizing the +300-volt supply against ripple and line flutter, Zener diode D726 provides a regulated supply voltage for V724. If the unregulated +455-volt bus were to be used as the plate supply voltage for V724, power line flutter would be coupled to the grids of V737 and the +300-volt supply leads.

Resistor R737, in parallel with V737, carries part of the current drawn from the +300-volt supply. R737 also provides for some voltage on the +300-volt supply leads (before the time delay relay closes) to turn on the -25.2-volt supply as soon as the ac power is turned on.

Resistors R731 and R733, located in the cathode circuit of V737, divide the load current between the two halves of the tube, avoiding the possibility of one side being overloaded while the other side does not carry its load share.

Due to careful reduction of ground currents, and by use of the special circuit design just discussed, the +300-volt supply output contains 120-cps ripple of less than 14 millivolts, peak-to-peak. Normal load variations can be as great as 200 ma, ranging from a minimum of 50 ma to a maximum of over 250 ma.

+100-Volt Power Supply

A full-wave bridge rectifier circuit from terminals 7 and 14 of T601 supplies power to the +100-volt regulator circuit and to the +300-volt power supply rectifier system.

A voltage divider, between the +100-volt regulator output and -100-volts, supplies a voltage near ground to the grid of error amplifier V694. If the supply voltage changes, a portion of this change is applied through the divider to the grid of V694. The error signal is then amplified and applied to the grid of series regulator tube V697. The change in voltage at the grid of V697 changes the voltage drop across V697, compensating for the change of the supply voltage.

A small amount of ripple and line flutter from the unregulated lead of the +100-volt rectifiers is coupled to the grid of V694 via selected resistor R694. The ripple and flutter is amplified and used to cancel almost all of the ripple at the output of the regulator. Normal load variations are from a minimum of about 30 ma to a maximum of about 130 ma.

For instruments with serial numbers 900 and above, the output voltage of the +100-volt supply is adjusted by R686.

-100-Volt Power Supply

The -100-volt regulated supply has a comparator-amplifier in the feedback circuit. The greater amount of feedback gain obtained by using both a comparator and a pentode amplifier keeps the output ripple to a value less than about 14 mv with a load of 200 ma or more.

To assure that V624 has an adequate plate supply voltage, neon glow tube B627 serves as a dc step-down to the grids of V637. The plate signal of V624 can then be at a higher dc level than required by the grids of V637, without attenuation of error correcting signals. Capacitor C627 assures that high-frequency correcting signals are not attenuated by the slow following action of B627.

The operation of the regulator circuit is similar to the operation of the +300-volt regulator circuit previously discussed.

-25.2-Volt Power Supply

A full-wave bridge rectifier circuit from terminals 20 and 21 of T601 supplies power to the -25.2-volt regulator circuit. The -25.2-volt regulator then supplies power to the -19-volt power supply and the -12.6-volt Zener diode regulator. The -25.2-volt power supply provides heater current for the vacuum tube feedback amplifiers of the other low voltage regulator circuits (this does not include the series tubes), and is available to the vertical and horizontal plug-in cells.

The output voltage of the -25.2-volt regulator is relatively independent of the other adjustable supplies. The reference voltage for the -25.2-volt supply is the drop across Zener diode D643 and the temperature compensating diode D644, compared to ground, at the emitter-base junction of Q644.

The operating current of D643 is set by R643. A small amount of additional current flows through R644, D644, and R645 to the +300-volt supply. R645 assures a forward bias for Q644, with D644 and D643 acting to limit Q644 current to the correct value.

Normally, the voltage at the base of Q644 rests at about +0.5-volt. If the voltage at the base changes because of a change in the supply voltage, the error signal will be amplified and applied to the base of power transistor Q647. The change in base voltage at Q647 changes the drop across Q647 in a direction to restore the output to normal.

For example, if the supply output starts to go less negative, Q644 will conduct more heavily. This produces a negative drop in the voltage at the collector of Q644 and at the base of Q647. The negative going signal at the base of Q647 causes it to conduct more heavily, reducing its collector-to-emitter voltage and pulling the whole supply in a negative direction to correct for the error.

Diode D644 protects Q644 from large low-impedance positive-going error signals, such as might occur if the supply output lead is accidentally grounded. If the output lead should be grounded, and D644 opens due to its normal inverse bias characteristics, the base current of Q644 is held to a safe limit by R645. As soon as the short is removed

and the output voltage returns negative, D644 will again conduct, restoring normal regulator action. See the Maintenance section of this manual for probable damage and its correction for prolonged periods of short circuit of the -25.2 -volt supply.

Electrolytic capacitor C644 assures that error signals are applied to the base of Q644 without delay, and that Zener diode D643 is not required to pass any high amplitude ac currents.

—19-Volt Power Supply

The -25.2 -volt supply provides power to the -19 -volt regulator circuit. A voltage divider between -19 volts and $+19$ volts provides a voltage near ground to the base of transistor Q654. This voltage is essentially compared to ground in the emitter-base junction of Q654. The emitter of Q654 is held about 0.4 volt above ground by the drop across diode D653. D653 is a first order temperature compensation, causing a small variation to Q654 emitter voltage with variations in temperature to correct for Q654 changes due to temperature.

R656, in the collector leads of Q653 and Q657, acts as a fuse in the event of a heavy overload.

The output voltage of the -19 -volt power supply is adjusted by R651. The output is also sensitive to changes of both the $+300$ - and $+19$ -volt supplies.

Any changes of the output voltage are coupled to the base of Q654 via the divider R650-R651-R652, and by C652. Q654 amplifies the error and applies it as negative feedback to the base of emitter follower Q653. Q653 gives current gain to the correcting signal for the base of series regulator Q657. Q657 acts as an emitter follower for the -19 -volt load, returning the output voltage to normal.

+19-Volt Power Supply

A full-wave bridge rectifier system from terminals 22 and 23 of T601 supplies power to the $+19$ -volt regulator circuit.

Diode D672 gives the $+19$ -volt power supply first order temperature compensation for added stability. R675, in the collector leads of Q673 and Q677, acts as a fuse in the event of a heavy overload.

Reference voltage for the $+19$ -volt supply is adjusted by R666 as part of a voltage divider between the $+300$ -volt supply and ground.

Any changes of the output voltage are coupled to the emitter of Q674 by D672, and compared to the base reference voltage. Q674 amplifies the error signal (in phase) and applies it to emitter follower Q673. Q673 gives current gain to the correcting signal for the base of series regulator Q677. As an example, if a negative error occurs, the correction signal will cause Q677 to decrease the voltage between its emitter and collector, raising the output voltage back to normal.

Probe Power Supply

The -12.6 -volt supply is a shunt regulator floating on the -25.2 -volt supply. Its purpose is to supply 180 ma to

each of the sampling unit PROBE POWER jacks for heaters in cathode-follower signal probes.

CRT CIRCUITS

High-Voltage Power Supply

Unregulated $+455$ volts from the $+300$ -volt power supply is applied to the high-voltage oscillator, V800. V800 and its associated circuitry is a modified Hartley oscillator. C809 and the primary of T801 form a tuned plate circuit for V800. The oscillator operates at approximately 40 kc. High-voltage transformer T801 provides the high voltage and heater voltage for the high-voltage rectifier V822.

The high-voltage secondary winding of T801, and rectifier V822, supplies the high voltage for the crt circuits. A voltage divider between the high voltage and the $+300$ volts supplies proper voltages to the crt cathode, grid, focusing element, and the HIGH VOLTAGE control R841. The voltage at the junction of R841 and R842 is the grid voltage of V814B, to control the output voltage and regulation of the supply. If the high-voltage supply changes from its set value, a portion of the change appears at the grid of V814B as an error signal. The error signal is amplified by V814B and V814A to change the voltage at the screen grid of V800 in the correct direction to compensate for the output error.

Capacitor C842 increases the ac loop gain of the high-voltage regulator circuit. This permits the regulator to compensate quickly for changes in the output voltage.

Crt Intensity Control

Neon glow tubes B847 and B848 provide a low-impedance path from the high-voltage lead to the crt cathode. The glow tubes also establish about 110 volts constant voltage across the INTENSITY control. Changing the setting of the INTENSITY control (R848) will change the crt bias and the display brightness.

Other Crt Voltages

Voltage for the focus element of the crt is obtained from potentiometer R845. Varying R845 adjusts the focus element voltage to permit proper spot focus.

Voltage for the astigmatism element is obtained from potentiometer R864. Varying R864 adjusts the astigmatism element voltage to permit best spot size and trace definition in conjunction with the FOCUS control.

A fixed voltage for the deflection plate isolation shield of about $+160$ volts is obtained from voltage divider R862-R863. This voltage divider is also connected to the crt internal dag coating and is the electron beam return path. The deflection plate isolation shield minimizes the electrostatic fields between the two sets of deflection plates and reduces interaction between the vertical and horizontal systems to insignificance.

Blanking

The oscilloscope uses deflection blanking during the interval that the spot is moved from one sampling dot posi-

Circuit Description—Type 661

tion to the next, and during retrace. The deflection method of blanking uses a special set of deflection plates in the electron gun to divert the electron beam and turn off the display. The crt cathode experiences little or no change in current by the blanking action, because the positive deflection blanking plates accept the cathode current electrons when the display is turned off.

Blanking amplifier V874A rests at cutoff except when the blanking signal turns off the crt beam current. A voltage divider in the grid circuit of V874A sets its grid voltage at about -10 volts. The voltage divider at the plate of V874A holds the plate at about $+170$ volts when the tube is cutoff. Positive-going blanking signals can come from the vertical, the horizontal, or an external digital unit. The blanking signal at the plate of V874A takes the blanking deflection plate (pin 6 of the crt) from about $+170$ volts to about $+50$ volts. The other blanking deflection plate voltage is adjusted to its correct value by the BLANK BAL potentiometer R866. During the time the spot is turned off, R866 and its associated divider accept the crt cathode current.

VERTICAL AMPLIFIER

The Vertical Amplifier receives input signals from the vertical sampling plug-in unit. The amplifier is a current sensitive operational amplifier with a very low input impedance. The amplifier output voltage drives the crt vertical deflection plates and the vertical position indicators. The amplifier sensitivity is calibrated to be about $25 \mu\text{amps/cm}$.

The amplifier consists of two stages; an emitter-coupled paraphase input stage, and a plate-loaded push-pull output stage. The input current to an operational amplifier is always equal to the current in the feedback resistance. The plate voltage of V454A drives the feedback resistance (R472) sufficiently so that the feedback current is $25 \mu\text{amps/cm}$. The vertical amplifier has essentially no series input resistance, therefore its input sensitivity is $25 \mu\text{amps/cm}$. The push-pull output voltage of the amplifier is about 20 volts/cm as required by the crt.

The plate load resistor of V454A is divided for signal take-off to V874B, the vertical beam-position indicator cathode follower. Neon glow tubes B468 and B469 are ignited or extinguished according to the position of the crt spot when off screen. As an example, if the spot is off in a positive direction, the plate voltage of V454A will be somewhat lower than $+130$ volts. The cathode of V874B will be somewhat lower than $+180$ volts, B468 will be glowing and B469 will be dark.

HORIZONTAL AMPLIFIER

The Horizontal Amplifier consists of a three-transistor operational preamplifier, and a two-transistor, two-triode operational output amplifier. The preamplifier drives both the output amplifier and the front-panel horizontal signal output terminal. The preamplifier output signal is 200mv/cm . The output amplifier drives the crt horizontal deflection plates, the horizontal takeoff, and horizontal neon position indicators.

All input signals to the Horizontal Amplifier pass either through terminals 6 and 19, or through terminal 8, of the vertical Interconnecting Socket, J1. Regardless of the type of horizontal presentation (sweep, external signal, X-Y operation), the vertical plug-in unit must be in place in its cell to complete the horizontal input signal path.

The horizontal preamplifier gain is varied from a minimum of 0.04 to a maximum of 4.0 by the HORIZONTAL DISPLAY switch. The input impedance at the base of Q313 is as low as 1 ohm when the magnifier gain is $\times 1$ or the external horizontal deflection factor is 5 volts/cm. The Q313 input impedance rises to a maximum of 100 ohms when the magnifier gain is $\times 100$ or the external horizontal deflection factor is 0.05 volt/cm. Since the input signal passes through R302 (except for X-Y operation), the input impedance then remains at essentially $25,000$ ohms for all amplifier sensitivities. For X-Y operation, the input impedance is that of R303, $3,000$ ohms, giving an increase in gain of 10 to the horizontal system.

Two silicon diodes are connected between the base of Q313 and ground to limit the input signal amplitudes to about ± 0.6 volt. Higher input amplitudes could damage transistors or diodes in the rest of the horizontal amplifier system.

Q313 is an emitter-follower current amplifier, required for its low-impedance drive capabilities by the base of Q324. The collector circuit of Q313 is maintained at $+6.3$ volts by Zener diode D314, aiding in reducing the output impedance of Q313 to the required value. Amplifier Q324 has a first-order temperature compensating germanium diode in its emitter circuit.

Q333 is an output emitter follower required for its low output impedance to drive the feedback resistors, the output amplifier, and the horizontal signal output terminal. Since the emitter of Q333 rests at about -6 volts, and the output circuit of the operational preamplifier must rest near ground, Zener diode D334 alters the output dc level by 6.3 volts without signal attenuation.

The horizontal output amplifier is identical to the vertical output amplifier except its sensitivity is $20 \mu\text{amps/cm}$. In some instruments, the crt *horizontal* deflection factor is adjusted to 16 volts/cm by adjusting the high voltage supply. In others, the horizontal output amplifier gain is adjusted by R359, and the high voltage supply is adjusted to establish the crt *vertical* deflection factor. Since both vertical and horizontal amplifiers are basically low-frequency systems, the horizontal system was given the deflection plates requiring less drive per centimeter but a longer required scan.

Horizontal Takeoff Amplifier

The horizontal system of the Type 661 permits manual or external scanning of the sampling display. (In the MANUAL SCAN positions of the HORIZONTAL DISPLAY switch, the horizontal POSITION control acts as a scan control.) When either manually or externally scanning the display, the horizontal amplifier output voltage is used by the timing unit to control the delay time between triggering and sampling. Voltage from the plate of V364A is fed to the horizontal takeoff amplifier V384, which inverts, attenu-

ates, and adjusts the dc level. The voltage from the takeoff amplifier is used by the timing unit as a fixed fast ramp voltage. Thus, each triggered sample no longer slews along the fast ramp (and the display), but is held at a fixed point by the level of the takeoff voltage. Rotating the POSITION control changes the takeoff voltage to the timing unit, much the same as if the timing unit fast ramp voltage were functioning in a normal manner. (See the instruction manual for the timing unit in use.) The position of the manually or externally scanned displays is made to agree with the normal timing unit scanned display by means of R378, the HORIZ. TAKEOFF DC LEVEL control. The takeoff amplifier voltage gain is calibrated to be about 0.6.

The horizontal beam position indicators are controlled by the voltage at the plate of V384A.

AMPLITUDE/TIME CALIBRATOR, S/N 101-1999

The Amplitude/Time Calibrator is a modified Colpitts oscillator with four amplitude and frequency settings. V930 forms a parallel triode oscillator. Adjustment of feedback voltage from the cathode of V930 aids in establishing the correct output amplitude. For the 10, 1, and .1 positions of the $\mu\text{SEC}/\text{CYCLE}$ switch, the grid voltage of V930 is limited in amplitude by the emitter voltage of Q953. The voltage at the emitter of Q953 does not materially affect the output amplitude when the $\mu\text{SEC}/\text{CYCLE}$ switch is in the .01 position.

V930 grid voltage limiting centers about ground potential. The emitter voltage of Q953 is adjusted during calibration to a value near +14 volts. Thus, diodes D942 and D952 conduct alternately when the voltage at their junction reaches ground and +14 volts. C941 thus maintains a nominal charge of 7 volts, permitting the grid of V930 to swing freely from about -7 to $+7$ volts each cycle. The oscillator feedback is high enough to drive the grid of V930 more than ± 7 volts, thus diodes D942 and D952 limit the grid swing and the output amplitude.

The output circuit of the oscillator is capacitively coupled to a load of about 230 ohms made up of R976 in series with the two terminating resistors (R977-R978) and a 50-ohm four-position attenuator. The mV AMPLITUDE control switches in appropriate 50-ohm attenuators so that the oscillator amplitude can remain constant while the output connector receives the correct amplitude at the correct impedance.

A second oscillator output is taken through isolation resistor R966 to the timing unit for internally triggering the sampling display. This feature is particularly important when the vertical plug-in unit does not have triggering circuitry, or when the calibrator signal is less than that required by the vertical plug-in unit for proper internal trigger pickoff. Because of this signal, the calibrator should be turned off when not in use. If the calibrator is left on, there may be triggering interference due to stray coupling in the timing unit.

AMPLITUDE/TIME CALIBRATOR, S/N 2000-UP

The Amplitude/Time Calibrator is a transistorized Colpitts oscillator with four output amplitudes from 1 mv to 1 volt and four output frequencies from 100 kc to 100 mc. The calibrated amplitudes and frequencies are in decade steps.

Selection of the output frequency is provided by resonant circuits that can be switched into the base-emitter circuit of Q930 by SW910, the front-panel $\mu\text{SEC}/\text{CYCLE}$ switch. Each resonant circuit consists of fixed capacitors and an inductor that is variable for frequency adjustment. At the .01 μsec position (100 mc), the resonant circuit consists of the capacitance of C934 and C935 and the inductance of L916 and its associated leads.

Excursion of the oscillator sine-wave output is from about -5 volts to $+5$ volts, set primarily by clamp diodes D930. Feedback current to the oscillator is adjusted by R942 (OSC. FEEDBACK), and at the high frequencies C942 assists in providing oscillator feedback. For the 100 mc output (.01 $\mu\text{SEC}/\text{CYCLE}$), L955, R955 and C956 form a critically damped LRC circuit to insure a sinusoidal drive for the current-switching diode stage.

Current-switching diodes D958 and D959 receive approximately 40 ma of current from the -100 -volt supply through R967, R965 and R964. At the .01 position of the $\mu\text{SEC}/\text{CYCLE}$ switch, current is increased by shorting out R967. With the oscillator turned off, current is divided equally between the two diodes, with R962 (SYMMETRY) correctly adjusted. When the oscillator is operating, its sine-wave output is applied to the anode of D958. On the positive swing, current increases through D958 until the diode is conducting all of the 40 ma and D959 is cut off. The output level is at zero volts at that time. On the negative oscillator swing, current decreases through D958 until it cuts off and the 40 ma is conducted through D959 and the $25\ \Omega$ load. The output level is then at -1 volt. Thus the clipped sine-wave output has a peak-to-peak amplitude of one volt. Corrective networks provide compensation for circuit and diode capacitance in the current-switching stage. R970, L970 and C971 provide compensation for the 10 mc signal. R968 and C968 compensate the 100 mc waveform. L958 and L970 are self resonant at 100 mc to reduce losses caused by L960 and the 10-mc compensation network. Adjustments in these circuits are set to produce the best possible wave-shape of the clipped sine-wave output.

The output from the diode stage is applied to a network of three 50-ohm $10\times$ attenuators that can be connected in series with the load to produce the desired output amplitude. Attenuation of the 1-volt calibrator signal is selected by SW980, the front-panel mV AMPLITUDE switch.

A second output from the oscillator circuit is taken through isolation resistor R954 to the timing unit for internally triggering the sampling display. This feature is particularly useful for observing the calibrator signal when the vertical plug-in unit does not have a trigger takeoff or when the calibrator signal is of low amplitude. The internal calibrator trigger has the same amplitude (about 100 mv) regardless of the position of the mV AMPLITUDE switch. Because of this signal, the calibrator should be turned off when not in use to avoid triggering interference through stray coupling in the timing unit.

DELAYED PULSE GENERATOR

The Delayed Pulse Generator employs a strip-line 50-ma tunnel diode to deliver a fast negative-going pulse to a 50-ohm load (at the DELAYED PULSE $50\ \Omega$ connector). Tunnel diode switching voltage comes from the timing unit plug-in.

Circuit Description—Type 661

Static operating bias is obtained from the voltage drop across R990, the internal DELAYED PULSE GEN. BIAS control. Current for R990 comes from the -25.2 -volt supply through the heaters of V694 and V814.

The tunnel diode is switched from its low-voltage state to its high-voltage state each time the timing unit is trig-

gered. Thus, the negative step can be made to appear as a stable crt display regardless of the sweep rate. If the timing unit is triggered, the delay pulse repetition rate is the same as that of the signal (up to a maximum determined by the count-down rate of the timing unit). If the timing unit is free running, the delayed pulse will appear at the free-run rate.

SECTION 4

MAINTENANCE

PREVENTIVE MAINTENANCE

Air Filter

The Type 661 Oscilloscope is cooled by air drawn through a washable filter at the rear of the instrument. The filter is constructed of aluminum wool treated with a dust adhesive. If the filter becomes excessively dirty, it will restrict the flow of air into the instrument and may cause overheating. High internal temperatures will not only reduce component life, but may also cause the thermal cutout to open at a crucial point in an experiment. If the thermal cutout opens, the filter should be checked immediately.

The filter should be visually checked every few weeks. It should be cleaned at least every three or four months, more often if required. To clean the filter, first remove the loose dirt by tapping the filter gently on a hard surface. Then wash the filter by running hot soapy water through it until it is clean, rinse, and allow to dry. Then coat the filter with an adhesive such as "Handi-Koter" or "Filter-coat" (products of the Research Products Corporation, Tektronix part no. 006-580). These products are generally available from air-conditioner suppliers.

Cleaning the Exterior

Loose dust accumulating on the outside of the Type 661 can be removed with a cloth or small paint brush. The paint brush is particularly useful for dislodging dust on and around the front-panel controls. Stubborn dirt can be removed with a soft cloth dampened in a solution of water and mild detergent. Abrasive cleaners should not be used.

Clean the graticule and the face of the crt with a soft, lint-free cloth dampened with an alcohol, such as isopropanol, that has not been denatured.

CAUTION

Do not clean any plastic materials with organic chemical solvents such as benzene, acetone or denatured alcohol. These solvents might damage the plastics.

Removal of Panels

The side and bottom panels of the Type 661 can be removed separately for maintenance work. The panels are held in place by coin-slotted screwhead fasteners. To remove them, use a screwdriver or coin to rotate the fasteners approximately two turns counterclockwise. Then pull the upper portion of the panels outward from the carrying handles.

Cleaning the Interior

Although air entering the Type 661 is filtered, some dust may penetrate into the interior of the instrument. This dust should be removed occasionally to prevent instrument

failures due to its conductivity under high humidity conditions. The best way to keep the interior of the instrument clean is to blow away the dust with compressed air. Avoid using high-velocity air to prevent damage to some of the components. Remove stubborn dirt with a soft paint brush or a cloth dampened with a water and mild detergent solution.

Pay special attention to the high-voltage circuits, including parts inside the high-voltage shield. Accumulated dust should be removed, since dust combined with high humidity can produce high-voltage arcing. Arcing may cause false sweep triggering with a resultant unstable crt display.

Visual Inspection

Troubles can sometimes be found by a visual inspection of the instrument. For this reason, you should perform a complete visual check every time the instrument is calibrated or repaired. Look for such defects as loose or broken connections, loose set screws in the knobs or shaft couplers, damaged connectors, improperly seated tubes or transistors, scorched or burned parts, broken terminal strips, etc. Except for heat-damaged parts, the remedy for most of these troubles is apparent. Heat damage is often the result of other, less apparent, defects in the circuit. It is essential for you to determine the cause of overheating before replacing damaged parts.

Fan Motor

The fan motor bearings are factory lubricated. No additional lubrication is required for the life of the instrument.

Tube Checks

Tube-tester checks on the tubes used in the Type 661 Oscilloscope are not recommended. Tube testers may indicate a tube to be defective when that tube is operating satisfactorily in a circuit, or they may fail to indicate tube defects which affect the performance of the circuits. We recommend that tubes be checked by substitution. If the tube is good, return it to its socket. Unnecessary replacement of tubes is not only expensive but may also result in needless recalibration of the instrument.

Recalibration

The Type 661 Oscilloscope is a stable instrument that will provide many hours of trouble-free operation. However, to insure that the unit is operating properly at all times, we suggest that you recalibrate the instrument after each 500 hours of operation (or every six months if used intermittently). A complete step-by-step procedure for calibrating the instrument and checking its operation is given in Section 5 of this manual.

REMOVAL AND REPLACEMENT OF PARTS

General Information

Most parts in the Type 661 Oscilloscope can be replaced without detailed instructions. Other parts, however, can best be removed if a definite procedure is followed. Instructions for the removal of some of these parts are contained in the following paragraphs. Because of the nature of the instrument, replacement of certain parts will require that you recalibrate portions of the oscilloscope to insure proper operation. Refer to Section 5 of this manual for the applicable calibration steps.

Replacement of Cathode-Ray Tube

WARNING

Use care when handling a crt. Avoid striking it on any object that might cause it to crack and implode. Flying glass from an imploding crt can cause serious injury. Use safety glasses or a plastic face mask for protection.

To remove the cathode-ray tube, carefully remove all leads connected to the neck of the tube and disconnect the tube socket at the rear of the tube. Loosen the base clamp and remove the graticule. Pull the crt straight out through the front panel. Do not strike any of the neck pins on the inside of the crt shield in the replacement process.

Carefully slip the new crt into position. Place the graticule over the crt face with the scribed lines on the inside, toward the phosphor. Then place the four rubber washers over the four graticule mounting studs. Replace the graticule cover and secure it in place with the four knurled nuts. Position the crt with the neck-pins centered in the corresponding holes in the crt shield, then tighten the base clamp. Following the color code information on the tube shield, connect the leads to the crt pins and connect the tube socket at the rear of the tube. After replacement of the crt, it will be necessary to recalibrate certain portions of the oscilloscope. Special attention should be given to the horizontal and vertical amplifier sensitivities (see steps 8 through 12 in the Calibration Procedure).

In replacing the graticule, if you use a Tektronix camera-mounting bezel, do not place the four rubber washers between it and the graticule.

NOTE

New type cathode-ray tubes for the Type 661 will not permit proper vertical and horizontal gain settings in the instruments having serial numbers lower than 310. (Instruments with serial number 310 and above have a variable horizontal gain control.) If the serial number of your instrument is below 310, we advise you to order Type 661 Mod 050-071 (no charge) at the time you order your first new cathode-ray tube. This modification will permit the horizontal and vertical amplifiers of the Type 661 to be properly adjusted to the deflection sensitivities of the new crt. The Calibration Procedure in this manual will allow proper calibration after Mod 050-071 has been installed.

Replacement of Switches

Methods for removal of defective switches are, for the most part, obvious, and only a normal amount of care is required. Single wafers are normally not replaced in the switches used in the Type 661. If one wafer is defective, the entire switch should be replaced. Most switches can be ordered either wired or unwired, as desired. See the Parts List for parts ordering information.

Tube Replacements

Care should be taken that tubes are not replaced unless they are actually causing trouble. Occasionally it will be necessary for you to remove tubes from their sockets. It is important that these tubes be returned to the same sockets unless they are actually defective. Unnecessary replacement or switching of tubes will often force recalibration of the instrument. If tubes do require replacement, it is recommended that they be replaced by previously checked high-quality tubes. Check the Parts List before ordering replacements.

Soldering Precautions

In the production of Tektronix instruments a special silver-bearing solder is used to establish a bond to the ceramic terminal strips. This bond may be broken by repeated use of ordinary tin-lead solder, or by excessive heating of the terminal strip with a soldering iron. Occasional use of ordinary 60-40 solder will not break the bond unless excessive heat is applied.

If you are responsible for the maintenance of Tektronix instruments, it is advisable to have a stock of solder containing about 3% silver. It may be purchased directly from Tektronix in one-pound rolls; order by part number 251-514.

Because of the shape of the terminals of the ceramic terminal strips, we recommend a wedge-shaped tip on your soldering iron. These tips allow you to apply heat directly to the solder in the terminals and reduces the amount of heat required. It is important to use as little heat as possible while producing a full-flow joint.

When removing or replacing components mounted on the ceramic strips, satisfactory results can be obtained if you proceed in the following manner:

1. Use a soldering iron of 50- to 70-watt rating.
2. Tin the tip with solder containing about 3% silver.
3. Apply one corner of the tip to the notch where you wish to solder.
4. Apply only enough heat to make the solder flow freely.
5. Do not attempt to fill the notch on the strip with solder; instead apply only enough solder to cover the wires adequately, and to form a small fillet on the wire. If the lead extends beyond the solder joint, clip the excess as close to the joint as possible. Remove all wire clippings from the chassis.

In soldering to metal terminals (for example, pins on a tube socket) a slightly different technique should be employed. Prepare the iron as described, and apply the iron to the part to be soldered. Use only enough heat to allow

the solder to flow freely along the wire so that a small fillet will be formed.

Ceramic Strips

Damaged ceramic strips are most easily removed by unsoldering all connections, then using a plastic or hard-rubber mallet to knock the plastic yokes out of the chassis. This can be done by using the mallet to hit the ends of the yokes protruding through the chassis. The strip with the two yokes can then be removed as a unit. The spacers will probably come out with the yokes; if not, they can be removed separately.

Another way of removing the terminal strip is to cut off the side of the yoke with diagonal cutters. This permits the strip to be removed from a difficult area where a mallet cannot be used. The remainder of the yokes and the spacers can be pulled out separately. Since a replacement strip is supplied with yokes already attached, the old yokes need not be salvaged. However, the old spacers can probably be used again.

When the damaged strip and yoke assembly has been removed, place the spacers into the holes in the chassis. Then set the ends of the yoke pins into the spacers. Then press or tap lightly directly above the yokes to drive the yoke pins down through the spacers. Be certain that the yoke pins are driven completely through the spacers. Then cut off the portion of the yoke pin protruding through the spacers. Fig. 4-1 shows how the ceramic strip parts fit together.

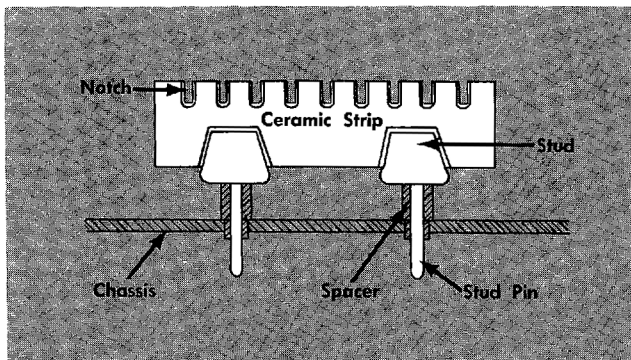

Fig. 4-1. Ceramic strip assembly.

TROUBLESHOOTING

General Troubleshooting Information

This portion of the instruction manual is intended to help you troubleshoot the Type 661 in the event of trouble.

If trouble occurs, attempt to isolate it by quick operational and visual checks. You should first check the settings of all controls on the indicator and plug-in units. Then operate the controls to see what effect, if any, they have on the trouble. The normal or abnormal operation of a control may help you to establish the trouble symptoms.

The first step required in troubleshooting the system is to determine if the trouble is in the Type 661 or in one of the plug-in units. The fastest and best way to determine this is by substituting other plug-in units in the oscilloscope. If other plug-in units are not available, a quick check can

be made by measuring the output and ripple voltages of each regulated power supply and by checking the operation of the crt circuit. Table 5-1 of the Calibration Procedure lists normal resistances to ground for each power supply lead. If the regulated power supplies and the crt circuit appear to be working properly, the trouble is most likely in one of the plug-in units. In this case, refer to the appropriate plug-in unit instruction manual for troubleshooting information. If the regulated power supplies or the crt circuit are not operating correctly, the trouble is probably in the Type 661.

Most troubles that occur in Tektronix instruments result from the failure of vacuum tubes or semiconductors. Therefore, if trouble occurs, tubes and semiconductors should be checked as one of the first steps. It is preferable to check them by substitution rather than with a tester, since testers frequently fail to indicate certain troubles which can affect oscilloscope performance. When a tube or semiconductor develops a short, associated components can be damaged.

To aid in troubleshooting the Type 661, typical voltages are indicated on the circuit diagrams. These voltages may vary slightly from instrument to instrument but should be quite close to the indicated values.

All wiring used in the Type 661 is color coded to facilitate circuit tracing. In addition, all regulated power supply leads are coded with specific color combinations for easy identification. In general, three stripes are placed on the wires of the regulated supplies. The first color (widest stripe) indicates the first number of the voltage on that lead using the standard EIA number-color code. The second color indicates the second number of the lead voltage and the third color is a multiplier. The method is similar to the color coding of resistors. Thus, the +100-volt leads are coded brown, black, brown. The voltage is positive if the main color of the wire is white and negative if the main color of the wire is black.

Reference voltage for most of the low-voltage power supplies is obtained from the +300-volt supply. Therefore, if the +300-volt supply is not operating properly, operation of the other low-voltage supplies will be affected. For this reason it is important, when trouble is detected in the low-voltage power supply, to check the +300-volt supply first. If the output of the +300-volt supply is correct, then troubleshoot the power supply where the trouble was first evident.

If the instrument is not operating, check the simple things first. Be sure the power cord is plugged in and that there is power at the socket. Check that the tube heaters are lit and the graticule illumination lamps are operating properly. If necessary check the line fuse. When the simple possibilities have been checked, proceed to a more detailed analysis of the trouble.

Circuit Troubleshooting

As an aid to relating troubles and their probable causes, troubleshooting Table 4-1 is included. This table lists the troubles which are most likely to occur in the instrument and instructions for correcting them. If trouble occurs, the symptoms can be used to find the appropriate section of Table 4-1.

Voltages listed in the table were obtained with the Type 661 operated with the Types 4S1 and 5T1A Plug-In Units. Fig. 5-1 shows the location of the power supply test points.

TABLE 4-1

SYMPTOMS	PROBABLE CAUSES	CHECKS TO MAKE
+300-Volt Power Supply		
<p>1. Output voltage slightly higher or lower than normal but regulates with changes in line voltage. (May not regulate over full range of 105 to 125 volts.)</p>	<p>Improper setting of R718. Abnormal voltage across V719. R707, R708, R720, or R721 changed in value. R737 may be open.</p>	<p>1. Use the +300 VOLTS control to try and set the output voltage to normal. 2. Check for regulation with line voltage varied from 105 to 125 volts. Check output ripple voltage. If normal, trouble is corrected. 3. Check for about 85 volts across V719.</p>
<p>2. Output voltage appreciably higher than normal, and does not regulate with changes in line voltage.</p>	<p>V719 open. V724 not conducting. R707, R720, R723 open. -25.2-volt supply dead.</p>	<p>1. Check for about 85 volts across V719. 2. Check that heaters of V716 and V724 are glowing. If not, check -25.2-volt supply. If -25.2-volt supply okay, check individual tube heaters—they are in series. 3. Check voltage at pin 7, V716. If zero, R707 is open. 4. Check voltage at pin 1, V724. If -100 volts, R720 is open. 5. Check for about +98 volts at pin 6, V724.</p>
<p>3. Output voltage appreciably lower than normal, and does not regulate with changes in line voltage.</p>	<p>R680, R681, R700, R708, R719, R721, R737 open. C682, C696B, C702, C707, C716, C720 shorted. Either side V737 not conducting. R731 and/or R733 open. +100-volt rectifiers dead.</p>	<p>1. Check voltage at pin 7, V716. If high, R708 is open, or C707 is shorted. 2. Check voltage at pin 1, V724. If slightly positive, C720 is shorted or R721 is open. 3. Check voltage at pin 2, V716. If zero, C716 is shorted or R719 is open. 4. Check V737. If one plate is red, other side is not conducting. Then check R731 and R733. If both resistors are burned, check C696B for short. If C696B okay, check for possible short in one of the plug-in units. Remove plug-ins, replace burned resistors, turn on power again, and check output voltage. If normal, fault is in a plug-in unit. 5. Check voltage at output of +100- and +300-volt rectifiers. Check C682, C702, R680, R681 and R700. If C682 or C702 is shorted, check rectifiers for shorts.</p>
<p>4. Excessive ripple on output. Appears to regulate over normal voltage limits.</p>	<p>R704, R706, open. D726 either open or shorted. V716, V724.</p>	<p>1. Check for +330 volts at junction of D726 and R726-R727. 2. Check value of R704 and R706. 3. Replace tubes.</p>
+100-Volt Power Supply		
<p>1. Output voltage slightly higher or lower than normal, but regulates with changes in line voltage. (May not regulate over full range of 105 to 125 volts.)</p> <p>2. Output voltage appreciably higher than normal, and does not regulate with changes in line voltage.</p>	<p>R684 or R685 have changed value. C684 leaky, but not shorted.</p> <p>R684 open. -100-volt supply excessively negative and not regulating. V694 not conducting.</p>	<p>1. Check R684 and R685 with a good resistance bridge. Check C684 for resistance.</p> <p>1. Check V694 for heater glow. If not glowing, check -25.2-volt supply and V814 heater (V694 and V814 heaters are in series and grounded through the DELAYED PULSE circuit). 2. Check R684. 3. Check -100-volt supply output.</p>

TABLE 4-1 (cont'd)
+100-Volt Power Supply (Cont'd)

SYMPTOMS	PROBABLE CAUSES	CHECKS TO MAKE
<p>3. Output voltage appreciably lower than normal, and does not regulate with changes in line voltage.</p> <p>4. Excessive ripple on output. Appears to regulate over normal line voltage limits.</p>	<p>Output of —100-volt supply low. R680, R681, R685 open. C682, C684 shorted. Excessive load. V697. D682 (A,B,C,D) open or shorted.</p> <p>Ripple might be feedback into supply from Amplitude/Time Calibrator. If ripple is twice the line frequency, R694 may be open. Output from rectifiers may be low. V694 or V697.</p>	<p>1. Check output of —100-volt supply.</p> <p>2. Check D682, C682, C684, R680, R681, R685.</p> <p>3. Change V697.</p> <p>4. Remove plug-in units and recheck output voltage. If normal, check for excessive load in a plug-in.</p> <p>1. Turn off Amplitude/Time Calibrator.</p> <p>2. Check R694. If open, follow calibration procedure for proper replacement.</p> <p>3. Check voltage at plate of V697. If low, check R680 and R681.</p> <p>4. Change tubes.</p>
—100-Volt Power Supply		
<p>1. Output voltage slightly higher than normal, but regulates with changes in line voltage. (May not regulate over full range of 105 to 125 volts.)</p> <p>2. Output voltage appreciably more negative than normal, and does not regulate with changes in line voltage.</p> <p>3. Output voltage appreciably less negative than normal, and does not regulate with changes in line voltage.</p> <p>4. Excessive ripple on output. Appears to regulate over normal line voltage limits.</p>	<p>R610, R612, R620, R621 changed value. V616, V624, V637.</p> <p>R612, R620, R623 open. V624. C627 shorted and B627 dark.</p> <p>R610, R621, R631, R633 open. C602, C636, C620 shorted. R600 or D602 diodes open. Plug-in unit overload. V616, V624, V637.</p> <p>C636, V616, V624, V637. —25.2-volt supply voltage low so heaters of V624 and V616 are not hot enough. R616 increased in value.</p>	<p>1. Check R610, R612, R620, R621 with a good resistance bridge.</p> <p>2. Replace tubes.</p> <p>3. Check output +300-volt and +100-volt supply. If out of tolerance, correct and recheck —100-volt supply.</p> <p>1. Check R612, R620, R623.</p> <p>2. Check for heater glow in V616 and V624 (heaters in series).</p> <p>3. Check output of —25.2-volt supply.</p> <p>4. Check C627.</p> <p>1. Check R610 and R621.</p> <p>2. Check C602, C620, C636.</p> <p>3. Check R631 and R633. If open, check for shorts.</p> <p>4. Check rectifier circuit and its output voltage.</p> <p>5. Remove both plug-in units and recheck voltage. If normal, overload is in plug-in.</p> <p>6. Replace tubes.</p> <p>1. Check C636.</p> <p>2. Change tubes.</p> <p>3. Check voltage of —25.2-volt supply.</p> <p>4. Check R616.</p>
—25.2-Volt Power Supply		
<p>1. Output voltage appreciably higher than normal, and will not regulate with line voltage changes.</p> <p>2. Output voltage appreciably lower than normal, and will not regulate with line voltage changes.</p>	<p>D644 open. D643, C644 shorted. Q644, Q647 shorted between collector and emitter.</p> <p>R640, R641, R648 open. C642, C646 shorted. One or more of D642 diodes shorted.</p>	<p>1. D644 acts as a fuse if D643 or C644 shorts (check both). If D643 shorts, there will probably be no damage other than D644 opening.</p> <p>2. Replace Q644.</p> <p>1. Check R648. If open, also check Q647 for a short.</p> <p>2. Check R640 and R641. If open, relay K601 will not close, and there will be no dc output from —25.2-volt supply. Look for load short, or other short such as C642.</p> <p>3. Check C646.</p> <p>4. Check D642 diodes.</p>

TABLE 4-1 (cont'd)
 —25.2-Volt Power Supply (Cont'd)

SYMPTOMS	PROBABLE CAUSES	CHECKS TO MAKE
3. Output voltage slightly more negative than normal, but will regulate with line voltage changes. 4. Output voltage slightly less negative than normal, but will regulate with line voltage changes. 5. Excessive ripple on output. Appears to regulate over normal line voltage limits. 6. Excessive ripple on output. Regulates only at high line voltage.	R644 high in value. R645 low in value. C644 leaking. R643 increased in value. C642, C644, C646 changed value. Power supply overloaded. Q644 Beta unusually low. One diode of D642 open.	1. Check R644 and R645. 1. Check C644 for resistance. 2. Check R643. 1. Check C642, C644, C646. 2. Check for overload in plug-in units (if they use the —25.2-volt supply). 3. Check Q644. Check D642 diodes.
—19-Volt Power Supply		
1. Output voltage slightly higher or lower than normal but regulates with changes in line voltage. 2. Output voltage appreciably less negative than normal, and will not regulate with line voltage changes. 3. Output voltage appreciably more negative than normal.	Improper setting of R651. C652 leaking. +19-volt supply voltage out of tolerance. +300-volt supply voltage out of tolerance. C652, C656 shorted. D653 open. R656 open. Q654 shorted. —25.2-volt supply output low. Q653, Q657 shorted.	1. Readjust R651, the —19 VOLTS control, to set the output voltage to normal. 2. Check C652. 3. Check output voltage of both +300- and +19-volt supplies. 1. Check C652, C656, D653. 2. Check R656; then look for load shorts, such as the vertical plug-in tube heater circuit. 3. Replace Q654. Check Q653, Q657 with ohmmeter. Use R×10 or R×100 scale, not R×1 scale.
+19-Volt Power Supply		
1. Output voltage slightly higher or lower than normal but regulates with changes in line voltage. 2. Output voltage appreciably higher than normal. Does not regulate with line voltage changes. 3. Output voltage appreciably lower than normal. Does not regulate with line voltage changes.	+300-volt supply voltage out of tolerance. Improper setting of R666, the +19 VOLTS control. C668 leaking. C662 low in capacitance. Q673, Q677 shorted. D672 open. Q674 shorted. C662, C668, C676 shorted. D662 diodes open or shorted. R660, R675 open. —25.2-volt supply dead and K601 not energized. +300-volt supply dead.	1. Check output of +300-volt supply. 2. Readjust R666, the +19 VOLTS control, to set output to normal. 3. Check C668. 4. Check C662. If low, output ripple may be slightly high. Check Q673, Q677 with ohmmeter. Use R×10 or R×100 scale. Check each of the probable causes.
CRT CIRCUIT AND HIGH VOLTAGE POWER SUPPLY		
1. No high voltage at the crt cathode.	Oscillator not operating. T801 defective. V822 defective. R803, R849 open. C803, C822, C842 shorted.	1. Check heater of V822. If glowing, oscillator is operating. 2. Check voltage at plate of V822; should be about —3000 volts. 3. Check C822. 4. Check V822; if necessary, check windings of T801. 5. Check plate voltage of V800; should be about +420 volts. 6. Check screen voltage of V800; should be about +60 volts. 7. Check C803, C842.

TABLE 4-1 (cont'd)

CRT CIRCUIT AND HIGH VOLTAGE POWER SUPPLY (Cont'd)

SYMPTOMS	PROBABLE CAUSES	CHECKS TO MAKE
<p>2. No control of crt intensity. Spot is on and bright.</p> <p>3. High voltage does not regulate with change in line voltage, or cannot be set to proper level.</p> <p>4. Spot or trace dim at left of crt and about normal at right of crt, with INTENSITY control fully clockwise.</p> <p>5. High voltage normal but no spot or trace.</p>	<p>C850 shorted.</p> <p>V814 inoperative. C841 shorted. R815 open.</p> <p>R866 fully clockwise.</p> <p>C867, C874 shorted. Defective crt. R847, R871 open. Defective INTENSITY control.</p>	<p>Check C850. If shorted, B847 and B848 will extinguish when INTENSITY control is turned fully counterclockwise.</p> <p>1. Pin 7, V814, should be about -110 volts. 2. Pins 2 and 6, V814, should be about -3 volts.</p> <p>Adjust R866, BAL. BLANK control, according to Calibration Procedure.</p> <p>1. Check voltages at crt pins 6 and 7. 2. Check resistance across B847 and B858; should be about 2 meg. 3. Check crt for heater glow. 4. Check R871. 5. Turning the INTENSITY control clockwise for bright trace should increase brilliance of B847 and B848 if crt cathode is emitting normally.</p>
VERTICAL AMPLIFIER		
<p>1. Trace centered, but cannot be moved vertically. Horizontal is working, but appears to be about 1 cm short. Spot is brighter than normal.</p> <p>2. Trace centered, but cannot be moved vertically. Horizontal and spot brilliance normal.</p> <p>3. Trace vertical movement is limited to less than full screen. Trace cannot be moved off top or bottom of crt.</p>	<p>R449 open. V454 heater open.</p> <p>R409 open. Q404 and Q414 shorted. Plug-in unit defective.</p> <p>R477, VERT. DC BAL. out of adjustment. Plug-in unit defective.</p>	<p>1. Check R449. 2. Replace V454.</p> <p>1. Check R409. 2. Check Q404 and Q414. 3. Touch either end of R401 with a meter test lead. If normal hum shows on display, trouble is in plug-in unit.</p> <p>1. Remove vertical plug-in unit. Turn scope on. If trace is not near crt center, follow Calibration Procedure for VERT. DC BAL. control. 2. If vertical dc balance is normal, see plug-in manual for troubleshooting aids.</p>
HORIZONTAL AMPLIFIER		
<p>1. Spot or vertical trace centered horizontally. Focus fuzzy at normal FOCUS control position. Cannot move spot horizontally.</p> <p>2. Spot or vertical trace centered horizontally, but cannot position horizontally. Focus okay.</p> <p>3. Horizontal POSITION control cannot properly center trace or spot.</p>	<p>R364 open. V364 heater open.</p> <p>R349 open. Q344 and Q354 shorted.</p> <p>HORIZ. DC BAL. control out of adjustment. Timing unit defective.</p>	<p>1. Check R364. 2. Replace V364.</p> <p>1. Check R349. 2. Check Q344 and Q354.</p> <p>1. Remove both plug-in units. Turn scope on. If spot is not near the crt center with various SWEEP MAGNIFIER positions, see calibration procedure for HORIZ. DC BAL. adjustment. 2. If HORIZ. DC BAL. adjustment is normal, see plug-in manual for troubleshooting aids.</p>

TABLE 4-1 (cont'd)
HORIZONTAL AMPLIFIER (Cont'd)

SYMPTOMS	PROBABLE CAUSES	CHECKS TO MAKE
<p>4. Trace or spot off crt to the right.</p> <p>5. Trace or spot off crt to the left.</p> <p>6. Trace begins at about the sixth cm. Horizontal POSITION control can crowd whole trace into one spot when rotated counterclockwise.</p> <p>7. Display of vertical signal spread over about 2.5 cm horizontally in a smeared appearance.</p>	<p>D323 open. Timing unit defective.</p> <p>Q324 shorted. Timing unit defective.</p> <p>D334 shorted.</p> <p>D314 shorted.</p>	<p>Check D323. D323 acts as fuse for overload conditions in emitter of Q324. If D323 satisfactory, see timing unit manual for troubleshooting aids.</p> <p>Check Q324 collector voltage. If near ground, replace Q324. If Q324 satisfactory, see timing unit manual for troubleshooting aids.</p> <p>Check D334.</p> <p>Check voltage at Q313 collector. If at ground, replace D314.</p>
<p>AMPLITUDE/TIME CALIBRATOR S/N 101-1999</p>		
<p>If trouble occurs in the AMPLITUDE/TIME CALIBRATOR, the first step is to check the calibration of the Calibrator. If calibration adjustments do not solve the problem, proceed with regular servicing techniques.</p>		
<p>1. No output on any of the μSEC/CYCLE switch positions.</p> <p>2. Output amplitude is low, except at .01 μSEC/CYCLE.</p> <p>3. Cannot trigger display on calibrator output at 1 and 10 mV AMPLITUDE.</p>	<p>V930 inoperative. Q953 defective.</p> <p>R959, AMPL. LIMIT control, incorrectly adjusted.</p> <p>Use Timing unit trigger SOURCE switch at CAL.</p>	<p>1. Replace V930. 2. Replace Q953.</p> <p>See Calibration Procedure for AMPL. LIMIT control.</p>
<p>AMPLITUDE/TIME CALIBRATOR S/N 2000-UP</p>		
<p>1. No output on any of the μSEC/CYCLE positions.</p> <p>2. Sloping top and bottom of waveform display.</p> <p>3. Incorrect display amplitude on all positions of μSEC/CYCLE switch.</p> <p>4. Incorrect output amplitude only at .01 μSEC/CYCLE position.</p>	<p>Q930 inoperative. D948 and D959 inoperative.</p> <p>Losses in input cable or vertical plug-in unit. Improper adjustment of C968 or C971.</p> <p>Vertical gain out of adjustment. R965 misadjusted. Output impedance not 50 Ω.</p> <p>R967 misadjusted. Losses in transmission system between calibrator output and vertical input.</p>	<p>Check adjustment of R942 according to the calibration procedure. If no oscillator output, replace Q930. Check adjustment of R967, R965. If still no output, replace D958 and D959.</p> <p>1. See typical calibrator waveforms in Section 2, Operating Instructions. 2. Adjust the appropriate capacitor as described in the calibration procedure (Amplitude/Time Calibrator). Check the corresponding amplitude and frequency after this adjustment.</p> <p>1. See First Time Operation in Section 2. 2. Adjust R965 according to calibration procedure. 3. Check that the Calibrator output is terminated with a 50 Ω load.</p> <p>1. Adjust R967 according to calibration procedure. 2. Use minimum length of 50 Ω cables or other coupling devices.</p>
<p>DELAYED PULSE 50 Ω</p>		
<p>1. No output step.</p>	<p>D992 defective. R990, DELAYED PULSE GEN. BIAS control, incorrectly adjusted.</p>	<p>1. Try adjusting R990, the DELAYED PULSE GEN. BIAS control, according to the Calibration Procedure. If still no output, replace D992. 2. With test oscilloscope, see if Timing unit is properly driving tunnel diode D992.</p>

SECTION 5

CALIBRATION

INTRODUCTION

The following paragraphs outline the procedure used to calibrate the Type 661 Oscilloscope. The instrument should not require frequent recalibration, but occasional adjustments will be necessary when tubes and other components are changed. Also, a periodic recalibration is desirable from the standpoint of preventive maintenance.

Apparent troubles in the instrument are occasionally the result of improper calibration of one or more circuits. Consequently, calibration checks should be an integral part of any troubleshooting procedure. Abnormal indications occurring during calibration checks will often aid in isolating troubles to a definite circuit or stage. (See Table 4-1.)

In the instructions that follow, the steps are arranged in the proper sequence for a complete calibration of the instrument. Each numbered step contains the information required to make one check or adjustment or a series of related checks or adjustments. The steps are arranged to avoid unnecessary repetition of checks or adjustments.

EQUIPMENT REQUIRED

The following equipment or its equivalent is required to perform a complete recalibration of the Type 661 Oscilloscope.

1. Accurate dc voltmeter, with a sensitivity of at least 20,000 ohms per volt.
2. Nonloading dc voltmeter (such as a John Fluke 800).
3. Accurate ac voltmeter capable of reading voltages from 105 to 125 volts, rms, (from 210 to 250 volts for 234-volt instruments).
4. Ohmmeter.
5. Autotransformer with output variable between 105 and 125 (or 210 and 250) volts. Minimum rating of 1 kva.
6. Test oscilloscope with a bandpass to at least 50 mc (3 db down) and a maximum sensitivity of at least 50 millivolts per centimeter. Must also have a sensitivity of at least 5 millivolts per centimeter at reduced bandpass. Tektronix 50-mc Type 540-Series Oscilloscope and Type 1A1 Plug-In Unit or Type 580-Series Oscilloscope and Type 82 Plug-In Unit recommended.
7. Time-mark generator capable of generating crystal-controlled 500-, 100-, 50-, 10-, and 1- μ sec markers, and 5-, 10-, and 50-mc sine-waves. Tektronix Type 180A recommended.
8. Type 4S1 50 Ω Dual-Trace Sampling Unit.*
9. Type 5T1A Timing Unit.
10. A 1 k, 10%, $\frac{1}{2}$ w composition resistor.
11. A 1.5 k, 1%, $\frac{1}{2}$ w precision resistor.
12. Two 47 k, 10%, $\frac{1}{2}$ w composition resistors.
13. A 125 k, 1%, 1 w precision resistor.
14. A 2-meg, 1%, $\frac{1}{2}$ w precision resistor.
15. A 10-meg, 10 \times attenuator probe; Tektronix P6006 Probe recommended.
16. Two patch cords with banana-type connectors on each end (such as Tektronix Type PC-18R, part number 012-028), plus two slip-on alligator clips.
17. Two 42-inch 50-ohm coaxial cables with UHF or BNC plug connectors on each end (such as Tektronix part number 012-001 or 012-057).
18. An 80-inch 50-ohm coaxial cable with GR Type 874 connectors. 10-nsec signal delay. Tektronix part number 017-501.
19. A 16-inch 50-ohm coaxial cable with GR Type 874 connectors. 2-nsec delay. Tektronix part number 017-505.
20. Two clip leads fitted with a UHF or BNC jack (clip-lead adapter). Tektronix part number 013-003 or 013-076.
21. A 50-ohm midline termination fitted with UHF or BNC connectors, Tektronix part number 011-045 or 011-049. (Do not use a B-52R, part number 011-001.)
22. A 50-ohm 2 \times T attenuator. Tektronix part number 017-046 recommended.
23. Two 50-ohm 5 \times T attenuators. Tektronix part number 017-045 recommended.
24. A 50-ohm 10 \times T attenuator. Tektronix part number 017-044 recommended.
25. A General Radio Type 874-T coaxial tee connector, Tektronix part number 017-069.
26. An insulated screwdriver with a $\frac{1}{2}$ -inch plastic shank for adjusting potentiometers and capacitors. Jaco No. 125 or Tektronix part number 003-000.
27. A pocket screwdriver with an insulated shank at least 2 inches long and a blade width of approximately $\frac{3}{32}$ inch.
28. A plastic tool for adjusting large-core variable inductors, such as Walsco No. 2543 or Tektronix part number 003-301.
29. A plastic tool for adjusting small-core variable inductors, such as the combination of Tektronix part numbers 003-307 and 003-310 (see Fig. 5-9).
30. A 50- to 60-watt soldering iron.
31. (For S/N's 101-1999 only.) An insulated screwdriver with a 7-inch plastic shank for adjusting the AMPLITUDE/TIME CALIBRATOR. Jaco No. 15 or Tektronix part number 003-001.

*A Type 4S3 Sampling-Probe Dual-Trace Unit and P6038 Probes may be used instead of a Type 4S1. If a Type 4S3 is used, a VP-2 Voltage Pickoff (Tektronix part number 017-077) and an accurate 50 Ω termination with GR connector (Tektronix part number 017-047) will be required for connecting to input signals. External triggering will also be required in the procedure wherever internal triggering is specified with the Type 4S1.

Calibration—Type 661

32. Connector adapters as required for connecting between instruments and auxiliary equipment with GR, UHF and BNC-type connectors:

- GR to UHF jack, Tektronix part number 017-022.
- GR to UHF plug, Tektronix part number 017-023.
- GR to BNC jack, Tektronix part number 017-063.
- GR to BNC plug, Tektronix part number 017-064.
- BNC jack to UHF plug, Tektronix part number 103-015.
- BNC plug to UHF jack, Tektronix part number 103-032.

PRELIMINARY PROCEDURE

At the time of either a regularly scheduled recalibration, or during maintenance, make a complete visual check of the instrument.

To assist in locating troubles in the power supplies, Table 5-1 lists the minimum dc resistance to ground for each of the power supply leads. Values are given for two conditions; no plug-in units in the Type 661, and with both a Type 4S1 Dual-Trace Sampling Unit and a Type 5T1A Timing Unit in place. Be sure to observe the proper ohmmeter polarity when checking the plus and minus power supply leads.

TABLE 5-1

Power Supply Lead	Minimum Resistance No Plug-In Units	Minimum Resistance With Plug-In Units
+455	18 k	18 k
+300	6.5 k	4.5 k
+100	60 — 75 k	2 k
-100	10 k	1.2 k
-25.2	9 Ω	6.5 Ω
-19	200 — 700 Ω	8 Ω
+19	600 — 800 Ω	10 Ω

After completing the power-supply check, install both plug-in units in the Type 661. Connect the power cord and ac voltmeter to the output of the variable autotransformer. Set the INTENSITY control fully counterclockwise, turn on the instrument power, and adjust the autotransformer for an output of 117 volts (or other voltage for which the instrument is wired). Allow a warm up of several minutes before proceeding with the adjustment procedure.

ADJUSTMENT PROCEDURE

NOTE

When checking power supply voltages other than during a complete recalibration, do not change the voltage adjustments unless the supplies are out of tolerance. Since several other circuits are affected by the supply voltages, calibration of the instrument should be checked if these voltages are changed.

1. +300-Volt Power Supply

Connect the nonloading dc voltmeter (item 2 of Equipment Required) between a +300-volt test point and ground.

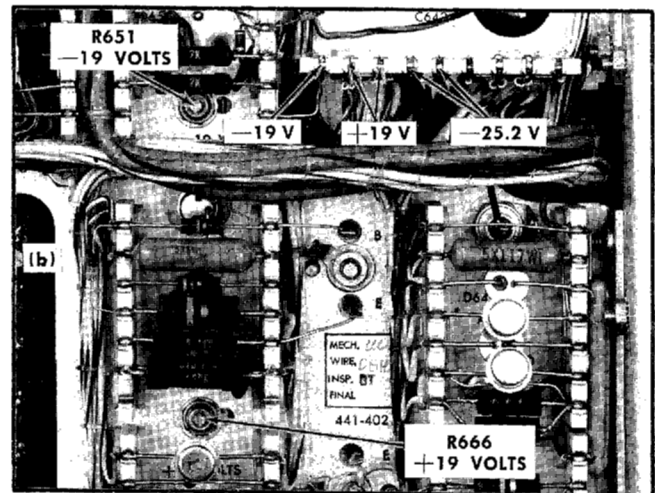
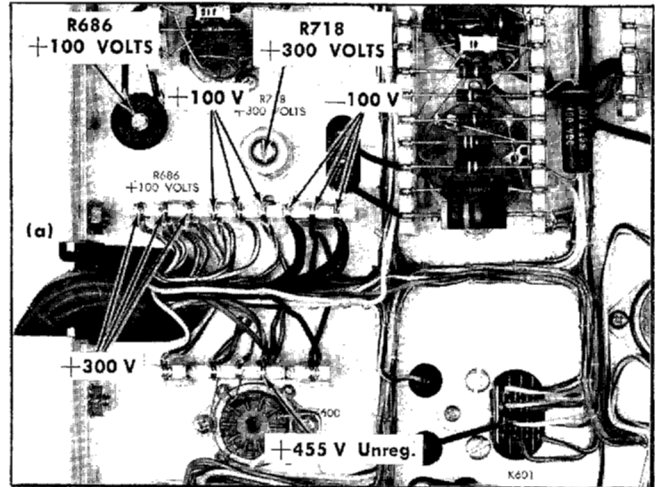

Fig. 5-1. Power supply test points. (a) Right side of oscilloscope; (b) left side of oscilloscope.

Check for a reading of +300 volts ± 2 volts and adjust R718 (+300 VOLTS) if the voltage is not within tolerance.

2. +100-Volt Power Supply

Connect the nonloading dc voltmeter between the +100-volt test point and ground. Check for a reading of +100 volts ± 1 volt and adjust R686 (+100 VOLTS).

For instruments with serial numbers below 900, the +100-volt supply is not separately adjustable. In these instrument check for a reading of +100 volts ± 3 volts.

3. -100-Volt Power Supply

Connect the nonloading dc voltmeter between the -100-volt test point and ground. The voltage should be -100 volts ± 3 volts.

4. +19-Volt Power Supply

Connect the nonloading dc voltmeter between a +19-volt test point and ground. Check for a reading of +19 volts ± 150 millivolts and adjust R666 (+19 VOLTS).

5. —25.2-Volt Power Supply

Connect the nonloading dc voltmeter between a —25.2-volt test point and ground. The voltage should be —25.2 volts ± 2 volts.

6. —19-Volt Power Supply

Connect the nonloading dc voltmeter between the —19-volt test point and ground. Check for a reading of —19 volts ± 150 millivolts and adjust R651 (—19 VOLTS).

7. Power Supply Regulation and Ripple

Use the test oscilloscope with a coax cable and clip-lead adapter (item 20 of Equipment Required) as a ripple-voltage monitor. Set the test oscilloscope sensitivity to 5 millivolts/cm. (In the event the test oscilloscope display oscillates, insert a 100 Ω , 1/2-watt resistor in series with the cable.) Make certain the Type 661 AMPLITUDE/TIME CALIBRATOR is OFF, the sweep is not running, and that the Type 4S1 MODE switch is not at DUAL TRACE.

For each power supply check listed in Table 5-2, slowly vary the output of the autotransformer from 105 volts to 125 volts (or 210 to 250 volts for 234-volt instruments). The maximum ripple should not exceed that indicated in Table 5-2.

TABLE 5-2

Power Supply	Typical Ripple 117/234-Volt Line (peak-to-peak)	Maximum Ripple (peak-to-peak)
+300	8 mv	14 mv
+100	6 mv	14 mv
—100	6 mv	14 mv
+19	4 mv	7 mv
—19	4 mv	7 mv
—25.2	15 mv	20 mv

Return the autotransformer voltage to 117 volts (or other voltage for which the instrument is wired).

DEFLECTION SENSITIVITY, S/N'S 101-309

NOTE

The following procedure for setting the deflection sensitivity is divided into two parts: steps 8 through 12 cover instruments having serial numbers from 101 through 309, and steps 13 through 17 cover instruments having serial numbers 310 and above. Be sure to read the Note concerning deflection sensitivities (under Replacement of Cathode-Ray Tube, Maintenance section) before performing steps 8 through 12.

8. Crt High-Voltage Supply

The crt supply voltage should be between —2300 and —3200 volts. This value is determined by the crt horizontal deflection factor. The voltage is adjusted to make the

horizontal system sensitivity agree with the front-panel EXT HORIZ. INPUT volts per centimeter.

Set the Type 5T1A controls:

SWEEP TIME/CM	.1 μ SEC
VARIABLE	CALIBRATED
SAMPLES/CM	100
SWEEP MODE	NORMAL (REPETITIVE)
TRIGGERING SOURCE	FREE RUN
TRIGGERING POLARITY	+
TIME POSITION (DELAY)	Clockwise (minimum)
TIME EXPANDER	$\times 1$
RECOVERY TIME	MIN.

Others controls may be in any position.

Set the Type 4S1 MODE switch to A ONLY and the Channel A controls:

VERT. POSITION	Midrange
DC OFFSET	Trace centered
MILLIVOLTS/CM	100
VARIABLE	CALIBRATED
SMOOTHING	NORMAL

Other controls may be in any position.

Set the Type 661 Oscilloscope controls:

SWEEP MAGNIFIER	$\times 1$
VOLTS/CM	DC
POSITION	Start trace at left edge of graticule.

Other controls may be in any position.

After obtaining a free-running trace, check the crt trace-to-graticule alignment. (See Note, page 2-4.)

Set the HORIZONTAL DISPLAY switch to EXT. HORIZ. INPUT, 5 VOLTS/CM. An external 50-volt signal will now move the crt spot 10 centimeters.

CAUTION

In the following procedure, be careful not to ground the +300-volt power supply.

Connect a 125 k, 1-watt, 1% resistor between a +300-volt test point (Fig. 5-1) and the EXT. INPUT 25 K Ω terminal. Measure the voltage at the EXT. INPUT terminal with the nonloading dc voltmeter to assure that the horizontal system is receiving exactly +50 volts. If the voltage is other than +50 volts, determine the percentage difference, and apply that error when making the high voltage adjustment.

Disconnect the resistor from +300 volts. Carefully position the crt spot to the left edge of the graticule. Reconnect the resistor to +300 volts. If the spot does not move exactly 10 centimeters (plus or minus the error percentage just determined), adjust R841 (HIGH VOLTAGE control, Fig. 5-2) until the spot moves the correct amount. It may be necessary to repeat this procedure several times for proper adjustment.

The preceding step will assure a horizontal accuracy of about 0.5% which applies when the HORIZONTAL DISPLAY switch is at either the SWEEP MAGNIFIER $\times 1$ or the EXT.

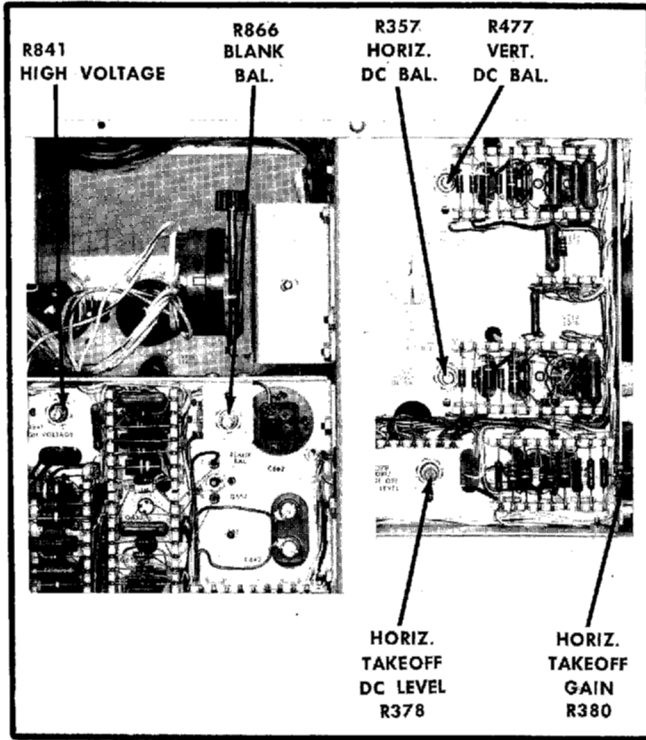

Fig. 5-2. Location of some adjustments on left side of oscilloscope (for instruments with serial numbers 101 through 309).

HORIZ. INPUT 5 VOLTS/CM positions. Due to the tolerance of the horizontal amplifier feedback resistors, the horizontal system will be less accurate in all other positions of the HORIZONTAL DISPLAY switch (see step 19).

9. Blanking Balance

Turn off the Type 661, remove both plug-in units, and turn the Type 661 back on. Set the HORIZONTAL DISPLAY switch to the $\times 1$ position of the SWEEP MAGNIFIER and reduce the intensity to the point that the spot can no longer be seen.

Connect the dc voltmeter between the center terminal of R866 (BLANK BAL control) and pin 6 of V874 to check the differential voltage between the crt blanking deflection plates. V874 is located between the two ceramic strips adjacent to the control (see Fig. 5-2). Adjust the BLANK BAL control for zero volts on the meter. Turn off the Type 661, install both plug-in units, and turn the Type 661 back on.

10. Horizontal DC Balance

Free run the timing unit at $.1 \mu\text{SEC}/\text{CM}$ and 100 SAMPLES/CM. Turn up the intensity so the trace is visible. Position the start of the trace to the center of the graticule. Set the SWEEP MAGNIFIER to $\times 100$ and reposition the trace so the first dot of the display lies under the graticule centerline. Return the SWEEP MAGNIFIER switch to $\times 1$. Adjust R357 (HORIZ. DC BAL) to return the first dot to the graticule centerline. Repeat the procedure to be sure the adjustment is correct.

11. Vertical Amplifier Sensitivity

Turn off the Type 661 and remove the Type 4S1. Turn the Type 661 back on. Reduce the crt intensity so the spot will not burn the phosphor.

After the spot is stable, adjust R477, (VERT. DC BAL) until the spot rests 3 centimeters below the graticule centerline.

Alternately connect and disconnect a 2-meg, 1% resistor between a +300-volt test point and the vertical amplifier input (see Fig. 5-3). The display should be spot alternately at -3 and $+3$ centimeters, ± 2 millimeters. If the scan is more than ± 2 millimeters from being 6 centimeters, check the vertical amplifier transistors and tubes. If they are satisfactory, then change the value of R473 according to the following procedure.

NOTE

Be sure the crt sensitivity has been properly adjusted (step 8) before changing the value of R473.

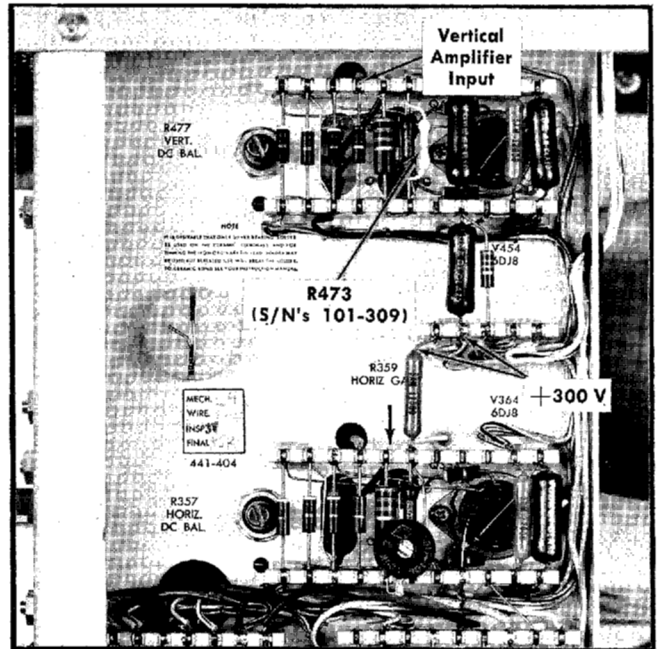

Fig. 5-3. Location of input to Type 661 Vertical Amplifier.

Procedure for Changing R473

If it is necessary to change the value of R473, remove the existing resistor (Fig. 5-3). Obtain a group of $1/4$ -watt, 1% deposited-carbon resistors ranging from about 5 through 12 megohms (such as 5, 7.5, 9, 10, and 12). Grasp a new resistor with the pliers and touch its leads to the ceramic strip terminals at the location for R473. Observe the crt display for 6 centimeters. When a resistor is found that gives the correct gain, trim its leads to the correct length and solder it in exactly the same position as the resistor removed.

Leave the Type 4S1 out of the oscilloscope for the next step.

12. Vertical DC Balance

Connect a 1.5 k, 1% resistor between the vertical amplifier input and ground.

Horizontally position the crt spot to the graticule centerline and adjust R477 (VERT. DC BAL.) to vertically position the spot to the centerline.

Remove the 1.5 k resistor, turn off the Type 661, and reinstall the Type 4S1. Turn the Type 661 back on.

Proceed to step 18.

DEFLECTION SENSITIVITY, S/N'S 310 AND ABOVE

NOTE

Steps 13 through 17 apply primarily to instruments having serial numbers 310 and above. Instruments in the serial number range from 101-309 may use this procedure if the original cathode-ray tube has been replaced by a newer tube type. Be sure to read the Note concerning deflection sensitivities (under Replacement of Cathode-Ray Tube, Maintenance section) if the crt has been replaced.

13. Crt High-Voltage Supply

The crt supply voltage should be between -2300 and -3200 volts to make the vertical amplifier sensitivity 25 μ amps/cm.

Set the Type 5T1A controls:

SWEEP TIME/CM	.1 μ SEC
VARIABLE	CALIBRATED
SAMPLES/CM	100
SWEEP MODE	NORMAL (REPETITIVE)
TRIGGERING SOURCE	FREE RUN
TRIGGERING POLARITY	+
TIME POSITION (DELAY)	Clockwise (minimum)
TIME EXPANDER	$\times 1$
RECOVERY TIME	MIN.

Other controls may be in any position.

Set the Type 4S1 MODE switch to A ONLY and the Channel A controls:

VERT. POSITION	Midrange
DC OFFSET	Trace centered
MILLIVOLTS/CM	100
VARIABLE	CALIBRATED
SMOOTHING	NORMAL

Other controls may be in any position.

After obtaining a free-running trace, check the crt trace-to-graticule alignment. (See Note, page 2-4.)

Turn off the Type 661, remove the Type 4S1, and turn the Type 661 back on. Reduce the intensity so the spot will not burn the phosphor.

After the spot is stable, adjust R477 (VERT. DC BAL.) until the spot rests 3 centimeters below the graticule centerline.

Alternately connect and disconnect a 2-meg, 1% resistor between a +300-volt test point and the vertical amplifier input (see Fig. 5-3). The display should be spot alternately at -3 and +3 centimeters, ± 2 millimeters. If the scan is more than ± 2 millimeters from being 6 centimeters, check the vertical amplifier transistors and tubes. If they are satisfactory, adjust the HIGH VOLTAGE control (R841; see Fig. 5-2) for 6 centimeters between spots as the 2-meg resistor is alternately applied and removed.

Leave the Type 661 on, without the Type 4S1, for the following step.

14. Vertical DC Balance

Connect a 1.5 k, 1% resistor between the vertical amplifier input (Fig. 5-3) and ground. Horizontally position the crt spot to the graticule centerline, and adjust R477 (VERT. DC BAL.) to vertically position the spot to the centerline.

Remove the 1.5 k resistor, turn off the Type 661, and reinstall the Type 4S1. Turn the Type 661 back on.

15. Horizontal Gain

Set the HORIZONTAL DISPLAY switch to EXT. HORIZ. INPUT, 5 VOLTS/CM, DC. An external 50-volt signal will now move the crt spot 10 centimeters.

CAUTION

In the following procedure, be careful not to ground the +300-volt power supply.

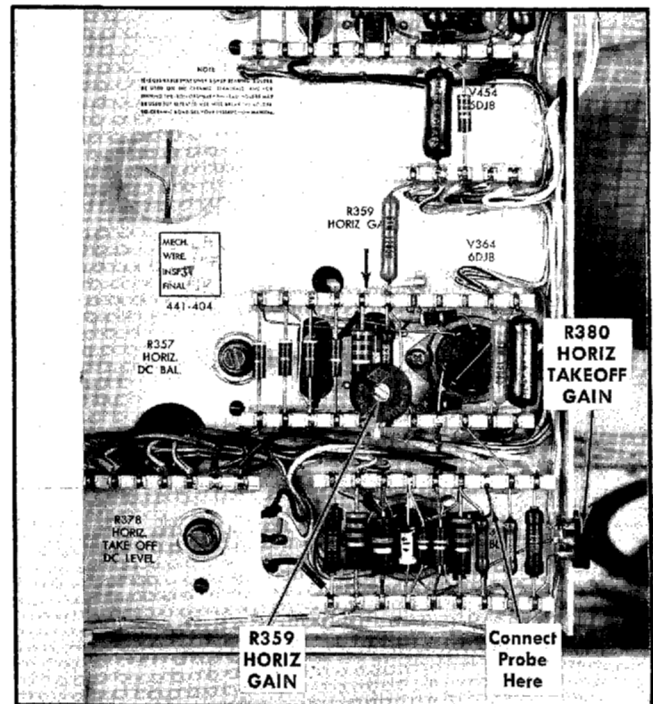

Fig. 5-4. Location of horizontal adjustments (for instruments with serial numbers 310 and above).

Calibration—Type 661

Connect a 125 k, 1-watt, 1% resistor between a +300-volt test point (Fig. 5-1) and the EXT. INPUT 25 K Ω terminal. Measure the voltage at the EXT. INPUT terminal with the nonloading dc voltmeter to assure that the horizontal system is receiving exactly +50-volts. If the voltage is other than +50 volts, determine the percentage difference, and apply that error when adjusting the HORIZ GAIN ADJ (R359; see Fig. 5-4).

Disconnect the resistor from +300 volts. Carefully position the crt spot to the left edge of the graticule. Reconnect the resistor to +300 volts. If the spot does not move exactly 10 centimeters, plus or minus the error percentage just determined, use an insulated screwdriver to adjust R359 (HORIZ GAIN ADJ; Fig. 5-4) until the spot moves the correct amount. It may be necessary to repeat this procedure several times for proper adjustment.

The preceding step will assure a horizontal accuracy of about 0.5% which applies when the HORIZONTAL DISPLAY switch is at either the SWEEP MAGNIFIER $\times 1$ or the EXT. HORIZ. INPUT 5 VOLTS/CM positions. Due to the tolerance of the horizontal amplifier feedback resistors, the horizontal system will be less accurate in all other positions of the HORIZONTAL DISPLAY switch (see step 19).

16. Blanking Balance

Turn off the Type 661, remove both plug-in units, and turn the Type 661 back on. Set the HORIZONTAL DISPLAY switch to the $\times 1$ position of the SWEEP MAGNIFIER and reduce the intensity to the point that the spot can no longer be seen.

Connect the dc voltmeter between the center terminal of R866 (BLANK BAL control) and pin 6 of V874 to check the differential voltage between the crt blanking deflection plates. V874 is located between the two ceramic strips adjacent to the control (see Fig. 5-2). Adjust the BLANK BAL control for zero volts on the meter. Turn off the Type 661, install both plug-in units, and turn the Type 661 back on.

17. Horizontal DC Balance

Set the HORIZONTAL DISPLAY switch to SWEEP MAGNIFIER $\times 1$. Free run the timing unit at .1 μ SEC/CM and 100 SAMPLES/CM. Turn up the crt intensity so the trace is visible. Position the start of the trace to the center of the graticule. Set the SWEEP MAGNIFIER to $\times 100$ and reposition the trace so the first dot of the display lies under the graticule centerline. Return the SWEEP MAGNIFIER switch to $\times 1$. Adjust R357 (HORIZ. DC BAL.) to return the first dot to the graticule centerline. Repeat the procedure to be sure the adjustment is correct.

18. Horizontal Takeoff DC Level and Gain

Free run the Timing Unit at .1 μ SEC/CM and 100 SAMPLES/CM. Adjust the Timing Unit SWEEP LENGTH control (internal) to produce a crt trace exactly 10 centimeters long. Carefully center the trace.

Connect a 10 \times probe to the test oscilloscope. Set the test-oscilloscope input for 0.5 volts/cm, dc (equals 5 volts/cm with probe). Connect the test-oscilloscope probe to the

junction of R391 (100 Ω) and the coax cable, shown in Fig. 5-4. Using an insulated screwdriver, adjust R378 (HORIZ. TAKEOFF DC LEVEL) until the beginning of the sawtooth rests at ground level.

Set the test oscilloscope input to 2 volts/cm (equals 20 volts/cm with probe). Adjust R380 (HORIZ. TAKEOFF GAIN) until the test oscilloscope display is a zero-to-50-volt sawtooth.

Restore the Timing Unit SWEEP LENGTH to 10.7 centimeters.

19. Horizontal Display

The horizontal preamplifier feedback resistors (R311A through R311J) are used in both the SWEEP MAGNIFIER and the EXT. HORIZ. INPUT positions of the HORIZONTAL DISPLAY switch. The tolerances of these resistors are checked in the following procedure with the HORIZONTAL DISPLAY switch in the EXT. HORIZ. INPUT positions, but apply as well with the switch in the SWEEP MAGNIFIER positions (see the Horiz. Amp. schematic diagram).

Set the Type 5T1A controls:

TRIGGERING SOURCE	FREE RUN
SWEEP TIME/CM	2 μ SEC

Set the Type 4S1 Controls:

MODE	A ONLY
TRIGGERING	A AC
CHANNEL A	
DISPLAY	NORMAL
MILLIVOLTS/CM	200

Leave all other controls as previously set.

Set the Type 661 HORIZONTAL DISPLAY switch to EXT. HORIZ. INPUT, 5 VOLTS/CM, DC. Connect the Time-Mark Generator through a 50-ohm cable and a 47 k, $\frac{1}{2}$ watt resistor to the Type 661 vertical amplifier input (shown in Fig. 5-3). Use item 20 of "Equipment Required" at the end of the 50-ohm cable. Set the Time-Mark Generator to deliver 50 μ sec time marks.

Externally trigger the test oscilloscope from the Time-Mark Generator trigger output terminal. Use a 1-kc trigger signal.

Connect the chassis of the test oscilloscope to the chassis of the Type 661. Connect the test oscilloscope Sawtooth Out signal to the Type 661 EXT. INPUT terminal, using a 47 k, $\frac{1}{2}$ -watt composition resistor in the signal path.

Set the test oscilloscope sweep rate to 0.5 millisecc/cm and obtain an externally triggered stable sweep. The Type 661 should now have a crt display of time marks. Adjust the test oscilloscope Variable Time/Cm control until the Type 661 display is exactly 2 time marks per centimeter beginning at the left edge of the graticule.

The procedure to check the accuracy of the other positions of the EXT. HORIZ. INPUT switch is outlined in Table 5-3. Disregard any hum or small amount of jitter during the check.

TABLE 5-3

EXT. HORIZ. INPUT	Time-Marks	Display	Tolerance
5	500 μ sec	2 per cm	0.05%
2	500 μ sec	2 per 2 1/2 cm	2%
1	100 μ sec	2 per cm	2%
.5	100 μ sec	1 per cm	2%
.2	50 μ sec	2 per 2 1/2 cm	3%
.1	10 μ sec	2 per cm	4%
.05	10 μ sec	1 per cm	6%

If any display is out of tolerance, change the horizontal preamplifier feedback resistor (R311) for the range in error.

20. Delayed Pulse 50 Ω Generator

Disconnect the time-mark signal from the vertical amplifier input. Leave the Type 4S1 controls as previously set, and set the Type 5T1A controls:

SWEEP TIME/CM	10 nSEC
VARIABLE	CALIBRATED
TIME POSITION (DELAY)	Clockwise (minimum)
TRIGGERING	
SOURCE	INT.
POLARITY	—
THRESHOLD	Near +

Leave the other Type 5T1A controls as previously set.

Set the Type 661 SWEEP MAGNIFIER to $\times 1$.

Connect a 2-nsec length of 50-ohm cable between the Type 661 DELAYED PULSE generator and the Type 4S1 Channel A input connector.

The crt display should now be a negative step display of about two centimeters amplitude. The step should occur

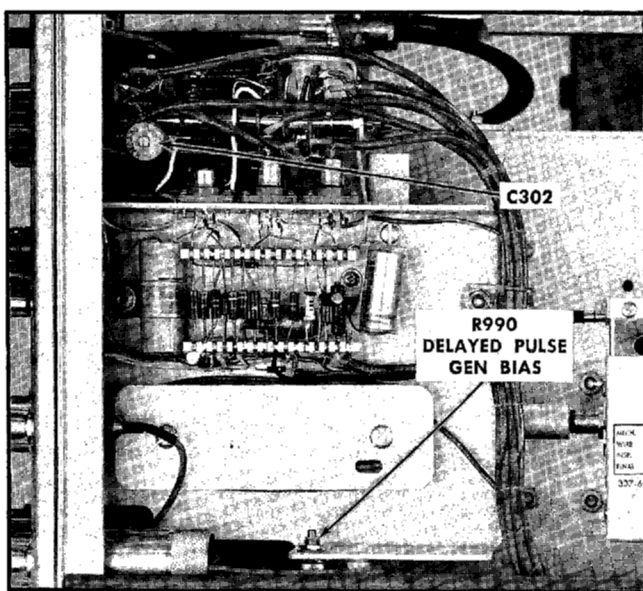

Fig. 5-5. Location of adjustments for steps 20 and 21.

between 40 and 60 nanoseconds after the start of the trace. If the step is not 40 to 60 nanoseconds after the start of the trace, or if there is no step, proceed as follows.

Locate the DELAYED PULSE GEN. BIAS control (Fig. 5-5) at the lower right side of the oscilloscope just behind the DELAYED PULSE front-panel connector. Turn it through its range. It should be possible to obtain the correct display (Fig. 2-2). If not, replace diode D992, placing its cathode (the disc side of the diode) downward so it connects to the output connector center conductor. Repeat the adjustment of the DELAYED PULSE GEN. BIAS control to obtain a proper display.

Slowly withdraw the cable connector until the center conductor is barely disconnected. The display should show approximately one-half to one centimeter of capacitively-coupled signal. If no signal appears or if the display is not stable, the Delayed Pulse generator is free running. Readjust R990 until both the Delayed Pulse display and the capacitively-coupled display remain stable as the cable is alternately connected and disconnected.

21. Horizontal Amplifier Input Compensation

Leave the system connected as in the preceding step and change the Type 5T1A SAMPLES/CM switch to 5.

Using an insulated screwdriver, adjust C302 (located on the side of the HORIZONTAL DISPLAY switch) for minimum tail at the left of each dot. Return the Type 5T1A SAMPLES/CM switch to 100.

AMPLITUDE/TIME CALIBRATOR, S/N'S 101-1999

NOTE

The following procedure for adjusting controls in the Amplitude/Time Calibrator circuit is divided into two parts: steps 22 and 23 cover instruments having serial numbers from 101-1999, and steps 24 through 26 cover instruments having serial numbers 2000 and above.

22. Amplitude (Preliminary)

Set the mV AMPLITUDE switch to 1000, and the μ SEC/CYCLE switch to 1.

Set R959 (AMPL. LIMIT, located on top of the Calibrator chassis; see Fig. 5-6a) fully counterclockwise.

Calibrate the test oscilloscope to be accurate at 1 volt/2 cm.

Connect the 50-ohm midline termination to the input of the test oscilloscope.

Connect the AMPLITUDE/TIME CALIBRATOR output to the 50-ohm termination on the test oscilloscope. Use the 10-nsec cable and the appropriate connector adapter.

Set the Type 661 on its left side and adjust R909 (1 MC CAL. AMPL.) to produce exactly 1 volt of deflection on the test oscilloscope.

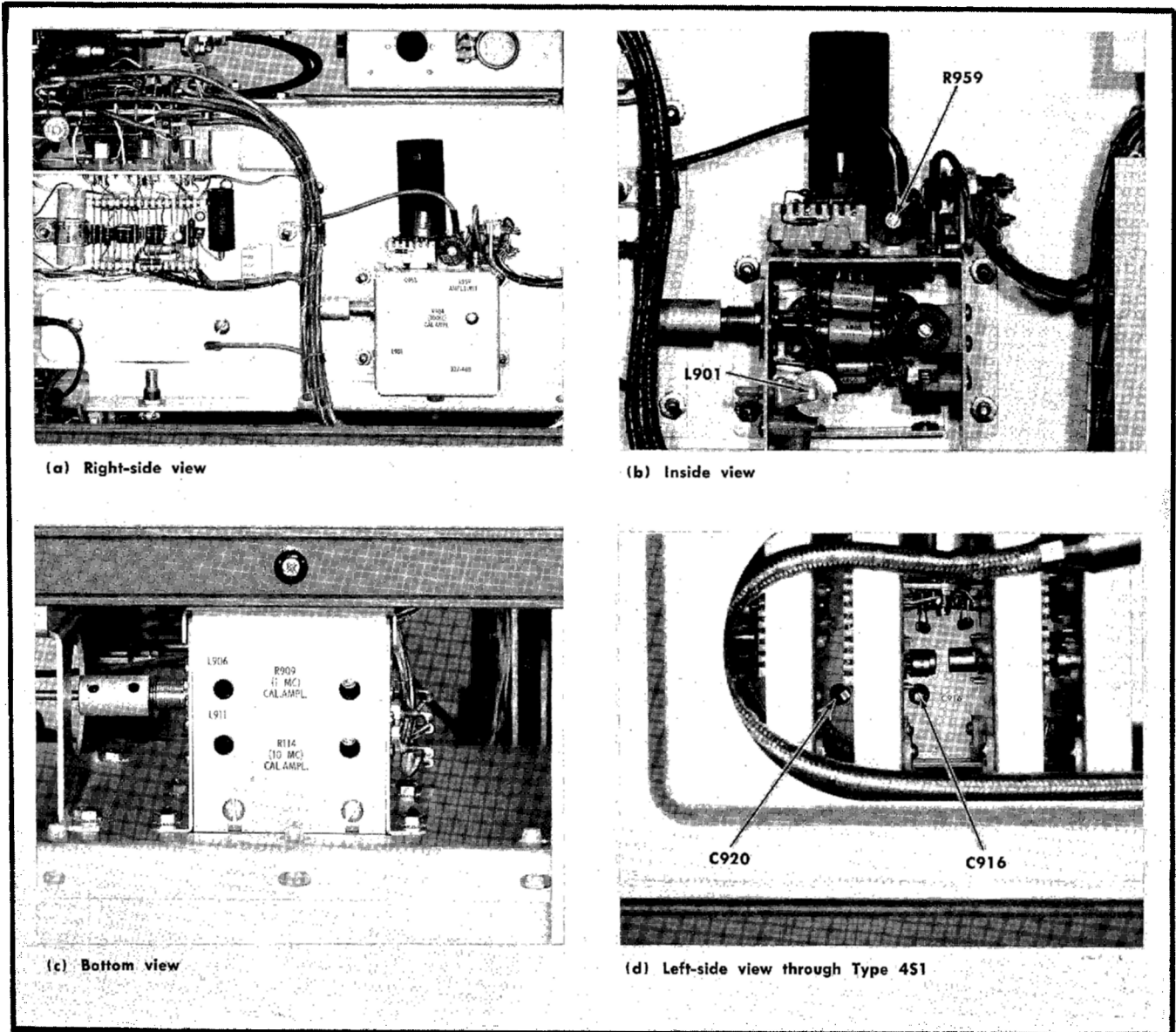

Fig. 5-6. Location of Amplitude/Time Calibrator adjustments (for instruments with serial numbers 101 through 1999), steps 22 and 23.

23. Frequency and Amplitude

Disconnect the signal cable from the 50-ohm termination and connect it to the Type 4S1 Channel B input. Set the Channel B MILLIVOLTS/CM control to 200, CALIBRATED. Set the Type 5T1A SWEEP TIME/CM control to 1 μ SEC, the TRIGGERING POLARITY switch to CAL., and the THRESHOLD control near —. If necessary, adjust the B CAL. control (top rear of Type 4S1) for a display of exactly 5 centimeters peak-to-peak. The Type 4S1 Channel B is now calibrated accurately for 200 mv/cm. (If you adjusted the B CAL. control, repeat with Channel A and adjust the front-panel A-B BAL. control.)

Connect the Time-Mark Generator to the Type 4S1 Channel A input through a 50 Ω cable and a 50 Ω 5XT Attenuator.

Apply a 10-mc sine wave to Channel A. Connect the AMPLITUDE/TIME CALIBRATOR output to Channel B input

and set the MODE switch to A ONLY. Set the TRIGGERING switch to A.

Set the Type 5T1A TRIGGERING POLARITY switch to +, the SOURCE switch to INT., the SWEEP TIME/CM switch to .1 μ SEC, and the THRESHOLD control near + for a stable display. Note the timing accuracy of the 10-mc waveform. There should be 1 cycle per centimeter. If the display is other than 1 cycle per centimeter, adjust R267 (Type 5T1A SWEEP CAL. control) to correct the error.

Set the AMPLITUDE/TIME CALIBRATOR μ SEC/CYCLE switch to .1.

Set the Type 4S1 MODE switch to B ONLY, the Type 5T1A TRIGGERING POLARITY switch to CAL., and the THRESHOLD control near — for a stable display.

Adjust L911 with a plastic adjusting tool until the display is exactly 1 cycle per centimeter (see Figs. 5-6c and 5-7).

Adjust R914, the 10 MC CAL. AMPL. control, for a display height of 5.2 centimeters. R914 has two possible positions for this amplitude. Use the position nearest the counterclockwise end of rotation.

Adjust R959 (AMPL. LIMIT) for exactly 5 centimeters of display. R959 is now adjusted in its permanent position. The 10-mc display will look like Fig. 5-7 when the adjustment is set correctly.

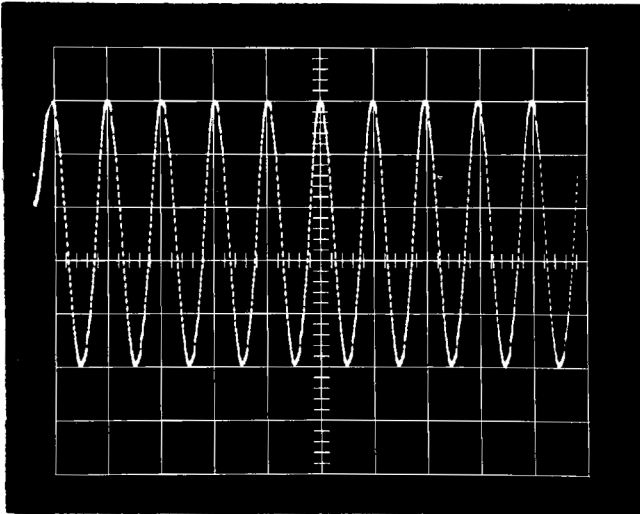

Fig. 5-7. Typical Calibrator signal for step 23 (for instruments with serial numbers 101 through 1999).

Follow the same procedure for adjusting the other AMPLITUDE/TIME CALIBRATOR ranges. Table 5-4 lists the proper controls, control settings, and displays for all ranges of the AMPLITUDE/TIME CALIBRATOR. Use the screwdriver listed as item 31, Equipment Required.

Proceed to step 27.

TABLE 5-4
AMPLITUDE/TIME CALIBRATOR Adjustments
S/N's 101-1999

Begin with R959 fully counterclockwise.				
Cal. Range	Time-Mark Signal	Type 5T1A TIME/CM	Display	Adjust
	10 mc	.1 μSEC	1 cycle/cm	Reference
.1			1 cycle/cm 5.2 cm 5.0 cm	L911 R914 R959
	10 μsec	10 μSEC	1 cycle/cm	Reference
10			1 cycle/cm 5.0 cm	L901* R904
	1 μsec	1 μSEC	1 cycle/cm	Reference
1			1 cycle/cm 5.0 cm	L906 R909
	50 mc	10 nSEC	1 cycle/2 cm	Reference
.01			1 cycle/cm 5.0 cm	C916 C920

*L901 can be adjusted by removing the oscillator shield and changing the position of the rear ferrite core in relation to the front cup core by hand. Place the shield back in place when checking the crt display for 1 cycle/cm.

AMPLITUDE/TIME CALIBRATOR, S/N'S 2000 AND ABOVE

NOTE

Steps 24 through 26 apply only to instruments having serial numbers 2000 and above.

24. Waveshape and Timing (Preliminary)

Due to interaction between the timing and amplitude controls, a preliminary timing check is made before adjusting the output amplitude.

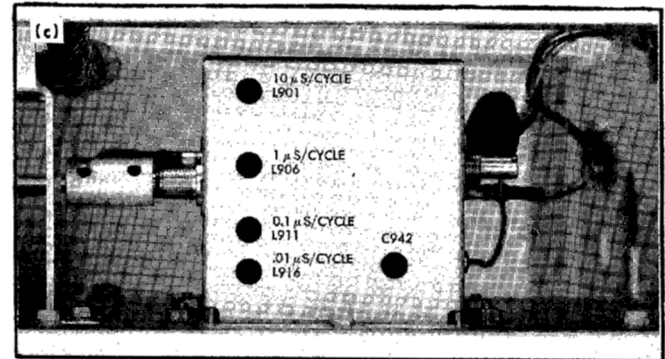
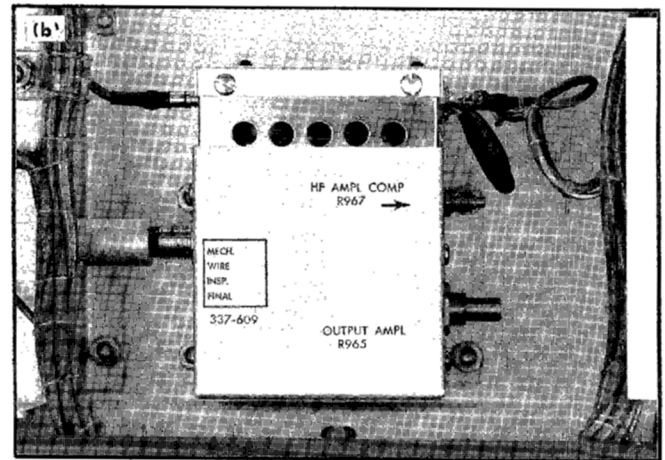
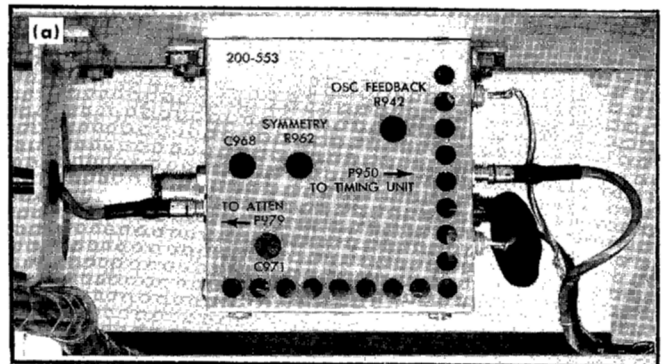

Fig. 5-8. Location of Amplitude/Time Calibrator adjustments (for instruments with serial numbers 2000 and above), steps 24 through 26. (a) Top view; (b) side view; (c) bottom view. Leave covers on the Calibrator chassis and insert adjustment tools through the holes in the covers.

Calibration—Type 661

Set the Type 5T1A controls:

SWEEP TIME/CM	0.1 μ SEC
TRIGGERING SOURCE	INT.
TRIGGERING POLARITY	+
SAMPLES/CM	100
TIME POSITION (DELAY)	Clockwise (minimum)
RECOVERY TIME	MIN.
THRESHOLD	Near —

Set the Type 4S1 controls:

MILLIVOLTS/CM	200
MODE	A ONLY
SMOOTHING	NORMAL

Leave all other controls as previously set.

Connect the Time-Mark Generator to the Type 4S1 Channel A input through a 50-ohm cable, an adapter and a 50-ohm 5 \times T attenuator. Set the generator for a 10-mc sine-wave output and trigger the display with the Type 5T1A THRESHOLD control. There should be one cycle per centimeter. If the display is other than 1 cycle/cm, adjust the Type 5T1A SWEEP CAL control (internal) to correct the error.

Disconnect the Time-Mark Generator from the Type 4S1 input. Set the Type 661 μ SEC/CYCLE to .1 and the mV AMPLITUDE switch to 1000. Set the Type 5T1A SWEEP TIME/CM switch to 20 nSEC and the TRIGGERING POLARITY to CAL.

Lay the Type 661 on its left side. Connect a 2-nsec 50-ohm cable from the AMPLITUDE/TIME CALIBRATOR output to the Type 4S1 Channel A input. Trigger the display with the Type 5T1A THRESHOLD control. If there is no display, adjust R942 to start operation of the calibrator oscillator.

Adjust the Amplitude/Time Calibrator controls listed in Table 5-5 to obtain the displays as indicated. Perform the adjustments in the sequence given, starting at the top of the table. Locations of the controls are shown in Fig. 5-8. Precise timing adjustments will be made later in the calibration procedure.

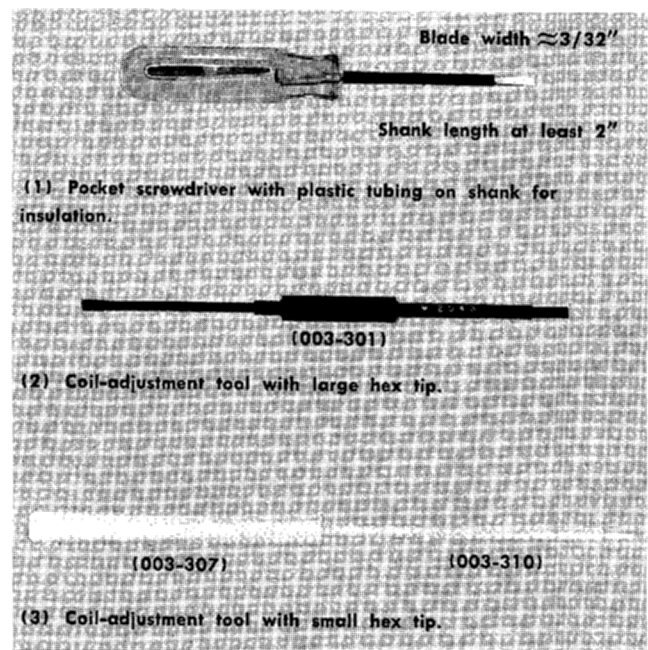

Fig. 5-9. Adjustment tools for setting controls in Amplitude/Time Calibrator circuit (for instruments with serial numbers 2000 and above). Six-digit numbers are Tektronix part numbers.

TABLE 5-5

Preliminary Calibrator Adjustments
(S/N's 2000 and above)

μ SEC/ CYCLE	Type 5T1A TIME/CM	Check for	Adjust	Tool (see Fig. 5-9)
.1	20 nSEC	Level top and bottom on waveform	C971	(1)
		Minimum waveform distortion	R942 (OSC FEEDBACK)	(1)
		Symmetry	R962 (SYMMETRY)	(1)
.01	10 nSEC	Approx. 1 cycle/cm	L916	(2)
.1	.1 μ SEC	Approx. 1 cycle/cm	L911	(3)
1	1 μ SEC	Approx. 1 cycle/cm	L906	(3)
10	10 μ SEC	Approx. 1 cycle/cm	L901	(1)
.01	2 nSEC	Squarest possible corners	C942	(1)
		Waveshape similar to Fig. 5-10.*	C968 (Set mV AMPLITUDE to 100 and MV/CM to 20 for this adjustment.)	(1)

*If a Type 4S3 Sampling Unit is used for Calibrator adjustments, set C968 for a level top and bottom on the waveform.

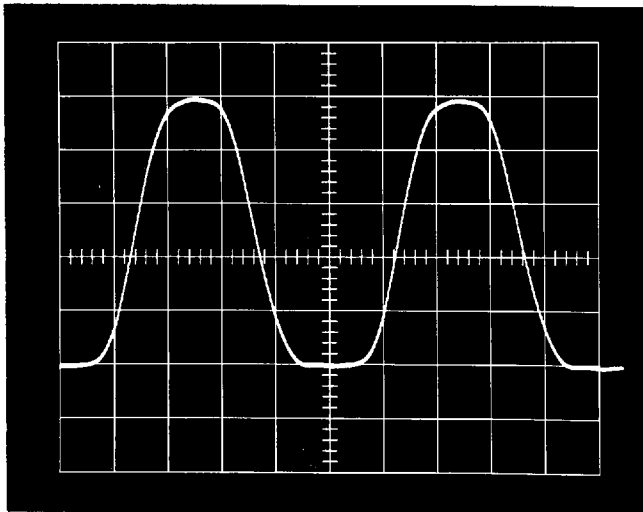

Fig. 5-10. Appearance of .01 μ SEC/CYCLE display with a Type 4S1 vertical plug-in unit when C968 is adjusted correctly. Waveform is flat on the bottom when C968 is adjusted with a Type 4S3 plug-in unit.

25. Amplitude

Leave the calibrator output connected to the Type 4S1 input. Set the mV AMPLITUDE switch to 1000 and the Type 4S1 MILLIVOLTS/CM switch to 200. With the μ SEC/CYCLE switch set at .01, trigger the display and set the positive peak of the waveform at the horizontal centerline. Connect the non-loading voltmeter to the OFFSET MONITOR jack on the Type 4S1 and note the voltage at the jack. This voltage is 100 times the voltage offset of the waveform peak. Turn the DC OFFSET control to position the negative peak of the calibrator waveform at the horizontal centerline. Measure the voltage at the OFFSET MONITOR jack and determine the difference from the first reading. This difference is 100 times the peak-to-peak amplitude of the calibrator signal (see Table 5-6). Due to signal losses and compensation at the input of the Type 4S1 system, the calibrator output measures about 2% less than its actual amplitude. Adjust R965 if the amplitude is not correct as measured at the OFFSET MONITOR jack.

TABLE 5-6

Calibrator Amplitude Adjustments
(S/N's 2000 and above)

μ SEC/ CYCLE	Type 5T1A SWEEP TIME/CM	Amplitude (Measured with DC OFFSET)		Adjust
		Type 4S1	Type 4S3*	
.01	5 nSEC	980 \pm 80 mv	1000 \pm 80 mv	R965
.1	50 nSEC	990 \pm 20 mv	1000 \pm 20 mv	R967
1	.5 μ SEC	1000 \pm 20 mv	1000 \pm 20 mv	—
10	5 μ SEC	1000 \pm 20 mv	1000 \pm 20 mv	—

*Used with P6038 Probe and VP-2 with 50-ohm termination at OUTPUT INTO 50 Ω connector.

After adjusting R965 with the μ SEC/CYCLE switch at .01, set the switch to the .1 position and adjust R967 (see Table 5-6). Also check that the 1000 mv amplitude is within tolerance at the 1 μ SEC and 10 μ SEC positions.

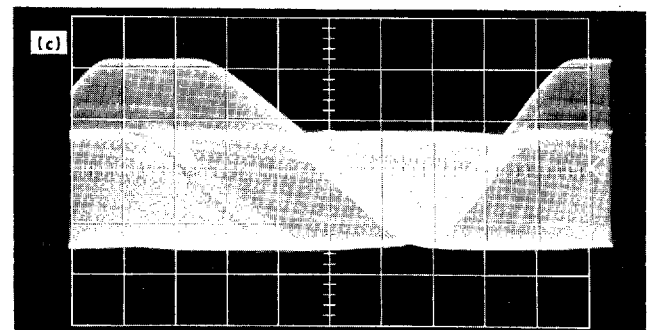
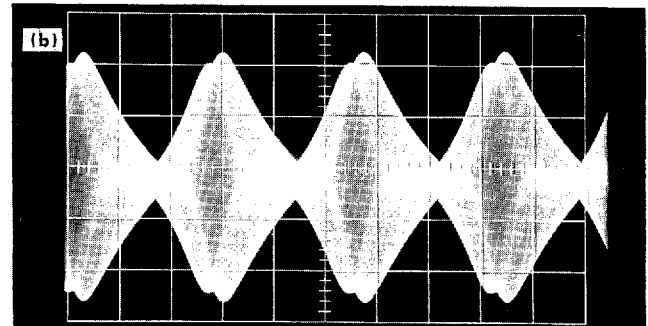
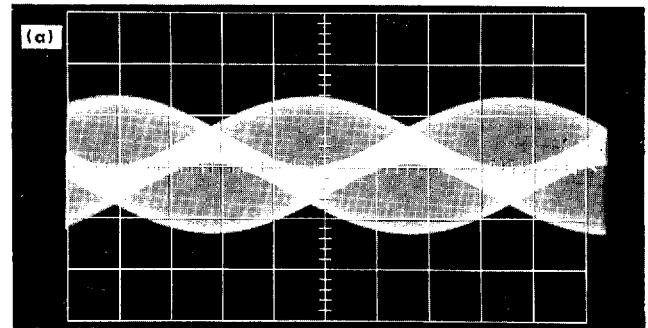

Fig. 5-11. Typical test oscilloscope displays with timing adjustments set near the beat frequencies: (a) L916 adjusted near the harmonic frequency; (b) L911 set on either side of the beat-frequency null point; (c) L906 or L901 set near the null point.

Set the Type 4S1 MILLIVOLTS/CM switch to 200, the Type 5T1A SWEEP TIME/CM to 50 nSEC, the mV AMPLITUDE to 1000 and the μ SEC/CYCLE switch to .1. Trigger the display and adjust the Type 4S1 front-panel A-B BAL control for a display amplitude of 5 cm. Set the MODE switch to B ONLY and move the calibrator signal to the Channel B input. Adjust the B CAL control on the Dual-Trace subchassis of the Type 4S1 for the correct display amplitude (5 cm).

Return the MODE switch to A ONLY and the calibrator signal to the Channel A input. Check the output attenuator by displaying the various μ SEC/CYCLE signals at each of the four steps of the mV AMPLITUDE switch. Tolerance relative to the amplitude at 1000 mv is given in Table 5-7.

TABLE 5-7
mV AMPLITUDE Tolerance

μ SEC/ CYCLE	Tolerance at mV AMPLITUDE Positions			
	1 mV	10 mV	100 mV	1000 mV
.01	$\pm .11$ mv*	± 1 mv*	± 9 mv	± 80 mv
.1	$\pm .06$ mv	$\pm .5$ mv	± 4 mv	± 20 mv
1	$\pm .06$ mv	$\pm .5$ mv	± 4 mv	± 20 mv
10	$\pm .06$ mv	$\pm .5$ mv	± 4 mv	± 20 mv

*NOTE: Ringing may be observed at these positions.

26. Timing

Accurate timing adjustment of each output frequency from the AMPLITUDE/TIME CALIBRATOR is made by mixing the output signal with a time-mark signal and adjusting for the beat-frequency null point. (For the .01 position of the μ SEC/CYCLE switch, the adjustment is made for the beat-frequency harmonic point.) Be sure the oscilloscope and Time-Mark Generator are thoroughly warmed up before making these adjustments.

Connect a 10 \times T attenuator to the marker output of the Type 180A Time-Mark Generator. Install a 50-ohm 5 \times T attenuator on the calibrator output connector and a 50-ohm GR tee connector on the attenuator. Install a 50-ohm mid-line termination on the input of the test oscilloscope. Connect 50-ohm cables from the tee connector to the termination on the test oscilloscope input, using adapters as necessary. Set the mV AMPLITUDE switch to 1000 and set the test oscilloscope input deflection factor to .05 volts.

Adjust the frequency controls as indicated in Table 5-8. If the beat frequency is within the limit indicated, no adjustment is required. The display for adjusting the .01 μ sec/cycle control will be similar to Fig. 5-11a on each side of the beat harmonic point. The appearance of the display will depend somewhat on the bandpass of the test oscilloscope and on the relative amplitudes of the time-mark and calibrator signals. Leave the 5 \times attenuator on the OUTPUT INTO 50 Ω connector for all of the timing adjustments and leave the mV AMPLITUDE switch to 1000. For each timing adjustment, use attenuation as needed on the Time-Mark Generator output so the timing signal to the test oscilloscope will produce approximately the same display amplitude as the signal from the Amplitude/Time Calibrator. Adjust the test oscilloscope input deflection factor as required to display an amplitude of 2 cm or more. Trigger the test oscilloscope internally on the beat frequency. If no beat signal appears at the indicated sweep rate, set the test oscilloscope for a very fast sweep and observe the waveform. If the composite waveform is stable, the frequency coincidence is nearly perfect and requires no adjustment.

Due to a slight frequency drift in the Time-Mark Generator and the Amplitude/Time Calibrator, the beat frequency will not remain absolutely stable. If the adjustments are made as indicated, however, the calibrator timing will be adjusted to within 0.01% of the Time-Mark Generator output frequency.

27. Signal Outputs

Continue to display the AMPLITUDE/TIME CALIBRATOR signal; any frequency will be convenient. Set the display to be exactly 5 centimeters peak-to-peak.

Measure the output signal at each SIGNAL OUTPUTS terminal with the test oscilloscope. Each signal should be 200 mv for each centimeter of crt display, $\pm 3\%$.

TABLE 5-8
Calibrator Frequency Adjustments
(S/N's 2000 and above)

μ SEC/ CYCLE	Time-Mark Signal	Approx. Time-Mark Atten.	Test Sweep Rate	Max. Beat Cycle per Display	Adjust	Tool (Fig. 5-9)
.01	50 mc	50 \times	50 μ sec/cm	10	L916	(5)
.1	10 mc	20 \times	.5 msec/cm	10	L911	(4)
1	1 μ sec	5 \times	.5 msec/cm	1	L906	(4)
10	10 μ sec	2 \times	5 msec/cm	1	L901	(1)

SECTION 6

PARTS LIST AND SCHEMATICS

PARTS ORDERING INFORMATION

Replacement parts are available from or through your local Tektronix Field Office.

Changes to Tektronix instruments are sometimes made to accommodate improved components as they become available, and to give you the benefit of the latest circuit improvements developed in our engineering department. It is therefore important, when ordering parts, to include the following information in your order: Part number including any suffix, instrument type, serial number, and modification number if applicable.

If a part you have ordered has been replaced with a new or improved part, your local Tektronix Field Office will contact you concerning any change in part number.

ABBREVIATIONS AND SYMBOLS

a or amp	amperes	mm	millimeter
BHS	binding head steel	meg or M	megohms or mega (10 ⁶)
C	carbon	met.	metal
cer	ceramic	μ	micro, or 10 ⁻⁶
cm	centimeter	n	nano, or 10 ⁻⁹
comp	composition	Ω	ohm
cps	cycles per second	OD	outside diameter
crt	cathode-ray tube	OHS	oval head steel
CSK	counter sunk	p	pico, or 10 ⁻¹²
dia	diameter	PHS	pan head steel
div	division	piv	peak inverse voltage
EMC	electrolytic, metal cased	plstc	plastic
EMT	electrolytic, metal tubular	PMC	paper, metal cased
ext	external	poly	polystyrene
f	farad	Prec	precision
F & I	focus and intensity	PT	paper tubular
FHS	flat head steel	PTM	paper or plastic, tubular, molded
Fil HS	fillister head steel	RHS	round head steel
g or G	giga, or 10 ⁹	rms	root mean square
Ge	germanium	sec	second
GMV	guaranteed minimum value	Si	silicon
h	henry	S/N	serial number
hex	hexagonal	t or T	tera, or 10 ¹²
HHS	hex head steel	TD	toroid
HSS	hex socket steel	THS	truss head steel
HV	high voltage	tub.	tubular
ID	inside diameter	v or V	volt
incd	incandescent	Var	variable
int	internal	w	watt
k or K	kilohms or kilo (10 ³)	w/	with
kc	kilocycle	w/o	without
m	milli, or 10 ⁻³	WW	wire-wound
mc	megacycle		

SPECIAL NOTES AND SYMBOLS

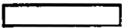
X000	Part first added at this serial number.
000X	Part removed after this serial number.
*000-000	Asterisk preceding Tektronix Part Number indicates manufactured by or for Tektronix, or reworked or checked components.
Use 000-000	Part number indicated is direct replacement.
	Internal screwdriver adjustment.
	Front-panel adjustment or connector.

**MECHANICAL PARTS
PARTS LOCATOR**

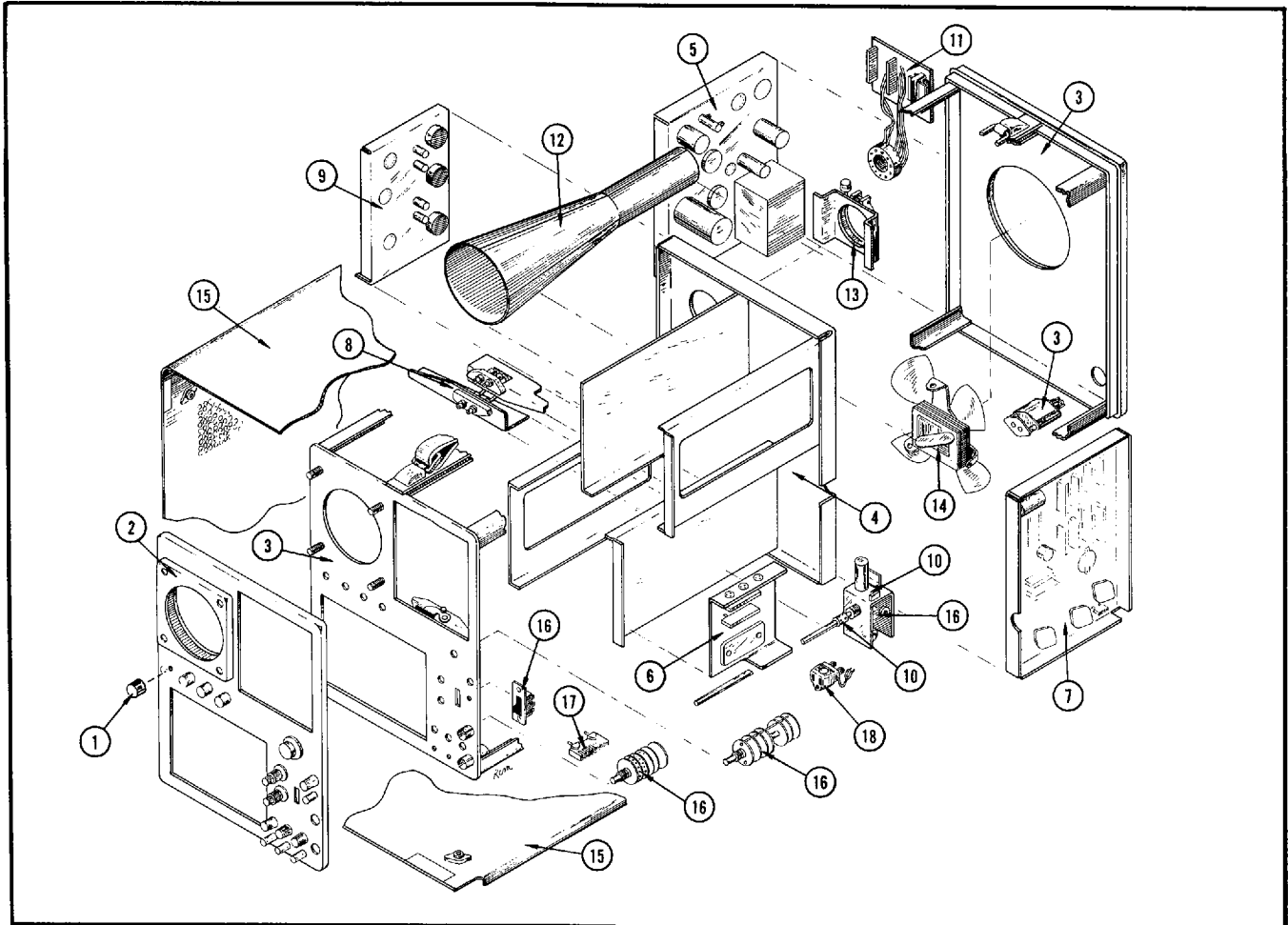

REF. NO.	PART NO.	SERIAL NO.		QTY.	DESCRIPTION
		EFF.	DISC.		
1.	Pg. 6-3				KNOBS
2.	Pg. 6-4				FRONT
3.	Pg. 6-5				FRAME GROUP
4.	Pg. 6-8				SUPPORT GROUP
5.	Pg. 6-10				TRANSISTOR POWER CHASSIS
6.	Pg. 6-13				HORIZONTAL PREAMPLIFIER CHASSIS
7.	Pg. 6-14				TUBE POWER CHASSIS
8.	Pg. 6-17				50-OHM PLUG-IN CONNECTING BRACKETS
9.	Pg. 6-18				VERTICAL AMPLIFIER CHASSIS
10.	Pg. 6-20				CALIBRATOR CHASSIS
11.	Pg. 6-22				FOCUS AND INTENSITY
12.	Pg. 6-24				CRT SHIELD
13.	Pg. 6-25				CRT BRACKET AND ROTATOR
14.	Pg. 6-26				FAN
15.	Pg. 6-27				CABINET
16.	Pg. 6-28				SWITCHES
17.	Pg. 6-30				CERAMIC STRIPS
18.	Pg. 6-31				ACCESSORIES

KNOBS

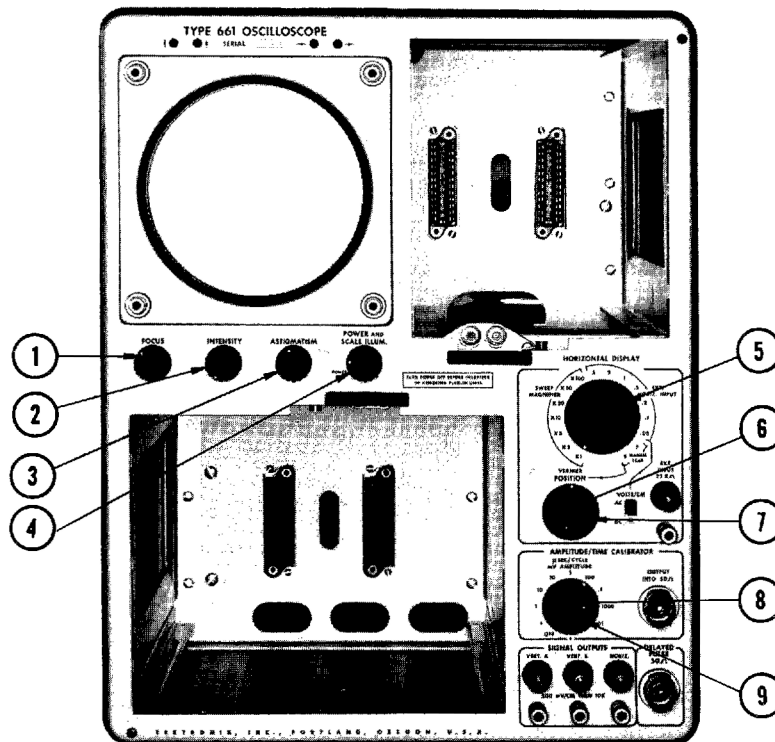

REF. NO.	PART NO.	SERIAL NO.		QTY.	DESCRIPTION
		EFF.	DISC.		
1.	366-113			1	KNOB, FOCUS, charcoal Includes: SCREW, set, 6-32 x 3/16 in. HHS
	213-004			1	
2.	366-113			1	KNOB, INTENSITY, charcoal Includes: SCREW, set, 6-32 x 3/16 in. HHS
	213-004			1	
3.	366-113			1	KNOB, ASTIGMATISM, charcoal Includes: SCREW, set, 6-32 x 3/16 in. HHS
	213-004			1	
4.	366-113			1	KNOB, POWER AND SCALE ILLUM., charcoal Includes: SCREW, set, 6-32 x 3/16 in. HHS
	213-004			1	
5.	366-115			1	KNOB, HORIZONTAL DISPLAY, charcoal Includes: SCREW, set, 6-32 x 3/16 in. HHS
	213-004			1	
6.	366-032			1	KNOB, VERNIER, red Includes: SCREW, set, 6-32 x 3/16 in. HHS
	213-004			1	
7.	366-146			1	KNOB, POSITION, charcoal Includes: SCREW, set, 6-32 x 3/16 in. HHS
	213-004			1	
8.	366-031			1	KNOB, μSEC/CYCLE, red Includes: SCREW, set, 6-32 x 3/16 in. HHS
	213-004			1	
9.	366-142			1	KNOB, mV AMPLITUDE, charcoal Includes: SCREW, set, 6-32 x 3/16 in. HHS
	213-004			1	

FRONT

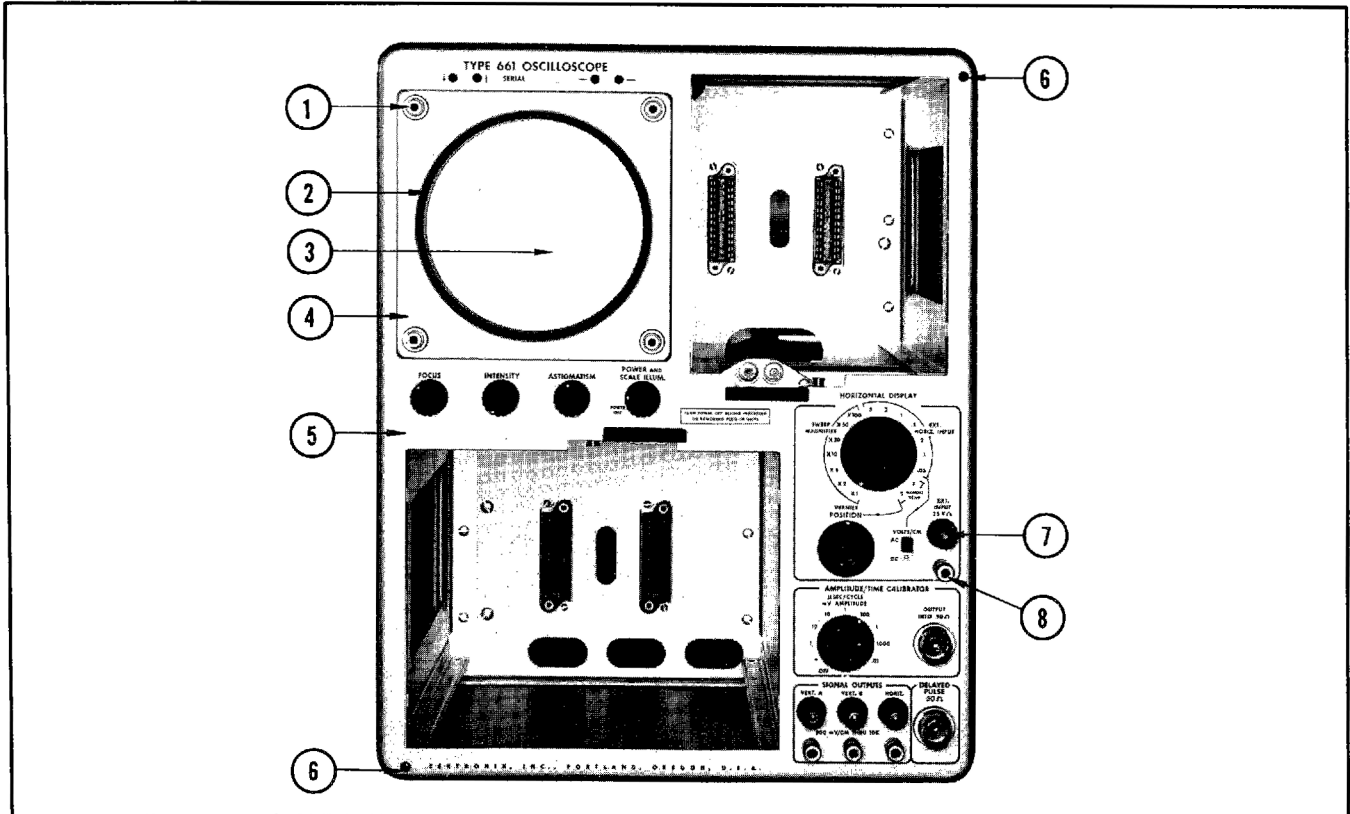

REF. NO.	PART NO.	SERIAL NO.		QTY.	DESCRIPTION
		EFF.	DISC.		
1.	210-816			4	WASHER, rubber
	210-424			4	NUT, knurled brass, 3/8-24 x 9/16 x 3/16 in.
2.	337-187			1	SHIELD, 5 in. graticule light (under cover)
3.	331-056			1	GRATICULE, 5 in.
4.	200-382			1	COVER, graticule
5.	333-684			1	PANEL, front
6.	213-035			2	SCREW, thread cutting, 4-40 x 1/4 in. PHS, phillips
7.	129-063			4	POST, binding, 5 way, charcoal grey
	210-206			4	LUG, solder, SE10 long
	210-445			8	NUT, hex, steel, 10-32 x 3/8 x 1/8 in.
8.	358-169			4	BUSHING, binding post, charcoal
	129-051			4	POST, binding assembly Consisting of:
	200-182			1	CAP, binding post
	210-011			1	LOCKWASHER, steel, internal 1/4 in.
	210-455			1	NUT, hex, steel, 1/4-28 x 3/8 x 3/32 in.
	355-507			1	STEM, binding post adapter
	210-223			3	LUG, solder, 1/4 in. hole

FRAME GROUP

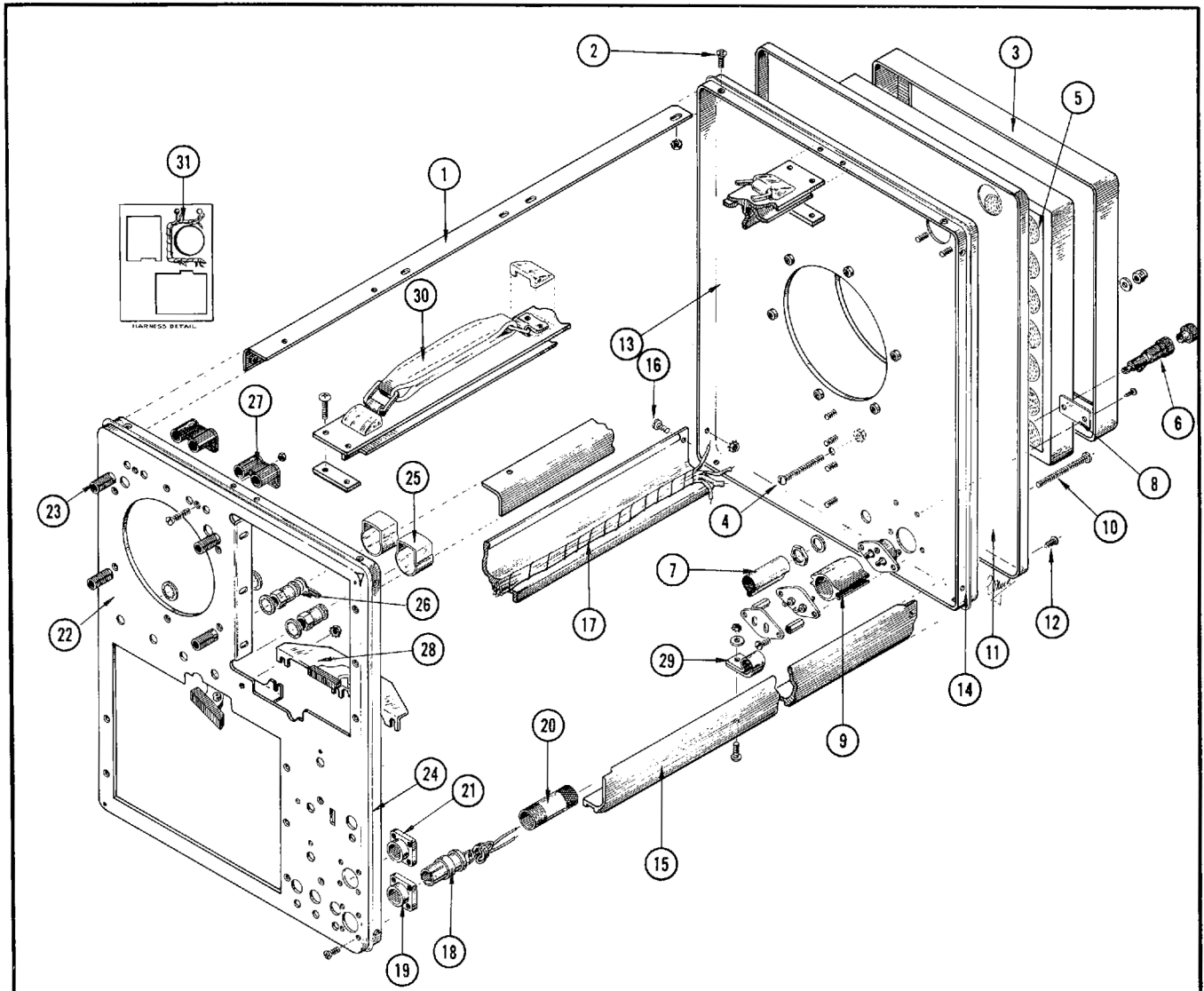

REF. NO.	PART NO.	SERIAL NO.		QTY.	DESCRIPTION
		EFF.	DISC.		
1.	122-100			2	ANGLE, frame, top, alum. ext. 20 ⁷ / ₁₆ in. long Mounting Hardware: (not included)
2.	211-559			8	SCREW, 6-32 x ³ / ₈ in. 100° CSK, phillips, FHS
	210-457			8	NUT, keps, steel, 6-32 x ⁵ / ₁₆ in.
3.	380-018			1	HOUSING, air filter, alum. 10 ¹ / ₂ x 10 ¹ / ₂ x 1 in. blue vinyl Mounting Hardware: (not included)
4.	212-031			2	SCREW, 8-32 x 1 ¹ / ₄ in. RHS
	210-458			2	NUT, keps, steel, 8-32 x 1 ¹ / ₃₂ in.
	210-402			2	NUT, cap, hex, brass, 8-32 x ⁵ / ₁₆ in.
5.	378-011			1	FILTER, air, alum. 10 x 10 x 1 in.
6.	352-002			1	HOLDER, fuse assembly Consisting of:
	200-015			1	CAP, fuse, 3AG
	210-873			1	WASHER, rubber, ¹ / ₂ ID x 1 ¹ / ₁₆ OD x ³ / ₆₄ in.
	352-010			1	HOLDER, fuse, 3AG

FRAME GROUP (continued)

REF. NO.	PART NO.	SERIAL NO.		QTY.	DESCRIPTION
		EFF.	DISC.		
	No Number				NUT, fuse holder
7.	200-237			1	COVER, insulation fuse holder, clear polyethylene (not incl.)
8.	334-649			1	TAG, voltage rating Mounting Hardware: (not included)
	213-035			2	SCREW, thread forming, 4-40 x 1/4 in. PHS, phillips
9.			1	FILTER, AC line Consisting of:
	131-102			1	CONNECTOR, chassis mount, 3 wire Tek motor base
	387-025			2	PLATE, alum. 1 3/64 x 1 1/4 in.
	385-146			2	ROD, hex, alum. 1/4 x 1 1/16 in.
	211-504			2	SCREW, 6-32 x 1/4 in. BHS
10.	211-552			2	SCREW, 6-32 x 2 in. BHS
11.	387-480			1	PLATE, rear overlay, alum. 15.879 x 12.629 x .280 in. Mounting Hardware: (not included)
12.	213-104			4	SCREW, thread forming #6 x 3/8 in. truss H steel, phillips
13.	387-475			1	PLATE, subpanel, rear, alum. 15 1/16 x 12 7/16 x 1 5/16 in. Includes:
14.	354-056			1	RING, ornamental, stainless steel, 1/8 x 12 5/8 x 15 7/8 in.
15.	122-099			2	ANGLE, frame bottom, alum. ext. 20 7/16 in. long Mounting Hardware: (not included)
16.	212-039			4	SCREW, 8-32 x 3/8 in. THS, phillips
	210-458			4	NUT, keps, steel, 8-32 x 1 1/32 in.
17.	179-586			1	CABLE harness, 110 V
18.			1	PULSE GENERATOR Consisting of:
	344-074			2	CLIP, grounding, berylco, .468 x .085 in.
	344-073			1	CLIP, center, conductor, berylco, 1/4 in. dia.
	352-040			1	HOLDER, diode, molded .718 dia. x .203 in. thick
	358-175			1	BUSHING, inner, brass, hex, 1/4 x .734 in. long
	132-023			1	SHELL, brass, 5/8 OD x 9/16 ID x 3/4 in.
	132-001			1	NUT, coupling
	132-002			1	SLEEVE, conductor, outer
	132-007			1	RING, snap
	132-028			1	INSULATOR
	132-029			1	CONDUCTOR, inner
	211-012			1	SCREW, 4-40 x 3/8 in. BHS Mounting Hardware: (not included)
19.	132-040			1	ADAPTER, Zamark #5, 1.050 sq.
	211-038			4	SCREW, 4-40 x 5/16 in. FHS, phillips
20.	132-016	101	361	1	NUT, retaining
	337-553	362		1	SHIELD, alum. 1/2 x 1 3/32 in.

FRAME GROUP (continued)

REF. NO.	PART NO.	SERIAL NO.		QTY.	DESCRIPTION
		EFF.	DISC.		
21.	132-040			1	ADAPTER, Zamark #5, 1.050 sq.
	211-038			4	SCREW, 4-40 x $\frac{5}{16}$ in. FHS, phillips
22.	387-476			1	PLATE, subpanel, front, alum. $15\frac{1}{16} \times 12\frac{7}{16} \times 1\frac{3}{16}$ in. Includes:
	Use				
23.	355-043			4	STUD, alum. $\frac{3}{8}$ -32 x .897 in. long
24.	354-056			1	RING, ornamental, stainless steel, $\frac{1}{8} \times 12\frac{5}{8} \times 15\frac{7}{8}$ in.
25.	200-269			2	COVER, pot, polypropylene, 1.115 dia. x $1\frac{5}{16}$ in. high
26.	Pot Mounting Hardware:
	210-012			2	LOCKWASHER, steel, pot internal $\frac{3}{8} \times \frac{1}{2}$ in.
	210-013			2	LOCKWASHER, steel, internal $\frac{3}{8} \times 1\frac{1}{16}$ in.
	210-207			1	LUG, solder, pot plain $\frac{3}{8}$ in.
	210-413			5	NUT, hex, brass, $\frac{3}{8}$ -32 x $\frac{1}{2}$ in.
	210-421			2	NUT, hex, alum. $\frac{3}{8}$ -32 x $\frac{1}{2} \times \frac{7}{16}$ in.
27.	352-006			2	HOLDER, melamine, double $\frac{7}{8} \times 1.088$ in. Mounting Hardware: (not included)
	211-031			2	SCREW, 4-40 x 1 in. FHS
	210-406			4	NUT, hex, brass, 4-40 x $\frac{3}{16}$ in.
28.	214-307			2	LATCH, plug-in assembly Consisting of:
	210-004			1	LOCKWASHER, steel, internal #4
	210-406			1	NUT, hex, brass, 4-40 x $\frac{3}{16}$ in.
	211-008			1	SCREW, 4-40 x $\frac{1}{4}$ in. BHS
	214-219			1	PIN, stainless steel, $\frac{5}{16} \times 1\frac{1}{32}$ in.
	214-221			1	LATCH, retaining, brass, $1\frac{1}{8} \times 1\frac{9}{32} \times 6$ in.
	214-235			1	SPRING, .375 x $1\frac{5}{32}$ in.
	367-030			1	HANDLE, carrier assembly Mounting Hardware: (not included)
	210-457			2	NUT, keps, steel, 6-32 x $\frac{5}{16}$ in.
29.	343-006			1	CLAMP, cable, $\frac{1}{2}$ in. plastic Mounting Hardware: (not included)
	212-045			1	SCREW, 8-32 x $\frac{1}{2}$ in. THS, phillips
	210-804			1	WASHER, steel, 8S x $\frac{3}{8}$ in.
	210-458			1	NUT, keps, steel, 8-32 x $1\frac{1}{32}$ in.
30.	381-193			1	BAR, alum. top support, $20\frac{7}{16}$ in. long, with handles Includes:
	343-073			4	CLAMP, cover, chrome plated Mounting Hardware: (not included)
	212-039			4	SCREW, 8-32 x $\frac{3}{8}$ in. THS, phillips
	381-073			2	BAR, alum. $\frac{3}{16} \times \frac{1}{2} \times 1\frac{3}{4}$ in.
31.	179-590			1	CABLE harness, pilot light

SUPPORT GROUP

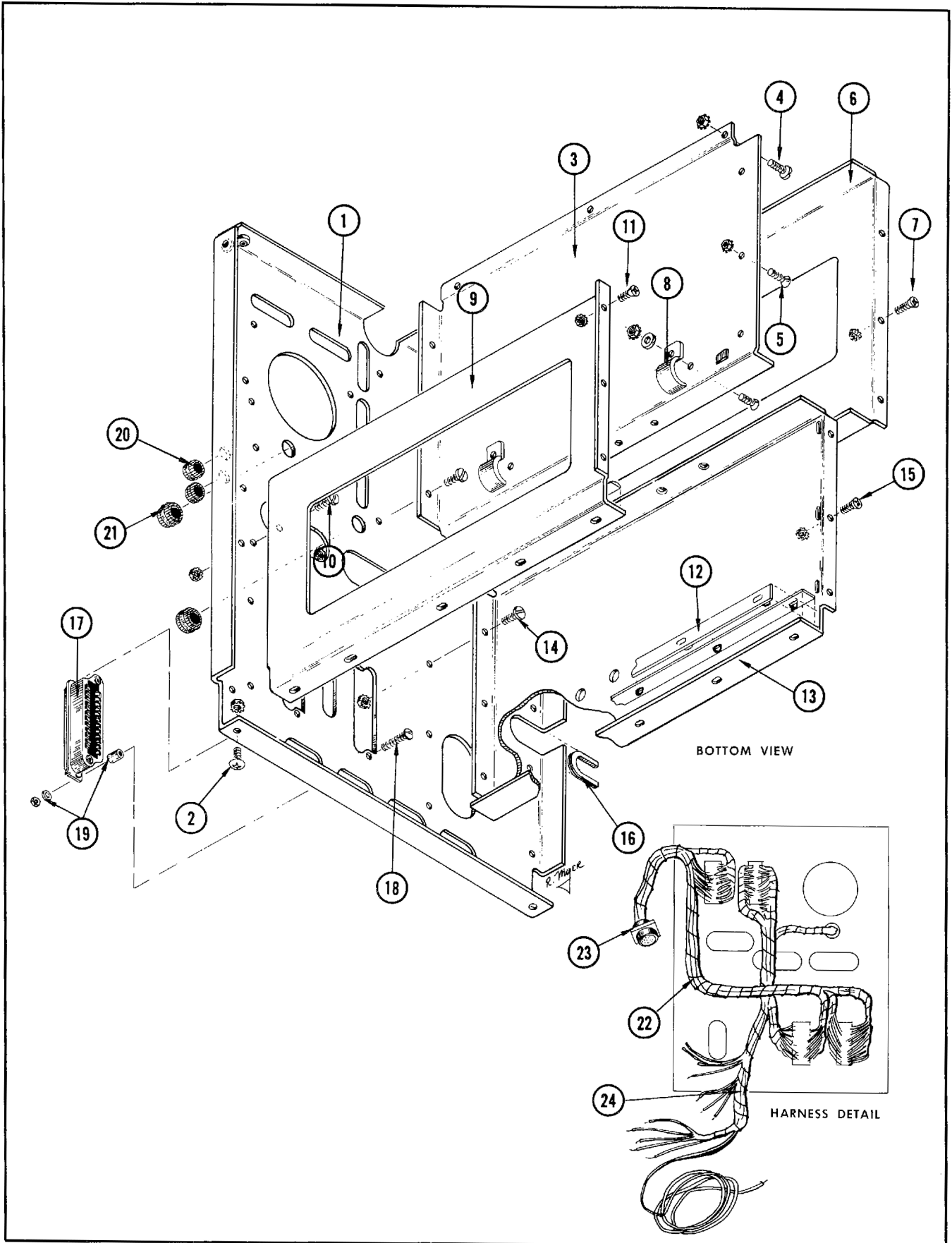

SUPPORT GROUP

REF. NO.	PART NO.	SERIAL NO.		QTY.	DESCRIPTION
		EFF.	DISC.		
1.	387-477			1	PLATE, bulkhead, alum. 15.687 x 12.250 x 3/4 in. Mounting Hardware: (not included)
2.	212-039			8	SCREW, 8-32 x 3/8 in. THS, phillips
3.	387-481			1	PLATE, vertical support, alum. 12 1/2 x 6 59/64 x 3/4 in. Mounting Hardware: (not included)
4.	211-510			6	SCREW, 6-32 x 3/8 in. BHS
5.	211-559			3	SCREW, 6-32 x 3/8 in. FHS, 100° CSK, phillips
	210-457			9	NUT, keps, steel, 6-32 x 5/16 in.
6.	387-499			1	PLATE, housing plug-in, alum. 12 1/2 x 6 59/64 x 1 1/16 in. Mounting Hardware: (not included)
7.	211-510			3	SCREW, 6-32 x 3/8 in. BHS
	211-559			3	SCREW, 6-32 x 3/8 in. FHS, 100° CSK, phillips
	210-457			6	NUT, keps, steel, 6-32 x 5/16 in.
8.	343-042			2	CLAMP, cable, 5/16 in. plastic (cut in half) Mounting Hardware: (not included)
	210-457			1	NUT, keps, steel, 6-32 x 5/16 in.
	210-803			1	WASHER, steel, 6L x 3/8 in.
	211-559			1	SCREW, 6-32 x 3/8 in. FHS, 100° CSK, phillips
9.	387-618			1	PLATE, housing, alum. 12 1/2 x 6.671 x 1 1/16 in. Mounting Hardware: (not included)
10.	211-510			3	SCREW, 6-32 x 3/8 in. BHS
11.	211-559			3	SCREW, 6-32 x 3/8 in. FHS, 100° CSK, phillips
	210-457			6	NUT, keps, steel, 6-32 x 5/16 in.
12.	351-052			4	GUIDE shoe, nylon, 12.093 long x .375 wide x .275 in. high
13.	387-617			1	PLATE, housing, alum. 12 1/2 x 6.671 x 3/4 in. Mounting Hardware: (not included)
14.	211-510			3	SCREW, 6-32 x 3/8 in. BHS
15.	211-559			3	SCREW, 6-32 x 3/8 in. FHS, 100° CSK, phillips
	210-457			6	NUT, keps, steel, 6-32 x 5/16 in.
16.	358-166			1	BUSHING, black polypropylene, 1.086 x 1 7/32 x 1 5/64 in. long
17.	131-148			4	CONNECTOR, chassis mount, 24 contact, female Mounting Hardware: (not included)
18.	211-016			2	SCREW, 4-40 x 5/8 in. RHS
19.	166-031			2	TUBE, spacer, alum. .180 ID x 1/4 OD x 1/4 in. long
	210-004			2	LOCKWASHER, steel internal #4
	210-406			2	NUT, hex, brass, 4-40 x 3/16 in.
20.	348-003			2	GROMMET, rubber, 5/16 in.
21.	348-012			2	GROMMET, rubber, 5/8 in.
22.	179-589			1	CABLE harness, read out Includes:
23.	131-212			1	CONNECTOR, 41 pin socket
24.	179-582	101	361	1	CABLE harness, bulkhead
	179-688	362		1	CABLE harness, bulkhead

TRANSISTOR POWER CHASSIS

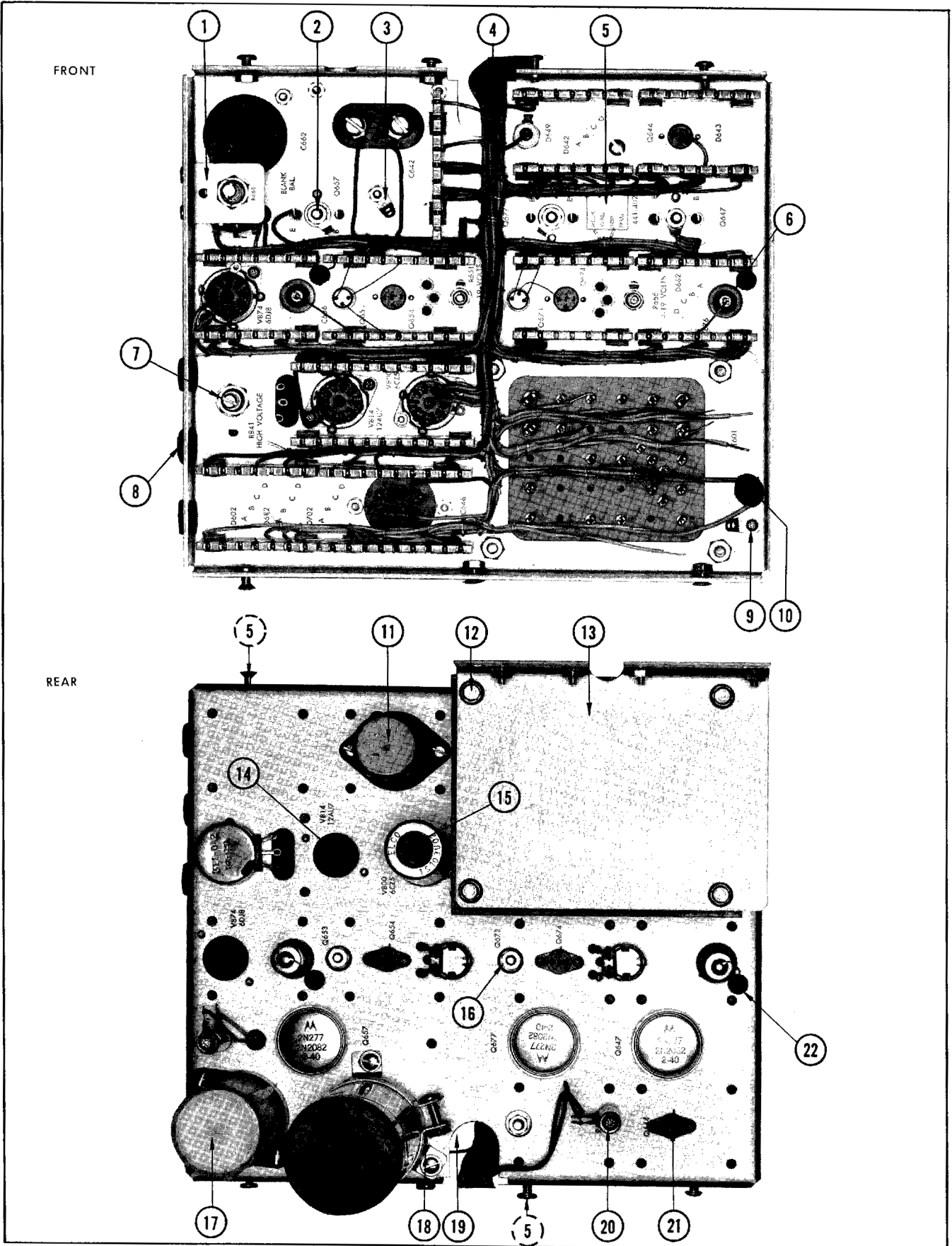

TRANSISTOR POWER CHASSIS

REF. NO.	PART NO.	SERIAL NO.		QTY.	DESCRIPTION
		EFF.	DISC.		
1.	406-734			1	BRACKET, alum. $\frac{9}{16} \times 1 \times 1\frac{1}{4}$ in. (Blanking Adj.) Mounting Hardware: (not included)
	211-504			2	SCREW, 6-32 x $\frac{1}{4}$ in. BHS
	210-413			1	NUT, hex, brass, $\frac{3}{8}$ -32 x $\frac{1}{2}$ in. (pot mounting hardware)
	210-840			1	WASHER, steel, .390 ID x $\frac{9}{16}$ OD (pot mounting hardware)
2.	Diode Mounting Hardware: (not included)
	210-410			1	NUT, hex, brass, 10-32 x $\frac{5}{16}$ in.
	210-206			1	LUG, solder, SE10 long
	210-813			1	WASHER, fiber #10 shouldered
	387-428			1	PLATE, mica, .002 x 1.062 in. dia.
3.	210-202			1	LUG, solder, SE6, with 2 wire holes
4.	179-585			1	CABLE harness, transistor power
5.	441-402			1	CHASSIS, power, left, alum. $9\frac{1}{32} \times 8\frac{5}{32} \times \frac{3}{4}$ in. Mounting Hardware: (not included)
	212-023			4	SCREW, 8-32 x $\frac{3}{8}$ in. BHS
	212-040			4	SCREW, 8-32 x $\frac{3}{8}$ in. 100° CSK, FHS, phillips
	210-458			8	NUT, keps, steel, 8-32 x $1\frac{1}{32}$ in.
6.	354-068			2	RING, securing, polyethylene, $\frac{1}{2}$ ID x $\frac{9}{16}$ OD x $\frac{1}{2}$ in. high
7.	210-413			1	NUT, hex, brass, $\frac{3}{8}$ -32 x $\frac{1}{2}$ in. (pot mounting hardware)
	210-840			1	WASHER, steel, .390 ID x $\frac{9}{16}$ OD (pot mounting hardware)
8.	348-005			1	GROMMET, rubber, $\frac{1}{2}$ in.
9.	210-201			1	LUG, solder, SE4
	213-044			1	SCREW, thread cutting, 5-32 x $\frac{3}{16}$ in. Pan H steel, phillips
10.	348-004			3	GROMMET, rubber, $\frac{3}{8}$ in.
11.	200-256			1	COVER, capacitor, polyethylene, $2\frac{1}{32} \times 1$ in. dia.
	200-356				COVER, capacitor, black plastic, $2\frac{1}{16} \times 1$ in. dia.
	386-252			1	PLATE, fiber small Mounting Hardware: (not included)
	211-534			2	SCREW, 6-32 x $\frac{5}{16}$ in. PHS, with lockwasher
	210-006			2	LOCKWASHER, steel, internal #6
	210-407			2	NUT, hex, brass, 6-32 x $\frac{1}{4}$ in.
12.	Transformer Mounting Hardware: (not included)
	212-542			4	SCREW, hex, HS, 10-32 x 5 in.
	210-812			4	WASHER, fiber #10
	210-010			4	LOCKWASHER, steel, internal #10
	210-445			4	NUT, hex, steel, 10-32 x $\frac{3}{8} \times \frac{1}{8}$ in. thick
13.	406-733			1	BRACKET, alum. $4\frac{1}{16} \times 3\frac{23}{32} \times 2\frac{7}{32}$ in. Mounting Hardware: (not included)
	212-040			4	SCREW, 8-32 x $\frac{3}{8}$ in. 100° FHS, phillips
	210-458			4	NUT, keps, steel, 8-32 x $1\frac{1}{32}$ in.

TRANSISTOR POWER CHASSIS (continued)

REF. NO.	PART NO.	SERIAL NO.		QTY.	DESCRIPTION
		EFF.	DISC.		
14.	136-015			3	SOCKET, STM9G Mounting Hardware: (not included)
	213-044			2	SCREW, thread cutting, 5-32 x 3/16 in. Pan H steel, phillips
15.	337-005			1	SHIELD, socket, 29/32 in. ID
	337-009			1	SHIELD, tube, 1 1/32 ID x 2 13/32 in. high, with spring Mounting Hardware: (not included)
	211-033			2	SCREW, 4-40 x 5/16 in. Pan HS, with lockwasher
	210-004			2	LOCKWASHER, steel, internal #4
	210-406			2	NUT, hex, brass, 4-40 x 3/16 in.
16.	Diode Mounting Hardware:
	210-409			1	NUT, hex, brass, 8-32 x 5/16 in.
	210-008			1	LOCKWASHER, steel, internal #8
	210-813			1	WASHER, fiber #10 shouldered
	210-909			1	WASHER, mica, .625 OD x .196 ID x .002 in. thick
17.	200-293			1	COVER, capacitor, polyethylene, 2 7/16 x 1.365 in. ID
	200-361				COVER, capacitor, black plastic, 2 7/16 x 1.365 in. ID
	386-254			1	PLATE, fiber large Mounting Hardware: (not included)
	211-543			2	SCREW, 6-32 x 5/16 in. RHS
	210-006			2	LOCKWASHER, steel, internal #6
	210-407			2	NUT, hex, brass, 6-32 x 1/4 in.
18.	343-082			1	CLAMP, 1 13/16 in. dia. with 3 mounting feet Mounting Hardware: (not included)
	212-509			1	SCREW, 10-32 x 5/8 in. BHS
	211-507			3	SCREW, 6-32 x 5/16 in. BHS
	210-006			3	LOCKWASHER, steel, internal #6
	210-010			1	LOCKWASHER, steel, internal #10
	210-803			3	WASHER, steel, 6L x 3/8 in.
	210-407			3	NUT, hex, brass, 6-32 x 1/4 in.
	210-410			1	NUT, hex, brass, 10-32 x 5/16 in.
19.	358-166			1	BUSHING, black polypropylene, 1.086 x 1 7/32 x 1 5/64 in.
20.	Resistor Mounting Hardware: (not included)
	210-478			1	NUT, hex, alum. 5/16 x 2 1/32 in. long
	210-601			1	EYELET, brass, tapered barrel
	211-507			1	SCREW, 6-32 x 5/16 in. BHS
	211-553			1	SCREW, 6-32 x 1 1/2 in. RHS, phillips
21.	136-095			3	SOCKET, 4 pin transistor Mounting Hardware: (not included)
	211-057			2	SCREW, 2-56 x 5/16 in. RHS, phillips
22.	348-002			3	GROMMET, rubber, 1/4 in.

HORIZONTAL PREAMPLIFIER CHASSIS

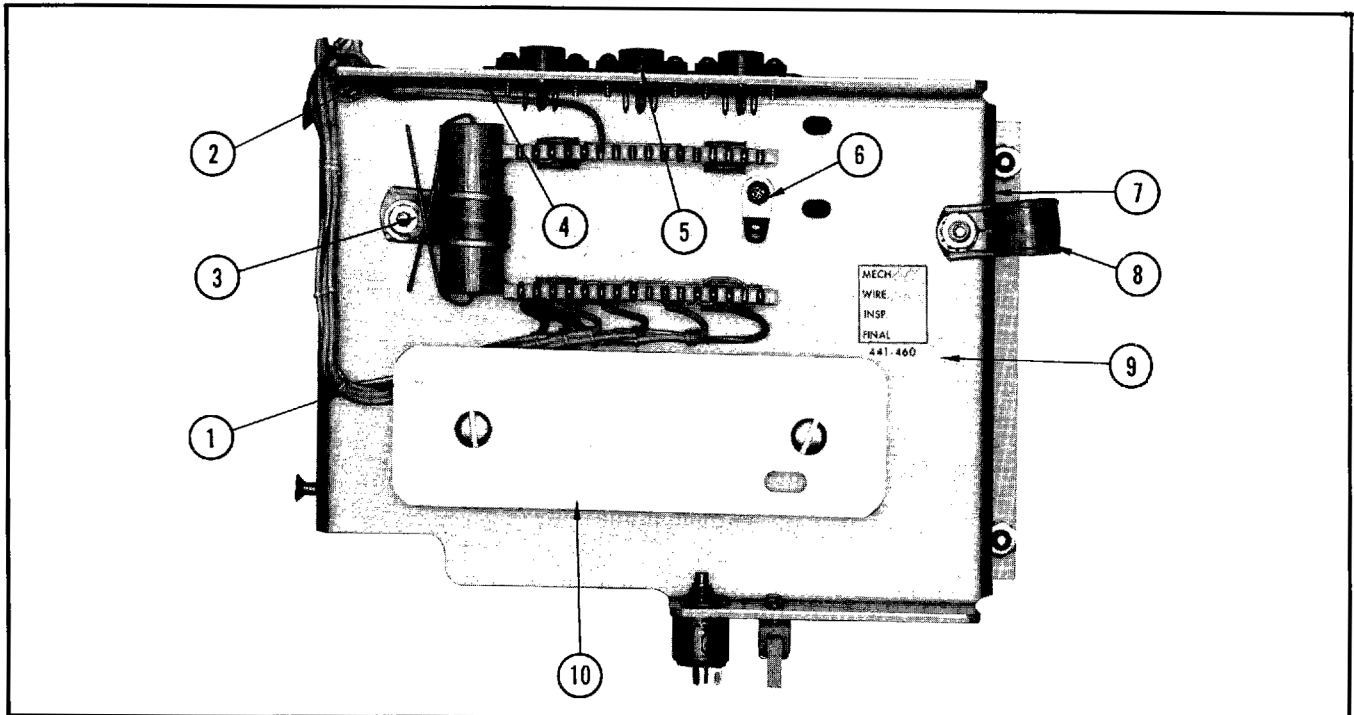

REF. NO.	PART NO.	SERIAL NO.		QTY.	DESCRIPTION
		EFF.	DISC.		
1.	179-587			1	CABLE harness, Horiz. Preamp
2.	348-002			1	GROMMET, rubber, 1/4 in.
3.	343-007			1	CLAMP, cable, 5/8 in. plastic Mounting Hardware: (not included)
	210-006			1	LOCKWASHER, steel, internal #6
	210-407			1	NUT, hex, brass, 6-32 x 1/4 in.
	210-803			1	WASHER, steel, 6L x 3/8 in.
	211-510			1	SCREW, 6-32 x 3/8 in. BHS
4.	348-031			4	GROMMET, polypropylene, snap-in, 1/4 in. dia.
5.	136-095			3	SOCKET, 4 pin transistor Mounting Hardware: (not included)
	211-057			2	SCREW, 2-56 x 5/16 in. RHS, phillips
6.	210-201			1	LUG, solder, SE4
	213-044			1	SCREW, thread cutting, 5-32 x 3/16 in. Pan HS (mounting screw)
7.	348-003			1	GROMMET, rubber, 5/16 in. (on side of chassis)
8.	343-005			1	CLAMP, cable, 7/16 in. plastic Mounting Hardware: (not included)
	210-006			1	LOCKWASHER, steel, internal #6
	210-407			1	NUT, hex, brass, 6-32 x 1/4 in.
	210-803			1	WASHER, steel, 6L x 3/8 in.
	211-510			1	SCREW, 6-32 x 3/8 in. BHS
9.	441-403	101	361	1	CHASSIS, alum. 4 3/4 x 6 3/16 x 2 23/64 in.
	441-460	362		1	CHASSIS, alum. 4 3/4 x 6 3/16 x 2 23/64 in.
10.	387-483			1	PLATE, drum, alum. 4 7/16 x 1 7/16 in. Mounting Hardware: (not included)
	212-001			3	SCREW, 8-32 x 1/4 in. BHS
	212-002			1	SCREW, 8-32 x 1/4 in. FHS, 100°
	385-101			2	ROD, nylon, 5/8 x 3/8 in.

TUBE POWER CHASSIS

REF. NO.	PART NO.	SERIAL NO.		QTY.	DESCRIPTION
		EFF.	DISC.		
1.	179-446			1	CABLE harness, tube power
2.	441-401			1	CHASSIS, power, right, alum. 12 $\frac{1}{4}$ x 8 $\frac{15}{32}$ x $\frac{3}{4}$ in. Mounting Hardware: (not included)
	212-040			3	SCREW, 8-32 x $\frac{3}{8}$ in. 100° FHS, phillips
	211-510			3	SCREW, 8-32 x $\frac{3}{8}$ in. BHS
	210-458			6	NUT, keps, steel, 8-32 x $\frac{11}{32}$ in.
3.	Pg. 6-28			1	SWITCH, Thermal Cut Out
4.	348-005			1	GROMMET, rubber, $\frac{1}{2}$ in.
5.	343-009			1	CLAMP, cable, $\frac{7}{8}$ in. plastic
	212-004			1	SCREW, 8-32 x $\frac{5}{16}$ in. BHS (mounting screw)
6.	Pot Mounting Hardware: (not included)
	210-444			1	NUT, hex, alum. $\frac{1}{2}$ x $\frac{5}{8}$ in. long
	210-840			1	WASHER, steel, .390 ID x $\frac{9}{16}$ in. OD
7.	211-503			2	SCREW, 6-32 x $\frac{3}{16}$ in. BHS (relay mounting hardware)
8.	210-201			1	LUG, solder, SE4
	213-044			1	SCREW, thread cutting, 5-32 x $\frac{3}{16}$ in. Pan H steel, phillips
9.	Resistor Mounting Hardware: (not included)
	210-808			1	WASHER, brass, centering
	212-037			1	SCREW, 8-32 x $1\frac{3}{4}$ in. Fil HS
	210-462			1	NUT, hex, alum. 8-32 x $\frac{1}{2}$ x $\frac{9}{16}$ in.
	212-004			1	SCREW, 8-32 x $\frac{5}{16}$ in. BHS
10.	348-002			1	GROMMET, rubber, $\frac{1}{4}$ in.
11.	136-015			4	SOCKET, STM9G Mounting Hardware: (not included)
	213-044			2	SCREW, thread cutting, 5-32 x $\frac{3}{16}$ in. Pan H steel phillips
12.	136-008			3	SOCKET, STM7G Mounting Hardware: (not included)
	213-044			2	SCREW, thread cutting, 5-32 x $\frac{3}{16}$ in. Pan H steel phillips
13.	358-166			1	BUSHING, black polypropylene, 1.086 x $1\frac{7}{32}$ x $1\frac{5}{64}$ in.
14.	200-261			1	COVER, polyethylene, 4 $\frac{1}{16}$ x 1.365 in. dia.
	200-364				COVER, black plastic, 4 $\frac{1}{16}$ x 1.365 in. dia.
	386-255			1	PLATE, metal large
	Capacitor Mounting Hardware: (not included)
	211-516			2	SCREW, 6-32 x $\frac{7}{8}$ in. BHS
	166-035			2	TUBE, spacer, alum. .180 ID x $\frac{1}{4}$ OD x $\frac{1}{2}$ in. long
	210-006			4	LOCKWASHER, steel, internal #6
	210-407			2	NUT, hex, brass, 6-32 x $\frac{1}{4}$ in.
15.	386-253			1	PLATE, metal small
	Capacitor Mounting Hardware: (not included)
	211-534			2	SCREW, 6-32 x $\frac{5}{16}$ in. PHS, with lockwasher
	210-006			2	LOCKWASHER, steel, internal #6
	210-407			2	NUT, hex, brass, 6-32 x $\frac{1}{4}$ in.

TUBE POWER CHASSIS (continued)

REF. NO.	PART NO.	SERIAL NO.		QTY.	DESCRIPTION
		EFF.	DISC.		
16.	343-074			2	CLAMP, tube, top hat Mounting Hardware: (not included)
	355-070			1	STUD, stainless steel, 8-32 x 4 ³ / ₄ in. long
	210-458			2	NUT, keps, steel, 8-32 x 1 ¹ / ₃₂ in.
17.	337-005			1	SHIELD, socket, 2 ⁹ / ₃₂ in. ID
	337-009			1	SHIELD, tube, 1 ¹ / ₃₂ ID x 2 ¹³ / ₃₂ in. high, with spring
18.	Capacitor Mounting Hardware: (not included)
	211-507			2	SCREW, 6-32 x 5 ⁵ / ₁₆ in. BHS
	210-803			2	WASHER, steel, 6L x 3 ³ / ₈ in.
	210-006			2	LOCKWASHER, steel, internal #6
	210-407			2	NUT, hex, brass, 6-32 x 1 ¹ / ₄ in.
	19.	200-261			2
200-364					COVER, black plastic, 4 ¹ / ₁₆ x 1.365 dia.
386-254				2	PLATE, fiber, large
.....				..	Capacitor Mounting Hardware: (not included)
211-516				2	SCREW, 6-32 x 7 ⁷ / ₈ in. BHS
166-035				2	TUBE, spacer, alum. .180 ID x 1 ¹ / ₄ OD x 1 ¹ / ₂ in. long
210-006				4	LOCKWASHER, steel, internal #6
210-407				2	NUT, hex, brass, 6-32 x 1 ¹ / ₄ in.
20.	337-005			1	SHIELD, socket, 2 ⁹ / ₃₂ ID
	337-008			1	SHIELD, tube, 1 ¹ / ₃₂ ID x 1 ¹⁵ / ₁₆ in. high, with spring
21.	136-013			3	SOCKET, STM8 Mounting Hardware: (not included)
	211-538			2	SCREW, 6-32 x 5 ⁵ / ₁₆ in. FHS 100° CSK, phillips
	210-006			2	LOCKWASHER, steel, internal #6
	210-407			2	NUT, hex, brass, 6-32 x 1 ¹ / ₄ in.
	22.	200-257			1
200-357					COVER, black plastic, 1.000 ID x 2 ⁹ / ₁₆ in.
386-252				1	PLATE, fiber small
.....				..	Capacitor Mounting Hardware: (not included)
211-534				2	SCREW, 6-32 x 5 ⁵ / ₁₆ in. PHS, with lockwasher
210-006				2	LOCKWASHER, steel, internal #6
	210-407			2	NUT, hex, brass, 6-32 x 1 ¹ / ₄ in.

50-OHM PLUG-IN CONNECTING BRACKETS

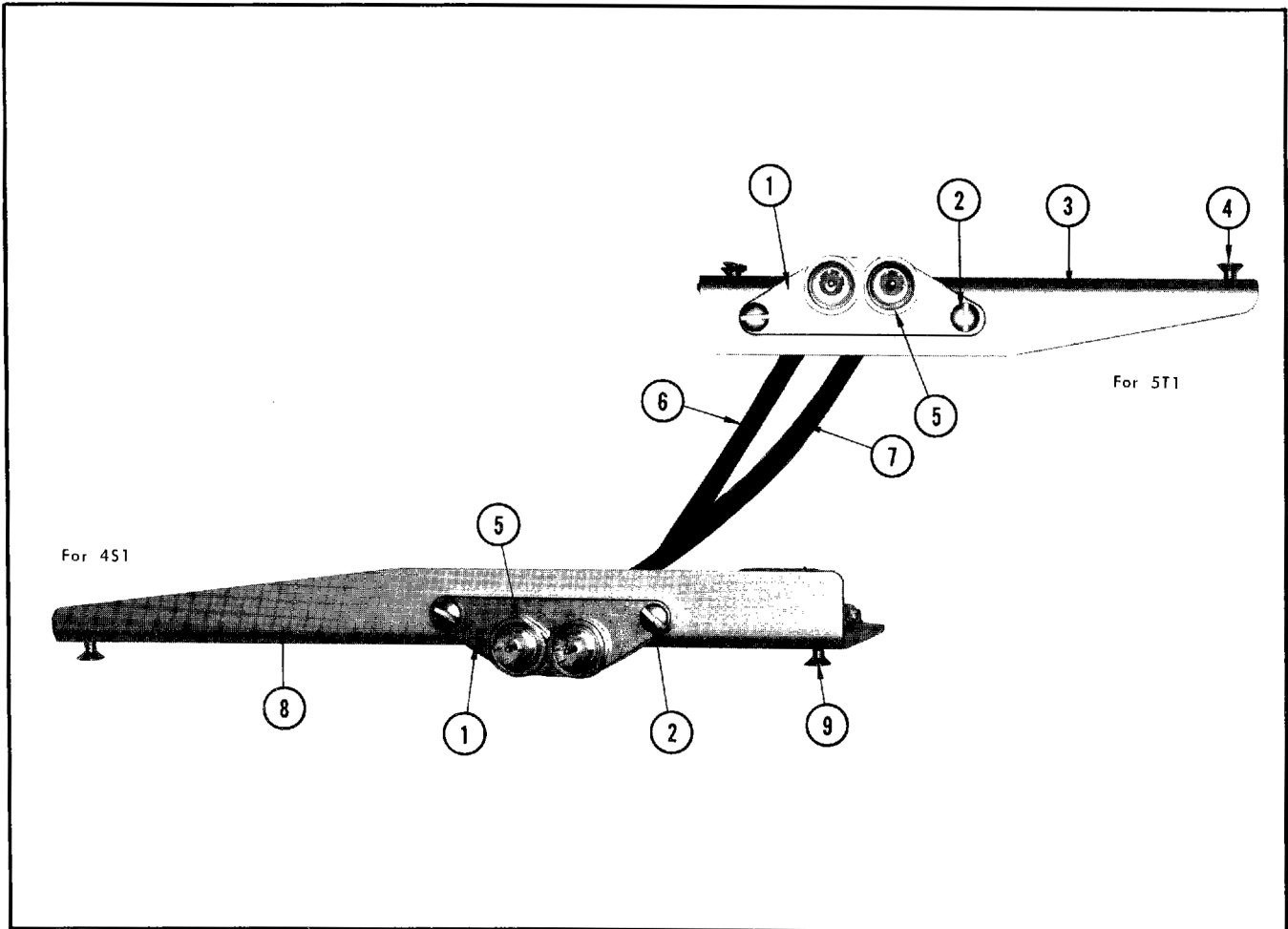

REF. NO.	PART NO.	SERIAL NO.		QTY.	DESCRIPTION
		EFF.	DISC.		
1.	426-153			2	MOUNT, 50 Ω line connector Mounting Hardware: (not included)
2.	211-511			2	SCREW, 6-32 x 1/2 in. BHS
	210-006			2	LOCKWASHER, steel, int. #6
	210-407			2	NUT, hex, brass, 6-32 x 1/4 in.
3.	406-766			1	BRACKET, support, alum., 5 ¹¹ / ₃₂ x 2 x 3/4 in. Mounting Hardware: (not included)
4.	211-559			3	SCREW, 6-32 x 3/8 in. 100° CSK, phillips, FHS
	210-457			3	NUT, keps, steel, 6-32 x 5/16 in.
5.	210-455			4	NUT, hex, steel, 1/4-28 x 3/8 x 3/32 in. (cable mounting)
6.	175-230			1	CABLE, assembly, Inboard
7.	175-231			1	CABLE, assembly, Outboard
8.	406-767			1	BRACKET, support, alum., 7 ²⁷ / ₃₂ x 2 1/2 x 3/4 in. Mounting Hardware: (not included)
9.	211-559			3	SCREW, 6-32 x 3/8 in. 100° CSK, phillips, FHS
	210-457			3	NUT, keps, steel, 6-32 x 5/16 in.

VERTICAL AMPLIFIER CHASSIS

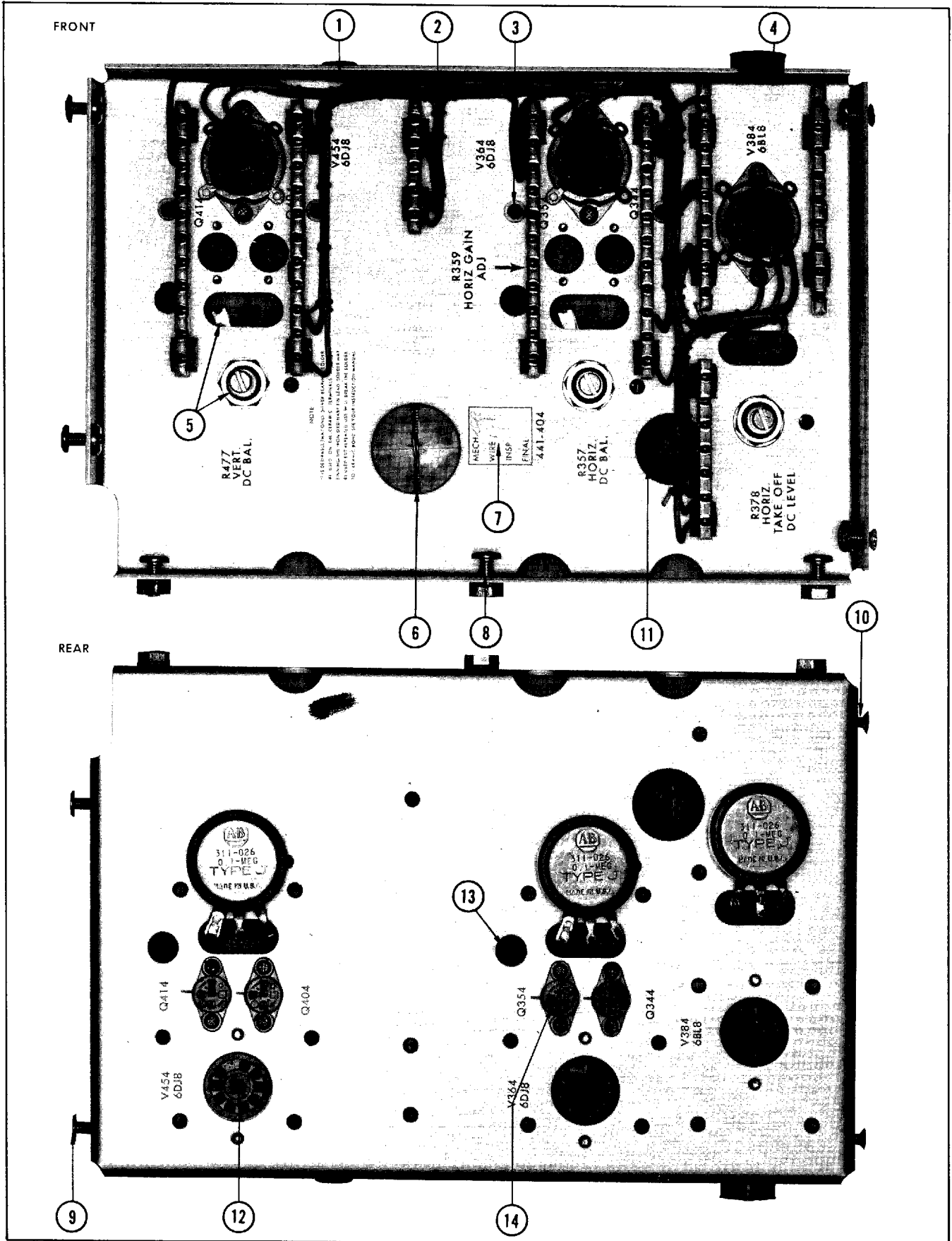

VERTICAL AMPLIFIER CHASSIS

REF. NO.	PART NO.	SERIAL NO.		QTY.	DESCRIPTION
		EFF.	DISC.		
1.	348-003			1	GROMMET, rubber, $\frac{5}{16}$ in.
2.	179-583			1	CABLE harness
3.	348-031			4	GROMMET, polypropylene, snap-in, $\frac{1}{4}$ in. dia.
4.	210-438			2	NUT, hex, brass, 1-72 x $\frac{5}{32}$ in. (pot mounting)
5.	Pot Mounting Hardware: (not included)
	210-413			3	NUT, hex, brass, $\frac{3}{8}$ -32 x $\frac{1}{2}$ in.
	210-840			3	WASHER, steel, .390 ID x $\frac{9}{16}$ in. OD
	210-012			2	LOCKWASHER, steel, pot internal $\frac{3}{8}$ x $\frac{1}{2}$ in.
	210-207			2	LUG, solder, pot plain, $\frac{3}{8}$ in.
6.	214-210			1	SPOOL, zytel, 1 in. OD x $\frac{9}{16}$ in long w/solder
7.	441-404			1	CHASSIS, alum, $8\frac{7}{16}$ x $5\frac{9}{16}$ x $1\frac{1}{16}$ in. Mounting Hardware: (not included)
8.	212-023			3	SCREW, 8-32 x $\frac{3}{8}$ in. BHS
	210-458			5	NUT, keps, steel, 8-32 x $1\frac{1}{32}$ in.
9.	212-039			2	SCREW, 8-32 x $\frac{3}{8}$ in. THS, phillips
10.	212-040			2	SCREW, 8-32 x $\frac{3}{8}$ in. 100° FHS, phillips
11.	348-012			1	GROMMET, rubber, $\frac{5}{8}$ in.
12.	136-015			3	SOCKET, STM9G Mounting Hardware: (not included)
	213-044			6	SCREW, thread cutting, 5-32 x $\frac{3}{16}$ in. PHS, phillips
13.	348-002			2	GROMMET, rubber, $\frac{1}{4}$ in.
14.	136-095			4	SOCKET, 4 pin transistor Mounting Hardware: (not included)
	211-057			2	SCREW, 2-56 x $\frac{5}{16}$ in. RHS, phillips

CALIBRATOR CHASSIS

TOP

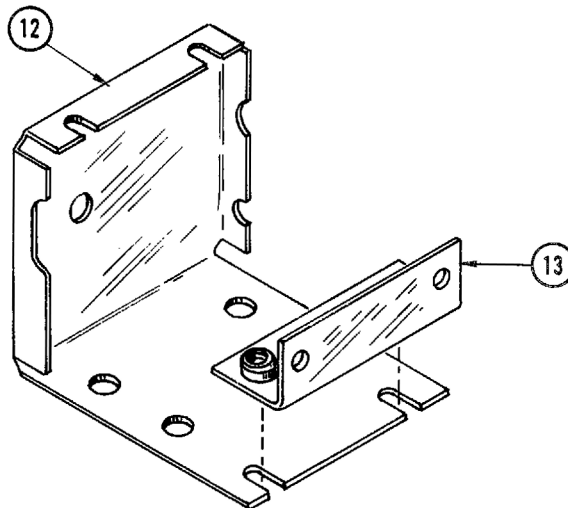
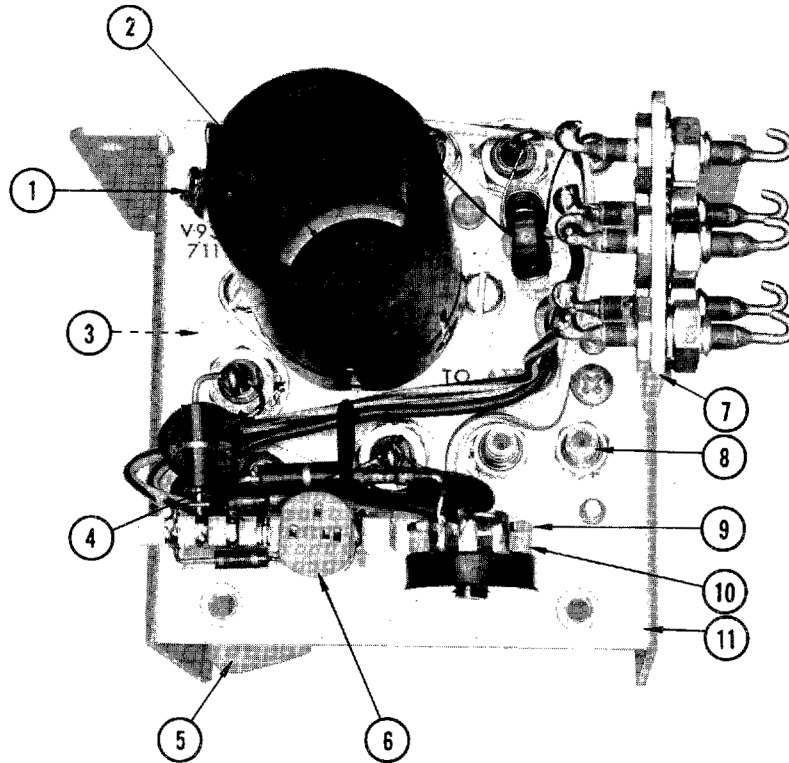

CALIBRATOR CHASSIS

REF. NO.	PART NO.	SERIAL NO.		QTY.	DESCRIPTION
		EFF.	DISC.		
1.	129-006			1	POST, connecting, insulated
	210-202			2	LUG, solder, SE6, with 2 wire holes
	210-407			1	NUT, hex, brass, 6-32 x 1/4 in.
2.	136-072			1	SOCKET, 9 pin, UHF miniature
	337-005			1	SHIELD, socket, 29/32 ID
	337-491			1	SHIELD, tube shell, black anodized Mounting Hardware: (not included)
	211-033			2	SCREW, 4-40 x 5/16 in. Pan HS, with lockwasher
	210-004			2	LOCKWASHER, steel, internal #4
	210-406			2	NUT, hex, brass, 4-40 x 3/16 in.
3.	426-121			2	MOUNT, toroid, nylon, 15/32 x 1/8 x 9/64 in. Mounting Hardware: (not included)
	213-044			2	SCREW, thread cutting, 5-32 x 3/16 in. Pan H steel, phillips
4.	210-201			3	LUG, solder, SE4 Mounting Hardware: (not included)
	213-044			1	SCREW, thread cutting, 5-32 x 3/16 in. Pan H steel, phillips
5.	426-154			1	MOUNT, toroid, holder, nylon, .380 in. wide
6.	136-062			1	SOCKET, 4 pin tube
7.	406-780			1	BRACKET, alum. 1 3/8 x 3 1/32 x 7/16 in. Mounting Hardware: (not included)
	213-044			2	SCREW, thread cutting, 5-32 x 3/16 in. Pan H steel, phillips
8.	131-156			2	CONNECTOR, coax, miniature, chassis mount
9.	210-438			8	NUT, hex, brass, 1-72 x 5/32 in. (pot mounting)
10.	406-635			4	BRACKET, delrin, 1/2 x .576 in. Mounting Hardware: (not included)
	213-044			2	SCREW, thread cutting, 5-32 x 3/16 in. Pan H steel, phillips
11.	441-425			1	CHASSIS, alum. 2 15/32 x 2 35/64 in. Mounting Hardware: (not included)
	210-457			4	NUT, keps, steel, 6-32 x 5/16 in.
12.	337-488			1	SHIELD, alum. 2 29/64 x 2 9/16 x 1 5/32 in. Mounting Hardware: (not included)
	211-504			4	SCREW, 6-32 x 1/4 in. BHS
13.	406-774			1	BRACKET, alum. 1 29/32 x 1 1/16 x 1 5/32 in. Mounting Hardware: (not included)
	210-457			2	NUT, keps, steel, 6-32 x 5/16 in.

FOCUS AND INTENSITY

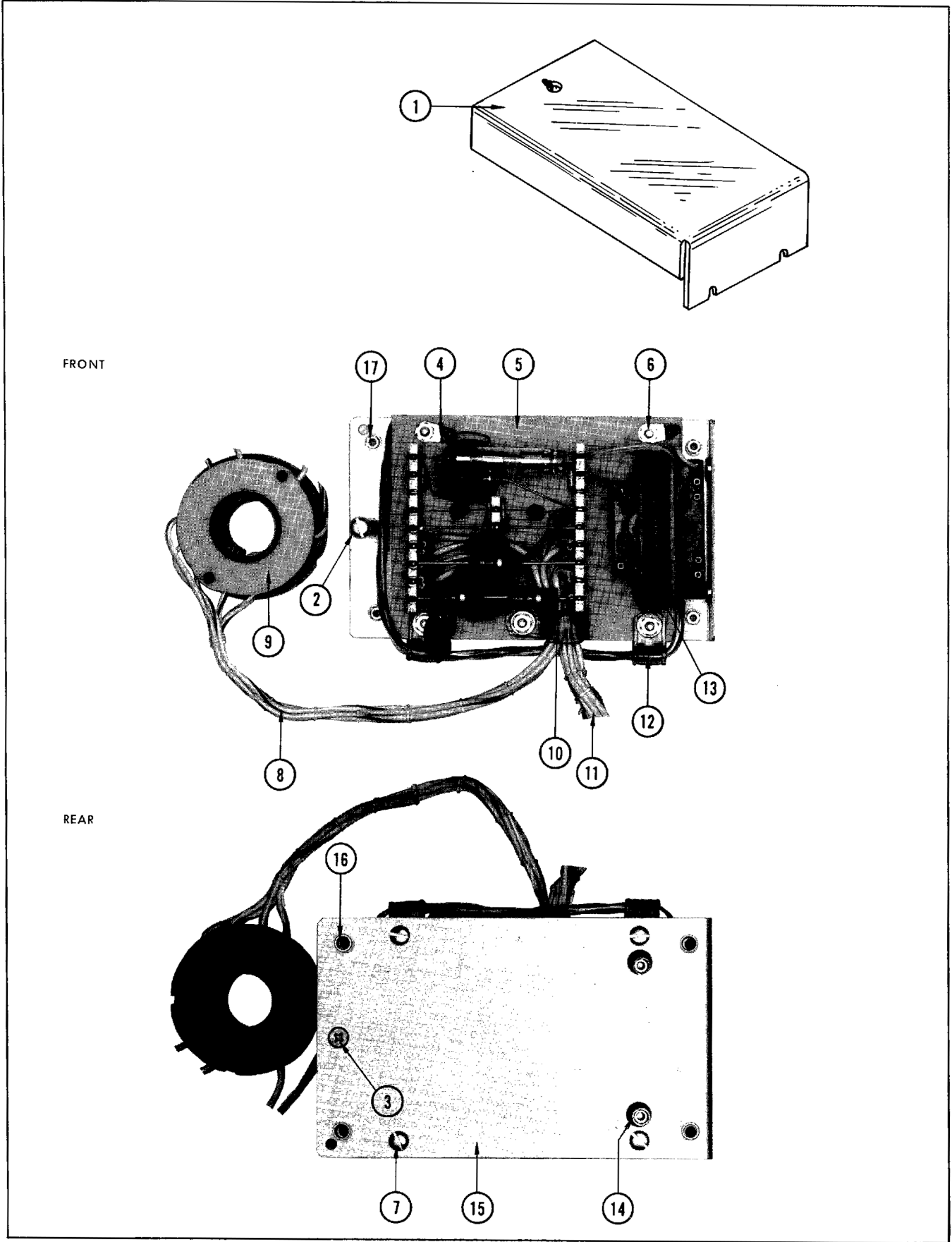

FOCUS AND INTENSITY

REF. NO.	PART NO.	SERIAL NO.		QTY.	DESCRIPTION
		EFF.	DISC.		
1.	337-473			1	SHIELD, H.V. alum. $5\frac{1}{2} \times 3\frac{1}{16} \times 2\frac{15}{32}$ in. Mounting Hardware: (not included)
2.	211-504			1	SCREW, 6-32 x $\frac{1}{4}$ in. BHS
	211-507			2	SCREW, 6-32 x $\frac{5}{16}$ in. BHS
	385-020			1	ROD, nylon, $\frac{5}{16}$ dia. x $2\frac{3}{8}$ in.
3.	211-538			1	SCREW, 6-32 x $\frac{5}{16}$ in. FHS, 100° CSK, phillips
4.	210-202			2	LUG, solder, SE6, with 2 wire holes
5.	387-484			1	PLATE, H.V. $1\frac{3}{32}$ textolite, $3\frac{3}{8} \times 4\frac{5}{16}$ in. Mounting Hardware: (not included)
6.	210-006			4	LOCKWASHER, steel, internal #6
	210-803			2	WASHER, steel, $6L \times \frac{3}{8}$ in.
	210-407			4	NUT, hex, brass, 6-32 x $\frac{1}{4}$ in.
7.	211-516			2	SCREW, 6-32 x $\frac{7}{8}$ in. BHS
	211-517			2	SCREW, 6-32 x 1 in. BHS
8.	179-591			1	CABLE harness, CRT socket Includes:
9.	136-128				SOCKET, CRT assembly Consisting of:
	131-178			9	CONNECTOR, cable end, CRT for 14 pin
	136-117			1	SOCKET, CRT 14 pin, $\frac{5}{8}$ in. thick, without leads
	213-086			2	SCREW, thread cutting, 2-32 x $\frac{7}{16}$ in. PHS
	387-393			1	PLATE, back, CRT socket, .125 thick x 2.185 OD
10.	343-007			1	CLAMP, cable, $\frac{5}{8}$ in. plastic Mounting Hardware: (not included)
	210-006			1	LOCKWASHER, steel, internal #6
	210-803			1	WASHER, steel, $6L \times \frac{3}{8}$ in.
	210-407			1	NUT, hex, brass, 6-32 x $\frac{1}{4}$ in.
	210-510			1	SCREW, 6-32 x $\frac{3}{8}$ in. BHS
11.	179-588			1	CABLE harness, F&I
12.	343-002			2	CLAMP, cable, $\frac{3}{16}$ in. plastic
13.	346-001			1	STRAP, mounting, alum. $\frac{5}{16} \times 4\frac{1}{4}$ in. Mounting Hardware: (not included)
14.	210-004			2	LOCKWASHER, steel, internal #4
	210-406			2	NUT, hex, brass, 4-40 x $\frac{3}{16}$ in.
15.	387-482			1	PLATE, alum. $5\frac{1}{2} \times 3\frac{3}{8} \times \frac{1}{2}$ (H.V. Support) Mounting Hardware: (not included)
16.	166-107			4	TUBE, spacing, alum. .180 ID x $\frac{1}{4}$ OD x $\frac{7}{32}$ in.
17.	210-004			4	LOCKWASHER, steel, internal #4
	210-406			4	NUT, hex, brass, 4-40 x $\frac{3}{16}$ in.

CRT SHIELD

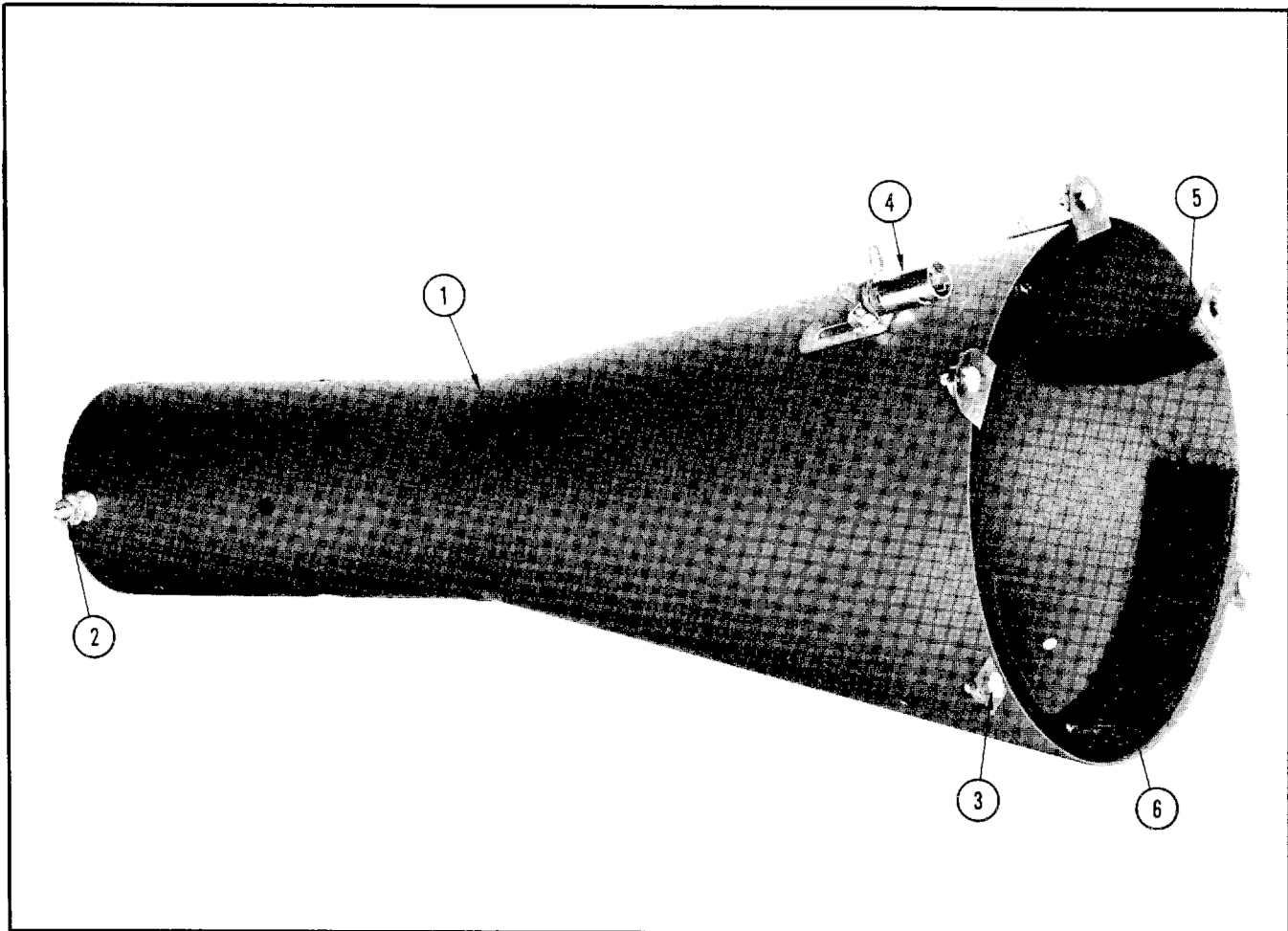

REF. NO.	PART NO.	SERIAL NO.		QTY.	DESCRIPTION
		EFF.	DISC.		
1.	337-364			1	SHIELD, CRT Mounting Hardware: (not included)
2.	166-107			2	TUBE, spacing, alum. .180 ID x 1/4 OD x 7/32 in.
	210-803			4	WASHER, steel, 6L x 3/8 in.
	210-457			2	NUT, keps, steel, 6-32 x 5/16 in.
	211-513			2	SCREW, 6-32 x 5/8 in. BHS
3.	211-559			5	SCREW, 6-32 x 3/8 in. 100° CSK, phillips, FHS
	210-457			5	NUT, keps, steel, 6-32 x 5/16 in.
4.	136-035			2	SOCKET, graticule light, with ground lug Mounting Hardware: (not included)
	211-534			1	SCREW, 6-32 x 5/16 in. PHS, with lockwasher
	210-803			1	WASHER, steel, 6L x 3/8 in.
	210-457			1	NUT, keps, steel, 6-32 x 5/16 in.
5.	406-239			3	BRACKET, special phosphor, bronze, 3/4 x 2 1/4 x 5/8 in.
6.	124-022			1	STRIP, felt, grey, 3/16 x 1 x 8 in.

CRT BRACKET AND ROTATOR

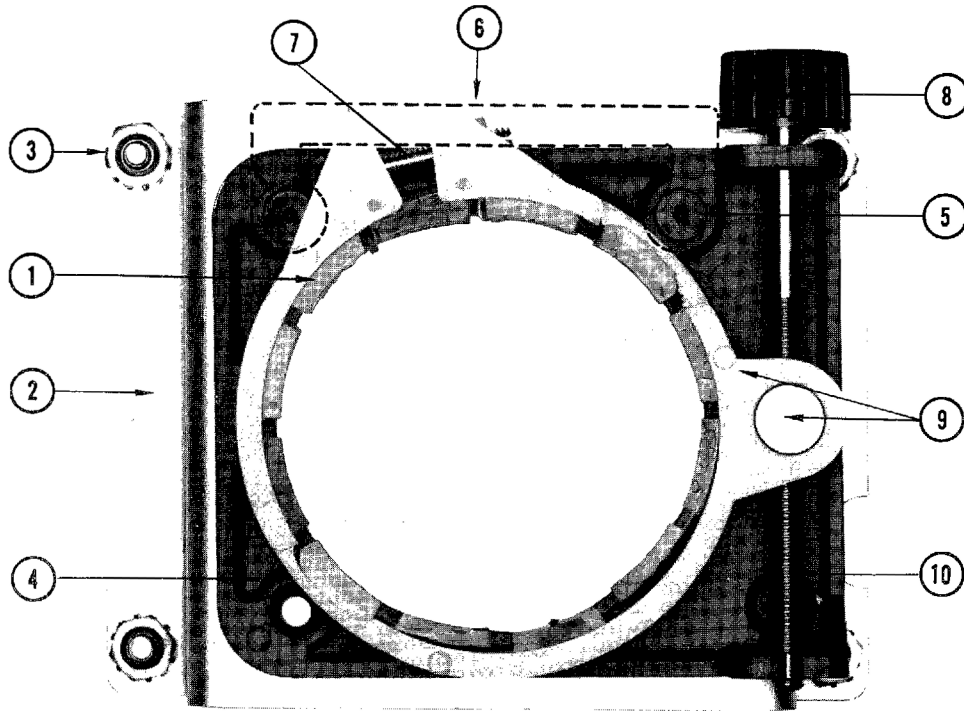

REF. NO.	PART NO.	SERIAL NO.		QTY.	DESCRIPTION
		EFF.	DISC.		
1.	354-078	101	249	1	RING, nylon, urethane taper, $1\frac{3}{16} \times 2\frac{11}{16}$ OD x 2.4 ID
	354-178	250		1	RING, nylon, urethane taper, $1\frac{3}{16} \times 2\frac{11}{16}$ OD x $2\frac{17}{64}$ ID
2.	432-022			1	BASE, alum. $2\frac{3}{4} \times 3\frac{3}{16} \times \frac{9}{16}$ in. Mounting Hardware: (not included)
3.	212-023			4	SCREW, 8-32 x $\frac{3}{8}$ in. BHS
	210-458			4	NUT, keps, steel, 8-32 x $\frac{1}{32}$ in.
4.	406-735			1	BRACKET, CRT Rotator, alum. $4\frac{7}{32} \times 3\frac{3}{16} \times 1\frac{5}{8}$ in. Mounting Hardware:
5.	211-561			2	SCREW, 6-32 x $\frac{3}{8}$ in. hex, socket, FH cap
6.	210-503			1	NUT, alum. $2\frac{1}{32} \times 2\frac{1}{2}$ in.
7.	211-560			1	SCREW, 6-32 x 1 in. RHS
	210-407			1	NUT, hex, brass, 6-32 x $\frac{1}{4}$ in.
8.	366-032			1	KNOB, small red
9.	354-103			1	RING, clamping assembly Includes:
	210-502			1	NUT, brass, 10-32 x $\frac{3}{8}$ in.
10.	355-049			1	STUD, steel, $\frac{3}{16} \times 3\frac{1}{4} \times 10-32$ in.

FAN

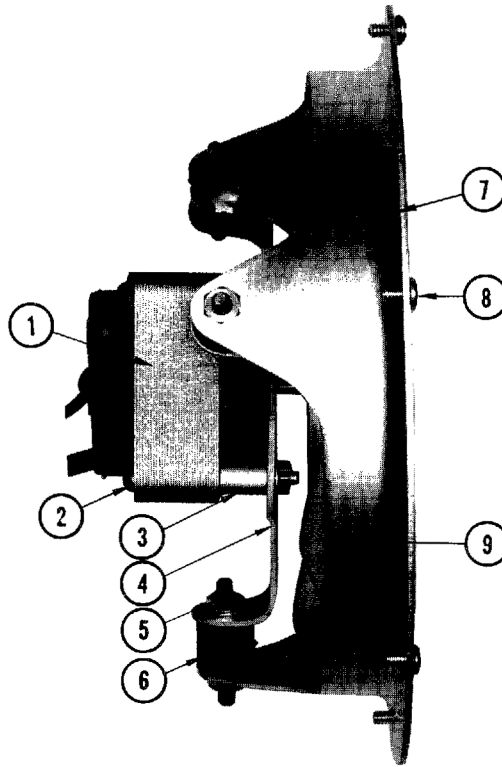

REF. NO.	PART NO.	SERIAL NO.		QTY.	DESCRIPTION
		EFF.	DISC.		
1.	147-022			1	MOTOR, 115 volt, AC, .1567 in. shaft Mounting Hardware: (not included)
2.	212-022			2	SCREW, 8-32 x 1 1/2 in. RHS
	210-008			2	LOCKWASHER, steel, internal #8
	210-409			2	NUT, hex, brass, 8-32 x 5/16 in.
3.	166-006			2	TUBE, spacer, alum. .196 ID x 5/16 OD x 7/16 in. long
4.	426-046			1	MOUNT, fan motor Mounting Hardware: (not included)
5.	210-409			6	NUT, hex, brass, 8-32 x 5/16 in.
	210-008			6	LOCKWASHER, steel, internal #8
6.	348-008			3	SHOCKMOUNT, rubber, solid, 1/2 dia. x 1/2 in. high
7.	354-051			1	RING, fan, alum. 5 3/4 in. ID Mounting Hardware: (not included)
8.	211-507			6	SCREW, 6-32 x 5/16 in. BHS
9.	369-015			1	FAN, alum. 5 1/2 in. clockwise Includes:
	213-007			1	SCREW, set, 10-32 x 1/4 in., HSS

CABINET

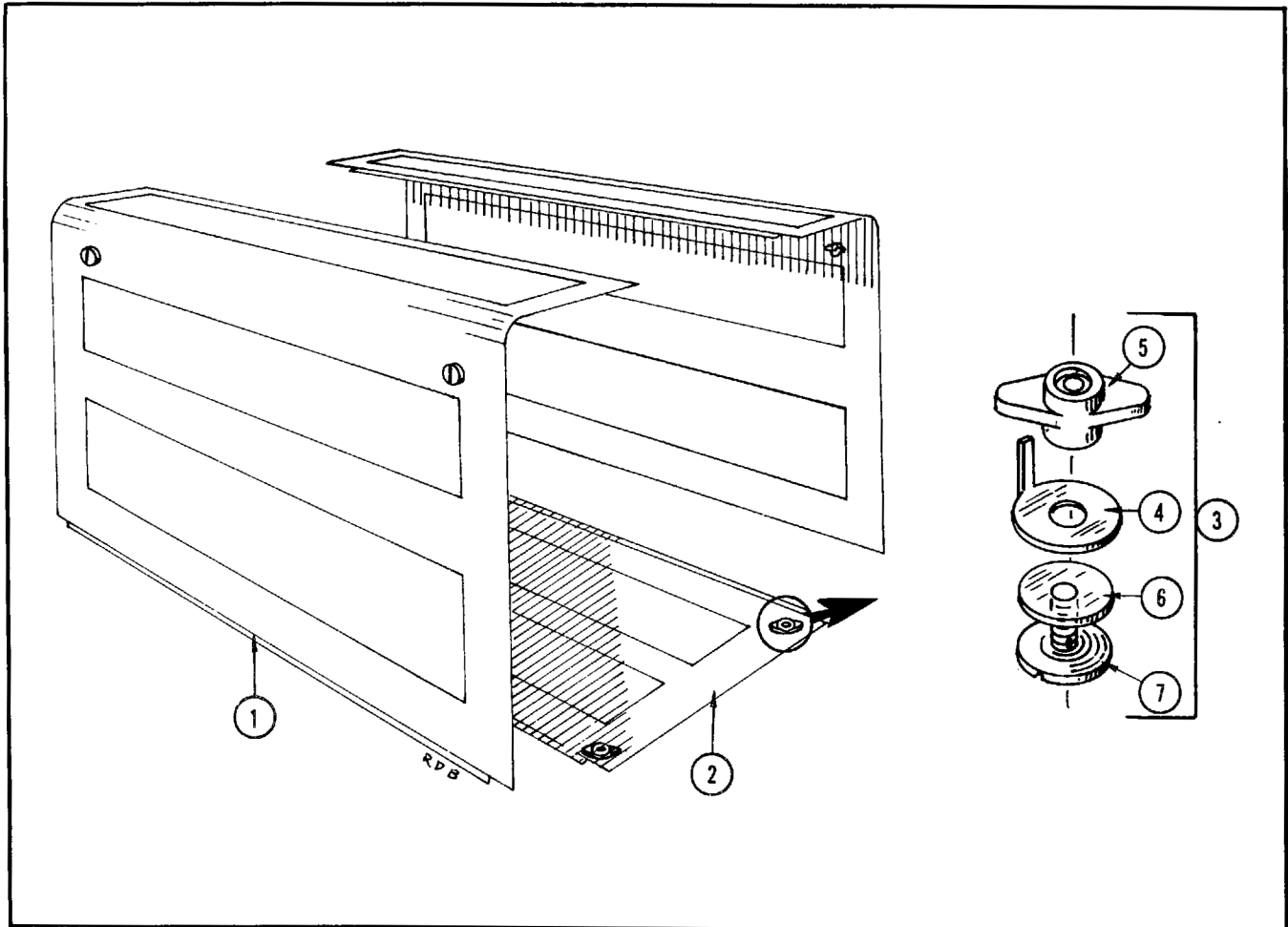

REF. NO.	PART NO.	SERIAL NO.		QTY.	DESCRIPTION
		EFF.	DISC.		
1.	387-479			2	PLATE, cabinet side, alum. $5\frac{25}{32} \times 14\frac{63}{64} \times 20\frac{13}{32}$ in.
2.	387-478			1	PLATE, cabinet bottom, alum. $20.406 \times 10\frac{3}{16} \times \frac{5}{16}$ in.
3.	214-057			8	FASTENER, cabinet latch assembly Consisting of:
4.	105-007			1	STOP, steel, $\frac{7}{32}$ ID x $2\frac{1}{32}$ OD
5.	210-480			1	NUT, latch, nylon, cabinet fastener
6.	210-847			1	WASHER, nylon .164 ID x .500 OD
7.	213-033			1	SCREW, fastening, steel, $\frac{1}{2} \times \frac{1}{2} \times 8-32$ in.

SWITCHES

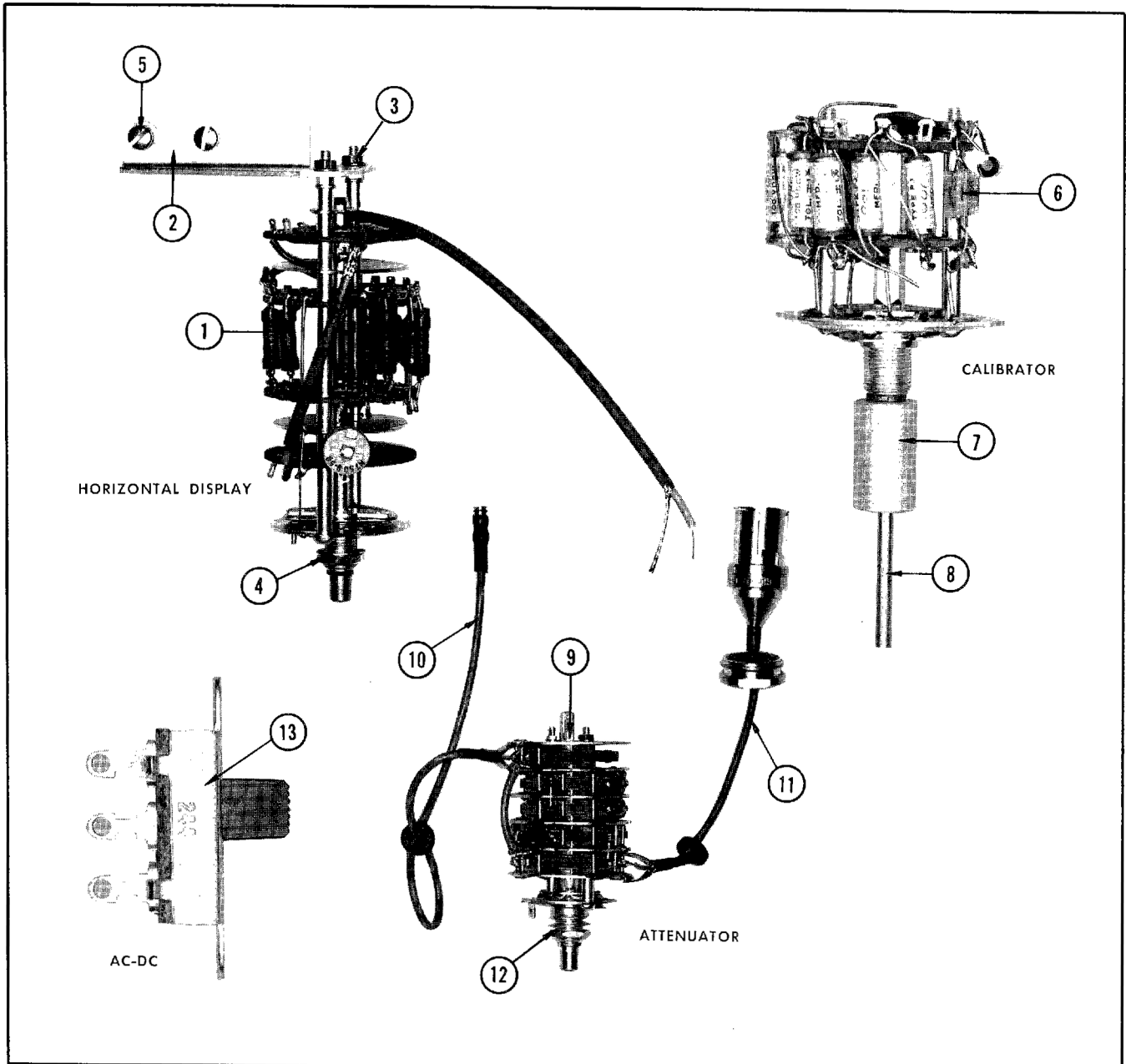

REF. NO.	PART NO	SERIAL NO.		QTY.	DESCRIPTION
		EFF.	DISC.		
1.	262-441			1	SWITCH, HORIZONTAL DISPLAY, wired
	260-414			1	SWITCH, HORIZONTAL DISPLAY, unwired Includes:
2.	406-777			1	BRACKET, alum. 1 ¹⁵ / ₁₆ x 2 ³ / ₄ x ⁵ / ₈ in.
3.	210-006			2	LOCKWASHER, steel, internal #6
	210-449			2	NUT, hex, brass, 5-40 x ¹ / ₄ in. Mounting Hardware: (not included)
4.	210-012			1	LOCKWASHER, steel, pot internal ³ / ₈ x ¹ / ₂ in.
	210-413			1	NUT, hex, brass, ³ / ₈ -32 x ¹ / ₂ in.
	210-840			1	WASHER, steel, .390 ID x ⁹ / ₁₆ OD

SWITCHES (continued)

REF. NO.	PART NO.	SERIAL NO.		QTY.	DESCRIPTION	
		EFF.	DISC.			
5.	210-803			2	WASHER, steel, 6L x 3/8 in.	
	211-507			2	SCREW, 6-32 x 5/16 in. BHS	
6.	262-440			1	SWITCH, CALIBRATOR, wired	
	260-416			1	SWITCH, CALIBRATOR, unwired Mounting Hardware: (not included)	
	210-004			2	LOCKWASHER, steel, internal #4	
	210-406			2	NUT, hex, brass, 4-40 x 3/16 in.	
	211-008			2	SCREW, 4-40 x 1/4 in. BHS	
	376-008			1	COUPLING, alum. 7/8 in. long	
8.	385-161			1	ROD, stainless steel, 1/8 in. dia. x 7 7/8 in. long	
9.	262-464			1	SWITCH, ATTENUATOR, wired	
	260-415			1	SWITCH, ATTENUATOR, unwired Includes:	
10.	175-233			1	CABLE, Output assembly Consisting of:	
	131-155			1	CONNECTOR, coax, miniature	
	166-221			1	TUBE, ferrule, alum. .089 in. dia. x 1/4 in. long	
	166-239			1	TUBE, coax, adapter, .156 OD x 3/4 in.	
	276-525			1	CORE, ferrite, .437 OD x .196 ID x .125 in. thick	
11.	175-232			1	CABLE, Input assembly Consisting of:	
	132-001			1	NUT, coupling	
	132-002			1	SLEEVE, conductor, outer	
	132-007			1	RING, snap	
	132-016			1	NUT, retaining	
	132-026			1	TRANSITION piece, outer	
	132-027			1	TRANSITION piece, inner	
	132-028			1	INSULATOR	
	132-029			1	CONDUCTOR, inner	
	166-221			1	TUBE, ferrule, alum. .089 in. dia. x 1/4 in. long	
	166-239			1	TUBE, coax, adapter, .156 OD x 3/4 in.	
	276-525			1	CORE, ferrite, .437 OD x .196 ID x .125 in. thick Mounting Hardware: (not included)	
	12.	210-012			11	LOCKWASHER, steel, pot 3/8-32 x 1/2 in.
		210-413			1	NUT, hex, brass, 3/8-32 x 1/2 in.
210-840				1	WASHER, steel, .390 ID x 9/16 OD	
13.	260-145			1	SWITCH, SLIDE, with black button, unwired Mounting Hardware: (not included)	
	210-004			2	LOCKWASHER, steel, internal #4	
	210-406			2	NUT, hex, brass, 4-40 x 3/16 in.	

CERAMIC STRIPS

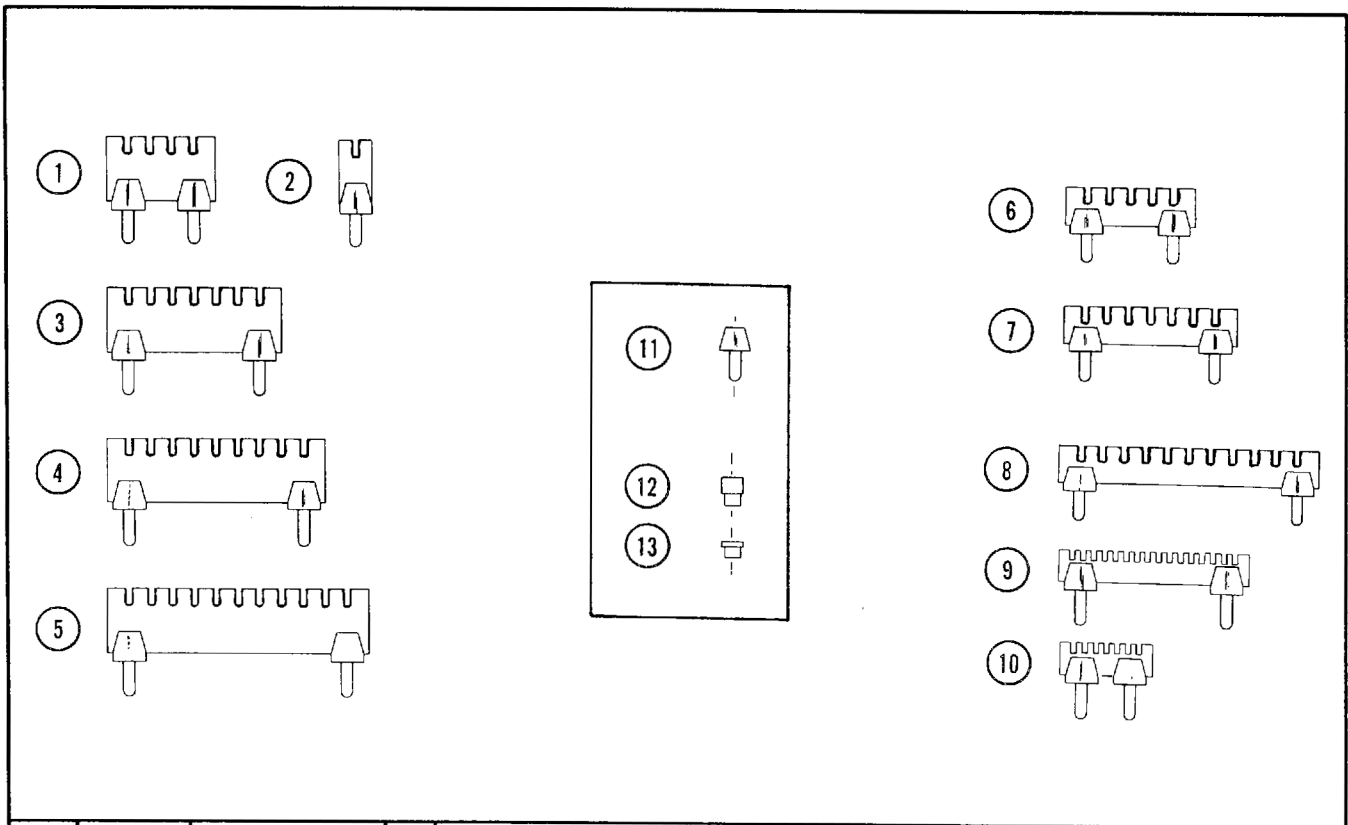

REF. NO.	PART NO.	SERIAL NO.		QTY.	DESCRIPTION
		EFF.	DISC.		
1.	124-088				STRIP, 3/4 in. x 4 notch
2.	124-100				STRIP, 3/4 in. x 1 notch
3.	124-089				STRIP, 3/4 in. x 7 notch
4.	124-090				STRIP, 3/4 in. x 9 notch
5.	124-091				STRIP, 3/4 in. x 11 notch
6.	124-093				STRIP, 7/16 in. x 5 notch
7.	124-094				STRIP, 7/16 in. x 7 notch
8.	124-106				STRIP, 7/16 in. x 11 notch
9.	124-146				STRIP, 7/16 in. x 16 small notch
10.	124-149				STRIP, 7/16 in. x 7 small notch
11.	355-046				STUD, clip, nylon
12.	361-008				SPACER, 1/4 in. high
13.	361-007				SPACER, 5/32 in. high

ACCESSORIES

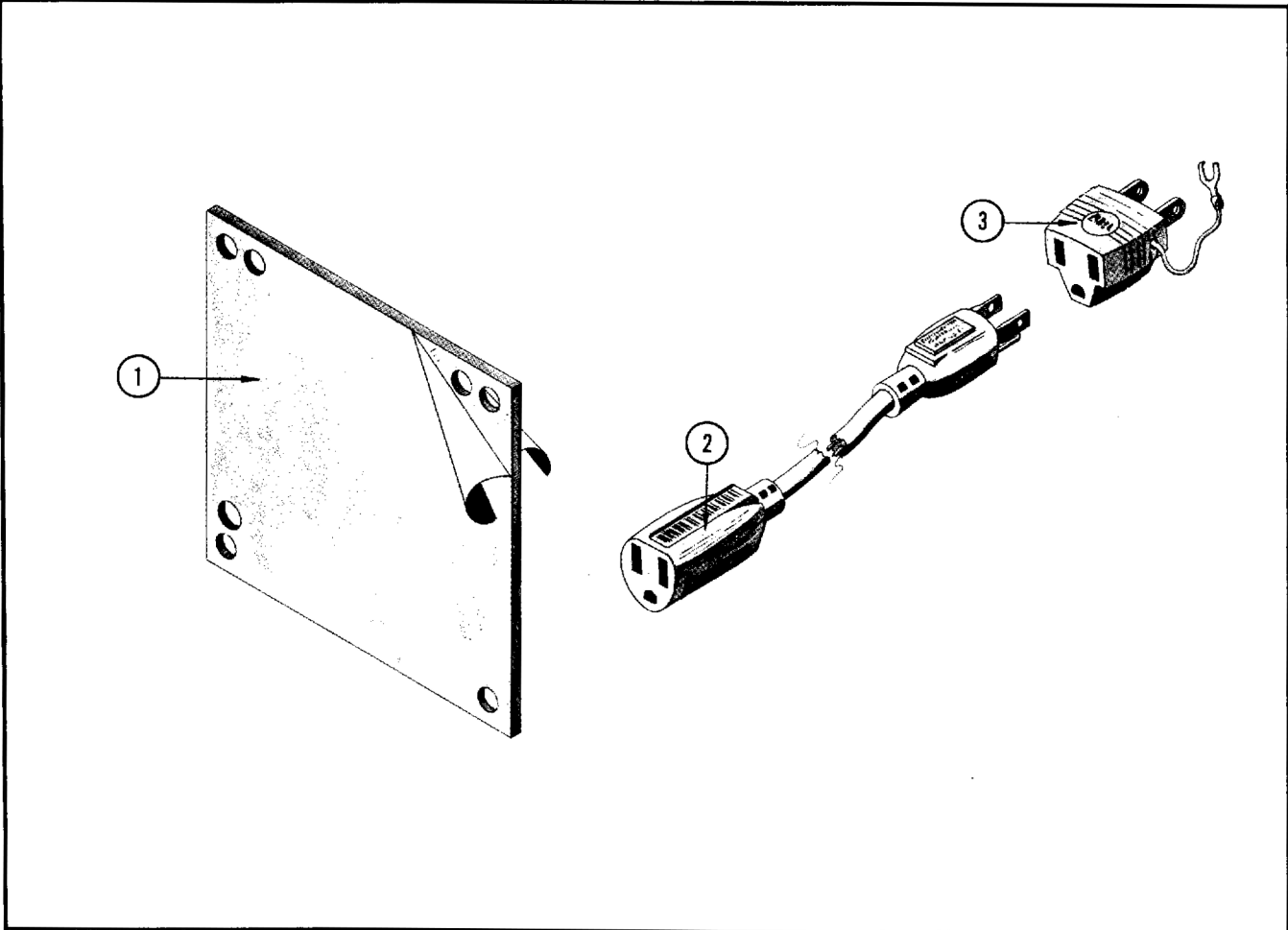

REF. NO.	PART NO.	SERIAL NO.		QTY.	DESCRIPTION
		EFF.	DISC.		
1.	378-514			1	FILTER, light, plexiglas, 5 in. green, with cam hole
2.	161-010			1	CORD, power, 16 gauge, 8 foot
3.	103-013			1	ADAPTER, power cord, 3-wire to 2-wire

ELECTRICAL PARTS

Values are fixed unless marked Variable.

Ckt. No.	Tektronix Part No.	Description	S/N Range
Bulbs			
B388	Use 150-027	Neon, NE-23	
R389	Use 150-027	Neon, NE-23	
R468	Use 150-027	Neon, NE-23	
B369	Use 150-027	Neon, NE-23	
B604	150-001	Incandescent #47 Graticule Light	
B605	150-001	Incandescent #47 Graticule Light	
B627	Use 150-027	Neon, NE-23	
B847	Use 150-027	Neon, NE-23	
B848	Use 150-027	Neon, NE-23	

Capacitors

Tolerance $\pm 20\%$ unless otherwise indicated.

Tolerance of all electrolytic capacitors are as follows (with exceptions):

3 V — 50 V = -10% , $+250\%$

51 V — 350 V = -10% , $+100\%$

351 V — 450 V = -10% , $+ 50\%$

C301	285-576	1 μf	PTM		100 v	10%	
C302	281-022	8-50 pf	Cer.	Var.			
C307	290-099	100 μf	EMT		15 v		
C318	290-121	2 μf	EMC		25 v		101-809
	290-107	25 μf	EMT		25 v		810-up
C336	281-504	10 pf	Cer.		500 v	10%	
C385	281-504	10 pf	Cer.		500 v	10%	
C600A	281-559	1500 pf	Cer.		500 v		
C600B	281-559	1500 pf	Cer.		500 v		
C601	285-588	2 μf	PMC		236 v		
C602	*290-081	2 x 100 μf	EMC		350 v		
C610	281-519	47 pf	Cer.		500 v	10%	
C620	281-504	10 pf	Cer.		500 v	10%	
C627	283-002	.01 μf	Disc Type		500 v		
C636	*290-054	2 x 15 μf	EMC		450 v		101-899
	*290-039	2 x 40 μf	EMC		150 v		900-up
C642	290-160	4000 μf	EMC		50 v		
C644	290-137	100 μf	EMT		30 v		
C646	*290-119	2 x 100 μf	EMC		50 v		
C652	283-003	.01 μf	Disc Type		150 v		
C656	290-015	100 μf	EMT		25 v		
C657	283-024	.1 μf	Disc Type		30 v		X810-up
C662	*290-087	2000 μf	EMC		30 v		
C668	283-024	.1 μf	Disc Type		30 v		
C676	290-015	100 μf	EMT		25 v		
C682	*290-161	2 x 100 μf	EMC		350 v		

Capacitors (Cont'd)

Ckt. No.	Tektronix Part No.	Description	S/N Range
C684	281-504	10 pf Cer.	500 v 10%
C696A,B	Use 290-007	2 x 15 μ f EMC	450 v
C702	Use 290-077	2 x 100 μ f EMC	350 v
C707	281-519	47 pf Cer.	500 v 10%
C716	285-510	.01 μ f PTM	400 v
C720	281-504	10 pf Cer.	500 v 10%
C801	283-006	.02 μ f Disc Type	600 v
C803	285-501	.001 μ f PTM	600 v
C807	285-501	.001 μ f PTM	600 v
C809	Use 283-0619-00	.001 μ f Mica	1500 v
C822	283-036	2500 pf Disc Type	6000 v
C841	283-006	.02 μ f Disc Type	500 v
C842	283-036	2500 pf Disc Type	6000 v
C850	283-006	.02 μ f Disc Type	500 v
C867	285-510	.01 μ f PTM	400 v
C874	283-001	.005 μ f Disc Type	500 v 101-899
	285-527	.1 μ f MPT	600 v 900-up
C878	281-525	470 pf Cer.	500 v
C902	285-595	.1 μ f PTM	100 v 1%
C903	285-595	.1 μ f PTM	100 v 1%
C907	285-596	.01 μ f PTM	100 v 1% 101-1999
	283-593	.01 μ f Mica	100 v 1% 2000-up
C908	285-596	.01 μ f PTM	100 v 1% 101-1999
	283-593	.01 μ f Mica	100 v 1% 2000-up
C912	285-597	.001 μ f PTM	100 v 1% 101-1999
C912	283-594	.001 μ f Mica	100 v 1% 2000-up
C913	285-597	.001 μ f PTM	100 v 1% 101-1999
	283-594	.001 μ f Mica	100 v 1% 2000-up
C916	281-011	5-25 pf Cer.	Var. 101-399
	281-063	9-35 pf Cer.	Var. 400-1999
C916	281-501	4.7 pf Cer	Var. 500 v ± 1 pf 2000-up
C917	281-590	56 pf Cer.	500 v 2% 101-1999X
C918	281-590	56 pf Cer.	500 v 2% 101-1999X
C919	Use 281-505	12 pf (Nominal value) selected	101-1999X
C920	281-013	8-50 pf Cer.	Var. 101-399
C920	281-063	9-35 pf Cer.	Var. 400-1999X
C922	Use 281-519	47 pf Cer.	500 v 10% 101-1999X
C933	283-059	1 μ f Disc Type	25 v X2000-up
C934	281-603	39 pf Cer.	500 v 5% X2000-up
C935	281-562	39 pf Cer.	500 v X2000-up
C936	281-559	1500 pf Cer.	500 v 101-1999
	283-003	.01 μ f Disc Type	150 v 2000-up
C937	290-135	15 μ f EMT	20 v X2000-up
C939	283-004	.02 μ f Disc Type	150 v 101-1999
	283-026	.2 μ f Disc Type	25 v 2000-up

Parts List—Type 661

Capacitors (Cont'd)

Ckt. No.	Tektronix Part No.	Description			S/N Range
C940	281-559	1500 pf	Cer.	500 v	101-1999
	281-598	1000 pf	Cer.		2000-up
C941	283-059	1 μ f	Disc Type	25 v	101-1999X
C942	Use 281-061	5.5-18 pf	Cer.	Var.	X2000-up
C944	283-026	.2 μ f	Disc Type	25 v	X2000-up
C947	283-079	.01 μ f	Disc Type	250 v	X2000-up
C948	281-598	1000 pf	Cer.		X2000-up
C949	283-008	.1 μ f	Disc Type	500 v	X2000-up
C951	281-559	1500 pf	Cer.	500 v	101-1999X
C952	283-059	1 μ f	Disc Type	25 v	101-1999X
C954	281-003	.01 μ f	Disc Type	150 v	101-1999X
C955	281-559	1500 pf	Cer.	500 v	101-1999X
C956	283-003	.01 μ f	Disc Type	150 v	101-1999
	281-509	15 pf	Cer.	500 v	2000-up
C961	281-559	1500 pf	Cer.	500 v	101-1999X
				10%	
C962	283-004	.02 μ f	Disc Type	150 v	101-1999X
C963	281-559	1500 pf	Cer.	500 v	101-1999X
C964	283-026	.2 μ f	Disc Type	25 v	101-1999X
C965	283-057	.1 μ f	Disc Type	200 v	X2000-up
C968	Use 281-061	5.5-18 pf	Cer.	Var.	X2000-up
C971	Use 281-060	2-8 pf	Cer.	Var.	X2000-up
C993	283-010	.05 μ f	Disc Type	50 v	101-361X
C994	290-116	500 μ f	EMT	25 v	X251-up
C996	281-559	1500 pf	Cer.	500 v	101-1999X
C997	281-559	1500 pf	Cer.	500 v	101-1999X
C998	281-559	1500 pf	Cer.	500 v	101-1999X
C999	281-559	1500 pf	Cer.	500 v	101-1999X

Diodes

D312	*152-045	Silicon Selected 1N622A			101-939
D312	Use *152-185	Silicon Replaceable by 1N3605			940-up
D313	*152-045	Silicon Selected 1N622A			101-939
D313	Use *152-185	Silicon Replaceable by 1N3605			940-up
D314	152-016	Zener RT6			
D323	152-008	Germanium T12G			101-2479X
D334	152-016	Zener RT6			
D602A,B,C,D	*152-047	Silicon Replaceable by 1N2862			
D642A,B,C,D	152-035	Silicon 1N1563A (or equal)			
D643	152-022	Zener 1M25Z5			
D644	152-008	Germanium T12G			101-2609
D644	*152-0185-00	Silicon Replaceable by 1N3605			2610-up
D649	152-089	Zener 10M12.6Z5			
D653	152-008	Germanium T12G			
D662A,B,C,D	152-035	Silicon 1N1563A (or equal)			
D672	152-008	Germanium T12G			

Diodes (Cont'd)

Ckt. No.	Tektronix Part No.	Description	S/N Range
D682A,B,C,D	*152-047	Silicon Replaceable by 1N2862	
D702A,B,C,D	*152-047	Silicon Replaceable by 1N2862	
D726	152-068	Zener 1M30Z10	
D879	152-025	Germanium 1N634	
D930	152-141	Zener 1N3605	X2000-up
D942	152-090	Silicon FD613	101-1999X
D952	152-090	Silicon FD613	101-1999X
D958	} *152-152	Tek GaAs (1 pair)	X2000-up
D959			
D992			
Use *050-072			
	152-099	Tunnel TD1081	270-up

Fuses

F601	159-017	4 Amp 3AG Fast-Blo 117 v 50 & 60 Cycle
	159-021	2 Amp 3AG Fast-Blo 234 v 50 & 60 Cycle

Inductors

L901	*114-145	48-52 μ h	Var.	Core 276-536	101-1999
L901	*114-162	49-53 μ h	Var.	Core 276-548	2000-up
L906	Use *114-157	3.5-6 μ h	Var.	Core 276-511	
L911	*114-146	.3-.55 μ h	Var.	Core 276-511	
L912	276-507	Core, Ferramic Suppressor			X2000-up
L916	*108-242	35 nh			101-1999
L916	*114-161	35-52 μ h	Var.	Core 276-506	2000-up
L936	*108-241	.05 μ h			101-1999X
L940	108-249	12 μ h			X2000-up
L948	108-226	100 μ h			X2000-up
L955	*108-206	.15 μ h			X2000-up
L958	*108-088	3.2 μ h			X2000-up
L960	108-240	820 μ h			X2000-up
L970	*108-088	3.2 μ h			X2000-up
L979	276-525	Ferrite Core			X2000-up
L984	276-525	Ferrite Core			
L990	*120-266	Toroid 10T TD63			101-361
L990	*120-202	Toroid 15T TD27			362-up
L992	*108-261	Air Core, 4 Turns #27 Wire on 1/8" Dia			X362-up

Connectors

P950	131-156	Coaxial, 50 Ω , mini	X2000-up
P979	131-156	Coaxial, 50 Ω , mini	X2000-up

Parts List—Type 661

Resistors

Ckt. No.	Tektronix Part No.		Description			S/N Range
Resistors are fixed, composition, $\pm 10\%$ unless otherwise indicated.						
R302	318-012	25 k	$\frac{1}{8}$ w		Prec.	1%
R303	309-182	3 k	$\frac{1}{2}$ w		Prec.	1%
R304	301-823	82 k	$\frac{1}{2}$ w			5%
R305†	311-272	5 k		Var.		VERNIER
R306	301-823	82 k	$\frac{1}{2}$ w			5%
R307	301-392	3.9 k	$\frac{1}{2}$ w			5%
R308	301-392	3.9 k	$\frac{1}{2}$ w			5%
R309	301-822	8.2 k	$\frac{1}{2}$ w			5%
R310†	311-272	5 k		Var.		POSITION
R311A	309-115	1 k	$\frac{1}{2}$ w		Prec.	1%
R311B	309-098	2 k	$\frac{1}{2}$ w		Prec.	1%
R311C	309-159	5 k	$\frac{1}{2}$ w		Prec.	1%
R311D	309-100	10 k	$\frac{1}{2}$ w		Prec.	1%
R311E	309-153	20 k	$\frac{1}{2}$ w		Prec.	1%
R311F	309-280	51.1 k	$\frac{1}{2}$ w		Prec.	1%
R311G	Use 323-387	105 k	$\frac{1}{2}$ w		Prec.	1%
R311H	309-181	2.5 k	$\frac{1}{2}$ w		Prec.	1%
R311J	309-193	25 k	$\frac{1}{2}$ w		Prec.	1%
R311K	309-115	1 k	$\frac{1}{2}$ w		Prec.	1%
R311L	309-036	18 k	$\frac{1}{2}$ w		Prec.	1%
R312	301-473	47 k	$\frac{1}{2}$ w			5%
R312	301-623	62 k	$\frac{1}{2}$ w			5%
R314	301-332	3.3 k	$\frac{1}{2}$ w			5%
R317	301-622	6.2 k	$\frac{1}{2}$ w			5%
R318	302-100	10 Ω	$\frac{1}{2}$ w			101-809
R318	316-101	100 Ω	$\frac{1}{4}$ w			810-up
R319	316-391	390 Ω	$\frac{1}{4}$ w			
R324	302-473	47 k	$\frac{1}{2}$ w			
R335	309-100	10 k	$\frac{1}{2}$ w		Prec.	1%
R337	309-100	10 k	$\frac{1}{2}$ w		Prec.	1%
R338	301-682	6.8 k	$\frac{1}{2}$ w			5%
R341	302-101	100 Ω	$\frac{1}{2}$ w			
R344	301-912	9.1 k	$\frac{1}{2}$ w			5%
R349	301-912	9.1 k	$\frac{1}{2}$ w			5%
R354	301-912	9.1 k	$\frac{1}{2}$ w			5%
R356	304-333	33 k	1 w			
R357	311-026	100 k	2 w	Var.		HORIZ. DC BAL.
R358	309-390	429 k	$\frac{1}{2}$ w		Prec.	1%
	309-101	330 k	$\frac{1}{2}$ w		Prec.	1%
R359	311-106	200 k		Var.		101-309 310-up X310-up

† R305 and R310 furnished as a unit.

Resistors (Cont'd)

Ckt. No.	Tektronix Part No.		Description			S/N Range
R361	302-470	47 Ω	$\frac{1}{2}$ w			
R362	302-470	47 Ω	$\frac{1}{2}$ w			
R363	308-211	12 k	5 w		WW	5%
R364	308-051	4 k	5 w		WW	5%
R367	308-211	12 k	5 w		WW	5%
R376	309-390	429 k	$\frac{1}{2}$ w		Prec.	1%
R377	309-045	100 k	$\frac{1}{2}$ w		Prec.	1%
R378	311-026	100 k	2 w	Var.		HORIZ. TAKEOFF DC LEVEL
R379	309-049	150 k	$\frac{1}{2}$ w		Prec.	1%
R380	311-078	50 k	.1 w	Var.		HORIZ. TAKEOFF GAIN 101-309
	311-115	100 k		Var.		
R381	309-162	250 k	$\frac{1}{2}$ w		Prec.	1%
	309-052	220 k	$\frac{1}{2}$ w		Prec.	1%
R382	304-333	33 k	1 w			310-up
R383	302-101	100 Ω	$\frac{1}{2}$ w			101-309
						310-up
R384	302-224	220 k	$\frac{1}{2}$ w			
R385	302-274	270 k	$\frac{1}{2}$ w			
R386	304-103	10 k	1 w			101-2399
R386	306-153	15 k	2 w			2400-up
R387	304-333	33 k	1 w			101-2399
R387	306-273	27 k	2 w			2400-up
R388	316-154	150 k	$\frac{1}{4}$ w			
R389	316-154	150 k	$\frac{1}{4}$ w			
R390	316-394	390 k	$\frac{1}{4}$ w			X2400-up
R391	302-101	100 Ω	$\frac{1}{2}$ w			
R401	302-101	100 Ω	$\frac{1}{2}$ w			
R404	301-912	9.1 k	$\frac{1}{2}$ w			5%
R409	301-912	9.1 k	$\frac{1}{2}$ w			5%
R414	301-912	9.1 k	$\frac{1}{2}$ w			5%
R441	302-470	47 Ω	$\frac{1}{2}$ w			5%
R444	308-211	12 k	5 w		WW	5%
R449	308-051	4 k	5 w		WW	5%
R451	302-470	47 Ω	$\frac{1}{2}$ w			
R456	308-051	4 k	5 w		WW	5%
R458	308-053	8 k	5 w		WW	5%
R461	302-334	330 k	$\frac{1}{2}$ w			
R462	302-101	100 Ω	$\frac{1}{2}$ w			
R463	302-685	6.8 meg	$\frac{1}{2}$ w			X2400-up
R466	306-104	100 k	2 w			
R467	316-394	390 k	$\frac{1}{4}$ w			X2400-up
R468	316-154	150 k	$\frac{1}{4}$ w			
R469	316-154	150 k	$\frac{1}{4}$ w			
R472	309-390	429 k	$\frac{1}{2}$ w		Prec.	1%
R473		Selected				
R476	304-333	33 k	1 w			101-309X
R477	311-026	100 k	2 w	Var.		VERT. DC BAL.
R600	306-100	10 Ω	2 w			
R601	308-079	117 Ω	5 w		WW	5%
R602	302-104	100 k	$\frac{1}{2}$ w			
R603	302-563	56 k	$\frac{1}{2}$ w			

Parts List—Type 661

Resistors (Cont'd)

Ckt. No.	Tektronix Part No.	Description	S/N Range
R604†	311-275	50 Ω	Var. WW SCALE ILLUM.
R605	308-142	30 Ω	3 w WW 5%
R610	309-261	300 k	1/2 w Prec. 1%
R612	309-045	100 k	1/2 w Prec. 1%
R614	301-624	620 k	1/2 w 5%
R616	302-224	220 k	1/2 w
R617	301-624	620 k	1/2 w 5%
R618	302-105	1 meg	1/2 w
R620	302-105	1 meg	1/2 w
R621	302-105	1 meg	1/2 w
R623	302-471	470 Ω	1/2 w
R626	Use 304-104	100 k	1 w
R628	301-204	200 k	1/2 w 5%
R629	301-513	51 k	1/2 w 5%
R630	302-470	47 Ω	1/2 w
R631	303-510	51 Ω	1 w 5% 101-1219
R631	301-330	33 Ω	1/2 w 5% 1220-up
R632	302-470	47 Ω	1/2 w
R633	303-510	51 Ω	1 w 5% 101-1219
R633	301-330	33 Ω	1/2 w 5% 1220-up
R635	308-091	2 k	5 w WW 5% X2000-up
R640	*308-087	.5 Ω	1 w WW 1%
R641	*308-087	.5 Ω	1 w WW 1% X200-up
R643	301-512	5.1 k	1/2 w 5% 101-2609
R643	301-0202-00	2 k	1/2 w 5% 2610-up
R644	301-101	100 Ω	1/2 w 5% 101-2609
R644	315-0201-00	200 Ω	1/4 w 5% 2610-up
R645	301-304	300 k	1/2 w 5%
R646	Use 304-154	150 k	1 w 5%
R647	Use 308-012	40 Ω	10 w WW 5%
R648	*310-537	2.47 Ω	8 w Mica Plate 1%
R649	308-012	40 Ω	10 w WW 5% 101-2609
R649	308-0153-00	100 Ω	10 w WW 5% 2610-up
R650	309-098	2 k	1/2 w
R651	311-158	200 Ω	Var. Prec. 1% -19 VOLTS
R652	309-098	2 k	1/2 w Prec. 1%
R653	302-472	4.7 k	1/2 w
R653	316-472	4.7 k	1/4 w 101-809 810-up
R654	301-513	51 k	1/2 w 5%
R655	301-273	27 k	1/2 w 5%
R656	308-179	5 Ω	5 w WW 5%
R657	316-102	1 k	1/4 w
R659	308-0174-00	117 Ω	8 w WW 5% X810-up X2610-up
R660	*308-087	.5 Ω	1 w WW 1%
R664	310-087	120 k	1 w
R665	310-087	120 k	1 w
R666	311-155	1 k	Var. Prec. 1% +19 VOLTS
R668	309-105	4.21 k	1/2 w Prec. 1%
R669	301-243	24 k	1/2 w 5%

† R604 and SW604 are ganged. Furnished as a unit.

Resistors (Cont'd)

Ckt. No.	Tektronix Part No.		Description			S/N Range
R671	305-823	82 k	2 w		5%	
R673	301-243	24 k	1/2 w		5%	
R674	301-123	12 k	1/2 w		5%	
R675	308-179	5 Ω	5 w		5%	
R676	308-179	5 Ω	5 w	WW	5%	X717-up
R680	304-100	10 Ω	1 w			
R681	304-100	10 Ω	1 w			
R682	302-104	100 k	1/2 w			
R684	309-045	100 k	1/2 w	Prec.	1%	101-899
	309-044	95 k	1/2 w	Prec.	1%	900-up
R685	309-044	95 k	1/2 w	Prec.	1%	
R686	311-017	10 k	.1 w	Var.	100 v ADJ.	X900-up
R693	302-104	100 k	1/2 w			
R694		Selected				
R695	302-470	47 Ω	1/2 w			
R699	302-103	10 k	1/2 w			
R700	306-100	10 Ω	2 w			
R702	301-204	200 k	1/2 w		5%	
R704	302-335	3.3 meg	1/2 w			
R705	301-824	820 k	1/2 w		5%	
R706		Selected				
R707	309-125	300 k	1/2 w	Prec.	1%	
R708	309-161	106 k	1/2 w	Prec.	1%	
R710	301-244	240 k	1/2 w		5%	
R711	302-105	1 meg	1/2 w			
R712	309-243	193 k	1/2 w	Prec.	1%	
R713	301-244	240 k	1/2 w		5%	
R716	302-224	220 k	1/2 w			
R717	309-045	100 k	1/2 w	Prec.	1%	
R718	311-016	10 k	2 w	Var.	+300 VOLTS	
R719	305-473	47 k	2 w		5%	
R720	301-105	1 meg	1/2 w		5%	
R721	301-514	510 k	1/2 w		5%	
R723	302-471	470 Ω	1/2 w			
R726	308-112	6 k	5 w	WW	1%	
R727	302-104	100 k	1/2 w			
R730	302-470	47 Ω	1/2 w			
R731	303-510	51 Ω	1 w		5%	
R732	302-470	47 Ω	1/2 w			
R733	303-510	51 Ω	1 w		5%	
R737	308-176	4 k	20 w	WW	5%	
R801	306-681	680 Ω	2 w			
R803	306-473	47 k	2 w			
R804	302-101	100 Ω	1/2 w			
R806	302-104	100 k	1/2 w			

Parts List—Type 661

Resistors (Cont'd)

Ckt. No.	Tektronix Part No.		Description			S/N Range
R807	301-472	4.7 k	1/2 w			5%
R814	302-102	1 k	1/2 w			
R815	302-474	470 k	1/2 w			
R817	302-101	100 Ω	1/2 w			
R840	Use 306-395	3.9 meg	2 w			
R841	311-042	2 meg	2 w	Var.		HIGH VOLTAGE
R842	306-126	12 meg	2 w			
R843	306-126	12 meg	2 w			
R845	311-121	5 meg		Var.		FOCUS
R846	306-565	5.6 meg	2 w			
R847	302-684	680 k	1/2 w			
R848	311-043	2 meg		Var.		INTENSITY
R849	302-103	10 k	1/2 w			
R862	302-224	220 k	1/2 w			
R863	302-104	100 k	1/2 w			
R864	311-276	250 k		Var.	WW	ASTIGMATISM
R865	303-223	22 k	1 w			5%
R866	311-191	10 k		Var.		BLANK BAL.
R867	303-303	30 k	1 w			5%
R871	308-211	12 k	5 w		WW	5%
R873	302-102	1 k	1/2 w			
R874	308-053	8 k	5 w		WW	5%
R875	316-101	100 Ω	1/4 w			X900-up
R876	316-221	220 Ω	1/4 w			
R877	301-392	39 k	1/2 w			5%
R878	301-152	1.5 k	1/2 w			5%
R879	301-392	3.9 k	1/2 w			5%
R904	311-056	500 Ω	.1 w	Var.		(100 KC) CAL. AMPL. 101-1999
	316-100	10 Ω	1/4 w			2000-up
R909	311-056	500 Ω	.1 w	Var.		(1 MC) CAL. AMPL. 101-1999
R909	316-100	10 Ω	1/4 w			2000-up
R912	316-390	39 Ω	1/4 w			X2000-up
R914	311-056	500 Ω	.1 w	Var.		(10 MC) CAL. AMPL. 101-1999X
R919	316-103	10 k	1/4 w			X2000-up
R927	315-100	10 Ω	1/4 w			5% 101-1999X
R929	315-100	10 Ω	1/4 w			5% 101-1999X
R933	315-100	10 Ω	1/4 w			5% 101-1999
	315-471	470 Ω	1/4 w			5% 2000-up
R934	315-100	10 Ω	1/4 w			5% 101-1999
	315-471	470 Ω	1/4 w			5% 2000-up
R935	315-100	10 Ω	1/4 w			101-1999
	301-181	180 Ω	1/2 w			5% 2000-up
R939	302-221	220 Ω	1/2 w			101-1999X
R942	311-433	100 Ω		Var.		OSC. FEEDBACK
R945	308-062	3 k	5 w		WW	5% X2000-up

Resistors (Cont'd)

Ckt. No.	Tektronix Part No.		Description			S/N Range
R947	316-101	100 Ω	$\frac{1}{4}$ w			X2000-up
R951	315-101	100 Ω	$\frac{1}{4}$ w		5%	X2000-up
R952	315-512	5.1 k	$\frac{1}{4}$ w		5%	101-1999
	315-101	100 Ω	$\frac{1}{4}$ w		5%	2000-up
R954	315-100	10 Ω	$\frac{1}{4}$ w		5%	101-1999
R954	315-272	2.7 k	$\frac{1}{4}$ w		5%	2000-up
R955	315-101	100 Ω	$\frac{1}{4}$ w		5%	X2000-up
R957	Use 318-106	4.75 k	$\frac{1}{8}$ w		Prec. 1%	101-1999X
R958	318-073	5.88 k	$\frac{1}{8}$ w		Prec. 1%	101-1999X
R959	311-074	5 k	.1 w	Var.		AMPL. LIMIT 101-1999X
R960	308-172	3.5 k	5 w		WW	5% 101-1999
	315-101	100 Ω	$\frac{1}{4}$ w			5% 2000-up
R962	302-101	100 Ω	$\frac{1}{2}$ w			101-1999
	311-433	100 Ω		Var.		2000-up
R964	308-288	2.15 k	5 w		WW	5% X2000-up
R965	311-434	500 Ω		Var.	WW	OUTPUT AMPL X2000-up
R966	318-034	2 k			Prec.	1% 101-1999X
R967	318-090	104 Ω	$\frac{1}{8}$ w		Prec.	1% 101-1999
	311-097	200 Ω	.5 w	Var.		2000-up
R968	318-090	104 Ω	$\frac{1}{8}$ w		Prec.	1% 101-1999
R968	316-560	56 Ω	$\frac{1}{4}$ w			2000-up
R970	315-471	470 Ω	$\frac{1}{4}$ w			5% X2000-up
R976	318-083	200 Ω	$\frac{1}{8}$ w		Prec.	1% 101-1999X
R977	318-091	120 Ω	$\frac{1}{8}$ w		Prec.	1% 101-1999X
R978	318-091	120 Ω	$\frac{1}{8}$ w		Prec.	1% 101-1999
R978	321-636	100 Ω	$\frac{1}{8}$ w		Prec.	$\frac{1}{2}$ % 2000-up
R979	321-636	100 Ω	$\frac{1}{8}$ w		Prec.	$\frac{1}{2}$ % X2000-up
R981A	318-092	40.9 Ω	$\frac{1}{8}$ w		Prec.	$\frac{1}{2}$ %
R981B	318-092	40.9 Ω	$\frac{1}{8}$ w		Prec.	$\frac{1}{2}$ %
R981C	318-093	20.2 Ω	$\frac{1}{8}$ w		Prec.	$\frac{1}{2}$ %
R981D	318-093	20.2 Ω	$\frac{1}{8}$ w		Prec.	$\frac{1}{2}$ %
R982A	318-092	40.9 Ω	$\frac{1}{8}$ w		Prec.	$\frac{1}{2}$ %
R982B	318-092	40.9 Ω	$\frac{1}{8}$ w		Prec.	$\frac{1}{2}$ %
R982C	318-093	20.2 Ω	$\frac{1}{8}$ w		Prec.	$\frac{1}{2}$ %
R982D	318-093	20.2 Ω	$\frac{1}{8}$ w		Prec.	$\frac{1}{2}$ %
R983A	318-092	40.9 Ω	$\frac{1}{8}$ w		Prec.	$\frac{1}{2}$ %
R983B	318-092	40.9 Ω	$\frac{1}{8}$ w		Prec.	$\frac{1}{2}$ %
R983C	318-093	20.2 Ω	$\frac{1}{8}$ w		Prec.	$\frac{1}{2}$ %
R983D	318-093	20.2 Ω	$\frac{1}{8}$ w		Prec.	$\frac{1}{2}$ %
R990	311-001	10 Ω		Var.	WW	DELAYED PULSE GEN. BIAS
	311-258	100 Ω		Var.		101-361 362-up
R991	315-100	10 Ω	$\frac{1}{4}$ w			5% X362-up
R992	301-150	15 Ω	$\frac{1}{2}$ w			5% 101-361
	317-150	15 Ω	$\frac{1}{10}$ w			5% 362-up
R993	316-100	10 Ω	$\frac{1}{4}$ w			101-361
	317-150	15 Ω	$\frac{1}{10}$ w			5% 362-up
R994	315-101	100 Ω	$\frac{1}{4}$ w			5% X362-up

Parts List—Type 661

Relays

Ckt. No.	Tektronix Part No.		Description	S/N Range
K600	148-006		45 sec. Thermal Delay, 26 v.	
K601	148-012	150 Ω	18-v DC	

Switches

	Unwired	Wired			S/N Range
SW301	260-145		Slide	AC DC	
SW311	260-414	*262-441	Rotary	HORIZONTAL DISPLAY	
SW604†	311-275				
SW910	260-416	*262-440	Rotary	μSEC/CYCLE	101-1999
SW910	260-585	*262-636	Rotary	μSEC/CYCLE	2000-up
SW980	260-415	*262-464	Rotary	MV AMPLITUDE	
TK601	Use 260-120		Thermal Cutout 137° ±5° F.		

Transformers

T600	Use *120-164	Toroid 3T TD#12		
T601	*120-267	Low Voltage		
T801	*120-268	High Voltage		
T992	276-535	Ferrite Core		X362-up
T996	*120-193	Toroid 7T TD#26		101-1999X
T998	*120-193	Toroid 7T TD#26		101-1999X

Transistors

Q313	151-035	2N1592		101-939
Q313	*151-103	Replaceable by 2N2219		940-up
Q324	151-015	2N1516/OC170		101-2479
Q324	*151-133	Selected from 2N3251		2480-up
Q333	151-015	2N1516/OC170		
Q344	151-015	2N1516/OC170		
Q354	151-015	2N1516/OC170		
Q404	151-015	2N1516/OC170		
Q414	151-015	2N1516/OC170		
Q644	Use *151-103	Replaceable by 2N2219		
Q647	151-002	2N277		
Q653	151-036	2N601		
Q654	151-064	2N650		
Q657	151-002	2N277		
Q673	151-036	2N601		
Q674	151-064	2N650		
Q677	151-002	2N277		
Q953	151-040	2N1302		101-1999X
Q930	*151-103	Replaceable by 2N2219		X2000-up

†SW604 and R604 are ganged. Furnished as a unit.

Electron Tubes

Ckt. No.	Tektronix Part No.	Description	S/N Range
V364	154-187	6BL8	
V384	154-278	6DJ8	
V454	154-187	6DJ8	
V616	154-043	12AX7	
V624	154-040	12AU6	
V637	154-056	6080	
V694	154-040	12AU6	
V697	154-307	7233	
V716	154-043	12AX7	
V719	*157-067	OG3 checked	
V724	154-040	12AU6	
V737	154-056	6080	
V800	154-167	6CZ5	
V814	154-041	12AU7	
V822	154-051	5642	
V859†	*154-265	T5030-2 CRT Standard Phosphor	100-309
V859	*154-265	T5030-2 CRT Standard Phosphor	310-up
V874	154-187	6DJ8	
V930	154-340	7119	101-1999X

†S/N 101-309 add *050-071 kit.

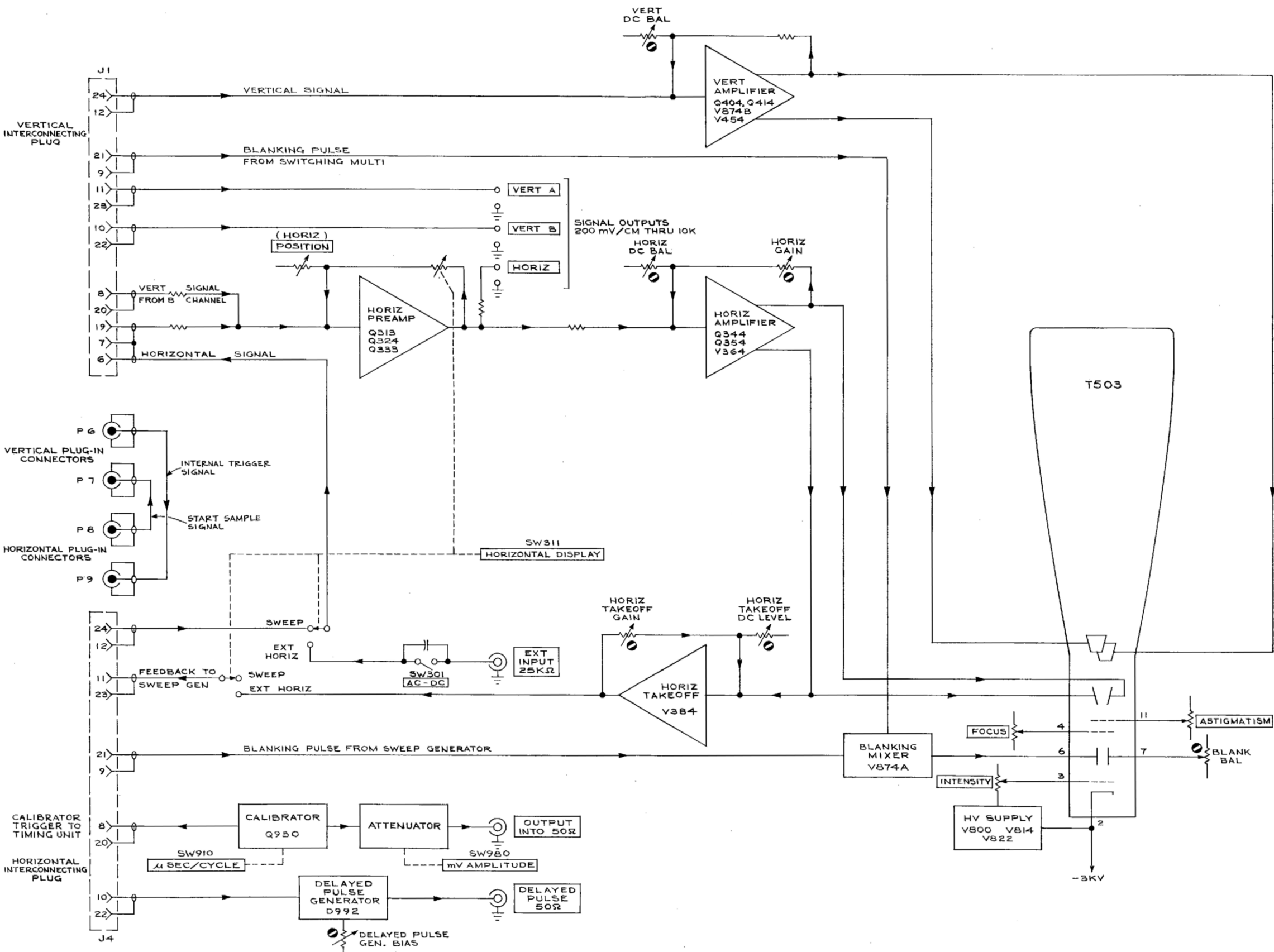

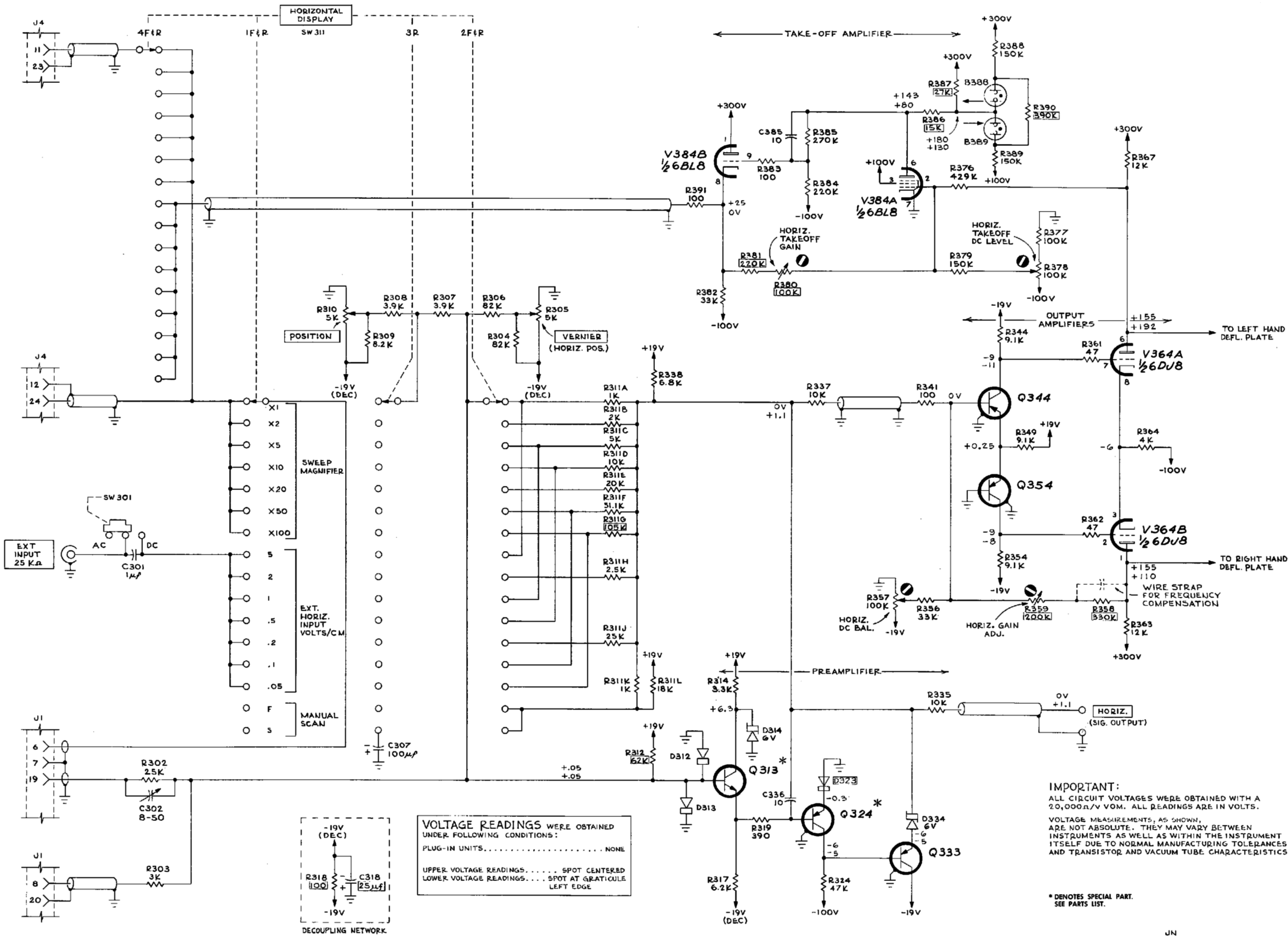

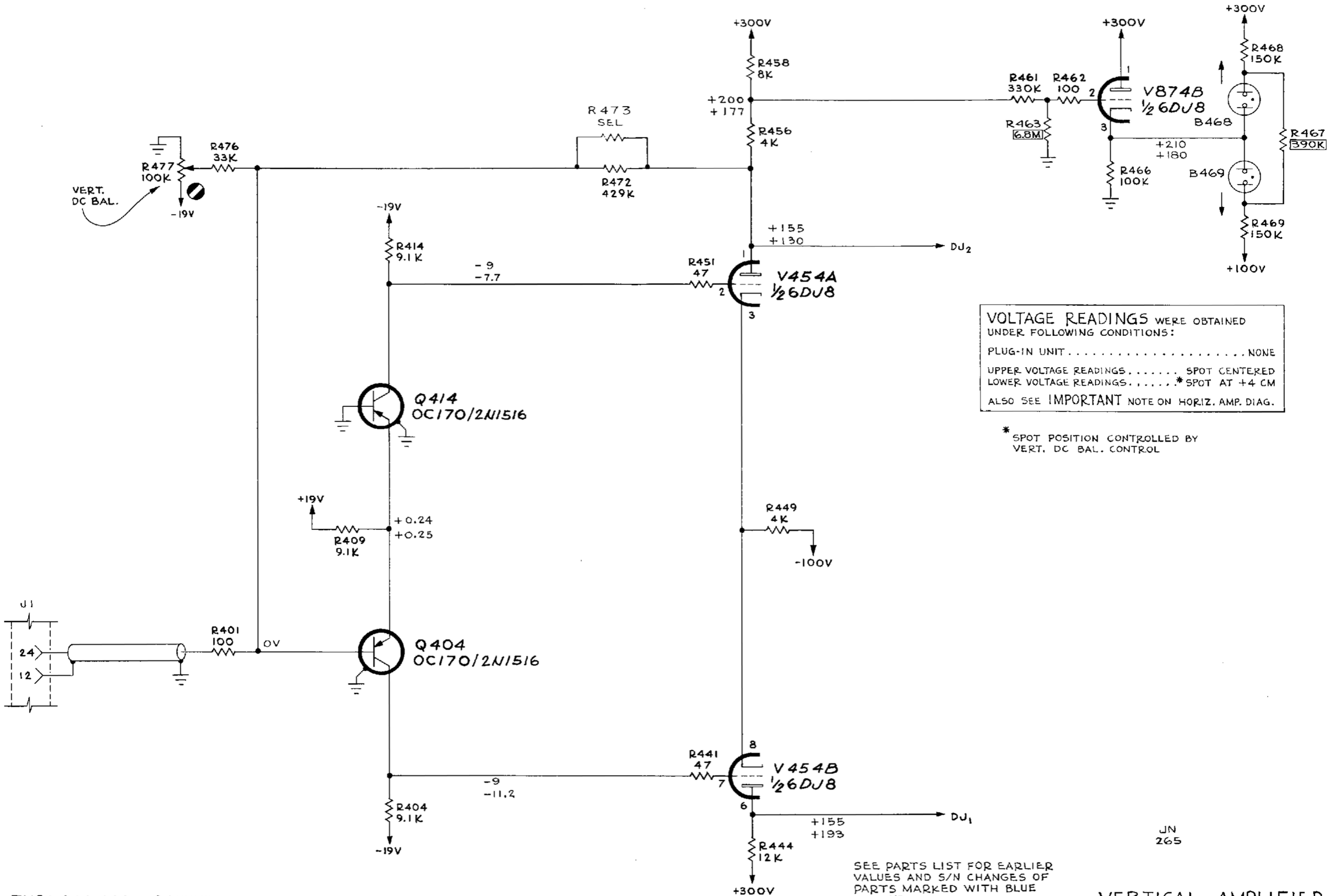

VOLTAGE READINGS WERE OBTAINED UNDER FOLLOWING CONDITIONS:
 PLUG-IN UNIT..... NONE
 UPPER VOLTAGE READINGS..... SPOT CENTERED
 LOWER VOLTAGE READINGS..... * SPOT AT +4 CM
 ALSO SEE IMPORTANT NOTE ON HORIZ. AMP. DIAG.

* SPOT POSITION CONTROLLED BY VERT. DC BAL. CONTROL

SEE PARTS LIST FOR EARLIER VALUES AND S/N CHANGES OF PARTS MARKED WITH BLUE OUTLINE

JN 265

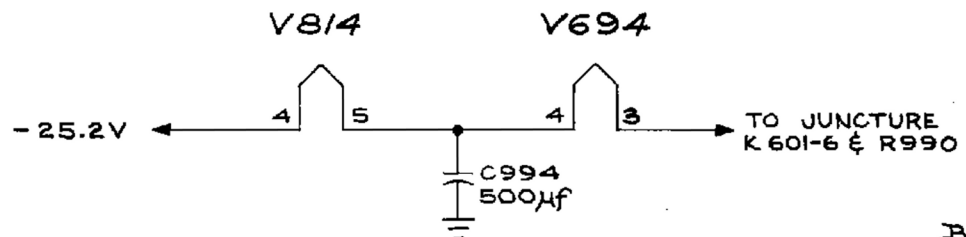
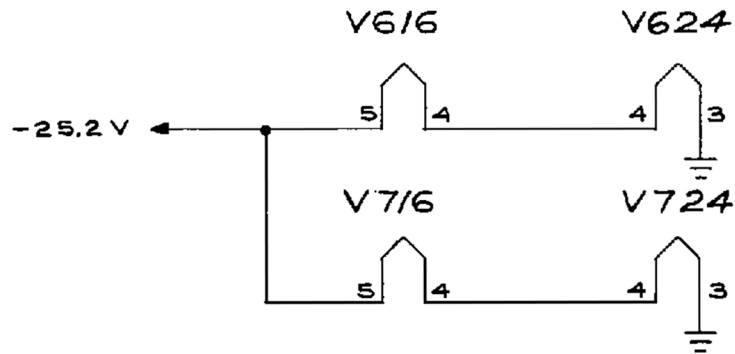
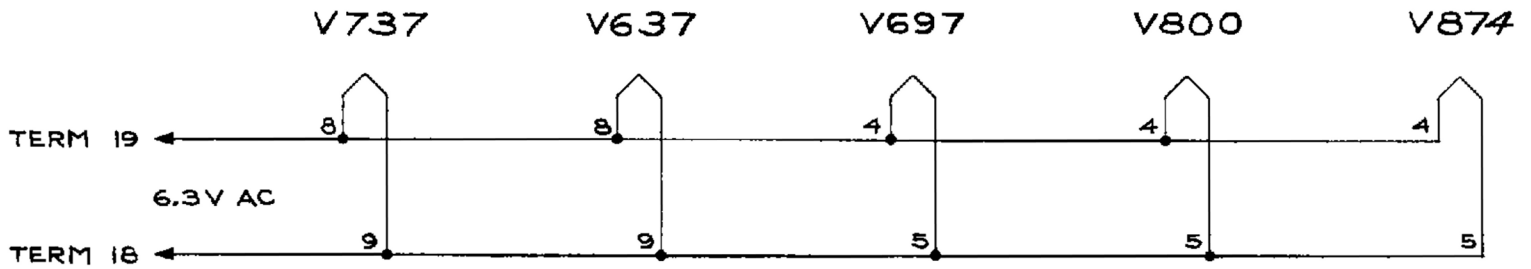
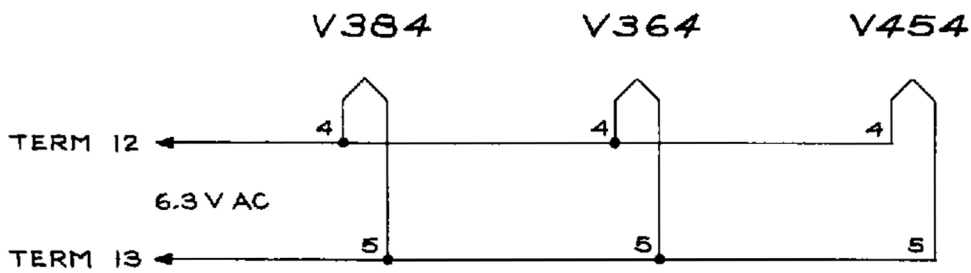

TYPE 661 OSCILLOSCOPE

1265
HEATER WIRING

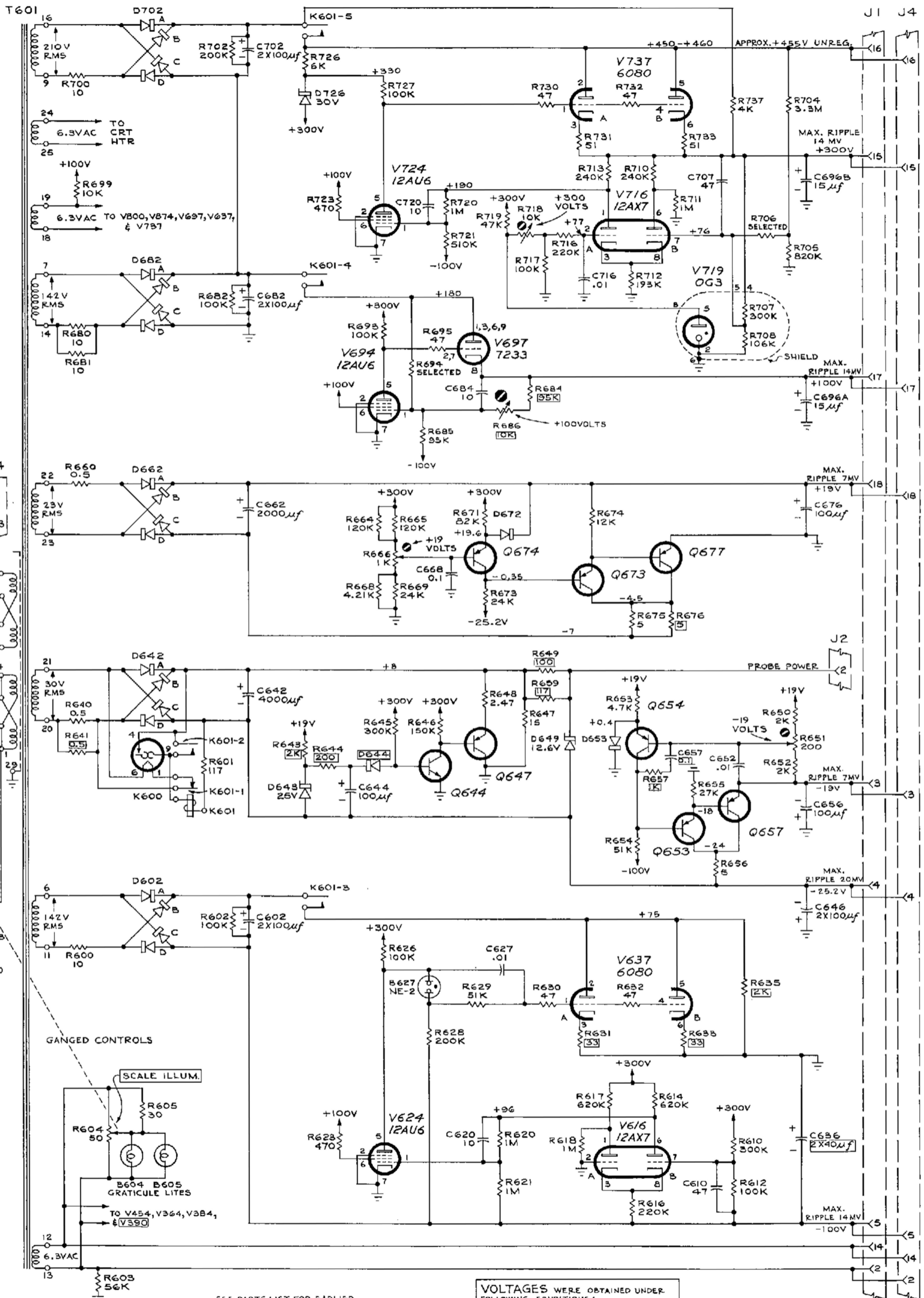

SEE PARTS LIST FOR EARLIER VALUES AND S/N CHANGES OF PARTS MARKED WITH BLUE OUTLINE

SEE PARTS LIST FOR SEMICONDUCTOR TYPES

VOLTAGES WERE OBTAINED UNDER FOLLOWING CONDITIONS:
 PLUG-IN UNITS.....TYPE 451 & TYPE 5T1
 SWEEP.....NONE
 CALIBRATOR.....OFF
 ALSO SEE IMPORTANT NOTE ON HORIZ. AMP DIAG.

MRH 865
POWER SUPPLY

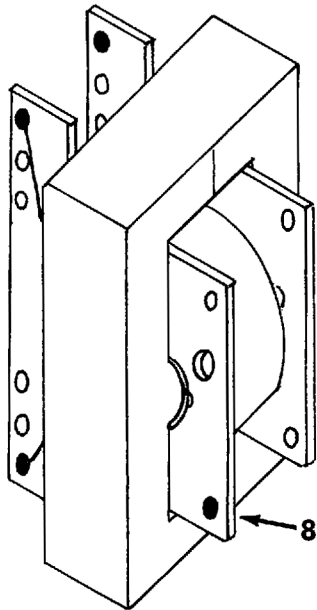
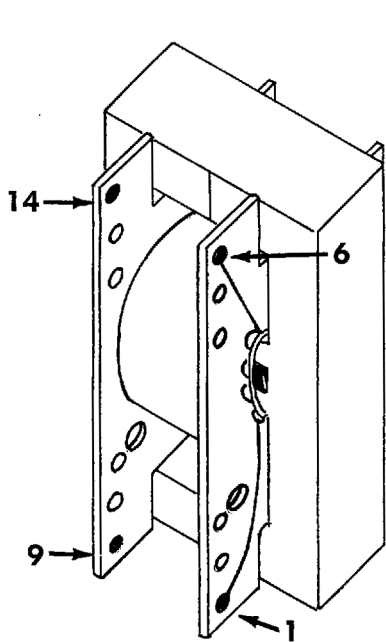

T801 TRANSFORMER DETAILS

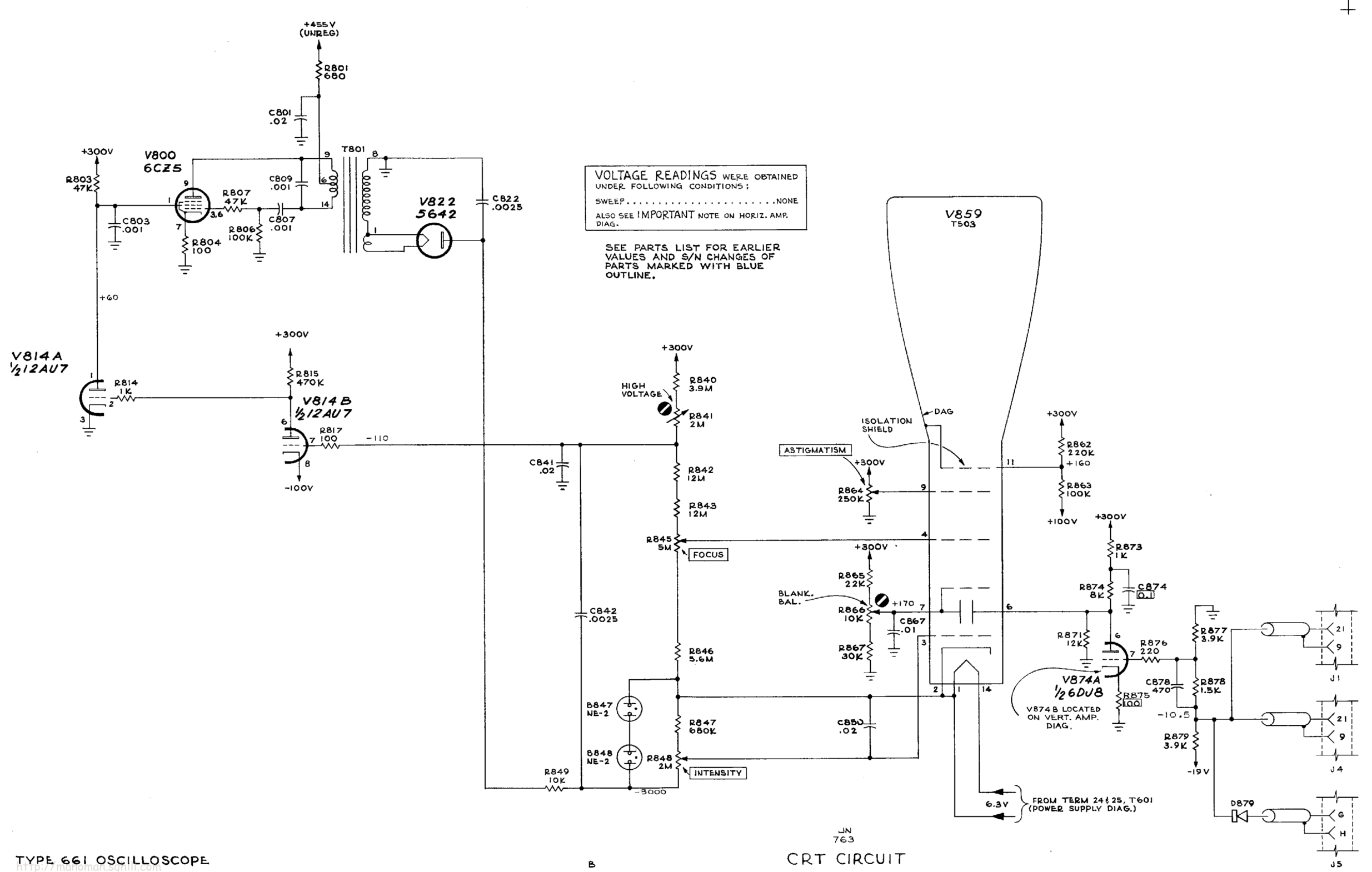

VOLTAGE READINGS WERE OBTAINED UNDER FOLLOWING CONDITIONS;
 SWEEP.....NONE
 ALSO SEE IMPORTANT NOTE ON HORIZ. AMP. DIAG.

SEE PARTS LIST FOR EARLIER VALUES AND S/N CHANGES OF PARTS MARKED WITH BLUE OUTLINE.

V874A
 1/2 6DU8
 V874B LOCATED ON VERT. AMP. DIAG.

JN 763
 CRT CIRCUIT

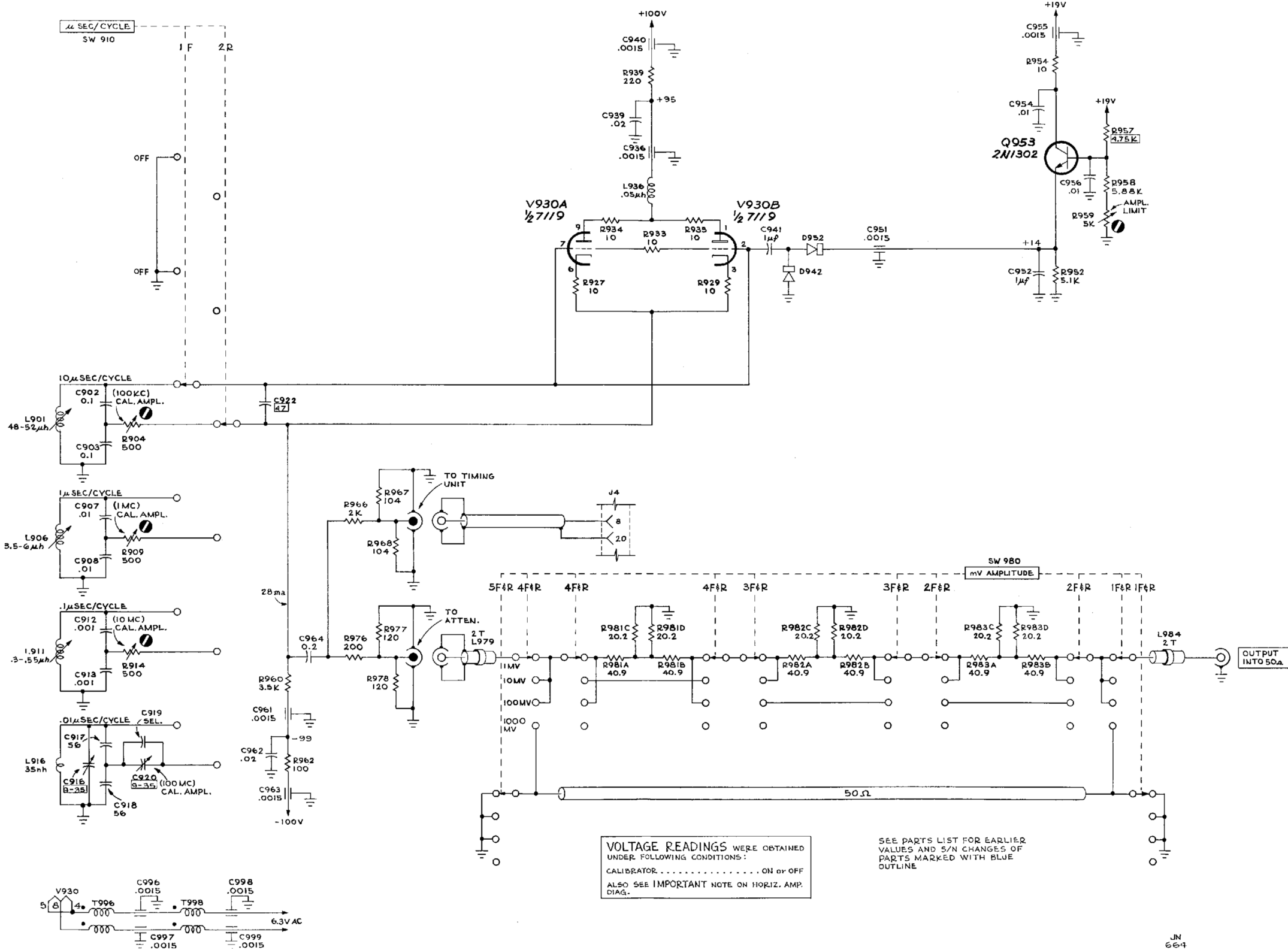

VOLTAGE READINGS WERE OBTAINED UNDER FOLLOWING CONDITIONS:
CALIBRATOR ON or OFF
ALSO SEE IMPORTANT NOTE ON HORIZ. AMP. DIAG.

SEE PARTS LIST FOR EARLIER VALUES AND S/N CHANGES OF PARTS MARKED WITH BLUE OUTLINE

+

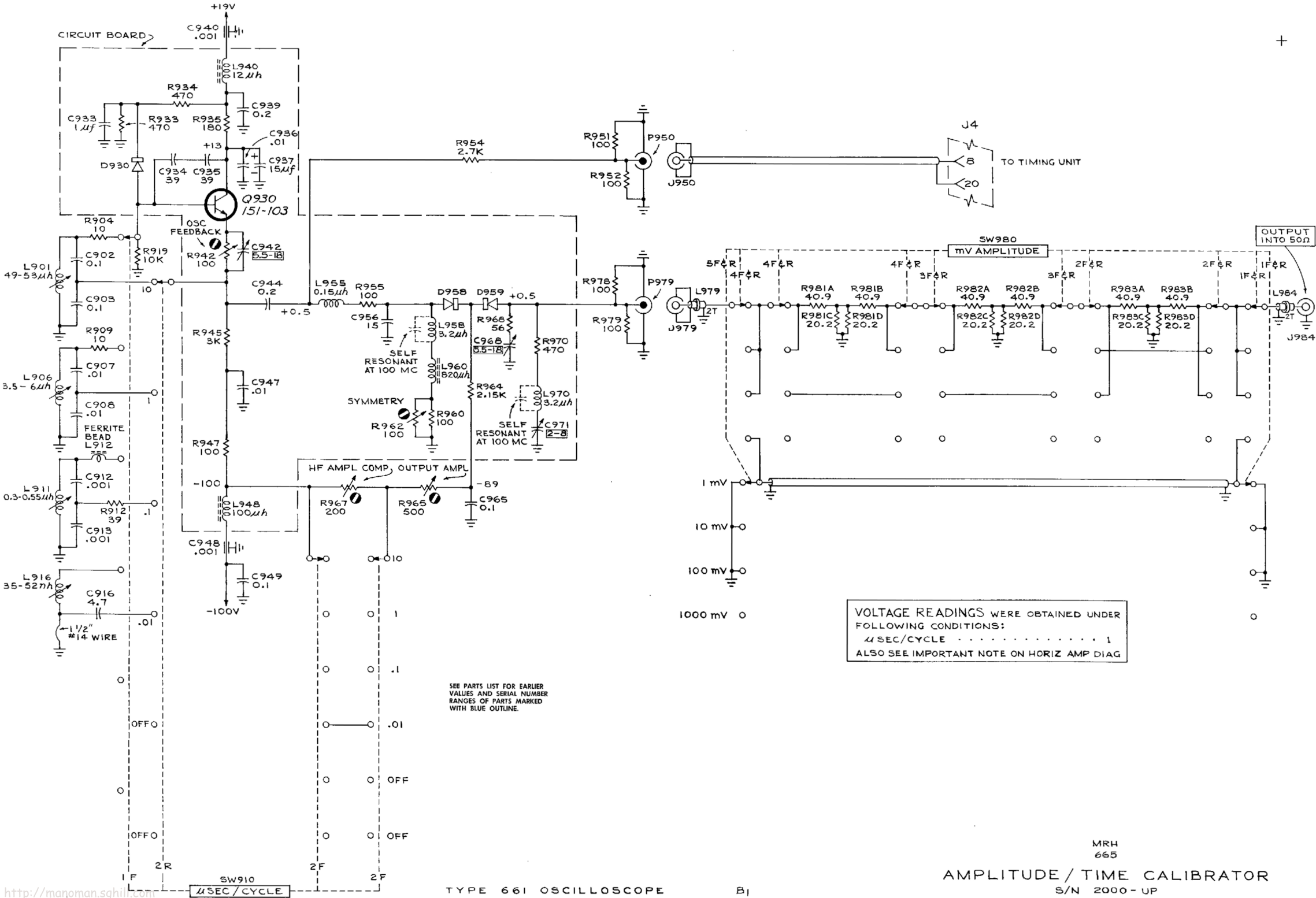

SEE PARTS LIST FOR EARLIER VALUES AND SERIAL NUMBER RANGES OF PARTS MARKED WITH BLUE OUTLINE.

MRH
665
AMPLITUDE/TIME CALIBRATOR
S/N 2000-UP

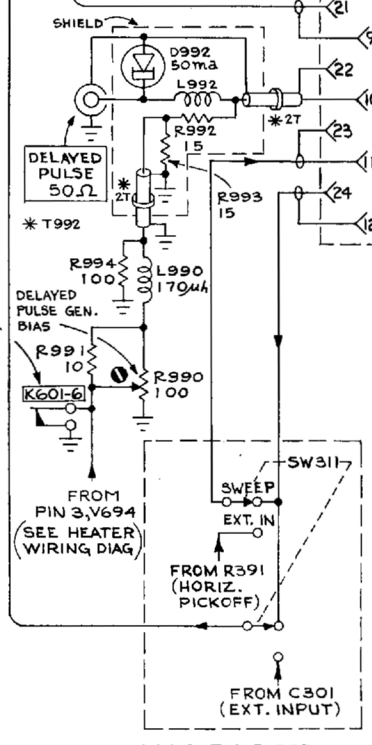
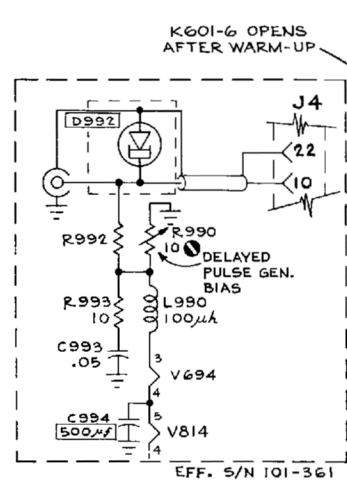
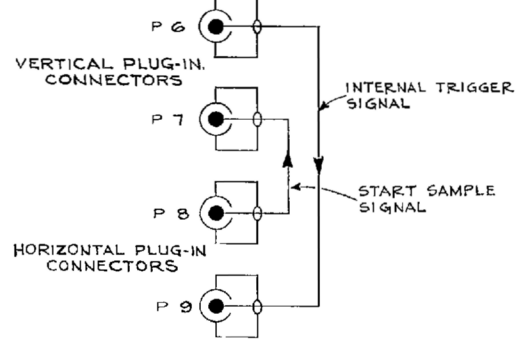
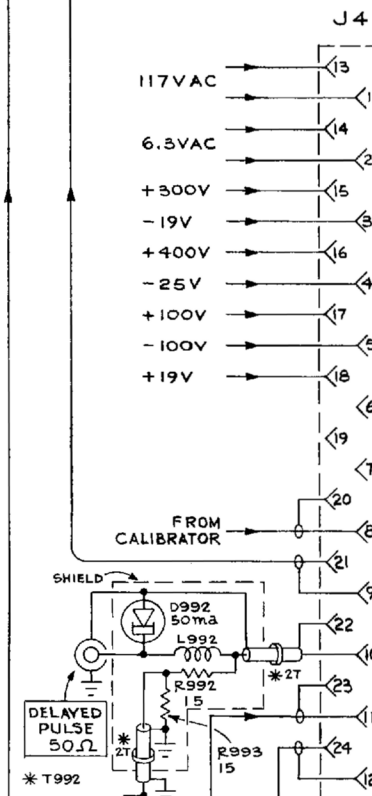
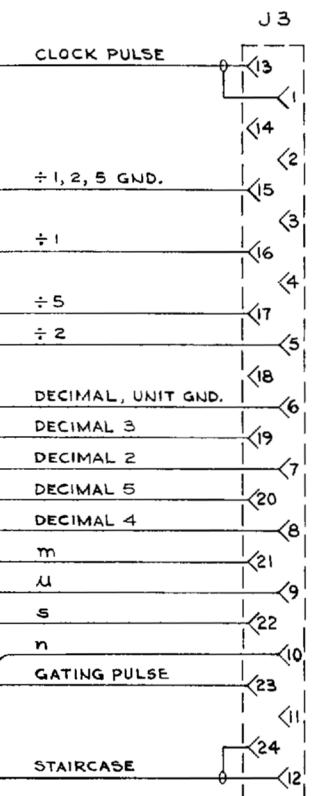
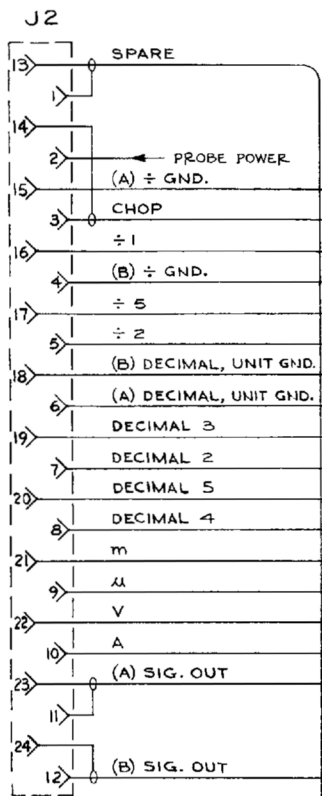
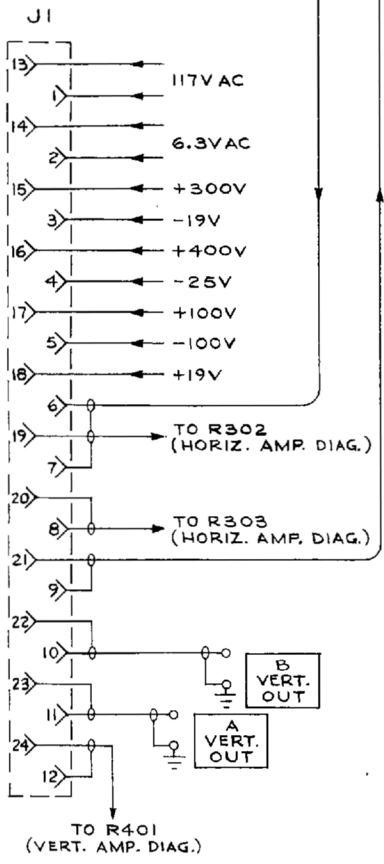
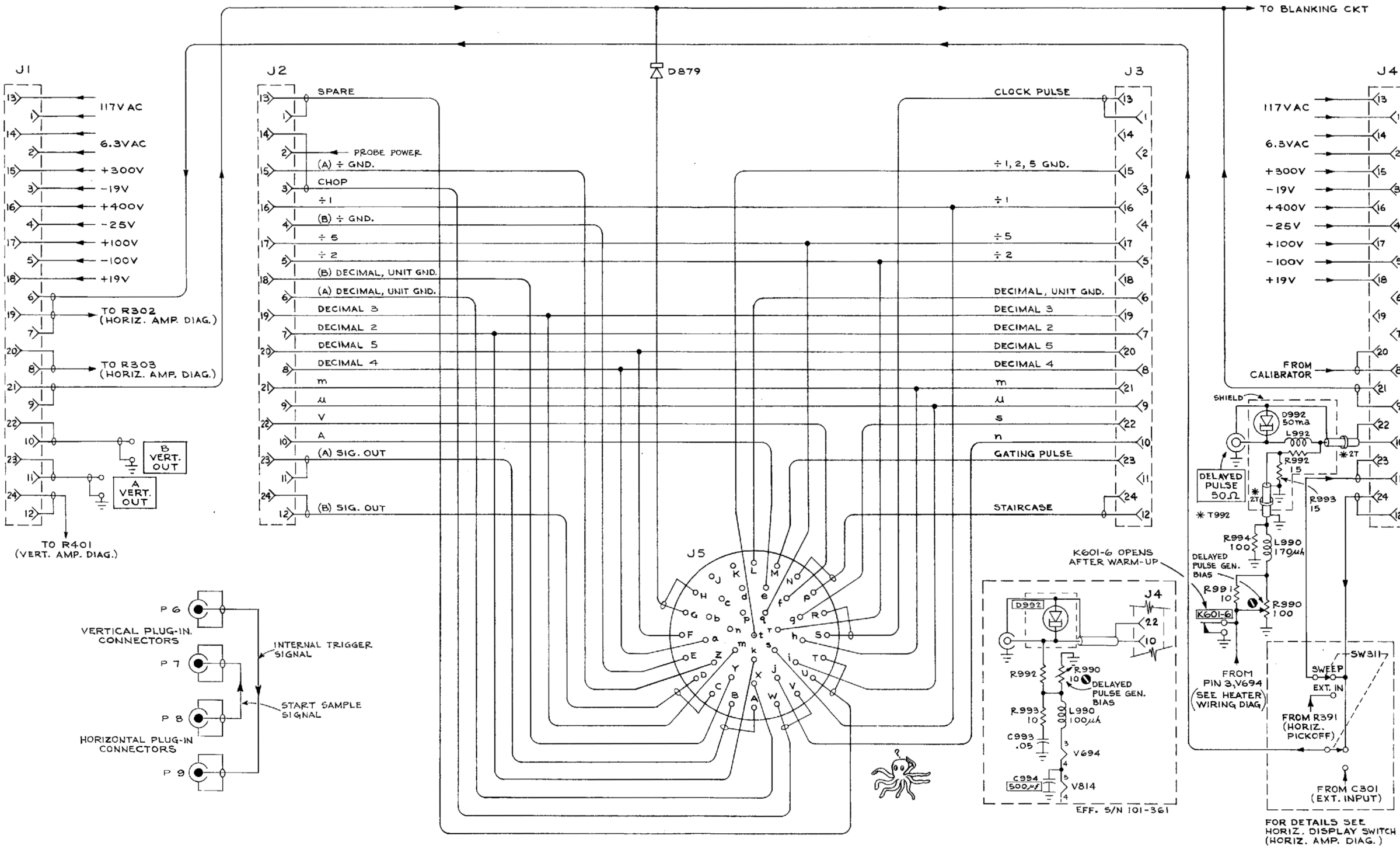

CONNECTORS FOR VERTICAL PLUG-IN

CONNECTORS FOR HORIZONTAL PLUG-IN

SEE PARTS LIST FOR EARLIER VALUES AND S/N CHANGES OF PARTS MARKED WITH BLUE OUTLINE

MR H 1064

MANUAL CHANGE INFORMATION

At Tektronix, we continually strive to keep up with latest electronic developments by adding circuit and component improvements to our instruments as soon as they are developed and tested.

Sometimes, due to printing and shipping requirements, we can't get these changes immediately into printed manuals. Hence, your manual may contain new change information on following pages. If it does not, your manual is correct as printed.

TYPE 661

PARTS LIST CORRECTION

CHANGE TO:

F601

159-0023-00

Fuse, 2 A slo-blo 234 V 50 & 60 cycle

M10892/466

TYPE 661 TENT SN 2920

PARTS LIST CORRECTION

CHANGE TO:

B388	150-0030-00	Bulb, neon, NE-2V
B389	150-0030-00	Bulb, neon, NE-2V
B468	150-0030-00	Bulb, neon, NE-2V
B469	150-0030-00	Bulb, neon, NE-2V

Type 661 Tent S/N 2830

PARTS LIST CORRECTION

Remove :

D879	152-0025-00	Diode, 1N634
J3	131-0148-00	Connector, 24 contact
J5	131-0212-00	Connector, 41 contact

M9323/166

SCHMATIC CORRECTION

Remove all of below circuitry except J2 and Pin 2 (Probe power).

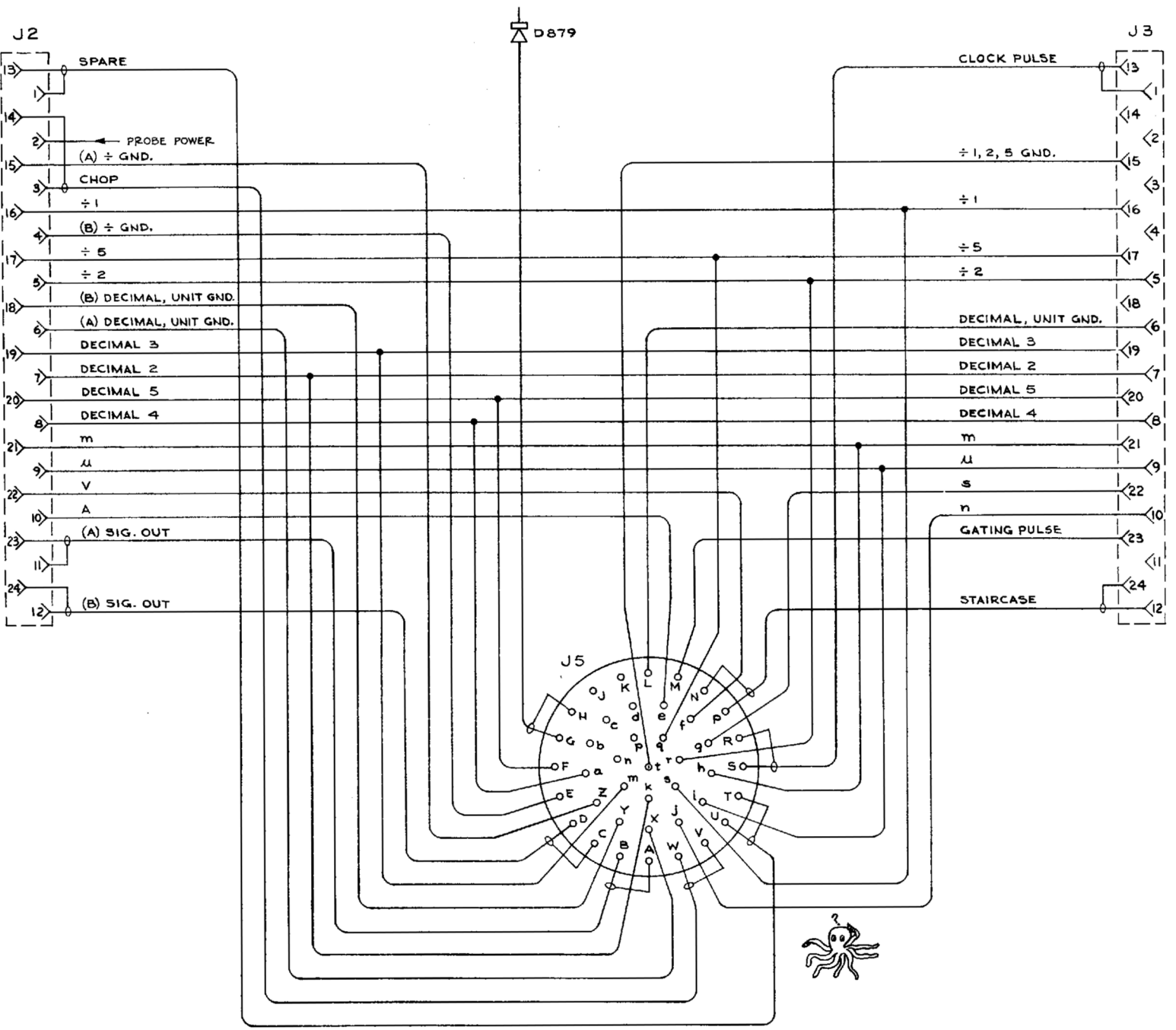

PART. INTERCONNECTING SOCKETS

TYPE 661
Text Correction

Section 1, page 1-1, Delayed Pulse paragraph:

Third line, change 70 picoseconds to 150 picoseconds.

Sixth line, change 350 picoseconds to 380 picoseconds.

Seventh line, change 115 picoseconds to 180 picoseconds.

Section 2, page 2-2, DELAYED PULSE 50 Ω paragraph:

Fifth line, change 70 picoseconds to 150 picoseconds.

Type 661 Tent S/N 2700

Parts List Correction

Change To:

C809	283-0619-00	.001 μ f	mica	1500V
------	-------------	--------------	------	-------

M9888/965

Type 661 Tent S/N 2700

Parts List Correction

Change To:

C934	281-0603-00	39pf	Cer.	500V	5%
C935	281-0562-00	39pf	Cer.	500V	
C936	283-0003-00	.01 μ f	Disc.	150V	
C942	281-0093-00	5.5-18pf	Cer.	Variable	
C968	281-0093-00	5.5-18pf	Cer.	Variable	
C971	281-0091-00	2-8pf	Cer.	Variable	

TYPE 661 -- TENT. S/N 2610

PARTS LIST CORRECTIONS

CHANGE TO:

D644	152-0185-00	Replaceable by 1N3605			
R643	301-0202-00	2 k	1/2 w		5%
R644	315-0201-00	200 Ω	1/4 w		5%
R649	308-0153-00	100 Ω	10 w	WW	5%

ADD:

R659 ¹	308-0174-00	117 Ω	8 w	WW	5%
-------------------	-------------	--------------	-----	----	----

¹ Added in parallel with R649.

M9468/665

TYPE 661 -- TENT. S/N 2600

PARTS LIST CORRECTIONS

CHANGE TO:

D312	152-0185-00	Replaceable by 1N3605
D313	152-0185-00	Replaceable by 1N3605

M9342/665