

**TECHNICAL
INSTRUCTION and
TRAINING for the**

1A2

1A2

Written and Produced in Field Training

Material in this Training Package
is company confidential -

For Internal Use Only

Copyright 1964, TEKTRONIX, INC.

Beaverton, Oregon
All Rights Reserved

CONTENTS

1. GENERAL INFORMATION
2. CIRCUIT DISCUSSION
3. GRAPHIC CALIBRATION PROCEDURE
4. SCHEMATICS

TYPE 1A2 DUAL-TRACE PLUG-IN UNIT

POSITION
CH 1 & 2 IN ADD ONLY

VAR
ATTEN BAL

POSITION

VAR
ATTEN BAL

**CALIBRATED
PREAMP**

MODE
ADD
CH 1 CH 2
ALT CHOP

**VARIABLE
VOLTS/CM**

GAIN
ADJ

2 1 .5
5 10 20 .2 .1 .05

PULL TO
INVERT

CHANNEL 1

AC DC GND

INPUT 1

1 MEG
≈ 15 pf

**VARIABLE
VOLTS/CM**

GAIN
ADJ

2 1 .5
5 10 20 .2 .1 .05

PULL TO
INVERT

CHANNEL 2

AC DC GND

INPUT 2

1 MEG
≈ 15 pf

SERIAL

TEKTRONIX, INC.

PORTLAND
OREGON, U.S.A.

TYPE 1A2
GENERAL INFORMATION

The Type 1A2 is a wide band, dual-trace, vertical plug-in pre-amplifier designed for use with any 530, 540, 550, or 580 (with type 81 adapter) series oscilloscope.

Channel 1 and Channel 2 amplifiers are identical. They can be added algebraically, operated singly with either polarity, or dual-trace with either alternate or chopped switching. In chopped operation, electronic switching occurs at a 220 KC rate to show successive 2 μ sec samples of each trace. The 220 KC chopping rate was chosen as a one upmanship factor over a BRAND X plug-in. In alternate operation, with a Type 547 oscilloscope in an alternate sweep switching mode, pulses can be supplied to the switching circuit to slave Channel 1 to Time Base A and Channel 2 to Time Base B.

Frequency response in a Type 547, 546, or 544 oscilloscope is from DC to at least 50 MC (3-db down). The frequency response in other Tektronix Type 540 series oscilloscopes and in 550 and 580 (with the 81 adapter) series oscilloscopes is DC to at least 33 MC (3-db down). The frequency response in Type 530 oscilloscopes is DC to at least 15 MC (3-db down).

Sensitivity from 50 mv/cm to 20 v/cm is in 9 calibrated steps with 1-2-5 sequence, accuracy within $\pm 3\%$. A variable control permits continuous adjustment uncalibrated from 50 mv/cm to approximately 50 v/cm.

Polarity inversion for both channels can be used to compare signals 180° out of phase.

AC or DC coupling or grounding of the input is controlled from the front panel. With AC coupling the low-frequency 3-db point is 2 cps.

Common mode rejection in the added-algebraically mode is at least 20:1 up to 50 MC. (This is a tentative specification. MSE will not determine the permanent spec until about week 23).

Maximum input is 600 volts (DC + peak AC).

Input impedance is 1 megohm paralleled by 15 pf.

TYPE 1A2

CONTROLS AND CONNECTORS

The following are duplicated in Channel 1 and 2, and operate independently:

1. VOLTS/CM: A 9 position switch that selects the calibrated input sensitivities. Range is from 50 mv/cm to 20 v/cm.
2. VARIABLE VOLTS/CM: Capable of reducing selected calibrated sensitivities by a factor of at least 2.5:1.
3. INPUT COUPLING: Selects AC or DC coupling to the input of the preamplifier. In the GND position, the input is disconnected from the circuit under test and the input of the preamplifier is grounded.
4. POSITION: Positions the trace vertically on the CRT. In the ADD mode, only the Channel 1 POSITION control operates.
5. PULL TO INVERT: This control provides polarity inversion of the display.
6. VAR ATTEN BAL (screwdriver adjustment): A DC balance control which is adjusted so there is no trace shift as the VARIABLE VOLTS/CM control is rotated full CW and CCW.
7. GAIN (screwdriver adjustment): With a known input signal (such as the calibrator), the oscilloscope can be adjusted to the calibrated sensitivity.

The MODE switch has five positions and affects both channels.

1. ALT: Each channel is displayed on alternate sweeps of the time base. With a 547 set for alternate time base switching, channel 1 can be slaved to A time base and Channel 2 to B time base.
2. CH 1: Channel 1 only is displayed.

3. ADD: The output of each channel is added algebraically to form one composite vertical signal. The Channel 2 POSITION control does not operate in this mode.
4. CH 2: Channel 2 only is displayed.
5. CHOP: Each channel is displayed alternately for approximately 2 μ sec. (220 KC rate).

Handwritten notes on the left side of the page, including the number '2' at the bottom.



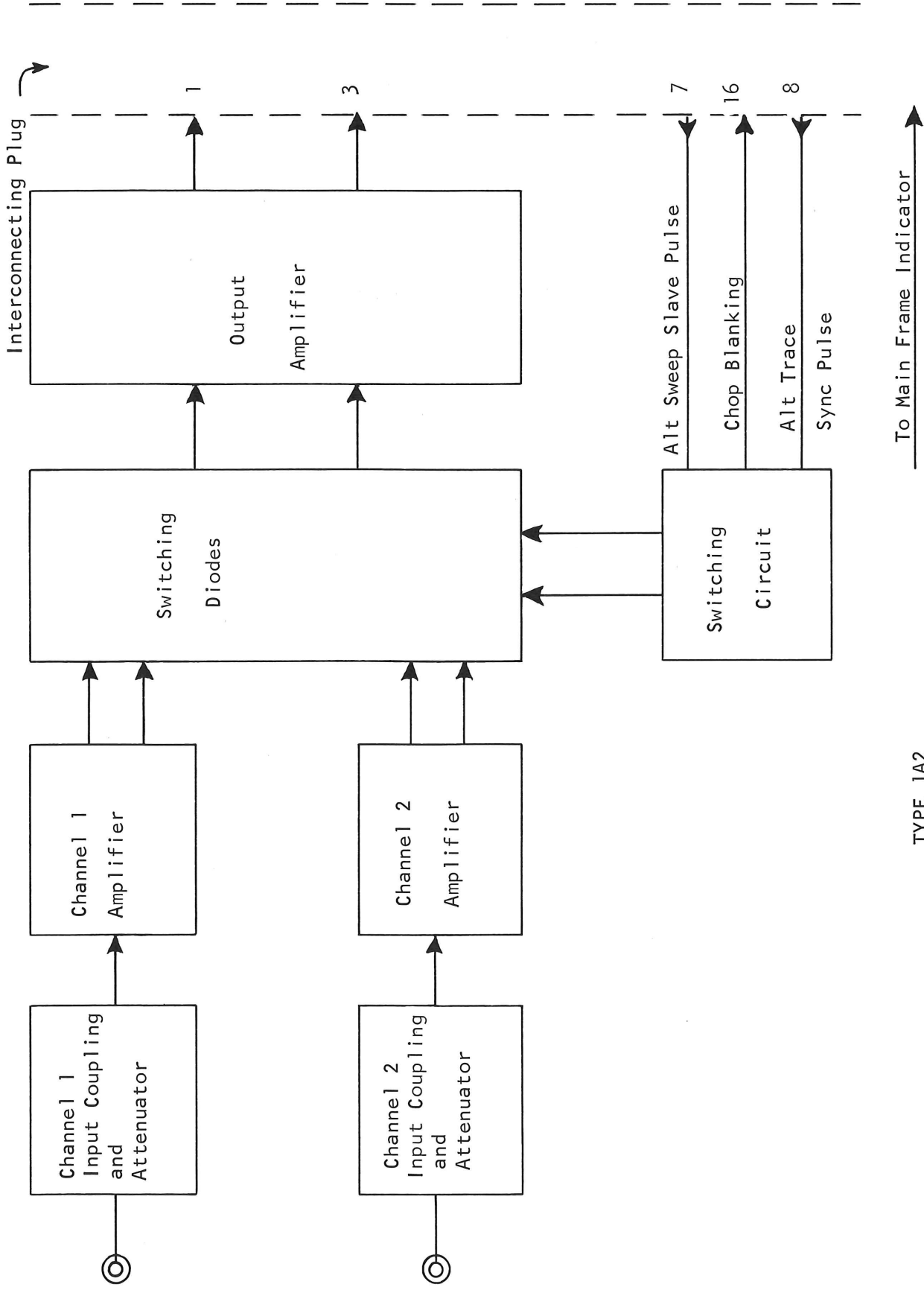

TYPE 1A2
SYSTEM Block Diagram

THE OVERALL SYSTEM

The 1A2 was designed as an inexpensive dual-trace plug-in. The 1A2 consists of a Channel 1 amplifier, a Channel 2 amplifier, an output amplifier, and a switching circuit. A block diagram is shown in Figure 1.

The Channel 1 and Channel 2 amplifiers are identical and operate independently. The output of either amplifier, a current drive of approximately $462 \mu\text{a}$ per side, is selected by the switching circuit to feed the output amplifier. Each amplifier consists of an INPUT COUPLING switch, an attenuator, an Input CF, a paraphase amplifier, a PULL TO INVERT switch, and a POSITION control.

The following applies to both amplifiers:

The INPUT COUPLING sw provides AC or DC or ground to the input of the preamplifier.

The attenuator provides input sensitivities from 50 mv/cm to 20 v/cm and allows the circuit under test to see an input impedance of $1 \text{ M}\Omega$ shunted by 15 pf.

The Input CF and paraphase amplifiers are protected against excessive + and - signals.

The gain adj. and the VARIABLE control are part of the emitter coupling network in the paraphase amplifier circuit.

The VAR ATTEN BAL pot sets the base voltage of the undriven side of the paraphase amplifier.

The paraphase amplifier is temperature compensated.

The PULL TO INVERT sw provides a means of inverting the amplifier output 180° .

In the added mode of operation, the Channel 2 POSITION control is switched out of the circuit and vertical positioning is accomplished by the Channel 1 POSITION control only. In all other modes, both POSITION controls operate.

The output amplifier consists of a hybrid cascode amplifier, an output EF, and the high frequency adjustments. Its input signal is selected by the switching diodes.

The hybrid amplifier is composed of a common base transistor feeding a common grid tube and is used to provide a linear response with the required gain. The common base configuration provides a low input impedance to the current drive from the paraphase amplifier. The tube shifts the DC level about 55v to make the 1A2 compatible with all scopes that accept a lettered series plug-in.

In the ADD mode, a bleeder network is tied into the emitter circuit of the hybrid amplifier which bleeds off 15 ma, maintaining a quiescent tube current of 7.5 ma, per side.

To provide proper temperature compensation for the paraphase amplifier, the DC level at the emitters of the common base transistor must be tightly controlled. Since a 10% zener is used for the +12v supply, a more accurate voltage is necessary to set the emitter level. The +10v supply is adjustable and thus, provides the required accuracy.

The output EF provides an output impedance of 60Ω . A variable resistance sets the output DC level of the EF to 67.5v.

The high frequency adjustments consist of 2 adjustable RC networks that are tied across the output of the plug-in. When the K and L plug-ins were designed, the required frequency response could not be obtained. The 540A main frames were spiked up to compensate for the plug-ins. These RC's are adjusted to compensate for the spike in the 540A main frames.

The switching circuit consists of the switching diodes, the switching multivibrator, and the trigger B0. The switching diodes are of the series-shunt configuration and are controlled by the switching multivibrator, in a manner similar to the 1A1 and 10A2 circuits. When the shunt diodes of a particular channel are turned off the output of that channel is fed to the output amplifier through the series diodes. When

a channel is turned off (its shunt diodes are on), current is supplied to the paraphase amplifier of that channel from the switching multi-vibrator through the shunt diodes.

The switching multi, which is bistable in all modes, is controlled by the MODE sw and the trigger B0. Since the voltage swing at the emitters of the hybrid amplifier is small (it is current driven), the required voltage swing at the multi output is correspondingly small.

In the ALT and CHOP modes, the multi's switching rate is determined by the trigger B0. In the ALT mode, the B0 receives a signal at the end of each sweep which causes it to send a trigger to the multi. With a 547 whose HORIZONTAL DISPLAY is set to A ALT B, triggers are sent to the B0 and to the multi which lock Channel 1 to time base A and Channel 2 to time base B.

In the CHOP mode of operation, the B0 free runs to send triggers to the multi at a 440 KC rate. The multi divides by 2 to provide a 220 KC chopping rate. The B0 also provides blanking pulses in the CHOP mode.

CIRCUIT DESCRIPTION

CHANNEL 1

Input Circuitry

The signal is fed from J101 to the input CF through the INPUT COUPLING and attenuator switches. The INPUT COUPLING sw is a 3 position lever switch which provides AC, DC, or GND coupling to the plug-in. In the AC position, the signal is fed through a .1 μ f cap (600v) and the lower 3-db frequency is 2 cps. In the GND position, the signal under test is disconnected at the INPUT COUPLING sw and the grid of the input CF is grounded through the attenuator.

The attenuator has 9 positions with attenuation from X1 to X400 which provides input sensitivities from 50 mv/cm to 20 v/cm. The straight-through standardizer, C104, is switched in the X1 position only. All positions have adjustable RC compensation. Some positions have non-adjustable RL compensation to improve the high frequency response. Some positions also use small additional resistors to prevent ringing. R103 and C103 are part of the attenuator.

The Input CF is of the same configuration as the 1A1's Input CF. Its plate supply is +100v through D134. Protection from excessive - signals is provided by B118. The neon will fire when the grid becomes 73v more negative than the cathode and will then maintain a grid-cathode potential of -55v. (All voltages are design center unless otherwise stated). B118 also provides protection against excessive + signals in the same manner.

Protection from excessive + signals is also provided in the cathode, grid, and plate circuits. R117 (470K) limits grid current when the grid goes + with respect to the cathode. C117 (.0056) is a high frequency bypass cap.

At quiescence, the DC level at the cathode of the nuvistor is +1.7v and at the cathode of D138 is +3.7v. As the grid goes +, the cathode will follow until the voltage at the anode of D138 (cathode of V133) rises

to 4.4v which causes D138 to conduct. When D138 conducts, it shunts the cathode network of V133, R133 and R136. The tube is now supplied current from ground through the low impedance of the VAR ATTEN BAL circuit. The R_k of the tube is about 125Ω at this time and the gain of the Input CF stage will fall to about .01. Since the undriven side of the paraphase amplifier is tied to the VAR ATTEN. BAL control, its base will go + as the base of the driven side goes +. With both bases following the same rise in potential, the effects of an excessive + signal are partially cancelled common mode at the paraphase amplifier. Thus the same circuitry protects both the input CF and the paraphase amplifier from excessive + signals.

If V133's current increased to about 12.5 ma, the plate voltage would go "down", cutting off D134. Now further increases in tube current are resisted by R134 and the maximum tube current is limited to approximately 15 ma.

The conditions described above occur when an excessive + signal is first applied. There will be a finite time lag before the neon will ionize and before the effects of grid current will be counteracted by R117.

The paraphase amplifier is also protected against excessive - signals by D137. When the potential at the cathode of D137 falls to -.7v, D137 conducts protecting the paraphase amplifier from an excessive - drive.

R136 prevents the Input CF from presenting a negative input impedance to the circuit under test.

The maximum allowable grid current is 5 nanoamps which develops a 5 mv drop across R115. This is only 1 mm of deflection as seen on the CRT and is not considered sufficiently annoying to warrant a grid current null adjustment.

Channel 1 Control Circuits

The VAR ATTEN BAL control sets the base DC level of the undriven side of the paraphase amplifier. This control is adjusted for no trace shift as the VARIABLE is rotated. The setting of the VAR ATTEN BAL pot is specified at 90° from center ($+1.7v \pm .6v$). If the nuvistor bias is too far from design center, the VAR ATTEN BAL pot can not make this spec. The coaxial leads to the VAR ATTEN BAL pot are used to keep spurious signals out of the paraphase amplifier. C159 is a high frequency bypass cap. R159 is used to present a resistive load to the base of the undriven side of the paraphase amplifier.

The PULL TO INVERT sw and the POSITION control are tied across the collector circuit of the paraphase amplifier. The PULL TO INVERT sw provides a 180° phase inversion of the current drive to the output amplifier.

The only difference in the Channel 1 and Channel 2 circuits is the operation of the Channel 2 POSITION control. The MODE sw disconnects the Channel 2 POSITION control in the added mode.

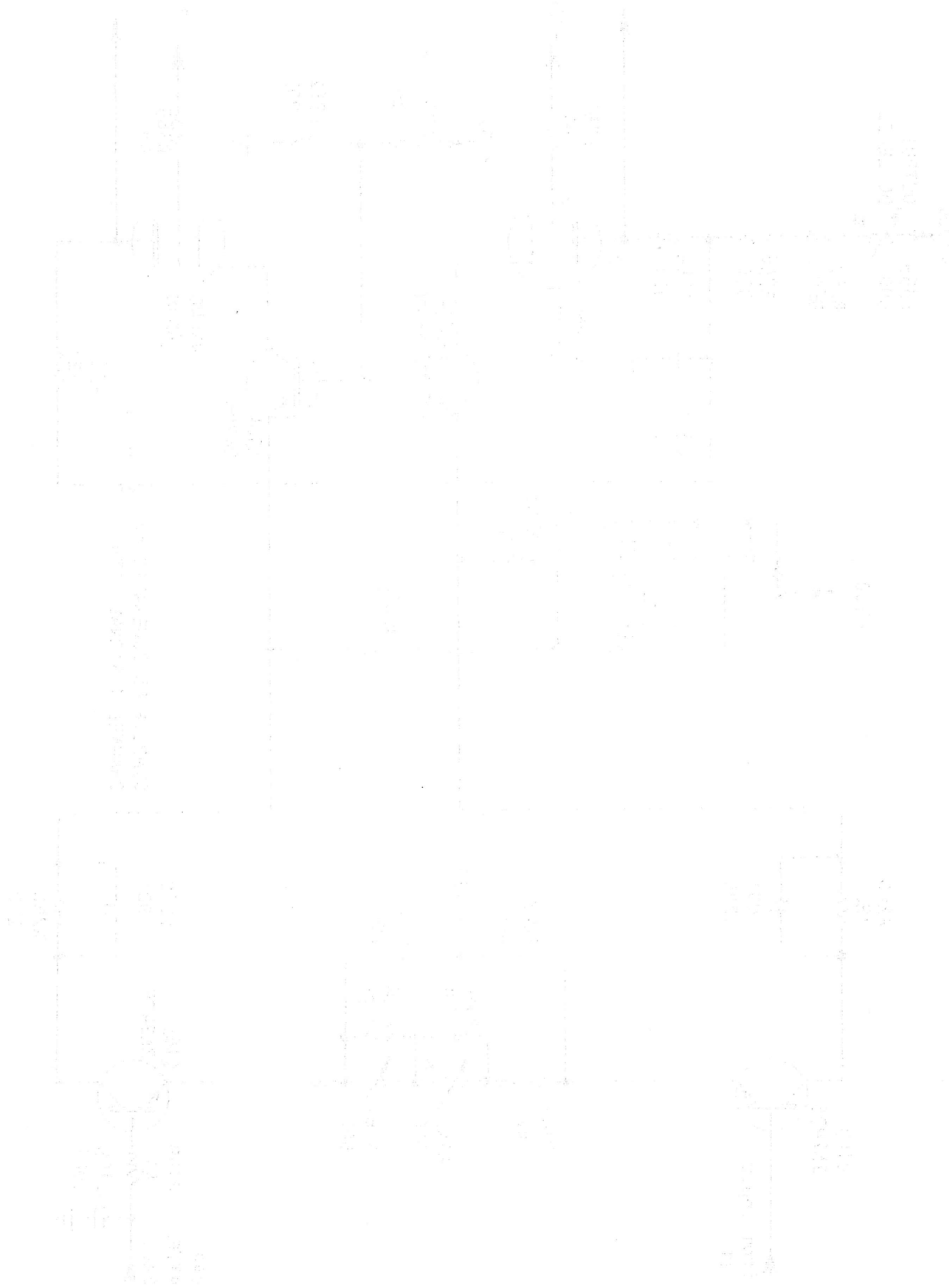

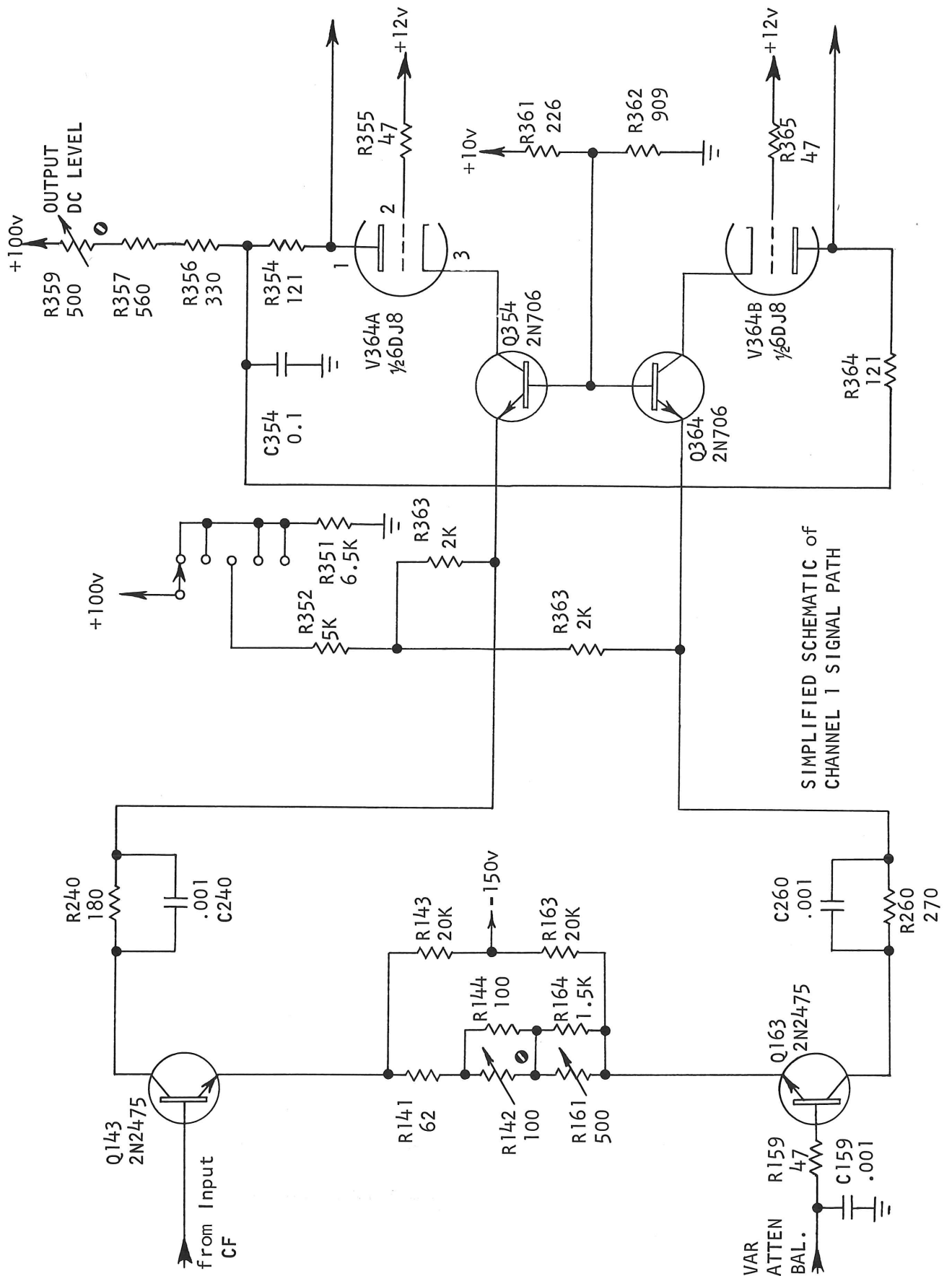

Channel 1 Signal Path

A simplified schematic of the Channel 1 signal path is shown in Figure 2. The input circuitry, PULL TO INVERT switch, POSITION control, the switching diodes, and the output EF have been removed for convenience. The paraphase amplifier and hybrid cascode amplifier can be considered as a single stage of voltage amplification. The gain of the stage is approximated by dividing the plate load resistance of V364 (121Ω) by the emitter coupling resistance of Q143 and Q163. Quiescent current is determined by the longtail circuit, R143 and R163 (20K) to -150v, 7.5 ma. R142 (100Ω), the Gain adj., is set to provide an emitter coupling resistance of about 121Ω . Thus, the amplifier will have a gain of 1 per side, a push-pull gain of 2. The VARIABLE control, R161 (500Ω), which is shunted by R164 (1.5K), provides a means of decreasing stage gain by a factor of at least 2.5:1.

R140 (180Ω) and R160 (270Ω) are temperature compensators. C140 and C160 (.001) are high frequency compensators. The base voltage of Q354 and Q364 is set by the +10v supply to provide exact temperature compensation of the paraphase inverter. This insures the quiescent drop across Q143 and Q163 will equal the drop across their external circuits (those components that determine the slant of their load lines).

To determine the current drive necessary to produce an output signal of 50 mv/cm, each side, we first divided R354-R364 into 50 mv, about $413\ \mu\text{a}$. We next took into account the alpha loss in the common base transistors, Q354 and Q364, and the alpha loss in the paraphase amplifier, Q143 and Q163. Since the alpha of these transistors is about .97, we squared .97 to obtain .94 and then divided .94 into $413\ \mu\text{a}$ to obtain a drive of $439\ \mu\text{a/cm}$, to Q354-Q364. The voltage drive to the paraphase amplifier can be obtained by multiplying the input voltage by .95. To compensate for this loss we divided $439\ \mu\text{a/cm}$ by .95 to obtain a current drive of $462\ \mu\text{a/cm}$ from the paraphase amplifier to Q354-Q364.

The voltage gain of the output EF is approximately .995. Since this figure is so near unity, we did include it in our gain calculations.

In the ADD mode R353, R363 (2 K's) and R352 (5K) bleed off excess current to maintain a quiescent current of 7.5 ma, per tube. In all modes other than ADD, R351 (6.5K) provides a constant load to the +100v supply. The actual value of the +100v supply in the plug-in is usually about 95v (decoupled). If R351 was not placed in the circuit, the change in current through the decoupling resistors in the main frame would cause the voltage to rise to about +97v.

V364 shifts the DC level in the hybrid cascode circuit about 55v. The base of Q373 and the base of Q383 are tied to pins 1 and 6, respectively of V364. The plate voltage of each half of the tube is about +68.2v, which puts the emitters of Q373 and Q383 at +67.5v. R359 is adjustable so the emitters can be set to exactly +67.5v, which will insure the plug-in's compatibility with all other Tek scopes that accept lettered series plug-ins.

T301 and T310 are used to prevent oscillations in the ADD mode. They act as parasitic suppressors by providing common mode signal decoupling. The output EF provides an output impedance of about 60Ω to drive the main frame vertical. R375 and R385 (51Ω each) in series with the internal emitter resistance of Q373 and Q383, about 9Ω each, compose the 60Ω output impedance. Current is set by the longtail circuit, R373 and R383 (9.1K) to +12v.

The high frequency adjustments are connected across pins 1 and 3 of the interconnecting plug. One RC network, R379 (500Ω) and C379 (3-12 pf), is adjusted for a 7 nanosec time constant. The other RC network, R377 (10K) and C377 (5-25 pf), is adjusted for a 100 nanosec time constant.



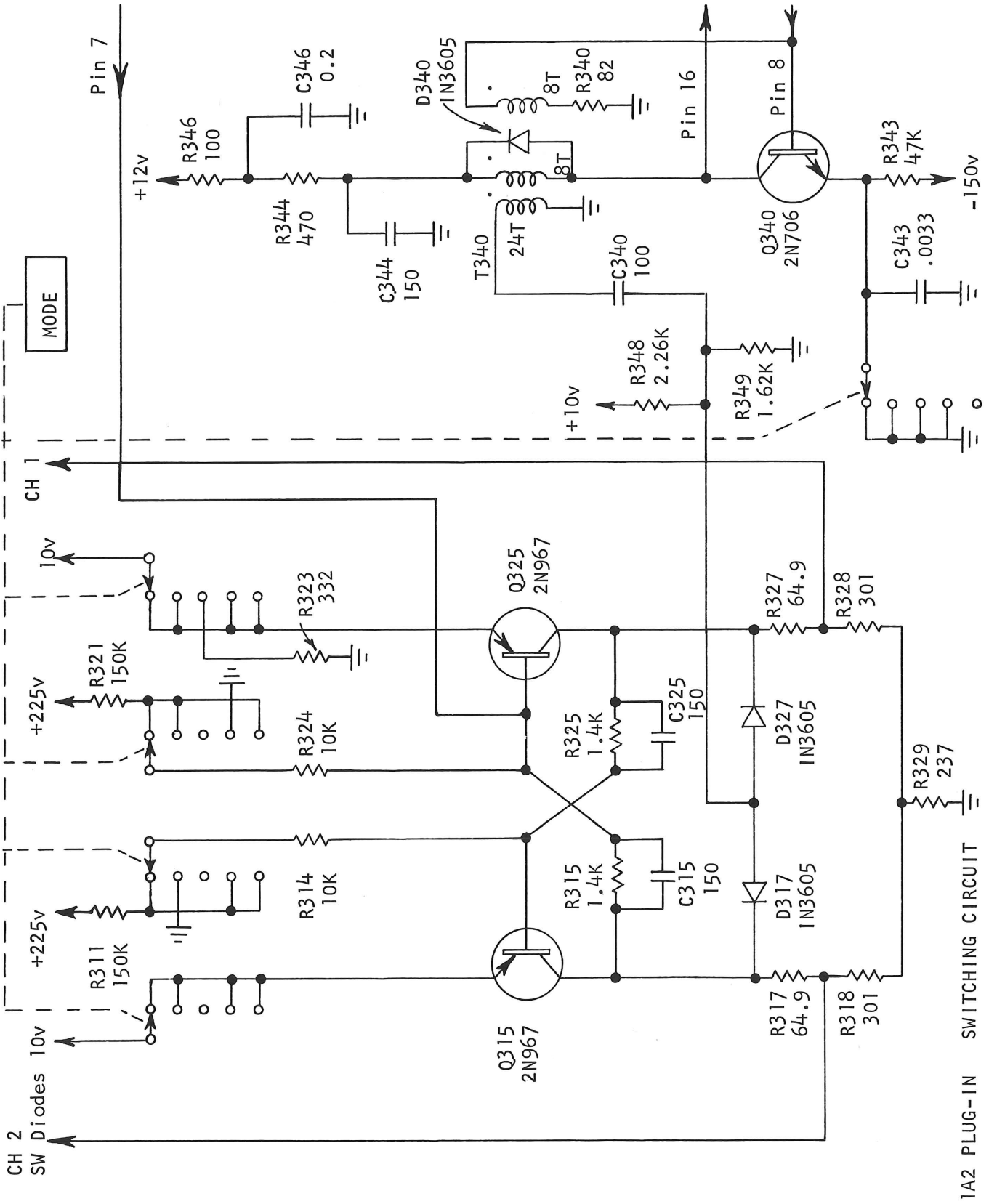

Switching Circuit

The switching circuit consists of a switching multi and a trigger B0. A schematic of the switching circuit is shown in Figure 3. The switching multi is controlled by the MODE switch and trigger B0. It is a collector steered, collector triggered, bistable multi. Q315 controls the Channel 2 switching diodes and Q325 controls the Channel 1 switching diodes. To apply the output of the Channel 1 amplifier to the output amplifier D302 and D303 must be turned off. When Q325 is off, its collector is down and D302 and D303 will be turned off. At this time Q315 is on and its collector is up, forward biasing D307 and D308. The Channel 2 signal current is shunted to +10v through R317 and Q315. Since the voltage swing at the emitters of Q354 and Q364 is minute, a voltage swing of 3v at the junction of R327 and R328 (R317 and R318) is more than sufficient for proper switching action.

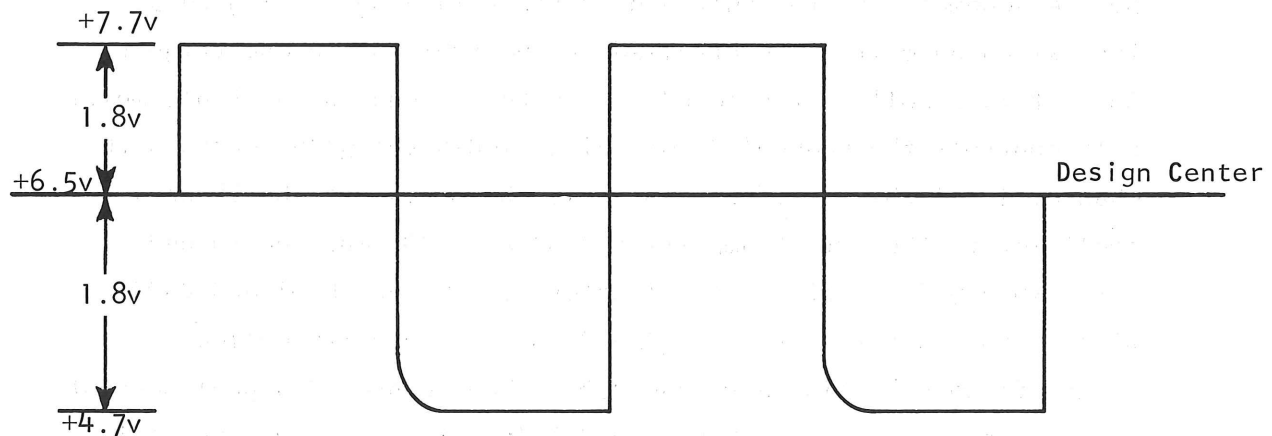

Output of switching multi with respect to the DC level at the emitters of Q354 and Q364.

Figure 4

Figure 4 shows the amplitude relationship of the multi output to the emitter voltage of Q354 and Q364. Note that when the multi output is negative going, the fast portion of the pulse is used to switch the diodes.

In the ADD mode, both transistors are off and R323 (332 Ω) is switched in to provide a constant current drain to the +10v supply, which insures that the +10v will remain constant.

In the ALT and CHOP modes, pulses are supplies from the trigger B0 to switch the multi. With a 547 whose HORIZONTAL DISPLAY is set to A ALT B, a - going step is sent to the base of Q325 through C326 (47 pf) at the end of each A sweep. C326 differentiates the step to provide a sharp trigger pulse to turn on Q325. Thus the Channel 2 output will be displayed on the following B sweep. At the end of the B sweep, the trigger B0 receives a signal that tells it to trigger the switching multi. Since the output of the B0 always tells the on transistor to turn off, Q325 will turn off and

and Q315 will now turn on. The output of Channel 1 will be displayed on the following A sweep. The sweep switching circuit in the 547 will not trigger the B0 after an A sweep, it will only trigger the multi directly to insure alternate slaving.

Figure 5 shows the time relationship between the A sweep, B sweep, the ALT SWEEP SLAVE PULSE, and the ALT TRACE SYNC PULSE.

The ALT SWEEP SLAVE PULSE waveform shown in Figure 5, is representative of the signal applied to C326.

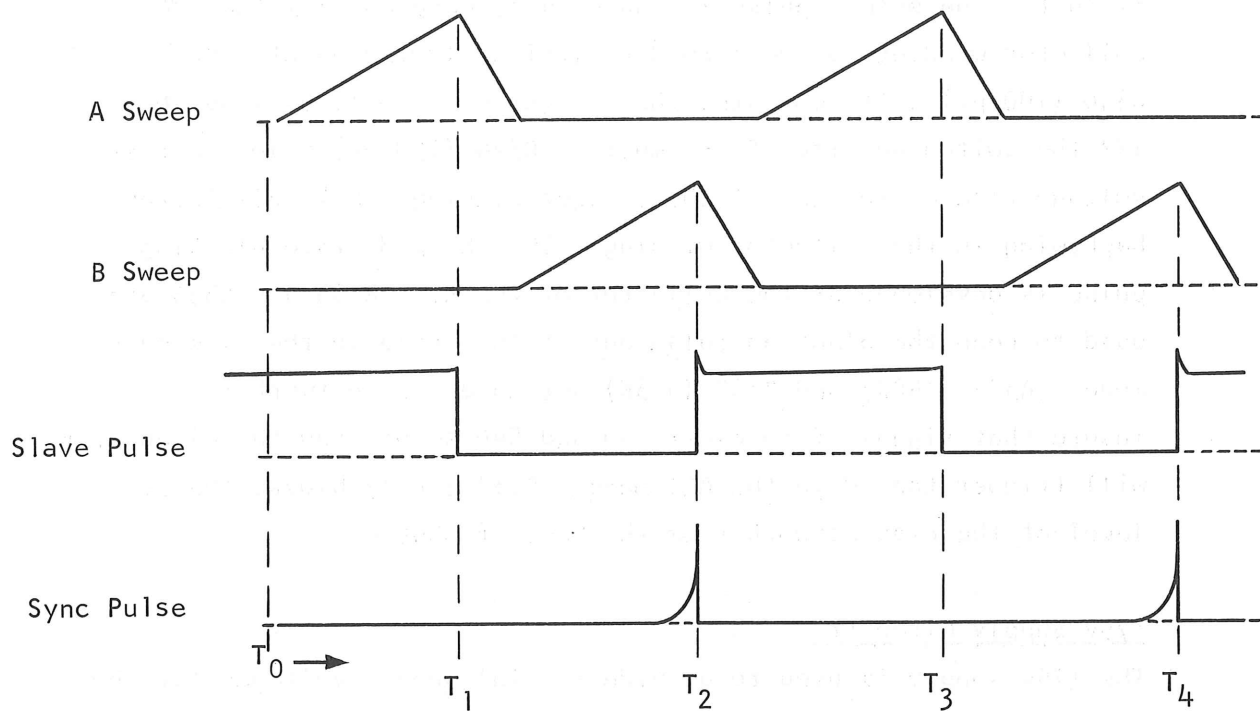

Time relationship of the slave & sync pulses to A and B sweeps when the Horizontal display of a 547 is set to A ALT B.

Figure 5

The voltage divider network of R348 (2.26K) and R349 (1.6K) biases the anodes of D317 and D327 at +4.2v. This bias voltage insures that the diodes will be reversed biased, except when a trigger is applied, and will not load the multi.

In the CHOP mode, the B0 is free running and will turn on when its emitter becomes .7v negative with respect to the base. R344 (470 Ω) in the collector and R340 (82 Ω) in the base circuit limit the current the B0 can draw when Q340 is turned on. The effect of R344 and R340 is to make the pulse repetition rate of the B0 independent of the transistor and transformer parameters and dependent on the RC time constant (.0033 x 47K) of the emitter circuit. The output pulse is inductively coupled from the collector winding to the secondary (trigger) winding of T340. C340 (100 pf) differentiates the trigger so it will be less than 1/2 the switching time of the multi. C344 (150 pf) allows a fast voltage rise at the top of the trigger winding. D340 eliminates backswing in the collector winding. The chopped trace blanking pulse is developed at the collector of the B0. R334 and C335 are used to keep the blanking pulse out of the cable in the alternate mode. R333 (150K) and R332 (3.3K) set up a bias network to insure that signals from older 530 and 540 scopes and the 81 adapter will trigger the B0 in the ALT mode. C333 (.001) blocks the DC level of the bias network from the base of Q340.

+75v Supply Circuitry

The +75v supply is used to provide special supply voltages for the 1A2 circuitry and to supply filament current for the nuvistors. It is developed in the main frame by supplying filament current for 2 tubes and thus requires a constant current of 150 ma. R391 (390 Ω) limits the nuvistor's filament voltage drop. If a nuvistor is removed from its socket while the 1A2 is plugged in, R390 will also be removed. The +12v supply is developed across D395, a 10% zener. R396 (200 Ω) is the +10v adjustment. The +13v is used only to supply the VAR ATTEN BAL controls. As the position

of the VAR ATTEN BAL pot in one channel is changed, it will change the current through R393 and thus the actual value of the +13v supply, and therefore the VAR ATTEN BAL adjustments interact.

1A2 GRAPHIC CALIBRATION PROCEDURE

The following calibration procedure is a step-by-step graphic training device. This procedure is intended for the use of Tektronix personnel. Specifications listed are factory specs and are not guaranteed unless they also appear as catalog or instruction manual specifications. Factory specs are usually tighter than catalog specs. This assures the instrument of meeting or exceeding advertised specifications after shipment and over years of use.

To accomplish the calibration of a 1A2, a new type 540 series oscilloscope should be used. (544, 546, or 547). If an older type 540 series or a 530 series or a 550 series oscilloscope is used, the high frequency response of the 1A2 can not be calibrated.

For this procedure, a 547 was used. If other than the 547 is used, the front panel controls mentioned in this graphic calibration procedure will have to be interpreted and applied to your particular arrangement.

Equipment Required:

1. Type 547 oscilloscope or equivalent (50 MC passband)
2. Type 105 square wave generator
3. Type 190B constant amplitude signal generator or equivalent
4. 15pf Capacitance Standardizer (011-073)
5. 50 Ω Terminator (011-049)
6. Type TU-5 tunnel diode pulser
7. Several BNC cables or patch cords and BNC to UHF adapters
8. Adjusting tools
9. DC Voltmeter, 20,000 Ω/V , 1.5% at 2 KV

The physical layout of the IA2 is such, that no plug-in extensions need be used for calibration. The high frequency adjustments are located on a bracket adjacent to the interconnecting plug. The +10 volts and the Output Voltage pots are located on the Chassis immediately in front of the high frequency adjustments. The Gain and VAR ATTEN BAL adjustments for both channels are located on the front panel.

Remove the left side panel and the bottom panel from the oscilloscope. Insert the IA2 into the plug-in box. Lay the scope on its right side. (It may be helpful to prop up the scope on a small block of wood). Apply power and allow approximately 15 minutes for warm-up.

Preset the IA2 front panel controls as follows:

CH 1 and CH 2

INPUT COUPLING	GND
VOLTS/CM	.05
VARIABLE VOLTS/CM	CALIBRATED (fully CW)
POSITION	Midrange
PULL TO INVERT	not pulled
MODE	CH 1

Preset the 547 front panel controls as follows:

HORIZONTAL DISPLAY	B
SWEEP MODE	NORMAL
SWEEP MAGNIFIER	X1 (off)
B TIME/CM	1 msec
B TIME/CM VARIABLE	CALIBRATED
B TRIGGERING CONTROLS	
MODE	AUTO
SLOPE	+
COUPLING	AC
SOURCE	NORM-INT
LEVEL	CW

With the FOCUS and ASTIGMATISM controls obtain a sharply defined trace.

Since the Channel 1 and Channel 2 amplifiers are identical, the following steps will be written for Channel 1. The Channel 2 adjustments will be placed in parenthesis following the Channel 1 adjustments.

There were some mechanical changes late in phase B. These changes delayed the manufacture of silk-screened units. Thus, we were unable to obtain a silk-screened unit for this package. The mechanical layout shown in these pictures is very close to the production layout.

I. 1A2 INTERNAL VOLTAGE SUPPLIES

A. + 12v supply

1. Connect the voltmeter from the cathode of D395 to ground. See Figure 1.

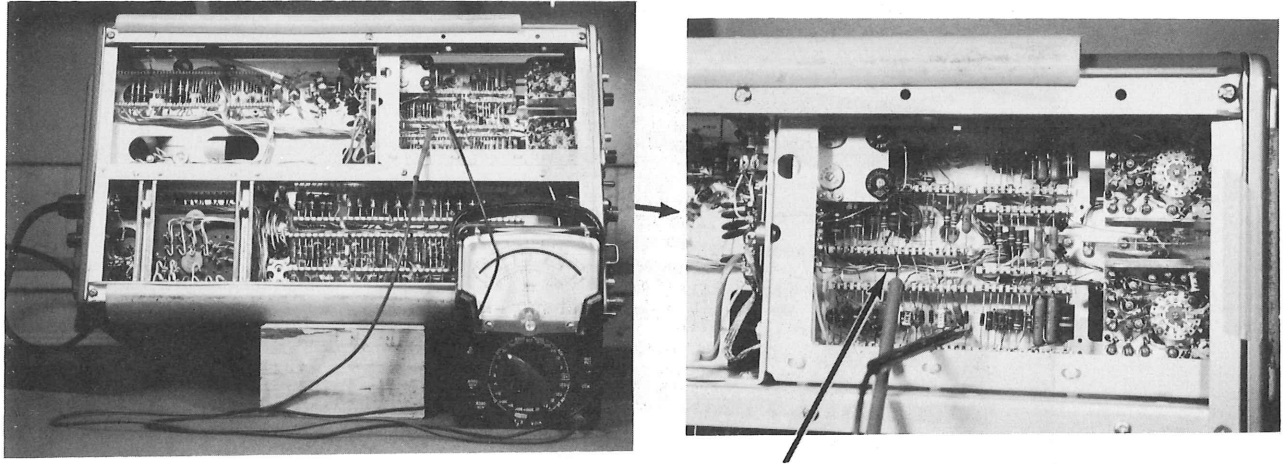

+12v supply (zener voltage) monitored at the right side of R346.

Figure 1

2. Check the voltage developed across D395.
 - a. $+12v \pm 10%$ (13.2v to 10.8v)

B. +10 Volts

1. Disconnect the meter from the cathode of D395 and connect it to the +10v test point. See Figure 2.

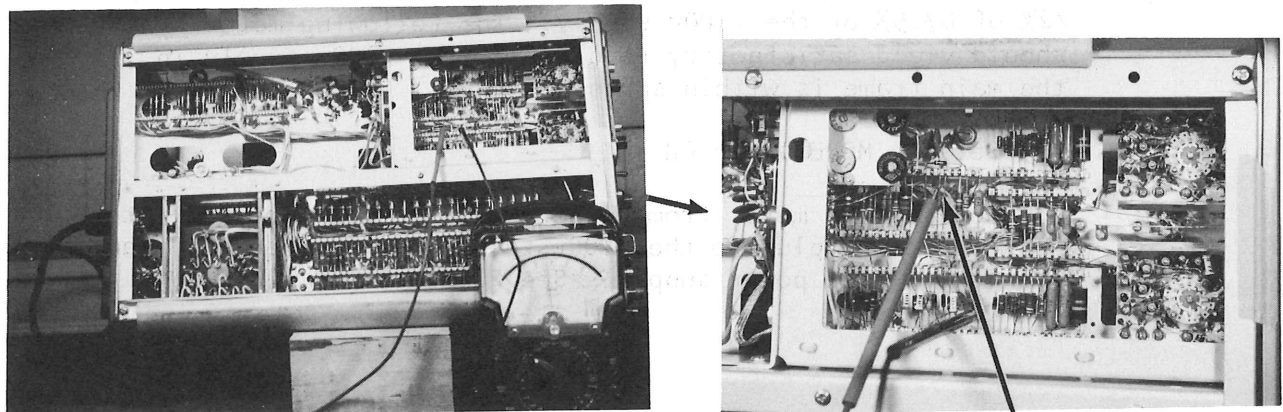

+10v supply monitored at the junction of R361 & R348

Figure 2

2. Adjust the +10 Volts pot, R396 - see Figure 3, for +10 v exactly.
 - a. Typical range of adjustment is from +5.5v to +11.5v (top end of range is dependent upon zener voltage).

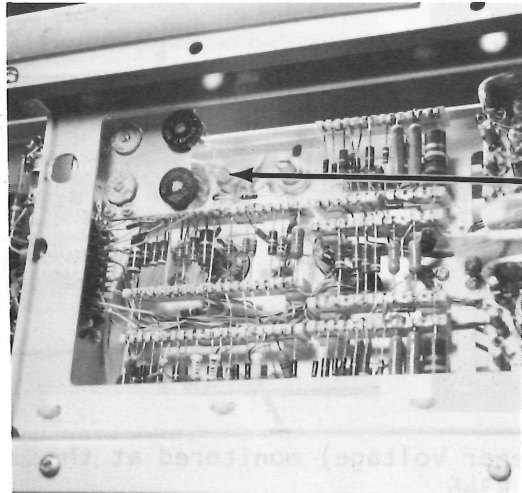

+10v adj.
R396

Figure 3

If a metal shafted alignment tool is used to set the +10 volts, the tool could make contact with the bare wire that is tied between R379 & R377 causing them to smoke which might anger the surgeon general.

II. OUTPUT DC LEVEL

The setting of the Output DC Level is dependent on the actual output voltage of the +100v supply in the scope main frame. The Output DC Level is specified as follows: within $\pm 2\%$ of 67.5% of the +100v supply. The following method should yield satisfactory results, if the +100v supply in the main frame is within specs.

- A. Set the MODE sw to CH 1.
- B. Connect the meter from either pin 1 or pin 3 of the inter-connecting plug to the +100v test point in the main frame low voltage power supply. See Figure 4.

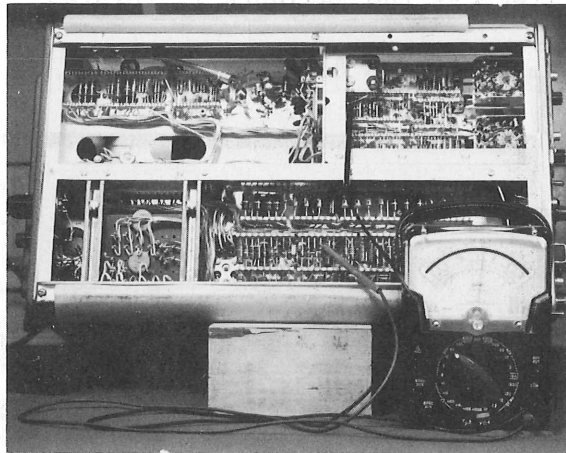
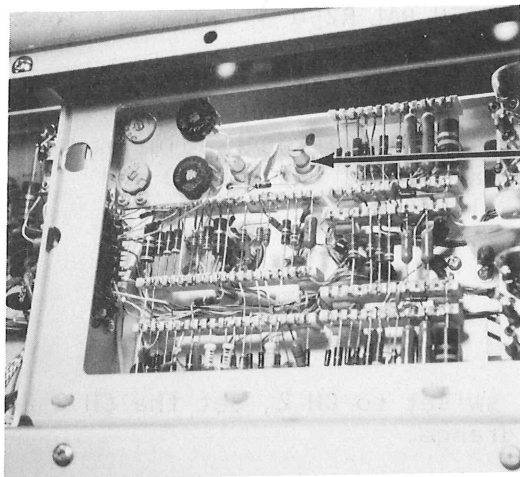

Figure 4

- C. Adjust the Output DC Level, R359 - see Figure 7, for exactly 32.5v.



Output DC Level
R359

Figure 5

- D. Set the MODE sw to ADD and note deviation
E. Disconnect the meter.

III. VAR ATTEN BAL

- A. CH 1 & CH 2

1. Set the MODE sw to ALT.

2. Adjust the VAR ATTEN BAL, R150 (R250) - see Figure 6, for no vertical shift of the CH 1 (CH 2) trace as the VARIABLE is rotated.

CH 1 VAR ATTEN BAL R150

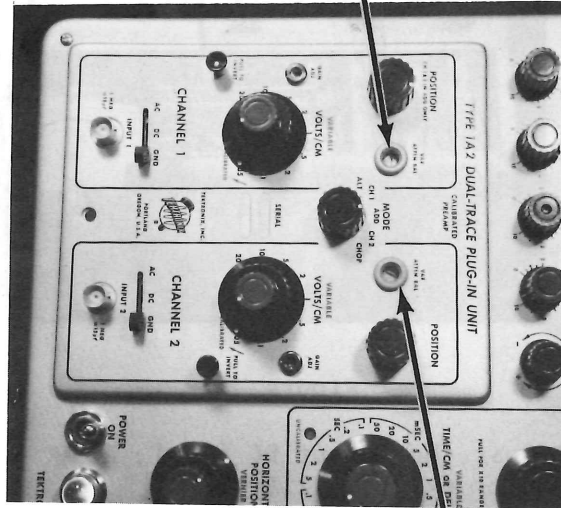

CH 2 VAR ATTEN BAL R250

Figure 6

3. The CH 1 and CH 2 VAR ATTEN BAL adjustments interact. Repeat step 2 until R150 and R250 are properly adjusted.

IV. NORM TO INVERT SHIFT

A. CH 2

1. With the MODE sw set to CH 2, set the CH 2 POSITION control to midrange.
2. Pull out the CH 2 PULL TO INVERT sw and check for less than 1 cm of trace shift.

B. CH 1

1. Set the MODE sw to CH 1 and set the CH 1 POSITION control to midrange.
2. Pull out the CH 1 PULL TO INVERT sw and check for less than 1 cm of trace shift.
3. Push in both PULL TO INVERT switches.

V. CH 1 TO ADD SHIFT

- A. Set the MODE sw to CH 1.
- B. Position the trace to the center of the graticule.
- C. Set the MODE sw to ADD and check for less than 2 cm of trace shift.

VI. ALT MODE and ALT SLAVE

A. ALT MODE

1. Set the MODE sw to ALT and position the traces about 2 cm apart.
2. Check alternate operation on all sweep speeds for A and B time bases.

B. ALT SLAVE (547 only)

1. Set the 547 HORIZONTAL DISPLAY to A ALT B and insure that CH 1 is displayed on A sweep.
2. Return the HORIZONTAL DISPLAY to B.

VII. CHOPPED MODE

A CHOP FREQUENCY

1. Set the MODE sw to CHOP, B TIME/CM to 5 μ sec, and with B TRIGGERING LEVEL control obtain a stable display.
2. Check for a chopped frequency of 220 KC \pm 20%.
 - a. 1 cycle/cm - 200 KC (-20%)
 - b. 1 cycle/.825 cm - 242 KC (+20%). See Figure 7.

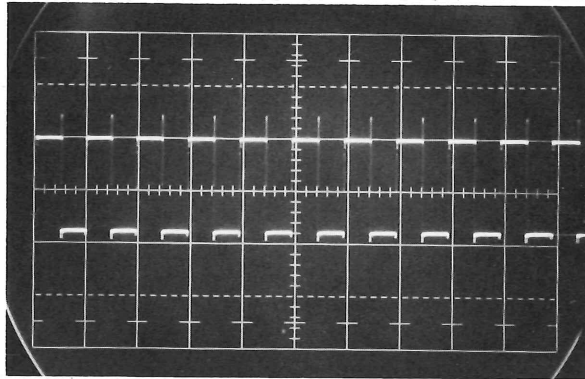

Check for a chopped frequency of $220 \text{ KC} \pm 20\%$

Figure 7

B. CHOPPED BLANKING AND DISTORTION

1. Set the CRT CATHODE SELECTOR (located on the back panel of the oscilloscope) to CHOPPED BLANKING. Check that the rising and falling portions of the chopped waveform are blanked. See Figure 8.

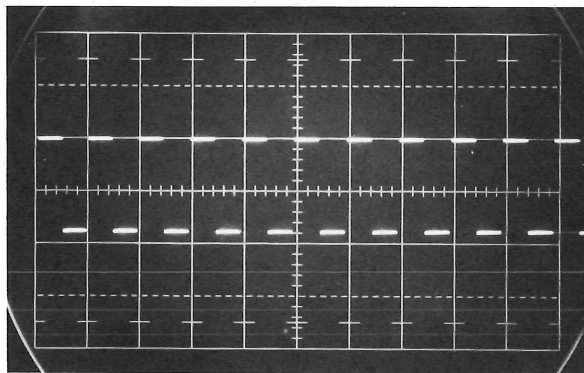

Check that the rising and falling portions of the chopped waveform are blanked and that the distortion is less than 1 mm.

Figure 8

2. Check the chopped waveform for less than 1 mm of distortion.
 - a. Distortion can also be checked with a free running sweep.
 - b. Both INPUT COUPLINGS must be set to GND to check distortion.
3. Return the CRT CATHODE SELECTOR to CRT CATHODE.

VIII. GAIN AND VARIABLE VOLTS/CM

A. CH 1

1. Set the MODE sw to CH 1 (CH 2), the INPUT COUPLING to DC, and B TIME/CM to 1 msec.
2. Apply .2v from the calibrator to CH 1 (CH 2) input connector. See Figure 9.

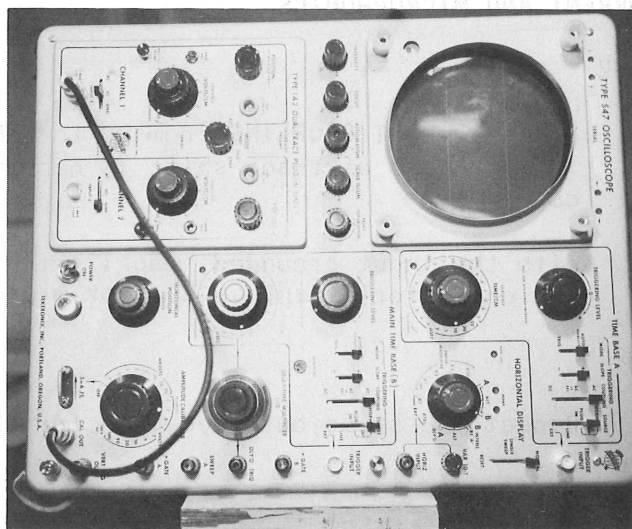

.2v from calibrator applied to CH 1 input connector.

Figure 9

3. Adjust the GAIN, R142 (R242) - see Figure 10, for exactly 4 cm of deflection.

CH 1 GAIN R142

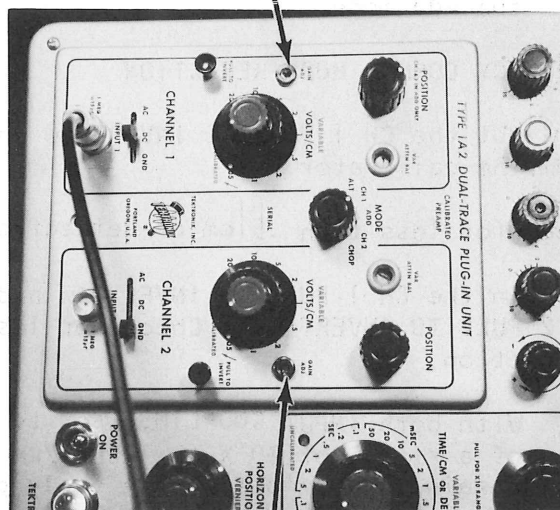

CH 2 GAIN R242

Figure 10

4. Rotate the VARIABLE fully CCW and check for 2.5:1 attenuation. (no more than 1.6 cm of deflection).
5. Return the VARIABLE to the CALIBRATED position (fully CW).

B. CH 2

1. Repeat the steps outlined in A for CH 2.

IX. GRID CURRENT AND MICROPHONICS

A. CH 2

1. Set the INPUT COUPLING from DC to GND and check for 1 mm or less of trace shift (5 nanoamps of grid current).
2. With the input grounded, rap lightly on side of scope and check for less than 2 mm of microphonics.

B. CH 1

1. Repeat the steps outlined in A for CH 1.

X. ADD

A. ADDED ALGEBRAICALLY

1. Set the MODE sw to ADD, both INPUT COUPLINGS TO AC, and apply .1v from the calibrator to both input connectors.
2. Check for 4 cm of deflection within $\pm .8$ mm.
 - a. Only the CH 1 POSITION control should operate in the ADD mode.

B. LOW FREQUENCY COMMON MODE REJECTION

1. Pull out the CH 1 PULL TO INVERT sw and apply .5v from the calibrator.
2. Check for less than .5 cm of deflection.
3. Push in the CH 1 PULL TO INVERT sw and pull out the CH 2 PULL TO INVERT sw. Check for less than .5 cm of deflection.
 - a. With both INPUT COUPLINGS set to AC, 20:1 rejection of a signal of 20 X the VOLTS/CM setting (1v) is obtained with most of the early phase C instruments.

- b. With both INPUT COUPLINGS set to DC, 20:1 rejection of a signal of 10 X the VOLTS/CM setting (.5v) is normal.

4. Push in the CH 2 PULL TO INVERT sw.

XI. VOLTS/CM ACCURACY

- A. Check the CH 1 and CH 2 VOLTS/CM sw accuracy against the following chart.

1. <u>VOLT/CM</u>	<u>AMPLITUDE CALIBRATOR</u>	<u>CM of DEFLECTION</u>
.05	.2	4 ± .8 mm
.1	.5	5 ± 1 mm
.2	1	5 ± 1 mm
.5	2	4 ± .8 mm
1	5	5 ± 1 mm
2	10	5 ± 1 mm
5	20	4 ± .8 mm
10	50	5 ± 1 mm
20	100	5 ± 1 mm

- a. If a dual input arrangement is used, the Input Coupling of the "off" channel should be set to GND.

XII. INPUT COMPENSATIONS

A. CH 1

1. Set the MODE sw to CH 1 (CH 2), the INPUT COUPLING to DC, and apply a signal from a 105 square wave generator to the CH 1 (CH 2) input connector.

- a. Connect the 105 to the 1A2 in the following manner:
105 - 50Ω cable - 50Ω terminator - 15 pf standardizer - input connector. See Figure 11.

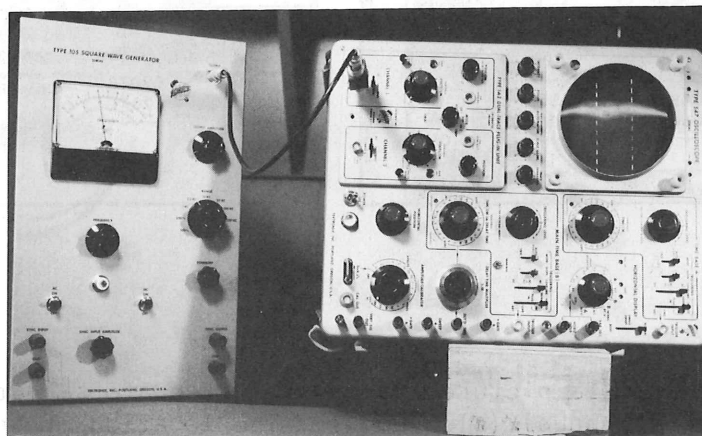

Figure 11

2. Set the 105 for an output frequency of 1 KC and set the AMPLITUDE control for 4 cm of deflection.
3. Using the following chart, adjust the CH 1 (CH 2) input compensations.

VOLTS/CM	CH 1		CH 2	
	SPIKE	LEVEL	SPIKE	LEVEL
.05		C104		C204
.1	C105C	C105B	C205C	C205B
.2	C106C	C106B	C206C	C206B
.5	C10 C	C107B	C207C	C207B
1.	C108C	C108B	C208C	C208B
2	C109C	C109B	C209C	C209B
5*	C110C	C110B	C210B	C210C
10	C111C	C111B	C211B	C211C
20	C112C	C112B	C212B	C212C

*Remove 50Ω terminator

See Figure 12 A and B and 13 A and B.

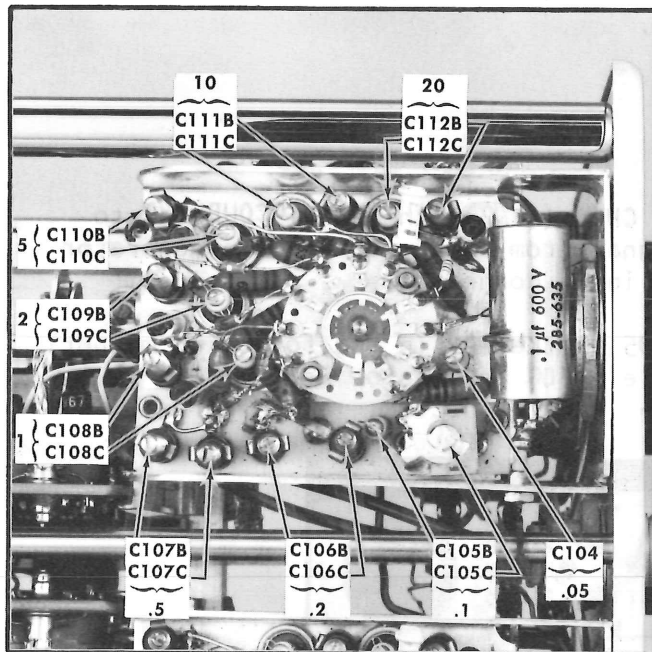

A

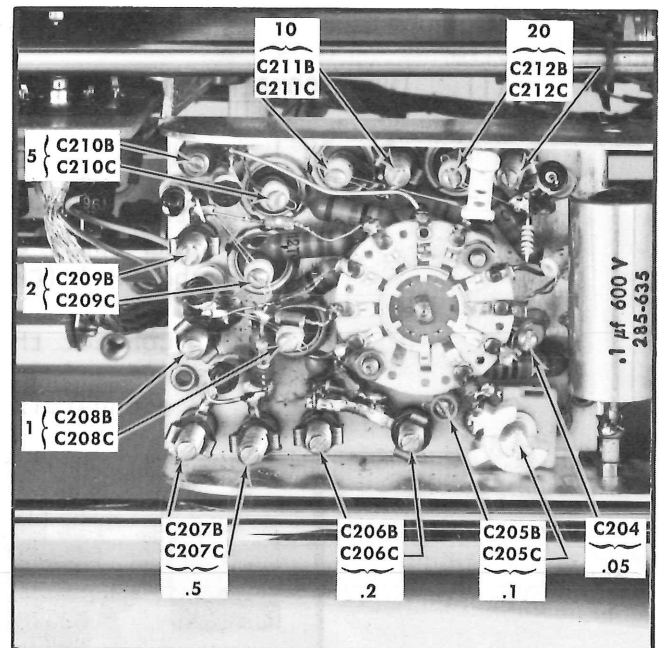

B

Figure 12

Figure 12 is a picture of the IAI attenuators that was used in the IAI Manual (blue book). The location of the adjustments is the same for the IA1 & IA2. Since we are not interested in the R & L values of the attenuator at this time and are only interested in adjustments, the IA1 picture is used.

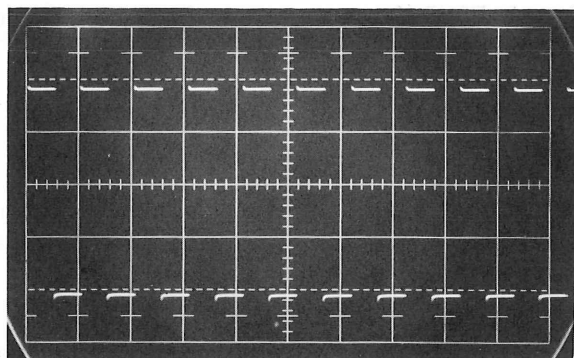

Note hook on compensated waveform at .05 position
Ignore hook and adjust for best flat top.

Figure 13 A

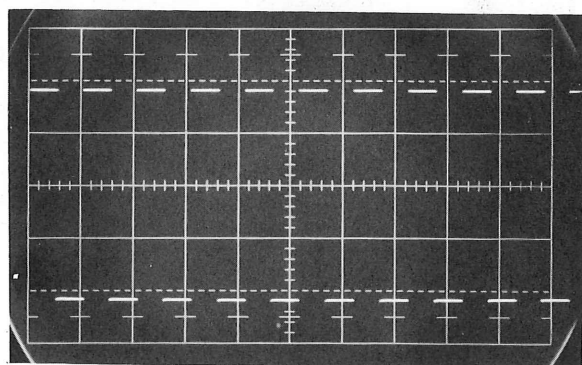

Hook tuned out by spike compensator (C106C) in
.1 position

Figure 13 B

B. CH 2

1. Repeat the steps outlined in A for CH 2.



XIII. HIGH FREQUENCY COMPENSATION

A. CH 2

1. Set B TIME/CM to $.1 \mu\text{sec}$, the INPUT COUPLING to AC, and set the 105 output frequency to 120 KC.
2. Connect a TU-5 to the 105 through a 105 to TU-5 adapter.
 - a. The connection should be made in the following manner: 105 - 105 to TU-5 adapter - 50Ω cable - TU-5 - 50Ω terminator - input connector. See Figure 14

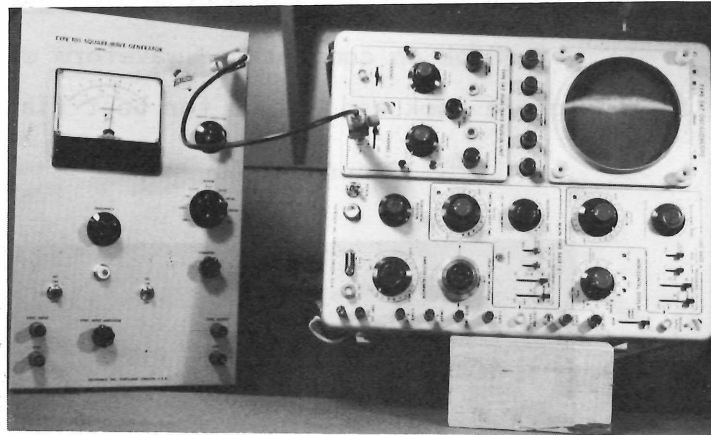
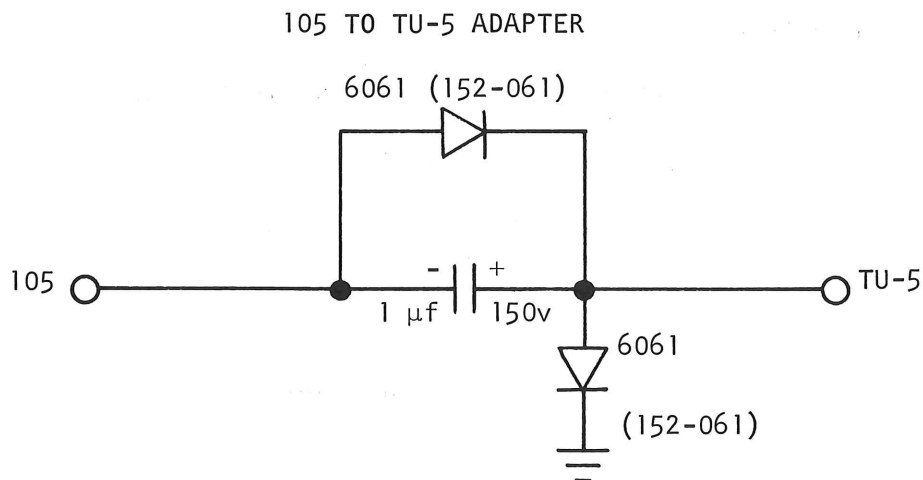
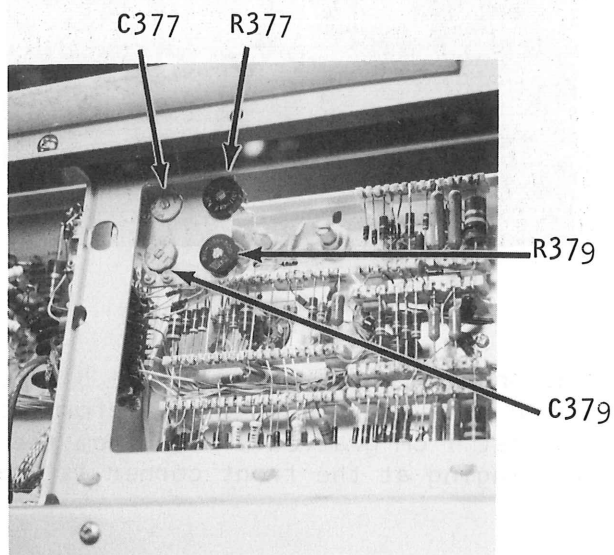

Figure 14

The 105 to TU-5 adapter is currently available from F.M.S. A schematic of the adapter is shown below for those who wish to make their own.



3. Set the TU-5 to the point where the fast rise waveform first appears. Obtain a stable display with the B TRIGGERING LEVEL control.
4. Obtain 4 cm of deflection with the VARIABLE control.
5. All the HF compensations are located on the bracket adjacent to the interconnecting plug. See Figure 15.



High Frequency Compensators

Figure 15

6. Adjust R377 so the front corner will not be affected as C377 is rotated through 360°.
 - a. If R377 is set to a low resistance, R377 and C377 can not be set for a 100 nanosec time constant.
7. Adjust R379 until a small dip appears just behind the front corner.
8. Adjust C379 for best front corner.
 - a. There may be some interaction between R379 and C379. Repeat steps 7 and 8 until the best front corner is achieved.

9. Adjust C377 for best flat top (R377 - usually does not have to be readjusted).
 - a. It may be helpful to set B TIME/CM to a slower range when adjusting for best flat top. Max. allowable aberration: 2% p-p. See Figure 16.

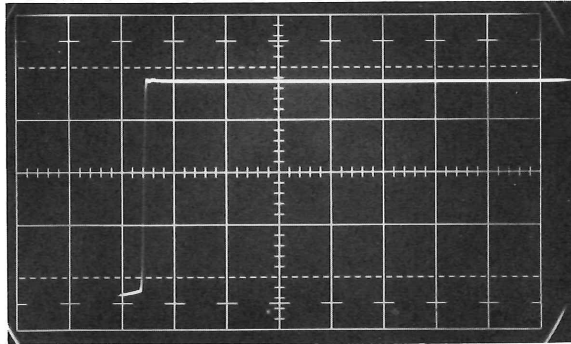

Figure 16

CH 2 response to a fast rise step. B TIME/CM is set at $.1 \mu\text{sec}$. If the top of the waveform is aligned with the 1st 1 cm graticule line from the top (dotted line), ringing at the front corner is exaggerated.

B. CH 1

1. Set the MODE sw to CH 1 and connect the TU-5 to the CH 1 input connector.
2. Set the INPUT COUPLING to AC and obtain 4 cm of deflection with the VARIABLE control.
3. Check HF compensation for max. aberration of 2% p-p. See Figure 17.

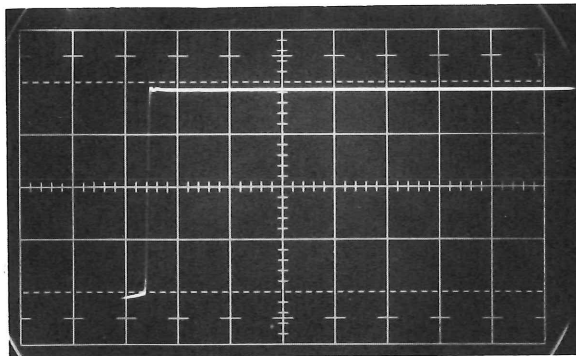

Figure 17

CH 1 response to a fast rise step.

- a. The high frequency compensators usually do not have to be readjusted for CH 2.
- b. Either CH 1 or CH 2 can be adjusted first and then the other channel can be checked.

NOTE: The HF compensations can be accomplished by driving the TU-5 with a 100v square wave from the calibrator. When the 547 vertical amplifier is driven by a fast rise step with a low repetition rate, the front corner tends to roll-off. See Figure 18.

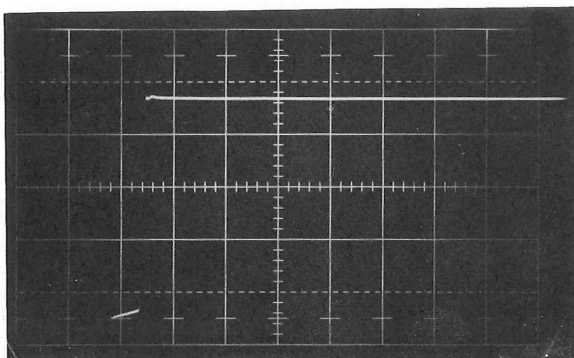

Figure 18

CH 2 shows a rolled-off response to a fast rise step with a low rep rate (1 KC). When making a comparison of this nature, it is important that the 2 displays be positioned at the same place on the CRT. As the display is positioned "down", the front corner of the 547 will roll-off and as the display is positioned "up", the front corner of the 547 will peak. (See 547 Training Package).

XIV. FREQUENCY RESPONSE

NOTE: A 190B with a 190B head (attenuator) should be used for this check. A 190A or a 190B with a 190A head will not give accurate results.

Even when a 190B head is used, complete accuracy can not be obtained. Recent evaluations in MSE have found that the output amplitude of the 190B will change under the following conditions:

The 190B with a 190B head is connected to a plug-in with an input C of 15 pf through a UHF to BNC adaptor. With the 190B head set at .5, the change in output amplitude from 50 KC to 50 MC is great enough to give an erroneous frequency response indication for a plug-in with a 50 MC passband.

The change in output amplitude is approximately equal to an increase in output frequency of 3 to 4 MC. Thus, if a plug-in and main frame vertical were tuned for a pass band of exactly 50 MC, the 3-db down frequency, as measured on the CRT, would appear to be about 46 to 47 MC, as indicated on the 190B's frequency selector. Therefore, a correction factor of 3 to 4 MC must be added to the frequency reading of the 190B to compensate for the change in amplitude.

A. CH 1

1. Leave the VARIABLE control at the same setting used in the previous step.
2. Connect a 190 B constant amplitude signal generator to the CH 1 input connector. See Figure 19.

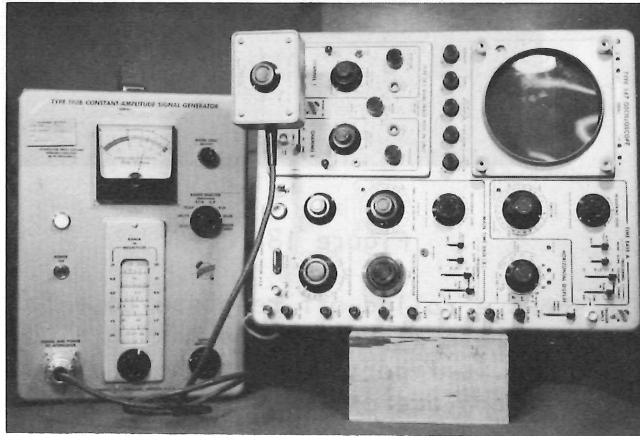

Figure 19

190B signal generator connected to the CH 1 input connector.

3. Set the output frequency of the 190B to 50 KC and obtain 4 cm of deflection with the ATTENUATOR and OUTPUT AMPLITUDE controls on the 190B.
4. Without changing the output amplitude, set the output frequency of the 190B to 50 MC and check for 2.8 cm of deflection. See Figure 20.

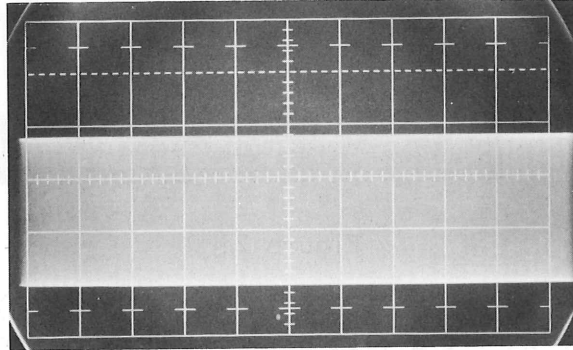
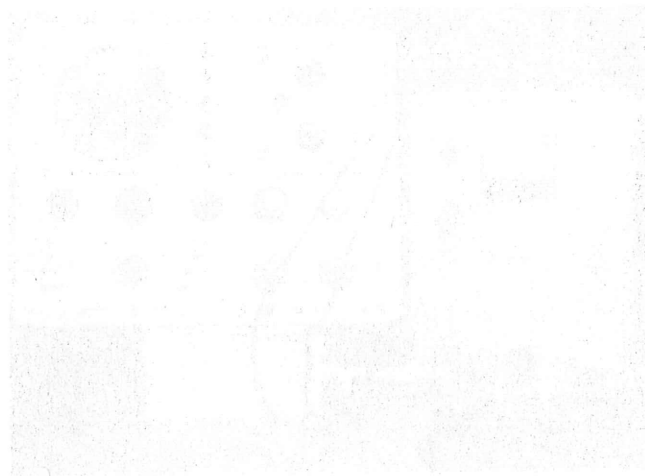

Figure 20

CH 1 response to 50 MC (3-db down). We came out just shy of 2.8 cm. When we add a correction factor of 3 to 4 MC to the frequency reading of the 190B, we find that we did make specs. Typical response of CH 1 and CH 2 is 55 MC, at the present time (MSE is evaluating the first phase C instruments).



B. CH 2 Repeat

1. Repeat the steps outlined in A for CH 2. See Figure 21.

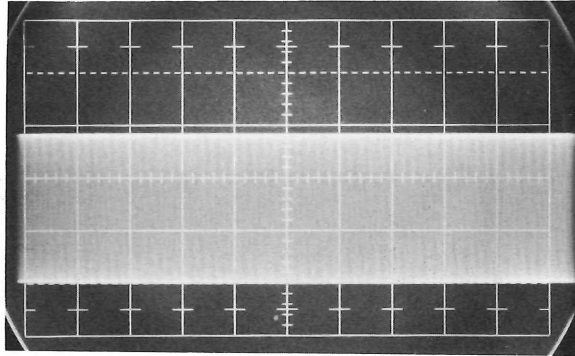

Figure 21

CH 2 response to 50 MC (3-db down).
We did a little better on this one, just
a skinch over 2.8cm.

XV. HIGH FREQUENCY COMMON MODE REJECTION

A. 50 MC COMMON MODE REJECTION

1. Return both VARIABLE controls to the CALIBRATED (fully CW) position.
2. Connect the 190B to both input connectors as shown in Figure 22.

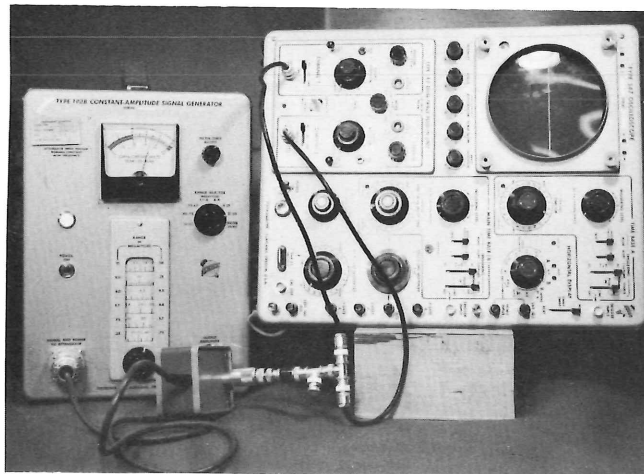

Figure 22

Proper lash-up for connecting 190B to both input connectors. It is especially important that both channels are connected through cables of equal length.

3. Set the CH 2 VOLTS/CM control to .1 and obtain 5 cm of deflection.
4. Return the CH 2 VOLTS/CM control to .05 and pull out the CH 2 PULL TO INVERT sw.
5. Set the MODE sw to ADD and check for less than .5 cm of deflection. See Figure 23.

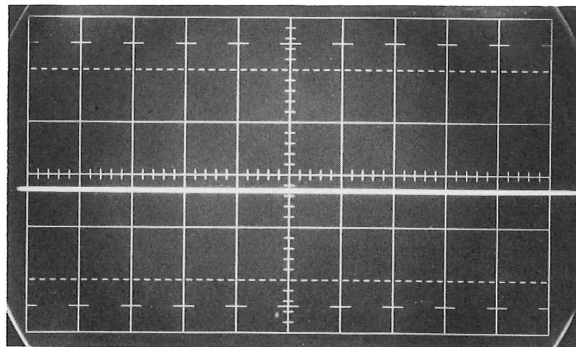
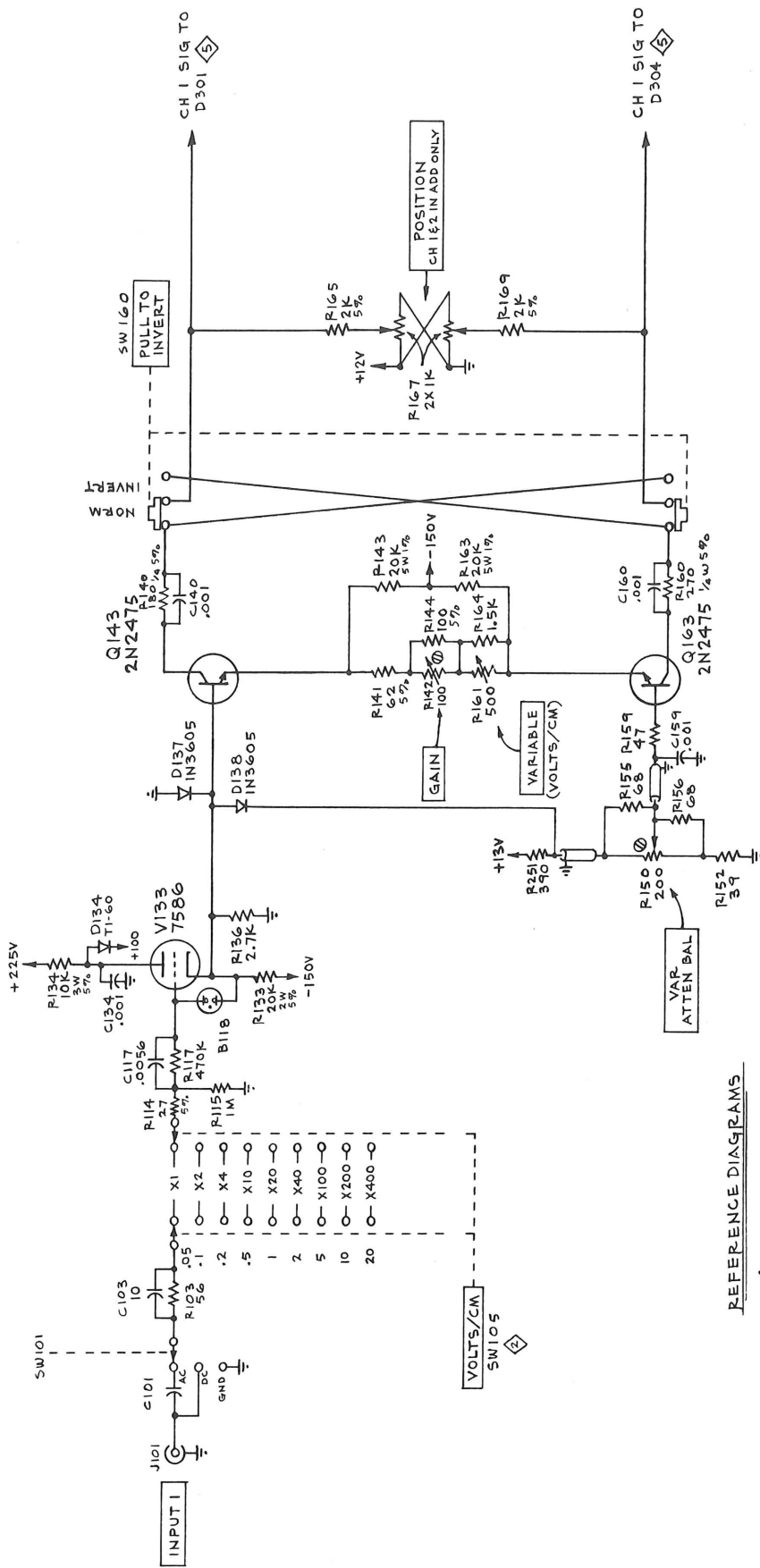

Figure 23

At present, the H.F. common mode rejection is not specified. Early phase C instruments are typically achieving a common mode rejection of 33:1. MSE is waiting for a run of about 100 production boxes before a permanent specification is made (approximately week 23). The tentative spec is 20:1.



REFERENCE DIAGRAMS

- ① CH 1 ATTENUATORS
- ② SWITCHING & OUTPUT AMPLIFIER

REVISED:
2-19-64
3-13-64

CHANNEL 1 INPUT AMPLIFIER
C-1A2-0015

GAB
1-31-64

TYPE 1A2 PLUG-IN

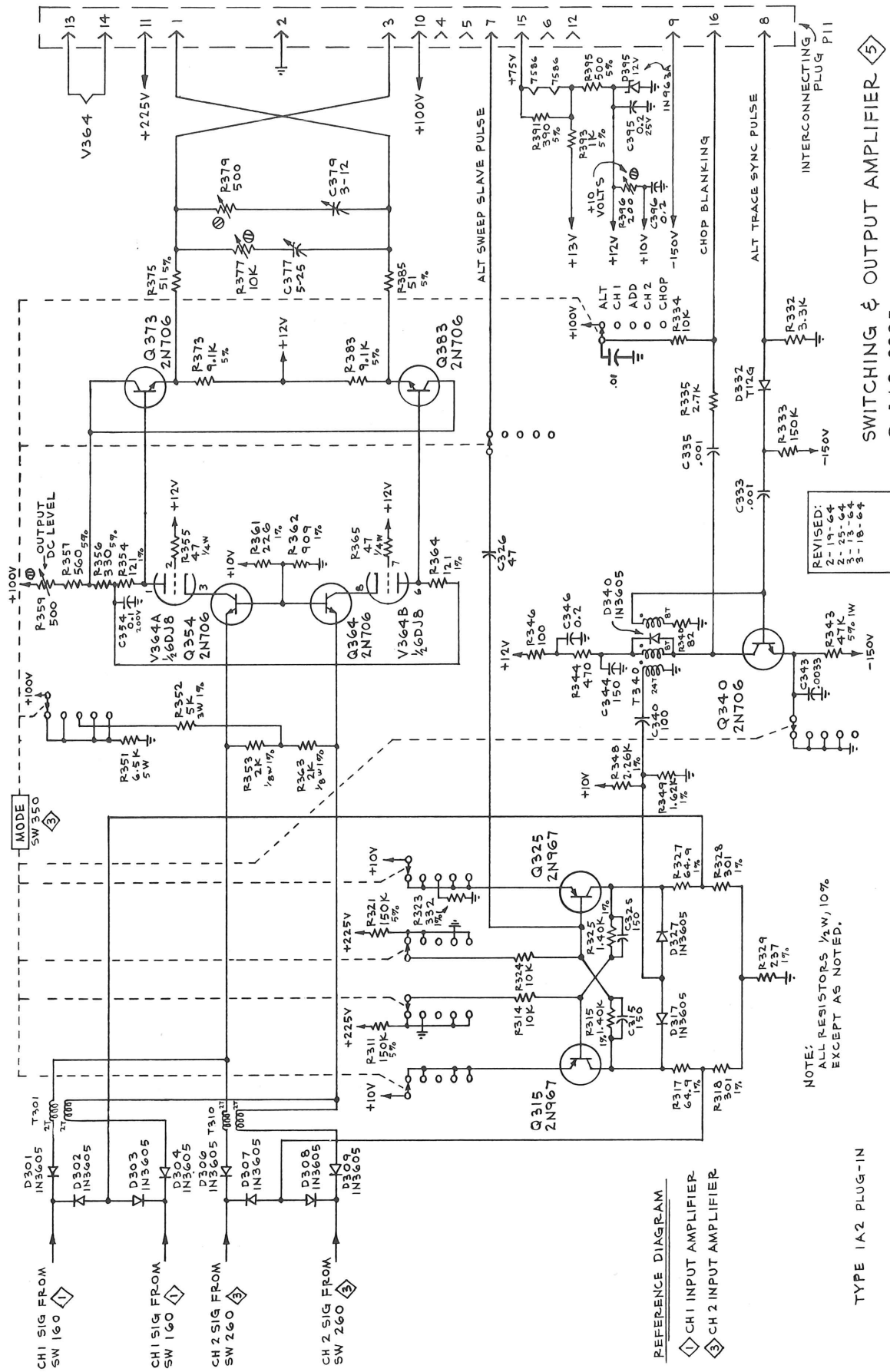

SWITCHING & OUTPUT AMPLIFIER
C-1A2-0025

REVISED:
2-19-64
2-25-64
3-13-64
3-18-64

NOTE:
ALL RESISTORS 1/2W, 10%
EXCEPT AS NOTED.

REFERENCE DIAGRAM
① CH 1 INPUT AMPLIFIER
② CH 2 INPUT AMPLIFIER

TYPE 1A2 PLUG-IN

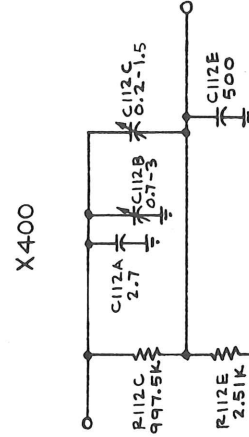
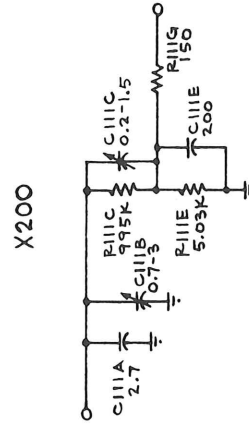
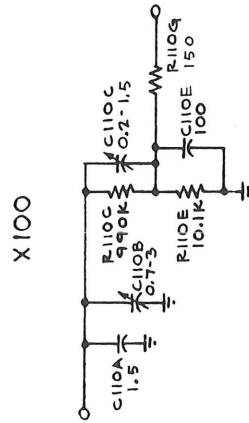
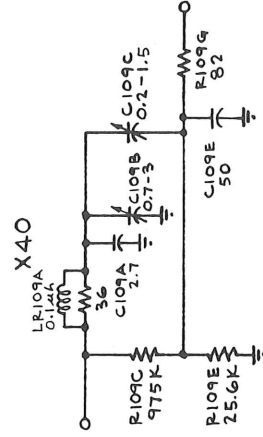
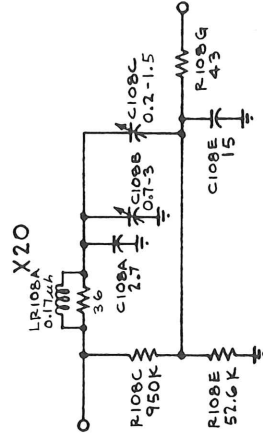
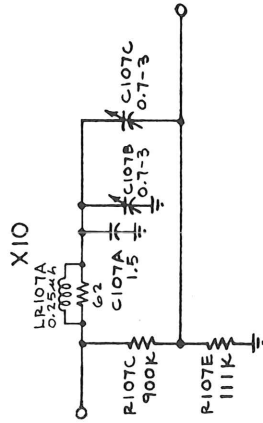
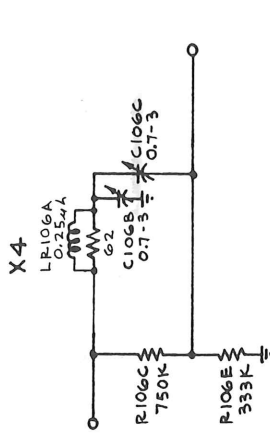
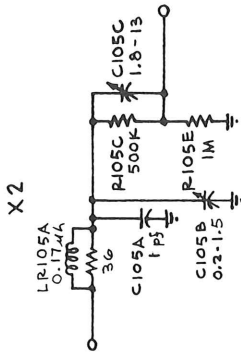
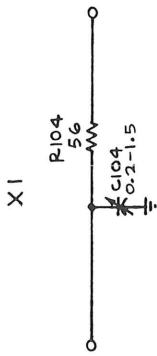

TYPE IA2 PLUG-IN

CHANNEL 1 ATTENUATORS
C-1A2-0005

SAB
2-20-64

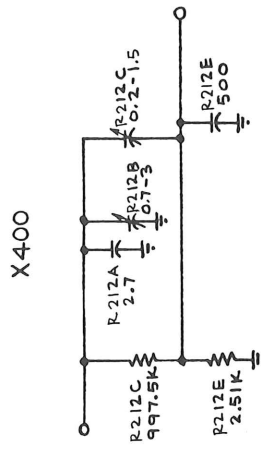
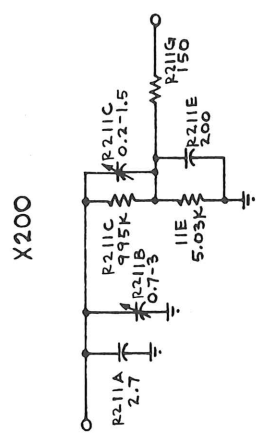
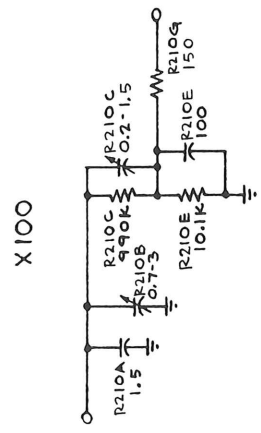
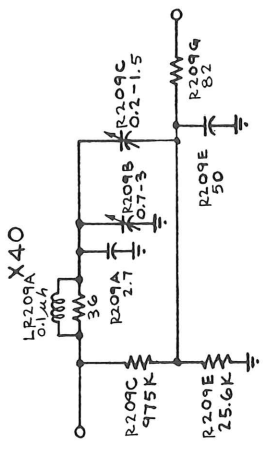
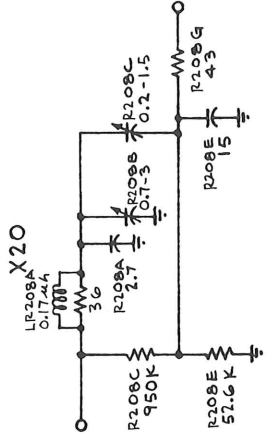
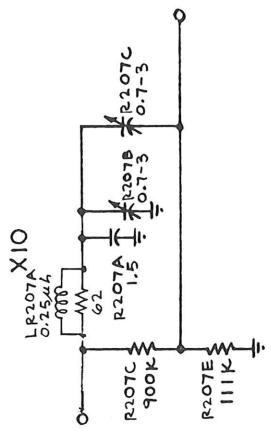
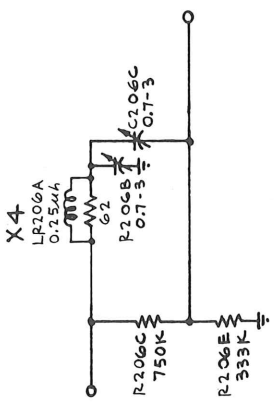
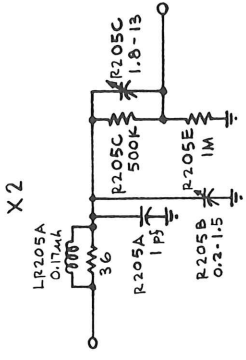
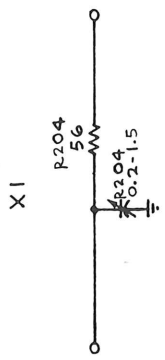

TYPE 1A2 PLUG-IN

CHANNEL 2 ATTENUATORS
C-1A2-0010

GAB
2-20-64

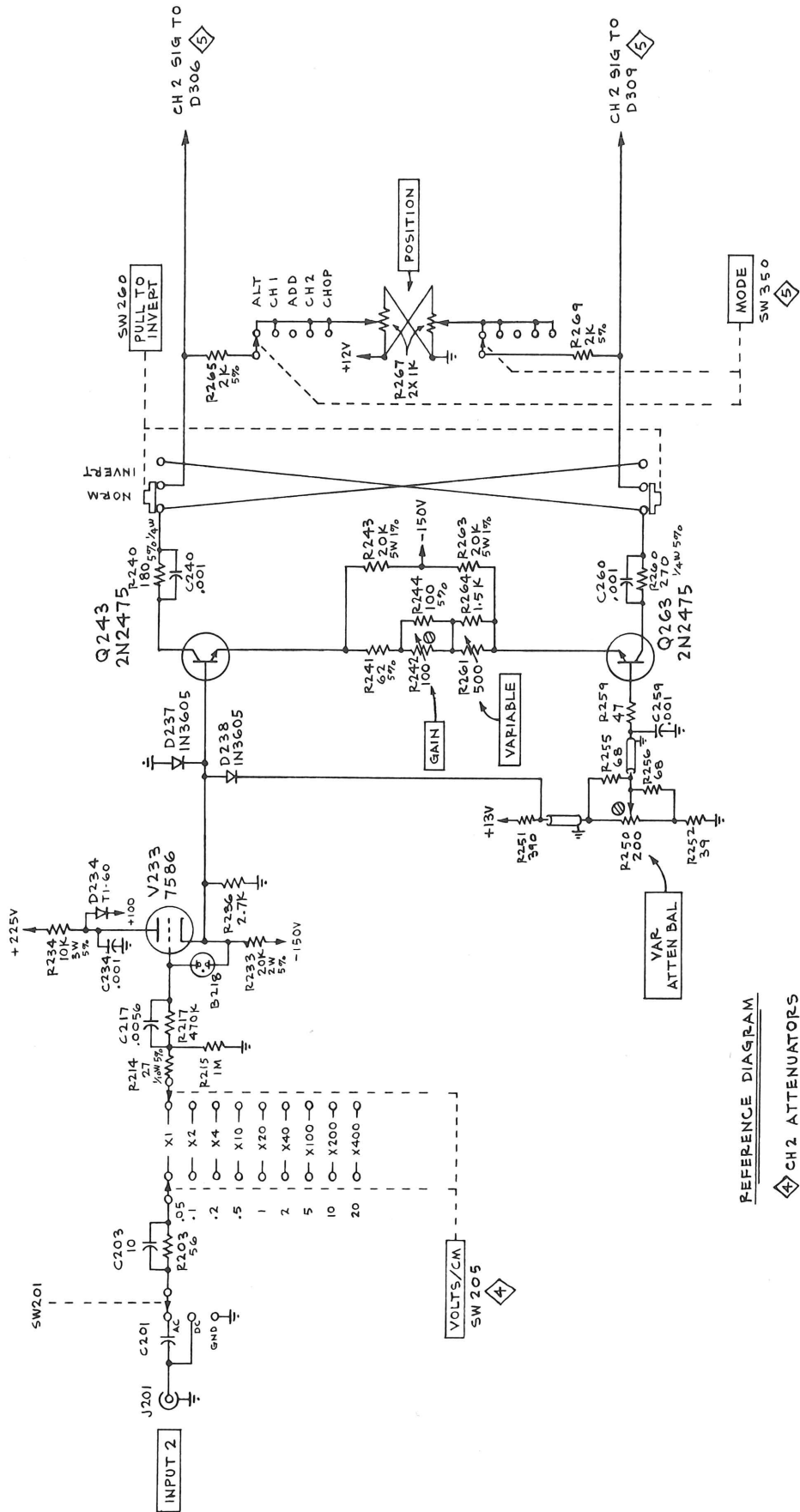

GAB
1-31-64

CHANNEL 2 INPUT AMPLIFIER 3
C-1A2-0020

REVISED:
2-19-64
3-13-64

REFERENCE DIAGRAM

- ④ CH 2 ATTENUATORS
- ⑤ SWITCHING & OUTPUT AMPLIFIER

TYPE 1A2 PLUG-IN

