



4345-1

P6460 data acquisition probe.

INTRODUCTION

The P6460 is a 100 MHz data acquisition probe suitable for use with the 1240/1241 Logic Analyzer 1240D1 and 1240D2 Acquisition Cards and the DAS 91A24 and 91AE24 Data Acquisition Modules. The P6460 has nine data channels and a clock line. When used with the DAS, one of the data channels serves as a clock qualifier.

The P6460 probe can also be used with the following DAS modules:

- 91S16/32 Pattern Generation Module
- 92A16/16E Data Acquisition Module
- 92S16/32 Pattern Generation Module

These Instructions contain the service information for this probe. For convenience, put a copy of them in the back of the

service manual for the logic analyzer that the probe will usually be used with.

Labels

Two labels are included with your probe. The one with an 8 in the upper left corner and a C/Q in the upper right corner is for use with 1240/1241 Logic Analyzer. The label with a Q in the upper left corner and a CK in the upper right corner is for use with DAS91A24 and 91AE24 Data Acquisition Modules.

Operator's Information

This manual contains primarily service information. For operator's information, refer to the operator's manual of the instrument that the probe is to be used with, either the *1240/1241 Logic Analyzer Operator's Manual* or the *DAS 9100 Series Operator's Manual*.

ACCESSORIES

Standard Accessories:

1 Instruction Sheet	070-4345-00
1 Lead Set, 10 inch	012-0747-00
1 Package of 12 Probe Tips (each tip is a 206-0222-00)	020-1386-00
2 Ground (or VL) Sense Leads, 5 inch with Pomona Hook Tips (344-0267-00)	012-0989-00
2 Alligator Clips (substitute for hook tips above)	344-0046-00

When ordering the P6460 for the 92A16 use the part number 010-6460-16. This insures you will receive the appropriate standard accessories for the 92A16/16E listed below.

010-6460-16 Standard Accessories:

1 Instruction Sheet	070-4345-00
1 Lead Set, 5 inch	012-0987-00
2 Ground VL Sense Leads, 5 inch with Pomona Hook Tips (344-0267-00)	012-0989-00
2 Alligator Clips (substitute for hook tips above)	344-0046-00

Optional Accessories:

Flying Lead Set, 5 inches long	012-0987-00
Flying Lead Set, 25 cm long	012-0800-00
40-pin Univ. Probe Intfc. Kit	020-1041-00
1240 Diagnostic Lead Set	198-5069-00
Diagnostic Lead Set, 10 inches long	012-1000-00
Package of 10 Ground (or VL) Sense Leads with Pomona Hook Tips (344-0267-00)	012-0989-01
GPIB Connector/Adapter	103-0209-00
IC Extractor, 16 pin	003-0709-00
Adapter, Test Clip, 16 DIP	015-0330-00
Adapter, Test Clip, 40 DIP, 10 cm cable (requires 380-0560-05 Adapter)	015-0339-02
Adapter, Test Clip, 40 DIP, 30 cm cable (requires 380-0560-05 Adapter)	015-0339-00
Adapter, required for use with 40 DIP Adapters	380-0560-05



4345-2

Standard accessories for the P6460.

GROUND CONNECTIONS AND FREQUENCY

For clock operating frequencies up to 25 MHz, the 10-inch lead sets (012-0747-00 or 012-0800-00) with one USER'S GND lead connected are sufficient.

For clock operating frequencies above 25 MHz but below 50 MHz, 10-inch lead sets may be used if both USER'S GND leads are connected.

For frequencies above 50 MHz and noisy environments, be sure to use the 5-inch lead sets (012-0987-00) and both USER'S GND leads with alligator clips.

SERVICE INFORMATION

WARNING

Disconnect power before removing protective coverings, soldering, or replacing components.

TEKTRONIX FIELD SERVICE

Service of Tektronix products is available from Tektronix Service Centers around the world. Contact your local sales or service organization for more information.

SPECIFICATIONS

Table 1
ELECTRICAL SPECIFICATIONS

Characteristic	Performance Requirements	Supplemental Information
MODULE-TO-PROBE SIGNALS Max. Operating Power Requirements		+5 V ($\pm 5\%$) at 600 mA when 20 output lines are terminated to +3 V through 60 Ω , at 300 mA when all output lines are unterminated
PROBE-TO-MODULE SIGNALS Data Channel Signal		Differential ECL Vcc = +5 V Vee = Gnd
User's Ground Sense		< 100 Ω to user's ground
Input Resistance	1 M Ω \pm 1%	
Input Capacitance		5 pF nominal
Max. Non-Destructive Input Voltage Range		\pm 40 V (DC + peak AC)
Max. Voltage Between Any Two Inputs		\pm 60 V (DC + peak AC)
Operating Input Voltage Range		From -40 V to input threshold's voltage + 10 V (+ 30 V for RS-232 only)
Threshold Offset and Accuracy		\pm 0.25% of threshold \pm 50 mV
Minimum Input Swing		0.5 V p-p centered on the threshold
Minimum Pulse Width (with input 250 mV over the threshold from + 0.5 V and - 0.5 V)		4 ns at threshold

**Table 2
ENVIRONMENTAL SPECIFICATIONS**

Characteristic	Description
Temperature Operating Storage	-15°C to +55°C -62°C to +75°C
Humidity	95% to 97% relative humidity
Altitude Operating Non-operating	4.5 km (15,000 ft.) 15 km (50,000 ft.)
Electrical Discharge	5 kV maximum from 200 pf with 2K Ω series resistance

STATIC PRECAUTIONS



Static discharge can damage any semiconductor in this instrument.

Observe the following precautions to avoid static damage:

1. Minimize handling of static-sensitive components.
2. Transport and store static-sensitive components or assemblies in their original containers, or on a metal rail, or on conductive foam. Label any package that contains static-sensitive components or assemblies.
3. Discharge the static voltage from your body by wearing a wrist strap while handling these components. Servicing static-sensitive assemblies should be performed only in a static-free work station by qualified service personnel.

**Table 3
PHYSICAL SPECIFICATIONS**

Characteristic	Description
Weight	12 oz.
Overall Dimensions	
Pod	4.5 in. long, 2.2 in. wide, 0.85 in. deep
Cable	78.75 in. (2 m) ± 10%

4. Nothing capable of generating or holding a static charge should be allowed on the work station surface.
5. Keep the component leads shorted together whenever possible.
6. Pick up components by the body, never by the leads.
7. Do not slide the components over any surface.
8. Avoid handling components in areas that have a floor or work-surface covering capable of generating a static charge.
9. Use a soldering iron that is connected to earth ground.
10. Use only special anti-static suction type or wick type desoldering tools.

NOTE

Damage to electrical components may not be immediately apparent. Always follow the precautionary measures listed above when handling static-sensitive components.

PERFORMANCE CHECK

Specification Checked

The input resistance of each channel should be $1\text{ M}\Omega \pm 1\%$.

Required Equipment

One digital multimeter with at least 0.2% accuracy at $1\text{ M}\Omega$. For example, the Tektronix DM 5010.

Procedure

1. With the probe disconnected, measure the resistance between the input to the channel you are checking and any other channel. Call this value R_a .

2. Next, measure the resistance between the input to the channel you want to measure and a third channel. Call this value R_b .

3. Finally, measure the resistance between the two other channels. Call this value R_c .

4. Calculate the value of the input resistance of the original channel using:

$$R_{input} = \frac{R_a + R_b - R_c}{2}$$

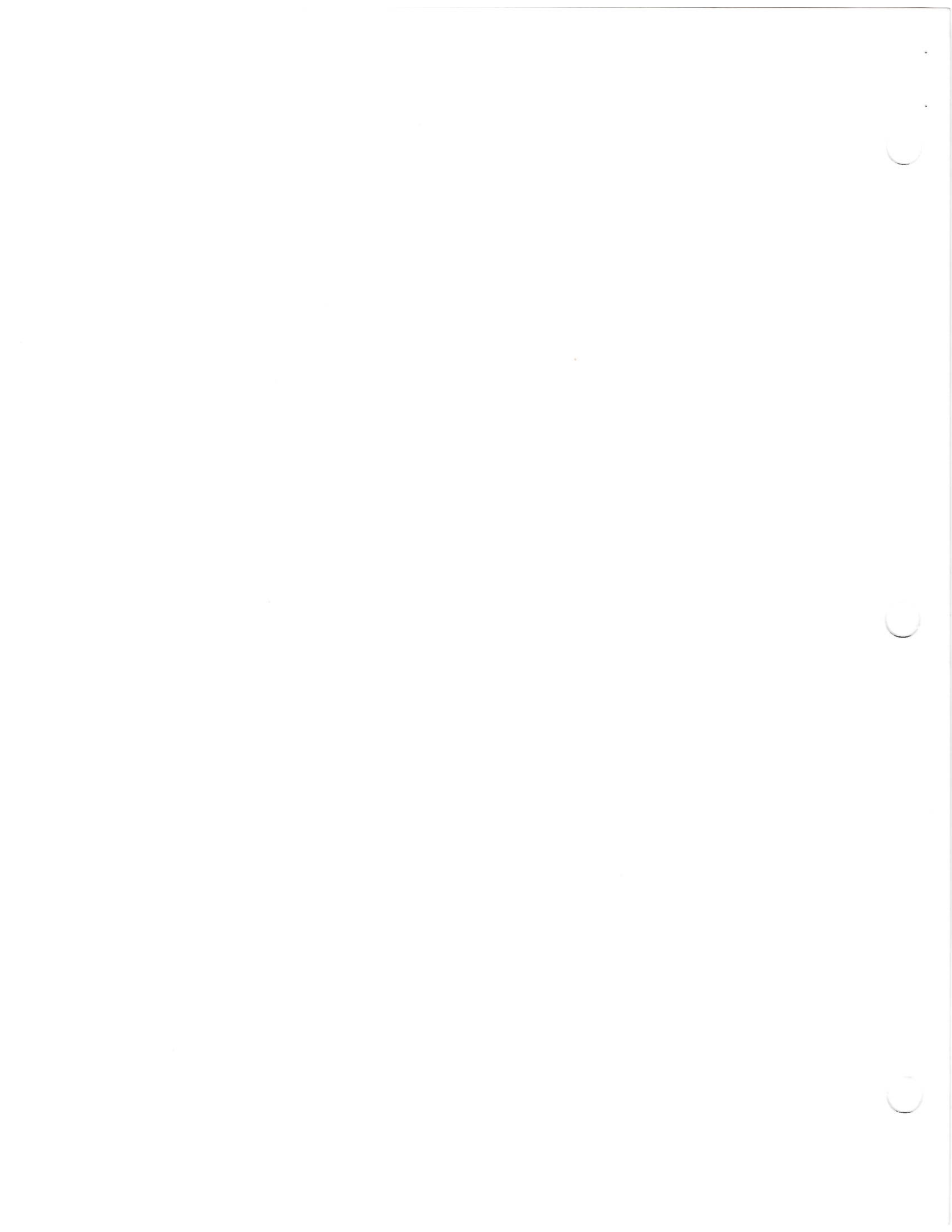

REPLACEABLE ELECTRICAL PARTS

PARTS ORDERING INFORMATION

Replacement parts are available from or through your local Tektronix, Inc. Field Office or representative.

Changes to Tektronix instruments are sometimes made to accommodate improved components as they become available, and to give you the benefit of the latest circuit improvements developed in our engineering department. It is therefore important, when ordering parts, to include the following information in your order: Part number, instrument type or number, serial number, and modification number if applicable.

If a part you have ordered has been replaced with a new or improved part, your local Tektronix, Inc. Field Office or representative will contact you concerning any change in part number.

Change information, if any, is located at the rear of this manual.

LIST OF ASSEMBLIES

A list of assemblies can be found at the beginning of the Electrical Parts List. The assemblies are listed in numerical order. When the complete component number of a part is known, this list will identify the assembly in which the part is located.

CROSS INDEX-MFR. CODE NUMBER TO MANUFACTURER

The Mfr. Code Number to Manufacturer index for the Electrical Parts List is located immediately after this page. The Cross Index provides codes, names and addresses of manufacturers of components listed in the Electrical Parts List.

ABBREVIATIONS

Abbreviations conform to American National Standard Y1.1.

COMPONENT NUMBER (column one of the Electrical Parts List)

A numbering method has been used to identify assemblies, subassemblies and parts. Examples of this numbering method and typical expansions are illustrated by the following:

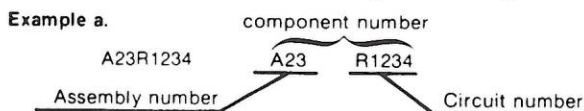

Read: Resistor 1234 of Assembly 23

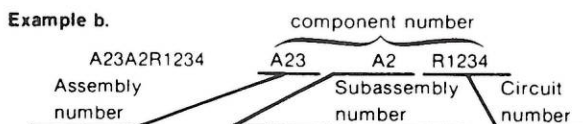

Read: Resistor 1234 of Subassembly 2 of Assembly 23

Only the circuit number will appear on the diagrams and circuit board illustrations. Each diagram and circuit board illustration is clearly marked with the assembly number. Assembly numbers are also marked on the mechanical exploded views located in the Mechanical Parts List. The component number is obtained by adding the assembly number prefix to the circuit number.

The Electrical Parts List is divided and arranged by assemblies in numerical sequence (e.g., assembly A1 with its subassemblies and parts, precedes assembly A2 with its subassemblies and parts).

Chassis-mounted parts have no assembly number prefix and are located at the end of the Electrical Parts List.

TEKTRONIX PART NO. (column two of the Electrical Parts List)

Indicates part number to be used when ordering replacement part from Tektronix.

SERIAL/MODEL NO. (columns three and four of the Electrical Parts List)

Column three (3) indicates the serial number at which the part was first used. Column four (4) indicates the serial number at which the part was removed. No serial number entered indicates part is good for all serial numbers.

NAME & DESCRIPTION (column five of the Electrical Parts List)

In the Parts List, an Item Name is separated from the description by a colon (:). Because of space limitations, an Item Name may sometimes appear as incomplete. For further Item Name identification, the U.S. Federal Cataloging Handbook H6-1 can be utilized where possible.

MFR. CODE (column six of the Electrical Parts List)

Indicates the code number of the actual manufacturer of the part. (Code to name and address cross reference can be found immediately after this page.)

MFR. PART NUMBER (column seven of the Electrical Parts List)

Indicates actual manufacturer's part number.

CROSS INDEX - MFR. CODE NUMBER TO MANUFACTURER

Mfr. Code	Manufacturer	Address	City, State, Zip Code
01121	ALLEN-BRADLEY CO	1201 SOUTH 2ND ST	MILWAUKEE WI 53204-2410
04222	AVX CERAMICS DIV OF AVX CORP	19TH AVE SOUTH P O BOX 867	MYRTLE BEACH SC 29577
07263	FAIRCHILD SEMICONDUCTOR CORP NORTH AMERICAN SALES SUB OF SCHLUMBERGER LTD MS 118	10400 RIDGEVIEW CT	CUPERTINO CAW CA 95014
19701	MEPCO/CENTRALAB A NORTH AMERICAN PHILIPS CO	P O BOX 760	MINERAL WELLS TX 76067-0760
22526	DU PONT E I DE NEMOURS AND CO INC DU PONT CONNECTOR SYSTEMS DIV MILITARY PRODUCTS GROUP	515 FISHING CREEK RD	NEW CUMBERLAND PA 17070-3007
24546	CORNING GLASS WORKS	550 HIGH ST	BRADFORD PA 16701-3737
27014	NATIONAL SEMICONDUCTOR CORP	2900 SEMICONDUCTOR DR	SANTA CLARA CA 95051-0606
80009	TEKTRONIX INC	4900 S W GRIFFITH DR P O BOX 500	BEAVERTON OR 97077
81073	GRAYHILL INC	561 HILLGROVE AVE PO BOX 10373	LA GRANGE IL 60525-5914

Component No.	Tektronix Part No.	Serial/Assembly No. Effective Dscont	Name & Description	Mfr. Code	Mfr. Part No.
A70	-----		CKT BOARD ASSY:MAIN (NOT REPLACEABLE-ORDER 672-1119-01)		
A70C104	283-0186-00		CAP,FXD,CER DI:27PF,5%,50V	04222	SR155A 270JAA
A70C121	283-0177-00		CAP,FXD,CER DI:1UF,+80-20%,25V	04222	SR302E105ZAATR
A70C122	283-0177-00		CAP,FXD,CER DI:1UF,+80-20%,25V	04222	SR302E105ZAATR
A70CR115	152-0333-00		SEMICONDC DVC,DI:SW,SI,55V,200MA,DO-35	07263	FDH-6012
A70J126	131-2615-00		CONN,RCPT,ELEC:CKT BD,RTANG,17/34 CONT,MALE	22526	65820-005
A70R106	317-0100-00		RES,FXD,CMPSN:10 OHM,5%,0.125W	01121	BB1005
A70R109	307-0706-00		RES NTWK,FXD,FI:4,10K OHM,2%,0.2W EA	01121	208B103
A70R221	321-0292-07		RES,FXD,FILM:10.7K OHM,0.1%,0.125W,TC=T9	24546	NE55E1072B
A70R222	321-0463-00		RES,FXD,FILM:649K OHM,1%,0.125W	19701	5033ED649KOF
A70R309	317-0151-00		RES,FXD,CMPSN:150 OHM,5%,0.125W	01121	BB1515
A70R313	317-0510-00		RES,FXD,CMPSN:51 OHM,5%,0.125W	01121	BB5105
A70U115	156-0625-01		MICROCKT,DGTL:8 BIT PRL LOAD SHIFT RGTR	27014	74C165NA+
A70W120	195-1715-00		LEAD,ELECTRICAL:26 AWG,2.5 L,9-2	80009	195-1715-00
CHASSIS PARTS					
DL319	175-1580-01		CABLE,SP,ELEC:26 AWG SOLID TWISTED PAIR	80009	175-1580-01
J100	131-1811-00		TERM SET,PIN:10,0.025 SQ ON 0.15 CTR	22526	65595-110
J135	196-0797-00		FLEX CIRCUIT:36 CONDUCTOR,COPPER	80009	196-0797-00
J200	131-1811-00		TERM SET,PIN:10,0.025 SQ ON 0.15 CTR	22526	65595-110
J300	131-1811-00		TERM SET,PIN:10,0.025 SQ ON 0.15 CTR	22526	65595-110
J301	131-1812-00		TERM SET,PIN:10,0.025 SQ ON 0.15 CTR	22526	65603-110
R104	317-0111-00		RES,FXD,CMPSN:110 OHM,5%,0.125W	01121	BB1115
R105	317-0111-00		RES,FXD,CMPSN:110 OHM,5%,0.125W	01121	BB1115
R107	317-0111-00		RES,FXD,CMPSN:110 OHM,5%,0.125W	01121	BB1115
R108	317-0111-00		RES,FXD,CMPSN:110 OHM,5%,0.125W	01121	BB1115
R204	317-0111-00		RES,FXD,CMPSN:110 OHM,5%,0.125W	01121	BB1115
R205	317-0111-00		RES,FXD,CMPSN:110 OHM,5%,0.125W	01121	BB1115
R208	317-0111-00		RES,FXD,CMPSN:110 OHM,5%,0.125W	01121	BB1115
R304	317-0111-00		RES,FXD,CMPSN:110 OHM,5%,0.125W	01121	BB1115
R306	317-0111-00		RES,FXD,CMPSN:110 OHM,5%,0.125W	01121	BB1115
R308	317-0111-00		RES,FXD,CMPSN:110 OHM,5%,0.125W	01121	BB1115
S100	260-0735-01		SWITCH,PUSH:T,NO CONTACT,BLACK BTN	81073	39-3
U302	-----		MICROCIRCUIT,DI:LOGIC ACQ CIRCUIT (NOT REPLACEABLE,ORDER 672-1119-01)		

REPLACEABLE MECHANICAL PARTS

PARTS ORDERING INFORMATION

Replacement parts are available from or through your local Tektronix, Inc. Field Office or representative.

Changes to Tektronix instruments are sometimes made to accommodate improved components as they become available, and to give you the benefit of the latest circuit improvements developed in our engineering department. It is therefore important, when ordering parts, to include the following information in your order: Part number, instrument type or number, serial number, and modification number if applicable.

If a part you have ordered has been replaced with a new or improved part, your local Tektronix, Inc. Field Office or representative will contact you concerning any change in part number.

Change information, if any, is located at the rear of this manual.

SPECIAL NOTES AND SYMBOLS

- X000 Part first added at this serial number
- 00X Part removed after this serial number

FIGURE AND INDEX NUMBERS

Items in this section are referenced by figure and index numbers to the illustrations.

INDENTATION SYSTEM

This mechanical parts list is indented to indicate item relationships. Following is an example of the indentation system used in the description column.

- ```

1 2 3 4 5 Name & Description
Assembly and/or Component
Attaching parts for Assembly and/or Component
 --- * ---
Detail Part of Assembly and/or Component
Attaching parts for Detail Part
 --- * ---
Parts of Detail Part
Attaching parts for Parts of Detail Part
 --- * ---

```

Attaching Parts always appear in the same indentation as the item it mounts, while the detail parts are indented to the right. Indented items are part of, and included with, the next higher indentation. The separation symbol --- \* --- indicates the end of attaching parts.

**Attaching parts must be purchased separately, unless otherwise specified.**

## ITEM NAME

In the Parts List, an Item Name is separated from the description by a colon (:). Because of space limitations, an Item Name may sometimes appear as incomplete. For further Item Name identification, the U.S. Federal Cataloging Handbook H6-1 can be utilized where possible.

## ABBREVIATIONS

|       |                    |         |                       |          |                      |          |                 |
|-------|--------------------|---------|-----------------------|----------|----------------------|----------|-----------------|
| "     | INCH               | ELCTRN  | ELECTRON              | IN       | INCH                 | SE       | SINGLE END      |
| #     | NUMBER SIZE        | ELEC    | ELECTRICAL            | INCAND   | INCANDESCENT         | SECT     | SECTION         |
| ACTR  | ACTUATOR           | ELCTLT  | ELECTROLYTIC          | INSUL    | INSULATOR            | SEMICOND | SEMICONDUCTOR   |
| ADPTR | ADAPTER            | ELEM    | ELEMENT               | INTL     | INTERNAL             | SHLD     | SHIELD          |
| ALIGN | ALIGNMENT          | EPL     | ELECTRICAL PARTS LIST | LPHLDR   | LAMPHOLDER           | SHLDR    | SHOULDERED      |
| AL    | ALUMINUM           | EQPT    | EQUIPMENT             | MACH     | MACHINE              | SKT      | SOCKET          |
| ASSEM | ASSEMBLED          | EXT     | EXTERNAL              | MECH     | MECHANICAL           | SL       | SLIDE           |
| ASSY  | ASSEMBLY           | FIL     | FILLISTER HEAD        | MTG      | MOUNTING             | SLFLKG   | SELF-LOCKING    |
| ATTEN | ATTENUATOR         | FLEX    | FLEXIBLE              | NIP      | NIPPLE               | SLVG     | SLEEVING        |
| AWG   | AMERICAN WIRE GAGE | FLH     | FLAT HEAD             | NON WIRE | NOT WIRE WOUND       | SPR      | SPRING          |
| BD    | BOARD              | FLTR    | FILTER                | OBD      | ORDER BY DESCRIPTION | SQ       | SQUARE          |
| BRKT  | BRACKET            | FR      | FRAME or FRONT        | OD       | OUTSIDE DIAMETER     | SST      | STAINLESS STEEL |
| BRS   | BRASS              | FSTNR   | FASTENER              | OVH      | OVAL HEAD            | STL      | STEEL           |
| BRZ   | BRONZE             | FT      | FOOT                  | PH BRZ   | PHOSPHOR BRONZE      | SW       | SWITCH          |
| BSHG  | BUSHING            | FXD     | FIXED                 | PL       | PLAIN or PLATE       | T        | TUBE            |
| CAB   | CABINET            | GSKT    | GASKET                | PLSTC    | PLASTIC              | TERM     | TERMINAL        |
| CAP   | CAPACITOR          | HDL     | HANDLE                | PN       | PART NUMBER          | THD      | THREAD          |
| CER   | CERAMIC            | HEX     | HEXAGON               | PNH      | PAN HEAD             | THK      | THICK           |
| CHAS  | CHASSIS            | HEX HD  | HEXAGONAL HEAD        | PWR      | POWER                | TNSN     | TENSION         |
| CKT   | CIRCUIT            | HEX SOC | HEXAGONAL SOCKET      | RCPT     | RECEPTACLE           | TPG      | TAPPING         |
| COMP  | COMPOSITION        | HLCPS   | HELICAL COMPRESSION   | RES      | RESISTOR             | TRH      | TRUSS HEAD      |
| CONN  | CONNECTOR          | HLEXT   | HELICAL EXTENSION     | RGD      | RIGID                | V        | VOLTAGE         |
| COV   | COVER              | HV      | HIGH VOLTAGE          | RLF      | RELIEF               | VAR      | VARIABLE        |
| CPLG  | COUPLING           | IC      | INTEGRATED CIRCUIT    | RTNR     | RETAINER             | W        | WITH            |
| CRT   | CATHODE RAY TUBE   | ID      | INSIDE DIAMETER       | SCH      | SOCKET HEAD          | WSHR     | WASHER          |
| DEG   | DEGREE             | IDENT   | IDENTIFICATION        | SCOPE    | OSCILLOSCOPE         | XFMR     | TRANSFORMER     |
| DWR   | DRAWER             | IMPLR   | IMPELLER              | SCR      | SCREW                | XSTR     | TRANSISTOR      |

CROSS INDEX - MFR. CODE NUMBER TO MANUFACTURER

| Mfr. Code | Manufacturer                             | Address                                        | City, State, Zip Code     |
|-----------|------------------------------------------|------------------------------------------------|---------------------------|
| 06383     | PANDUIT CORP                             | 17301 RIDGELAND                                | TINLEY PARK IL 07094-2917 |
| 73743     | FISCHER SPECIAL MFG CO                   | 111 INDUSTRIAL RD                              | COLD SPRING KY 41076-9749 |
| 77900     | SHAKEPROOF<br>DIV OF ILLINOIS TOOL WORKS | SAINT CHARLES RD                               | ELGIN IL 60120            |
| 80009     | TEKTRONIX INC                            | 14150 SW KARL BRAUM DR<br>PO BOX 500 MS 53-111 | BEAVERTON OR 97077        |
| TK1148    | ACACIA SALES INC (DIST)                  | 7763 SW CIRRRUS DR<br>BLDG 26                  | BEAVERTON OR 97005-6452   |
| TK1319    | MORELLIS Q & D PLASTICS                  | 1812 16-TH AVE                                 | FOREST GROVE OR 97116     |
| TK1374    | TRI-TEC ENGINEERING CORP                 | 13130 S NORMANDIE                              | GARDENA CA 90249-2128     |
| TK1415    | CABOT CORP<br>E.A.R. DIV                 | 7911 ZIONSVILLE RD                             | INDIANAPOLIS IN 46268     |

| Fig. &<br>Index<br>No. | Tektronix<br>Part No. | Serial/Assembly No. |         | Qty | 12345 Name & Description                                        | Mfr.   |                  |
|------------------------|-----------------------|---------------------|---------|-----|-----------------------------------------------------------------|--------|------------------|
|                        |                       | Effective           | Dscont  |     |                                                                 | Code   | Mfr. Part No.    |
| 1-                     | -----                 |                     |         | 1   | P6460:PROBE,DATA ACQ                                            |        |                  |
| -1                     | 334-4855-00           |                     |         | 1   | .MARKER,IDENT:MKD DIAGNOSTIC                                    | 80009  | 334-4855-00      |
| -2                     | 380-0711-00           |                     |         | 1   | .HOUSING,PROBE:UPPER,PC                                         | 80009  | 380-0711-00      |
| -3                     | 348-0390-00           |                     |         | 1   | .CUSHION,PROBE:1.5 X 2.0 X 0.125                                | TK1415 | ORDER BY DESCR   |
| -4                     | 380-0710-00           |                     |         | 1   | .HOUSING,PROBE:LOWER,PC<br>.(ATTACHING PARTS)                   | 80009  | 380-0710-00      |
| -5                     | 211-0086-00           |                     |         | 4   | .SCREW,MACHINE:4-40 X 0.75,FLH,100 DEG,STL                      | 80009  | 211-0086-00      |
| -6                     | 210-0406-00           |                     |         | 4   | .NUT,PLAIN,HEX:4-40 X 0.188,BRS CD PL<br>.(END ATTACHING PARTS) | 73743  | 12161-50         |
| -7                     | 200-2731-00           |                     |         | 2   | .COVER,HOLE:POLYCARBONATE,GRAY                                  | 80009  | 200-2731-00      |
| -8                     | 175-6807-00           | B010100             | B036539 | 1   | .CA ASSY,PROBE:2 METERS                                         | TK1374 | ORDER BY DESCR   |
|                        | 175-9843-00           | B036540             |         | 1   | .CA ASSY,SP,ELEC:22,28 AWG,76.0 L                               | TK1374 | ORDER BY DESCR   |
|                        | 672-1119-01           |                     |         | 1   | .CIRCUIT BD ASSY:MAIN                                           | 80009  | 672-1119-01      |
| -9                     | -----                 |                     |         | 1   | ..SWITCH,PUSH:(SEE S100 REPL)<br>..(ATTACHING PARTS)            |        |                  |
| -10                    | 358-0660-00           |                     |         | 1   | ..BUSHING,SW MTG:AL                                             | 80009  | 358-0660-00      |
| -11                    | 210-0008-00           |                     |         | 1   | ..WASHER,LOCK:#8 INTL,0.02 THK,STL<br>..(END ATTACHING PARTS)   | 77900  | 1208-00-00-0541C |
| -12                    | 358-0674-00           |                     |         | 1   | ..STRAIN RLF,CA:LOWER                                           | 80009  | 358-0674-00      |
| -13                    | 358-0675-00           |                     |         | 1   | ..STRAIN RLF,CA:UPPER                                           | 80009  | 358-0675-00      |
| -14                    | 361-0758-01           |                     |         | 1   | ..SPACER,PROBE:ACETAL SLATE GRAY                                | 80009  | 361-0758-01      |
| -15                    | -----                 |                     |         | 1   | ..TERM SET,PIN:(SEE J100,J200,J300 REPL)                        |        |                  |
| -16                    | 348-0782-00           |                     |         | 2   | ..CUSHION,HYBRID:SILCON SPONGE                                  | 80009  | 348-0782-00      |
| -17                    | -----                 |                     |         | 1   | ..TERM SET,PIN:(SEE J301 REPL)                                  |        |                  |
| -18                    | 346-0120-00           |                     |         | 2   | ..STRAP,TIEDOWN,E:5.5 L MIN,PLASTIC                             | 06383  | SST1.5M          |
| -19                    | 343-1095-00           |                     |         | 1   | ..CLAMP,HYB CKT:0.295 ID,ALUMINUM                               | 80009  | 343-1095-00      |
| -20                    | 426-1985-00           |                     |         | 1   | ..FRAME,WINDOW:                                                 | 80009  | 426-1985-00      |
| -21                    | 386-5017-00           |                     |         | 1   | ..PLATE,PRESSURE:                                               | TK1319 | 386-5017-00      |
| -22                    | 343-1094-00           |                     |         | 1   | ..RETAINER,CONN:SILICONE FOAM                                   | TK1319 | ORDER BY DESCR   |
| -23                    | 196-0797-00           |                     |         | 1   | ..FLEX CIRCUIT:36 CONDUCTOR,COPPER                              | 80009  | 196-0797-00      |
| -24                    | -----                 |                     |         | 1   | ..CKT BOARD ASSY:MAIN(SEE A70 REPL)                             |        |                  |
| -25                    | -----                 |                     |         | 1   | ...CONN,RCPT,ELEC:(SEE A70J126 REPL)                            |        |                  |



| Fig. & Index No.     | Tektronix Part No. | Serial/Assembly No. Effective | Dscont  | Qty | 12345 Name & Description                                               | Mfr. Code | Mfr. Part No.   |
|----------------------|--------------------|-------------------------------|---------|-----|------------------------------------------------------------------------|-----------|-----------------|
| 2-                   |                    |                               |         |     |                                                                        |           |                 |
| STANDARD ACCESSORIES |                    |                               |         |     |                                                                        |           |                 |
|                      | 070-4345-00        |                               |         | 1   | SHEET, TECHNICAL: INSTR, 010-6460-00                                   | 80009     | 070-4345-00     |
|                      | 020-0720-00        | B010100                       | B035539 | 1   | ACCESSORY KIT: PKG OF 12, 206-0222-00                                  | 80009     | 020-0720-00     |
|                      | 020-1386-00        | B035540                       |         | 1   | ACCESSORY KIT: PACKAGE OF 12(013-0217-00)                              | 80009     | 020-1386-00     |
|                      | 012-0747-00        |                               |         | 1   | LEAD SET, ELEC: 10 WIDE, 25 CML                                        | 80009     | 012-0747-00     |
|                      | 012-0989-00        |                               |         | 2   | LEAD SET, ELEC: GROUND OR VL SENSE LEAD 4.0 L<br>, BLACK W/PAMONA CLIP | 80009     | 012-0989-00     |
|                      | 334-4854-00        |                               |         | 1   | MARKER, IDENT: MKD DATA ACQUISITION PROBE                              | 80009     | 334-4854-00     |
|                      | 334-4856-00        |                               |         | 1   | MARKER, IDENT: MKD P6460 ACQUISITION PROBE                             | 80009     | 334-4856-00     |
|                      | 344-0046-00        |                               |         | 2   | CLIP, ELECTRICAL: ALLIGATOR, 1.56 L, STL BRT                           | 80009     | 344-0046-00     |
| OPTIONAL ACCESSORIES |                    |                               |         |     |                                                                        |           |                 |
|                      | 003-0709-00        |                               |         | 1   | EXTRACTOR, 1C: 16 PIN TEST CLIP                                        | 80009     | 003-0709-00     |
|                      | 012-0556-00        |                               |         | 1   | LEAD SET, ELEC: DIAGNOSTIC                                             | TK1148    | ASI 61500 REV A |
|                      | 012-0800-00        |                               |         | 1   | LEAD SET, ELEC: 10. WIDE, 9.843 L                                      | 80009     | 012-0800-00     |
|                      | 012-0987-00        |                               |         | 1   | LEAD SET, ELEC: 10 WIDE, 5.0 L                                         | 80009     | 012-0987-00     |
|                      | 012-0989-01        |                               |         | 1   | LEAD SET, ELEC: GROUND OR VL SENSE LEAD 4.0 L<br>, BLACK W/PAMONA CLIP | 80009     | 012-0989-01     |
|                      | 012-1000-00        |                               |         | 1   | LEAD SET, ELEC: 12 WIDE, 10.0 L                                        | 80009     | 012-1000-00     |
|                      | 015-0330-00        |                               |         | 1   | ADPTR, TEST CLIP: 16 DIP                                               | 80009     | 015-0330-00     |
|                      | 015-0339-00        |                               |         | 1   | ADPTR, TEST CLIP: 40 DIP                                               | 80009     | 015-0339-00     |
|                      | 015-0339-02        |                               |         | 1   | ADPTR, TEST CLIP: 40 DIP                                               | 80009     | 015-0339-02     |
|                      | 103-0209-00        |                               |         | 1   | ADAPTER, CONN: GPIB TO PROBE                                           | 80009     | 103-0209-00     |
|                      | 380-0560-05        |                               |         | 1   | HOUSING, TERM: MALE ADAPTER                                            | 80009     | 380-0560-05     |

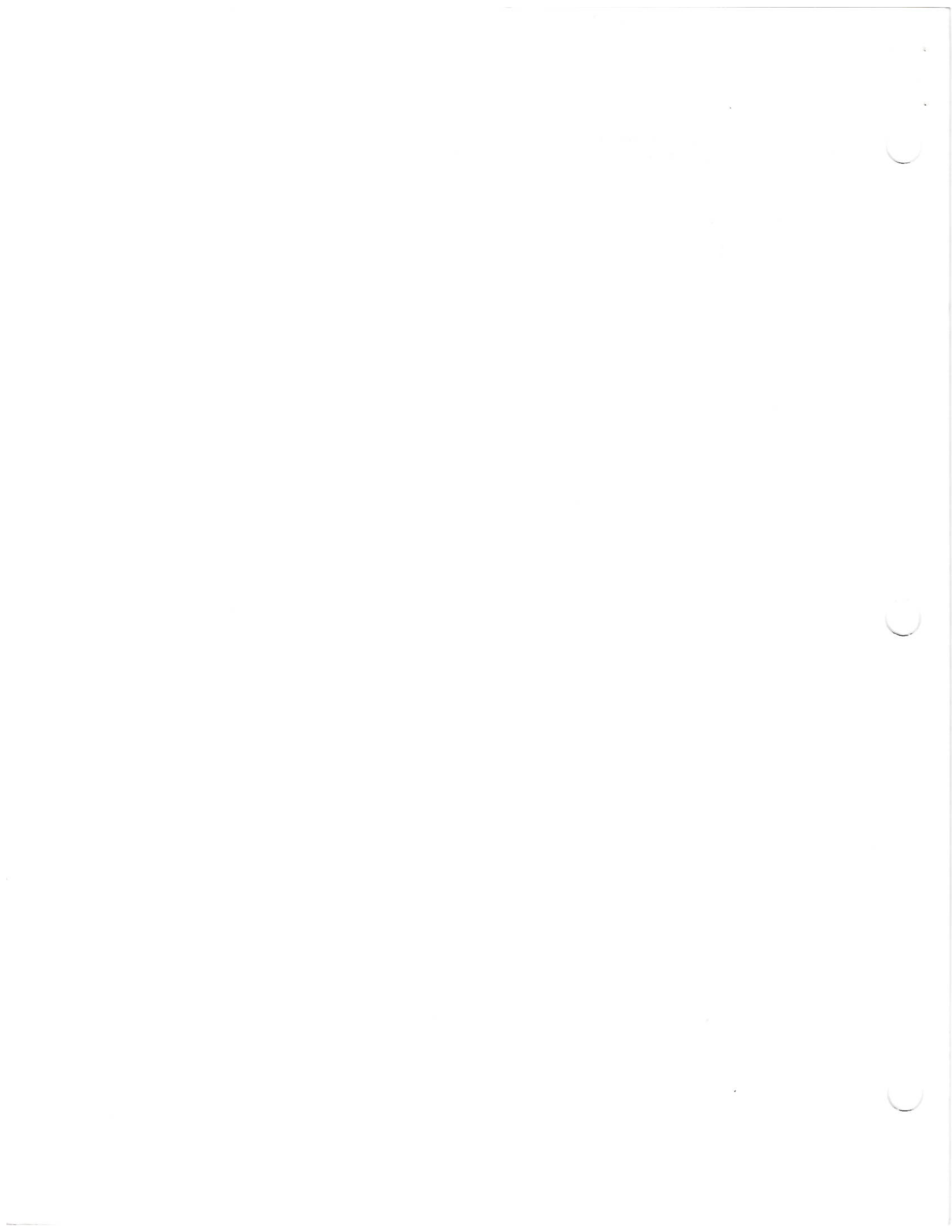



# DIAGRAMS AND CIRCUIT BOARD ILLUSTRATIONS

## Symbols

Graphic symbols and class designation letters are based on ANSI Standard Y32.2-1975.

Logic symbology is based on ANSI Y32.14-1973 in terms of positive logic. Logic symbols depict the logic function performed and may differ from the manufacturer's data.

The overline on a signal name indicates that the signal performs its intended function when it is in the low state.

Abbreviations are based on ANSI Y1.1-1972.

Other ANSI standards that are used in the preparation of diagrams by Tektronix, Inc. are:

- Y14.15, 1966 Drafting Practices.
- Y14.2, 1973 Line Conventions and Lettering.
- Y10.5, 1968 Letter Symbols for Quantities Used in Electrical Science and Electrical Engineering.

American National Standard Institute  
1430 Broadway  
New York, New York 10018

## Component Values

Electrical components shown on the diagrams are in the following units unless noted otherwise:

- Capacitors = Values one or greater are in picofarads (pF). Values less than one are in microfarads ( $\mu$ F).
- Resistors = Ohms ( $\Omega$ ).

———— The information and special symbols below may appear in this manual. ————

## Assembly Numbers and Grid Coordinates

Each assembly in the instrument is assigned an assembly number (e.g., A20). The assembly number appears on the circuit board outline on the diagram, in the title for the circuit board component location illustration, and in the lookup table for the schematic diagram and

corresponding component locator illustration. The Replaceable Electrical Parts list is arranged by assemblies in numerical sequence; the components are listed by component number \*(see following illustration for constructing a component number).

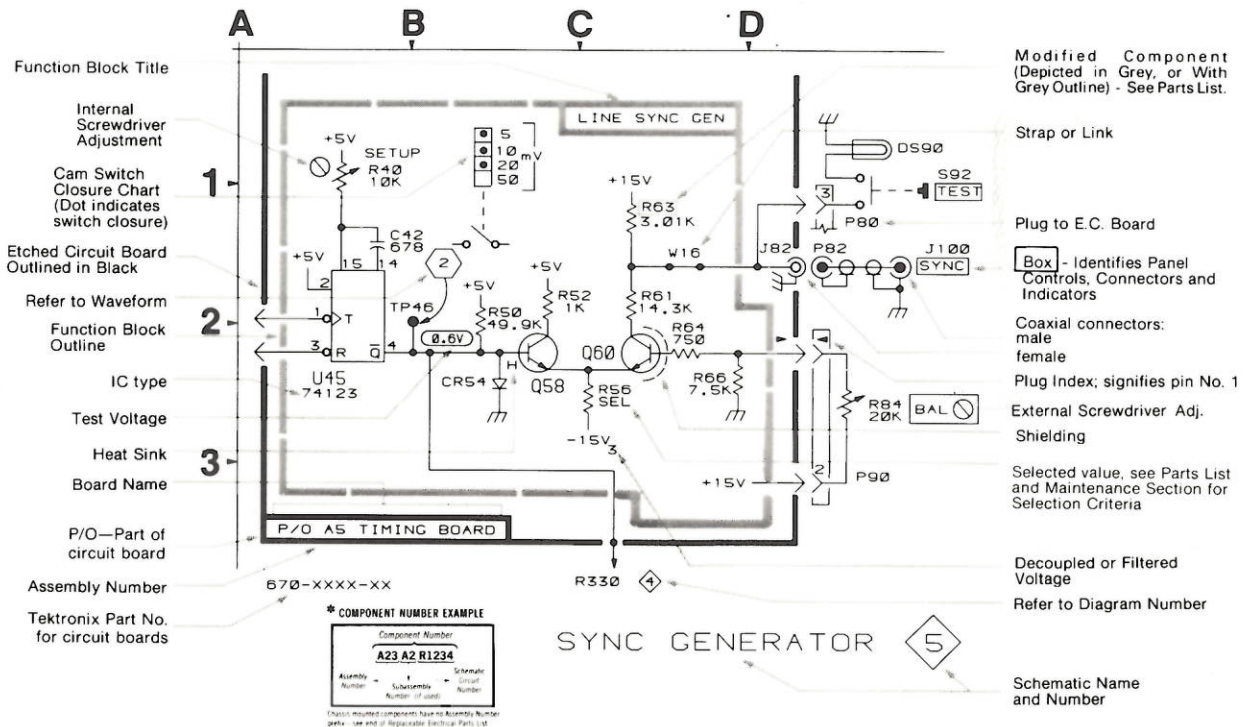

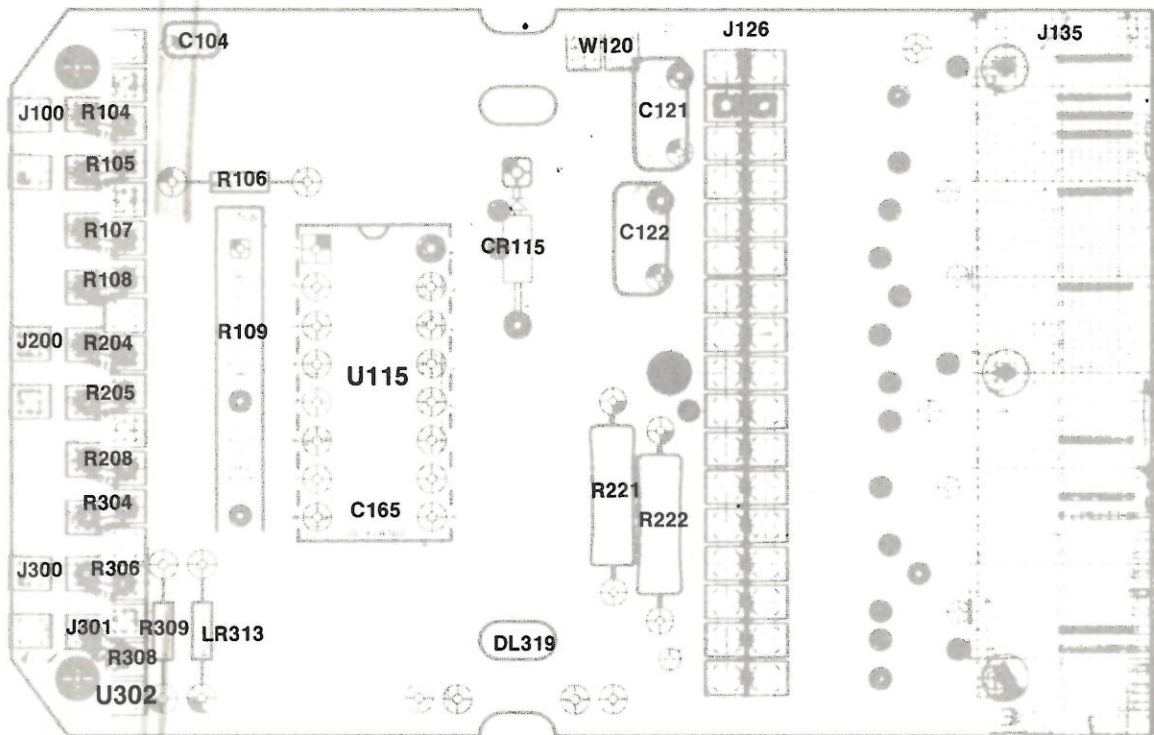

P6460 Board

4345-4

 Static Sensitive Devices  
See Maintenance Section

COMPONENT NUMBER EXAMPLE

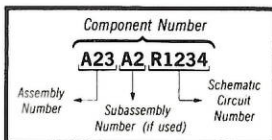

Chassis-mounted components have no Assembly Number prefix—see end of Replaceable Electrical Parts List.