

Operating

Instructions

TYPE
175

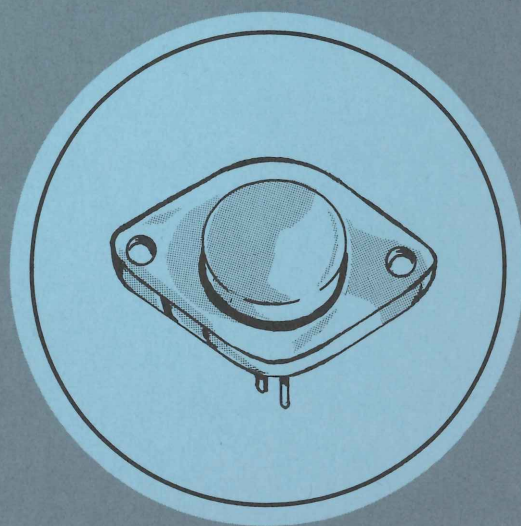

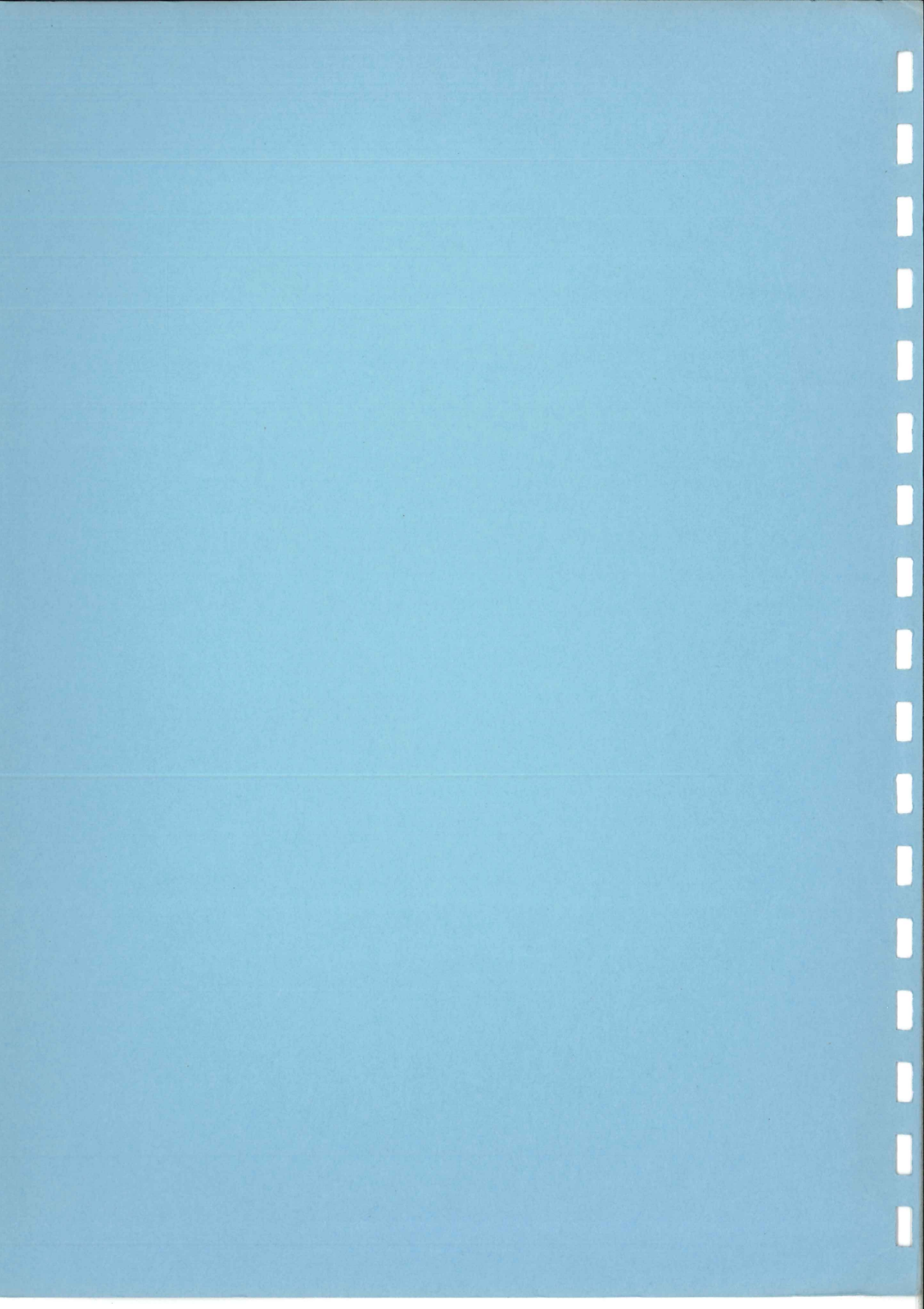

WARNING

On page 7 of this manual under "HORIZONTAL DISPLAY and STEP SELECTOR switches" there is an error in procedure. The step listed as step 2 should actually be the first step in the procedure.

Thus- Step 1 - Connect the resistor designated in the first column of Table 1 between the E and B binding posts of the TRANSISTOR A side of the Transistor Test Panel of the Type 175.

Step 2 - Set the STEP SELECTOR and HORIZONTAL DISPLAY switches in the positions shown in the second and third columns of the table.

Step 3 - Set the Transistor Selector Switch to TRANSISTOR A and the STEPS/FAMILY control (on the Type 575) fully clockwise. The Display on the Type 575 screen should contain the number of dots per division shown in the fourth column of the table.

The Transistor Selector switch should only be thrown while taking readings. If this procedure is not followed, arcing at switch and relay contacts will shorten life of the contacts, and may cause damage to test resistors because of the heavy current through them. Severe burns to the operator are possible from handling overheated resistors under these conditions.

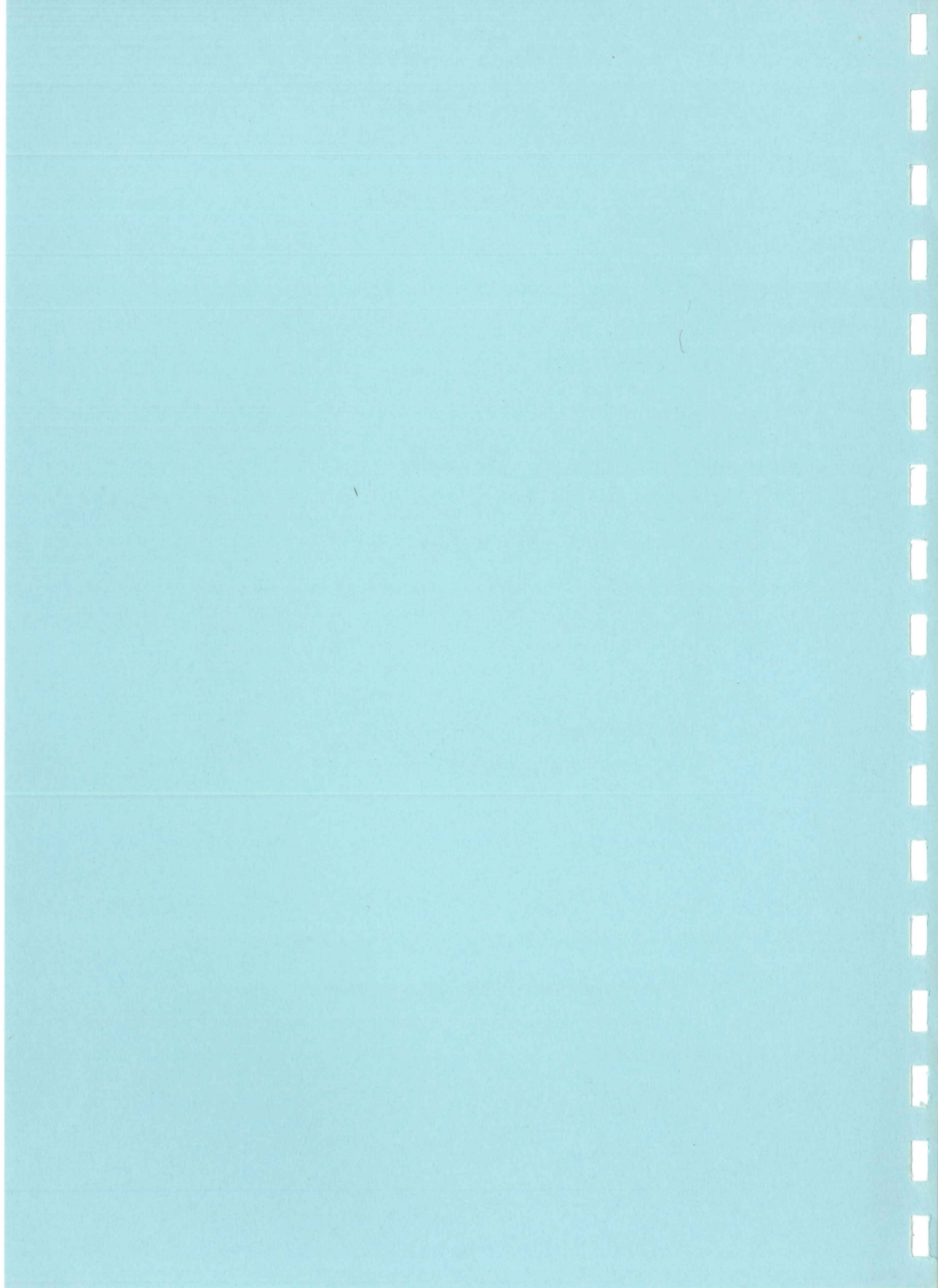

GENERAL DESCRIPTION

The Type 175 Transistor-Curve Tracer High-Current Adaptor, shown in Fig. 1, enables the Type 575 Transistor-Curve Tracer to plot and display the characteristic curves of high-power transistors. Basically, the Type 175 High-Current Adaptor contains a Collector Sweep circuit and a Step Amplifier which are used in place of those in the Type 575. These circuits are capable of handling peak collector currents of more than 200 amperes and base currents up

to 12 amperes. The Type 175 also contains the necessary voltage-dropping and current-sampling resistors for translating these high currents and voltages into deflection voltages suitable for display on the Type 575 crt.

The Step Generator and the Horizontal and Vertical Amplifiers in the Type 575 perform the same functions when the Type 175 is used with the Type 575 as when the Type 575 is used by itself.

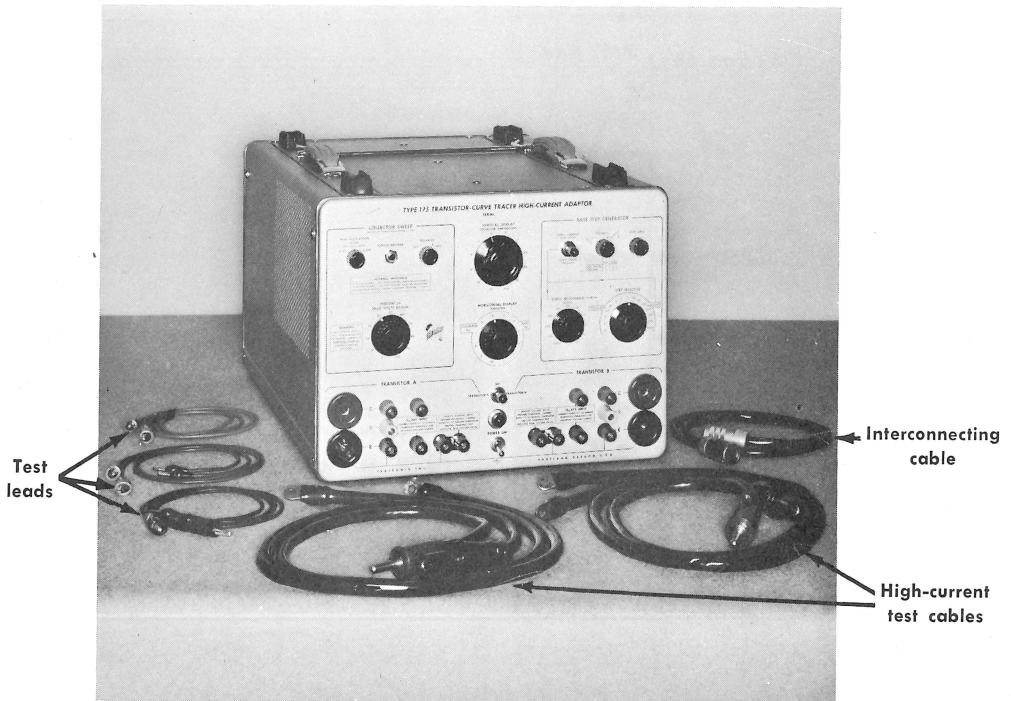

Fig. 1. Type 175 Transistor-Curve Tracer High-Current Adaptor.

INSTALLATION INSTRUCTIONS

If your Type 575 Transistor-Curve Tracer has not been modified for use with the Type 175 High-Current Adaptor, it will be necessary for you to do so before the two can be operated

together. The following instructions tell you how to make this modification and how to mount the Type 575 on top of the Type 175 to make a convenient operating unit.

Modification

Drill five holes in the upper left corner (facing the instrument from the rear) of the rear panel according to the dimensions shown in Fig 2. Mount the Type 175 interconnecting plug and harness in the holes and connect the wires as shown in Fig. 3 and Fig. 4.

Mounting

- Remove the two cabinet bolts from the bot-

tom front of the instrument and replace them with the two hinge bolts provided in the modification kit (see Fig. 5). If necessary, enlarge the holes in the Type 575 with a 3/16-inch drill. Set the Type 575 on top of the Type 175 so that the hinge bolts fall into the sockets in the front mounting feet on the Type 175. Insert the two 10-32 x 1 1/4" bolts through the holes in the mounting feet and the hinge bolts to hold the Type 575 securely in place. Note that the rear of the Type 575 can be raised for more convenient viewing. (see Fig. 6).

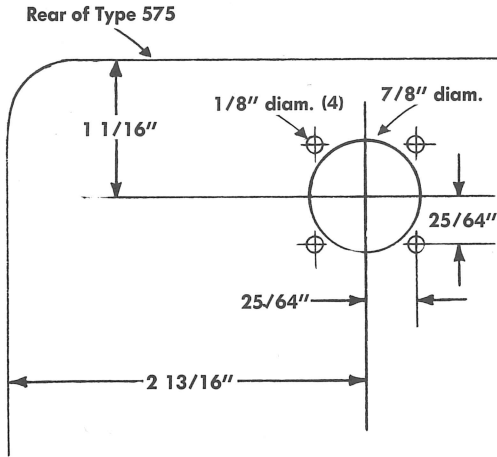

Fig. 2. Location and dimensions of holes for mounting interconnecting plug in Type 575.

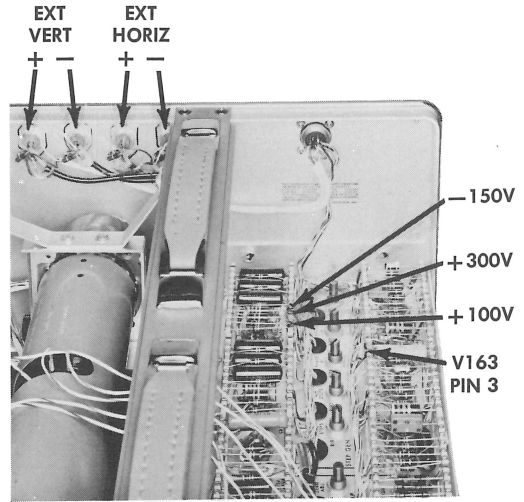

Fig. 3. Wiring connections to interconnecting plug in Type 575 (schematic).

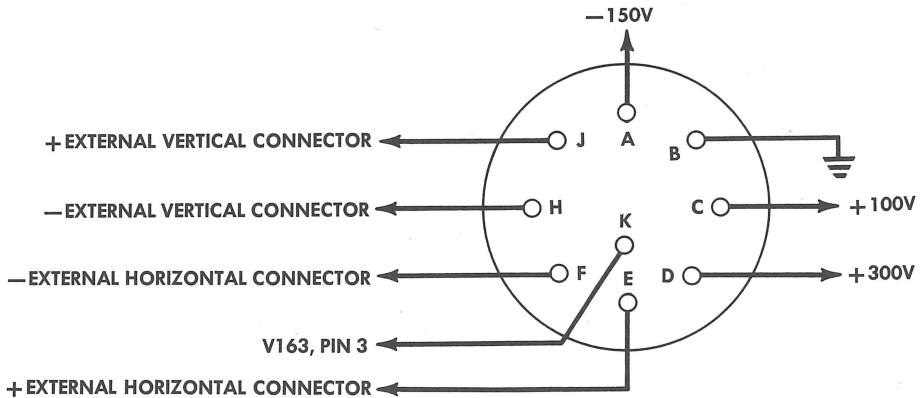

Fig. 4. Wiring connections to interconnecting plug in Type 575.

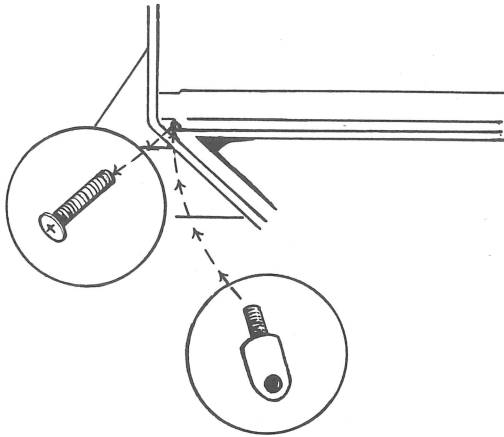

Fig. 5. Replacing cabinet bolts with hinge bolts in Type 575.

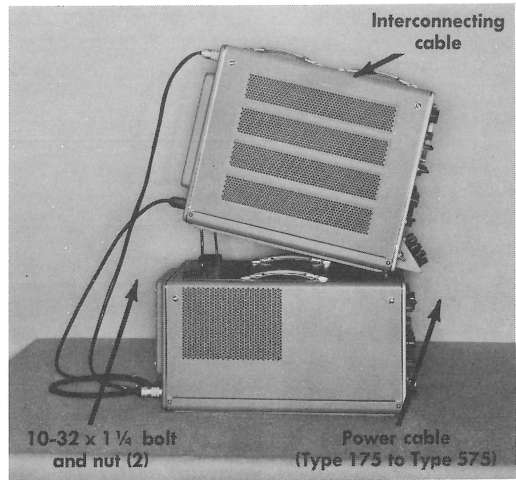

Fig. 6. Type 575 tilt-mounted on Type 175.

OPERATING INSTRUCTIONS

Operation of the Type 175 High-Current Adaptor with the Type 575 Transistor-Curve Tracer is essentially the same as operation of the Type 575 by itself. The only major difference is that the transistor connections are made at the Type 175 instead of the Type 575 and the front-panel controls of the Type 175 take the place of some of the front-panel controls of the Type 575.

The following instructions deal only with those parts of the operating procedure which are unique to combined operation; it is assumed that the operator is already familiar with the operation to the Type 575 by itself.

To operate the two instruments together, the interconnecting cable must be connected and the VERTICAL CURRENT OR VOLTAGE PER DIVISION and the HORIZONTAL VOLTS/DIV switches on the Type 575 must be set to EXT. For convenience, power to the Type 575 can be obtained from the POWER TO TYPE 575 connector on the rear of the Type 175. In this case, power to both instruments will be controlled by the Type 175 POWER ON switch. However, if it is intended that the Type 575 will be used frequently without the Type 175, it may be connected independently to its own

power source, if desired. It is not recommended to have power applied to the Type 175 when the Type 575 is turned off.

A discussion of the front-panel controls of the Type 175 and their relationship to the front-panel controls of the Type 575 follows. With the VERTICAL CURRENT OR VOLTAGE PER DIVISION and HORIZONTAL VOLTS/DIV switches on the Type 575 set to EXT., all other controls on the Type 575 whose functions are duplicated by controls on the Type 175 have no effect on the operation of the instruments.

VERTICAL DISPLAY Switch

The VERTICAL DISPLAY switch on the Type 175 takes the place of the VERTICAL CURRENT OR VOLTAGE PER DIVISION switch on the Type 575, except that there is no provision for displaying base volts vertically on the Type 175. The VERTICAL DISPLAY switch selects the amplitude of the signal fed to the Vertical Amplifier of the Type 575. This signal is proportional to the collector current flowing through the transistor under test.

The POSITION control, AMPLIFIER CALIBRATION switch, and DC. BAL. adjustment in the

VERTICAL block of the Type 575 perform exactly the same functions as they do without the Type 175.

COLLECTOR SWEEP Block

All of the controls in the COLLECTOR SWEEP block of the Type 175 perform the same functions, except for range of operation, as the corresponding controls on the Type 575. On the Type 175, there is no DISSIPATION LIMITING RESISTOR switch; the 300-ohm resistor inserted in series with the collector of the transistor in one of the PEAK VOLTS RANGE switch positions is the only dissipation limiting resistor available in the Type 175. If you wish to insert additional external dissipation limiting resistors, connect them in series with the collector of the transistor under test. With these additional resistors inserted in the circuit, it will be necessary to use test leads connected to the V_{CE} EXT. INPUT terminals, as described in the discussion of the Transistor Test Panel, for accurate presentation of collector-to-emitter voltages.

BASE STEP GENERATOR Block

All of the controls in the BASE STEP GENERATOR block of the Type 175 perform the same functions, except for range of operation, as the corresponding controls on the Type 575. The Display Selector switch (REPETITIVE—SINGLE FAMILY), the STEPS/FAMILY control, and the STEPS/SEC switch on the Type 575 perform the same functions as they do without the Type 175.

Transistor Test Panel

The Transistor Test Panel of the Type 175

is basically the same as that of the Type 575. Special connectors and cables are provided for high-current applications and for elimination of measurement errors due to voltage drops in high-current-carrying leads.

As with the Type 575 panel, the collector, base, and emitter connections are made to the binding posts C, B and E, respectively. If a peak collector current of more than about 25 amperes is expected, connect the collector and emitter to the large C and E terminals on the Type 175 through the high-current test cables provided (see Fig. 1).

With long leads to the collector and emitter of high-current transistors, or with dissipation limiting resistors inserted in series with a transistor, the voltage drop in the leads themselves may be enough to introduce a significant error into the voltage across the transistor as seen by the oscilloscope. This problem can be eliminated by connecting test leads from the collector and emitter of the transistor under test to the red and black V_{CE} EXT. INPUT terminals, respectively. These test leads are essentially non-current-carrying and provide a more accurate indication to the Horizontal Amplifier of the voltage at the transistor itself.

Also, the voltage drop in a high-current-carrying emitter lead can cause some loss in the base-drive voltage at the transistor, thereby making each base step less than that indicated by the setting of the STEP SELECTOR switch. (This applies only when the STEP SELECTOR is in one of the VOLTS/STEP positions.) For this reason, when high-current transistors are being tested with voltage steps at the base, you should remove the strap between the two REMOTE VOLTAGE-DRIVE GROUND REFERENCE binding posts and connect a lead from the ungrounded post to the emitter lead of the transistor itself.

CIRCUIT DESCRIPTION

Block Diagram

Fig. 7 shows a simplified circuit diagram of the Type 175 connected to the Type 575 for plotting collector current versus collector-to-emitter voltage of an NPN transistor. Most of the switching has been omitted from this diagram.

Overall operation of the unit is as follows: The step output from the Type 575 Step Generator is applied through pin K of the interconnecting plug to the Step Amplifier in the Type 175. The Type 175 Step Amplifier applies the steps to the base of the transistor under test while the Type 175 Collector Sweep circuit sweeps the collector voltage from zero to a

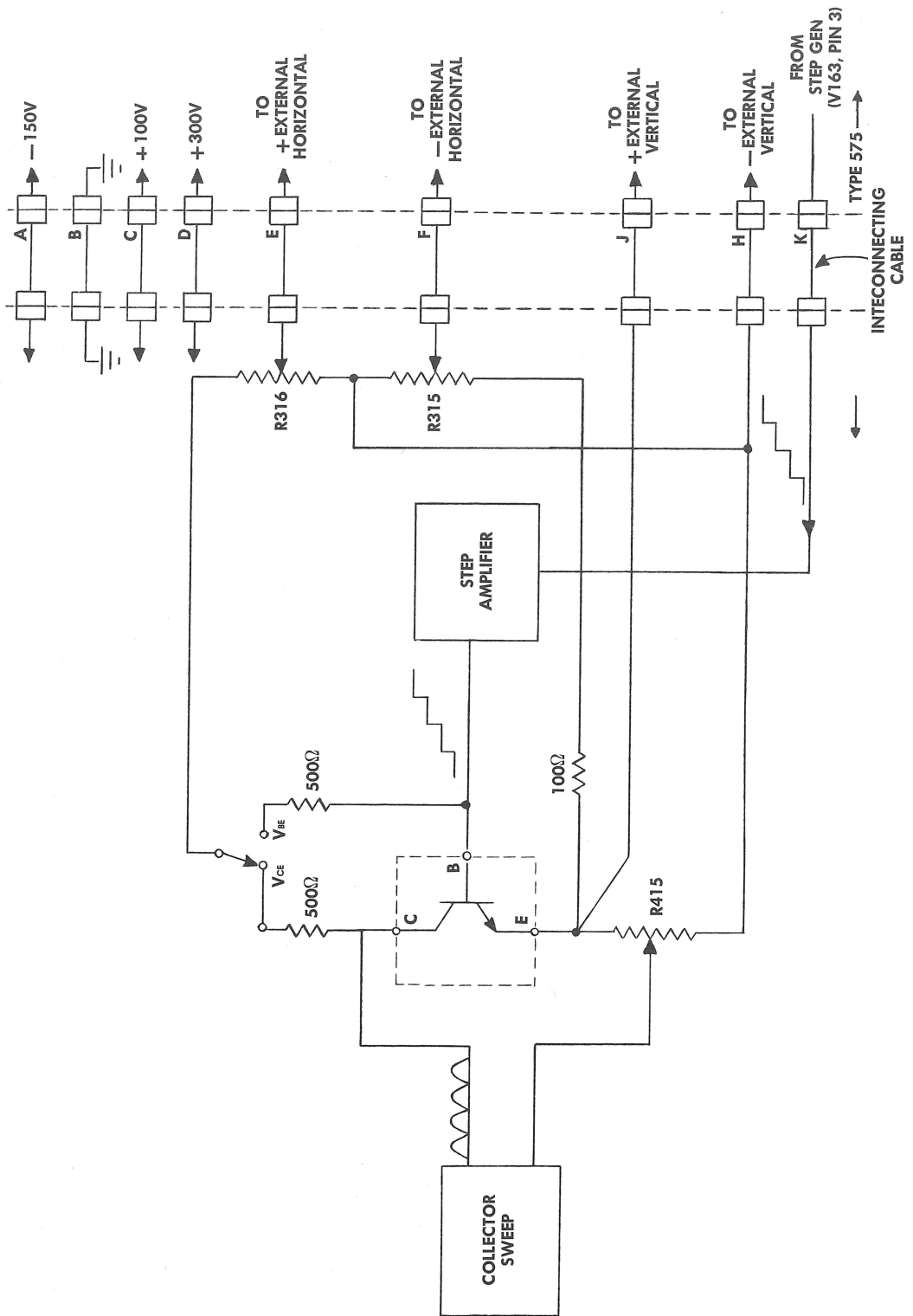

Fig. 7. Simplified circuit diagram of Type 175 Transistor-Curve Tracer High-Current Adapter.

peak voltage determined by the setting of the Type 175 controls. The time relationship between the collector sweeps and the base steps is the same as in the Type 575 alone. The number of steps per family and the number of steps per second are determined by the setting of the Type 575 controls. Polarity of the steps is determined by the Type 175.

The voltage drop across R415 is proportional to the current through it. This voltage is applied through pins H and J of the interconnecting plug to the Vertical Amplifier of the Type 575. The voltage difference between the switch arms of R315 and R316 is proportional to the collector-to-emitter voltage across the transistor. This voltage is applied through pins E and F of the interconnecting plug to the Horizontal Amplifier of the Type 575. (Both the VERTICAL CURRENT OR VOLTAGE PER DIVISION and the HORIZONTAL VOLTS/DIV switches of the Type 575 are in the EXT. position for operation with the Type 175 Adaptor.

Collector Sweep

The Collector Sweep circuit in the Type 175 is essentially the same as that in the Type 575 except for current and voltage capabilities. Full-wave rectification of the 60-cycle line voltage produces 120 sweeps per second from 0 to 20 or 0 to 100 volts peak. These sweeps may be applied as either positive-going or negative-going voltages to the collector of either of two transistors under test by means of switch-actuated relays.

The Collector Sweep circuit is capable of supplying peak currents of over 200 amperes through the transistor under test at the 0-to-20 volt range of the PEAK VOLTS RANGE switch and over 40 amperes in the 0-to-100 volt range. The circuit breaker in the primary circuit of T702 is nominally rated at 8 amperes rms, but is capable of carrying considerably higher currents for short periods of time. The primary voltage of T702 is variable between zero and line voltage by means of the PERCENT OF PEAK VOLTS RANGE control. This provides a maximum average input power rating of about 1 kilowatt. Again, peak power can surpass this average by several times for short periods.

In one of the 0-100 positions of the PEAK VOLTS RANGE switch, a 300-ohm resistor (R720)

is inserted in series with the output of T702 as a dissipation limiting resistor. Additional limiting resistors may be added externally, if desired (see Operating Instructions, "Collector Sweep Block".)

The internal resistance of the Collector Sweep circuit, exclusive of the current-sampling resistor (R415) and R720, is 0.03 ohm when the PEAK VOLTS RANGE switch is in the 0-20 position, and 0.5 ohm when the PEAK VOLTS RANGE switch is in the 0-100 position. Because of this low internal impedance, it is possible, in the more sensitive positions of the VERTICAL DISPLAY switch and with the C and E terminals shorted or nearly shorted, to dissipate enough power within the Type 175 to cause damage to the components. For this reason, the VERTICAL DISPLAY switch should always be in such a position that the maximum collector-current signal does not exceed a maximum amplitude of about five screen diameters.

A counterpart for V733 in the Type 575 is not required in the Type 175 because currents due to stray capacitance in the Type 175 are negligible compared to the high currents being measured.

Step Amplifier

The Step Amplifier in the Type 175 is virtually the same as that of the Type 575. The only significant differences are the use of 20-volt floating power supplies in place of 15-volt power supplies and the use of four parallel-connected transistors in the output stage. (The output of the 20-volt supplies is actually about 25 volts at nominal line voltage.) The Type 175 is capable of supplying a maximum base current of 12 amperes whereas the Type 575 supplies a maximum base current of only about 2.4 amperes.

The 20-volt supplies for the Step Amplifier are shown on the Power Supply schematic diagram. Diode-connected transistors are used in the negative supply to handle the additional current which must flow through that supply.

R244R and R244S reduce the transients which appear at the base of the transistor under test whenever the STEP SELECTOR switch is moved from one position to the next. They are shorted out except when the switch is between positions.

MAINTENANCE

General maintenance information, such as filter cleaning, parts replacement and ordering, and general troubleshooting instructions is the same for the Type 175 as for the Type 575. Therefore, the following information is concerned only with specific troubleshooting procedures for the Type 175 Step Amplifier and Collector Sweep circuit and the associated switches.

Troubleshooting the Step Amplifier

Troubleshooting the Step Amplifier of the Type 175 can be accomplished by the same procedures as for the Type 575 (note, however, that in some cases corresponding parts are numbered differently). As with the Type 575, the voltage drop across the current-sampling resistor (R244 in the Type 175, R246 in the Type 575) should increase from zero by 0.5 volt step regardless of the position of the STEP SELECTOR switch. The maximum current which must be supplied by the Step Amplifier power supplies in the Type 175 is 12 amperes as compared to 2.4 amperes in the Type 575. Note also that the Type 175 Step Amplifier has a VOLTS/STEP ADJ. adjustment at its input, the setting of which can affect the amplitude of the signal throughout the circuit.

Troubleshooting the Collector Sweep Circuit

The cause of insufficient or no output voltage from the Collector Sweep circuit can be isolated by continuity checks through the circuit. Verification of sufficient output can be made by measurements described later in the procedure for checking the resistors of the VERTICAL DISPLAY switch.

Checking Switch Resistance

The following procedures tell you how to check the resistors in the HORIZONTAL DISPLAY, STEP SELECTOR, VERTICAL DISPLAY, and SERIES RESISTANCE switches of the Type 175 for proper values. Since the Type 575 and the Type 175 are essentially self-checking, this can be done by measurements observed on the

screen of the Type 575. In each measurement, the faulty resistor can be determined by comparing the position of the switch in which a faulty indication is obtained with the appropriate schematic diagram. To perform the measurements, you will need four precision (1%) resistors of the following values and ratings: 100 ohms, 4 watts; 2 ohms, 4 watts; 0.05 ohms, 1000 watts; and 10 ohms, 1000 watts. These resistors will be referred to in the procedure by their resistance values only.

Throughout the procedures, the Type 175 and Type 575 should be connected together for combined operation, as described under Operating Instructions, and turned on, unless otherwise noted. For a complete checkout of all switches, the procedures should be performed in the order presented. If you merely wish to check the operation of one of the switches, you may check it separately as long as you realize that, in these procedures, an off-value resistor in the HORIZONTAL DISPLAY switch can make any of the other switches (except the SERIES RESISTANCE switch) appear faulty.

HORIZONTAL DISPLAY and STEP SELECTOR Switches. To check the resistors associated with the HORIZONTAL DISPLAY and STEP SELECTOR switches, proceed as follows:

1. Set the Transistor Selector switch to TRANSISTOR A and the STEPS/FAMILY control (on the Type 575) fully clockwise.
2. Connect the resistor designated in the first column of Table I between the E and B binding posts of the TRANSISTOR A side of the Transistor Test Panel of the Type 175.
3. Set the STEP SELECTOR and HORIZONTAL DISPLAY switches to the positions shown in the second and third columns of the table. The display on the Type 575 screen should contain the number of dots per division shown in the fourth column of the table.
4. Continue in like manner down the table, inserting the proper resistor and setting the controls as designated, and check for the proper number of dots per division in the display for each measurement. (Remove the resistor for the last five measurements on the table.)

TABLE I

Resistor (between E and B posts)	STEP SELECTOR switch	HORIZONTAL DISPLAY switch (BASE V_{BE})	Dots per division
100 Ω	1 MA/STEP	.1	1
100 Ω	1 MA/STEP	.2	2
100 Ω	2 MA/STEP	.2	1
100 Ω	2 MA/STEP	.5	5 dots per 2 divisions
100 Ω	5 MA/STEP	.5	1
100 Ω	5 MA/STEP	1	2
100 Ω	10 MA/STEP	1	1
100 Ω	10 MA/STEP	2	2
100 Ω	20 MA/STEP	2	1
2 Ω	50 MA/STEP	.1	1
2 Ω	100 MA/STEP	.2	1
2 Ω	200 MA/STEP	.5	4 dots per 5 divisions
2 Ω	500 MA/STEP	1	1
2 Ω	1000 MA/STEP	1	1 dot per 2 divisions
open	.02 VOLTS/STEP	.1	5
open	.05 VOLTS/STEP	.1	2
open	.1 VOLTS/STEP	.1	1
open	.2 VOLTS/STEP	.1	1
open	.5 VOLTS/STEP	.1	1

If an incorrect display first occurs in the second, fourth, sixth, or eighth measurement of the table, the trouble is in the corresponding position of the HORIZONTAL DISPLAY switch. An incorrect display in any of the other measurements indicates that the trouble is in the corresponding position of the STEP SELECTOR switch. A small consistent error at all positions of both switches indicates a need for adjustment of the internal VOLTS/STEP ADJ. adjustment (see Calibration). If the dots are consistently farther apart in the VOLTS/STEP positions of the STEP SELECTOR switch than in the MA/STEP positions, this indicates that R246 has increased in value or the wiring resistance of the circuit has increased. Conversely, if the dots are consistently closer together in the VOLTS/STEP positions of the STEP SELECTOR switch than in the MA/STEP positions, this indicates that R246 has decreased in value or has become shorted.

HORIZONTAL DISPLAY Switch (COLLECTOR V_{CE} Positions) After you have verified the accuracy of all of the BASE V_{BE} positions of the HORIZONTAL DISPLAY switch, proceed as fol-

lows to check the resistors associated with the COLLECTOR V_{CE} positions of the switch:

1. Set the Transistor Selector switch to TRANSISTOR A, the PEAK VOLTS RANGE switch to 0-20, and the PERCENT OF PEAK VOLTS RANGE control to 0.
2. Set the HORIZONTAL DISPLAY switch to 2 COLLECTOR V_{CE} .
3. Rotate the PERCENT OF PEAK VOLTS RANGE control clockwise until you obtain exactly 10 divisions of horizontal deflection on the screen.
4. Set the HORIZONTAL DISPLAY switch to 5 COLLECTOR V_{CE} . There should be four divisions ($\pm 2\%$) of horizontal deflection on the screen.
5. Return the PERCENT OF PEAK VOLTS RANGE control to 0.
6. Set the PEAK VOLTS RANGE switch to 0-100 and the PERCENT OF PEAK VOLTS RANGE control for exactly 10 divisions of horizontal deflection.

7. Set the HORIZONTAL DISPLAY switch to 10 COLLECTOR V_{CE} . There should be five divisions ($\pm 2\%$) of horizontal deflection on the screen.

(The remaining COLLECTOR V_{CE} positions of the HORIZONTAL DISPLAY switch use the same resistors as the BASE V_{BE} positions which were checked previously.)

VERTICAL DISPLAY Switch. In checking the resistances in the VERTICAL DISPLAY switch, the output of the Collector Sweep circuit is applied across an externally connected resistor at each setting of the VERTICAL DISPLAY switch. The voltage across the resistor is displayed as horizontal deflection and the current through the resistor is displayed as vertical deflection. The slope of the line displayed, as the Collector Sweep output sweeps between zero and a selected maximum voltage, should indicate the value of the external resistance. Any deviation from the proper slope indicates an off-value current sampling resistor (assuming that the resistances in the HORIZONTAL DISPLAY switch as measured previously are all correct).

To check the resistances in the VERTICAL DISPLAY switch, proceed as follows:

1. Set the PERCENT OF PEAK VOLTS RANGE control to 0.

2. Set the COLLECTOR SWEEP POLARITY switch on the Type 175 to +.

3. Connect the resistor designated in Column A of Table II between the large C and E terminals on the TRANSISTOR A side of the transistor Test Panel of the Type 175 using the high-current test cables.

4. Connect test leads from the ends of the resistor to the V_{CE} EXT. INPUT binding posts on the same side of the Transistor Test Panel.

5. Set the Transistor Selector switch to TRANSISTOR A.

6. Set the PEAK VOLTS RANGE, VERTICAL DISPLAY, and HORIZONTAL DISPLAY switches on the Type 175 to the positions designated in columns B, C, and D of Table II.

7. Adjust the POSITION controls on the Type 575 to position the spot to the lower left corner of the graticule.

8. Rotate the PERCENT OF PEAK VOLTS RANGE control clockwise until you obtain the horizontal deflection specified in column E of the table. The slope of the line (Δ vertical deflection divided by Δ horizontal deflection) should be within 2% of that specified in column F.

NOTE

In the first measurement, you may not be able to obtain the full 10 divisions of horizontal deflection before the

TABLE II

A Resistor	B PEAK VOLTS RANGE	C VERTICAL DISPLAY	D HORIZONTAL DISPLAY	E Horizontal Deflection	F Slope
0.05 Ω	0-20	20	1	10 div.	1.00
0.05 Ω	0-20	10	.5	10 div.	1.00
0.05 Ω	0-20	5	.2	10 div.	0.80
0.05 Ω	0-20	2	.1	10 div.	1.00
10 Ω	0-100	1	10	9.9 div.	1.00
10 Ω	0-100	.5	5	10 div.	1.00
10 Ω	0-20	.2	2	9.1 div.	1.00
10 Ω	0-20	.1	1	10 div.	1.00
10 Ω	0-20	.05	.5	10 div.	1.00
10 Ω	0-20	.02	.2	10 div.	1.00
10 Ω	0-20	.01	.1	10 div.	1.00
10 Ω	0-20	.005	.1	5 div.	2.00

circuit breaker actuates. However, if the slope of the displayed line is correct, the measurement may be considered to be within tolerance. If the circuit breaker does actuate, return the PERCENT OF PEAK VOLTS RANGE control to 0 and wait one minute for the heating element in the breaker to cool before resetting it.

9. Return the PERCENT OF PEAK VOLTS RANGE control to 0 after each measurement.

10. Continue in like manner down the table, inserting the proper resistor and setting the controls as designated, and check for adequate deflection and proper slope on the Type 575 screen. If any of the slopes are not correct, or if adequate horizontal deflection cannot be obtained, make a note of it (whether the slope is greater or less than specified) and go on to the next measurement.

If the slope is correct for the first few measurements in Table II, but is incorrect for the remaining measurements, this indicates that one of the current-sampling resistors has changed in value. It will generally be the resistor associated with the VERTICAL DISPLAY switch position at which the incorrect slope first occurred as you progressed down the table. If

the slope is greater than specified, the resistor has increased in value; if the slope is less than specified, the resistor has decreased in value.

Insufficient horizontal deflection in the fifth and/or seventh measurements of the table (1 and .2 positions of the VERTICAL DISPLAY switch, respectively) indicates that the internal resistance of the Collector Sweep circuit itself has increased beyond its proper value. In this case, check T702 and the associated rectifier diodes as described in the paragraph on Troubleshooting the Collector Sweep Circuit.

SERIES RESISTANCE switch. To check the resistors in the SERIES RESISTANCE switch, proceed as follows:

1. Turn the Type 175 off.
2. Set the Transistor Selector switch to TRANSISTOR A.
3. Set the STEP SELECTOR switch to .02 VOLTS/STEP.
4. Measure the resistance between the E and B binding posts of the TRANSISTOR A side of the Transistor Test Panel at each setting of the SERIES RESISTANCE switch. In each case, the resistance should be within 5% of that indicated by the setting of the switch.

CALIBRATION

There are only three internal adjustments in the Type 175 High-Current Adaptor: the ZERO ADJ., the \pm ADJ., and the VOLTS/STEP ADJ. (See Fig 8). They all perform the same functions as the corresponding adjustments in the Type 575. They should be adjusted only after the Type 575 has been properly calibrated.

To properly set the internal adjustments of the Type 175, proceed as follows:

1. Set the front-panel controls as follows:

HORIZONTAL DISPLAY (Type 175)	.1V _{BE}
Display Switch (Type 575)	REPETITIVE
POLARITY (Type 175 Base Step Generator)	—
STEP SELECTOR (Type 175)	.1 VOLTS PER STEP
STEP ZERO (Type 175)	midrange
Transistor Selector switch	TRANSISTOR B

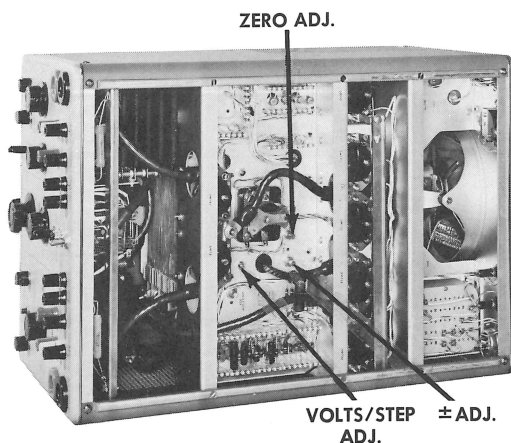

Fig. 8. Bottom of Type 175, showing internal adjustments.

2. Position the display so the last dot to the right is in the center of the graticule.

3. Set the ZERO ADJ. adjustment in the Type 175 so that this dot does not move as the Type 175 Base Step Generator POLARITY switch is switched from one position to the other. (The other dots will shift from one side to the other as the POLARITY is switched.) Leave the POLARITY switch in the — position when you are finished with this step.

4. Hold the HORIZONTAL AMPLIFIER CALIBRATION switch in the ZERO CHECK position, and position the dot directly behind the center vertical graticule line.

5. Release the switch and set the \pm ADJ. ad-

justment so that the last dot to the right is directly behind the center vertical graticule line.

6. Set the STEP SELECTOR switch to .5 VOLTS PER STEP and repeat steps 2 through 5 until both the ZERO ADJ. and the \pm ADJ. are properly set.

7. Set the STEP SELECTOR switch to .1 VOLTS PER STEP and turn the STEPS/FAMILY control on the Type 575 fully clockwise.

8. Position the display of dots so that it extends across the graticule.

9. Set the VOLTS/STEP adjustment on the Type 175 for one dot per major graticule division.



WARRANTY

All Tektronix instruments are warranted against defective materials and workmanship for one year. Tektronix transformers, manufactured in our own plant, are warranted for the life of the instrument.

Any questions with respect to the warranty mentioned above should be taken up with your Tektronix Field Engineer.

Tektronix repair and replacement-part service is geared directly to the field, therefore all requests for repairs and replacement parts should be directed to the Tektronix Field Office or Representative in your area. This procedure will assure you the fastest possible service. Please include the instrument Type and Serial number with all requests for parts or service.

Specifications and price change privileges reserved.

Copyright © 1960 by Tektronix, Inc., Beaverton, Oregon. Printed in the United States of America. All rights reserved. Contents of this publication may not be reproduced in any form without permission of the copyright owner.

PARTS LIST

Bulbs

			Tektronix Part Number
B231	Neon, NE-2		150-002
B266	Neon, NE-2		150-002
B601	Incandescent #47		150-001

Capacitors

Values fixed unless marked Variable.

Tolerance $\pm 20\%$ unless otherwise indicated.

C232	.001 μf	PTM	600 v	285-501
C238	.015 μf	PTM	400 v	285-512
C267	.001 μf	PTM	600 v	285-501
C620	2000 μf	EMC	30 v	290-087
C621	20,000 μf	EMC	30 v	290-131
C650	6.25 μf	EMT	300 v	290-025
C653	6.25 μf	EMT	300 v	290-025

Fuses

F601	3 Amp	3 AG	Slo-Blo	159-005
F602	3 Amp	3 AG	Slo-Blo	159-005

Resistors

Resistors are fixed, composition, $\pm 10\%$, unless otherwise indicated.

R201	15 k		Var.		Volts/Step Adj.	311-112
R202	82 k	$\frac{1}{2}$ w		Prec.	1%	309-043
R203	3 k	$\frac{1}{2}$ w		Prec.	1%	309-182
R204	68 Ω	$\frac{1}{2}$ w				302-680
R206	600 k	$\frac{1}{2}$ w		Prec.	1%	309-004
R207	100 k		Var.		STEP ZERO	311-026
R210	470 k	$\frac{1}{2}$ w				302-474
R215	47 k	$\frac{1}{2}$ w				302-473
R216	4.7 k	$\frac{1}{2}$ w				302-472
R217	20 k		Var.		Zero Adj.	311-018
R218	47 k	$\frac{1}{2}$ w				302-473
R222	150 k	$\frac{1}{2}$ w				302-154
R224	1 k	$\frac{1}{2}$ w				302-102
R231	1.5 meg	$\frac{1}{2}$ w				302-155
R232	100 k	$\frac{1}{2}$ w				302-104

Resistors (continued)

						Tektronix Part Number	
R233	1 k	1/2 w				302-102	
R235	22 k	2 w				306-223	
R238	1.5 k	1/2 w				302-152	
R241	500 Ω	5 w				308-071	
R242A-D	0.25 Ω	1 w	WW	1%	(4)	*308-090	
R243A,B	125 Ω	25 w	WW	5%	(2)	308-035	
R244A	0.5 Ω	50 w	Base Step			*308-182	
R244B	1.25 Ω	20 w					
R244C	2.5 Ω	10 w					
R244D	5 Ω	5 w		Prec.	1%		310-569
R244E	12.5 Ω	3 w	Prec.	1%		310-576	
R244F	500 Ω	1/2 w	Prec.	1%		309-179	
R244G	250 Ω	1/2 w	Prec.	1%		309-178	
R244H	100 Ω	1/2 w	Prec.	1%		309-112	
R244J	50 Ω	1/2 w	Prec.	1%		309-128	
R244K	25 Ω	1/2 w	Prec.	1%		309-177	
R244L	10 Ω	3 w	Prec.	1%		310-570	
R244M	5 Ω	5 w	Prec.	1%		310-569	
R244N	2.5 Ω	10 w	Furnished with R244A,B,C			*308-182	
R244P	1 Ω	25 w					
R244Q	0.5 Ω	50 w					
R244R	1 k	1/2 w				302-102	
R244S	1 k	1/2 w				302-102	
R245A	1 k	1/2 w	Prec.	1%		309-115	
R245B	500 Ω	1/2 w	Prec.	1%		309-179	
R245C	200 Ω	1/2 w	Prec.	1%		309-073	
R245D	100 Ω	1/2 w	Prec.	1%		309-112	
R245E	50 Ω	1/2 w	Prec.	1%		309-128	
R245F	19.5 Ω	3 w	Prec.	1%		310-574	
R245G	9.5 Ω	3 w	Prec.	1%		310-573	
R245H	4.5 Ω	5 w	Prec.	1%		310-575	
R245J	1.5 Ω	5 w	Prec.	1%		310-572	
R245K	.5 Ω	5 w	Prec.	1%		310-571	
R246	0.5 Ω	Furnished with R244A,B,C				*308-182	
R251	1 k	1/2 w				302-102	
R254	47 k	1/2 w				302-473	
R255	4.7 k	1/2 w	Var.	±Adj.		302-472	
R256	20 k						311-018
R257	47 k	1/2 w					302-473
R261	150 k	1/2 w					302-154
R264	470 k	1/2 w					302-474

Resistors (continued)

Tektronix
Part Number

R266	1.5 meg	1/2 w			302-155
R267	100 k	1/2 w			302-104
R268	1 k	1/2 w			302-102
R269	47 k	1 w			304-473
R273	430 Ω	1/2 w		5%	301-431
R274	100 Ω	1/2 w			302-101
R275	10 k	1/2 w			302-103
R315A	1.11 k	1/2 w	Prec.	1%	309-284
R315B	1.11 k	1/2 w	Prec.	1%	309-284
R315C	3.37 k	1/2 w	Prec.	1%	309-320
R315D	5.64 k	1/2 w	Prec.	1%	309-321
R315E	11.48 k	1/2 w	Prec.	1%	309-192
R315F	34.5 k	1/2 w	Prec.	1%	309-038
R315G	54 k	1/2 w	Prec.	1%	309-322
R316A	1.11 k	1/2 w	Prec.	1%	309-284
R316B	1.11 k	1/2 w	Prec.	1%	309-284
R316C	3.37 k	1/2 w	Prec.	1%	309-320
R316D	5.64 k	1/2 w	Prec.	1%	309-321
R316E	11.48 k	1/2 w	Prec.	1%	309-192
R316F	34.5 k	1/2 w	Prec.	1%	309-038
R316G	54 k	1/2 w	Prec.	1%	309-322
R415A	10 Ω	}	Current Measuring		*308-181
R415B	5 Ω				
R415C	3 Ω				
R415D	1 Ω				
R415E	0.5 Ω				
R415F	0.3 Ω	}	Current Measuring Shunt		*308-180
R415G	0.1 Ω				
R415H	.05 Ω				
R415J	.03 Ω				
R415K	.01 Ω				
R415L	.005 Ω				
R415M	.005 Ω				
R501	500 Ω	10 w	WW		*308-183
R502	500 Ω	10 w	WW		*308-183
R506	500 Ω	10 w	WW		*308-183
R507	500 Ω	10 w	WW		*308-183
R510	120 Ω	5 w	WW	5%	308-163
R650	47 Ω	1/2 w			302-470
R653	47 Ω	1/2 w			302-470
R720	300 Ω	50 w	Furnished with R415A-D		*308-181
R740	100 Ω	1/2 w			302-101

Diodes

		Tektronix Part Number
D610	1N1563A	152-035
D611	1N1563A	152-035
D616	1N1563A	152-035
D617	1N1563A	152-035
D620	1N1563A	152-035
D621	1N1563A	152-035
D710	45L10	152-028
D711	45L10	152-028
D716	TR351	152-029
D717	TR351	152-029

Transistors

Q233	2N250	151-018
Q243A	2N277	151-002
Q243B	2N277	151-002
Q243C	2N277	151-002
Q243D	2N277	151-002
Q620	2N554	151-034
Q621	2N554	151-034

Switches

		Wired	Unwired
SW241	BASE POLARITY		*260-365
SW244	STEP SELECTOR	*262-382	*260-363
SW245	SERIES RESISTANCE	*262-383	*260-355
SW247	ZERO CURRENT; ZERO VOLTS		*260-317
SW315	HORIZONTAL DISPLAY; VOLTS/DIV.	*262-384	*260-364
SW415	VERT. DISP; COLLECTOR CURRENT/DIV.		*260-338
SW510	TRANSISTOR SELECTOR		*260-339
SW601	POWER ON		260-199
SW603	115 V Relay, SPST 20 amp		148-015
SW630	COLLECTOR SWEEP POLARITY		*260-366
SW701	CIRCUIT BREAKER		*260-337
SW720	PEAK VOLTS RANGE		*260-367
SW721	12 V Relay, SPST 100 amp		148-014
SW731	12 V Relay, SPST 100 amp		148-014
SW732	12 V Relay, SPST 100 amp		148-014
SW735	12 V Relay, SPST 100 amp		148-014
SW736	12 V Relay, SPST 100 amp		148-014
SW741	12 V Relay, SPST 100 amp		148-014
SW742	12 V Relay, SPST 100 amp		148-014

Thermal Cutout

Tektronix
Part Number

TK601	Thermal Cutout 123°	260-246
-------	---------------------	---------

Transformers

T601	Base Step Power	*120-196
T701	Variable Auto	*120-189
T702	Collector Power	*120-197

Electron Tubes

V214	6AU6	154-022
V224	6AU6	154-022
V233	6DJ8	154-187
V254	6AU6	154-022
V264	6AU6	154-022

NOTES

NOTES

NOTES

NOTE

Unless otherwise specified, all of the voltage readings were taken with a dc vacuum-tube voltmeter having an input resistance of 11 megohms. The waveforms shown were reproduced from actual photographs. There will be considerable variation between instruments because of normal manufacturing tolerances and vacuum-tube characteristics. Therefore, the significance of any discrepancies observed should be determined by referring to the circuit diagram.

All readings are in volts unless otherwise specified. Where two voltage readings are given, they represent the voltage as read by a voltmeter under two sets of conditions, and, as such, do not indicate the peak-to-peak excursion of voltage at the point.

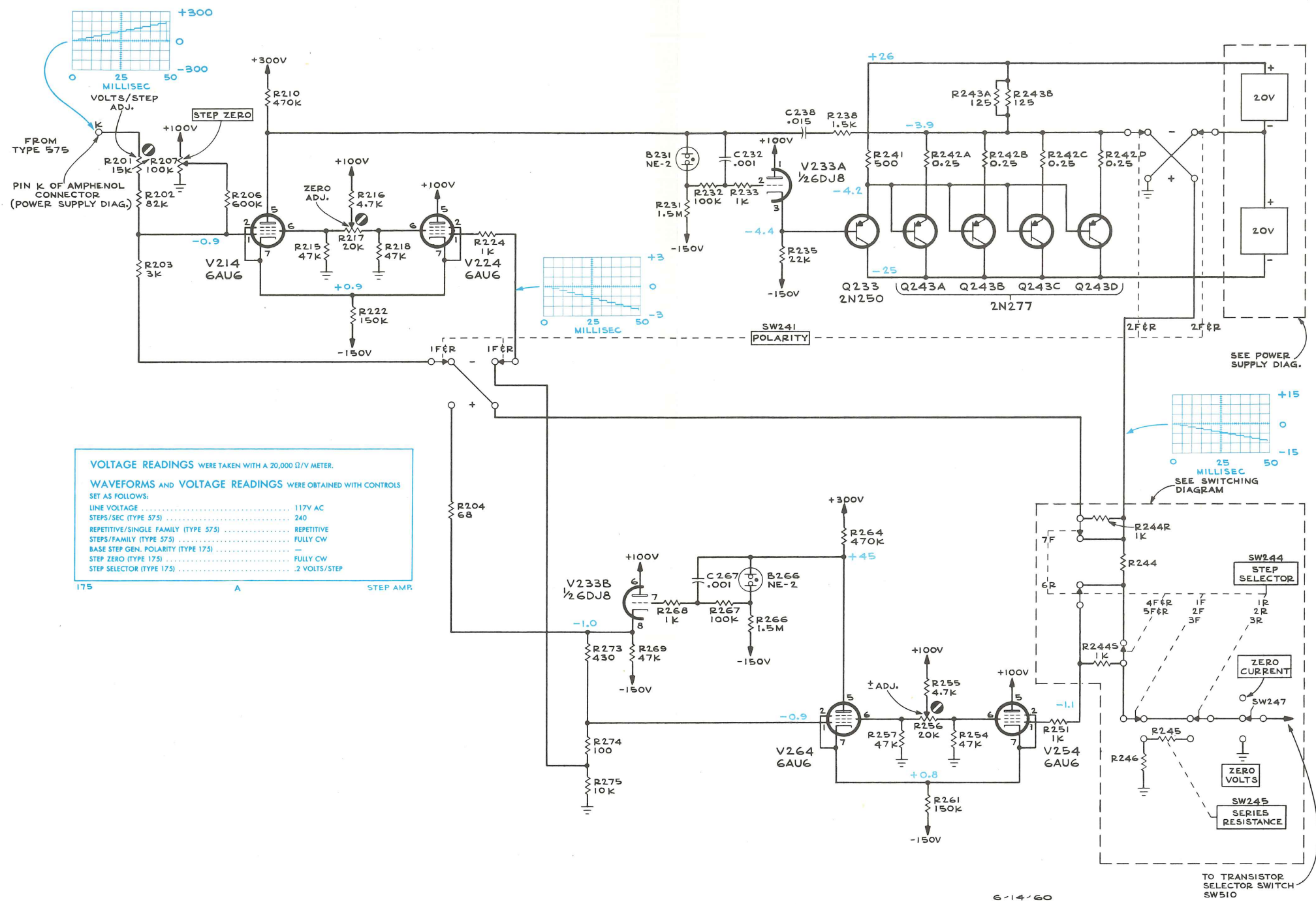

TYPE 175 TRANSISTOR-CURVE TRACER HIGH-CURRENT ADAPTOR

A

6-14-60
TP
STEP AMPLIFIER

TO TRANSISTOR
SELECTOR SWITCH
SW510

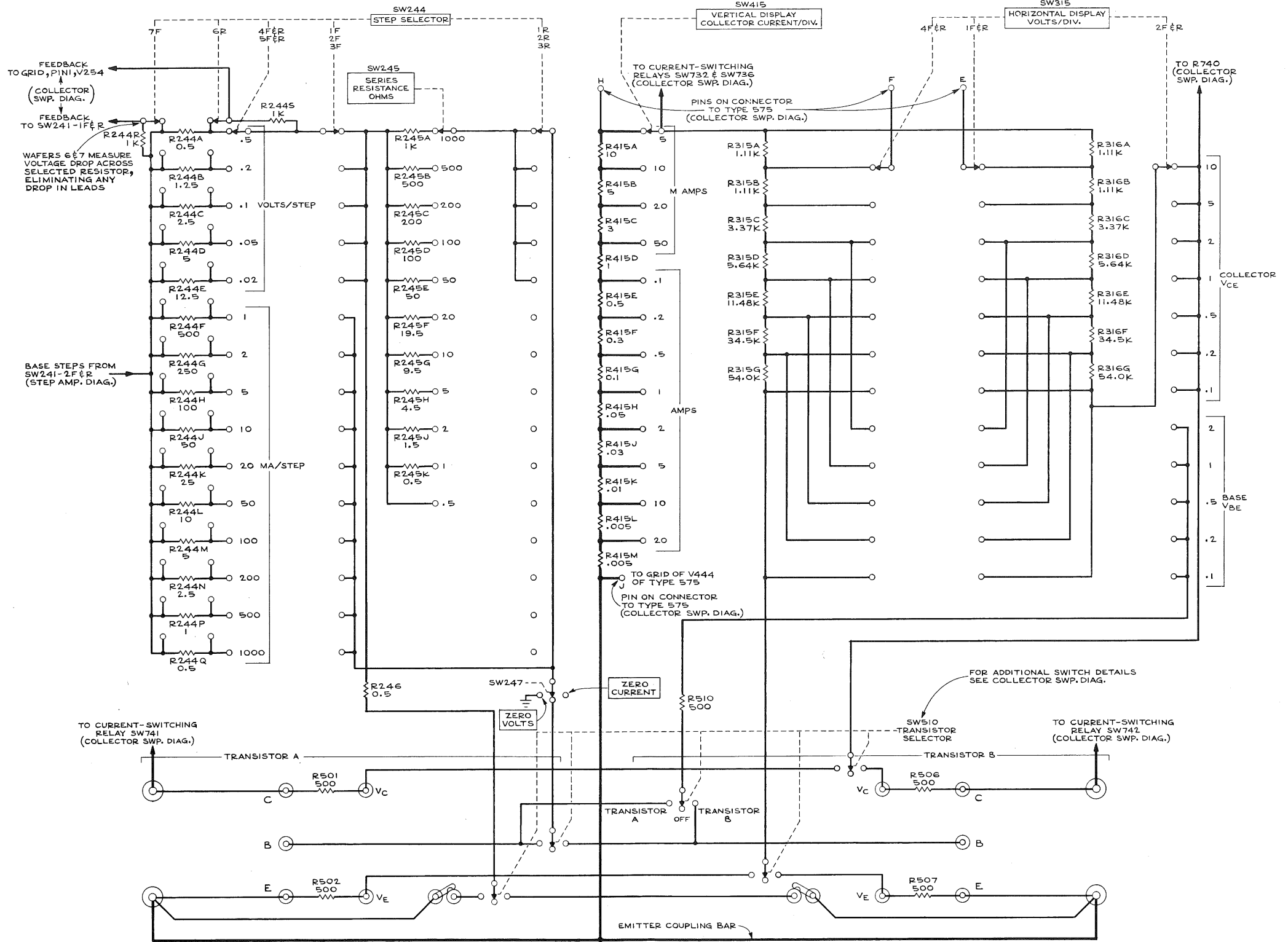

TYPE 175 TRANSISTOR-CURVE TRACER HIGH-CURRENT ADAPTOR

A

6-28-60
SWITCHING DIAGRAM
—TP—

SWITCHING DIAGRAM

NOTE

Unless otherwise specified, all of the voltage readings were taken with a dc vacuum-tube voltmeter having an input resistance of 11 megohms. The waveforms shown were reproduced from actual photographs. There will be considerable variation between instruments because of normal manufacturing tolerances and vacuum-tube characteristics. Therefore, the significance of any discrepancies observed should be determined by referring to the circuit diagram.

All readings are in volts unless otherwise specified. Where two voltage readings are given, they represent the voltage as read by a voltmeter under two sets of conditions, and, as such, do not indicate the peak-to-peak excursion of voltage at the point.

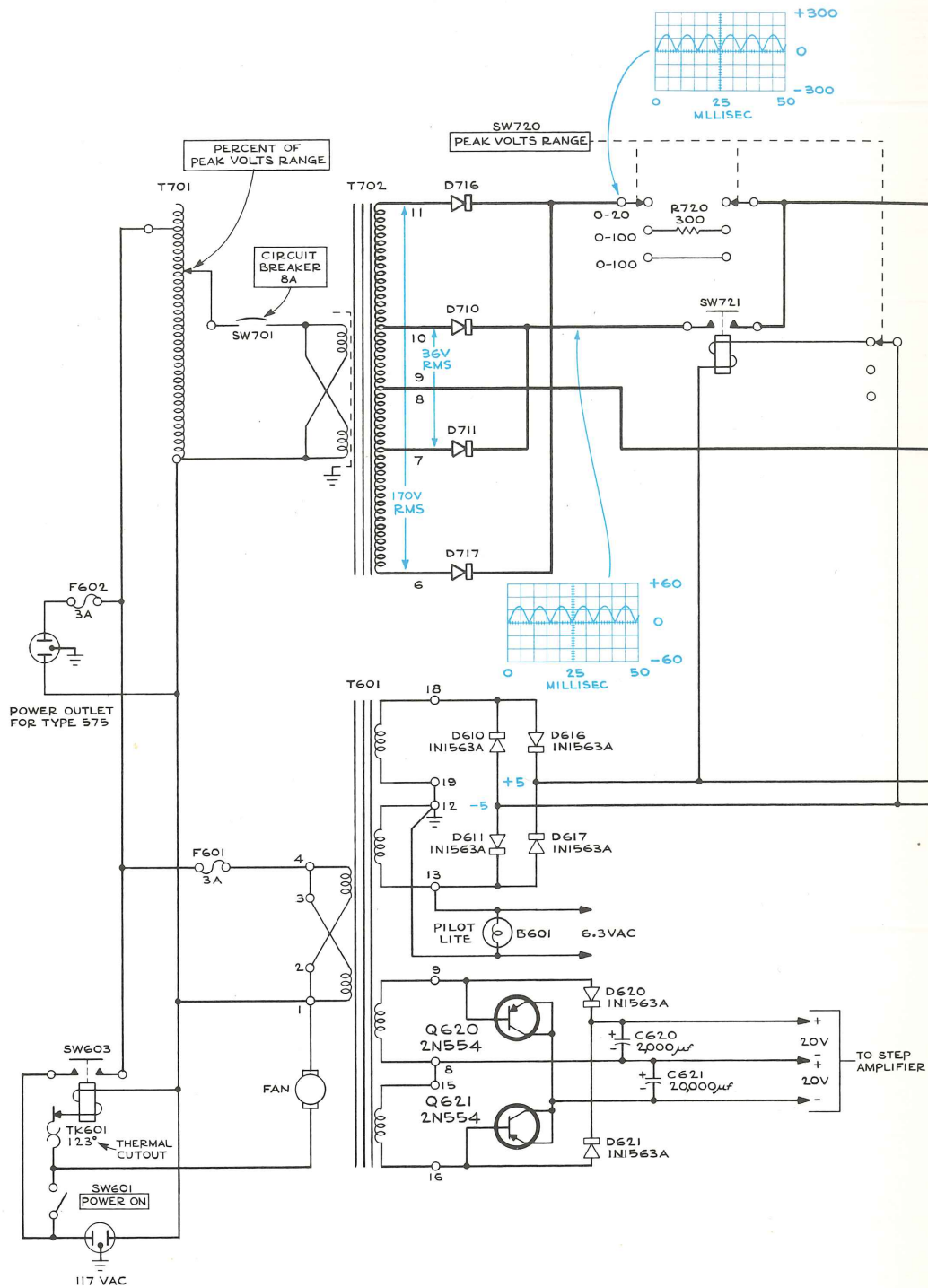

TYPE 175 TRANSISTOR-CURVE TRACER HIGH-CURRENT ADAPTOR

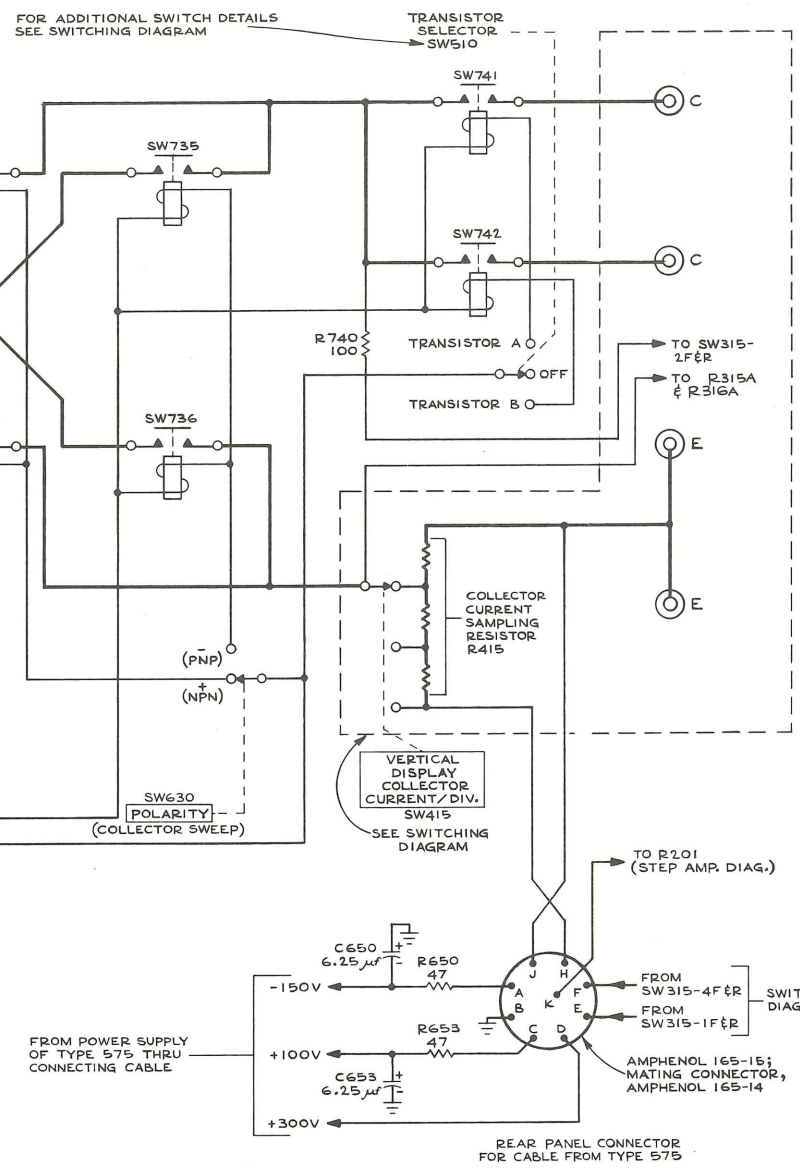

WAVEFORMS AND VOLTAGE READINGS WERE OBTAINED WITH CONTROLS SET AS FOLLOWS:
 LINE VOLTAGE 117 V
 PERCENT OF PEAK VOLTS RANGE FULLY CW

175 A COLLECTOR SWP. & POWER.

A COLLECTOR SWEEP & POWER SUPPLIES

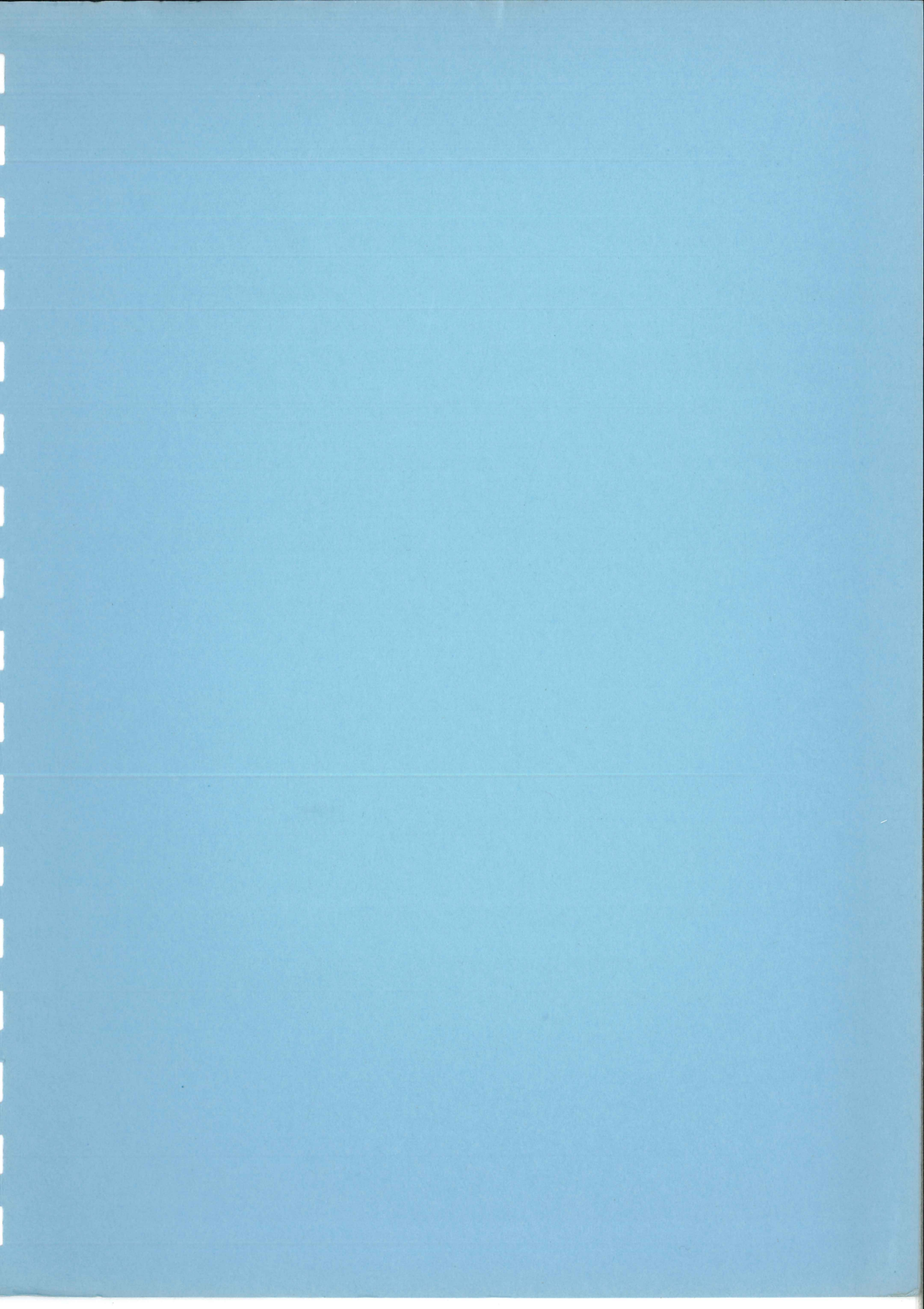

Tektronix, Inc., P.O. Box 500, Beaverton, Oregon
 Telephone: Mitchell 4-0161 TWX—BEAV 311 Cable: TEKTRONIX
 AN OREGON CORPORATION
 Field Engineering Offices

ALBUQUERQUE*	Tektronix, Inc., 509 San Mateo Blvd. N. E., Albuquerque, New Mexico	TWX—AQ 96	AMherst 8-3373
			Southern New Mexico Area: Enterprise 678
ATLANTA*	Tektronix, Inc., 3272 Peachtree Road, N. E., Atlanta 5, Georgia	TWX—AT 358	Cedar 3-4484
BALTIMORE*	Tektronix, Inc., 724 York Road, Towson 4, Maryland	TWX—TOWS 535	Valley 5-9000
BOSTON*	Tektronix, Inc., 442 Marcell Road, Lexington 73, Massachusetts	TWX—LEX MASS 940	Volunteer 2-7570
BUFFALO	Tektronix, Inc., 961 Maryvale Drive, Buffalo 25, New York	TWX—MVSV 2	NF 3-7861
CHICAGO*	Tektronix, Inc., 400 Higgins Road, Park Ridge 15, Illinois	PK RG 1395	Talcoff 5-6666
CLEVELAND	Tektronix, Inc., 1503 Brookpark Road, Cleveland 9, Ohio	TWX—CY 352	Florida 1-8414 Pittsburgh Area: Zenith 0212
DALLAS*	Tektronix, Inc., 6211 Denton Drive, P. O. Box 35104, Dallas 35, Texas	TWX—DL 264	Fleetwood 7-9128
DAYTON	Tektronix, Inc., 3601 South Dixie Drive, Dayton 39, Ohio	TWX—DY 363	AXminster 3-4175
DENVER	Tektronix, Inc., 2120 South Ash Street, Denver 22, Colorado	TWX—DN 879	SKYline 7-1249 Salt Lake Area: Zenith 381
DETROIT*	Tektronix, Inc., 27310 Southfield Road, Lathrup Village, Michigan	TWX—SFLD 938	Elgin 7-0040
ENDICOTT*	Tektronix, Inc., 3214 Watson Blvd., Endwell, New York	TWX—ENDCT 290	Pioneer 8-8291
GREENSBORO	Tektronix, Inc., 1838 Banking Street, Greensboro, North Carolina	TWX—GN 540	Broadway 4-0486
HOUSTON	Tektronix, Inc., 2605 Westgrove Lane, Houston 27, Texas	TWX—HO 743	MCHawk 7-8301, 7-8302
INDIANAPOLIS	Tektronix, Inc., 3937 North Keystone Ave., Indianapolis 5, Indiana	TWX—IP 361X	Liberty 6-2408, 6-2409
KANSAS CITY	Tektronix, Inc., 5920 Nall, Mission, Kansas	TWX—KC KAN 1112	HEdrick 2-1003 St. Louis Area: ENterprise 6510
LOS ANGELES AREA			
East L. A.	Tektronix, Inc., 5441 East Beverly Blvd., East Los Angeles 22, California	TWX—MTB 3855	RAYmond 3-9408
Encino	Tektronix, Inc., 17418 Ventura Blvd., Encino California	TWX—VNY5 5441	State 8-5170
*West L. A.	Tektronix, Inc., 11681 San Vicente Blvd., West Los Angeles 49, California	TWX—W L A 6698	BRadshaw 2-1563 CRanite 3-1105 WAlnut 7-9559
MINNEAPOLIS	Tektronix, Inc., 3100 W. Lake Street, Minneapolis 16, Minnesota	TWX—MP 983	
NEW YORK CITY AREA			
*New York City and Long Island served by:			
	Tektronix, Inc., 840 Willis Avenue, Albertson, L. I., New York	TWX—G CY NY 1416	Pioneer 7-4830
Westchester County, Western Connecticut, Hudson River Valley served by:			
	Tektronix, Inc., 1122 Main Street, Stamford, Connecticut	TWX—STAM 350	DAvis 5-3817
*Northern New Jersey served by:			
	Tektronix, Inc., 400 Chestnut Street, Union, New Jersey	TWX—UNVL 82	MURdock 8-2222
ORLANDO*	Tektronix, Inc., 205 East Colonial Drive, Orlando, Florida	TWX—OR 7008	GArden 5-3483
PALO ALTO*	Tektronix, Inc., 3944 Fabian Way, Palo Alto, California	TWX—PAL AL 110	DAvenport 6-8500
PHILADELPHIA*	Tektronix, Inc., 7709 Ogontz Ave., Philadelphia 50, Pennsylvania	TWX—PH 930	WAverly 4-5678
PHOENIX*	Tektronix, Inc., 7000 E. Camelback Road, Scottsdale, Arizona	TWX—SCSD 52	WHilney 6-4273
PORTLAND	Hawthorne Electronics, 700 S. E. Hawthorne Blvd., Portland 14, Oregon		BElmont 4-9375
POUGHKEEPSIE*	Tektronix, Inc., 8 Raymond Avenue, Poughkeepsie, New York	TWX—POUGH 5063	GRover 1-3620
SAN DIEGO	Tektronix, Inc., 3045 Rosecrans Street, San Diego 10, California		ACademy 2-0384
SEATTLE	Hawthorne Electronics, 112 Administration Bldg., Boeing Field, Seattle, Washington	TWX—SE 189 Parkway	5-1460
ST. PETERSBURG	Tektronix, Inc., 2330 Ninth Street South, St. Petersburg 5, Florida	TWX—ST PBG 8034	ORange 1-6139
SYRACUSE*	Tektronix, Inc., East Molloy Road and Pickard Drive, P. O. Box 155, Syracuse 11, New York	TWX—SS 423	GlENview 4-2426
TORONTO*	Tektronix, Inc., 3 Finch Ave., East, Willowdale, Ontario, Canada		Toronto, BAldwin 5-1138
WASHINGTON D. C.*	Tektronix, Inc., 9619 Columbia Pike, Annandale, Virginia	TWX—F CH VA 760	Clearbrook 6-7411

Tektronix, Inc., Victoria Avenue, St. Sampson's, Guernsey, Channel Isles
 Telephone: CENTRAL 3767 CABLE: TEK GUERNSEY TELEX 41-93

Overseas Representatives

AUSTRALIA	Electronic Industries Imports Pty. Ltd., Box 192 G.P.O., Melbourne C.1., Australia	FJ-4161/8
	Electronic Industries Imports Pty. Ltd., 90 Grote St., Adelaide, S.A., Australia	LA-5295
	Electronic Industries Imports Pty. Ltd., 376 Ann St., Brisbane, Q'land, Australia	B-6462
	Electronic Industries Imports Pty. Ltd., 68 Railway Pde., West Perth, W.A., Perth, Australia	BA-8587/9686
	Electronic Industries Imports Pty. Ltd., 121 Crown Street, East Sydney, Australia	FL-5041
AUSTRIA	Inglomark Markowitsch & Company, Mariahilfer Strasse 133, Wien 15, Austria	54-75-85-SERIE
BELGIUM	Regulation-Mesure, S.P.R.L., 22 rue Saint-Hubert, Bruxelles 15, Belgium	70-79-89
BRAZIL	Consulting & Suppliers Company for South America Inc., 61 Broadway, New York 6, New York	BOWling Green 9-0610
	Importacao Industria E Comercio Ambriex S.A., Av. Graca Aranha 226-601/6 Rio De Janeiro, Brazil	42-7990, 42-7291
	Palmar Ltda., Rua 7 de Abril 252, Sao Paulo, Brazil	34-4497
CUBA	Laboratorios Meditron, 41 #1063 entre Kohly y 32, Alturas del Vedado, Habana, Cuba	F-5970
DENMARK	Tage Olsen A/S, Centrumsgaarden, Room 133, 6D, Vesterbrogade, Kobenhavn V, Denmark	Palae 1369, Palae 1343
FINLAND	Into O/Y, 11 Meritullinkatu, Helsinki, Finland	62 14 25, 35 125
FRANCE	Maurice I. Parisier & Co., 741-745 Washington St., New York 14, N. Y.	Algoanquin 5-8900
	Relations Techniques Intercontinentales, 134 Avenue de Malakoff, Paris 16, France	Passy 08-36, Kleber 54-82
GREECE	Marios Dalleggio, 2, Rue Alopekis, Athens (K), Greece	70-669
INDIA	Electronic Enterprises, 46, Karani Building, Opp. Cama Baug., New Charni Road, Bombay 4, India	75376
ISRAEL	Landseas Products Corp., 48 West 48th Street, New York 36, New York	COLumbus 5-8323
	Landseas Eastern Co., Ltd., P. O. Box 2554, 22 Maze St., Tel Aviv, Israel	66890
ITALY	Silverstar, Ltd., 21 Via Visconti di Modrone, Milano, Italy	790.555
	Silverstar, Ltd., 12, Via Paisiello, Roma, Italy	868.046
	Silverstar, Ltd., c/o SICAR S.p.A., 3 Corso Matteotti, Torino Italy	524.021 524.071
JAPAN	Midariya Electric Co., Ltd., 3, 2-Chome, Kyobashi, Chuo-ku, Tokyo, Japan	561-9256
MEXICO	Cotesa, Apartado 2250, Mexico 1, D.F., Mexico	46-44-21
NETHERLANDS	C. N. Road, n.v., 11-13 Cort van der Lindenstraat, Rijswijk, Z.H., Netherlands	The Hague 98.51.53
NORWAY	Morgensierne & Company, Collets Gate 10, Oslo, Norway	60 17 90
PORTUGAL	Equipamentos de Laboratorio Lda., Rua Pedro Nunes, 47, Lisboa, Portugal	733436/733437
PUERTO RICO	International General Electric, P. O. Box 9387, Santurce, Puerto Rico	
SWEDEN	Erik Ferner AB, Snormakarvagen 35, Box 56, Bromma, Sweden	Stockholm 25 28 70
SWITZERLAND	Omni Ray AG, Dufourstrasse 56, Zurich 8, Switzerland	(051) 34-44-30
UNION OF SOUTH AFRICA	Protea Holdings, Ltd., Nucleonics Division, 9, Newton St. (P. O. Box 7793) Wemmer, Johannesburg, Union of South Africa	33.2211
UNITED KINGDOM	Livingston Laboratories Ltd., Retcar Street, London N.19, England	Archway 6251
URUGUAY	Compania Uruguaya De Rayos X y Electromedicina S. A. Mercedes 1300, Yaguaron 1449, Montevideo, Uruguay	8 58 29
WEST GERMANY	Rohde & Schwarz Vertriebs-GmbH., Hohe Strasse 160-168, Koeln, West Germany	23 30 06
	Rohde & Schwarz Vertriebs-GmbH., Augsburgstrasse 40, Berlin W30, West Germany	91 27 62
	Rohde & Schwarz Vertriebs-GmbH., Koernerstrasse 34, Hamburg, West Germany	27 41 41
	Rohde & Schwarz Vertriebs-GmbH., Kriegsstrasse 39, Karlsruhe, West Germany	2 52 02
	Rohde & Schwarz Vertriebs-GmbH., Brienner Strasse 43, Muenchen 2, West Germany	59 52 65

Other OVERSEAS areas please write or cable directly to the Export Department, P. O. Box 500, Beaverton, Oregon, U.S.A.