

INSTRUCTION MANUAL

Serial Number _____



Tektronix, Inc.

S.W. Millikan Way ● P. O. Box 500 ● Beaverton, Oregon 97005 ● Phone 644-0161 ● Cables: Tektronix

070-0617-00

667



WARRANTY

All Tektronix instruments are warranted against defective materials and workmanship for one year. Tektronix transformers, manufactured in our own plant, are warranted for the life of the instrument.

Any questions with respect to the warranty mentioned above should be taken up with your Tektronix Field Engineer.

Tektronix repair and replacement-part service is geared directly to the field, therefore all requests for repairs and replacement parts should be directed to the Tektronix Field Office or representative in your area. This procedure will assure you the fastest possible service. Please include the instrument Type and Serial or Model Number with all requests for parts or service.

Specifications and price change privileges reserved.

Copyright © 1967 by Tektronix, Inc., Beaverton, Oregon. Printed in the United States of America. All rights reserved. Contents of this publication may not be reproduced in any form without permission of the copyright owner.

CONTENTS

Section 1 Specification

Section 2 Operating Instructions

Section 3 Circuit Description

Section 4 Maintenance

Section 5 Performance Check

Section 6 Calibration

Abbreviations and Symbols

Parts Ordering Information

Section 7 Electrical Parts List

Mechanical Parts List Information

Section 8 Mechanical Parts List

Section 9 Diagrams

Accessories

Mechanical Parts List Illustrations

Section 10 Rackmounting

Abbreviations and symbols used in this manual are based on, or taken directly from, IEEE Standard 260 "Standard Symbols for Units", MIL-STD-12B and other standards of the electronics industry. Change information, if any, is located at the rear of this manual.

SEE PARTS LIST FOR SEMICONDUCTOR TYPES

SERIES M, MODEL 1, 2, 3

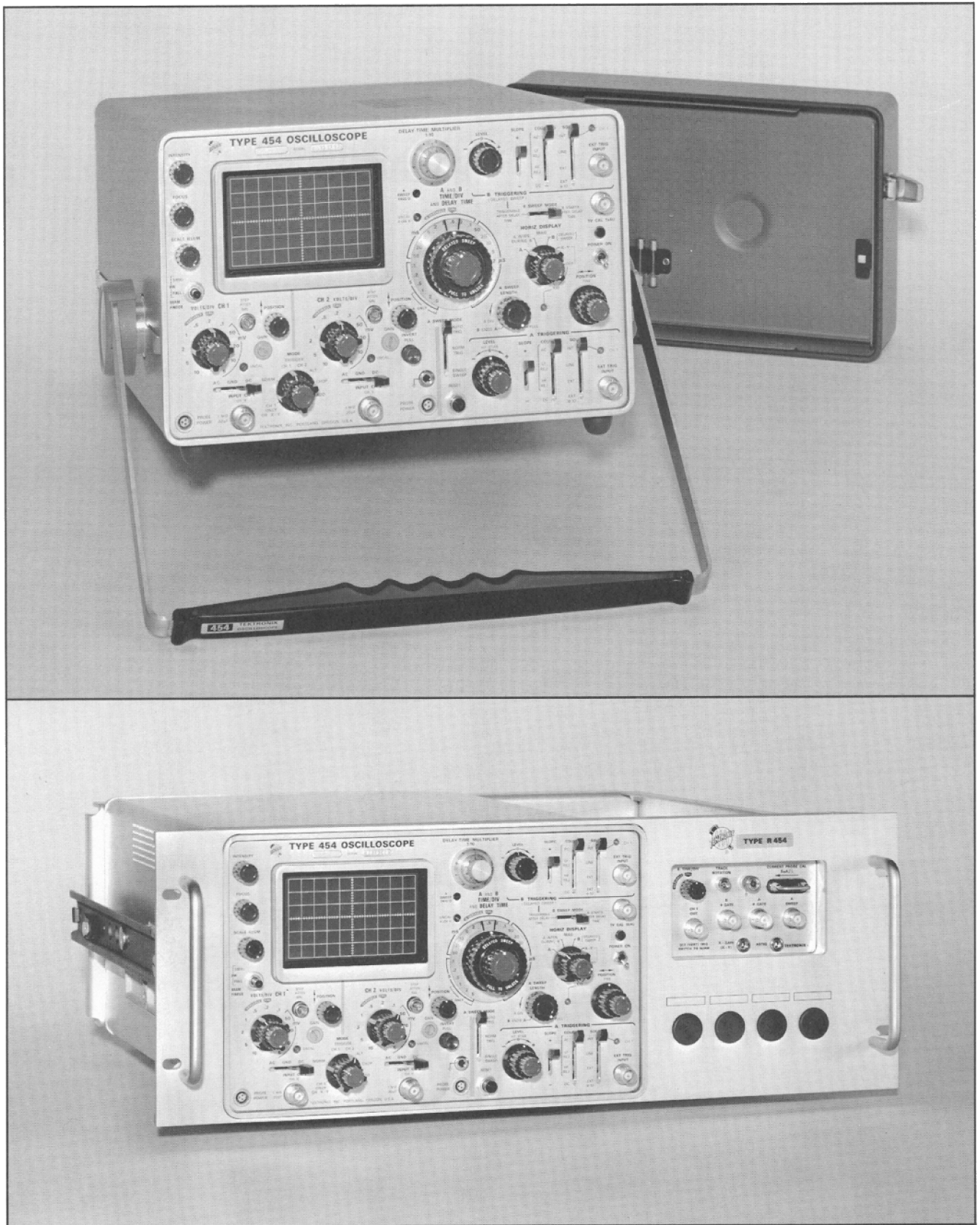

Fig. 1-1. Top; the Type 454 Oscilloscope. Bottom; the Type R454 Oscilloscope.

Type 454/R454

SECTION 1

TYPE 454/R454 SPECIFICATION

Introduction

The Tektronix Type 454 Oscilloscope is a wide bandwidth, portable oscilloscope designed to operate in a wide range of environmental conditions. The light weight and compact design of the Type 454 allow it to be easily transported, while providing the performance necessary for accurate high-frequency measurements. The dual-channel, DC-to-150 megahertz vertical system provides calibrated deflection factors from 5 millivolts to 10 volts/division (bandwidth is reduced at the two lowest deflection factors). Channels 1 and 2 can be cascaded using an external cable to provide a one millivolt minimum deflection factor. A bandwidth limit switch allows low-frequency, low-level signals to be viewed with reduced interference from signals above about six megahertz.

The trigger circuits provide stable triggering over the full range of vertical bandwidth. Separate trigger controls are provided to select the desired triggering for the A and B sweeps. One of three sweep modes can be selected for A sweep; automatic triggering, normal triggering or single sweep. The horizontal deflection system provides calibrated sweep rates from five seconds to 0.05 microsecond/division. A $\times 10$ magnifier allows each sweep rate to be increased 10 times to provide a maximum sweep rate of five nanoseconds/division in the $.05 \mu\text{s}$ position. The delayed sweep feature

allows the B sweep to be delayed a selected amount from the start of A sweep to provide accurate relative-time measurements. Calibrated X-Y measurements can be made with Channel 2 providing the vertical deflection and Channel 1 providing the horizontal deflection (TRIGGER switch set to CH 1 ONLY, HORIZ DISPLAY switch set to X-Y). The regulated DC power supplies assure that instrument performance is not affected by variations in line voltage and frequency. Total power consumption of the instrument is about 125 watts.

Information given in this instruction manual applies to the Type R454 also unless otherwise indicated. The Type R454 is electrically identical to the Type 454 but it is adapted for mounting in a standard 19-inch rack. Rackmounting instructions, a mechanical parts list and a dimensional drawing for the Type R454 are provided in section 10 of this manual.

This instrument will meet the electrical characteristics listed in Table 1-1 following complete calibration as given in Section 6. The performance check procedure given in Section 5 provides a convenient method to check instrument performance without making internal checks or adjustments. The following electrical characteristics apply over a calibration interval of 1000 hours and an ambient temperature range of -15°C to $+55^{\circ}\text{C}$, except as otherwise indicated. Warm-up time for given accuracy is 20 minutes.

TABLE 1-1
ELECTRICAL

| Characteristic | Performance |
|---|---|
| VERTICAL DEFLECTION SYSTEM | |
| Deflection Factor Channel 1 or 2 calibrated range Without probe | Five millivolts/division to 10 volts/division in 11 steps. Steps in 1-2-5 sequence. |
| With P6047 Probe | 50 millivolts/division to 100 volts/division in 11 steps. Steps in 1-2-5 sequence. |
| Channel 1 or 2 accuracy Without probe | Within 3% of indicated deflection with GAIN correctly adjusted at $.2 \text{ V/DIV}$. |
| With P6047 Probe | Within 3% of indicated deflection with GAIN correctly adjusted at 20 mV/DIV . |
| Added mode accuracy Uncalibrated (variable) range | Within 3% over calibrated range. Continuously variable between calibrated deflection factor settings. Extends maximum uncali- |

| Characteristic | Performance |
|---|--|
| | brated deflection factor to at least 25 volts/division. |
| Channels 1 and 2 cascaded (uncalibrated) | One millivolt/division minimum with signal connected to INPUT CH 1, CH 1 OUT connected to INPUT CH 2 through a 50-ohm 18-inch RG-58A/U BNC cable, CH 1 and 2 VOLTS/DIV switches set to 5 mV, MODE switch set to CH 2 and TRIGGER switch set to NORM. |
| Low-Frequency Linearity | 0.1 division or less compression or expansion of a center-screen two-division signal when positioned to the top and bottom of the graticule area. |
| Bandwidth at -3 dB Points with Four-division Reference (CH 1 and CH 2 VARIABLE controls set to CAL) | |
| BW-BEAM FINDER switch set to FULL (all vertical modes) | |
| DC input coupling | DC to upper limit defined in Table 1-1A. |

Specification—Type 454/R454

| Characteristic | Performance |
|--|--|
| AC input coupling | 10 hertz or less (one hertz or less with P6047 Probe) to upper limit defined in Table 1-1A. |
| BW-BEAM FINDER switch set to 5 MHz DC input coupling | DC to four megahertz or greater and six megahertz or less at all deflection factors. |
| AC input coupling | 10 hertz or less (one hertz or less with P6047 Probe) to four megahertz or greater and six megahertz or less at all deflection factors. |
| Attenuation ratio of signals greater than 65 megahertz with BW-BEAM FINDER switch set to 5 MHz | 10:1 or greater. |
| Step Response (CH 1 and CH 2 VARIABLE controls set to CAL, BW-BEAM FINDER switch set to FULL) Risetime (all vertical modes) | See Table 1-1A. |
| Aberrations (without probe, 25°C ±5°C) | Measured with positive-going step from 25-ohm source, CH 2 INVERT switch pushed in. All aberrations measured within area between one risetime and 50 nanoseconds after 50% point of step. |
| 5 mV/DIV | Peak aberrations not to exceed +7% or -7%; total peak-to-peak aberrations not to exceed 7%. |
| 10 mV/DIV | Peak aberrations not to exceed +6% or -6%; total peak-to-peak aberrations not to exceed 6%. |
| 20 mV/DIV | Peak Aberrations not to exceed +5% or -5%; total peak-to-peak aberrations not to exceed 5%. |

| Characteristic | Performance |
|--|--|
| 50 mV/DIV | Peak aberrations not to exceed +5% or -5%; total peak-to-peak aberrations not to exceed 5%. |
| 100 mV/DIV | Peak aberrations not to exceed +7% or -7%; total peak-to-peak aberrations not to exceed 7%. |
| Vertical Display Modes (selected by front-panel MODE switch) | Channel 1 only. Channel 2 only. Dual-trace, alternate between channels. Dual-trace, chopped between channels. Added algebraically. |
| Input Coupling Modes (selected by front-panel Input Coupling switch) | AC (capacitive) coupled or DC (direct) coupled. |
| Common-Mode Rejection Ratio, AC and DC Input Coupling | 10:1 or greater at 50 megahertz for common-mode signals 400 millivolts peak to peak or less in amplitude (with optimized setting of CH 1 and CH 2 GAIN adjustments at 50 mV/DIV and 50 megahertz). |
| Maximum Input Voltage, AC and DC Input Coupling | 600 volts (DC + peak AC). Peak-to-peak AC less than 600 volts (one kilohertz or less). |
| Input RC Characteristics | |
| Resistance | One megohm ±2%. |
| Capacitance | 20 picofarads ±1 pF. |
| Input Current | Two nanoamperes or less resulting in 0.4 division or less trace shift at 5 mV/DIV. |
| Step Attenuator Balance (all deflection factors) | One division or less trace shift when CH 1 or CH 2 VOLTS/DIV switch is changed to adjacent deflection factor setting. |
| Channel Isolation | 100:1 or greater at 50 megahertz. |
| Attenuator Isolation | 10,000:1 or greater at 50 megahertz. |

TABLE 1-1A

**Minimum Bandwidth and Maximum Risetime
(0° C to +40° C)**

| Deflection Factor | With P6047 Probe or 25-ohm source | With P6045 Probe | With P6048 Probe |
|---|-----------------------------------|----------------------------------|----------------------------------|
| 20 mV/DIV to 10 VOLTS/DIV | 150 megahertz 2.4 nanoseconds | 130 megahertz 2.7 nanoseconds | 100 megahertz 3.5 nanoseconds |
| 10 mV/DIV | 100 megahertz 3.5 nanoseconds | 95 megahertz 3.7 nanoseconds | 75 megahertz 4.7 nanoseconds |
| 5 mV/DIV | 60 megahertz 5.9 nanoseconds | 58 megahertz 6 nanoseconds | 45 megahertz 7.8 nanoseconds |
| 1 mV/DIV (Channels 1 and 2 cascaded) ¹ | 33 megahertz 11 nanoseconds | 30 megahertz 12 nanoseconds | 30 megahertz 12 nanoseconds |

¹Signal connected to INPUT CH 1, CH 1 OUT connected to INPUT CH 2 with a 50-ohm 18-inch RG-58A/U BNC cable, CH 1 and CH 2 VOLTS/DIV switches set to 5 mV, MODE switch set to CH 2 and TRIGGER switch set to NORM.

| Characteristic | Performance |
|---|--|
| Chopped Mode Repetition rate | One megahertz $\pm 20\%$. |
| Time segment from each channel | 0.25 nanoseconds or less. |
| Polarity Inversion (selected by CH 2 INVERT switch) | Displayed signal from Channel 2 can be inverted. |
| Delay line | Permits viewing of leading edge of triggering signal (internal triggering only). |

TRIGGERING (A AND B SWEEP)

| | |
|--|--|
| Trigger Source (selected by front-panel SOURCE switch) | Internal from displayed channel(s) or from Channel 1 only (as selected by front-panel TRIGGER switch). Internal from AC power source. External from signal applied to EXT TRIG INPUT connector. External from signal applied to EXT TRIG INPUT connector with 10 times attenuation. |
| Trigger Coupling (selected by front-panel COUPLING switch) | AC (capacitive) coupled. AC (capacitive) coupled with attenuation of low-frequency signals. AC (capacitive) coupled with attenuation of high-frequency signals. DC (direct) coupled. |
| Trigger Polarity (selected by front-panel SLOPE switch) | Sweep can be triggered from the positive-going or negative-going portion of trigger signal. |
| Trigger Level | LEVEL control allows selection of the triggering point on the selected slope of the trigger signal. |
| Trigger Sensitivity Internal | See Fig. 1-2. |
| External | See Fig. 1-3. |
| Auto Triggering (A sweep only) | Stable display presented with signal amplitudes within limits given in Figs. 1-2 and 1-3 above about 20 hertz with correct adjustment of the A LEVEL control. Free-running display for lower frequencies or in absence of an adequate trigger signal. |
| Single Sweep (A sweep only) | Trigger sensitivity same as defined in Figs. 1-2 and 1-3. A Sweep Generator produces only one sweep when triggered; further sweeps are locked out until RESET button is pressed. |
| Trigger Jitter | One nanosecond or less at 150 megahertz. |
| External Trigger Input RC characteristics SN B010100 to SN B219999 | One megohm $\pm 10\%$ paralleled by 20 picofarads ± 5 pF in all A and B COUPLING switch positions except LF REJ. Fig. 1-4 shows the equivalent input circuit in the LF REJ positions. |

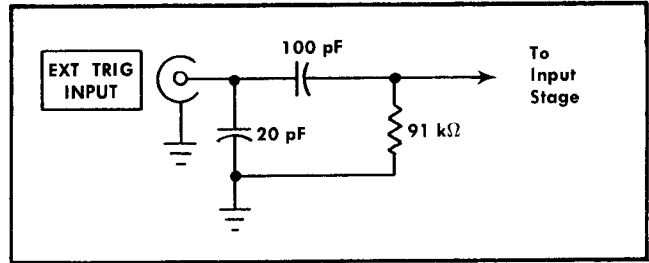

Fig. 1-4.

| Characteristic | Performance |
|----------------------------|---|
| Above SN B220000 | One megohm $\pm 10\%$ paralleled by 27 picofarads ± 5 pF in all A and B COUPLING switch positions except LF REJ. Fig. 1-4 shows the equivalent input circuit in the LF REJ positions. |
| Maximum input voltage | 500 volts DC + peak AC. Peak-to-peak AC less than 500 volts (one kilohertz or less). |
| LEVEL control range EXT | Greater than + and - two volts. |
| EXT $\div 10$ | Greater than + and - 20 volts. |

TIME BASE (A and B SWEEPS)

| | |
|---|--|
| Sweep Rate Calibrated range, MAG switch set to OFF | |
| A sweep | Five seconds to 0.05 microsecond/division in 25 steps. Steps in 1-2-5 sequence. |
| B sweep | 50 milliseconds to 0.05 microsecond/division in 22 steps. Steps in 1-2-5 sequence. |
| Calibrated range, MAG switch set to $\times 10$ | |
| A sweep | 0.5 second to five nanoseconds/division in 25 steps. Steps in 1-2-5 sequence. |
| B sweep | 50 milliseconds to five nanoseconds/division in 22 steps. Steps in 1-2-5 sequence. |
| Uncalibrated (variable) range | Continuously variable between calibrated sweep rate settings. Extends slowest uncalibrated sweep rate to at least 12.5 seconds/division for A sweep or at least 1.25 seconds/division for B sweep. |
| Sweep Accuracy (A VARIABLE and B TIME/DIV VARIABLE controls set to CAL) | See Table 1-1B. |
| Sweep Length A sweep | Variable from four divisions or less to 11.0 divisions ± 0.5 division. |

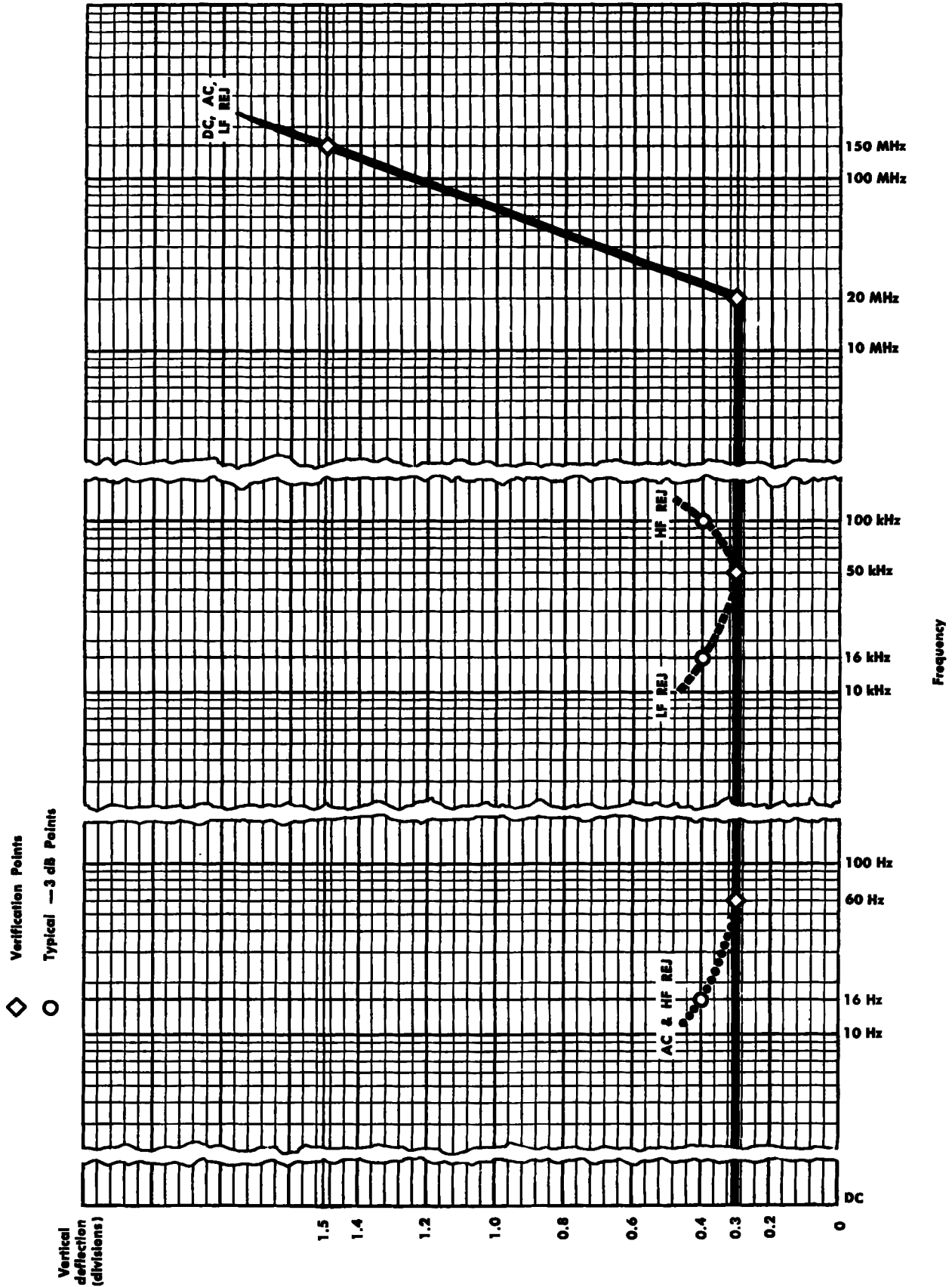

Fig. 1-2. Internal trigger sensitivity specification limit curve.

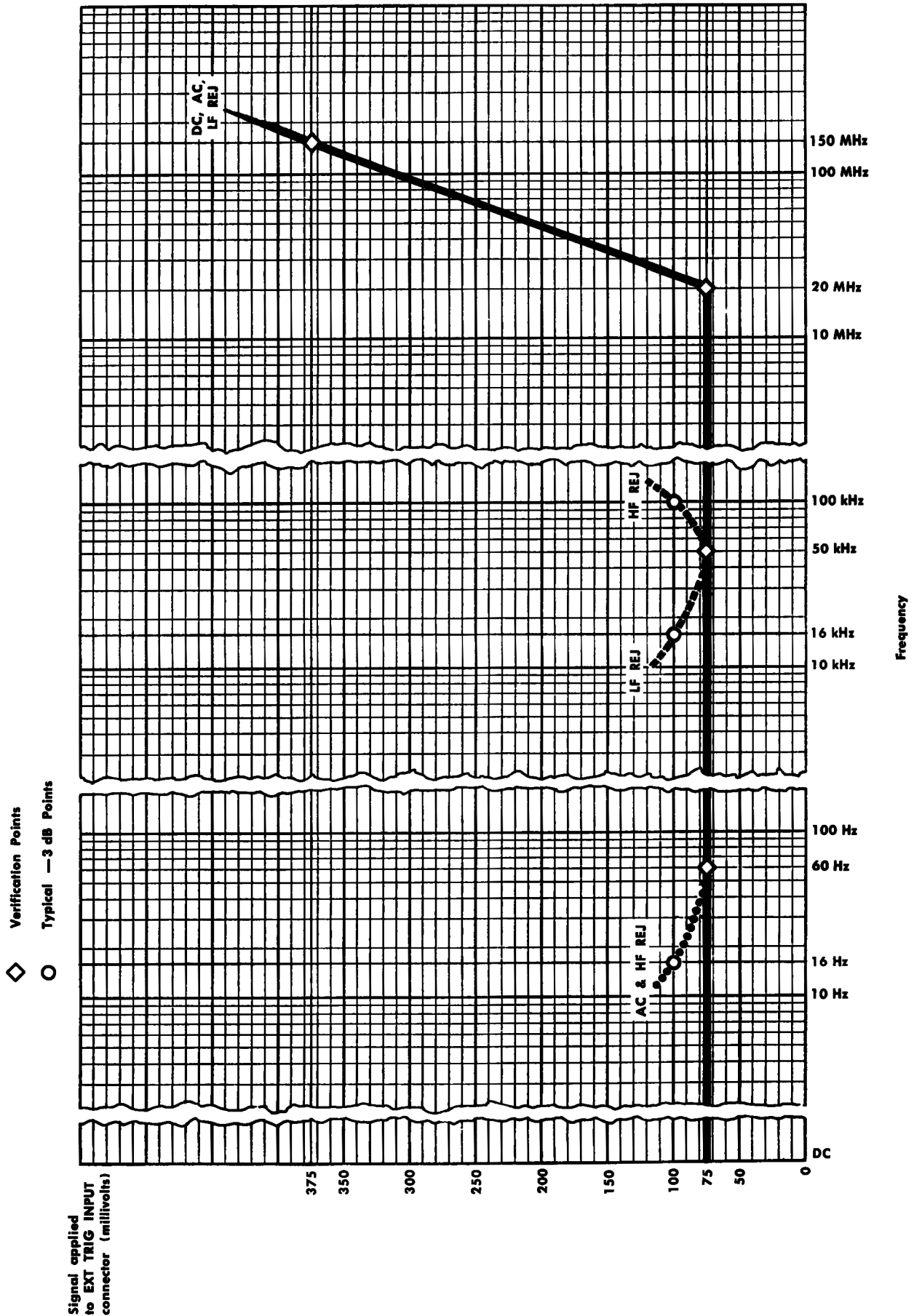

Fig. 1-3. External trigger sensitivity specification limit curve.

TABLE 1-1B
Sweep Accuracy

| A and B TIME/DIV switch setting | 0° C to +40° C | | -15° C to +55° C | |
|---|----------------|------------------------|------------------|------------------------|
| | Unmagnified | Magnified ² | Unmagnified | Magnified ² |
| Over center eight divisions | Within 3% | Within 4% | Within 5% | Within 6% |
| 5 s to 1 s/DIV (A sweep only) | | | Within 4% | Within 5% |
| 0.5 s to 0.1 μs/DIV | | | Within 4% | Within 6% |
| 0.05 μs/DIV | | | | |
| Over any two division portion within center eight divisions (all sweep rates) | Within 5% | Within 5% | Within 5% | Within 10% |

²Exclude following portions of total magnified sweep length (equivalent magnified sweep rates given): 20 nanoseconds/division, first 3.5 and last 1.5 divisions; 10 nanoseconds/division, first seven and last four divisions; five nanoseconds/division, first 14 and last seven divisions.

| Characteristic | Performance |
|-----------------------------------|--|
| B sweep | 11.0 divisions ±0.5 division. |
| Sweep Holdoff Time (A sweep only) | One times or less the A TIME/DIV switch setting. |
| 5 s to 0.1 ms/DIV | |
| 50 μs to 1 μs/DIV | Two times or less the A TIME/DIV switch setting with HF STAB control set fully counterclockwise. |
| 0.5 μs to 0.05 μs/DIV | Two microseconds or less with HF STAB control set fully counterclockwise. |

DELAYED SWEEP

| | | |
|--|--|------------------|
| Delay Time | Continuously variable from 50 seconds to one microsecond. Delay time determined by A TIME/DIV switch setting multiplied by DELAY-TIME MULTIPLIER dial setting. | |
| Calibrated range (A VARIABLE control set to CAL) | | |
| Accuracy | 0° C to +40° C | |
| | | -15° C to +55° C |
| 5 s to 0.1 s/DIV | Within 2.5%. | Within 3.5%. |
| 50 ms to 1 μs/DIV | Within 1.5%. | Within 2%. |
| Incremental multiplier linearity | Within 0.2%. | Within 0.3%. |
| Jitter | One part or less in 20,000 of the maximum available delay time (10 times the A TIME/DIV switch setting). | |
| DELAY-TIME MULTIPLIER Dial Range | 0.1 to 10.1 times the A TIME/DIV switch setting. | |

X-Y OPERATION

| | |
|-------------------|--|
| Deflection Factor | Five millivolts to 10 volts/division in 11 steps. Steps in 1-2.5 sequence. CH 1 VARIABLE and horizontal POSITION controls inoperative in X-Y position of HORIZ DISPLAY switch. |
| Calibrated range | |
| Accuracy | Within 3%. |

| Characteristic | Performance |
|---|---|
| X Bandwidth at Upper -3 dB-Point, AC (capacitive) and DC (direct) coupled, with Four-Division Reference | Two megahertz or greater. |
| Phase shift between X and Y Amplifiers | 3° or less from DC to two megahertz with MAG switch set to OFF. |
| X and Y Input Characteristics | See Vertical Deflection System characteristics. |
| Maximum input voltage | |
| Input RC characteristics | |
| Input coupling | |

CALIBRATOR

| | | |
|-------------------|---|------------------|
| Waveshape | Square wave. | |
| Polarity | Positive going with baseline at zero volts. | |
| Output Voltage | One volt peak to peak. | |
| Output Current | Five milliamperes through CURRENT PROBE CAL loop on side panel. | |
| Repetition Rate | One kilohertz | |
| Accuracy | 0° C to +40° C | |
| | | -15° C to +55° C |
| Voltage | Within 1%. | Within 1.5%. |
| Current | Within 1%. | Within 1.5%. |
| Repetition rate | Within 0.5%. | Within 1%. |
| Risetime | One microsecond or less. | |
| Duty Cycle | 49% to 51%. | |
| Output Resistance | 250 ohms ±1%. | |

Z AXIS INPUT

| | |
|------------------------|---|
| Sensitivity | Five volt peak-to-peak signal produces noticeable modulation at normal intensity. |
| Polarity of Operation | Positive-going signal decreases trace intensity; negative-going signal increases trace intensity. |
| Usable Frequency Range | DC to 50 megahertz. |

| Characteristic | Performance |
|-----------------------|---|
| Maximum Input Voltage | 200 volts, DC + peak AC. Peak-to-peak AC must not exceed 200 volts (one kilohertz or less). |

SIGNAL OUTPUTS

| | |
|--|---|
| A Sweep | |
| Waveshape | Sawtooth. |
| Polarity | Positive going with baseline near zero volts. |
| Output voltage | 10 volts peak to peak. |
| Voltage accuracy | Within 10%. |
| Duration | Same as A sweep (variable with the A SWEEP LENGTH control). |
| A and B Gates | |
| Waveshape | Rectangular. |
| Polarity | Positive going with baseline at about -0.6 volt. |
| Output voltage | 12.6 volts peak to peak. |
| Voltage accuracy | Within 10%. |
| Duration | Same duration as respective sweep. |
| Vertical Signal Out (CH 1 only) | |
| Output voltage | 25 millivolts or greater for each division of CRT display (into one-megohm load). |
| Bandwidth at upper -3 dB point, AC (capacitive) or DC (direct) coupled | 33 megahertz or greater. |

POWER SUPPLY

| | | | |
|---|--|--------------------|--------------------|
| Line Voltage Range (AC, RMS) | Line voltage and range selected by Line Voltage Selector assembly on rear panel. | | |
| 115-volts nominal | 90 to 110 volts. | 104 to 126 volts. | 112 to 136 volts. |
| 230-volts nominal | 180 to 220 volts. | 208 to 252 volts. | 224 to 272 volts. |
| Line Frequency | 48 to 440 hertz. | | |
| Maximum Power Consumption | 48 hertz | 60 hertz | 440 hertz |
| Line Selector switch set to LO, 90 volts applied | 115 watts 1.5 A | 110 watts 1.4 A | 100 watts 1.3 A |
| Line Selector switch set to M, 115 volts applied | 130 watts 1.4 A | 125 watts 1.3 A | 115 watts 1.2 A |
| Line Selector switch set to HI, 136 volts applied | 145 watts 1.3 A | 140 watts 1.2 A | 130 watts 1.2 A |

CATHODE-RAY TUBE (CRT)

| | |
|----------------|---------------------------------------|
| Graticule Type | Internal with variable edge lighting. |
|----------------|---------------------------------------|

| Characteristic | Performance |
|--|---|
| Area | Six divisions vertical by 10 divisions horizontal. Each division equals 0.8 centimeter. |
| Resolution | |
| Horizontal | 15 lines or greater in one division. |
| Vertical | 15 lines or greater in one division. |
| Geometry | 0.1 division or less total. |
| Beam Finder | Limits display within graticule area when pressed. |
| Photographic Writing Speed (without film fogging techniques) | |
| Tektronix C31 Camera with f1.2 lens and 1:0.5 object-to-image ratio | |
| P31 CRT phosphor | At least 1600 divisions/microsecond (1280 centimeters/microsecond) with Polaroid ³ Type 410 film (10,000 ASA). |
| P11 CRT phosphor | At least 3200 divisions/microsecond (2560 centimeters/microsecond) with Polaroid Type 410 film (10,000 ASA). |
| Tektronix C30A Camera with f1.9 lens and 1:0.7 object-to-image ratio | |
| P31 CRT phosphor | At least 182 divisions/microsecond (146 centimeters/microsecond) with Polaroid Type 107 film (3000 ASA). |
| Tektronix C40 Camera with f1.3 lens and 1:0.5 object-to-image ratio | |
| P31 CRT phosphor | At least 1250 divisions/microsecond (1000 centimeters/microsecond) with Polaroid Type 410 film (10,000 ASA). |
| P11 CRT phosphor | At least 2500 divisions/microsecond (2000 centimeters/microsecond) with Polaroid Type 410 film (10,000 ASA). |

TABLE 1-2

ENVIRONMENTAL

| Characteristic | Performance |
|---|-----------------|
| NOTE | |
| This instrument will meet the electrical characteristics given in Table 1-1 over the following environmental limits. Complete details on environmental test procedures, including failure criteria, etc., can be obtained from Tektronix, Inc. Contact your local Tektronix Field Office or representative. | |
| Temperature | |
| Operating | -15°C to +55°C. |
| Non-operating | -55°C to +75°C. |

³Registered trademark of the Polaroid Corporation.

Specification—Type 454/R454

| Characteristic | Performance |
|---|--|
| Altitude | |
| Operating | 15,000 feet maximum. Maximum operating temperature decreases 1°C/1000 feet increase in altitude between 5000 and 15,000 feet. |
| Non-operating | Test limit 50,000 feet. |
| Humidity | |
| Non-operating | Five cycles (120 hours) of Mil-Std-202C, Method 106B. Omit freezing and vibration. Allow a 24 hour post-test drying period at +25°C ±5°C and 20% to 80% relative humidity. |
| Vibration | |
| Operating and non-operating | 15 minutes along each of the three major axes at a total displacement of 0.025 inch peak to peak (4g at 55 c/s) with frequency varied from 10-55-10 c/s in one minute cycles. Hold at 55 c/s for three minutes on each axis. |
| Shock | |
| Operating and non-operating | Two guillotine-type shocks of 30 g, one-half sine, 11-millisecond duration each direction along each major axis. Total of 12 shocks. |
| Electromagnetic Interference (EMI) as Tested in Mil-I-6181D and Mil-I-16910C, Mod 163D only | |
| Radiated interference | Interference radiated from the instrument under test within the given limits from 14 kilohertz to 1000 megahertz (with mesh CRT filter installed). |
| Conducted interference | Interference conducted out of the instrument under test through the power cord within the given limits from 150 kilohertz to 30 megahertz. |
| Transportation | |
| Packaged instrument | Qualifies under National Safe Transit Committee test procedure 1A. |

**TABLE 1-3
PHYSICAL**

| Characteristics | Performance |
|---|--|
| Ventilation | Safe operating temperature is maintained by forced-air cooling. Automatic resetting thermal cutout protects instrument from overheating. |
| Warm-up Time | 20 minutes for rated accuracy. |
| Finish | |
| Type 454 | Anodized front panel. Blue vinyl-coated aluminum cabinet. |
| Type R454 | Anodized front panel. Anodized aluminum cabinet. |
| Overall Dimensions (measured at maximum points) | |
| Type 454 | |
| Height | 7 ¹ / ₄ inches (18.4 centimeters). |
| Width | 12 ¹ / ₂ inches (30.8 centimeters). |
| Depth (including front cover) | 20 ¹ / ₂ inches (52 centimeters). |
| Depth (handle positioned for carrying) | 22 ³ / ₈ inches (56.8 centimeters). |
| Type R454 | |
| Height | 7 inches (17.8 centimeters). |
| Width | 19 inches (48.3 centimeters). |
| Depth (behind front panel) | 17 ³ / ₄ inches (45 centimeters). |
| Depth (total) | 19 ⁹ / ₁₆ inches (48.7 centimeters). |
| Weight | |
| Type 454 | |
| Without front cover | Approximately 29 ¹ / ₄ pounds (12.7 kilograms). |
| With front cover and accessories | Approximately 31 ¹ / ₄ pounds (13.6 kilograms). |
| Type R454 | Approximately 33 ¹ / ₂ pounds (14.5 kilograms). |

STANDARD ACCESSORIES

Standard accessories supplied with the Type 454 and R454 are listed on the last pullout page of the Mechanical Parts List illustrations. For optional accessories available for use with this instrument, see the Tektronix, Inc. catalog.

SECTION 2

OPERATING INSTRUCTIONS

General

To effectively use the Type 454, the operation and capabilities of the instrument must be known. This section describes the operation of the front-, side- and rear-panel controls and connectors, gives first time and general operating information and lists some basic applications for this instrument.

Front Cover and Handle

The front cover furnished with the Type 454 provides a dust-tight seal around the front panel. Use the cover to protect the front panel when storing or transporting the instrument. The cover also provides storage space for probes and other accessories (see Fig. 2-1).

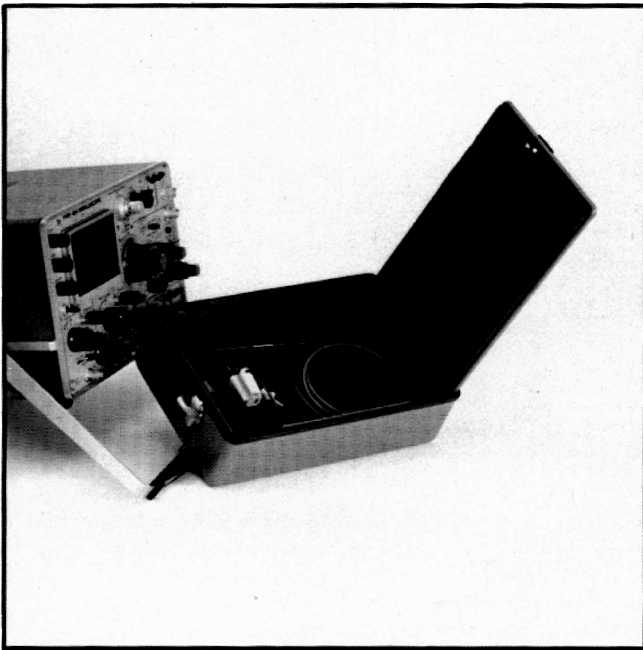

Fig. 2-1. Accessory storage provided in front cover.

The handle of the Type 454 can be positioned for carrying or as a tilt-stand for the instrument. To position the handle, press in at both pivot points (see Fig. 2-2) and turn the handle to the desired position. Fourteen positions are provided for convenient carrying or viewing. The instrument may also be set on the rear feet either for operation or storage.

Operating Voltage

The Type 454 can be operated from either a 115-volt or a 230-volt nominal line voltage source. The Line Voltage

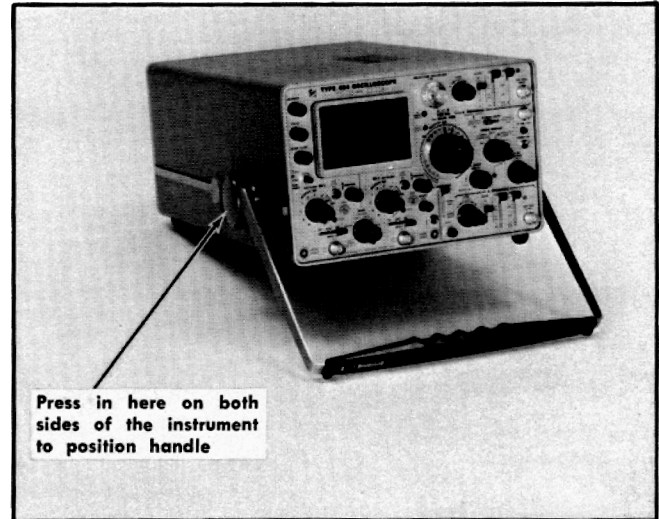

Fig. 2-2. Handle positioned to provide a stand for the instrument.

Selector assembly on the rear panel converts the instrument from one operating range to the other. In addition, this assembly changes the primary connections of the power transformer to allow selection of one of three regulating ranges. The assembly also includes the two line fuses. When the instrument is converted from 115-volt to 230-volt nominal operation or vice versa, the assembly connects or disconnects one of the fuses to provide the correct protection for the instrument. Use the following procedure to convert this instrument between nominal line voltages or regulating ranges.

1. Disconnect the instrument from the power source.
2. Loosen the two captive screws which hold the cover onto the voltage selector assembly; then pull to remove the cover.
3. To convert from 115-volts nominal to 230-volts nominal line voltage or vice versa, pull out the Voltage Selector switch bar (see Fig. 2-3); turn it 180° and plug it back into the remaining holes. Change the line-cord power plug to match the power-source receptacle or use a 115- to 230-volt adapter.
4. To change regulating ranges, pull out the Range Selector switch bar (see Fig. 2-3); slide it to the desired position and plug it back in. Select a range which is centered about the average line voltage to which the instrument is to be connected (see Table 2-1).
5. Re-install the cover and tighten the two captive screws.
6. Before applying power to the instrument, check that the indicating tabs on the switch bars are protruding through the correct holes for the desired nominal line voltage and regulating range.

Operating Instructions—Type 454/R454

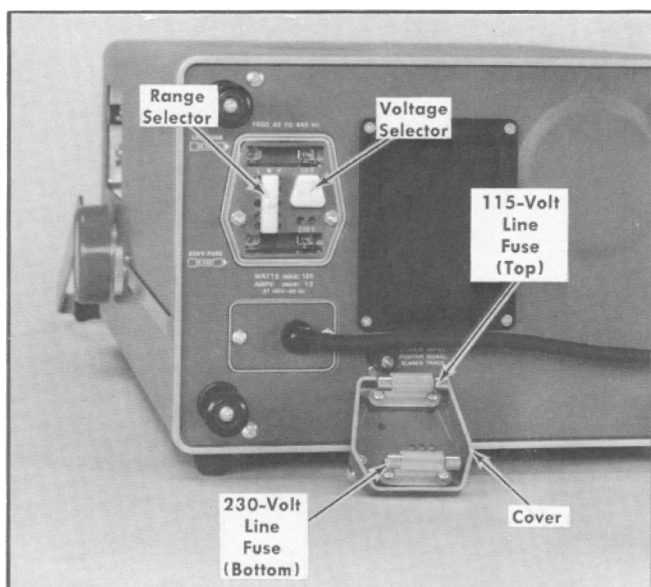

Fig. 2-3. Line Voltage Selector assembly on the rear panel (shown with cover removed).

CAUTION

The Type 454 should not be operated with the Voltage Selector or Range Selector switches in the wrong position for the line voltage applied. Operation of the instrument with the switches in the wrong positions will either provide incorrect operation or damage the instrument.

TABLE 2-1

Regulating Ranges

| Range Selector Switch Position | Regulating Range | |
|--------------------------------|-------------------|-------------------|
| | 115 Volts Nominal | 230 Volts Nominal |
| LO (switch bar in left holes) | 90 to 110 volts | 180 to 220 volts |
| M (switch bar in middle holes) | 104 to 126 volts | 208 to 252 volts |
| HI (switch bar in right holes) | 112 to 136 volts | 224 to 272 volts |

Operating Temperature

The Type 454 is cooled by air drawn in at the rear and blown out through holes in the top and bottom covers. Adequate clearance on the top, bottom and rear must be provided to allow heat to be dissipated away from the instrument. The clearance provided by the feet at the bottom and rear should be maintained. If possible, allow about one inch clearance on the top. Do not block or restrict the air flow from the air escape holes in the cabinet.

A thermal cutout in this instrument provides thermal protection and disconnects the power to the instrument if the internal temperature exceeds a safe operating level. Operation of the instrument for extended periods without the covers

may cause it to overheat and the thermal cutout to open more frequently. The air filter should be cleaned occasionally to allow the maximum amount of cooling air to enter the instrument. Cleaning instructions are given in Section 4.

The Type 454 can be operated where the ambient air temperature is between -15°C and $+55^{\circ}\text{C}$. The maximum operating temperature must be derated 1°C for each additional 1000 feet of altitude above 5000 feet. This instrument can be stored in ambient temperatures between -35°C and $+75^{\circ}\text{C}$. After storage at temperatures beyond the operating limits, allow the chassis temperature to come within the operating limits before power is applied.

Rackmounting

Complete information for mounting the Type R454 in a cabinet rack is given in Section 10 of this manual.

CONTROLS AND CONNECTORS

A brief description of the function and operation of the front-, side- and rear-panel controls and connectors follows. Fig. 2-4 shows the front, side and rear panels of this instrument. More detailed information is given in this section under General Operating Information.

Cathode-Ray Tube

| | |
|------------------|--|
| INTENSITY | Controls brightness of display. |
| FOCUS | Provides adjustment for optimum display definition. |
| SCALE ILLUM | Controls graticule illumination. |
| BW - BEAM FINDER | Three position switch which provides bandwidth limiting and beam location. |
| | 5 MHz: Vertical Amplifier bandwidth limited to provide a reduction in displayed noise or interference. |
| | FULL: Normal operation with full Vertical Amplifier bandwidth capabilities. |
| | BEAM FINDER: Compresses display within graticule area, independently of display position or applied signals. |

Vertical (both channels except as noted)

| | |
|----------------|--|
| VOLTS/DIV | Selects vertical deflection factor in 1-2-5 sequence (VARIABLE control must be in CAL position for indicated deflection factor). |
| VARIABLE | Provides continuously variable uncalibrated deflection factors between the calibrated settings of the VOLTS/DIV switch. |
| UNCAL | Light indicates that the VARIABLE control is not in the CAL position. |
| STEP ATTEN BAL | Screwdriver adjustment to balance Input Amplifier in the 5, 10 and 20 mV positions of the VOLTS/DIV switch. |
| POSITION | Controls vertical position of trace. In X-Y mode of operation, CH 1 control positions |

| | | | |
|----------------------------|---|---|--|
| | in the X-axis (horizontally) and CH 2 control positions in the Y-axis (vertically). | | |
| GAIN | Screwdriver adjustment to set gain of the Vertical Preamp. | INVERT (CH 2 only) | Inverts the Channel 2 display when pulled out. |
| Input Coupling (AC GND DC) | Selects method of coupling input signal to grid of Input Amplifier. AC: DC component of input signal is blocked. Low frequency limit (—3 dB point) is about 10 hertz. GND: Input circuit is grounded (does not ground applied signal). DC: All components of the input signal are passed to the Input Amplifier. | A and B Triggering (both where applicable) | |
| PROBE POWER | Power source for active probe systems. | LEVEL | Selects amplitude point on trigger signal at which sweep is triggered. |
| INPUT CH 1 OR X | Input connector for CH 1 deflection signals or X-axis deflection in the X-Y mode of operation. | HF STAB (A Triggering Only) | Decreases display jitter for trigger signals above about 40 megahertz. Has negligible effect at lower repetition rates. |
| INPUT CH 2 OR Y | Input connector for CH 2 deflection signals or Y-axis deflection in the X-Y mode of operation. | SLOPE | Selects slope of trigger signal which starts the sweep. +: Sweep can be triggered from positive-going portion of trigger signal. —: Sweep can be triggered from negative-going portion of trigger signal. |
| MODE | Selects vertical mode of operation. CH 1: The signal connected to the INPUT CH 1 connector is displayed. CH 2: The signal connected to the INPUT CH 2 connector is displayed. ALT: Dual-trace display of signals on both channels. Display switched at end of each sweep. CHOP: Dual-trace display of signals on both channels. Display switched between channels at a repetition rate of about one megahertz. ADD: Signals applied to the INPUT CH 1 and INPUT CH 2 connectors are algebraically added and the algebraic sum is displayed on the CRT. The INVERT switch in Channel 2 allows the display to be CH 1 + CH 2 or CH 1 — CH 2. | COUPLING | Determines method of coupling trigger signal to trigger circuit. AC: Rejects DC and attenuates signals below about 30 hertz. Accepts signals between about 30 hertz and 150 megahertz. LF REJ: Rejects DC and attenuates signals below about 50 kilohertz. Accepts signals between about 50 kilohertz and 150 megahertz. HF REJ: Accepts signals between about 30 hertz and 50 kilohertz; rejects DC and attenuates signals outside the above range. DC: Accepts all trigger signals from DC to 150 megahertz or greater. |
| TRIGGER | Selects source of internal triggering signal from vertical system. Also selects the source of the X signal for X-Y mode operation. NORM: Sweep circuits triggered from displayed channel(s). Channel 1 signal available at CH 1 OUT connector. CH 1 ONLY OR X-Y: Sweep circuits triggered only from signal applied to the INPUT CH 1 connector. No signal available at CH 1 OUT connector. CH 1 lights, located beside A and B SOURCE switches, indicate that the TRIGGER switch is in the CH 1 ONLY OR X-Y position. For X-Y mode operation, Channel 1 signal is connected to the Horizontal Amplifier. | SOURCE | Selects source of trigger signal. INT: Internal trigger signal obtained from Vertical Deflection System. When CH 1 light is on, trigger signal is obtained only from the Channel 1 input signal; when the light is off, the trigger signal is obtained from the displayed channel(s). Source of internal trigger signal is selected by the TRIGGER switch. LINE: Trigger signal obtained from a sample of the line voltage applied to this instrument. EXT: Trigger signal obtained from an external signal applied to the EXT TRIG INPUT connector. EXT ÷ 10: Attenuates external trigger signals 10 times. |
| | | CH 1 | Light indicates that the internal trigger signal is obtained only from the signal connected to the INPUT CH 1 connector (see TRIGGER switch). |
| | | EXT TRIG INPUT | Input connector for external trigger signal. |

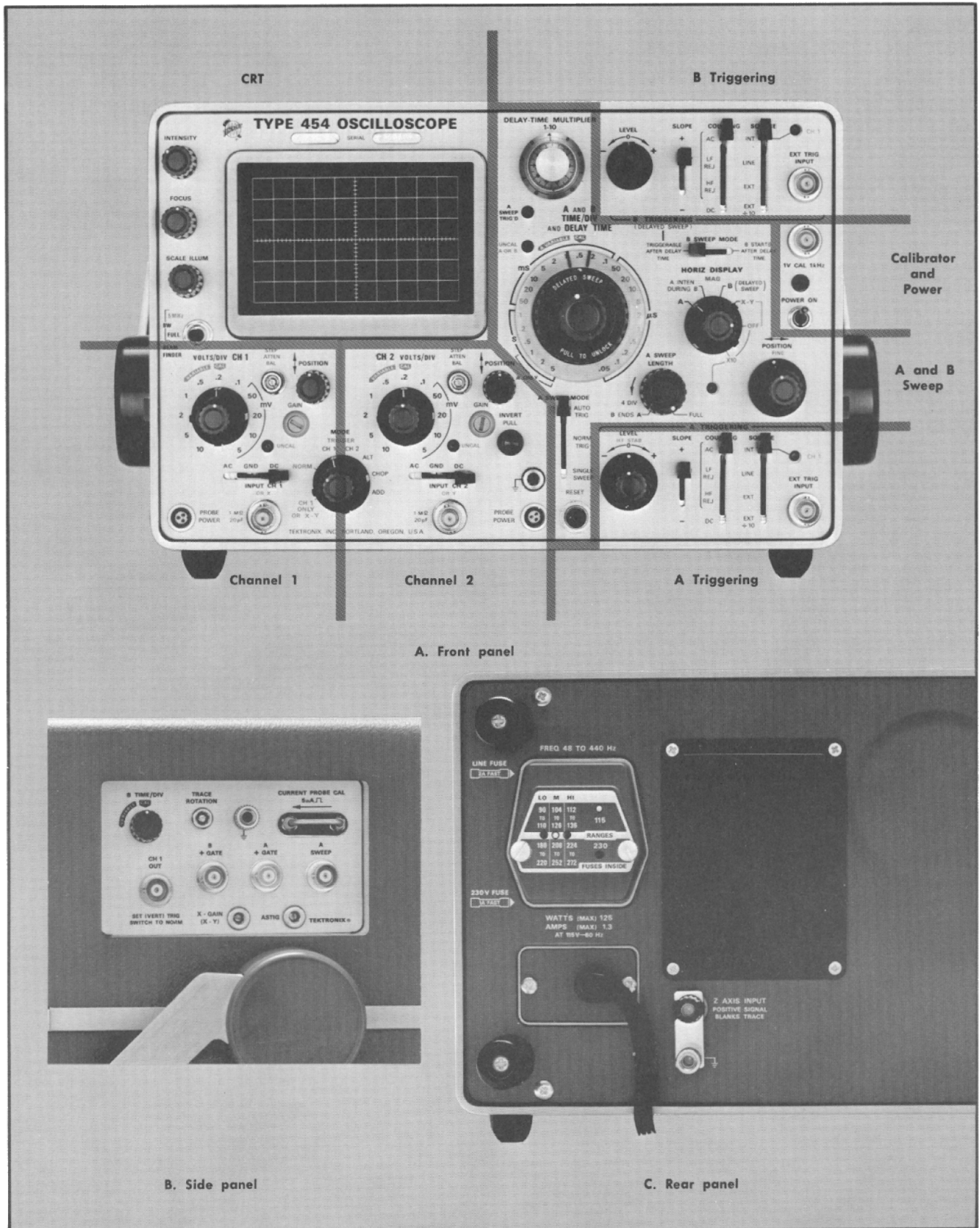

Fig. 2-4. Front-, side- and rear-panel controls and connectors.

A and B Sweep

DELAY-TIME MULTIPLIER Provides variable sweep delay between 0.10 and 10.10 times the delay time indicated by the A TIME/DIV switch.

A SWEEP TRIG'D Light indicates that A sweep is triggered and will produce a stable display with correct INTENSITY and POSITION control settings.

UNCAL A OR B Light indicates that either the A or B VARIABLE control is not in the CAL position.

A AND B TIME/DIV AND DELAY TIME A TIME/DIV switch (clear plastic inner flange) selects the sweep rate of the A sweep circuit for A sweep only operation and selects the basic delay time (to be multiplied by DELAY-TIME MULTIPLIER dial setting) for delayed sweep operation. B TIME/DIV (DELAYED SWEEP) switch selects sweep rate of the B sweep circuit for delayed sweep operation only. VARIABLE controls must be in the CAL positions for calibrated sweep rates.

A VARIABLE Provides continuously variable A sweep rate between the calibrated settings selected by the A TIME/DIV switch. A sweep rate is calibrated when control is set fully clockwise to CAL.

B SWEEP MODE Selects B sweep operation mode.

TRIGGERABLE AFTER DELAY TIME: B sweep circuit will not produce a sweep until a trigger pulse is received following the delay time selected by the DELAY TIME (A TIME/DIV) switch and the DELAY-TIME MULTIPLIER dial.

B STARTS AFTER DELAY TIME: B sweep circuit runs immediately following delay time selected by the DELAY TIME switch and DELAY-TIME MULTIPLIER dial.

HORIZ DISPLAY Selects horizontal mode of operation.

A: Horizontal deflection provided by A sweep. B sweep inoperative.

A INTEN DURING B: Sweep rate determined by A TIME/DIV switch. An intensified portion appears on the display during the B sweep time. This switch position provides a check of the duration and position of B sweep (delayed sweep) with respect to the delaying sweep (A).

B (DELAYED SWEEP): Sweep rate determined by B TIME/DIV switch with the delay time determined by the setting of the DELAY TIME (A TIME/DIV) switch and the DELAY-TIME MULTIPLIER dial. Sweep mode determined by B SWEEP MODE switch.

X-Y: Permits X-Y operation when the TRIGGER switch is set to CH 1 ONLY OR

X-Y. Signal applied to the INPUT CH 1 OR X connector provides the X-axis deflection and the signal applied to the INPUT CH 2 OR Y connector provides the Y-axis deflection.

MAG Increases sweep rate to ten times setting of the A or B TIME/DIV switch by horizontally expanding the center division of the display. Light indicates when magnifier is on (magnifier inoperative in X-Y mode).

A SWEEP MODE Determines the operating mode for A sweep.

AUTO TRIG: Sweep initiated by the applied trigger signal using the A Triggering controls when the trigger signal repetition rate is above about 20 hertz. For lower repetition rates or when there is no trigger signal, the sweep free runs at the sweep rate selected by the A TIME/DIV switch to produce a bright reference trace.

NORM TRIG: Sweep initiated by the applied trigger signal using the A Triggering controls. No trace when there is no trigger signal.

SINGLE SWEEP: After a sweep is displayed, further sweeps cannot be presented until the RESET button is pressed. Display is triggered as for NORM operation using the A Triggering controls.

RESET When the RESET button is pressed (SINGLE SWEEP mode), a single display will be presented (with correct triggering). After the sweep is completed, the RESET button must be pressed again before another sweep can be displayed.

A SWEEP LENGTH Adjusts length of A sweep. In the FULL position (clockwise detent), the sweep is about 11 divisions long. As this control is rotated counterclockwise, the length of A sweep is reduced until it is less than four divisions long just before the detent in the fully-counterclockwise position is reached. In the B ENDS A position (counterclockwise detent), the A sweep is reset at the end of the B sweep to provide the fastest possible sweep repetition rate for delayed sweep signals.

POSITION Controls horizontal position of trace.

FINE Provides more precise horizontal position adjustment.

1 V CAL 1 kHz Calibrator output connector.

POWER ON Light: Indicates that POWER switch is on and the instrument is connected to a line-voltage source.

Switch: Controls power to the instrument.

Operating Instructions—Type 454/R454

Side Panel

| | |
|---------------------|---|
| B TIME/DIV VARIABLE | Provides continuously variable B sweep rate between the calibrated settings selected by the B TIME/DIV switch. B sweep rate is calibrated when control is set fully clockwise to CAL. |
| TRACE ROTATION | Screwdriver adjustment to align trace with horizontal graticule lines. |
| CURRENT PROBE CAL | Current loop providing five-milliampere square-wave current from calibrator circuit. |
| CH 1 OUT | Output connector providing a sample of the signal applied to the INPUT CH 1 connector when the TRIGGER switch is in the NORM position. |
| B + GATE | Output connector providing a rectangular pulse coincident with B sweep. |
| A + GATE | Output connector providing a rectangular pulse coincident with A Sweep. |
| A SWEEP | Output connector providing a sample of the sawtooth signal produced by the A Sweep Generator. |
| X-GAIN (X-Y) | Screwdriver adjustment to calibrate X-axis deflection in the X-Y mode. |
| ASTIG | Screwdriver adjustment used in conjunction with the FOCUS control to obtain a well-defined display. Does not require readjustment in normal use. |

Rear Panel

| | |
|-----------------------|---|
| Z AXIS INPUT | Input connector for intensity modulation of the CRT display. |
| Line Voltage Selector | Switching assembly to select the nominal operating voltage and the line voltage range. The assembly also includes the line fuses. Voltage Selector: Selects nominal operating voltage range (115 V or 230 V). Range Selector: Selects line voltage range (low, medium, high). |

FIRST-TIME OPERATION

The following steps will demonstrate the use of the controls and connectors of the Type 454. It is recommended that this procedure be followed completely for first-time familiarization with this instrument.

Setup Information

1. Set the controls as follows:

CRT Controls

| | |
|----------------|------------------|
| INTENSITY | Counterclockwise |
| FOCUS | Midrange |
| SCALE ILLUM | Counterclockwise |
| BW-BEAM FINDER | FULL- |

Vertical Controls (both channels if applicable)

| | |
|----------------|-----------|
| VOLTS/DIV | .2 |
| VARIABLE | CAL |
| POSITION | Midrange |
| Input Coupling | DC |
| MODE | CH 1 |
| TRIGGER | NORM |
| INVERT | Pushed in |

Triggering Controls (both A and B if applicable). All lever switches up.

| | |
|----------|---------------|
| LEVEL | Clockwise (+) |
| SLOPE | + |
| COUPLING | AC |
| SOURCE | INT |

Sweep Controls

| | |
|-----------------------|-------------------------------|
| DELAY-TIME MULTIPLIER | 0.10 (fully counterclockwise) |
| A and B TIME/DIV | .5 ms |
| A VARIABLE | CAL (fully clockwise) |
| A SWEEP MODE | AUTO TRIG |
| B SWEEP MODE | B STARTS AFTER DELAY TIME |
| HORIZ DISPLAY | A |
| MAG | OFF |
| POSITION | Midrange |
| A SWEEP LENGTH | FULL (fully clockwise) |
| POWER | OFF |

Side-Panel Controls

| | |
|---------------------|-----------------------|
| B TIME/DIV VARIABLE | CAL (fully clockwise) |
|---------------------|-----------------------|

2. Connect the Type 454 to a power source that meets the voltage and frequency requirements of the instrument. If the available line voltage is outside the limits of the Line Voltage Selector switch position (on rear panel), see Operating Voltage in this section.

3. Set the POWER switch to ON. Allow several minutes warm up so the instrument reaches a normal operating temperature before proceeding.

CRT Controls

4. Advance the INTENSITY control until the trace is at the desired viewing level (near midrange).

5. Connect the 1 V CAL 1 kHz connector to the INPUT CH 1 connector with a BNC cable.

6. Turn the A LEVEL control toward 0 until the display becomes stable. Note that the A SWEEP TRIG'D light is on when the display is stable.

7. Adjust the FOCUS control for a sharp, well-defined display over the entire trace length. (If focused display cannot be obtained, see Astigmatism Adjustment in this section.)

8. Disconnect the input signal and move the trace with the CH 1 POSITION control so it coincides with the center horizontal line of the graticule.

9. If the trace is not parallel with the center horizontal line, see Trace Alignment Adjustment in this section.

10. Rotate the SCALE ILLUM control throughout its range and notice that the graticule lines are illuminated as the control is turned clockwise (most obvious with mesh or smoke-gray filter installed). Set control so graticule lines are illuminated as desired.

Vertical Controls

11. Change the CH 1 VOLTS/DIV switch from 20 mV to 5 mV. If the vertical position of the trace shifts, see Step Attenuator Balance in this section.

12. Set the CH 1 VOLTS/DIV switch to .2 and the CH 1 Input Coupling switch to AC.

13. Connect the 1 V CAL 1 kHz connector to both the INPUT CH 1 and CH 2 connectors with two BNC cables and a BNC T connector.

NOTE

If the BNC cables and BNC T connector are not available, make the following changes in the procedure. Place the BNC jack post (supplied accessory) on the 1 V CAL 1 kHz connector and connect the two 10× probes (supplied accessories) to the INPUT CH 1 and CH 2 connectors. Connect the probe tips to the BNC jack post. Set the CH 1 and CH 2 VOLTS/DIV switches to deflection factors that are 1/10th of those given.

14. Turn the CH 1 POSITION control to center the display. The display is a square wave, five divisions in amplitude with about five cycles displayed on the screen. If the display is not five divisions in amplitude, see Vertical Gain Adjustment in this section.

15. Set the CH 1 Input Coupling switch to GND and position the trace to the center horizontal line.

16. Set the CH 1 Input Coupling switch to DC. Note that the baseline of the waveform remains at the center horizontal line (ground reference).

17. Set the CH 1 Input Coupling switch to AC. Note that the waveform is centered about the center horizontal line.

18. Turn the CH 1 VARIABLE control throughout its range. Note that the UNCAL light comes on when the VARIABLE control is moved from the CAL position (fully clockwise). The deflection should be reduced to about two divisions in the fully counterclockwise position. Return the CH 1 VARIABLE control to CAL.

19. Set the MODE switch to CH 2.

20. Set the CH 2 Input Coupling switch to GND and check the Channel 2 step attenuator balance as described in step 11. Return the CH 2 Input Coupling switch to DC.

21. Turn the CH 2 POSITION control to center the display. The display will be similar to the previous display for Channel 1. Check the Channel 2 gain as described in step 14. The CH 2 Input Coupling switch and VARIABLE control operate as described in steps 15 through 18.

22. Set both VOLTS/DIV switches to .5.

23. Set the MODE switch to ALT and position the Channel 1 waveform to the top of the graticule area and the Channel 2 waveform to the bottom of the graticule area. Turn the A TIME/DIV switch throughout its range. Note that the display alternates between channels at all sweep rates.

24. Set the MODE switch to CHOP and the A TIME/DIV switch to 2 μs. Note the switching between channels as shown by the segmented trace. Set the TRIGGER switch to CH 1 ONLY; the trace should appear more solid since it is no longer triggered on the between-channel switching transients. Turn the A TIME/DIV switch throughout its range. A dual-trace display is presented at all sweep rates, but unlike ALT, both channels are displayed on each sweep on a time-sharing basis. Return the A TIME/DIV switch to .5 ms.

25. Set the MODE switch to ADD. The display should be four divisions in amplitude. Note that either POSITION control moves the display.

26. Pull the INVERT switch to invert the Channel 2 signal. The display is a straight line (if the Channel 1 and 2 gain is set correctly) indicating that the algebraic sum of the two signals is zero. Set either VOLTS/DIV switch to .2. The square-wave display indicates that the algebraic sum of the two signals is no longer zero. Return the MODE switch to CH 1 and both VOLTS/DIV switches to .2. Push in the INVERT switch.

Triggering

27. Rotate the A LEVEL control throughout its range. The display free runs at the extremes of rotation. Note that the A SWEEP TRIG'D light is on only when the display is triggered.

28. Set the A SWEEP MODE switch to NORM TRIG. Again rotate the A LEVEL control throughout its range. A display is presented only when correctly triggered. The A SWEEP TRIG'D light operates as in AUTO TRIG. Return the A SWEEP MODE switch to AUTO TRIG.

29. Set the A SLOPE switch to —. The trace starts on the negative part of the square wave. Return the switch to +; the trace starts with the positive part of the square wave.

30. Set the A COUPLING switch to DC. Turn the CH 1 POSITION control until the display becomes unstable (only part of square wave visible). Return the A COUPLING switch to AC; the display is again stable. Since changing trace position changes DC level, this shows how changes in the DC level affect DC trigger coupling. Return the display to the center of the screen.

31. Set the MODE switch to CH 2; the display should be stable. Remove the signal connected to Channel 1; the display free runs. Set the TRIGGER switch to NORM; the display is again stable. Note that the CH 1 lights in A and B Triggering go out when the TRIGGER switch is changed to NORM.

32. Connect the Calibrator signal to both the INPUT CH 2 connector and the A EXT TRIG INPUT connector. Set the A SOURCE switch to EXT. Operation of the LEVEL, SLOPE and COUPLING controls for external triggering are the same as described in steps 27 through 30.

Operating Instructions—Type 454/R454

33. Set the A SOURCE switch to EXT $\div 10$. Operation is the same as for EXT. Note that the A LEVEL control has less range in this position, indicating trigger signal attenuation. Return the A SOURCE switch to INT.

34. Operation of the B Triggering controls is similar to A Triggering.

Normal and Magnified Sweep

35. Set the A TIME/DIV switch to 5 ms and the MAG switch to $\times 10$. The display should be similar to that obtained with the A TIME/DIV switch set to .5 ms and the MAG switch to OFF.

36. Turn the Horizontal POSITION control throughout its range; the display should be positionable across the complete display area. Now turn the FINE control. The display moves a smaller amount and allows more precise positioning. Return the A TIME/DIV switch to .5 ms, the MAG switch to OFF and return the start of the trace to the left graticule line.

37. Turn the A VARIABLE control throughout its range. Note that the UNCAL A OR B light comes on when the A VARIABLE control is moved from the CAL position (fully clockwise). The sweep rate is slower by about 2.5 times in the fully counterclockwise position as indicated by more cycles displayed on the CRT. Return the A VARIABLE control to CAL.

Delayed Sweep

38. Pull the DELAYED SWEEP knob out and turn it to 50 μs (DELAY TIME remains at .5 ms). Set the HORIZ DISPLAY switch to A INTEN DURING B. An intensified portion, about one division in length, should be shown at the start of the trace. Rotate the DELAY-TIME MULTIPLIER dial throughout its range; the intensified portion should move along the display.

39. Set the B SWEEP MODE switch to TRIGGERABLE AFTER DELAY TIME and set the B LEVEL control to midrange. Again rotate the DELAY-TIME MULTIPLIER dial throughout its range and note that the intensified portion appears to jump between positive slopes of the display. Set the B SLOPE switch to $-$; the intensified portion begins on the negative slope. Rotate the B LEVEL control; the intensified portion of the display disappears when the B LEVEL control is out of the triggerable range. Return the B LEVEL control to 0.

40. Set the HORIZ DISPLAY switch to B (DELAYED SWEEP). Rotate the DELAY-TIME MULTIPLIER dial throughout its range; about one-half cycle of the waveform should be displayed on the screen (leading edge visible only at high INTENSITY control setting). The display remains stable on the screen, indicating that the B sweep is triggered.

41. Set the B SWEEP MODE switch to B STARTS AFTER DELAY TIME. Rotate the DELAY-TIME MULTIPLIER dial throughout its range; the display moves continuously across the screen as the control is rotated.

42. Rotate the DELAY-TIME MULTIPLIER dial fully counterclockwise and set the HORIZ DISPLAY switch to A INTEN DURING B. Rotate the A SWEEP LENGTH control counterclockwise; the length of the display decreases. Set the control to the B ENDS A position; now the display ends after

the intensified portion. Rotate the DELAY-TIME MULTIPLIER dial and note that the sweep length increases as the display moves across the screen. Return the A SWEEP LENGTH control to FULL and the HORIZ DISPLAY switch to A.

Single Sweep

43. Set the A SWEEP MODE switch to SINGLE SWEEP. Remove the Calibrator signal from the INPUT CH 2 connector. Press the RESET button; the RESET light should come on and remain on. Again apply the signal to the INPUT CH 2 connector; a single trace should be presented and the RESET light should go out. Return the A SWEEP MODE switch to AUTO TRIG.

X-Y

44. Connect the Calibrator signal to the INPUT CH 1 and CH 2 connectors with two BNC cables and a BNC T connector. Set the HORIZ DISPLAY switch to X-Y and the TRIGGER switch to CH 1 ONLY OR X-Y.

45. Increase the INTENSITY control setting until two dots are displayed diagonally. The display can be positioned horizontally with the CH 1 POSITION control and vertically with the CH 2 POSITION control. The dots should be five divisions apart vertically and horizontally (if horizontal deflection is incorrect see X-Y Operation in this section).

46. Change the CH 1 VOLTS/DIV switch to .5. The display is reduced to two divisions horizontally. Now set the CH 2 VOLTS/DIV switch to .5. The display is reduced to two divisions vertically.

Beam Finder

47. Set the CH 1 and CH 2 VOLTS/DIV switches to 10 mV. The display is not visible since it exceeds the scan area of the CRT.

48. Press the BW-BEAM FINDER switch down. Note that the display is returned to the display area. While holding the BW-BEAM FINDER switch down, increase the vertical and horizontal deflection factor until the display is reduced to about three divisions vertically and horizontally. Adjust the CH 1 and CH 2 POSITION controls to center the display about the center lines of the graticule. Release the BW-BEAM FINDER switch and note that the display remains within the viewing area. Disconnect the applied signal.

49. Reduce the INTENSITY control setting to normal, set the TRIGGER switch to NORM and set the HORIZ DISPLAY switch to A.

Bandwidth Limiter

50. Set the CH 2 VOLTS/DIV switch to 5 mV. Connect an unshielded lead about four feet long to the INPUT CH 2 connector. Set the A TIME/DIV switch to .1 μs and note the high-frequency noise in the display (this demonstration is most effective in localities with strong radiated interference above five megahertz such as TV broadcast radiation; if little interference is present, a 50 megahertz sine-wave signal applied to the INPUT CH 2 connector will produce a similar result).

51. Set the BW-BEAM FINDER switch to 5 MHz (up). Note that the high-frequency noise is eliminated from the display. Return the BW-BEAM FINDER switch to FULL.

Z-Axis Input

52. If an external signal is available (five volts peak-to-peak minimum) the function of the Z AXIS INPUT circuit can be demonstrated. Connect the external signal to both the INPUT CH 2 connector and the Z AXIS INPUT binding posts. Set the TIME/DIV switch to display about five cycles of the waveform. The positive peaks of the waveform should be blanked and the negative peaks intensified, indicating intensity modulation.

53. This completes the basic operating procedure for the Type 454. Instrument operations not explained here, or operations which need further explanation are discussed under General Operating Information.

CONTROL SETUP CHART

Fig. 2-5 shows the front, side and rear panels of the Type 454. This chart can be reproduced and used as a test-setup record for special measurements, applications or procedures, or it may be used as a training aid for familiarization with this instrument.

GENERAL OPERATING INFORMATION

Intensity Control

The setting of the INTENSITY control may affect the correct focus of the display. Slight readjustment of the FOCUS control may be necessary when the intensity level is changed.

To protect the CRT phosphor, do not turn the INTENSITY control higher than necessary to provide a satisfactory display. The light filters reduce the observed light output from the CRT. When using these filters, avoid advancing the INTENSITY control to a setting that may burn the phosphor. When the highest intensity display is desired, remove the filters and use the clear faceplate protector. Also, be careful that the INTENSITY control is not set too high when changing the TIME/DIV switch from a fast to a slow sweep rate, or when changing the HORIZ DISPLAY switch from X-Y operation to the normal sweep mode. The Z Axis Amplifier incorporates a protection circuit which automatically reduces the display intensity to a lower level at the slower sweep rates. This reduces the danger of burning the CRT phosphor at these slower sweep rates.

Astigmatism Adjustment

If a well-defined trace cannot be obtained with the FOCUS control, adjust the ASTIG adjustment (side panel) as follows.

NOTE

To check for proper setting of the ASTIG adjustment, slowly turn the FOCUS control through the optimum setting. If the ASTIG adjustment is correctly set, the vertical and horizontal portions of

the trace will come into sharpest focus at the same position of the FOCUS control. The setting of the ASTIG adjustment should be correct for any display. However, it may be necessary to reset the FOCUS control slightly when the INTENSITY control is changed.

1. Connect the 1 V CAL 1 kHz connector to either channel and set the VOLTS/DIV switch of that channel to present a two-division display. Set the MODE switch to display the channel selected.
2. Set the TIME/DIV switch to .2 ms.
3. With the FOCUS control and ASTIG adjustment set to midrange, adjust the INTENSITY control so the rising portion of the display can be seen.
4. Set the ASTIG adjustment so the horizontal and vertical portions of the display are equally focused, but not necessarily well focused.
5. Set the FOCUS control so the vertical portion of the trace is as thin as possible.
6. Repeat parts 4 and 5 for the best overall focus. Make the final check at normal intensity.

Trace Alignment Adjustment

If a free-running trace is not parallel to the horizontal graticule lines, set the TRACE ROTATION adjustment (side-panel) as follows. Position the trace to the center horizontal line. Adjust the TRACE ROTATION adjustment so the trace is parallel with the horizontal graticule lines.

Light Filter

The mesh filter provided with the Type 454 provides shielding against radiated EMI (electro-magnetic interference) from the face of the CRT. It also serves as a light filter to make the trace more visible under high ambient light conditions. To remove the filter, press down at the bottom of the frame and pull the top of the filter away from the CRT faceplate (see Fig. 2-6).

The tinted light filter minimizes light reflections from the face of the CRT to improve contrast when viewing the display under high ambient light conditions. A clear plastic faceplate protector is also provided with this instrument for use when neither the mesh nor the tinted filter is used. The clear faceplate protector provides the best display for waveform photographs. It is also preferable for viewing high writing rate displays.

A filter or the faceplate protector should be used at all times to protect the CRT faceplate from scratches. The faceplate protector and the tinted light filter mount in the same holder. To remove the light filter or faceplate protector from the holder, press it out to the rear. They can be replaced by snapping them back into the holder.

Beam Finder

The BW-BEAM FINDER switch provides a means of locating a display which overscans the viewing area either ver-

TYPE 454 TEST SETUP CHART

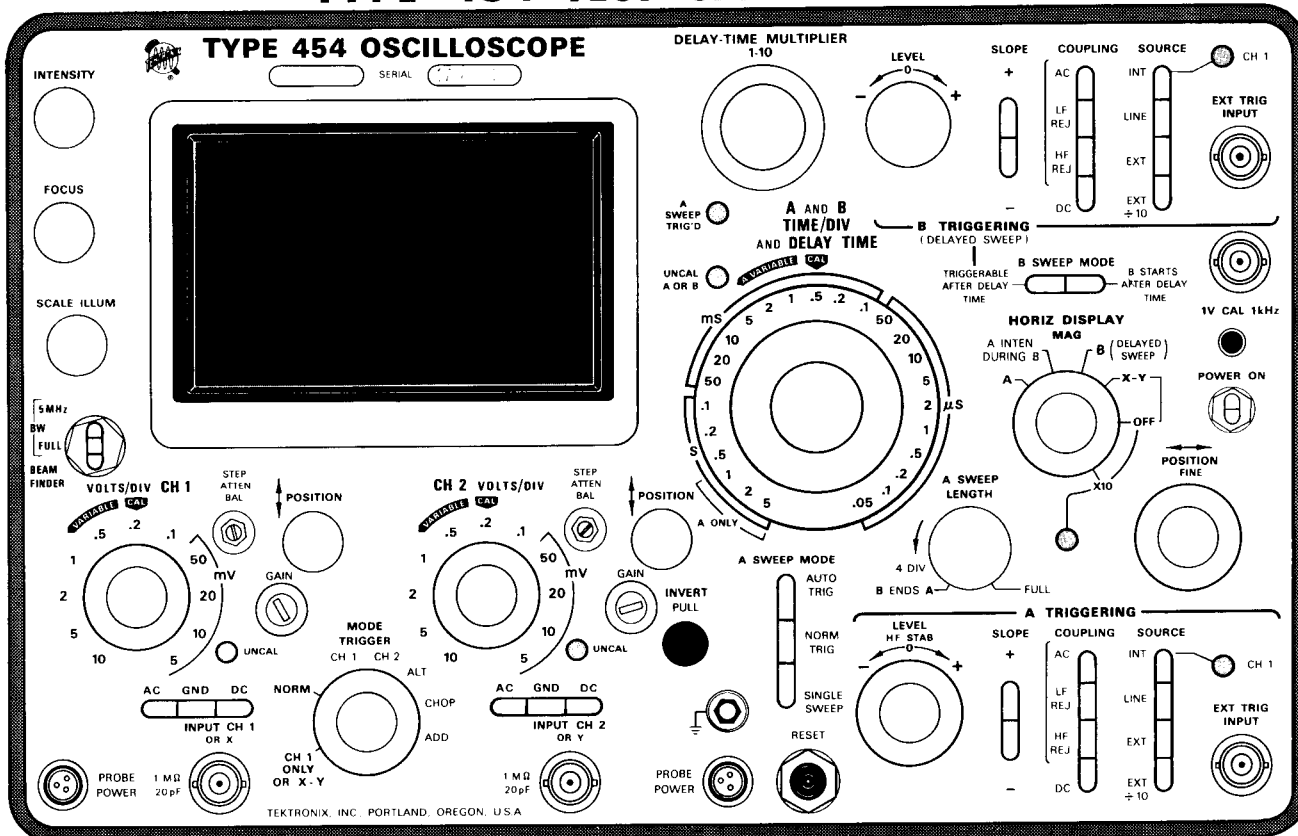

A. Front panel

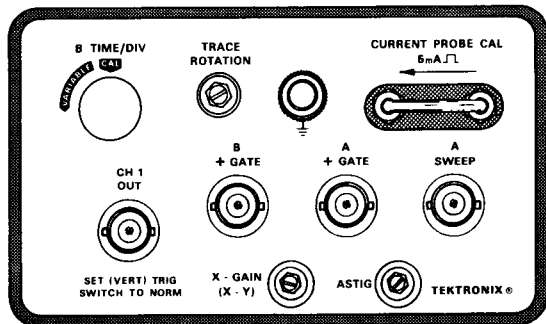

B. Side panel

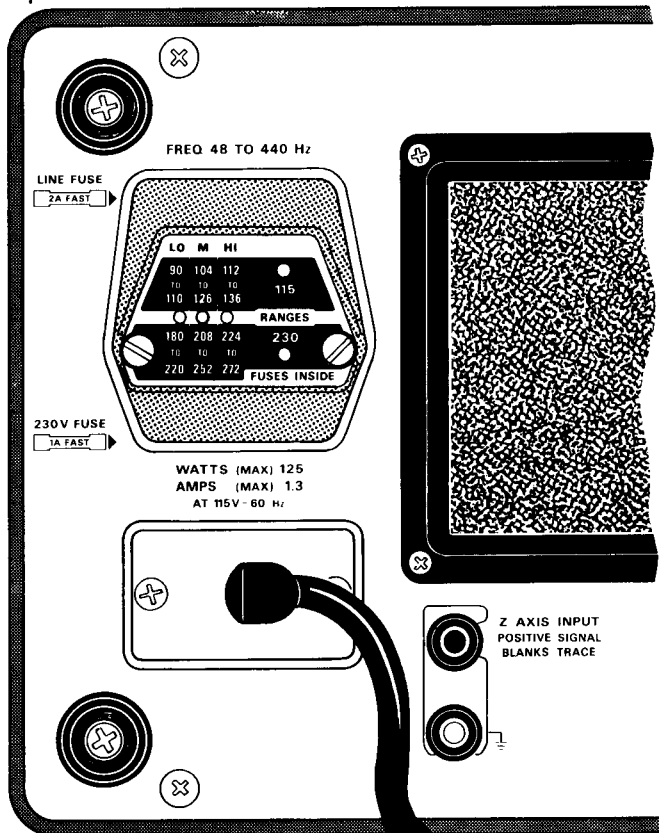

C. Rear panel

Fig. 2-5.

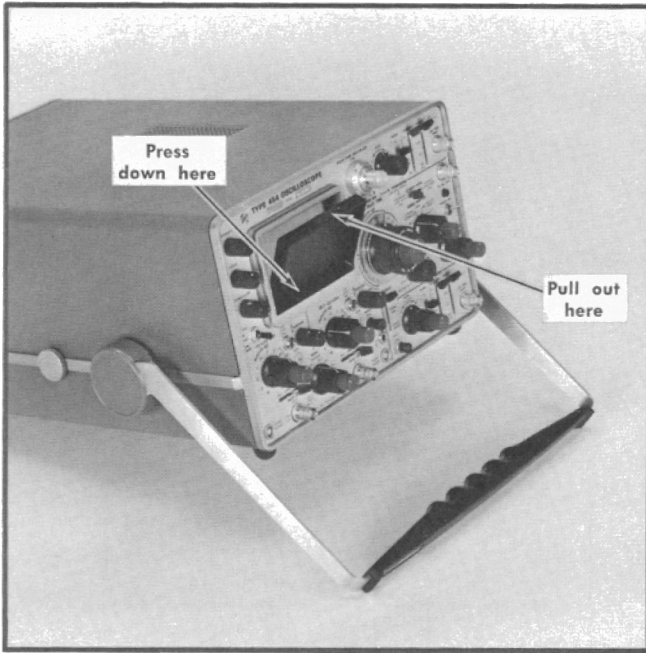

Fig. 2-6. Removing the filter or faceplate protector.

tically or horizontally. When the BW-BEAM FINDER switch is pressed down, the display is compressed within the graticule area. To locate and reposition an overscanned display, use the following procedure.

1. Press the BW-BEAM FINDER switch down.
2. While the BW-BEAM FINDER switch is held down, increase the vertical and horizontal deflection factors until the vertical deflection is reduced to about three divisions and the horizontal deflection is reduced to about four divisions (the horizontal deflection needs to be reduced only when in the X-Y mode of operation).
3. Adjust the vertical and horizontal position controls to center the display about the vertical and horizontal center lines.
4. Release the BW-BEAM FINDER switch; the display should remain within the viewing area.

Graticule

The graticule of the Type 454 is internally marked on the faceplate of the CRT to provide accurate, no-parallax measurements. The graticule is marked with six vertical and 10 horizontal divisions. Each division is 0.8 centimeter square. In addition, each major division is divided into five minor divisions at the center vertical and horizontal lines. The vertical gain and horizontal timing are calibrated to the graticule so accurate measurements can be made from the CRT. The illumination of the graticule lines can be varied with the SCALE ILLUM control.

Fig. 2-7 shows the graticule of the Type 454 and defines the various measurement lines. The terminology defined here will be used in all discussions involving graticule measurements.

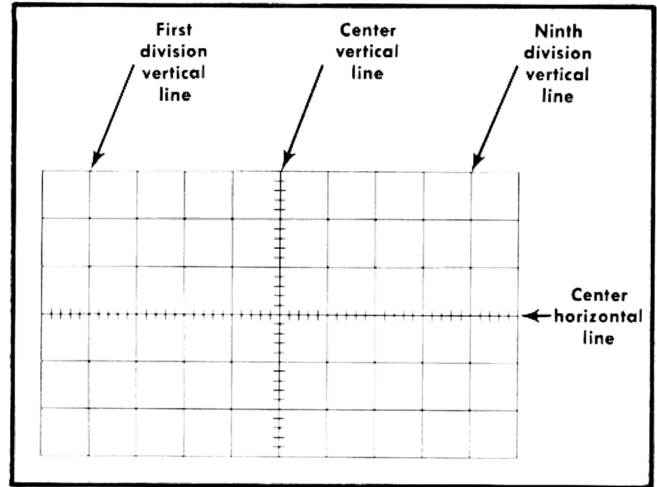

Fig. 2-7. Definition of measurement lines on Type 454 graticule.

Vertical Channel Selection

Either of the input channels can be used for single-trace displays. Apply the signal to the desired INPUT connector and set the MODE switch to display the channel used. However, since CH 1 ONLY triggering is provided only in Channel 1 and the INVERT feature is provided only in Channel 2, the correct channel must be selected to take advantage of these features. For dual-trace displays, connect the signals to both INPUT connectors and set the MODE switch to one of the dual-trace positions.

Vertical Gain Adjustment

To check the gain of either channel, set the VOLTS/DIV switch to .2 and connect the 1 V CAL 1 kHz connector to the INPUT connector of the channel used. The vertical deflection should be exactly five divisions. If not, adjust the front-panel GAIN adjustment for exactly five divisions of deflection.

NOTE

If the gain of the two channels must be closely matched (such as for ADD mode operation), the adjustment procedure given in the Calibration section should be used.

The best measurement accuracy when using probes is provided if the GAIN adjustment is made with the probes installed (set the VOLTS/DIV switch to 20 mV). Also, to provide the most accurate measurements, calibrate the vertical gain of the Type 454 at the temperature at which the measurement is to be made.

Step Attenuator Balance

To check the step attenuator balance of either channel, set the Input Coupling switch to GND and set the A SWEEP MODE switch to AUTO TRIG to provide a free-running trace. Change the VOLTS/DIV switch from 20 mV to 5 mV.

Operating Instructions—Type 454/R454

If the trace moves vertically, adjust the front-panel STEP ATTEN BAL adjustment as follows (allow at least 10 minutes warm up before performing this adjustment).

1. With the Input Coupling switch set to GND and the VOLTS/DIV switch set to 20 mV, move the trace to the center horizontal line of the graticule with the vertical POSITION control.

2. Set the VOLTS/DIV switch to 5 mV and adjust the STEP ATTEN BAL adjustment to return the trace to the center horizontal line.

3. Recheck step attenuator balance and repeat adjustment until no trace shift occurs as the VOLTS/DIV switch is changed from 20 mV to 5 mV.

Signal Connections

In general, probes offer the most convenient means of connecting a signal to the input of the Type 454. The Tektronix probes are shielded to prevent pickup of electrostatic interference. A 10× attenuator probe offers a high input impedance and allows the circuit under test to perform very close to normal operating conditions. However, a 10× probe also attenuates the input signal 10 times. The Tektronix P6045 Field Effect Transistor probe offers the same high-input impedance as the 10× probes. However, it is particularly useful since it provides wide-band operation while presenting no attenuation (1× gain) and a low input capacitance. To obtain maximum bandwidth when using the probes, observe the grounding considerations given in the probe manuals. The probe-to-connector adapters and the bayonet-ground tip provide the best frequency response. Remember that a ground strap only a few inches in length can produce several percent of ringing when operating at the higher frequency limit of this system (see Fig. 2-8). Fig. 2-9 graphically illustrates the usable frequency range (at upper -3 dB point) of various Tektronix probes when used with the Type 454 (for deflection factors from 20 mV to 10 V). Only a few of the available probes are shown in this chart. See your Tektronix, Inc. catalog for characteristics and compatibility of other probes for this system.

In high-frequency applications requiring maximum overall bandwidth, use coaxial cables terminated at both ends in their characteristic impedance. To maintain the high-frequency characteristics of the applied signal, use high-quality, low-loss cable. Resistive coaxial attenuators can be used to minimize reflections due to the 20 pF input capacitance if the applied signal has sufficient amplitude.

High-level, low-frequency signals can be connected directly to the Type 454 INPUT connectors with short unshielded leads. This coupling method works best for signals below about one kilohertz and deflection factors above one volt/division. When this method is used, establish a common ground between the Type 454 and the equipment under test (common ground provided by line cords is usually inadequate). Attempt to position the leads away from any source of interference to avoid errors in the display. If interference is excessive with unshielded leads, use a coaxial cable or a probe.

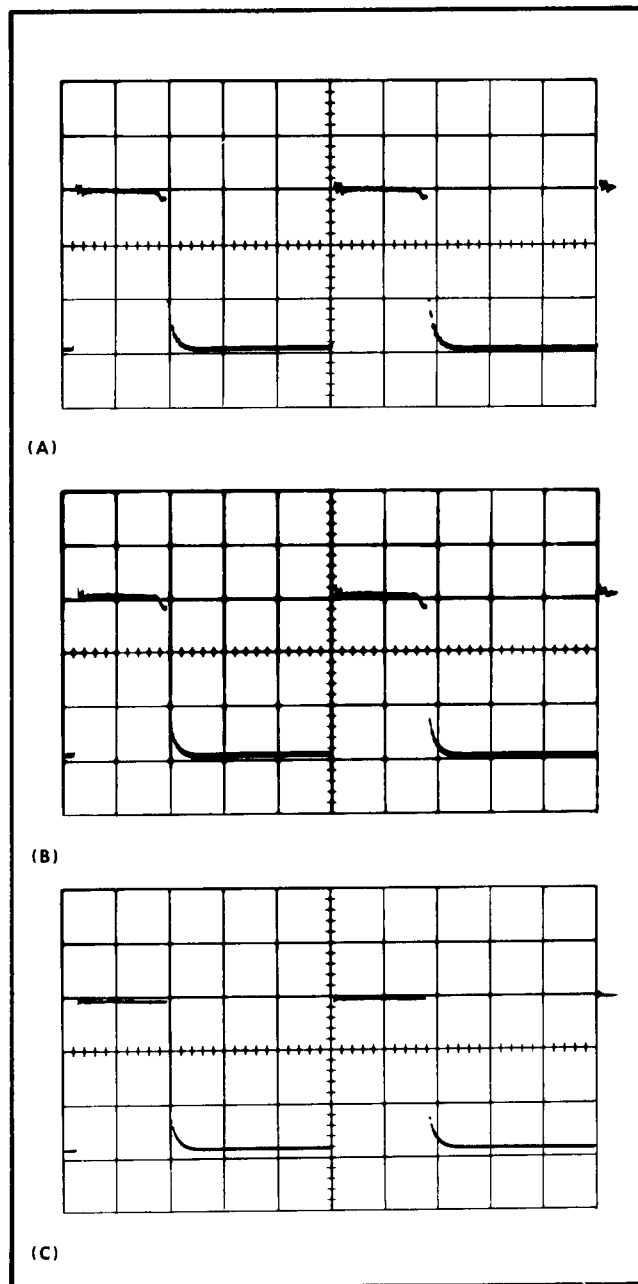

Fig. 2-8. Waveform distortion produced with incorrect probe ground. (A) Five-inch ground lead, (B) three-inch ground lead, (C) bayonet ground adapter.

Loading Effect of the Type 454

As nearly as possible, simulate actual operating conditions in the equipment under test. Otherwise, the equipment under test may not produce a normal signal. The 10× attenuator and field effect transistor probes mentioned previously offer the least circuit loading. See the probe instruction manual for loading characteristics of the probes.

When the signal is coupled directly to the input of the Type 454, the input impedance is about one megohm paralleled by about 20 pF. When the signal is coupled to the input through a coaxial cable, the effective input capaci-

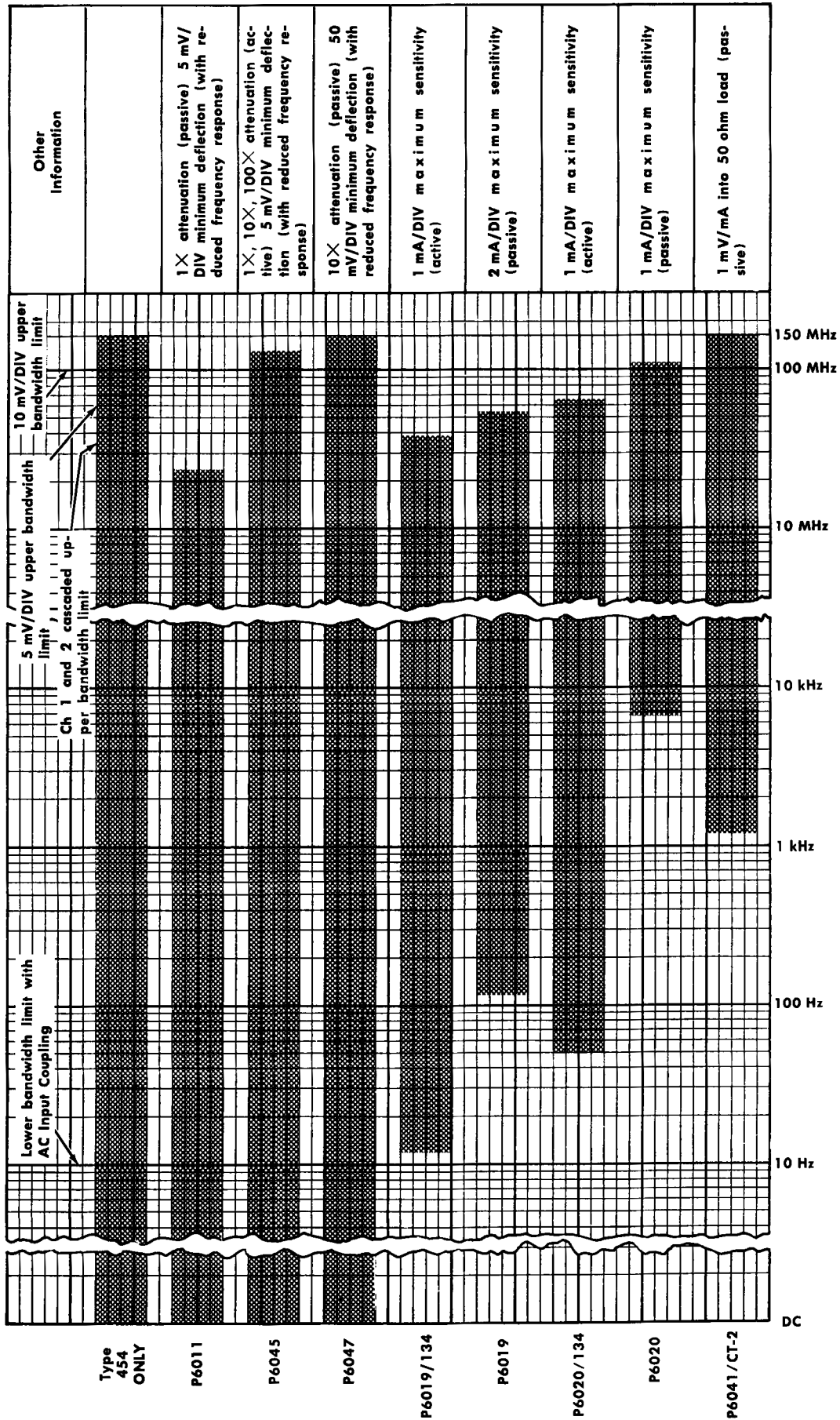

Fig. 2-9. Frequency range of probe coupling (approximate — 3 dB points) when driven by 25-ohm source.

Operating Instructions—Type 454/R454

tance depends upon the type and length of cable used and the frequency of the signal.

Input Coupling

The Channel 1 and 2 Input Coupling switches allow a choice of input coupling. The type of display desired determines the mode of input coupling used.

The DC position can be used for most applications. However, if the DC component of the signal is much larger than the AC component, the AC position will probably provide a better display. DC coupling should be used to display AC signals below about 10 hertz as they will be attenuated in the AC position.

In the AC position, the DC component of the signal is blocked by a capacitor in the input circuit. The low-frequency response in the AC position is about 10 hertz (−3 dB point). Therefore, some low-frequency distortion can be expected near this frequency limit. Distortion will also appear in square waves which have low-frequency components.

The GND position provides a ground reference at the input of the Type 454. The signal applied to the INPUT connector is internally disconnected but not grounded. The input circuit is held at ground potential, eliminating the need to externally ground the input to establish a DC ground reference.

The GND position can also be used to pre-charge the coupling capacitor to the average voltage level of the signal applied to the INPUT connector. This allows measurement of only the AC component of signals having both AC and DC components. The pre-charging network incorporated in this unit allows the input-coupling capacitor to charge to the DC source voltage level when the Input Coupling switch is set to GND. The procedure for using this feature is as follows:

1. Before connecting the signal containing a DC component to the Type 454 INPUT connector, set the Input Coupling switch to GND. Then connect the signal to the INPUT connector.
2. Wait about one second for the coupling capacitor to charge.
3. Set the Input Coupling switch to AC. The trace (display) will remain on the screen and the AC component of the signal can be measured in the normal manner.

Deflection Factor

The amount of vertical deflection produced by a signal is determined by the signal amplitude, the attenuation factor of the probe (if used), the setting of the VOLTS/DIV switch and the setting of the VARIABLE VOLTS/DIV control. The calibrated deflection factors indicated by the VOLTS/DIV switches apply only when the VARIABLE control is set to the CAL position.

The VARIABLE VOLTS/DIV control provides variable (un-calibrated) vertical deflection between the calibrated settings of the VOLTS/DIV switch. The VARIABLE control ex-

tends the maximum vertical deflection factor of the Type 454 to at least 25 volts/division (10 volts position).

Probe Power Connectors

The two PROBE POWER connectors on the front panel of this instrument provide operating power for active probe systems such as the Tektronix P6045 Field Effect Transistor Probe. It is not recommended that this connector be used as a power source for applications other than the compatible probes. However, if used for other applications, limit the maximum current from both connectors to 50 milliamperes from the +12-volt terminal and 100 milliamperes from the −12-volt terminal. Maintain a constant load on the supplies to avoid adding transients to the system.

Dual-Trace Operation

Alternate Mode. The ALT position of the MODE switch produces a display which alternates between Channel 1 and 2 with each sweep of the CRT. Although the ALT mode can be used at all sweep rates, the CHOP mode provides a more satisfactory display at sweep rates below about 20 microseconds/division. At these slower sweep rates, alternate mode switching becomes visually perceptible.

Proper internal triggering in the ALT mode can be obtained in either the NORM or CH 1 ONLY positions of the TRIGGER switch. When in the NORM position, the sweep is triggered from the signal on each channel. This provides a stable display of two unrelated signals, but does not indicate the time relationship between the signals. In the CH 1 ONLY position, the two signals are displayed showing true time relationship. If the signals are not time related, the Channel 2 waveform will be unstable in the CH 1 ONLY position.

Chopped Mode. The CHOP position of the MODE switch produces a display which is electronically switched between channels. In general, the CHOP mode provides the best display at sweep rates slower than about 20 microseconds/division or whenever dual-trace, single-shot phenomena are to be displayed. At faster sweep rates the chopped switching becomes apparent and may interfere with the display.

Proper internal triggering for the CHOP mode is provided only when the TRIGGER switch is set to CH 1 ONLY. If the NORM position is used, the sweep circuits are triggered from the between-channel switching signal and both waveforms will be unstable. External triggering from a signal which is time-related to either signal provides the same result as CH 1 ONLY triggering.

Two signals which are time-related can be displayed in the chopped mode showing true time relationship. However, if the signals are not time-related, the Channel 2 display will appear unstable.

Two single-shot, transient, or random signals which occur within the time interval determined by the TIME/DIV switch (10 times sweep rate) can be compared using the CHOP mode. To trigger the sweep correctly, the Channel 1 signal must precede the Channel 2 signal. Since the signals show true time relationship, time-difference measurements can be made.

Bandwidth Limiter

The BW-BEAM FINDER switch provides a method of reducing interference from unwanted high-frequency signals when viewing low-frequency signals. In the FULL position, the full bandwidth capabilities of the Vertical Deflection system are available. When set to the 5 MHz position (up), the upper -3 dB bandwidth point of the Vertical Deflection system is limited to about six megahertz. Then unwanted high-frequency signals (such as television broadcast radiation interference) are reduced in the displayed waveform. Fig. 2-10 illustrates the use of this feature. The waveform in Fig. 2-10A is the display produced when a low-level, low-frequency signal is viewed in the presence of strong 50-megahertz radiation (BW-BEAM FINDER switch in FULL position). Fig. 2-10B shows the resultant CRT display when the high-frequency interference is reduced by setting the BW-BEAM FINDER switch to the 5 MHz position.

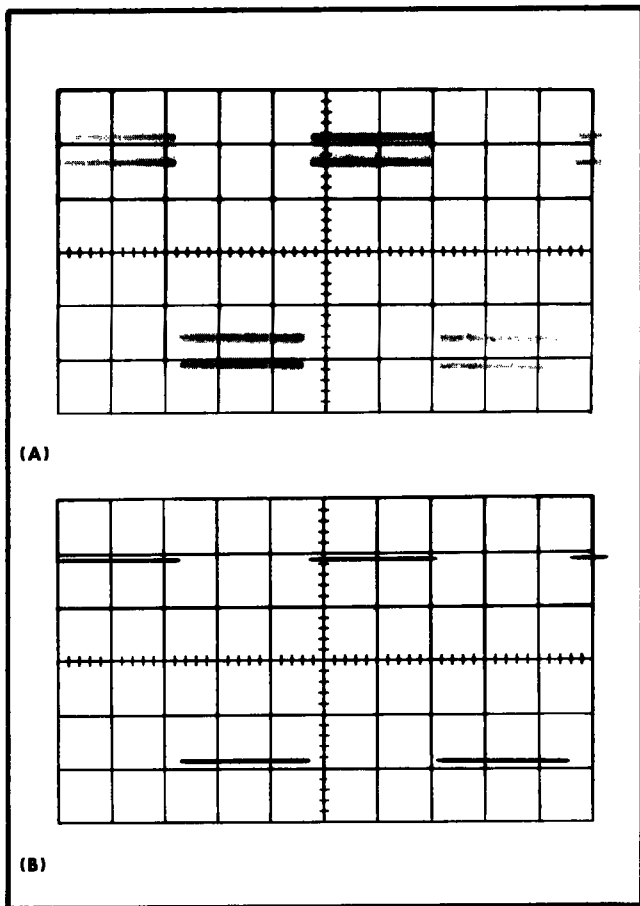

Fig. 2-10. (A) CRT display showing high-frequency interference when attempting to view low-level, low-frequency signal, (B) resultant display when BW-BEAM FINDER switch is set to 5 MHz position.

Channel 1 Output and Cascaded Operation

If a lower deflection factor than provided by the VOLTS/DIV switches is desired, Channel 1 can be used as a wide-band preamplifier for Channel 2. Apply the input signal to the INPUT CH 1 connector. Connect a 50-ohm BNC

cable (18-inch cable for maximum cascaded frequency response) between the CH 1 OUT connector on the side panel and the INPUT CH 2 connector. Set the MODE switch to CH 2 and the TRIGGER switch to NORM. With both VOLTS/DIV switches set to 5 mV, the deflection factor is less than one millivolt/division.

To provide calibrated one millivolt/division deflection factor, connect the Calibrator signal to the INPUT CH 1 connector. Set the CH 1 VOLTS/DIV switch to 1 and the CH 2 VOLTS/DIV switch to 5 mV. Adjust the CH 2 VARIABLE control to produce a display exactly five divisions in amplitude. The cascaded deflection factor is determined by dividing the CH 1 VOLTS/DIV switch setting by 5 (CH 2 VOLTS/DIV switch and CH 2 VARIABLE control remain as set above). For example, with the CH 1 VOLTS/DIV switch set to 5 mV, the calibrated deflection factor will be one millivolt/division; CH 1 VOLTS/DIV switch set to 10 mV, 2 millivolts/division, etc.

The following operating considerations and basic applications may suggest other uses for this feature.

1. If AC coupling is desired, set the Channel 1 Input Coupling switch to AC and leave the Channel 2 Input Coupling switch set to DC. When both Input Coupling switches are set to DC, DC signal coupling is provided.

2. Keep the CH 1 and CH 2 POSITION controls set near midrange. If the input signal has a DC level which necessitates one of the POSITION controls being turned away from midrange, correct operation can be obtained by keeping the CH 2 POSITION control near midrange and using the CH 1 POSITION control to position the trace near the desired location. Then, use the CH 2 POSITION control for exact positioning. This method will keep both Input Preamps operating within their linear range.

3. The output voltage at the CH 1 OUT connector is at least 25 millivolts/division of CRT display in all CH 1 VOLTS/DIV switch positions.

4. The MODE switch and CH 1 VARIABLE control have no effect on the signal available at the CH 1 OUT connector.

5. The Channel 1 Input Preamp can be used as an impedance matching stage with or without voltage gain. The input resistance is one megohm and the output resistance is about 30 ohms.

6. The output level at the CH 1 OUT connector is about 0 volt DC for a 0 volt DC input level (CH 1 POSITION control centered). The CH 1 POSITION control can be used to center the output signal within the dynamic range of the amplifier.

7. If dual-trace operation is used, the signal applied to the INPUT CH 1 connector is displayed when Channel 1 is turned on. When Channel 2 is turned on, the amplified signal is displayed. Thus, the input signal can be monitored by Channel 1 while the amplified signal is displayed by Channel 2.

8. In special applications where the flat frequency response of the Type 454 is not desired, a filter inserted between the CH 1 OUT and INPUT CH 2 connectors allows the oscilloscope to essentially take on the frequency response of the filter. Combined with method 7, the input

Operating Instructions—Type 454/R454

can be monitored by Channel 1 and the filtered signal displayed by Channel 2.

9. By using Channel 1 as a $5\times$ low-level voltage pre-amplifier (5 mV position), the signal available at the CH 1 OUT connector can be used for any application where a low-impedance preamplified signal is needed. Remember that if a 50-ohm load impedance is used, the output signal amplitude is about one-half.

Algebraic Addition

General. The ADD position of the MODE switch can be used to display the sum or difference of two signals, for common-mode rejection to remove an undesired signal, or for DC offset (applying a DC voltage to one channel to offset the DC component of a signal on the other channel).

The common-mode rejection ratio of the Type 454 is greater than 10:1 at 50 megahertz for signal amplitudes up to eight times the VOLTS/DIV switch setting. Rejection ratios of 100:1 can typically be achieved between DC and five megahertz by careful adjustment of the gain of either channel while observing the displayed common-mode signal.

Deflection Factor. The overall deflection in the ADD position of the MODE switch when both VOLTS/DIV switches are set to the same position is the same as the deflection factor indicated by either VOLTS/DIV switch. The amplitude of an added mode display can be determined directly from the resultant CRT deflection multiplied by the deflection factor indicated by either VOLTS/DIV switch. However, if the CH 1 and CH 2 VOLTS/DIV switches are set to different deflection factors, the resultant voltage is difficult to determine from the CRT display. In this case, the voltage amplitude of the resultant display can be determined accurately only if the amplitude of the signal applied to either channel is known.

Precautions. The following general precautions should be observed when using the ADD mode.

1. Do not exceed the input voltage rating of the Type 454.
2. Do not apply signals that exceed an equivalent of about eight times the VOLTS/DIV switch setting. For example, with a VOLTS/DIV switch setting of .5, the voltage applied to that channel should not exceed about four volts. Larger voltages may distort the display.
3. Use CH 1 and CH 2 POSITION control settings which most nearly position the signal of each channel to mid-screen when viewed in either the CH 1 or CH 2 positions of the MODE switch. This insures the greatest dynamic range for ADD mode operation.
4. For similar response from each channel, set the CH 1 and CH 2 Input Coupling switches to the same position.

Trigger Source

INT. For most applications, the sweep can be triggered internally. In the INT position of the Triggering SOURCE switch, the trigger signal is obtained from the Vertical Deflection System. The TRIGGER switch provides further selection of the internal trigger signal; obtained from the

Channel 1 signal in the CH 1 ONLY position, or from the displayed signal when in the NORM position. For single-trace displays of either channel, the NORM position provides the most convenient operation. However, for dual-trace displays, special considerations must be made to provide the correct display. See Dual-Trace Operation in this section for dual-trace triggering information.

LINE. The LINE position of the SOURCE switch connects a sample of the power-line voltage to the Trigger Generator. Line triggering is useful when the input signal is time-related (multiple or sub-multiple) to the line frequency. It is also useful for providing a stable display of a line-frequency component in a complex waveform.

EXT. An external signal connected to the EXT TRIG INPUT connector can be used to trigger the sweep in the EXT position of the SOURCE switch. The external signal must be time-related to the displayed signal for a stable display. An external trigger signal can be used to provide a triggered display when the internal signal is too low in amplitude for correct triggering, or contains signal components on which it is not desired to trigger. It is also useful when signal tracing in amplifiers, phase-shift networks, wave-shaping circuits, etc. The signal from a single point in the circuit under test can be connected to the EXT TRIG INPUT connector through a signal probe or cable. The sweep is then triggered by the same signal at all times and allows amplitude, time relationship or waveshape changes of signals at various points in the circuit to be examined without resetting the trigger controls.

EXT \div 10. Operation in the EXT \div 10 position is the same as described for EXT except that the external triggering signal is attenuated 10 times. Attenuation of high-amplitude external trigger signals is desirable to broaden the range of the Triggering LEVEL control. When the COUPLING switch is set to LF REJ, attenuation is about 20:1.

Trigger Coupling

Four methods of coupling the trigger signal to the trigger circuits can be selected with the Triggering COUPLING switches. Each position permits selection or rejection of the frequency components of the trigger signal which will trigger the sweep. Fig. 2-11 graphically illustrates the band of frequencies which each position of the coupling switch covers.

AC. The AC position blocks the DC component of the trigger signal. Signals with low-frequency components below about 30 hertz are attenuated. In general, AC coupling can be used for most applications. However, if the trigger signal contains unwanted frequency components or if the sweep is to be triggered at a low repetition rate or a DC level, one of the remaining COUPLING switch positions will provide a better display.

The triggering point in the AC position depends on the average voltage level of the trigger signal. If the trigger signals occur in a random fashion, the average voltage level will vary, causing the triggering point to vary also. This shift of the triggering point may be enough so it is impossible to maintain a stable display. In such cases, use DC coupling.

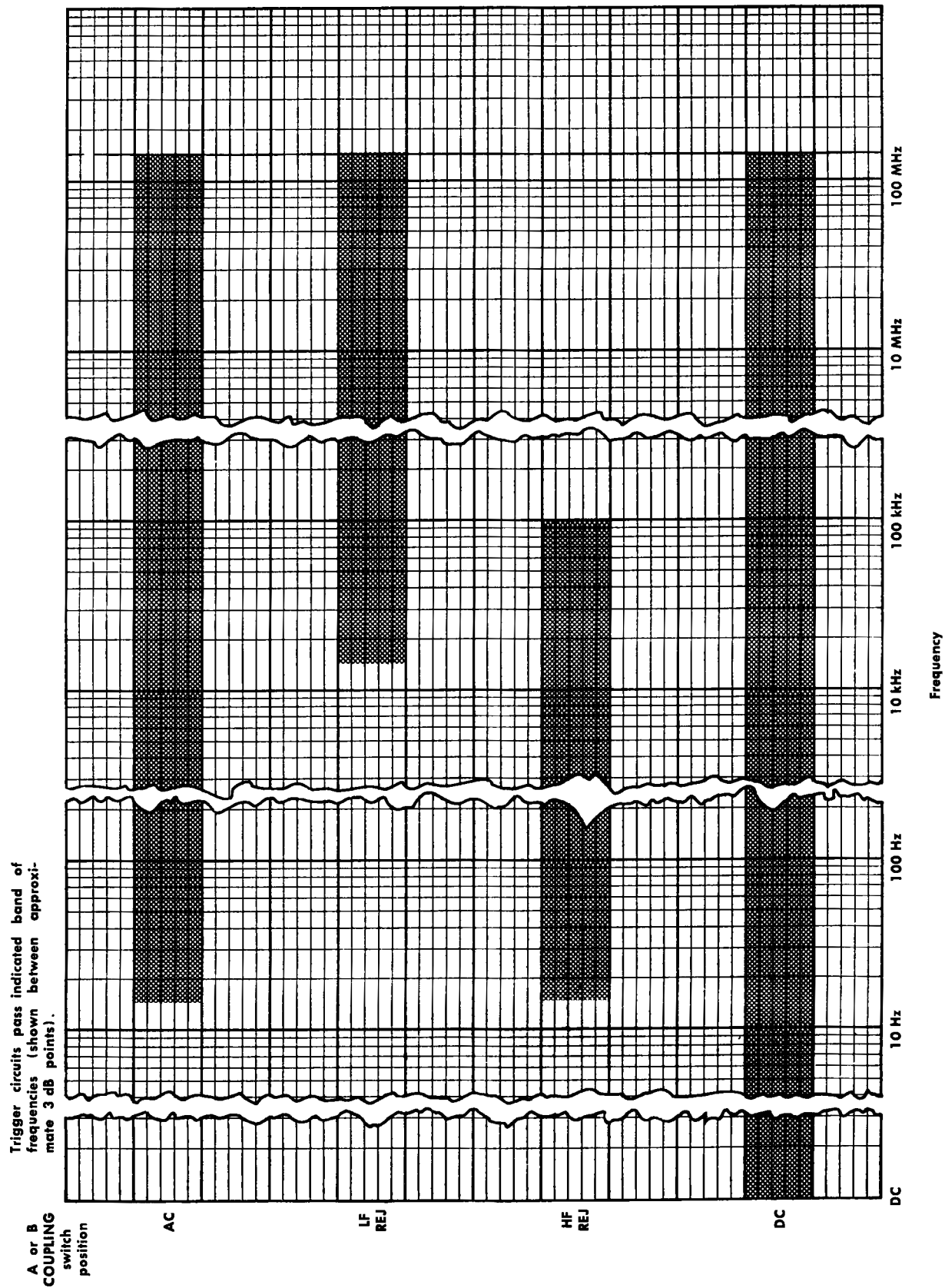

Fig. 2-11. Frequency range of each position of the A and B COUPLING switches

LF REJ. In the LF REJ position, DC is rejected and signals below about 50 kilohertz are attenuated. Therefore, the sweep will be triggered only by the higher-frequency components of the signal. This position is particularly useful for providing stable triggering if the trigger contains line-frequency components. Also, in the ALT position of the MODE switch, the LF REJ position provides the best display at fast sweep rates when comparing two unrelated signals (TRIGGER switch set to NORM).

HF REJ. The HF REJ position passes all low-frequency signals between about 30 hertz and 50 kilohertz. DC is rejected and signals outside the above range are attenuated. When triggering from complex waveforms, this position is useful for providing stable display of the low-frequency components.

DC. DC coupling can be used to provide stable triggering with low-frequency signals which would be attenuated in the AC position, or with low-repetition rate signals. The LEVEL control can be adjusted to provide triggering at the desired DC level on the waveform. When using internal triggering, the setting of the CH 1 and CH 2 POSITION controls affects the DC triggering level.

DC trigger coupling should not be used in the ALT dual-trace mode if the TRIGGER switch is set to NORM. If used, the sweep will trigger on the DC level of one trace and then either lock out completely or free run on the other trace. Correct DC triggering for this mode can be obtained with the TRIGGER switch set to CH 1 ONLY.

Trigger Slope

The Triggering SLOPE switch determines whether the trigger circuit responds on the positive-going or negative-going portion of the trigger signal. When the SLOPE switch is in the + (positive-going) position, the display starts with the positive-going portion of the waveform; in the - (negative-going) position, the display starts with the negative-going portion of the waveform (see Fig. 2-12). When several cycles of a signal appear in the display, the setting of the SLOPE switch is often unimportant. However, if only a certain portion of a cycle is to be displayed, correct setting of the SLOPE switch is important to provide a display which starts on the desired slope of the input signal.

Trigger Level

The Triggering LEVEL control determines the voltage level on the triggering waveform at which the sweep is triggered. When the LEVEL control is set in the + region, the trigger circuit responds at a more positive point on the trigger signal. When the LEVEL control is set in the - region, the trigger circuit responds at a more negative point on the trigger signal. Fig. 2-12 illustrates this effect with different settings of the SLOPE switch.

To set the LEVEL control, first select the Triggering SOURCE, COUPLING and SLOPE. Then set the LEVEL control fully counterclockwise and rotate it clockwise until the display starts at the desired point.

High-Frequency Stability

The HF STAB control (A only) is most useful at frequencies above about 40 megahertz or with signals which contain high-frequency components. If a stable display cannot be obtained using the A LEVEL control (trigger signal must have adequate amplitude), adjust the HF STAB control for minimum horizontal jitter in the display.

A Sweep Triggered Light

The A SWEEP TRIG'D light provides a convenient indication of the condition of the A Triggering circuit. If the A Triggering controls are correctly adjusted with an adequate trigger signal applied, this light is on. However, if the A LEVEL control is misadjusted, the A COUPLING or A SOURCE switches incorrectly set, or the trigger signal too low in amplitude, the A SWEEP TRIG'D LIGHT will be off. This feature can be used as a general indication of correct triggering. It is particularly useful when setting up the trigger circuits when a trigger signal is available without a trace displayed on the CRT; it also indicates that the A sweep is correctly triggered when operating in the B (DELAYED SWEEP) mode.

A Sweep Mode

AUTO TRIG. The AUTO TRIG position of the A SWEEP MODE switch provides a stable display when the A LEVEL control is correctly set (see Trigger Level in this section) and a trigger signal is available. The A SWEEP TRIG'D light indicates when the A Sweep Generator is triggered.

When the trigger repetition rate is less than about 20 hertz, or in the absence of an adequate trigger signal, the A Sweep Generator free runs to produce a reference trace. When an adequate trigger signal is again applied, the free-running condition ends and the A Sweep Generator is triggered to produce a stable display (with correct LEVEL control setting).

NORM TRIG. Operation in the NORM TRIG position when a trigger signal is applied is the same as in the AUTO TRIG position. However, when a trigger signal is not present, the A Sweep Generator remains off and there is no display. The A SWEEP TRIG'D light indicates when the A Sweep Generator is triggered.

Use the NORM TRIG mode to display signals with repetition rates below about 20 hertz. This mode provides an indication of an adequate trigger signal as well as the correctness of trigger control settings, since there is no display without proper triggering. Also, the A SWEEP TRIG'D light is off when the A sweep is not correctly triggered.

SINGLE SWEEP. When the signal to be displayed is not repetitive or varies in amplitude, shape or time, a conventional repetitive display may produce an unstable presentation. To avoid this, use the single-sweep feature of the Type 454. The SINGLE SWEEP mode can also be used to photograph a non-repetitive signal.

To use the SINGLE SWEEP mode, first make sure the trigger circuit will respond to the event to be displayed. Set the A SWEEP MODE switch to AUTO TRIG or NORM TRIG

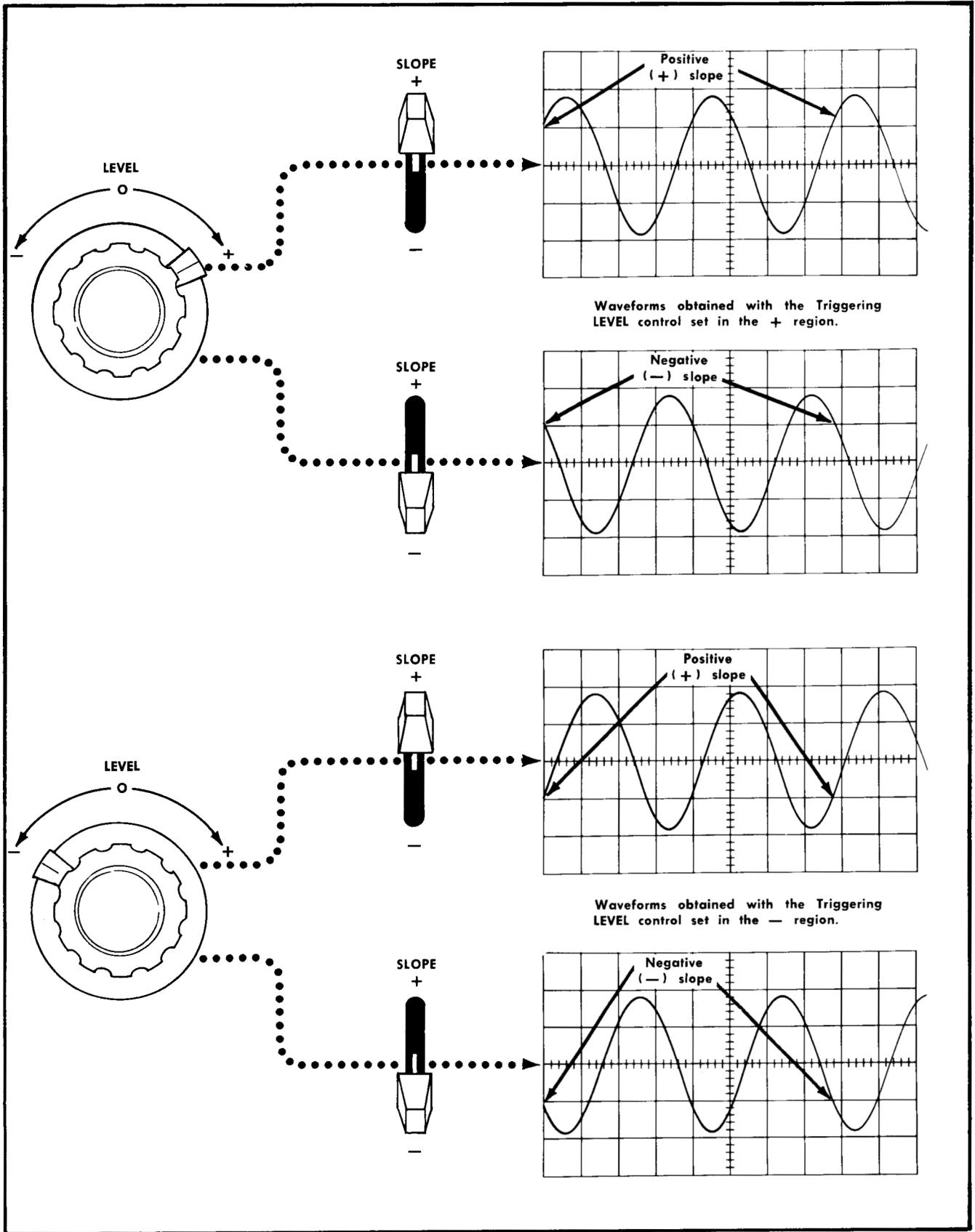

Fig. 2-12. Effects of LEVEL control and the A and B SLOPE switch on displayed waveform.

Operating Instructions—Type 454/R454

and obtain the best possible display in the normal manner (for random signals set the trigger circuit to trigger on a signal which is approximately the same amplitude and frequency as the random signal). Then, set the A SWEEP MODE switch to SINGLE SWEEP and press the RESET button. When the RESET button is pushed, the next trigger pulse initiates the sweep and a single trace will be presented on the screen. After this sweep is complete, the A Sweep Generator is "locked out" until reset. The RESET light located inside the RESET button lights when the A Sweep Generator circuit has been reset and is ready to produce a sweep; it goes out after the sweep is complete. To prepare the circuit for another single-sweep display, press the RESET button again.

Selecting Sweep Rate

The A AND B TIME/DIV switches select calibrated sweep rates for the Sweep Generators. The A and B VARIABLE controls provide continuously variable sweep rates between the settings of the TIME/DIV switches. Whenever the UNCAL A OR B light is on, the sweep rate of either A or B Sweep Generator, or both, is uncalibrated. The light is off when the A VARIABLE (front panel) and B TIME/DIV VARIABLE (side panel) controls are both set to the CAL position.

The sweep rate of the A Sweep Generator is bracketed by the two black lines on the clear plastic inner flange of the TIME/DIV switch (see Fig. 2-13). The B Sweep Generator sweep rate is indicated by the dot on the DELAYED SWEEP knob. When the dot on the outer knob is set to the same position as the lines on the inner knob, the two knobs lock together and the sweep rate of both Sweep Generators is changed at the same time. However, when the DELAYED SWEEP knob is pulled outward, the inner flange is disengaged and only the B Sweep Generator sweep rate is changed. This allows changing the delayed

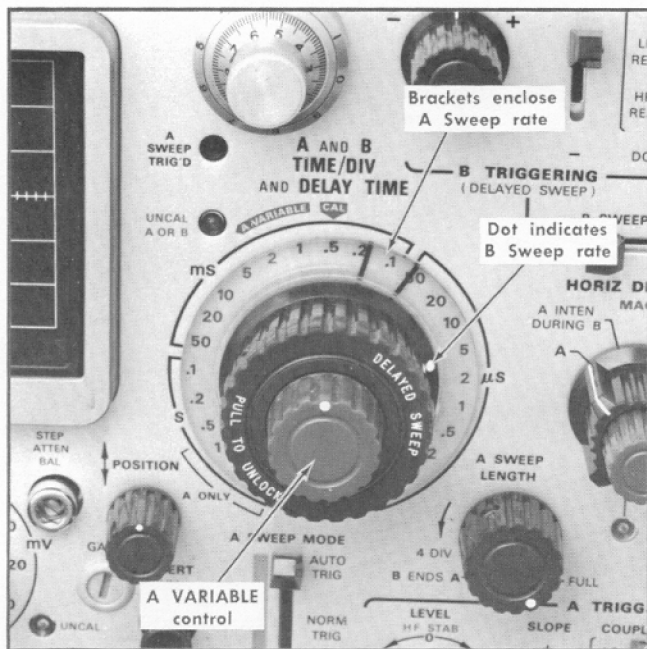

Fig. 2-13. A and B TIME/DIV switch.

sweep rate without changing the delay time determined by the A Sweep Generator.

When making time measurements from the graticule, the area between the first-division and ninth-division vertical lines provides the most linear time measurement (see Fig. 2-14). Therefore, the first and last division of the display should not be used when making accurate time measurements.

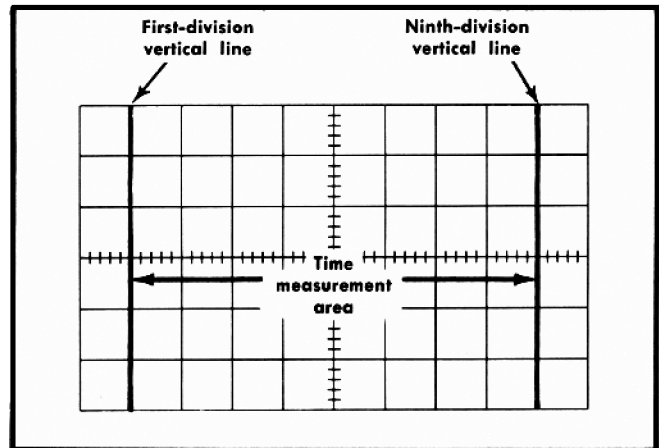

Fig. 2-14. Area of graticule used for accurate time measurements.

Sweep Magnification

The sweep magnifier expands the sweep ten times. The center division of the unmagnified display is the portion visible on the screen in magnified form (see Fig. 2-15). Equivalent length of the magnified sweep is more than 100 divisions; any 10-division portion may be viewed by adjusting the horizontal POSITION control to bring the desired portion onto the viewing area. The FINE (position) control is particularly useful when the magnifier is on, as it provides positioning in smaller increments for more precise control.

To use the magnified sweep, first move the portion of the display, which is to be expanded, to the center of the graticule. Then set the MAG switch to $\times 10$. The FINE position control can be adjusted to move the magnified portion to the desired position. The light located below the MAG switch is on whenever the magnifier is on.

When the MAG switch is set to $\times 10$, the sweep rate is determined by dividing the TIME/DIV switch setting by 10. For example, if the TIME/DIV switch is set to $.5 \mu\text{s}$, the magnified sweep rate is $0.05 \mu\text{s/division}$. The magnified sweep rate must be used for all time measurements when the MAG switch is set to $\times 10$. The magnified sweep rate is calibrated when the UNCAL A OR B light is off.

B (Delayed Sweep)

The B sweep (delayed sweep) is operable in the A INTEN DURING B and B (DELAYED SWEEP) positions of the HORIZ DISPLAY switch. The A sweep rate along with the DELAY-TIME MULTIPLIER dial determines the time that the B sweep is delayed. Sweep rate of the delayed portion is determined by the B TIME/DIV (DELAYED SWEEP) switch setting.

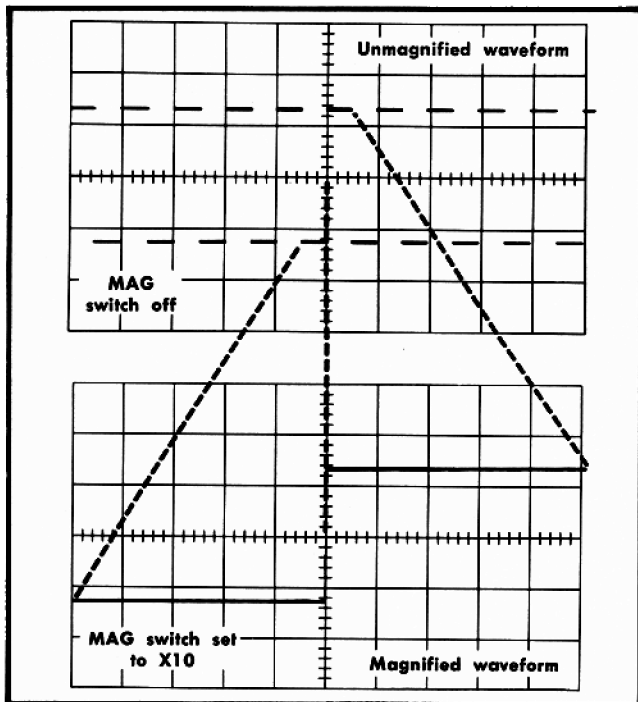

Fig. 2-15. Operation of sweep magnifier.

In the A INTEN DURING B position, the display will appear similar to Fig. 2-16A. The amount of delay time between the start of A sweep and the intensified portion is determined by the setting of the A TIME/DIV switch and the DELAY-TIME MULTIPLIER dial. For example, the delay time indicated by the DELAY-TIME MULTIPLIER dial setting shown in Fig. 2-17 is 3.55; this corresponds to 3.55 CRT divisions of A sweep. This reading multiplied by the setting of the A TIME/DIV switch gives the calibrated delay time before the start of the B sweep [Note: Due to system time delays, the delay start determined by the A sweep is accurate only between 50 seconds and one microsecond]. The intensified portion of the display is produced by the B sweep. The length of this portion is about 10 times the setting of the B TIME/DIV switch.

When the HORIZ DISPLAY switch is set to B (DELAYED SWEEP), only the intensified portion as viewed in the A INTEN DURING B position is displayed on the screen of the sweep rate indicated by the B TIME/DIV switch (see Fig 2-16B).

B Sweep Mode. The B SWEEP MODE switch provides two modes of delayed sweep. Fig. 2-18 illustrates the difference between these two modes. In the B STARTS AFTER DELAY TIME position, the B sweep is presented immediately after the delay time (see Fig. 2-18A). The B sweep is triggered at a selected level on A sweep to provide a delay for B sweep. Since this delay time is the same for each sweep, the display appears stable. In the TRIGGERABLE AFTER DELAY TIME position, the B sweep operates only when it is triggered after the selected delay time (see Fig. 2-18B). The B Triggering controls operate as described in this section.

Delayed Sweep Operation. To obtain a delayed sweep display use the following procedure.

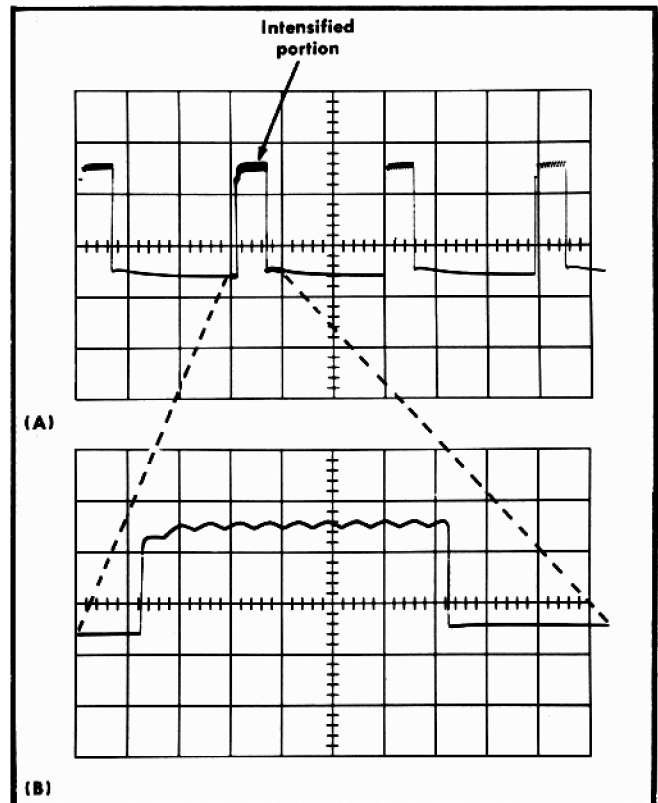

Fig. 2-16. (A) A INTEN DURING B display (A TIME/DIV, .5 ms; B TIME/DIV, 50 μ s), (B) B (DELAYED SWEEP) display.

1. Set the HORIZ DISPLAY switch to A INTEN DURING B.
2. Set the B SWEEP MODE switch to the desired setting. If TRIGGERABLE AFTER DELAY TIME is used, correct B Triggering is also necessary.
3. Set the delay time with the A TIME/DIV switch and the DELAY-TIME MULTIPLIER dial.
4. Pull the DELAYED SWEEP (B TIME/DIV) knob out and set to the desired sweep rate.

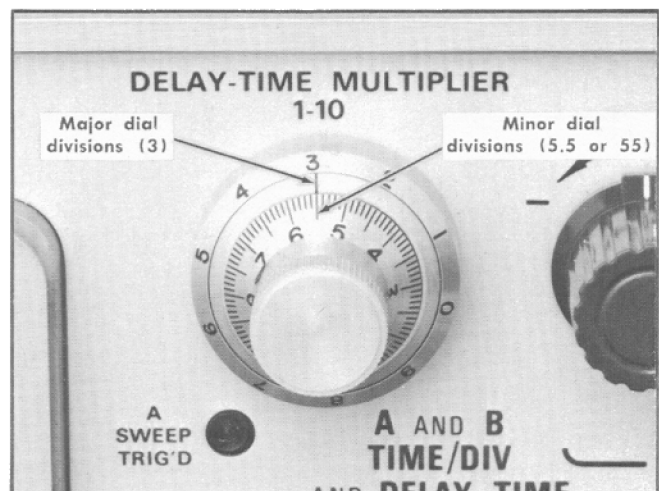

Fig. 2-17. DELAY-TIME MULTIPLIER dial. Reading shown: 3.55.

Operating Instructions—Type 454/R454

5. If the TRIGGERABLE AFTER DELAY TIME position is used, check the display for an intensified portion. Absence of the intensified zone indicates that B sweep is not correctly triggered.

6. Set the HORIZ DISPLAY switch to B (DELAYED SWEEP). The intensified zone shown in the A INTEN DURING B position is now displayed at the sweep rate selected by the B TIME/DIV switch.

Several examples of uses of the delayed sweep feature are given under Basic Applications in this section.

A Sweep Length. The A SWEEP LENGTH control is most useful when used with delayed sweep. As this control is rotated counterclockwise from the FULL position, the length of

the A sweep decreases until it is about four divisions long near the counterclockwise position (not in B ENDS A detent). The B ENDS A position produces a display which ends immediately following the B sweep (B sweep must end before the normal end of A sweep). The A SWEEP LENGTH control effectively increases the repetition rate of delayed sweep displays.

To use the A SWEEP LENGTH control, set the HORIZ DISPLAY switch to A INTEN DURING B and set the delay time and delayed sweep rate in the normal manner. Turn the A SWEEP LENGTH control counterclockwise until the sweep ends immediately following the intensified portion of the display. Then, set the HORIZ DISPLAY switch to B (DELAYED SWEEP). This method provides the maximum repetition rate for a given delayed sweep display. In the B ENDS A position, the maximum repetition rate is maintained automatically.

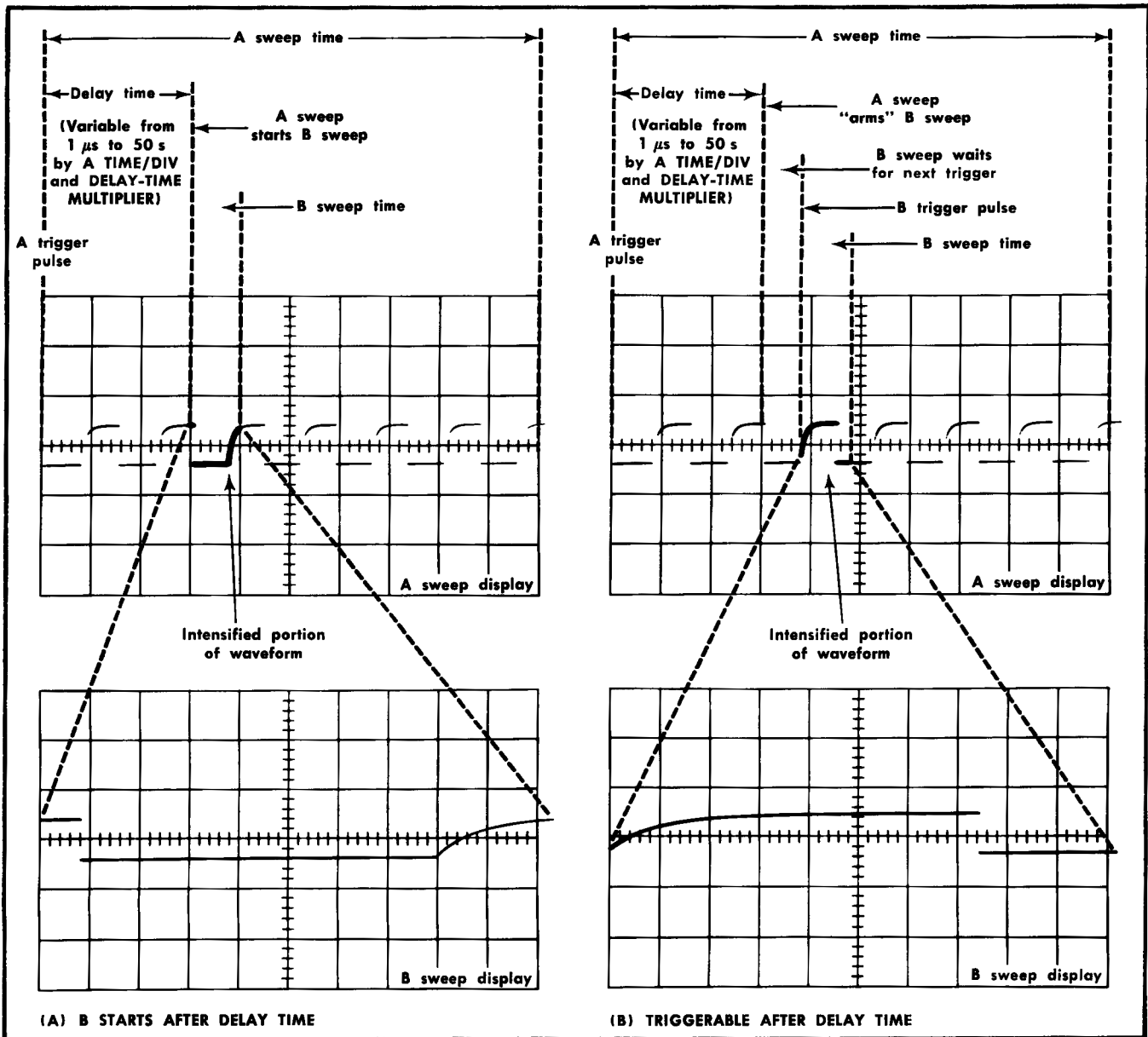

Fig. 2-18. Comparison of the delayed-sweep modes. (A) B STARTS AFTER DELAY TIME, (B) TRIGGERABLE AFTER DELAY TIME. In each display the B sweep is delayed a selected amount of time by the A sweep.

NOTE

Jitter can be introduced into the display and incorrect displays produced through the wrong usage of the A SWEEP LENGTH control. When using this control first obtain the best possible display in the FULL position. Then, set the control for the desired A sweep length. If jitter is evident in the display, readjust the Triggering controls or change the A SWEEP LENGTH control to a position that does not cause jitter.

X-Y Operation

In some applications, it is desirable to display one signal versus another (X-Y) rather than against time (internal sweep). The X-Y position of the HORIZ DISPLAY switch provides a means for applying an external signal to the horizontal amplifier for this type of display.

When the HORIZ DISPLAY switch is set to X-Y and the TRIGGER switch is set to CH 1 ONLY OR X-Y, the horizontal (X-axis) deflection is provided by the signal connected to the INPUT CH 1 OR X connector and the vertical deflection is provided by the signal connected to the INPUT CH 2 OR Y connector. The calibrated X-axis deflection is indicated by the CH 1 VOLTS/DIV switch; calibrated Y-axis deflection is indicated by the CH 2 VOLTS/DIV switch. For X-Y operation, the CH 1 POSITION control provides X-axis positioning and the CH 2 POSITION control provides Y-axis positioning.

Do not exceed the horizontal scan area of the graticule in the X-Y mode of operation. This mode can be used to measure phase differences up to about two megahertz. Above this frequency, the inherent phase shift in the system makes phase measurement difficult. To minimize phase shift in X-Y displays at the upper frequency limit, set the MAG switch to OFF.

To check and adjust the X-axis deflection accuracy, use the following procedure (Y-axis deflection accuracy is checked as given for vertical deflection under Vertical Gain Adjustment).

1. Set the HORIZ DISPLAY switch to X-Y.
2. Set the TRIGGER switch to CH 1 ONLY OR X-Y.
3. Connect the 1 V CAL 1 kHz connector to the INPUT CH 1 OR X connector with a BNC cable.
4. Set the CH 1 VOLTS/DIV switch to .2.
5. Advance the INTENSITY control until two dots are visible on the CRT.
6. Check that the dots are exactly five divisions apart. If not, adjust the X-GAIN (X-Y) adjustment (side panel) for exactly five divisions of deflection.

Sweep Generator Output Signals

A and B + GATE. The A and B + GATE output connectors (on side panel) provide a rectangular output pulse which is coincident with the sweep time of the respective sweep generator. This rectangular pulse is about +12 volts in amplitude (into high-impedance loads) with pulse duration the same as the respective sweep.

A Sweep. The A SWEEP connector (on side panel) provides a sample of the sawtooth sweep signal from the A Sweep Generator circuit. Amplitude of the sweep output signal is about +10 volts into a high-impedance load.

Intensity Modulation

Intensity (Z-axis) modulation can be used to relate a third item of electrical phenomena to the vertical (Y-axis) and the horizontal (X-axis) coordinates without changing the wave shape. The Z-axis modulating signal applied to the CRT circuit changes the intensity of the displayed waveform to provide this display. "Gray scale" intensity modulation can be obtained by applying signals which do not completely blank the display. Large amplitude signals of the correct polarity will completely blank the display; the sharpest display is provided by signals with a fast rise and fall. The voltage amplitude required for visible trace modulation depends on the setting of the INTENSITY control. At normal intensity level, a five-volt peak-to-peak signal produces a visible change in brightness. When the Z AXIS INPUT connector is not in use, keep the ground strap in place.

Time markers applied to the Z AXIS INPUT connector provide a direct time reference on the display. With uncalibrated horizontal sweep or X-Y mode operation, the time markers provide a means of reading time directly from the display. However, if the markers are not time-related to the displayed waveform, a single-sweep display should be used (for internal sweep only) to provide a stable display.

Calibrator

The one-kilohertz square-wave Calibrator of the Type 454 provides a convenient signal source for checking basic vertical gain and sweep timing. However, to provide maximum measurement accuracy, the adjustment procedure given in the Calibration section of this manual should be used when recalibrating the unit. The Calibrator output signal is also very useful for adjusting probe compensation as described in the probe instruction manual. In addition, the Calibrator can be used as a convenient signal source for application to external equipment.

Voltage. The Calibrator provides an accurate peak-to-peak square-wave voltage of one volt into a high impedance load. Output resistance is 250 ohms. The actual voltage across an external load resistor can be calculated in the same manner as with any series resistor combination (necessary only if the load resistance is less than about 50 kilohms).

Current. The current loop, located on the side panel, provides a five millampere peak-to-peak square-wave current which can be used to check and calibrate current-measuring probe systems. This current signal is obtained by clipping the probe around the current loop. The arrow above the PROBE LOOP indicates conventional current flow; i.e., from + to -.

Frequency. The Calibrator circuit uses frequency-stable components to maintain accurate frequency and constant duty cycle. Thus the Calibrator can be used for checking the basic sweep timing of the horizontal system.

Operating Instructions—Type 454/R454

Wave shape. The square-wave output signal of the Calibrator can be used as a reference wave shape when checking or adjusting the compensation of passive, high-resistance probes. Since the square-wave output from the Calibrator has a flat top, any distortion in the displayed waveform is due to the probe compensation.

BASIC APPLICATIONS

The following information describes the procedure and technique for making basic measurements with a Type 454 Oscilloscope. These applications are not described in detail since each application must be adapted to the requirements of the individual measurements. Familiarity with the Type 454 will permit these basic techniques to be applied to a wide variety of uses.

Peak-to-Peak Voltage Measurements—AC

To make a peak-to-peak voltage measurement, use the following procedure:

1. Connect the signal to either INPUT connector.
2. Set the MODE switch to display the channel used.
3. Set the VOLTS/DIV switch to display about five divisions of the waveform.
4. Set the Input Coupling switch to AC.

NOTE

For low-frequency signals below about 10 hertz, use the DC position.

5. Set the A Triggering controls to obtain a stable display. Set the TIME/DIV switch to a position that displays several cycles of the waveform.

6. Turn the vertical POSITION control so the lower portion of the waveform coincides with one of the graticule lines below the center horizontal line, and the top of the waveform is on the viewing area. Move the display with the horizontal POSITION control, so one of the upper peaks lies near the center vertical line (see Fig. 2-19).

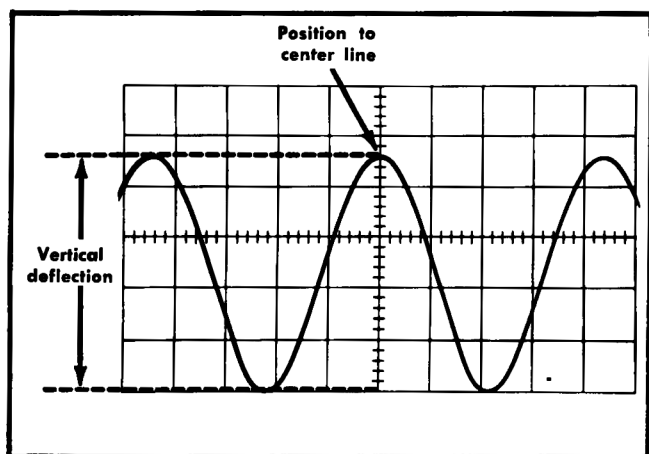

Fig. 2-19. Measuring peak-to-peak voltage of a waveform.

7. Measure the divisions of vertical deflection from peak to peak. Make sure the VARIABLE VOLTS/DIV control is in the CAL position.

NOTE

This technique may also be used to make measurements between two points on the waveform rather than peak to peak.

8. Multiply the distance measured in step 7 by the VOLTS/DIV switch setting. Also include the attenuation factor of the probe, if any.

Example. Assume a peak-to-peak vertical deflection of 4.6 divisions (see Fig. 2-19) using a $10\times$ attenuator probe and a VOLTS/DIV switch setting of .5.

Using the formula:

$$\text{Volts Peak to Peak} = \text{vertical deflection (divisions)} \times \text{VOLTS/DIV setting} \times \text{probe attenuation factor}$$

Substituting the given values:

$$\text{Volts Peak to Peak} = 4.6 \times 0.5 \text{ V} \times 10$$

The peak-to-peak voltage is 23 volts.

Instantaneous Voltage Measurements—DC

To measure the DC level at a given point on a waveform, use the following procedure:

1. Connect the signal to either INPUT connector.
2. Set the MODE switch to display the channel used.
3. Set the VOLTS/DIV switch to display about five divisions of the waveform.
4. Set the Input Coupling switch to GND.
5. Set the A SWEEP MODE switch to AUTO TRIG.
6. Position the trace to the bottom line of the graticule or other reference line. If the voltage to be measured is negative with respect to ground, position the trace to the top line of the graticule. Do not move the vertical POSITION control after this reference line has been established.

NOTE

To measure a voltage level with respect to a voltage other than ground, make the following changes in step 6: Set the Input Coupling switch to DC and apply the reference voltage to the INPUT connector. Then position the trace to the reference line.

7. Set the Input Coupling switch to DC. The ground reference line can be checked at any time by switching to the GND position.

8. Set the A Triggering controls to obtain a stable display. Set the TIME/DIV switch to a setting that displays several cycles of the signal.

9. Measure the distance in divisions between the reference line and the point on the waveform at which the DC level is to be measured. For example, in Fig. 2-20 the measurement is made between the reference line and point A.

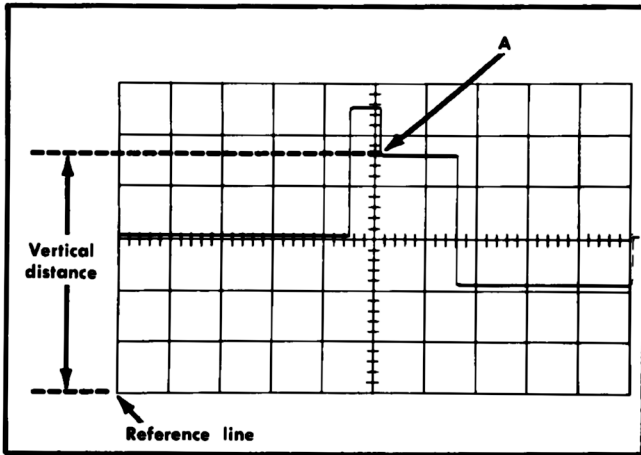

Fig. 2-20. Measuring instantaneous DC voltage with respect to a reference voltage.

10. Establish the polarity of the signal. If the waveform is above the reference line, the voltage is positive; below the line, negative (when the INVERT switch is pushed in if using Channel 2).

11. Multiply the distance measured in step 9 by the VOLTS/DIV switch setting. Include the attenuation factor of the probe, if any.

Example. Assume that the vertical distance measured is 4.6 divisions (see Fig. 2-20), the waveform is above the reference line, using a 10× attenuator probe and a VOLTS/DIV switch setting of 2.

Using the formula:

$$\text{Instantaneous Voltage} = \text{vertical distance (divisions)} \times \text{polarity} \times \text{VOLTS/DIV setting} \times \text{probe attenuation factor}$$

Substituting the given values:

$$\text{Instantaneous Voltage} = 4.6 \times +1 \times 2\text{V} \times 10$$

The instantaneous voltage is +92 volts.

Voltage Comparison Measurements

In some applications it may be necessary to establish a set of deflection factors other than those indicated by the VOLTS/DIV switch. This is useful for comparing signals to a reference voltage amplitude. To establish a new set of deflection factors based upon a specific reference amplitude, proceed as follows.

1. Apply the reference signal of known amplitude to either INPUT connector. Set the MODE switch to display the channel used. Using the VOLTS/DIV switch and the VARIABLE control, adjust the display for an exact number of divisions. Do not move the VARIABLE VOLTS/DIV control after obtaining the desired deflection.

2. Divide the amplitude of the reference signal (volts) by the product of the deflection in divisions (established in step

1) and the VOLTS/DIV switch setting. This is the Deflection Conversion Factor.

$$\text{Deflection Conversion Factor} = \frac{\text{reference signal amplitude (volts)}}{\text{deflection (divisions)} \times \text{VOLTS/DIV setting}}$$

3. To establish an Adjusted Deflection Factor at any setting of the VOLTS/DIV switch, multiply the VOLTS/DIV switch setting by the Deflection Conversion Factor established in step 2.

$$\text{Adjusted Deflection Factor} = \text{VOLTS/DIV setting} \times \text{Deflection Conversion Factor}$$

This Adjusted Deflection Factor applies only to the channel used and is correct only if the VARIABLE VOLTS/DIV control is not moved from the position set in step 1.

4. To determine the peak-to-peak amplitude of a signal compared to a reference, disconnect the reference and apply the signal to the INPUT connector.

5. Set the VOLTS/DIV switch to a setting that provides sufficient deflection to make the measurement. Do not readjust the VARIABLE VOLTS/DIV control.

6. Measure the vertical deflection in divisions and determine the amplitude by the following formula:

$$\text{Signal Amplitude} = \text{Adjusted Deflection Factor} \times \text{deflection (divisions)}$$

Example. Assume a reference signal amplitude of 30 volts, a VOLTS/DIV setting of 5 and a deflection of four divisions. Substituting these values in the Deflection Conversion Factor formula (step 2):

$$\text{Deflection Conversion Factor} = \frac{30\text{V}}{4 \times 5} = 1.5$$

Then, with a VOLTS/DIV switch setting of 10, the Adjusted Deflection Factor (step 3) is:

$$\text{Adjusted Deflection Factor} = 10\text{V} \times 1.5 = 15\text{ volts/division}$$

To determine the peak-to-peak amplitude of an applied signal which produces a vertical deflection of five divisions, use the Signal Amplitude formula (step 6):

$$\text{Signal Amplitude} = 15\text{V} \times 5 = 75\text{ volts}$$

Time-Duration Measurements

To measure time between two points on a waveform, use the following procedure.

1. Connect the signal to either INPUT connector.
2. Set the MODE switch to display the channel used.
3. Set the VOLTS/DIV switch to display about five divisions of the waveform.
4. Set the A Triggering controls to obtain a stable display.

Operating Instructions—Type 454/R454

5. Set the TIME/DIV switch to the fastest sweep rate that displays less than eight divisions between the time measurement points (see Fig. 2-21). See the topic entitled Selecting Sweep Rate in this section concerning non-linearity of first and last divisions of display.

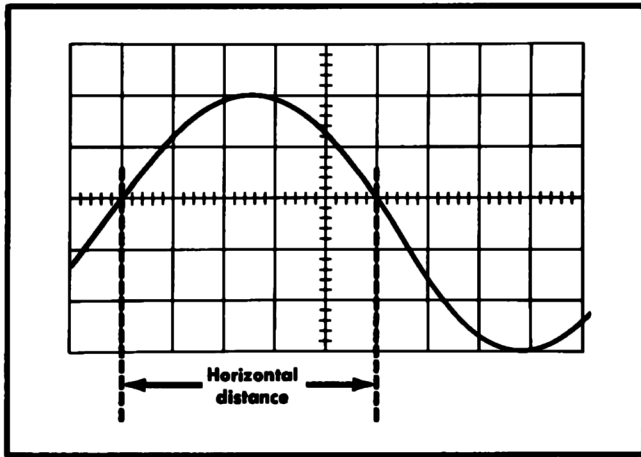

Fig. 2-21. Measuring the time duration between points on a waveform.

6. Adjust the vertical POSITION control to move the points between which the time measurement is made to the center horizontal line.

7. Adjust the horizontal POSITION control to center the display within the center eight divisions of the graticule.

8. Measure the horizontal distance between the time measurement points. Be sure the A VARIABLE control is set to CAL.

9. Multiply the distance measured in step 8 by the setting of the TIME/DIV switch. If sweep magnification is used, divide this answer by 10.

Example. Assume that the distance between the time measurement points is five divisions (see Fig. 2-21) and the TIME/DIV switch is set to .1 ms with the magnifier off.

Using the formula:

$$\text{Time Duration} = \frac{\text{horizontal distance (divisions)} \times \text{TIME/DIV setting}}{\text{magnification}}$$

Substituting the given values:

$$\text{Time Duration} = \frac{5 \times 0.1 \text{ ms}}{1}$$

The time duration is 0.5 milliseconds.

Frequency Measurement

The time measurement technique can also be used to determine the frequency of a signal. The frequency of a periodically recurrent signal is the reciprocal of the time duration (period) of one cycle.

Use the following procedure:

1. Measure the time duration of one cycle of the waveform as described in the previous application.
2. Take the reciprocal of the time duration to determine the frequency.

Example. The frequency of the signal shown in Fig. 2-21 which has a time duration of 0.5 milliseconds is:

$$\text{Frequency} = \frac{1}{\text{time duration}} = \frac{1}{0.5 \text{ ms}} = 2 \text{ kHz}$$

Risetime Measurements

Risetime measurements employ basically the same techniques as time-duration measurements. The main difference is the points between which the measurement is made. The following procedure gives the basic method of measuring risetime between the 10% and 90% points of the waveform. Falltime can be measured in the same manner on the trailing edge of the waveform.

1. Connect the signal to either INPUT connector.
2. Set the MODE switch to display the channel used.
3. Set the VOLTS/DIV switch and the VARIABLE control to produce a display an exact number of divisions in amplitude.
4. Center the display about the center horizontal line.
5. Set the TIME/DIV switch to the fastest sweep rate that displays less than eight divisions between the 10% and 90% points on the waveform.
6. Determine the 10% and 90% points on the rising portion of the waveform. The figures given in Table 2-2 are for the points 10% up from the start of the rising portion and 10% down from the top of the rising portion (90% point).

TABLE 2-2

| Vertical display (divisions) | 10% and 90% points | Divisions vertically between 10% and 90% point |
|------------------------------|--------------------|--|
| 4 | 0.4 division | 3.2 |
| 5 | 0.5 division | 4.0 |
| 6 | 0.6 division | 4.8 |

7. Adjust the horizontal POSITION control to move the 10% point of the waveform to the first graticule line. For example, with a five-division display as shown in Fig. 2-22, the 10% point is 0.5 division up from the start of the rising portion.

8. Measure the horizontal distance between the 10% and 90% points. Be sure the A VARIABLE control is set to CAL.

9. Multiply the distance measured in step 8 by the setting of the TIME/DIV switch. If sweep magnification is used, divide this answer by 10.

Example. Assume that the horizontal distance between the 10% and 90% points is four divisions (see Fig. 2-22) and the TIME/DIV switch is set to 1 μ s with the MAG switch

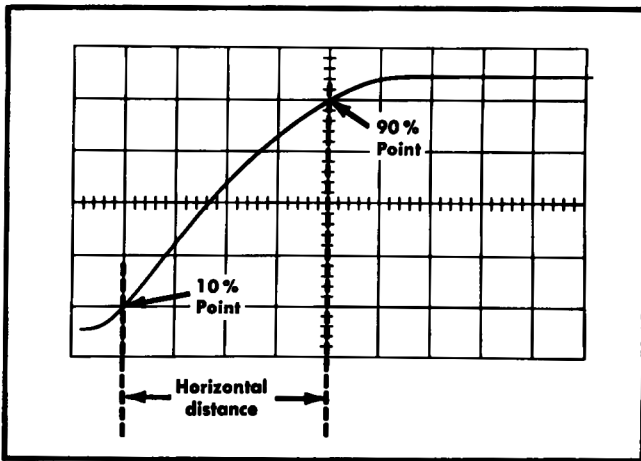

Fig. 2-22. Measuring risetime.

set to $\times 10$. Applying the time duration formula to rise-time:

$$\text{Risetime (Time Duration)} = \frac{\text{horizontal (divisions) distance} \times \text{TIME/DIV setting}}{\text{magnification}}$$

Substituting the given values:

$$\text{Risetime} = \frac{4 \times 1 \mu\text{s}}{10}$$

The risetime is 0.4 microsecond.

Time-Difference Measurements

The calibrated sweep rate and dual-trace features of the Type 454 allow measurement of time difference between two separate events. To measure time difference, use the following procedure.

1. Set the Input Coupling switches to the desired coupling positions.
2. Set the MODE switch to either CHOP or ALT. In general, CHOP is more suitable for low-frequency signals and the ALT position is more suitable for high-frequency signals. More information on determining the mode is given under Dual-Trace Operation in this section.
3. Set the TRIGGER switch to CH 1 ONLY.
4. Connect the reference signal to INPUT CH 1 and the comparison signal to INPUT CH 2. The reference signal should precede the comparison signal in time. Use coaxial cables or probes which have equal time delay to connect the signals to the INPUT connectors.
5. If the signals are of opposite polarity, pull out the INVERT switch to invert the Channel 2 display (signals may be of opposite polarity due to 180° phase difference; if so, take this into account in the final calculation).
6. Set the VOLTS/DIV switches to produce four- or five-division displays.
7. Set the A LEVEL control for a stable display.

8. If possible, set the TIME/DIV switch for a sweep rate which shows three or more divisions between the two waveforms.

9. Adjust the vertical POSITION controls to center each waveform (or the points on the display between which the measurement is made) in relation to the center horizontal line.

10. Adjust the horizontal POSITION control so the Channel 1 (reference) waveform crosses the center horizontal line at a vertical graticule line.

11. Measure the horizontal difference between the Channel 1 waveform and the Channel 2 waveform (see Fig. 2-23).

12. Multiply the measured difference by the setting of the TIME/DIV switch. If sweep magnification is used, divide this answer by 10.

Example. Assume that the TIME/DIV switch is set to $50 \mu\text{s}$, the MAG switch to $\times 10$ and the horizontal difference between waveforms is 4.5 divisions (see Fig. 2-23).

Using the formula:

$$\text{Time Delay} = \frac{\text{TIME/DIV setting} \times \text{horizontal difference (divisions)}}{\text{magnification}}$$

Substituting the given values:

$$\text{Time Delay} = \frac{50 \mu\text{s} \times 4.5}{10}$$

The time delay is 22.5*microseconds.

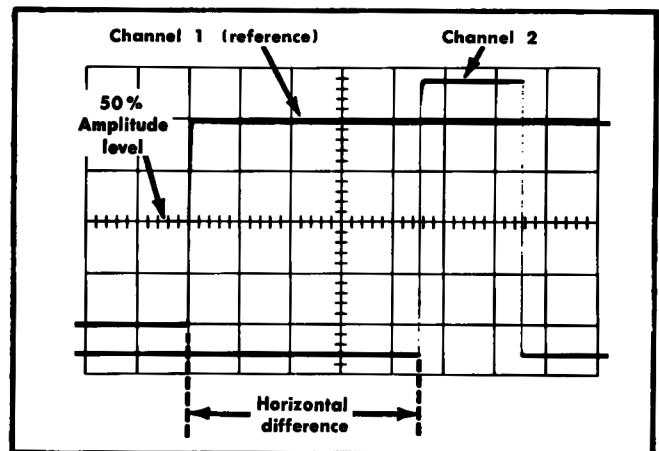

Fig. 2-23. Measuring time difference between two pulses.

Delayed Sweep Time Measurement

The delayed sweep mode can be used to make accurate time measurements. The following measurement determines the time difference between two pulses displayed on the same trace. This application may also be used to measure time difference from two different sources (dual-trace) or to measure time duration of a single pulse. Fig. 1-5 graphically shows the measurement accuracy with any given difference between DELAY-TIME MULTIPLIER dial settings.

Operating Instructions—Type 454/R454

1. Connect the signal to either INPUT connector. Set the MODE switch to display the channel used.
2. Set the VOLTS/DIV switch to produce a display about four divisions in amplitude.
3. If possible, set the A TIME/DIV switch to a sweep rate which displays about eight divisions between the pulses.
4. Adjust the A Triggering controls for a stable display.
5. Set the HORIZ DISPLAY switch to A INTEN DURING B and the B SWEEP MODE switch to B STARTS AFTER DELAY TIME.
6. Set the B TIME/DIV switch to a setting 1/1000th of the A TIME/DIV sweep rate. This produces an intensified portion about 0.1 division in length.
7. Turn the DELAY-TIME MULTIPLIER dial to move the intensified portion to the first pulse.
8. Set the HORIZ DISPLAY switch to B (DELAYED SWEEP).
9. Adjust the DELAY-TIME MULTIPLIER dial to move the pulse (or the rising portion) to the center vertical line. Note the setting of the DELAY-TIME MULTIPLIER dial.
10. Turn the DELAY-TIME MULTIPLIER dial clockwise until the second pulse is positioned to this same point (if several pulses are displayed, return to the A INTEN DURING B position to locate the correct pulse). Again note the dial setting.
11. Subtract the first dial setting from the second and multiply by the delay time shown by the A TIME/DIV switch. This is the time interval between the pulses.

Example. Assume the first dial setting is 1.31 and the second dial setting is 8.81 with the A TIME/DIV switch set to $0.2 \mu\text{s}$ (see Fig. 2-24).

Using the formula:

$$\text{Time Difference (delayed sweep)} = \left[\begin{array}{c} \text{second dial} \\ \text{setting} \end{array} - \begin{array}{c} \text{first dial} \\ \text{setting} \end{array} \right] \times \begin{array}{c} \text{delay time} \\ \text{(A TIME/DIV} \\ \text{setting)} \end{array}$$

Substituting the given values:

$$\text{Time Difference} = (8.81 - 1.31) \times 0.2 \mu\text{s}.$$

The time difference is 1.5 microseconds.

Delayed Sweep Magnification

The delayed sweep feature of the Type 454 can be used to provide higher apparent magnification than is provided by the MAG switch. The sweep rate of the DELAYED SWEEP (B sweep) is not actually increased; the apparent magnification is the result of delaying the B sweep an amount of time selected by the A TIME/DIV switch and the DELAY-TIME MULTIPLIER dial before the display is presented at the sweep rate selected by the B TIME/DIV switch. The following method uses the B STARTS AFTER DELAY TIME position to allow the delayed portion to be positioned with the DELAY-TIME MULTIPLIER dial. If there is too much jitter in the delayed display, use the Triggered Delayed Sweep Magnification procedure which follows.

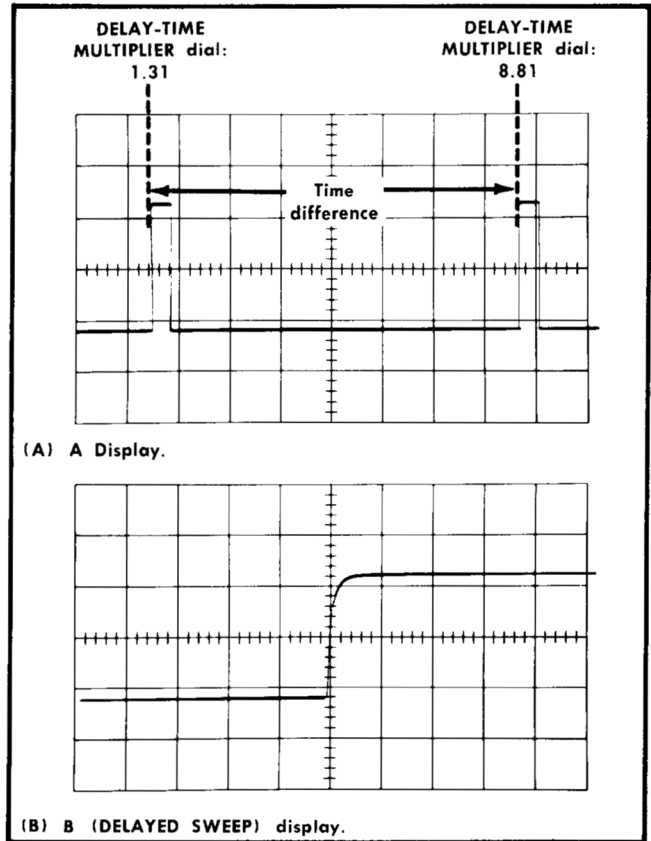

Fig. 2-24. Measuring time difference using delayed sweep.

1. Connect the signal to either INPUT connector. Set the MODE switch to display the channel used.
2. Set the VOLTS/DIV switch to produce a display about four divisions in amplitude.
3. Set the A TIME/DIV switch to a sweep rate which displays the complete waveform.
4. Adjust the A Triggering controls for a stable display.
5. Set the HORIZ DISPLAY switch to A INTEN DURING B and the B SWEEP MODE switch to B STARTS AFTER DELAY TIME.
6. Position the start of the intensified portion with the DELAY-TIME MULTIPLIER dial to the part of the display to be magnified.
7. Set the B TIME/DIV switch to a setting which intensifies the full portion to be magnified. The start of the intensified trace remains as positioned above.
8. Set the HORIZ DISPLAY switch to B (DELAYED SWEEP).
9. Time measurements can be made from the display in the conventional manner. Sweep rate is determined by the setting of the B TIME/DIV switch.
10. The apparent sweep magnification can be calculated by dividing the A TIME/DIV switch setting by the B TIME/DIV switch setting.

Example. The apparent magnification of the display shown in Fig. 2-25 with an A TIME/DIV switch setting of .1 ms and a B TIME/DIV switch setting of 1 μ s is:

$$\text{Apparent Magnification (Delayed Sweep)} = \frac{\text{A TIME/DIV setting}}{\text{B TIME/DIV setting}}$$

Substituting the given values:

$$\text{Apparent Magnification} = \frac{1 \times 10^{-4}}{1 \times 10^{-6}}$$

The apparent magnification is 100 times.

Triggered Delayed Sweep Magnification. The delayed sweep magnification method just described may produce too much jitter at high apparent magnification ranges. The TRIGGERABLE AFTER DELAY TIME position of the B SWEEP MODE switch provides a more stable display since the delayed display is triggered at the same point each time.

1. Set up the display as given in steps 1 through 7 described above.
2. Set the B SWEEP MODE switch to TRIGGERABLE AFTER DELAY TIME.

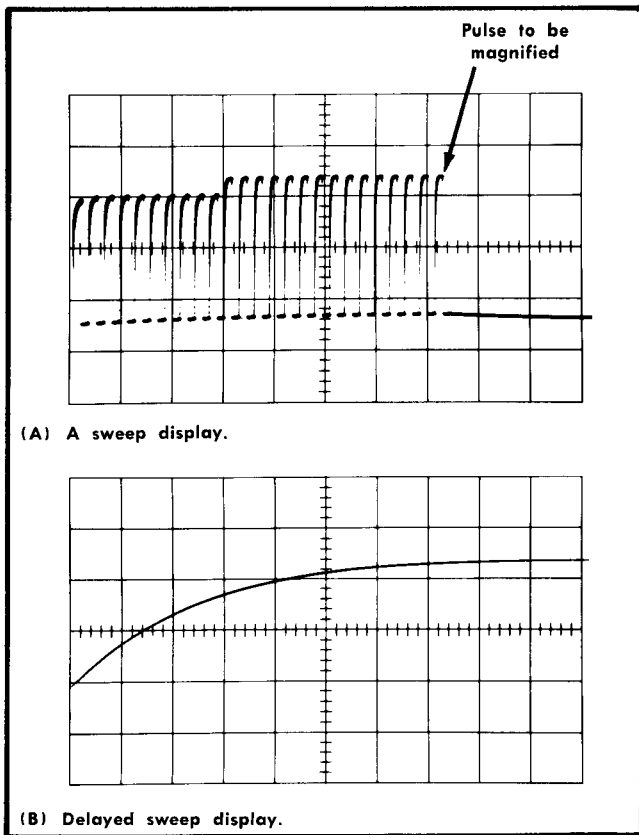

Fig. 2-25. Using delayed sweep for sweep magnification.

3. Adjust the B LEVEL control so the intensified portion on the trace is stable. (If an intensified portion cannot be obtained, see step 4.)
4. Inability to intensify the desired portion indicates that the signal does not meet the triggering requirements. If

the condition cannot be remedied with the B Triggering controls or by increasing the display amplitude (lower VOLTS/DIV setting), trigger B sweep externally.

5. When the correct portion is intensified, set the HORIZ DISPLAY switch to B (DELAYED SWEEP). Slight readjustment of the B LEVEL control may be necessary for a stable display.
6. Measurement and magnification are as described above.

Displaying Complex Signals Using Delayed Sweep

Complex signals often consist of a number of individual events of differing amplitudes. Since the trigger circuits are sensitive to changes in signal amplitude, a stable display can normally be obtained only when the sweep is triggered by the event(s) having the greatest amplitude. However, this may not produce the desired display of a lower-amplitude portion which follows the triggering event. The delayed sweep feature provides a means of delaying the start of the B sweep by a selected amount following the event which triggers the A Sweep Generator. Then, the part of the waveform which contains the information of interest can be displayed.

Use the following procedure:

1. Connect the signal to either INPUT connector. Set the MODE switch to display the channel used.
2. Set the VOLTS/DIV switch to produce a display about four divisions in amplitude.
3. Set the A TIME/DIV switch to a sweep rate which displays the complete waveform.
4. Adjust the A Triggering controls for a stable display.
5. Set the HORIZ DISPLAY switch to A INTEN DURING B and the B SWEEP MODE switch to B STARTS AFTER DELAY TIME.
6. Position the start of the intensified portion with the DELAY-TIME MULTIPLIER dial to the part of the display to be magnified.
7. Set the B TIME/DIV switch to a setting which intensifies the full portion to be magnified. The start of the intensified trace will remain as positioned above.
8. Set the HORIZ DISPLAY switch to B (DELAYED SWEEP).
9. Time measurements can be made from the display in the conventional manner. Sweep rate is determined by the setting of the B TIME/DIV switch.

Example. Fig. 2-26 shows a complex waveform as displayed on the CRT. The circled portion of the waveform cannot be viewed in any greater detail because the sweep is triggered by the larger amplitude pulses at the start of the display and a faster sweep rate moves this area of the waveform off the viewing area. The second waveform shows the area of interest magnified 10 times using Delayed Sweep. The DELAY-TIME MULTIPLIER dial has been adjusted so the delayed sweep starts just before the area of interest.

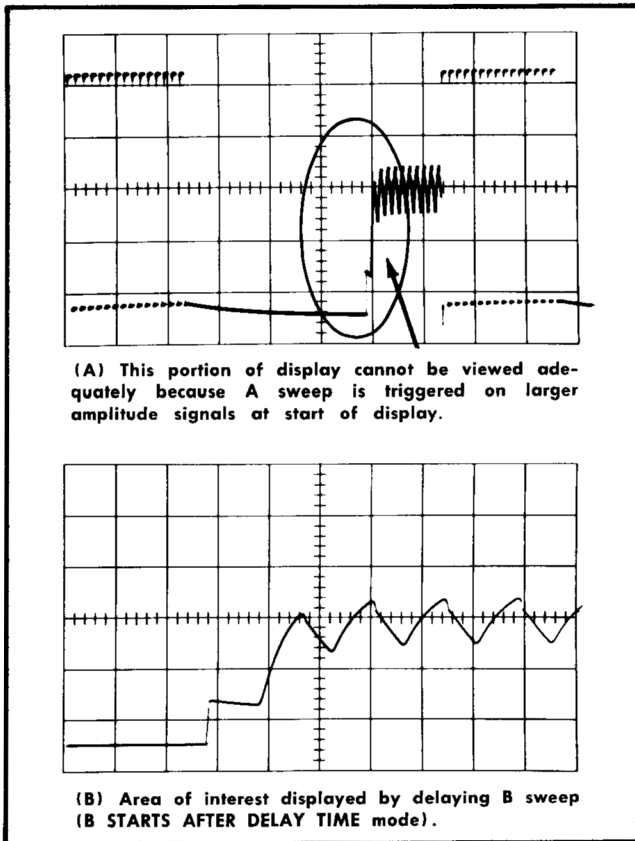

Fig. 2-26. Displaying a complex signal using delayed sweep.

Pulse Jitter Measurements

In some applications it is necessary to measure the amount of jitter on the leading edge of a pulse or jitter between pulses.

Use the following procedure:

1. Connect the signal to either INPUT connector. Set the MODE switch to display the channel used.
2. Set the VOLTS/DIV switch to display about four divisions of the waveform.
3. Set the A TIME/DIV switch to a sweep rate which displays the complete waveform.
4. Set the A Triggering controls to obtain as stable a display as possible.
5. Set the HORIZ DISPLAY switch to A INTEN DURING B and the B SWEEP MODE switch to B STARTS AFTER DELAY TIME.
6. Position the start of the intensified portion with the DELAY-TIME MULTIPLIER dial so the pulse to be measured is intensified.
7. Set the B TIME/DIV switch to a setting that intensifies the full portion of the pulse which shows jitter.
8. Set the B SWEEP MODE switch to TRIGGERABLE AFTER DELAY TIME.

9. Adjust the B LEVEL control so the intensified portion is as stable as possible.

10. Set the HORIZ DISPLAY switch to B (DELAYED SWEEP). Slight readjustment of the B LEVEL control may be necessary to produce as stable a display as possible.

11. Pulse jitter is shown by horizontal movement of the pulse (take into account inherent jitter of Delayed Sweep). Measure the amount of horizontal movement. Be sure both VARIABLE controls are set to CAL.

12. Multiply the distance measured in step 11 by the B TIME/DIV switch setting to obtain pulse jitter in time.

Example. Assume that the horizontal movement is 0.5 divisions (see Fig. 2-27), and the B TIME/DIV switch setting is 0.5 μ s.

Using the formula:

$$\text{Pulse Jitter} = \frac{\text{horizontal jitter (divisions)}}{\text{B TIME/DIV setting}} \times \text{B TIME/DIV setting}$$

Substituting the given values:

$$\text{Pulse Jitter} = 0.5 \times 0.5 \mu\text{s}$$

The pulse jitter is 0.25 microseconds.

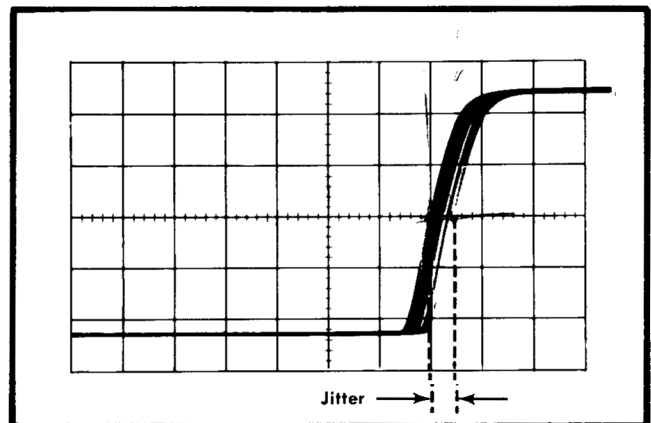

Fig. 2-27. Measuring pulse jitter.

Delayed Trigger Generator

The B + GATE output signal can be used to trigger an external device at a selected delay time after the start of A Sweep. The delay time of the B + GATE output signal can be selected by the setting of the DELAY-TIME MULTIPLIER dial and A TIME/DIV switch.

A Sweep Triggered Internally. When A sweep is triggered internally to produce a normal display, the delayed trigger may be obtained as follows.

1. Obtain a triggered display in the normal manner.
2. Set the HORIZ DISPLAY switch to A INTEN DURING B.

3. Select the amount of delay from the start of A Sweep with the DELAY-TIME MULTIPLIER dial. Delay time can be calculated in the normal manner.

4. Set the B SWEEP MODE switch to B STARTS AFTER DELAY TIME.

5. Connect the B + GATE signal to the external equipment.

6. The duration of the B + GATE signal is determined by the setting of the B TIME/DIV switch.

7. The external equipment will be triggered at the start of the intensified portion if it responds to positive-going triggers, or at the end of the intensified portion if it responds to negative-going triggers.

A Sweep Triggered Externally. This mode of operation can be used to produce a delayed trigger with or without a corresponding display. Connect the external trigger signal to the A EXT TRIG INPUT connector and set the A SOURCE switch to EXT. Follow the operation given above to obtain the delayed trigger.

Normal Trigger Generator

Ordinarily, the signal to be displayed also provides the trigger signal for the oscilloscope. In some instances, it may be desirable to reverse this situation and have the oscilloscope trigger the signal source. This can be done by connecting the A + GATE signal to the input of the signal source. Set the A LEVEL control fully clockwise, A SWEEP MODE switch to AUTO TRIG and adjust the A TIME/DIV switch for the desired display. Since the signal source is triggered by a signal that has a fixed time relationship to the sweep, the output of the signal source can be displayed on the CRT as though the Type 454 were triggered in the normal manner.

Multi-Trace Phase Difference Measurements

Phase comparison between two signals of the same frequency can be made using the dual-trace feature of the Type 454. This method of phase difference measurement can be used up to the frequency limit of the vertical system. To make the comparison, use the following procedure.

1. Set the Input Coupling switches to the same position, depending on the type of coupling desired.

2. Set the MODE switch to either CHOP or ALT. In general, CHOP is more suitable for low-frequency signals and the ALT position is more suitable for high-frequency signals. More information on determining the mode is given under Dual-Trace Operation in this section.

3. Set the TRIGGER switch to CH 1 ONLY.

4. Connect the reference signal to the INPUT CH 1 connector and the comparison signal to the INPUT CH 2 connector. The reference signal should precede the comparison signal in time. Use coaxial cables or probes which have equal time delay to connect the signals to the INPUT connectors.

5. If the signals are of opposite polarity, pull the INVERT switch out to invert the Channel 2 display. (Signals may be

of opposite polarity due to 180° phase difference; if so, take this into account in the final calculation.)

6. Set the CH 1 and CH 2 VOLTS/DIV switches and the CH 1 and CH 2 VARIABLE controls so the displays are equal and about five divisions in amplitude.

7. Set the A Triggering controls to obtain a stable display.

8. Set the A TIME/DIV switch to a sweep rate which displays about one cycle of the waveform.

9. Move the waveforms to the center of the graticule with the CH 1 and CH 2 POSITION controls.

10. Turn the A VARIABLE control until one cycle of the reference signal (Channel 1) occupies exactly eight divisions between the first and ninth graticule lines (see Fig. 2-28). Each division of the graticule represents 45° of the cycle (360° ÷ 8 divisions = 45°/division). The sweep rate can be stated in terms of degrees as 45°/division.

11. Measure the horizontal difference between corresponding points on the waveforms.

12. Multiply the measured distance (in divisions) by 45°/division (sweep rate) to obtain the exact amount of phase difference.

Example. Assume a horizontal difference of 0.6 divisions with a sweep rate of 45°/division as shown in Fig. 2-28.

Using the formula:

$$\text{Phase Difference} = \frac{\text{horizontal difference}}{\text{divisions}} \times \text{sweep rate (degrees/div)}$$

Substituting the given values:

$$\text{Phase Difference} = 0.6 \times 45^\circ$$

The phase difference is 27°.

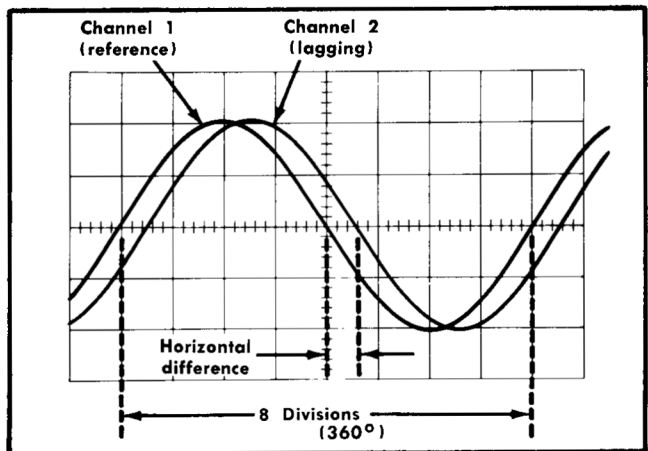

Fig. 2-28. Measuring phase difference.

High Resolution Phase Measurements

More accurate dual-trace phase measurements can be made by increasing the sweep rate (without changing the A VARIABLE control setting). One of the easiest ways to increase the sweep rate is with the MAG switch. Delayed sweep magnification may also be used. The magnified

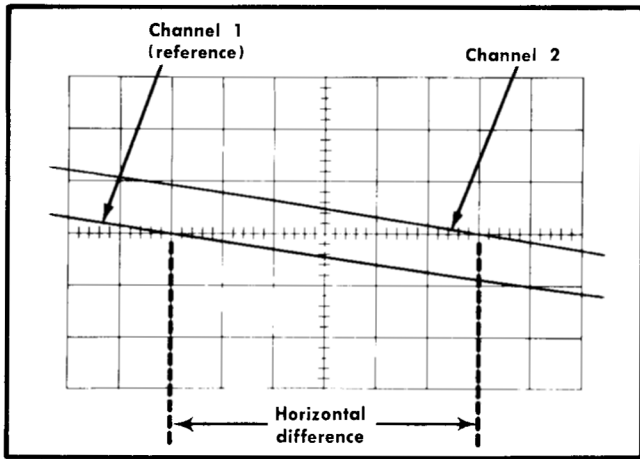

Fig. 2-29. High resolution phase-difference measurement with increased sweep rate.

sweep rate is determined by dividing the sweep rate obtained previously by the amount of sweep magnification.

Example. If the sweep rate were increased 10 times with the magnifier, the magnified sweep rate would be $45^\circ \div 10 = 4.5^\circ/\text{division}$. Fig. 2-29 shows the same signals as used in Fig. 2-28 but with the MAG switch set to $\times 10$. With a horizontal difference of 6 divisions, the phase difference is:

$$\text{Phase Difference} = \frac{\text{horizontal difference}}{\text{divisions}} \times \text{magnified sweep rate (degrees/div)}$$

Substituting the given values:

$$\text{Phase Difference} = 6 \times 4.5^\circ$$

The phase difference is 27° .

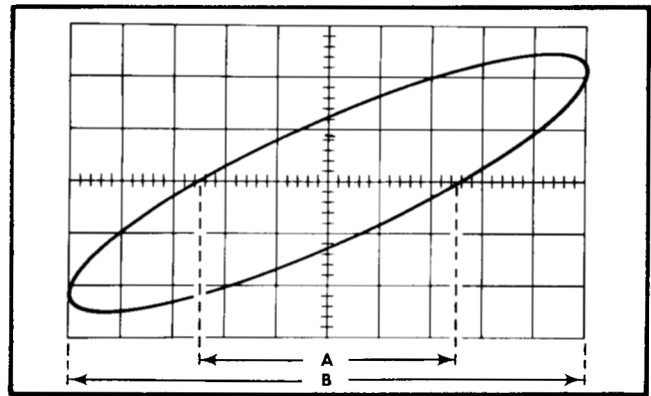

Fig. 2-30. Phase-difference measurement from an X-Y display.

X-Y Phase Measurements

The X-Y phase measurement method can be used to measure the phase difference between two signals of the same frequency. This method provides an alternate method of measurement for signal frequencies up to two megahertz. However, above this frequency the inherent phase difference between the vertical and horizontal systems makes accurate phase measurement difficult. In this mode, one of the sine-wave signals provides horizontal deflection (X) while the other signal provides the vertical deflection (Y). The phase angle between the two signals can be determined from the lissajous pattern as follows.

1. Connect one of the sine-wave signals to the INPUT CH 1 OR X connector and the other signal to the INPUT CH 2 OR Y connector.
2. Set the HORIZ DISPLAY switch to X-Y, MAG switch to OFF and the TRIGGER switch to CH 1 ONLY OR X-Y.

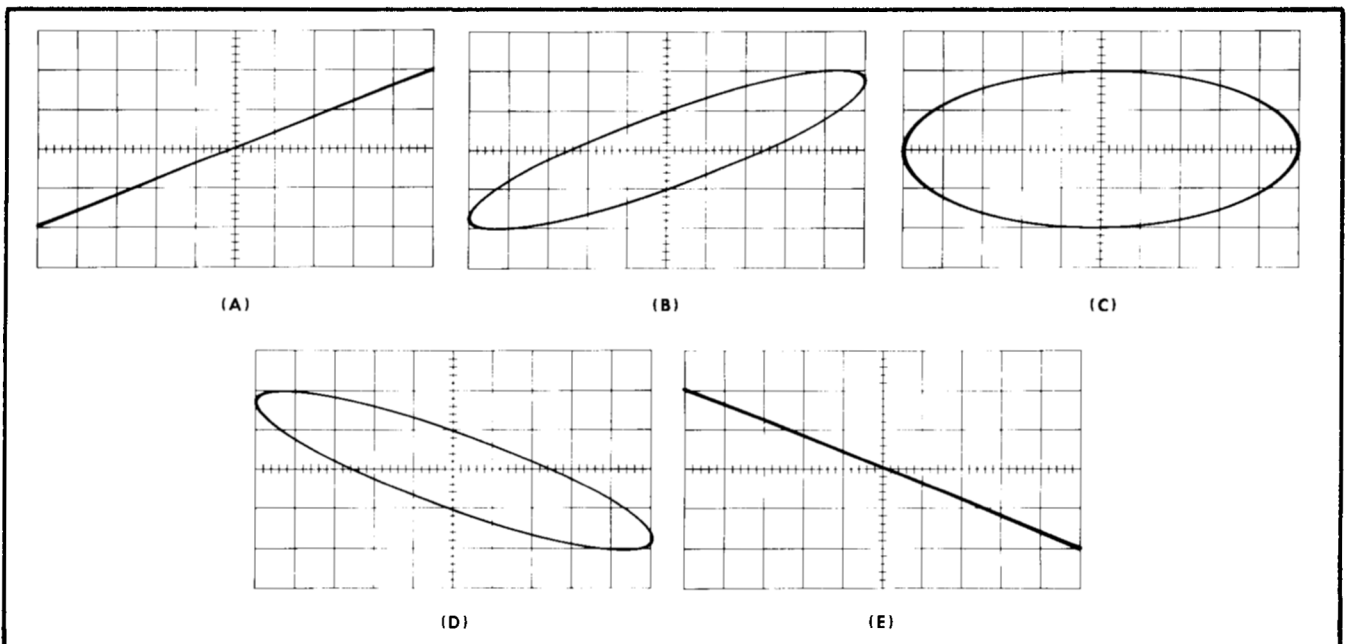

Fig. 2-31. Phase of lissajous displays. (A) 0° or 360° , (B) 30° or 330° , (C) 90° or 270° , (D) 150° or 210° , (E) 180° .

3. Position the display to the center of the screen and adjust the CH 1 and CH 2 VOLTS/DIV switches to produce a display less than six divisions vertically (Y) and less than 10 divisions horizontally (X). The CH 1 VOLTS/DIV switch controls the horizontal deflection (X) and the CH 2 VOLTS/DIV switch controls the vertical deflection (Y).

4. Center the display in relation to the center graticule lines. Measure the distances A and B as shown in Fig. 2-30. Distance A is the horizontal measurement between the two points where the trace crosses the center horizontal line. Distance B is the maximum horizontal width of the display.

5. Divide A by B to obtain the sine of the phase angle (ϕ) between the two signals. The angle can then be obtained from a trigonometric table.

6. If the display appears as a diagonal straight line, the two signals are either in phase (tilted upper right to lower left) or 180° out of phase (tilted upper left to lower right). If the display is a circle, the signals are 90° out of phase. Fig. 2-31 shows several lissajous displays between 0° and 360° phase shift. Notice that above 180° phase shift the resultant display is the same as at some lower phase angle.

Example. To measure the phase of the display shown in Fig. 2-30 where A is 5 divisions and B is 10 divisions, use the formula:

$$\text{Sine } \phi = \frac{A}{B}$$

Substituting the given values:

$$\text{Sine } \phi = \frac{5}{10} = 0.5$$

From the trigonometric tables:

$$\phi = 30^\circ$$

Common-Mode Rejection

The ADD feature of the Type 454 can be used to display signals which contain undesirable components. These undesirable components can be eliminated through common-mode rejection. The precautions given under Algebraic Addition should be observed.

1. Connect the signal containing both the desired and undesired information to the INPUT CH 1 connector.

2. Connect a signal similar to the unwanted portion of the Channel 1 signal to the INPUT CH 2 connector. For example, in Fig. 2-28 a line frequency signal is connected to Channel 2 to cancel out the line-frequency component of the Channel 1 signal.

3. Set both Input Coupling switches to DC (AC if DC component of input signal is too large).

4. Set the MODE switch to ALT. Set the VOLTS/DIV switches so the signals are about equal in amplitude.

5. Set the TRIGGER switch to NORM.

6. Set the MODE switch to ADD. Pull the INVERT switch so the common-mode signals are of opposite polarity.

7. Adjust the CH 2 VOLTS/DIV switch and CH 2 VARIABLE control for maximum cancellation of the common-mode signal.

8. The signal which remains should be only the desired portion of the Channel 1 signal. The undesired signal is cancelled out.

Example. An example of this mode of operation is shown in Fig. 2-32. The signal applied to Channel 1 contains unwanted line-frequency components (see Fig. 2-32A). A corresponding line-frequency signal is connected to Channel 2 (see Fig. 2-32B). Fig. 2-32C shows the desired portion of the signal as displayed when common-mode rejection is used.

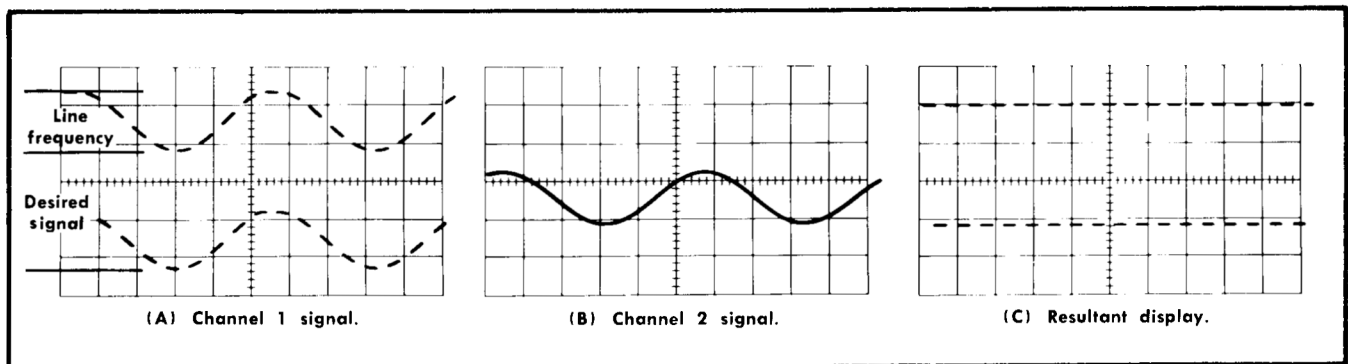

Fig. 2-32. Using the ADD feature for common-mode rejection. (A) Channel 1 signal contains desired information along with line-frequency component, (B) Channel 2 signal contains line-frequency only, (C) CRT display using common-mode rejection.

SECTION 3

CIRCUIT DESCRIPTION

Introduction

This section of the manual contains a description of the circuitry used in the Type 454 Oscilloscope. The description begins with a discussion of the instrument using the basic block diagram shown in Fig. 3-1. Then each circuit is described in detail using a detailed block diagram to show the interconnections between the stages in each major circuit and the relationship of the front-panel controls to the individual stages.

A complete block diagram is located in the Diagrams section at the rear of this manual. This block diagram shows the overall relationship between all of the circuits in this instrument. Complete schematics of each circuit are also given in the Diagrams section. Refer to these diagrams throughout the following circuit description for electrical values and relationship.

BLOCK DIAGRAM

General

The following discussion is provided to aid in understanding the overall concept of the Type 454 before the individual circuits are discussed in detail. A basic block diagram of the Type 454 is shown in Fig. 3-1. Only the basic interconnections between the individual blocks are shown on this diagram. Each block represents a major circuit within the instrument. The number on each block refers to the complete circuit diagram which is located at the rear of this manual.

Signals to be displayed on the CRT are applied to either the INPUT CH 1 OR X and/or the INPUT CH 2 OR Y connector. The input signals are then amplified by the Channel 1 Vertical Preamp and/or the Channel 2 Vertical Preamp circuits. The VOLTS/DIV switch in each Vertical Preamp circuit changes attenuation and/or gain to provide the indicated deflection factor. Each Vertical Preamp circuit also includes separate position, input coupling, gain, variable attenuation and balance controls. A trigger-pickoff stage in the Channel 1 Vertical Preamp circuit supplies a sample of the Channel 1 signal to the Trigger Preamp circuit or the CH 1 OUT connector. The output of both Vertical Preamp circuits is connected to the Vertical Switching circuit. This circuit selects the channel(s) to be displayed. An output signal from this circuit is connected to the Z Axis Amplifier circuit to blank out the between-channel switching transients when in the chopped mode of operation. A trigger-pickoff network at the output of the Vertical Switching circuit provides a sample of the displayed signal(s) to the Trigger Preamp circuit.

The output of the Vertical Switching circuit is connected to the Vertical Output Amplifier through the Delay-Line Driver stage and the Delay Line. The Vertical Output Amplifier cir-

cuit provides the final amplification for the signal before it is applied to the vertical deflection plates of the CRT. This circuit includes the BW-BEAM FINDER switch which limits the vertical bandwidth to about five megahertz in the up position and provides full bandwidth in the FULL position. When pressed down, the vertical deflection (along with the horizontal) is compressed within the viewing area to aid in locating an overscanned or off-screen display.

The Trigger Preamp circuit provides amplification for the internal trigger signal selected by the TRIGGER switch. This internal trigger signal is selected from either the Channel 1 Vertical Preamp circuit or the Vertical Switching circuit. Output from this circuit is connected to the A Trigger Generator circuit, B Trigger Generator circuit and the Horizontal Amplifier circuit (for X-Y mode operation).

The A and B Trigger Generator circuits produce an output pulse which initiates the sweep signal produced by the A or B Sweep Generator circuits. The input signal to the A and B Trigger Generator circuits can be individually selected from the internal trigger signal from the Trigger Preamp circuit, an external signal applied to the EXT TRIG INPUT connector, or a sample of the line voltage applied to the instrument. Each trigger circuit contains level, slope, coupling and source controls.

The A Sweep Generator circuit produces a linear sawtooth output signal when initiated by the A Trigger Generator circuit. The slope of the sawtooth produced by the A Sweep Generator circuit is controlled by the A TIME/DIV switch. The operating mode of the A Sweep Generator circuit is controlled by the A SWEEP MODE switch. In the AUTO TRIG position, the absence of an adequate trigger signal causes the sweep to free run. In the NORM TRIG position, a horizontal sweep is presented only when correctly triggered by an adequate trigger signal. The SINGLE SWEEP position allows one (and only one) sweep to be initiated after the circuit is reset with the RESET button.

The B Sweep Generator circuit is basically the same as the A Sweep Generator circuit. However, this circuit only produces a sawtooth output signal after a delay time determined by the A TIME/DIV switch and the DELAY-TIME MULTIPLIER dial. If the B SWEEP MODE switch is set to the B STARTS AFTER DELAY TIME position, the B Sweep Generator begins to produce the sweep immediately following the selected delay time. If this switch is in the TRIGGERABLE AFTER DELAY TIME position, the B Sweep Generator circuit does not produce a sweep until it receives a trigger pulse from the B Trigger Generator circuit after the selected delay time.

The output of either the A or B Sweep Generator circuit is amplified by the Horizontal Amplifier circuit to produce horizontal deflection for the CRT in all positions of the HORIZ DISPLAY switch except X-Y. Other horizontal deflection signals can be connected to the Horizontal Amplifier by using the X-Y mode of operation. The X signal is connected to the Horizontal Amplifier circuit through the Channel 1 Vertical

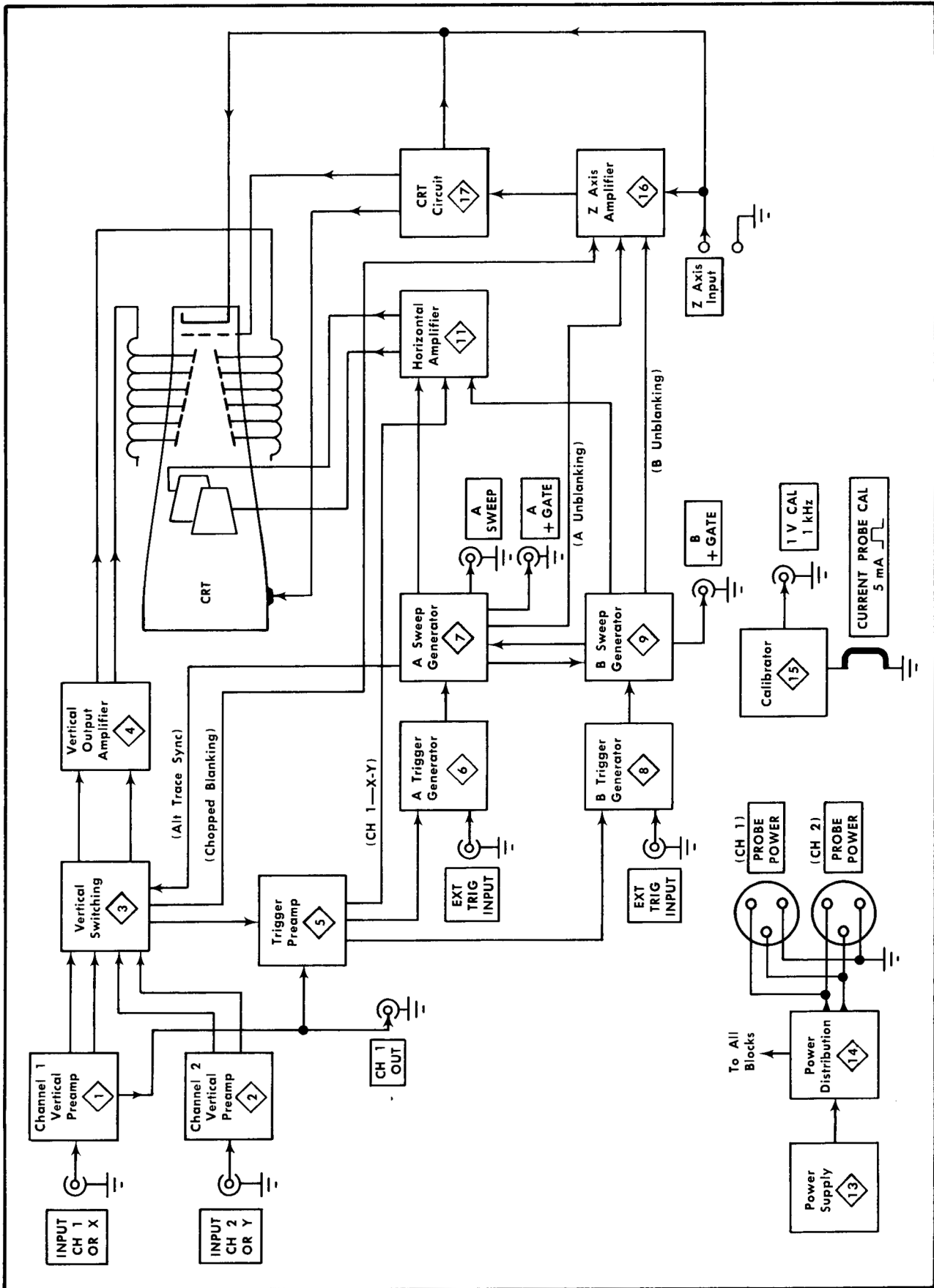

Fig. 3-1. Basic block diagram of the Type 454.

Preamp circuit and the Trigger Preamp circuit when the HORIZ DISPLAY switch is set to X-Y and the TRIGGER switch is set to CH 1 ONLY OR X-Y.

The Z Axis Amplifier circuit determines the CRT intensity and blanking. The Z Axis Amplifier circuit sums the current inputs from the INTENSITY control, Vertical Switching circuit (chopped blanking), A and B Sweep Generator circuit (unblanking) and the external Z AXIS INPUT binding post. The output level of the Z Axis Amplifier circuit controls the trace intensity through the CRT Circuit. The CRT Circuit provides the voltages and contains the controls necessary for operation of the cathode-ray tube.

The Power Supply circuit provides the low-voltage power necessary for operation of this instrument. This voltage is distributed to all of the circuits in the instrument as shown by the Power Distribution circuit. This circuit also provides the voltage levels to the PROBE POWER connectors for the operation of active probe systems. The Calibrator circuit produces a square-wave output with accurate amplitude and frequency which can be used to check the calibration of this instrument and the compensation of probes. The CURRENT PROBE CAL loop provides an accurate current source for calibration of current-measuring probe systems.

CIRCUIT OPERATION

General

The following circuit description is written around the detailed block diagrams which are given for each major circuit. These detailed block diagrams give the names of the individual stages within the major circuits and show how they are connected together. The block diagrams also show the inputs and outputs for each major circuit and the relationship of the front-panel controls to the individual steps. The circuit diagrams from which the detailed block diagrams are derived are shown in the Diagrams section of this manual. The names assigned to the individual stages on the detailed block diagrams are used throughout the following discussion.

This section describes the electrical operation and relationship of the circuits in the Type 454. The theory of operation for circuits which are used only in this instrument are described in detail in this discussion. Circuits which are commonly used in the electronics industry are not described in detail. Instead, references are given to textbooks or other source material which describes the complete operation of these circuits.

CHANNEL 1 VERTICAL PREAMP

General

Input signals for vertical deflection on the CRT can be connected to the INPUT CH 1 OR X connector. In the X-Y mode of operation, this input signal provides the horizontal (X-axis) deflection. The Channel 1 Vertical Preamp circuit provides control of input coupling, vertical deflection factor, balance, vertical position and vertical gain. It also contains a stage to provide a sample of the Channel 1 input signal to the Trigger Preamp circuit for internal triggering from the Channel 1 signal only. Fig. 3-2 shows a detailed block diagram of the Channel 1 Vertical Preamp circuit. A schematic

of this circuit is shown on diagram 1 at the rear of this manual.

Input Coupling

Input signals connected to the INPUT CH 1 OR X connector can be AC-coupled, DC-coupled or internally disconnected. When the Input Coupling switch, SW1, is in the DC position, the input signal is coupled directly to the Input Attenuator stage. In the AC position, the input signal passes through capacitor C1. This capacitor prevents the DC component of the signal from passing to the amplifier. The GND position opens the signal path and connects the input circuit of the amplifier to ground. This provides a ground reference without the need to disconnect the applied signal from the INPUT connector. Resistor R3 connected across the Input Coupling switch, allows C1 to be pre-charged in the GND position so the trace remains on screen when switching to the AC position if the applied signal has a high DC level. C2-R2 reduce the very fast step response overshoot in the AC position of the Input Coupling switch. C4-R4 and C7-R7 provide damping for the attenuator.

Input Attenuator

The $\div 10$ and $\div 100$ Input Attenuators are frequency compensated voltage dividers. For DC and low-frequency signals, they are primarily resistance dividers and the voltage attenuation is determined by the resistance ratio in the attenuator. The reactance of the capacitors in the circuit is so high at low frequencies that their effect is negligible. However, at higher frequencies, the reactance of the capacitors decreases and the attenuator becomes primarily a capacitance voltage divider. Each attenuator contains an adjustable series capacitor to provide optimum response for the high-frequency components of the signal and an adjustable shunt capacitor for optimum response for the lower-frequency components. In addition to providing constant attenuation at all frequencies within the bandwidth, the Input Attenuators are designed to maintain the same input RC characteristics (one megohm \times 20 pF) for each setting of the CH 1 VOLTS/DIV switch.

Input Cathode Follower

The Input Cathode Follower stage, V13, provides a high input impedance with a low impedance drive for the following stage. R8 and R9 in the grid circuit of V13 establish the input resistance of this stage. These resistors are part of the attenuation network at all CH 1 VOLTS/DIV switch positions. Variable capacitor C9 adjusts the basic input time constant for a nominal value of one megohm \times 20 pF. R10 limits the current drive to the grid of V13. Gain of the Input Cathode Follower stage is about 0.8.

B16, D16, D17 and D18 provide protection for the Input Cathode Follower stage. Neon bulb B16 limits the grid swing of V13 to about +70 volts and -55 volts to prevent the grid-to-cathode voltage limit from being exceeded if a high-amplitude signal is applied. Diodes D16, D17 and D18 limit the voltage change at the cathode of V13 to between about +12 volts and -1 volt to prevent damage to the Feedback Amplifier stage. In addition, D17 and D18 clamp the cathode of V13 at about -1 volt during

Circuit Description—Type 454/R454

warm-up time to protect it and the following circuits until the filament reaches normal operating temperature. Diodes D13 and D14 provide a low impedance collector voltage source of about +70 volts for V13. Zener diode D13 drops the +75-volt supply level to about +69 volts and the forward drop of D14 raises this level to about +69.5 volts. R14 provides a continuous current source through zener diode D13 to hold it in the zener region. When V13 is overdriven, D14 is reverse biased and it disconnects the anode level of zener diode D13 from the plate of V13. Then, R13 limits the plate current of V13 to protect the Input Cathode Follower stage.

Transistor Q24 provides a constant current source for V13. The STEP ATTEN BAL adjustment, R21, varies the base level of Q24 to provide a zero-volt level at the emitter of Q34 with no signal applied. With a zero-volt level at the emitter of Q34, the position of a zero-volt reference trace will not change when switching between the various CH 1 VOLTS/DIV positions.

Cathode Attenuator

The $\div 5$ Cathode Attenuator network, C30-D32-R26-R28-R29-R30-R31-R32, reduces the signal at the output of the Input Cathode Follower stage five times in the .1, 1 and 10 positions of the CH 1 VOLTS/DIV switch. The attenuation in this stage along with the attenuation of the Input Attenuator stage and the gain change in the Feedback Amplifier stage provides the correct deflection factor for these switch positions (see Feedback Amplifier discussion). C25 provides high-frequency compensation for the Cathode Attenuator network. The 100 mV Step Atten Bal adjustment R28, and resistor R32 set the quiescent current of D32 to provide the same DC level in the .1, 1 and 10 positions of the CH 1 VOLTS/DIV switch as in the other positions.

Feedback Amplifier

The Feedback Amplifier stage, Q34-Q38-Q44, changes the overall gain of the Channel 1 Vertical Preamp circuit to provide the deflection factors indicated on the front panel.

Approximate gain of this stage is determined by the formula:

$$\text{Voltage Gain, } A = \frac{R47 + R49}{R49} \times 0.9$$

Where 0.9 is the gain of the amplifier configuration with infinite value of R49.

The value of feedback resistor R49 is changed to provide the correct gain for the 5 mV to 50 mV positions of the CH 1 VOLTS/DIV switch. The Input Attenuator and Cathode Attenuator attenuate the signal applied to the Feedback Amplifier in the remaining CH 1 VOLTS/DIV switch positions so the basic gain-switching for the 20 and 50 mV positions provide the remaining deflection factors.

In the 5 mV CH 1 VOLTS/DIV switch position, the input signal is connected directly through the Input Attenuator and Cathode Attenuator to the base of Q34. The CH 1 VOLTS/DIV switch, SW5, connects the network C49A-C49B-R49A-R49B-LR49B into the emitter circuit of Q34. The gain of the Feedback Amplifier stage is about nine in this position to provide a nominal output deflection factor of about 36 millivolts/division (overall circuit gain reduced 0.8 in the Input Cathode Follower stage; see Table 3-1). Variable capacitor C49A and variable resistor R49A provide high-frequency peaking for this network. In the 10 mV position, conditions are the same except that the network C49F-C49G-R49F-R49G is connected into the circuit in place of the previous network. The gain of this stage is now about 4.5 to maintain the same 36 millivolts/division nominal output deflection factor. C49F and R49G provide high-frequency peaking for the network. In the 20 mV position, C49H-C49J-R49H-R49J are connected into the circuit. The gain of the stage is about 2.25 to provide a 36 millivolt nominal output from this stage for each division of CRT deflection. C49H, C49J and R49H provide high-frequency peaking for this network. In the 50 mV position, the emitter network is disconnected. The value of R49 in the formula is infinity and the gain of the stage is about 0.9 (nominal output level remains at 36 millivolts/division). The network C43-C49N-C60-R43-R49N is connected into the collector circuit of Q44 in this position to provide high-frequency damping for the circuit. C49N, C60 and R49N are adjustable to provide optimum high-frequency response.

TABLE 3-1

Vertical Preamp Gain

| VOLTS/DIV Switch Position | Input Attenuator Stage | Input Cathode Follower Stage | Cathode Attenuator Stage | Feedback Amplifier Stage | Overall Gain (approximate) |
|---------------------------|------------------------|------------------------------|--------------------------|--------------------------|----------------------------|
| 5 mV | 1 | 0.8 | 1 | 0.9×10 | 7.2 |
| 10 mV | 1 | 0.8 | 1 | 0.9×5 | 3.6 |
| 20 mV | 1 | 0.8 | 1 | 0.9×2.5 | 1.8 |
| 50 mV | 1 | 0.8 | 1 | 0.9×1 | 0.72 |
| .1 | 1 | 0.8 | 0.2 ($\div 5$) | 0.9×2.5 | 0.36 |
| .2 | 0.1 ($\div 10$) | 0.8 | 1 | 0.9×2.5 | 0.18 |
| .5 | 0.1 ($\div 10$) | 0.8 | 1 | 0.9×1 | 0.072 |
| 1 | 0.1 ($\div 10$) | 0.8 | 0.2 ($\div 5$) | 0.9×2.5 | 0.036 |
| 2 | 0.01 ($\div 100$) | 0.8 | 1 | 0.9×2.5 | 0.018 |
| 5 | 0.01 ($\div 100$) | 0.8 | 1 | 0.9×1 | 0.0072 |
| 10 | 0.01 ($\div 100$) | 0.8 | 0.2 ($\div 5$) | 0.9×2.5 | 0.0036 |

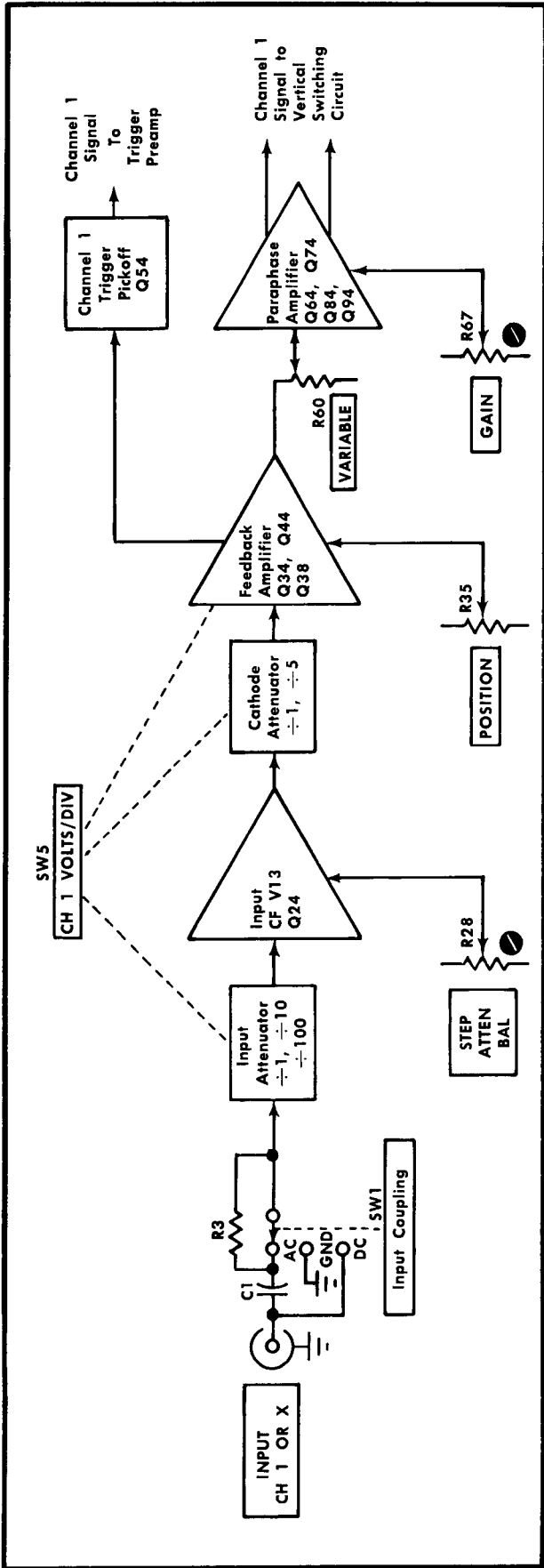

Fig. 3-2. Channel 1 Vertical Preamp detailed block diagram.

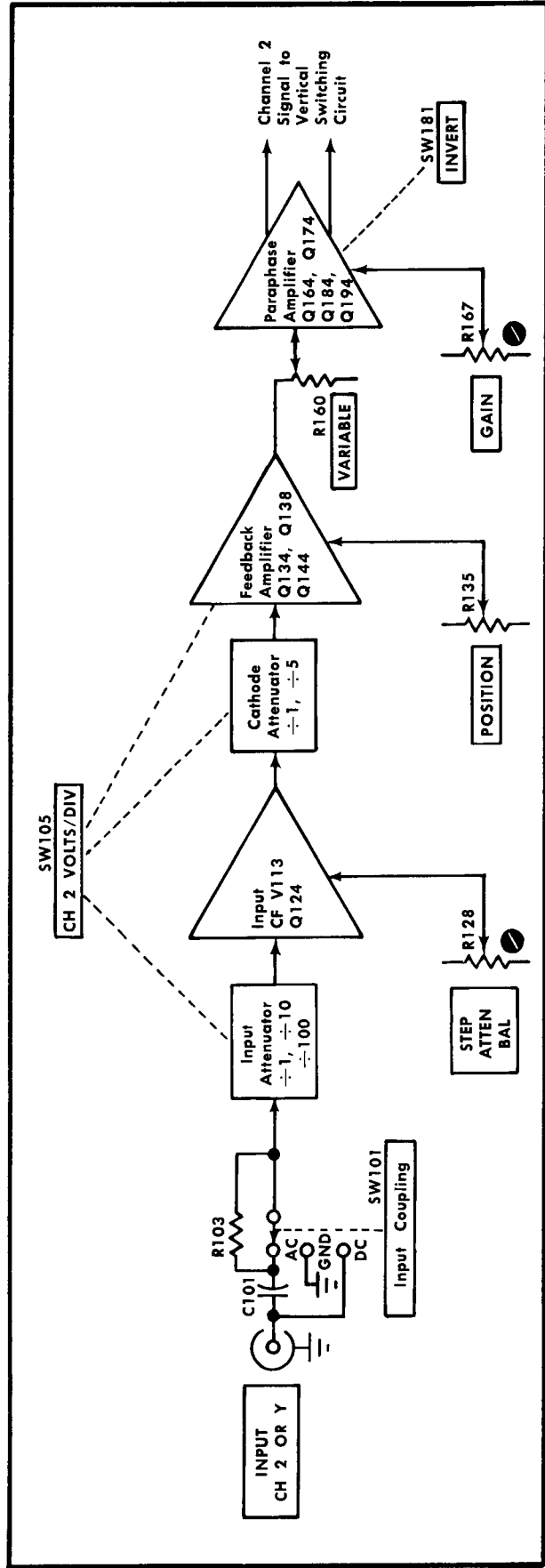

Fig. 3-3. Channel 2 Vertical Preamp detailed block diagram.

Circuit Description—Type 454/R454

To provide higher deflection factors, the input signal is attenuated by the Input Attenuator stage and/or the Cathode Attenuator stage. Table 3-1 shows the gain of the Vertical Preamp circuit through the Input Attenuator, Input Cathode Follower, Cathode Attenuator and Feedback Amplifier stages in each position of the VOLTS/DIV switch. The gain and/or attenuation in each position of the VOLTS/DIV switch maintains the 36 millivolts/division nominal output level from the Feedback Amplifier.

Vertical position of the trace is determined by the setting of the POSITION control, R35. This control changes the base level of Q38, which changes the current drive to Q34. Since the emitter of Q34 is a very low-impedance point in the circuit, there is negligible voltage change at this point. However, the change in current from the POSITION control produces a resultant DC voltage at the output of the Feedback Amplifier stage to change the vertical position of the trace. The CH 1 Position Center adjustment, R40, is adjusted to provide a centered display when the CH 1 POSITION control is centered (with a zero-volt DC input level).

Zener diode D44 provides a low-impedance source for Q44. Variable resistor R44 provides emitter damping for Q44 to prevent high-frequency ringing, and C45 provides high-frequency peaking. Inductor L44 provides a constant DC bias for Q44 while R44 is being adjusted for correct high-frequency response. The output signal from the Feedback Amplifier stage is connected to the Paraphase Amplifier stage and the Channel 1 Trigger Pickoff stage.

Channel 1 Trigger Pickoff

The signal at the collector of Q44 in the Feedback Amplifier stage is connected to the Channel 1 Pickoff stage through D47 and R51. This sample of the Channel 1 signal provides internal triggering from the Channel 1 signal or X-axis deflection for X-Y operation. Q54 is connected as an emitter follower to provide isolation between the Trigger Preamp circuit and the Feedback Amplifier stage. It also provides a minimum load for the Feedback Amplifier stage and a low output impedance to the Trigger Preamp circuit. D47 in the collector circuit of Q44 (Feedback Amplifier) provides thermal compensation for Q54. The CH 1 Output DC Level adjustment, R52, adjusts the DC level at the CH 1 OUT connector for a zero-volt output level when the Channel 1 trace is centered vertically. Output from the Channel 1 Trigger Pickoff stage is connected to the Trigger Preamp circuit through the TRIGGER switch, SW238B.

Paraphase Amplifier

The output signal from the Feedback Amplifier stage is connected to the Paraphase Amplifier stage through the VARIABLE control, R60A-R60B. This control and the T-coil, L64, are designed to provide a constant load for Q44 when the VARIABLE control is rotated. When the VARIABLE control is set to the CAL position (fully clockwise), R60A is by-passed and R60B is set for maximum resistance. Maximum signal current reaches the base of Q64. Switch SW60, ganged with the VARIABLE control, is closed and the UNCAL neon bulb is by-passed. As the VARIABLE control is rotated counterclockwise from the CAL detent, SW60 opens and the UNCAL light, B63, ignites to indicate that the vertical deflection factor is uncalibrated. The signal applied to

the base of Q64 is continuously reduced by R60A as the VARIABLE control is rotated counterclockwise. At the same time that the resistance of R60A increases, the resistance of R60B decreases so the combined resistance of R60A, R60B and R62 remains the same to maintain a constant load for the Feedback Amplifier stage.

Q64 and Q74 are connected as a common-emitter phase inverter (paraphase amplifier)¹ to convert the single-ended input signal to a push-pull output signal. Gain of the stage is determined by the emitter degeneration. As the resistance between the emitters of Q64 and Q74 increases, emitter degeneration increases also to result in less gain through the stage. The GAIN adjustment, R67, varies the resistance between the emitters to control the overall gain of the Channel 1 Vertical Preamp circuit. The network C65-C78-R65-R78 provides emitter peaking for this stage. Capacitor C78 is adjustable to vary the high-frequency gain of this stage to provide optimum high-frequency response.

Transistors Q84 and Q94 provide the output signal from the Channel 1 Vertical Preamp circuit. The signal at the collectors of Q64 and Q74 is connected to the emitters of the grounded-base stage, Q84 and Q94. The output signal on the collectors of Q84 and Q94 is connected to the Channel 1 Diode Gate stage in the Vertical Switching circuit.

CHANNEL 2 VERTICAL PREAMP

General

The Channel 2 Vertical Preamp circuit is basically the same as the Channel 1 Vertical Preamp circuit. Only the differences between the two circuits are described here. Portions of this circuit not described in the following description operate in the same manner as for the Channel 1 Vertical Preamp circuit (corresponding circuit numbers assigned in the 100-199 range). Fig. 3-3 shows a detailed block diagram of the Channel 2 Vertical Preamp circuit. A schematic of this circuit is shown on diagram 2 at the rear of this manual.

Feedback Amplifier

Basically, the Channel 2 Feedback Amplifier operates as described for Channel 1. However, the Channel 2 Vertical Preamp circuit does not have a trigger pickoff stage. To provide a similar load at the collector of Q144 to the load that the Channel 1 Trigger Pickoff stage provides at the collector of Q44, C150 and R150 are connected into the circuit. C150 in this RC network is adjustable to assure similar response in each channel.

Paraphase Amplifier

The basic Channel 2 Paraphase Amplifier configuration and operation is the same as for Channel 1. However, the INVERT switch, SW181, has been added in the Channel 2 circuit. This switch allows the output signal from the Paraphase Amplifier to be connected to either emitter of

¹Lloyd P. Hunter (ed.), "Handbook of Semiconductor Electronics", second edition, McGraw-Hill, New York, pp. 11-94.

the grounded-base output stage, Q184 and Q194. This action allows the displayed signal from Channel 2 to be inverted.

VERTICAL SWITCHING

General

The Vertical Switching circuit determines whether the CH 1 and/or the CH 2 Vertical Preamp output signal is connected to the Vertical Output Amplifier circuit (through the Delay Line Driver and Delay Line stages). In the ALT and CHOP positions of the MODE switch, both channels are alternately displayed on a shared-time basis. Fig. 3-4 shows a detailed block diagram of the Vertical Switching circuit. A schematic of this circuit is shown on diagram 3 at the rear of this manual.

Diode Gate

The Diode Gates, consisting of four diodes each, can be thought of as switches which allow either of the Vertical Preamp output signals to be coupled to the Delay-Line Driver stage. D201 through D204 control the Channel 1 signal output and D206 through D209 control the Channel 2 signal output. These diodes are in turn controlled by the Switching Multivibrator stage for dual-trace displays, or by the MODE switch for single-trace displays.

CH 1. In the CH 1 position of the MODE switch, -12 volts is applied to the junction of D207-D208 in the Channel 2 Diode Gate through the HORIZ DISPLAY switch SW1001A, D238, MODE switch SW238A and R224 (see simplified diagram in Fig. 3-5). This forward biases D207-D208 and reverse biases D206-D209 since the input to the Delay-Line Driver stage is at about -5.8 volts. D206-D209 block the Channel 2 signal so it cannot pass to the Delay-Line Driver stage. At the same time in the Channel 1 Diode Gate, D202-D203 are connected to ground through R210. D202-D203 are held reverse biased while D201-D204 are forward biased. Therefore, the Channel 1 signal can pass to the Delay-Line Driver stage.

CH 2. In the CH 2 position of the MODE switch, the above conditions are reversed. D202-D203 are connected to -12 volts through SW1001A, D238, SW238A and R214, and D207-D208 are connected to ground through R220 (see simplified diagram in Fig. 3-6). The Channel 1 Diode Gate blocks the signal and the Channel 2 Diode Gate allows it to pass.

The HORIZ DISPLAY switch, SW1001A, locks this circuit in the Channel 2 condition when operating in the X-Y mode. This provides -12 volts to reverse bias the Channel 1 Diode gate through R214 and allow the Channel 2 signal to pass to the Delay-Line Driver stage. The cathode of D238 is disconnected so the setting of the MODE switch has no effect on circuit operation in the X-Y mode (also see Horizontal Amplifier discussion).

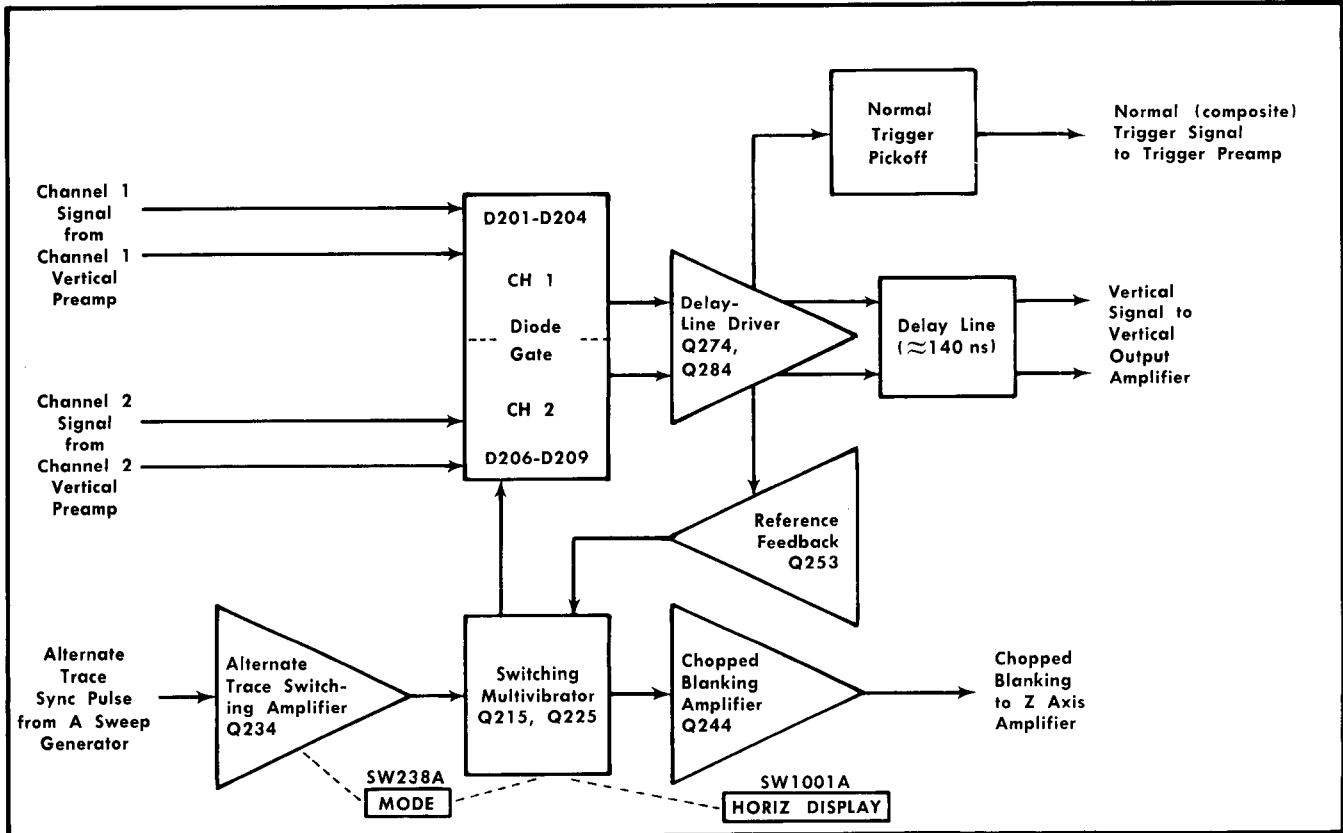

Fig. 3-4. Vertical Switching detailed block diagram.

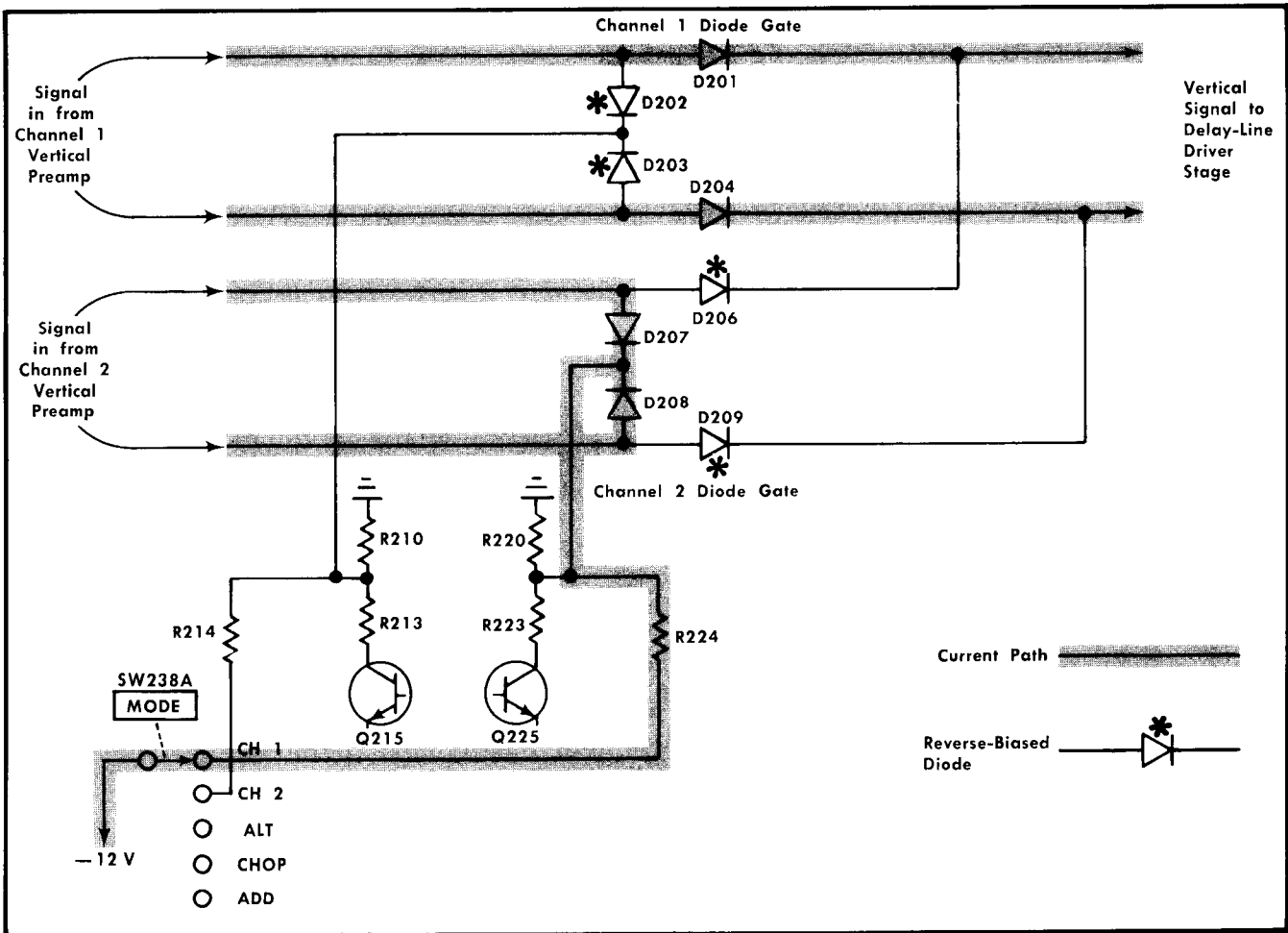

Fig. 3-5. Effect of Diode Gates on signal path (simplified diagram). Conditions shown for CH 1 position of the MODE switch.

Switching Multivibrator

ALT. In this mode of operation, the Switching Multivibrator operates as a bistable multivibrator². In the ALT position of the MODE switch, -12 volts is connected to the emitter of Q234, Alternate Trace Switching Amplifier stage, through SW1001A, D238 and SW238A. Q234 is forward biased to supply current to the 'on' transistor in the Switching Multivibrator stage through R233, R234, D234, and R219 or R229. For example, if Q225 is conducting, current is supplied to Q225 through R229. The current flow through collector resistors R223 and R220 drops the D207-D208 cathode level negative so the Channel 2 Diode Gate is blocked as for Channel 1 only operation. The signal passes through the Channel 1 Diode Gate to the Delay-Line Driver stage.

The alternate-trace sync pulse is applied to Q234 through D237 at the end of each sweep. This negative-going sync pulse momentarily interrupts the current through Q234 and both Q215 and Q225 are turned off. When Q234 turns on again after the alternate-trace sync pulse, the charge on C218 determines whether Q215 or Q225 conducts. For example, when Q225 was conducting, C218 was charged

negatively on the D228 side to the emitter level of Q225, and positively on the D218 side. This charge is stored while Q234 is off and when current flow through Q234 resumes, this stored charge holds the anode of D228 more negative than the anode of D218. D218 is forward biased and the emitter of Q215 is pulled more negative than the emitter of Q225 to switch the multivibrator. The conditions described previously are reversed; now the Channel 1 Diode Gate is reverse biased and the Channel 2 signal passes through the Channel 2 Diode Gate.

The Reference Feedback stage, Q253, provides common-mode voltage feedback from the Delay-Line Driver stage to allow the diode gates to be switched with a minimum amplitude switching signal. The emitter level of Q253 is connected to the junctions of the Switching Multivibrator collector resistors, R210-R213 and R220-R223 through D212 or D222. The collector level of the 'on' Switching Multivibrator transistor is negative and either D212 or D222 is forward biased. This clamps the cathode level of the forward-biased shunt diodes in the applicable Diode Gate about 0.5 volt more negative than the emitter level of Q253. The shunt diodes are clamped near their switching level and therefore they can be switched very fast with a minimum amplitude switching signal. The level at the emitter of Q253 follows the average voltage level at the emitters of the

²Jacob Millman and Herbert Taub, "Pulse, Digital and Switching Waveforms", McGraw-Hill, New York, 1965, pp. 362-389.

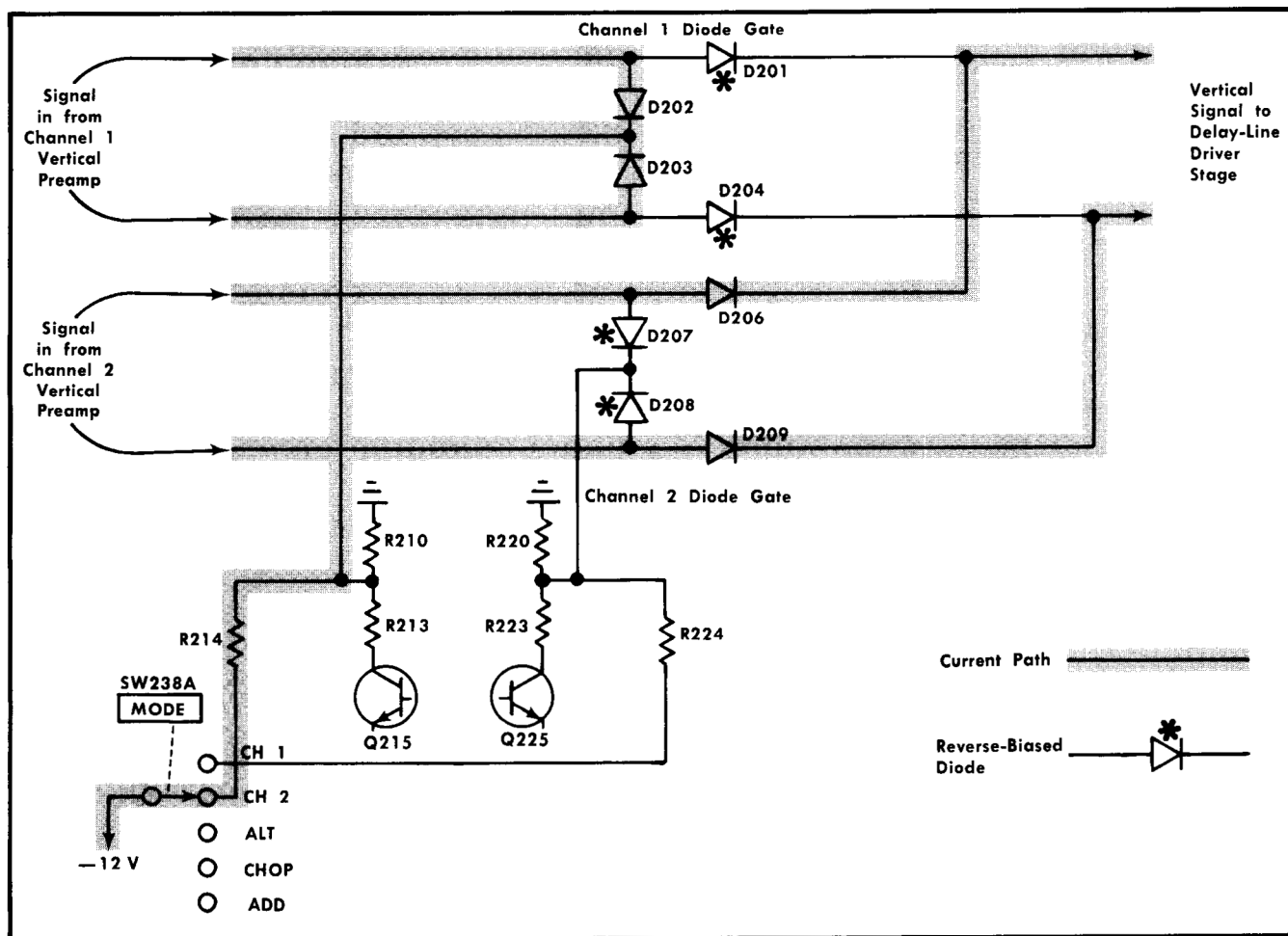

Fig. 3-6. Effect of Diode Gates on signal path (simplified diagram). Conditions shown for CH 2 position of the MODE switch.

Delay-Line Driver stage. This maintains about the same voltage difference across the Diode Gate shunt diodes so they can be switched with a minimum amplitude switching signal regardless of the deflection signal at the anodes of the shunt diodes.

CHOP. In the CHOP position of the MODE switch, the Switching Multivibrator stage free runs as an astable multivibrator³ at about a one-megahertz rate. The emitters of Q215 and Q225 are connected to -12 volts through R219 or R229 and the primary to T240. At the time of turn-on, one of the transistors begins to conduct; for example Q225. Q225 conducts the Channel 2 current and prevents the Channel 2 signal from reaching the Delay-Line Drive stage. Meanwhile, the Channel 1 Diode Gate passes the Channel 1 signal to the Delay-Line Driver stage.

The frequency-determining components in the CHOP mode are C218-R219-R229. Switching action occurs as follows: When Q225 is on, C218 attempts to charge to -12 volts through R219. The emitter of Q215 slowly goes toward -12 volts as C218 charges. The base of Q215 is held at a negative point determined by voltage divider R216-R225 between -12 volts and the collector of Q225. When the

emitter voltage of Q215 reaches a level slightly more negative than its base, Q215 conducts. Its collector level goes negative and pulls the base of Q225 negative through divider R215-R226 to cut Q225 off. This switches the Diode Gate stage to connect the opposite half to the Delay-Line Driver stage. Again C218 begins to charge toward -12 volts, but this time through R229. The emitter of Q225 slowly goes negative as C218 charges, until Q225 turns on. Q215 is shut off and the cycle begins again.

Diodes D218 and D228 are prevented from conducting by D234 and R234, which effectively remove them from the circuit in the CHOP mode. Q253 operates the same in the CHOP mode as in ALT to allow the Diode Gates to be switched with a minimum amplitude switching signal level.

The Chopped Blanking Amplifier stage, Q244, provides an output pulse to the Z Axis Amplifier circuit which blanks out the transitions between the Channel 1 and the Channel 2 trace. When the Switching Multivibrator stage changes states, the voltage across T240 momentarily increases. A negative pulse is applied to the base of Q244 to turn it off. The width of the pulse at the base of Q244 is determined by R241 and C241. Q244 is quickly driven into cut-off and the positive-going output pulse, which is coincident with trace switching, is connected to the Z Axis Amplifier circuit through R245.

³Ibid., pp. 438-451.

Circuit Description—Type 454/R454

ADD. In the ADD position of the MODE switch, the Diode Gate stage allows both signals to pass to the Delay-Line Driver stage. The Diode Gates are both held on by -12 volts applied to their cathodes through R270 and R280. Since both signals are applied to the Delay-Line Driver stage, the output signal is the algebraic sum of the signals on both Channels 1 and 2.

Delay-Line Driver

Output of the Diode Gate stage is applied to the Delay-Line Driver stage, Q274 and Q284. Q274 and Q284 are connected as feedback amplifiers with R276 and R286 providing feedback from the collector to the base of the respective transistor. Output of the Delay-Line Driver stage is connected to the Vertical Output Amplifier through the Delay Line.

Normal Trigger Pickoff

The trigger signal for NORM trigger operation is obtained from the collector of Q274. The Normal Trigger DC Level adjustment, R272, sets the DC level of the normal trigger output signal so the sweep is triggered at the zero-volt level of the displayed signal when the Triggering LEVEL control is set to 0. The normal trigger signal is connected to the Trigger Preamp circuit through SW238B. R283 and R284 in the collector of Q284 provide the same DC load for Q284 as provided to Q274 by the Normal Trigger Pickoff network.

Delay Line

The Delay Line provides approximately 140 nanoseconds delay for the vertical signal to allow the Sweep Generator circuits time to initiate a sweep before the vertical signal reaches the vertical deflection plates. This allows the instrument to display the leading edge of the signal originating the trigger pulse when using internal triggering.

VERTICAL OUTPUT AMPLIFIER

General

The Vertical Output Amplifier circuit provides the final amplification for the vertical deflection signal. The BW-

BEAM FINDER switch provides bandwidth limiting in the up position and compresses an overscanned display within the viewing area in the down position. This amplifier is unique in that many of the components are an integral part of the circuit board. These parts are indicated on the diagram by an asterisk. Fig. 3-7 shows a detailed block diagram of the Vertical Output Amplifier circuit. A schematic of this circuit is shown on diagram 4 at the rear of this manual.

Phase Equalizer Network

The Phase Equalizer Network, C301-C303-C304-C305-L301-L302-L303-L305-L306 and C401-C402-C403-C405-C406-L401-L403-L404-L405 is comprised of three constant resistance, bridged-T phase equalizer sections which compensate the Delay Line by boosting the delay of the very high frequency components of the signal. The variable capacitor C402 is adjusted to obtain an impedance match between the Delay Line and its termination. The major part of the forward-termination resistance for the Delay Line is provided by C307-R307 and C407-R407. The network L308-L408-R308, connected between the emitters of Q314 and Q414, provides a method of thermal compensation whereby Q314-Q414 generate an equal and opposite thermal distortion from that generated by Q374-Q474.

Buffer Amplifier

The Buffer Amplifier stage, Q314 and Q414, provides a low input impedance for the Vertical Output Amplifier circuit to allow accurate Delay Line termination. It also supplies a current drive to the Amplitude Compensation Network.

Amplitude Compensation Network

The Amplitude Compensation Network L318-R318-LR318-LR319-L418-LR418-LR419-R417-R418-R419, connected between the bases of Q324-Q424, provides a gradual boost in gain with increasing frequency to compensate for skin-effect losses in the Delay Line. R417 and R419 are adjustable to provide optimum compensation for the Delay Line losses.

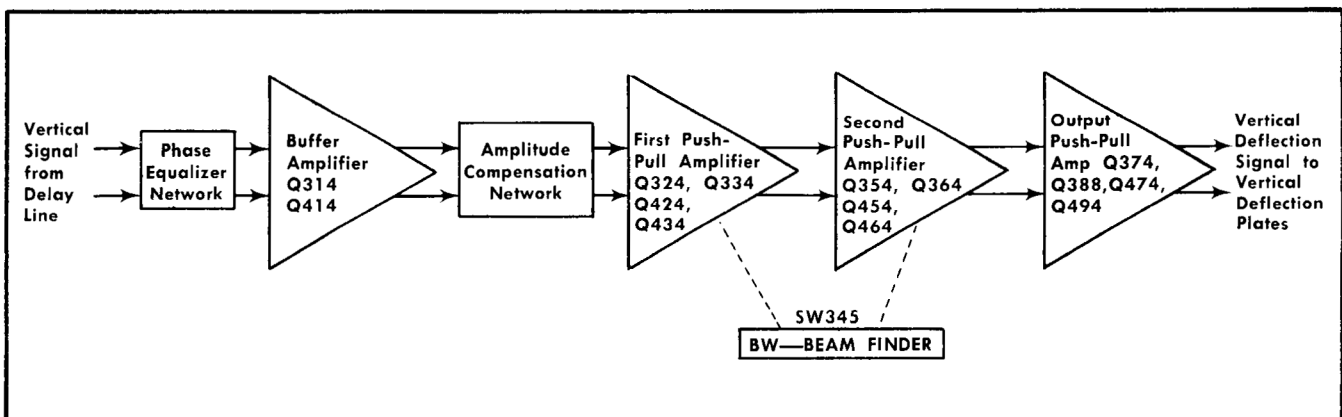

Fig. 3-7. Vertical Output Amplifier detailed block diagram.

Push-Pull Amplifier Stages

General. The 12 transistors following the Buffer Amplifier stage form three similar, four-transistor amplifier stages. Fig. 3-8 shows an equivalent circuit of the basic push-pull amplifier configuration. The current gain (i_{in}/i_{out}) is slightly less than the ratio of R_s to R_e . The configuration used for each of these push-pull amplifier stages provides a higher gain-bandwidth product than a single pair of transistors. The improved response results from the reduction in miller capacitance of the first pair of transistors (common emitter) because of the low input impedance of the second pair of transistors (common base).

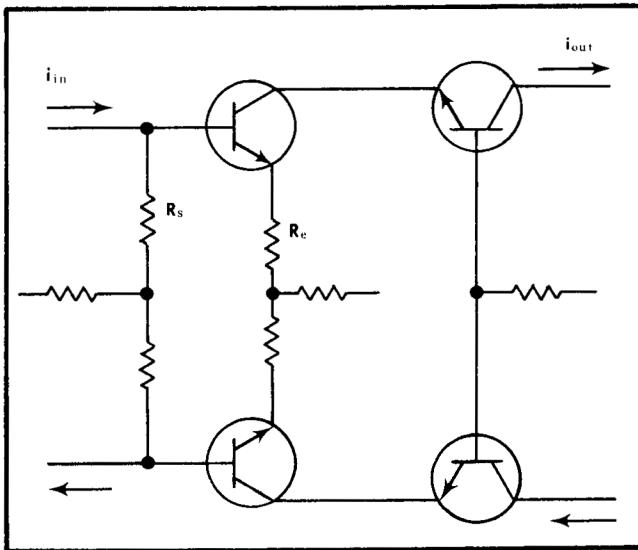

Fig. 3-8. Equivalent circuit of Push-Pull Amplifier stages.

First Push-Pull Amplifier. This stage has less than unity current gain at low frequencies, but the current gain at higher frequencies rises due to the compensating network in the emitter circuit of Q324 and Q424.

The emitter peaking network, C327-R327-C426-R426, compensates for the high-frequency rolloff at the vertical deflection plates due to the termination resistance and the capacitance of the output transistors, Q394 and Q494. C426 and R426 in this network are the high-frequency peaking adjustments for this circuit. Diodes D323-D324-D325-D423-D424-D425 along with thermistor R424 provide thermal compensation to provide bandwidth stabilization. The diodes are held reverse biased and they appear in the circuit as a positive temperature coefficient capacitance. Thermistor R424 has a negative temperature coefficient. R424 and the diodes have a peaking effect which increases with temperature to counteract the opposite tendency of the basic amplifier. The Vertical Position Centering adjustment, R334, adjusts the quiescent DC levels in the Vertical Output Amplifier circuit to provide a centered trace when the inputs of the amplifier are at the same potential (shorted together).

Second Push-Pull Amplifier. The network C337-L336-L337-R335 and C437-L436-L437-R435 in the base circuit of Q354-Q454 provides inductive peaking for the amplifier. Adjustable emitter peaking is provided by C353-R353 for

optimum frequency response. Bandwidth limiting is provided by relay K442A when the BW-BEAM FINDER switch, SW345, is in the 5 MHz position (up). K442A is actuated to connect C335 between the bases of Q354-Q454 and this additional capacitive loading limits the bandwidth of the amplifier to about five megahertz. In the BEAM FINDER position, this switch limits the gain of Q354-Q454 to compress an off-screen display within the graticule area. Normally, the emitter current for Q354-Q454 is supplied through parallel paths, SW345-L343 and R340. When SW345 is in the BEAM FINDER position, the current source through SW345-L343 is interrupted and the only emitter current source for Q354-Q454 is through R340. With current being supplied only through R340, the emitter current of this stage drops to about 15% of the normal value and the display is compressed vertically within the graticule area.

The signal at the collectors of Q354-Q454 is connected to the emitters of Q364-Q464 through C355-R355-R356-R357 and C455-R455-R456-R457. R355 and R455 provide damping for the collectors of Q354-Q454. Transformer T358 reduces the common-mode signal components in the push-pull signal applied to the following stages.

Output Push-Pull Amplifier. The collector signal from Q364-Q464 is connected to the input of the first transistor pair of the Output Push-Pull Amplifier through C368-D363-L368 and C468-L468-D463. Zener diodes D363 and D463 provide the correct DC voltage match between Q364-Q374 and Q464-Q474 with a minimum of signal attenuation. C368-L368 and C468-L468 provide a constant load for Q364-Q464. The Vertical Gain adjustment, R365, varies the source resistance of Q374-Q474 to set the gain of the Vertical Output Amplifier circuit. C373 and thermistor R373 provide emitter peaking and temperature compensation for bandwidth stabilization. Emitter follower Q388 and variable resistor R382 set the base voltage level of Q394-Q494 which in turn sets the collector voltage level of Q374-Q474. Zener diode D388 (above SN B17000 only) protects Q394-Q494 if Q388 should fail by clamping their bases at about +13.5 volts.

The output signal is connected to the vertical deflection plates of the CRT through the buffer transistors Q394-Q494. A distributed deflection plate system⁴ is used in this instrument for maximum frequency response and sensitivity. The deflection signal from the Vertical Output Amplifier is connected to the integral inductors in the CRT, adjustable inductors L394-L494 and the terminating network C394-R394-R397 and C494-R494-R497. As the signal passes through the integral inductors in the CRT, its velocity is essentially the same as the velocity of the electron beam passing between the vertical deflection plates. This synchronism of the deflection signal and the electron beam reduces the loss in high frequency sensitivity due to electron transit time through the deflection plates. Inductors L394-L494 and resistors R394-R494 are adjusted to minimize signal reflections by providing the correct termination for the vertical deflection plate structure.

TRIGGER PREAMP

General

The Trigger Preamp circuit amplifies the internal trigger signal to the level necessary to drive the A and B Trigger

⁴I. A. D. Lewis and F. H. Wells, "Millimicrosecond Pulse Techniques", second edition, Pergamon Press, New York, 1959, pp. 231-235.

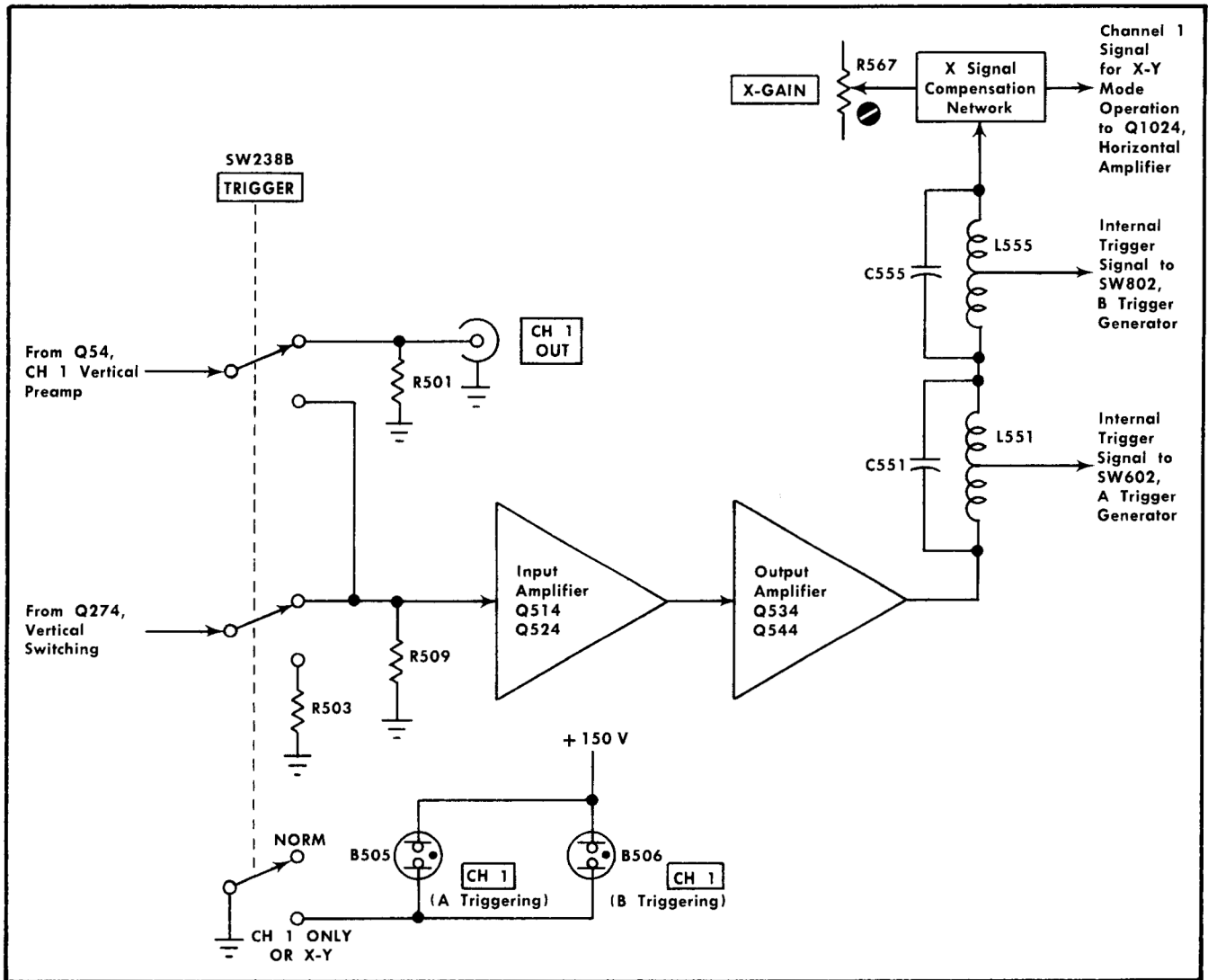

Fig. 3-9. Trigger Preamp detailed block diagram.

Generator circuits. Input signal for the Trigger Preamp circuit is either a sample of the signal applied to Channel 1 or a sample of the composite vertical signal from the Vertical Switching circuit. This circuit also provides a signal to the Horizontal Amplifier for X-Y mode operation. Fig. 3-9 shows a detailed block diagram of the Trigger Preamp circuit. A schematic of this circuit is shown on diagram 5 at the rear of this manual.

Input Amplifier

The internal trigger signal from the Vertical Deflection System is connected to the Trigger Preamp Input Amplifier through the TRIGGER switch, SW238B. When the TRIGGER switch is in the NORM position, the trigger signal is a sample of the composite vertical signal in the Vertical Switching circuit. This signal is obtained from the collector of Q274 and is a sample of the displayed channel (or channels for dual-trace operation). Since the signal source follows the Switching Multivibrator stage, the NORM trigger signal also in-

cludes the chopped switching transients when operating in the CHOP mode. When the TRIGGER switch is in the NORM position, the CH 1 lights, B505 and B506, are disconnected. Also, the sample of the Channel 1 signal is connected to the CH 1 OUT connector. This output signal can be used to monitor Channel 1 or it can be used in cascade with Channel 2 to provide a one millivolt/division, uncalibrated, minimum deflection factor (with reduced bandwidth).

In the CH 1 ONLY OR X-Y position of the TRIGGER switch, the internal trigger signal is obtained from the emitter of Q54 in the Channel 1 Vertical Preamp circuit. Now, the internal trigger signal is a sample of only the signal applied to the INPUT CH 1 connector. The CH 1 lights are turned on to indicate that the TRIGGER switch is in the CH 1 ONLY position and the CH 1 OUT connector is disconnected from the circuit.

R501, R503 and R509 terminate the coaxial cables from the trigger pickoff stages to provide a constant load for these stages. In the NORM position of the TRIGGER switch, the trigger signal from the Vertical Switching circuit is terminated

at the Input Amplifier by R509. The trigger signal from the CH 1 Vertical Preamp circuit is terminated at the CH 1 OUT connector by R501. In the CH 1 ONLY OR X-Y position, the trigger signal from the Channel 1 Vertical Preamp circuit is terminated at the Input Amplifier by R509 and the Vertical Switching circuit signal is terminated by R503.

The internal trigger signal selected by the TRIGGER switch is connected to the Input Amplifier stage, Q514 and Q524. D516 in the emitter circuit of Q514 provides temperature compensation for this stage. Divider R514-R515 establishes a bias on D516 which holds it in conduction throughout the dynamic range of the amplifier to insure that the emitter gain-setting resistor, R515, remains active in the circuit at all times. Zener diode D521 provides a low-impedance source for the emitter of Q524. The signal at the collector of Q514 is connected to the base of Q524 through R517. R518 provides feedback of the output signal at the collector of Q524 to the emitter of Q514. This negative feedback provides consistent gain for the stage. The signal at the collector of Q524 is also connected to the Output Amplifier stage through R530. The Trigger Preamp DC Level adjustment, R511, sets the DC level at the collector of Q544 to zero volts when the input DC level for the amplifier is also at zero volts.

Output Amplifier

The Output Amplifier stage is also a feedback amplifier similar to the Input Amplifier stage. The Input signal at the base of Q534 is amplified by Q534 and Q544. R536 and C536 connect the negative feedback from the collector of Q544 to the emitter of Q534. Zener diode D543 provides a low impedance emitter source for Q544. The overall gain through the Input Amplifier and Output Amplifier stages is about 11; the Input Amplifier stage has a gain of about 3.9 and the Output Amplifier stage has a gain of about 2.9.

The load impedance for Q544 is provided by a transmission line distribution system. Two bridged-T transmission line sections pick off the trigger signals for the A and B Trigger Generator circuits. The capacitive load of the Trigger Generator circuits is the center element of each bridged-T section, C551-L551 and C555-L555. The two bridged-T sections are connected together with a 93-ohm coaxial cable to maintain a 93-ohm impedance all along the line.

R561, R563 and R565 provide the termination (about 93 ohms) for the simulated transmission line to minimize reflections and provide maximum frequency response. These resistors also form a voltage divider from the +12-volt supply to ground which, along with the quiescent current of Q544, establishes a quiescent level of about zero volts at the end of the transmission line. With little voltage drop through the simulated transmission line system, the quiescent DC voltage level at the collector of Q544 and the junction of R561-R563-R565 is essentially the same.

X Signal Compensation Network

The X signal for X-Y mode operation is obtained at the termination of the simulated transmission line. The signal is connected through R565, R566 and a coaxial cable to the X-GAIN adjustment on the side-panel of the instrument. The X-GAIN adjustment, R567, provides signal attenuation to calibrate the X-axis deflection to the CH 1 VOLTS/DIV switch deflection factors when operating in the X-Y mode. The signal is then connected to the delay compensation network,

C568-C569-L568-R569. C568-L568-C569 comprise a pi-section filter with a response that approximates a fixed delay. The delay of this network approximates the difference in delay between the X and Y channels (about 110 nanoseconds). The Horizontal Delay Compensation adjustment, R569, is adjusted for minimum phase shift at medium frequencies and L568 is adjusted for minimum phase shift at high frequencies. The resultant display provides accurate X-Y measurements up to about two megahertz; at higher frequencies the inherent phase shift between the X and Y channels may prevent accurate X-Y measurements. This difference in delay between the X and Y channels appears as a phase difference in the X-Y display and it increases rapidly above about two megahertz since the approximation of the delay compensation network is no longer valid. The output of the X Signal Compensation network is connected to the Horizontal Amplifier circuit.

A TRIGGER GENERATOR

General

The A Trigger Generator circuit produces trigger pulses to start the A Sweep Generator circuit. These trigger pulses are derived either from the internal trigger signal from the vertical deflection system, an external signal connected to the EXT TRIG INPUT connector or a sample of the line voltage applied to the instrument. Controls are provided in this circuit to select trigger level, slope, coupling and source. Fig. 3-10 shows a detailed block diagram of the A Trigger Generator circuit. A schematic of this circuit is shown on diagram 6 at the rear of this manual.

Trigger Source

The A SOURCE switch, SW602, selects the source of the A trigger signal. Three trigger sources are available; internal, line and external. A fourth position of the A SOURCE switch provides 10 times attenuation for the external trigger signal.

The Internal trigger signal is obtained from the vertical deflection system through the Trigger Preamp circuit. This signal is a sample of the signal(s) applied to the INPUT CH 1 and/or CH 2 connectors. Further selection of the internal trigger source is provided by the TRIGGER switch to select the internal trigger signal from both channels or from Channel 1 only (see Trigger Preamp discussion for details).

The line trigger signal is obtained from voltage divider R1104-R1105-R1106 in the Power Supply circuit. This sample of the line frequency, about 1.5 volts RMS, is coupled to the A Trigger Generator circuit in the LINE position of the A SOURCE switch. The A COUPLING switch should not be in the LF-REJ position when using this trigger source, as the signal will be blocked by the LF reject circuit.

External trigger signals applied to the A EXT TRIG INPUT connector can be used to trigger the A sweep in the EXT and EXT \div 10 positions of the A SOURCE switch. Input resistance at DC is about one megohm paralleled by about 20 pF in both external positions. However, when the A COUPLING switch is set to the LF REJ, a 100-kilohm resistor, R609, is connected in parallel with the one-megohm input resistor, R615, to provide attenuation of low-frequency signals. This provides an external input resistance of about 91 kilohms in this A COUPLING switch position. In the EXT \div 10 position, a 10 times frequency compensated attenuator is connected into the input circuit.

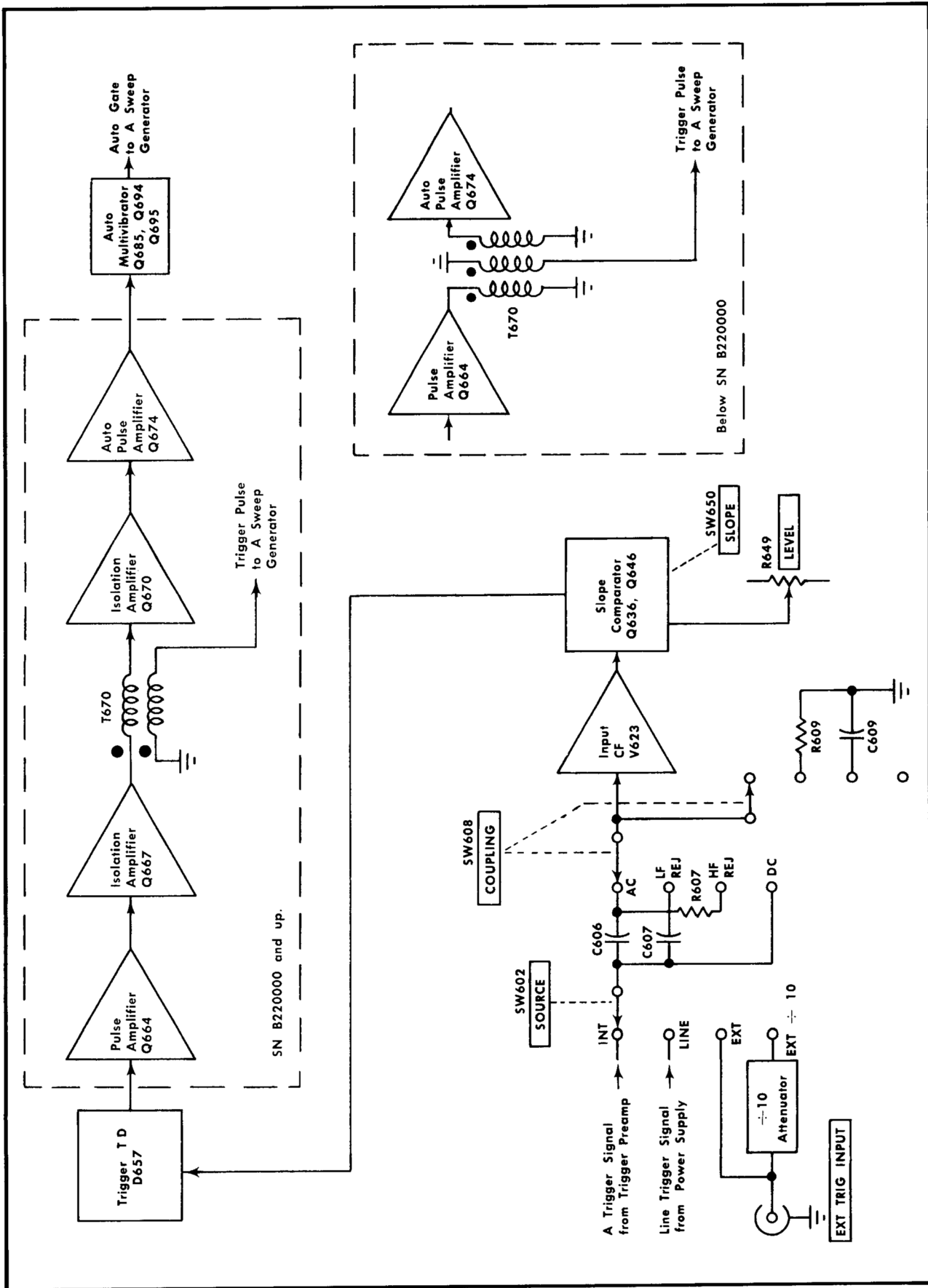

Fig. 3-10. A Trigger Generator detailed block diagram.

This attenuator reduces the input signal amplitude 10 times to provide more A LEVEL control range while maintaining the one-megohm \times 20 pF input RC characteristics.

Trigger Coupling

The A COUPLING switch, SW608, offers a means of accepting or rejecting certain components of the trigger signal. In the AC and LF REJ positions of the A COUPLING switch, the DC component of the trigger signal is blocked by coupling capacitor C606 or C607. Frequency components below about 60 hertz are attenuated in the AC position and below about 50 kilohertz in the LF REJ position while the higher-frequency components of the trigger signal are passed without attenuation.

High-frequency components of the trigger signal are attenuated in the HF REJ position. The trigger signal is AC coupled to the input, attenuating signals below about 60 hertz and above about 50 kilohertz. The DC position passes all signals from DC to 150 megahertz.

Input Cathode Follower

The Input Cathode Follower, V623, provides a high input impedance for the trigger signal. It also provides isolation between the A Trigger Generator circuit and the trigger signal source. Neon bulb B619 protects V623 if excessive input voltage is applied to the A EXT TRIG INPUT connector. The output signal at the cathode of V623 is connected to the Slope Comparator stage.

Slope Comparator

Q636 and Q646 are connected as a difference amplifier (comparator)⁵ to provide selection of the slope and level at which the sweep is triggered. The reference voltage for the comparator is provided by the A LEVEL control, R649, and the A Trigger Level Center adjustment, R643. The A Trigger Level Center adjustment sets the level at the base of Q646 so the display is correctly triggered when the A LEVEL control is centered. The A LEVEL control varies the base level of Q646 to select the point on the trigger signal where triggering occurs.

Diodes D636-D641 and D638-D642 limit the trigger signal change at the base of Q636 to about two volts more positive and negative than the level at the base of Q646. For example, as the base of Q646 rises positive when the A LEVEL control is turned clockwise, the voltage at the cathode of zener diode D641 rises positive along with the change at the base of Q646, but it remains three volts more positive. Therefore, when the trigger signal level at the base of Q636 rises more than about 3.5 volts more positive than the base of Q646, D636 is forward biased to limit the signal excursion. The action is similar for D638-D642 on negative-going signals. This configuration provides protection for the Slope Comparator stage from high-amplitude trigger signals.

R637 establishes the emitter current of Q636 and Q646. The transistor with the most positive base controls conduction of the comparator. For example, assume that the trigger signal at the cathode of V623 is positive going and

Q636 is forward biased. The increased current through R637 produces a larger voltage drop and the emitters of both Q636 and Q646 go more positive. A more positive voltage at the emitter of Q646 reverse biases this transistor, since its base is held at the voltage set by the A LEVEL control, and its collector current decreases. At the same time, Q636 is forward biased and its collector current increases. (Note: There is a narrow region at the switch-over point where both transistors conduct as a linear amplifier). Notice that the signal currents at the collectors of Q636 and Q646 are opposite in phase. The sweep can be triggered from either the negative-going or positive-going slope of the input trigger signal by producing the trigger pulse from either the signal at the collector of Q646 for — slope operation or the signal at the collector of Q636 for + slope operation. This selection is made by the A SLOPE switch, SW650.

When the A LEVEL control is set to 0 (midrange), the base of Q646 is at about one volt positive. The base-emitter drop of Q646 sets the common emitter level of Q636-Q646 to about +0.3 volts. Since the base of Q636 must be about 0.65 volts more positive than its emitter before it can conduct, the comparator switches around the zero-volt level of the trigger signal (zero-volt level on the trigger signal corresponds to about one volt positive at this point, with correct calibration). As the A LEVEL control is turned clockwise toward +, the voltage at the base of Q646 becomes more positive. This increases the current flow through R637 to produce a more positive voltage on the emitters of both Q636 and Q646. Now the trigger signal must rise more positive before Q636 is biased on. The resultant CRT display starts at a more positive point on the displayed signal. When the A LEVEL control is in the — region, the effect is the opposite to produce a resultant CRT display which starts at a more negative point on the trigger signal.

The slope of the input signal which triggers the A sweep is determined by the A SLOPE switch, SW650. When the A SLOPE switch is set to the — position, the collector of Q636 is connected to the +12-volt supply through D651 and R658. The anode of D652 is grounded and this diode is reverse biased. Now the collector current of Q646 must flow through D655, R656, the parallel combination of D657 and R666-L664, R659 and R658 to the +12-volt supply (see Fig. 3-11). Since the output pulse from the A Trigger Generator circuit is derived from the negative-going portion of the signal applied to the Trigger TD stage, the sweep is triggered on the negative-going slope of the input trigger signal (signal applied to Trigger TD stage is in phase with the input signal for — slope triggering). When the A SLOPE switch is set to +, conditions are reversed (see Fig. 3-12). Q646 is connected to the +12-volt supply through D652 and R658. The anode of D651 is grounded to divert the collector current of Q636 through the Trigger TD stage. The signal applied to the Trigger TD stage is now 180° out of phase with the input trigger signal and the sweep is triggered on the positive-going portion of the input signal.

Trigger TD

The Trigger TD stage shapes the output of the Slope Comparator to provide a trigger pulse with a fast leading edge. Tunnel diode D657⁶ is quiescently biased so it operates in its low-voltage state. The current from one of the transistors

⁵Phillip Cutler, "Semiconductor Circuit Analysis", McGraw-Hill, New York, pp. 365-372.

⁶Millman and Taub, pp. 452-455.

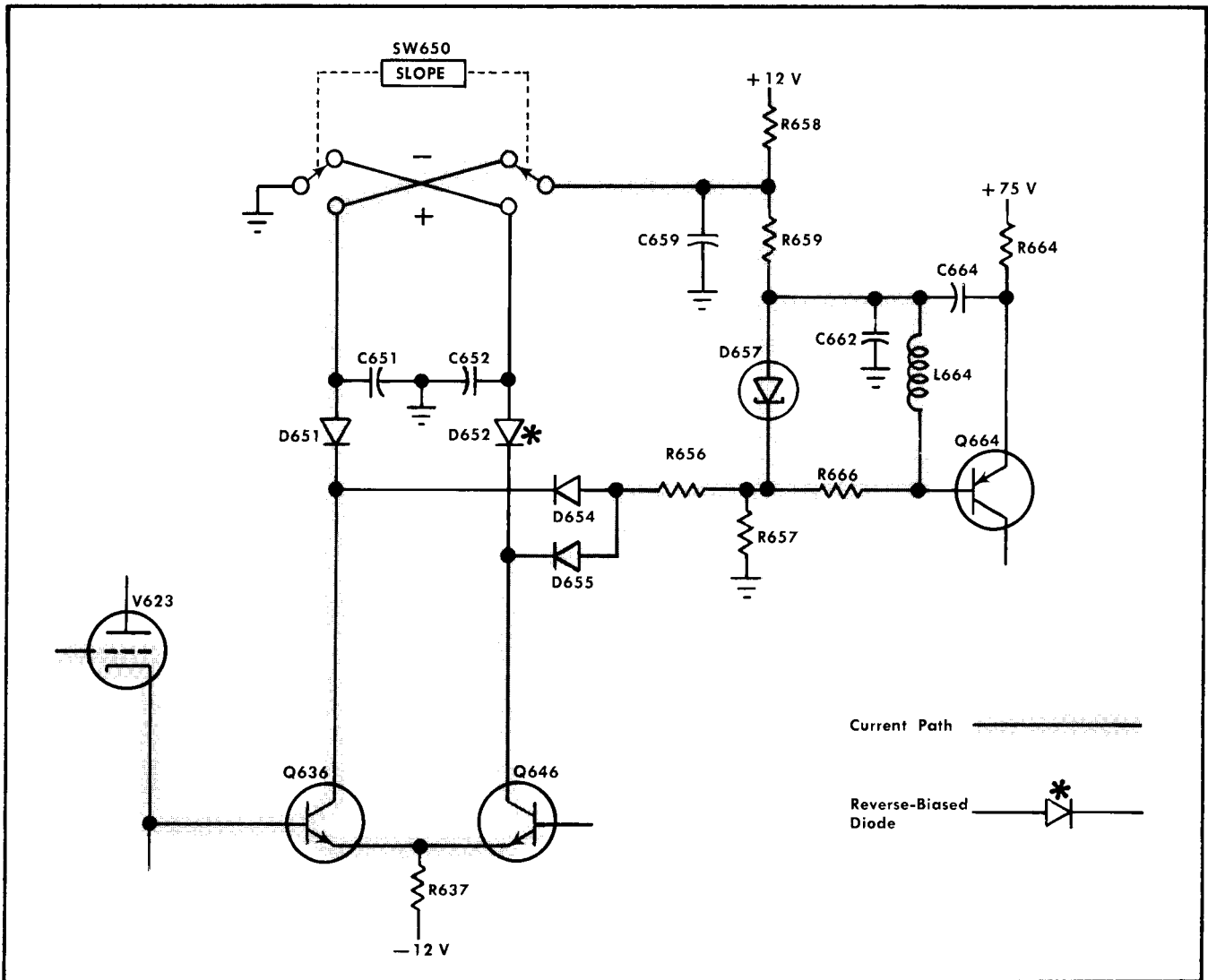

Fig. 3-11. Trigger path for negative-slope triggering (simplified A Trigger Generator diagram).

in the Slope Comparator stage is diverted through the Trigger TD stage by the A SLOPE switch. As this current increases due to a change in the trigger signal, tunnel diode D657 switches to its high-voltage state. L664 opposes this sudden change in current which allows more current to pass through D657 and switch it more quickly. As the current flow stabilizes, L664 again conducts the major part of the current. However, the current through D657 remains high enough to hold it in its high-voltage state. The circuit remains in this condition until the current from the Slope Comparator stage decreases due to a change in the trigger signal applied to the input. Then, the current through D657 decreases and it reverts to its low-voltage state.

Pulse Amplifier

The trigger signal from the Trigger TD stage is connected to the base of the Pulse Amplifier, Q664, through R666 (also C666 and one half of L664 above SN B060000). The trigger pulse at this point is basically a narrow, negative-going pulse with a fast rise.

Pulse and Isolation Amplifiers

Above SN B220000. Q664 is connected as an amplifier with its collector signal DC coupled to the emitter of Isolation Amplifier Q667. The negative-going pulse at the base of Q664 drives it into heavy conduction and the resulting current increase of Q664 flows through R677, Q670, T670, Q667, C664, R569, and R568. Due to the short time constant of the LR network involving R666-L664, the current of Q664 quickly returns to its normal quiescent level. The resultant signal at the collector of Q664 is a positive-going fast-rise pulse.

Q667 and Q670 are isolation amplifier stages that provide drive to the primary of transformer T670 and minimize the effects of unwanted signals being coupled back into the primary from the secondary. Since a transformer responds only to a change in current, the signal in the secondary is a negative-going trigger pulse coincident with the rise of the output signal from the Trigger TD stage. This signal is coupled to the A Sweep Generator circuit through D671. D671 sets the DC voltage level at the output of the secondary

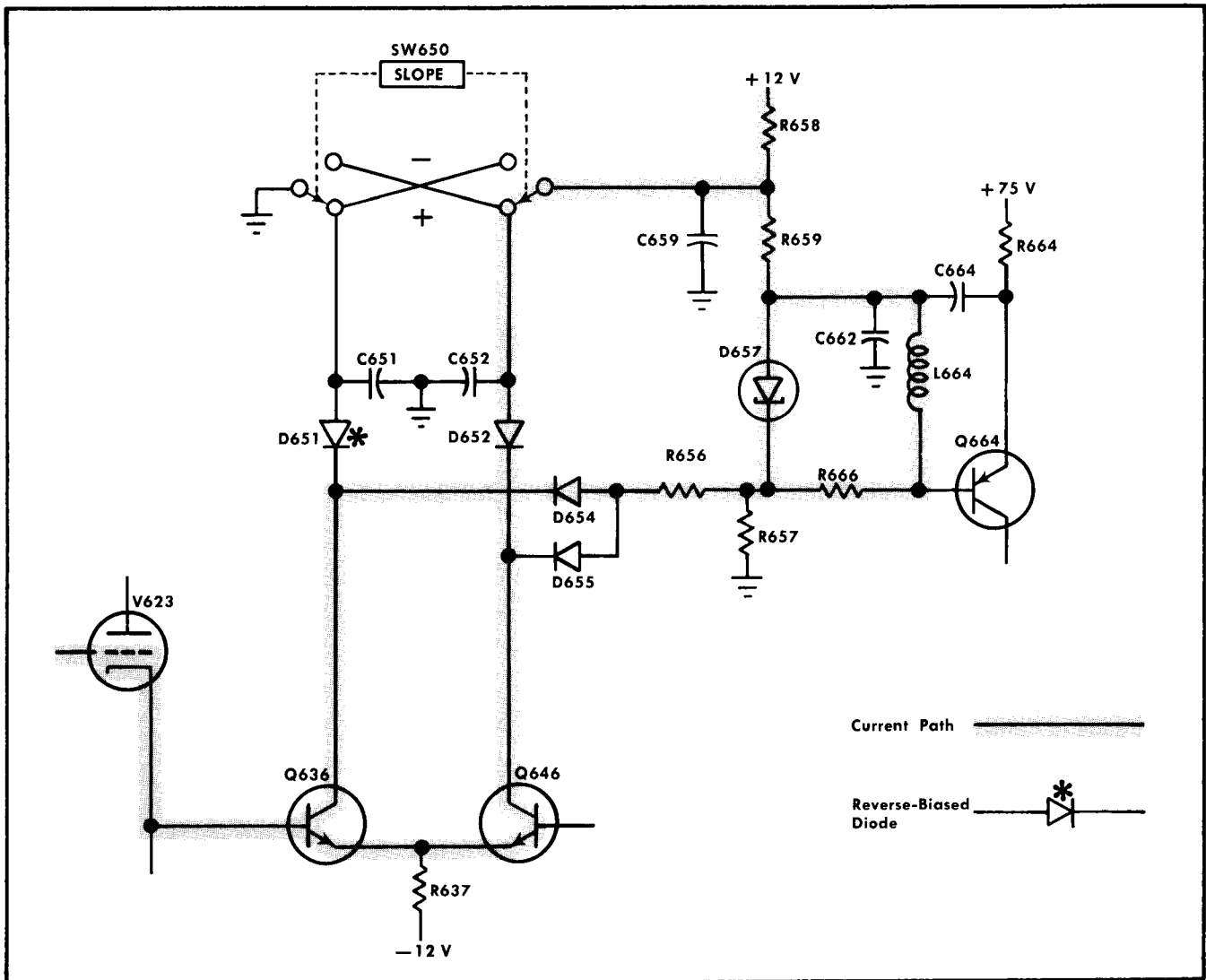

Fig. 3-12. Trigger path for positive-slope triggering (simplified A Trigger Generator diagram).

circuit to about 0.6 volt negative from ground. The collector of Q670 provides a positive-going trigger pulse to the Auto Pulse Amplifier stage.

Below SN B220000. Q664 is connected as an amplifier with the primary of pulse transformer T670 providing the only collector load. The negative-going pulse at the base of Q664 drives it into heavy conduction and the resulting current increase of Q664 flows through T670, C664, R659 and R658. Due to the short time constant of the LR network involving R666-L664, the current of Q664 quickly returns to the level determined by R664 and T670. The resultant signal at the collector of Q664 is a positive-going fast-rise pulse with the width determined by the time constant of the LR network in the circuit. Since a transformer responds only to a change in current, the signals in the secondaries of T670 are positive- and negative-going trigger pulses coincident with the rise of the output signal from the Trigger TD stage. The first of the secondary windings provides a negative-going trigger pulse to the A Sweep Generator circuit through C671. D671 sets the DC voltage level at the output

of this circuit to about 0.6 volt negative from ground. The other secondary winding provides a positive-going pulse to the Auto Pulse Amplifier stage.

Auto Pulse Amplifier

The positive-going trigger pulse from the collector of Q670 is connected to the base of Q674. (Below SN B220000 the signal comes from a secondary winding of T670.) The primary of pulse transformer T680 provides the major collector load for this stage. The positive-going trigger pulse is inverted through Q674 and T680 to produce a positive-going pulse at the base of Q685. D680 blocks any negative-going pulses in the secondary of T680.

Auto Multivibrator

The basic configuration of the Auto Multivibrator stage is a monostable multivibrator⁷ made up of Q685 and Q695. This stage produces the control pulse for the auto-trigger

⁷ibid., pp. 405-438.

Circuit Description—Type 454/R454

circuits located in the A Sweep Generator circuit. Under quiescent conditions (no trigger signal), the base of Q695 is held at about -0.3 volt by voltage divider R696-R697 (LR696 is part of this divider for instruments above SN B070000). The base of Q685 is held at about -0.65 volt by the forward voltage drop of D680. Since the base of Q695 is the most positive, it conducts and raises the emitter level of Q685 positive enough to hold it off. C689 charges to about $+13$ volts through R685 where it is clamped by D687 and D692. The base of Q694 is held at about $+12.6$ volts by D692 which reverse biases it. Since there is no current flow through Q694, its collector level goes negative.

When a trigger signal is present, the positive-going pulses from the Auto Pulse Amplifier stage turn Q685 on. The collector of Q685 goes negative and C689 discharges rapidly through Q685, R699 and R696 (and LR696). As C689 discharges, the current flow through R696 (and LR696) holds Q695 off. When C689 is fully discharged, the current flow through R696 (and LR696) ceases and Q695 comes back on to reset the multivibrator. Now C689 begins to charge towards $+75$ volts through R685. Current also flows through R690 and the base of Q694 goes negative to bias it on. The collector level of Q694 rises positive to produce the auto gate output for the A Sweep Generator circuit.

If the multivibrator does not receive another Trigger Pulse, C689 recharges to about $+13$ volts in about 85 milliseconds. Then Q694 is biased off to end the auto gate (display free runs or is unstable). However, if a repetitive trigger signal turns Q685 on again before C689 has recharged to $+13$ volts, C689 is discharged completely again and once more starts to charge towards $+75$ volts. Since the base of Q694 remains negative enough with a repetitive trigger signal to hold it in condition, the auto gate output level is continuous to produce a triggered display (see Auto Trigger Mode operation in the A Sweep Generator description).

A SWEEP GENERATOR

General

The A Sweep Generator circuit produces a sawtooth voltage which is amplified by the Horizontal Amplifier circuit to provide horizontal sweep deflection on the CRT. This output signal is generated on command (trigger pulse) from the A Trigger Generator circuit. The A Sweep Generator circuit also produces an unblanking gate to unblank the CRT during A sweep time. In addition this circuit produces several control signals for other circuits within this instrument and two output signals to the side-panel connectors. Fig. 3-13 shows a detailed block diagram of the A Sweep Generator circuit. A schematic of this circuit is shown on diagram 7 at the rear of this manual.

The A SWEEP MODE switch allows three modes of operation. In the NORM TRIG position, a sweep is produced only when a trigger pulse is received from the A Trigger Generator circuit. Operation in the AUTO TRIG position is much the same as NORM TRIG except that a free-running trace is displayed when a trigger pulse is not present or when the amplitude of the trigger signal is not adequate. In the SINGLE SWEEP position, operation is also similar to NORM TRIG except that the sweep is not recurrent. The following circuit description is given with the A SWEEP

MODE switch set to NORM TRIG. Differences in operation for the other two modes are discussed later.

Normal Trigger Mode Operation

Sweep Gate. The negative-going trigger pulse generated by the A Trigger Generator circuit is applied to the Sweep Gate stage through D701. Tunnel diode D702 is quiescently biased on in its low-voltage state. When the negative-going trigger pulse is applied to its cathode, the current through D702 increases and it rapidly switches to its high-voltage state, where it remains until reset by the Sweep Reset Multivibrator stage at the end of the sweep. The negative-going level at the cathode of D702 is connected to the base of Q704 through C702 and R702. Q704 is turned on and its collector goes positive. This positive-going step is coupled through C704 and R704 to the Disconnect Amplifier and the Output Signal Amplifier.

Output Signal Amplifier. The positive-going gate pulse from the Sweep Gate stage is applied to the base of Q716. This produces a negative-going signal at the collector of Q716 to provide the A unblanking gate. It is also connected to the Holdoff Driver stage. D715 prevents the signal level at the anode of D717 from going more negative than about -0.5 volt. In all positions of the HORIZ DISPLAY switch SW1001A, except X-Y, current is connected to the anode of D717 through R717. Before the A Sweep Gate stage is switched, this current flows through D717 to the Z Axis Amplifier circuit and the CRT is blanked. When the A Sweep Gate stage switches and the collector of Q716 goes negative, D717 is reverse biased and the current from R717 is shunted by Q716. D717 is reverse biased and the CRT is unblanked to allow the A sweep to be displayed. In the A INTEN DURING B position of SW1001A, additional current is added to the circuit at the cathode of D717 through R719 and R918 (in B Sweep Generator circuit). This additional current reduces the intensity level of the CRT display during A sweep time. Then, when the B Sweep Generator produces an unblanking gate, this current is shunted by the B unblanking gate and a brightened portion is produced on the display which is coincident with the B sweep time.

In the X-Y position of the HORIZ DISPLAY switch, $+12$ volts is connected to the cathode of D717 through R718. This holds D717 reverse biased to block the A unblanking gate. The X-Y intensity level is established by the current through R718, the INTENSITY control setting and the level established by the HORIZ DISPLAY switch in the Z Axis Amplifier circuit (see Z Axis Amplifier discussion).

The positive-going gate signal at the base of Q716 is emitter-coupled to Q726. This positive-going signal at the emitter of Q726 cuts it off and the resulting positive-going signal at its collector is coupled to the Vertical Switching circuit through C728 to provide an alternate-trace sync pulse for dual-trace operation. It is also coupled to the A + GATE output connector on the side panel through R727 to provide a gate signal (about $+12$ volts in amplitude) which is coincident with the A sweep. D726 clamps the collector of Q726 at about -0.5 volts when it is conducting.

Holdoff Driver. The negative-going signal at the collector of Q716 when the sweep begins is connected to the Holdoff Capacitor through Q714. This negative-going signal discharges the Holdoff Capacitor completely at the start

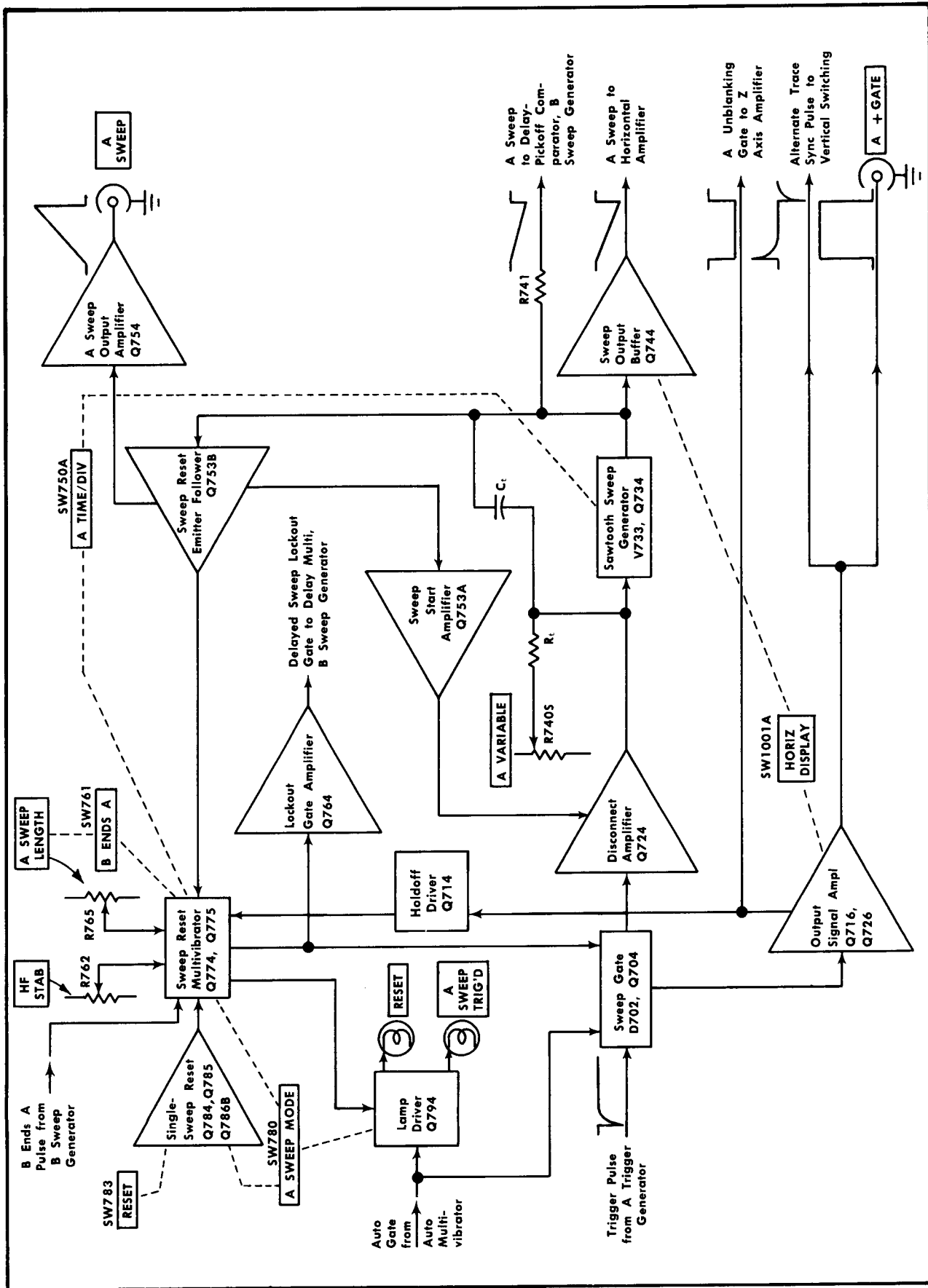

Fig. 3-13. A Sweep Generator detailed block diagram.

Circuit Description—Type 454/R454

of each sweep to provide accurate sweep holdoff time. D710 clamps the collector of Q714 so it does not go more negative than about -0.5 volts.

Disconnect Amplifier. The Disconnect Amplifier, Q724, is quiescently conducting current through R759, the Timing Resistor R740 and the A SWEEP CAL adjustment R743. The positive-going gate signal from Q704 reverse biases Q724 through D707 and the quiescent current flow is interrupted. Now the timing current through the Timing Resistor begins to charge the Timing Capacitor, C740, so the Sawtooth Sweep Generator stage can produce a sawtooth output signal. The positive-going gate signal also reverse biases D759 to disconnect the Sweep Start Amplifier. The Disconnect Amplifier is a fast turn-off transistor to reduce the switching time and improve timing linearity at the start of the sweep.

Sawtooth Sweep Generator. The basic sweep generator circuit is a Miller Integrator circuit.⁸ When the current flow through the Disconnect Amplifier stage is interrupted by the sweep gate signal, the Timing Capacitor, C_T , begins to charge through the Timing Resistor, R_T , and the A Sweep Cal adjustment R743. The Timing Capacitor and Resistor are selected by the A TIME/DIV switch to provide the various sweep rates listed on the front panel. Diagram 10 shows a complete diagram of the A TIME/DIV switch. The A Sweep Cal adjustment allows calibration of this circuit for accurate sweep timing. The A VARIABLE control, R740S (see Timing Switch diagram), provides continuously variable, uncalibrated sweep rates by varying the charge rate of the Timing Capacitor.

As the Timing Capacitor begins to charge positive towards the voltage applied to the Timing Resistor, the grid of V733 rises positive also. This produces a positive-going change at the cathode of V733 which is coupled to the base of Q734 through R735. Q734 amplifies and inverts the voltage change at the cathode of V733 to produce a negative-going sawtooth output. D733 clamps the grid of V733 during warmup time to protect V733 (above SN B110000 only). D735 clamps the base of Q734 at about -0.5 volt to protect Q734 during the warmup of V733. To provide a linear charging rate for the Timing Capacitor, the sweep output signal is connected to the negative side of C740. This feedback provides a constant charging current for C740 which maintains a constant charge rate to produce a linear sawtooth output signal. The output voltage continues to go negative until the circuit is reset through the Sweep Reset Multivibrator. The output signal from the collector of Q734 is connected to the Sweep Output Buffer stage, Q744, through R737 and to the Delay Pickoff Comparator stage in the B Sweep Generator circuit through R741.

Sweep Output Buffer. The Sweep Output Buffer stage, Q744, is a current-driven stage. It provides the output sawtooth current to the Horizontal Amplifier circuit. The HORIZ DISPLAY switch is connected to this stage to control the A sawtooth output in the various horizontal modes of operation. In the A and A INTEN DURING B positions, Q744 operates as described. However, in the B (DELAYED SWEEP) and X-Y positions, -12 volts is connected to the emitter of Q744 through R739. D732 is forward biased to clamp the emitter of Q744 at about -0.5 volt. Q744 is reverse biased and it blocks the A sawtooth output.

Sweep Reset Emitter Follower. The negative-going sawtooth voltage at the collector of Q734 is connected to the base of the Sweep Reset Emitter Follower stage, Q753B, through R749. The negative-going signal at the emitter of Q753B is coupled to the Sweep Reset Multivibrator stage to determine sweep length and to the Sweep Start Amplifier stage to set the starting point for the sweep. It is also connected to the A Sweep Output Amplifier stage to provide a sawtooth output signal. D749 connected to the base of Q753B protects this stage during instrument warmup.

Sweep Start Amplifier. The signal at the emitter of Q753B goes negative along with the applied sawtooth signal. This increases the forward bias on D757B which in turn decreases the forward bias on D757A as the sawtooth goes negative. When the anode of D757A reaches a level about one volt more positive than the level on the base of Q753A, it is reverse biased to interrupt the current flow through Q753A. The circuit remains in this condition until after the sweep retrace is complete. As the voltage at the emitter of Q753B returns to its original DC level at the end of the sweep, D757A is again forward biased and Q753A conducts through D759 to set the quiescent current through Q724. This establishes the correct starting point for the

sweep. D721 clamps the collector of Q753A about 0.5 volt more positive than the base of Q724 when Q753A is off (during sweep and retrace time). This holds the collector of Q753A close to the emitter level of Q724 while Q753A is off so that when it turns on, the voltage swing at the collector of Q753A is small and the response time is short. The Sweep Start adjustment, R956, (in the B Sweep Generator circuit) sets the base voltage level of Q753A. The collector of Q734 is held at this same voltage level by the negative feedback loop Q724-V733-Q734, thereby setting the starting point for the sweep. The level established by the Sweep Start adjustment is also connected to the B Sweep Start Amplifier so the B sweep starts at the same point as the A sweep.

A Sweep Output Amplifier. The negative-going sawtooth signal at the emitter of Q753B is connected to the base of Q754 through R755. Q754 amplifies and inverts this signal to produce a positive-going sweep output signal at the A SWEEP connector on the side panel. D750 protects Q754 if a high-amplitude negative voltage is accidentally applied to the A SWEEP connector.

Sweep Reset Multivibrator. The negative-going sawtooth at the emitter of Q753B is coupled to the cathodes of D760 and D761. These diodes are quiescently reverse biased at the start of the sweep. As the sawtooth voltage at the cathode of D761 goes negative, D761 is forward biased at a level about 0.5 volt more negative than the base level of Q775 (A SWEEP LENGTH control in FULL position). Then the negative-going sawtooth signal from the Sweep Reset Emitter Follower stage is connected to the base of Q775 through R776 (above SN B150000 only). Q774 and Q775 are connected as a Schmitt bistable multivibrator⁹. Quiescently, at the start of the sweep, Q774 is conducting and Q775 is biased off to produce a negative level at its collector. This negative level allows the Sweep Gate tunnel diode, D702, to be switched to produce a sweep as discussed pre-

⁸Ibid., pp. 540-548.

⁹Ibid., pp. 389-394.

viously. When the negative-going sweep signal is connected to the base of Q775 through D761, Q775 is eventually biased on and Q774 is biased off by the emitter coupling between Q774-Q775. The collector of Q775 rises positive and D702 is switched back to its low-voltage state through R701. This turns Q704 and Q716 off, and Q724 and Q726 on to rapidly discharge the Timing Capacitor and produce the retrace portion of the sawtooth signal. The Sawtooth Sweep Generator stage is now ready to produce another sweep as soon as the Sweep Reset Multivibrator stage is reset and another trigger pulse is received.

When Q775 is turned on to end the sweep, it remains in conduction for a period of time to establish a holdoff period and allow all circuits to return to their original conditions before the next sweep is produced. The holdoff time is determined by the charge rate of the Holdoff Capacitor, C760. At the start of the sweep, C760 is completely discharged by the unblanking gate through the Holdoff Driver, Q714. The Holdoff Capacitor is held at this level throughout the sweep time. Then, when Q704 is turned off by Q775, Q716 and Q714 are cut off. C760 begins to charge toward +75 volts through R762 and R763. The positive-going voltage across the Holdoff Capacitor as it charges is connected to the base of Q775 through D763 and D766. When the base of Q775 rises positive enough so it is reverse biased, its collector level drops negative and Q774 comes back into conduction. The bias on the Sweep Gate tunnel diode, D702 returns to a level that allows it to accept the next trigger pulse (D702 is enabled). The Holdoff Capacitor, C760, is changed by the A TIME/DIV switch for the various sweep rates to provide the correct holdoff time. Diagram 10 shows a complete diagram of the A TIME/DIV switch.

As the A SWEEP LENGTH control is rotated counterclockwise from the FULL position, D760 controls the turn-off point of the Sweep Reset Multivibrator at a level determined by the setting of R765. R765 places a more positive level on the anode of D760 than is on the anode of D761 so D761 remains reverse biased. The Sweep Reset Multivibrator is now reset as described for FULL operation at the point where D760 (instead of D761) is forward biased. Since this occurs at a more positive level on the negative-going sawtooth, the displayed sweep is shorter. Thus R765 provides a variable sweep length for the A sweep (from about 11 divisions in the FULL position to about four divisions in the fully clockwise position—not in B ENDS A detent). In the B ENDS A position (fully counterclockwise), a negative-going pulse from the B Sweep Generator circuit is connected to the base of Q775 through D770 at the end of the B sweep time. If the A sweep is still running, this negative-going pulse turns on Q775 to end the A sweep also. Since the A sweep ends immediately following the end of the B sweep, this position provides the maximum repetition rate (brightest trace) for Delayed Sweep mode operation.

The HF STAB control, R762, varies the charging rate of the Holdoff Capacitor to provide a stable display at fast sweep rates. This change in holdoff allows sweep synchronization for less display jitter at the faster sweep rates. This control has little effect at slow sweep rates.

Lockout Gate Amplifier. Q764 is a current switch which is driven by the collector signal of Q775 to produce the delayed sweep lockout gate. This negative-going gate at the collector of Q764 is connected to the Delay Multivibrator stage in the B Sweep Generator circuit to lock the

B Sweep Generator out until the A Sweep Generator hold-off period is complete. D769 sets the emitter voltage of Q764 at about -0.5 volt so Q764 turns on when its base is above zero volts.

Lamp Driver. The auto-gate level from the Auto Multivibrator stage in the A Trigger Generator circuit is connected to the Lamp Driver stage, Q794, through D794 and D795. This gate level is coincident with the trigger pulse generated by the A Trigger Generator circuit and is present only when the instrument is correctly triggered. The positive-going auto-gate level at the base of Q794 drives Q794 into saturation. The collector of Q794 goes negative to about zero volts and the A SWEEP TRIG'D light, B793, comes on. This light remains on as long as the auto-gate level is present. When the auto-gate level goes negative because the instrument is no longer triggered, D793 clamps the base level of Q794 at about -0.5 volt and Q794 is reverse biased. The collector of Q794 rises positive and B793 goes off.

Auto Trigger Mode Operation

Operation of the A Sweep Generator circuit in the AUTO TRIG position of the A SWEEP MODE switch is the same as for the NORM TRIG position just described when a trigger pulse is present. However, when a trigger pulse is not present, a free-running reference trace is produced in the AUTO TRIG mode. This occurs as follows:

The auto-gate level from the Auto Multivibrator stage in the A Trigger Generator circuit is also connected to D796. When the auto-gate level is positive (triggered), the current flowing through D796 and R797 reverse biases D797 and the Sweep Gate tunnel diode, D702, operates as previously described for NORM TRIG operation. However, when the instrument is not triggered, the auto-gate level drops negative and the reduction in current through D796 and R797 allows D797 to become forward biased. Now, when the Sweep Reset Multivibrator stage resets at the end of the holdoff period, the additional current from R797-D797 flows through D702 and is sufficient to automatically switch the Sweep Gate tunnel diode stage back into its high-voltage state. The result is that the A Sweep Generator circuit is automatically retriggered at the end of each holdoff period and a free-running sweep is produced. Since the sweep freeruns at the sweep rate of the A Sweep Generator (as selected by the A TIME/DIV switch), a bright reference trace is produced even at fast sweep rates.

Single Sweep Operation

General. Operation of the A Sweep Generator in the SINGLE SWEEP position of the A SWEEP MODE switch is similar to operation in the other modes. However, after one sweep has been produced, the Sweep Reset Multivibrator stage does not reset. All succeeding trigger pulses are locked out until the RESET button is pressed.

In the SINGLE SWEEP position, the A SWEEP MODE switch disconnects the charging current for the Holdoff Capacitor. Now, Q775 remains on when it is forward biased by the sweep through D760 or D761. With Q775 on, D702 is held in its low-voltage state to lock out the incoming trigger pulses. The circuit remains in this condition until reset by the Single-Sweep Reset stage.

Circuit Description—Type 454/R454

Single-Sweep Reset. The Single-Sweep Reset stage produces a pulse to reset the Sweep Reset Multivibrator stage so another sweep can be produced in the SINGLE SWEEP mode of operation. Quiescently, Q784 is held in conduction by the +12 volts applied to its base through R781. When the RESET button, SW783, is pressed, the voltage at the base of Q784, as determined by voltage divider R781-R782, is near zero volts. Q784 is reverse biased and its collector slowly goes positive toward +12 volts. This positive-going change at the collector of Q784 is coupled to the emitter of Q785 through the network C784-C785-R784-R785. This network prevents noise or extraneous pulses from resetting the sweep. When the positive-going level at the emitter of Q785 reaches about +3 volts (base level of Q785 set by divider R771-R772-R773), it turns on and its collector rises positive to forward bias Q786. The collector of Q786 rapidly goes negative, which forces Q785 to conduct even harder. C787-R787 differentiate this negative-going change at the collector of Q786 and connect the fast negative-going pulse to the base of Q774. Q774 turns on and Q775 turns off to enable the Sweep Gate tunnel diode, D702. Now the A Sweep Generator can be triggered when the next trigger pulse is received.

Lamp Driver. In the SINGLE SWEEP mode, the cathode of D795 is connected to ground to block the incoming auto-gate pulse. The A SWEEP TRIG'D light, B793, is disconnected from the collector of Q794 and the RESET light, B792, is connected into the circuit. The anode of D793 is also disconnected from ground. Now, the condition of Q794 is determined by the Sweep Reset Multivibrator stage. When Q774 is off before the RESET button is pressed, the collector level of Q774 is negative. The current through R794-D793-R791 sets the base level of Q794 negative enough to bias it off. However, when the RESET button is pressed and Q774 turns on, its collector goes positive. This positive level allows the base of Q794 to go positive also and it is biased on. The collector of Q794 goes negative and the RESET light comes on. Q794 and the RESET light remain on until Q774 turns off again at the end of the next sweep.

B TRIGGER GENERATOR

General

The B Trigger Generator circuit is basically the same as the A Trigger Generator circuit. Only the differences between the two circuits are discussed here. Portions of the circuit not described in the following discussion operate in the same manner as for the A Trigger Generator circuit (corresponding circuit numbers are assigned in the 800-899 range). Fig. 3-14 shows a detailed block diagram of the B Trigger Generator circuit. A schematic of this circuit is shown on diagram 8 at the rear of this manual.

Input Cathode Follower

The Input Cathode Follower stage, V823, operates in basically the same manner as described for the A Trigger Generator circuit. However, in the B Trigger Generator circuit, the HORIZ DISPLAY switch, SW1001A, blocks the B Trigger Generator input signal in the modes where B triggering is not desired. In the A and X-Y positions of the HORIZ DISPLAY switch, -12 volts is connected to the cathode of D828 through R829. Since the cathode of D833 is

connected to +12 volts through R833, D833 is reverse biased and it blocks the trigger signal. In the A INTEN DURING B and B (DELAYED SWEEP) positions, a second switch, B SWEEP MODE SW835 determines whether the trigger signal is blocked or passed to the Slope Comparator stage. If the B SWEEP MODE switch is in the B STARTS AFTER DELAY TIME position, the trigger signal is blocked as in the A or X-Y positions. However, the B Sweep Generator circuit free-runs in this position as controlled by another portion of the B SWEEP MODE switch located in the B Sweep Generator circuit. In the TRIGGERABLE AFTER DELAY TIME position, -12 volts is disconnected from the cathode of D828 and connected to the cathode of D833 through R835. D833 is now forward biased and the trigger signal can pass to the Slope Comparator stage to produce the trigger pulse.

Pulse Amplifier

The Pulse Amplifier stage in the B Trigger Generator circuit operates much the same as in the A Trigger Generator circuit. However, since there is no Auto Trigger stage in the B Trigger Generator circuit, there is only one secondary on T870. The output pulse is applied to the B Sweep Generator circuit through C871.

B SWEEP GENERATOR

General

The B Sweep Generator circuit is basically the same as the A Sweep Generator circuit. Only the differences between the two circuits are discussed here. The following circuits operate as described for the A Sweep Generator (corresponding circuit number assigned in the 900-999 range): Sweep Gate (D902, Q904), Disconnect Amplifier (Q924), Sawtooth Sweep Generator (V933, Q934), Sweep Reset Emitter Follower (Q953B) and the Sweep Start Amplifier (Q953A). Fig. 3-15 shows a detailed block diagram of the B Sweep Generator circuit. A schematic of this circuit is shown on diagram 9 at the rear of this manual.

Output Signal Amplifier

Basically, the B Output Signal Amplifier is the same as the corresponding circuit in the A Sweep Generator circuit. In the A and X-Y positions of the HORIZ DISPLAY switch, the B unblanking pulse is blocked since there is no forward bias voltage applied to D918 or D919. In the A INTEN DURING B and the B (DELAYED SWEEP) positions, current is connected to the anodes of D918 and D919 through R918 or R919. When the Sweep Gate stage is in its low-voltage state, this current flows through D919 to the Z Axis Amplifier circuit (through the A Sweep Generator circuit) and the CRT is blanked. When the B Sweep Gate stage switches to its high-voltage state at the start of the B sweep, the collector of Q916 goes negative. This forward biases D918 and the blanking current is diverted from D919 through D918. D919 is reverse biased and the CRT is unblanked to allow the B sweep to be displayed. For A INTEN DURING B operation, the CRT display is partially unblanked during A sweep time and further unblanked during B sweep time; see the A Sweep Generator discussion. In the B (DELAYED SWEEP) position, the A unblanking pulse is blocked (see A Output Signal Amplifier discussion).

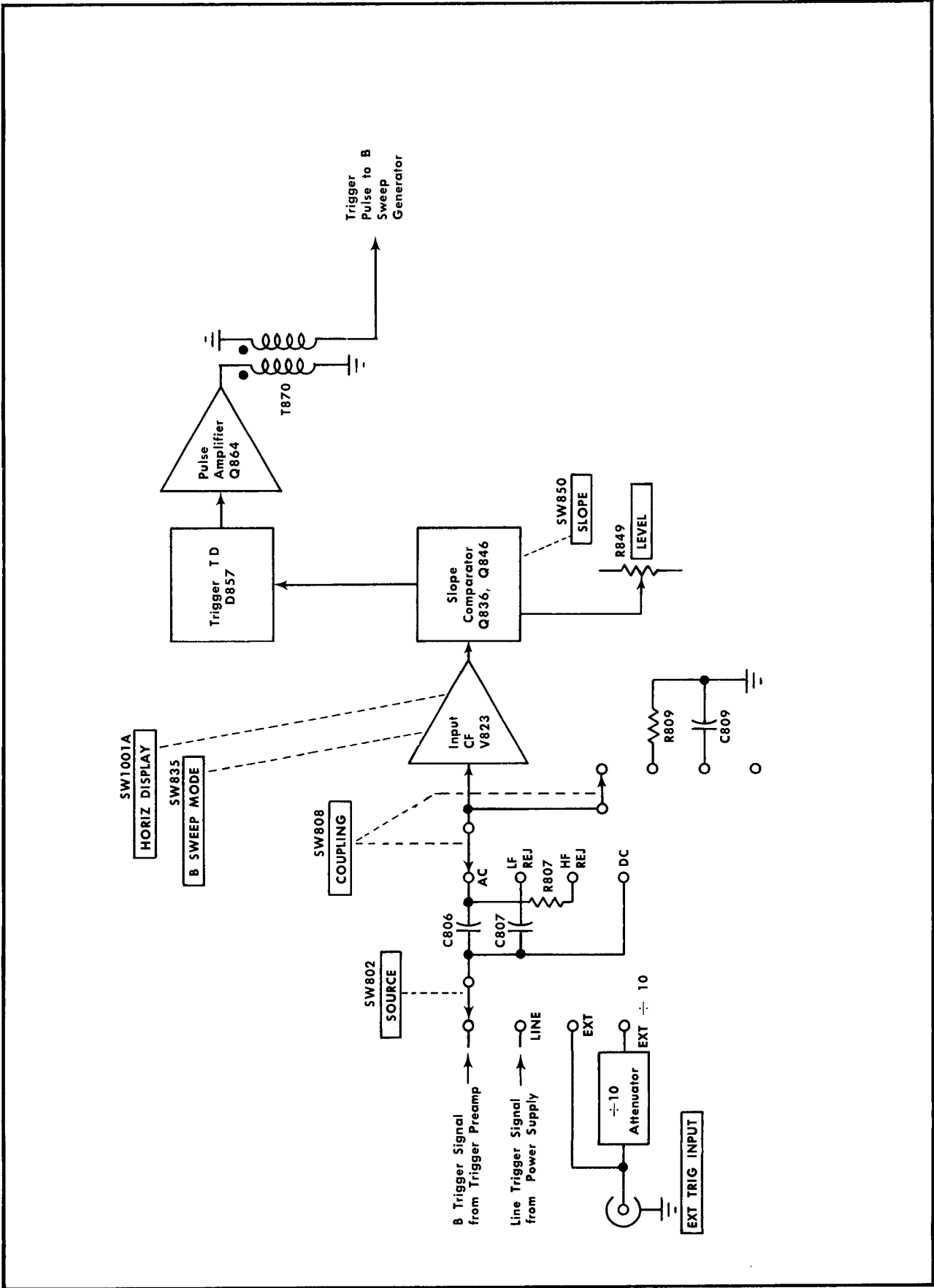

Fig. 3-14. B Trigger Generator detailed block diagram.

Sweep Output Buffer

In the A, A INTEN DURING B and X-Y positions of the HORIZ DISPLAY switch, -12 volts is connected to the emitter of Q944 through R939 to block the B sweep output signal. In the B (DELAYED SWEEP) position, this stage provides the B sweep output sawtooth current to the Horizontal Amplifier circuit. Circuit operation is the same as described for the A Sweep Amplifier stage.

Delay Multivibrator

The Delay Multivibrator, Q985 and Q995, controls the state of the B Sweep Reset Multivibrator. It locks out the B Sweep Generator until it is switched by the Delay Pickoff Comparator. Transistors Q985 and Q995 are connected as a Schmitt bistable multivibrator. Quiescently, Q985 is held on by the negative level at the collector of Q996A and Q995 remains off. The circuit remains in this condition until the incoming A sweep switches the Delay-Pickoff Comparator (see Delay-Pickoff Comparator discussion). Then, the base of Q985 goes positive and it turns off. At the same time, the base of Q995 is pulled negative by the collector level of Q996B and it turns on. The collector of Q985 goes negative and a negative-going output pulse is coupled to the B Sweep Reset Multivibrator stage through C979. This pulse turns Q975 on and Q965 off to enable the B sweep.

The delayed sweep lockout gate from the Lockout Gate Amplifier stage in the A Sweep Generator circuit is connected to the base of Q985 through R987, D988 and D989. This gate goes negative when the A sweep ends and positive after the A sweep holdoff time. Therefore, Q985 is turned on at the end of the A sweep and is held on until after the A sweep holdoff time. However, the base of Q985 remains negative due to the current through Q996A and the B sweep is held locked out until the Delay-Pickoff Comparator stage is switched by the incoming A sweep signal (see Delay-Pickoff Comparator discussion). This configuration allows accurate delayed sweep measurements when the DELAY-TIME MULTIPLIER control is set near 0 by locking out any changes in the quiescent level of the A sawtooth which occur during the A sweep reset and holdoff time. If the B sweep is still running when the A sweep resets, the negative-going portion of the delayed sweep lockout gate connected to Q985 resets the B sweep also.

Delay-Pickoff Comparator

The Delay-Pickoff Comparator stage allows selection of the amount of delay from the start of the A sweep before the B Sweep Generator is turned on. This stage allows the start of B sweep to be delayed between 0.10 and 10.10 times the setting of the A TIME/DIV switch. Then, the B Sweep Generator is turned on and the display is presented at a sweep rate determined by the setting of the B TIME/DIV switch.

Q996A and B are connected as a voltage comparator. In this configuration, the transistor with the most positive base controls conduction. A dual transistor, Q996, and a dual diode, D995, provide temperature stability for the comparator circuit. Q998 maintains a constant current through the conducting transistor. Reference voltage for the comparator circuit is provided by the DELAY-TIME MULTIPLIER control, R996. The voltage to this control is filtered by

R959-C959 to remove transient noise voltages and allow precise delay pickoff. The instrument is calibrated so that the major dial markings of R996 correspond to the major divisions of horizontal deflection on the graticule. For example, if the DELAY-TIME MULTIPLIER dial is set to 5.00, the B Sweep Generator enable pulse is delayed an amount of time equal to five divisions of the A sweep before it can produce a sweep (for this example, B sweep delay time equals five times the setting of the A TIME/DIV switch).

The output sawtooth from the A Sawtooth Sweep Generator stage is connected to the base of Q996A. The quiescent level of the sawtooth biases Q996A on and its collector is negative enough to hold Q985 in the Delay Multivibrator stage in conduction. As the A sweep output sawtooth goes negative, the base of Q996A also goes negative. When it goes more negative than the level at the base of Q996B (established by the DELAY-TIME MULTIPLIER control), Q996B takes over conduction of the comparator and Q996A shuts off. This also switches the Delay Multivibrator stage to produce the desired negative-going reset pulse to the B Sweep Reset Multivibrator. During the A sweep recovery, Q996A is again returned to conduction and Q996B is turned off (Q985 already turned on by delayed sweep lockout gate from A Sweep Generator at the end of the A sweep).

Sweep Reset Multivibrator

The basic B Sweep Reset Multivibrator configuration and operation is the same as for A sweep. However, several differences do exist. B sweep does not have a sweep length network for variable sweep length or a Holdoff Capacitor and associated circuit to reset the B Sweep Reset Multivibrator after the retrace. Instead, the negative-going sweep from the B Sweep Reset Emitter Follower, Q953B, is connected to the base of Q965 through D965. Diode D965 is forward biased when the sweep voltage at the emitter of Q953B drops about 0.5 volt more negative than the level at the base of Q965 established by voltage divider R969-R970 between +12 volts and the collector of Q975. Then Q965 turns on and its collector goes positive to switch the B Sweep Gate tunnel diode, D902, to its low-voltage state which resets the B sweep. Q965 remains on and holds the B Sweep Gate tunnel diode locked out until the B Sweep Reset Multivibrator is reset by the Delay Multivibrator (see previous discussion).

When the B Sweep Reset Multivibrator is reset by the Delay Multivibrator, Q975 comes on and Q965 turns off. The collector of Q965 goes negative and the B Sweep Gate tunnel diode, D902, is enabled. The state in which D902 remains depends upon the B SWEEP MODE switch and the HORIZ DISPLAY switch. When the B SWEEP MODE switch, SW835, is set to the TRIGGERABLE AFTER DELAY TIME position, D902 is biased so it can be switched to its high-voltage state by the next trigger pulse from the B Trigger Generator. However, if the B SWEEP MODE switch is set to the B STARTS AFTER DELAY TIME position, the setting of the HORIZ DISPLAY switch, SW1001A, determines operation of the Sweep Gate tunnel diode. In the A position, the B trigger pulses are blocked in the B Trigger Generator circuit so the B Sweep Generator cannot be triggered and does not produce a sweep (note that the B Sweep Output Buffer, Q944, is also held reverse biased in this position). In the A INTEN DURING B and B (DELAYED SWEEP) positions,

Circuit Description—Type 454/R454

—12 volts is connected to the cathode of D902 through R901, R967 and R968. This voltage pulls the cathode of D902 negative enough so that it automatically switches to its high-voltage state after it is enabled by the B Sweep Reset Multivibrator. This produces a free-running B sweep similar to the no-trigger AUTO TRIG mode in the A Sweep Generator. However, since the B sweep is reset (and automatically retriggered) at a fixed point on the A sweep sawtooth, the display is relatively stable. The best delayed sweep stability is provided in the TRIGGERABLE AFTER DELAY TIME position, however, since the B sweep is initiated by the trigger signal in this mode.

Note that there is no holdoff circuit in the B Sweep Reset Multivibrator stage. The B Sweep Generator circuit is not reset at the end of the B sweep recovery, but is reset after the end of the A sweep by the Delay Multivibrator (see previous discussion).

B Ends A Pulse Amplifier

The positive-going voltage at the collector of Q965 as the B sweep ends is connected to the B Ends A Amplifier, Q964, through R965 and C965. When the A SWEEP LENGTH control is in the B ENDS A position, this pulse saturates Q964 to produce a negative-going pulse at its collector. This negative-going pulse is connected to the A Sweep Reset Multivibrator stage to reset the A sweep at the end of the B sweep for maximum delayed sweep repetition rate.

HORIZONTAL AMPLIFIER

General

The Horizontal Amplifier circuit provides the output signal to the CRT horizontal deflection plates. In all positions of the HORIZ DISPLAY switch except X-Y, the horizontal deflection signal is a sawtooth from either the A Sweep Generator circuit or the B Sweep Generator circuit. In the X-Y position, the horizontal deflection signal is obtained from the Channel 1 Vertical Preamp through the Trigger Preamp circuit. In addition, this circuit contains the horizontal magnifier circuit and the horizontal positioning network. Fig. 3-16 shows a detailed block diagram of the Horizontal Amplifier circuit. A schematic of this circuit is shown on diagram 12 at the rear of this manual.

Input Paraphase Amplifier

The Input Paraphase Amplifier is a current driven stage with a low input impedance. It converts a single-ended input signal to a push-pull output signal which is necessary to drive the horizontal deflection plates of the CRT. In the A and A INTEN DURING B positions of the HORIZ DISPLAY switch, the sawtooth from the A Sweep Generator circuit is connected to the base of Q1014 through R1004. The B sawtooth is blocked by the HORIZ DISPLAY switch in the B Sweep Generator circuit. In the B (DELAYED SWEEP) position of the HORIZ DISPLAY switch, the B sawtooth is connected to Q1014 and the A sawtooth is blocked in the A Sweep Generator circuit. Whichever sawtooth signal is connected to the Horizontal Amplifier produces a current change at the base of Q1014 which is amplified to

produce a positive-going sawtooth voltage at the collector. At the same time, the emitter of Q1014 goes negative and of Q1024 is grounded so that Q1024 operates as the emitter-driven section of a paraphase amplifier. Then, the negative-going change is connected to the emitter of Q1024. In all positions of the HORIZ DISPLAY switch except X-Y, the base going change at its emitter is amplified to produce a negative-going sawtooth signal at the collector. Thus the single-ended input signal has been amplified and is available as a push-pull signal at the collectors of Q1014 and Q1024.

The horizontal POSITION control, R1006A, and FINE control, R1006B, are also connected to the base of Q1014. These controls vary the quiescent DC level at the base of Q1014 which in turn sets the quiescent DC level at the horizontal deflection plates to determine the horizontal position of the trace.

For X-Y operation the HORIZ DISPLAY switch ungrounds the base of Q1024 and connects the base of Q1014 to ground. This allows the Channel 1 signal from the Trigger Preamp circuit to be connected to Q1024 through R1020 (TRIGGER switch set to CH 1 ONLY OR X-Y). The HORIZ DISPLAY switch connects a voltage level to the Vertical Switching circuit also, to lock the Diode Gate stage in the CH 2 mode (see Vertical Switching discussion). Diagram 12 shows a complete diagram of the HORIZ DISPLAY switch. Now, the circuit operates much the same as just described with the sawtooth input. A positive-going signal from Channel 1 produces a current change at the base of Q1024 which increases the current flow through the transistor. The collector of Q1024 goes negative while the emitter-coupled signal to Q1014 produces a positive-going change at the collector of Q1014. Since the base of Q1014 is grounded, the POSITION and FINE controls are disconnected from the input. The DC level of the Channel 1 signal as determined by the CH 1 POSITION control determines the quiescent DC level at the horizontal deflection plates.

Gain Set Push-Pull Amplifier

The push-pull output of the Input Paraphase Amplifier is connected to the bases of Q1034 and Q1044. This stage provides adjustment to set the normal and magnified horizontal gain, and a MAG switch to provide a horizontal sweep which is magnified 10 times. For normal sweep (MAG switch set to OFF), R1036 and R1046 control the emitter degeneration between Q1034 and Q1044 to set the gain of the stage. R1036, Normal Gain, is adjusted to provide calibrated horizontal sweep rates. When the MAG switch, SW1001B, is set to the $\times 10$ position, R1047-R1048 and R1049 are connected in parallel with R1036 and R1046 (except in X-Y position of HORIZ DISPLAY switch). This additional resistance decreases the emitter degeneration of this stage and increases the gain 10 times. R1047, Mag Gain, is adjusted to provide calibrated magnified sweep rates. When the MAG switch is set to $\times 10$, the MAG ON light, B1050, is connected to the +150-volt supply through R1050. B1050 is ignited to indicate that the sweep is magnified. However, in the X-Y position of the HORIZ DISPLAY switch, —12 volts is connected across B1050 to keep it from igniting. The HORIZ DISPLAY switch also disconnects the MAG switch so the horizontal gain is correct for X-Y operation (horizontal deflection factor indicated by CH 1 VOLTS/DIV switch) regardless of the setting of the MAG switch.

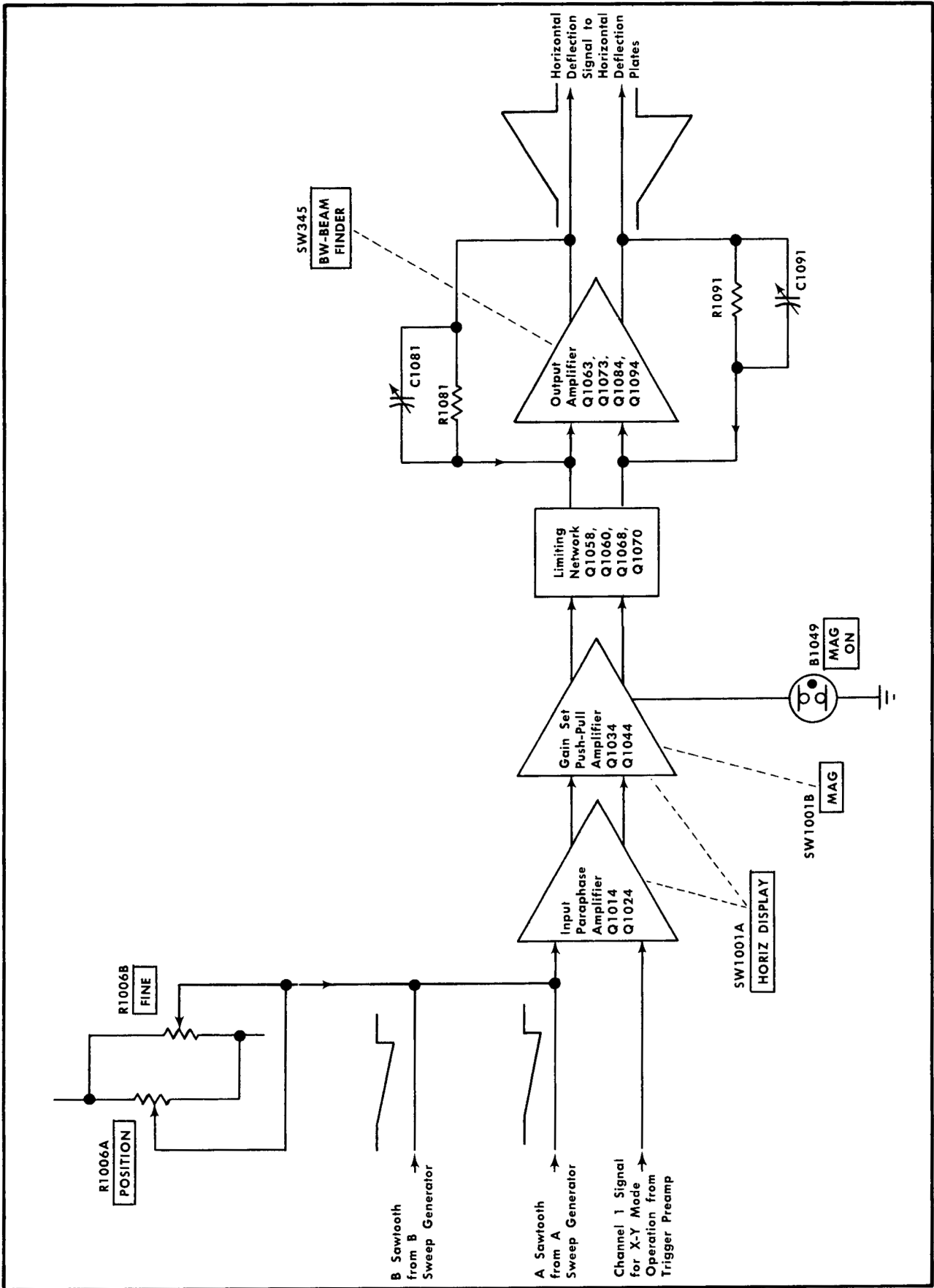

Fig. 3-16. Horizontal Amplifier detailed block diagram.

Circuit Description—Type 454/R454

NOTE

For minimum phase shift for high-frequency X-Y measurements, the MAG switch should be set to OFF even though it is disconnected by the HORIZ DISPLAY switch in the X-Y position.

Diodes D1035 and D1045 in the emitter circuits of Q1034 and Q1044 respectively, provide limiting to prevent the transistors in this range from going into cutoff or saturation when the sweep is magnified or the display is positioned to an extreme in either direction. For example, as the base of Q1034 is driven positive by the sweep signal (MAG switch set to $\times 10$), the current through R1035 increases until the voltage across D1035 is too low to keep it forward biased. D1035 then disconnects R1035 and the emitter coupling network R1036-R1046-R1047-R1048-R1049 to leave only R1033 as the emitter resistor for Q1034. Since R1033 adds more resistance in the emitter circuit, the gain of Q1034 is decreased and it also has more dynamic range. Although this produces distortion in the signal at the collector of Q1034, it occurs in the portion of the sawtooth which is not displayed on the CRT. This arrangement provides a faster recovery time for Q1034 and Q1044 to improve operation at fast sweep rates.

Output Amplifier and Limiting Network

The push-pull output of the Gain Set Push-Pull Amplifier stage is connected to the Output Amplifier. Each half of the Output Amplifier can be considered as a single-ended, feedback amplifier which amplifies the signal current at the input to produce a voltage output to drive the horizontal deflection plates of the CRT. The amplifiers have a low input impedance and require very little voltage change at the input to produce the desired output change. Transistors Q1058-Q1060, Q1068-Q1070 and diodes D1054-D1055 act as limiters to protect the amplifier from being overdriven by excessive current swing at the collectors of Q1034 and Q1044. Negative feedback is provided from the collectors of the final transistors, Q1084 and Q1094, to the bases of the input transistors, Q1063 and Q1073, through C1081-C1082-R1081 and C1091-C1092-R1091. C1081 and C1091 adjust the transient response of the amplifier so it has good linearity at fast sweep rates.

The Mag Register adjustment, R1053, balances the quiescent DC current to the base of Q1063 and Q1073 so a center-screen display does not change position when the MAG switch is changed from $\times 10$ to OFF.

The BW-BEAM FINDER switch, SW345, reduces horizontal scan by limiting the voltage swing of Q1084 and Q1094. Normally the collectors of these transistors are returned to +150 volts. However, when the BW-BEAM FINDER switch is pressed down to the BEAM FINDER position, the power from the unregulated +150-volt supply is interrupted and the collector voltage for Q1084 and Q1094 is supplied from +75 volts through D1084. This limits the output voltage swing to limit the trace within the graticule area.

LOW-VOLTAGE POWER SUPPLY

General

The Low-Voltage Power Supply circuit provides the operating power for this instrument from three regulated supplies and one unregulated supply. Electronic regulation¹⁰ is used

¹⁰Cutler, pp. 559-625.

to provide stable, low-ripple output voltages. Each regulated supply contains a short-protection circuit to prevent instrument damage if a supply is inadvertently shorted to ground. The Power Input stage includes the Voltage Selector Assembly. This assembly allows selection of the nominal operating voltage and regulating range for the instrument. Fig. 3-17 shows a detailed block diagram of the Power Supply circuit. A schematic of this circuit is shown on diagram 13 at the rear of this manual.

Power Input

Power is applied to the primary of transformer T1101 through the 115-volt line fuse F1101, POWER switch SW1101, thermal cutout TK1101, Voltage Selector switch SW1102 and Range Selector switch SW1103. The Voltage Selector switch SW1102 connects the split primaries of T1101 in parallel for 115-volt nominal operation, or in series for 230-volt nominal operation. A second line fuse, F1102, is connected into the circuit when the Voltage Selector switch is set to the 230-V position to provide the correct protection for 230-V operation (F1102 current rating is one-half of F1101). The fan is connected across one half of the split primary windings so it always has about 115 volts applied to it.

The Range Selector switch, SW1103, allows the instrument to regulate correctly on higher or lower than normal line voltages. Each half of the primary has taps above and below the 115-volt (230) nominal point. As the Range Selector switch, SW1103, is switched from LO to M to HI, more turns are effectively added to the primary winding and the turns ratio is decreased. This maintains a nearly constant voltage in the secondary of T1101 even though the primary voltage has increased.

Thermal cutout TK1101 provides thermal protection for this instrument. If the internal temperature of the instrument exceeds a safe operating level, TK1101 opens to interrupt the applied power. When the temperature returns to a safe level, TK1101 automatically closes to reapply the power.

—12-Volt Supply

The —12-Volt Supply provides the reference voltage for the remaining supplies. The output from the secondary of T1101 is rectified by bridge rectifier D1112A-D. This voltage is filtered by C1112-R1112 and then applied to the —12-Volt Series Regulator stage to provide a stable output voltage. The Series Regulator can be compared to a variable resistance which is changed to control the output current. The current through the Series Regulator stage is controlled by the Error Amplifier to provide the correct regulated output voltage.

The Error Amplifier is connected as a comparator. Reference voltage for the comparator is provided by zener diode D1116 which sets the base of Q1116 at about —9 volts. The base level of Q1124 is determined by voltage divider R1123-R1124-R1125 between the output of this supply and ground. R1124 is adjustable to set the output voltage of this supply to —12 volts. R1120 is the emitter resistor for both comparator transistors and the current through it divides between Q1116 and Q1124. The output current of the Error Amplifier stage controls the conduction of the Series Regulator stage (through Q1133). This output current is changed to provide a constant, low-ripple —12-volt output

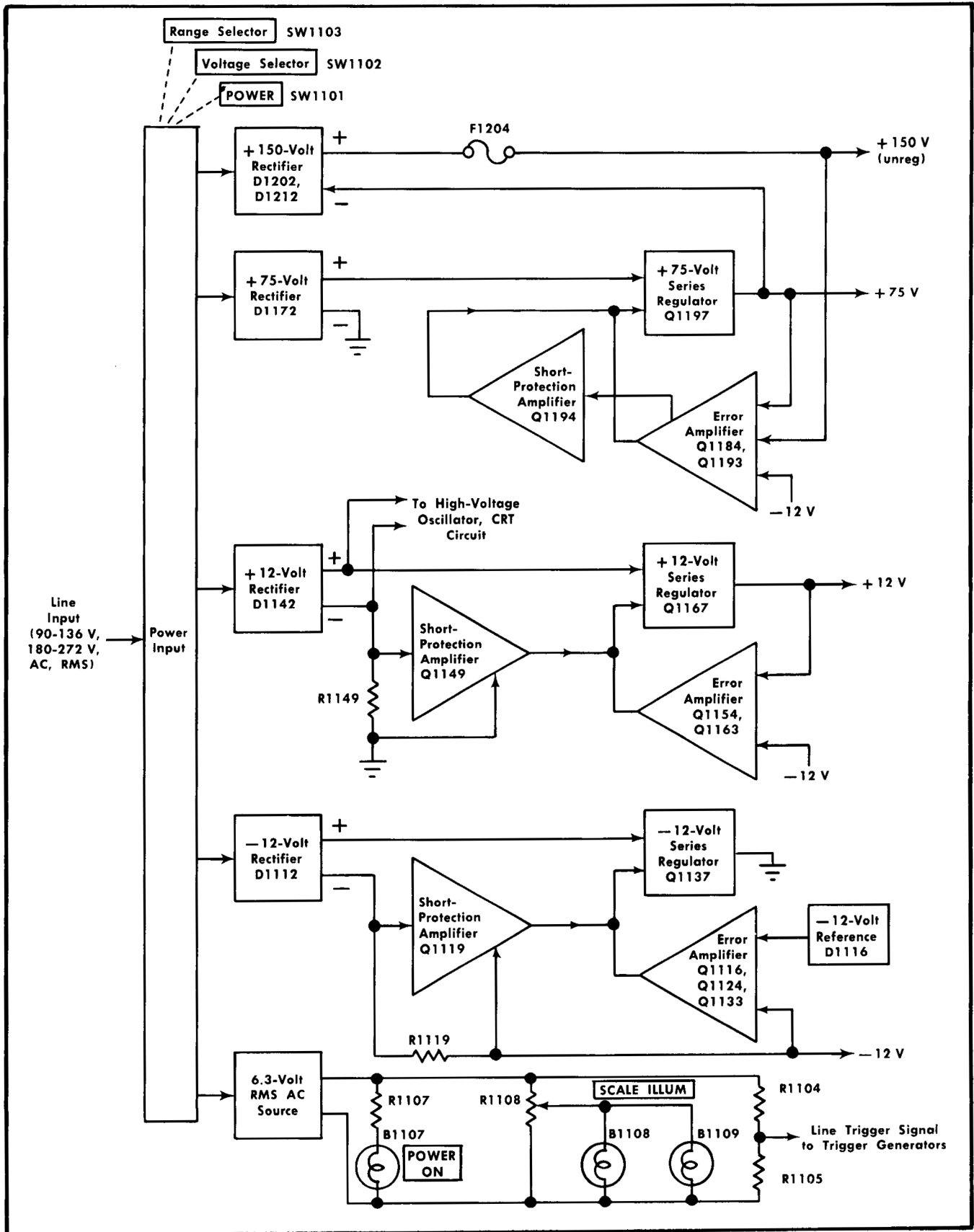

Fig. 3-17. Power Supply detailed block diagram.

Circuit Description—Type 454/R454

level. This occurs as follows: The comparator action of Q1116 and Q1124 attempts to maintain equal voltages at the bases of both transistors. If the -12 Volts adjustment, R1124, is turned clockwise, the current through Q1124 increases (Q1124 base tends to go more positive than the base of Q1116) and the current through Q1116 decreases. Decreased current through Q1116 produces less voltage drop across R1118 and the base of Q1133 goes positive. The emitter of Q1133 pulls the base of Q1137 positive to increase the current through the load, thereby increasing the output voltage of the supply. This places more voltage across divider R1123-R1124-R1125 and the divider action returns the base of Q1124 to about -9 volts. A similar, but opposite, action takes place when R1124 is turned counterclockwise so the base of Q1124 is more negative than the base of Q1116. The -12 Volts adjustment, R1124, is set to provide a -12 -volt level at the output of this supply.

The output voltage is regulated to provide a constant voltage to the load by feeding a sample of the output back to the Series Regulator, Q1137. For example, assume that the output voltage increases (more negative) because of a change in load or an increase in line voltage. This negative-going level at the output is applied across the voltage divider R1123-R1124-R1125 and the base of Q1124 goes negative also. This reduces the current flow through Q1124 which allows Q1116 to conduct more and its collector goes negative. When the collector of Q1116 goes negative, the bias on Q1133 is reduced, resulting in reduced current through the Series Regulator, Q1137. Reduced current through Q1137 also means that there is less current through the load and the output voltage decreases (less negative). In a similar manner the Series Regulator and Error Amplifier stages compensate for output changes due to ripple.

The Short-Protection Amplifier stage, Q1119, protects the -12 -Volt Supply if the output is shorted. For normal operation the emitter-base voltage of Q1119 is not enough to bias it on. However, when the output is shorted, high current is demanded from the Series Regulator, Q1137, and this current flows through R1119. The voltage drop across R1119 becomes sufficient to forward bias Q1119 and its collector current produces an increased voltage drop across R1118. The increased voltage drop across R1118 reduces the current flow of both Q1133 and Q1137 to limit the output current. D1125 protects this circuit from damage if its output is shorted to one of the positive supplies.

This instrument is designed so that all power is interrupted if any one of the supplies is shorted to ground. D1120 reduces the -12 -Volt Supply output if the $+12$ -volts output is shorted. Since the operating level for Q1116 and Q1133 is obtained from the $+75$ -volt output through R1118, the -12 -Volt Supply is shut off if the $+75$ -volt output is shorted. Likewise, since both the $+75$ -Volt Supply and the $+12$ -Volt Supply are referenced to the -12 -volt output, these supplies are shut off if the -12 -volt output is shorted.

+ 12-Volt Supply

Rectified voltage for operation of the $+12$ -Volt Supply is provided by D1142A-D. This voltage is filtered by C1142-R1142 and connected to the $+12$ -Volt Series Regulator and to the High-Voltage Oscillator stage in the CRT Circuit. Reference voltage for this supply is provided by voltage divider R1157-R1158-R1159 between the regulated -12 volts and the output of this supply. The -12 volts is held stable by

the -12 -Volt Supply as discussed previously. If the $+12$ -volt output changes, this change appears at the base of Q1154 as an error signal. Regulation of the output voltage is controlled by the $+12$ -Volt Series Regulator stage, Q1167, in a similar manner to that described for the -12 -Volt Supply. The $+12$ Volts adjustment, R1158, sets the output level to $+12$ volts. D1158 and D1159 provide thermal compensation for the Error Amplifier. C1155-R1155 improve response of the regulator circuit to low-frequency changes at the output.

Shorting protection is provided by Q1149 and R1149. If the output of this supply is shorted, Q1149 is biased on to limit the conduction of the Series Regulator in the same manner as described for the -12 -Volt Short-Protection Amplifier. D1154 protects Q1154 when the output of this supply is shorted.

+75-Volt Supply

D1172A-D provides the rectified voltage for the $+75$ -Volt Supply. C1172 and R1172 filter the rectified voltage which is connected to the $+75$ -Volt Series Regulator. Reference voltage for this supply is provided by voltage-divider R1187-R1188-R1189 between the regulated -12 volts and the output of this supply. Since the -12 volts is held stable by the -12 -Volt Regulator circuit, any change at the base of Error Amplifier Q1184 is due to a change at the output of the $+75$ -Volt Supply. Regulation of the output voltage is controlled by Error Amplifier Q1184-Q1193 and Series Regulator, Q1197, in a manner similar to that described for the -12 -Volt Supply. The $+75$ Volts adjustment, R1188, sets the quiescent conduction level of the Error Amplifier stage to provide an output level of $+75$ volts. The output of the $+150$ -Volt Supply (unregulated) is connected to the Error Amplifier to provide the required collector level for stable operation. Zener diode D1190 sets the collector of Q1193 at about $+80$ volts and zener diode D1182 establishes a level of about $+105$ volts at the junction of R1182-R1183. Then, R1183, zener diode D1184 and R1184 drop this voltage to the correct level for the operation of Q1184. D1189 provides thermal compensation for the Error Amplifier.

Q1194 protects this supply if the output is shorted to ground. If this occurs, excess current is demanded from the Series Regulator, Q1197, and this additional current through R1197 raises the emitter of Q1197 more positive. This produces a corresponding change at the base of Q1197 which is connected to Q1194 through divider R1193-R1194. Under normal conditions, this divider sets the base level of Q1194 so Q1194 is about zero biased. However, when the output is shorted, the positive-going change across the divider R1193-R1194 raises the base level of Q1194 positive and it is forward biased. When Q1194 comes on, its collector goes negative and it turns Q1193 off to reduce the current flow through the Series Regulator stage, Q1197, and the output voltage drops toward ground. The output current also decreases and remains low until the excessive load is removed. D1193 protects Q1193 and D1185 protects Q1184 from excess reverse voltage when the output is shorted. D1196 protects the $+75$ -Volt Supply from damage if it is shorted to the -12 volt supply.

+ 150-Volt Unregulated Supply

Rectifiers D1202 and D1212 provide the unregulated output for the $+150$ -Volt Supply. The output of the $+75$ -Volt Supply is connected to the negative side of the $+150$ -Volt Sup-

ply to elevate the output level to +150 volts. Diodes D1202 and D1212 are connected as a full-wave center-tapped rectifier and the output is filtered by C1202-C1204-R1202-R1204 to hold the output level at about +150 volts. Fuse F1204 protects this supply if the output is shorted.

6.3-Volt RMS AC Source

The 6.3-volt RMS secondary winding of T1101 provides power for the POWER ON light, B1107, and the scale illumination lights B1108 and B1109. The current through the scale illumination lights is controlled by the SCALE ILLUM control, R1108, to change the illumination of the graticule lines. Voltage divider R1104-R1105 provides a sample of the line voltage to the A and B Trigger Generator circuits for internal triggering at the line frequency.

VOLTAGE DISTRIBUTION

Diagram 14 shows the distribution of the output voltages from the Power Supply circuit to the circuit boards in this instrument. The decoupling networks which provide decoupled operating voltages are shown on this Diagram and are not repeated on the individual circuit diagrams.

CALIBRATOR

General

The Calibrator circuit produces a square-wave output with accurate amplitude and frequency. This output is available as a square-wave voltage at the 1 V CAL 1 kHz connector and as a square-wave current through the CURRENT PROBE CAL loop. Fig. 3-18 shows a detailed block diagram of the Calibrator circuit. A schematic of this circuit is shown on diagram 15 at the rear of this manual.

Oscillator

Q1275 and its associated circuitry comprises a tuned-collector oscillator.¹¹ Frequency of oscillation is determined by the LC circuit comprised of the primary of variable transformer T1275 in parallel with C1275. The accuracy and stability required to provide an accurate time and frequency reference is obtained by using a capacitor and transformer which have opposite temperature coefficients.

The oscillations of the LC circuit, T1275-C1275, are sustained by the feedback winding of T1275 connected to the base of Q1275. C1286 connects a sample of the output from the LC circuit to the base of Q1285. The regenerative feedback from the emitter of Q1285 to the emitter of Q1275 produces fast changeover between Q1275 and Q1285 to provide a fast risetime on the output square wave. Frequency of the output square wave can be adjusted by varying the inductance of the primary winding of T1275 slightly. The square-wave signal at the collector of Q1285 is connected to the Output Amplifier.

Output Amplifier

The output signal from the oscillator stage overdrives Q1294 to produce the accurate square wave at the output. When the base of Q1294 goes positive, Q1294 is cut off and the output signal drops negative to ground. When the base goes negative, Q1294 is driven into saturation and the output signal rises positive to about +12 volts. The collector current of Q1294 flows through R1296, R1298 and the CURRENT PROBE CAL loop on the side panel. Current through the CURRENT PROBE CAL loop is a five-milliampere square wave. The output voltage is connected from the divider R1296-R1298 to the 1 V CAL 1 kHz connector through R1299. The output of the +12-Volt Supply is adjusted for an accurate one-volt output signal at the 1 V CAL 1 kHz connector.

¹¹Lloyd P. Hunter, pp. 14-3 — 14-7.

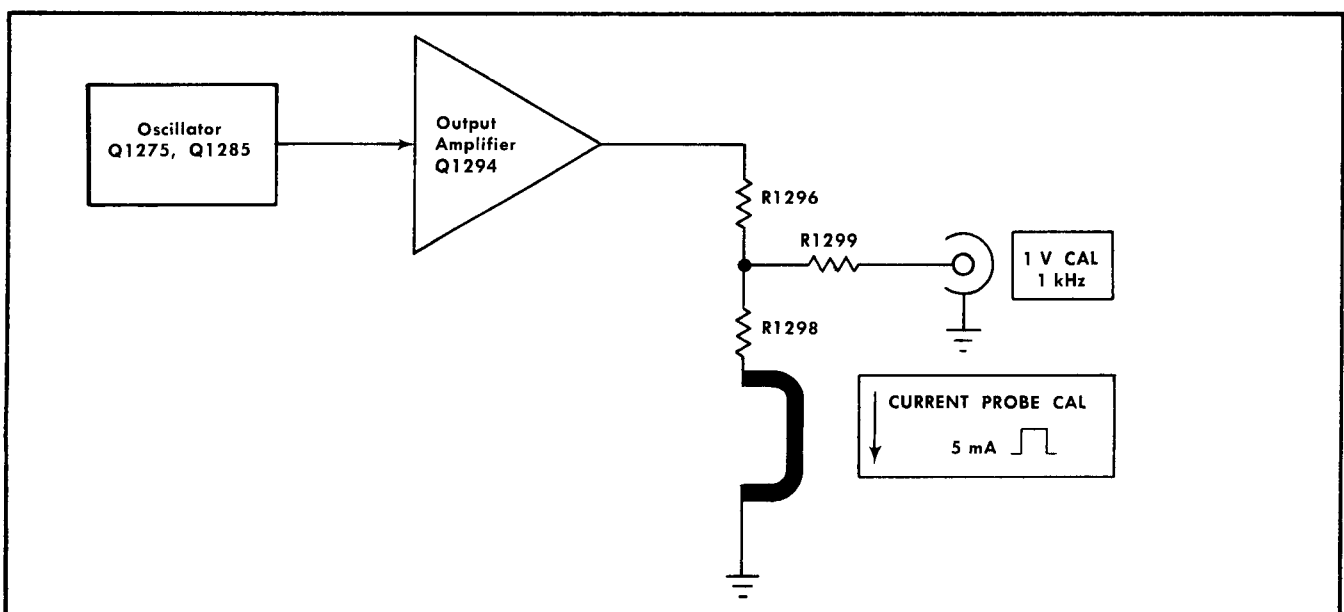

Fig. 3-18. Calibrator detailed block diagram.

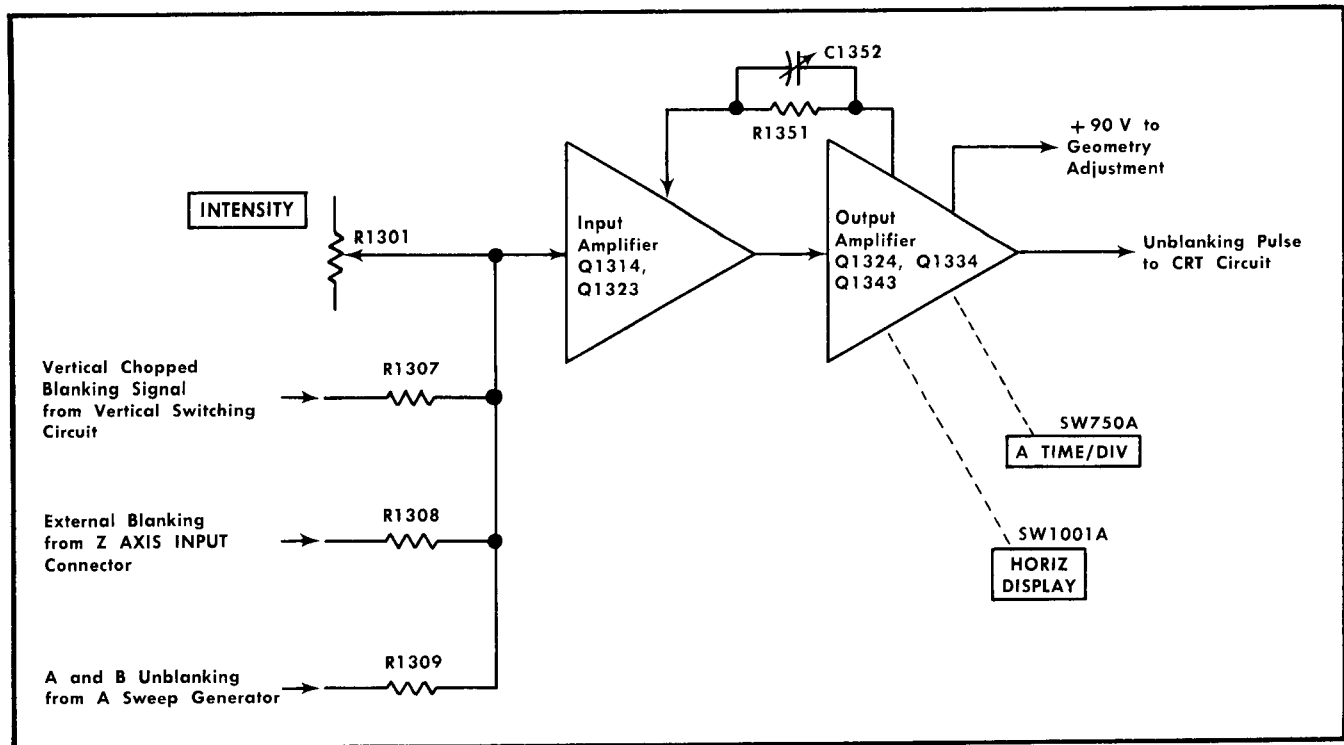

Fig. 3-19. Z Axis Amplifier detailed block diagram.

Z AXIS AMPLIFIER

General

The Z Axis Amplifier circuit controls the CRT intensity level from several inputs. The effect of these input signals is to either increase or decrease the trace intensity, or to completely blank portions of the display. Fig. 3-19 shows a detailed block diagram of the Z Axis Amplifier circuit. A schematic of this circuit is shown on diagram 16 at the rear of this manual.

Input Amplifier

The input transistor, Q1314, in the Input Amplifier stage is a current-driven, low input impedance amplifier. It provides termination for the input signals as well as isolation between the input signals and the following stages. The current signals from the various control sources are connected to the emitter of Q1314 and the sum or difference of the signals determines the collector conduction level. D1314 and D1318 in the collector provide limiting protection at minimum intensity. When the INTENSITY control is set fully counterclockwise (minimum), the collector current of Q1314 is reduced and its collector rises positive. D1318 is reverse biased to block the control current at the base of Q1323, and D1314 is forward biased to protect the circuit by clamping the collector of Q1314 about 0.5 volts more positive than the emitter level of Q1323. This limiting action also takes place when a blanking signal is applied. The clamping action of D1314 allows Q1314 to recover faster to produce a sharper display with sudden changes in blanking level. At normal intensity levels, D1314 is reverse biased and the signal from Q1314 is coupled to emitter follower Q1323 through D1318.

The input signals vary the current drive to the emitter of Q1314 which produces a collector level that determines the brilliance of the display. The INTENSITY control sets the quiescent level at the emitter of Q1314. When R1301 is turned in the clockwise direction, less current from the INTENSITY control is added to the emitter circuit of Q1314 which results in an increase in collector current to provide a brighter trace. However, the vertical chopped blanking, Z axis input and A and B unblanking signals determine whether the trace is visible with a given INTENSITY control setting (not at maximum). The vertical chopped blanking signal blanks the trace during dual-trace switching. This signal decreases the current through Q1314 during the trace switching time to blank the CRT display. The external blanking input allows an external signal connected to the Z AXIS INPUT connector to change the trace intensity. A positive-going signal connected to the Z AXIS INPUT connector decreases trace intensity and a negative-going signal increases trace intensity. The A and B unblanking signal from the A Sweep Generator circuit blanks the CRT during sweep retrace and recovery time so there is no display on the screen. When the A and/or B Sweep Generator circuits are reset and recovered (see A and B Sweep Generator discussions for more information), the next trigger pulse initiates the sweep and an unblanking signal is generated in the A or B Sweep Generator circuit that goes negative to allow the emitter current of Q1314 to reach the level established by the INTENSITY control and the other blanking inputs.

Output Amplifier

The resultant signal produced from the various inputs by the Input Amplifier stage is connected to the base of Q1324

through C1324 and the base of Q1334 through R1330. These transistors are connected as a collector-coupled complementary amplifier.¹² This configuration provides a linear, fast output signal with minimum quiescent power.

The overall Z Axis Amplifier circuit is a shunt-feedback operational amplifier with feedback connected from the Output Amplifier stage to the Input Amplifier stage through C1351-C1352-R1351. The output voltage is determined by the input current \times the feedback resistor and is shown by the formula: $E_{out} = i_{in} \times R_{FB}$ where R1351 is R_{FB} . The A and B unblanking input current change is approximately two milliamperes. Therefore, the maximum output voltage change is about 60 volts ($2 \text{ mA} \times 30.1 \text{ k}\Omega$). C1352 adjusts the feedback circuit for optimum step response so the unblanking gate signal at the output of this circuit has a fast rise with minimum overshoot or ringing. Overshoot or ringing on the unblanking gate would produce a display with uneven intensity immediately following sudden changes in blanking level.

The emitter source voltage for Q1324 is changed by the HORIZ DISPLAY switch, SW1001A, and the A TIME/DIV switch, SW750A, to prevent phosphor burning. When the HORIZ DISPLAY switch is set to B (DELAYED SWEEP) or X-Y, +150 volts is connected to the emitter of Q1324 through D1326-R1326-R1327. D1353 is reverse biased and the +75 volts at its anode is disconnected from the circuit. However, in the A and A INTEN DURING B positions of the HORIZ DISPLAY switch, the emitter source for Q1324 is determined by the A TIME/DIV switch. In the .1 s to 5 s positions of the A TIME/DIV switch, the emitter of Q1324 is returned to +75 volts through D1326-R1326-R1327 and D1353. This less positive emitter source for Q1324 limits the collector level of Q1324 and Q1334 to about +75 volts to protect the

¹²ibid., pp. 11-57 — 11-62.

CRT phosphor in these switch positions. In the .05 μ s to 50 ms positions, the emitter source for Q1324 is +150 volts. Operation is the same as in the B (DELAYED SWEEP) and X-Y positions of the HORIZ DISPLAY switch.

Zener diode D1356 connected between +75 volts and +150 volts through D1357-R1357-R1358 produces a +90-volt level at the cathode of D1356. This voltage establishes the correct operating level for the Geometry adjustment in the CRT Circuit and establishes the correct collector level for Q1343. D1343, connected from base to emitter of Q1343, improves the response of Q1343 to negative-going signals. When the base of Q1343 is driven negative to cutoff, D1343 is forward biased and conducts the negative-going portion of the unblanking signal. This provides a fast falling edge on the unblanking gate to quickly turn the display off. The output unblanking gate at the emitter of Q1343 is connected to the CRT circuit through R1344.

CRT CIRCUIT

General

The CRT Circuit provides the high-voltage and control circuits necessary for operation of the cathode-ray tube (CRT). Fig. 3-20 shows a detailed block diagram of the CRT Circuit. A schematic of this circuit is shown on diagram 17 at the rear of this manual.

High-Voltage Oscillator

Q1430 and associated circuitry comprise a class C oscillator¹³ to produce the drive for the high-voltage transformer, T1430. When the instrument is turned on, the current through R1425 charges C1419 positive and Q1430 is forward biased. The collector current of Q1430 increases

¹³ibid., pp. 14-19 — 14-21.

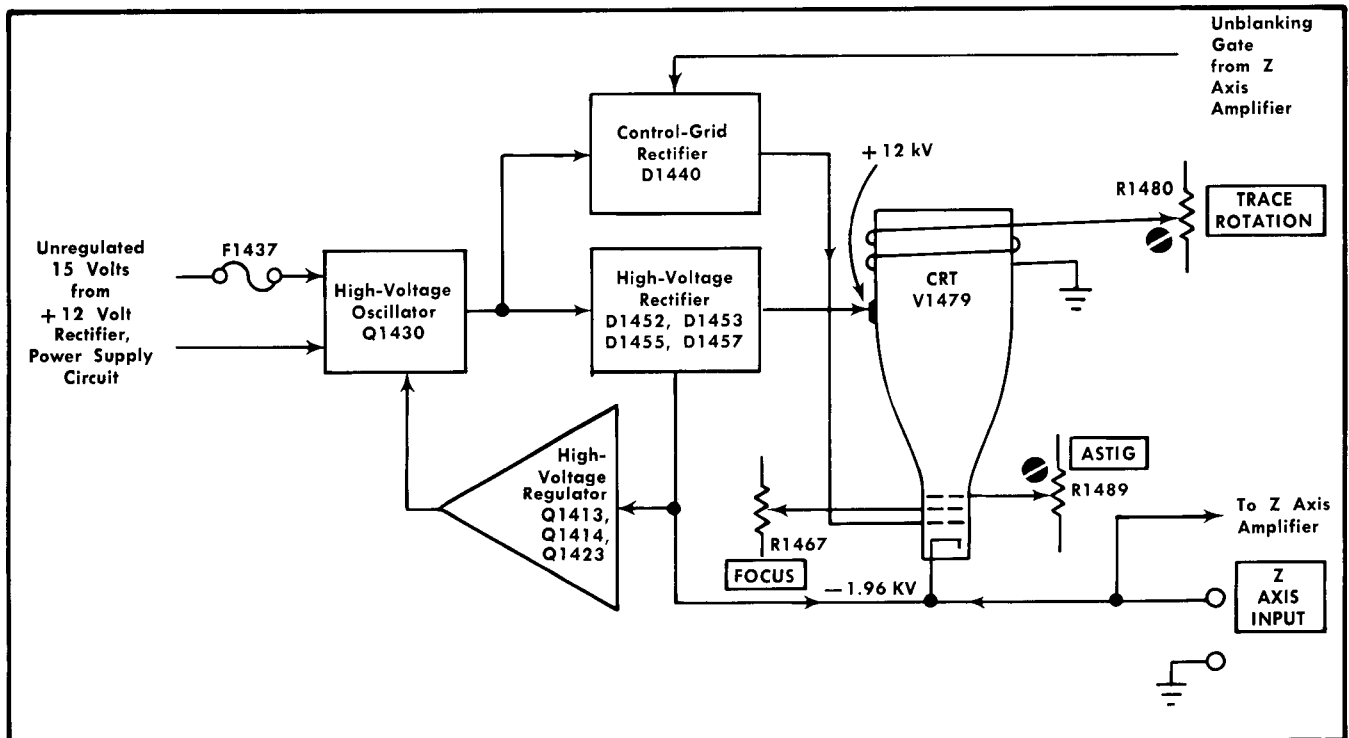

Fig. 3-20. CRT Circuit detailed block diagram.

Circuit Description—Type 454/R454

and a voltage is developed across the collector winding of T1430. This produces a corresponding current increase in the feedback winding of T1430 which is connected to the base of Q1430 and this feedback current increases the voltage level at the base of Q1430. When C1419 is fully charged, the base current of Q1430 stabilizes and there is no changing current in the collector winding of T1430. Since there is no change in current through the collector winding, there is no feedback voltage to the base and the collector current of Q1430 begins to decrease. This produces a current in the feedback winding of T1430 and a corresponding negative voltage (less positive) at the base of Q1430 which begins to turn it off. C1419 slowly discharges to the negative potential on the base of Q1430. Once again the current flow through the collector winding ceases and there is no feedback to the base of Q1430. Then C1419 begins to recharge through R1425 and the base level of Q1430 rises positive until it is forward biased. Q1430 returns to conduction and another cycle begins. The signal produced across T1430 is a sine wave with a frequency of 40 to 50 kilohertz. The amplitude of the oscillations at the collector of Q1430 is controlled by the High-Voltage Regulator stage.

Fuse F1437 protects the +12-Volt Supply if the High-Voltage Oscillator stage is shorted. Filter network L1437-C1437 prevents current changes in this stage from affecting the +12-volt regulator circuit.

High-Voltage Regulator

Feedback from the secondary of T1430 is connected to the base of Q1414 through the voltage divider network R1405-R1412. This sample of the output voltage is amplified by Q1414 and Q1413 and applied to the base of Q1423. Amplitude of the oscillations at the collector of Q1430 is determined by the average DC level at the emitter Q1423.

Regulation takes place as follows: If the output voltage at the -1960 V test point starts to go positive (less negative), a sample of this positive-going voltage is applied to the base of Q1414. Q1414 is forward biased and it, in turn, forward biases Q1413 to increase the conduction of Q1423. An increase in current through Q1423 raises the average voltage level at its emitter which is connected to the base of Q1430 through the feedback winding of T1430. A more positive level at the base of Q1430 increases its collector current to produce a larger induced voltage in the secondary of T1430. This increased voltage appears as a more negative voltage level at the -1960 V test point to correct the original positive-going change. By sampling the output from the negative high-voltage rectifier in this manner, the total output of the high-voltage supply is held constant.

Output voltage level of the high-voltage supply is set by the High Voltage adjustment, R1401, in the base circuit of Q1414. This adjustment sets the conduction level of Q1414 which controls the quiescent conduction of Q1413, Q1423 and Q1430 similar to the manner just described for regulation.

High-Voltage Rectifiers

The high-voltage transformer, T1430, has three output windings. One of the windings provides filament voltage for the cathode-ray tube. The filament voltage can be obtained from the high-voltage supply since the CRT has a very low filament-current drain. Two high-voltage windings pro-

vide the negative and positive accelerating voltage, and the CRT grid bias voltage. All of these outputs are regulated by the High-Voltage Regulator stage in the primary of T1430 to maintain a constant output voltage.

Positive accelerating potential for the CRT anode is supplied by voltage tripler D1453-D1455-D1457. This rectified voltage is filtered by the network C1460-R1460-R1461 to provide a constant output of about +12 kilovolts. Ground return for this supply is through the resistive helix inside the CRT to pin 12 of the CRT, and then to ground through R1472.

The negative accelerating potential for the CRT cathode is supplied by the half-wave rectifier D1452. Voltage output is about -1.96 kilovolts. A sample of this output voltage is connected to the High-Voltage Regulator stage to provide a regulated high-voltage output.

The half-wave rectifier D1440 provides a negative voltage for the control grid of the CRT. Output level is adjustable by the CRT Grid Bias adjustment, R1447. The neon bulbs, B1473-B1474-B1475, provide protection for the CRT Circuit if the voltage difference between the control grid and the CRT cathode exceeds about 165 volts. The unblanking gate from the Z Axis Amplifier circuit is connected to the positive side of this circuit to produce a change in output voltage to control CRT intensity, unblanking, dual-trace blanking and intensity modulation.

CRT Control Circuits

Focus of the CRT display is controlled by the FOCUS control, R1467. The divider R1463-R1469 is connected between the CRT cathode supply and ground. The voltage applied to the focus grid is more positive (less negative) than the voltage on either the control grid or the CRT cathode. The ASTIG adjustment, R1489, which is used in conjunction with the FOCUS control to provide a well-defined display, varies the positive level on the astigmatism grid.

The Geometry adjustment, R1482, varies the positive level on the horizontal deflection plate shields to control the overall geometry of the display. The +90-volt source for this control is provided by zener diode D1356 in the Z Axis Amplifier circuit.

Two adjustments control the trace alignment by varying the magnetic field around the CRT. The Y Axis Align adjustment, R1485, controls the current through L1485 which affects the CRT beam after vertical deflection but before horizontal deflection. The TRACE ROTATION adjustment, R1480, controls the current through L1480 and affects both vertical and horizontal rotation of the beam.

External Z Axis Input

A signal applied to the Z AXIS INPUT connector is applied to the CRT cathode through C1479-R1477-C1477 and to the Z Axis Amplifier circuit. Low frequency Z-axis signals are blocked from the CRT circuit by C1477. They are connected to the Z Axis Amplifier circuit to produce an increase or decrease in intensity, depending upon polarity. C1477 couples high-frequency signals to the CRT cathode to produce the same resultant display as the Z Axis Amplifier circuit produces for low-frequency intensity-modulation signals. This configuration operates as a crossover network to provide nearly constant intensity modulation from DC to 50 megahertz.

SECTION 4

MAINTENANCE

Introduction

This section of the manual contains maintenance information for use in preventive maintenance, corrective maintenance or troubleshooting of the Type 454.

Cover Removal

The top and bottom covers of the instrument are held in place by thumb screws located on each side of the instrument. To remove the covers, loosen the thumb screws and slide the covers off the instrument. The covers protect the instrument from dust in the interior. The covers also direct the flow of cooling air and reduce the EMI radiation from the instrument.

PREVENTIVE MAINTENANCE

General

Preventive maintenance consists of cleaning, visual inspection, lubrication, etc. Preventive maintenance performed on a regular basis may prevent instrument breakdown and will improve the reliability of this instrument. The severity of the environment to which the Type 454 is subjected determines the frequency of maintenance. A convenient time to perform preventive maintenance is preceding recalibration of the instrument.

Cleaning

The Type 454 should be cleaned as often as operating conditions require. Accumulation of dirt in the instrument can cause overheating and component breakdown. Dirt on components acts as an insulating blanket and prevents efficient heat dissipation. It also provides an electrical conduction path.

CAUTION

Avoid the use of chemical cleaning agents which might damage the plastics used in this instrument. Avoid chemicals which contain benzene, toluene, xylene, acetone or similar solvents.

The top and bottom covers provide protection against dust in the interior of the instrument. Operation without the covers in place necessitates more frequent cleaning. The front cover provides dust protection for the front panel and the CRT face. The front cover should be installed for storage or transportation. The plastic cover supplied with the Type 454 provides protection for the outside of the instrument during transportation or storage. The pocket on the side also provides a convenient place to carry this instruction manual.

Air Filter. The air filter should be visually checked every few weeks and cleaned or replaced if dirty. More frequent

inspections are required under severe operating conditions. If the filter is to be replaced, order new air filters from your local Tektronix Field Office or representative; order by Tektronix Part No. 378-0033-00. The following procedure is suggested for cleaning the filter.

1. Remove the filter by pulling it out of the retaining frame on the rear panel. Be careful not to drop any of the accumulated dirt into the instrument.
2. Flush the loose dirt from the filter with a stream of hot water.
3. Place the filter in a solution of mild detergent and hot water and let it soak for several minutes.
4. Squeeze the filter to wash out any dirt which remains.
5. Rinse the filter in clear water and allow it to dry.
6. Coat the dry filter with an air-filter adhesive (available from air conditioner suppliers or order Tektronix Part No. 006-0580-00).
7. Let the adhesive dry thoroughly.
8. Re-install the filter in the retaining frame.

Exterior. Loose dust accumulated on the outside of the Type 454 can be removed with a soft cloth or small paint brush. The paint brush is particularly useful for dislodging dirt on and around the front-panel controls. Dirt which remains can be removed with a soft cloth dampened in a mild detergent and water solution. Abrasive cleaners should not be used.

CRT. Clean the plastic light filter, faceplate protector and the CRT face with a soft, lint-free cloth dampened with denatured alcohol. The CRT mesh filter can be cleaned in the following manner:

1. Hold the filter in a vertical position and brush lightly with a soft #7 water-color brush to remove light coatings of dust or lint.
2. Greasy residues or dried-on dirt can be removed with a solution of warm water and a neutral-PH liquid detergent. Use the brush to lightly scrub the filter.
3. Rinse the filter thoroughly in clean water and allow to air dry.
4. If the lint or dirt remains, use clean low-pressure air to remove. Do not use tweezers or other hard cleaning tools on the filter as the special finish may be damaged.
5. When not in use, store the mesh filter in a lint-free, dust-proof container such as a plastic bag.

Interior. Dust in the interior of the instrument should be removed occasionally due to its electrical conductivity under high-humidity conditions. The best way to clean the interior is to blow off the accumulated dust with dry, low-velocity

Maintenance—Type 454/R454

air. Remove any dirt which remains with a soft paint brush or a cloth dampened with a mild detergent and water solution. A cotton-tipped applicator is useful for cleaning in narrow spaces or for cleaning ceramic terminal strips and circuit boards.

The high-voltage circuits, particularly parts located in the high-voltage compartment and the area surrounding the post-deflection anode connector, should receive special attention. Excessive dirt in these areas may cause high-voltage arcing and result in improper instrument operation.

Lubrication

General. The reliability of potentiometers, rotary switches and other moving parts can be maintained if they are kept properly lubricated. Use a cleaning-type lubricant (e.g., Tektronix Part No. 006-0218-00) on switch contacts. Lubricate switch detents with a heavier grease (e.g., Tektronix Part No. 006-0219-00). Potentiometers which are not permanently sealed should be lubricated with a lubricant which does not affect electrical characteristics (e.g., Tektronix Part No. 006-0220-00). This lubricant can also be used on shaft bushings. Do not over lubricate. A lubrication kit containing the necessary lubricants and instructions is available from Tektronix, Inc. Order Tektronix Part No. 003-0342-00.

Fan. The fan-motor bearings are sealed and do not require lubrication.

Visual Inspection

The Type 454 should be inspected occasionally for such defects as broken connections, broken or damaged ceramic strips, improperly seated transistors or nuvistors, damaged circuit boards and heat damaged parts.

The corrective procedures for most visible defects is obvious; however, particular care must be taken if heat-damaged components are found. Overheating usually indicates other trouble in the instrument; therefore, it is important that the cause of overheating be corrected to prevent recurrence of the damage.

Transistor and Nuvisor Checks

Periodic checks of the transistors and nuvistors in the Type 454 are not recommended. The best check of transistor or nuvisor performance is its actual operation in the instrument. More details on checking transistor and nuvisor operation are given under Troubleshooting.

Recalibration

To assure accurate measurements, check the calibration of this instrument after each 1000 hours of operation or every six months if used infrequently. In addition, replacement of components may necessitate recalibration of the affected circuits. Complete calibration instructions are given in the Calibration section.

The calibration procedure can also be helpful in localizing certain troubles in the instrument. In some cases, minor troubles may be revealed and/or corrected by recalibration.

TROUBLESHOOTING

Introduction

The following information, is provided to facilitate troubleshooting of the Type 454, if trouble develops. Information contained in other sections of this manual should be used along with the following information to aid in locating the defective component. An understanding of the circuit operation is very helpful in locating troubles. See the Circuit Description section for complete information.

Troubleshooting Aids

Diagrams. Circuit diagrams are given on foldout pages in Section 9. The component number and electrical value of each component in this instrument are shown on the diagrams. Each main circuit is assigned a series of component numbers. Table 4-1 lists the main circuits in the Type 454 and the series of component numbers assigned to each. Important voltages and waveforms are also shown on the diagrams. The portions of the circuit mounted on circuit boards are enclosed with a blue line.

TABLE 4-1

Component Numbers

| Component Numbers on Diagrams | Diagram Number | Circuit |
|-------------------------------|----------------|---------------------------|
| 1 - 99 | 1 | Channel 1 Vertical Preamp |
| 100 - 199 | 2 | Channel 2 Vertical Preamp |
| 200 - 299 | 3 | Vertical Switching |
| 300 - 499 | 4 | Vertical Output Amplifier |
| 500 - 599 | 5 | Trigger Preamp |
| 600 - 699 | 6 | A Trigger Generator |
| 700 - 799 | 7 | A Sweep Generator |
| 800 - 899 | 8 | B Trigger Generator |
| 900 - 999 | 9 | B Sweep Generator |
| 1000 - 1099 | 11 | Horizontal Amplifier |
| 1100 - 1199 | 13 | Power Supply |
| 1200 - 1269 | 14 | Power Distribution |
| 1270 - 1299 | 15 | Calibrator |
| 1300 - 1399 | 16 | Z Axis Amplifier |
| 1400 - 1499 | 17 | CRT Circuit |

Switch Wafer Identification. Switch wafers shown on the diagrams are coded to indicate the position of the wafer in the complete switch assembly. The numbered portion of the code refers to the wafer number counting from the front, or mounting end of the switch, toward the rear. The letters F and R indicate whether the front or rear of the wafer performs the particular switching function. For example, a wafer designated 2R indicates that the rear of the second wafer (from the front) is used for this particular switching function.

Circuit Boards. Figs. 4-9 through 4-19 show the circuit boards used in the Type 454. Fig. 4-8 shows the location of each board within the instrument. Each electrical component on the boards is identified by its circuit number. The circuit

boards are also outlined on the diagrams with a blue line. These pictures, used along with the diagrams, aid in locating the components mounted on the circuit boards.

Wiring Color-Code. All insulated wire and cable used in the Type 454 is color-coded to facilitate circuit tracing. Signal carrying leads are identified with one or two colored stripes. Voltage supply leads are identified with three stripes to indicate the approximate voltage using the EIA resistor color code. A white background color indicates a positive voltage and a tan background indicates a negative voltage. The widest color stripe identifies the first color of the code. Table 4-2 gives the wiring color-code for the power-supply voltages used in the Type 454.

TABLE 4-2
Power Supply Wiring Color Code

| Supply | Back-ground Color | 1st Stripe | 2nd Stripe | 3rd Stripe |
|-----------|-------------------|------------|------------|------------|
| -12 vclt | Tan | Brown | Red | Black |
| +12 volt | White | Brown | Red | Black |
| +75 volt | White | Violet | Green | Black |
| +150 volt | White | Brown | Green | Brown |

Resistor Color Code. In addition to the brown composition resistors, some metal-film resistors (identifiable by

their gray body color) and some wire-wound resistors (usually light blue or gray-green) are used in the Type 454. The resistance values of wire-wound resistors are printed on the body of the component. The resistance values of composition resistors and metal-film resistors are color-coded on the components with EIA color-code (some metal-film resistors may have the value printed on the body). The color-code is read starting with the stripe nearest the end of the resistor. Composition resistors have four stripes which consist of two significant figures, a multiplier and a tolerance value (see Fig. 4-1). Metal-film resistors have five stripes consisting of three significant figures, a multiplier and a tolerance value.

Capacitor Marking. The capacitance values of common disc capacitors and small electrolytics are marked in microfarads on the side of the component body. The white ceramic capacitors used in the Type 454 are color coded in picofarads using a modified EIA code (see Fig. 4-1).

Diode Color Code. The cathode end of each glass encased diode is indicated by a stripe, a series of stripes or a dot. For most silicon or germanium diodes with a series of stripes, the color-code also indicates the type of diode and identifies the Tektronix Part Number using the resistor color-code system (e.g., a diode color-coded blue-brown-gray-green indicates diode type 6185 with Tektronix Part Number 152-0185-00). The cathode and anode end of metal-encased diodes can be identified by the diode symbol marked on the

Composition Resistors: (Diagram showing 4 bands: 1, 2, M, T)

Metal-Film Resistors: (Diagram showing 5 bands: 1, 2, 3, M, T)

Ceramic Capacitors: (Diagram showing 5 bands: TC, 1, 2, M, T)

① ② and ③ —1st, 2nd and 3rd significant figures;
 (M) —multiplier; (T) —tolerance;
 (TC) —temperature coefficient.

| Color | Significant Figures | Multiplier | | Tolerance | |
|--------|---------------------|------------------|------------------|-----------|-----------------------------|
| | | Resistors | Capacitors | Resistors | Capacitors |
| Silver | --- | 10 ⁻² | --- | ±10% | --- |
| Gold | --- | 10 ⁻¹ | --- | ±5% | --- |
| Black | 0 | 1 | 1 | --- | ±20% or 2 pF* |
| Brown | 1 | 10 | 10 | ±1% | ±1% or 0.1 pF* |
| Red | 2 | 10 ² | 10 ² | ±2% | ±2% |
| Orange | 3 | 10 ³ | 10 ³ | ±3% | ±3% |
| Yellow | 4 | 10 ⁴ | 10 ⁴ | ±4% | +100% -0% |
| Green | 5 | 10 ⁵ | 10 ⁵ | ±0.5% | ±5% or 0.5 pF* |
| Blue | 6 | 10 ⁶ | 10 ⁶ | --- | --- |
| Violet | 7 | --- | --- | --- | --- |
| Gray | 8 | --- | 10 ⁻² | --- | +80% -20% or 0.25 pF* |
| White | 9 | --- | 10 ⁻¹ | --- | ±10% or 1 pF* |
| (none) | --- | --- | --- | ±20% | ±10% or 1 pF* |

***For capacitance of 10 pF or less.**

NOTE: (T) and/or (TC) color code for capacitors depends upon manufacturer and capacitor type. May not be present in some cases.

Fig. 4-1. Color-code for resistors and ceramic capacitors.

Maintenance—Type 454/R454

body. Fig. 4-2 identifies the cathode and anode end of the strip-line tunnel diodes.

Transistor and Nuvistor Lead Configuration. Fig. 4-3 shows the lead configurations of the transistors and nuvistors used in this instrument. This view is as seen from the bottom of the transistor or nuvistor.

Troubleshooting Equipment

The following equipment is useful for troubleshooting the Type 454.

1. Transistor Tester

Description: Tektronix Type 575 Transistor-Curve Tracer or equivalent.

Purpose: To test the semiconductors used in this instrument.

2. Multimeter

Description VTVM, 10 megohm input impedance and 0 to 500 volts range; ohmmeter, 0 to 20 megohms. Accuracy, within 3%. Test prods must be well insulated to prevent accidental shorting.

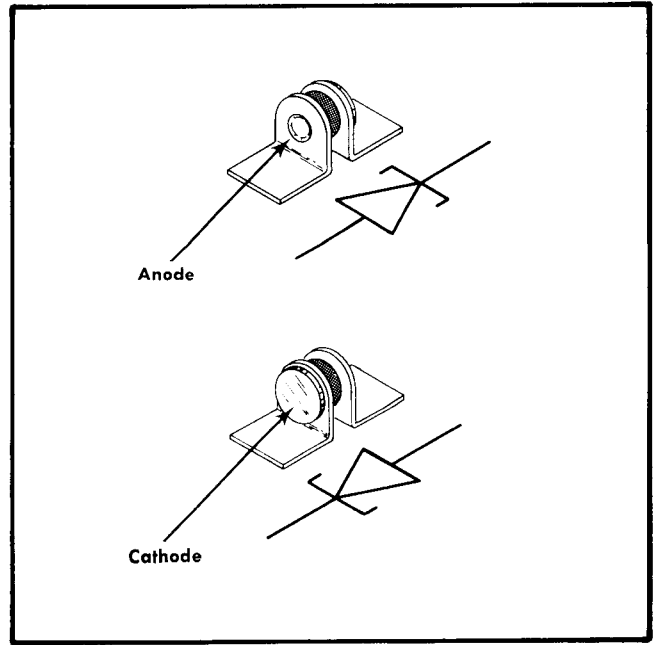

Fig. 4-2. Electrode configuration of strip-line tunnel diodes.

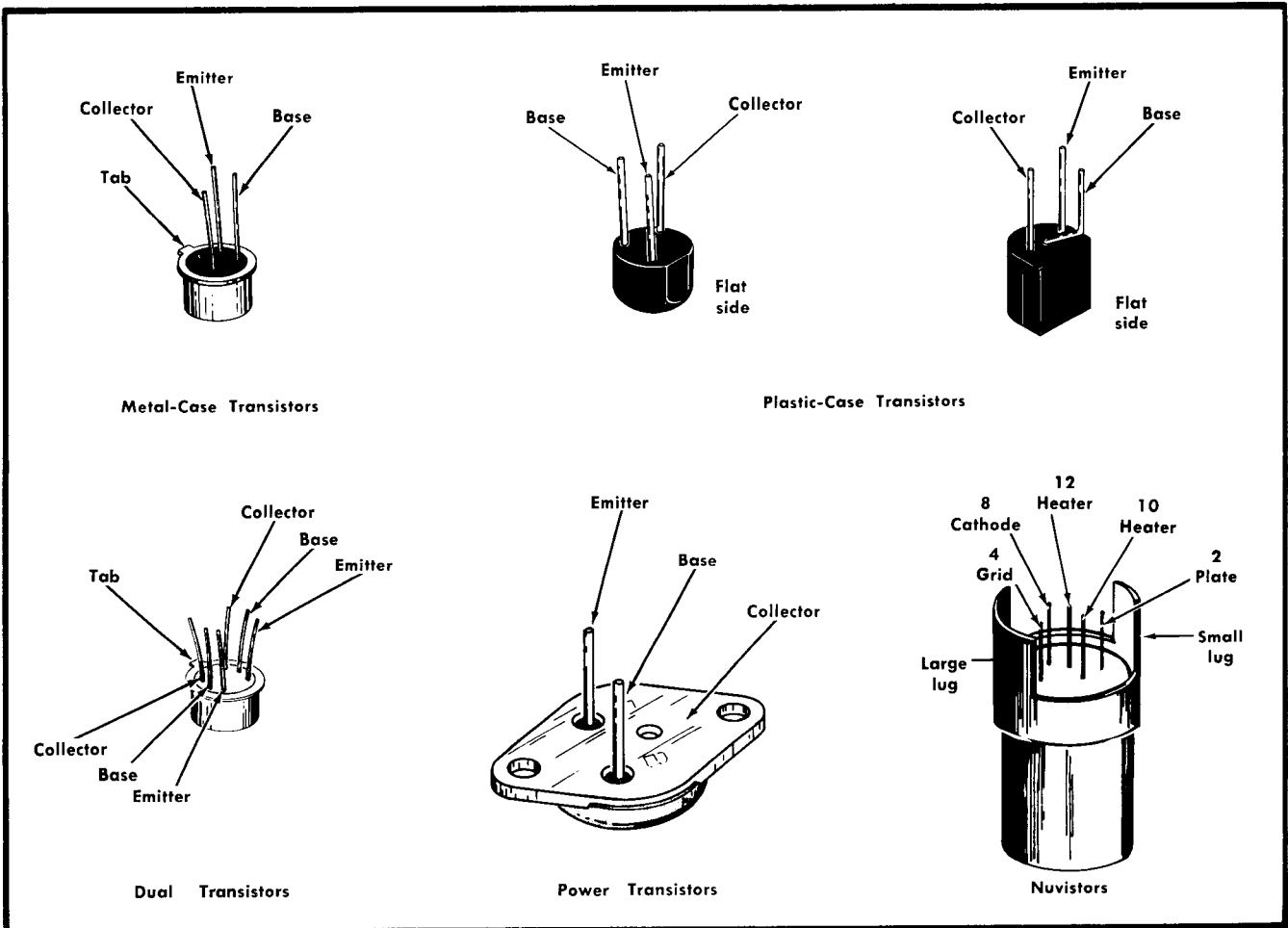

Fig. 4-3. Electrode configuration for transistors and nuvistors in this instrument (as viewed from bottom).

Purpose: To check voltages and for general troubleshooting in this instrument.

NOTE

A 20,000 ohms/volt VOM can be used to check the voltages in this instrument if allowances are made for the circuit loading of the VOM at high-impedance points.

3. Test Oscilloscope

Description: DC to 50 MHz frequency response, 5 millivolts to 10 volts/division deflection factor. A 10× probe should be used to reduce circuit loading.

Purpose: To check waveforms in this instrument.

Troubleshooting Techniques

This troubleshooting procedure is arranged in an order which checks the simple trouble possibilities before proceeding with extensive troubleshooting. The first few checks assure proper connection, operation and calibration. If the trouble is not located by these checks, the remaining steps aid in locating the defective component. When the defective component is located, it should be replaced following the replacement procedure given under Corrective Maintenance.

1. Check Control Settings. Incorrect control settings can indicate a trouble that does not exist. If there is any question about the correct function or operation of any control, see the Operating Instructions section of this manual.

2. Check Associated Equipment. Before proceeding with troubleshooting of the Type 454, check that the equipment used with this instrument is operating correctly. Check that the signal is properly connected and that the interconnecting cables are not defective. Also, check the power source.

3. Check Instrument Calibration. Check the calibration of this instrument, or the affected circuit if the trouble exists in one circuit. The apparent trouble may only be a result of misadjustment or may be corrected by calibration. Complete calibration instructions are given in the Calibration section of this manual.

4. Visual Check. Visually check the portion of the instrument in which the trouble is located. Many troubles can be located by visual indications such as unsoldered connections, broken wires, damaged circuit boards, damaged components, etc.

5. Isolate Trouble to a Circuit. To isolate a trouble to a circuit, note the trouble symptom. The symptom often identifies the circuit in which the trouble is located. For example, poor focus indicates that the CRT circuit (includes high voltage) is probably at fault. When trouble symptoms appear in more than one circuit, check all the affected circuits by taking voltage and waveform readings. Also check for the correct output signals at the output connectors with a test oscilloscope. If the signal is correct, the circuit is working correctly up to that point. For example, correct sawtooth output at the A SWEEP connector indicates that the A Trigger Generator and A Sweep Generator circuits are operating correctly.

Incorrect operation of all circuits often indicates trouble in the power supply. Check first for correct voltage of the individual supplies. However, a defective component else-

where in the instrument can appear as a power-supply trouble and may also affect the operation of other circuits. A short circuit in any regulated supply causes the output level of all supplies in this instrument to drop to zero until the short is removed. A short in the +150-volt unregulated supply causes the output of the regulated supplies to drop and also opens the 150 V fuse. If the output level of all the supplies is incorrect, check that the Line Voltage Selector Assembly is set for the correct line voltage and regulating range. Table 4-3 lists the tolerances of the power supplies in this instrument. If a power-supply voltage is within the listed tolerance, the supply can be assumed to be working correctly. If outside the tolerance, the supply may be misadjusted or operating incorrectly. Use the procedure given in the Calibration section to adjust the power supplies.

TABLE 4-3
Power Supply Tolerance

| Power Supply | Tolerance | Typical Ripple (maximum) |
|--------------|-------------------------------------|--------------------------|
| −1960 volt | ±58.8 volts | |
| −12 volt | ±0.12 volt | 2 millivolts |
| +12 volt | 12.1 volts, ±0.21 volt ¹ | 2 millivolts |
| +75 volt | ±0.75 volt | 2 millivolts |

Fig. 4-4 provides a guide to aid in locating a defective circuit. This chart may not include checks for all possible defects; use steps 6-8 in such cases. Start from the top of the chart and perform the given checks on the left side of the page until a step is found which does not produce indicated results. Further checks and/or the circuit in which the trouble is probably located are listed to the right of this step.

After the defective circuit has been located, proceed with steps 6 through 8 to locate the defective component(s).

6. Check Circuit Board Interconnections. After the trouble has been isolated to a particular circuit, check the pin connectors on the circuit board for correct connection. Figs. 4-9 through 4-19 show the correct connections for each board.

The pin connectors used in this instrument also provide a convenient means of circuit isolation. For example, if the power supply is shorted, the defective circuit can be isolated by disconnecting the pin connectors at the boards until the shorting condition is removed.

7. Check Voltages and Waveforms. Often the defective component can be located by checking for the correct voltage or waveform in the circuit. Typical voltages and waveforms are given on the diagrams.

NOTE

Voltages and waveforms given on the diagrams are not absolute and may vary slightly between instruments. To obtain operating conditions similar to those used to take these readings, see the first diagram page.

¹Adjusted for correct output from the Calibrator circuit; see Calibration Procedure.

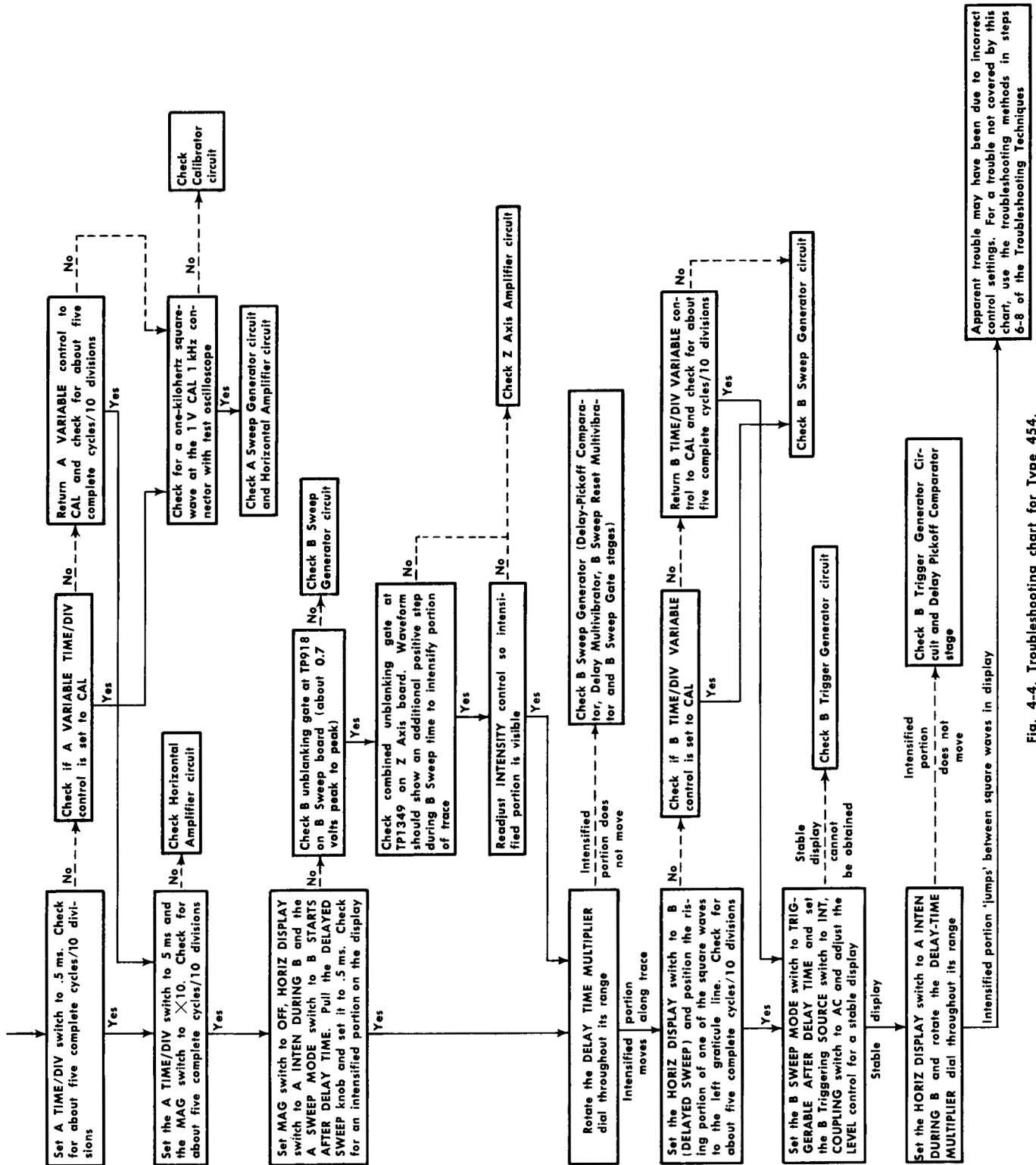

Fig. 4-4. Troubleshooting chart for Type 454.

Maintenance—Type 454/R454

8. Check Individual Components. The following procedures describe methods of checking individual components in the Type 454. Components which are soldered in place are best checked by disconnecting one end. This isolates the measurement from the effects of surrounding circuitry.

A. TRANSISTORS AND NUVISTORS. The best check of transistor or nuvistor operation is actual performance under operating conditions. If a transistor or nuvistor is suspected of being defective, it can best be checked by substituting a new component or one which has been checked previously. However, be sure that circuit conditions are such that a replacement transistor or nuvistor might also be damaged. If substitute transistors or nuvistors are not available, use a dynamic tester (such as Tektronix Type 570 or 575). Static-type testers are not recommended, since they do not check operation under simulated operating conditions.

CAUTION

POWER switch must be turned off before removing or replacing transistors or nuvistors.

B. DIODES. A diode can be checked for an open or shorted condition by measuring the resistance between terminals. With an ohmmeter scale having an internal source of between 800 millivolts and 3 volts, the resistance should be very high in one direction and very low when the leads are reversed.

CAUTION

Do not use an ohmmeter scale that has a high internal current. High currents may damage the diode. Do not measure tunnel diodes with an ohmmeter; use a dynamic tester (such as a Tektronix Type 575 Transistor-Curve Tracer).

C. RESISTORS. Resistors can be checked with an ohmmeter. Check the Electrical Parts List for the tolerance of the resistors used in this instrument. Resistors normally do not need to be replaced unless the measured value varies widely from the specified value.

D. INDUCTORS. Check for open inductors by checking continuity with an ohmmeter. Shorted or partially shorted inductors can usually be found by checking the waveform response when high-frequency signals are passed through the circuit. Partial shorting often reduces high-frequency response (roll-off).

E. CAPACITORS. A leaky or shorted capacitor can best be detected by checking resistance with an ohmmeter on the highest scale. Do not exceed the voltage rating of the capacitor. The resistance reading should be high after initial charge of the capacitor. An open capacitor can best be detected with a capacitance meter or by checking if the capacitor passes AC signals.

F. REED-DRIVE COIL. The reed-drive coil can be checked for correct operation as follows (the coil has four mounting leads for rigidity; make measurements between the two leads on either end of the coil): 1) Check the DC resistance of the coil with an ohmmeter; typical resistance values are given in the electrical parts list. 2) Check the DC voltage drop across the coil when the actuating level is applied.

3) If both the resistance and voltage are correct, the coil can be assumed to be correct; check the reed relay position and continuity. 4) If the resistance is incorrect (take into account surrounding circuitry), disconnect the coil and check the resistance again. 5) If the voltage across the coil is incorrect but the coil resistance is correct, check the circuit originating the actuating level.

9. Repair and Readjust the Circuit. If any defective parts are located, follow the replacement procedures given in this section. Be sure to check the performance of any circuit that has been repaired or that has had any electrical components replaced.

CORRECTIVE MAINTENANCE

General

Corrective maintenance consists of component replacement and instrument repair. Special techniques required to replace components in this instrument are given here.

Obtaining Replacement Parts

Standard Parts. All electrical and mechanical part replacements for the Type 454 can be obtained through your local Tektronix Field Office or representative. However, many of the standard electronic components can be obtained locally in less time than is required to order them from Tektronix, Inc. Before purchasing or ordering replacement parts, check the parts list for value, tolerance, rating and description.

NOTE

When selecting replacement parts, it is important to remember that the physical size and shape of a component may affect its performance in the instrument, particularly at high frequencies. All replacement parts should be direct replacements unless it is known that a different component will not adversely affect instrument performance.

Special Parts. In addition to the standard electronic components, some special parts are used in the Type 454. These parts are manufactured or selected by Tektronix, Inc. to meet specific performance requirements, or are manufactured for Tektronix, Inc. in accordance with our specifications. These special parts are indicated in the parts list by an asterisk preceding the part number. Most of the mechanical parts used in this instrument have been manufactured by Tektronix, Inc. Order all special parts directly from your local Tektronix Field Office or representative.

Ordering Parts. When ordering replacement parts from Tektronix, Inc., include the following information:

1. Instrument Type.
2. Instrument Serial Number.
3. A description of the part (if electrical, include circuit number).
4. Tektronix Part Number.

Soldering Techniques

WARNING

Disconnect the instrument from the power source before soldering.

Circuit Boards. Use ordinary 60/40 solder and a 35- to 40-watt pencil type soldering iron on the circuit boards. The tip of the iron should be clean and properly tinned for best heat transfer to the solder joint. A higher wattage soldering iron may separate the wiring from the base material.

The following technique should be used to replace a component on a circuit board. Most components can be replaced without removing the boards from the instrument.

1. Grip the component lead with long-nose pliers. Touch the soldering iron to the lead at the solder connection. Do not lay the iron directly on the board, as it may damage the board.

2. When the solder begins to melt, pull the lead out gently. This should leave a clean hole in the board. If not, the hole can be cleaned by reheating the solder and placing a sharp object such as a toothpick into the hole to clean it out. A vacuum-type desoldering tool can also be used for this purpose.

3. Bend the leads of the new component to fit the holes in the board. If the component is replaced while the board is mounted in the instrument, cut the leads so they will just protrude through the board. Insert the leads into the holes in the board so the component is firmly seated against the board (or as positioned originally). If it does not seat properly, heat the solder and gently press the component into place.

4. Touch the iron to the connection and apply a small amount of solder to make a firm solder joint. To protect heat-sensitive components, hold the lead between the component body and the solder joint with a pair of long-nose pliers or other heat sink.

CAUTION

Special precautions must be taken when unsoldering or resoldering the strip-line tunnel diodes which are soldered directly to the surface of the circuit board. Use a 15-watt pencil type soldering iron and apply only enough heat to remove or make the connection. Grip the tunnel diode gently with a pair of long-nose pliers to protect the junction from overheating. Fig. 4-2 identifies the anode and cathode of these tunnel diodes.

5. Clip the excess lead that protrudes through the board (if not clipped in step 3).

6. Clean the area around the solder connection with a flux-remover solvent. Be careful not to remove information printed on the board.

Ceramic Terminal Strips. Solder used on the ceramic terminal strips should contain about 3% silver. Use a 40- to 75-watt soldering iron with a 1/8-inch wide wedge-shaped tip. Ordinary solder can be used occasionally without damage to the ceramic terminal strips. However, if ordinary

solder is used repeatedly or if excessive heat is applied, the solder-to-ceramic bond may be broken.

A sample roll of solder containing about 3% silver is mounted on the rear subpanel of this instrument. Additional solder of the same type should be available locally, or it can be purchased from Tektronix, Inc. in one-pound rolls; order by Tektronix Part No. 251-0514-00.

Observe the following precautions when soldering to ceramic terminal strips.

1. Use a hot iron for a short time. Apply only enough heat to make the solder flow freely.

2. Maintain a clean, properly tinned tip.

3. Avoid putting pressure on the ceramic terminal strip.

4. Do not attempt to fill the terminal-strip notch with solder; use only enough solder to cover the wires adequately.

5. Clean the flux from the terminal strip with a flux-remover solvent.

Metal Terminals. When soldering metal terminals (e.g., switch terminals, potentiometers, etc.), ordinary 60/40 solder can be used. Use a soldering iron with a 40- to 75-watt rating and a 1/8-inch wide wedge-shaped tip.

Observe the following precautions when soldering metal terminals:

1. Apply only enough heat to make the solder flow freely.

2. Apply only enough solder to form a solid connection. Excess solder may impair the function of the part.

3. If a wire extends beyond the solder joint, clip off the excess.

4. Clean the flux from the solder joint with a flux-remover solvent.

Component Replacement

WARNING

Disconnect the instrument from the power source before replacing components.

Removing the Rear Panel. The rear panel must be removed for access to the rear subpanel. This panel can be removed by removing the Z Axis ground strap and the screws located around the edges of the rear panel.

Swing-Out Chassis. Some of the controls and connectors are mounted on a swing-out chassis on the right side of this instrument. The Calibrator circuit board is also mounted on the rear of this chassis. To reach the rear of this chassis or the components mounted behind it, first remove the top cover from the instrument. Then loosen the captive securing screw so the chassis can swing outward.

Ceramic Terminal Strip Replacement. A complete ceramic terminal strip assembly is shown in Fig. 4-5. Replacement strips (including studs) and spacers are supplied under separate part numbers. However, the old spacers may be re-used if they are not damaged. The applicable Tektronix Part Numbers for the ceramic strips and spacers used in this instrument are given in the Mechanical Parts List.

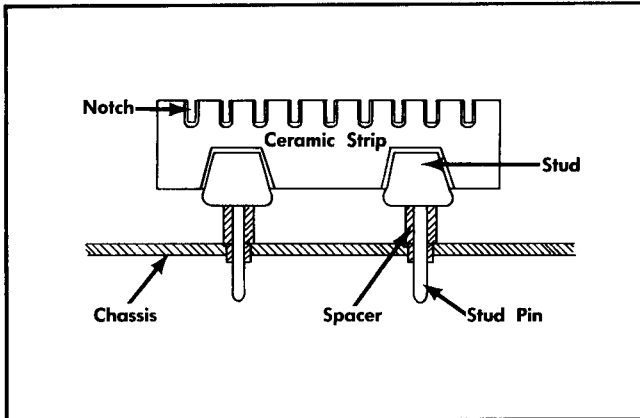

Fig. 4-5. Ceramic terminal strip assembly.

To replace a ceramic terminal strip, use the following procedure.

REMOVAL:

1. Unsolder all components and connections on the strip. To aid in replacing the strip, it may be advisable to mark each lead or draw a sketch to show location of the components and connections.
2. Pry or pull the damaged strip from the chassis.
3. If the spacers come out with the strip, remove them from the stud pins for use on the new strip (spacers should be replaced if they are damaged).

REPLACEMENT:

1. Place the spacers in the chassis holes.
2. Carefully press the studs of the strip into the spacers until they are completely seated. If necessary, use a soft mallet and tap lightly, directly over the stud, to seat the strip completely.
3. If the stud extends through the spacers, cut off the excess.
4. Replace all components and connections. Observe the soldering precautions given under Soldering Techniques in this section.

Circuit Board Replacement. If a circuit board is damaged beyond repair, either the entire assembly including all soldered-on components, or the board only, can be replaced. Part numbers are given in the Mechanical Parts List for either the completely wired or the unwired board. Most of the components mounted on the circuit boards can be replaced without removing the boards from the instrument. Observe the soldering precautions given under Soldering Techniques in this section.

GENERAL:

Most of the connections to the circuit boards are made with pin connectors. However, several connections are soldered to the Vertical Output Amplifier and Vertical Pre-amp boards. See the special removal instructions to remove these boards.

Use the following procedure to remove a circuit board.

1. Disconnect all pin connectors which come through holes in the board.
2. Remove all screws holding the board to the chassis.
3. The board may now be lifted for maintenance or access to areas beneath the board.
4. To completely remove the board, disconnect the remaining pin connectors.
5. Remove the cable clamps (if any) holding the cable to the board.
6. Lift the circuit board out of the instrument. Do not force or bend the board.
7. To replace the board, reverse the order of removal. Correct location of the pin connectors is shown in Figs. 4-9 through 4-19. Replace the pin connectors carefully so they mate correctly with the pins. If forced into place incorrectly positioned, the pin connectors may be damaged.

VERTICAL OUTPUT AMPLIFIER BOARD REMOVAL:

Use the following procedure to remove the Vertical Output Amplifier circuit board.

1. Unsolder the connections to the emitters of Q394 and Q494.
2. Disconnect the base leads of Q394 and Q494 from the sockets on the circuit board.
3. Remove the six screws holding the board to the chassis.
4. Unsolder the delay-line output connections.
5. Remove the bolt holding the delay-line clamp to the circuit board.
6. Disconnect all of the pin connectors.
7. Lift the circuit board out of the instrument.
8. To replace the board, reverse the order of removal. Correct location of the pin connectors is shown in Fig. 4-12. Replace the pin connectors carefully so they mate correctly with the pins. If forced into place incorrectly positioned, the pin connector may be damaged.

VERTICAL PREAMP UNIT REMOVAL:

Use the following procedure to remove the Vertical Pre-amp board and the attenuators as a unit.

1. Remove the screw (mounted with a washer) which holds the MODE-TRIGGER switch (rear of board) to the chassis. The other screw may be left in place.
2. Remove the two screws at the rear of the board.
3. Unsolder the delay-line input connections.
4. Remove the securing nut from the delay line.
5. Unsolder the three wires connected to each PROBE POWER connector. Note the color coding for reconnection.
6. Remove the four nuts located just inside the lower lip of the front casting at each side of the INPUT connectors.
7. Remove the VARIABLE, VOLTS/DIV, POSITION, Input Coupling, TRIGGER and MODE knobs.

8. Remove the securing nuts on the VOLTS/DIV switches.
9. Lift up on the rear of the assembly and slide it out of the instrument. The top side of the board and the attenuators can now be reached for troubleshooting.
10. The board may now be separated from the Vertical Preamp unit as follows:
 - a. Disconnect all pin connectors.
 - b. Remove the cable clamp from the board.
 - c. Unsolder all connections on the rear side of the board which connect between the attenuators and the board. Observe the soldering precautions given in this section.
 - d. Remove the remaining screw which holds the MODE-TRIGGER switch to the board.
 - e. Remove the four screws which hold the board to the attenuators.

11. To replace the unit, reverse the order of removal. Be sure the GAIN and INVERT extensions are positioned correctly in the corresponding front-panel holes. Correct location of the pin connectors is shown in Fig. 4-9 and 4-10.

Cathode-Ray Tube Replacement. Use care when handling a CRT. Protective clothing and safety glasses should be worn. Avoid striking it on any object which might cause it to crack or implode. When storing a CRT, place it face down on a smooth surface with a protective cover or soft mat under the faceplate to protect it from scratches. Do not bend the deflection-plate pins. If the pins are bent, the glass seal around the pins may be cracked, which allows the CRT to lose its vacuum.

The CRT shield should also be handled carefully. This shield protects the CRT display from distortion due to magnetic interference. If the shield is dropped or struck sharply, it may lose its shielding ability.

The following procedure outlines the removal and replacement of the cathode-ray tube:

REMOVAL:

1. Remove the top and bottom covers and rear panel as described previously.
2. Remove the light filter or faceplate protector.
3. Disconnect the CRT anode connector. Ground this lead and the anode connection to discharge any stored charge.
4. Unsolder the braided ground connection between the CRT shield and the Vertical Output Amplifier chassis.
5. Unsolder the y-axis rotation leads at the Y Axis Align control (on rear subpanel).
6. Carefully disconnect the deflection-plate connectors. Be careful not to bend the deflection-plate pins.
7. Remove the CRT socket.
8. Remove the two nuts (by the graticule lights) which hold the front of the CRT shield to the subpanel.
9. Remove the graticule lights from the studs and position them away from the shield.

10. Loosen the two hex-head screws inside the rear of the CRT shield. Remove the shield angle clamps and mounting screws.

11. Slide the CRT assembly to the rear of the instrument until the faceplate clears the mounting studs. Then lift the front of the CRT assembly up and unsolder the trace-rotation leads at the CRT shield (behind the Vertical Output amplifier chassis). Then slide the entire assembly out of the instrument.

12. Loosen the three screws on the CRT clamp inside the CRT shield. Do not remove the screws.

13. Hold the left hand on the CRT faceplate and push forward on the CRT base with the right hand. As the CRT starts out of the shield, grasp it firmly with the left hand. When the CRT is free of the clamp, slide the shield completely off the CRT. Be careful that the neck pins do not catch on the trace rotation coil or other obstructions and bend.

REPLACEMENT:

1. Insert the CRT into the shield. Be careful not to bend the neck pins. Seat the CRT firmly against the shield.
2. Tighten the bottom clamp screw inside the CRT shield. Recommended tightening torque: 4 to 7 inch-lbs. Do not tighten the screws on the sides.
3. Place the light mask over the CRT faceplate.
4. Using a method similar to that for removal (step 11) reinsert the CRT assembly into the instrument. Resolder the trace-rotation leads. Be sure the CRT faceplate seats properly against the subpanel.
5. Tighten the two remaining screws on the inside of the CRT shield.
6. Replace the shield angle clamps and mounting screws on the rear sub-panel. Tighten the two hex-head screws inside the rear of the CRT shield.
7. Replace the graticule lights and securing nuts.
8. Replace the CRT socket.
9. Reconnect the anode connector. Align the jack on the CRT and plug in the connector and press firmly on the insulated cover to snap the plug into place.
10. Reconnect the y-axis leads and the braided ground connection between the CRT shield and Vertical Output Amplifier chassis.
11. Carefully reconnect the deflection-plate connectors. Correct location is indicated on the CRT shield.
12. Check the calibration of the High Voltage, TRACE ROTATION, ASTIG, Y-Axis Align and Geometry adjustments. Adjustment procedure is given in the Calibration section.

Transistor and Nuvistor Replacement. Transistors and nuvistors should not be replaced unless they are actually defective. If removed from their sockets during routine maintenance, return them to their original sockets. Unnecessary replacement of transistors or nuvistors may affect the calibration of this instrument. When transistors or nuvistors are replaced, check the operation of that part of the instrument which may be affected.

CAUTION

POWER switch must be turned off before removing or replacing transistors or nuvistors.

Replacement transistors or nuvistors should be of the original type or a direct replacement. Fig. 4-3 shows the lead configuration of the transistors and nuvistors used in this instrument. Some plastic case transistors have lead configurations which do not agree with those shown here. If a transistor is replaced by a transistor which is made by a different manufacturer than the original, check the manufacturer's basing diagram for correct basing. All transistor sockets in this instrument are wired for the basing used for metal-case transistors. The transistor sockets on the Vertical Output Amplifier circuit board have individual sockets for each lead. These sockets are placed in the board in the standard lead configuration. Transistors which have heat radiators or are mounted on the chassis use silicone grease to increase heat transfer. Replace the silicone grease when replacing these transistors.

WARNING

Handle silicone grease with care. Avoid getting silicone grease in the eyes. Wash hands thoroughly after use.

Fuse Replacement. The power-line fuses are located on the rear panel in the Voltage Selector Assembly. Power-supply fuses are located beside the power transformer. Table 4-4 gives the value and locations of the fuses used in this instrument.

TABLE 4-4
Fuse Ratings

| Circuit Number | Rating | Location | Function |
|----------------|------------|---------------------------|---------------|
| F1101 | 2A Fast | Voltage Selector Assembly | 115-volt line |
| F1102 | 1A Fast | Voltage Selector Assembly | 230-volt line |
| F1204 | 0.25A Fast | By power transformer | +150 volts |
| F1437 | 2A Fast | By power transformer | High voltage |

Glass Reed-Relay Replacement. The glass reed-relay used in this instrument is pressurized. Therefore, safety glasses should be worn to protect the eyes when replacing this relay. To avoid damage to the reed-relay, do not apply stress to the metal-glass bond. When it is necessary to bend a lead, use two pair of long-nose pliers. Before replacing a reed-relay, be sure the actuating circuitry is not at fault. See the Troubleshooting procedure for methods of checking the circuit. It is important that the replacement reed-relay be correctly positioned within the drive-coil assembly with the same lead length as the original to provide similar magnetic characteristics.

REMOVAL:

1. Observe the physical position of the leads and glass bulb of the old reed-relay.

2. Unsolder the leads of the old reed-relay from the solder posts.

3. Pull the old reed-relay out of the drive-coil.

REPLACEMENT:

1. Slip the new reed-relay into the drive-coil.

2. Position the new reed-relay in exactly the same physical position as the old one.

3. Position the leads correctly and solder the new reed-relay to the solder posts. Avoid excessive heat on the reed-relay; use a heat sink on the leads if soldering close to the glass body.

4. Clip off the excess lead length beyond the solder posts. Do not clip the lead closer than 1/4 inch from the glass body.

Rotary Switches. Individual wafers or mechanical parts of rotary switches are normally not replaceable. If a switch is defective, replace the entire assembly. Replacement switches can be ordered either wired or unwired; refer to the Electrical Parts List for the applicable part numbers.

When replacing a switch, tag the leads and switch terminals with corresponding identification tags as the leads are disconnected. Then, use the old switch as a guide for installing the new one. An alternate method is to draw a sketch of the switch layout and record the wire color at each terminal. When soldering to the new switch, be careful that the solder does not flow beyond the rivets of the switch terminals. Spring tension of the switch contact can be destroyed by excessive solder.

The swing-out chassis on the right side of the instrument provides access to the side of the TIME/DIV and HORIZ DISPLAY switches. The top and bottom of these switches can be reached for easier repair or removal by removing the B Sweep board (top) or the A Sweep board (bottom).

Power Transformer Replacement. The power transformer in this instrument is warranted for the life of the instrument. If the power transformer becomes defective, contact your local Tektronix Field Office or representative for a warranty replacement (see the Warranty note in the front of this manual). Be sure to replace only with a direct replacement Tektronix transformer.

When removing the transformer, tag the leads with the corresponding terminal numbers to aid in connecting the new transformer. After the transformer is replaced, check the performance of the complete instrument using the Performance Check Procedure.

High Voltage Compartment. The components located in the high-voltage compartment can be reached for maintenance or replacement by using the following procedure.

1. Remove the bottom cover of the instrument as described in this section.

2. Remove the high-voltage shield by loosening the three screws securing it.

3. Remove the two screws which hold the plastic cover on the high-voltage compartment and remove the cover.

4. To remove the complete wiring assembly from the high-voltage compartment, remove the two screws which go

through the transformer. Be careful not to lose the heat-sink block beneath the high-voltage transformer. Also remove the plastic screw on the other end of the high-voltage compartment. Now, unsolder the post-deflection anode lead (heavily insulated lead at the side of the compartment). The other leads are long enough to allow the assembly to be lifted out of the compartment to reach the parts on the under side.

5. To replace the high-voltage compartment, reverse the order of removal.

NOTE

All solder joints in the high-voltage compartment should have smooth surfaces. Any protrusions may cause high-voltage arcing at high altitudes.

Power Chassis. The power transistors and other heat dissipating power-supply components are mounted below the Low-Voltage Regulator board. Remove the Low-Voltage Regulator board to reach these components. To reach the underside of the chassis, remove the fan through the rear subpanel.

Recalibration After Repair

After any electrical component has been replaced, the calibration of that particular circuit should be checked, as well as the calibration of other closely related circuits. Since the low-voltage supply affects all circuits, calibration of the entire instrument should be checked if work has been done in the low-voltage supply or if the power transformer has been replaced. The Performance Check Procedure in Section 5 provides a quick and convenient means of checking instrument operation.

Instrument Repackaging

If the Type 454 is to be shipped for long distances by commercial means of transportation, it is recommended that the instrument be repackaged in the original manner for maximum protection. The original shipping carton can be saved and used for this purpose. Fig. 4-6 illustrates how to repack the Type 454 and gives the part numbers for the packaging components if new items are needed. Fig. 4-7 illustrates how to repack the Type R454 and the applicable part numbers.

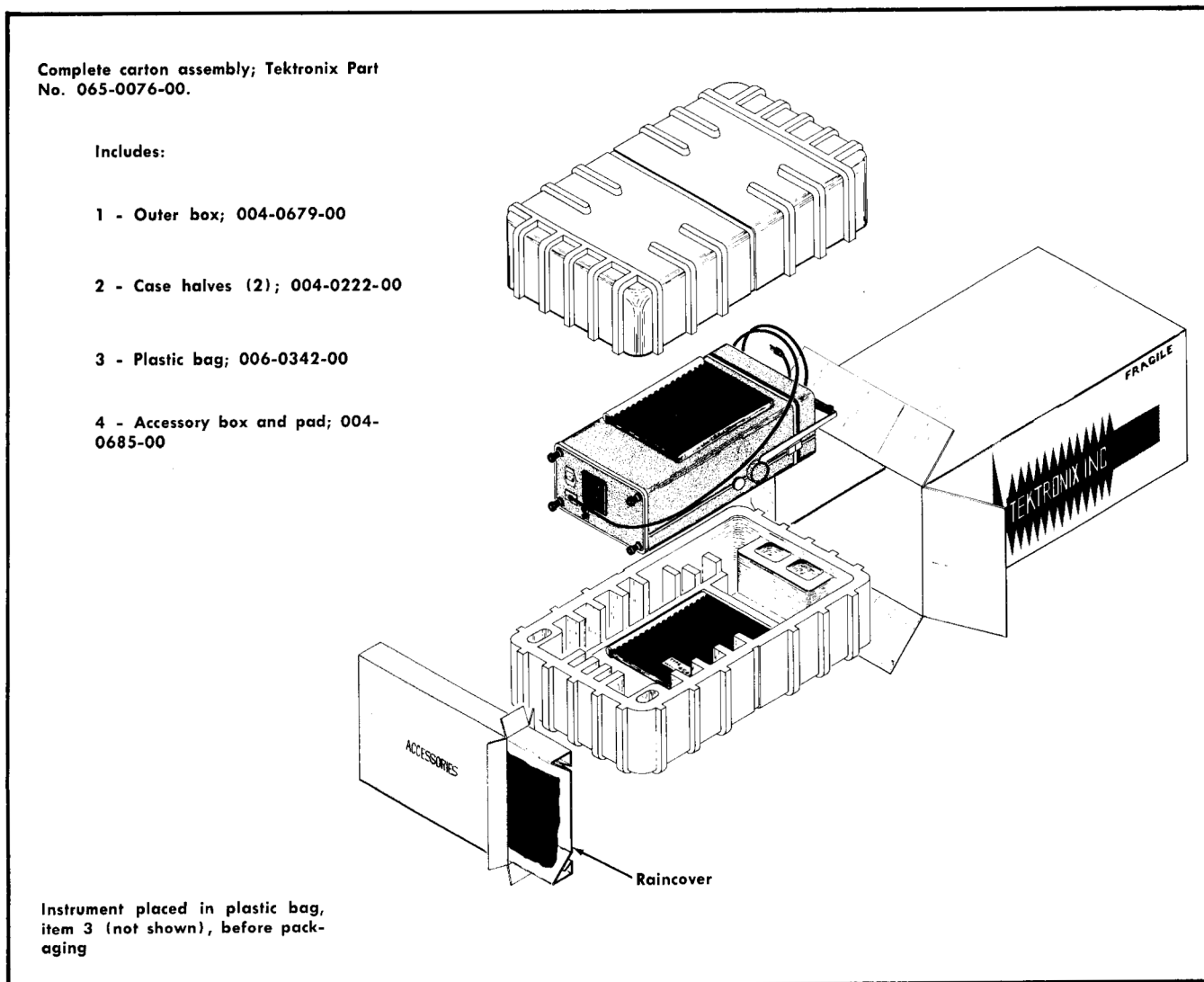

Fig. 4-6. Repackaging the Type 454 for shipment.

Maintenance—Type 454/R454

Complete carton assembly; Tektronix Part No. 065-0101-00.

Includes:

- 1 - Inner box; 004-0460-00
- 2 - Inner pad set; 004-0359-00
- 3 - Side pad set; 004-0360-00
- 4 - Bottom pad; 004-0357-00
- 5 - Rear pad (2); 004-0556-00
- 6 - Outer box; 004-0461-00
- 7 - Accessories box; 004-0462-00
- 8 - Outer pad set; 004-0361-00

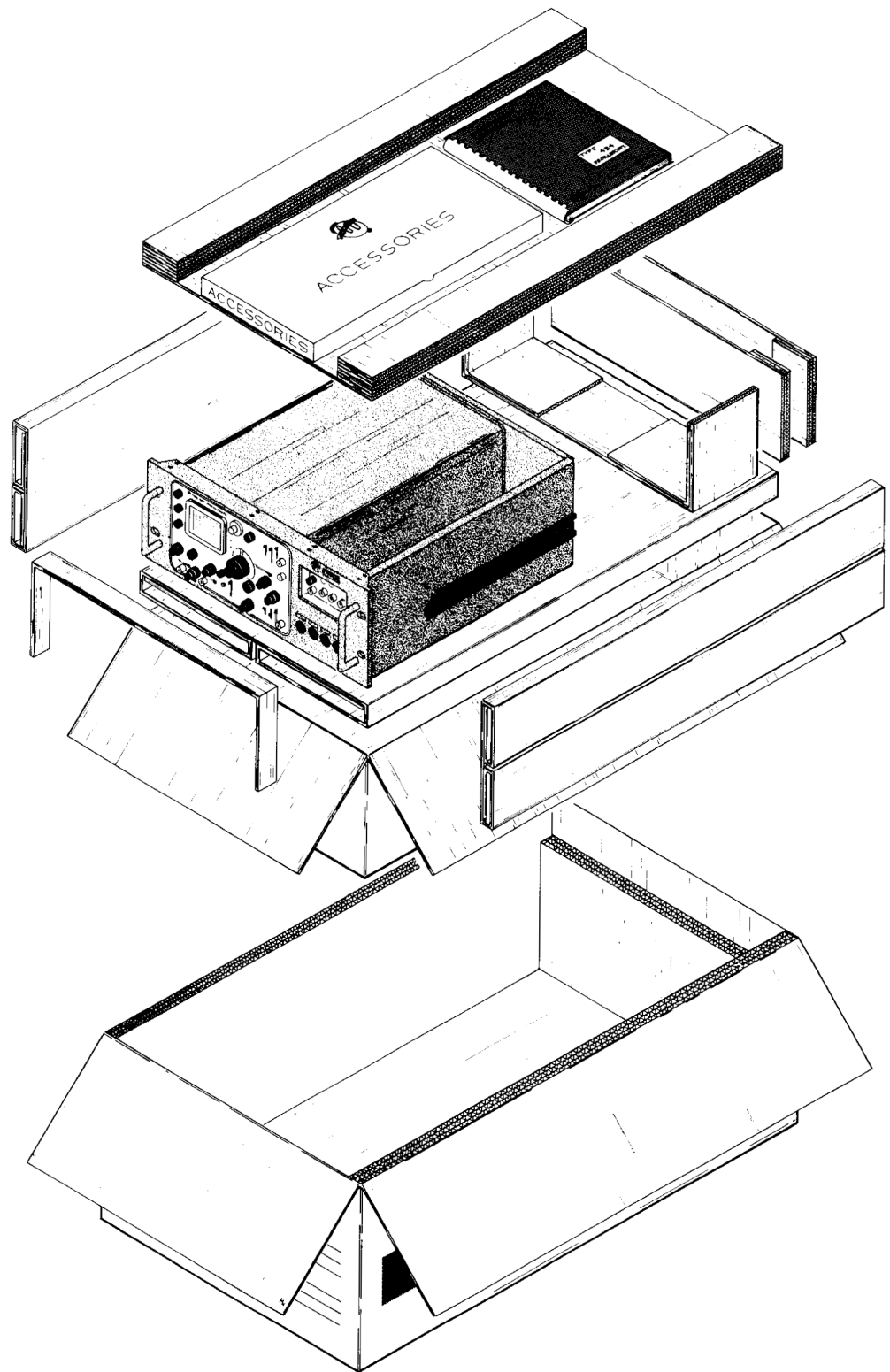

Fig. 4-7. Repackaging the Type R454 for shipment.

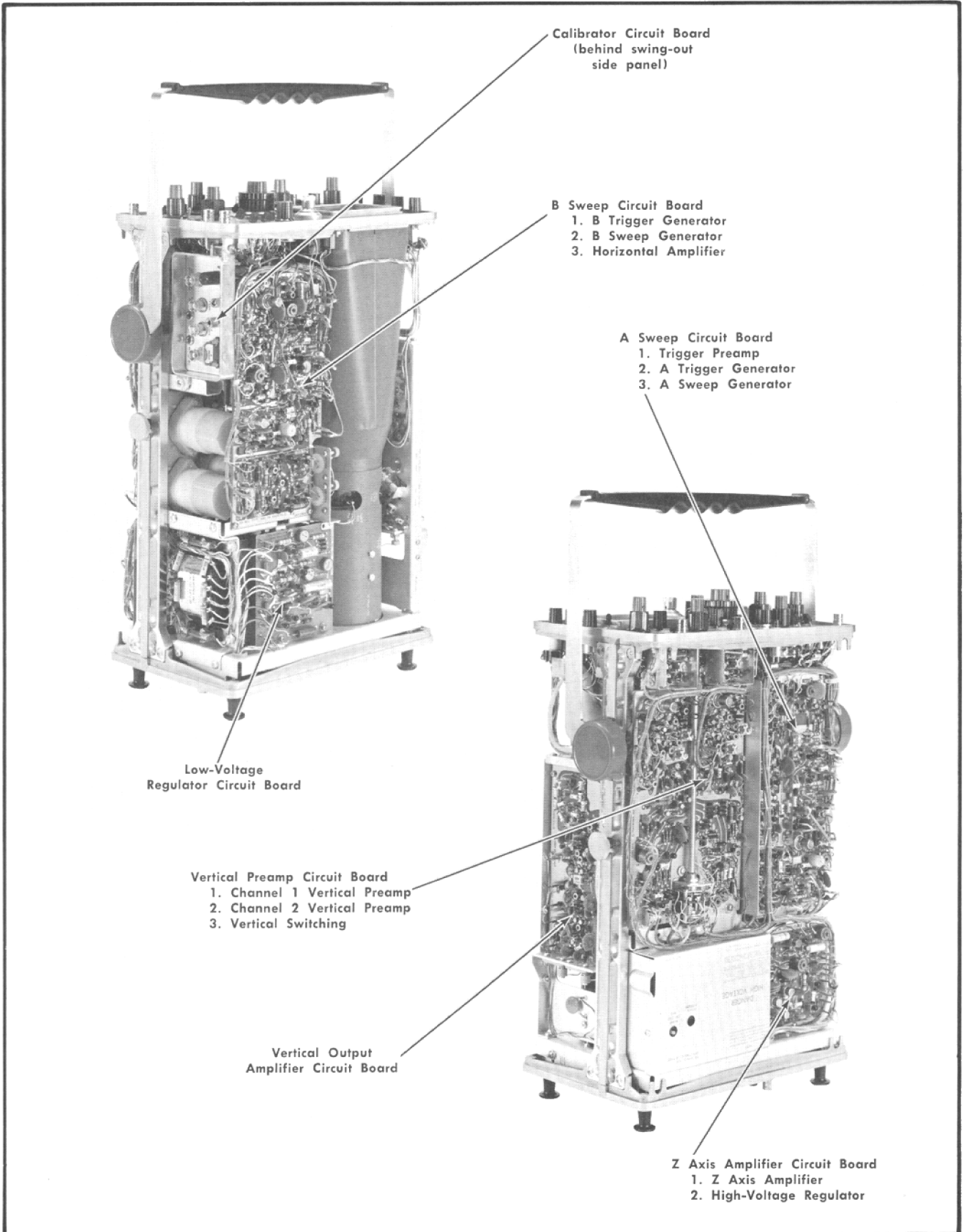

Fig. 4-8. Location of circuit boards in the Type 454.

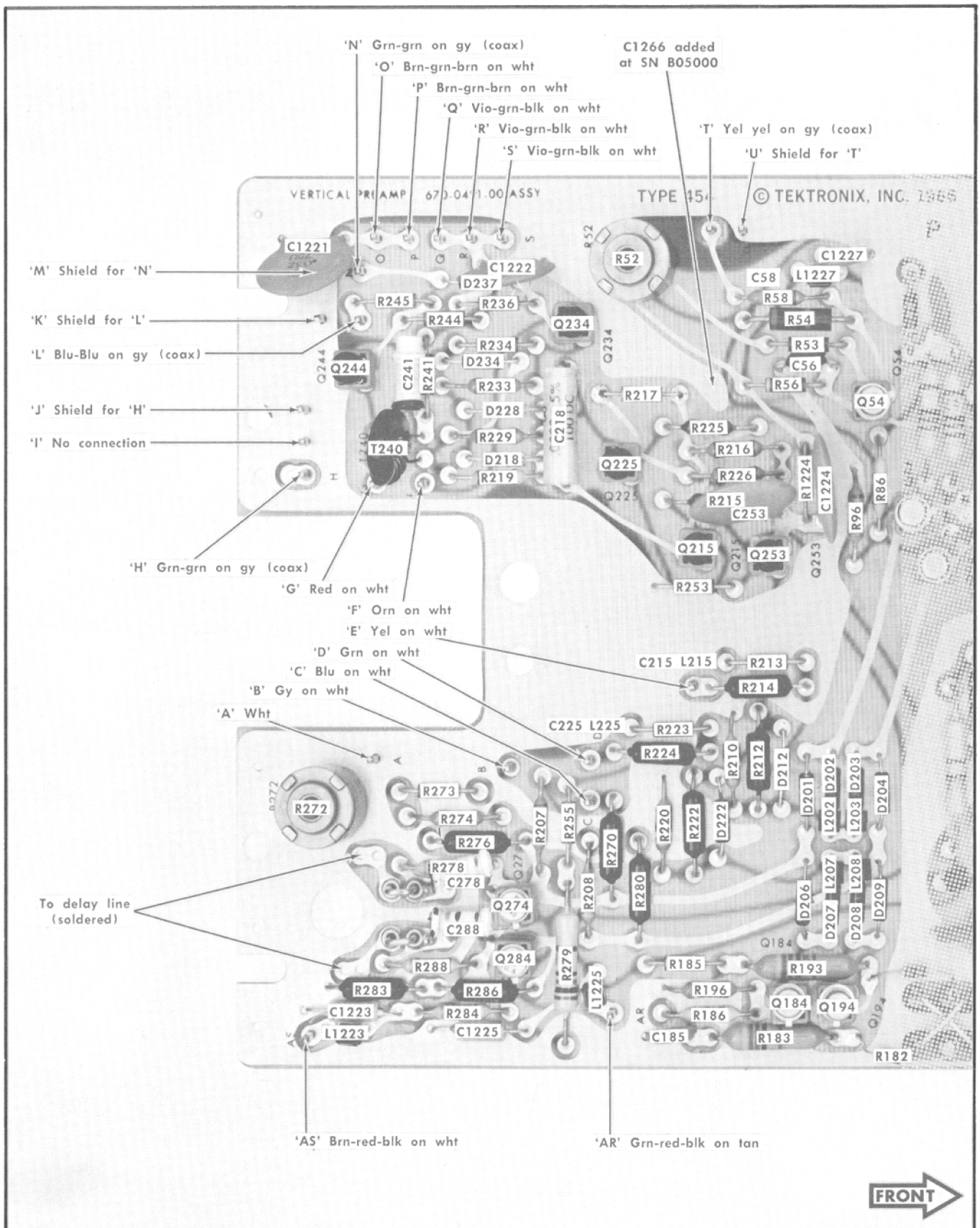

Fig. 4-9. Partial Vertical Preamp circuit board. Vertical Switching and partial Ch 1 and 2 Vertical Preamp circuits shown.

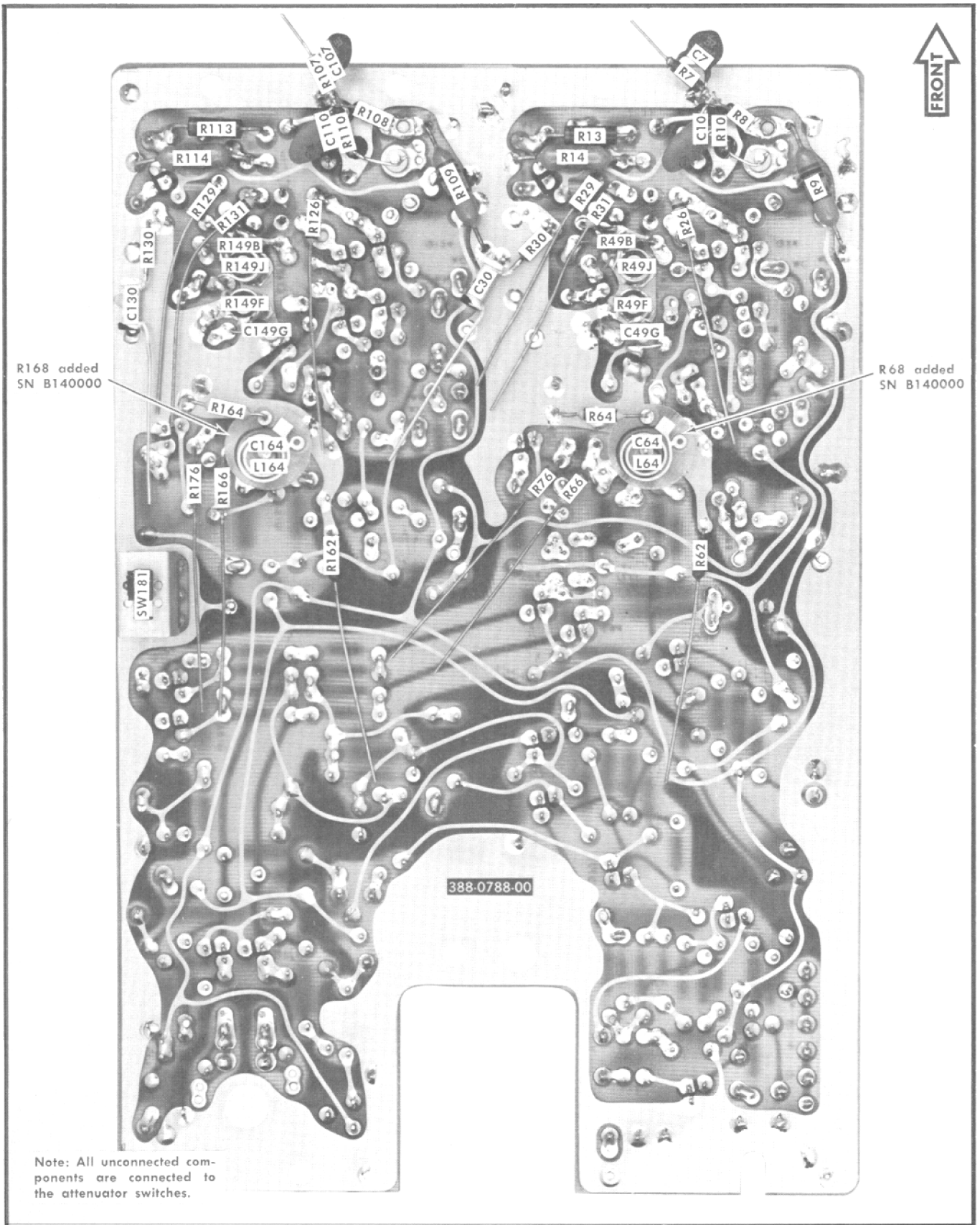

Fig. 4-11. Rear of Vertical Preamp circuit board (partial).

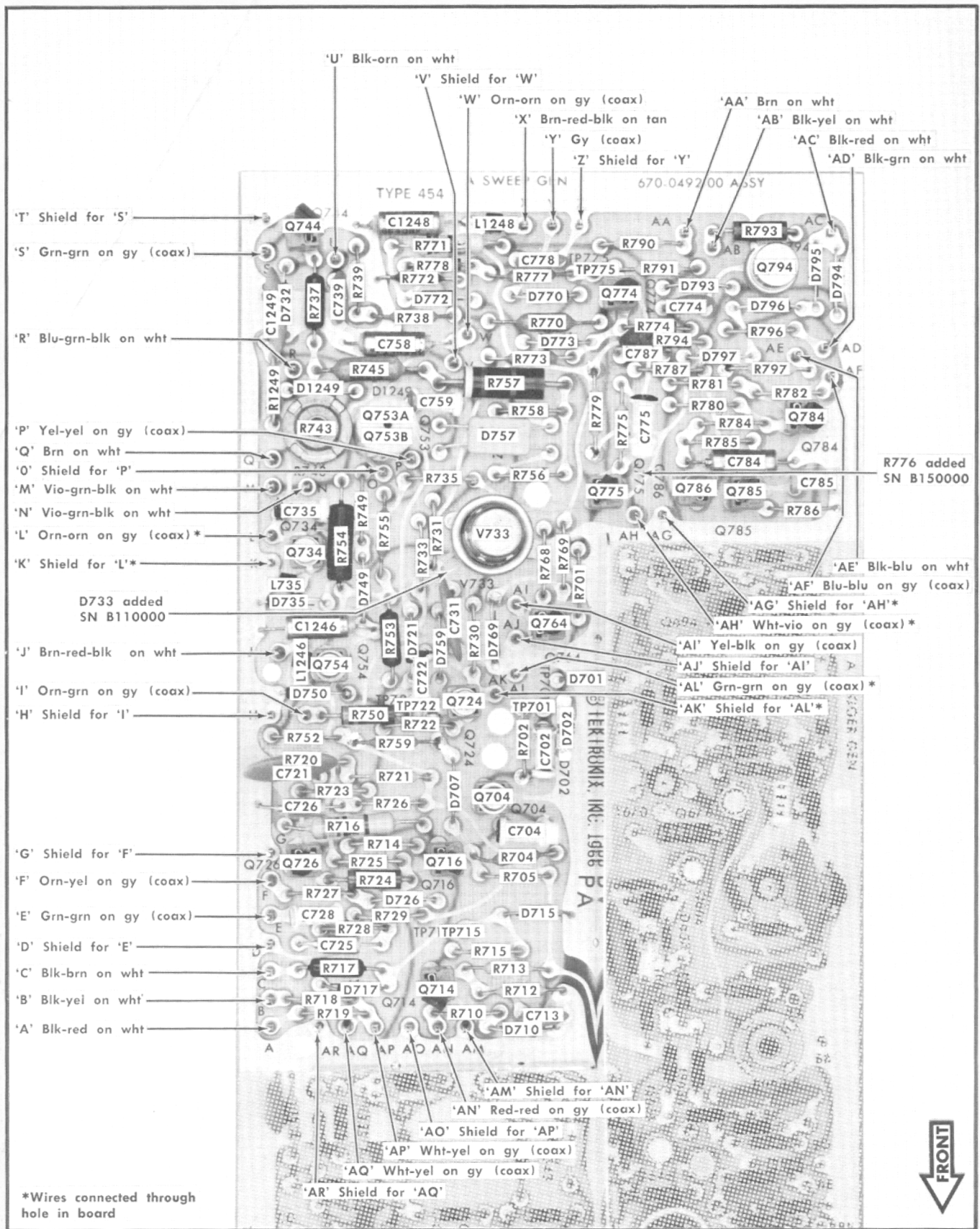

Fig. 4-13A. Partial A Sweep circuit board. (SN B010100 to B219999). A Sweep Generator circuit shown.

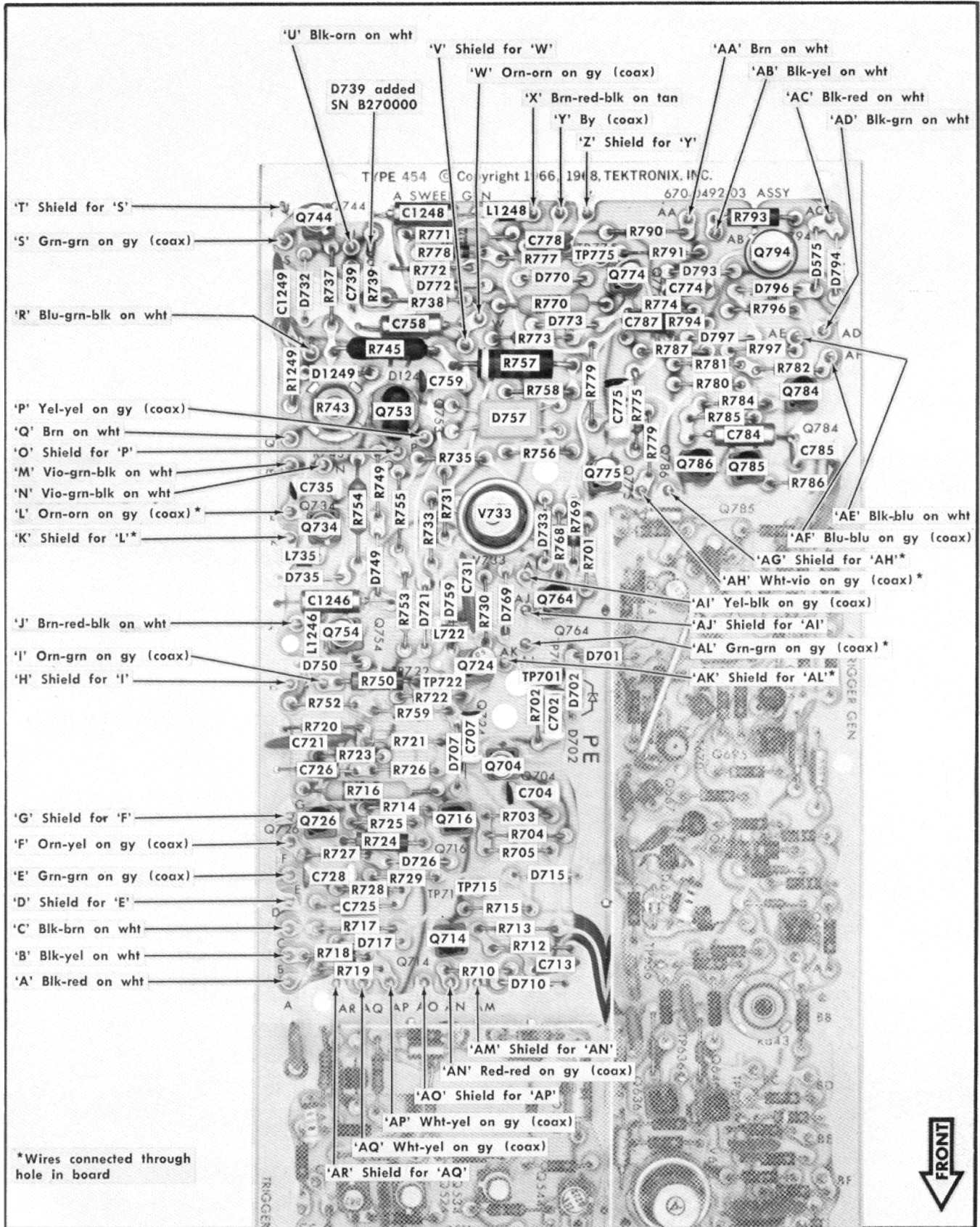

Fig. 4-13B. Partial A Sweep circuit board. (above SN B220000). A Sweep Generator circuit shown.

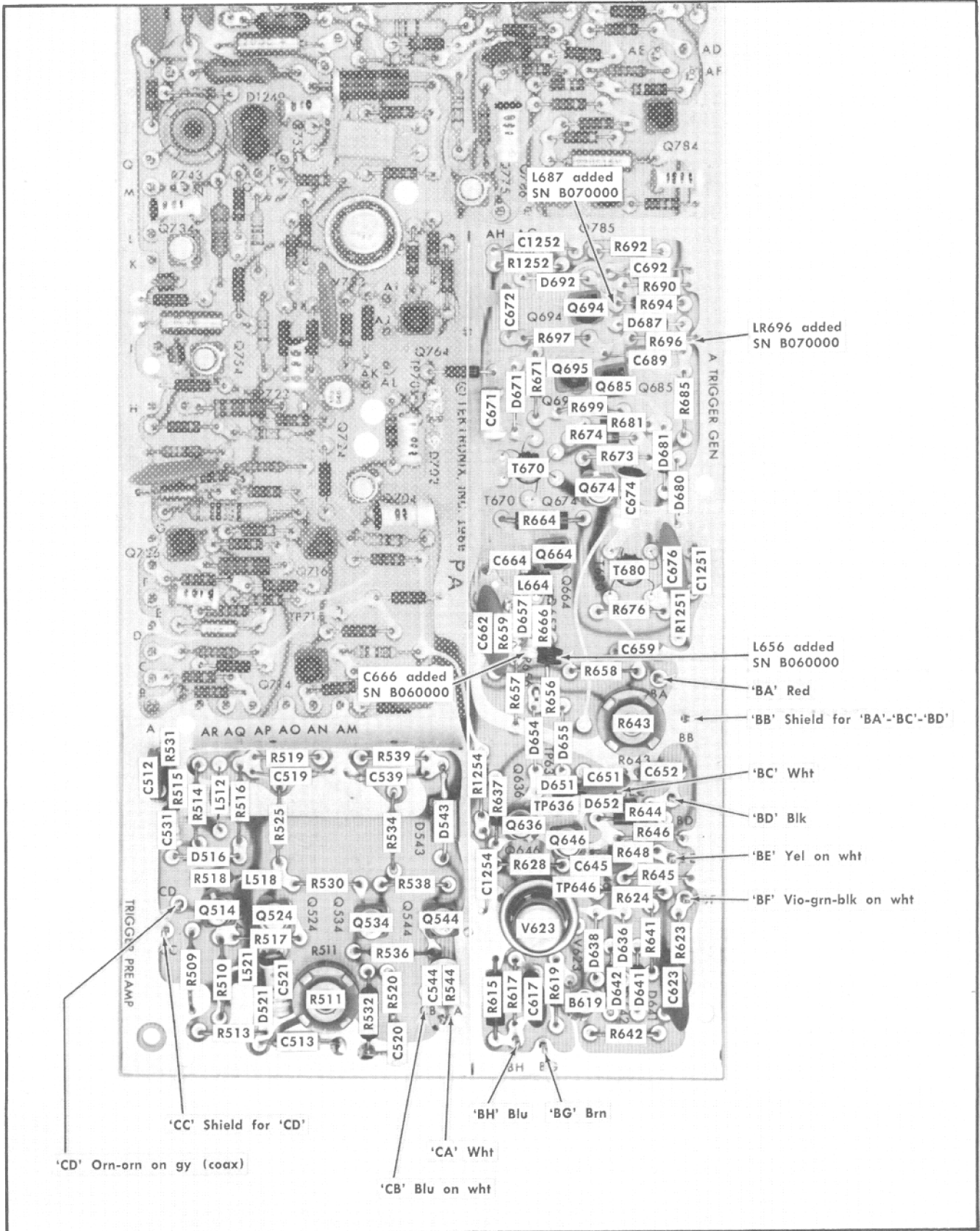

Fig. 4-14A. Partial A Sweep circuit board (SN B010100 to B219999). A Trigger Generator and Trigger Preamp circuit shown.

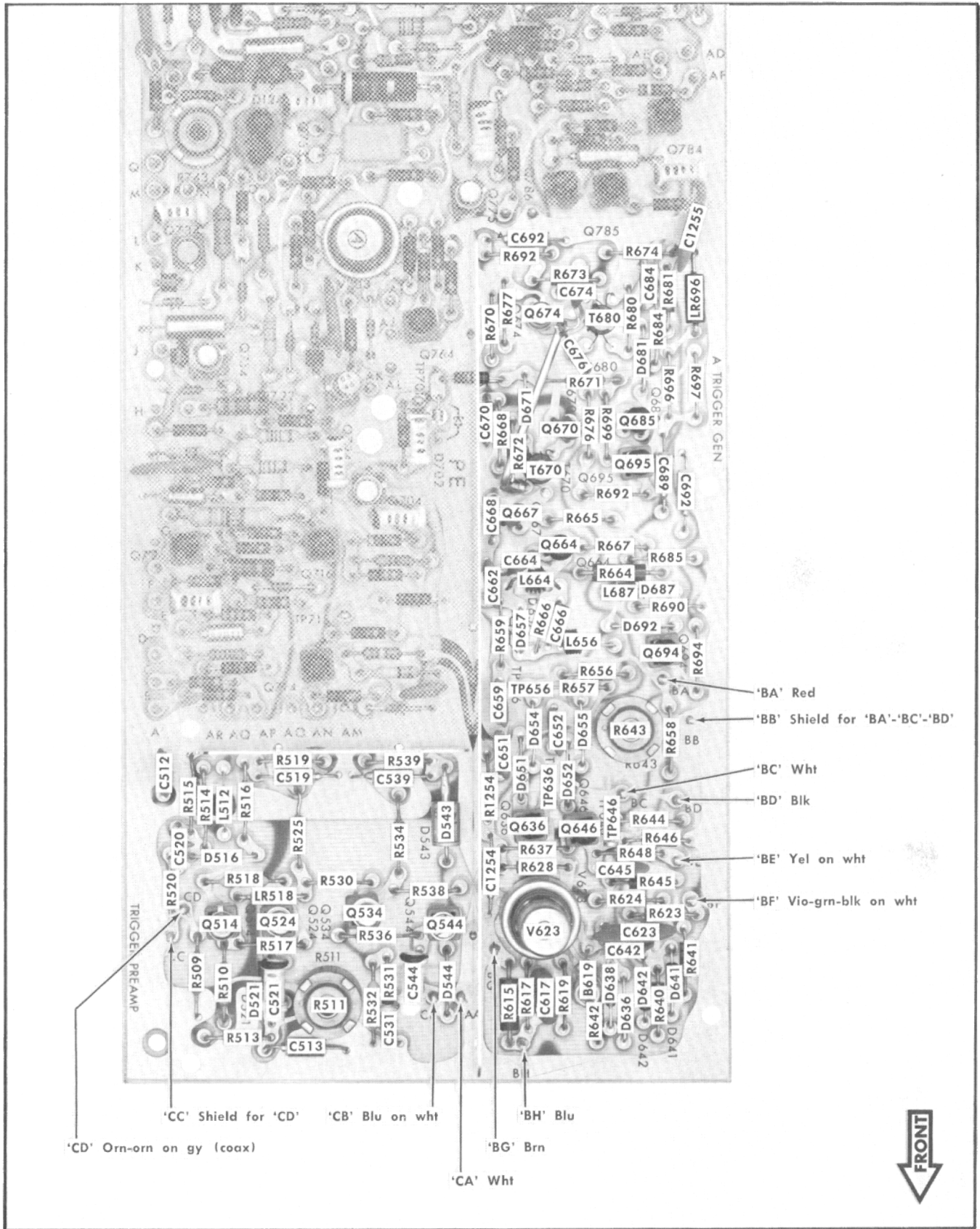

Fig. 4-14B. Partial A Sweep circuit board (SN B220000). A Trigger Generator and Trigger Preamp circuits shown.

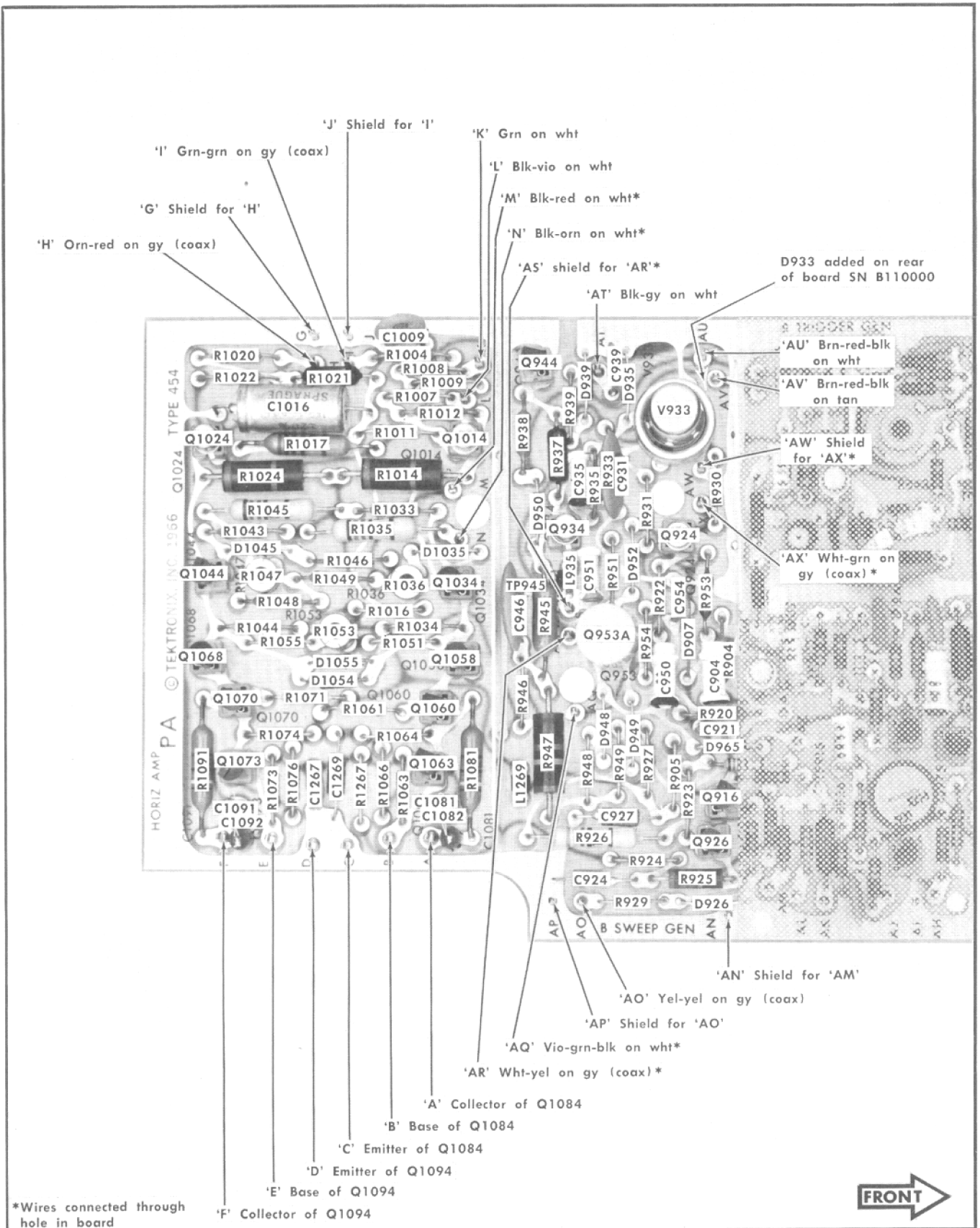

Fig. 4-15. Partial B Sweep circuit board. Horizontal Amplifier and partial B Sweep Generator circuits shown.

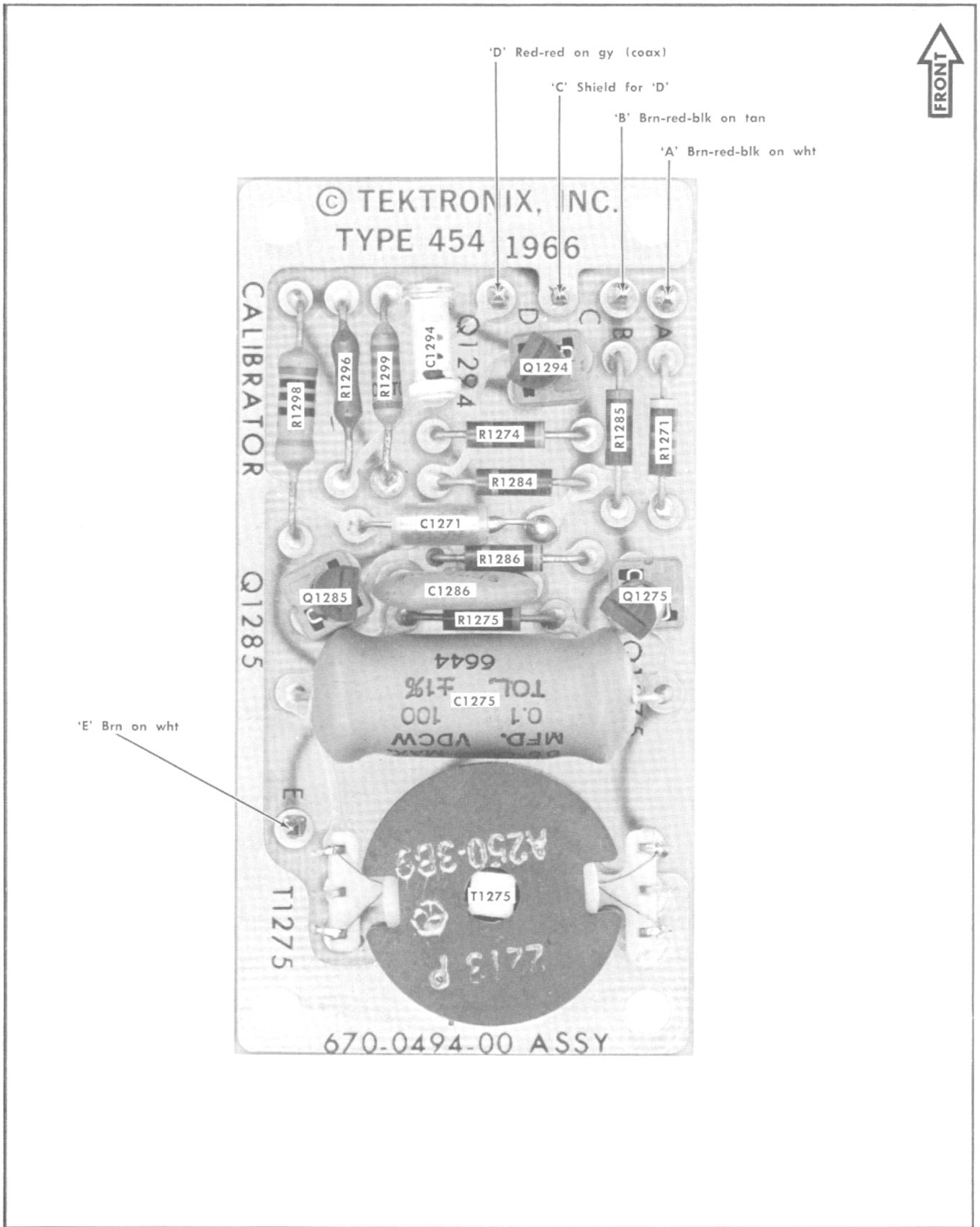

Fig. 4-18. Calibrator circuit board.

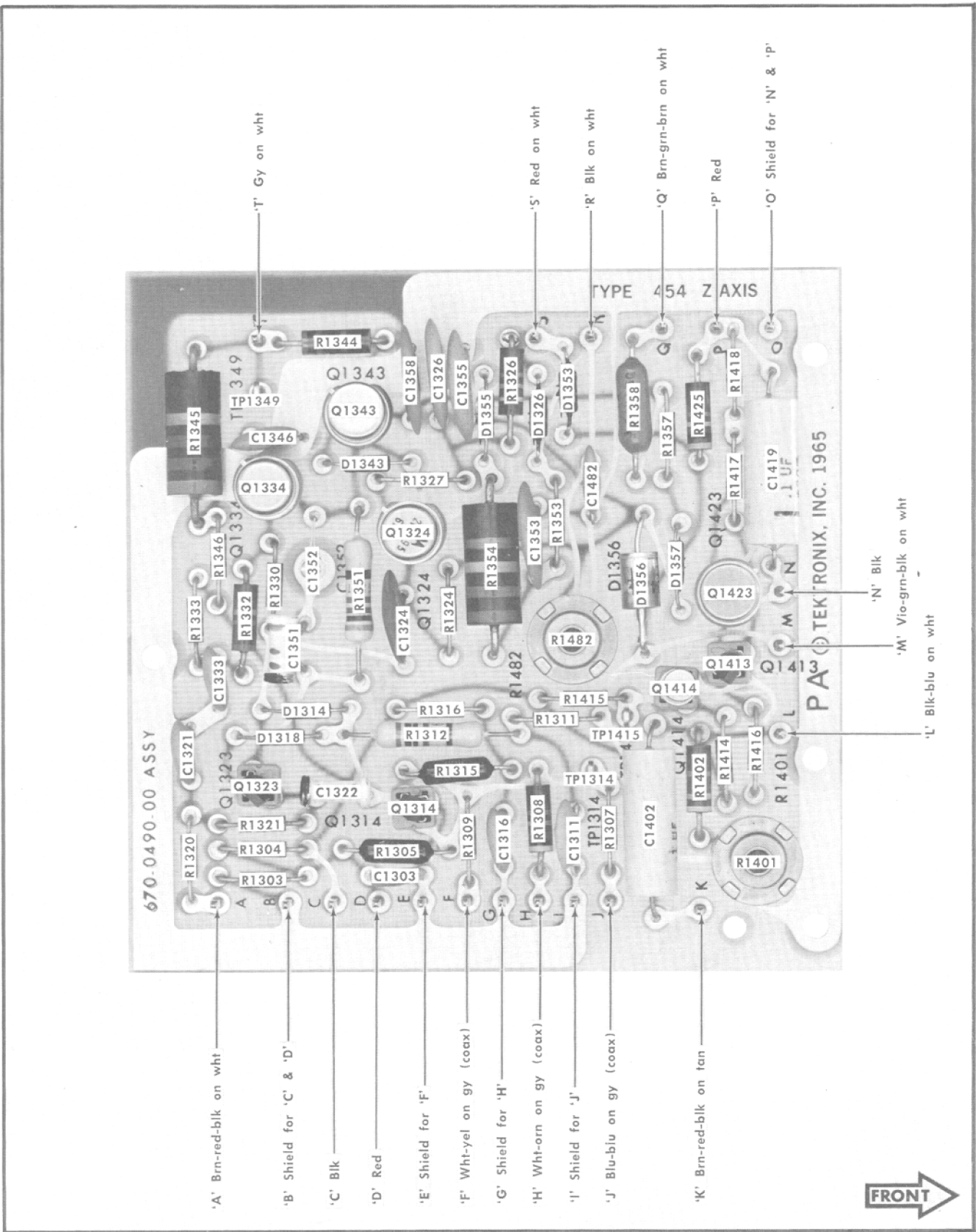

Fig. 4-19. Z Axis Amplifier circuit board. Z Axis Amplifier and High-Voltage Regulator circuits shown.

SECTION 5

PERFORMANCE CHECK

Introduction

This section of the manual provides a procedure for rapidly checking the performance of the Type 454. This procedure checks the operation of the instrument without removing the covers or making internal adjustments. However, screwdriver adjustments which are located on the front panel are adjusted in this procedure.

If the instrument does not meet the performance requirements given in this procedure, internal checks and/or adjustments are required. See the Calibration section. All performance requirements given in this section correspond to those given in Section 1 of this manual.

NOTE

All waveforms shown in this section are actual waveform photographs taken with a Tektronix Oscilloscope Camera System. Graticule lines have been photographically retouched.

Recommended Equipment

The following equipment is recommended for a complete performance check. Specifications given are the minimum necessary to perform this procedure. All equipment is assumed to be calibrated and operating within the given specifications. If equipment is substituted, it must meet or exceed the specifications of the recommended equipment.

For the most accurate and convenient performance check, special Tektronix calibration fixtures are used in this procedure. These special calibration fixtures are available from Tektronix, Inc. Order by part number through your local Tektronix Field Office or representative.

1. DC voltmeter (VOM). minimum sensitivity, 20,000 ohms/volt; accuracy, within 3%; range, zero to 12 volts. For example, Triplett Model 630.

2. Time-mark generator. Marker outputs, five seconds to five nanoseconds; marker accuracy, within 0.1%. Tektronix Type 184 Time-Mark Generator recommended.

3. Standard amplitude calibrator. Amplitude accuracy, within 0.25%; signal amplitude, five millivolts to 50 volts; output signal, one-kilohertz square wave and positive DC voltage; must have mixed display feature. Tektronix calibration fixture 067-0502-00 recommended.

4. Square-wave generator. Frequency, one kilohertz and one megahertz; risetime, one nanosecond or less from fast-rise output; output amplitude, about 120 volts unterminated or 12 volts into 50 ohms. Tektronix Type 106 Square-Wave Generator recommended.

5. Fast-rise, high-amplitude pulse generator. Risetime, 0.25 nanosecond or less; repetition rate, 550 to 720 pulses/second; amplitude, variable from 20 millivolts to 10 volts. Tektronix Type 109 Pulse Generator recommended.

6. Charge line. Impedance, 50 ohms; electrical length, 50 nanoseconds; connectors, GR874. Tektronix Type 113 Delay Cable recommended.

7. High-Frequency constant-amplitude sine-wave generator. Frequency, 65 megahertz to above 150 megahertz; reference frequency, three megahertz; output amplitude, variable from 0.5 volt to five volts; amplitude accuracy, within 3% at three megahertz and from 65 megahertz to 150 megahertz. Tektronix calibration fixture 067-0532-00 recommended.

8. Medium-frequency constant-amplitude sine-wave generator. Frequency, 350 kilohertz to 100 megahertz; reference frequency, 50 kilohertz; output amplitude, variable from five millivolts to five volts into 50 ohms or 10 volts unterminated; amplitude accuracy, within 3% at 50 kilohertz and from 350 kilohertz to 100 megahertz. Tektronix Type 191 Constant Amplitude Signal Generator recommended.

9. Low-frequency sine-wave generator. Frequency, 10 hertz to one megahertz; output amplitude, variable from 0.5 volts to 40 volts peak to peak; amplitude accuracy, within 3% from 10 hertz to one megahertz. For example, General Radio 1310-A Oscillator (use a General Radio Type 274QBJ Adaptor to provide BNC output).

10. $10\times$ probe with BNC connector. Tektronix P6047 recommended.

11. Test oscilloscope. Bandwidth, DC to 50 MHz; minimum deflection factor, five millivolts/division; accuracy, within 3%. Tektronix Type 453 or Type 454 Oscilloscope recommended.

12. Current-measuring probe with passive termination. Sensitivity, two milliamperes/millivolt; accuracy, within 3%. Tektronix P6019 Current Probe with 011-0078-00 passive termination recommended.

13. Cable (two). Impedance, 50 ohms; type, RG-58/U; length, 42 inches; connectors, BNC. Tektronix Part No. 012-0057-00.

14. BNC T connector. Tektronix Part No. 103-0030-00.

15. Cable. Impedance, 50 ohms; type, RG-58/U; length, 18 inches; connectors, BNC. Tektronix Part No. 012-0076-00.

16. Cable (two). Impedance, 50 ohms; type RG-213/U; electrical length, five nanoseconds; connectors, GR874. Tektronix Part No. 017-0502-00.

17. In-line termination. Impedance, 50 ohms; wattage rating, two watts; accuracy, $\pm 3\%$; connectors, GR874 input with BNC male output. Tektronix Part No. 017-0083-00.

18. Elbow. Impedance, 50 ohms; Connectors, GR874. Tektronix Part No. 017-0070-00.

19. Short-circuit termination connector, GR874. Tektronix Part No. 017-0087-00.

20. Input RC normalizer. Time constant, 1 megohm \times 20 pF; attenuation, $2\times$; connectors, BNC. Tektronix calibration fixture 067-0538-00.

Performance Check—Type 454/R454

21. 5× attenuator. Impedance, 50 ohms; accuracy, ±3%; connectors, GR874. Tektronix Part No. 017-0079-00.

22. 10× attenuator. Impedance, 50 ohms; accuracy, ±3%; connectors, GR874. Tektronix Part No. 017-0078-00.

23. Dual-input coupler. Matched signal transfer to each input. Tektronix calibration fixture 067-0525-00.

24. Adapter. Adapts GR874 connector to BNC female connector. Tektronix Part No. 017-0064-00.

25. Termination. Impedance, 50 ohms; accuracy, ±3%; connectors, BNC. Tektronix Part No. 011-0049-00.

26. 5× attenuator. Impedance, 50 ohms; accuracy, ±3%; connectors, BNC. Tektronix Part No. 011-0060-00.

27. Adapter. Connectors, BNC female and two alligator clips. Tektronix Part No. 013-0076-00.

28. Screwdriver. Three-inch shaft. Tektronix Part No. 003-0192-00.

PERFORMANCE CHECK PROCEDURE

General

In the following procedure, control settings or test equipment connections should not be changed except as noted. If only a partial check is desired, refer to the preceding step(s) for setup information. Type 454 front-panel control titles referred to in this procedure are capitalized (e.g., VOLTS/DIV).

The following procedure uses the equipment listed under Recommended Equipment. If equipment is substituted, control settings or setup may need to be altered to meet the requirements of the equipment used.

Preliminary Procedure

1. Connect the Type 454 to a power source which meets the voltage and frequency requirements of this instrument.

2. Set the Type 454 controls as follows:

CRT controls

| | |
|----------------|------------------|
| INTENSITY | Counterclockwise |
| FOCUS | Midrange |
| SCALE ILLUM | As desired |
| BW-BEAM FINDER | FULL |

Vertical controls (both channels if applicable)

| | |
|----------------|-----------|
| VOLTS/DIV | 20 mV |
| VARIABLE | CAL |
| POSITION | Midrange |
| Input Coupling | DC |
| MODE | CH 1 |
| TRIGGER | NORM |
| INVERT | Pushed in |

Triggering controls (both A and B if applicable)

| | |
|----------|-----|
| LEVEL | 0 |
| SLOPE | + |
| COUPLING | AC |
| SOURCE | INT |

Sweep controls

| | |
|-----------------------|------------------------------|
| DELAY-TIME MULTIPLIER | 0.10 |
| A TIME/DIV | 1 ms |
| B TIME/DIV | 1 ms |
| A VARIABLE | CAL |
| A SWEEP MODE | AUTO TRIG |
| B SWEEP MODE | TRIGGERABLE AFTER DELAY TIME |
| HORIZ DISPLAY | A |
| MAG | OFF |
| A SWEEP LENGTH | FULL |
| POSITION | Midrange |
| POWER | Off |

Side-panel controls

| | |
|---------------------|-----|
| B TIME/DIV VARIABLE | CAL |
|---------------------|-----|

3. Set the POWER switch to ON. Allow at least 20 minutes warm up before proceeding.

1. Check Voltage at PROBE POWER connectors

REQUIREMENT—+12 volts, —12 volts and ground at the correct terminals of the CH 1 and CH 2 PROBE POWER connectors.

a. Connect the DC voltmeter between the +12-volt terminal of the CH 1 PROBE POWER connector (see Fig. 5-1) and the ground terminal.

b. CHECK—Meter reading +12 volts.

c. Connect the DC voltmeter between the —12-volt terminal of the CH 1 PROBE POWER connector (see Fig. 5-1) and the ground terminal.

d. CHECK—Meter reading —12 volts.

e. Connect the DC voltmeter between the ground terminal of the CH 1 PROBE POWER connector (see Fig. 5-1) and chassis ground.

f. CHECK—Meter reading zero volts.

g. Connect the DC voltmeter between the +12-volt terminal of the CH 2 PROBE POWER connector (see Fig. 5-1) and the ground terminal.

h. CHECK—Meter reading +12 volts.

i. Connect the DC voltmeter between the —12-volt terminal of the CH 2 PROBE POWER connector (see Fig. 5-1) and the ground terminal.

j. CHECK—Meter reading —12 volts.

k. Connect the DC voltmeter between the ground terminal of the CH 2 PROBE POWER connector (see Fig. 5-1) and chassis ground.

l. CHECK—Meter reading zero volts.

m. Disconnect the DC voltmeter.

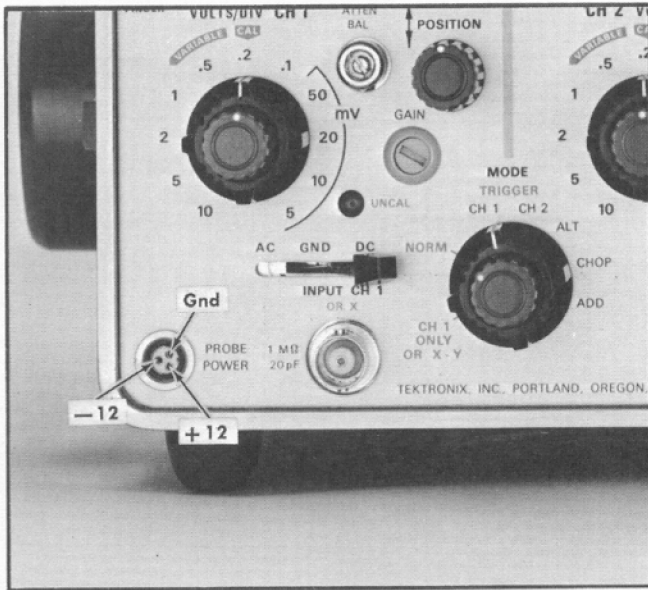

Fig. 5-1. Location of terminals in the CH 1 and 2 PROBE POWER connectors.

2. Check Trace Alignment

REQUIREMENT—Trace parallel to horizontal graticule lines.

- Advance the INTENSITY control until the trace is visible.
- Turn the CH 1 POSITION control to move the trace to the center horizontal line.
- Adjust the FOCUS control for as sharp a display as possible.
- CHECK—The trace should be parallel with the center line.
- If necessary, adjust the TRACE ROTATION adjustment, (on side panel) so the trace is parallel to the horizontal graticule lines.

3. Check Astigmatism

REQUIREMENT—Sharp, well-defined display.

- Connect the time-mark generator (Type 184) to the INPUT CH 1 connector with the 42-inch BNC cable.
- Set the time-mark generator for output markers of 1 and 0.1 millisecond.
- Set the CH 1 VOLTS/DIV switch so the large markers extend beyond the bottom and top of the graticule area.
- Set the A LEVEL control for a stable display.
- CHECK—Markers should be well defined with optimum setting of FOCUS control.
- If necessary, adjust the FOCUS control and ASTIG adjustment (on side panel) for best definition of markers.

4. Check Y Axis Alignment and Geometry

REQUIREMENT—Y axis alignment, markers parallel to center vertical line within 0.1 division; geometry, bowing or tilt of markers at left and right extremes of display within 0.1 division or less.

- Set the horizontal POSITION control to move a large marker to the center vertical line.
- CHECK—Marker parallel to the center vertical line within 0.1 division (see Fig. 5-2).
- Set the horizontal POSITION and A VARIABLE controls so a large marker coincides with each vertical graticule line.
- CHECK—Bowling and tilt of markers over entire display area within 0.1 division or less (see Fig. 5-2).
- Disconnect all test equipment.

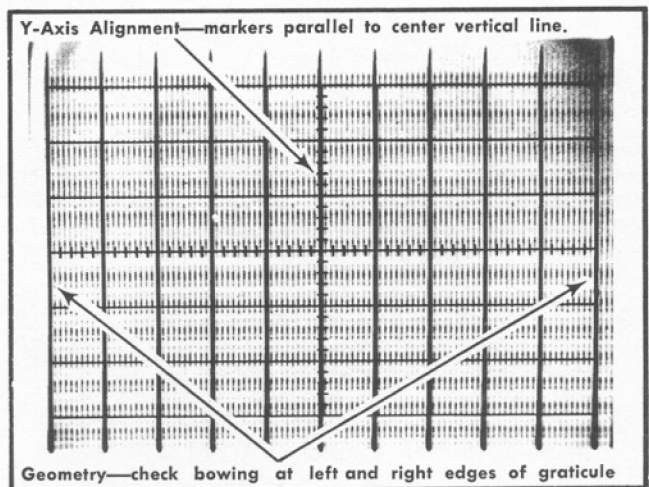

Fig. 5-2. Typical CRT display showing good geometry and y axis alignment.

5. Check Channel 1 and 2 Step Attenuator Balance

REQUIREMENT—0.1 division, or less, trace shift as VOLTS/DIV switch is changed to next deflection factor between 20 mV and 5 mV.

- Position the trace to the center horizontal line with the CH 1 POSITION control.
- Change the following control settings:

| | |
|-----------------------------|-------|
| CH 1 VOLTS/DIV | 20 mV |
| Input Coupling (CH 1 and 2) | GND |
- CHECK—Change the CH 1 VOLTS/DIV switch from 20 mV to 5 mV. Trace should not move more than 0.1 division vertically at each step.
- If there is trace shift, adjust the CH 1 STEP ATTEN BAL adjustment (on front panel) for no trace shift as the CH 1 VOLTS/DIV switch is changed from 20 mV to 5 mV.

Performance Check—Type 454/R454

NOTE

Use the BW-BEAM FINDER switch to locate the trace if it is deflected off screen when switching to 10 or 5 mV.

- e. Set the MODE switch to CH 2.
- f. Position the trace to the center horizontal line with the CH 2 POSITION control.
- g. CHECK—Change the CH 2 VOLTS/DIV switch from 20 mV to 5 mV. Trace should not move more than 0.1 division vertically at each step.
- h. If there is trace shift, adjust the CH 2 STEP ATTEN BAL adjustment (on front panel) for no trace shift as the CH 2 VOLTS/DIV switch is changed from 20 mV to 5 mV.

6. Check Channel 1 and 2 Position Centering

REQUIREMENT—Trace positioned beyond graticule limits at both extremes of POSITION control rotation.

- a. Set the CH 1 and CH 2 VARIABLE controls for minimum gain (clockwise just past CAL detent).
- b. Set the CH 1 and CH 2 VOLTS/DIV switches to .1.
- c. CHECK—Turn the CH 2 POSITION control to each extreme of rotation; trace should be positioned beyond the graticule limits at each extreme of rotation.
- d. Set the MODE switch to CH 1.
- e. CHECK—Turn the CH 1 POSITION control to each extreme of rotation; trace should be positioned beyond the graticule limits at each extreme of rotation.

7. Check Channel 1 and 2 Gain

REQUIREMENT—Correct vertical deflection in the 20 mV position of the CH 1 and CH 2 VOLTS/DIV switches.

- a. Change the following control settings:

| | |
|-----------------------------|-------|
| VOLTS/DIV (CH 1 and 2) | 20 mV |
| VARIABLE (CH 1 and 2) | CAL |
| Input Coupling (CH 1 and 2) | DC |
| MODE | CH 1 |
| A and B TIME/DIV | .5 ms |
- b. Connect the standard amplitude calibrator (067-0502-00) output connector to the INPUT CH 1 and INPUT CH 2 connectors through a BNC T connector and two BNC cables.
- c. Set the standard amplitude calibrator for a 0.1-volt square-wave output.
- d. CHECK—CRT display for five divisions of deflection (see Fig. 5-3).
- e. If necessary, adjust the CH 1 GAIN adjustment (on front panel) for exactly five divisions of deflection.
- f. Set the MODE switch to ADD.
- g. Pull the INVERT switch.
- h. Center the display with the CH 2 POSITION control.

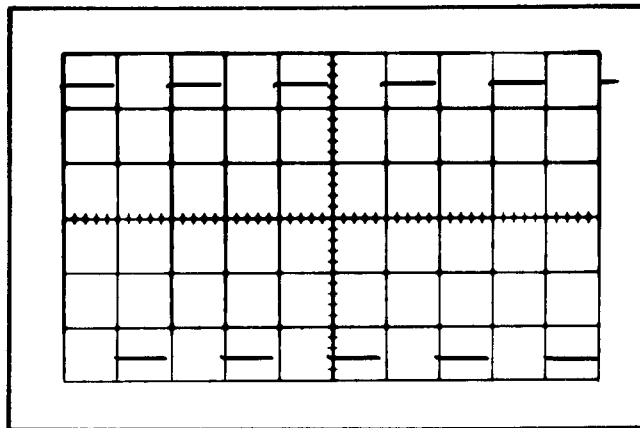

Fig. 5-3. Typical CRT display showing correct vertical gain.

- i. CHECK—CRT display for straight line.
- j. If necessary, adjust the CH 2 GAIN adjustment (on front panel) for straight line.

8. Check Added Mode Operation

REQUIREMENT—Correct signal addition within 3%.

- a. Push the INVERT switch in.
- b. Set the standard amplitude calibrator for a 50 millivolt square-wave output.
- c. CHECK—CRT display five divisions, ± 0.15 divisions, in amplitude (within 3%).

9. Check Channel 1 and 2 Deflection Accuracy

REQUIREMENT—Vertical deflection factor within 3% of CH 1 and CH 2 VOLTS/DIV switch indication.

TABLE 5-1
Vertical Deflection Accuracy

| VOLTS/DIV Switch Setting | Standard Amplitude Calibrator Output | Vertical Deflection In Divisions | Maximum Error For $\pm 3\%$ Accuracy (divisions) |
|--------------------------|--------------------------------------|----------------------------------|--|
| 5 mV | 20 millivolts | 4 | ± 0.12 |
| 10 mV | 50 millivolts | 5 | ± 0.15 |
| 20 mV | 0.1 volt | 5 | Previously set in step 7 |
| 50 mV | 0.2 volt | 4 | ± 0.12 |
| .1 | 0.5 volt | 5 | ± 0.15 |
| .2 | 1 volt | 5 | ± 0.15 |
| .5 | 2 volts | 4 | ± 0.12 |
| 1 | 5 volts | 5 | ± 0.15 |
| 2 | 10 volts | 5 | ± 0.15 |
| 5 | 20 volts | 4 | ± 0.12 |
| 10 | 50 volts | 5 | ± 0.15 |

- a. Set the MODE switch to CH 1.
- b. Set the CH 2 Input Coupling switch to GND.
- c. CHECK—Using the CH 1 VOLTS/DIV switch and standard amplitude calibrator settings given in Table 5-1, check vertical deflection factor within 3% in each position of the CH 1 VOLTS/DIV switch.
- d. Set the MODE switch to CH 2.
- e. Set the CH 1 Input Coupling switch to GND and the CH 2 Input Coupling switch to DC.
- f. CHECK—Using the CH 2 VOLTS/DIV switch and standard amplitude calibrator settings given in Table 5-1, check the vertical deflection factor within 3% in each position of the CH 2 VOLTS/DIV switch.

10. Check Channel 1 and 2 Variable Volts/Division Range

REQUIREMENT—Continuously variable deflection factor between the calibrated steps.

- a. Set the standard amplitude calibrator for a 0.1-volt square-wave output.
- b. Change the following control settings:

| | |
|-----------------------------|-------|
| VOLTS/DIV (CH 1 and 2) | 20 mV |
| Input Coupling (CH 1 and 2) | AC |
| MODE | CH 1 |
- c. CHECK—Turn the CH 1 VARIABLE control clockwise just past the CAL detent (minimum gain). Display should be reduced to two divisions or less (indicates adequate range for continuously variable deflection factors between the calibrated steps; see Fig. 5-4); CH 1 UNCAL light must be on when CH 1 VARIABLE control is not in CAL position.
- d. Set the MODE switch to CH 2.
- e. CHECK—Turn the CH 2 VARIABLE control clockwise just past the CAL detent (minimum gain). Display should be reduced to two divisions or less (indicates adequate range for continuously variable deflection factors between calibrated steps; see Fig. 5-4). CH 2 UNCAL light must be on when CH 2 VARIABLE control is not in CAL position.
- f. Disconnect the cable from the INPUT CH 2 connector.

11. Check Channel 1 and 2 Cascaded Deflection Factor

REQUIREMENT—One millivolt/division or less.

- a. Connect the CH 1 OUT connector to the INPUT CH 2 connector with the 18-inch 50-ohm BNC cable.
- b. Change the following control settings:

| | |
|-----------------------------|------|
| VOLTS/DIV (CH 1 and 2) | 5 mV |
| VARIABLE (CH 1 and 2) | CAL |
| Input Coupling (CH 1 and 2) | DC |
- c. Set the standard amplitude calibrator for a five-millivolt square-wave output.
- d. CHECK—CRT display five divisions or greater in amplitude (one millivolt/division, or less, minimum deflection factor).

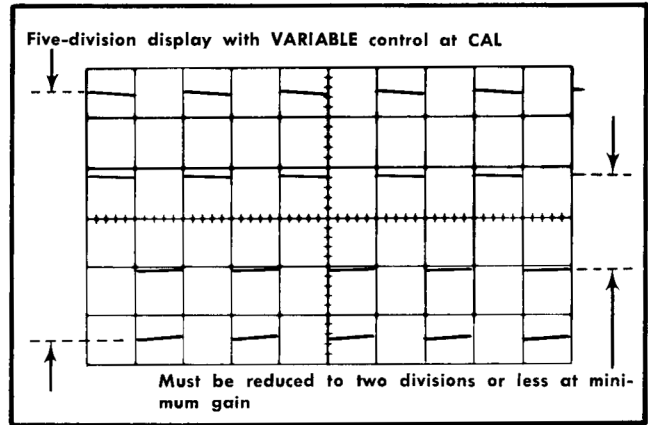

Fig. 5-4. Typical CRT display showing correct Channel 1 and 2 VARIABLE control range (double exposure).

12. Check Channel 1 and 2 Input Coupling Switch Operation

REQUIREMENT—Correct signal coupling in each position of the CH 1 and CH 2 Input Coupling switches.

- a. Set the CH 1 and CH 2 VOLTS/DIV switches to 20 mV.
- b. Disconnect the 18-inch BNC cable and reconnect the standard amplitude calibrator to the INPUT CH 2 connector.
- c. Set the standard amplitude calibrator for a 50-millivolt square-wave output.
- d. Position the display with the CH 2 POSITION control so the bottom of the square wave is at the center horizontal line.
- e. Set the CH 2 Input Coupling switch to GND.
- f. CHECK—CRT display for straight line near the center horizontal line.
- g. Set the CH 2 Input Coupling switch to AC.
- h. CHECK—CRT display centered about center horizontal line.
- i. Set the MODE switch to CH 1.
- j. Position the display with the CH 1 POSITION control so the bottom of the square wave is at the center horizontal line.
- k. Set the CH 1 Input Coupling switch to GND.
- l. CHECK—CRT display for straight line near the center horizontal line.
- m. Set the CH 1 Input Coupling switch to AC.
- n. CHECK—CRT display centered about center horizontal line.

13. Check Low-Frequency Vertical Linearity

REQUIREMENT—0.1 division, or less, compression or expansion of a two-division signal (at center screen) when positioned to the vertical extremes of the graticule area.

- a. Set the CH 1 and CH 2 Input Coupling switches to DC.
- b. Position the display to the center of the graticule with the CH 1 POSITION control.

Performance Check—Type 454/R454

- c. Adjust the CH 1 VARIABLE control for exactly two divisions of deflection.
- d. Position the top of the display to the top horizontal line.
- e. CHECK—Compression or expansion 0.1 division or less (see Fig. 5-5).
- f. Position the bottom of the display to the bottom horizontal line.
- g. CHECK—Compression or expansion 0.1 division or less (see Fig. 5-5).
- h. Set the MODE switch to CH 2.
- i. Position the display to the center of the graticule with the CH 2 POSITION control.

- j. Adjust the CH 2 VARIABLE control for exactly two divisions of deflection.
- k. Position the top of the display to the top horizontal line.
- l. CHECK—Compression or expansion 0.1 division or less (see Fig. 5-5).
- m. Position the bottom of the display to the bottom horizontal line.
- n. CHECK—Compression or expansion 0.1 division or less (see Fig. 5-5).
- o. Disconnect all test equipment.

14. Check Trace Shift Due to Input Grid Current

REQUIREMENT—0.4 division or less at 5 mV/DIV.

- a. Change the following control settings:

| | |
|-----------------------------|------|
| VOLTS/DIV (CH 1 and 2) | 5 mV |
| VARIABLE (CH 1 and 2) | CAL |
| Input Coupling (CH 1 and 2) | GND |
- b. Position the trace to the center horizontal line with the CH 2 POSITION control.
- c. CHECK—Set the CH 2 Input Coupling switch to DC and note the trace shift; 0.4 division or less.
- d. Set the MODE switch to CH 1.
- e. Position the trace to the center horizontal line with the CH 1 POSITION control.
- f. CHECK—Set the CH 1 Input Coupling switch to DC and note the trace shift; 0.4 division or less.

15. Check Alternate Operation

REQUIREMENT—Trace alternation at all sweep rates.

- a. Set the MODE switch to ALT.
- b. Position the traces about two divisions apart.
- c. Turn the A TIME/DIV switch throughout its range.
- d. CHECK—Trace alternation between Channel 1 and 2 at all sweep rates. At faster sweep rates, alternation will not be apparent; display will appear as two traces on the screen.

16. Check Channel 1 Volts/Division Switch Compensation

REQUIREMENT—3% or less overshoot, rounding or tilt in all positions of the CH 1 VOLTS/DIV switch.

- a. Change the following control settings:

| | |
|------------------------|-------|
| VOLTS/DIV (CH 1 and 2) | .1 |
| MODE | CH 1 |
| A and B TIME/DIV | .2 ms |

- b. Connect the square-wave generator (Type 106) high-amplitude output connector to the INPUT CH 1 connector

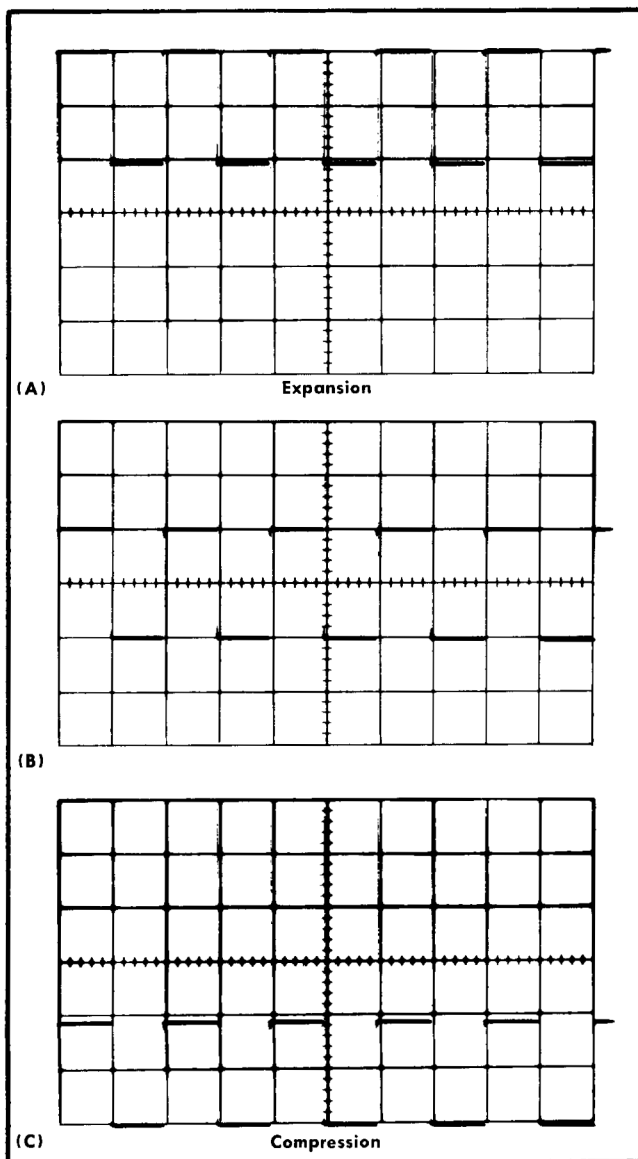

Fig. 5-5. Typical CRT display showing acceptable compression and expansion. (A) Expansion, (B) correct deflection at center of graticule, (C) compression.

through the five-nanosecond GR cable, 50-ohm in-line termination and 20 pF input RC normalizer, in given order.

c. Set the square-wave generator for four divisions of one-kilohertz signal.

d. CHECK—CRT display at each CH 1 VOLTS/DIV switch position for 3% or less overshoot, rolloff or tilt (see Fig. 5-6). Adjust the square-wave generator output amplitude as needed to maintain a four-division display (except in 2, 5 and 10 positions where display will be less than four divisions).

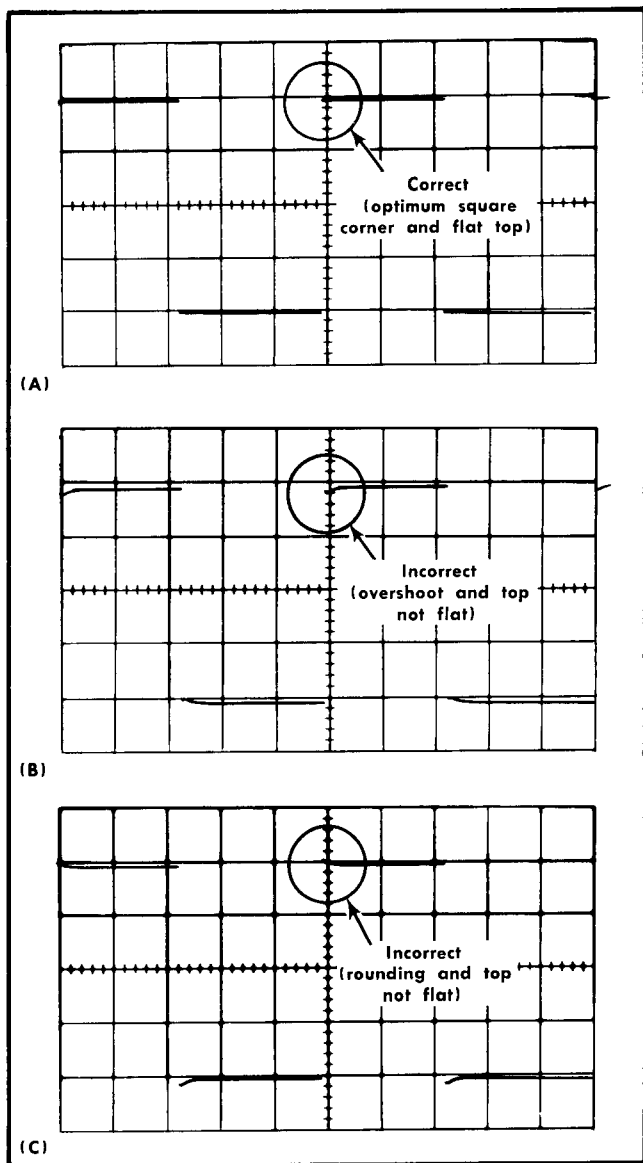

Fig. 5-6. (A) Typical CRT display showing correct compensation, (B) and (C) incorrect compensation.

17. Check Channel 2 Volts/Division Switch Compensation

REQUIREMENT—3% or less overshoot, rounding or tilt in all positions of the CH 2 VOLTS/DIV switch.

a. Set the MODE switch to CH 2.

b. Connect the square-wave generator high-amplitude output connector to the INPUT CH 2 connector through the five-nanosecond GR cable, 50-ohm in-line termination and 20 pF input RC normalizer, in given order.

c. Set the square-wave generator for four divisions of one-kilohertz signal.

d. CHECK—CRT display at each CH 2 VOLTS/DIV switch position for 3% or less overshoot rolloff or tilt (see Fig. 5-6). Adjust the square-wave generator output amplitude as needed to maintain a four-division display (except in 2, 5 and 10 positions where display will be less than four divisions).

18. Check Delay-Line Termination and Compensation

REQUIREMENT—3% or less aberrations in area about 280 nanoseconds after the rising portion of a step function.

a. Change the following control settings:

| | |
|------------------------|-------------|
| VOLTS/DIV (CH 1 and 2) | 10 mV |
| MODE | CH 1 |
| A TIME/DIV | .05 μ s |

b. Connect the square-wave generator fast-rise + output connector to the INPUT CH 1 connector through the five-nanosecond GR cable, 5 \times GR attenuator and 50-ohm in-line termination.

c. Set the square-wave generator for fast-rise operation and four divisions output at one megahertz.

d. CHECK—CRT display for minimum aberrations in the area about 280 nanoseconds (five to six divisions) after the rising portion of the waveform (see Fig. 5-7). Also check for less than 3% tilt of the waveform top.

e. Disconnect all test equipment.

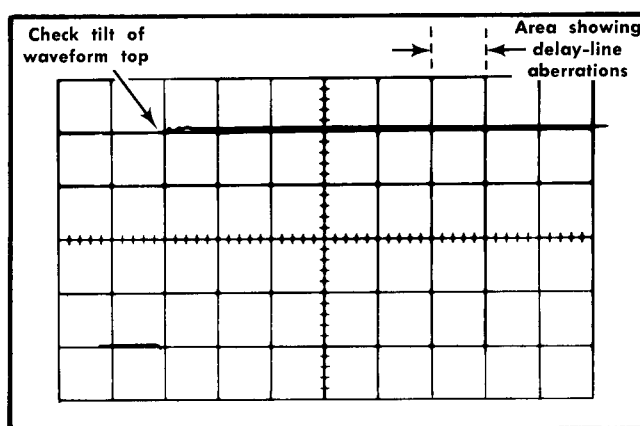

Fig. 5-7. Typical CRT display showing acceptable delay-line termination and compensation.

19. Check Channel 1 High-Frequency Compensation

REQUIREMENT—Flat top and square corner within specified limits.

Performance Check—Type 454/R454

a. Connect the fast-rise, high-amplitude pulse generator (Type 109) 50 Ω output connector to the CH 1 INPUT connector through a five-nanosecond GR cable and the 50-ohm in-line termination.

b. Connect the charge line (Type 113) directly to the charge line 1 connector of the fast-rise, high-amplitude pulse generator with a 50-ohm GR elbow. Support the pulse generator as necessary to make this connection. Connect a GR short-circuit termination to the charge line 2 connector.

c. Change the following control settings:

| | |
|------------------|-------------|
| CH 1 VOLTS/DIV | 10 mV |
| A and B TIME/DIV | .05 μ s |
| MAG | $\times 10$ |

NOTE

The trace alignment and geometry must be correct to perform this step. Check steps 2 and 4 of this procedure to assure correct operation if only steps 19 and 20 are to be performed.

d. Set the fast-rise, high-amplitude pulse generator for a four-division pulse centered vertically and horizontally on the CRT (adjust the A LEVEL control for a stable display).

e. Measure and note the risetime between the 10% and 90% points of the step.

f. Set the A and B TIME/DIV switch to .1 μ s.

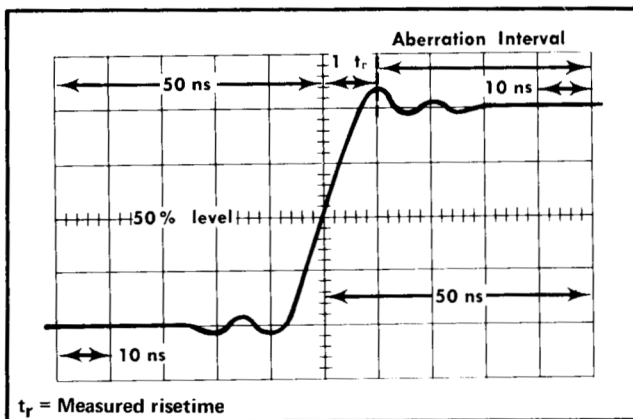

Fig. 5-8. Idealized waveform showing areas used for aberration check.

g. Center the pulse with the horizontal POSITION control. Recheck the amplitude of the pulse and readjust the generator output for four divisions if necessary using the first and last division of the graticule as the reference areas (see Fig. 5-8). If there are any aberrations within the reference areas, use the average levels as the reference. Using this technique, the average level within the first division of the graticule should be positioned to the second horizontal line below the center line and the average level within the last division of the graticule should be positioned to the second horizontal line above the center line. After the pulse is positioned vertically, adjust the horizontal POSITION control so the rising portion of the waveform crosses the center horizontal line exactly at the center vertical line (50% point of step at center vertical line).

h. CHECK—CRT display for a flat top and square corner within $+0.24$ division or -0.24 division, or total peak-to-peak aberrations within 0.24 division (peak aberrations $+6\%$ or -6% ; peak-to-peak aberrations within 6%). Make this measurement within the area one risetime (as measured in part e) to the right of the vertical center line and the last vertical line of the graticule.

i. Change the following control settings:

| | |
|------------------|-------------|
| CH 1 VOLTS/DIV | 5 mV |
| A and B TIME/DIV | .05 μ s |

j. Set the fast-rise, high-amplitude pulse generator for a four-division pulse centered vertically and horizontally on the CRT.

k. Measure and note the risetime between the 10% and 90% points of the step.

l. Set the A and B TIME/DIV switch to .1 μ s.

m. Center the display vertically and horizontally using the technique given in part g.

n. CHECK—CRT display for a flat top and square corner within $+0.28$ division or -0.28 division, or total peak-to-peak aberrations within 0.28 division (peak aberrations $+7\%$ or -7% ; peak-to-peak aberrations within 7%). Make this measurement within the area one risetime (as measured in part k) to the right of the vertical center line and the last vertical line of the graticule.

o. Change the following control settings:

| | |
|------------------|-------------|
| CH 1 VOLTS/DIV | 20 mV |
| A and B TIME/DIV | .05 μ s |

p. Set the fast-rise, high-amplitude pulse generator for a four-division pulse centered vertically and horizontally on the CRT.

q. Measure and note the risetime between the 10% and 90% points of the step.

r. Set the A and B TIME/DIV switch to .1 μ s.

s. Center the display vertically and horizontally using the technique given in part g.

t. CHECK—CRT display for a flat top and square corner within $+0.2$ division or -0.2 division, or total peak-to-peak aberrations within 0.2 division (peak aberrations $+5\%$ or -5% ; peak-to-peak aberrations within 5%). Make this measurement within the area one risetime (as measured in part q) to the right of the vertical center line and the last vertical line of the graticule.

u. Change the following control settings:

| | |
|------------------|-------------|
| CH 1 VOLTS/DIV | 50 mV |
| A and B TIME/DIV | .05 μ s |

v. Set the fast-rise, high-amplitude pulse generator for a four-division pulse centered vertically and horizontally on the CRT.

w. Measure and note the risetime between the 10% and 90% points of the step.

x. Set the A and B TIME/DIV switch to .1 μ s.

y. Center the display vertically and horizontally using the technique given in part g.

z. CHECK—CRT display for a flat top and square corner within $+0.2$ or -0.2 division, or total peak-to-peak aberrations within 0.2 division (peak aberrations $+5\%$ or -5% ; peak-to-peak aberrations within 5%). Make this measurement within the area one risetime (as measured in part w) to the right of the vertical center line and the last vertical line of the graticule.

aa. Change the following control settings:

| | |
|------------------|-------------------|
| CH 1 VOLTS/DIV | .1 |
| A and B TIME/DIV | .05 μs |

ab. Set the fast-rise, high-amplitude pulse generator for a four-division pulse centered vertically and horizontally on the CRT.

ac. Measure and note the risetime between the 10% and 90% points of the step.

ad. Set the A and B TIME/DIV switch to .1 μs .

ae. Center the display vertically and horizontally using the technique given in part g.

af. CHECK—CRT display for a flat top and square corner within $+0.28$ or -0.28 division, or total peak-to-peak aberrations within 0.28 division (peak aberrations $+7\%$ or -7% ; peak-to-peak aberrations within 7%). Make this measurement within the area one risetime (as measured in part ac) to the right of the vertical center line and the last vertical line of the graticule.

20. Check Channel 2 High-Frequency Compensation

REQUIREMENT—Flat top and square corner within specified limits.

a. Disconnect the output of the 50 ohm in-line termination from the INPUT CH 1 connector and connect it to the INPUT CH 2 connector.

b. Set the MODE switch to CH 2.

c. Set the fast-rise, high-amplitude pulse generator for a four-division pulse (CH 2 VOLTS/DIV switch set to 10 mV) centered vertically and horizontally on the CRT.

d. Measure and note the risetime between the 10% and 90% points of the step.

e. Set the A and B TIME/DIV switch to .1 μs .

f. Center the display vertically and horizontally using the technique given in step 19 g.

g. CHECK—CRT display for a flat top and square corner within $+0.24$ division or -0.24 division, or total peak-to-peak aberrations within 0.24 division (peak aberrations $+6\%$ or -6% ; peak-to-peak aberrations within 6%). Make this measurement within the area one risetime (as measured in part d) to the right of the vertical center line and the last vertical line of the graticule.

h. Change the following control settings:

| | |
|------------------|-------------------|
| CH 1 VOLTS/DIV | 5 mV |
| A and B TIME/DIV | .05 μs |

i. Set the fast-rise, high-amplitude pulse generator for a four-division pulse centered vertically and horizontally on the CRT.

j. Measure and note the risetime between the 10% and 90% points of the step.

k. Set the A and B TIME/DIV switch to .1 μs .

l. Center the display vertically and horizontally using the technique given in step 19 g.

m. CHECK—CRT display for a flat top and square corner within $+0.28$ division or -0.28 division, or total peak-to-peak aberrations within 0.28 division (peak aberrations $+7\%$ or -7% ; peak-to-peak aberrations within 7%). Make this measurement within the area one risetime (as measured in part j) to the right of the vertical center line and the last vertical line of the graticule.

n. Change the following control settings:

| | |
|------------------|-------------------|
| CH 1 VOLTS/DIV | 20 mV |
| A and B TIME/DIV | .05 μs |

o. Set the fast-rise, high-amplitude pulse generator for a four-division pulse centered vertically and horizontally on the CRT.

p. Measure and note the risetime between the 10% and 90% points of the step.

q. Set the A and B TIME/DIV switch to .1 μs .

r. Center the display vertically and horizontally using the technique given in step 19 g.

s. CHECK—CRT display for a flat top and square corner within $+0.2$ division or -0.2 division, or total peak-to-peak aberrations within 0.2 division (peak aberrations $+5\%$ or -5% ; peak-to-peak aberrations within 5%). Make this measurement within the area one risetime (as measured in part p) to the right of the vertical center line and the last vertical line of the graticule.

t. Change the following control settings:

| | |
|------------------|-------------------|
| CH 1 VOLTS/DIV | 50 mV |
| A and B TIME/DIV | .05 μs |

u. Set the fast-rise, high-amplitude pulse generator for a four-division pulse centered vertically and horizontally on the CRT.

v. Measure and note the risetime between the 10% and 90% points of the step.

w. Set the A and B TIME/DIV switch to 1 μs .

x. Center the display vertically and horizontally using the technique given in step 19 g.

y. CHECK—CRT display for a flat top and square corner within $+0.2$ or -0.2 division, or total peak-to-peak aberrations within 0.2 division (peak aberrations $+5\%$ or -5% ; peak-to-peak aberrations within 5%). Make this measurement within the area one risetime (as measured in part v) to the right of the vertical center line and the last vertical line of the graticule.

z. Change the following control settings:

Performance Check—Type 454/R454

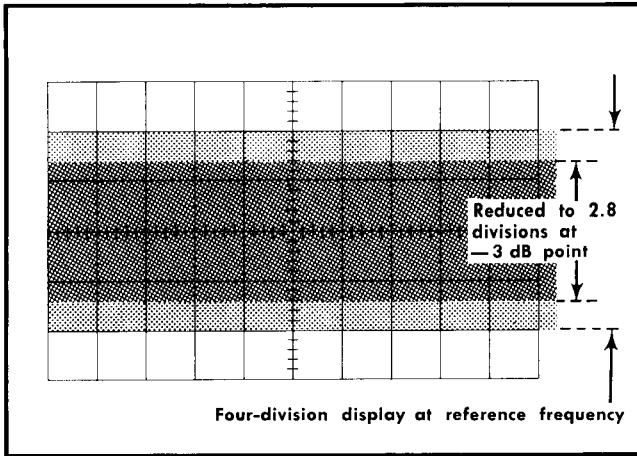

Fig. 5-9. Typical CRT display when checking vertical frequency response.

CH 1 VOLTS/DIV .1
A and B TIME/DIV .05 μ s

aa. Set the fast-rise, high-amplitude pulse generator for a four-division pulse centered vertically and horizontally on the CRT.

ab. Measure and note the risetime between the 10% and 90% points of the step.

ac. Set the A and B TIME/DIV switch to .1 μ s.

ad. Center the display vertically and horizontally using the technique given in step 19g.

ae. CHECK—CRT display for a flat top and square corner within ± 0.28 or -0.28 division, or total peak-to-peak aberrations within 0.28 division (peak aberrations $\pm 7\%$ or -7% ; peak-to-peak aberrations within 7%). Make this measurement within the area one risetime (as measured in part ab) to the right of the vertical center line and the last vertical line of the graticule.

af. Disconnect all test equipment.

21. Check 0.1 Volt, 50 mV, 20 mV and 10 mV Bandwidth of Channels 1 and 2.

REQUIREMENT—0.1 V, 50 mV and 20 mV; not more than -3 dB at 150 megahertz; 10 mV, not more than -3 dB at 100 megahertz.

a. Change the following control settings:

MODE CH 1
A and B TIME/DIV 2 μ s

b. Connect the high-frequency constant-amplitude sine-wave generator (067-0532-00) to the INPUT CH 1 connector through the $10\times$ GR attenuator and 50-ohm in-line termination, in given order.

c. Set the high-frequency generator for a four-division display at its reference frequency (3 MHz).

d. Change the high-frequency generator to the variable frequency position.

e. Without changing the output amplitude, increase the output frequency of the generator until the display is reduced to 2.8 divisions (-3 dB point; see Fig. 5-9).

f. CHECK—Output frequency of generator must be 150 megahertz or higher. Actual frequency, _____ megahertz.

g. Set the CH 1 VOLTS/DIV switch to 50 mV

h. Set the high-frequency generator for a four-division display at its reference frequency (3 MHz).

i. Set the high-frequency generator to the variable frequency position.

j. Without changing the output amplitude, increase the output frequency of the generator until the display is reduced to 2.8 divisions (-3 dB point).

k. CHECK—Output frequency of generator must be 150 megahertz or higher. Actual frequency, _____ megahertz.

l. Set the CH 1 VOLTS/DIV switch to 20 mV.

m. Insert the $5\times$ GR attenuator between the $10\times$ GR attenuator and the 50-ohm in-line termination.

n. Set the high-frequency generator for a four-division display at its reference frequency (3 MHz).

o. Set the high-frequency generator to the variable frequency position.

p. Without changing the output amplitude, increase the output frequency of the generator until the display is reduced to 2.8 divisions (-3 dB point).

q. CHECK—Output frequency of generator must be 150 megahertz or higher. Actual frequency, _____ megahertz.

r. Set the CH 1 VOLTS/DIV switch to 10 mV.

s. Set the high-frequency generator for a four-division display at its reference frequency (3 MHz).

t. Change the high-frequency generator to the variable frequency position.

u. Without changing the output amplitude, increase the output frequency of the generator until the deflection is reduced to 2.8 divisions (-3 dB point).

v. CHECK—Output frequency of generator must be 100 megahertz or higher. Actual frequency, _____ megahertz.

w. Set the MODE switch to CH 2.

x. Disconnect the output of the in-line termination from the INPUT CH 1 connector and connect it to the INPUT CH 2 connector.

y. Remove the $5\times$ GR attenuator.

z. Set the high-frequency generator for a four-division display at its reference frequency (3 MHz).

aa. Set the high-frequency generator to the variable frequency position.

ab. Without changing the output amplitude, increase the output frequency of the generator until the deflection is reduced to 2.8 divisions (-3 dB point).

ac. CHECK—Output frequency of generator must be 150 megahertz or higher. Actual frequency, _____ megahertz.

- ad. Set the CH 2 VOLTS/DIV switch to 50 mV.
- ae. Set the high-frequency generator for a four-division display at its reference frequency (3 MHz).
- af. Set the high-frequency generator to the variable frequency position.
- ag. Without changing the output amplitude, increase the output frequency of the generator until the display is reduced to 2.8 divisions (−3 dB point).
- ah. CHECK—Output frequency of generator must be 150 megahertz or higher. Actual frequency, _____ megahertz.
- ai. Set the CH 2 VOLTS/DIV switch to 20 mV.
- aj. Insert the 5× GR attenuator between the 10× GR attenuator and the 50-ohm in-line termination.
- ak. Set the high-frequency generator for a four-division display at its reference frequency (3 MHz).
- al. Set the high-frequency generator to the variable frequency position.
- am. Without changing the output amplitude, increase the output frequency of the generator until the display is reduced to 2.8 divisions (−3 dB point).
- an. CHECK—Output frequency of generator must be 150 megahertz or higher. Actual frequency, _____ megahertz.
- ao. Set the CH 2 VOLTS/DIV switch to 10 mV.
- ap. Set the high frequency generator for a four-division display at its reference frequency (3 MHz).
- aq. Set the high-frequency generator to the variable frequency position.
- ar. Without changing the output amplitude, increase the output frequency of the generator until the deflection is reduced to 2.8 divisions (−3 dB point).
- as. CHECK—Output frequency of generator must be 100 megahertz or higher. Actual frequency, _____ megahertz.

22. Check Added Mode Bandwidth

REQUIREMENT—Not more than −3 dB at 150 megahertz.

- a. Change the following control settings:

| | |
|------------------------|----------|
| VOLTS/DIV (CH 1 and 2) | 20 mV |
| CH 1 POSITION | Midrange |
| CH 1 Input Coupling | GND |
| MODE | ADD |
- b. Set the high-frequency generator for a four-division display at its reference frequency (3 MHz).
- c. Set the high-frequency generator to its variable frequency position.
- d. Without changing the output amplitude, increase the output frequency of the generator until the deflection is reduced to 2.8 divisions (−3 dB point; see Fig. 5-9).
- e. CHECK—Output frequency of generator must be 150 megahertz or higher. Actual frequency, _____ megahertz.
- f. Change the following control settings:

| | |
|---------------------|----------|
| CH 2 POSITION | Midrange |
| Ch 1 Input Coupling | DC |
| CH 2 Input Coupling | GND |

- g. Disconnect the output of the in-line termination from the INPUT CH 2 connector and connect it to the INPUT CH 1 connector.
- h. Set the high-frequency generator for a four-division display at its reference frequency (3 MHz).
- i. Set the high-frequency generator to its variable frequency position.
- j. Without changing the output amplitude, increase the output frequency of the generator until the deflection is reduced to 2.8 divisions (−3 dB point; see Fig. 5-9).
- k. CHECK—Output frequency of generator must be 150 megahertz or higher. Actual frequency, _____ megahertz.
- l. Disconnect all test equipment.

23. Check 5 mV Bandwidth of Channel 1 and 2

REQUIREMENT—Not more than −3 dB at 60 megahertz.

- a. Change the following control settings:

| | |
|------------------------|-------|
| VOLTS/DIV (CH 1 and 2) | 5 mV |
| MODE | CH 2 |
| CH 2 Input Coupling | DC |
| A and B TIME/DIV | .1 ms |
- b. Connect the medium-frequency constant-amplitude sine-wave generator (Type 191) to the INPUT CH 2 connector through a five-nanosecond GR cable, 10× GR attenuator and the 50-ohm in-line termination.
- c. Set the medium-frequency generator for a four-division display at its reference frequency (50 kHz).
- d. Set the medium-frequency generator to its variable frequency position.
- e. Without changing the output amplitude, increase the output frequency of the generator until the deflection is reduced to 2.8 divisions (−3 dB point; see Fig. 5-9).
- f. CHECK—Output frequency of generator must be 60 megahertz or higher. Actual frequency, _____ megahertz.
- g. Set the MODE switch to CH 1.
- h. Disconnect the output of the in-line termination from the INPUT CH 2 connector and connect it to the INPUT CH 1 connector.
- i. Set the medium-frequency generator for a four-division display at its reference frequency (50 kHz).
- j. Set the medium-frequency generator to its variable frequency position.
- k. Without changing the output amplitude, increase the output frequency of the generator until the deflection is reduced to 2.8 divisions (−3 dB point; see Fig. 5-9).
- l. CHECK—Output frequency of generator must be 60 megahertz or higher. Actual frequency, _____ megahertz.

Performance Check—Type 454/R454

24. Check Channel 1 and 2 Cascaded Bandwidth

REQUIREMENT—Not more than -3 dB at 33 megahertz.

- Connect the CH 1 OUT connector to the INPUT CH 2 connector with an 18-inch, 50-ohm BNC cable.
- Set the MODE switch to CH 2.
- Set the medium-frequency generator for a four-division display at its reference frequency (50 kHz).
- Set the medium-frequency generator to the variable frequency position.
- Without changing the output amplitude, increase the output frequency of the generator until the deflection is reduced to 2.8 divisions (-3 dB point; see Fig. 5-9).
- CHECK—Output frequency of generator must be 33 megahertz or higher. Actual frequency, _____ megahertz.
- Disconnect the cable from between the CH 1 OUT and INPUT CH 2 connectors.

25. Check Bandwidth Limiter Operation

REQUIREMENT—Not more than -3 dB at four megahertz and not less than -3 dB at six megahertz.

- Change the following controls:

| | |
|------------------------|------------|
| VOLTS/DIV (CH 1 and 2) | 20 mV |
| MODE | CH 1 |
| BW-BEAM FINDER | 5 MHz (up) |
- Set the medium-frequency generator for a four-division display at its reference frequency (50 kHz).
- Set the medium-frequency generator to its variable frequency position.
- Without changing the output amplitude, increase the output frequency of the generator until the deflection is reduced to 2.8 divisions (-3 dB point; see Fig. 5-9).
- CHECK—Output frequency of generator must be four megahertz or higher and six megahertz or less.
- Disconnect all test equipment.

26. Check Low-Frequency, AC-Coupled Bandwidth

REQUIREMENT—Not more than -3 dB at 10 hertz.

- Connect the low-frequency constant-amplitude generator to the INPUT CH 1 connector through the 42-inch 50-ohm BNC cable and the 50-ohm BNC termination.
- Change the following control settings:

| | |
|-----------------------------|------|
| BW-BEAM FINDER | FULL |
| Input Coupling (CH 1 and 2) | AC |
| A and B TIME/DIV | .1 s |
- Set the low-frequency generator for a four-division display at one kilohertz.

d. Without changing the output amplitude, reduce the output frequency of the generator until the deflection is reduced to 2.8 divisions (-3 dB point; see Fig. 5-9).

- CHECK—Output frequency of generator must be 10 hertz or less.
- Set the MODE switch to CH 2.
- Disconnect the 50-ohm termination from the INPUT CH 1 connector and connect it to the INPUT CH 2 connector.
- Set the low-frequency generator for a four-division display at one kilohertz.
- Without changing the output amplitude, reduce the output frequency of the generator until the deflection is reduced to 2.8 divisions (-3 dB point; see Fig. 5-9).
- CHECK—Output frequency of generator must be 10 hertz or less.
- Disconnect all test equipment.

27. Check Common-Mode Rejection Ratio

REQUIREMENT—10:1 or greater at 50 megahertz.

- Change the following control settings:

| | |
|-----------------------------|-------|
| VOLTS/DIV (CH 1 and 2) | 50 mV |
| Input Coupling (CH 1 and 2) | DC |
| A and B TIME/DIV | .1 ms |
- Connect the medium-frequency constant-amplitude generator to the INPUT CH 1 and INPUT CH 2 connectors through the five-nanosecond GR cable, 50-ohm in-line termination and the dual-input coupler.
- Set the medium-frequency generator for a 3.2-division display at 50 megahertz.
- Change the following control settings:

| | |
|------------------------|------------|
| VOLTS/DIV (CH 1 and 2) | 20 mV |
| MODE | ADD |
| INVERT | Pulled out |
- CHECK—CRT display for 0.8 division deflection, or less (common-mode rejection ratio 10:1 or better; see Fig. 5-10).

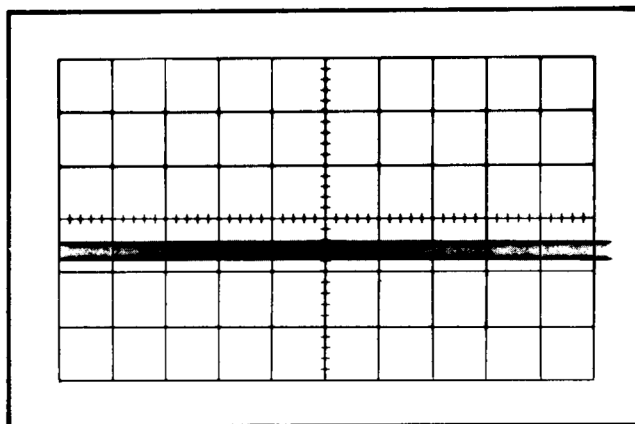

Fig. 5-10. Typical CRT display when checking common-mode rejection ratio.

NOTE

This check applies only when the Channel 1 and 2 gain is correct as given in step 7. If the common-mode rejection ratio is lower than 10:1, check and readjust the gain. Then recheck this step.

- f. Disconnect the dual-input coupler.

28. Check Attenuator Isolation Ratio

REQUIREMENT—10,000:1 or greater at 50 megahertz.

- a. Change the following control settings:

| | |
|---------------------|-----------|
| CH 1 VOLTS/DIV | 1 |
| CH 2 VOLTS/DIV | 5 mV |
| CH 2 Input Coupling | GND |
| MODE | CH 1 |
| INVERT | Pushed in |

b. Connect the medium-frequency constant-amplitude generator to the INPUT CH 1 connector through the five-nano-second GR cable and 50-ohm in-line termination.

c. Set the medium-frequency generator for a five-division display at 50 megahertz (use the variable control of the medium frequency generator, if necessary, to obtain a five-division display).

- d. Set the MODE switch to CH 2.

e. CHECK—CRT display for 0.1-division deflection, or less (attenuator isolation ratio 10,000:1 or better; see Fig. 5-11).

- f. Change the following control settings:

| | |
|---------------------|------|
| CH 1 VOLTS/DIV | 5 mV |
| CH 2 VOLTS/DIV | 1 |
| CH 1 Input Coupling | GND |
| CH 2 Input Coupling | DC |

g. Disconnect the 50-ohm in-line termination from the INPUT CH 1 connector and reconnect it to the INPUT CH 2 connector.

h. Set the medium-frequency generator for a five-division display at 50 megahertz (use the variable control of the generator, if necessary, to obtain a five-division display).

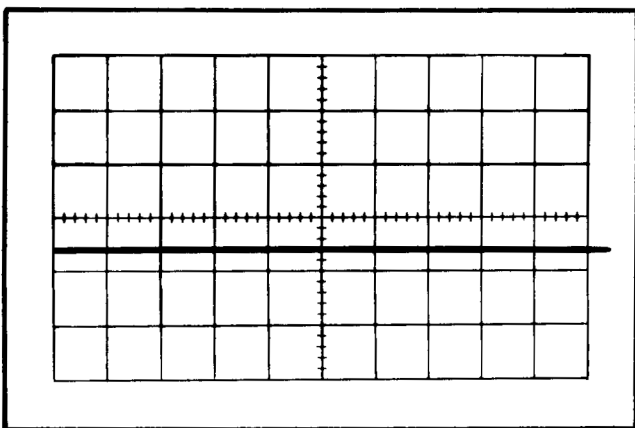

Fig. 5-11. Typical CRT display when checking attenuator isolation ratio and amplifier crosstalk ratio.

- i. Set the MODE switch to CH 1.

j. CHECK—CRT display for 0.1-division deflection or less (attenuator isolation ratio 10,000:1 or better; see Fig. 5-11).

29. Check Amplifier Crosstalk Ratio

REQUIREMENT—100:1 or greater, DC to 50 megahertz.

- a. Change the following control settings:

| | |
|---------------------|------|
| CH 2 VOLTS/DIV | .2 |
| CH 1 Input Coupling | DC |
| MODE | CH 2 |

b. Set the medium-frequency constant-amplitude generator for a two-division display at 50 megahertz.

- c. Set the MODE switch to CH 1.

d. Set the CH 1 and CH 2 VOLTS/DIV switches to 20 mV.

e. CHECK—CRT display for 0.2-division deflection or less (amplifier crosstalk ratio 100:1 or better).

f. Disconnect the 50-ohm in-line termination from the INPUT CH 2 connector and reconnect it to the INPUT CH 1 connector.

- g. Set the CH 1 VOLTS/DIV switch to .2.

h. Set the medium-frequency generator for a two-division display at 50 megahertz.

- i. Change the following control settings:

| | |
|----------------|-------|
| CH 1 VOLTS/DIV | 20 mV |
| MODE | CH 2 |

j. CHECK—CRT display for 0.2-division deflection or less (amplifier crosstalk ratio 100:1 or better).

- k. Disconnect all test equipment.

30. Check CH 1 OUT DC Level

REQUIREMENT—Zero volts, ± 15 millivolts.

- a. Change the following control settings:

| | |
|--------------------------------|-------|
| CH 1 VOLTS/DIV | 20 mV |
| CH 2 VOLTS/DIV | 10 mV |
| INPUT COUPLING (CH 1 and 2) | GND |
| MODE | CH 1 |

b. Connect the CH 1 OUT connector to the INPUT CH 2 connector with an 18-inch 50-ohm BNC cable.

c. Move the trace to the center horizontal line with the CH 1 POSITION control.

- d. Set the MODE switch to CH 2.

e. Move the trace to the center horizontal line with the CH 2 POSITION control.

- f. Set the CH 2 Input Coupling switch to DC.

g. CHECK—CRT display for trace within ± 1.5 divisions of the center horizontal line (zero volts, ± 15 millivolts).

31. Check A and B Trigger Level Centering

REQUIREMENT—Stable display in accordance with following procedure.

a. Change the following control settings:

| | |
|--------------------------------|------------|
| VOLTS/DIV (CH 1 and 2) | 50 mV |
| INPUT COUPLING (CH 1 and 2) | DC |
| MODE | CH 1 |
| LEVEL (A and B) | 0 |
| A and B TIME/DIV | 20 μ s |

b. Connect the medium-frequency constant-amplitude generator to the A EXT TRIG INPUT connector through the five-nanosecond GR cable, GR to BNC adapter and BNC T connector. Connect the output of the BNC T connector to the INPUT CH 1 connector through an 18-inch 50-ohm BNC cable and a 50-ohm BNC termination.

c. Set the medium-frequency generator for a 0.3-division display at 50 kilohertz.

d. Slowly rotate the A LEVEL control until a stable display is presented (A SWEEP TRIG'D light on).

e. CHECK—A LEVEL control must be near 0. This check indicates that the A Trigger Level Center adjustment is set correctly.

f. Change the following control settings:

| | |
|--------------------|-----------|
| TRIGGER | CH 1 ONLY |
| A LEVEL | 0 |
| COUPLING (A and B) | DC |

g. Slowly rotate the CH 1 POSITION control until a stable display is presented (A SWEEP TRIG'D light on).

h. CHECK—CRT display must be within one division of the center horizontal line (see Fig. 5-12). CH 1 light in both A and B Triggering must be on. This check indicates that the Trigger Preamp DC Level adjustment is set correctly.

i. Set the TRIGGER switch to NORM.

j. Slowly rotate the CH 1 POSITION control until a stable display is presented (A SWEEP TRIG'D light on).

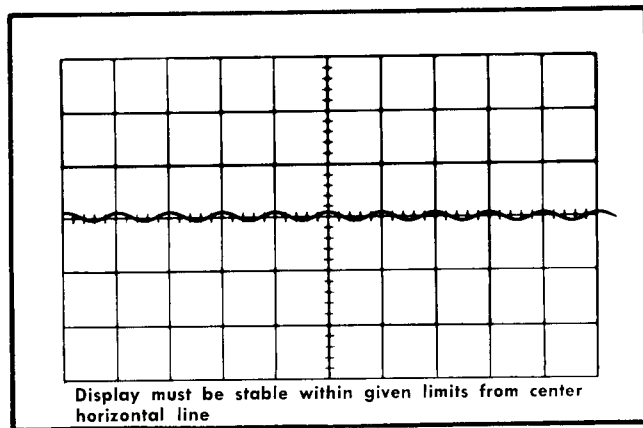

Fig. 5-12. Typical CRT display when checking trigger level centering.

k. CHECK—CRT display must be within two divisions of the center horizontal line (see Fig. 5-12). This check indicates that the Normal Trigger DC Level adjustment is set correctly.

l. Set the HORIZ DISPLAY switch to B (DELAYED SWEEP).

m. Slowly rotate the CH 1 POSITION control until a stable display is presented.

n. CHECK—CRT display must be within two divisions of the center horizontal line (see Fig. 5-12). This check indicates that the B Trigger Level Center adjustment is set correctly.

32. Check A and B 20 Megahertz Triggering Operation

REQUIREMENT—Internal, stable display in AC, LF REJ and DC positions of A and B COUPLING switches with 0.3-division display; external, stable display in AC, LF REJ and DC positions of A and B COUPLING switches with 75-millivolt signal.

a. Set the medium-frequency constant-amplitude generator for a 0.3-division display at 20 megahertz.

b. Set the A and B TIME/DIV switch to .05 μ s.

c. CHECK—Stable CRT display (see Fig. 5-13A) can be obtained with the B COUPLING switch set to AC, LF REJ and DC (B LEVEL control may be adjusted as necessary to obtain stable display).

d. Set the HORIZ DISPLAY switch to A.

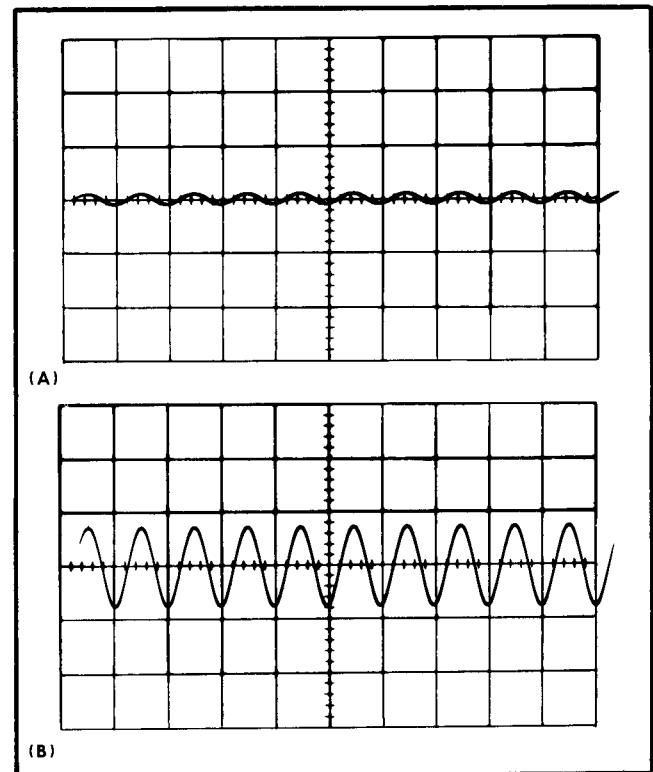

Fig. 5-13. (A) Typical CRT display when checking internal 20 megahertz triggering, (B) typical CRT display when checking external 20 megahertz triggering.

e. CHECK—Stable CRT display (see Fig. 5-13A) can be obtained with the A COUPLING switch set to AC, LF REJ and DC (A LEVEL control may be adjusted as necessary to obtain stable display). The A SWEEP TRIG'D light must be on when the display is stable.

f. Set both SOURCE switches to EXT.

g. Set the medium-frequency generator for a 1.5-division display (75 millivolts) at 20 megahertz.

h. CHECK—Stable CRT display (see Fig. 5-13A) can be obtained with the A COUPLING switch set to AC, LF REJ and DC (A LEVEL control may be adjusted as necessary to obtain stable display).

i. Disconnect the medium-frequency generator from the A EXT TRIG INPUT connector and reconnect it to the B EXT TRIG INPUT connector.

j. Change the following control settings:

| | |
|---------------|---------------------------------------|
| A SOURCE | INT |
| A LEVEL | Triggered display (A TRIG'D light on) |
| HORIZ DISPLAY | B (DELAYED SWEEP) |

k. CHECK—Stable CRT display (see Fig. 5-13B) can be obtained with the B COUPLING switch set to AC, LF REJ and DC (B LEVEL control may be adjusted as necessary to obtain stable display).

l. Disconnect the medium-frequency generator.

33. Check A and B 150 Megahertz Triggering Operation

REQUIREMENT—Internal, stable display in AC, LF REJ and DC positions of A and B COUPLING switches with 1.5-division display; external, stable display in AC, LF REJ and DC positions of A and B COUPLING switches with 375-millivolt signal.

a. Connect the high-frequency constant-amplitude generator (067-0532-00) to the INPUT CH 1 connector through the GR to BNC adapter and BNC T connector. Connect the output of the BNC T connector to the B EXT TRIG INPUT connector through an 18-inch 50-ohm BNC cable, 5× BNC attenuator and 50-ohm BNC termination.

b. Set the CH 1 VOLTS/DIV switch to .5.

c. Set the high-frequency generator for a three-division display (375 millivolts at B EXT TRIG INPUT connector) at its reference frequency (3 MHz).

d. Set the MAG switch to ×10.

e. Without changing the output amplitude, set the high-frequency generator to 150 megahertz.

f. CHECK—Stable CRT display (see Fig. 5-14A) can be obtained with the B COUPLING switch set to AC, LF REJ and DC (B LEVEL control may be adjusted as necessary to obtain stable display).

g. Change the following control settings:

| | |
|---------------|-----|
| A SOURCE | EXT |
| HORIZ DISPLAY | A |

h. Disconnect the high-frequency generator from the B EXT TRIG INPUT connector and reconnect it to the A EXT TRIG INPUT connector.

i. CHECK—Stable CRT display (see Fig. 5-14A) can be obtained with the A COUPLING switch set to AC, LF REJ and DC (A LEVEL and HF STAB controls may be adjusted as necessary to obtain stable display).

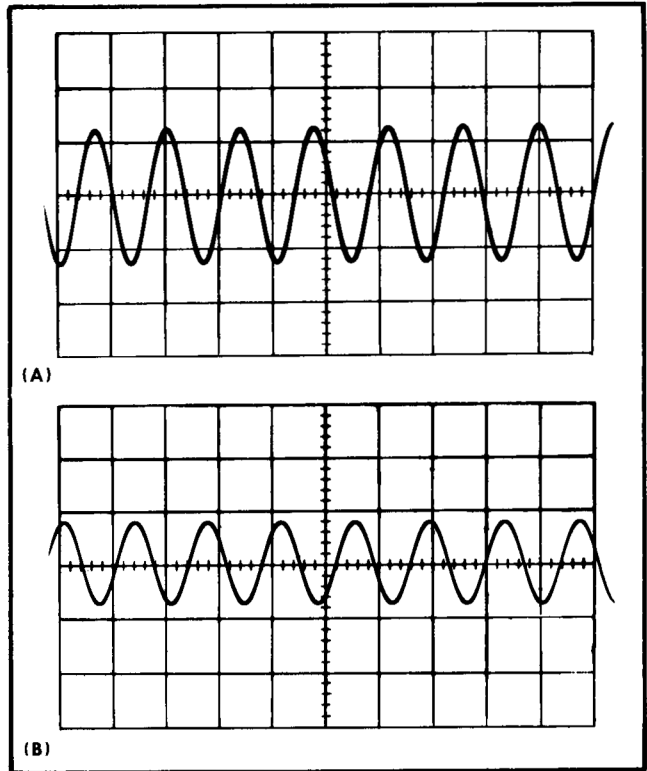

Fig. 5-14. (A) Typical CRT display when checking external 150 megahertz triggering, (B) typical CRT display when checking internal 150 megahertz triggering.

j. Change the following control settings:

| | |
|------------------|-----|
| CH 1 VOLTS/DIV | .1 |
| SOURCE (A and B) | INT |

k. Set the high-frequency generator for a 1.5-division display at 150 megahertz.

l. CHECK—Stable CRT display (see Fig. 5-14B) can be obtained with the A COUPLING switch set to AC, LF REJ and DC (A LEVEL and HF STAB controls may be adjusted as necessary to obtain stable display). Display jitter should not exceed 0.2 division (1.0 nanosecond).

m. Set the HORIZ DISPLAY switch to B (DELAYED SWEEP).

n. CHECK—Stable CRT display (see Fig. 5-14B) can be obtained with the B COUPLING switch set to AC, LF REJ and DC (B LEVEL control may be adjusted as necessary to obtain stable display).

o. Disconnect the high-frequency generator.

34. Check A and B Low-Frequency Triggering Operation

REQUIREMENT—Internal, stable display in AC, HF REJ and DC positions of A and B COUPLING switches with a 0.3-division display; external, stable display in AC, HF REJ and DC positions of A and B COUPLING switches with a 75-millivolt signal.

a. Connect the low-frequency constant-amplitude generator to the A EXT TRIG INPUT connector through a 42-inch 50-ohm BNC cable and the BNC T connector. Connect the output of the BNC T connector to the INPUT CH 1 connector through an 18-inch 50-ohm BNC cable and a 50-ohm BNC termination.

b. Change the following control settings:

| | |
|------------------|--------|
| CH 1 VOLTS/DIV | 50 mV. |
| A and B TIME/DIV | 5 ms |
| MAG | OFF |

c. Set the low-frequency generator for a 0.3-division display at 60 hertz.

d. CHECK—Stable CRT display (see Fig. 5-15A) can be obtained with the B COUPLING switch set to AC, HF REJ and DC (B LEVEL control may be adjusted as necessary to obtain stable display).

e. Set the HORIZ DISPLAY switch to A.

f. CHECK—Stable CRT display (see Fig. 5-15A) can be obtained with the A COUPLING switch set to AC, HF REJ

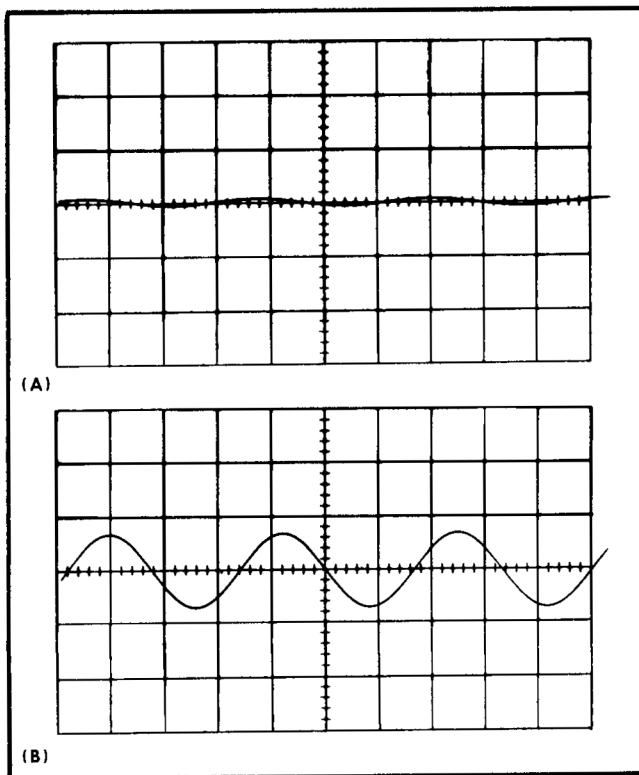

Fig. 5-15. (A) Typical CRT display when checking internal low-frequency triggering at 60 hertz. (B) Typical CRT display when checking external low-frequency triggering at 60 hertz.

and DC (A LEVEL control may be adjusted as necessary to obtain stable display).

g. Set both SOURCE switches to EXT.

h. Set the low-frequency generator for a 1.5-division display (75 millivolts) at 60 hertz.

i. CHECK—Stable CRT display (see Fig. 5-15B) can be obtained with the A COUPLING switch set to AC, HF REJ and DC (A LEVEL control may be adjusted as necessary to obtain stable display).

j. Set the HORIZ DISPLAY switch to B (DELAYED SWEEP).

k. Disconnect the low-frequency generator from the A EXT TRIG INPUT connector and reconnect it to the B EXT TRIG INPUT connector.

l. CHECK—Stable CRT display (see Fig. 5-15B) can be obtained with the B COUPLING switch set to AC, HF REJ and DC (B LEVEL control may be adjusted as necessary to obtain stable display).

35. Check A and B High-Frequency Reject Operation

REQUIREMENT—Stable triggering with 0.3-division display at 50 kilohertz; does not trigger at one megahertz.

a. Change the following control settings:

| | |
|--------------------|------------|
| COUPLING (A and B) | HF REJ |
| SOURCE (A and B) | INT |
| A and B TIME/DIV | 20 μ s |

b. Set the low-frequency constant-amplitude generator for a 0.3-division display at 50 kilohertz.

c. CHECK—Stable CRT display (see Fig. 5-16) can be obtained with the B LEVEL control.

d. Without changing the output amplitude, set the low-frequency generator to one megahertz.

e. Set the MAG switch to $\times 10$.

f. CHECK—Stable CRT display cannot be obtained at any setting of the B LEVEL control.

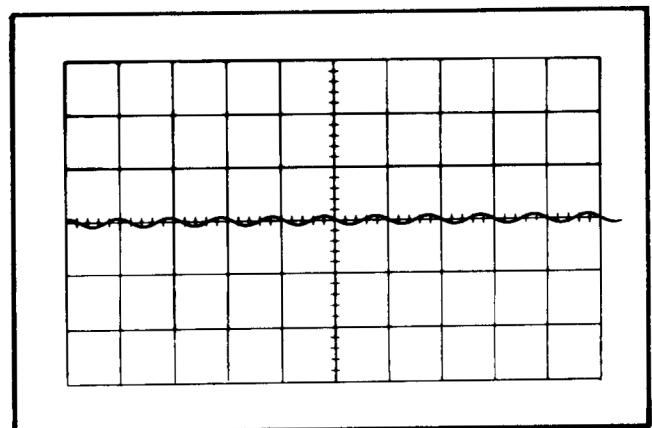

Fig. 5-16. Typical CRT display when checking high-frequency reject operation at 50 kilohertz.

g. Change the following control settings:

| | |
|---------------|-----|
| HORIZ DISPLAY | A |
| MAG | OFF |

h. Set the low-frequency generator for a 0.3-division display at 50 kilohertz.

i. CHECK—Stable CRT display (see Fig. 5-16) can be obtained with the A LEVEL control.

j. Without changing the output amplitude, set the low-frequency generator to one megahertz.

k. Set the MAG switch to $\times 10$.

l. CHECK—Stable CRT display cannot be obtained at any setting of the A LEVEL control.

36. Check A and B Low-Frequency Reject Operation

REQUIREMENT—Stable display with 0.3-division display at 30 kilohertz; does not trigger at 60 hertz.

a. Set the low-frequency generator for a 0.3-division display at 30 kilohertz.

b. Change the following control settings

| | |
|--------------------|--------|
| COUPLING (A and B) | LF REJ |
| A and B TIME/DIV | .1 ms |
| MAG | OFF |

c. CHECK—Stable CRT display (see Fig. 5-17) can be obtained with the A LEVEL control.

d. Without changing the output amplitude, set the low-frequency generator to 60 hertz.

e. Set the A and B TIME/DIV switch to 2 ms.

f. CHECK—Stable CRT display cannot be obtained at any setting of the A LEVEL control.

g. Change the following control settings:

| | |
|------------------|-------------------|
| A and B TIME/DIV | .1 ms |
| HORIZ DISPLAY | B (DELAYED SWEEP) |

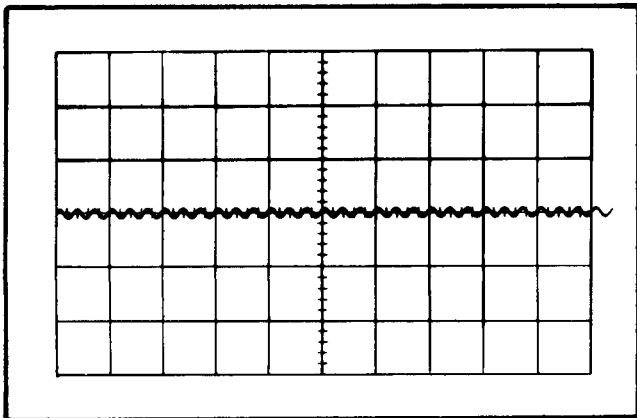

Fig. 5-17. Typical CRT display when checking low-frequency reject operation at 30 kilohertz.

h. Set the low-frequency generator for a 0.3-division display at 30 kilohertz.

i. CHECK—Stable CRT display (see Fig. 5-17) can be obtained with the B LEVEL control.

j. Without changing the output amplitude, set the low-frequency generator to 60 hertz.

k. Set the A and B TIME/DIV switch to 2 ms.

l. CHECK—Stable CRT display cannot be obtained at any setting of the B LEVEL control.

37. Check Single Sweep Operation

REQUIREMENT—Sweep triggers at same A LEVEL control setting as in AUTO TRIG; after each sweep, further displays are locked out until the RESET button is pressed.

a. Change the following control settings:

| | |
|--------------------|------|
| COUPLING (A and B) | AC |
| A and B TIME/DIV | 5 ms |
| HORIZ DISPLAY | A |

b. Set the low-frequency generator for a 0.3-division display at one kilohertz.

c. Adjust the A LEVEL control for a stable display.

d. Disconnect the signal from the INPUT CH 1 connector.

e. Set the A SWEEP MODE switch to SINGLE SWEEP.

f. Push the RESET button.

g. CHECK—RESET light must come on when button is pressed and remain on until signal is reapplied and sweep is completed.

h. Reconnect the signal to the INPUT CH 1 connector.

i. CHECK—A single-sweep display (one sweep only) is presented. RESET light must go off at the end of the sweep and remain off until the RESET button is pressed again.

38. Check A and B Slope Switch Operation

REQUIREMENT—Stable triggering on correct slope of trigger signal.

a. Set the A SWEEP MODE switch to AUTO TRIG.

b. Set the low-frequency generator for a four-division display at one kilohertz.

c. CHECK—CRT display starts on positive slope of the waveform (see Fig. 5-18A).

d. Set the A SLOPE switch to —.

e. CHECK—CRT display starts on negative slope of the waveform (see Fig. 5-18B).

f. Set the HORIZ DISPLAY switch to B (DELAYED SWEEP).

g. CHECK—CRT display starts on positive slope of the waveform (see Fig. 5-18A).

h. Set the B SLOPE switch to —.

i. CHECK—CRT display starts on negative slope of the waveform (see Fig. 5-18B).

Performance Check—Type 454/R454

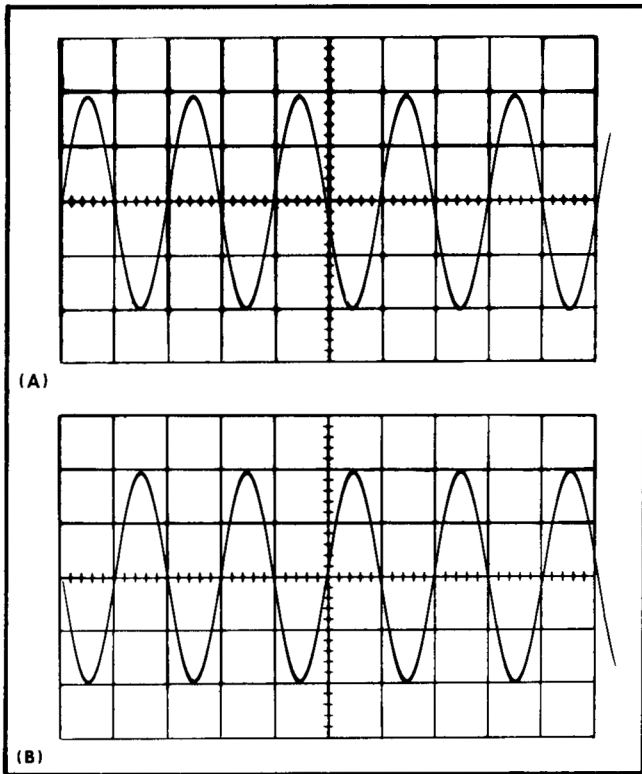

Fig. 5-18. Typical CRT display when checking slope switch operation. (A) SLOPE switch set to +, (B) SLOPE switch set to -.

39. Check A and B Triggering Level Control Range

REQUIREMENT—EXT, at least + and - 2 volts; EXT \div 10, at least + and - 20 volts.

a. Connect the low-frequency generator to the B EXT TRIG INPUT connector through a 42-inch BNC cable and the BNC T connector. Connect the output of the BNC T connector to the INPUT CH 1 connector through an 18-inch BNC cable.

b. Change the following control settings:

| | |
|--------------------|----------|
| CH 1 VOLTS/DIV | 1 |
| LEVEL (A and B) | Midrange |
| COUPLING (A and B) | DC |
| SOURCE (A and B) | EXT |

c. Set the low-frequency generator for a four-division display (four volts peak to peak) at one kilohertz.

d. CHECK—Rotate the B LEVEL control throughout its range and check that display can be triggered at any point along the negative slope of the waveform (indicates B LEVEL control range of at least + and - two volts). Display is not triggered at either extreme of rotation.

e. Set the B SLOPE switch to +.

f. CHECK—Rotate the B LEVEL control throughout its range and check that display can be triggered at any point along the positive slope of the waveform. Display is not triggered at either extreme of rotation.

g. Set the CH 1 VOLTS/DIV switch to 10.

h. Set the A and B SOURCE switches to EXT \div 10.

i. Set the low-frequency generator for a four-division display (40 volts peak to peak) at one kilohertz.

j. CHECK—Rotate the B LEVEL control throughout its range and check that display can be triggered at any point along the positive slope of the waveform (indicates B LEVEL control range of at least + and - 20 volts). Display is not triggered at either extreme of rotation.

k. Set the B SLOPE switch to -.

l. CHECK—Rotate the B LEVEL control throughout its range and check that display can be triggered at any point along the negative slope of the waveform. Display is not triggered at either extreme of rotation.

m. Change the following control settings:

| | |
|---------------|-----------|
| A SWEEP MODE | NORM TRIG |
| HORIZ DISPLAY | A |

n. Disconnect the low-frequency generator from the B EXT TRIG INPUT connector and reconnect it to the A EXT TRIG INPUT connector.

o. CHECK—Rotate the A LEVEL control throughout its range and check that display can be triggered at any point along the negative slope of the waveform (indicates A LEVEL control range of at least + and - 20 volts). Display is not triggered at either extreme of rotation.

p. Set the A SLOPE switch to +.

q. CHECK—Rotate the A LEVEL control throughout its range and check that display can be triggered at any point along the positive slope of the waveform. Display is not triggered at either extreme of rotation.

r. Set the CH 1 VOLTS/DIV switch to 1.

s. Set the A SOURCE switch to EXT.

t. Set the low-frequency generator for a four-division display (four volts peak to peak) at one kilohertz.

u. CHECK—Rotate the A LEVEL control throughout its range and check that display can be triggered at any point along the positive slope of the waveform (indicates A LEVEL control range of at least + and - two volts). Display is not triggered at either extreme of rotation.

v. Set the A SLOPE switch to -.

w. CHECK—Rotate the A LEVEL control throughout its range and check that display can be triggered at any point along the negative slope of the waveform. Display is not triggered at either extreme of rotation.

x. Disconnect all test equipment.

40. Check A and B Line Triggering Operation

REQUIREMENT—Stable display of line-frequency signal, triggered on the correct polarity.

a. Connect the 10 \times probe to the INPUT CH 1 connector.

b. Change the following control settings:

| | |
|------------------|------|
| CH 1 VOLTS/DIV | 10 |
| SOURCE (A and B) | LINE |
| A and B TIME/DIV | 2 ms |

- c. Connect the probe tip to a line-voltage source.
- d. CHECK—Stable CRT display triggered on the correct slope.
- e. Set the A SWEEP MODE switch to AUTO TRIG.
- f. Set the HORIZ DISPLAY switch to B (DELAYED SWEEP).
- g. CHECK—Stable CRT display triggered on the correct slope.
- h. Disconnect all test equipment.

41. Check Auto Recovery Time and Operation

REQUIREMENT—Stable display with 50-millisecond markers (20 hertz); free-running display with 0.1-second markers (10 hertz).

- a. Change the following control settings:

| | |
|------------------------|---------------------------|
| VOLTS/DIV (CH 1 and 2) | .2 |
| SLOPE (A and B) | + |
| COUPLING (A and B) | AC |
| SOURCE (A and B) | INT |
| DELAY-TIME MULTIPLIER | 1.00 |
| A and B TIME/DIV | 50 μ s |
| B SWEEP MODE | B STARTS AFTER DELAY TIME |
| HORIZ DISPLAY | A |

- b. Connect the time-mark generator to the INPUT CH 1 connector through a 42-inch 50-ohm BNC cable and a 50-ohm BNC termination.

- c. Set the time-mark generator for 50-millisecond markers.

CAUTION

To avoid possible burning of the CRT phosphor at slow sweep rates, position the baseline of the marker display below the viewing area.

- d. CHECK—Stable display can be obtained with the A LEVEL control. Marker must be at the start of the sweep.
- e. Set the time-mark generator for 0.1-second markers.
- f. CHECK—Sweep free runs and stable display cannot be obtained. If stable display is obtained, marker must not be at the start of the sweep.

42. Check A Sweep Timing Accuracy

REQUIREMENT—Within 3% over middle eight divisions of the display. Within 5% over any two-division interval within center eight divisions.

- a. CHECK—Using the A TIME/DIV switch and time-mark generator settings given in Table 5-2, check A sweep timing within 0.24 division, over the middle eight divisions of the display (within 3%). Fig. 5-19 shows a typical CRT display when checking sweep timing.

NOTE

Unless otherwise noted, use the middle eight horizontal divisions when checking timing.

TABLE 5-2

A and B Timing Accuracy

| A and B TIME/DIV Switch Setting | Time-Mark Generator Output | CRT Display (markers/division) |
|---------------------------------|----------------------------|--------------------------------|
| .05 μ s | 50 nanosecond | 1 |
| .1 μ s | 0.1 microsecond | 1 |
| .2 μ s | 0.1 microsecond | 2 |
| .5 μ s | 0.5 microsecond | 1 |
| 1 μ s | 1 microsecond | 1 |
| 2 μ s | 1 microsecond | 2 |
| 5 μ s | 5 microsecond | 1 |
| 10 μ s | 10 microsecond | 1 |
| 20 μ s | 10 microsecond | 2 |
| 50 μ s | 50 microsecond | 1 |
| .1 ms | 0.1 millisecond | 1 |
| .2 ms | 0.1 millisecond | 2 |
| .5 ms | 0.5 millisecond | 1 |
| 1 ms | 1 millisecond | 1 |
| 2 ms | 1 millisecond | 2 |
| 5 ms | 5 millisecond | 1 |
| 10 ms | 10 millisecond | 1 |
| 20 ms | 10 millisecond | 2 |
| 50 ms | 50 millisecond | 1 |
| .1 s | 0.1 second | 1 |
| .2 s | 0.1 second | 2 |
| .5 s | 0.5 second | 1 |
| A Sweep Only | | |
| 1 s | 1 second | 1 |
| 2 s | 1 second | 2 |
| 5 s | 5 second | 1 |

- b. Set the time-mark generator for one-millisecond markers.
- c. Set the A TIME/DIV switch to 1 ms.
- d. Position the second marker to the first-division vertical line.
- e. CHECK—Fourth marker within 0.1 division (within 5%) of the third-division vertical line.

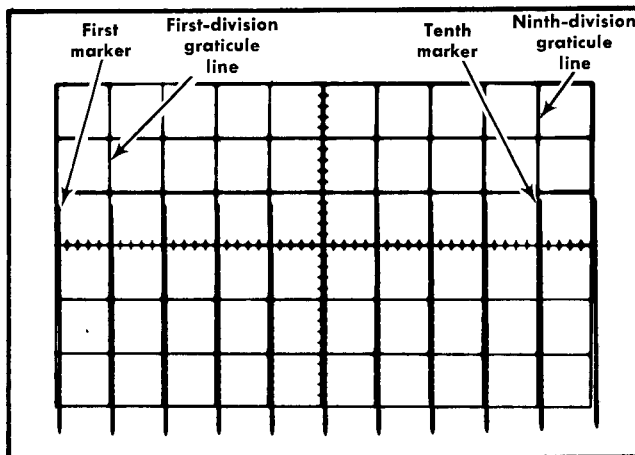

Fig. 5-19. Typical CRT display showing correct A sweep timing.

Performance Check—Type 454/R454

f. Position the third marker to the second-division vertical line.

g. CHECK—Fifth marker within 0.1 division (within 5%) of the fourth-division vertical line.

h. Continue this check for each two-division portion of the sweep within the center eight divisions of the graticule.

43. Check A Magnified Sweep Accuracy

REQUIREMENT—Within 4% over middle eight divisions of the CRT display with the MAG switch set to $\times 10$. Within 5% over any two-division interval within center eight divisions. Magnifier light must be on.

a. Set the MAG switch to $\times 10$.

b. CHECK—Using the A TIME/DIV switch and time-mark generator settings given in Table 5-3, check A magnified sweep timing within 0.32 division over the middle eight divisions of the magnified display (within 4%). Note the portions of the total magnified sweep length to be excluded from the measurement. Magnifier light must be on.

NOTE

Change the CH 1 VOLTS/DIV switch to 50 mV and use the HF STAB control to obtain a stable display of the five-nanosecond markers.

c. Set the time-mark generator for 0.1-millisecond markers.

d. Set the A TIME/DIV switch to 1 ms.

e. Position the first eight-division portion of the total magnified sweep onto the viewing area.

f. CHECK—One marker each division between first- and ninth-division graticule lines; marker at ninth-division vertical line must be within 0.32 division (within 4%) of the line when the marker at the first-division vertical line is positioned exactly.

g. Repeat this check for each eight-division portion of the total magnified sweep length.

h. Set the horizontal POSITION and FINE controls to mid-range.

i. Position a marker to the first-division vertical line.

j. CHECK—Marker within 0.1 division (within 5%) of the third-division vertical line.

k. Position the marker nearest the second-division vertical line to the line.

l. CHECK—Marker within 0.1 division (within 5%) of the fourth-division vertical line.

m. Continue this check for each two-division portion of the displayed sweep within the center eight divisions of the graticule.

44. Check B Sweep Timing Accuracy

REQUIREMENT—Within 3% over middle eight divisions of the display. Within 5% over any two-division interval within center eight divisions.

TABLE 5-3

A and B Magnified Accuracy

| A and B TIME/DIV Switch Setting | Time-Mark Generator Output | CRT Display (Markers/Division) | Portions of total magnified sweep length to exclude from measurement |
|---------------------------------|----------------------------|--------------------------------|--|
| .05 μ s | 5 nanosecond | 1 | First 12 and last six divisions. |
| .1 μ s | 10 nanosecond | 1 | First six and last three divisions. |
| .2 μ s | 10 nanosecond | 2 | First three and last 1.5 divisions. |
| .5 μ s | 50 nanosecond | 1 | |
| 1 μ s | 0.1 microsecond | 1 | |
| 2 μ s | 0.1 microsecond | 2 | |
| 5 μ s | 0.5 microsecond | 1 | |
| 10 μ s | 1 microsecond | 1 | |
| 20 μ s | 1 microsecond | 2 | |
| 50 μ s | 5 microsecond | 1 | |
| .1 ms | 10 microsecond | 1 | |
| .2 ms | 10 microsecond | 2 | |
| .5 ms | 50 microsecond | 1 | |
| 1 ms | 0.1 millisecond | 1 | |
| 2 ms | 0.1 millisecond | 2 | |
| 5 ms | 0.5 millisecond | 1 | |
| 10 ms | 1 millisecond | 1 | |
| 20 ms | 1 millisecond | 2 | |
| 50 ms | 5 millisecond | 1 | |
| .1 s | 10 millisecond | 1 | |
| .2 s | 10 millisecond | 2 | |
| .5 s | 50 millisecond | 1 | |
| 1 s | 0.1 second | 1 | |
| 2 s | 0.1 second | 2 | |
| 5 s | 0.5 second | 1 | |

a. Set the MAG switch to OFF.

b. Set the HORIZ DISPLAY switch to B (DELAYED SWEEP).

c. CHECK—Using the A and B TIME/DIV switch and time-mark generator settings given in Table 5-2, check B sweep timing within 0.25 division over the middle eight divisions of the display (within 3%).

d. Set the time-mark generator for one-millisecond markers.

e. Set the A and B TIME/DIV switch to 1 ms.

f. Position the second marker to the first-division vertical line.

g. CHECK—Fourth marker within 0.1 division (within 5%) of the third-division vertical line.

h. Position the third marker to the second-division vertical line.

i. CHECK—Fifth marker within 0.1 division (within 5%) of the fourth-division vertical line.

j. Continue this check for each two-division portion of the sweep within the center eight divisions of the graticule.

45. Check B Magnified Sweep Accuracy

REQUIREMENT—Within 4% over middle eight divisions of the CRT display with the MAG switch set to $\times 10$. Within 5% over any two-division interval within the center eight divisions.

- a. Set the MAG switch to $\times 10$.
- b. CHECK—Using the A and B TIME/DIV switch and time-mark generator settings given in Table 5-3, check B magnified sweep timing within 0.32 division over the middle eight divisions of the magnified display (within 4%). Note the portions of the total magnified sweep length to be excluded from the measurement.

NOTE

Change the CH 1 VOLTS/DIV switch to 50 mV to display the five-nanosecond markers.

- c. Set the time-mark generator for 0.1-millisecond markers.
- d. Set the A and B TIME/DIV switch to 1 ms.
- e. Set the horizontal POSITION and FINE controls to midrange.
- f. Position a marker to the first-division vertical line.
- g. CHECK—Marker within 0.1 division (within 5%) of the third-division vertical line.
- h. Position the marker nearest the second-division vertical line to the line.
- i. CHECK—Marker within 0.1 division (within 5%) of the fourth-division vertical line.

j. Continue this check for each two-division portion of the displayed sweep within the center eight divisions of the graticule.

46. Check Delay Time Accuracy

REQUIREMENT—DELAY TIME switch (A TIME/DIV) positions of 1 μ s to 50 ms, within 1.5%; .1 s to 5 s, within 2.5%.

- a. Set the MAG switch to OFF.
- b. CHECK—Using the A TIME/DIV switch, B TIME/DIV switch and time-mark generator settings given in Table 5-4, check delayed sweep accuracy within the given tolerance. First set the DELAY-TIME MULTIPLIER dial to 1.00 and rotate the dial until the sweep starts at the top of the second marker (see Fig. 5-20). Note the dial reading and then set the dial to 9.00 and rotate slightly until the sweep starts at the top of the tenth marker. DELAY-TIME MULTIPLIER dial setting must be 8.00 divisions higher, + or – the allowable error given in Table 5-4.

NOTE

Sweep will start at top of third marker at 1.00 and nineteenth marker at 9.00 for sweep rates which are multiples of 2 (e.g., 2 μ s, 20 μ s, .2 ms, etc.). If in doubt as to the correct setting of the DELAY-TIME MULTIPLIER dial, set the HORIZ DISPLAY

TABLE 5-4
Delayed Sweep Accuracy

| A TIME/DIV switch setting | B TIME/DIV switch setting | Time-Mark Generator Output | Allowable Error for Given Accuracy |
|---------------------------|---------------------------|----------------------------|---|
| 1 μ s | .1 μ s | 1 microsecond | ± 12 minor dial divisions ($\pm 1.5\%$) |
| 2 μ s | .1 μ s | 1 microsecond | |
| 5 μ s | .5 μ s | 5 microsecond | |
| 10 μ s | 1 μ s | 10 microsecond | |
| 20 μ s | 1 μ s | 10 microsecond | |
| 50 μ s | 5 μ s | 50 microsecond | |
| .1 ms | 10 μ s | 0.1 millisecond | |
| .2 ms | 10 μ s | 0.1 millisecond | |
| .5 ms | 50 μ s | 0.5 millisecond | |
| 1 ms | .1 ms | 1 millisecond | |
| 2 ms | .1 ms | 1 millisecond | ± 20 minor dial divisions ($\pm 2.5\%$) |
| 5 ms | .5 ms | 5 millisecond | |
| 10 ms | 1 ms | 10 millisecond | |
| 20 ms | 1 ms | 10 millisecond | |
| 50 ms | 5 ms | 50 millisecond | |
| .1 s | 10 ms | 0.1 second | |
| .2 s | 10 ms | 0.1 second | |
| .5 s | 50 ms | 0.5 second | |
| 1 s | .1 s | 1 second | |
| 2 s | .1 s | 1 second | |
| 5 s | .5 s | 5 second | |

switch to A INTEN DURING B and check which marker is intensified.

47. Check Delay Time Multiplier Incremental Linearity

REQUIREMENT—Within 0.2%.

- a. Change the following control settings:
 DELAY-TIME MULTIPLIER 9.00
 A TIME/DIV 1 ms
 B TIME/DIV 10 μ s

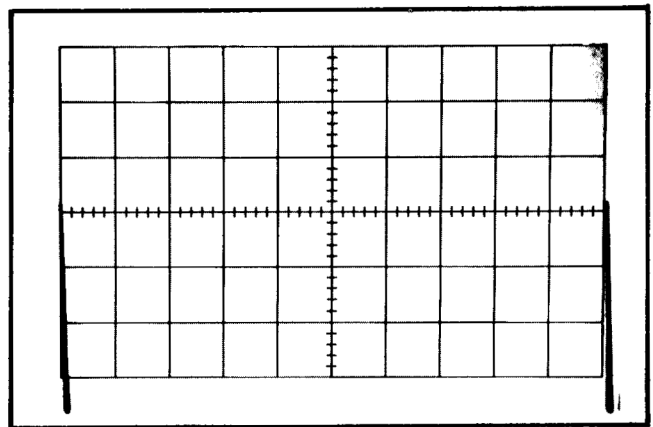

Fig. 5-20. Typical CRT display when checking delayed-sweep accuracy.

Performance Check—Type 454/R454

b. Set the time-mark generator for one-millisecond markers.

NOTE

If there were not exactly 8.00 dial divisions between 1.00 and 9.00 with the A TIME/DIV switch set to 1 ms as measured in step 46, use parts c through k to compensate for this error. Then the incremental linearity of the DELAY-TIME MULTIPLIER dial can be read directly from the dial. If the difference was exactly eight divisions, proceed to part m.

c. Set the A TIME/DIV switch to .5 ms; then return the B TIME/DIV switch to 10 μ s.

d. Set the HORIZ DISPLAY switch to A.

e. Set the A VARIABLE control for one marker each division between the first- and ninth-division vertical lines.

f. Set the HORIZ DISPLAY switch to B (DELAYED SWEEP).

g. Set the DELAY-TIME MULTIPLIER dial to 1.00 and rotate slightly until a marker is displayed at the start of the sweep. Note the dial reading.

h. Set the DELAY-TIME MULTIPLIER dial exactly 8.00 dial divisions higher than the reading in part g.

i. Turn the A VARIABLE control slightly so a marker is displayed at the start of the sweep.

j. Set the HORIZ DISPLAY switch to A INTEN DURING B and check for nine markers between the DELAY-TIME MULTIPLIER dial positions of 1.00 and 9.00.

k. Return the HORIZ DISPLAY switch to B (DELAYED SWEEP) and repeat parts g through j until the difference between the markers at about 1.00 and 9.00 is exactly 8.00 dial divisions.

l. Set the DELAY-TIME MULTIPLIER dial to 9.00.

m. Rotate the DELAY-TIME MULTIPLIER dial slightly so a marker is displayed at the start of the sweep (see Fig. 5-21).

n. Note the exact DELAY-TIME MULTIPLIER dial reading at 9.00.

o. Set the DELAY-TIME MULTIPLIER dial to 8.00.

p. CHECK—Dial reading should be $8.00 \pm$ two minor dial divisions (within 0.2%). Take into account the basic dial error at 9.00.

q. Repeat check at each major dial division between 8.00 and 1.00.

48. Check Delay-Time Jitter

REQUIREMENT—One part or less in 20,000.

a. Change the following control settings:

| | |
|-----------------------|-----------|
| DELAY-TIME MULTIPLIER | 1.00 |
| A TIME/DIV | 1 ms |
| B TIME/DIV | 1 μ s |
| A VARIABLE | CAL |

b. Position the pulse near the center of the display area with the DELAY-TIME MULTIPLIER dial.

c. CHECK—Jitter on the leading edge of the pulse should not exceed 0.5 division (1 part in 20,000); see Fig. 5-22. Disregard slow drift.

d. Turn the DELAY-TIME MULTIPLIER dial to 9.00 and adjust so the pulse is displayed near the center of the display area.

e. CHECK—Jitter on leading edge of the pulse should not exceed 0.5 division; see Fig. 5-22. Disregard slow drift.

49. Check Magnifier Register

REQUIREMENT—Less than 0.2-division shift when switching MAG switch from $\times 10$ to OFF.

a. Set the time-mark generator for five-millisecond markers.

b. Change the following control settings:

| | |
|---------------|-------------|
| HORIZ DISPLAY | A |
| MAG | $\times 10$ |

c. Position the middle marker (three markers on total sweep) to the center vertical line with the horizontal POSITION and FINE controls (see Fig. 5-23A).

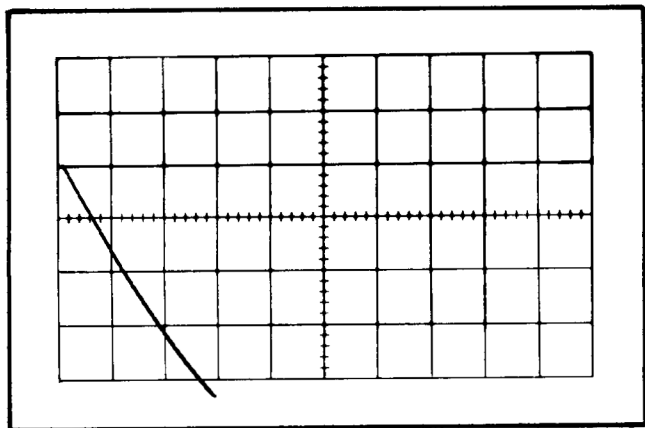

Fig. 5-21. Typical CRT display when checking DELAY-TIME MULTIPLIER dial incremental linearity.

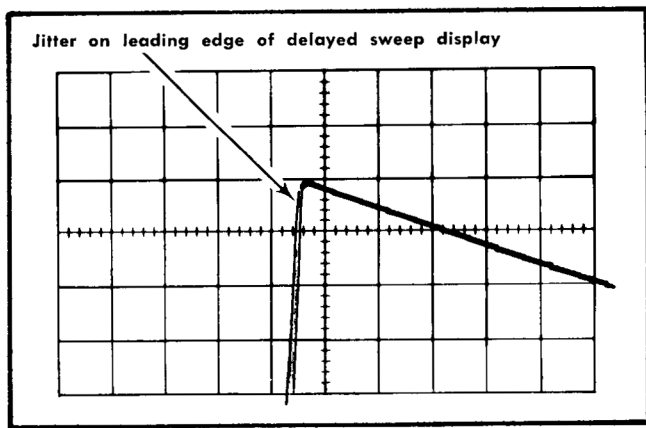

Fig. 5-22. Typical CRT display when checking delay-time jitter.

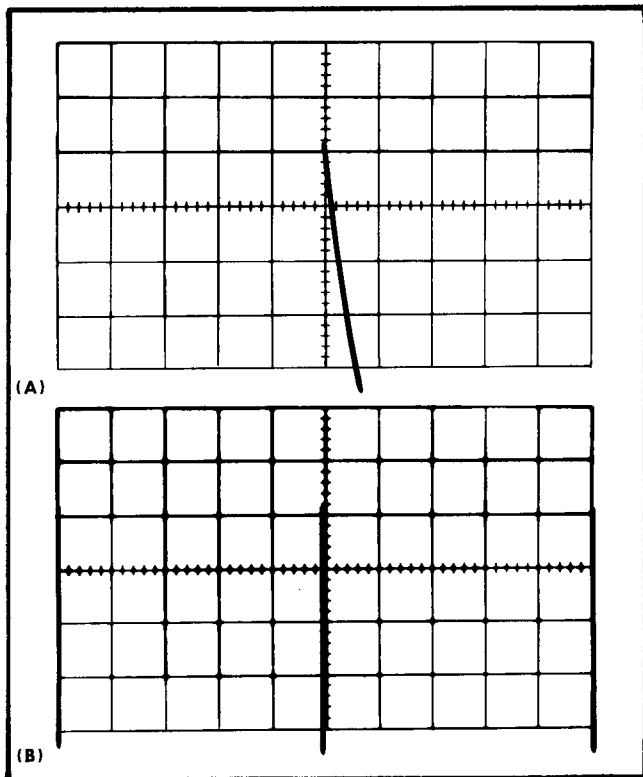

Fig. 5-23. Typical CRT display showing correct magnifier registration. (A) MAG switch set to $\times 10$, (B) MAG switch set to OFF.

d. Set the MAG switch to OFF.

e. CHECK—Trace shift less than 0.2 division (see Fig. 5-23B).

50. Check A Sweep Length

REQUIREMENT—Variable from four divisions, or less, to 11.0 divisions, ± 0.5 division.

a. Set the time-mark generator for 1- and 0.1-millisecond markers.

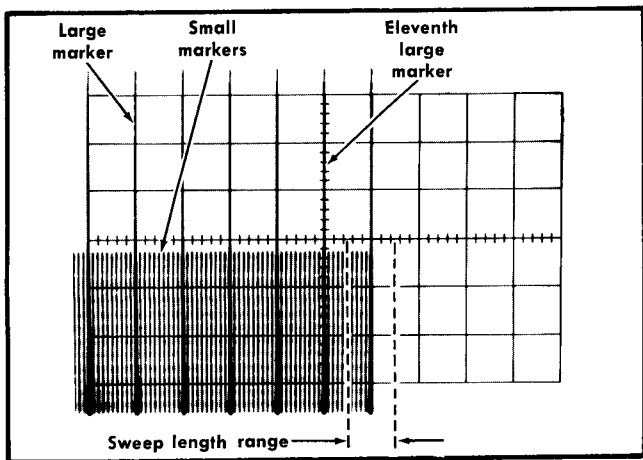

Fig. 5-24. Typical CRT display when checking A and B sweep length.

b. Set the A LEVEL control for a stable display.

c. Move the eleventh marker to the center vertical line with the horizontal POSITION control (see Fig. 5-24). Large markers indicate divisions and small markers indicate 0.1 division.

d. CHECK—A Sweep length must be between 10.5 and 11.5 divisions as shown by 0.5 to 1.5 divisions of display to the right of the center vertical line (see Fig. 5-24).

e. Reposition the first marker to the left graticule line.

f. Turn the A SWEEP LENGTH control to 4 DIV (not in B ENDS A detent).

g. CHECK—A Sweep length must be four divisions or less.

51. Check B Sweep Length

REQUIREMENT—11.0 divisions, ± 0.5 division.

a. Change the following control settings:

| | |
|-----------------------|------------------------------|
| DELAY-TIME MULTIPLIER | 0.10 |
| A TIME/DIV | 2 ms |
| B TIME/DIV | 1 ms |
| B SWEEP MODE | TRIGGERABLE AFTER DELAY TIME |
| HORIZ DISPLAY | B (DELAYED SWEEP) |
| A SWEEP LENGTH | FULL |

b. Set the time-mark generator for 1- and 0.1-millisecond markers.

c. Adjust the B LEVEL control for a stable display.

d. Move the eleventh large marker to the center vertical line with the horizontal POSITION control (see Fig. 5-24).

e. CHECK—B Sweep length must be between 10.5 and 11.5 divisions as shown by 0.5 to 1.5 divisions of display to the right of the center vertical line (see Fig. 5-24).

52. Check B Ends A Operation

REQUIREMENT—A Sweep ends immediately after the end of B sweep when the A SWEEP LENGTH control is set to B ENDS A.

a. Change the following control settings:

| | |
|----------------|---------------------------|
| A TIME/DIV | 1 ms |
| B TIME/DIV | .1 ms |
| B SWEEP MODE | B STARTS AFTER DELAY TIME |
| HORIZ DISPLAY | A INTEN DURING B |
| A SWEEP LENGTH | B ENDS A |

b. Rotate the DELAY-TIME MULTIPLIER dial throughout its range.

c. CHECK—CRT display ends after the intensified portion at all DELAY-TIME MULTIPLIER dial settings.

53. Check A Variable Control Range

REQUIREMENT—Continuously variable sweep rate between calibrated A TIME/DIV switch settings.

a. Change the following control settings:

| | |
|-----------------------|------|
| DELAY-TIME MULTIPLIER | 0.10 |
| B TIME/DIV | 1 ms |
| HORIZ DISPLAY | A |
| A SWEEP LENGTH | FULL |

b. Set the time-mark generator for 10-millisecond markers.

c. Set the A LEVEL control for a stable display.

d. Position the markers to the far left and right graticule lines with the horizontal POSITION control.

e. Turn the A VARIABLE control fully counterclockwise.

f. CHECK—CRT display for four-divisions maximum spacing between markers (indicates adequate range for continuously variable sweep rate between the calibrated steps; see Fig. 5-25). UNCAL A OR B light must be on when A VARIABLE control is not in CAL position.

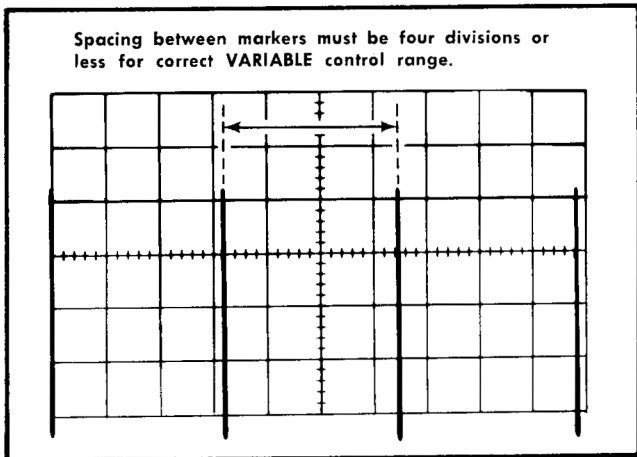

Fig. 5-25. Typical CRT display when checking A and B VARIABLE control range.

54. Check B Variable Control Range

REQUIREMENT—Continuously variable sweep rate between calibrated B TIME/DIV switch settings.

a. Change the following control settings:

| | |
|---------------|------------------------------|
| A TIME/DIV | 5 ms |
| B TIME/DIV | 1 ms |
| A VARIABLE | CAL |
| B SWEEP MODE | TRIGGERABLE AFTER DELAY TIME |
| HORIZ DISPLAY | B (DELAYED SWEEP) |

b. Position markers to the far left and right graticule lines with the horizontal POSITION control.

c. Turn the B TIME/DIV VARIABLE control (on side panel) fully counterclockwise.

d. CHECK—CRT display for four-division maximum spacing between markers (indicates adequate range for continuously variable sweep rate between the calibrated steps; see Fig. 5-25). UNCAL A OR B light must be on when B VARIABLE control is not in CAL position.

55. Check X Gain

REQUIREMENT—Correct horizontal deflection for X-Y mode operation in the 20 mV CH 1 VOLTS/DIV switch position.

a. Change the following control settings:

| | |
|---------------|------------------|
| VOLTS/DIV | 20 mV |
| TRIGGER | CH 1 ONLY OR X-Y |
| HORIZ DISPLAY | X-Y |

b. Connect the standard amplitude calibrator to the INPUT CH 1 connector with the 42-inch BNC cable.

c. Set the standard amplitude calibrator for a 0.1-volt square-wave output.

d. Increase the INTENSITY control setting until the display (two dots about five divisions apart) is visible.

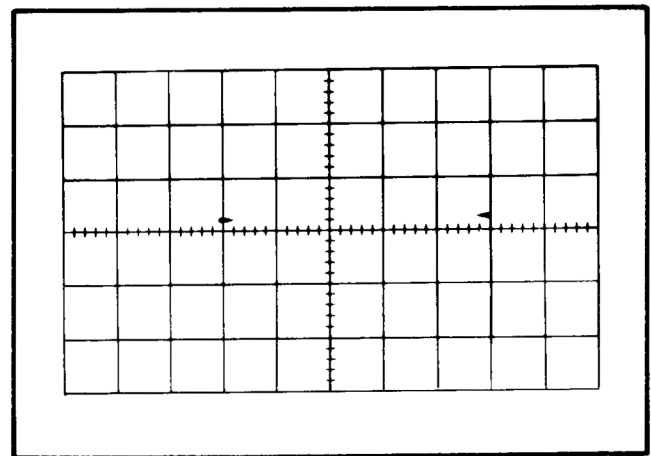

Fig. 5-26. Typical CRT display showing correct X Gain.

e. Move the display to the center of the graticule with the CH 1 POSITION control.

f. CHECK—CRT display for five divisions horizontal deflection, (see Fig. 5-26).

g. If necessary, adjust the X-GAIN adjustment (on side panel) for exactly five divisions horizontal deflection.

h. Disconnect all test equipment.

56. Check X-Y Phasing

REQUIREMENT— $\pm 3^\circ$ or less phase shift up to two megahertz.

a. Connect the medium-frequency constant-amplitude sine-wave generator to the INPUT CH 1 and INPUT CH 2

connectors through the five-nanosecond GR cable, 50-ohm in-line termination and the dual-input coupler.

b. Change the following control settings:

| | |
|----------------|-------|
| CH 1 VOLTS/DIV | 10 mV |
| CH 2 VOLTS/DIV | 50 mV |

c. Set the medium-frequency generator for a 10-division horizontal display at two megahertz.

d. Center the display vertically and horizontally with the CH 1 and CH 2 POSITION controls.

e. CHECK—CRT display for an opening at the center horizontal line of 0.52 division or less (3° or less phase shift; see Fig. 5-27).

f. Set the medium-frequency generator for a 10-division horizontal display at one megahertz.

g. If necessary, recenter the display with the CH 1 and CH 2 POSITION controls.

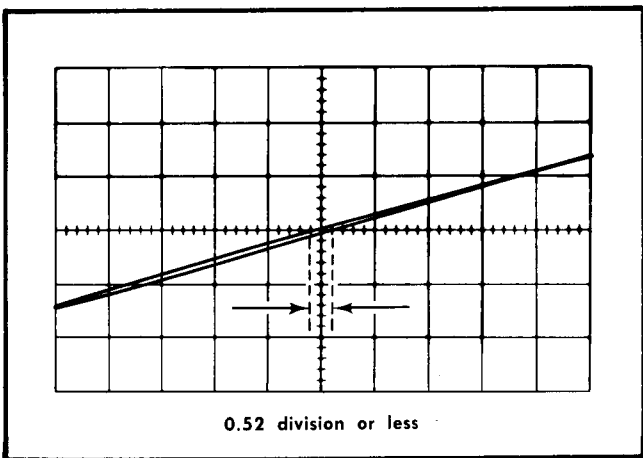

Fig. 5-27. Typical CRT display when checking X-Y phasing.

h. CHECK—CRT display for an opening at the center horizontal line of 0.52 division or less (3° or less phase shift; see Fig. 5-27).

i. Set the constant-amplitude generator for a 10-division horizontal display at 0.5 megahertz.

j. If necessary, recenter the display with the CH 1 and CH 2 POSITION controls.

k. CHECK—CRT display for maximum opening at the center horizontal line of 0.52 division or less (3° or less phase shift; see Fig. 5-27).

57. Check X Bandwidth in X-Y Mode

REQUIREMENT—Not more than -3 dB at two megahertz.

a. Disconnect the dual-input coupler from the INPUT CH 2 connector.

b. Set the medium-frequency generator for a six-division horizontal display at its reference frequency (50 kHz).

c. Set the generator to its variable frequency position.

d. Without changing the output amplitude, increase the output frequency of the generator until the horizontal deflection is reduced to 4.2 divisions (-3 dB point; see Fig. 5-28).

e. CHECK—Output frequency of generator must be two megahertz or higher.

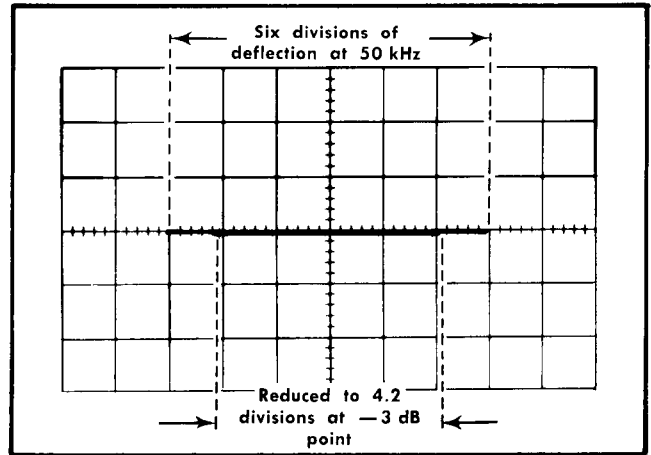

Fig. 5-28. Typical CRT display when checking X-Y bandwidth (double exposure).

58. Check Beam Finder Operation

REQUIREMENT—Display remains within graticule area when BW-BEAM FINDER switch is in the BEAM FINDER position regardless of the deflection factor or POSITION control settings.

a. Reconnect the dual-input coupler to the INPUT CH 2 connector.

b. While holding the BW-BEAM FINDER switch down, rotate the CH 1 and CH 2 POSITION controls and CH 1 and CH 2 VOLTS/DIV switches throughout their range.

c. CHECK—CRT display remains within the graticule area.

d. While holding the BW-BEAM FINDER switch down, adjust the positioning controls until the display is centered about the graticule center lines. Then, increase the X and Y deflection factors until the display is reduced to about two divisions vertically and about four divisions horizontally.

e. Release the BW-BEAM FINDER switch.

f. CHECK—CRT display must remain within the graticule area.

g. Reduce the INTENSITY control to a normal setting.

h. Disconnect all test equipment.

59. Check Chopped Operation

REQUIREMENT—Chopped repetition rate, one megahertz $\pm 20\%$; time segment from each channel, 416 to 625 nanoseconds; switching transients blanked out.

Performance Check—Type 454/R454

- Change the following control settings:

| | |
|---------------------|------------|
| MODE | CHOP |
| TRIGGER | NORM |
| A and B TIME/DIV | .2 μ s |
| HORIZ DISPLAY | A |
| B TIME/DIV VARIABLE | CAL |
- Position the traces about four divisions apart.
- Set the A LEVEL control for a stable display.
- CHECK—Each cycle for duration of 4.2 to 6.25 divisions (one megahertz, $\pm 20\%$; see Fig. 5-29).
- CHECK—Length of each segment between 2.1 and 3.1 divisions (416 to 625 nanoseconds; see Fig. 5-29).
- CHECK—CRT display for complete blanking of switching transients between chopped segments (see Fig. 5-29).

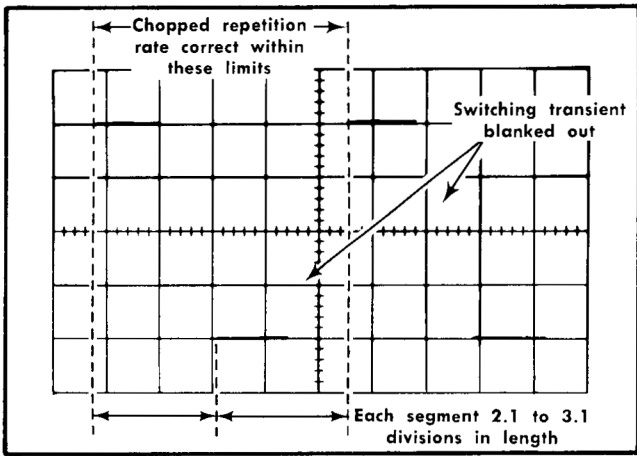

Fig. 5-29. Typical CRT display when checking chopped repetition rate and blanking.

60. Check Calibrator Repetition Rate

REQUIREMENT—One kilohertz, $\pm 0.5\%$.

- Change the following control settings:

| | |
|------------------|-------|
| CH 1 VOLTS/DIV | .5 |
| CH 2 VOLTS/DIV | .2 |
| MODE | ALT |
| A and B TIME/DIV | .1 ms |
- Connect the 1 V CAL 1 kHz connector to the INPUT CH 1 connector with an 18-inch 50-ohm BNC cable.
- Connect the time-mark generator to the INPUT CH 2 connector through a 42-inch 50-ohm BNC cable and a 50-ohm BNC termination.
- Set the time-mark generator for one-millisecond markers.
- Position the display so the tips of the markers fall just below the rising portions of the square wave (see Fig. 5-30).
- Set the A LEVEL control so both waveforms start at the same point.
- Position the rising portion of the second calibrator cycle to the center vertical line.

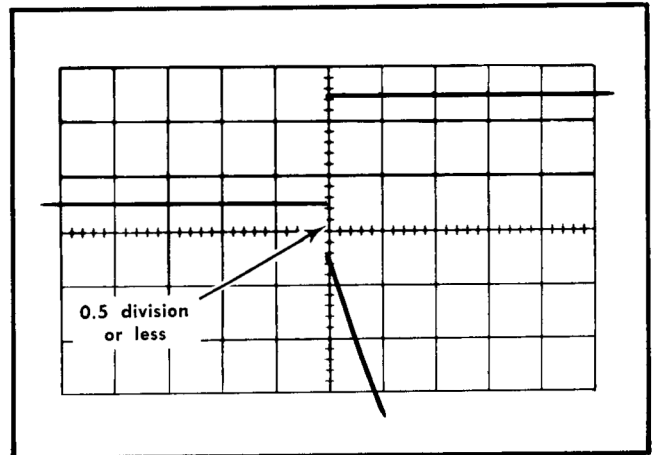

Fig. 5-30. Typical CRT display showing correct calibrator repetition rate.

- Set the MAG switch to $\times 10$.
- CHECK—Separation between Calibrator waveform leading edge and the marker leading edge not to exceed 0.5 division (0.5% accuracy; see Fig. 5-30).
- Disconnect the time-mark generator.

61. Check Calibrator Duty Cycle

REQUIREMENT—49% to 51%.

- Change the following control settings:

| | |
|----------------|------|
| CH 1 VOLTS/DIV | .2 |
| MODE | CH 1 |
| MAG | OFF |
- Center the display vertically with the CH 1 POSITION control.
- Set the A LEVEL control so the display starts at the 50% point on the rising portion of the waveform (the INTENSITY control may need to be advanced slightly to see the rising portion of the waveform).

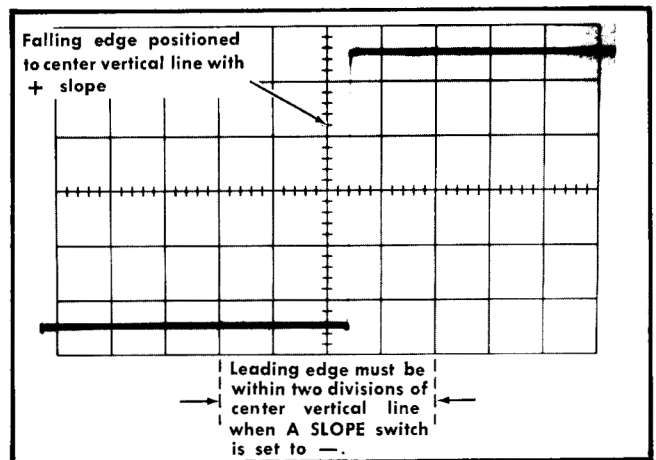

Fig. 5-31. Typical CRT display when checking calibrator duty cycle.

- d. Set the MAG switch to $\times 10$.
- e. Position the 50% point on the falling edge of the Calibrator waveform to the center vertical line.
- f. Set the A SLOPE switch to —.
- g. CHECK—50% point on rising edge now displayed not displaced more than two divisions from the center vertical line (duty cycle 49% to 51%; see Fig. 5-31).

62. Check Calibrator Risetime

REQUIREMENT—One microsecond or less.

- a. Change the following control settings:

| | |
|------------------|------------|
| A SLOPE | + |
| A and B TIME/DIV | .2 μ s |
| MAG | OFF |
- b. Set the A LEVEL control so all of the rising portion of the Calibrator waveform is visible.
- c. Position the 10% point of the leading edge to a vertical graticule line.
- d. CHECK—CRT display for five divisions or less between the 10% and 90% points on the leading edge of the calibrator waveform (one microsecond, or less, risetime; see Fig. 5-32).

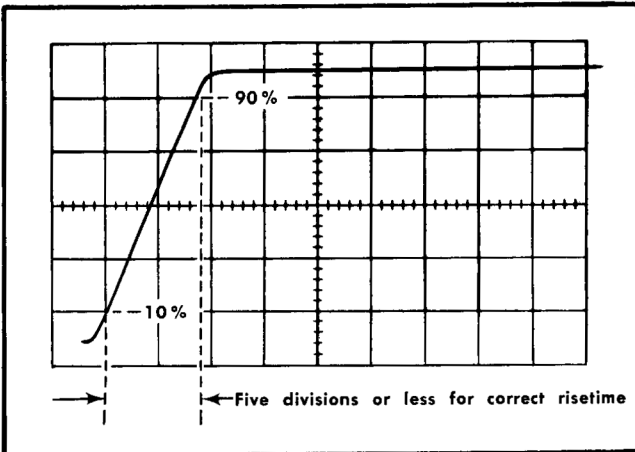

Fig. 5-32. Typical CRT display when checking calibrator risetime.

63. Check Calibrator Voltage Output

REQUIREMENT—One volt, $\pm 1\%$.

- a. Change the following control settings:

| | |
|------------------|------|
| CH 1 VOLTS/DIV | .1 |
| A SOURCE | LINE |
| A and B TIME/DIV | 5 ms |
- b. Connect the 1 V CAL 1 kHz connector to the unknown input connector of the standard amplitude calibrator with a 42-inch BNC cable.
- c. Set the standard amplitude calibrator for a positive, one-volt DC output in the mixed mode.

- d. Connect the standard amplitude calibrator output to the INPUT CH 1 connector.
- e. Set the A LEVEL control for a stable display.
- f. Position the top of the waveform on the display area with the CH 1 POSITION control.
- g. CHECK—Difference between the standard amplitude calibrator output level and the Type 454 calibrator output 0.1 division or less (one volt, $\pm 1\%$; see Fig. 5-33).
- h. Disconnect all test equipment.

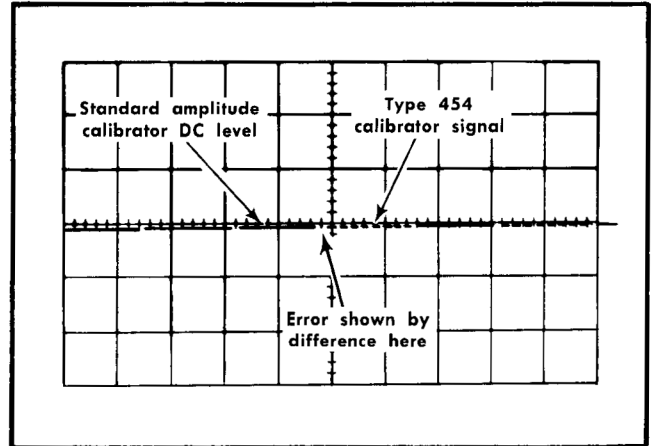

Fig. 5-33. Typical CRT display when checking voltage output of calibrator.

64. Check Current through Current Probe Cal Loop

REQUIREMENT—Five milliamperes.

- a. Connect the current-measuring probe and passive termination to the INPUT CH 1 connector.
- b. Set the passive termination for a sensitivity of 2 mA/mV.
- c. Clip the current-measuring probe around the CURRENT PROBE CAL loop.
- d. Change the following control settings:

| | |
|------------------|-------|
| CH 1 VOLTS/DIV | 5 mV |
| A SOURCE | INT |
| A and B TIME/DIV | .5 ms |
- e. CHECK—CRT display 0.5 division in amplitude (five milliamperes; see Fig. 5-34).

NOTE

This step checks for the presence of current in the CURRENT PROBE CAL loop. This current will remain within the stated 1% accuracy due to the tolerance of the divider resistors and tolerance of the calibrator output voltage. If it is necessary to verify the accuracy of the calibrator current, use a current measuring meter with an accuracy of at least 0.25%.

- f. Disconnect all test equipment.

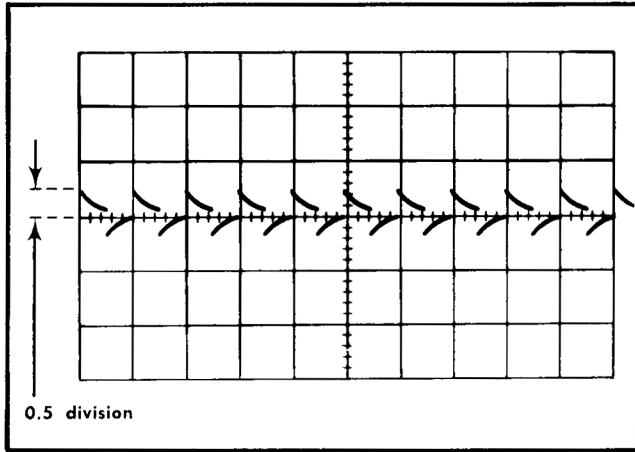

Fig. 5-34. Typical CRT display when checking calibrator current.

65. Check External Z Axis Operation

REQUIREMENT—Noticeable trace modulation with five-volt signal from DC to 50 megahertz or greater.

a. Change the following control settings:

| | |
|------------------|------------|
| A SOURCE | EXT |
| A and B TIME/DIV | 20 μ s |

b. Set the INTENSITY control to a normal setting.

c. Connect the medium-frequency generator to the A EXT TRIG INPUT connector through the five-nanosecond GR cable, 50-ohm in-line termination and BNC T connector. Connect the output of the BNC T connector to the Z AXIS INPUT binding posts through a 42-inch BNC cable and the BNC to alligator clip adapter. (Connect black lead of alligator clip adapter to ground post.)

d. Remove the ground strap from between the binding posts.

e. Set the medium-frequency generator for five-volt output at 50 kilohertz (use calibrated position of generator amplitude control).

f. CHECK—CRT display for noticeable intensity modulation (see Fig. 5-35A). The INTENSITY control setting may need to be reduced to view trace modulation.

g. Set the constant-amplitude generator for five-volt output at 50 megahertz (use calibrated position of generator amplitude control).

h. Set the A and B TIME/DIV switch to 0.05 μ s.

i. CHECK—CRT display for noticeable intensity modulation (see Fig. 5-35B). The INTENSITY control setting may need to be reduced to view trace modulation.

j. Disconnect all test equipment and replace ground strap.

66. Check A + Gate Output Signal

REQUIREMENT—Polarity, positive going; amplitude, 12.6 volts \pm 10%; duration, about 11 times the A TIME/DIV switch setting.

a. Set the A and B TIME/DIV switch to 1 ms. Be sure the A SWEEP LENGTH control is set to FULL.

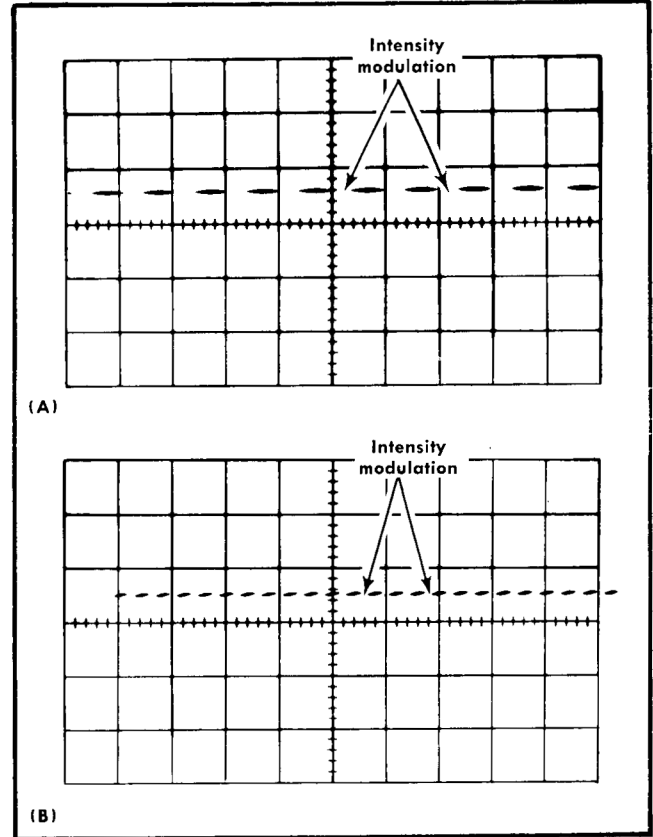

Fig. 5-35. (A) Typical CRT display when checking Z-axis operation at 50 kilohertz, (B) typical CRT display when checking Z-axis operation at 50 megahertz.

b. Connect the A + GATE connector (on side panel) to the test-oscilloscope input connector with the 42-inch BNC cable.

c. Set the test oscilloscope for a vertical deflection factor of five volts/division at a sweep rate of two milliseconds/division.

d. CHECK—Test-oscilloscope display for 2.5 divisions, \pm 0.25 division, vertical deflection with the bottom of the

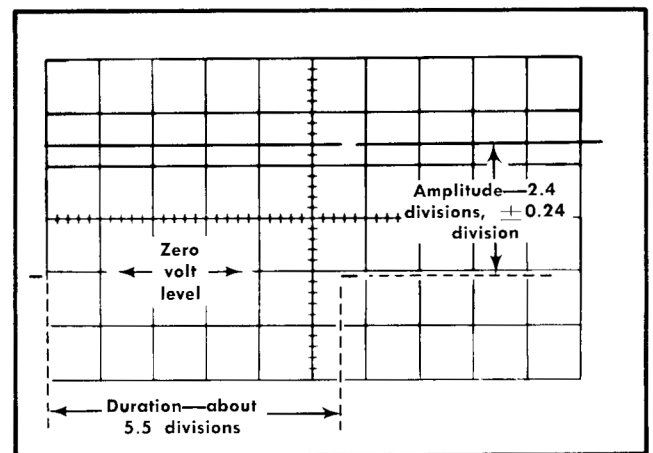

Fig. 5-36. Typical test oscilloscope display when checking A and B + GATE output amplitude and duration (vertical deflection factor, five volts/division; sweep rate, two milliseconds/division).

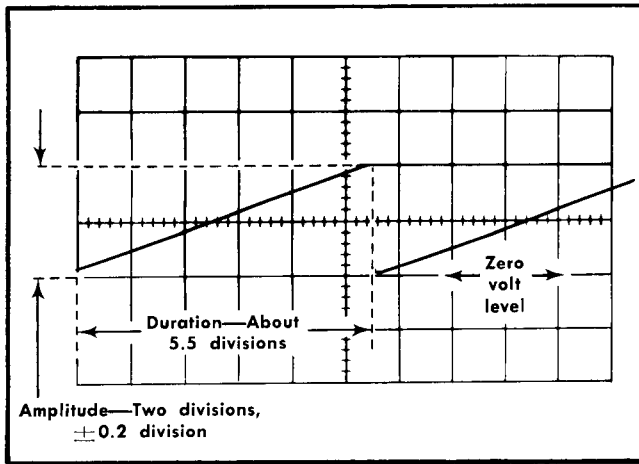

Fig. 5-37. Typical test oscilloscope display when checking A SWEEP output amplitude (vertical deflection factor, five volts/division; sweep rate, two milliseconds/division).

waveform about 0.1 division below the zero-volt level (12.6 volts $\pm 10\%$; see Fig. 5-36). Gate duration should be about 5.5 divisions (about 11 times the A TIME/DIV switch setting).

67. Check A Sweep Output Signal

REQUIREMENT—Polarity, positive going; amplitude, 10 volts $\pm 10\%$; duration, about 11 times the A TIME/DIV switch setting.

a. Connect the A SWEEP connector (on side panel) to the test oscilloscope input connector with the 42-inch BNC cable.

b. CHECK—Test oscilloscope display for a vertical deflection of two divisions, ± 0.2 division with the bottom of the waveform near the zero-volt level (10 volts $\pm 10\%$; see Fig. 5-37). Sweep duration should be about 5.5 divisions (about 11 times the A TIME/DIV switch setting).

68. Check B + Gate Output Signal

REQUIREMENT—Polarity, positive going; amplitude, 12.6 volts $\pm 10\%$; duration, about 11 times the B TIME/DIV switch setting.

a. Connect the B + GATE connector (on side panel) to the test-oscilloscope input connector with the 42-inch BNC cable.

b. Change the following control settings:

| | |
|-----------------------|-------------------|
| DELAY-TIME MULTIPLIER | 0.10 |
| A TIME/DIV | 2 ms |
| B TIME/DIV | 1 ms |
| HORIZ DISPLAY | B (DELAYED SWEEP) |

c. CHECK—Test oscilloscope display for 2.5 divisions, ± 0.25 division, vertical deflection with the bottom of the waveform about 0.1 duration below the zero-volt level (12.6 volts $\pm 10\%$; see Fig. 5-36). Gate duration should be about 5.5 divisions (about 11 times the B TIME/DIV switch setting).

This completes the performance check procedure for the Type 454. If the instrument has met all performance requirements given in this procedure, it is correctly calibrated and within the specified tolerances.

SECTION 6

CALIBRATION

Introduction

Complete calibration information for the Type 454 is given in this section. Performing the complete procedure returns this instrument to original performance standards. Limits, tolerances and waveforms in this procedure are given as calibration guides and are not instrument specifications. If it is desired to merely touch up the calibration perform only those steps entitled "Adjust . . .". A short-form calibration procedure is also provided in this section for the convenience of the experienced calibrator.

The Type 454 should be checked, and recalibrated if necessary, after each 1000 hours of operation, or every six months if used infrequently, to assure correct operation and accuracy. The Performance Check section of this manual provides a complete check of instrument performance without making internal adjustments. Use the Performance Check procedure to verify the calibration of the Type 454 and determine if recalibration is required.

TEST EQUIPMENT REQUIRED

General

The following test equipment, or its equivalent, is required for complete calibration of the Type 454 (see Figs. 6-1 and 6-2). Specifications given are the minimum necessary for accurate calibration of this instrument. All test equipment is assumed to be correctly calibrated and operating within the given specifications. If equipment is substituted, it must meet or exceed the specifications of the recommended equipment.

For the quickest and most accurate calibration, special calibration fixtures are used where necessary. These special calibration fixtures are available from Tektronix, Inc. Order by part number through your local Tektronix Field Office or representative.

1. Variable autotransformer. Must be capable of supplying 200 volt-amperes over a range of 90 to 136 volts (180 to 272 volts for 230-volt nominal line). (If autotransformer does not have an AC voltmeter to indicate output voltage, monitor the output with an AC voltmeter with range of at least 136 or 272 volts, RMS.) For example, General Radio W10MT3W Metered Variac Autotransformer (note that the full current capabilities of this unit are not required).
2. Precision DC voltmeter. Accuracy, within $\pm 0.05\%$; meter resolution, 50 microvolts; range, zero to two kilovolts. For example, Fluke Model 825A Differential DC Voltmeter (use Fluke Model 80E-2 Voltage Divider to measure voltages above 500 volts).
3. Test Oscilloscope. Bandwidth, DC to 50 MHz; minimum deflection factor, five millivolts/division; accuracy, within 3%. Tektronix Type 453 or Type 454 Oscilloscope recommended.
4. $1\times$ probe with BNC connector. Tektronix P6011 Probe recommended.
5. $10\times$ probe with BNC connector. Tektronix P6010 or P6047 recommended.
6. Time-mark generator. Marker outputs, five seconds to five nanoseconds; marker accuracy, within 0.1%. Tektronix Type 184 Time-Mark Generator recommended.
7. Standard amplitude calibrator. Amplitude accuracy, within 0.25%; signal amplitude, five millivolts to 50 volts; output signal, one-kilohertz square wave and positive DC voltage. Tektronix calibration fixture 067-0502-00 recommended.
8. Square-wave generator. Frequency, one kilohertz and one megahertz; risetime, one nanosecond or less from fast-rise output; output amplitude, about 120 volts unterminated or 12 volts into 50 ohms. Tektronix Type 106 Square-Wave Generator recommended.
9. Fast-rise, high-amplitude pulse generator. Risetime, 0.25 nanosecond or less; repetition rate, 550 to 720 pulses/second; amplitude, variable from 20 millivolts to ten volts. Tektronix Type 109 Pulse Generator recommended.
10. Charge line. Impedance, 50 ohms; electrical length, 60 nanoseconds; connectors, GR874. Tektronix Type 113 Delay Cable recommended.
11. Signal insertion unit. Input connector, GR874 (Tektronix P6040 probe); output connectors, fits delay-line input jacks of Type 454; purpose, to adjust compensation of Vertical Output Amplifier. Tektronix Calibration Fixture 067-0553-00 and P6040 probe, Tektronix Part No. 010-0133-00 recommended.
12. Signal pickoff. Connectors, GR874 thru-signal connectors and BNC signal-pickoff connector. Tektronix Type CT-3 50 Ω Signal Pickoff recommended (Tektronix Part No. 017-0061-00).
13. High-frequency constant-amplitude sine-wave generator. Frequency, 65 megahertz to above 150 megahertz; reference frequency, three megahertz; output amplitude, variable from 0.5 volt to five volts; amplitude accuracy, within 1% at three megahertz and from 65 megahertz to 150 megahertz. Tektronix calibration fixture 067-0532-00 recommended.
14. Medium-frequency constant-amplitude sine-wave generator. Frequency, 350 kilohertz to 100 megahertz; reference frequency, 50 kilohertz; output amplitude, variable from five millivolts to five volts into 50 ohms or 10 volts unterminated; amplitude accuracy, within 3% at 50 kilohertz and from 350 kilohertz to 100 megahertz. Tektronix Type 191 Constant Amplitude Signal Generator recommended.
15. Low-frequency sine-wave generator. Frequency, 10 hertz to 100 kilohertz; output amplitude, variable from 0.5 volts to 40 volts peak to peak; amplitude accuracy, within 3% from 10 hertz to 100 kilohertz. For example, General Radio 1310-A Oscillator (use a General Radio Type 274QBJ Adaptor to provide BNC output).

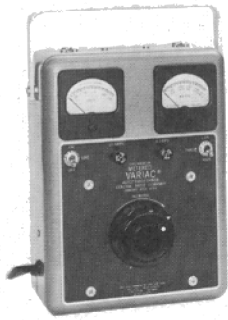

(1)



(2)



(3)

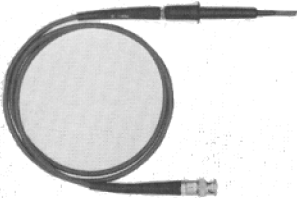

(4)

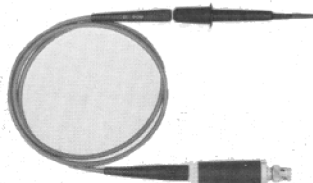

(5)



(6)



(7)



(8)



(9)

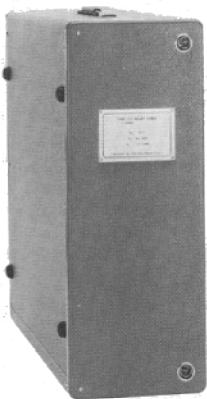

(10)

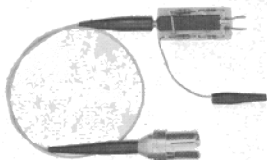

(11)

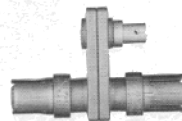

(12)

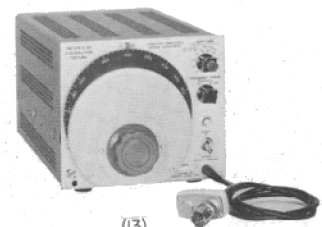

(13)

Fig. 6-1A. Recommended calibration equipment. Items 1 through 13.

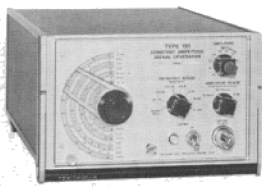

(14)



(15)

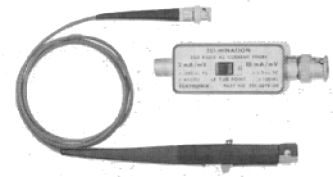

(16)

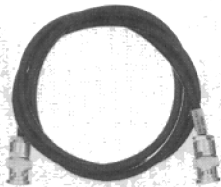

(17)

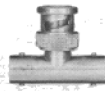

(18)



(19)



(20)



(21)



(22)



(23)



(24)



(25)



(26)



(27)



(28)



(29)

Fig. 6-1B. Recommended calibration equipment. Items 14 through 29.

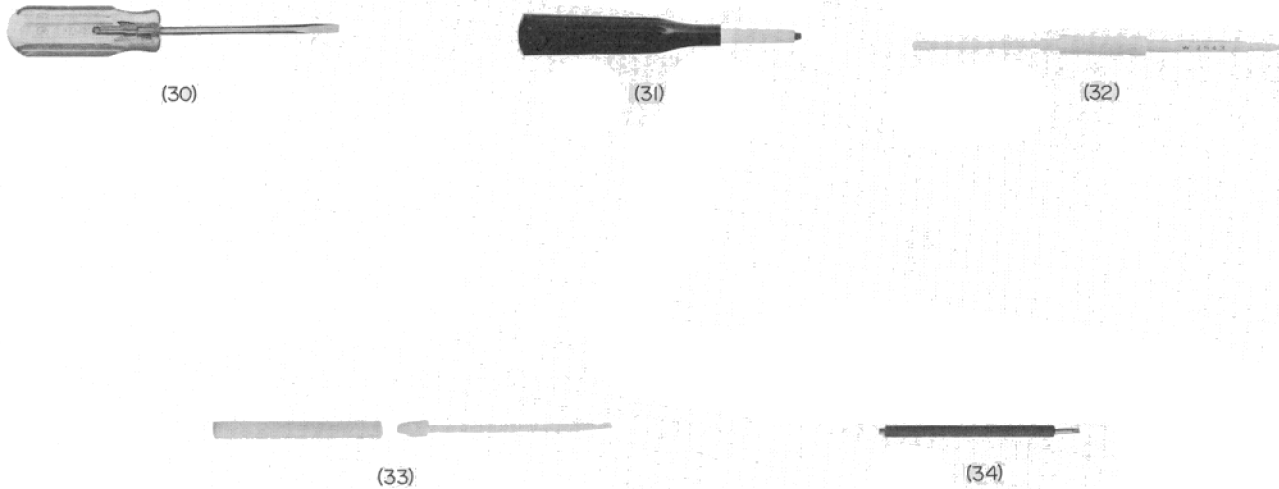

Fig. 6-2. Recommended calibration equipment. Items 30 through 34.

16. Current-measuring probe with passive termination. Sensitivity, two milliamperes/millivolt; accuracy, within 3%. Tektronix P6019 Current Probe with 011-0078-00 passive termination recommended.

17. Cable (two). Impedance, 50 ohms; type, RG-58/U; length, 42 inches; connectors, BNC. Tektronix Part No. 012-0057-00.

18. BNC T connector. Tektronix Part No. 103-0030-00.

19. Cable. Impedance, 50 ohms; type RG-58/U; length, 18 inches; connectors, BNC. Tektronix Part No. 012-0076-00.

20. Cable (two). Impedance, 50 ohms; type RG-213/U; electrical length, five nanoseconds; connectors, GR874. Tektronix Part No. 017-0502-00

21. In-line termination. Impedance, 50 ohms; wattage rating, two watts; accuracy, $\pm 3\%$; connectors, GR874 input with BNC male output. Tektronix Part No. 017-0083-00.

22. Input RC normalizer. Time constant, 1 megohm \times 20 pF; attenuation, 2 \times ; connectors, BNC. Tektronix calibration fixture 067-0538-00.

23. 5 \times attenuator. Impedance, 50 ohms; accuracy, $\pm 3\%$; connectors, GR874. Tektronix Part No. 017-0079-00.

24. 10 \times attenuator. Impedance, 50 ohms; accuracy, $\pm 3\%$; connectors, GR874. Tektronix Part No. 017-0078-00.

25. Dual-input coupler. Matched signal transfer to each input. Tektronix calibration fixture 067-0525-00.

26. Adapter. Adapts GR874 connector to BNC female connector. Tektronix Part No. 017-0064-00.

27. Termination. Impedance, 50 ohms; accuracy, $\pm 3\%$; connectors, BNC. Tektronix Part No. 011-0049-00.

28. 5 \times attenuator. Impedance, 50 ohms; accuracy, $\pm 3\%$; connectors, BNC. Tektronix Part No. 011-0060-00.

29. Adapter. Connectors, BNC female and two alligator clips. Tektronix Part No. 013-0076-00.

30. Screwdriver. Three-inch shaft. Tektronix Part No. 003-0192-00.

31. Low-capacitance screwdriver. 1 1/2-inch shaft. Tektronix Part No. 003-0000-00.

32. Tuning rod. Five-inch, for 0.100-inch (ID) hex slugs. Tektronix Part No. 003-0301-00.

33. Tuning tool. Handle and insert for 5/64-inch (ID) hex cores. Tektronix Part Nos. 003-0307-00 and 003-0310-00.

34. Capacitor tuning tool. Four-inch with slotted head. Tektronix Part No. 003-0496-00.

35. Elbow (not shown). Impedance, 50 ohms; connectors, GR874. Tektronix Part No. 017-0070-00.

36. Short-circuit termination (not shown). Connector, GR874. Tektronix Part No. 017-0087-00.

Short-Form Calibration Procedure

This short-form calibration procedure is provided to aid in checking the operation of the Type 454. It may be used as a calibration guide by the experienced calibrator, or it may be used as a record of calibration. Since the step numbers and titles used here correspond to those used in the complete procedure, this procedure also serves as an index to locate a step in the complete Calibration Procedure. Performance requirements correspond to those given in Section 1 of this manual.

Type 454, Serial No. _____

Calibration Date _____

Calibrated by _____

- | | |
|--|---|
| <ul style="list-style-type: none"> <input type="checkbox"/> 1. Adjust —12-Volt Power Supply (R1124). Page 6-9 —12 volts, ± 0.032 volt. <input type="checkbox"/> 2. Adjust +12-Volt Power Supply (R1158). Page 6-10 Adjust for +1 volt, ± 0.003 volt, at 1 V CAL 1 kHz connector with Q1275 removed. Check for +12.0 to +12.2 volts output from supply. <input type="checkbox"/> 3. Adjust +75-Volt Power Supply (R1188). Page 6-10 +75 volts, ± 0.278 volt. <input type="checkbox"/> 4. Check Voltage at PROBE POWER Connectors. Page 6-11 +12 volts, —12 volts and ground at the correct terminals of the CH 1 and CH 2 PROBE POWER connectors. <input type="checkbox"/> 5. Adjust High-Voltage Supply and Check Regulation (R1401). Page 6-11 —1960 volts, ± 19.6 volts. Must remain within ± 58.8 volts of this output level over input line voltage range and INTENSITY control changes. <input type="checkbox"/> 6. Adjust CRT Grid Bias (R1447). Page 6-11 See procedure. <input type="checkbox"/> 7. Check Low Voltage Power-Supply Ripple. Page 6-13 Two millivolts peak-to-peak maximum ripple on the —12-, +12- and +75-volt supplies. <input type="checkbox"/> 8. Adjust Trace Alignment (R1480). Page 6-14 Trace parallel to horizontal graticule lines. <input type="checkbox"/> 9. Adjust Astigmatism (R1489). Page 6-15 Sharp, well-defined display. <input type="checkbox"/> 10. Adjust Y Axis Alignment (R1485). Page 6-16 Markers parallel to the center vertical line within 0.1 division. <input type="checkbox"/> 11. Adjust CRT Geometry (R1482). Page 6-16 Bowing or tilt of markers at left and right extremes of display ± 0.1 division or less. | <ul style="list-style-type: none"> <input type="checkbox"/> 12. Adjust Channel 1 and 2 Step Attenuator Balance (R21, R28, R121, R128). Page 6-16 0.1 division, or less, trace shift as VOLTS/DIV switch is changed from 20 mV to 5 mV. 0.1 division, or less, trace shift as VOLTS/DIV switch is changed from 50 mV to .1. <input type="checkbox"/> 13. Adjust Vertical Centering (R334). Page 6-17 Correct operation; see procedure. <input type="checkbox"/> 14. Adjust Channel 1 and 2 Position Centering (R40, R140). Page 6-18 Trace at center horizontal line with CH 1 and CH 2 POSITION controls centered. <input type="checkbox"/> 15. Adjust Channel 1 and 2 Gain and Output Amplifier Gain (R67, R167, R365). Page 6-20 Correct vertical deflection in the 20 mV positions of the CH 1 and CH 2 VOLTS/DIV switches. <input type="checkbox"/> 16. Check Added Mode Operation. Page 6-21 Correct signal addition within 3%. <input type="checkbox"/> 17. Check Channel 1 and 2 Deflection Accuracy. Page 6-21 Vertical deflection within 3% of CH 1 and CH 2 VOLTS/DIV switch indication. <input type="checkbox"/> 18. Check Channel 1 and 2 Variable Volts/Division Range. Page 6-22 Continuously variable deflection factor between the calibrated steps. <input type="checkbox"/> 19. Check Channel 1 and 2 Cascaded Deflection Factor. Page 6-22 One millivolt/division or less. <input type="checkbox"/> 20. Check Channel 1 and 2 Input Coupling Switch Operation. Page 6-22 Correct signal coupling in each position of the CH 1 and CH 2 Input Coupling switches. <input type="checkbox"/> 21. Check Low-Frequency Vertical Linearity. Page 6-23 0.1 division, or less, compression or expansion of a two-division signal (at center screen) when positioned to the vertical extremes of the graticule area. <input type="checkbox"/> 22. Check Trace Shift Due to Input Grid Current. Page 6-23 0.4 division or less at 5 mV/DIV. <input type="checkbox"/> 23. Check Alternate Operation. Page 6-23 Trace alternation at all sweep rates. <input type="checkbox"/> 24. Adjust Channel 1 Volts/Division Switch Compensation (C5A, C5D, C6A, C6E, C9). Page 6-24 Optimum Channel 1 square-wave response. <input type="checkbox"/> 25. Adjust Channel 2 Volts/Division Switch Compensation (C105A, C105D, C106A, C106E, C109). Page 6-25 Optimum Channel 2 square-wave response. |
|--|---|

Calibration—Type 454/R454

- 26. Adjust Delay-Line Termination and Compensation (C402, R417, R419). Page 6-26
Minimum aberrations in the area about 280 nanoseconds after the rising portion of a step function and optimum square-wave response.
- 27. Adjust Output Amplifier High-Frequency Compensation (C353, C426, L394, L494, R353, R382, R394, R426, R494). Page 6-27
Correct bias on Q474 and optimum square-wave response with Vertical Output Amplifier driven directly through delay line.
- 28. Adjust Channel 1 High-Frequency Compensation (C25, C43, C45, C49A, C49F, C49H, C49J, C49N, C60, C78, R44, R49A, R49G, R49H, R49N). Page 6-29
Optimum square-wave response.
- 29. Adjust Channel 2 High-Frequency Compensation (C125, C143, C145, C149A, C149F, C149H, C149J, C149N, C160, C178, R149A, R149G, R149H, R149N). Page 6-31
Optimum square-wave response.
- 30. Check 0.1 volt, 50 mV, 20 mV and 10 mV Bandwidth of Channel 1 and 2. Page 6-33
0.1 volt, 50 mV and 20 mV; not more than -3 dB at 150 megahertz; 10 mV; not more than -3 dB at 100 megahertz.
- 31. Check Added Mode Bandwidth. Page 6-35
Not more than -3 dB at 150 megahertz.
- 32. Check 5 mV Bandwidth of Channel 1 and 2. Page 6-35
Not more than -3 dB at 60 megahertz.
- 33. Check Channel 1 and 2 Cascaded Bandwidth. Page 6-35
Not more than -3 dB at 33 megahertz.
- 34. Check Bandwidth Limiter Operation. Page 6-35
Not more than -3 dB at four megahertz and not less than -3 dB at six megahertz.
- 35. Check Low-Frequency, AC Coupled width. Page 6-36
Not more than -3 dB at 10 hertz.
- 36. Check Common-Mode Rejection Ratio. Page 6-37
10:1 or greater at 50 megahertz.
- 37. Check Attenuator Isolation Ratio. Page 6-38
10,000:1 or greater at 50 megahertz.
- 38. Check Amplifier Crosstalk Ratio. Page 6-38
100:1 or greater, DC to 50 megahertz.
- 39. Adjust CH 1 OUT DC level (R52). Page 6-39
Zero volts with the trace centered.
- 40. Adjust A and B Trigger Level Centering (R643, R843). Page 6-40
Correct operation of trigger circuits; see procedure.
- 41. Adjust Trigger Preamp DC Level and Normal Trigger DC Level (R272, R511). Page 6-41
Correct operation of trigger circuits; see procedure.
- 42. Check A and B 20 Megahertz Triggering Operation. Page 6-41
Internal, stable display in AC, LF REJ and DC positions of A and B COUPLING switches with 0.3 division display; external, stable display in AC, LF REJ and DC positions of A and B COUPLING switches with 75-millivolt signal.
- 43. Check A and B 150 Megahertz Triggering Operation. Page 6-42
Internal, stable display in AC, LF REJ and DC positions of A and B COUPLING switches with 1.5-division signal; external, stable display in AC, LF REJ and DC positions of A and B COUPLING switches with 375-millivolt signal.
- 44. Check A and B Low-Frequency Triggering Operation. Page 6-43
Internal, stable display in AC, HF REJ and DC positions of A and B COUPLING switches with 0.3-division display at 60 hertz; external, stable display in AC, HF REJ and DC positions of A and B COUPLING switches with 75-millivolt signal at 60 hertz.
- 45. Check A and B High-Frequency Reject Operation. Page 6-43
Stable display with 0.3-division display at 50 kilohertz; does not trigger at one megahertz.
- 46. Check A and B Low-Frequency Reject Operation. Page 6-44
Stable display with 0.3-division display at 30 kilohertz; does not trigger at 60 hertz.
- 47. Check Single Sweep Operation. Page 6-44
Sweep triggers at same A LEVEL control settings as in AUTO TRIG; after each sweep, further displays are locked out until the RESET button is pressed.
- 48. Check A and B Slope Switch Operation. Page 6-44
Stable triggering on correct slope of trigger signal.
- 49. Check A and B Triggering Level Control Range. Page 6-45
EXT, at least $+$ and $-$ 2 volts; EXT \div 10, at least $+$ and $-$ 20 volts.
- 50. Check Line Triggering Operation. Page 6-45
Stable display of line-frequency signal, triggered on the correct polarity.
- 51. Check Auto Recovery Time and Operation. Page 6-47
Stable display with 50-millisecond markers (20 hertz); free-running display with 0.1-second markers.
- 52. Adjust Sweep Start and A Sweep Calibration (R743, R956). Page 6-48
Correct operation of sweep circuits; see procedure.
- 53. Adjust Normal Gain (R1036). Page 6-49
Correct A sweep timing at 1 ms/DIV.

- 54. Adjust Magnified Gain (R1047). Page 6-49
Correct A sweep timing at 1 ms/DIV with the MAG switch set to $\times 10$.
- 55. Adjust Magnifier Register (R1053). Page 6-50
Less than 0.2-division shift when switching MAG switch from $\times 10$ to OFF.
- 56. Adjust B Sweep Calibration (R943). Page 6-50
Correct B sweep timing at 1 ms/DIV.
- 57. Check B Sweep Length. Page 6-51
11.0 division, ± 0.5 division.
- 58. Check A Sweep Length. Page 6-51
Variable from four divisions, or less, to 11.0 divisions, ± 0.5 division.
- 59. Check B Ends A Operation. Page 6-51
A sweep ends immediately after the end of B sweep when the A SWEEP LENGTH control is set to B ENDS A.
- 60. Check A Variable Control Range. Page 6-51
Continuously variable sweep rates between the calibrated A TIME/DIV switch settings.
- 61. Check B Variable Control Range. Page 6-52
Continuously variable sweep rates between the calibrated B TIME/DIV switch settings.
- 62. Adjust A and B One Microsecond Timing (C740A, C940A). Page 6-52
Correct A and B sweep timing at 1 μs /DIV.
- 63. Adjust A and B 0.5 Microsecond Timing (C740A, C940A). Page 6-53
Correct A and B sweep timing at 0.5 μs /DIV.
- 64. Adjust High-Speed Linearity (C1081, C1091). Page 6-53
Optimum linearity over the center eight divisions.
- 65. Check A Sweep Timing Accuracy. Page 6-53
Within 3% over middle eight divisions of the display. Within 5% over any two-division interval within center eight divisions.
- 66. Check A Magnified Sweep Accuracy. Page 6-54
Within 4% over middle eight divisions of the CRT display with the MAG switch set to $\times 10$. Within 5% over any two-division interval within center eight divisions. Magnifier light must be on.
- 67. Check B Sweep Timing Accuracy. Page 6-54
Within 3% over middle eight divisions of display. Within 5% over any two-division interval within center eight divisions.
- 68. Check B Magnified Sweep Accuracy. Page 6-54
Within 4% over middle eight divisions of the CRT display with the MAG switch set to $\times 10$. Within 5% over any two-division interval within center eight divisions.
- 69. Check Delay-Time Accuracy. Page 6-54
DELAY TIME switch (A TIME/DIV) settings of 1 μs to 50 ms, within 1.5%; .1 s to 5 s, within 2.5%.
- 70. Check Delay-Time Multiplier Incremental Linearity. Page 6-55
Within 0.2%.
- 71. Check Delay-Time Jitter. Page 6-55
One part, or less, in 20,000.
- 72. Adjust X Gain (R567). Page 6-57
Correct horizontal deflection for X-Y mode operation in the 20 mV CH 1 VOLTS/DIV switch position.
- 73. Adjust X-Y Phasing (L568, R569). Page 6-58
 $\pm 3^\circ$ or less phase shift up to two megahertz.
- 74. Check X Bandwidth in X-Y Mode. Page 6-59
Not more than -3 dB at two megahertz.
- 75. Check Beam Finder Operation. Page 6-59
Display remains within graticule area when BW-BEAM FINDER switch is in the BEAM FINDER position regardless of the deflection factor or POSITION control settings.
- 76. Check Chopped Operation. Page 6-59
Chopped repetition rate, one megahertz $\pm 20\%$; time segment displayed from each channel, 416 to 625 nanoseconds; switching transients blanked out.
- 77. Adjust Calibrator Repetition Rate (T1275). Page 6-60
One kilohertz, $\pm 0.5\%$.
- 78. Check Calibrator Duty Cycle. Page 6-61
49% to 51%.
- 79. Check Calibrator Risetime. Page 6-61
One microsecond or less.
- 80. Check Current Through Current Probe Cal Loop. Page 6-61
Five milliamperes.
- 81. Adjust Z Axis Compensation (C1352). Page 6-63
Optimum square corner on blanking pulse.
- 82. Check External Z Axis Operation. Page 6-64
Noticeable trace modulation with five-volt signal from DC to 50 megahertz.
- 83. Check A + Gate Output Signal. Page 6-64
Polarity, positive going; amplitude, 12.6 volts $\pm 10\%$; duration, about 11 times the A TIME/DIV switch setting.

Calibration—Type 454/R454

- 84. Check A Sweep Output Signal. Page 6-65
Polarity, positive going; amplitude, 10 volts $\pm 10\%$; duration, about 11 times the A TIME/DIV switch setting.
- 85. Check B + Gate Output Signal. Page 6-65
Polarity, positive going; amplitude, 12.6 volts $\pm 10\%$; duration, about 11 times the B TIME/DIV switch setting.

CALIBRATION PROCEDURE

General

The following procedure is arranged in a sequence which allows the Type 454 to be calibrated with the least interaction of adjustments and reconnection of equipment. However, some adjustments affect the calibration of other circuits within the instrument. In this case, it will be necessary to check the operation of other parts of the instrument. When a step interacts with others, the steps which need to be checked are noted in the "INTERACTION-..." step.

Any needed maintenance should be performed before proceeding with calibration. Troubles which become apparent during calibration should be corrected using the techniques given in the Maintenance section.

The steps titled "Adjust . . . ①" in the following procedure provide a check of instrument performance, whenever possible, before the adjustment is made. The symbol ① is used to identify the steps in which an adjustment is made. **To prevent recalibration of other circuits when performing a partial calibration, readjust only if the listed tolerance is not met.** However, when performing a complete calibration, best overall performance will be provided if each adjustment is made to the exact setting, even if the "CHECK- . . ." is within the allowable tolerance.

In the following procedure, a test equipment setup picture is shown for each major group of adjustments and checks. Beneath each setup picture is a complete list of front panel control settings for the Type 454. To aid in locating individual controls which have been changed during complete calibration, these control names are printed in bold type. If only a partial calibration is performed, start with the nearest setup preceding the desired portion. Type 454 front-panel control titles referred to in this procedure are capitalized (e.g., HORIZ DISPLAY). Internal adjustment titles are initial capitalized only (e.g., Normal Gain).

The following procedure uses the equipment listed under Equipment Required. If equipment is substituted, control settings or test equipment setup may need to be altered to meet the requirements of the equipment used.

NOTE

All waveforms shown in this procedure are actual waveform photographs taken with a Tektronix Oscilloscope Camera System. Graticule lines have been photographically retouched.

Preliminary Procedure

1. Remove the top and bottom covers from the Type 454.
2. Connect the autotransformer to a suitable power source.
3. Connect the Type 454 to the autotransformer output.
4. Set the autotransformer output voltage to the center voltage of the range selected by the Line Voltage Selector assembly on the rear panel.
5. Set the Type 454 POWER switch to ON (set INTENSITY control fully counterclockwise). Allow at least 20 minutes warm up at 25° C, $\pm 5^\circ$ C for checking the instrument to the given accuracy.

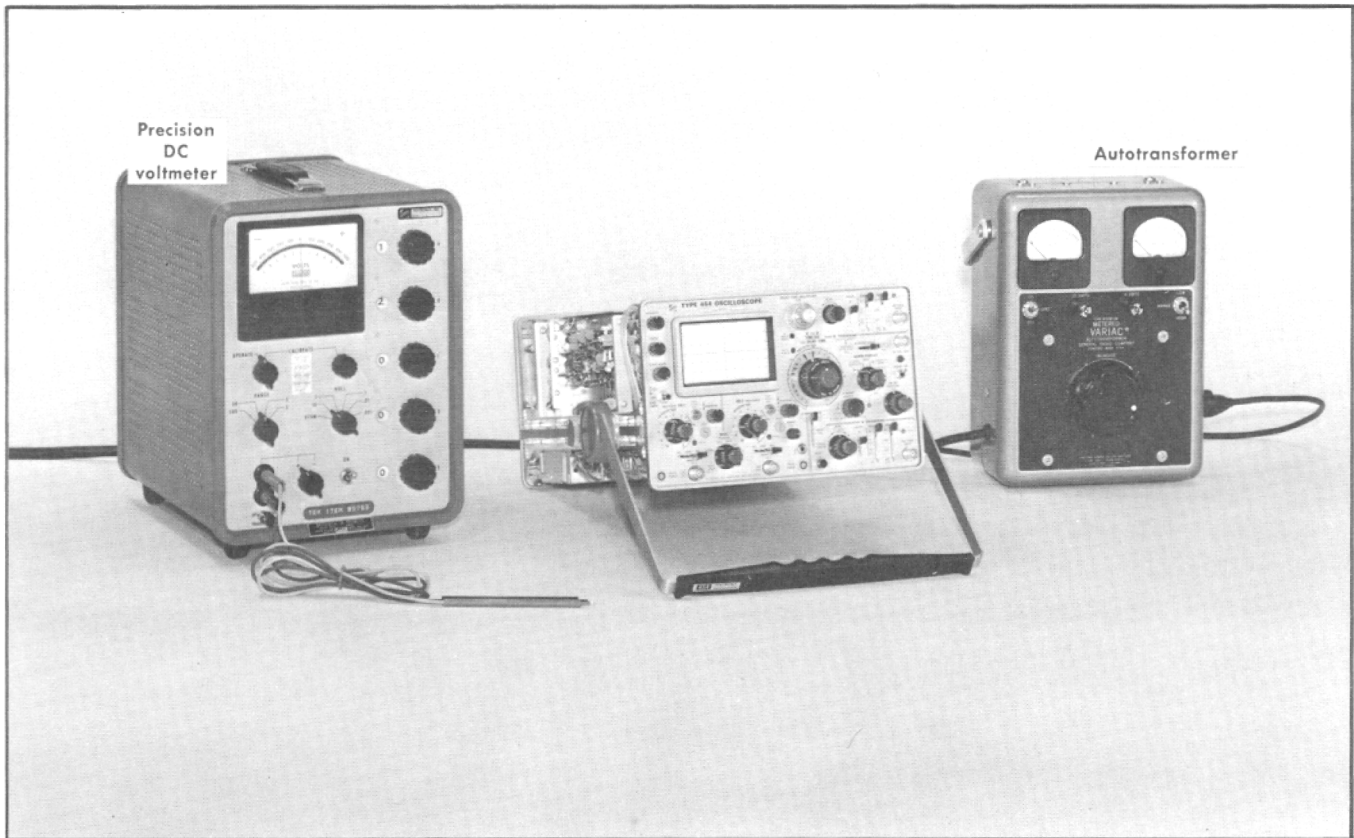

Fig. 6-3. Initial test equipment setup for steps 1 through 6.

| | |
|--|------------------|
| CRT controls | |
| INTENSITY | Counterclockwise |
| FOCUS | Midrange |
| SCALE ILLUM | As desired |
| BW-BEAM FINDER | FULL |
| Vertical controls (both channels if applicable) | |
| VOLTS/DIV | 20 mV |
| VARIABLE | CAL |
| POSITION | Midrange |
| Input Coupling | DC |
| MODE | CH 1 |
| TRIGGER | NORM |
| INVERT | Pushed in |
| Triggering controls (both A and B if applicable) | |
| LEVEL | Fully clockwise |
| SLOPE | + |
| COUPLING | AC |
| SOURCE | INT |
| Sweep controls | |
| DELAY-TIME MULTIPLIER | 0.10 |
| A TIME/DIV | 1 ms |
| B TIME/DIV | 1 ms |
| A VARIABLE | CAL |

| | |
|---------------------|------------------------------|
| A SWEEP MODE | NORM TRIG |
| B SWEEP MODE | TRIGGERABLE AFTER DELAY TIME |
| HORIZ DISPLAY | A |
| MAG | OFF |
| A SWEEP LENGTH | FULL |
| POSITION | Midrange |
| POWER | ON |
| Side-panel controls | |
| B TIME/DIV VARIABLE | CAL |

1. Adjust —12-Volt Power Supply ❶

- a. Test equipment setup is shown in Fig. 6-3.
- b. Connect the precision DC voltmeter from the —12-volt test point (pin connector 'D', Low-Voltage Regulator board; see Fig. 6-4) to chassis ground.
- c. CHECK—Meter reading; —12 volts, ± 0.032 volt.
- d. ADJUST— —12 Volts adjustment, R1124 (see Fig. 6-4), for —12 volts.
- e. INTERACTION—May affect operation of all circuits within the Type 454.

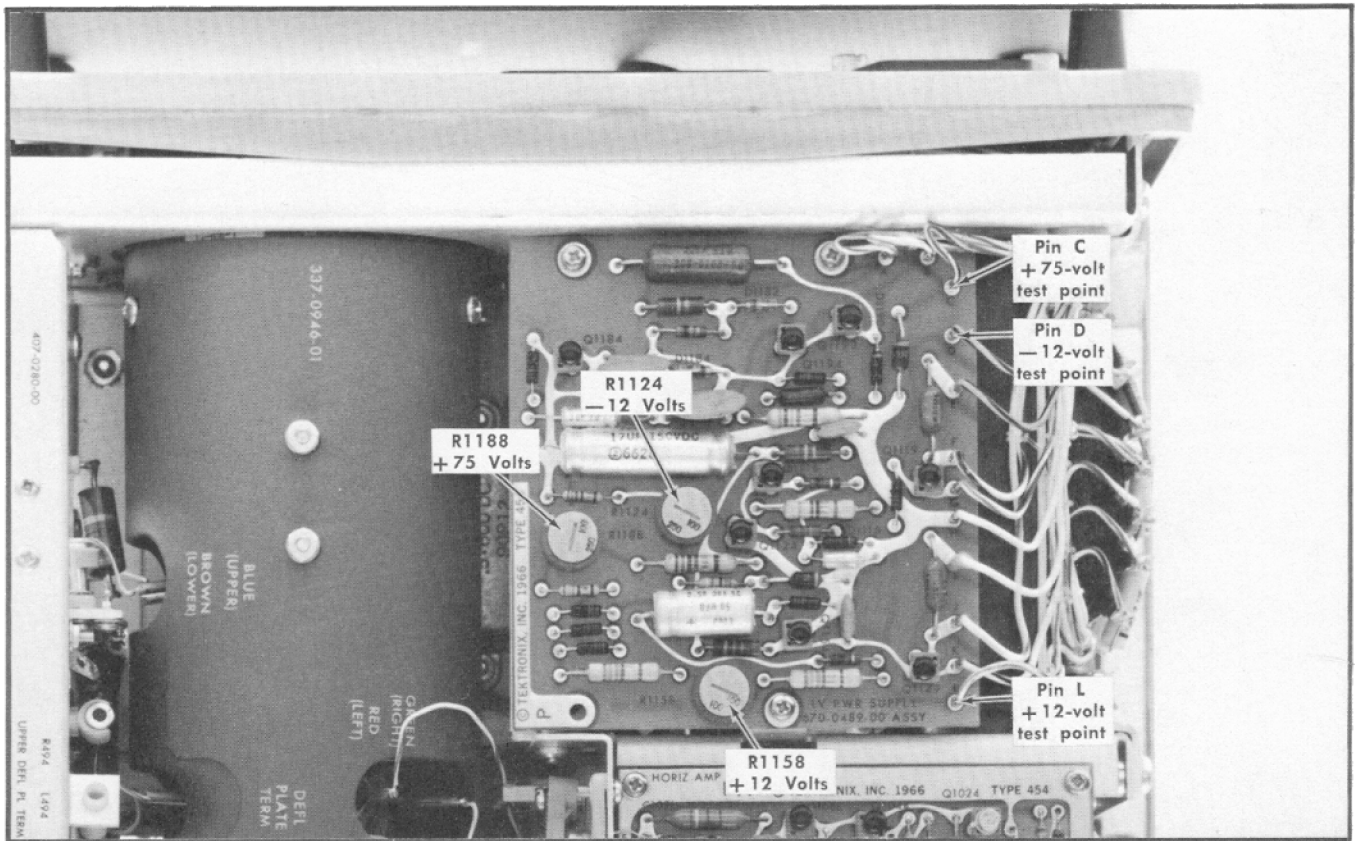

Fig. 6-4. Low-voltage power supply test points and adjustments (Low-Voltage Regulator circuit board).

2. Adjust +12-Volt Power Supply ①

- a. Connect the precision DC voltmeter from the center contact of the 1 V CAL 1 kHz connector to chassis ground.
- b. Remove Q1275 (behind swing-out side panel; see Fig. 6-5) from the Calibrator board.
- c. CHECK—Meter reading; +1 volt, ± 0.003 volt.
- d. ADJUST—+12 Volts adjustment, R1158 (see Fig. 6-4), for +1 volt.
- e. Replace Q1275.
- f. Connect the precision DC voltmeter from the +12-volt test point (pin connector 'L', Low-Voltage Regulator board; see Fig. 6-4) to chassis ground.
- g. CHECK—Meter reading; +12.0 to +12.2 volts.
- h. INTERACTION—May affect operation of all circuits within the Type 454.

3. Adjust +75-Volt Power Supply ①

- a. Connect the precision DC voltmeter from the +75-volt test point (pin connector 'C', Low-Voltage Regulator board; see Fig. 6-4) to chassis ground.

- b. CHECK—Meter reading; +75 volts, ± 0.278 volt.
- c. ADJUST—+75 Volts adjustment, R1188 (see Fig. 6-4), for +75 volts.
- d. INTERACTION—May affect operation of all circuits within the Type 454.

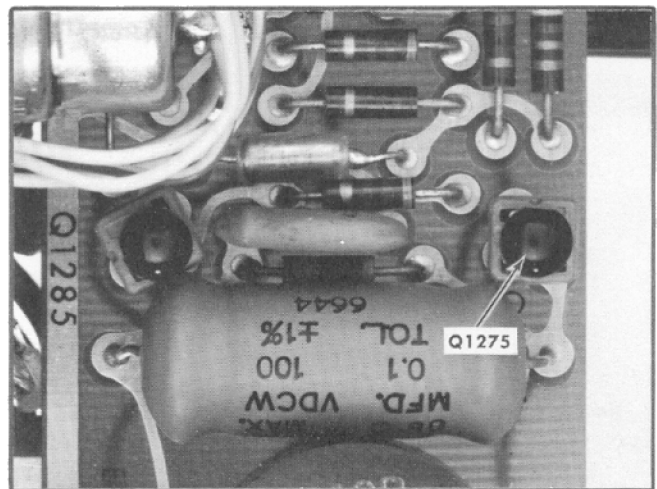

Fig. 6-5. Location of Q1275 (Calibrator circuit board).

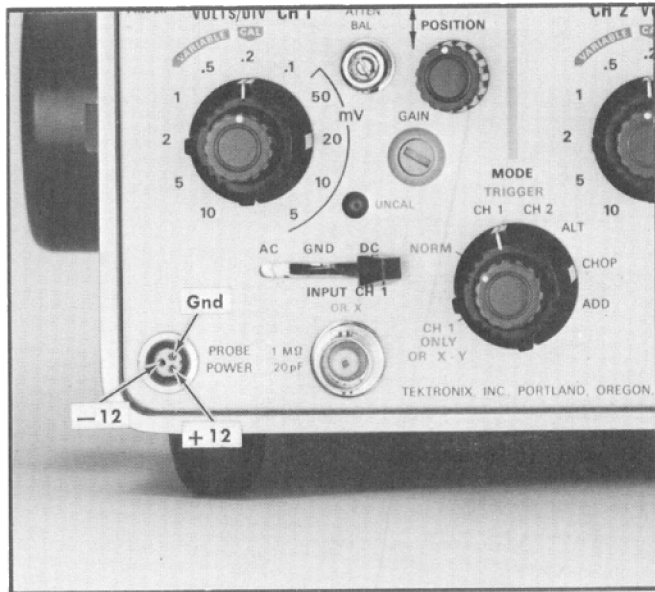

Fig. 6-6. Location of pins in the CH 1 and 2 PROBE POWER connectors.

4. Check Voltage at PROBE POWER Connectors

- a. Connect the precision DC voltmeter between the +12-volt terminal of the CH 1 PROBE POWER connector (see Fig. 6-6) and the ground terminal.
- b. CHECK—Meter reading +12 volts.
- c. Connect the precision DC voltmeter between the -12-volt terminal of the CH 1 PROBE POWER connector (see Fig. 6-6) and the ground terminal.
- d. CHECK—Meter reading -12 volts.
- e. Connect the precision DC voltmeter between the ground terminal of the CH 1 PROBE POWER connector (see Fig. 6-6) and chassis ground.
- f. CHECK—Meter reading zero volts.
- g. Connect the precision DC voltmeter between the +12-volt terminal of the CH 2 PROBE POWER connector (see Fig. 6-6) and the ground terminal.
- h. CHECK—Meter reading +12 volts.
- i. Connect the precision DC voltmeter between the -12-volt terminal of the CH 2 PROBE POWER connector (see Fig. 6-6) and the ground terminal.
- j. CHECK—Meter reading -12 volts.
- k. Connect the precision DC voltmeter between the ground terminal of the CH 2 PROBE POWER connector (see Fig. 6-6) and chassis ground.
- l. CHECK—Meter reading zero volts.

5. Adjust High-Voltage Supply and Check Regulation

- a. Connect the precision DC voltmeter (use the precision 2 kV divider) from the -1960 V test point (see Fig. 6-7) to chassis ground.
- b. CHECK—Meter reading; -1960 volts, ± 19.6 volts.
- c. ADJUST—High-Voltage adjustment, R1401 (see Fig. 6-7), for -1960 volts.
- d. INTERACTION—May affect operation of all circuits within the Type 454.
- e. CHECK—Change the autotransformer output voltage throughout the regulating range selected by the Line Voltage Selector assembly on the rear panel and check for less than ± 58.8 volts change in the high-voltage output level. Also vary the INTENSITY control throughout its range at the maximum and minimum line voltage; check that regulation remains within given limits.

NOTE

- If the high-voltage supply is out of regulation, check the regulation of the low-voltage supplies (step 7) before troubleshooting in the high-voltage supply.
- f. Return the autotransformer output voltage to the center of the regulating range selected by the Line Voltage Selector assembly.

6. Adjust CRT Grid Bias

- a. Connect the precision DC voltmeter from TP1349 (Z Axis Amplifier board; see Fig. 6-7) to chassis ground.
- b. Set the A SWEEP MODE switch to SINGLE SWEEP.
- c. Set the INTENSITY control for a meter reading of +12 volts.
- d. ADJUST—CRT Grid Bias adjustment, R1447 (see Fig. 6-7), so the spot on the CRT just disappears (it may be necessary to turn the horizontal POSITION control clockwise to bring the spot onto the viewing area).

CAUTION

Do not allow the bright spot to remain stationary for an extended period as it may burn the CRT phosphor.

- e. INTERACTION—Check steps 75, 81 and 82.
- f. Disconnect the precision DC voltmeter.

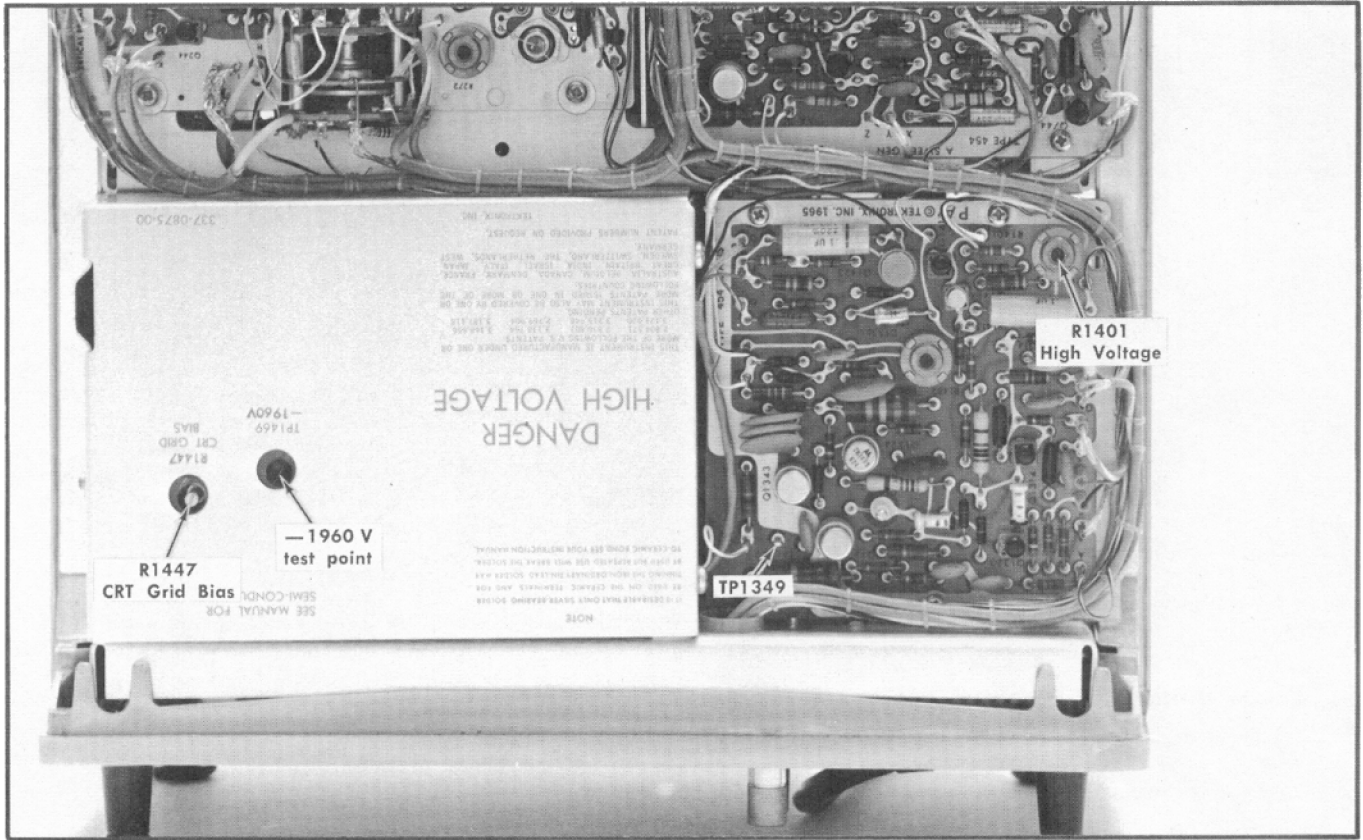

Fig. 6-7. Location of high-voltage adjustments and test points.

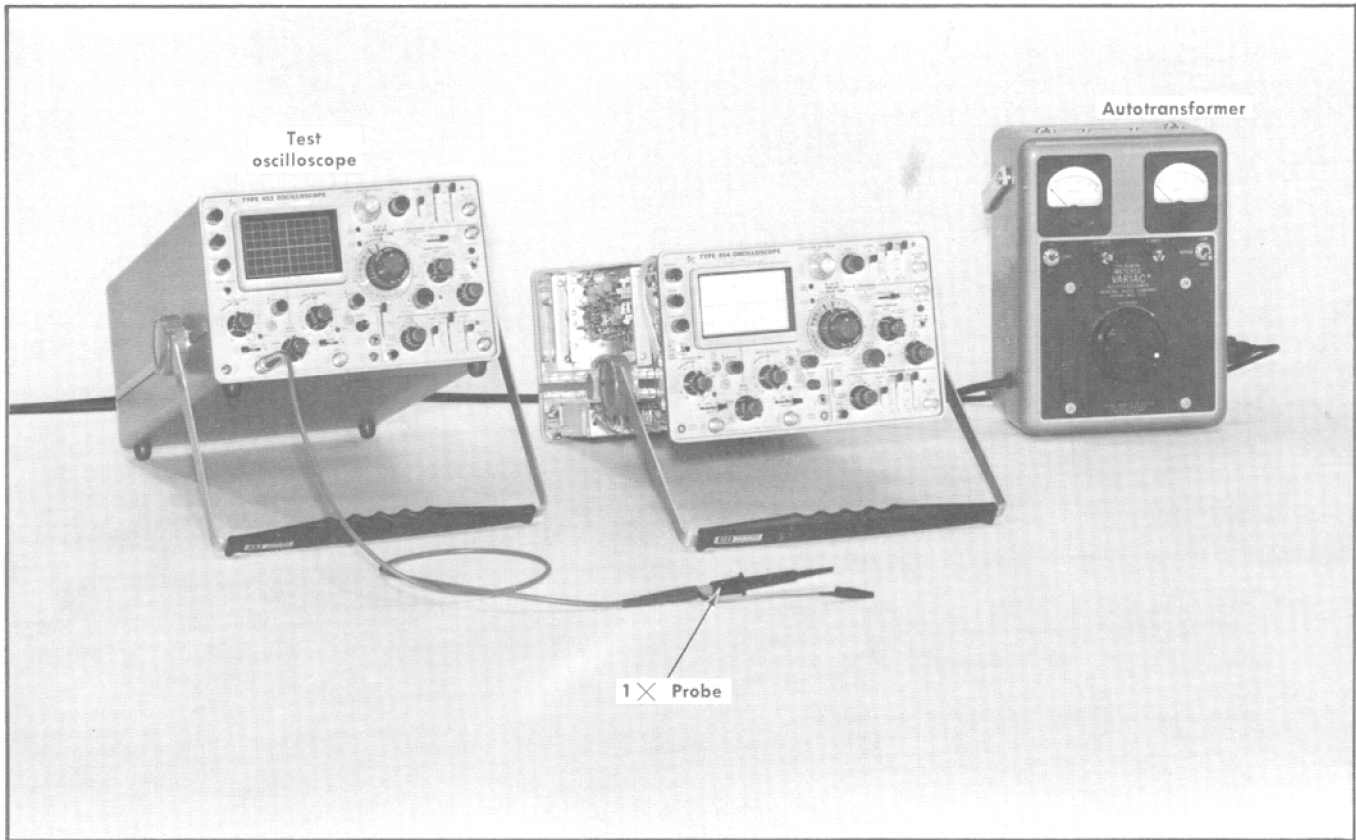

Fig. 6-8. Initial test equipment setup for steps 7 and 8.

CRT controls

| | |
|------------------|-------------------------|
| INTENSITY | Counterclockwise |
| FOCUS | Midrange |
| SCALE ILLUM | As desired |
| BW-BEAM FINDER | FULL |

Vertical controls (both channels if applicable)

| | |
|----------------|-----------|
| VOLTS/DIV | 20 mV |
| VARIABLE | CAL |
| POSITION | Midrange |
| Input Coupling | DC |
| MODE | CH 1 |
| TRIGGER | NORM |
| INVERT | Pushed in |

Triggering controls (both A and B if applicable)

| | |
|----------|-----------------|
| LEVEL | Fully clockwise |
| SLOPE | + |
| COUPLING | AC |
| SOURCE | INT |

Sweep controls

| | |
|-----------------------|------|
| DELAY-TIME MULTIPLIER | 0.10 |
| A TIME/DIV | 1 ms |
| B TIME/DIV | 1 ms |
| A VARIABLE | CAL |

A SWEEP MODE

B SWEEP MODE

HORIZ DISPLAY

MAG

A SWEEP LENGTH

POSITION

POWER

Side-panel controls

B TIME/DIV VARIABLE

NORM TRIG

TRIGGERABLE AFTER
DELAY TIME

A

OFF

FULL

Midrange

ON

CAL

7. Check Low-Voltage Power-Supply Ripple

NOTE

This step also checks regulation of the low-voltage supplies.

a. Test equipment setup is shown in Fig. 6-8.

b. Connect the 1X probe to the test oscilloscope input.

c. Set the test oscilloscope for a vertical deflection of 0.005 volts/division, AC coupled, at a sweep rate of five milliseconds/division. Use line-frequency triggering to provide a stable display.

Calibration—Type 454/R454

d. CHECK—Two millivolts (0.4 division) peak-to-peak maximum line-frequency ripple on the -12 -volt, $+12$ -volt and $+75$ -volt supplies while changing the autotransformer output voltage throughout the regulating range selected by the Line Voltage Selector assembly on the rear panel. Power-supply test points are shown in Fig. 6-4. Fig. 6-9 shows a typical test oscilloscope display of ripple.

e. Return autotransformer output voltage to the center of the regulating range selected by the Line Voltage Selector assembly. (If the line voltage is near the center of the regulating range, the Type 454 may be connected directly to the line; otherwise, leave the instrument connected to the autotransformer for the remainder of this procedure.)

f. Disconnect all test equipment.

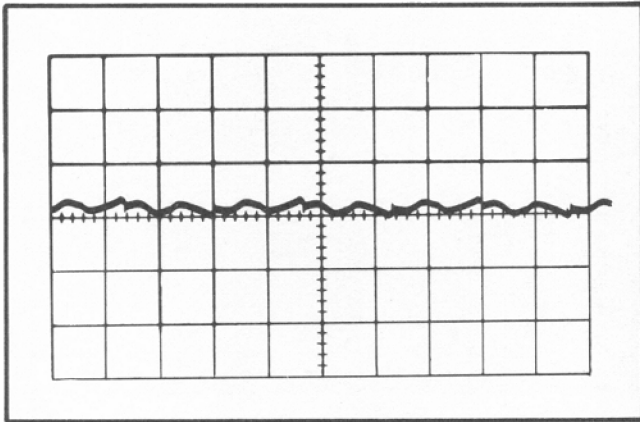

Fig. 6-9. Typical test oscilloscope display of power-supply ripple (60-cycle line). Vertical deflection 0.005 volts/division; sweep rate, five milliseconds/division.

8. Adjust Trace Alignment

a. Set the A SWEEP MODE switch to AUTO TRIG.

b. Advance the INTENSITY control until the trace is visible.

c. Turn the CH 1 POSITION control to move the trace to the center horizontal line.

d. Set the FOCUS control for as sharp a display as possible.

e. CHECK—The trace should be parallel with the center horizontal line.

f. ADJUST—TRACE ROTATION adjustment, R1480 (see Fig. 6-10), so the trace is parallel to the horizontal graticule lines.

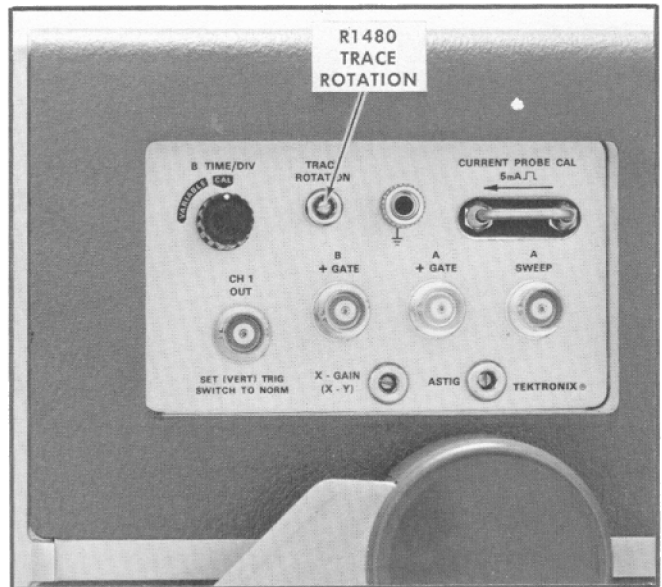

Fig. 6-10. Location of TRACE ROTATION adjustment (side panel).

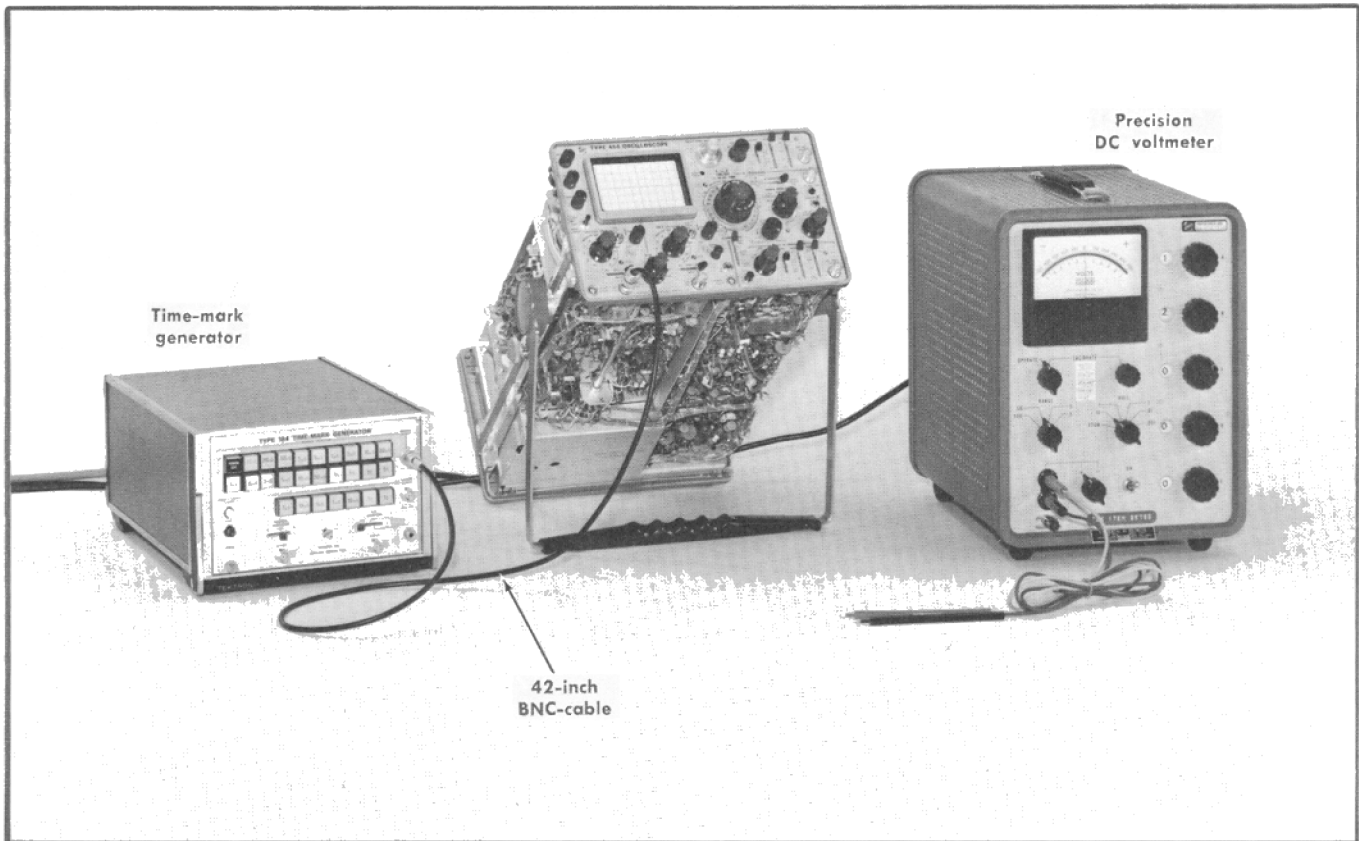

Fig. 6-11. Initial test equipment setup for steps 9 through 14.

CRT controls

INTENSITY
FOCUS

SCALE ILLUM
BW-BEAM FINDER

Midrange
Adjust for focused display

As desired
FULL

A SWEEP MODE
B SWEEP MODE

HORIZ DISPLAY
MAG
A SWEEP LENGTH
POSITION
POWER

AUTO TRIG
TRIGGERABLE AFTER
DELAY TIME

A
OFF
FULL
Midrange
ON

Vertical controls (both channels if applicable)

VOLTS/DIV 20 mV
VARIABLE CAL
POSITION Midrange
Input Coupling DC
MODE CH 1
TRIGGER NORM
INVERT Pushed in

Side-panel controls

B TIME/DIV VARIABLE CAL

Triggering controls (both A and B if applicable)

LEVEL 0
SLOPE +
COUPLING AC
SOURCE INT

9. Adjust Astigmatism



- a. Test equipment setup is shown in Fig. 6-11.
- b. Connect the time-mark generator (Type 184) to the INPUT CH 1 connector with the 42-inch BNC cable.
- c. Set the time-mark generator for 1- and 0.1-millisecond markers.
- d. Set the CH 1 VOLTS/DIV switch so the large markers extend beyond the bottom and the top of the graticule area.
- e. Set the A LEVEL control for a stable display.
- f. CHECK—Markers should be well defined with optimum setting of FOCUS control.
- g. ADJUST—FOCUS control and ASTIG adjustment, R1489 (see Fig. 6-12), for best definition of the markers.

Sweep controls

DELAY-TIME MULTIPLIER 0.10
A TIME/DIV 1 ms
B TIME/DIV 1 ms
A VARIABLE CAL



Fig. 6-12. Location of ASTIG adjustment (side panel).

10. Adjust Y Axis Alignment

- a. CHECK—The markers should be parallel to the center vertical line (see Fig. 6-13A).
- b. ADJUST—Y Axis Align adjustment, R1485 (see Fig. 6-13B), to align the markers with the center vertical line.

11. Adjust CRT Geometry

- a. Set the horizontal POSITION and the A VARIABLE controls so a large marker coincides with each vertical graticule line.
- b. CHECK—Geometry at left and right edges of the graticule. Fig. 6-14 shows a typical display of good geometry as well as examples of poor geometry.
- c. ADJUST—Geometry adjustment, R1482 (see Fig. 6-14D), for minimum bowing of the trace at the left and right edges of the graticule.
- d. INTERACTION—Recheck step 10.
- e. Disconnect the time-mark generator.
- f. Position the trace to the top of the graticule area.
- g. CHECK—Deviation from straight line should not exceed 0.1 division.
- h. Position the trace to the bottom of the graticule area.
- i. CHECK—Deviation from straight line should not exceed 0.1 division.

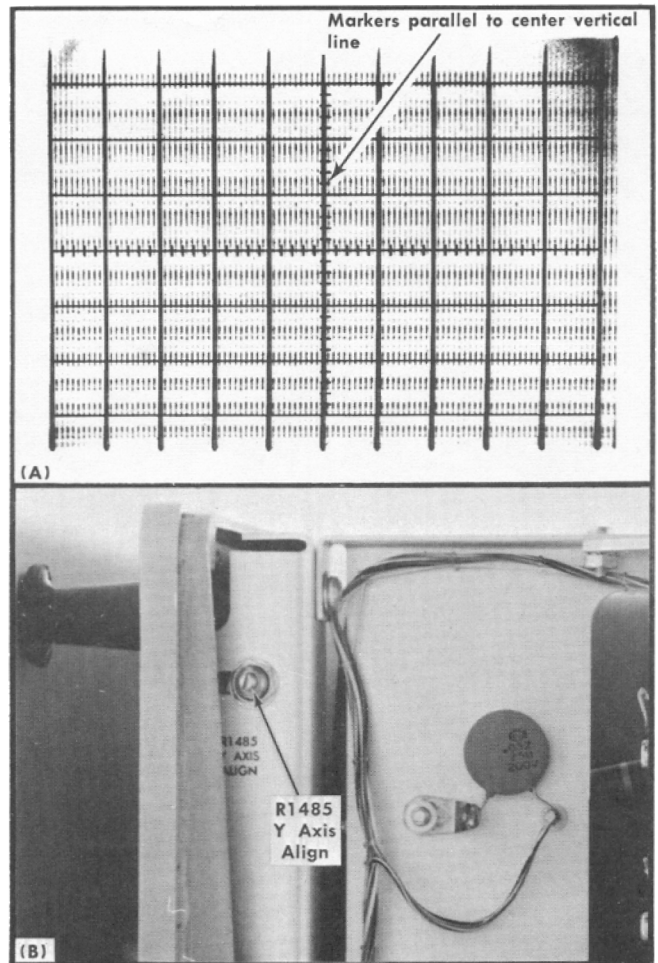

Fig. 6-13. (A) Typical CRT display showing correct Y-axis alignment, (B) location of Y Axis Alignment adjustment (left side).

12. Adjust Channel 1 and 2 Step Attenuator Balance

- a. Position the trace to the center horizontal line with the CH 1 POSITION control.
- b. Change the following control settings:

| | |
|-----------------------------|-------|
| VOLTS/DIV (CH 1 and 2) | 20 mV |
| Input Coupling (CH 1 and 2) | GND |
- c. CHECK—Change the CH 1 VOLTS/DIV switch from 20 mV to 5 mV. Trace should not move more than 0.1 division vertically.
- d. ADJUST—CH 1 STEP ATTEN BAL adjustment, R21 (see Fig. 6-15A), for 0.1 division or less trace shift as the CH 1 VOLTS/DIV switch is changed from 20 mV to 5 mV.

NOTE

- Use the BW-BEAM FINDER switch to locate the trace if it is deflected off screen when switching to 10 or 5 mV.
- e. Set the MODE switch to CH 2.

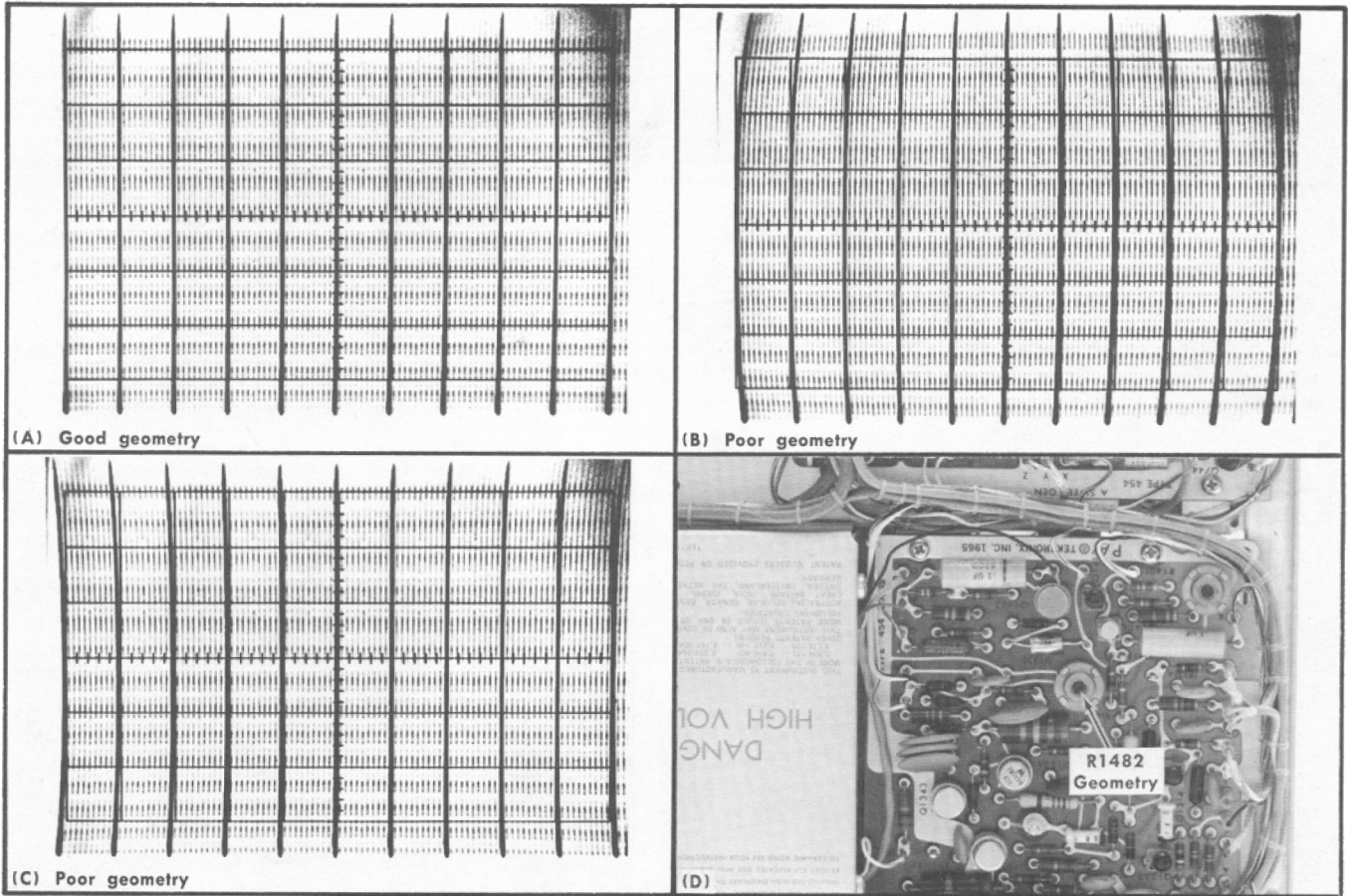

Fig. 6-14. (A) Typical CRT display showing good geometry, (B) and (C) poor geometry, (D) location of Geometry adjustment (Z Axis Amplifier circuit board).

- f. Position the trace to the center horizontal line with the CH 2 POSITION control.
- g. CHECK—Change the CH 2 VOLTS/DIV switch from 20 mV to 5 mV. Trace should not move more than 0.1 division vertically.
- h. ADJUST—CH 2 STEP ATTEN BAL adjustment, R121 (see Fig. 6-15A), for 0.1 division or less trace shift as the CH 2 VOLTS/DIV switch is changed from 20 mV to 5 mV.
- i. CHECK—Change the CH 2 VOLTS/DIV switch from 50 mV to .1. Trace should not move more than 0.1 division vertically.
- j. ADJUST—CH 2 100 mV Step Atten Bal adjustment, R128 (see Fig. 6-15B), for 0.1 division or less shift as the CH 2 VOLTS/DIV switch is changed from 50 mV to .1.
- k. Set the MODE switch to CH 1.
- l. CHECK—Change the CH 1 VOLTS/DIV switch from 50 mV to .1. Trace should not move more than 0.1 division vertically.
- m. ADJUST—CH 1 100 mV Step Atten Bal adjustment, R28 (see Fig. 6-15B), for 0.1 division or less trace shift as the CH 1 VOLTS/DIV switch is changed from 50 mV to .1.

- n. Repeat parts a through m for optimum step attenuator balance.

13. Adjust Vertical Centering ❶

- a. Set the MODE switch to CHOP.
- b. Move the traces to the center horizontal line with the CH 1 and CH 2 POSITION controls.
- c. Set the MODE switch to ADD.
- d. CHECK—Trace should be at the center horizontal line of the graticule. Note the amount that the trace is deflected away from the center horizontal line.
- e. ADJUST—Vertical Centering adjustment, R334 (see Fig. 6-16A), to move the trace twice the distance observed in part d away from the center horizontal line.
- f. Repeat parts a through e until the trace remains at the center horizontal line when the MODE switch is changed from CHOP to ADD.
- g. Connect the six-inch jumper lead across the delay-line input on the Vertical Preamp circuit board (see Fig. 6-16A).

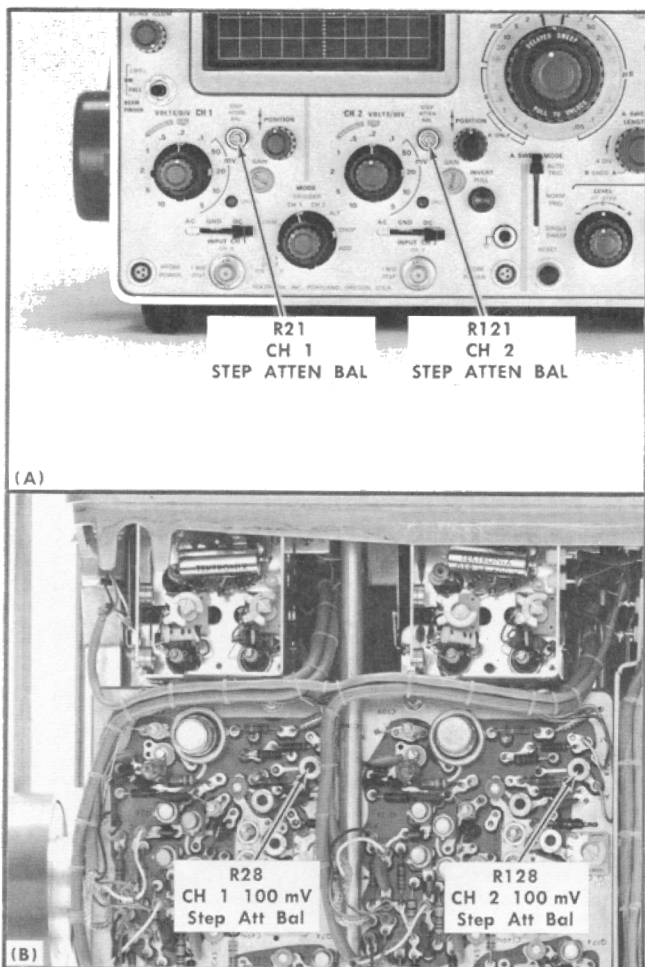

Fig. 6-15. (A) Location of Channel 1 and 2 STEP ATT BAL adjustments (front panel), (B) location of Channel 1 and 2 100 mV Step Att Bal adjustment (Vertical Preamp circuit board).

- h. CHECK—Trace within one division of the center horizontal line.
- i. Disconnect the jumper lead.

14. Adjust Channel 1 and 2 Position Centering

- a. Connect the precision DC voltmeter between pin connector 'Y' on the Vertical Preamp circuit board (see Fig. 6-17) and ground.
- b. Set the CH 1 POSITION control for a meter reading of -6.2 volts. (The dot on the CH 1 POSITION control should be centered mechanically. If not, loosen the set screw and reposition the knob.)
- c. Set the MODE switch to CH 1.
- d. CHECK—Trace at the center horizontal line.
- e. ADJUST—CH 1 Position Center adjustment, R40 (see Fig. 6-17), to position the trace to the center horizontal line.

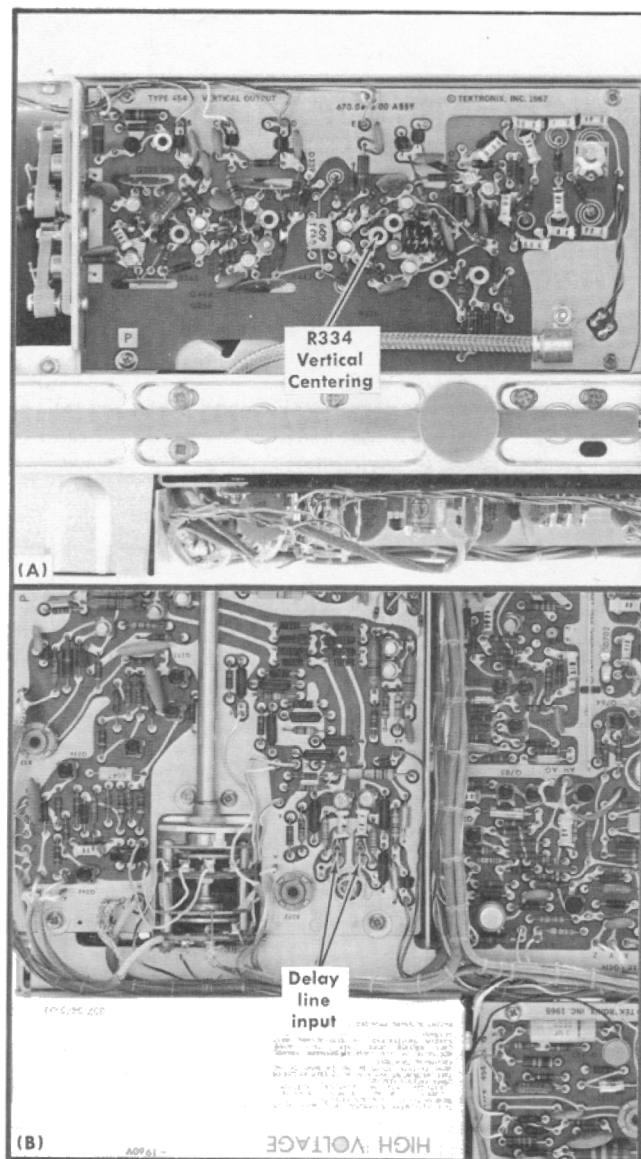

Fig. 6-16. (A) Location of Vertical Centering adjustment (Vertical Output Amplifier circuit board), (B) location of delay line input (Vertical Preamp circuit board).

- f. Set the MODE switch to CH 2.
- g. Connect the precision DC voltmeter between pin connector 'AJ' on the Vertical Preamp circuit board and ground (see Fig. 6-17).
- h. Set the CH 2 POSITION control for a meter reading of -6.2 volts. (The dot on the CH 2 POSITION control should be centered mechanically. If not, loosen the set screw and reposition the knob.)
- i. CHECK—Trace at the center horizontal line.
- j. ADJUST—CH 2 Position Center adjustment, R140 (see Fig. 6-17), to position the trace to the center horizontal line.
- k. Disconnect all test equipment.

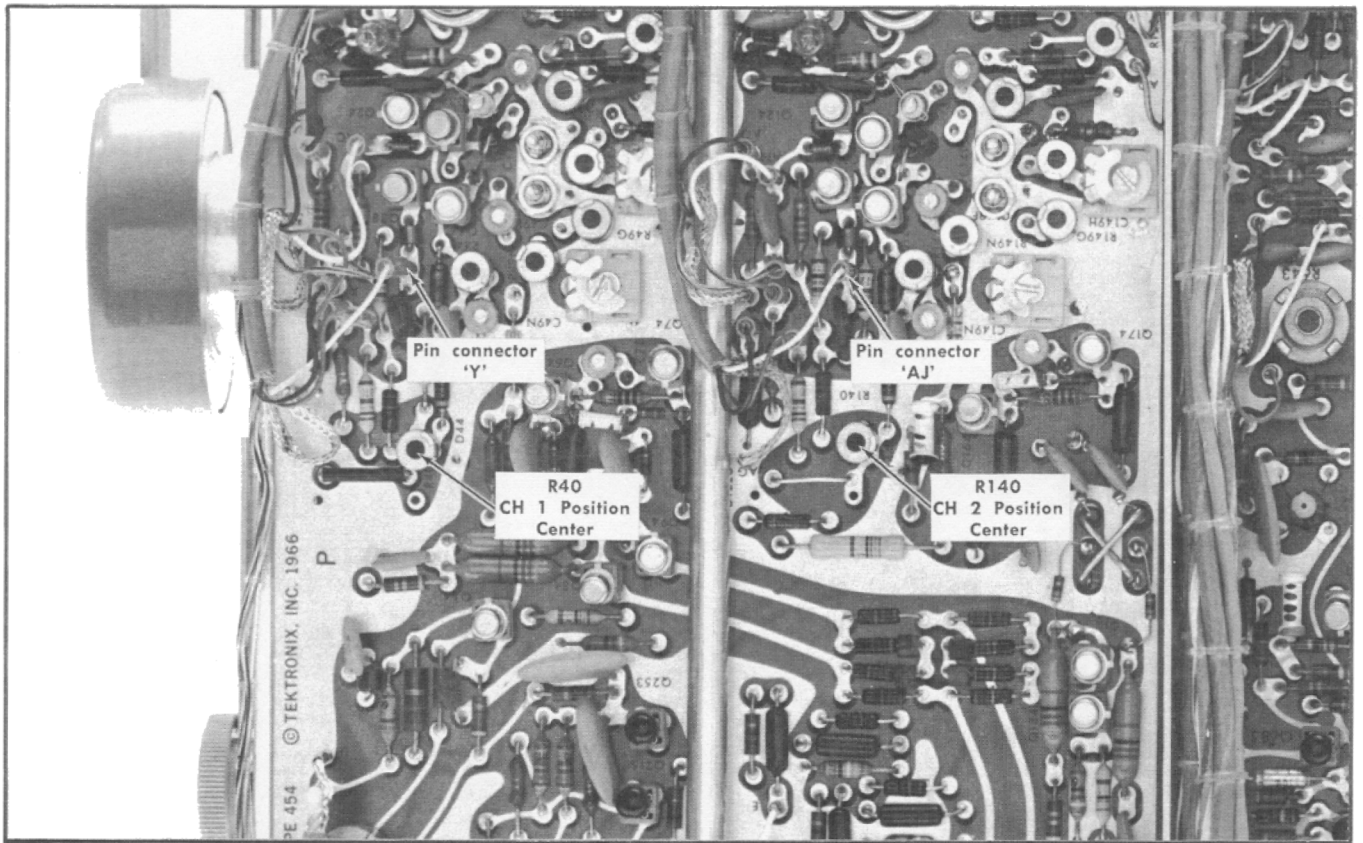

Fig. 6-17. Location of Channel 1 and 2 Position Center adjustments and test points (Vertical Preamp circuit board).

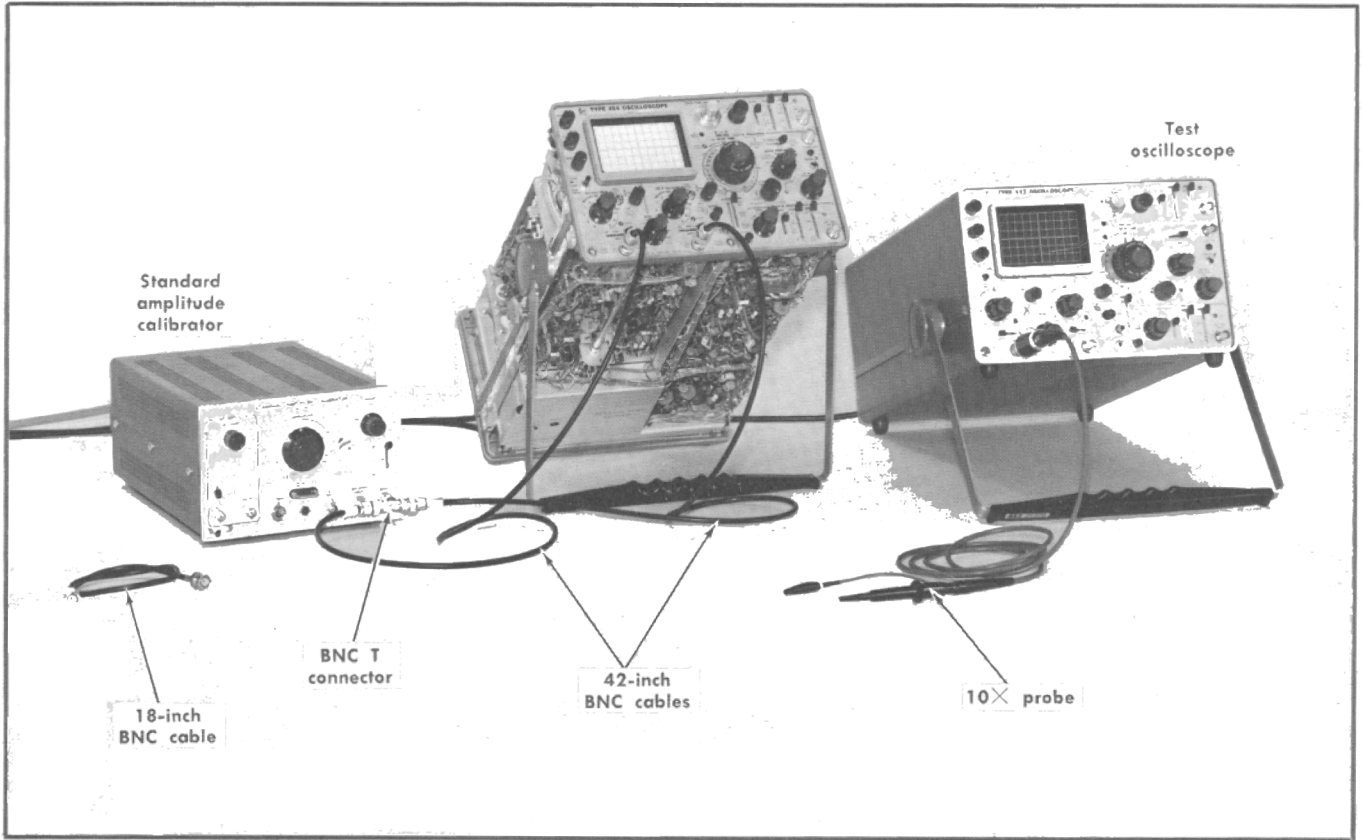

Fig. 6-18. Initial test equipment setup for steps 15 through 23.

CRT controls

INTENSITY Midrange
 FOCUS Adjust for focused display
 SCALE ILLUM As desired
 BW-BEAM FINDER FULL

Vertical controls (both channels if applicable)

VOLTS/DIV 20 mV
 VARIABLE CAL
 POSITION Midrange
Input Coupling DC
MODE CH 1
 TRIGGER NORM
 INVERT Pushed in

Triggering controls (both A and B if applicable)

LEVEL 0
 SLOPE +
 COUPLING AC
 SOURCE INT

Sweep controls

DELAY-TIME MULTIPLIER 0.10
A TIME/DIV .5 ms
B TIME/DIV .5 ms
 A VARIABLE CAL

A SWEEP MODE
 B SWEEP MODE

HORIZ DISPLAY
 MAG
 A SWEEP LENGTH
 POSITION
 POWER

AUTO TRIG
 TRIGGERABLE AFTER
 DELAY TIME

A
 OFF
 FULL
 Midrange
 ON

Side-panel controls

B TIME/DIV VARIABLE CAL

15. Adjust Channel 1 and 2 and Output Amplifier Gain



- a. Test equipment setup is shown in Fig. 6-18.
- b. Connect the standard amplitude calibrator (067-0502-00) output connector to the INPUT CH 1 and INPUT CH 2 connectors through the BNC T connector and two BNC cables.
- c. Set the standard amplitude calibrator for a 0.1-volt square-wave output.
- d. Connect the 10X probe to the input of the test oscilloscope.

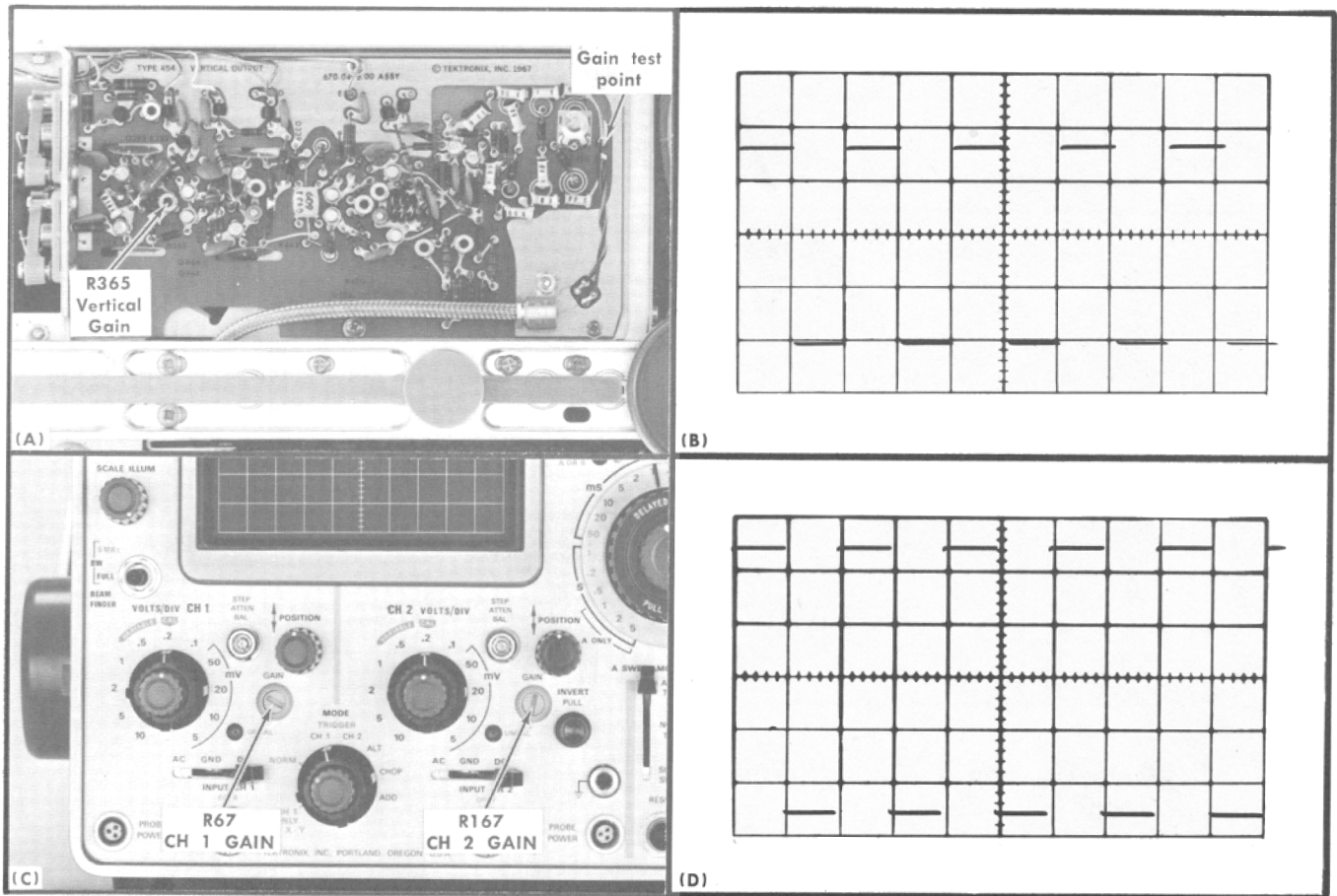

Fig. 6-19. (A) Delay-line output and Vertical Gain Adjustment (Vertical Output Amplifier circuit board), (B) typical test oscilloscope display showing correct Channel 1 gain adjustment, (C) location of Channel 1 and 2 GAIN adjustments (front panel), (D) typical CRT display showing correct vertical gain adjustment.

- e. Set the test oscilloscope for a vertical deflection factor of 10 millivolts/division, AC coupled, at a sweep rate of 0.5 millisecond/division.
- f. Connect the 10X probe tip to the gain test point (see Fig. 6-19A).
- g. CHECK—Test oscilloscope display for 3.75 divisions of deflection (see Fig. 6-19B).
- h. ADJUST—CH 1 GAIN adjustment, R67 (see Fig. 6-19C), for exactly 3.75 divisions of deflection on the test oscilloscope.
- i. Disconnect the 10X probe tip.
- j. CHECK—CRT display for five divisions of deflection (see Fig. 6-19D).
- k. ADJUST—Vertical Gain adjustment, R365 (see Fig. 6-19A), for exactly five divisions of deflection.

NOTE

If R365 does not have enough range to provide a five-division display, readjust R67 (part h of this step) to provide a five-division display (R365 must remain at maximum setting).

- l. Set the MODE switch to ADD.
- m. Pull the INVERT switch.

- n. CHECK—CRT display for straight line.
- o. ADJUST—CH 2 GAIN adjustment, R167 (see Fig. 6-19C), for straight line.

16. Check Added Mode Operation

- a. Push the INVERT switch in.
- b. Set the standard amplitude calibrator for a 50-millivolt square-wave output.
- c. CHECK—CRT display five divisions, ± 0.15 division, in amplitude (within 3%).

17. Check Channel 1 and 2 Deflection Accuracy

- a. Set the MODE switch to CH 1.
- b. Set the CH 2 Input Coupling switch to GND.
- c. CHECK—Using the CH 1 VOLTS/DIV switch and standard amplitude calibrator settings given in Table 6-1, check vertical deflection within 3% in each position of the CH 1 VOLTS/DIV switch.
- d. Set the MODE switch to CH 2.
- e. Set the CH 1 Input Coupling switch to GND and the CH 2 Input Coupling switch to DC.

Calibration—Type 454/R454

f. CHECK—Using the CH 2 VOLTS/DIV switch and standard amplitude calibrator settings given in Table 6-1, check vertical deflection within 3% in each position of the CH 2 VOLTS/DIV switch.

TABLE 6-1

Vertical Deflection Accuracy

| VOLTS/DIV Switch Setting | Standard Amplitude Calibrator Output | Vertical Deflection In Divisions | Maximum Error For $\pm 3\%$ Accuracy (divisions) |
|--------------------------|--------------------------------------|----------------------------------|--|
| 5 mV | 20 millivolts | 4 | ± 0.12 |
| 10 mV | 50 millivolts | 5 | ± 0.15 |
| 20 mV | 0.1 volt | 5 | Previously set in step 15 |
| 50 mV | 0.2 volt | 4 | ± 0.12 |
| .1 | 0.5 volt | 5 | ± 0.15 |
| .2 | 1 volt | 5 | ± 0.15 |
| .5 | 2 volts | 4 | ± 0.12 |
| 1 | 5 volts | 5 | ± 0.15 |
| 2 | 10 volts | 5 | ± 0.15 |
| 5 | 20 volts | 4 | ± 0.12 |
| 10 | 50 volts | 5 | ± 0.15 |

18. Check Channel 1 and 2 Variable Volts/Division Range

a. Set the standard amplitude calibrator for a 0.1-volt square-wave output.

b. Change the following control settings:

VOLTS/DIV (CH 1 and 2) 20 mV
 Input Coupling (CH 1 and 2) AC
 MODE CH 1

c. CHECK—Turn the CH 1 VARIABLE VOLTS/DIV control clockwise just past the CAL detent (minimum gain). Display should be reduced to two divisions or less (indicates adequate range for continuously variable deflection factors between the calibrated steps; see Fig. 6-20). CH 1 UNCAL light must be on when CH 1 VARIABLE control is not in CAL position.

d. Set the MODE switch to CH 2.

e. CHECK—Turn the CH 2 VARIABLE VOLTS/DIV control clockwise just past the CAL detent (minimum gain). Display should be reduced to two divisions or less (indicates adequate range for continuously variable deflection factors between calibrated steps; see Fig. 6-20). CH 2 UNCAL light must be on when CH 2 VARIABLE control is not in CAL position.

f. Disconnect the cable from the INPUT CH 2 connector.

19. Check Channel 1 and 2 Cascaded Deflection Factor

a. Connect the CH 1 OUT connector to the INPUT CH 2 connector with the 18-inch 50-ohm BNC cable.

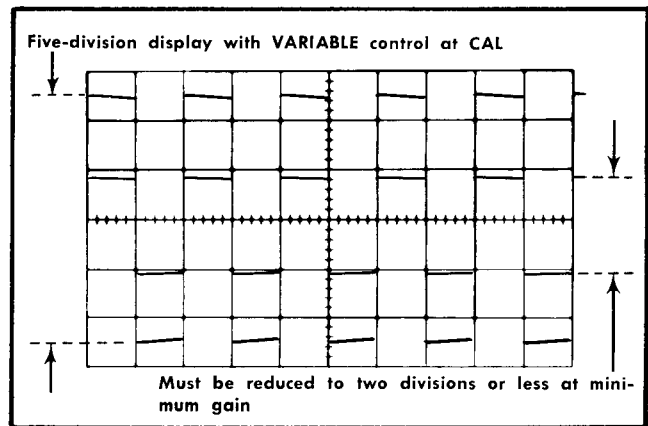

Fig. 6-20. Typical CRT display showing adequate Channel 1 and 2 VARIABLE control range (double exposure).

b. Change the following control settings:

VOLTS/DIV (CH 1 and 2) 5 mV
 VARIABLE (CH 1 and 2) CAL
 Input Coupling (CH 1 and 2) DC

c. Set the standard amplitude calibrator for a five-millivolt square-wave output.

d. CHECK—CRT display five divisions or greater in amplitude (one millivolt/division, or less, minimum deflection factor).

20. Check Channel 1 and 2 Input Coupling Switch Operation

a. Set the CH 1 and CH 2 VOLTS/DIV switches to 20 mV.

b. Disconnect the 18-inch BNC cable and reconnect the standard amplitude calibrator to the INPUT CH 2 connector.

c. Set the standard amplitude calibrator for a 50-millivolt square-wave output.

d. Position the display with the CH 2 POSITION control so the bottom of the square wave is at the center horizontal line.

e. Set the CH 2 Input Coupling switch to GND.

f. CHECK—CRT display for straight line near the center horizontal line.

g. Set the CH 2 Input Coupling switch to AC.

h. CHECK—CRT display centered about center horizontal line.

i. Set the MODE switch to CH 1.

j. Position the display with the CH 1 POSITION control so the bottom of the square wave is at the center horizontal line.

k. Set the CH 1 Input Coupling switch to GND.

l. CHECK—CRT display for straight line near the center horizontal line.

- m. Set the CH 1 Input Coupling switch to AC.
- n. CHECK—CRT display centered about center horizontal line.

21. Check Low-Frequency Vertical Linearity

- a. Set the CH 1 and CH 2 Input Coupling switches to DC.
- b. Position the display to the center of the graticule with the CH 1 POSITION control.
- c. Adjust the CH 1 VARIABLE control for exactly two divisions of deflection.
- d. Position the top of the display to the top horizontal line.
- e. CHECK—Compression or expansion 0.1 division or less (see Fig. 6-21).
- f. Position the bottom of the display to the bottom horizontal line.
- g. CHECK—Compression or expansion 0.1 division or less (see Fig. 6-21).
- h. Set the MODE switch to CH 2.
- i. Position the display to the center of the graticule with the CH 2 POSITION control.
- j. Adjust the CH 2 VARIABLE control for exactly two divisions of deflection.
- k. Position the top of the display to the top horizontal line.
- l. CHECK—Compression or expansion 0.1 division or less (see Fig. 6-21).
- m. Position the bottom of the display to the bottom horizontal line.
- n. CHECK—Compression or expansion 0.1 division or less (see Fig. 6-21).
- o. Disconnect all test equipment.

22. Check Trace Shift Due to Input Grid Current

- a. Change the following control settings:

| | |
|-----------------------------|------|
| VOLTS/DIV (CH 1 and 2) | 5 mV |
| VARIABLE (CH 1 and 2) | CAL |
| Input Coupling (CH 1 and 2) | GND |
- b. Position the trace to the center horizontal line with the CH 2 POSITION control.
- c. CHECK—Set the CH 2 Input Coupling switch to DC and note the trace shift; 0.4 division or less.
- d. Set the MODE switch to CH 1.

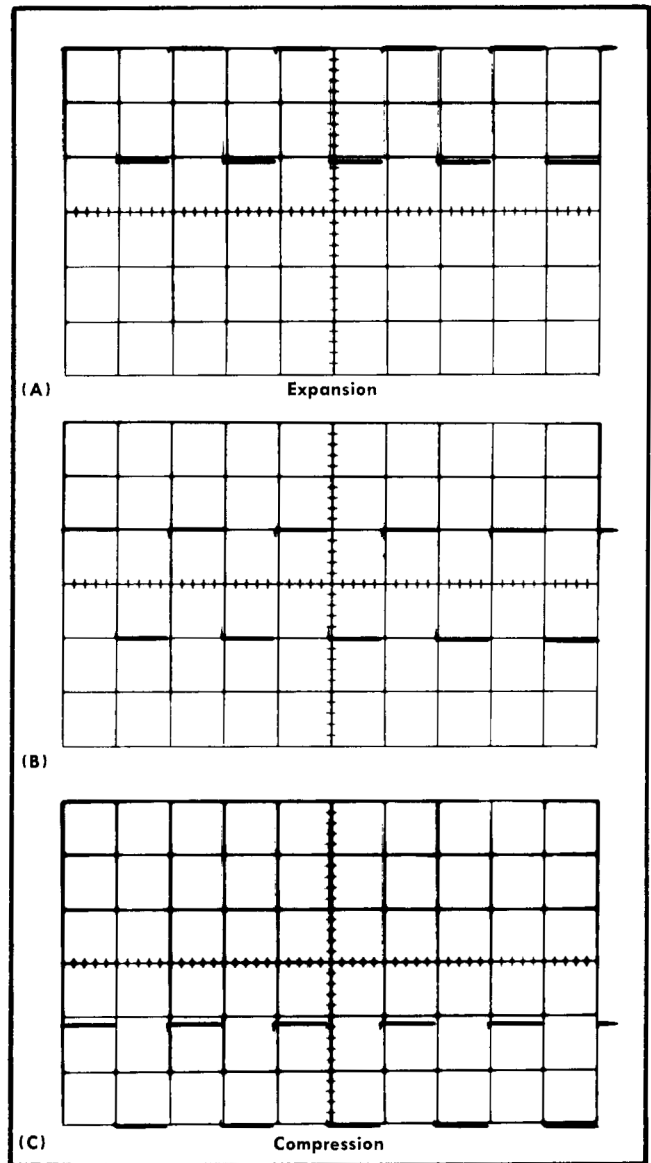

Fig. 6-21. Typical CRT display showing acceptable compression and expansion. (A) Expansion, (B) correct deflection at center of graticule, (C) compression.

- e. Position the trace to the center horizontal line with the CH 1 POSITION control.
- f. CHECK—Set the CH 1 Input Coupling switch to DC and note the trace shift; 0.4 division or less.

23. Check Alternate Operation

- a. Set the MODE switch to ALT.
- b. Position the traces about two divisions apart.
- c. Turn the A TIME/DIV switch throughout its range.
- d. CHECK—Trace alternation between Channel 1 and 2 at all sweep rates. At faster sweep rates, alternation is not apparent; instead display appears as two traces on the screen.

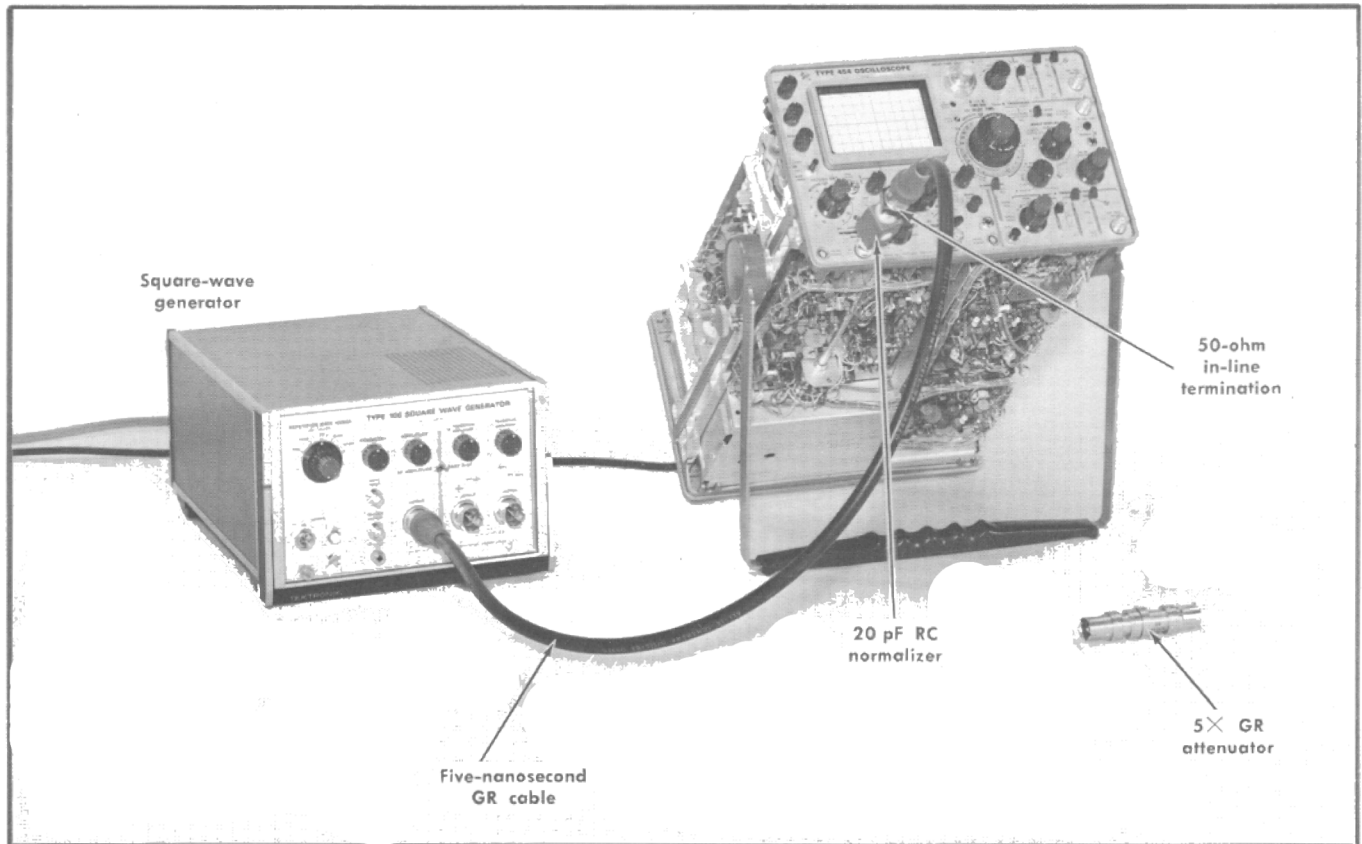

Fig. 6-22. Initial test equipment setup for steps 24 through 26.

| | |
|--|----------------------------------|
| CRT controls | |
| INTENSITY | Midrange |
| FOCUS | Adjust for focused display |
| SCALE ILLUM | As desired |
| BW-BEAM FINDER | FULL |
| Vertical controls (both channels if applicable) | |
| VOLTS/DIV | .1 |
| VARIABLE | CAL |
| POSITION | Midrange |
| Input Coupling | DC |
| MODE | CH 1 |
| TRIGGER | NORM |
| INVERT | Pushed in |
| Triggering controls (both A and B if applicable) | |
| LEVEL | Adjust for stable display |
| SLOPE | + |
| COUPLING | AC |
| SOURCE | INT |
| Sweep controls | |
| DELAY-TIME MULTIPLIER | 0.10 |
| A TIME/DIV | .2 ms |
| B TIME/DIV | .2 ms |
| A VARIABLE | CAL |

| | |
|---------------------|------------------------------|
| A SWEEP MODE | AUTO TRIG |
| B SWEEP MODE | TRIGGERABLE AFTER DELAY TIME |
| HORIZ DISPLAY | A |
| MAG | OFF |
| A SWEEP LENGTH | FULL |
| POSITION | Midrange |
| POWER | ON |
| Side-panel controls | |
| B TIME/DIV VARIABLE | CAL |

24. Adjust Channel 1 Volts/Division Switch Compensation ❶

- a. Test equipment setup is shown in Fig. 6-22.
- b. Connect the square-wave generator (Type 106) high-amplitude output connector to the INPUT CH 1 connector through the five-nanosecond GR cable, 50-ohm in-line termination and 20 pF input RC normalizer, in given order.
- c. Set the square-wave generator for four divisions of one-kilohertz signal.
- d. CHECK—CRT display at each CH 1 VOLTS/DIV switch setting listed in Table 6-2 for optimum square corner and flat top (see Fig. 6-23A, B and C).

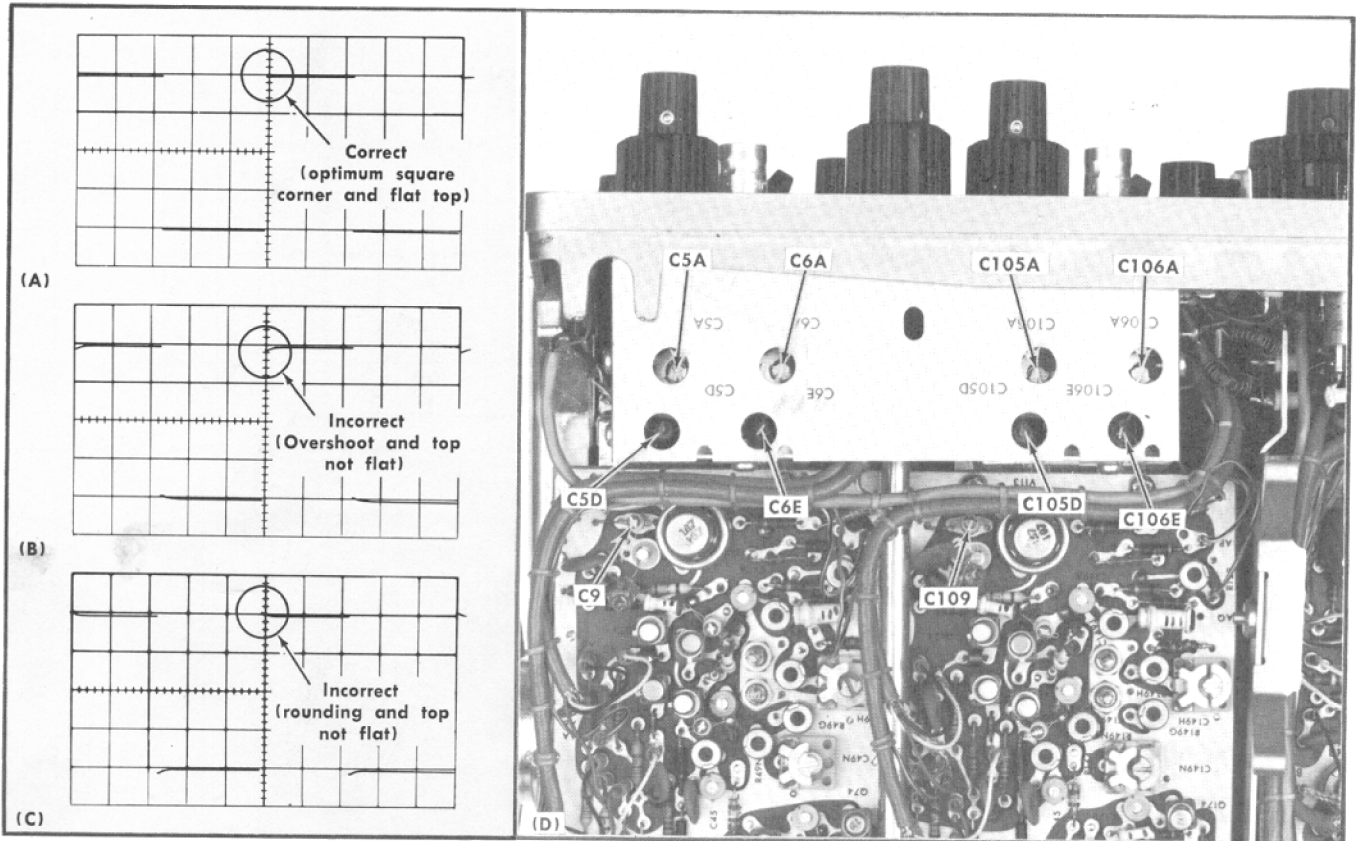

Fig. 6-23. (A) Typical CRT display showing correct compensation, (B) and (C) incorrect compensation, (D) location of compensation adjustments (bottom view).

e. ADJUST—CH 1 VOLTS/DIV switch compensation as given in Table 6-2. First adjust for optimum square corner on the display and then for optimum flat top. Readjust the generator output with each setting of the CH 1 VOLTS/DIV switch to provide four divisions of deflection (only about three divisions obtainable in 2 position). Fig. 6-23D shows the location of the variable capacitors.

TABLE 6-2

CH 1 VOLTS/DIV Switch Compensation

| CH 1 VOLTS/DIV Switch Setting | Adjust for Optimum | |
|----------------------------------|--------------------|----------|
| | Square Corner | Flat Top |
| .1 | | C9 |
| .2 | C5D | C5A |
| 2 | C6E | C6A |

25. Adjust Channel 2 Volts/Division Switch Compensation



a. Set the MODE switch to CH 2.

b. Connect the square-wave generator high-amplitude output connector to the INPUT CH 2 connector through the five-nanosecond GR cable, 50-ohm in-line termination and 20 pF input RC normalizer, in given order.

c. Set the square-wave generator for four divisions of one-kilohertz signal.

d. CHECK—CRT display at each CH 2 VOLTS/DIV switch setting listed in Table 6-3 for optimum square corner and flat top (see Fig. 6-23A, B and C).

e. ADJUST—CH 2 VOLTS/DIV switch compensation as given in Table 6-3. First adjust for optimum square corner on the display and then for optimum flat top. Readjust the generator output with each setting of the CH 2 VOLTS/DIV switch to provide four divisions of deflection (only about three divisions obtainable in 2 position). Fig. 6-23D shows the location of the variable capacitors.

f. Disconnect all test equipment.

TABLE 6-3
CH 2 VOLTS/DIV Switch Compensation

| CH 2 VOLTS/DIV Switch Setting | Adjust for Optimum | |
|----------------------------------|--------------------|----------|
| | Square Corner | Flat Top |
| .1 | | C109 |
| .2 | C105D | C105A |
| 2 | C106E | C106A |

26. Adjust Delay-Line Compensation ❶

- a. Change the following control settings:

| | |
|------------------------|-------------|
| VOLTS/DIV (CH 1 and 2) | 10 mV |
| MODE | CH 1 |
| A TIME/DIV | .05 μ s |
- b. Connect the square-wave generator fast-rise + output connector to the INPUT CH 1 connector through the five-nanosecond GR cable, 5 \times attenuator and 50-ohm in-line termination.
- c. Set the square-wave generator for fast-rise operation and four divisions output at one megahertz.
- d. CHECK—CRT display for minimum aberrations in the area about 280 nanoseconds (five to six divisions) after the rising portion of the waveform (see Fig. 6-24A).
- e. ADJUST—C402 (see Fig. 6-24B) for minimum aberrations about 280 nanoseconds (five to six divisions) after the rising portion of the waveform.
- f. CHECK—Minimum tilt of waveform top (see Fig. 6-24A).
- g. ADJUST—R417 and R419 (see Fig. 6-24B) for minimum tilt of waveform top.
- h. INTERACTION—If adjustments are made, recheck step 15.
- i. Disconnect all test equipment.

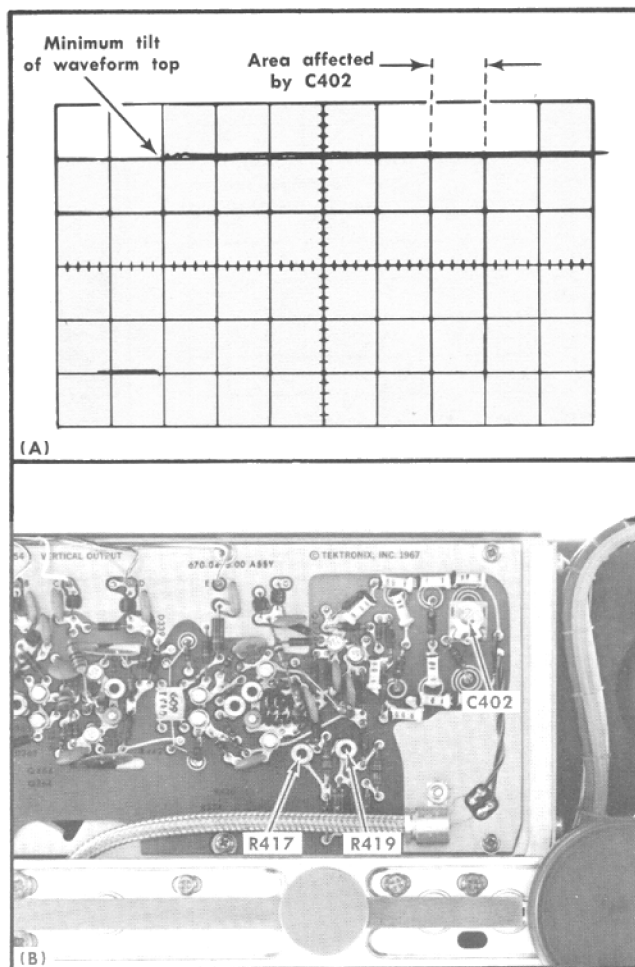

Fig. 6-24. (A) Typical CRT display showing acceptable delay-line compensation, (B) location of delay-line compensation adjustments (Vertical Output Amplifier circuit board).

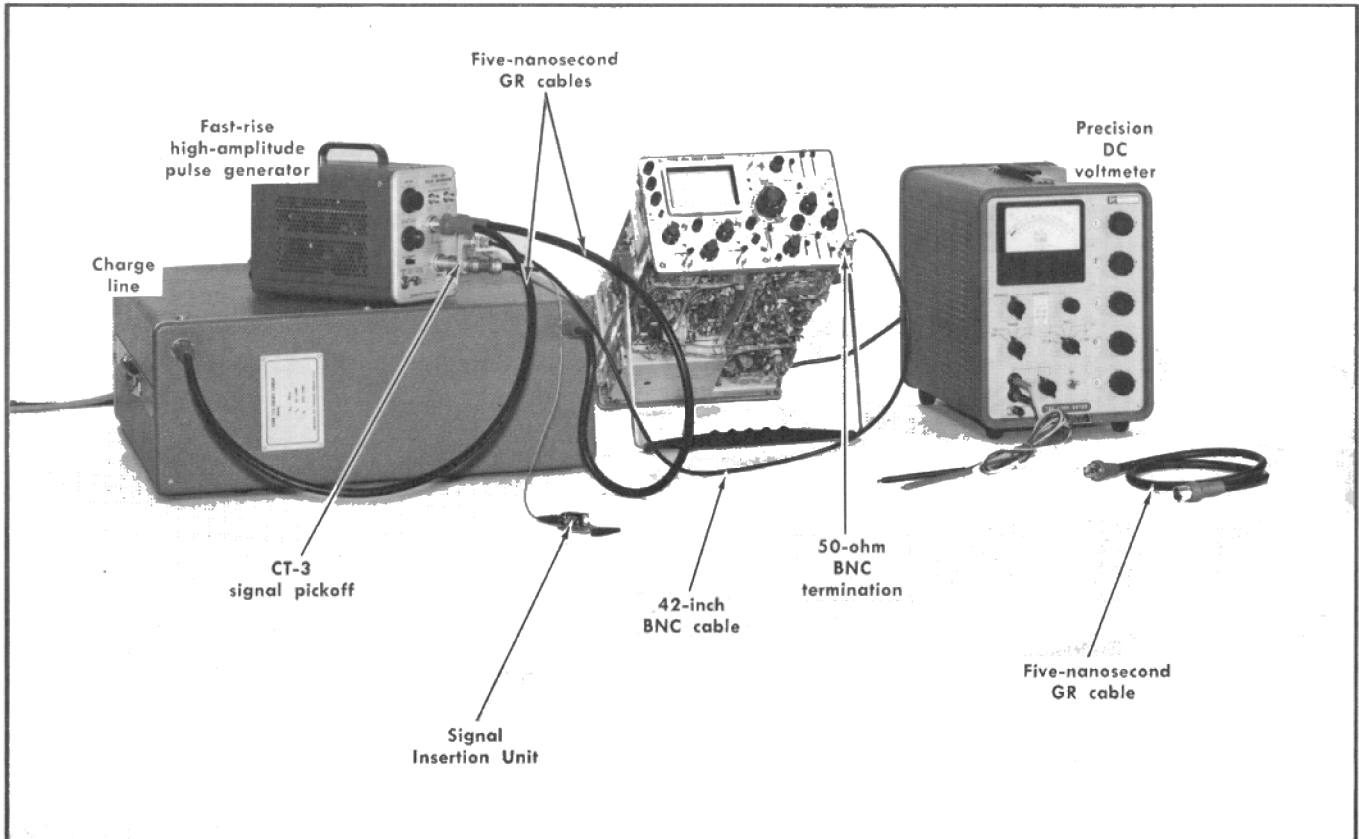

Fig. 6-25. Initial test equipment for steps 27 through 29.

CRT controls

| | |
|----------------|----------------------------|
| INTENSITY | Midrange |
| FOCUS | Adjust for focused display |
| SCALE ILLUM | As desired |
| BW-BEAM FINDER | FULL |

Vertical controls (both channels if applicable)

| | |
|----------------|-----------|
| VOLTS/DIV | 10 mV |
| VARIABLE | CAL |
| POSITION | Midrange |
| Input Coupling | DC |
| MODE | CH 1 |
| TRIGGER | NORM |
| INVERT | Pushed in |

Triggering controls (both A and B if applicable)

| | |
|---------------|----------------------------------|
| LEVEL | Adjust for stable display |
| SLOPE | + |
| COUPLING | AC |
| SOURCE | EXT |

Sweep controls

| | |
|-----------------------|------------|
| DELAY-TIME MULTIPLIER | 0.10 |
| A TIME/DIV | .1 μ s |
| B TIME/DIV | .1 μ s |

A VARIABLE

A SWEEP MODE
B SWEEP MODE

HORIZ DISPLAY

MAG
A SWEEP LENGTH
POSITION
POWER

Side-panel controls

B TIME/DIV VARIABLE CAL

CAL

AUTO TRIG
TRIGGERABLE AFTER
DELAY TIME

A

$\times 10$
FULL
Midrange
ON

27. Adjust Output Amplifier High-Frequency Compensation

a. Test equipment setup is shown in Fig. 6-25. (Note: The following procedure gives a different setup which supersedes that shown in Fig. 6-25.)

b. Disconnect the jumper connectors at the input to the delay line (Vertical Preamp circuit board; see Fig. 6-26A).

c. Connect the signal insertion unit to the input of the delay line. Connect the alligator clip to pin AR (−12 volts, see Fig. 6-26A) on the Vertical Preamp circuit board.

d. Note the exact position of the trace so R334 can be returned to the correct adjustment in part s of this step.

Calibration—Type 454/R454

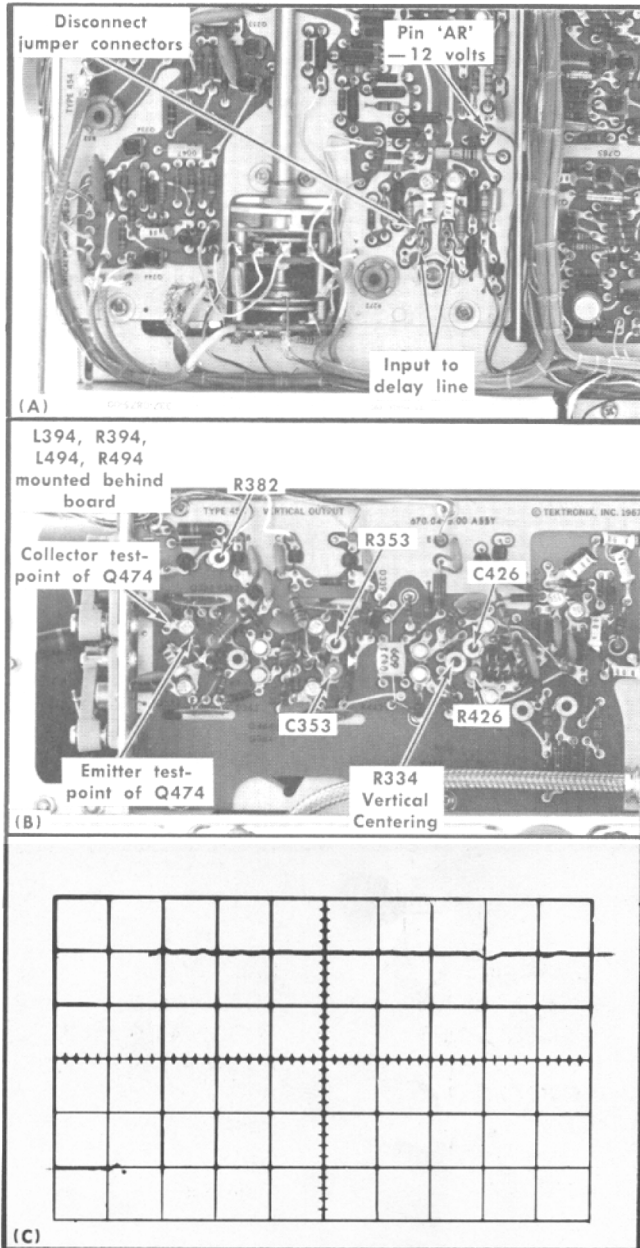

Fig. 6-26. (A) Location of test points for output-amplifier driver (Vertical Preamp circuit board), (B) location of Output Amplifier compensation adjustments (Vertical Output Amplifier circuit board), (C) typical CRT display showing correct high-frequency compensation.

e. Position the trace to the center horizontal line of the graticule with the Vertical Centering adjustment R334 (see Fig. 6-26B).

f. Connect the precision DC voltmeter between the collector and emitter test-points of Q474 (see Fig. 6-26B).

g. CHECK—Meter reading, 2.9 volts.

h. ADJUST—R382 (see Fig. 6-26B) for 2.9 volts difference between the collector and emitter of Q474.

i. Disconnect the precision DC voltmeter.

j. Connect the fast-rise, high-amplitude pulse generator (Type 109) 50 Ω output connector to the signal insertion unit through the CT-3.

k. Connect the signal pickoff connector of the CT-3 to the A EXT TRIG INPUT connector through a 50-ohm BNC cable and the 50-ohm BNC termination.

l. Connect the charge line (Type 113) directly to the charge line 1 connector of the fast-rise, high-amplitude pulse generator with a 50-ohm GR elbow. Support the pulse generator as necessary to make this connection. Connect a GR short circuit termination to the charge line 2 connector.

m. Set the fast-rise, high-amplitude pulse generator for a four-division pulse.

n. Adjust the A LEVEL control for a stable display.

o. Center the display vertically with the Vertical Centering adjustment, R334.

p. CHECK—CRT display for optimum risetime and flat top (see Fig. 6-26C).

q. ADJUST—If greater than 3% aberrations are observed (disregard first six nanoseconds after leading edge), use the following adjustment procedure (see Fig. 6-26B for location of adjustments). If less than 3%, proceed to part r.

NOTE

Change the MAG switch from $\times 10$ to OFF and compare the response at both sweep rates. Then adjust for the best overall response.

1. Preset R394 and R494 to midrange.

2. Adjust L394 and L494 for smoothest pulse top after the first six nanoseconds.

3. Adjust R394 and R494 to remove fast wrinkles after the first six nanoseconds.

4. Repeat 2 and 3 for best overall response after the first six nanoseconds.

5. Proceed to r.

r. ADJUST—See Fig. 6-26B for location of adjustments.

1. Set C426 to minimum capacitance and R426 to mid-range.

2. Adjust C353 and R353 for optimum risetime and flat top.

3. Adjust R426 for optimum square corner.

4. Adjust C426 for optimum square corner.

5. Adjust L394 and L494 for smoothest pulse top after the first six nanoseconds.

6. Adjust R394 and R494 to remove fast wrinkles after the first six nanoseconds.

7. Repeat 1 through 6 for optimum pulse response.

s. ADJUST—Vertical-Centering adjustment, R334 (see Fig. 6-26B), to return the trace to the same position noted in part d of this step. (If the correct adjustment for R334 is not known, adjust Vertical Centering as given in step 13).

t. Disconnect all test equipment.

u. Replace the jumper connectors at the input to the delay line.

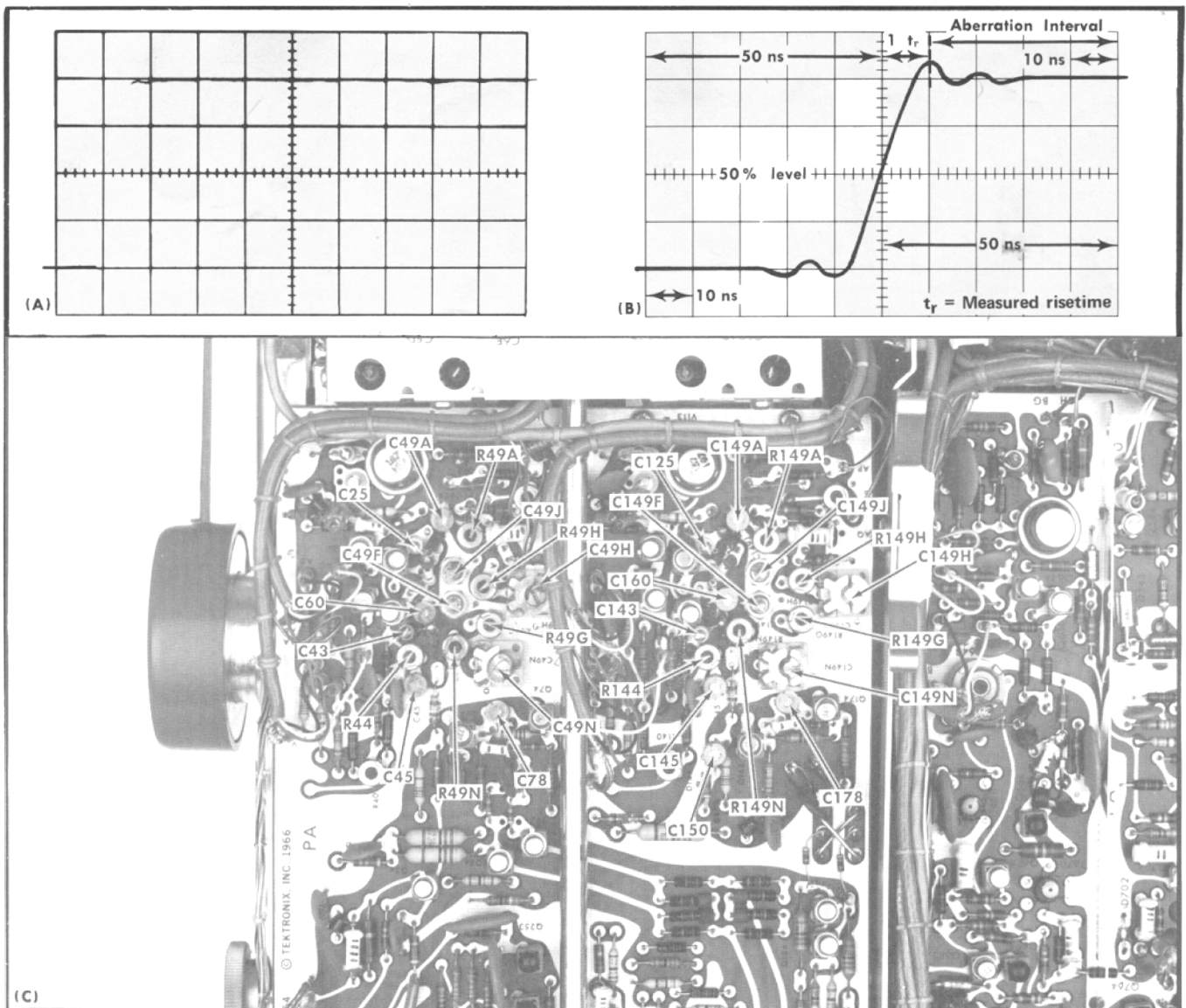

Fig. 6-27. (A) Typical CRT display showing correct Channel 1 and 2 compensation (shown at vertical deflection of 10 mV/DIV and sweep rate of 10 nanoseconds/division), (B) idealized waveform showing areas used for aberration check, (C) location of Channel 1 and 2 compensation adjustments (Vertical Preamp circuit board).

28. Adjust Channel 1 High-Frequency Compensation

a. Connect the fast-rise, high-frequency pulse generator 50 Ω output connector to the CH 1 INPUT connector through a five-nanosecond GR cable and the 50-ohm in-line termination. Leave the charge line connected as in step 27.

b. Change the following control settings:

| | |
|------------------|--------|
| CH 1 VOLTS/DIV | 10 mV |
| A SOURCE | INT |
| A and B TIME/DIV | .05 μs |
| MAG | ×10 |

NOTE

The trace alignment and geometry must be correct to perform this step. Check steps 8 and 9 of this procedure to assure correct operation if only steps 28 and 29 are to be performed.

c. Set the fast-rise, high-amplitude pulse generator for a four-division pulse centered vertically and horizontally on the CRT (adjust the A LEVEL control for a stable display).

d. Measure and note the risetime between the 10% and 90% points of the step.

e. Set the A and B TIME/DIV switch to .1 μs.

f. Center the pulse with the horizontal POSITION control. Recheck the amplitude of the pulse and readjust the generator output for four divisions, if necessary, using the first

Calibration—Type 454/R454

and last division of the graticule as the reference areas (see Fig. 6-27B). If there are any aberrations within the reference areas, use the average levels as the reference. Using this technique, the average level within the first division of the graticule should be positioned to the second horizontal line below the center line and the average level within the last division of the graticule should be positioned to the second horizontal line above the center line. After the pulse is positioned vertically, adjust the horizontal POSITION control so the rising portion of the waveform crosses the center horizontal line exactly at the center vertical line (50% point of step at center vertical line).

g. CHECK—CRT display for a flat top and square corner within ± 0.24 division or -0.24 division, or total peak-to-peak aberrations within 0.24 division (peak aberrations $\pm 6\%$ or -6% ; peak-to-peak aberrations within 6%). Make this measurement within the area one risetime (as measured in part d) to the right of the vertical center line and the last vertical line of the graticule.

h. ADJUST—R44, C49F and R49G (see Fig. 6-27C) for optimum square-wave response.

NOTE

R44, C45 and C78 affect the response at all deflection factors. R44 is adjusted for optimum response at 10 and 20 mV/DIV. C45 is adjusted for optimum response at 20 and 50 mV/DIV. C78 is adjusted for a risetime of 2.4 nanoseconds or less at 20 mV/DIV.

i. Change the following control settings:

| | |
|------------------|-------------|
| CH 1 VOLTS/DIV | 5 mV |
| A and B TIME/DIV | .05 μ s |

j. Set the fast-rise, high-amplitude pulse generator for a four-division pulse centered vertically and horizontally on the CRT.

k. Measure and note the risetime between the 10% and 90% points of the step.

l. Set the A and B TIME/DIV switch to .1 μ s.

m. Center the display vertically and horizontally using the technique given in part f.

n. CHECK—CRT display for a flat top and square corner within ± 0.28 division or -0.28 division, or total peak-to-peak aberrations within 0.28 division (peak aberrations $\pm 7\%$ or -7% ; peak-to-peak aberrations within 7%). Make this measurement within the area one risetime (as measured in part k) to the right of the vertical center line and the last vertical line of the graticule.

NOTE

The waveform response at 5 mV, 20 mV, 50 mV and .1 V will be slightly different from that shown in Fig. 6-27A due to the differing risetimes and compensation adjustments in each position.

o. ADJUST—C49A and R49A (see Fig. 6-27C) for optimum square-wave response.

p. Change the following control settings:

| | |
|------------------|-------------|
| CH 1 VOLTS/DIV | 20 mV |
| A and B TIME/DIV | .05 μ s |

q. Set the fast-rise, high-amplitude pulse generator for a four-division pulse centered vertically and horizontally on the CRT.

r. Measure and note the risetime between the 10% and 90% points of the step.

s. Set the A and B TIME/DIV switch to .1 μ s.

t. Center the display vertically and horizontally using the technique given in part f.

u. CHECK—CRT display for a flat top and square corner within ± 0.2 division or -0.2 division, or total peak-to-peak aberrations within 0.2 division (peak aberrations $\pm 5\%$ or -5% ; peak-to-peak aberrations within 5%). Make this measurement within the area one risetime (as measured in part r) to the right of the vertical center line and the last vertical line of the graticule.

v. ADJUST—C45, C49H, R49H and C49J (see Fig. 6-27C) for optimum square-wave response. Set C78 for a risetime of 2.4 nanoseconds or less.

NOTE

R44 has a large effect on the 20 mV response. It may be necessary to compromise the adjustment of R44 at 10 and 20 mV for best overall response.

w. Set the CH 1 VOLTS/DIV switch to .2.

x. Set the fast-rise, high-amplitude pulse generator for a four-division pulse.

y. CHECK—Optimum square-wave response similar to that obtained in part u and v.

z. ADJUST—If necessary, compromise the adjustment of C45, C49H, R49H and C49J for optimum square-wave response at both 20 mV and .2.

aa. Change the following control settings:

| | |
|------------------|-------------|
| CH 1 VOLTS/DIV | 50 mV |
| A and B TIME/DIV | .05 μ s |

ab. Set the fast-rise, high-amplitude pulse generator for a four-division pulse centered vertically and horizontally on the CRT.

ac. Measure and note the risetime between the 10% and 90% points of the step.

ad. Set the A and B TIME/DIV switch to .1 μ s.

ae. Center the display vertically and horizontally using the technique given in part f.

af. CHECK—CRT display for a flat top and square corner within ± 0.2 or -0.2 division, or total peak-to-peak aberrations within 0.2 division (peak aberrations $\pm 5\%$ or -5% ; peak-to-peak aberrations within 5%). Make this measurement within the area one risetime (as measured in part ac) to the right of the vertical center line and the last vertical line of the graticule.

ag. ADJUST—C43, C49N, R49N and C60 (see Fig. 6-27B) for optimum square-wave response. C60 has the greatest affect on 50 mV response.

NOTE

C45 also affects the 50 mV response. It may be necessary to compromise the adjustment of C45 at 20 and 50 mV for best overall response.

- ah. Set the CH 1 VOLTS/DIV switch to .5.
- ai. Set the fast-rise, high-amplitude pulse generator for a four-division pulse.
- aj. CHECK—Optimum square-wave response similar to that obtained in part af or ag.
- ak. ADJUST—If necessary, compromise the adjustment of C43, C49N, R49N and C60 for optimum square-wave response at both 50 mV and .5.
- al. Change the following control settings:

| | |
|------------------|-------------|
| CH 1 VOLTS/DIV | .1 |
| A and B TIME/DIV | .05 μ s |
- am. Set the fast-rise, high-amplitude pulse generator for a four-division pulse centered vertically and horizontally on the CRT.
- an. Measure and note the risetime between the 10% and 90% points of the step.
- ao. Set the A and B TIME/DIV switch to .1 μ s.
- ap. Center the display vertically and horizontally using the technique given in part f.
- aq. CHECK—CRT display for a flat top and square corner within +0.28 or -0.28 division, or total peak-to-peak aberrations within 0.28 division (peak aberrations +7% or -7%; peak-to-peak aberrations within 7%). Make this measurement within the area one risetime (as measured in part an) to the right of the vertical center line and the last vertical line of the graticule.
- ar. ADJUST—C25 (see Fig. 6-27C) for optimum square-wave response.

29. Adjust Channel 2 High-Frequency Compensation ①

- a. Disconnect the output of the 50-ohm in-line termination from the INPUT CH 1 connector and connect it to the INPUT CH 2 connector.
- b. Set the MODE switch to CH 2.
- c. Set the fast-rise, high-amplitude pulse generator for a four-division pulse (CH 2 VOLTS/DIV switch set to 10 mV) centered vertically and horizontally on the CRT.
- d. Measure and note the risetime between the 10% and 90% points of the step.
- e. Set the A and B TIME/DIV switch to .1 μ s.
- f. Center the display vertically and horizontally using the technique given in step 28 f.
- g. CHECK—CRT display for a flat top and square corner within +0.24 division or -0.24 division, or total peak-to-peak aberrations within 0.24 division (peak aberrations +6% or -6%; peak-to-peak aberrations within 6%; see Fig. 6-27A).

Make this measurement within the area one risetime (as measured in part d) to the right of the vertical center line and the last vertical line of the graticule.

- h. ADJUST—R144, C149F and R149G (see Fig. 6-27C) for optimum square-wave response.

NOTE

R144, C145, C150 and C178 affect the response at all deflection factors. R144 is adjusted for optimum response at 10 and 20 mV/DIV. C145 and C150 are adjusted for optimum response at 20 and 50 mV/DIV. C178 is adjusted for a risetime of 2.4 nanoseconds at 20 mV/DIV.

- i. Change the following control settings:

| | |
|------------------|-------------|
| CH 2 VOLTS/DIV | 5 mV |
| A and B TIME/DIV | .05 μ s |
- j. Set the fast-rise, high-amplitude pulse generator for a four-division pulse centered vertically and horizontally on the CRT.
- k. Measure and note the risetime between the 10% and 90% points of the step.
- l. Set the A and B TIME/DIV switch to .1 μ s.
- m. Center the display vertically and horizontally using the technique given in step 28 f.
- n. CHECK—CRT display for a flat top and square corner within +0.28 division or -0.28 division, or total peak-to-peak aberrations within 0.28 division (peak aberration +7% or -7%; peak-to-peak aberrations within 7%). Make this measurement within the area one risetime (as measured in part k) to the right of the vertical center line and the last vertical line of the graticule.
- o. ADJUST—C149A and R149A (see Fig. 6-27C) for optimum square-wave response.
- p. Change the following control settings:

| | |
|------------------|-------------|
| CH 2 VOLTS/DIV | 20 mV |
| A and B TIME/DIV | .05 μ s |
- q. Set the fast-rise, high-amplitude pulse generator for a four-division pulse centered vertically and horizontally on the CRT.
- r. Measure and note the risetime between the 10% and 90% points of the step.
- s. Set the A and B TIME/DIV switch to .1 μ s.
- t. Center the display vertically and horizontally using the technique given in step 28 f.
- u. CHECK—CRT display for a flat top and square corner within +0.2 division or -0.2 division, or total peak-to-peak aberrations within 0.2 division (peak aberrations +5% or -5%; peak-to-peak aberrations within 5%). Make this measurement within the area one risetime (as measured in part r) to the right of the vertical center line and the last vertical line of the graticule.
- v. ADJUST—C145, C149H, R149H, C149J and C150 (see Fig. 6-27C) for optimum square-wave response (C150 adjustable above SN B040000 only). Set C178 for a risetime of 2.4 nanoseconds or less.

Calibration—Type 454/R454

NOTE

R144 has a large effect on the 20 mV response. It may be necessary to compromise the adjustment of R144 at 20 and 50 mV for best overall response.

- w. Set the CH 2 VOLTS/DIV switch to .2.
- x. Set the fast-rise, high-amplitude pulse generator for a four-division pulse.
- y. CHECK—Optimum square-wave response similar to that obtained in part u or v.
- z. ADJUST—If necessary, compromise the adjustment of C145, C149H, R149H and C149J for optimum square-wave response at both 20 mV and .2.
- aa. Change the following control settings:
- | | |
|------------------|-------------|
| CH 2 VOLTS/DIV | 50 mV |
| A and B TIME/DIV | .05 μ s |
- ab. Set the fast-rise, high-amplitude pulse generator for a four-division pulse centered vertically and horizontally on the CRT.
- ac. Measure and note the risetime between the 10% and 90% points of the step.
- ad. Set the A and B TIME/DIV switch to .1 μ s.
- ae. Center the display vertically and horizontally using the technique given in step 28 f.
- af. CHECK—CRT display for a flat top and square corner within +0.2 or -0.2 division, or total peak-to-peak aberrations within 0.2 division (peak aberrations +5% to -5%; peak-to-peak aberrations within 5%). Make this measurement within the area one risetime (as measured in part ac) to the right of the vertical center line and the last vertical line of the graticule.
- ag. ADJUST—C143, C149N, R149N, and C160 (see Fig. 6-27C) for optimum square-wave response. C160 has the greatest effect on 50 mV response.

NOTE

C145 and C150 also affect the 50 mV response. It may be necessary to compromise the adjustment of C145 and C150 at 20 and 50 mV for best overall response.

- ah. Set the CH 2 VOLTS/DIV switch to .5.
- ai. Set the fast-rise, high-amplitude pulse generator for a four-division pulse.
- aj. CHECK—Optimum square-wave response similar to that obtained in part af or ag.
- ak. ADJUST—If necessary, compromise the adjustment of C143, C149N, R149N and C160 for optimum response at both 50 mV and .5.
- al. Change the following control settings:
- | | |
|------------------|-------------|
| CH 2 VOLTS/DIV | .1 |
| A and B TIME/DIV | .05 μ s |
- am. Set the fast-rise, high-amplitude pulse generator for a four-division pulse centered vertically and horizontally on the CRT.
- an. Measure and note the risetime between the 10% and 90% points of the step.
- ao. Set the A and B TIME/DIV switch to .1 μ s.
- ap. Center the display vertically and horizontally using the technique given in step 28 f.
- aq. CHECK—CRT display for a flat top and square corner within +0.28 or -0.28 division, or total peak-to-peak aberrations within 0.28 division (peak aberrations +7% or -7%; peak-to-peak aberrations within 7%). Make this measurement within the area one risetime (as measured in part an) to the right of the vertical center line and the last vertical line of the graticule.
- ar. ADJUST—C125 (see Fig. 6-27C) for optimum square-wave response.
- as. Disconnect all test equipment.

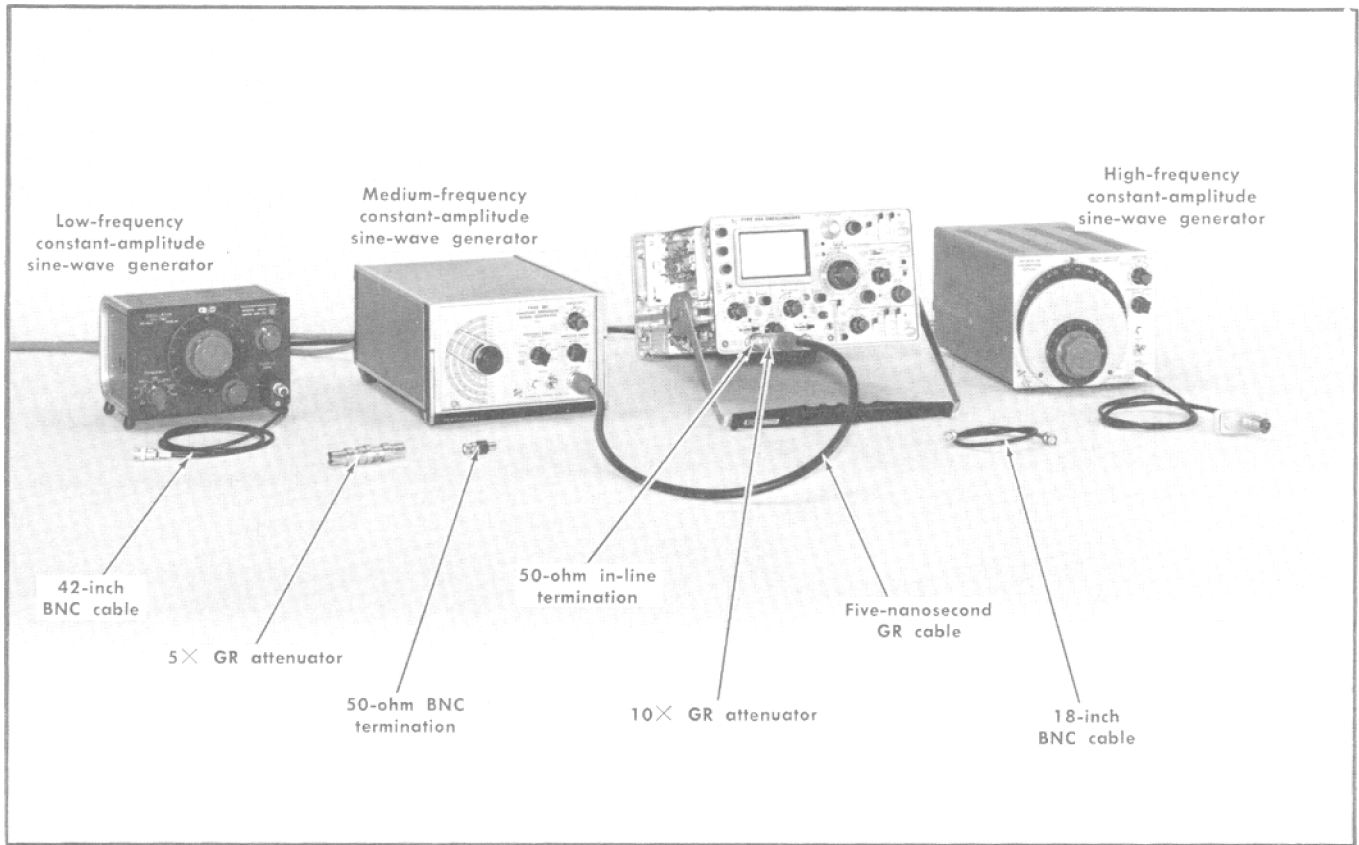

Fig. 6-28. Initial test equipment setup for steps 30 through 35.

| | |
|--|----------------------------|
| CRT controls | |
| INTENSITY | Midrange |
| FOCUS | Adjust for focused display |
| SCALE ILLUM | As desired |
| BW-BEAM FINDER | FULL |
| Vertical controls (both channels if applicable) | |
| VOLTS/DIV | .1 |
| VARIABLE | CAL |
| POSITION | Midrange |
| Input Coupling | DC |
| MODE | CH 1 |
| TRIGGER | NORM |
| INVERT | Pushed in |
| Triggering controls (both A and B if applicable) | |
| LEVEL | Any position |
| SLOPE | + |
| COUPLING | AC |
| SOURCE | INT |
| Sweep controls | |
| DELAY-TIME MULTIPLIER | 0.10 |
| A TIME/DIV | 2 μs |

| | |
|---------------------|------------------------------|
| B TIME/DIV | 2 μs |
| A VARIABLE | CAL |
| A SWEEP MODE | AUTO TRIG |
| B SWEEP MODE | TRIGGERABLE AFTER DELAY TIME |
| HORIZ DISPLAY | A |
| MAG | OFF |
| A SWEEP LENGTH | FULL |
| POSITION | Midrange |
| POWER | ON |
| Side-panel controls | |
| B TIME/DIV VARIABLE | CAL |

30. Check 0.1 Volt, 50 mV, 20 mV and 10 mV Bandwidth of Channel 1 and 2

- a. Test equipment setup is shown in Fig. 6-28.
- b. Connect the high-frequency constant-amplitude sine-wave generator (067-0532-00) to the INPUT CH 1 connector through the 10 \times GR attenuator and 50-ohm in-line termination, in given order.
- c. Set the high-frequency generator for a four-division display at its reference frequency (3 MHz).
- d. Change the high-frequency generator to the variable frequency position.

Calibration—Type 454/R454

e. Without changing the output amplitude, increase the output frequency of the generator until the display is reduced to 2.8 divisions (-3 dB point; see Fig. 6-29).

f. CHECK—Output frequency of generator must be 150 megahertz or higher.

g. Set the CH 1 VOLTS/DIV switch to 50 mV.

h. Set the high-frequency generator for a four-division display at its reference frequency (3 MHz).

i. Set the high-frequency generator to the variable frequency position.

j. Without changing the output amplitude, increase the output frequency of the generator until the display is reduced to 2.8 divisions (-3 dB point).

k. CHECK—Output frequency of generator must be 150 megahertz or higher.

l. Set the CH 1 VOLTS/DIV switch to 20 mV.

m. Insert the $5\times$ GR attenuator between the $10\times$ GR attenuator and the 50-ohm in-line termination.

n. Set the high-frequency generator for a four-division display at its reference frequency (3 MHz).

o. Set the high-frequency generator to the variable frequency position.

p. Without changing the output amplitude, increase the output frequency of the generator until the display is reduced to 2.8 divisions (-3 dB point).

q. CHECK—Output frequency of generator must be 150 megahertz or higher.

r. Set the CH 1 VOLTS/DIV switch to 10 mV.

s. Set the high-frequency generator for a four-division display at its reference frequency (3 MHz).

t. Change the high-frequency generator to the variable frequency position.

u. Without changing the output amplitude, increase the output frequency of the generator until the deflection is reduced to 2.8 divisions (-3 dB point).

v. CHECK—Output frequency of generator must be 100 megahertz or higher.

w. Set the MODE switch to CH 2.

x. Disconnect the output of the in-line termination from the INPUT CH 1 connector and connect it to the INPUT CH 2 connector.

y. Remove the $5\times$ GR attenuator.

z. Set the high-frequency generator for a four-division display at its reference frequency (3 MHz).

aa. Set the high-frequency generator to the variable frequency position.

ab. Without changing the output amplitude, increase the output frequency of the generator until the deflection is reduced to 2.8 divisions (-3 dB point).

ac. CHECK—Output frequency of generator must be 150 megahertz or higher.

ad. Set the CH 2 VOLTS/DIV switch to 50 mV.

ae. Set the high-frequency generator for a four-division display at its reference frequency (3 MHz).

af. Set the high-frequency generator to the variable frequency position.

ag. Without changing the output amplitude, increase the output frequency of the generator until the display is reduced to 2.8 divisions (-3 dB point).

ah. CHECK—output frequency of generator must be 150 megahertz or higher.

ai. Set the CH 2 VOLTS/DIV switch to 20 mV.

aj. Insert the $5\times$ GR attenuator between the $10\times$ GR attenuator and the 50-ohm in-line termination.

ak. Set the high-frequency generator for a four-division display at its reference frequency (3 MHz).

al. Set the high-frequency generator to the variable frequency position.

am. Without changing the output amplitude, increase the output frequency of the generator until the display is reduced to 2.8 divisions (-3 dB point).

an. CHECK—Output frequency of generator must be 150 megahertz or higher.

ao. Set the CH 2 VOLTS/DIV switch to 10 mV.

ap. Set the high-frequency generator for a four-division display at its reference frequency (3 MHz).

aq. Set the high-frequency generator to the variable frequency position.

ar. Without changing the output amplitude, increase the output frequency of the generator until the deflection is reduced to 2.8 divisions (-3 dB point).

as. CHECK—Output frequency of generator must be 100 megahertz or higher.

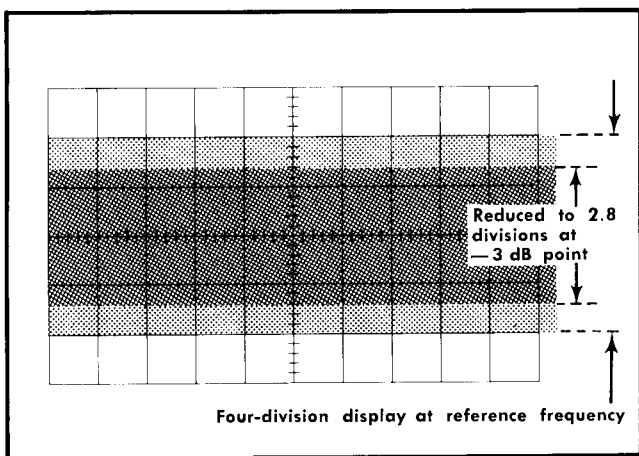

Fig. 6-29. Typical CRT display when checking vertical bandwidth.

31. Check Added Mode Bandwidth

- a. Change the following control settings:

| | |
|------------------------|----------|
| VOLTS/DIV (CH 1 and 2) | 20 mV |
| CH 1 POSITION | Midrange |
| CH 1 Input Coupling | GND |
| MODE | ADD |
- b. Set the high-frequency generator for a four-division display at its reference frequency (3 MHz).
- c. Set the high-frequency generator to its variable frequency position.
- d. Without changing the output amplitude, increase the output frequency of the generator until the deflection is reduced to 2.8 divisions (−3 dB point; see Fig. 6-29).
- e. CHECK—Output frequency of generator must be 150 megahertz or higher.
- f. Change the following control settings:

| | |
|---------------------|----------|
| CH 2 POSITION | Midrange |
| CH 1 Input Coupling | DC |
| CH 2 Input Coupling | GND |
- g. Disconnect the output of the in-line termination from the INPUT CH 2 connector and connect it to the INPUT CH 1 connector.
- h. Set the high-frequency generator for a four-division display at its reference frequency (3 MHz).
- i. Set the high-frequency generator to its variable frequency position.
- j. Without changing the output amplitude, increase the output frequency of the generator until the deflection is reduced to 2.8 divisions (−3 dB point; see Fig. 6-29).
- k. CHECK—Output frequency of generator must be 150 megahertz or higher.
- l. Disconnect all test equipment.

32. Check 5 mV Bandwidth of Channel 1 and 2

- a. Change the following control settings:

| | |
|------------------------|-------|
| VOLTS/DIV (CH 1 and 2) | 5 mV |
| CH 2 Input Coupling | DC |
| MODE | CH 2 |
| A and B TIME/DIV | .1 ms |
- b. Connect the medium-frequency constant-amplitude sine-wave generator (Type 191) to the INPUT CH 2 connector through a five-nanosecond GR cable, 10× GR attenuator and the 50-ohm in-line termination.
- c. Set the medium-frequency generator for a four-division display at its reference frequency (50 kHz).

- d. Set the medium-frequency generator to its variable frequency position.
- e. Without changing the output amplitude, increase the output frequency of the generator until the deflection is reduced to 2.8 divisions (−3 dB point; see Fig. 6-29).
- f. CHECK—Output frequency of generator must be 60 megahertz or higher.
- g. Set the MODE switch to CH 1.
- h. Disconnect the output of the in-line termination from the INPUT CH 2 connector and connect it to the INPUT CH 1 connector.
- i. Set the medium-frequency generator for a four-division display at its reference frequency (50 kHz).
- j. Set the medium-frequency generator to its variable frequency position.
- k. Without changing the output amplitude, increase the output frequency of the generator until the deflection is reduced to 2.8 divisions (−3 dB point; see Fig. 6-29).
- l. CHECK—Output frequency of generator must be 60 megahertz or higher.

33. Check Channel 1 and 2 Cascaded Bandwidth

- a. Connect the CH 1 OUT connector to the INPUT CH 2 connector with an 18-inch, 50-ohm BNC cable.
- b. Set the MODE switch to CH 2.
- c. Set the medium-frequency generator for a four-division display at its reference frequency (50 kHz).
- d. Set the medium-frequency generator to the variable frequency position.
- e. Without changing the output amplitude, increase the output frequency of the generator until the deflection is reduced to 2.8 divisions (−3 dB point; see Fig. 6-29).
- f. CHECK—Output frequency of generator must be 33 megahertz or higher.
- g. Disconnect the cable from between the CH 1 OUT and INPUT CH 2 connectors.

34. Check Bandwidth Limiter Operation

- a. Change the following control settings:

| | |
|------------------------|------------|
| VOLTS/DIV (CH 1 and 2) | 20 mV |
| MODE | CH 1 |
| BW-BEAM FINDER | 5 MHz (up) |
- b. Set the medium-frequency generator for a four-division display at its reference frequency (50 kHz).

Calibration—Type 454/R454

- c. Set the medium-frequency generator to its variable frequency position.
- d. Without changing the output amplitude, increase the output frequency of the generator until the deflection is reduced to 2.8 divisions (−3 dB point; see Fig. 6-29).
- e. CHECK—Output frequency of generator must be four megahertz or higher and six megahertz or less.
- f. Disconnect all test equipment.

35. Check Low-Frequency, AC Coupled Bandwidth

- a. Connect the low-frequency constant-amplitude generator to the INPUT CH 1 connector through the 42-inch 50-ohm BNC cable and the 50-ohm BNC termination.
- b. Change the following control settings:

| | |
|----------------------|------|
| Input Coupling (CH 1 | AC |
| and 2) | |
| A and B TIME/DIV | .1 s |

- c. Set the low-frequency generator for a four-division display at one kilohertz.
- d. Without changing the output amplitude, reduce the output frequency of the generator until the deflection is reduced to 2.8 divisions (−3 dB point; see Fig. 6-29).
- e. CHECK—Output frequency of generator must be 10 hertz or less.
- f. Set the MODE switch to CH 2.
- g. Disconnect the output of the 50-ohm termination from the INPUT CH 1 connector and connect it to the INPUT CH 2 connector.
- h. Set the low-frequency generator for a four-division display at one kilohertz.
- i. Without changing the output amplitude, reduce the output frequency of the generator until the deflection is reduced to 2.8 divisions (−3 dB point; see Fig. 6-29).
- j. CHECK—Output frequency of generator must be 10 hertz or less.
- k. Disconnect all test equipment.

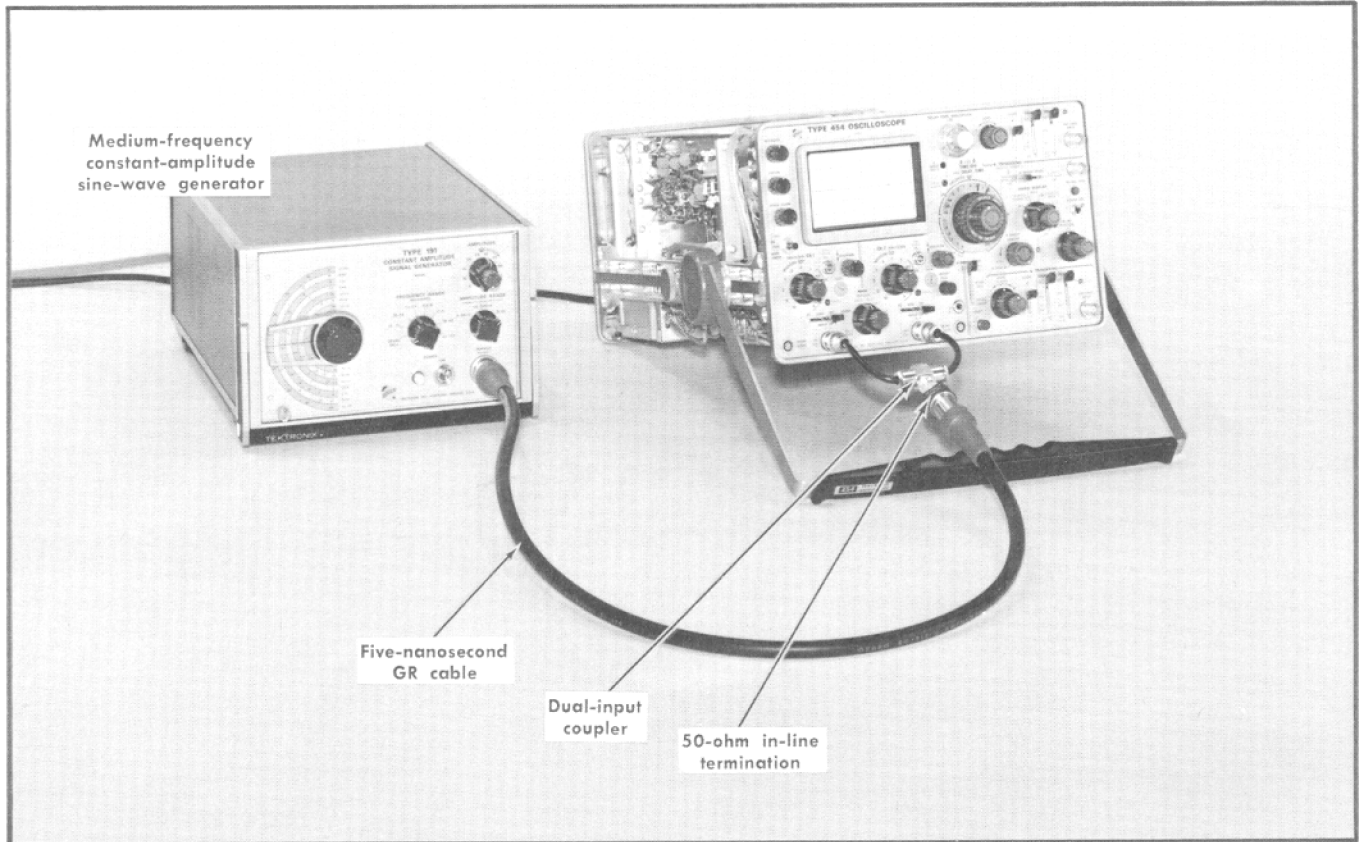

Fig. 6-30. Initial test equipment setup for steps 36 through 38.

- | | | | |
|--|----------------------------|------------------------|-------------------|
| CRT controls | | A SWEEP MODE | AUTO TRIG |
| INTENSITY | Midrange | B SWEEP MODE | TRIGGERABLE AFTER |
| FOCUS | Adjust for focused display | | DELAY TIME |
| SCALE ILLUM | As desired | HORIZ DISPLAY | A |
| BW-BEAM FINDER | FULL | MAG | OFF |
| | | A SWEEP LENGTH | FULL |
| Vertical controls (both channels if applicable) | | POSITION | Midrange |
| VOLTS/DIV | 50 mV | POWER | ON |
| VARIABLE | CAL | Side-panel controls | |
| POSITION | Midrange | B TIME/DIV VARIABLE | CAL |
| INPUT COUPLING | DC | | |
| MODE | CH 1 | | |
| TRIGGER | NORM | | |
| INVERT | Pushed in | | |
| Triggering controls (both A and B if applicable) | | | |
| LEVEL | Any position | | |
| SLOPE | + | | |
| COUPLING | AC | | |
| SOURCE | INT | | |
| Sweep controls | | | |
| DELAY-TIME MULTIPLIER | 0.10 | | |
| A TIME/DIV | .1 ms | VOLTS/DIV (CH 1 and 2) | 20 mV |
| B TIME/DIV | .1 ms | MODE | ADD |
| A VARIABLE | CAL | INVERT | Pulled out |

36. Check Common-Mode Rejection Ratio

- Test equipment setup is shown in Fig. 6-30.
- Connect the medium-frequency constant-amplitude generator to the INPUT CH 1 and INPUT CH 2 connectors through the five-nanosecond GR cable, 50-ohm in-line termination and the dual-input coupler.
- Set the medium frequency generator for a 3.2-division display at 50 megahertz.

d. Change the following control settings:

- | | |
|------------------------|------------|
| VOLTS/DIV (CH 1 and 2) | 20 mV |
| MODE | ADD |
| INVERT | Pulled out |

Calibration—Type 454/R454

e. CHECK—CRT display for 0.8 division deflection, or less (common-mode rejection ratio 10:1 or better; see Fig. 6-31).

NOTE

This check applies only when the Channel 1 and 2 gain is correctly adjusted as given in step 15. If the common-mode rejection ratio is lower than 10:1, check and readjust the gain. Then recheck this step.

f. Disconnect the dual-input coupler.

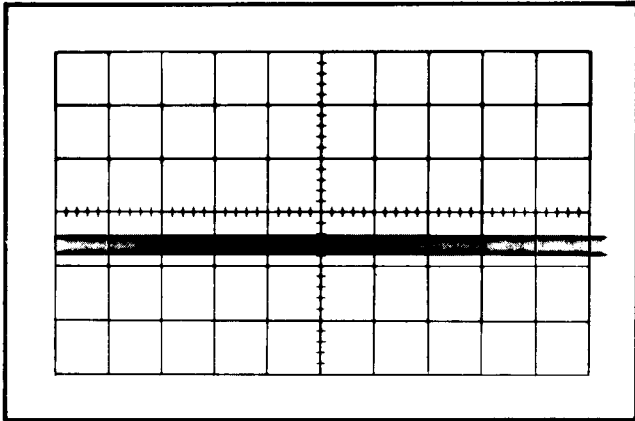

Fig. 6-31. Typical CRT display when checking common-mode rejection ratio.

37. Check Attenuator Isolation Ratio

a. Change the following control settings:

| | |
|---------------------|-----------|
| CH 1 VOLTS/DIV | 1 |
| CH 2 VOLTS/DIV | 5 mV |
| CH 2 Input Coupling | GND |
| MODE | CH 1 |
| INVERT | Pushed in |

b. Connect the medium-frequency constant-amplitude generator to the INPUT CH 1 connector through the five-nanosecond GR cable and the 50-ohm in-line termination.

c. Set the medium-frequency generator for a five-division display at 50 megahertz (use the variable control of the generator, if necessary, to obtain a five-division display).

d. Set the MODE switch to CH 2.

e. CHECK—CRT display for 0.1 division deflection, or less (attenuator isolation ratio 10,000:1 or better; see Fig. 6-32).

f. Change the following control settings:

| | |
|---------------------|------|
| CH 1 VOLTS/DIV | 5 mV |
| CH 2 VOLTS/DIV | 1 |
| CH 1 Input Coupling | GND |
| CH 2 Input Coupling | DC |

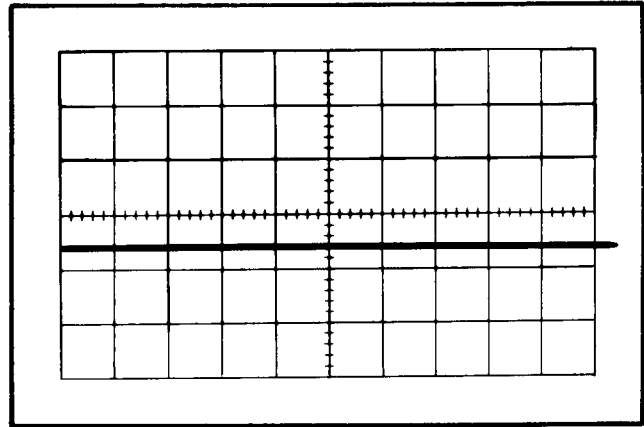

Fig. 6-32. Typical CRT display when checking attenuator isolation ratio and amplifier crosstalk ratio.

g. Connect the medium-frequency generator to the INPUT CH 2 connector through the five-nanosecond GR cable and the 50-ohm in-line termination.

h. Set the medium-frequency generator for a five-division display at 50 megahertz (use the variable control of the generator, if necessary, to obtain a five-division display).

i. Set the MODE switch to CH 1.

j. CHECK—CRT display for 0.1-division deflection or less (attenuator isolation 10,000:1 or better; see Fig. 6-32).

38. Check Amplifier Crosstalk Ratio

a. Change the following control settings:

| | |
|---------------------|------|
| CH 2 VOLTS/DIV | .2 |
| CH 1 Input Coupling | DC |
| MODE | CH 2 |

b. Set the medium-frequency constant-amplitude generator for a two-division display at 50 megahertz.

c. Set the MODE switch to CH 1.

d. Set the CH 1 and CH 2 VOLTS/DIV switches to 20 mV.

e. CHECK—CRT display for 0.2-division deflection or less (amplifier crosstalk ratio 100:1 or better).

f. Connect the medium-frequency generator to the INPUT CH 1 connector through the five-nanosecond GR cable and the 50-ohm in-line termination.

g. Set the CH 1 VOLTS/DIV switch to .2.

h. Set the medium-frequency generator for a two-division display at 50 megahertz.

i. Change the following control settings.

| | |
|----------------|-------|
| CH 1 VOLTS/DIV | 20 mV |
| MODE | CH 2 |

j. CHECK—CRT display for 0.2-division deflection or less (amplifier crosstalk ratio 100:1 or better).

k. Disconnect all test equipment.

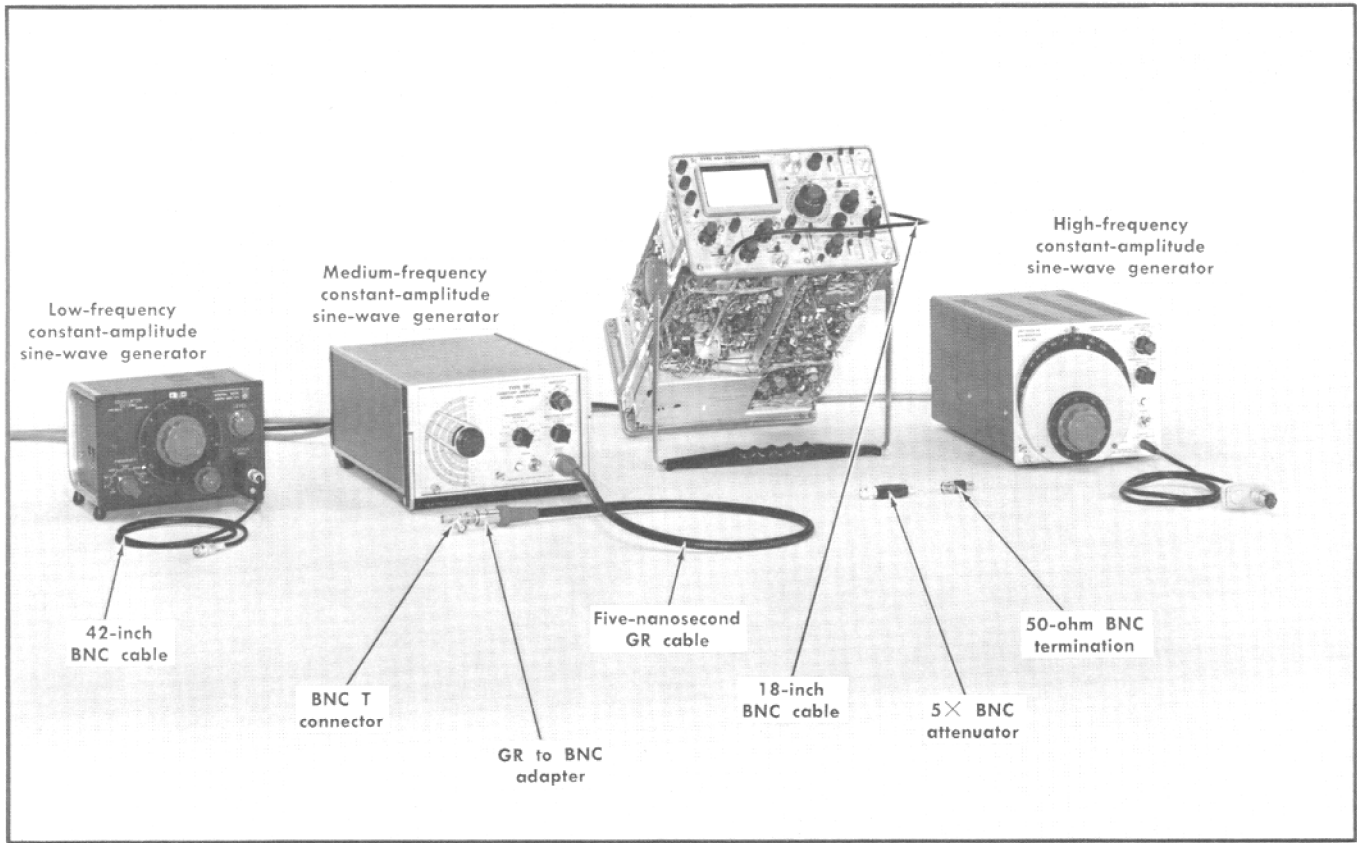

Fig. 6-33. Initial test equipment setup for steps 39 through 50.

- | | | | |
|--|----------------------------|---------------------|-------------------|
| CRT controls | | A VARIABLE | CAL |
| INTENSITY | Midrange | A SWEEP MODE | AUTO TRIG |
| FOCUS | Adjust for focused display | B SWEEP MODE | TRIGGERABLE AFTER |
| SCALE ILLUM | As desired | | DELAY TIME |
| BW-BEAM FINDER | FULL | HORIZ DISPLAY | A |
| | | MAG | OFF |
| Vertical controls (both channels if applicable) | | A SWEEP LENGTH | FULL |
| CH 1 VOLTS/DIV | 20 mV | POSITION | Midrange |
| CH 2 VOLTS/DIV | 10 mV | POWER | ON |
| VARIABLE | CAL | | |
| POSITION | Midrange | Side-panel controls | |
| Input Coupling | GND | B TIME/DIV VARIABLE | CAL |
| MODE | CH 1 | | |
| TRIGGER | NORM | | |
| INVERT | Pushed in | | |
| Triggering controls (both A and B if applicable) | | | |
| LEVEL | 0 | | |
| SLOPE | + | | |
| COUPLING | AC | | |
| SOURCE | INT | | |
| Sweep controls | | | |
| DELAY-TIME MULTIPLIER | 0.10 | | |
| A TIME/DIV | .1 ms | | |
| B TIME/DIV | .1 ms | | |
- 39. Adjust CH 1 OUT DC Level** ❶
- a. Test equipment setup is shown in Fig. 6-33.
 - b. Connect the CH 1 OUT connector to the INPUT CH 2 connector with an 18-inch BNC cable.
 - c. Move the trace to the center horizontal line with the CH 1 POSITION control.
 - d. Set the MODE switch to CH 2.
 - e. Move the trace to the center horizontal line with the CH 2 POSITION control.
 - f. Set the CH 2 Input Coupling switch to DC.

Calibration—Type 454/R454

g. CHECK—CRT display for trace within ± 1.5 division (15 millivolts) of the center horizontal line.

h. ADJUST—CH 1 Output DC Level adjustment, R52 (see Fig. 6-34), to position the trace to the center horizontal line of the graticule.

i. Disconnect the 18-inch BNC cable from between the CH 1 OUT and INPUT CH 2 connectors.

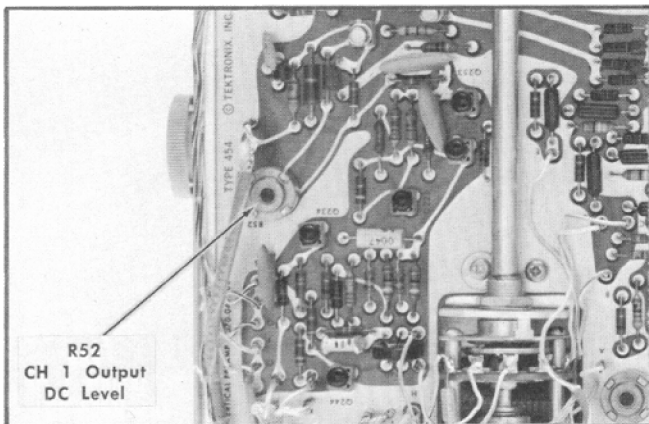

Fig. 6-34. Location of CH 1 output DC level adjustment (Vertical Preamp circuit board).

40. Adjust A and B Trigger Level Centering

a. Change the following control settings:

| | |
|------------------------|------------|
| VOLTS/DIV (CH 1 and 2) | 50 mV |
| CH 1 Input Coupling | DC |
| A and B TIME/DIV | 20 μ s |
| A SWEEP MODE | NORM TRIG |

b. Connect the medium-frequency constant-amplitude generator to the A EXT TRIG INPUT connector through the five-nanosecond GR cable, GR to BNC adapter and BNC T connector. Connect the output of the BNC T connector to the INPUT CH 1 connector through an 18-inch 50-ohm BNC cable and a 50-ohm BNC termination.

c. Set the medium-frequency generator for a 0.3-division display at 50 kilohertz (if necessary, use AUTO TRIG position to obtain 0.3-division display).

d. Be sure the A LEVEL control is set to 0.

e. CHECK—Stable CRT display (see Fig. 6-35A).

f. ADJUST—A Trigger Level Center adjustment, R643 (see Fig. 6-35B), for a stable display.

g. Change the following control settings:

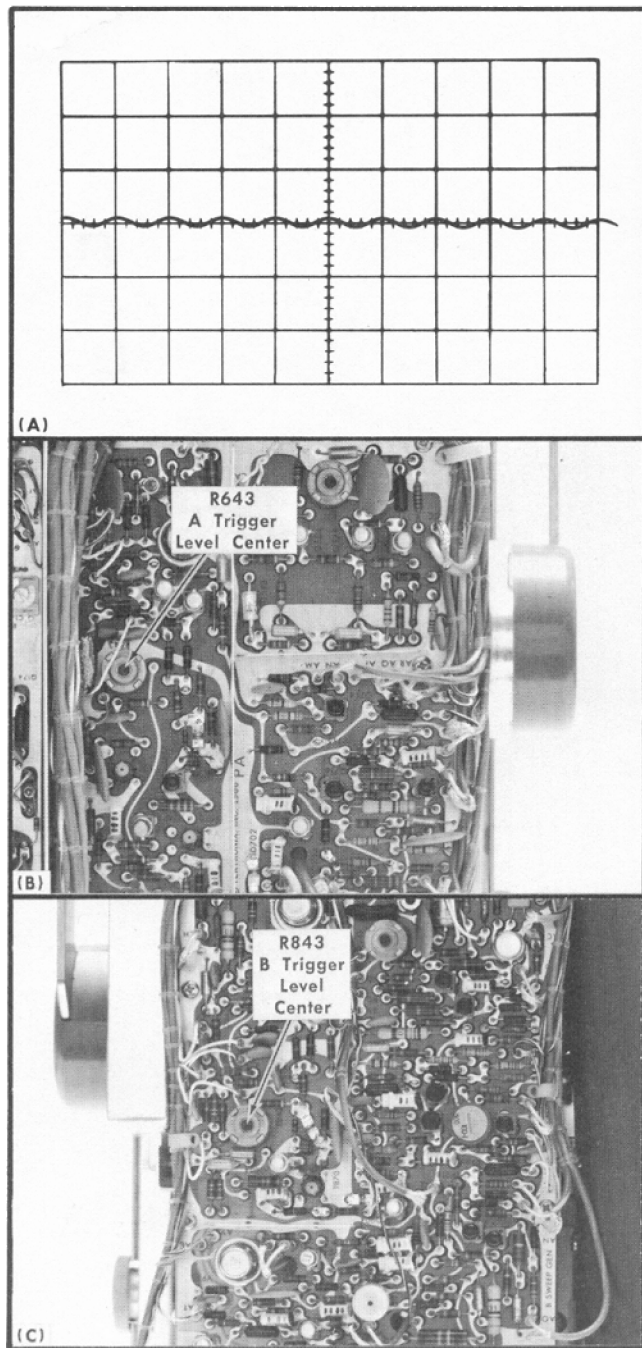

Fig. 6-35. (A) Typical CRT display when checking trigger level centering, (B) location of the A Trigger Level Center adjustment (A Sweep circuit board), (C) location of B Trigger Level Center adjustments (B Sweep circuit board).

| | |
|---------------|-------------------|
| A SWEEP MODE | AUTO TRIG |
| HORIZ DISPLAY | B (DELAYED SWEEP) |

h. Be sure the B LEVEL control is set to 0.

i. CHECK—Stable CRT display (see Fig. 6-35A).

j. ADJUST—B Trigger Level Center adjustment, R843 (see Fig. 6-35C), for a stable display.

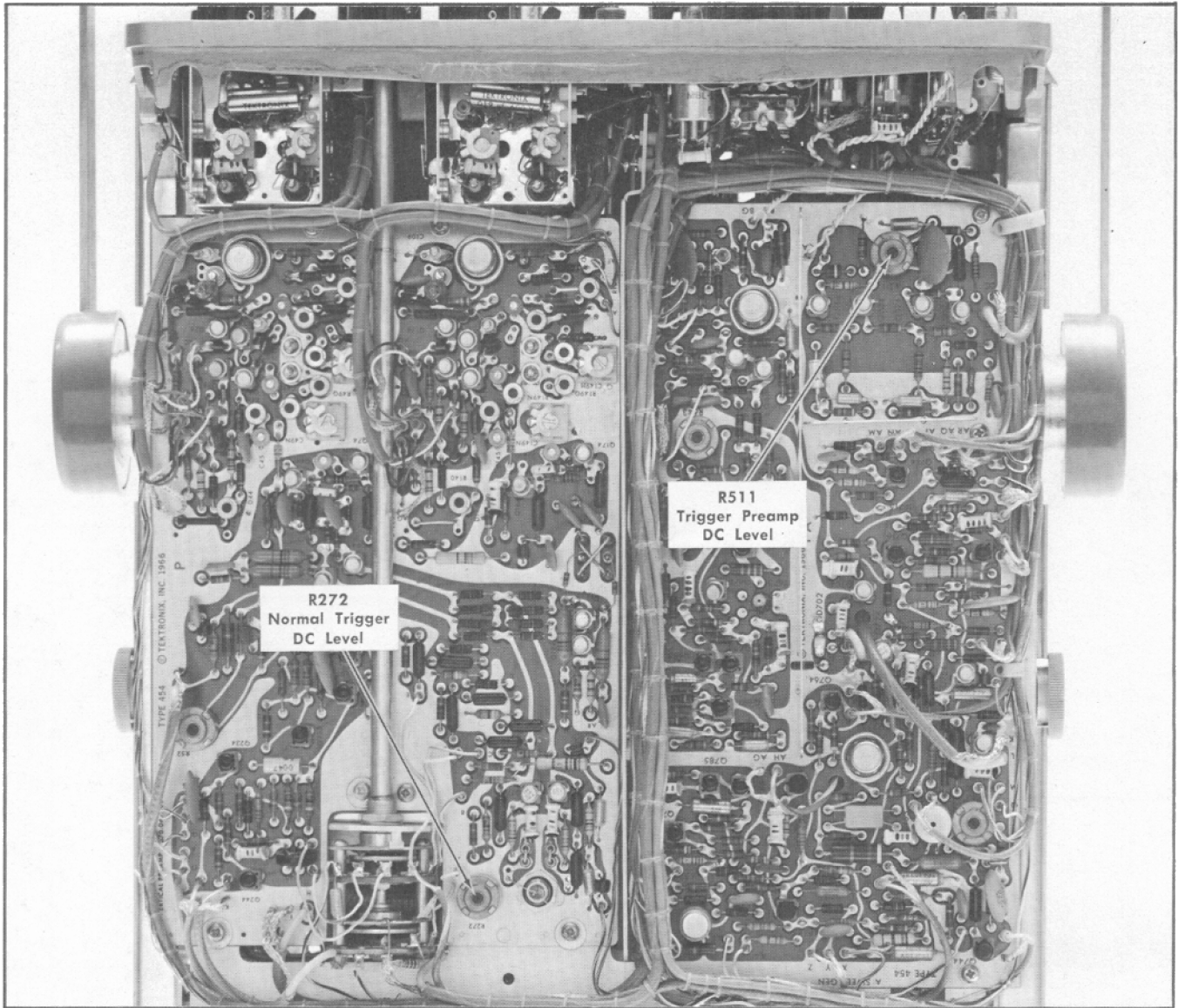

Fig. 6-36. Location of Trigger Preamp DC level adjustment (A Sweep circuit board), and normal trigger DC level adjustment (Vertical Preamp circuit board).

41. Adjust Trigger Preamp DC Level and Normal Trigger DC Level

- a. Change the following control settings:

| | |
|------------|-----------|
| MODE | CH 1 |
| TRIGGER | CH 1 ONLY |
| A COUPLING | DC |
- b. Move the trace to the center horizontal line with the CH 1 POSITION control.
- c. CHECK—Stable CRT display. CH 1 light in both A and B Triggering must be on.
- d. ADJUST—Trigger Preamp DC Level adjustment, R511 (see Fig. 6-36A), for a stable display.
- e. Set the TRIGGER switch to NORM.



f. CHECK—Stable CRT display.

g. ADJUST—Normal Trigger DC Level adjustment, R272 (see Fig. 6-36B), for a stable display.

42. Check A and B 20 Megahertz Triggering Operation

- a. Set the medium-frequency constant-amplitude generator for a 0.3-division display at 20 megahertz.
- b. Set the A and B TIME/DIV switch to .05 μ s.
- c. CHECK—Stable CRT display (see Fig. 6-37A) can be obtained with the B COUPLING switch set to AC, LF REJ and DC (B LEVEL control may be adjusted as necessary to obtain stable display).

Calibration—Type 454/R454

- d. Set the A SWEEP MODE switch to NORM TRIG.
- e. Set the HORIZ DISPLAY switch to A.
- f. CHECK—Stable CRT display (see Fig. 6-37A) can be obtained with the A COUPLING switch set to AC, LF REJ and DC (A LEVEL control may be adjusted as necessary to obtain stable display). The A SWEEP TRIG'D light must be on when the display is stable.
- g. Set both SOURCE switches to EXT.
- h. Set the medium-frequency generator for a 1.5-division display (75 millivolts) at 20 megahertz.
- i. CHECK—Stable CRT display (see Fig. 6-37B) can be obtained with the A COUPLING switch set to AC, LF REJ and DC (A LEVEL control may be adjusted as necessary to obtain stable display).
- j. Disconnect the medium-frequency generator signal from the A EXT TRIG INPUT connector and reconnect it to the B EXT TRIG INPUT connector.
- k. Set the A SOURCE switch to INT and set the A LEVEL control for a triggered display (A TRIG'D light on).
- l. Set the HORIZ DISPLAY switch to B (DELAYED SWEEP).
- m. CHECK—Stable CRT display (see Fig. 6-37B) can be obtained with the B COUPLING switch set to AC, LF REJ and DC (B LEVEL control may be adjusted as necessary to obtain stable display).
- n. Disconnect the medium-frequency generator.

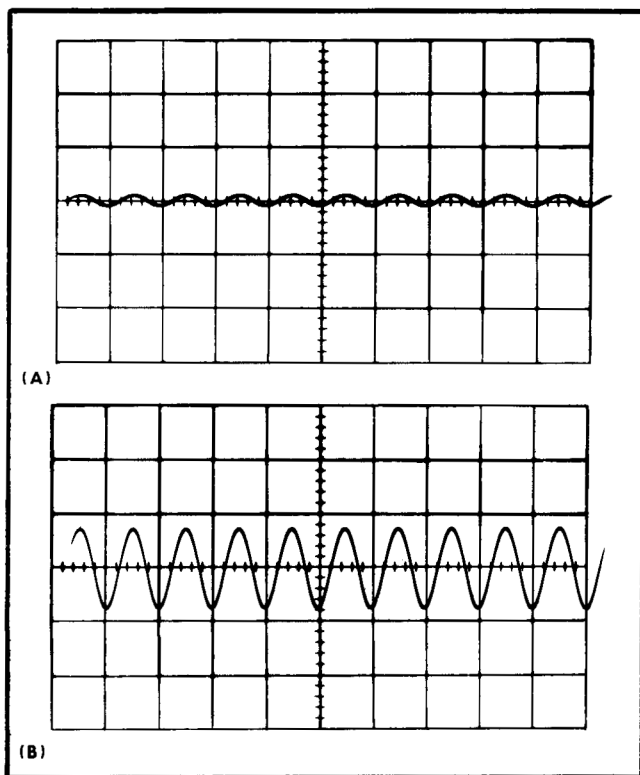

Fig. 6-37. (A) Typical CRT display when checking internal 20 megahertz, (B) typical CRT display when checking external 20 megahertz triggering.

43. Check A and B 150-Megahertz Triggering Operation

- a. Connect the high-frequency constant-amplitude generator (067-0532-00) to the INPUT CH 1 connector through the GR to BNC adapter and the BNC T connector. Connect the output of the BNC T connector to the B EXT TRIG INPUT connector through an 18-inch 50-ohm BNC cable, 5× BNC attenuator and the 50-ohm BNC termination.
- b. Set the CH 1 VOLTS/DIV switch to .5.
- c. Set the high-frequency generator for a 3.75-division display (375 millivolts at B EXT TRIG INPUT connector) at its reference frequency (3 MHz).
- d. Set the MAG switch to ×10.
- e. Without changing the output amplitude, set the high-frequency generator to 150 megahertz.
- f. CHECK—Stable CRT display (see Fig. 6-38A) can be obtained with the B COUPLING switch set to AC, LF REJ and DC (B LEVEL control may be adjusted as necessary to obtain stable display).

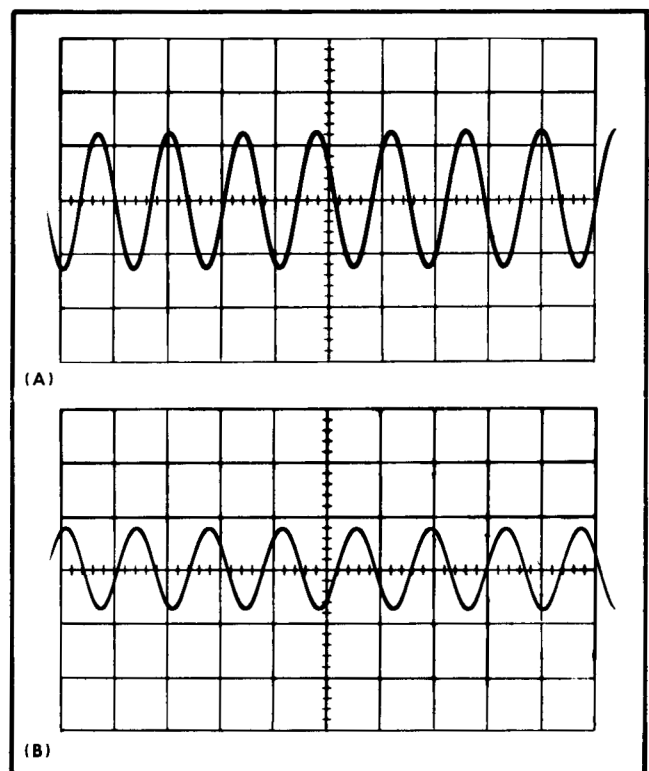

Fig. 6-38. (A) Typical CRT display when checking external 150 megahertz triggering, (B) typical CRT display when checking internal 150 megahertz triggering.

- g. Set the A SOURCE switch to EXT.
- h. Set the HORIZ DISPLAY switch to A.
- i. Disconnect the output of the 50-ohm termination from the B EXT TRIG INPUT connector and reconnect it to the A EXT TRIG INPUT connector.
- j. CHECK—Stable CRT display (see Fig. 6-38A) can be obtained with the A COUPLING switch set to AC, LF REJ and DC (A LEVEL and HF STAB controls may be adjusted as necessary to obtain stable display).

k. Change the following control settings:

CH 1 VOLTS/DIV .1
SOURCE (A and B) INT

l. Set the high-frequency generator for a 1.5-division display at 150 megahertz.

m. CHECK—Stable CRT display (see Fig. 6-38B) can be obtained with the A COUPLING switch set to AC, LF REJ and DC (A LEVEL and HF STAB controls may be adjusted as necessary to obtain stable display). Display jitter should not exceed 0.2 division (1.0 nanoseconds).

n. Set the A SWEEP MODE switch to AUTO TRIG.

o. Set the HORIZ DISPLAY switch to B (DELAYED SWEEP).

p. CHECK—Stable CRT display (see Fig. 6-38B) can be obtained with the B COUPLING switch set to AC, LF REJ and DC (B LEVEL control may be adjusted as necessary to obtain stable display).

q. Disconnect the high-frequency generator.

44. Check A and B Low-Frequency Triggering Operation

a. Connect the low-frequency constant-amplitude generator to the A EXT TRIG INPUT connector through a 50-ohm BNC cable, and the BNC T connector. Connect the output of the BNC T connector to the INPUT CH 1 connector through an 18-inch 50-ohm BNC cable and a 50-ohm BNC termination.

b. Set the CH 1 VOLTS/DIV switch to 50 mV.

c. Set the A and B TIME/DIV switch to 5 ms.

d. Set the low-frequency generator for a 0.3-division display at 60 hertz.

e. CHECK—Stable CRT display (see Fig. 6-39A) can be obtained with the B COUPLING switch set to AC, HF REJ and DC (B LEVEL control may be adjusted as necessary to obtain stable display).

f. Set the A SWEEP MODE switch to NORM TRIG.

g. Set the HORIZ DISPLAY switch to A.

h. CHECK—Stable CRT display (see Fig. 6-39A) can be obtained with the A COUPLING switch set to AC, HF REJ and DC (A LEVEL control may be adjusted as necessary to obtain stable display).

i. Set both SOURCE switches to EXT.

j. Set the low-frequency generator for a 1.5-division display at 60 hertz (75 millivolts).

k. CHECK—Stable CRT display (see Fig. 6-39A) can be obtained with the A COUPLING switch set to AC, HF REJ and DC (A LEVEL control may be adjusted as necessary to obtain stable display).

l. Set the A SWEEP MODE switch to AUTO TRIG.

m. Set the HORIZ DISPLAY switch to B (DELAYED SWEEP).

n. Disconnect the low-frequency generator from the A EXT TRIG INPUT connector and reconnect it to the B EXT TRIG INPUT connector.

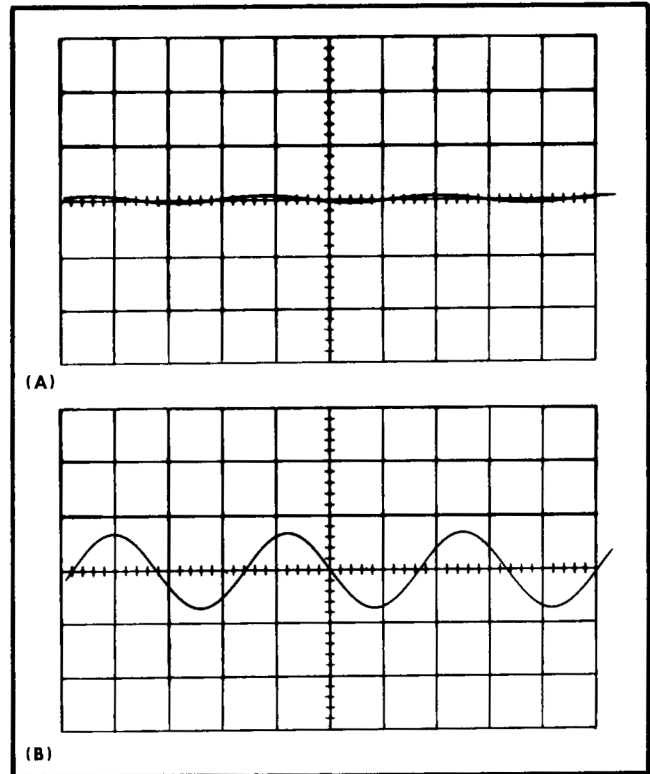

Fig. 6-39. (A) Typical CRT display when checking internal low-frequency triggering at 60 hertz, (B) typical CRT display when checking external low-frequency triggering at 60 hertz.

o. CHECK—Stable CRT display (see Fig. 6-39B) can be obtained with the B COUPLING switch set to AC, HF REJ and DC (B LEVEL control may be adjusted as necessary to obtain stable display).

45. Check A and B High-Frequency Reject Operation

a. Change the following control settings:

COUPLING (A and B) HF REJ
SOURCE (A and B) INT
A and B TIME/DIV 20 μ s

b. Set the low-frequency constant-amplitude generator for a 0.3-division display at 50 kilohertz.

c. CHECK—Stable CRT display (see Fig. 6-40) can be obtained with the B LEVEL control.

d. Without changing the output amplitude, set the low-frequency generator to one megahertz.

e. Set the MAG switch to $\times 10$.

f. CHECK—Stable CRT display cannot be obtained at any setting of the B LEVEL control.

g. Change the following control settings:

A SWEEP MODE NORM TRIG
HORIZ DISPLAY A
MAG OFF

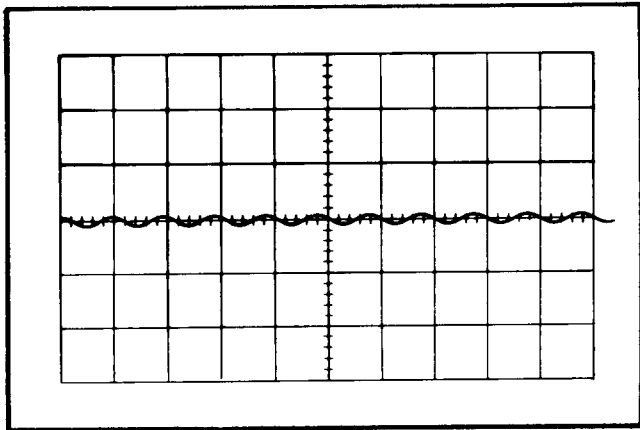

Fig. 6-40. Typical CRT display when checking high-frequency reject operation at 50 kilohertz.

- h. Set the low-frequency generator for a 0.3-division display at 50 kilohertz.
- i. CHECK—Stable CRT display (see Fig. 6-40) can be obtained with the A LEVEL control.
- j. Without changing the output amplitude, set the low-frequency generator to one megahertz.
- k. Set the MAG switch to $\times 10$.
- l. CHECK—Stable CRT display cannot be obtained at any setting of the A LEVEL control.

46. Check A and B Low-Frequency Reject Operation

- a. Set the low-frequency generator for a 0.3-division display at 30 kilohertz.
- b. Change the following control settings:

| | |
|--------------------|--------|
| COUPLING (A and B) | LF REJ |
| A and B TIME/DIV | .1 ms |
| MAG | OFF |
- c. CHECK—Stable CRT display (see Fig. 6-41) can be obtained with the A LEVEL control.
- d. Without changing the output amplitude, set the low-frequency generator to 60 hertz.
- e. Set the A and B TIME/DIV switch to 2 ms.
- f. CHECK—Stable CRT display cannot be obtained at any setting of the A LEVEL control.
- g. Change the following control settings:

| | |
|------------------|-------------------|
| A and B TIME/DIV | .1 ms |
| A SWEEP MODE | AUTO TRIG |
| HORIZ DISPLAY | B (DELAYED SWEEP) |
- h. Set the low-frequency generator for a 0.3-division display at 30 kilohertz.
- i. CHECK—Stable CRT display (see Fig. 6-41) can be obtained with the B LEVEL control.

- j. Without changing the output amplitude, set the low-frequency generator to 60 hertz.
- k. Set the A and B TIME/DIV switch to 2 ms.
- l. CHECK—Stable CRT display cannot be obtained at any setting of the B LEVEL control.

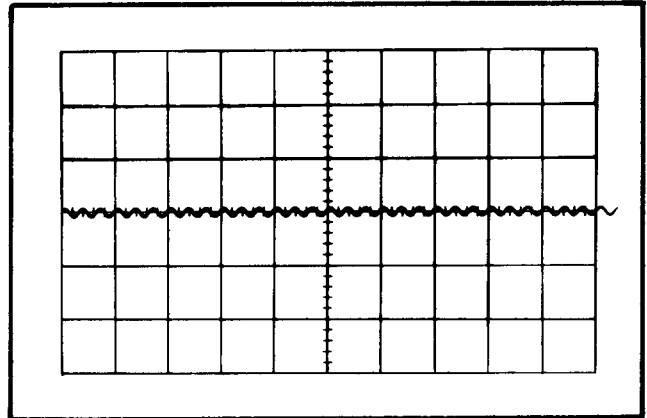

Fig. 6-41. Typical CRT display when checking low-frequency reject operation at 30 kilohertz.

47. Check Single Sweep Operation

- a. Change the following control settings:

| | |
|--------------------|-------|
| COUPLING (A and B) | AC |
| A and B TIME/DIV | .5 ms |
| HORIZ DISPLAY | A |
- b. Set the low-frequency generator for a 0.3-division display at one kilohertz.
- c. Adjust the A LEVEL control for a stable display.
- d. Disconnect the signal from the INPUT CH 1 connector.
- e. Set the A SWEEP MODE switch to SINGLE SWEEP.
- f. Push the RESET button.
- g. CHECK—RESET light must come on when button is pressed and remain on until signal is reapplied.
- h. Reconnect the signal to the INPUT CH 1 connector.
- i. CHECK—A single-sweep display (one sweep only) should be presented. RESET light must go off at the end of the sweep and remain off until the RESET button is pressed again.

48. Check A and B Slope Switch Operation

- a. Set the A SWEEP MODE switch to NORM TRIG.
- b. Set the low-frequency generator for a four-division display at one kilohertz.
- c. CHECK—CRT display starts on the positive slope of the waveform (see Fig. 6-42A).
- d. Set the A SLOPE switch to —.
- e. CHECK—CRT display starts on the negative slope of the waveform (see Fig. 6-42B).

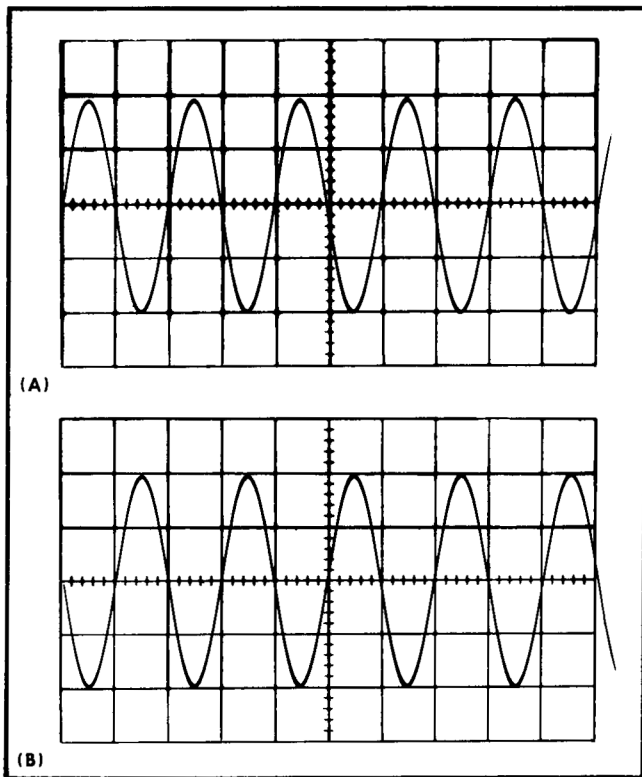

Fig. 6-42. Typical CRT display when checking slope switch operation. (A) SLOPE switch set to +, (B) SLOPE switch set to -.

- f. Set the A SWEEP MODE switch to AUTO TRIG.
- g. Set the HORIZ DISPLAY switch to B (DELAYED SWEEP).
- h. CHECK—CRT display starts on the positive slope of the waveform (see Fig. 6-42A).
- i. Set the B SLOPE switch to -.
- j. CHECK—CRT display starts on the negative slope of the waveform (see Fig. 6-42B).

49. Check A and B Triggering Level Control Range

- a. Connect the low-frequency generator to the B EXT TRIG INPUT connector through a 42-inch BNC cable and the BNC T connector. Connect the output of the BNC T connector to the INPUT CH 1 connector through an 18-inch BNC cable.
- b. Change the following control settings:

| | |
|--------------------|----------|
| CH 1 VOLTS/DIV | 1 |
| COUPLING (A and B) | DC |
| LEVEL (A and B) | Midrange |
| B SOURCE | EXT |
- c. Set the low-frequency generator for a four-division display (four volts peak to peak) at one kilohertz.
- d. CHECK—Rotate the B LEVEL control throughout its range and check that display can be triggered (stable display) at any point along the negative slope of the waveform

(indicates B LEVEL control range of at least + and - two volts). Display is not triggered at either extreme of rotation.

- e. Set the B SLOPE switch to +.
- f. CHECK—Rotate the B LEVEL control throughout its range and check that display can be triggered at any point along the positive slope of the waveform. Display is not triggered at either extreme of rotation.
- g. Set the CH 1 VOLTS/DIV switch to 10.
- h. Set the B SOURCE switch to EXT \div 10.
- i. Set the low-frequency generator for a four-division display (40 volts peak to peak) at one kilohertz.
- j. CHECK—Rotate the B LEVEL control throughout its range and check that display can be triggered at any point along the positive slope of the waveform (indicates B LEVEL control range of at least + and - 20 volts). Display is not triggered at either extreme of rotation.
- k. Set the B SLOPE switch to -.
- l. CHECK—Rotate the B LEVEL control throughout its range and check that display can be triggered at any point along the negative slope of the waveform. Display is not triggered at either extreme of rotation.

m. Change the following control settings:

| | |
|---------------|---------------|
| A SOURCE | EXT \div 10 |
| A SWEEP MODE | NORM TRIG |
| HORIZ DISPLAY | A |

n. Disconnect the low-frequency generator from the B EXT TRIG INPUT connector and reconnect it to the A EXT TRIG INPUT connector.

o. CHECK—Rotate the A LEVEL control throughout its range and check that display can be triggered at any point along the negative slope of the waveform (indicates A LEVEL control range of at least + and - 20 volts). Display is not triggered at either extreme of rotation.

p. Change the following control settings:

| | |
|----------------|-----|
| CH 1 VOLTS/DIV | 1 |
| A SLOPE | + |
| A SOURCE | EXT |

q. Set the low-frequency generator for a four-division display (four volts peak to peak) at one kilohertz.

r. CHECK—Rotate the A LEVEL control throughout its range and check that display can be triggered at any point along the positive slope of the waveform (indicates A LEVEL control range of at least + and - two volts). Display is not triggered at either extreme of rotation.

s. Set the A SLOPE switch to -.

t. CHECK—Rotate the A LEVEL control throughout its range and check that display can be triggered at any point along the negative slope of the waveform. Display is not triggered at either extreme of rotation.

u. Disconnect all test equipment.

50. Check Line Triggering Operation

- a. Connect the 10X probe to the INPUT CH 1 connector.

Calibration—Type 454/R454

b. Change the following control settings:

| | |
|------------------|------|
| CH 1 VOLTS/DIV | 10 |
| SOURCE (A and B) | LINE |
| A and B TIME/DIV | 2 ms |

c. Connect the probe tip to a line-voltage source (such as the rear of the POWER SWITCH).

d. CHECK—Stable CRT display triggered on the correct slope.

e. Set the A SWEEP MODE switch to AUTO TRIG.

f. Set the HORIZ DISPLAY switch to B (DELAYED SWEEP).

g. CHECK—Stable CRT display triggered on the correct slope.

h. Disconnect all test equipment.

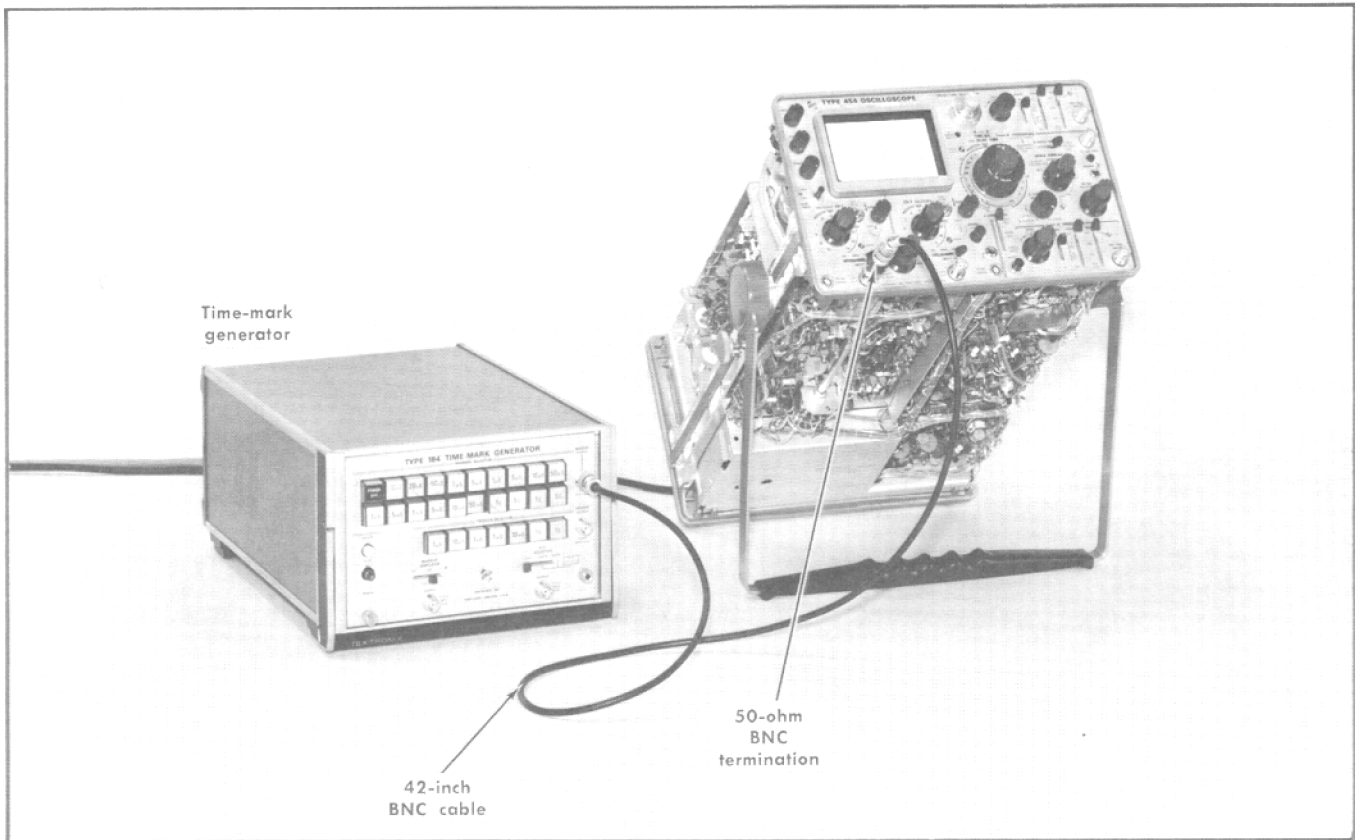

Fig. 6-43. Initial test equipment setup for steps 51 through 71.

CRT controls
 INTENSITY Midrange
 FOCUS Adjusted for focused display
 SCALE ILLUM As desired
 BW-BEAM FINDER FULL

Vertical controls (both channels if applicable)
VOLTS/DIV .2
 VARIABLE CAL
 POSITION Midrange
 Input Coupling DC
 MODE CH 1
 TRIGGER NORM
 INVERT Pushed in

Triggering controls (both A and B if applicable)
LEVEL Stable display
SLOPE +
COUPLING AC
SOURCE INT

Sweep controls
 DELAY-TIME MULTIPLIER 0.10
A TIME/DIV 50 μ s
B TIME/DIV 50 μ s

A VARIABLE
 A SWEEP MODE
B SWEEP MODE
HORIZ DISPLAY
 MAG OFF
 A SWEEP LENGTH FULL
 POSITION Midrange
 POWER ON

Side-panel controls
 B TIME/DIV VARIABLE CAL

51. Check Auto Recovery Time and Operation

- Test equipment setup is shown in Fig. 6-43.
- Connect the time-mark generator to the INPUT CH 1 connector through a 42-inch 50-ohm BNC cable and a 50-ohm BNC termination.
- Set the time-mark generator for 50-millisecond markers.

CAUTION

To prevent permanent damage to the CRT phosphor at slow sweep rates, position the baseline of the marker display below the viewing area.

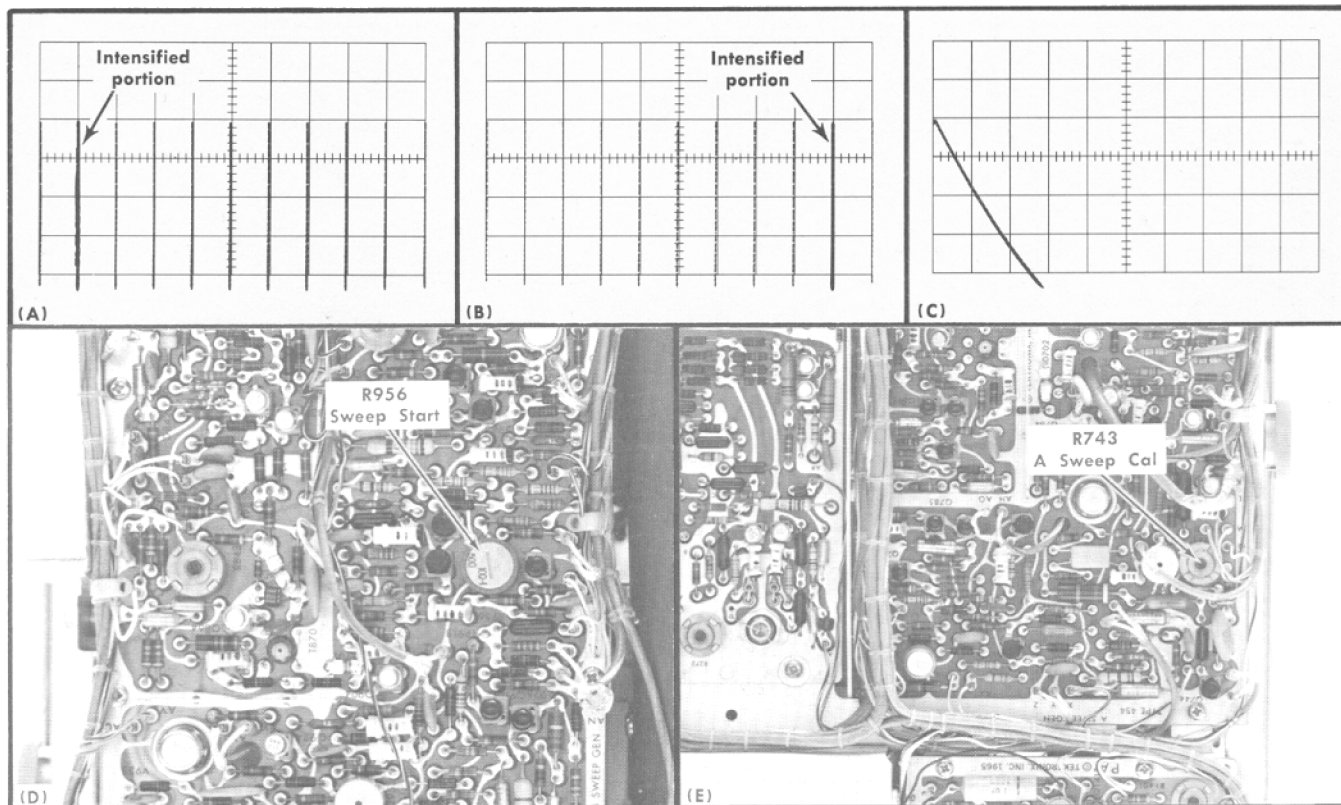

Fig. 6-44. (A) Typical CRT display showing intensified portion correctly located at second marker, (B) typical CRT display showing intensified portion correctly located at tenth marker, (C) typical CRT display showing correct final adjustment of Sweep Start and A Sweep Cal adjustments, (D) location of Sweep Start adjustment (B Sweep circuit board), (E) location of A Sweep Cal adjustment (A Sweep circuit board).

- d. CHECK—Stable display can be obtained with the A LEVEL control. Marker must be at the start of the sweep.
- e. Set the time-mark generator for 0.1-second markers.
- f. CHECK—Sweep free runs and stable display cannot be obtained. If stable display is obtained, marker must not be at the start of the sweep.

52. Adjust Sweep Start and A Sweep Calibration ❶

- a. Change the following control settings:

| | |
|---------------|------------------|
| A TIME/DIV | 1 ms |
| B TIME/DIV | 5 μ s |
| HORIZ DISPLAY | A INTEN DURING B |
- b. Turn the DELAY-TIME MULTIPLIER dial fully counterclockwise.
- c. CHECK—DELAY-TIME MULTIPLIER dial setting 0.10.
- d. ADJUST—If the DELAY-TIME MULTIPLIER dial is not at 0.10 when fully counterclockwise, loosen the set screw and reposition the dial to 0.10.
- e. Repeat parts b through d until the DELAY-TIME MULTIPLIER dial is correctly positioned at 0.10.
- f. Set the time-mark generator for one-millisecond markers.
- g. Set the DELAY-TIME MULTIPLIER dial to 1.00.
- h. CHECK—Intensified portion of display starts at second marker (see Fig. 6-44A).
- i. ADJUST—Sweep Start adjustment, R956 (see Fig. 6-44D), so intensified portion starts at second marker (preliminary adjustment).
- j. Set DELAY-TIME MULTIPLIER dial to 9.00.
- k. CHECK—Intensified portion of display starts at tenth marker (see Fig. 6-44B).
- l. ADJUST—A Sweep Cal adjustment, R743 (see Fig. 6-44E), so intensified portion starts at tenth marker (preliminary adjustment).
- m. Set the HORIZ DISPLAY switch to B (DELAYED SWEEP).
- n. Set the DELAY-TIME MULTIPLIER dial to 1.00.
- o. CHECK—Displayed pulse starts at the beginning of the sweep (see Fig. 6-44C).
- p. ADJUST—Sweep Start adjustment, R956 (see Fig. 6-44D), so displayed pulse starts at the beginning of the sweep.
- q. Set DELAY-TIME MULTIPLIER dial to 9.00.
- r. CHECK—Displayed pulse starts at the beginning of the sweep (see Fig. 6-44C).
- s. ADJUST—A Sweep Cal adjustment, R743 (see Fig. 6-44E), so displayed pulse starts at the beginning of the sweep.

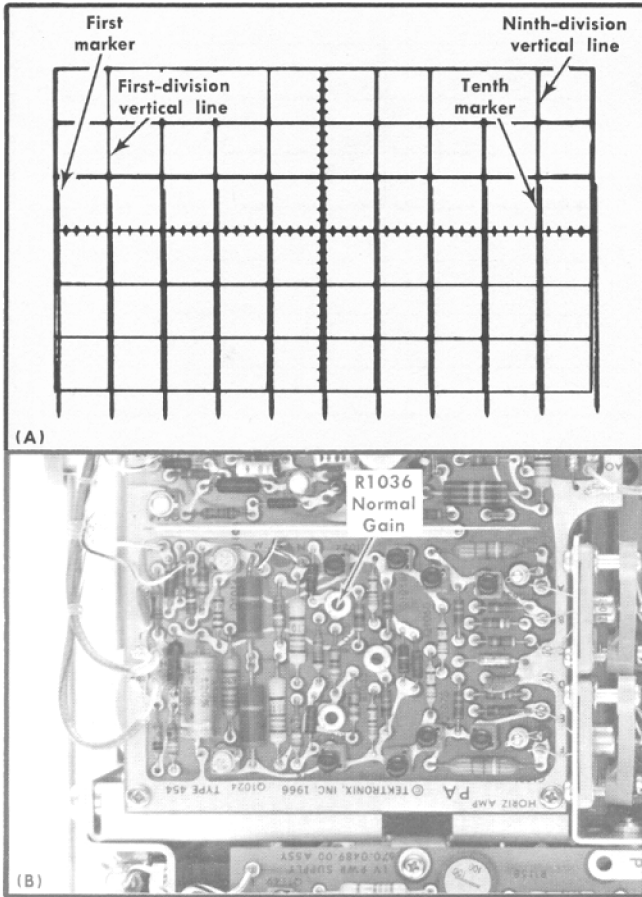

Fig. 6-45. (A) Typical CRT display showing correct normal gain, (B) location of Normal Gain adjustment (B Sweep circuit board).

t. Recheck parts n through s and readjust if necessary.

53. Adjust Normal Gain



- a. Set the HORIZ DISPLAY switch to A.
- b. CHECK—CRT display for one marker each division between the first- and ninth-division vertical lines (see Fig. 6-45A).

NOTE

Unless otherwise noted, use the middle eight horizontal divisions when checking or adjusting timing.

- c. ADJUST—Normal Gain adjustment, R1036 (see Fig. 6-45B), for one marker each division. The second and tenth markers must coincide exactly with their respective graticule lines (reposition the display slightly with the horizontal POSITION control if necessary).
- d. Position the second marker to the first-division vertical line.
- e. CHECK—Fourth marker within 0.1 division (within 5%) of the third-division vertical line.

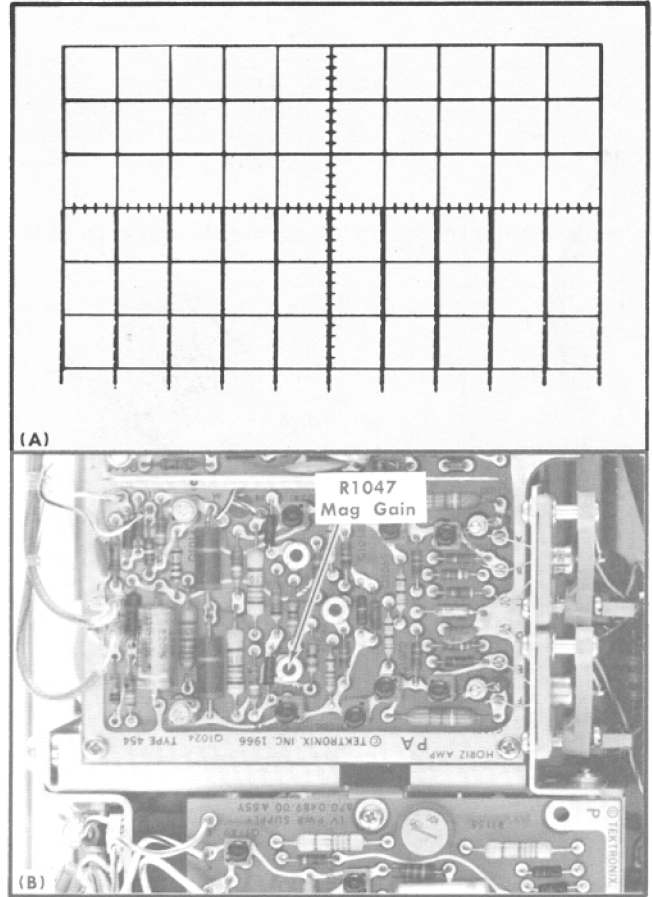

Fig. 6-46. (A) Typical CRT display showing correct magnified gain, (B) location of Mag Gain adjustment (B Sweep circuit board).

- f. Position the third marker to the second-division vertical line.
- g. CHECK—Fifth marker within 0.1 division (within 5%) of the fourth-division vertical line.
- h. Continue this check for each two-division portion of the sweep within the center eight divisions of the graticule.
- i. INTERACTION—Check steps 54-71.

54. Adjust Magnified Gain



- a. Set the time-mark generator for 0.1-millisecond markers.
- b. Set the MAG switch to $\times 10$.
- c. CHECK—CRT display for one marker each division between the first- and ninth-division vertical lines (see Fig. 6-46A).
- d. ADJUST—Mag Gain adjustment, R1047 (see Fig. 6-46B), for one marker each division. The second and tenth markers must coincide exactly with their respective graticule lines (reposition the display slightly with the horizontal FINE control if necessary).

Calibration—Type 454/R454

e. Position the first eight-division portion of the total magnified sweep onto the viewing area.

f. CHECK—One marker each division between the first- and ninth-division vertical lines; marker at ninth-division vertical line must be within 0.32 division (within 4%) of the line when the marker at the first-division vertical line is positioned exactly.

g. Repeat this check for each eight-division portion of the total magnified sweep length.

h. Set the horizontal POSITION and FINE controls to mid-range.

i. Position a marker to the first-division vertical line.

j. CHECK—Marker within 0.1 division (within 5%) of the third-division vertical line.

k. Position the marker nearest the second-division vertical line to that line.

l. CHECK—Marker within 0.1 division (within 5%) of the fourth-division vertical line.

m. Continue this check for each two-division portion of the displayed sweep within the center eight divisions of the graticule.

n. INTERACTION—Check steps 55, 64, 66 and 68.

55. Adjust Magnifier Register



a. Set the time-mark generator for five-millisecond markers.

b. Position the middle marker (three markers on total magnified sweep) to the center vertical line (see Fig. 6-47A).

c. Set the MAG switch to OFF.

d. CHECK—Middle marker should remain at the center vertical line (see Fig. 6-47B).

e. ADJUST—Mag Register adjustment, R1053 (see Fig. 6-47C), to position the middle marker to the center vertical line.

f. Set the MAG switch to $\times 10$.

g. Repeat parts b through e until no shift occurs when the MAG switch is set to OFF.

56. Adjust B Sweep Calibration



a. Change the following control settings:

| | |
|-----------------------|---------------------------------|
| DELAY-TIME MULTIPLIER | 0.10 |
| B TIME/DIV | .1 ms |
| B SWEEP MODE | TRIGGERABLE AFTER DELAY TIME |
| HORIZ DISPLAY | B (DELAYED SWEEP) |
| MAG | OFF |

b. Set the time-mark generator for one-millisecond markers.

c. Set the B LEVEL control for a stable display.

d. CHECK—CRT display for one marker each division between the first- and ninth-division vertical lines (see Fig. 6-48A).

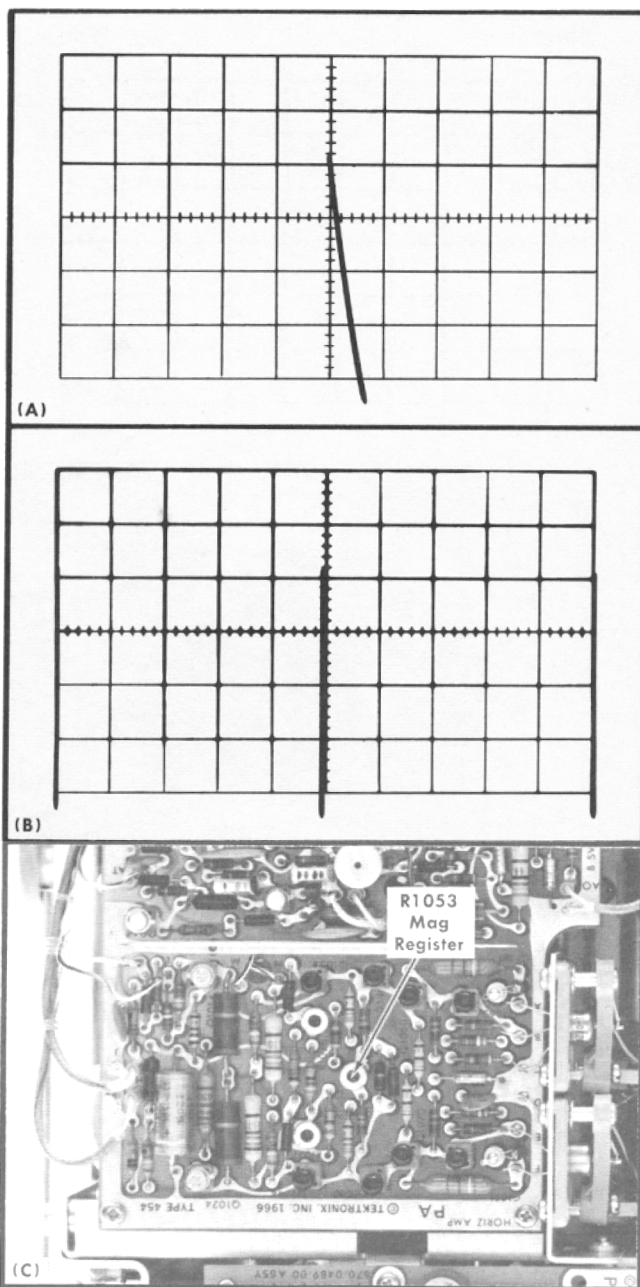

Fig. 6-47. Typical CRT display showing correct magnifier registration. (A) MAG switch set to $\times 10$, (B) MAG switch set to OFF. (C) Location of Mag Register adjustment (B Sweep circuit board).

e. ADJUST—B Sweep Cal adjustment, R943 (see Fig. 6-48B), for one marker each division.

f. position the second marker to the first-division vertical line.

g. CHECK—Fourth marker within 0.1 division (within 5%) of the third-division vertical line.

h. Position the third marker to the second-division vertical line.

i. CHECK—Fifth marker within 0.1 division (within 5%) of the fourth-division vertical line.

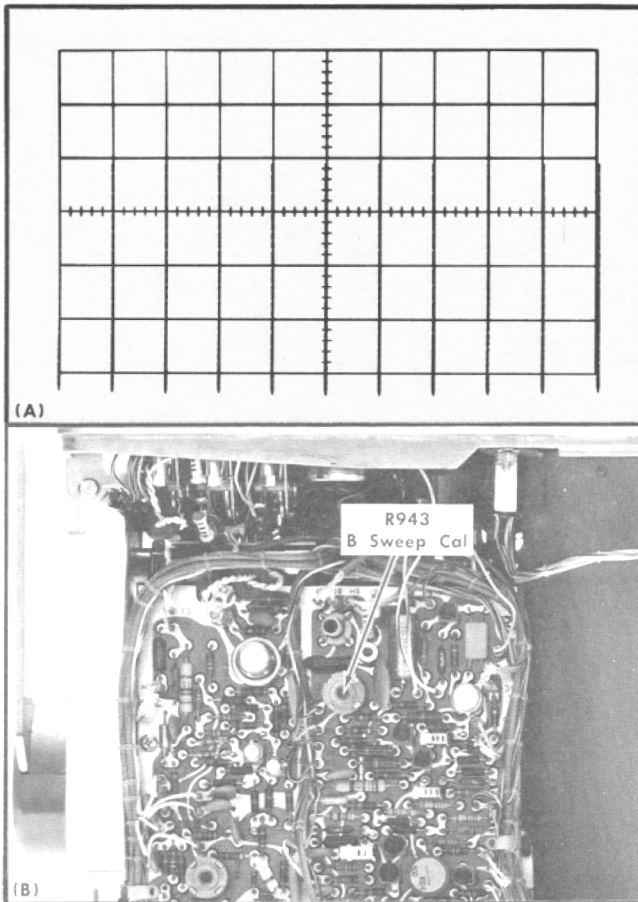

Fig. 6-48. (A) Typical CRT display showing correct B Sweep calibration, (B) location of the B Sweep Cal adjustment (B Sweep circuit board).

- j. Continue this check for each two-division portion of the sweep within the center eight divisions of the graticule.
- k. INTERACTION—Check step 67.

57. Check B Sweep Length

- a. Change the following control settings:

| | |
|-----------------------|------|
| DELAY-TIME MULTIPLIER | 0.10 |
| A TIME/DIV | 2 ms |
| B TIME/DIV | 1 ms |
- b. Set the time-mark generator for 1- and 0.1-millisecond markers.
- c. Adjust the B LEVEL control for a stable display.
- d. Move the eleventh large marker to the center vertical line with the horizontal POSITION control (see Fig. 6-49).
- e. CHECK—B Sweep length must be between 10.5 and 11.5 divisions as shown by 0.5 to 1.5 divisions of display to the right of the center vertical line (see Fig. 6-49). Large markers indicate divisions and small markers indicate 0.1 division.

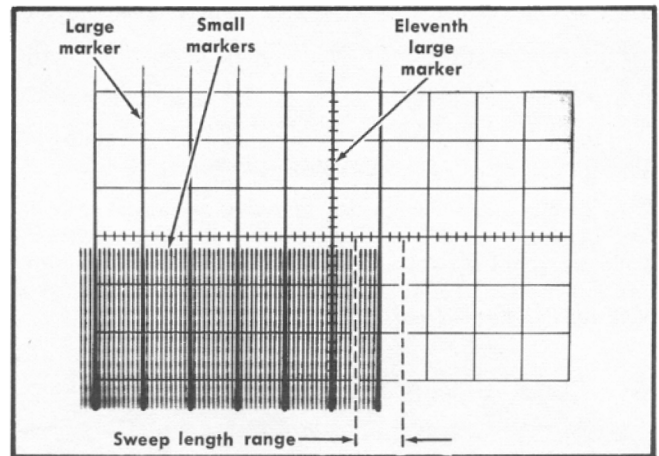

Fig. 6-49. Typical CRT display when checking A and B sweep length.

58. Check A Sweep Length

- a. Set the HORIZ DISPLAY switch to A.
- b. Set the A TIME/DIV switch to 1 ms.
- c. Adjust the A LEVEL control for a stable display.
- d. Move the eleventh marker to the center vertical line with the horizontal POSITION control (see Fig. 6-49).
- e. CHECK—A Sweep length must be between 10.5 and 11.5 divisions as shown by 0.5 to 1.5 divisions of display to the right of the center vertical line (see Fig. 6-49).
- f. Reposition the first marker to the left graticule line.
- g. Turn the A SWEEP LENGTH control to 4 DIV (not in B ENDS A detent).
- h. CHECK—A Sweep length must be four divisions or less.

59. Check B Ends A Operation

- a. Change the following control settings:

| | |
|----------------|---------------------------|
| B TIME/DIV | .1 ms |
| B SWEEP MODE | B STARTS AFTER DELAY TIME |
| HORIZ DISPLAY | A INTEN DURING B |
| A SWEEP LENGTH | B ENDS A |
- b. Rotate the DELAY-TIME MULTIPLIER dial throughout its range.
- c. CHECK—CRT display ends after the intensified portion at all DELAY-TIME MULTIPLIER dial settings.

60. Check A Variable Control Range

- a. Change the following control settings:

| | |
|-----------------------|------|
| DELAY-TIME MULTIPLIER | 0.10 |
| B TIME/DIV | 1 ms |
| HORIZ DISPLAY | A |
| A SWEEP LENGTH | FULL |

Calibration—Type 454/R454

- b. Set the time-mark generator for 10-millisecond markers.
- c. Set the A LEVEL control for a stable display.
- d. Position the markers to the far left and right graticule lines with the horizontal POSITION control.
- e. Turn the A VARIABLE control fully counterclockwise.
- f. CHECK—CRT display for four-division maximum spacing between markers (indicates adequate range for continuously variable sweep rates between the calibrated steps; see Fig. 6-50). UNCAL A OR B light must be on when A VARIABLE control is not in CAL position.

61. Check B Variable Control Range

- a. Change the following control settings:

| | |
|---------------|------------------------------|
| A TIME/DIV | 5 ms |
| B TIME/DIV | 1 ms |
| A VARIABLE | CAL |
| B SWEEP MODE | TRIGGERABLE AFTER DELAY TIME |
| HORIZ DISPLAY | B (DELAYED SWEEP) |
- b. Position the markers to the far left and right vertical lines of the graticule with the horizontal POSITION control.
- c. Turn the B TIME/DIV VARIABLE control fully counterclockwise.
- d. CHECK—CRT display for four-division maximum spacing between markers (indicates adequate range for continuously variable sweep rate between the calibrated steps; see Fig. 6-50). UNCAL A OR B light must be on when the B TIME/DIV VARIABLE control is not in CAL position.

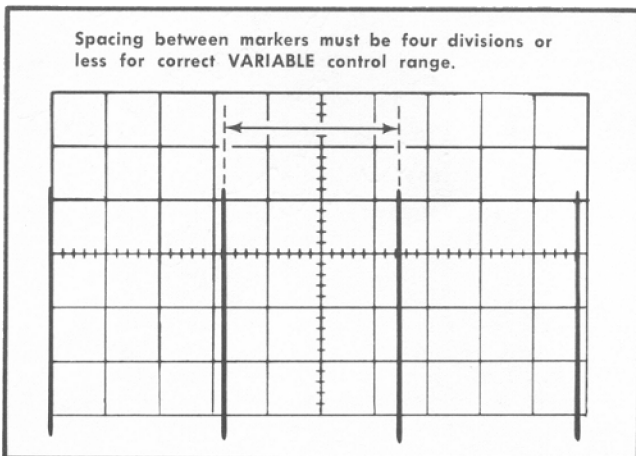

Fig. 6-50. Typical CRT display when checking A and B VARIABLE control range.

62. Adjust A and B One Microsecond Timing ❶

- a. Change the following control settings:

| | |
|---------------------|-----------|
| A and B TIME/DIV | 1 μ s |
| HORIZ DISPLAY | A |
| B TIME/DIV VARIABLE | CAL |

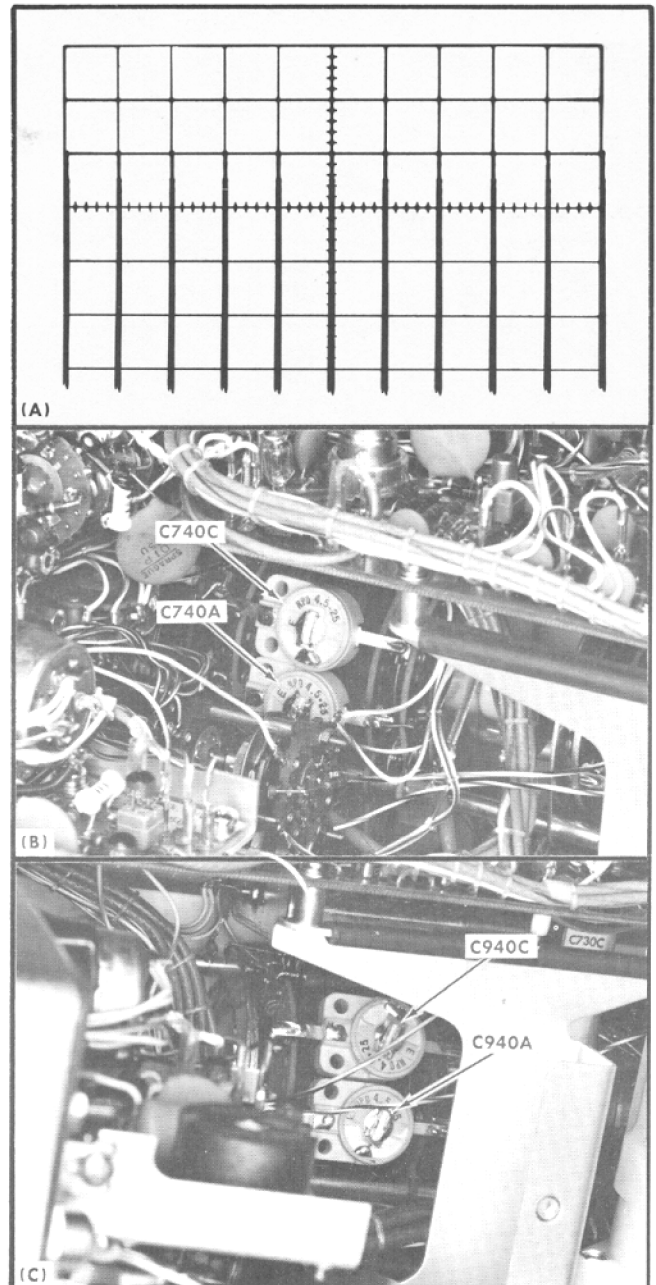

Fig. 6-51. (A) Typical CRT display showing correct one-microsecond timing, (B) location of C740A and C740C (behind swing-out side panel), (C) location of C940A and C940C (behind swing-out side panel).

- b. Set the time-mark generator for one-microsecond markers.
- c. CHECK—CRT display for one marker each division between the first- and ninth-division vertical lines (see Fig. 6-51A).
- d. ADJUST—C740C (see Fig. 6-51B) for one marker each division.
- e. Set the HORIZ DISPLAY switch to B (DELAYED SWEEP).

- f. CHECK—CRT display for one marker each division between the first- and ninth-division vertical lines (see Fig. 6-51A).
- g. ADJUST—C940C (see Fig. 6-51C) for one marker each division.

63. Adjust A and B 0.5 Microsecond Timing ①

- a. Set the A and B TIME/DIV switches to $.5 \mu s$.
- b. Set the time-mark generator for 0.5-microsecond markers.
- c. CHECK—CRT display for one marker each division between the first- and ninth-division vertical lines (see Fig. 6-52).
- d. ADJUST—C940A (see Fig. 6-51C) for one marker each division.
- e. Set the HORIZ DISPLAY switch to A.
- f. CHECK—CRT display for one marker each division between the first- and ninth-division graticule lines (see Fig. 6-52).
- g. ADJUST—C740A (see Fig. 6-51B) for one marker each division.

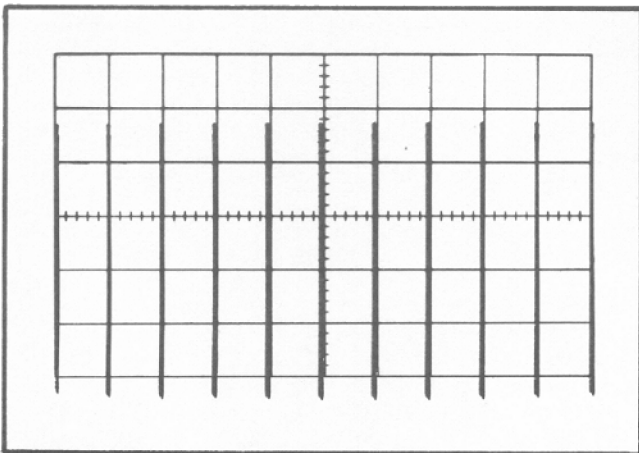

Fig. 6-52. Typical CRT display showing correct 0.5-microsecond timing.

64. Adjust High-Speed Linearity ①

- a. Change the following control settings:

| | |
|----------------|-------------|
| CH 1 VOLTS/DIV | 50 mV |
| A TIME/DIV | $.05 \mu s$ |
- b. Set the time-mark generator for five-nanosecond markers.
- c. Position the display horizontally so the sweep starts at the left edge of the graticule.
- d. Set the CH 1 POSITION control to move the top of the display to the center horizontal line.
- e. Set the MAG switch to $\times 10$.
- f. CHECK—CRT display for optimum linearity over the center eight divisions of the graticule (see Fig. 6-53A).

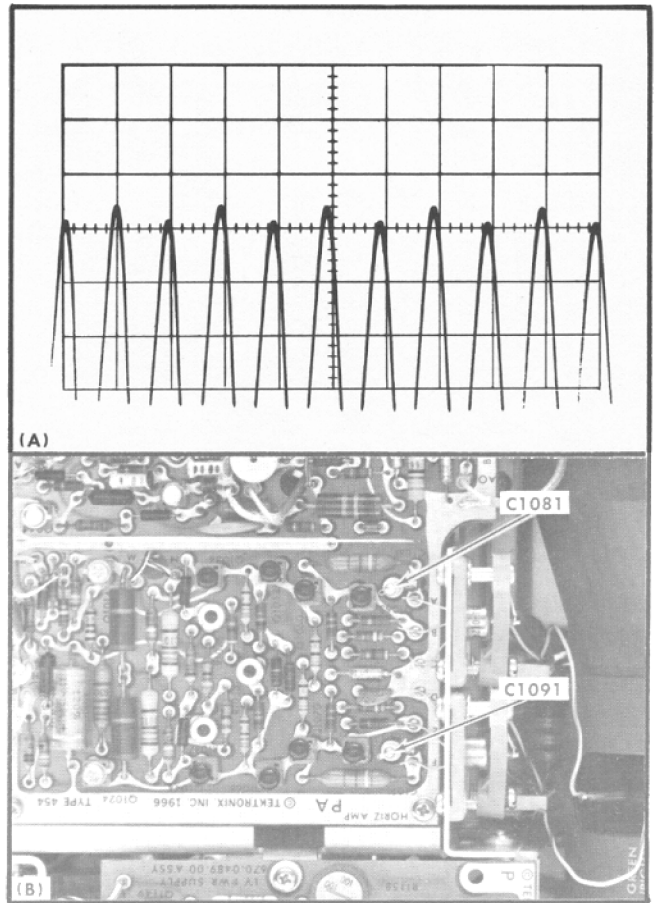

Fig. 6-53. (A) Typical CRT display showing correct high speed linearity, (B) location of C1081 and C1091 (B Sweep circuit board).

- g. ADJUST—C1081 and C1091 (see Fig. 6-53B) for optimum linearity over the center eight divisions of the graticule.
- h. Set the A TIME/DIV switch to $.1 \mu s/DIV$.
- i. CHECK—CRT display for optimum linearity over the center eight divisions. If the first division shows excessive non-linearity, compromise the setting of C1081 and C1091 at five and 10 nanoseconds/division.

65. Check A Sweep Timing Accuracy

- a. Change the following control settings:

| | |
|----------------|-----|
| CH 1 VOLTS/DIV | .2 |
| MAG | OFF |
- b. CHECK—Using the A TIME/DIV switch and time-mark generator settings given in Table 6-6, check A sweep timing within 0.24 division, over the middle eight divisions of the display (within 3%).

CAUTION

To prevent possible burning of the CRT phosphor at slow sweep rates, position the baseline of the marker display below the viewing area.

TABLE 6-6
A and B Timing Accuracy

| A and B TIME/DIV Switch Setting | Time-Mark Generator Output | CRT Display (markers/division) |
|---------------------------------|----------------------------|--------------------------------|
| .05 μ s | 50 nanosecond | 1 |
| .1 μ s | 0.1 microsecond | 1 |
| .2 μ s | 0.1 microsecond | 2 |
| .5 μ s | 0.5 microsecond | 1 |
| 1 μ s | 1 microsecond | 1 |
| 2 μ s | 1 microsecond | 2 |
| 5 μ s | 5 microsecond | 1 |
| 10 μ s | 10 microsecond | 1 |
| 20 μ s | 10 microsecond | 2 |
| 50 μ s | 50 microsecond | 1 |
| .1 ms | 0.1 millisecond | 1 |
| .2 ms | 0.1 millisecond | 2 |
| .5 ms | 0.5 millisecond | 1 |
| 1 ms | 1 millisecond | 1 |
| 2 ms | 1 millisecond | 2 |
| 5 ms | 5 millisecond | 1 |
| 10 ms | 10 millisecond | 1 |
| 20 ms | 10 millisecond | 2 |
| 50 ms | 50 millisecond | 1 |
| .1 s | 0.1 second | 1 |
| .2 s | 0.1 second | 2 |
| .5 s | 0.1 second | 1 |
| A Sweep Only | | |
| 1 s | 1 second | 1 |
| 2 s | 1 second | 2 |
| 5 s | 5 second | 1 |

66. Check A Magnified Sweep Accuracy

- a. Set the MAG switch to $\times 10$.
- b. CHECK—Using the A TIME/DIV switch and time-mark generator settings given in Table 6-7, check A magnified sweep timing within 0.32 divisions over the middle eight divisions of the magnified display (within 4%). Note the portions of the total magnified sweep length to be excluded from the measurement. Magnifier light must be on.

NOTE

Change the CH 1 VOLTS/DIV switch to 50 mV and use the HF STAB control to obtain a stable display of the five-nanosecond markers.

67. Check B Sweep Timing Accuracy

- a. Set the MAG switch to OFF.
- b. Set the HORIZ DISPLAY switch to B (DELAYED SWEEP).
- c. CHECK—Using the A and B TIME/DIV switch and time-mark generator settings given in Table 6-6, check B sweep timing within 0.24 division over the middle eight division of the display (within 3%).

68. Check B Magnified Sweep Accuracy

- a. Set the MAG switch to $\times 10$.
- b. CHECK—Using the A and B TIME/DIV switch and time-mark generator settings given in Table 6-7, check B magnified sweep timing within 0.32 division over the middle eight divisions of the magnified display (within 4%). Note the portions of the total magnified sweep length to be excluded from the measurement.

NOTE

Change the CH 1 VOLTS/DIV switch to 50 mV to display the five-nanosecond markers.

69. Check Delay-Time Accuracy

- a. Set the MAG switch to OFF.
- b. Set the B SWEEP MODE switch to B STARTS AFTER DELAY TIME.
- c. CHECK—Using the A TIME/DIV switch, B TIME/DIV switch and time-mark generator settings given in Table 6-8, check delayed sweep accuracy within the given tolerance. First set the DELAY-TIME MULTIPLIER dial to 1.00 and rotate the dial until the sweep starts at the top of the second marker (see Fig. 6-54). Note the dial reading and then set the dial to 9.00 and rotate until the sweep starts at the top of the tenth marker. DELAY-TIME MULTIPLIER dial setting must be 8.00 divisions higher, + or - the allowable error given in Table 6-8.

NOTE

Sweep will start at top of third marker at 1.00, and nineteenth marker at 9.00 for sweep rates which are multiples of 2 (e.g., 2 μ s, 20 μ s, .2 ms, etc.). If in doubt as to the correct setting of the DELAY-TIME MULTIPLIER dial, set the HORIZ DISPLAY switch to A INTEN DURING B and check which marker is intensified.

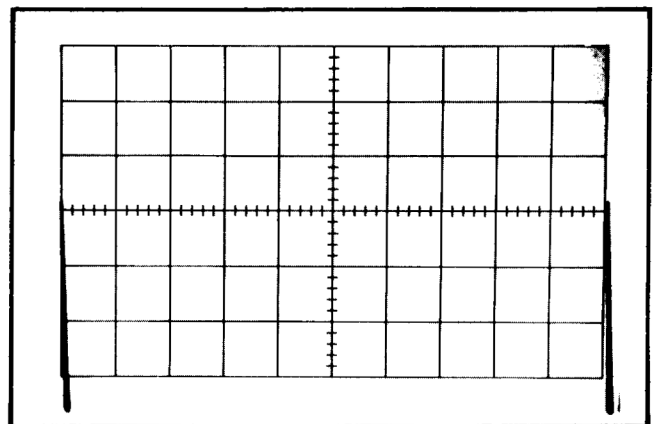

Fig. 6-54. Typical CRT display when checking delayed-sweep accuracy.

TABLE 6-7
A and B Magnified Accuracy

| A and B TIME/DIV Switch Setting | Time-Mark Generator Output | CRT Display (markers/division) | Portions of total magnified sweep length to exclude from measurement |
|---------------------------------|----------------------------|--------------------------------|--|
| .05 μ s | 5 nanosecond | 1 | First 12 and last six divisions. |
| .1 μ s | 10 nanosecond | 1 | First six and last three divisions. |
| .2 μ s | 10 nanosecond | 2 | First three and last 1.5 divisions. |
| .5 μ s | 50 nanosecond | 1 | |
| 1 μ s | 0.1 microsecond | 1 | |
| 2 μ s | 0.1 microsecond | 2 | |
| 5 μ s | 0.5 microsecond | 1 | |
| 10 μ s | 1 microsecond | 1 | |
| 20 μ s | 1 microsecond | 2 | |
| 50 μ s | 5 microsecond | 1 | |
| .1 ms | 10 microsecond | 1 | |
| .2 ms | 10 microsecond | 2 | |
| .5 ms | 50 microsecond | 1 | |
| 1 ms | 0.1 millisecond | 1 | |
| 2 ms | 0.1 millisecond | 2 | |
| 5 ms | 0.5 millisecond | 1 | |
| 10 ms | 1 millisecond | 1 | |
| 20 ms | 1 millisecond | 2 | |
| 50 ms | 5 millisecond | 1 | |
| .1 s | 10 millisecond | 1 | |
| .2 s | 10 millisecond | 2 | |
| .5 s | 50 millisecond | 1 | |
| 1 s | 0.1 second | 1 | |
| 2 s | 0.1 second | 2 | |
| 5 s | 0.5 second | 1 | |

70. Check Delay-Time Multiplier Incremental Linearity

a. Change the following control settings:

DELAY-TIME MULTIPLIER 9.00
A TIME/DIV 1 ms
B TIME/DIV 5 μ s

b. Set the time-mark generator for one-millisecond markers.

c. Rotate the dial as necessary to position the start of the pulse to the beginning of the sweep (see Fig. 6-55).

d. CHECK—Deviation of dial reading from 9.00 should be within two minor dial divisions ($\pm 0.2\%$).

NOTE

A sweep must be correctly calibrated to check this step to the given accuracy.

e. Repeat check at each major dial division between 9.00 and 1.00.

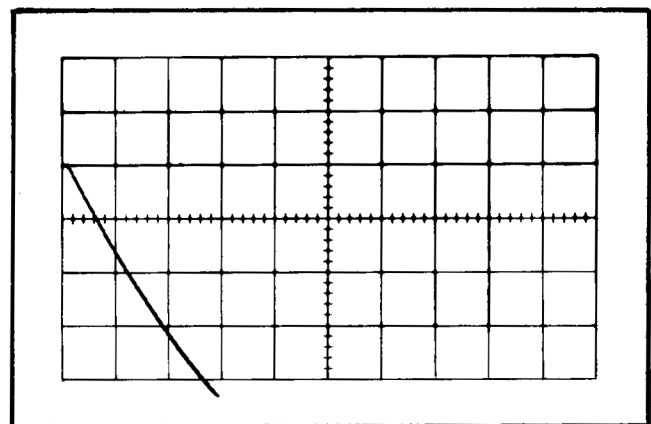

Fig. 6-55. Typical CRT display when checking DELAY-TIME MULTIPLIER dial incremental linearity.

71. Check Delay-Time Jitter

a. Change the following controls settings:

DELAY-TIME MULTIPLIER 1.00
B TIME/DIV 1 μ s

TABLE 6-8
Delayed Sweep Accuracy

| A TIME/DIV switch setting | B TIME/DIV switch setting | Time-Mark Generator Output | Allowable Error for Given Accuracy |
|---------------------------|---------------------------|----------------------------|--|
| 1 μ s | .1 μ s | 1 microsecond | ± 12 minor dial divisions ($\pm 1.5\%$) |
| 2 μ s | .1 μ s | 1 microsecond | |
| 5 μ s | .5 μ s | 5 microsecond | |
| 10 μ s | 1 μ s | 10 microsecond | |
| 20 μ s | 1 μ s | 10 microsecond | |
| 50 μ s | 5 μ s | 50 microsecond | |
| .1 ms | 10 μ s | 0.1 millisecond | |
| .2 ms | 10 μ s | 0.1 millisecond | |
| .5 ms | 50 μ s | 0.5 millisecond | |
| 1 ms | .1 ms | 1 millisecond | |
| 2 ms | .1 ms | 1 millisecond | |
| 5 ms | .5 ms | 5 millisecond | |
| 10 ms | 1 ms | 10 millisecond | |
| 20 ms | 1 ms | 10 millisecond | |
| 50 ms | 5 ms | 50 millisecond | ± 20 minor dial divisions ($\pm 2.5\%$) |
| .1 s | 10 ms | 0.1 second | |
| .2 s | 10 ms | 0.1 second | |
| .5 s | 50 ms | 0.5 second | |
| 1 s | .1 s | 1 second | |
| 2 s | .1 s | 1 second | |
| 5 s | .5 s | 5 second | |

b. Position the pulse near the center of the display area with the DELAY-TIME MULTIPLIER dial.

c. CHECK—Jitter on the leading edge of the pulse should not exceed 0.5 division (1 part in 20,000); see Fig. 6-56). Disregard slow drift.

d. Turn the DELAY-TIME MULTIPLIER dial to 9.00 and adjust so the pulse is displayed near the center of the display area.

e. CHECK—Jitter on leading edge of the pulse should not exceed 0.5 division; see Fig. 6-56. Disregard slow drift.

f. Disconnect all test equipment.

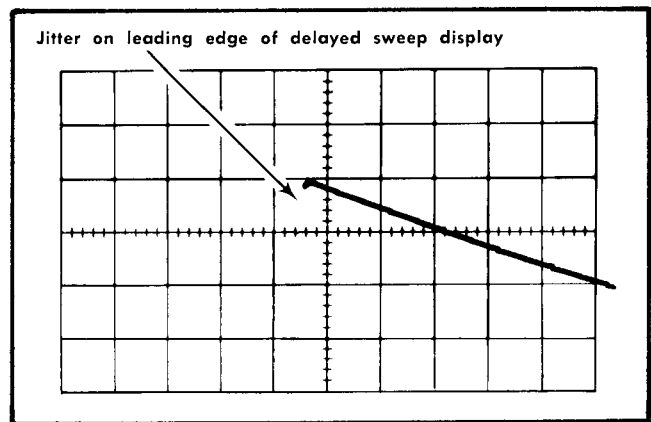

Fig. 6-56. Typical CRT display when checking delay-time jitter.

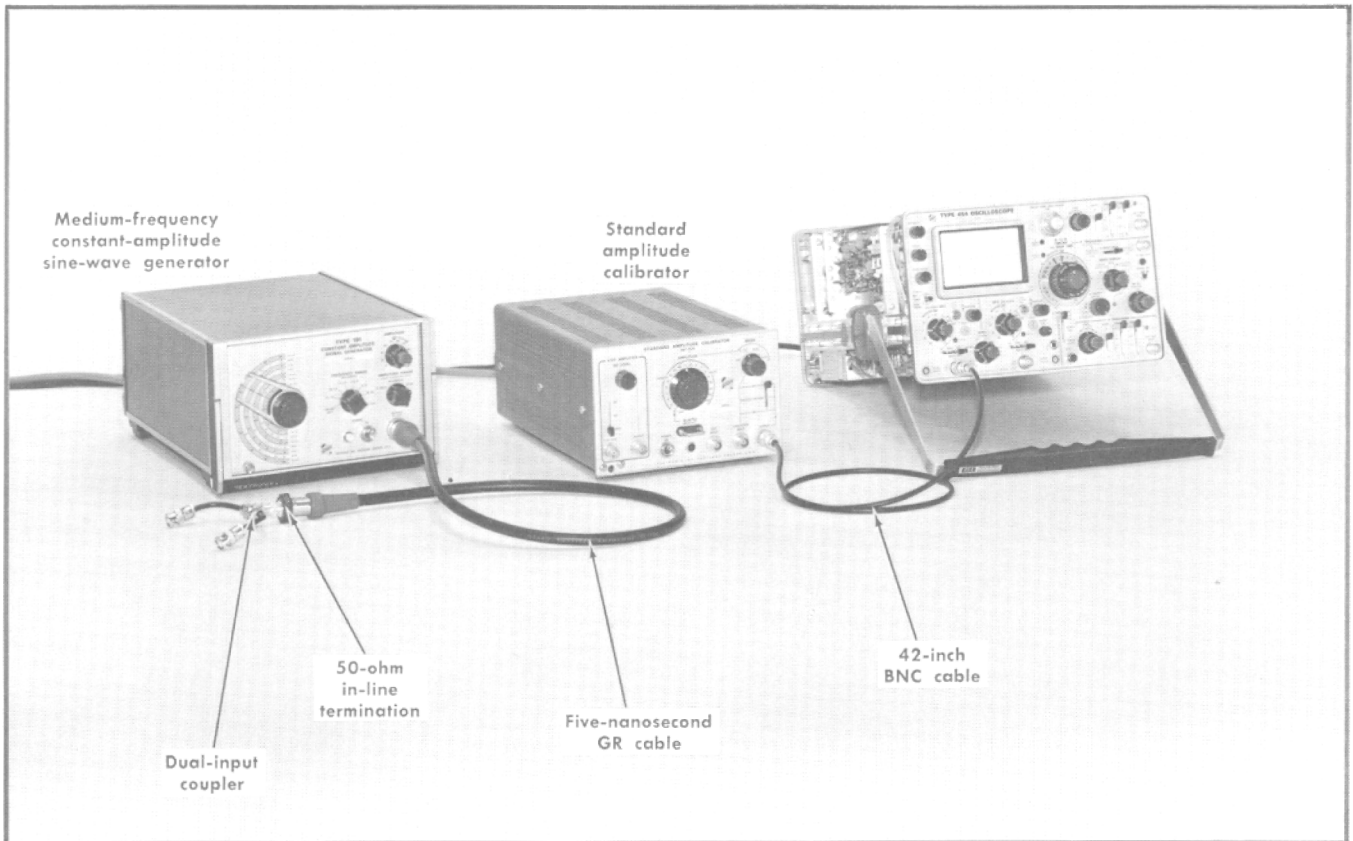

Fig. 6-57. Initial test equipment setup for steps 72 through 76.

CRT controls

INTENSITY Midrange
 FOCUS Adjust for focused display
 SCALE ILLUM As desired
 BW-BEAM FINDER FULL

Vertical controls (both channels if applicable)

VOLTS/DIV **20 mV**
 VARIABLE CAL
 POSITION Midrange
 Input Coupling DC
MODE **CH 2**
TRIGGER **CH 1 ONLY OR X-Y**
 INVERT Pushed in

Triggering controls (both A and B if applicable)

LEVEL Any position
 SLOPE +
 COUPLING AC
 SOURCE INT

Sweep controls

DELAY-TIME MULTIPLIER 9.00
 A TIME/DIV 1 ms
B TIME/DIV **1 ms**

A VARIABLE CAL
 A SWEEP MODE AUTO TRIG
 B SWEEP MODE B STARTS AFTER DELAY TIME

HORIZ DISPLAY **X-Y**
 MAG OFF
 A SWEEP LENGTH FULL
 POSITION Midrange
 POWER ON

Side-panel controls

B TIME/DIV VARIABLE CAL

72. Adjust X Gain ❶

- a. Test equipment setup is shown in Fig. 6-57.
- b. Connect the standard amplitude calibrator to the INPUT CH 1 connector with the 42-inch BNC cable.
- c. Set the standard amplitude calibrator for a 0.1-volt square-wave output.
- d. Increase the INTENSITY control setting until the display (two dots about five divisions apart) is visible.
- e. Move the display to the center of the graticule with the CH 1 POSITION control.

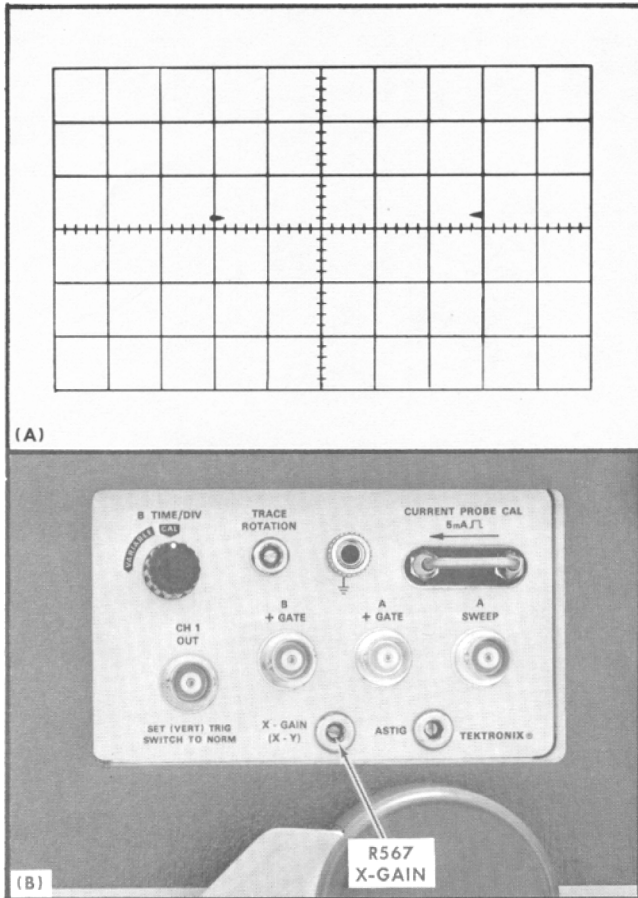

Fig. 6-58. (A) Typical CRT display showing correct X Gain, (B) location of X-GAIN adjustment (side panel).

- f. CHECK—CRT display for five divisions horizontal deflection (see Fig. 6-58A).
- g. ADJUST—X-GAIN adjustment, R567 (see Fig. 6-58B), for exactly five divisions horizontal deflection.
- h. Disconnect all test equipment.

73. Adjust X-Y Phasing



- a. Connect the medium-frequency constant-amplitude sine-wave generator to the INPUT CH 1 and INPUT CH 2 connectors through the five-nanosecond GR cable, 50-ohm in-line termination and the dual-input connector.
- b. Change the following control settings:

| | |
|----------------|-------|
| CH 1 VOLTS/DIV | 10 mV |
| CH 2 VOLTS/DIV | 50 mV |
- c. Set the medium-frequency generator for a 10-division horizontal display at about one megahertz.
- d. Center the display vertically and horizontally with the CH 1 and CH 2 POSITION controls.
- e. CHECK—CRT display for an opening at the center horizontal line of 0.52 division or less (3° or less phase shift; see Fig. 6-59A).

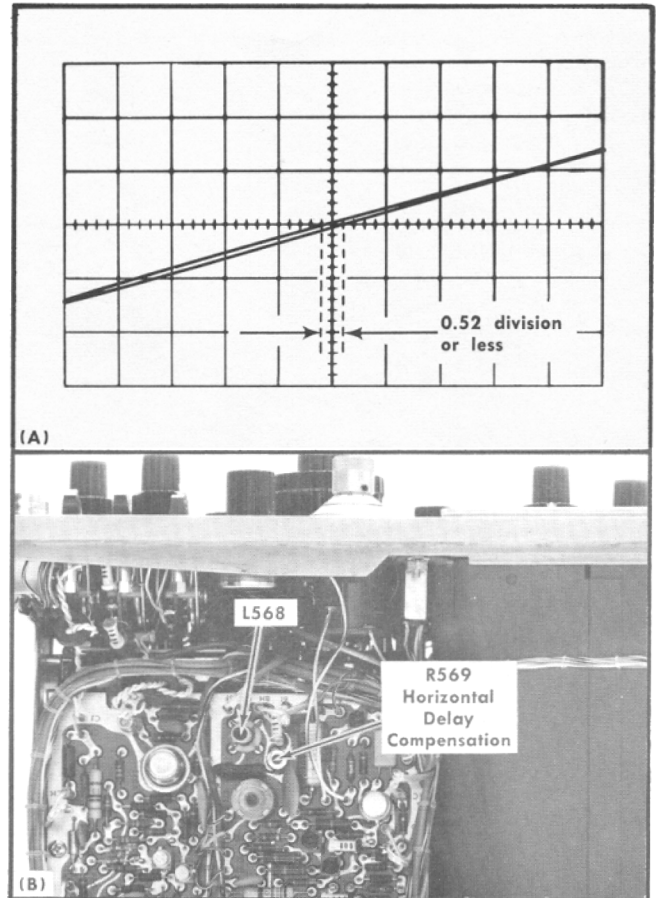

Fig. 6-59. (A) Typical CRT display when checking X-Y phasing, (B) location of X-Y phasing adjustments (B Sweep board).

- f. ADJUST—Horizontal Delay Compensation adjustment, R569 (see Fig. 6-59B) for minimum opening of the display at the center of the horizontal line.
- g. Set the medium-frequency generator for a 10-division horizontal display at two megahertz.
- h. If necessary, recenter the display with the CH 1 and CH 2 POSITION controls.
- i. CHECK—CRT display for an opening at the center horizontal line of 0.52 division or less (3° or less phase shift; see Fig. 6-59A).
- j. ADJUST—L568 (see Fig. 6-59B), for minimum opening of the display at the center horizontal line.
- k. Repeat parts c through j until optimum phasing is obtained.
- l. Set the medium-frequency generator for a 10-division horizontal display at about 0.5 megahertz.
- m. If necessary, recenter the display with the CH 1 and CH 2 POSITION controls.
- n. CHECK—CRT display for an opening at the center horizontal line of 0.52 division or less (3° or less phase shift; see Fig. 6-59A).

- o. ADJUST—Compromise the adjustment of R569 at 0.5 and one megahertz for optimum phasing at both frequencies.
- p. If R569 is adjusted in part o, repeat parts c through n until optimum phasing is obtained.

74. Check X Bandwidth in X-Y Mode

- a. Disconnect the dual-input coupler from the INPUT CH 2 connector.
- b. Set the medium-frequency generator for a six-division horizontal display at its reference frequency (50 kHz).
- c. Set the generator to its variable frequency position.
- d. Without changing the output amplitude, increase the output frequency of the generator until the horizontal deflection is reduced to 4.2 divisions (−3 dB point; see Fig. 6-60).
- e. CHECK—Output frequency of generator must be two megahertz or higher.

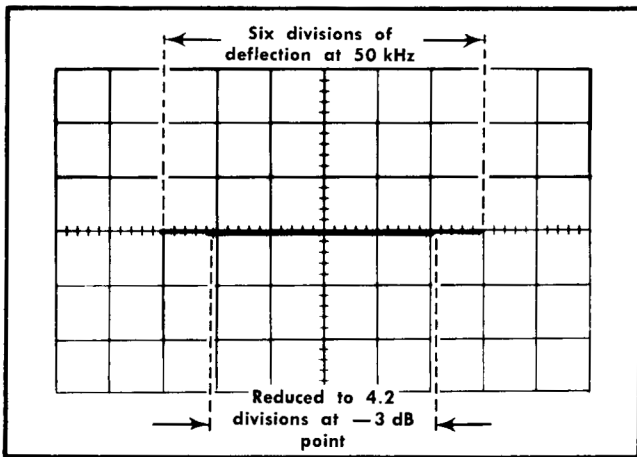

Fig. 6-60. Typical CRT display when checking X-Y bandwidth (double exposure).

75. Check Beam Finder Operation

- a. Reconnect the dual-input coupler to the INPUT CH 2 connector.
- b. While holding the BW-BEAM FINDER switch down, rotate the CH 1 and CH 2 POSITION controls and the CH 1 and CH 2 VOLTS/DIV switches throughout their range.
- c. CHECK—CRT display remains within the graticule area.

d. While holding the BW-BEAM FINDER switch down, adjust the positioning controls until the display is centered about the graticule centerlines. Then, increase the X and Y deflection factors until the display is reduced to about two divisions vertically and about four divisions horizontally.

- e. Release the BW-BEAM FINDER switch.
- f. CHECK—CRT display must remain within the graticule area.
- g. Reduce the INTENSITY control to a normal setting.
- h. Disconnect all test equipment.

76. Check Chopped Operation

- a. Change the following control settings:

| | |
|------------------|------------|
| MODE | CHOP |
| TRIGGER | NORM |
| A and B TIME/DIV | .2 μ s |
| HORIZ DISPLAY | A |
- b. Position the traces about four divisions apart.
- c. Set the A LEVEL control for a stable display.
- d. CHECK—Each cycle for duration of 4.2 to 6.25 divisions (one megahertz, $\pm 20\%$; see Fig. 6-61).
- e. CHECK—Length of each segment between 2.1 and 3.1 divisions (416 to 625 nanoseconds; see Fig. 6-61).
- f. CHECK—CRT display for complete blanking of switching transients between chopped segments (see Fig. 6-61).

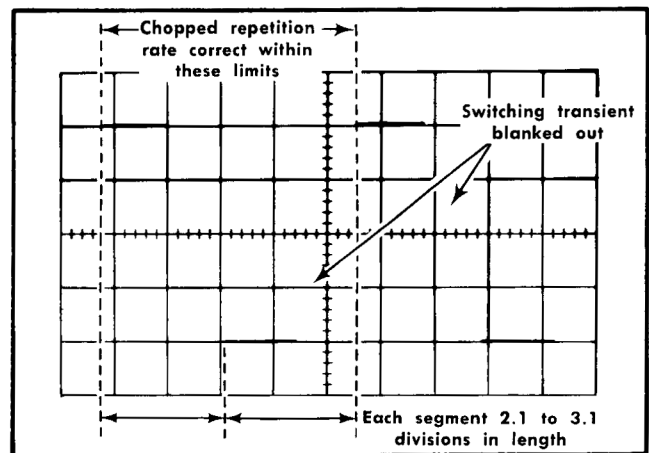

Fig. 6-61. Typical CRT display when checking chopped repetition rate and blanking.

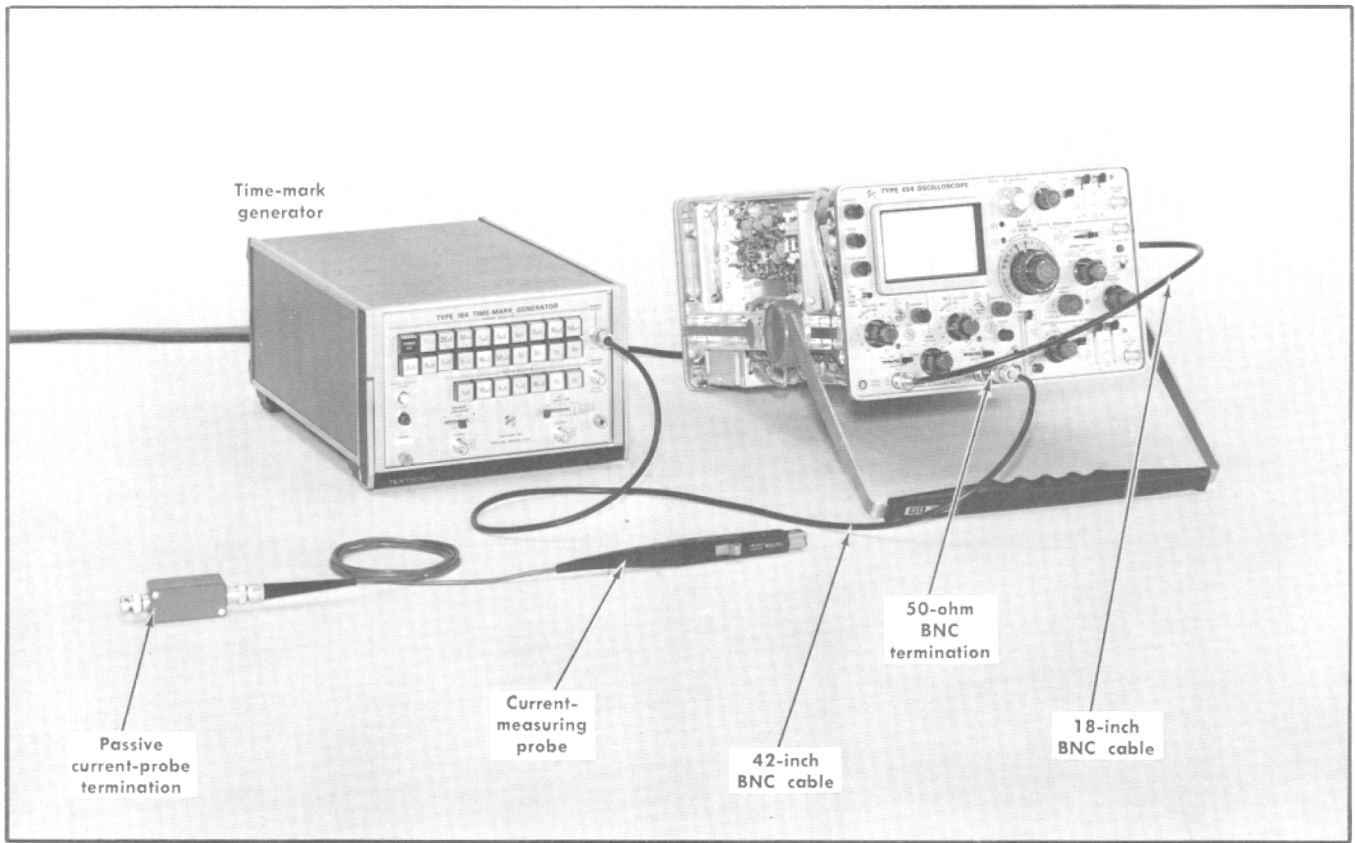

Fig. 6-62. Initial test equipment setup for steps 77 through 80.

CRT controls

| | |
|----------------|----------------------------|
| INTENSITY | Midrange |
| FOCUS | Adjust for focused display |
| SCALE ILLUM | As desired |
| BW-BEAM FINDER | FULL |

Vertical controls (both channels) if applicable

| | |
|-----------------------|------------|
| CH 1 VOLTS/DIV | .5 |
| CH 2 VOLTS/DIV | .2 |
| VARIABLE | CAL |
| POSITION | Midrange |
| Input Coupling | DC |
| MODE | ALT |
| TRIGGER | NORM |
| INVERT | Pushed in |

Triggering controls (both A and B if applicable)

| | |
|----------|----------------|
| LEVEL | Stable display |
| SLOPE | + |
| COUPLING | AC |
| SOURCE | INT |

Sweep controls

| | |
|-----------------------|-------------|
| DELAY-TIME MULTIPLIER | 9.00 |
| A TIME/DIV | 1 ms |

B TIME/DIV

A VARIABLE
A SWEEP MODE
B SWEEP MODE

HORIZ DISPLAY
MAG
A SWEEP LENGTH
POSITION
POWER

Side-panel controls

B TIME/DIV VARIABLE CAL

1 ms

CAL
AUTO TRIG
B STARTS AFTER DELAY TIME

A
OFF
FULL
Midrange
ON

77. Adjust Calibrator Repetition Rate **1**

- a. Test equipment setup is shown in Fig. 6-62.
- b. Connect the 1 V CAL 1 kHz connector to the INPUT CH 1 connector with an 18-inch BNC cable.
- c. Connect the time-mark generator to the INPUT CH 2 connector through a 42-inch 50-ohm BNC cable and a 50-ohm BNC termination.
- d. Set the time-mark generator for one-millisecond markers.
- e. Position the display so the tips of the markers fall just below the rising portions of the square wave (see Fig. 6-63A).

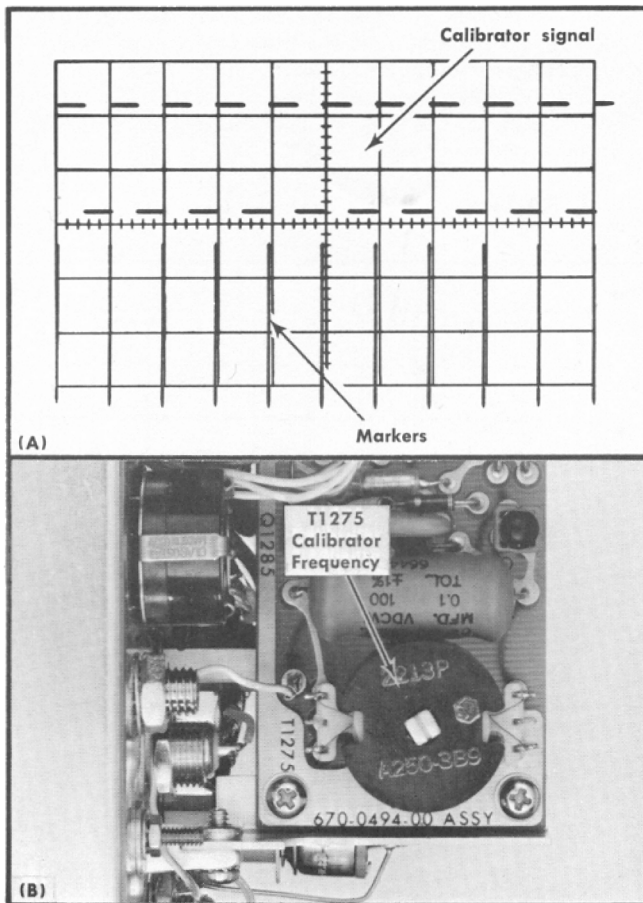

Fig. 6-63. (A) Typical CRT display showing correct calibrator repetition rate, (B) location of Calibrator Frequency adjustment (Calibrator circuit board).

- f. CHECK—For one cycle of calibrator waveform for each marker (see Fig. 6-63A).
- g. ADJUST—Calibrator Frequency adjustment, T1275 (behind swing-out side panel; see Fig. 6-63B), for one cycle of the calibrator waveform for each marker (preliminary adjustment).
- h. Set the TRIGGER switch to CH 1 ONLY.
- i. CHECK—CRT display for slow drift, or no drift, of the time markers.
- j. ADJUST—T1275 for minimum drift of the time markers (final adjustment).
- k. Disconnect the time-mark generator.

78. Check Calibrator Duty Cycle

- a. Change the following control settings:

| | |
|------------------|-------|
| CH 1 VOLTS/DIV | .2 V |
| MODE | CH 1 |
| A and B TIME/DIV | .1 ms |
- b. Center the display vertically with the CH 1 POSITION control.

- c. Set the A LEVEL control so the display starts at the 50% point on the rising portion of the waveform (the INTENSITY control may need to be advanced slightly to see the rising portion of the waveform).
- d. Set the MAG switch to $\times 10$.
- e. Position the 50% point on the falling edge of the Calibrator waveform to the center vertical line.
- f. Set the A SLOPE switch to —.
- g. CHECK—50% point on rising edge now displayed not displaced more than two divisions from the center vertical line (duty cycle 49% to 51%; see Fig. 6-64).

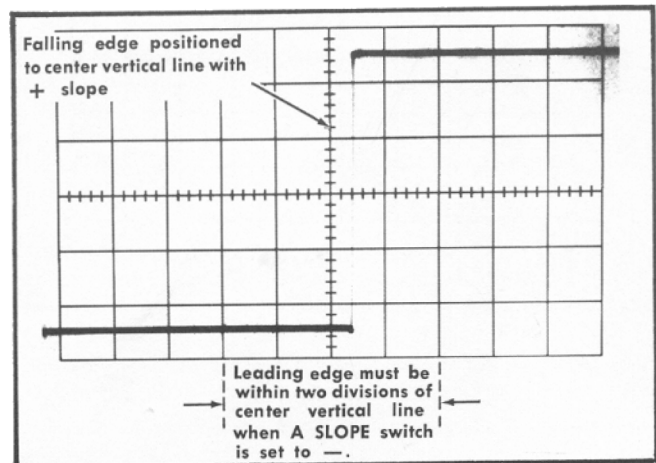

Fig. 6-64. Typical CRT display when checking calibrator duty cycle.

79. Check Calibrator Risetime

- a. Change the following control settings:

| | |
|------------------|------------|
| A SLOPE | + |
| A and B TIME/DIV | .2 μ s |
| MAG | OFF |
- b. Set the A LEVEL control so all of the rising portion of the Calibrator waveform is visible.
- c. Position the 10% point on the leading edge to a vertical graticule line.
- d. CHECK—CRT display for five divisions or less between the 10% and 90% points on the leading edge of the calibrator waveform (one-microsecond or less risetime; see Fig. 6-65).

80. Check Current Through Current Probe Cal Loop

- a. Connect the current-measuring probe and passive termination to the CH 1 INPUT connector.
- b. Set the passive termination for a sensitivity of 2 mA/mV.
- c. Clip the current probe around the CURRENT PROBE CAL loop.
- d. Set the CH 1 VOLTS/DIV switch to 5 mV.

Calibration—Type 454/R454

- e. Set the A and B TIME/DIV switch to .5 ms.
- f. CHECK—CRT display 0.5 division in amplitude (see Fig. 6-66).

NOTE

This step checks for the presence of current in the CURRENT PROBE CAL loop. This current will re-

main within the stated 1% accuracy due to the tolerance of the divider resistors and tolerance of the calibrator output voltage (adjusted in step 2). If it is necessary to verify the accuracy of the calibrator current, use a current measuring meter with an accuracy of at least 0.25%.

- g. Disconnect all test equipment.

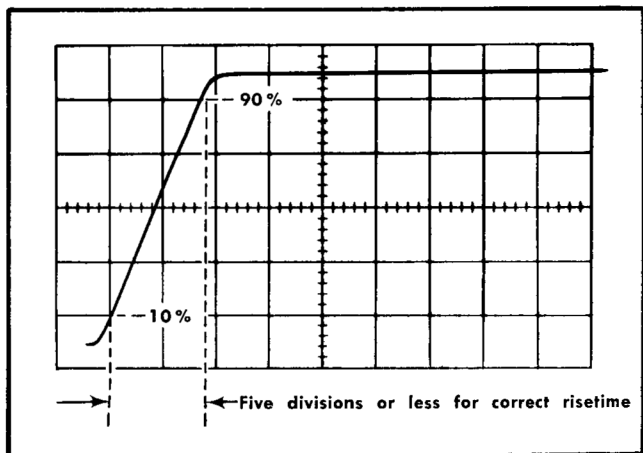

Fig. 6-65. Typical CRT display when checking calibrator risetime.

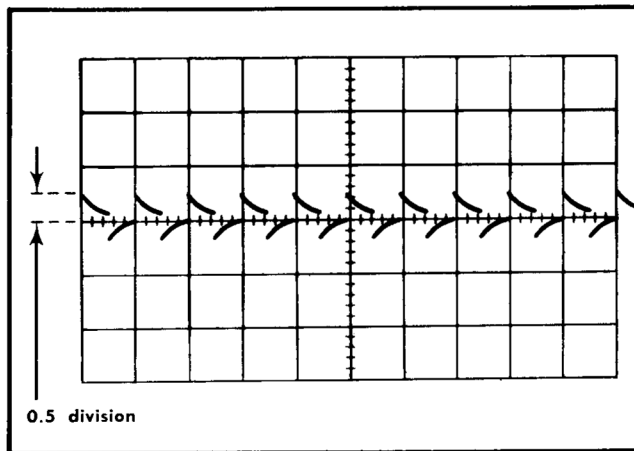

Fig. 6-66. Typical CRT display when checking calibrator current.

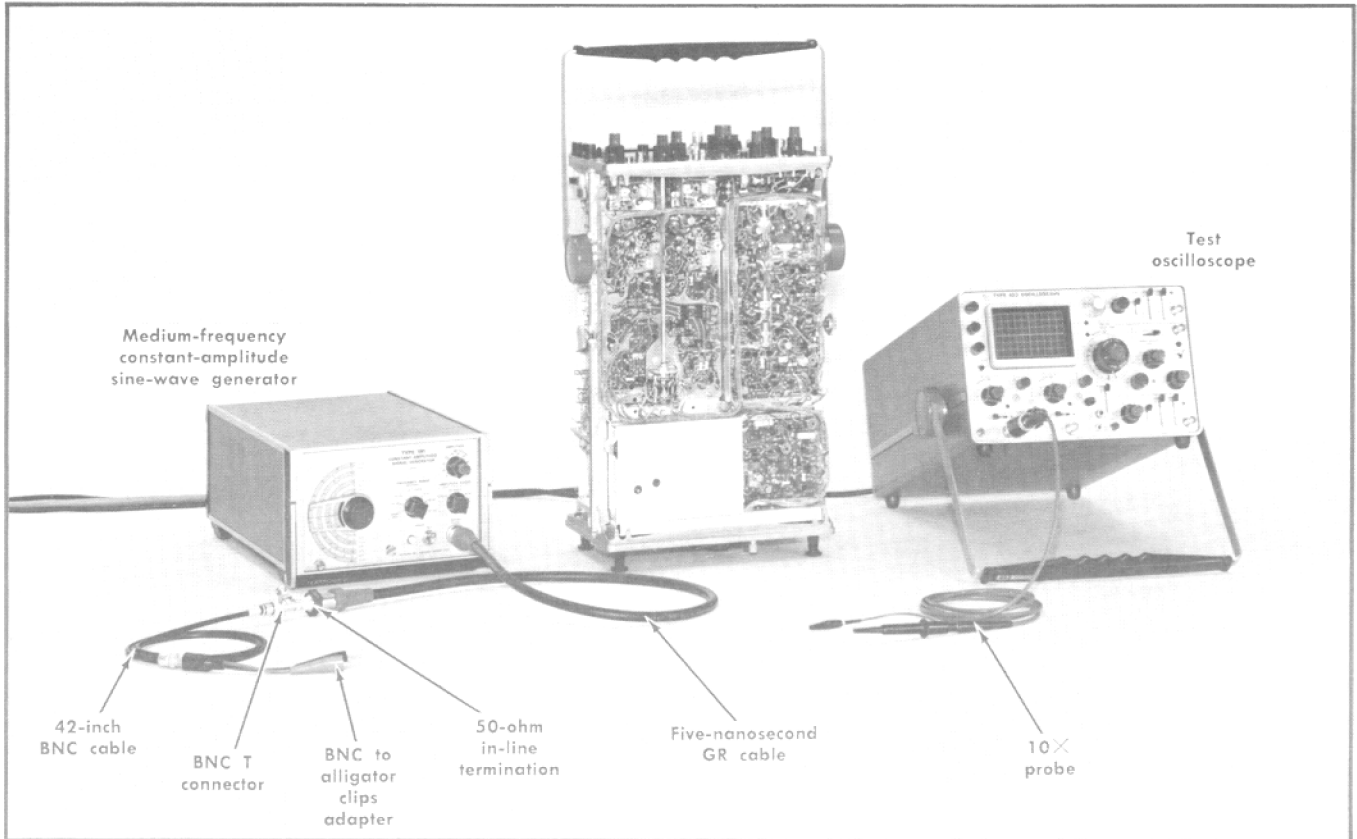

Fig. 6-67. Initial test equipment setup for steps 81 through 85.

CRT controls

INTENSITY Midrange
 FOCUS Adjust for focused display
 SCALE ILLUM As desired
 BW-BEAM FINDER FULL

Vertical controls (both channels if applicable)

VOLTS/DIV .5
 VARIABLE CAL
 POSITION Midrange
 Input Coupling DC
 MODE CH 1
 TRIGGER NORM
 INVERT Pushed in

Triggering controls (both A and B if applicable)

LEVEL 0
 SLOPE +
 COUPLING AC
 SOURCE INT

Sweep controls

DELAY-TIME MULTIPLIER 0.10
A TIME/DIV .1 μ s
B TIME/DIV .1 μ s

A VARIABLE
 A SWEEP MODE
 B SWEEP MODE
 HORIZ DISPLAY
 MAG
 A SWEEP LENGTH
 POSITION
 POWER

CAL
 AUTO TRIG
 B STARTS AFTER DELAY TIME
 A
 OFF
 FULL
 Midrange
 ON

Side-panel controls

B TIME/DIV VARIABLE CAL

81. Adjust Z Axis Compensation **I**

- a. Test equipment setup is shown in Fig. 6-67.
- b. Connect the 10 \times probe to the input connector of the test oscilloscope.
- c. Connect the 10 \times probe tip to TP1349 (see Fig. 6-68A).
- d. Set the test oscilloscope for a vertical deflection factor of 0.5 volts/division (5 volts/division with probe) at a sweep rate of 0.1 microsecond/division.
- e. Set the INTENSITY control so the test oscilloscope display is three divisions in amplitude.

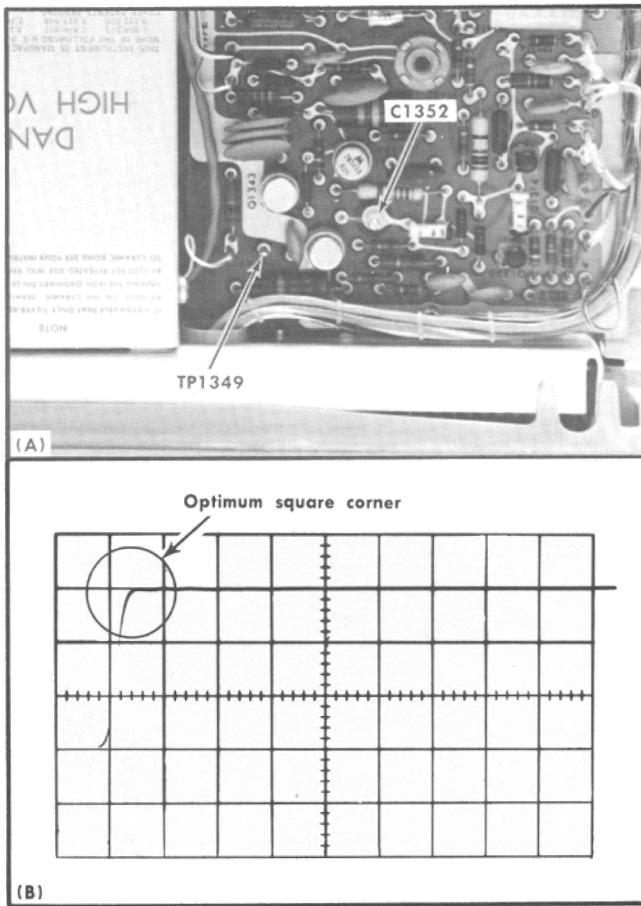

Fig. 6-68. (A) Location of TP1349 and C1352 (Z Axis Amplifier circuit board), (B) typical test oscilloscope display showing correct adjustment of C1352 (vertical deflection, 5 volts/division; sweep rate, 0.1 microsecond/division).

- f. CHECK—Test oscilloscope display for optimum square corner (slightly rounded) on unblanking gate (see Fig. 6-68B).
- g. ADJUST—C1352 (see Fig. 6-68A) for optimum square corner on the unblanking gate.
- h. Disconnect all test equipment.

82. Check External Z Axis Operation

- a. Set the INTENSITY control to a normal setting.
- b. Set the A and B TIME/DIV switch to 20 μ s.
- c. Connect the medium-frequency generator to the A EXT TRIG INPUT connector through the five-nanosecond GR cable, 50-ohm in-line termination and BNC T connector. Connect the output of the BNC T connector to the Z AXIS INPUT binding posts through a 42-inch BNC cable and the BNC to alligator clip adapter. (Connect black lead of alligator clip adapter to ground post.)
- d. Set the A SOURCE switch to EXT.
- e. Remove the ground strap from between the binding posts.
- f. Set the medium-frequency generator for five volts output at 50 kilohertz (use calibrated position of generator amplitude control).

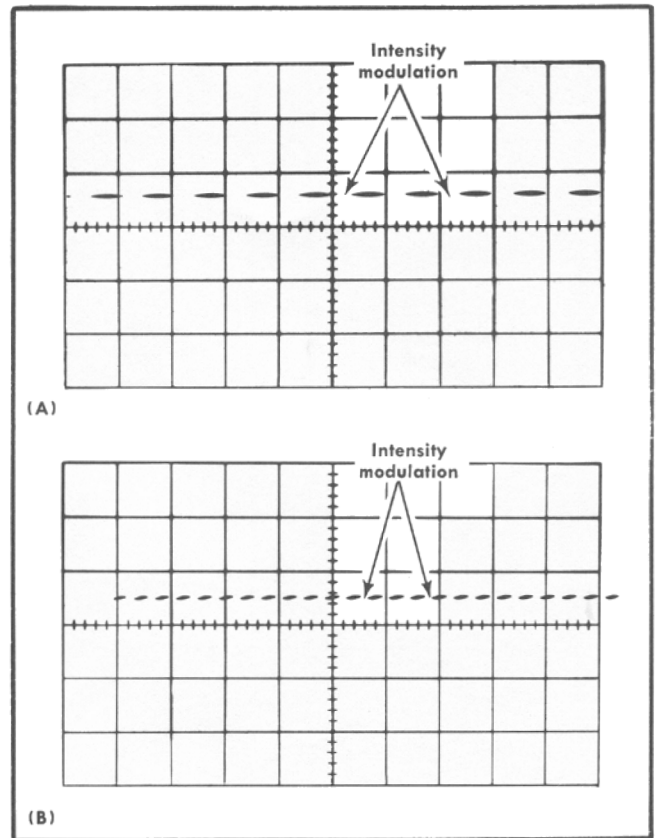

Fig. 6-69. (A) Typical CRT display when checking Z-axis operation at 50 kilohertz, (B) typical CRT display when checking Z-axis operation at 50 megahertz.

- g. CHECK—CRT display for noticeable intensity modulation (see Fig. 6-69A). The INTENSITY control setting may need to be reduced to view trace modulation.
- h. Set the constant-amplitude generator for five volts output at 50 megahertz (use calibrated position of generator amplitude control).
- i. Set the A and B TIME/DIV switch to 0.05 μ s.
- j. CHECK—CRT display for noticeable intensity modulation (see Fig. 6-69B). The INTENSITY control setting may need to be reduced to view trace modulation.
- k. Disconnect all test equipment and replace ground strap.

83. Check A + Gate Output Signal

- a. Set the A and B TIME/DIV switch to 1 ms.
- b. Connect the A + GATE connector (on side panel) to the test-oscilloscope input connector with the 42-inch BNC cable.
- c. Set the test oscilloscope for a vertical deflection factor of five volts/division at a sweep rate of two milliseconds/division.
- d. CHECK—Test oscilloscope display for 2.5 division, ± 0.25 division, vertical deflection with the bottom of the waveform about 0.1 division below the zero-volt level (12.6 volts, $\pm 10\%$ see Fig. 6-70). Gate duration should be about 5.5 divisions (about 11 times the A TIME/DIV switch setting).

84. Check A Sweep Output Signal

- a. Connect the A SWEEP connector (on side panel) to the test oscilloscope input connector with the 42-inch BNC cable.
- b. CHECK—Test oscilloscope display for vertical deflection of two divisions, ± 0.2 divisions with the bottom of the waveform near the zero-volt level (10 volts, $\pm 10\%$; see Fig. 6-71). Sweep duration should be about 5.5 divisions (about 11 times the A TIME/DIV switch setting).

85. Check B + Gate Output Signal

- a. Connect the B + GATE connector (on side panel) to the test-oscilloscope input connector with the 42-inch BNC cable.
- b. Change the following control settings:

| | |
|---------------|-------------------|
| A TIME/DIV | 2 ms |
| B TIME/DIV | 1 ms |
| HORIZ DISPLAY | B (DELAYED SWEEP) |

- c. CHECK—Test oscilloscope display for 2.5 divisions, ± 0.25 division, vertical deflection with the bottom of the waveform about 0.1 division below the zero-volt level (12.6 volts $\pm 10\%$; see Fig. 6-70). Gate duration should be about 5.5 divisions (about 11 times the B TIME—DIV switch setting).

This completes the calibration procedure for the Type 454. Disconnect all test equipment and replace the top and bottom covers. If the instrument has been completely checked and calibrated to the tolerances given in this procedure, it will meet the electrical characteristics listed in the Performance Requirement column of the Type 454/R454 Specifications section of this manual.

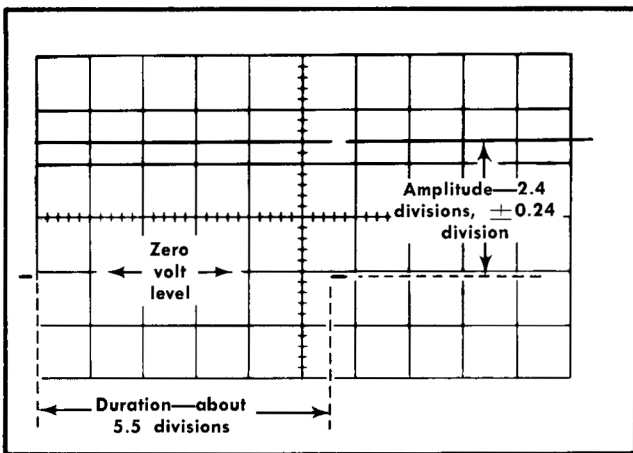

Fig. 6-70. Typical test oscilloscope display when checking A and B GATE amplitude and duration (vertical deflection factor, five volts/division; sweep rate, two milliseconds/division).

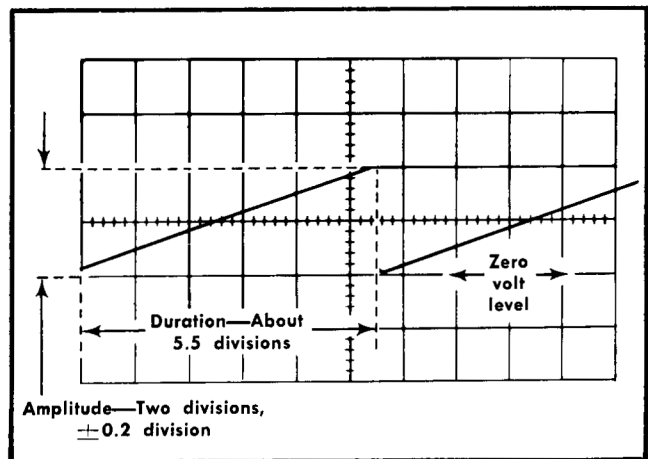

Fig. 6-71. Typical test oscilloscope display when checking A SWEEP output amplitude (vertical deflection factor, five volts/division; sweep rate, two milliseconds/division).

PARTS LIST ABBREVIATIONS

| | | | |
|--------|-----------------------------|-----------|-----------------------------------|
| BHB | binding head brass | int | internal |
| BHS | binding head steel | lg | length or long |
| cap. | capacitor | met. | metal |
| cer | ceramic | mtg hdw | mounting hardware |
| comp | composition | OD | outside diameter |
| conn | connector | OHB | oval head brass |
| CRT | cathode-ray tube | OHS | oval head steel |
| csk | countersunk | PHB | pan head brass |
| DE | double end | PHS | pan head steel |
| dia | diameter | plstc | plastic |
| div | division | PMC | paper, metal cased |
| elect. | electrolytic | poly | polystyrene |
| EMC | electrolytic, metal cased | prec | precision |
| EMT | electrolytic, metal tubular | PT | paper, tubular |
| ext | external | PTM | paper or plastic, tubular, molded |
| F & I | focus and intensity | RHB | round head brass |
| FHB | flat head brass | RHS | round head steel |
| FHS | flat head steel | SE | single end |
| Fil HB | fillister head brass | SN or S/N | serial number |
| Fil HS | fillister head steel | SW | switch |
| h | height or high | TC | temperature compensated |
| hex. | hexagonal | THB | truss head brass |
| HHB | hex head brass | thk | thick |
| HHS | hex head steel | THS | truss head steel |
| HSB | hex socket brass | tub. | tubular |
| HSS | hex socket steel | var | variable |
| ID | inside diameter | w | wide or width |
| incd | incandescent | WW | wire-wound |



PARTS ORDERING INFORMATION

Replacement parts are available from or through your local Tektronix, Inc. Field Office or representative.

Changes to Tektronix instruments are sometimes made to accommodate improved components as they become available, and to give you the benefit of the latest circuit improvements developed in our engineering department. It is therefore important, when ordering parts, to include the following information in your order: Part number, instrument type or number, serial or model number, and modification number if applicable.

If a part you have ordered has been replaced with a new or improved part, your local Tektronix, Inc. Field Office or representative will contact you concerning any change in part number.

SPECIAL NOTES AND SYMBOLS

| | |
|---|---|
| ×000 | Part first added at this serial number |
| 00× | Part removed after this serial number |
| *000-0000-00 | Asterisk preceding Tektronix Part Number indicates manufactured by or for Tektronix, Inc., or reworked or checked components. |
| Use 000-0000-00 | Part number indicated is direct replacement. |
|  | Screwdriver adjustment. |
|  | Control, adjustment or connector. |

SECTION 7

ELECTRICAL PARTS LIST

Values are fixed unless marked Variable.

| Ckt. No. | Tektronix Part No. | Serial/Model No. Eff | Disc | Description |
|-------------------|-----------------------|-------------------------|-----------------------|-------------|
| Bulbs | | | | |
| B16 | 150-0035-00 | | Neon | A1D T2 |
| B63 | 150-0035-00 | | Neon | A1D T2 |
| B116 | 150-0035-00 | | Neon | A1D T2 |
| B163 | 150-0035-00 | | Neon | A1D T2 |
| B505 | 150-0035-00 | | Neon | A1D T2 |
| B506 | 150-0035-00 | | Neon | A1D T2 |
| B619 | 150-0035-00 | | Neon | A1D T2 |
| B740W | 150-0035-00 | | Neon | A1D T2 |
| B792 ¹ | 260-0717-00 | | | |
| B793 | 150-0046-00 | | Incandescent #21070 | |
| B819 | 150-0035-00 | | Neon | A1D T2 |
| B1050 | 150-0035-00 | | Neon | A1D T2 |
| B1107 | 150-0045-00 | | Incandescent #685 | |
| B1108 | 150-0047-00 | | Incandescent #CN8-398 | |
| B1109 | 150-0047-00 | | Incandescent #CN8-398 | |
| B1473 | 150-0030-00 | | Neon | NE 2V |
| B1474 | 150-0030-00 | | Neon | NE 2V |
| B1475 | 150-0030-00 | | Neon | NE 2V |

Capacitors

Tolerance $\pm 20\%$ unless otherwise indicated.

| | | | | | |
|----------------|-------------|---------------------------------|--------------|-------|-----|
| C1 | 285-0738-00 | 0.019 μ F | MT | 600 V | 10% |
| C2 | 281-0651-00 | 47 pF | Cer | | 5% |
| C4 | 281-0513-00 | 27 pF | Cer | 500 V | |
| C5A | 281-0101-00 | 1.5-9.1 pF, Var | Air | | |
| C5C } C5D } | 281-0119-00 | 50 pF 0.2-1.5 pF, Var | Mica Tub. | 250 V | 10% |
| C5E | 281-0544-00 | 5.6 pF (nominal value) Selected | | | |
| C6A | 281-0102-00 | 1.7-11 pF, Var | Air | | |
| C6D } C6E } | 281-0120-00 | 200 pF 0.2-1.5 pF, Var | Mica Tub. | 250 V | 10% |
| C6F | 281-0538-00 | 1 pF (nominal value) Selected | | | |
| C7 | 283-0076-00 | 27 pF | Cer | 500 V | 10% |
| C9 | 281-0064-00 | 0.2-1.5 pF, Var | Tub. | | |
| C10 | 283-0068-00 | 0.01 μ F | Cer | 500 V | |
| C13 | 290-0327-00 | 0.56 μ F | Elect. | 100 V | |
| C18 | 281-0613-00 | 10 pF | Cer | 200 V | 10% |

¹Furnished as a unit with SW783.

Electrical Parts List—Type 454/R454

Capacitors (cont)

| Ckt. No. | Tektronix Part No. | Serial/Model No. | | Description | | | |
|----------|--------------------|------------------|---------|---------------------------------|-------|-------|---------------|
| | | Eff | Disc | | | | |
| C23 | 283-0080-00 | | | 0.022 μ F | Cer | 25 V | +80%—20% |
| C25 | 281-0064-00 | | | 0.2-1.5 pF, Var | Tub. | | |
| C29 | 281-0604-00 | XB040000 | | 2.2 pF | Cer | 500 V | \pm 0.25 pF |
| C30 | 281-0592-00 | B010100 | B039999 | 4.7 pF | Cer | | \pm 0.5 pF |
| C30 | 281-0547-00 | B040000 | | 2.7 pF | Cer | 500 V | 10% |
| C37 | 283-0067-00 | | | 0.001 μ F | Cer | 200 V | 10% |
| C42 | 281-0599-00 | | | 1 pF | Cer | 200 V | \pm 0.25 pF |
| C43 | 281-0064-00 | | | 0.2-1.5 pF, Var | Tub. | | |
| C44 | 283-0080-00 | | | 0.022 μ F | Cer | 25 V | +80%—20% |
| C45 | 281-0123-00 | | | 5-25 pF, Var | Cer | | |
| C49A | 281-0123-00 | | | 5-25 pF, Var | Cer | | |
| C49B | 281-0512-00 | | | 27 pF | Cer | 500 V | 10% |
| C49F | 281-0121-00 | | | 0.85-7 pF, Var | Glass | | |
| C49G | 281-0617-00 | | | 15 pF | Cer | 200 V | |
| C49H | 281-0078-00 | | | 1.4-7.3 pF, Var | Air | | |
| C49J | 281-0121-00 | | | 0.85-7 pF, Var | Glass | | |
| C49N | 281-0078-00 | | | 1.4-7.3 pF, Var | Air | | |
| C56 | 283-0067-00 | | | 0.001 μ F | Cer | 200 V | 10% |
| C58 | 281-0523-00 | | | 100 pF | Cer | 350 V | |
| C60 | 281-0123-00 | | | 5-25 pF, Var | Cer | | |
| C64* | *388-0839-00 | | | T Coil | | | |
| C65 | 281-0612-00 | | | 5.6 pF | Cer | 200 V | \pm 0.5 pF |
| C78 | 281-0122-00 | | | 2.5-9 pF, Var | Cer | | |
| C81 | 283-0003-00 | | | 0.01 μ F | Cer | 150 V | |
| C85 | 283-0080-00 | | | 0.022 μ F | Cer | 25 V | +80%—20% |
| C91 | 283-0003-00 | | | 0.01 μ F | Cer | 150 V | |
| C101 | 285-0738-00 | | | 0.019 μ F | MT | 600 V | 10% |
| C102 | 281-0651-00 | | | 47 pF | Cer | | 5% |
| C104 | 281-0513-00 | | | 27 pF | Cer | 500 V | |
| C105A | 281-0101-00 | | | 1.5-9.1 pF, Var | Air | | |
| C105C | 281-0119-00 | | | 50 pF | Mica | 250 V | 10% |
| C105D | | | | 0.2-1.5 pF, Var | Tub. | | |
| C105E | 281-0544-00 | | | 5.6 pF (nominal value) Selected | | | |
| C106A | 281-0102-00 | | | 1.7-11 pF, Var | Air | | |
| C106D | 281-0120-00 | | | 200 pF | Mica | 250 V | 10% |
| C106E | | | | 0.2-1.5 pF, Var | Tub. | | |
| C106F | 281-0538-00 | | | 1 pF (nominal value) Selected | | | |
| C107 | 283-0076-00 | | | 27 pF | Cer | 500 V | 10% |
| C109 | 281-0064-00 | | | 0.2-1.5 pF, Var | Tub. | | |
| C110 | 283-0068-00 | | | 0.01 μ F | Cer | 500 V | |
| C113 | 290-0327-00 | | | 0.56 μ F | Elect | 100 V | |
| C118 | 281-0613-00 | | | 10 pF | Cer | 200 V | 10% |
| C123 | 283-0080-00 | | | 0.022 μ F | Cer | 25 V | +80%—20% |
| C125 | 281-0064-00 | | | 0.2-1.5 pF, Var | Tub. | | |
| C129 | 281-0604-00 | XB040000 | | 2.2 pF | Cer | 500 V | \pm 0.25 pF |
| C130 | 281-0592-00 | B010100 | B039999 | 4.7 pF | Cer | | \pm 0.5 pF |
| C130 | 281-0547-00 | B040000 | | 2.7 pF | Cer | 500 V | 10% |

*Furnished as a unit with L64.

Capacitors (cont)

| Ckt. No. | Tektronix Part No. | Serial/Model No. Eff | Disc | Description | | | |
|-------------------|--------------------|----------------------|---------|-----------------|--------|-------|---------------|
| C137 | 283-0067-00 | | | 0.001 μ F | Cer | 200 V | 10% |
| C142 | 281-0599-00 | | | 1 pF | Cer | 200 V | ± 0.25 pF |
| C143 | 281-0064-00 | | | 0.2-1.5 pF, Var | Tub. | | |
| C144 | 283-0080-00 | | | 0.022 μ F | Cer | 25 V | +80%—20% |
| C145 | 281-0123-00 | | | 5-25 pF, Var | Cer | | |
| C149A | 281-0123-00 | | | 5-25 pF, Var | Cer | | |
| C149B | 281-0512-00 | | | 27 pF | Cer | 500 V | 10% |
| C149F | 281-0121-00 | | | 0.85-7 pF, Var | Glass | | |
| C149G | 281-0617-00 | | | 15 pF | Cer | 200 V | |
| C149H | 281-0078-00 | | | 1.4-7.3 pF, Var | Air | | |
| C149J | 281-0121-00 | | | 0.85-7 pF, Var | Glass | | |
| C149N | 281-0078-00 | | | 1.4-7.3 pF, Var | Air | | |
| C150 | 281-0503-00 | B010100 | B039999 | 8 pF | Cer | 500 V | ± 0.5 pF |
| C150 | 281-0122-00 | B040000 | | 2.5-9 pF, Var | Cer | | |
| C160 | 281-0123-00 | | | 5-25 pF, Var | Cer | | |
| C164 ⁸ | *388-0839-00 | | | T Coil | | | |
| C165 | 281-0612-00 | | | 5.6 pF | Cer | 200 V | ± 0.5 pF |
| C178 | 281-0122-00 | | | 2.5-9 pF, Var | Cer | | |
| C181 | 283-0003-00 | | | 0.01 μ F | Cer | 150 V | |
| C185 | 283-0080-00 | | | 0.022 μ F | Cer | 25 V | +80%—20% |
| C191 | 283-0003-00 | | | 0.01 μ F | Cer | 150 V | |
| C215 | 281-0524-00 | | | 150 pF | Cer | 500 V | |
| C218 | 285-0643-00 | B010100 | B209999 | 0.0047 μ F | PTM | 100 V | 5% |
| C218 | 285-0627-00 | B210000 | | 0.0033 μ F | PTM | 100 V | 5% |
| C225 | 281-0524-00 | | | 150 pF | Cer | 500 V | |
| C238 | 290-0267-00 | | | 1 μ F | Elect. | 35 V | |
| C241 | 281-0549-00 | B010100 | B209999 | 68 pF | Cer | 500 V | 10% |
| C241 | 281-0540-00 | B210000 | | 51 pF | Cer | 500 V | 5% |
| C253 | 283-0081-00 | | | 0.1 μ F | Cer | 25 V | +80%—20% |
| C278 | 281-0503-00 | | | 8 pF | Cer | 500 V | ± 0.5 pF |
| C288 | 281-0503-00 | | | 8 pF | Cer | 500 V | ± 0.5 pF |
| C301 | 281-0604-00 | | | 2.2 pF | Cer | 500 V | ± 0.25 pF |
| C303 | 281-0592-00 | B010100 | B010119 | 4.7 pF | Cer | | ± 0.5 pF |
| C303 | 281-0534-00 | B010120 | | 3.3 pF | Cer | | ± 0.25 pF |
| C304 | 281-0604-00 | | | 2.2 pF | Cer | 500 V | ± 0.25 pF |
| C305 | 281-0534-00 | | | 3.3 pF | Cer | | ± 0.25 pF |
| C307 | 281-0534-00 | | | 3.3 pF | Cer | | ± 0.25 pF |
| C316 | 283-0003-00 | | | 0.01 μ F | Cer | 150 V | |
| C327 | 283-0004-00 | | | 0.02 μ F | Cer | 150 V | |
| C329 | 281-0537-00 | | | 0.68 pF | Cer | 500 V | |
| C330 | 283-0078-00 | | | 0.001 μ F | Cer | 500 V | |
| C335 | 283-0103-00 | | | 180 pF | Cer | 500 V | 5% |
| C336 | 281-0593-00 | XB010120 | | 3.9 pF | Cer | | 10% |

(Added in test if necessary)

⁸Furnished as a unit with L164.

⁴Furnished as a unit with L337.

⁵Furnished as a unit with L368.

Electrical Parts List—Type 454/R454

Capacitors (cont)

| Kct. No. | Tektronix Part No. | Serial/Model No. Eff | Disc | Description | | |
|------------------------------|--------------------|----------------------|---------|----------------|--------|---------------------------------------|
| C375 | 283-0003-00 | | | 0.01 μ F | Cer | 150 V |
| C394 | 281-0537-00 | | | 0.68 pF | Cer | 500 V |
| C396 | 283-0092-00 | | | 0.03 μ F | Cer | 200 V |
| C397 | 283-C392-00 | | | 0.03 μ F | Cer | 200 V |
| C401 | 281-0604-00 | | | 2.2 pF | Cer | 500 V |
| | | | | | | +80%—20% +80%—20% ± 0.25 pF |
| C402 | 281-0080-00 | | | 1.7-11 pF, Var | Air | |
| C403 | 281-0593-00 | B010100 | B010119 | 3.9 pF | Cer | 10% |
| C403 | 281-0534-00 | B010120 | | 3.3 pF | Cer | ± 0.25 pF |
| C405 | 281-0534-00 | | | 3.3 pF | Cer | ± 0.25 pF |
| C406 | 281-0557-00 | | | 1.8 pF | Cer | 500 V |
| C407 | 281-0534-00 | | | 3.3 pF | Cer | ± 0.25 pF |
| C416 | 283-0003-00 | | | 0.01 μ F | Cer | 150 V |
| C426 | 281-0122-00 | | | 2.5-9 pF, Var | Cer | |
| C430 | 283-0078-00 | | | 0.001 μ F | Cer | 500 V |
| C437 ⁶ | *388-0867-00 | | | T Coil, 4T | | |
| C442 | 283-0003-00 | | | 0.01 μ F | Cer | 150 V |
| C455 | 283-0078-00 | | | 0.001 μ F | Cer | 500 V |
| C468 ⁷ | *388-0868-00 | | | T Coil, 3T | | |
| C475 | 283-C303-00 | | | 0.01 μ F | Cer | 150 V |
| C494 | 281-0537-00 | | | 0.68 pF | Cer | 500 V |
| C495 | 281-0609-00 | XB010120 | | 1 pF | Cer | 200 V |
| (Added in test if necessary) | | | | | | 10% |
| C497 | 283-0092-00 | | | 0.03 μ F | Cer | 200 V |
| C512 | 283-0080-00 | | | 0.022 μ F | Cer | 25 V |
| C513 | 290-0267-00 | | | 1 μ F | Elect. | 35 V |
| C519 | 290-0267-00 | | | 1 μ F | Elect. | 35 V |
| C520 | 281-0616-00 | | | 6.8 pF | Cer | 200 V |
| C521 | 281-0603-00 | | | 39 pF | Cer | 500 V |
| C531 | 281-0618-00 | | | 4.7 pF | Cer | 200 V |
| C539 | 290-0267-00 | | | 1 μ F | Elect. | 35 V |
| C544 | 281-0512-00 | | | 27 pF | Cer | 500 V |
| | | | | | | 5% ± 0.5 pF |
| C551 | 281-0653-00 | B010100 | B269999 | 3.3 pF | Cer | 200 V |
| C551 | 281-0615-00 | B270000 | | 3.9 pF | Cer | 200 V |
| C555 | 281-0653-00 | B010100 | B269999 | 3.3 pF | Cer | 200 V |
| C555 | 281-0615-08 | B270000 | | 3.9 pF | Cer | 200 V |
| C560 | 283-0080-00 | | | 0.022 μ F | Cer | 25 V |
| | | | | | | +80%—20% |
| C561 | 290-0267-00 | | | 1 μ F | Elect. | 35 V |
| C568 | 283-0624-00 | | | 1300 pF | Mica | 500 V |
| C569 | 231-0543-00 | | | 270 pF | Cer | 500 V |
| C602 | 281-0558-00 | | | 18 pF | Cer | 500 V |
| C604A | 281-0505-00 | B010100 | B219999 | 12 pF | Cer | 500 V |
| | | | | | | 10% |
| C604A | 281-0628-00 | B220000 | | 15 pF | Cer | 600 V |
| C604C | 281-0557-00 | B010100 | B219999 | 1.8 pF | Cer | 500 V |
| | | | | | | 5% |

⁶Furnished as a unit with L437.

⁷Furnished as a unit with L468.

Capacitors (cont)

| Ckt. No. | Tektronix Part No. | Serial/Model No. | | Description | | | |
|----------|--------------------|------------------|----------|---------------|--------|--------|----------|
| | | Eff | Disc | | | | |
| C604C | 281-0627-00 | B220000 | | 1 pF | Cer | 600 V | |
| C606 | 283-0013-00 | | | 0.01 μ F | Cer | 1000 V | |
| C607 | 281-0523-00 | | | 100 pF | Cer | 350 V | |
| C608 | 281-0504-00 | B010100 | B219999 | 10 pF | Cer | 500 V | 10% |
| C608 | 281-0544-00 | B220000 | | 5.6 pF | Cer | 500 V | 10% |
| C609 | 281-0620-00 | | | 21 pF | Cer | 500 V | 1% |
| C617 | 283-0068-00 | | | 0.01 μ F | Cer | 500 V | |
| C623 | 283-0092-00 | | | 0.03 μ F | Cer | 200 V | +80%—20% |
| C642 | 283-0080-00 | XB220000 | | 0.022 μ F | Cer | 25 V | +80%—20% |
| C645 | 283-0080-00 | | | 0.022 μ F | Cer | 25 V | +80%—20% |
| C651 | 283-0080-00 | | | 0.022 μ F | Cer | 25 V | +80%—20% |
| C652 | 283-C980-00 | | | 0.022 μ F | Cer | 25 V | +80%—20% |
| C659 | 283-0080-00 | | | 0.022 μ F | Cer | 25 V | +80%—20% |
| C662 | 283-0081-00 | B010100 | B219999 | 0.1 μ F | Cer | 25 V | +80%—20% |
| C662 | 283-0080-00 | B220000 | | 0.022 μ F | Cer | 25 V | +80%—20% |
| C664 | 283-0003-00 | B010100 | B059999 | 0.01 μ F | Cer | 150 V | |
| C664 | 283-0000-00 | B060000 | | 0.001 μ F | Cer | 500 V | |
| C666 | 281-0613-00 | XB060000 | | 10 pF | Cer | 200 V | 10% |
| C668 | 283-0067-00 | XB220000 | | 0.001 μ F | Cer | 200 V | 10% |
| C670 | 283-0000-00 | XB220000 | | 0.001 μ F | Cer | 500 V | |
| C671 | 281-0549-00 | B010100 | B219999X | 68 pF | Cer | 500 V | 10% |
| C672 | 283-0080-00 | B010100 | B219999X | 0.022 μ F | Cer | 25 V | +80%—20% |
| C674 | 281-0523-00 | B010100 | B049999 | 100 pF | Cer | 350 V | |
| C674 | 281-0519-00 | B050000 | B059999 | 27 pF | Cer | 500 V | 10% |
| C674 | 281-0512-00 | B060000 | B219999 | 47 pF | Cer | 500 V | 10% |
| C674 | 283-0000-00 | B220000 | | 0.001 μ F | Cer | 500 V | |
| C676 | 283-0081-00 | B010100 | B219999 | 0.1 μ F | Cer | 25 V | +80%—20% |
| C676 | 283-0000-00 | B220000 | | 0.001 μ F | Cer | 500 V | |
| C684 | 283-0000-00 | XB220000 | | 0.001 μ F | Cer | 500 V | |
| C689 | 290-0246-00 | | | 3.3 μ F | Elect. | 15 V | 10% |
| C692 | 290-0267-00 | | | 1 μ F | Elect. | 35 V | |
| C702 | 281-0525-00 | | | 470 pF | Cer | 500 V | |
| C704 | 281-0519-00 | B010100 | B219999 | 47 pF | Cer | 500 V | 10% |
| C704 | 281-0558-00 | B220000 | | 18 pF | Cer | 500 V | |
| C707 | 281-0628-00 | XB220000 | | 15 pF | Cer | 600 V | 5% |
| C713 | 283-0080-00 | | | 0.022 μ F | Cer | 25 V | +80%—20% |
| C721 | 283-0081-00 | | | 0.1 μ F | Cer | 25 V | +80%—20% |
| C722 | 281-0547-00 | B010100 | B239999X | 2.7 pF | Cer | 500 V | 10% |
| C725 | 290-0267-00 | | | 1 μ F | Elect. | 35 V | |
| C726 | 290-0267-00 | | | 1 μ F | Elect. | 35 V | |
| C728 | 281-0513-00 | | | 27 pF | Cer | 500 V | |
| C731 | 283-0092-00 | | | 0.03 μ F | Cer | 200 V | +80%—20% |
| C735 | 281-0558-00 | | | 18 pF | Cer | 500 V | |
| C739 | 283-C980-00 | B010100 | B259999 | 0.022 μ F | Cer | 25 V | +80%—20% |
| C739 | 283-0065-00 | B260000 | | 0.001 μ F | Cer | 100 V | 5% |

Electrical Parts List—Type 454/R454

Capacitors (cont)

| Kct. No. | Tektronix Part No. | Serial/Model No. Eff | Disc | Description | | |
|----------|--------------------|----------------------|---------|----------------|---------------|--------|
| C740A | 281-0010-00 | | | 4.5-25 pF, Var | Cer | |
| C740B | 283-0144-00 | | | 33 pF | Cer | 500 V |
| C740C | 281-0010-00 | | | 4.5-25 pF, Var | Cer | |
| C740D | 283-0097-00 | | | 84 pF | Cer | 1000 V |
| C740E | *295-0089-00 | | | 0.001 μ F | Timing Series | |
| C740F | | | | 0.01 μ F | | |
| C740G | | | | 0.1 μ F | | |
| C740J | | | | 1 μ F | | |
| C740M | | | | 10 μ F | | |
| C740H | 281-0523-00 | | | 100 pF | Cer | 350 V |
| C740K | 283-0032-00 | | | 470 pF | Cer | 500 V |
| C740L | 281-0523-00 | | | 100 pF | Cer | 350 V |
| C758 | 290-0135-00 | | | 15 μ F | Elect. | 20 V |
| C759 | 281-0549-00 | | | 68 pF | Cer | 500 V |
| C760A | 281-0519-00 | | | 47 pF | Cer | 500 V |
| C760B | 281-0525-00 | | | 470 pF | Cer | 500 V |
| C760C | 285-0699-00 | | | 0.0047 μ F | PTM | 100 V |
| C760D | 290-0282-00 | | | 0.047 μ F | Elect. | 35 V |
| C760E | 290-0283-00 | | | 0.47 μ F | Elect. | 35 V |
| C760F | 290-0284-00 | | | 4.7 μ F | Elect. | 35 V |
| C766 | 283-0081-00 | | | 0.1 μ F | Cer | 25 V |
| C774 | 283-0080-00 | | | 0.022 μ F | Cer | 25 V |
| C775 | 281-0519-00 | B010100 | B049999 | 47 pF | Cer | 500 V |
| C775 | 281-0512-00 | B050000 | | 27 pF | Cer | 500 V |
| C778 | 283-0080-00 | | | 0.022 μ F | Cer | 25 V |
| C783 | 281-0523-00 | | | 100 pF | Cer | 350 V |
| C784 | 290-0134-00 | | | 22 μ F | Elect. | 15 V |
| C785 | 281-0523-00 | | | 100 pF | Cer | 350 V |
| C787 | 283-0119-00 | | | 2200 pF | Cer | 200 V |
| C802 | 281-0558-00 | | | 18 pF | Cer | 500 V |
| C804A | 281-0505-00 | B010100 | B219999 | 12 pF | Cer | 500 V |
| C804A | 281-0628-00 | B220000 | | 1.8 pF | Cer | 600 V |
| C804C | 281-0557-00 | B010100 | B219999 | 15 pF | Cer | 500 V |
| C804C | 281-0627-00 | B220000 | | 1 pF | Cer | 600 V |
| C806 | 283-0013-00 | | | 0.01 μ F | Cer | 1000 V |
| C807 | 281-0523-00 | | | 100 pF | Cer | 350 V |
| C808 | 281-0504-00 | B010100 | B219999 | 10 pF | Cer | 500 V |
| C808 | 281-0544-00 | B220000 | | 5.6 pF | Cer | 500 V |
| C809 | 281-0620-00 | | | 21 pF | Cer | 500 V |
| C817 | 283-0068-00 | | | 0.01 μ F | Cer | 500 V |
| C823 | 283-0092-00 | | | 0.03 μ F | Cer | 200 V |
| C829 | 283-0080-00 | | | 0.022 μ F | Cer | 25 V |
| C835 | 283-0080-00 | | | 0.022 μ F | Cer | 25 V |
| C841 | 283-0080-00 | | | 0.022 μ F | Cer | 25 V |
| C851 | 283-0080-00 | | | 0.022 μ F | Cer | 25 V |
| C852 | 283-0080-00 | | | 0.022 μ F | Cer | 25 V |
| C859 | 283-0080-00 | | | 0.022 μ F | Cer | 25 V |
| C862 | 283-0081-00 | | | 0.1 μ F | Cer | 25 V |
| C864 | 283-0003-00 | B010100 | B059999 | 0.01 μ F | Cer | 150 V |

Capacitors (cont)

| Ckt. No. | Tektronix Part No. | Serial/Model No. | | Description | | | |
|----------|--------------------|------------------|------|-----------------|--------|--------|---------------|
| | | Eff | Disc | | | | |
| C864 | 283-0000-00 | B060000 | | 0.001 μ F | Cer | 500 V | |
| C866 | 281-0613-00 | XB060000 | | 10 pF | Cer | 200 V | 10% |
| C871 | 281-0549-00 | | | 68 pF | Cer | 500 V | 10% |
| C902 | 281-0525-00 | | | 470 pF | Cer | 500 V | |
| C904 | 281-0519-00 | | | 47 pF | Cer | 500 V | 10% |
| C921 | 283-0080-00 | | | 0.022 μ F | Cer | 25 V | +80%—20% |
| C924 | 290-0267-00 | | | 1 μ F | Elect. | 35 V | |
| C927 | 290-0267-00 | | | 1 μ F | Elect. | 35 V | |
| C931 | 283-0092-00 | | | 0.03 μ F | Cer | 200 V | +80%—20% |
| C935 | 281-0626-00 | | | 3.3 pF | Cer | 500 V | 5% |
| C939 | 283-0080-00 | | | 0.022 μ F | Cer | 25 V | +80%—20% |
| C940A | 281-0010-00 | | | 4.5-25 pF, Var | Cer | | |
| C940B | 283-0144-00 | | | 33 pF | Cer | 500 V | 1% |
| C940C | 281-0010-00 | | | 4.5-25 pF, Var | Cer | | |
| C940D | 283-0097-00 | | | 84 pF | Cer | 1000 V | 2% |
| C940E | *295-0079-00 | | | 0.001 μ F | Cer | 350 V | Timing Series |
| C940F | | | | 0.01 μ F | | | |
| C940G | | | | 0.1 μ F | | | |
| C940J | | | | 1 μ F | | | |
| C940H | | 281-0523-00 | | | | | |
| C946 | 283-0092-00 | | | 0.03 μ F | Cer | 200 V | +80%—20% |
| C950 | 281-0519-00 | | | 47 pF | Cer | 500 V | 10% |
| C951 | 281-0523-00 | | | 100 pF | Cer | 350 V | |
| C954 | 283-0080-00 | | | 0.022 μ F | Cer | 25 V | +80%—20% |
| C959 | 290-0248-01 | | | 150 μ F | Elect. | 15 V | |
| C960 | 203-C080-00 | | | 0.022 μ F | Cer | 25 V | +80%—20% |
| C965 | 281-0523-00 | | | 100 pF | Cer | 350 V | |
| C967 | 283-0080-00 | | | 0.022 μ F | Cer | 25 V | +80%—20% |
| C970 | 281-0519-00 | | | 47 pF | Cer | 500 V | 10% |
| C979 | 281-0511-00 | | | 22 pF | Cer | 500 V | 10% |
| C990 | 281-0505-00 | | | 12 pF | Cer | 500 V | 10% |
| C1006 | 283-0080-00 | | | 0.022 μ F | Cer | 25 V | +80%—20% |
| C1009 | 283-0080-00 | | | 0.022 μ F | Cer | 25 V | +80%—20% |
| C1016 | 290-0248-01 | | | 150 μ F | Elect. | 15 V | |
| C1081 | 281-0064-00 | | | 0.2-1.5 pF, Var | Tub. | | |
| C1082 | 281-0537-00 | | | 0.68 pF | Cer | 500 V | |
| C1084 | 283-0079-00 | | | 0.01 μ F | Cer | 250 V | |
| C1091 | 281-0064-00 | | | 0.2-1.5 pF, Var | Tub. | | |
| C1092 | 281-0537-00 | | | 0.68 pF | Cer | 500 V | |
| C1101 | 285-0696-00 | | | 0.5 μ F | PMC | 600 V | 10% |
| C1105 | 283-0080-00 | | | 0.022 μ F | Cer | 25 V | +80%—20% |
| C1111 | 285-0566-00 | | | 0.022 μ F | PTM | 200 V | 10% |
| C1112 | 290-0313-00 | | | 2800 μ F | Elect. | 25 V | +75%—10% |
| C1116 | 290-0267-00 | | | 1 μ F | Elect. | 35 V | |
| C1127 | 283-0078-00 | | | 0.001 μ F | Cer | 500 V | |

Electrical Parts List—Type 454/R454

Capacitors (cont)

| Ckt. No. | Tektronix Part No. | Serial/Model No. | | Description | | | |
|----------|--------------------|------------------|----------|----------------|--------|-------|-----------|
| | | Eff | Disc | | | | |
| C1128 | 290-0162-00 | | | 22 μ F | Elect. | 35 V | |
| C1141 | 285-0566-00 | | | 0.022 μ F | PTM | 200 V | 10% |
| C1142 | 290-0313-00 | | | 2800 μ F | Elect. | 25 V | +75%—10% |
| C1153 | 283-0078-00 | | | 0.001 μ F | Cer | 500 V | |
| C1155 | 290-0286-00 | | | 50 μ F | Elect. | 25 V | +75%—10% |
| C1166 | 290-0162-00 | | | 22 μ F | Elect. | 35 V | |
| C1171 | 285-0566-00 | | | 0.022 μ F | PTM | 200 V | 10% |
| C1172 | 290-0280-00 | | | 200 μ F | Elect. | 150 V | |
| C1184 | 283-0092-00 | | | 0.03 μ F | Cer | 200 V | +80%—20% |
| C1192 | 283-0083-00 | | | 0.0047 μ F | Cer | 500 V | 5% |
| C1195 | 290-0305-00 | | | 3 μ F | Elect. | 150 V | |
| C1196 | 290-0198-00 | | | 17 μ F | Elect. | 150 V | +30%—15% |
| C1201 | 285-0566-00 | | | 0.022 μ F | PTM | 200 V | 10% |
| C1202 | 290-0280-00 | | | 200 μ F | Elect. | 150 V | |
| C1204 | 290-0314-00 | | | 10 μ F | Elect. | 100 V | +100%—10% |
| C1211 | 285-0566-00 | | | 0.022 μ F | PTM | 200 V | 10% |
| C1221 | 283-0092-00 | | | 0.03 μ F | Cer | 200 V | +80%—20% |
| C1222 | 283-0092-00 | | | 0.03 μ F | Cer | 200 V | +80%—20% |
| C1223 | 290-0267-00 | | | 1 μ F | Elect. | 35 V | |
| C1224 | 283-0081-00 | | | 0.1 μ F | Cer | 25 V | +80%—20% |
| C1225 | 290-0267-00 | | | 1 μ F | Elect. | 35 V | |
| C1226 | 283-0059-00 | XB050000 | | 1 μ F | Cer | 25 V | +80%—20% |
| C1227 | 283-0080-00 | | | 0.022 μ F | Cer | 25 V | +80%—20% |
| C1229 | 283-0080-00 | | | 0.022 μ F | Cer | 25 V | +80%—20% |
| C1230 | 283-0080-00 | | | 0.022 μ F | Cer | 25 V | +80%—20% |
| C1231 | 283-0080-00 | | | 0.022 μ F | Cer | 25 V | +80%—20% |
| C1232 | 283-0003-00 | | | 0.01 μ F | Cer | 500 V | |
| C1233 | 283-0003-00 | | | 0.01 μ F | Cer | 500 V | |
| C1234 | 283-0003-00 | | | 0.01 μ F | Cer | 500 V | |
| C1236 | 283-0003-00 | | | 0.01 μ F | Cer | 500 V | |
| C1246 | 290-0135-00 | | | 15 μ F | Elect. | 20 V | |
| C1248 | 290-0135-00 | | | 15 μ F | Elect. | 20 V | |
| C1249 | 283-0092-00 | | | 0.03 μ F | Cer | 200 V | +80%—20% |
| C1251 | 283-0067-00 | B010100 | B219999X | 0.001 μ F | Cer | 200 V | 10% |
| C1252 | 290-0267-00 | | | 1 μ F | Elect. | 35 V | |
| C1254 | 290-0267-00 | | | 1 μ F | Elect. | 35 V | |
| C1255 | 283-0081-00 | X220000 | | 0.1 μ F | Cer | 25 V | +80%—20% |
| C1256 | 283-0092-00 | | | 0.03 μ F | Cer | 200 V | +80%—20% |
| C1257 | 283-0080-00 | | | 0.022 μ F | Cer | 35 V | +80%—20% |
| C1258 | 283-0080-00 | | | 0.022 μ F | Cer | 35 V | +80%—20% |
| C1259 | 290-0267-00 | | | 1 μ F | Elect. | 35 V | |
| C1262 | 290-0267-00 | | | 1 μ F | Elect. | 35 V | |
| C1264 | 290-0267-00 | | | 1 μ F | Elect. | 35 V | |
| C1267 | 283-0080-00 | | | 0.22 μ F | Cer | 35 V | +80%—20% |
| C1269 | 290-0267-00 | | | 1 μ F | Elect. | 35 V | |

Capacitors (cont)

| Ckt. No. | Tektronix Part No. | Serial/Model No. | | Description | | |
|----------|--------------------|------------------|-----------------|-------------|---------|----------|
| | | Eff | Disc | | | |
| C1271 | 290-0267-00 | | 1 μ F | Elect. | 35 V | |
| C1275 | 285-0595-00 | | 0.1 μ F | PTM | 100 V | 1% |
| C1286 | 283-0010-00 | | 0.05 μ F | Cer | 50 V | |
| C1294 | 281-0518-00 | | 47 pF | Cer | 50 V | |
| C1303 | 283-0080-00 | | 0.022 μ F | Cer | 35 V | +80%—20% |
| C1311 | 283-0003-00 | | 0.01 μ F | Cer | 150 V | |
| C1316 | 283-0080-00 | | 0.022 μ F | Cer | 35 V | +80%—20% |
| C1321 | 283-0080-00 | | 0.022 μ F | Cer | 35 V | +80%—20% |
| C1322 | 281-0547-00 | | 2.7 pF | Cer | 500 V | 10% |
| C1324 | 283-0083-00 | | 0.0047 μ F | Cer | 500 V | 5% |
| C1326 | 283-0092-00 | | 0.03 μ F | Cer | 200 V | +80%—20% |
| C1333 | 283-0080-00 | | 0.022 μ F | Cer | 25 V | +80%—20% |
| C1346 | 283-0080-00 | | 0.022 μ F | Cer | 25 V | +80%—20% |
| C1351 | 281-0547-00 | | 2.7 pF | Cer | 500 V | 10% |
| C1352 | 281-0064-00 | | 0.2-1.5 pF, Var | Tub. | | |
| C1353 | 283-0092-00 | | 0.03 μ F | Cer | 200 V | +80%—20% |
| C1355 | 283-0092-00 | | 0.03 μ F | Cer | 200 V | +80%—20% |
| C1358 | 283-0092-00 | | 0.03 μ F | Cer | 200 V | +80%—20% |
| C1402 | 285-0703-00 | | 0.1 μ F | PTM | 100 V | 5% |
| C1403 | 290-0159-00 | | 2 μ F | Elect. | 150 V | |
| C1408 | 283-0044-00 | | 0.001 μ F | Cer | 3000 V | |
| C1419 | 285-0622-00 | | 0.1 μ F | PTM | 100 V | |
| C1437 | 290-0312-00 | | 47 μ F | Elect. | 35 V | 10% |
| C1440 | 283-0120-00 | | 0.015 μ F | Cer | 2500 V | +80%—30% |
| C1449 | 283-0120-00 | | 0.015 μ F | Cer | 2500 V | +80%—30% |
| C1452 | 283-0120-00 | | 0.015 μ F | Cer | 2500 V | +80%—30% |
| C1453 | 283-0021-00 | | 0.001 μ F | Cer | 5000 V | |
| C1455 | 281-0556-00 | | 500 pF | Cer | 10000 V | |
| C1457 | 281-0556-00 | | 500 pF | Cer | 10000 V | |
| C1460 | 283-0096-00 | | 500 pF | Cer | 20000 V | |
| C1469 | 283-0120-00 | | 0.015 μ F | Cer | 2500 V | +80%—30% |
| C1472 | 283-0092-00 | | 0.03 μ F | Cer | 200 V | +80%—20% |
| C1477 | 283-0120-00 | | 0.015 μ F | Cer | 2500 V | +80%—30% |
| C1479 | 281-0525-00 | | 470 pF | Cer | 500 V | |
| C1482 | 283-0003-00 | | 0.01 μ F | Cer | 150 V | |
| C1489 | 283-0092-00 | | 0.03 μ F | Cer | 200 V | +80%—20% |

Diodes

| | | | |
|-----|--------------|---------|-------------------------|
| D13 | 152-0166-00 | Zener | 1N753A 0.4 W, 6.2 V, 5% |
| D14 | *152-0185-00 | Silicon | Replaceable by 1N4152 |
| D16 | *152-0185-00 | Silicon | Replaceable by 1N4152 |
| D17 | *152-0185-00 | Silicon | Replaceable by 1N4152 |
| D18 | *152-0185-00 | Silicon | Replaceable by 1N4152 |

Electrical Parts List—Type 454/R454

Diodes (cont)

| Ckt. No. | Tektronix Part No. | Serial/Model No. Eff | Disc | Description |
|----------|--------------------|----------------------|---------|----------------------------------|
| D32 | *152-0153-00 | | | Silicon Replaceable by 1N4244 |
| D36 | *152-0185-00 | | | Silicon Replaceable by 1N4152 |
| D44 | 152-0217-00 | | | Zener 1N756A 0.4 W, 8.2 V, 5% |
| D47 | 152-0141-00 | B010100 | B189999 | Silicon 1N4152 |
| D47 | 152-0141-02 | B190000 | | Silicon 1N4152 |
| D113 | 152-0166-00 | | | Zener 1N753A 0.4 W, 6.2 V, 5% |
| D114 | *152-0185-00 | | | Silicon Replaceable by 1N4152 |
| D116 | *152-0185-00 | | | Silicon Replaceable by 1N4152 |
| D117 | *152-0185-00 | | | Silicon Replaceable by 1N4152 |
| D118 | *152-0185-00 | | | Silicon Replaceable by 1N4152 |
| D132 | *152-0153-00 | | | Silicon Replaceable by 1N4244 |
| D136 | *152-0185-00 | | | Silicon Replaceable by 1N4152 |
| D144 | 152-0217-00 | | | Zener 1N756A 0.4 W, 8.2 V, 5% |
| D147 | 152-0141-00 | B010100 | B189999 | Silicon 1N4152 |
| D147 | 152-0141-02 | B190000 | | Silicon 1N4152 |
| D201 | *152-0153-00 | | | Silicon Replaceable by 1N4244 |
| D202 | *152-0153-00 | | | Silicon Replaceable by 1N4244 |
| D203 | *152-0153-00 | | | Silicon Replaceable by 1N4244 |
| D204 | *152-0153-00 | | | Silicon Replaceable by 1N4244 |
| D206 | *152-0153-00 | | | Silicon Replaceable by 1N4244 |
| D207 | *152-0153-00 | | | Silicon Replaceable by 1N4244 |
| D208 | *152-0153-00 | | | Silicon Replaceable by 1N4244 |
| D209 | *152-0153-00 | | | Silicon Replaceable by 1N4244 |
| D212 | *152-0185-00 | | | Silicon Replaceable by 1N4152 |
| D218 | 152-0141-00 | B010100 | B189999 | Silicon 1N4152 |
| D218 | 152-0141-02 | B190000 | | Silicon 1N4152 |
| D222 | *152-0185-00 | | | Silicon Replaceable by 1N4152 |
| D228 | 152-0141-00 | B010100 | B189999 | Silicon 1N4152 |
| D228 | 152-0141-02 | B190000 | | Silicon 1N4152 |
| D234 | *152-0185-00 | | | Silicon Replaceable by 1N4152 |
| D237 | *152-0185-00 | | | Silicon Replaceable by 1N4152 |
| D238 | *152-0185-00 | | | Silicon Replaceable by 1N4152 |
| D316 | 152-0166-00 | | | Zener 1N753A 0.4 W, 6.2 V, 5% |
| D323 | *152-0185-00 | | | Silicon Replaceable by 1N4152 |
| D324 | *152-0185-00 | | | Silicon Replaceable by 1N4152 |
| D325 | *152-0185-00 | | | Silicon Replaceable by 1N4152 |
| D339 | 152-0166-00 | | | Zener 1N753A 0.4 W, 6.2 V, 5% |
| D363 | 152-0195-00 | | | Zener 1N751A 0.4 W, 5.1 V, 5% |
| D388 | 152-0278-00 | XB170000 | | Zener 1N4372A 0.4 W, 3 V, 5% |
| D416 | 152-0166-00 | | | Zener 1N753A 0.4 W, 6.2 V, 5% |
| D423 | *152-0185-00 | | | Silicon Replaceable by 1N4152 |
| D424 | *152-0185-00 | | | Silicon Replaceable by 1N4152 |
| D425 | *152-0185-00 | | | Silicon Replaceable by 1N4152 |
| D463 | 152-0195-00 | | | Zener 1N751A 0.4 W, 5.1 V, 5% |
| D516 | *152-0153-00 | | | Silicon Replaceable by 1N4244 |

Diodes (cont)

| Kct. No. | Tektronix Part No. | Serial/Model No. Eff | Disc | | Description |
|----------|--------------------|----------------------|----------|---------|--|
| D521 | 152-0166-00 | | | Zener | 1N753A 0.4 W, 6.2 V, 5% |
| D543 | 152-0104-00 | B010100 | B159999 | Zener | 1N3016A 1 W, 6.8 V, 10% |
| D543 | 152-0290-00 | B160000 | | Zener | 1N3016B 1 W, 6.8 V, 5% |
| D636 | *152-0185-00 | | | Silicon | Replaceable by 1N4152 |
| D638 | *152-0185-00 | | | Silicon | Replaceable by 1N4152 |
| D641 | 152-0076-00 | B010100 | B159999 | Zener | 1N4372 0.4 W, 3 V, 10% |
| D641 | 152-0278-00 | B160000 | | Zener | 1N4372A 0.4 W, 3 V, 5% |
| D642 | 152-0076-00 | B010100 | B159999 | Zener | 1N4372 0.4 W, 3 V, 10% |
| D642 | 152-0278-00 | B160000 | | Zener | 1N4372A 0.4 W, 3 V, 5% |
| D651 | *152-0185-00 | | | Silicon | Replaceable by 1N4152 |
| D652 | *152-0185-00 | | | Silicon | Replaceable by 1N4152 |
| D654 | *152-0153-00 | | | Silicon | Replaceable by 1N4244 |
| D655 | *152-0153-00 | | | Silicon | Replaceable by 1N4244 |
| D657 | *152-0310-00 | | | Tunnel | Replaceable by 1N3758 5 mA \pm 1 mA |
| D671 | *152-0153-00 | | | Silicon | Replaceable by 1N4244 |
| D680 | *152-0153-00 | B010100 | B219999X | Silicon | Replaceable by 1N4244 |
| D681 | *152-0153-00 | | | Silicon | Replaceable by 1N4244 |
| D687 | *152-0185-00 | | | Silicon | Replaceable by 1N4152 |
| D692 | *152-0185-00 | | | Silicon | Replaceable by 1N4152 |
| D701 | *152-0153-00 | | | Silicon | Replaceable by 1N4244 |
| D702 | *152-0310-00 | B010100 | B219999 | Tunnel | Replaceable by 1N3758 5 mA \pm 1 mA |
| D702 | 152-0125-00 | B220000 | | Tunnel | TD 3A, 4.7 mA |
| D707 | *152-0153-00 | | | Silicon | Replaceable by 1N4244 |
| D710 | *152-0185-00 | | | Silicon | Replaceable by 1N4152 |
| D715 | *152-0153-00 | | | Silicon | Replaceable by 1N4244 |
| D717 | *152-0153-00 | | | Silicon | Replaceable by 1N4244 |
| D721 | *152-0185-00 | | | Silicon | Replaceable by 1N4152 |
| D726 | *152-0185-00 | | | Silicon | Replaceable by 1N4152 |
| D732 | *152-0185-00 | | | Silicon | Replaceable by 1N4152 |
| D733 | *152-0165-00 | XB110000 | B129999 | Silicon | Selected from 1N3579 |
| D733 | 152-0323-00 | B130000 | | Silicon | Tek Spec |
| D735 | *152-0185-00 | | | Silicon | Replaceable by 1N4152 |
| D739 | *152-0185-00 | XB270000 | | Silicon | Replaceable by 1N4152 |
| D749 | *152-0185-00 | | | Silicon | Replaceable by 1N4152 |
| D750 | *152-0185-00 | | | Silicon | Replaceable by 1N4152 |
| D757A,B | *152-0151-00 | | | Silicon | Matched pair of 1N4152 |
| D759 | *152-0185-00 | | | Silicon | Replaceable by 1N4152 |
| D760 | *152-0185-00 | | | Silicon | Replaceable by 1N4152 |
| D761 | *152-0185-00 | | | Silicon | Replaceable by 1N4152 |
| D763 | *152-0185-00 | | | Silicon | Replaceable by 1N4152 |
| D766 | 152-0217-00 | | | Zener | 1N756A 0.4 W, 8.2 V, 5% |
| D769 | *152-0185-00 | | | Silicon | Replaceable by 1N4152 |
| D770 | *152-0185-00 | | | Silicon | Replaceable by 1N4152 |
| D772 | *152-0185-00 | | | Silicon | Replaceable by 1N4152 |
| D773 | *152-0185-00 | | | Silicon | Replaceable by 1N4152 |
| D793 | *152-0185-00 | | | Silicon | Replaceable by 1N4152 |

Electrical Parts List—Type 454/R454

Diodes (cont)

| Ckt. No. | Tektronix Part No. | Serial/Model No. Eff | Disc | Description |
|----------|--------------------|----------------------|---------|---|
| D794 | *152-0185-00 | | | Silicon Replaceable by 1N4152 |
| D795 | *152-0185-00 | | | Silicon Replaceable by 1N4152 |
| D796 | *152-0185-00 | | | Silicon Replaceable by 1N4152 |
| D797 | *152-0185-00 | | | Silicon Replaceable by 1N4152 |
| D828 | *152-0185-00 | | | Silicon Replaceable by 1N4152 |
| D833 | *152-0185-00 | | | Silicon Replaceable by 1N4152 |
| D836 | *152-0185-00 | | | Silicon Replaceable by 1N4152 |
| D838 | *152-0185-00 | | | Silicon Replaceable by 1N4152 |
| D841 | 152-0076-00 | B010100 | B159999 | Zener 1N4372 0.4 W, 3 V, 10% |
| D841 | 152-0278-00 | B160000 | | Zener 1N4372A 0.4 W, 3 V, 5% |
| D842 | 152-0076-00 | B010100 | B159999 | Zener 1N4372 0.4 W, 3 V, 10% |
| D842 | 152-0278-00 | B160000 | | Zener 1N4372A 0.4 W, 3 V, 5% |
| D851 | *152-0185-00 | | | Silicon Replaceable by 1N4152 |
| D852 | *152-0185-00 | | | Silicon Replaceable by 1N4152 |
| D854 | *152-0153-00 | | | Silicon Replaceable by 1N4244 |
| D855 | *152-0153-00 | | | Silicon Replaceable by 1N4244 |
| D857 | *152-0310-00 | | | Tunnel Replaceable by 1N3758 5 mA \pm 1 mA |
| D871 | *152-0153-00 | | | Silicon Replaceable by 1N4244 |
| D901 | *152-0153-00 | | | Silicon Replaceable by 1N4244 |
| D902 | *152-0310-00 | | | Tunnel Replaceable by 1N3758 5 mA \pm 1 mA |
| D907 | *152-0153-00 | | | Silicon Replaceable by 1N4244 |
| D918 | *152-0153-00 | | | Silicon Replaceable by 1N4244 |
| D919 | *152-0153-00 | | | Silicon Replaceable by 1N4244 |
| D926 | *152-0185-00 | | | Silicon Replaceable by 1N4152 |
| D933 | *152-0165-00 | XB110000 | B129999 | Silicon Selected from 1N3579 |
| D933 | *152-0323-00 | B130000 | | Silicon Tek Spec |
| D935 | *152-0185-00 | | | Silicon Replaceable by 1N4152 |
| D939 | *152-0185-00 | | | Silicon Replaceable by 1N4152 |
| D948 | *152-0185-00 | | | Silicon Replaceable by 1N4152 |
| D949 | *152-0185-00 | | | Silicon Replaceable by 1N4152 |
| D950 | *150-0185-00 | | | Silicon Replaceable by 1N4152 |
| D952 | *152-0185-00 | | | Silicon Replaceable by 1N4152 |
| D964 | *152-0075-00 | XB090000 | | Germanium Tek Spec |
| D965 | *152-0185-00 | | | Silicon Replaceable by 1N4152 |
| D976 | *152-0185-00 | | | Silicon Replaceable by 1N4152 |
| D977 | *152-0185-00 | | | Silicon Replaceable by 1N4152 |
| D987 | *152-0185-00 | | | Silicon Replaceable by 1N4152 |
| D988 | *152-0185-00 | | | Silicon Replaceable by 1N4152 |
| D989 | *152-0185-00 | | | Silicon Replaceable by 1N4152 |
| D995A,B | *152-0151-00 | | | Silicon Matched pair of 1N4152 |
| D1035 | *152-0185-00 | | | Silicon Replaceable by 1N4152 |
| D1045 | *152-0185-00 | | | Silicon Replaceable by 1N4152 |
| D1054 | *152-0153-00 | | | Silicon Replaceable by 1N4244 |
| D1055 | *152-0153-00 | | | Silicon Replaceable by 1N4244 |
| D1084 | *152-0061-00 | | | Silicon Tek Spec |

Diodes (cont)

| Kct. No. | Tektronix Part No. | Serial/Model No. Eff | No. Disc | | Description |
|------------------|--------------------|----------------------|----------|---------|-------------------------|
| D1112A,B,C,D (4) | *152-0198-00 | | | Silicon | Replaceable by MPS-918 |
| D1116 | 152-0212-00 | | | Zener | 1N936 9 V, 5%, TC |
| D1120 | *152-0185-00 | | | Silicon | Replaceable by 1N4152 |
| D1125 | 152-0066-00 | | | Silicon | 1N3194 |
| D1142A,B,C,D (4) | *152-0198-00 | | | Silicon | Replaceable by MPS-918 |
| D1154 | *152-0185-00 | | | Silicon | Replaceable by 1N4152 |
| D1158 | *152-0185-00 | | | Silicon | Replaceable by 1N4152 |
| D1159 | *152-0185-00 | | | Silicon | Replaceable by 1N4152 |
| D1172A,B,C,D (4) | 152-0066-00 | | | Silicon | 1N3194 |
| D1182 | 152-0142-00 | B010100 | B159999 | Zener | 1N972A 0.4 W, 30 V, 10% |
| D1182 | 152-0282-00 | B160000 | | Zener | 1N972B 0.4 W, 30 V, 5% |
| D1184 | 152-0268-00 | | | Zener | 1N979B 0.4 W, 56 V, 5% |
| D1185 | *152-0185-00 | | | Silicon | Replaceable by 1N4152 |
| D1189 | *152-0185-00 | | | Silicon | Replaceable by 1N4152 |
| D1190 | 152-0195-00 | | | Zener | 1N751A 0.4 W, 5.1 V, 5% |
| D1193 | *152-0185-00 | | | Silicon | Replaceable by 1N4152 |
| D1196 | 152-0066-00 | | | Silicon | 1N3194 |
| D1202 | 152-0066-00 | | | Silicon | 1N3194 |
| D1212 | 152-0066-00 | | | Silicon | 1N3194 |
| D1228 | 152-0212-00 | | | Zener | 1N936 9 V, 5%, TC |
| D1249 | 152-0064-00 | B010100 | B159999 | Zener | 1N961A 0.4 W, 10 V, 10% |
| D1249 | 152-0149-00 | B160000 | | Zener | 1N961B 0.4 W, 10 V, 5% |
| D1314 | *152-0153-00 | | | Silicon | Replaceable by 1N4244 |
| D1318 | *152-0153-00 | | | Silicon | Replaceable by 1N4244 |
| D1326 | *152-0107-00 | | | Silicon | Replaceable by 1N647 |
| D1343 | *152-0185-00 | | | Silicon | Replaceable by 1N4152 |
| D1353 | *152-0107-00 | | | Silicon | Replaceable by 1N647 |
| D1355 | *152-0061-00 | | | Silicon | Tek Spec |
| D1356 | 152-0126-00 | B010100 | B159999 | Zener | 1N3024A 1 W, 15 V, 10% |
| D1356 | 152-0024-00 | B160000 | | Zener | 1N3024B 1 W, 15 V, 5% |
| D1357 | *152-0061-00 | | | Silicon | Tek Spec |
| D1404 | *152-0185-00 | | | Silicon | Replaceable by 1N4152 |
| D1440 | *152-0192-00 | | | Silicon | Replaceable by MPS-6521 |
| D1452 | *152-0192-00 | | | Silicon | Replaceable by MPS-6521 |
| D1453 | 152-0218-00 | B010100 | B229999 | Silicon | 10,000 Volts 20 mA |
| D1453 | 152-0408-00 | B230000 | | Silicon | 10,000 Volts 5 mA |
| D1455 | 152-0218-00 | B010100 | B229999 | Silicon | 10,000 Volts 20 mA |
| D1455 | 152-0408-00 | B230000 | | Silicon | 10,000 Volts 5 mA |
| D1457 | 152-0218-00 | B010100 | B229999 | Silicon | 10,000 Volts 20 mA |
| D1457 | 152-0408-00 | B230000 | | Silicon | 10,000 Volts 5 mA |

Fuses

| | | | | |
|-------|-------------|--|--|-------------------|
| F1101 | 159-0021-00 | | | 2A 3AG Fast-Bl |
| F1102 | 159-0022-00 | | | 1A 3AG Fast-Bl |
| F1204 | 159-0028-00 | | | 0.25A 3AG Fast-Bl |
| F1437 | 159-0021-00 | | | 2A 3AG Fast-Bl |

Electrical Parts List—Type 454/R454

Connectors

| Ckt. No. | Tektronix Part No. | Serial/Model No. Eff | No. Disc | Description |
|----------|--------------------|----------------------|----------|-------------------------------|
| J1 | 131-0352-00 | | | BNC |
| J101 | 131-0352-00 | | | BNC |
| J501 | 131-0352-01 | | | BNC, Receptacle |
| J601 | 131-0352-01 | | | BNC, Receptacle |
| J729 | 131-0352-01 | | | BNC, Receptacle |
| J750 | 131-0352-01 | | | BNC, Receptacle |
| J801 | 131-0352-01 | | | BNC, Receptacle |
| J929 | 131-0352-01 | | | BNC, Receptacle |
| J1238 | 131-0438-00 | B010100 | B139999 | 3 contact, female |
| J1238 | 131-0438-01 | B140000 | | 3 contact, female, Receptacle |
| J1239 | 131-0438-00 | B010100 | B139999 | 3 contact, female |
| J1239 | 131-0438-01 | B140000 | | 3 contact, female, Receptacle |
| J1299 | 131-0352-01 | | | BNC, Receptacle |

Relays

| | | | | |
|--------|--------------|--|--|---------------------------------------|
| K442 | *108-0431-00 | | | Coil, Reed (Typical resistance 215 Ω) |
| K442-A | 260-0839-00 | | | Reed |

Inductors

| | | | | |
|-------------------|--------------|----------|----------|---------------------------|
| L5D | *108-0456-00 | | | 43 nH |
| L6A | *108-0455-00 | B010100 | B039999 | 40 nH |
| L6A | *108-0373-00 | B040000 | | 56 nH |
| L23 | 276-0507-00 | | | Core, Ferramic Suppressor |
| L37 | 276-0507-00 | | | Core, Ferramic Suppressor |
| L44 | *108-0262-01 | | | 0.6 μH |
| L64 ^a | *388-0839-00 | | | T Coil |
| L81 | 276-0528-00 | | | Core, Ferramic Suppressor |
| L91 | 276-0528-00 | | | Core, Ferramic Suppressor |
| L105D | *108-0456-00 | | | 43 nH |
| L106A | *108-0455-00 | B010100 | B039999 | 40 nH |
| L106A | *108-0373-00 | B040000 | | 56 nH |
| L123 | 276-0507-00 | | | Core, Ferramic Suppressor |
| L137 | 276-0507-00 | | | Core, Ferramic Suppressor |
| L144 | *108-0262-01 | | | 0.6 μH |
| L164 ^a | *388-0839-00 | | | T Coil |
| L174 | 276-0543-00 | XB080000 | B139999X | Core, Ferrite |
| L181 | 276-0528-00 | | | Core, Ferramic Suppressor |
| L191 | 276-0528-00 | | | Core, Ferramic Suppressor |
| L202 | 276-0528-00 | | | Core, Ferramic Suppressor |
| L203 | 276-0528-00 | | | Core, Ferramic Suppressor |
| L207 | 276-0528-00 | | | Core, Ferramic Suppressor |
| L208 | 276-0528-00 | | | Core, Ferramic Suppressor |

^aFurnished as a unit with C64.

^aFurnished as a unit with C164.

Inductors (cont)

| Ckt. No. | Tektronix Part No. | Serial/Model No. Eff | Disc | Description |
|--------------------|--------------------|----------------------|---------|------------------------------------|
| L215 | 276-0528-00 | | | Core, Ferramic Suppressor |
| L225 | 276-0528-00 | | | Core, Ferramic Suppressor |
| L301 ¹⁰ | | | | |
| L302 | *108 0444-00 | | | 30 nH |
| L303 ¹⁰ | | | | |
| L305 ¹⁰ | | | | |
| L306 | *108-0444-00 | | | 30 nH |
| L308 | *108-0182-00 | | | 0.3 μH |
| L318 | *108-0170-01 | | | 0.5 μH |
| L337 ¹¹ | *388-0867-00 | | | T Coil, 4T |
| L343 | *108-0440-00 | | | Toroid, 4T |
| L350 | *119-0169-01 | XB270000 | | Delay Line Assembly |
| L368 ¹² | *388-0868-00 | | | T Coil, 3T |
| L385 | *108-0440-00 | | | Toroid, 4T |
| L394 | *114-0232-00 | | | 0.13-0.22 μH, Var Core 276-0568-00 |
| L401 ¹⁰ | | | | |
| L403 ¹⁰ | | | | |
| L404 | *108-0444-00 | | | 30 nH |
| L405 ¹⁰ | | | | |
| L408 | *108-0182-00 | | | 0.3 μH |
| L418 | *108-0170-01 | | | 0.5 μH |
| L437 ¹³ | *388-0867-00 | | | T Coil, 4T |
| L468 ¹⁴ | *388-0868-00 | | | T Coil, 3T |
| L494 | *114-0232-00 | | | 0.13-0.22 μH, Var Core 276-0568-00 |
| L501 | 276-0554-00 | XB270000 | | Core, Toroid Ferrite |
| L504 | 276-0554-00 | XB270000 | | Core, Toroid Ferrite |
| L512 | *108-0440-00 | | | Toroid, 4T |
| L521 | 276-0507-00 | | | Core, Ferramic Suppressor |
| L551 | *108-0426-00 | | | 210 nH |
| L555 | *108-0426-00 | | | 210 nH |
| L568 | *114-0229-00 | | | 2.2-4.4 μH, Var Core 276-0506-00 |
| L656 | *108-0306-00 | XB060000 | B209999 | 0.09 μH |
| L656 | *108-0508-00 | B210000 | | 0.09 μH |
| L759 | 276-0528-00 | XB240000 | | Core, Ferramic Suppressor |
| L664 | *108-0306-00 | B010100 | B059999 | 0.09 μH |
| L664 | *108-0475-00 | B060000 | | 0.09 μH w/tap |
| L687 | 276-0528-00 | XB070000 | | Core, Ferramic Suppressor |
| L735 | 276-0507-00 | | | Core, Ferramic Suppressor |
| L759 | 276-0528-00 | XB240000 | | Core, Ferramic Suppressor |
| L836 | 276-0507-00 | XB260000 | | Core, Ferramic Suppressor |
| L838 | 276-0507-00 | XB260000 | | Core, Ferramic Suppressor |
| L856 | *108-0306-00 | XB060000 | B209999 | 0.09 μH |
| L856 | *108-0508-00 | B210000 | | 0.09 μH |
| L864 | *108-0306-00 | B010100 | B059999 | 0.09 μH |
| L864 | *108-0475-00 | B060000 | | 0.09 μH w/tap |
| L935 | 276-0507-00 | | | Core, Ferramic Suppressor |
| L1084 | 108-0254-00 | | | 600 μH |
| L1094 | 108-0254-00 | | | 600 μH |
| L1223 | *108-0440-00 | | | Toroid, 4T |
| L1225 | *108-0440-00 | | | Toroid, 4T |

¹⁰Part of Vertical Output Board.

¹¹Furnished as a unit with C337.

¹²Furnished as a unit with C368.

¹³Furnished as a unit with C437.

¹⁴Furnished as a unit with C468.

Electrical Parts List—Type 454/R454

Inductors (cont)

| Ckt. No. | Tektronix Part No. | Serial/Model No. Eff | No. Disc | Description |
|----------|--------------------|----------------------|----------|--|
| L1227 | *108-0440-00 | | | Toroid, 4T |
| L1229 | *108-0440-00 | | | Toroid, 4T |
| L1230 | *108-0440-00 | | | Toroid, 4T |
| L1231 | *108-0440-00 | | | Toroid, 4T |
| L1232 | *108-0440-00 | | | Toroid, 4T |
| L1233 | *108-0440-00 | | | Toroid, 4T |
| L1234 | *108-0440-00 | | | Toroid, 4T |
| L1235 | *108-0440-00 | | | Toroid, 4T |
| L1236 | *108-0440-00 | | | Toroid, 4T |
| L1238 | *120-0398-00 | | | Toroid, 15T |
| L1239 | *120-0398-00 | | | Toroid, 15T |
| L1246 | 276-0507-00 | | | Core, Ferramic Suppressor |
| L1248 | 276-0507-00 | | | Core, Ferramic Suppressor |
| L1269 | 276-0507-00 | | | Core, Ferramic Suppressor |
| L1437 | *108-0422-00 | | | 80 μ H |
| L1480 | *108-0321-00 | | | Trace Rotation |
| L1485 | *108-0295-00 | | | Y-Axis Alignment |
| LR49B | *108-0453-00 | | | 29 nH |
| LR149B | *108-0453-00 | | | 29 nH |
| LR318 | *108-0430-00 | | | 0.88 μ H (wound on a 68 Ω resistor) |
| LR319 | *108-0445-00 | | | 0.6 μ H (wound on a 91 Ω resistor) |
| LR418 | *108-0429-00 | | | 1.2 μ H (wound on a 47 Ω resistor) |
| LR419 | *108-0428-00 | | | 4.2 μ H (wound on a 33 Ω resistor) |
| LR518 | *108-0466-00 | | | 0.9 μ H (wound on a 27 Ω resistor) |
| LR696 | *108-0491-00 | XB070000 | | 25 μ H (wound on a 180 Ω resistor) |

Transistors

| | | | | | |
|------|--------------|---------|---------|---------|----------------------|
| Q24 | *151-0193-00 | | | Silicon | Tek Spec |
| Q34 | *151-0193-00 | | | Silicon | Tek Spec |
| Q38 | *151-0109-00 | | | Silicon | Selected from 2N918 |
| Q44 | 151-0202-00 | | | Silicon | 2N4261 |
| Q54 | 151-0202-00 | | | Silicon | 2N4261 |
| Q64 | *151-0212-00 | | | Silicon | Tek Spec |
| Q74 | *151-0212-00 | | | Silicon | Tek Spec |
| Q84 | 151-0202-00 | | | Silicon | 2N4261 |
| Q94 | 151-0202-00 | | | Silicon | 2N4261 |
| Q124 | *151-0193-00 | | | Silicon | Tek Spec |
| Q134 | *151-0193-00 | | | Silicon | Tek Spec |
| Q138 | *151-0109-00 | | | Silicon | Selected from 2N918 |
| Q144 | 151-0202-00 | | | Silicon | 2N4261 |
| Q164 | *151-0212-00 | | | Silicon | Tek Spec |
| Q174 | *151-0212-00 | | | Silicon | Tek Spec |
| Q184 | 151-0202-00 | | | Silicon | 2N4261 |
| Q194 | 151-0202-00 | | | Silicon | 2N4261 |
| Q215 | 151-0223-00 | B010100 | B209999 | Silicon | 2N4275 |
| Q215 | *151-0190-01 | B210000 | | Silicon | Tek Spec |
| Q225 | 151-0223-00 | B010100 | B209999 | Silicon | 2N4275 |
| Q225 | *151-0190-01 | B210000 | | Silicon | Tek Spec |
| Q234 | 151-0223-00 | | | Silicon | 2N4275 |
| Q244 | 151-0223-00 | | | Silicon | 2N4275 |
| Q253 | 151-0220-00 | | | Silicon | 2N4122 |
| Q274 | *151-0222-00 | | | Silicon | Selected from 2N4251 |
| Q284 | *151-0222-00 | | | Silicon | Selected from 2N4251 |
| Q314 | *151-0222-00 | | | Silicon | Selected from 2N4251 |

Transistors (cont)

| Ckt. No. | Tektronix Part No. | Serial/Model No. | | | Description |
|----------|--------------------|------------------|---------|---------|----------------------|
| | | Eff | Disc | | |
| Q324 | 151-0202-00 | | | Silicon | 2N4261 |
| Q334 | 151-0202-00 | | | Silicon | 2N4261 |
| Q354 | *151-0222-00 | | | Silicon | Selected from 2N4251 |
| Q364 | *151-0193-00 | | | Silicon | Tek Spec |
| Q374 | *151-0213-00 | | | Silicon | Selected from 2N4251 |
| Q394 | *151-0211-00 | | | Silicon | Selected from 2N3866 |
| Q388 | 151-0220-00 | | | Silicon | 2N4122 |
| Q414 | *151-0222-00 | | | Silicon | Selected from 2N4251 |
| Q424 | 151-0202-00 | | | Silicon | 2N4261 |
| Q434 | 151-0202-00 | | | Silicon | 2N4261 |
| Q454 | *151-0222-00 | | | Silicon | Selected from 2N4251 |
| Q464 | *151-0193-00 | | | Silicon | Tek Spec |
| Q474 | *151-0213-00 | | | Silicon | Selected from 2N4251 |
| Q494 | *151-0211-00 | | | Silicon | Selected from 2N3866 |
| Q514 | *151-0212-00 | | | Silicon | Tek Spec |
| Q524 | 151-0202-00 | | | Silicon | 2N4261 |
| Q534 | *151-0142-00 | | | Silicon | Selected from 2N3546 |
| Q544 | *151-0222-00 | | | Silicon | Selected from 2N4251 |
| Q636 | *151-0109-00 | B010100 | B069999 | Silicon | Selected from 2N918 |
| Q636 | *151-0127-00 | B070000 | B219999 | Silicon | Selected from 2N2369 |
| Q636 | 151-0223-00 | B22000 | | Silicon | 2N4275 |
| Q646 | *151-0109-00 | B010100 | B069999 | Silicon | Selected from 2N918 |
| Q646 | *151-0127-00 | B070000 | B219999 | Silicon | Selected from 2N2369 |
| Q646 | 151-0223-00 | B220000 | | Silicon | 2N4275 |
| Q664 | 151-0220-00 | | | Silicon | 2N4122 |
| Q667 | 151-0199-00 | XB220000 | | Silicon | MPS-3640 |
| Q670 | 151-0199-00 | XB220000 | | Silicon | MPS-3640 |
| Q674 | *151-0109-00 | B010100 | B219999 | Silicon | Selected from 2N918 |
| Q674 | *151-0212-00 | B220000 | | Silicon | Tek Spec |
| Q685 | 151-0223-00 | B010100 | B069999 | Silicon | 2N4275 |
| Q685 | *151-0212-00 | B070000 | B219999 | Silicon | Tek Spec |
| Q685 | 151-0223-00 | B220000 | | Silicon | 2N4275 |
| Q694 | 151-0220-00 | | | Silicon | 2N4122 |
| Q695 | 151-0223-00 | | | Silicon | 2N4275 |
| Q704 | 151-0131-00 | | | Silicon | 2N964 |
| Q714 | 151-0224-00 | | | Silicon | 2N3692 |
| Q716 | 151-0223-00 | | | Silicon | 2N4275 |
| Q724 | *153-0546-00 | | | Silicon | 2N929, Selected |
| Q726 | 151-0224-00 | | | Silicon | 2N3692 |
| Q734 | *151-0127-00 | | | Silicon | Selected from 2N2369 |
| Q744 | *151-0133-00 | | | Silicon | Selected from 2N3251 |
| Q753A | 151-0220-00 | | | Silicon | 2N4122 |
| Q753B | 151-0220-00 | | | Silicon | 2N4122 |
| Q754 | *151-0133-00 | | | Silicon | Selected from 2N3251 |
| Q764 | 151-0224-00 | | | Silicon | 2N3692 |
| Q774 | *151-0133-00 | | | Silicon | Selected from 2N3251 |
| Q775 | *151-0133-00 | | | Silicon | Selected from 2N3251 |
| Q784 | 151-0223-00 | | | Silicon | 2N4275 |
| Q785 | 151-0220-00 | | | Silicon | 2N4122 |
| Q786 | 151-0223-00 | | | Silicon | 2N4275 |

Electrical Parts List—Type 454/R454

Transistors (cont)

| Kct. No. | Tektronix Part No. | Serial/Model No. Eff | No. Disc | | Description |
|----------|--------------------|----------------------|----------|---------|-----------------------|
| Q794 | *151-0136-00 | | | Silicon | Replaceable by 2N3053 |
| Q836 | *151-0109-00 | B010100 | B069999 | Silicon | Selected from 2N918 |
| Q836 | *151-0127-00 | B070000 | | Silicon | Selected from 2N2369 |
| Q846 | *151-0109-00 | B010100 | B069999 | Silicon | Selected from 2N918 |
| Q846 | *151-0127-00 | B070000 | | Silicon | Selected from 2N2369 |
| Q864 | 151-0220-00 | | | Silicon | 2N4122 |
| Q904 | 151-0131-00 | | | Silicon | 2N964 |
| Q916 | 151-0223-00 | | | Silicon | 2N4275 |
| Q924 | *153-0546-00 | | | Silicon | 2N929, Selected |
| Q926 | 151-0224-00 | | | Silicon | 2N3692 |
| Q934 | *151-0127-00 | | | Silicon | Selected from 2N2369 |
| Q944 | *151-0133-00 | | | Silicon | Selected from 2N3251 |
| Q953A | 151-0220-00 | | | Silicon | 2N4122 |
| Q953B | 151-0220-00 | | | Silicon | 2N4122 |
| Q964 | 151-0223-00 | | | Silicon | 2N4275 |
| Q965 | *151-0133-00 | | | Silicon | Selected from 2N3251 |
| Q975 | *151-0133-00 | | | Silicon | Selected from 2N3251 |
| Q985 | 151-0220-00 | | | Silicon | 2N4122 |
| Q995 | 151-0220-00 | | | Silicon | 2N4122 |
| Q996 | *151-0104-00 | | | Silicon | Replaceable by 2N2919 |
| Q998 | 151-0224-00 | | | Silicon | 2N3692 |
| Q1014 | *151-0127-00 | | | Silicon | Selected from 2N2369 |
| Q1024 | *151-0127-00 | | | Silicon | Selected from 2N2369 |
| Q1034 | 151-0220-00 | | | Silicon | 2N4122 |
| Q1044 | 151-0220-00 | | | Silicon | 2N4122 |
| Q1058 | 151-0220-00 | | | Silicon | 2N4122 |
| Q1060 | 151-0220-00 | | | Silicon | 2N4122 |
| Q1063 | 151-0220-00 | | | Silicon | 2N4122 |
| Q1068 | 151-0220-00 | | | Silicon | 2N4122 |
| Q1070 | 151-0220-00 | | | Silicon | 2N4122 |
| Q1073 | 151-0220-00 | | | Silicon | 2N4122 |
| Q1084 | *151-0124-00 | B010100 | B189999 | Silicon | Selected from 2N3119 |
| Q1084 | *151-0274-00 | B190000 | | Silicon | Tek Spec |
| Q1094 | *151-0124-00 | B010100 | B189999 | Silicon | Selected from 2N3119 |
| Q1094 | *151-0274-00 | B190000 | | Silicon | Tek Spec |
| Q1116 | 151-0224-00 | | | Silicon | 2N3692 |
| Q1119 | 151-0224-00 | | | Silicon | 2N3692 |
| Q1124 | 151-0224-00 | | | Silicon | 2N3692 |
| Q1133 | *151-0136-00 | | | Silicon | Replaceable by 2N3053 |
| Q1137 | *151-0140-00 | | | Silicon | Selected from 2N3055 |
| Q1149 | 151-0224-00 | | | Silicon | 2N3692 |
| Q1154 | 151-0224-00 | | | Silicon | 2N3692 |
| Q1163 | *151-0136-00 | | | Silicon | Replaceable by 2N3053 |
| Q1167 | *151-0140-00 | | | Silicon | Selected from 2N3055 |
| Q1184 | 151-0224-00 | | | Silicon | 2N3692 |
| Q1193 | 151-0223-00 | | | Silicon | 2N4275 |
| Q1194 | 151-0224-00 | | | Silicon | 2N3692 |
| Q1197 | *151-0209-00 | | | Silicon | Selected from 2N3442 |

Transistors (cont)

| Ckt. No. | Tektronix Part No. | Serial/Model No. Eff | Disc | | Description |
|----------|--------------------|----------------------|---------|---------|-----------------------|
| Q1275 | 151-0224-00 | | | Silicon | 2N3692 |
| Q1285 | 151-0224-00 | | | Silicon | 2N3692 |
| Q1294 | 151-0220-00 | | | Silicon | 2N4122 |
| Q1314 | 151-0223-00 | | | Silicon | 2N4275 |
| Q1323 | 151-0223-00 | B010100 | B209999 | Silicon | 2N4275 |
| Q1323 | *151-0190-01 | B210000 | | Silicon | Tek Spec |
| Q1324 | 151-0214-00 | | | Silicon | 2N3495 |
| Q1334 | *151-0124-00 | | | Silicon | Selected from 2N3119 |
| Q1343 | *151-0096-00 | B010100 | B179999 | Silicon | Selected from 2N1893 |
| Q1343 | *151-0124-00 | B180000 | | Silicon | Selected from 2N3119 |
| Q1413 | 151-0220-00 | | | Silicon | 2N4122 |
| Q1414 | *151-0126-00 | | | Silicon | Replaceable by 2N2484 |
| Q1423 | *151-0136-00 | | | Silicon | Replaceable by 2N3053 |
| Q1430 | *151-0140-00 | | | Silicon | Selected from 2N3055 |

Resistors

Resistors are fixed, composition, $\pm 10\%$ unless otherwise indicated.

| | | | | | | | |
|-----|-------------|--|--|---------------------|-----------------|------|------|
| R2 | 317-0047-00 | | | 4.7 Ω | $\frac{1}{8}$ W | | 5% |
| R3 | 315-0105-00 | | | 1 M Ω | $\frac{1}{4}$ W | | 5% |
| R4 | 317-0470-00 | | | 47 Ω | $\frac{1}{8}$ W | | 5% |
| R5B | 322-0621-07 | | | 900 k Ω | $\frac{1}{4}$ W | Prec | 0.1% |
| R5C | 321-1389-07 | | | 111 k Ω | $\frac{1}{8}$ W | Prec | 0.1% |
| R5D | 317-0220-00 | | | 22 Ω | $\frac{1}{8}$ W | | 5% |
| R5E | 317-0560-00 | | | 56 Ω | $\frac{1}{8}$ W | | 5% |
| R6C | 322-0624-07 | | | 990 k Ω | $\frac{1}{4}$ W | Prec | 0.1% |
| R6D | 321-1289-07 | | | 10.1 k Ω | $\frac{1}{8}$ W | Prec | 0.1% |
| R6F | 317-0390-00 | | | 39 Ω | $\frac{1}{8}$ W | | 5% |
| R7 | 315-0270-00 | | | 27 Ω | $\frac{1}{4}$ W | | 5% |
| R8 | 315-0561-00 | | | 560 Ω | $\frac{1}{4}$ W | | 5% |
| R9 | 323-0481-01 | | | 1 M Ω | $\frac{1}{2}$ W | Prec | 0.5% |
| R10 | 315-0105-00 | | | 1 M Ω | $\frac{1}{4}$ W | | 5% |
| R13 | 301-0621-00 | | | 620 Ω | $\frac{1}{2}$ W | | 5% |
| R14 | 308-0403-00 | | | 8.5 k Ω | 3 W | WW | 1% |
| R15 | 315-0151-00 | | | 150 Ω | $\frac{1}{4}$ W | | 5% |
| R18 | 321-0093-00 | | | 90.9 Ω | $\frac{1}{8}$ W | Prec | 1% |
| R20 | 321-0184-00 | | | 806 Ω | $\frac{1}{8}$ W | Prec | 1% |
| R21 | 311-0258-00 | | | 100 Ω , Var | | | |
| R22 | 321-0121-00 | | | 178 Ω | $\frac{1}{8}$ W | Prec | 1% |
| R24 | 321-0130-00 | | | 221 Ω | $\frac{1}{8}$ W | Prec | 1% |
| R26 | 321-0193-00 | | | 1 k Ω | $\frac{1}{8}$ W | Prec | 1% |
| R28 | 311-0607-00 | | | 10 k Ω , Var | | | |
| R29 | 315-0223-00 | | | 22 k Ω | $\frac{1}{4}$ W | | 5% |
| R30 | 315-0100-00 | | | 10 Ω | $\frac{1}{4}$ W | | 5% |
| R31 | 321-0134-00 | | | 243 Ω | $\frac{1}{8}$ W | Prec | 1% |
| R32 | 315-0102-00 | | | 1 k Ω | $\frac{1}{4}$ W | | 5% |
| R34 | 321-0226-00 | | | 2.21 k Ω | $\frac{1}{8}$ W | Prec | 1% |
| R35 | 311-0091-00 | | | 1 k Ω , Var | | | |

Electrical Parts List—Type 454/R454

Resistors (cont)

| Kct. No. | Tektronix Part No. | Serial/Model No. Eff | No. Disc | Description | | |
|----------|--------------------|----------------------|----------|-------------|-------|-----------|
| R36 | 321-0216-00 | | | 1.74 kΩ | 1/8 W | Prec 1% |
| R37 | 317-0101-00 | | | 100 Ω | 1/8 W | 5% |
| R38 | 321-0179-00 | | | 715 Ω | 1/8 W | Prec 1% |
| R40 | 311-0634-00 | | | 500 Ω, Var | | |
| R41 | 321-0195-00 | | | 1.05 kΩ | 1/8 W | Prec 1% |
| R42 | 315-0272-00 | | | 2.7 kΩ | 1/4 W | 5% |
| R43 | 315-0151-00 | | | 150 Ω | 1/4 W | 5% |
| R44 | 311-0622-00 | | | 100 Ω, Var | | |
| R47 | 321-0143-07 | | | 301 Ω | 1/8 W | Prec 0.1% |
| R48 | 321-0197-00 | | | 1.1 kΩ | 1/8 W | Prec 1% |
| R49A | 311-0605-00 | | | 200 Ω, Var | | 1% |
| R49B | 321-0050-01 | | | 32.4 Ω | 1/8 W | Prec 0.5% |
| R49F | 321-0084-01 | | | 73.2 Ω | 1/8 W | Prec 0.5% |
| R49G | 311-0622-00 | | | 100 Ω, Var | | |
| R49H | 311-0635-00 | | | 1 kΩ, Var | | |
| R49J | 321-0125-01 | | | 196 Ω | 1/8 W | Prec 0.5% |
| R49N | 311-0635-00 | | | 1 kΩ, Var | | |
| R51 | 315-0221-00 | | | 220 Ω | 1/4 W | 5% |
| R52 | 311-0465-00 | | | 100 kΩ, Var | | |
| R53 | 315-0153-00 | | | 15 kΩ | 1/4 W | 5% |
| R54 | 301-0122-00 | | | 1.2 kΩ | 1/2 W | 5% |
| R56 | 315-0471-00 | | | 470 Ω | 1/4 W | 5% |
| R58 | 321-0051-00 | B010100 | B010119 | 33.2 Ω | 1/8 W | Prec 1% |
| R58 | 321-0042-00 | B010120 | | 26.7 Ω | 1/8 W | Prec 1% |
| R60A | 311-0638-00 | | | 80 Ω, Var | | |
| R60B | | | | | | |
| R62 | 321-0083-00 | | | 71.5 Ω | 1/8 W | Prec 1% |
| R63 | 315-0154-00 | | | 150 kΩ | 1/4 W | 5% |
| R64 | 321-0114-00 | | | 150 Ω | 1/8 W | Prec 1% |
| R65 | 317-0242-00 | | | 2.4 kΩ | 1/8 W | 5% |
| R66 | 321-0064-00 | | | 45.3 Ω | 1/8 W | Prec 1% |
| R67 | 311-0169-00 | | | 100 Ω, Var | | |
| R68 | 317-0100-00 | XB140000 | | 10 Ω | 1/8 W | 5% |
| R69 | 321-0198-00 | | | 1.13 kΩ | 1/8 W | Prec 1% |
| R76 | 321-0064-00 | | | 45.3 Ω | 1/8 W | Prec 1% |
| R78 | 321-0097-00 | | | 100 Ω | 1/8 W | Prec 1% |
| R79 | 321-0198-00 | | | 1.13 kΩ | 1/8 W | Prec 1% |
| R81 | 317-0201-00 | | | 200 Ω | 1/8 W | 5% |
| R82 | 317-0430-00 | | | 43 Ω | 1/8 W | 5% |
| R83 | 322-0156-00 | | | 412 Ω | 1/4 W | Prec 1% |
| R85 | 307-0106-00 | | | 4.7 Ω | 1/4 W | 5% |
| R86 | 321-0186-00 | | | 845 Ω | 1/8 W | Prec 1% |
| R91 | 317-0201-00 | | | 200 Ω | 1/8 W | 5% |
| R92 | 317-0430-00 | | | 43 Ω | 1/8 W | 5% |
| R93 | 322-0156-00 | | | 412 Ω | 1/4 W | Prec 1% |
| R96 | 321-0154-00 | | | 392 Ω | 1/8 W | Prec 1% |
| R102 | 317-0047-00 | | | 4.7 Ω | 1/8 W | 5% |
| R103 | 315-0105-00 | | | 1 MΩ | 1/4 W | 5% |

¹⁸Furnished as a unit with SW60.

Resistors (cont)

| Ckt. No. | Tektronix Part No. | Serial/Model No. Eff | No. Disc | Description | | |
|----------|--------------------|----------------------|---------------------|-----------------|------|------|
| R104 | 317-0470-00 | | 47 Ω | $\frac{1}{8}$ W | | 5% |
| R105B | 322-0621-07 | | 900 k Ω | $\frac{1}{4}$ W | Prec | 0.1% |
| R105C | 321-1389-07 | | 111 k Ω | $\frac{1}{8}$ W | Prec | 0.1% |
| R105D | 317-0220-00 | | 22 Ω | $\frac{1}{8}$ W | | 5% |
| R105E | 317-0560-00 | | 56 Ω | $\frac{1}{8}$ W | | 5% |
| R106C | 322-0624-07 | | 990 k Ω | $\frac{1}{4}$ W | Prec | 0.1% |
| R106D | 321-1289-07 | | 10.1 k Ω | $\frac{1}{8}$ W | Prec | 0.1% |
| R106F | 317-0390-00 | | 39 Ω | $\frac{1}{8}$ W | | 5% |
| R107 | 315-0270-00 | | 27 Ω | $\frac{1}{4}$ W | | 5% |
| R108 | 315-0561-00 | | 560 Ω | $\frac{1}{4}$ W | | 5% |
| R109 | 323-0481-01 | | 1 M Ω | $\frac{1}{2}$ W | Prec | 0.5% |
| R110 | 315-0105-00 | | 1 M Ω | $\frac{1}{4}$ W | | 5% |
| R113 | 301-0621-00 | | 620 Ω | $\frac{1}{2}$ W | | 5% |
| R114 | 308-0403-00 | | 8.5 k Ω | 3 W | WW | 1% |
| R115 | 315-0151-00 | | 150 Ω | $\frac{1}{4}$ W | | 5% |
| R118 | 321-0093-00 | | 90.9 Ω | $\frac{1}{8}$ W | Prec | 1% |
| R120 | 321-0184-00 | | 806 Ω | $\frac{1}{8}$ W | Prec | 1% |
| R121 | 311-0258-00 | | 100 Ω , Var | | | |
| R122 | 321-0121-00 | | 178 Ω | $\frac{1}{8}$ W | Prec | 1% |
| R124 | 321-0130-00 | | 221 Ω | $\frac{1}{8}$ W | Prec | 1% |
| R126 | 321-0193-00 | | 1 k Ω | $\frac{1}{8}$ W | Prec | 1% |
| R128 | 311-0607-00 | | 10 k Ω , Var | | | |
| R129 | 315-0223-00 | | 22 k Ω | $\frac{1}{4}$ W | | 5% |
| R130 | 315-0100-00 | | 10 Ω | $\frac{1}{4}$ W | | 5% |
| R131 | 321-0134-00 | | 243 Ω | $\frac{1}{8}$ W | Prec | 1% |
| R132 | 315-0102-00 | | 1 k Ω | $\frac{1}{4}$ W | | 5% |
| R134 | 321-0226-00 | | 2.21 k Ω | $\frac{1}{8}$ W | Prec | 1% |
| R135 | 311-0091-00 | | 1 k Ω , Var | | | |
| R136 | 321-0216-00 | | 1.74 k Ω | $\frac{1}{8}$ W | Prec | 1% |
| R137 | 317-0101-00 | | 100 Ω | $\frac{1}{8}$ W | | 5% |
| R138 | 321-0179-00 | | 715 Ω | $\frac{1}{8}$ W | Prec | 1% |
| R140 | 311-0634-00 | | 500 Ω , Var | | | |
| R141 | 321-0195-00 | | 1.05 k Ω | $\frac{1}{8}$ W | Prec | 1% |
| R142 | 315-0272-00 | | 2.7 k Ω | $\frac{1}{4}$ W | | 5% |
| R143 | 315-0151-00 | | 150 Ω | $\frac{1}{4}$ W | | 5% |
| R144 | 311-0622-00 | | 100 Ω , Var | | | |
| R147 | 321-0143-07 | | 301 Ω | $\frac{1}{8}$ W | Prec | 0.1% |
| R148 | 321-0197-00 | | 1.1 k Ω | $\frac{1}{8}$ W | Prec | 1% |
| R149A | 311-0605-00 | | 200 Ω , Var | | | |
| R149B | 321-0050-01 | | 32.4 Ω | $\frac{1}{8}$ W | Prec | 0.5% |
| R149F | 321-0084-01 | | 73.2 Ω | $\frac{1}{8}$ W | Prec | 0.5% |
| R149G | 311-0622-00 | | 100 Ω , Var | | | |
| R149H | 311-0635-00 | | 1 k Ω , Var | | | |
| R149J | 321-0125-01 | | 196 Ω | $\frac{1}{8}$ W | Prec | 0.5% |
| R149N | 311-0635-00 | | 1 k Ω , Var | | | |
| R150 | 315-0470-00 | | 47 Ω | $\frac{1}{4}$ W | | 5% |
| R160A | 311-0638-00 | } ¹⁶ | 80 Ω , Var | | | |
| R160B | | | 1 k Ω , Var | | | |

¹⁶Furnished as a unit with SW160.

Electrical Parts List—Type 454/R454

Resistors (cont)

| Ckt. No. | Tektronix Part No. | Serial/Model No. Eff | Disc | Description | | |
|----------|--------------------|----------------------|---------|--------------------|-----------------|---------|
| R162 | 321-0083-00 | | | 71.5 Ω | $\frac{1}{8}$ W | Prec 1% |
| R163 | 315-0154-00 | | | 150 k Ω | $\frac{1}{4}$ W | 5% |
| R164 | 321-0114-00 | | | 150 Ω | $\frac{1}{8}$ W | Prec 1% |
| R165 | 317-0242-00 | | | 2.4 k Ω | $\frac{1}{8}$ W | 5% |
| R166 | 321-0064-00 | | | 45.3 Ω | $\frac{1}{8}$ W | Prec 1% |
| R167 | 311-0169-00 | | | 100 Ω , Var | | |
| R168 | 317-0100-00 | XB140000 | | 10 Ω | $\frac{1}{8}$ W | 5% |
| R169 | 321-0198-00 | | | 1.13 k Ω | $\frac{1}{8}$ W | Prec 1% |
| R176 | 321-0064-00 | | | 45.3 Ω | $\frac{1}{8}$ W | Prec 1% |
| R178 | 321-0097-00 | | | 100 Ω | $\frac{1}{8}$ W | Prec 1% |
| R179 | 321-0198-00 | | | 1.13 k Ω | $\frac{1}{8}$ W | Prec 1% |
| R181 | 317-0201-00 | | | 200 Ω | $\frac{1}{8}$ W | 5% |
| R182 | 317-0430-00 | | | 43 Ω | $\frac{1}{8}$ W | 5% |
| R183 | 322-0156-00 | | | 412 Ω | $\frac{1}{4}$ W | Prec 1% |
| R185 | 307-0106-00 | | | 4.7 Ω | $\frac{1}{4}$ W | 5% |
| R186 | 321-0186-00 | | | 845 Ω | $\frac{1}{8}$ W | Prec 1% |
| R191 | 317-0201-00 | | | 200 Ω | $\frac{1}{8}$ W | 5% |
| R192 | 317-0430-00 | | | 43 Ω | $\frac{1}{8}$ W | 5% |
| R193 | 322-0156-00 | | | 412 Ω | $\frac{1}{4}$ W | Prec 1% |
| R196 | 321-0154-00 | | | 392 Ω | $\frac{1}{8}$ W | Prec 1% |
| R207 | 321-0158-00 | | | 432 Ω | $\frac{1}{8}$ W | Prec 1% |
| R208 | 321-0158-00 | | | 432 Ω | $\frac{1}{8}$ W | Prec 1% |
| R210 | 321-0175-00 | | | 649 Ω | $\frac{1}{8}$ W | Prec 1% |
| R212 | 321-0138-00 | | | 267 Ω | $\frac{1}{8}$ W | Prec 1% |
| R213 | 315-0200-00 | | | 20 Ω | $\frac{1}{4}$ W | 5% |
| R214 | 321-0103-00 | | | 115 Ω | $\frac{1}{8}$ W | Prec 1% |
| R215 | 321-0193-00 | | | 1 k Ω | $\frac{1}{8}$ W | Prec 1% |
| R216 | 321-0229-00 | | | 2.37 k Ω | $\frac{1}{8}$ W | Prec 1% |
| R217 | 315-0242-00 | B010100 | B209999 | 2.4 k Ω | $\frac{1}{4}$ W | 5% |
| R217 | 315-0362-00 | B210000 | | 3.6 k Ω | $\frac{1}{4}$ W | 5% |
| R219 | 321-0125-00 | | | 196 Ω | $\frac{1}{8}$ W | Prec 1% |
| R220 | 321-0175-00 | | | 649 Ω | $\frac{1}{8}$ W | Prec 1% |
| R222 | 321-0138-00 | | | 267 Ω | $\frac{1}{8}$ W | Prec 1% |
| R223 | 315-0200-00 | | | 20 Ω | $\frac{1}{4}$ W | 5% |
| R224 | 321-0103-00 | | | 115 Ω | $\frac{1}{8}$ W | Prec 1% |
| R225 | 321-0193-00 | | | 1 k Ω | $\frac{1}{8}$ W | Prec 1% |
| R226 | 321-0229-00 | | | 2.37 k Ω | $\frac{1}{8}$ W | Prec 1% |
| R229 | 321-0125-00 | | | 196 Ω | $\frac{1}{8}$ W | Prec 1% |
| R233 | 321-0081-00 | | | 68.1 Ω | $\frac{1}{8}$ W | Prec 1% |
| R234 | 315-0102-00 | | | 1 k Ω | $\frac{1}{4}$ W | 5% |
| R236 | 315-0153-00 | | | 15 k Ω | $\frac{1}{4}$ W | 5% |
| R241 | 315-0753-00 | | | 75 k Ω | $\frac{1}{4}$ W | 5% |
| R244 | 315-0472-00 | | | 4.7 k Ω | $\frac{1}{4}$ W | 5% |
| R245 | 315-0332-00 | | | 3.3 k Ω | $\frac{1}{4}$ W | 5% |
| R253 | 315-0102-00 | | | 1 k Ω | $\frac{1}{4}$ W | 5% |
| R255 | 315-0221-00 | | | 220 Ω | $\frac{1}{4}$ W | 5% |
| R270 | 321-0178-00 | | | 698 Ω | $\frac{1}{8}$ W | Prec 1% |

Resistors (cont)

| Ckt. No. | Tektronix Part No. | Serial/Model No. Eff | No. Disc | Description | | | |
|------------------------------|--------------------|----------------------|----------|---------------|-------|--------------------------|-----|
| R272 | 311-0480-00 | | | 500 Ω, Var | | | |
| R273 | 315-0102-00 | | | 1 kΩ | 1/4 W | | 5% |
| R274 | 321-0158-00 | | | 432 Ω | 1/8 W | Prec | 1% |
| R276 | 321-0137-00 | | | 261 Ω | 1/8 W | Prec | 1% |
| R278 | 321-0087-00 | | | 78.7 Ω | 1/8 W | Prec | 1% |
| R279 | 323-0099-00 | | | 105 Ω | 1/2 W | Prec | 1% |
| R280 | 321-0178-00 | | | 698 Ω | 1/8 W | Prec | 1% |
| R283 | 321-0169-00 | | | 562 Ω | 1/8 W | Prec | 1% |
| R284 | 321-0277-00 | | | 7.5 kΩ | 1/8 W | Prec | 1% |
| R286 | 321-0137-00 | | | 261 Ω | 1/8 W | Prec | 1% |
| R288 | 321-0087-00 | | | 78.7 Ω | 1/8 W | Prec | 1% |
| R307 | 321-0091-00 | | | 86.6 Ω | 1/8 W | Prec | 1% |
| R308 | 317-0680-00 | | | 68 Ω | 1/8 W | | 5% |
| R311 | 315-0222-00 | | | 2.2 kΩ | 1/4 W | | 5% |
| R312 | 315-0181-00 | | | 180 Ω | 1/4 W | | 5% |
| R316 | 315-0201-00 | | | 200 Ω | 1/4 W | | 5% |
| R318 | 321-0116-00 | B010100 | B010119 | 158 Ω | 1/8 W | Prec | 1% |
| R318 | 321-0121-00 | B010120 | | 178 Ω | | Selected (nominal value) | |
| R321 | 321-0105-00 | | | 121 Ω | 1/8 W | Prec | 1% |
| R323 | 321-0105-00 | | | 121 Ω | 1/8 W | Prec | 1% |
| R324 | 321-0075-00 | | | 59 Ω | 1/8 W | Prec | 1% |
| R325 | 315-0123-00 | | | 12 kΩ | 1/4 W | | 5% |
| R327 | 317-0273-00 | | | 27 kΩ | 1/8 W | | 5% |
| R330 | 317-0390-00 | | | 39 Ω | 1/8 W | | 5% |
| R331 | 317-0431-00 | | | 430 Ω | 1/8 W | | 5% |
| R332 | 317-0242-00 | | | 2.4 kΩ | 1/8 W | | 5% |
| R334 | 311-0644-00 | | | 20 kΩ, Var | | | |
| R335 | 317-0680-00 | | | 68 Ω | 1/8 W | | 5% |
| R336 | 321-0189-00 | XB010120 | | 909 Ω | 1/8 W | Prec | 1% |
| (Added in test if necessary) | | | | | | | |
| R338 | 321-0094-00 | | | 93.1 Ω | 1/8 W | Prec | 1% |
| R339 | 315-0221-00 | | | 220 Ω | 1/4 W | | 5% |
| R340 | 315-0751-00 | | | 750 Ω | 1/4 W | | 5% |
| R341 | 322-0114-00 | | | 150 Ω | 1/4 W | Prec | 1% |
| R346 | 321-0055-00 | | | 36.5 Ω | 1/8 W | Prec | 1% |
| R347 | 321-0055-00 | | | 36.5 Ω | 1/8 W | Prec | 1% |
| R353 | 311-0605-00 | | | 200 Ω, Var | | | |
| R355 | 317-0470-00 | | | 47 Ω | 1/8 W | | 5% |
| R356 | 317-0221-00 | | | 220 Ω | 1/8 W | | 5% |
| R357 | 317-0221-00 | | | 220 Ω | 1/8 W | | 5% |
| R362 | 315-0181-00 | | | 180 Ω | 1/4 W | | 5% |
| R364 | 317-0391-00 | | | 390 Ω | 1/8 W | | 5% |
| R365 | 311-0633-00 | | | 5 kΩ, Var | | | |
| R368 | 321-0076-00 | | | 60.4 Ω | 1/8 W | Prec | 1% |
| R370 | 321-0036-00 | | | 23.2 Ω | 1/8 W | Prec | 1% |
| R371 | 321-0036-00 | | | 23.2 Ω | 1/8 W | Prec | 1% |
| R372 | 308-0450-00 | | | 70 Ω | 3 W | WW | 1% |
| R373 | 307-0125-00 | | | 500 Ω at 25°C | | | 10% |

Electrical Parts List—Type 454/R454

Resistors (cont)

| Ckt. No. | Tektronix Part No. | Serial/Model No. Eff | Disc | Description | | |
|------------------------------|--------------------|----------------------|--------------|-------------|------|----|
| R375 | 301-0150-00 | | 15 Ω | 1/2 W | | 5% |
| R381 | 301-0103-00 | | 10 kΩ | 1/2 W | | 5% |
| R382 | 311-0634-00 | | 500 Ω, Var | | | |
| R383 | 315-0271-00 | | 270 Ω | 1/4 W | | 5% |
| R385 | 301-0912-00 | | 9.1 kΩ | 1/2 W | | 5% |
| R394 | 311-0609-00 | | 2 kΩ, Var | | | |
| R396 | 305-0750-00 | | 75 Ω | 2 W | | 5% |
| R397 | 308-0425-00 | | 350 Ω | 5 W | WW | 1% |
| R407 | 321-0091-00 | | 86.6 Ω | 1/8 W | Prec | 1% |
| R416 | 315-0201-00 | | 200 Ω | 1/4 W | | 5% |
| R417 | 311-0633-00 | | 5 kΩ, Var | | | |
| R418 | 321-0120-00 | | 174 Ω | 1/8 W | Prec | 1% |
| R419 | 311-0634-00 | | 500 Ω, Var | | | |
| R421 | 321-0105-00 | | 121 Ω | 1/8 W | Prec | 1% |
| R423 | 321-0105-00 | | 121 Ω | 1/8 W | Prec | 1% |
| R424 | 307-0124-00 | | 5 kΩ at 25°C | | | |
| R426 | 311-0635-00 | | 1 kΩ, Var | | | |
| R430 | 317-0390-00 | | 39 Ω | 1/8 W | | 5% |
| R431 | 317-0431-00 | | 430 Ω | 1/8 W | | 5% |
| R432 | 317-0242-00 | | 2.4 kΩ | 1/8 W | | 5% |
| R434 | 315-0221-00 | | 220 Ω | 1/4 W | | 5% |
| R435 | 317-0680-00 | | 68 Ω | 1/8 W | | 5% |
| R438 | 321-0094-00 | | 93.1 Ω | 1/8 W | Prec | 1% |
| R442 | 301-0221-00 | | 220 Ω | 1/2 W | | 5% |
| R446 | 321-0055-00 | | 36.5 Ω | 1/8 W | Prec | 1% |
| R447 | 321-0055-00 | | 36.5 Ω | 1/8 W | Prec | 1% |
| R455 | 317-0470-00 | | 47 Ω | 1/8 W | | 5% |
| R456 | 317-0221-00 | | 220 Ω | 1/8 W | | 5% |
| R457 | 317-0221-00 | | 220 Ω | 1/8 W | | 5% |
| R464 | 317-0201-00 | | 200 Ω | 1/8 W | | 5% |
| R468 | 321-0076-00 | | 60.4 Ω | 1/8 W | Prec | 1% |
| R470 | 321-0036-00 | | 23.2 Ω | 1/8 W | Prec | 1% |
| R471 | 321-0036-00 | | 23.2 Ω | 1/8 W | Prec | 1% |
| R475 | 301-0150-00 | | 15 Ω | 1/2 W | | 5% |
| R494 | 311-0609-00 | | 2 kΩ, Var | | | |
| R495 | 315-0472-00 | XB010120 | 4.7 kΩ | 1/4 W | | 5% |
| (Added in test if necessary) | | | | | | |
| R497 | 308-0425-00 | | 350 Ω | 5 W | WW | 1% |
| R501 | 321-0097-00 | | 100 Ω | 1/8 W | Prec | 1% |
| R503 | 321-0097-00 | | 100 Ω | 1/8 W | Prec | 1% |
| R505 | 316-0154-00 | | 150 kΩ | 1/4 W | | |
| R506 | 316-0154-00 | | 150 kΩ | 1/4 W | | |
| R509 | 321-0097-00 | | 100 Ω | 1/8 W | Prec | 1% |
| R510 | 321-0198-00 | | 1.13 kΩ | 1/8 W | Prec | 1% |
| R511 | 311-0480-00 | | 500 Ω, Var | | | |
| R513 | 315-0470-00 | | 47 Ω | 1/4 W | | 5% |
| R514 | 321-0213-00 | | 1.62 kΩ | 1/8 W | Prec | 1% |

Resistors (cont)

| Kct. No. | Tektronix Part No. | Serial/Model No. Eff | Disc | | Description | | |
|----------|--------------------|----------------------|---------|---------------------|-----------------|------|----|
| R515 | 321-0114-00 | | | 150 Ω | $\frac{1}{8}$ W | Prec | 1% |
| R516 | 321-0207-00 | | | 1.4 k Ω | $\frac{1}{8}$ W | Prec | 1% |
| R517 | 315-0470-00 | | | 47 Ω | $\frac{1}{4}$ W | | 5% |
| R518 | 321-0154-00 | | | 392 Ω | $\frac{1}{8}$ W | Prec | 1% |
| R519 | 316-0100-00 | B010100 | B219999 | 10 Ω | $\frac{1}{4}$ W | | |
| R519 | 315-0100-00 | B220000 | | 10 Ω | $\frac{1}{4}$ W | | 5% |
| R520 | 315-0101-00 | | | 100 Ω | $\frac{1}{4}$ W | | 5% |
| R525 | 321-0193-00 | | | 1 k Ω | $\frac{1}{8}$ W | Prec | 1% |
| R530 | 315-0470-00 | B010100 | B199999 | 47 Ω | $\frac{1}{4}$ W | | 5% |
| R530 | 315-0750-00 | B200000 | | 75 Ω | $\frac{1}{4}$ W | | 5% |
| R531 | 316-0470-00 | B010100 | B219999 | 47 Ω | $\frac{1}{4}$ W | | |
| R531 | 315-0470-00 | B220000 | | 47 Ω | $\frac{1}{4}$ W | | 5% |
| R532 | 321-0139-00 | | | 274 Ω | $\frac{1}{8}$ W | Prec | 1% |
| R534 | 321-0191-00 | | | 953 Ω | $\frac{1}{8}$ W | Prec | 1% |
| R536 | 321-0175-00 | | | 649 Ω | $\frac{1}{8}$ W | Prec | 1% |
| R538 | 315-0470-00 | | | 47 Ω | $\frac{1}{4}$ W | | 5% |
| R539 | 307-0106-00 | | | 4.7 Ω | $\frac{1}{4}$ W | | 5% |
| R544 | 315-0220-00 | | | 22 Ω | $\frac{1}{4}$ W | | 5% |
| R560 | 315-0100-00 | | | 10 Ω | $\frac{1}{4}$ W | | 5% |
| R561 | 323-0154-00 | | | 392 Ω | $\frac{1}{2}$ W | Prec | 1% |
| R563 | 321-0126-00 | | | 200 Ω | $\frac{1}{8}$ W | Prec | 1% |
| R565 | 321-0137-00 | | | 261 Ω | $\frac{1}{8}$ W | Prec | 1% |
| R566 | 321-0190-00 | | | 931 Ω | $\frac{1}{8}$ W | Prec | 1% |
| R567 | 311-0095-00 | | | 500 Ω , Var | | | |
| R569 | 311-0643-00 | | | 50 Ω , Var | | | |
| R601 | 316-0100-00 | | | 10 Ω | $\frac{1}{4}$ W | | |
| R602 | 315-0100-00 | XB200000 | | 10 Ω | $\frac{1}{4}$ W | | 5% |
| R604B | 301-0914-00 | | | 910 k Ω | $\frac{1}{2}$ W | | 5% |
| R604C | 315-0114-00 | | | 110 k Ω | $\frac{1}{4}$ W | | 5% |
| R607 | 315-0563-00 | | | 56 k Ω | $\frac{1}{4}$ W | | 5% |
| R609 | 315-0104-00 | | | 100 k Ω | $\frac{1}{4}$ W | | 5% |
| R615 | 301-0105-00 | | | 1 M Ω | $\frac{1}{2}$ W | | 5% |
| R617 | 315-0105-00 | | | 1 M Ω | $\frac{1}{4}$ W | | 5% |
| R619 | 315-0180-00 | B010100 | B219999 | 18 Ω | $\frac{1}{4}$ W | | 5% |
| R619 | 315-0470-00 | B220000 | | 47 Ω | $\frac{1}{4}$ W | | 5% |
| R623 | 316-0102-00 | B010100 | B219999 | 1 k Ω | $\frac{1}{4}$ W | | |
| R623 | 315-0102-00 | B220000 | | 1 k Ω | $\frac{1}{4}$ W | | 5% |
| R624 | 316-0151-00 | B010100 | B199999 | 150 Ω | $\frac{1}{4}$ W | | |
| R624 | 315-0101-00 | B200000 | | 100 Ω | $\frac{1}{4}$ W | | 5% |
| R628 | 315-0182-00 | | | 1.8 k Ω | $\frac{1}{4}$ W | | 5% |
| R637 | 315-0162-00 | B010100 | B219999 | 1.6 k Ω | $\frac{1}{4}$ W | | 5% |
| R637 | 315-0122-00 | B220000 | | 1.2 k Ω | $\frac{1}{4}$ W | | 5% |
| R640 | 315-0510-00 | XB220000 | | 51 Ω | $\frac{1}{4}$ W | | 5% |
| R641 | 315-0362-00 | | | 3.6 k Ω | $\frac{1}{4}$ W | | 5% |
| R642 | 315-0133-00 | | | 13 k Ω | $\frac{1}{4}$ W | | 5% |
| R643 | 311-0510-00 | | | 10 k Ω , Var | | | |

Electrical Parts List—Type 454/R454

Resistors (cont)

| Ckt. No. | Tektronix Part No. | Serial/Model No. Eff | Disc | | Description | |
|----------|--------------------|-------------------------|---------|------------|-------------|----|
| R644 | 315-0272-00 | | | 2.7 kΩ | 1/4 W | 5% |
| R645 | 315-0270-00 | | | 27 Ω | 1/4 W | 5% |
| R646 | 315-0391-00 | | | 390 Ω | 1/4 W | 5% |
| R648 | 315-0122-00 | | | 1.2 kΩ | 1/4 W | 5% |
| R649 | 311-0555-00 | | | 10 kΩ, Var | | |
| R656 | 315-0360-00 | B010100 | B059999 | 36 Ω | 1/4 W | 5% |
| R656 | 317-0560-00 | B060000 | B069999 | 56 Ω | 1/8 W | 5% |
| R656 | 315-0181-00 | B070000 | | 180 Ω | 1/4 W | 5% |
| R657 | 315-0472-00 | B010100 | B219999 | 4.7 kΩ | 1/4 W | 5% |
| R657 | 315-0223-00 | B220000 | | 22 kΩ | 1/4 W | 5% |
| R658 | 315-0431-00 | B010100 | B219999 | 430 Ω | 1/4 W | 5% |
| R658 | 315-0361-00 | B220000 | | 360 Ω | 1/4 W | 5% |
| R659 | 315-0100-00 | | | 10 Ω | 1/4 W | 5% |
| R664 | 301-0153-00 | B010100 | B029999 | 15 kΩ | 1/2 W | 5% |
| R664 | 301-0273-00 | B030000 | | 27 kΩ | 1/2 W | 5% |
| R665 | 315-0302-00 | XB220000 | | 3 kΩ | 1/4 W | 5% |
| R666 | 317-0560-00 | | | 56 Ω | 1/8 W | 5% |
| R667 | 315-0102-00 | XB220000 | | 1 kΩ | 1/4 W | 5% |
| R668 | 315-0152-00 | XB220000 | | 1.5 kΩ | 1/4 W | 5% |
| R670 | 315-0152-00 | XB220000 | | 1.5 kΩ | 1/4 W | 5% |
| R671 | 315-0103-00 | B010100 | B219999 | 10 kΩ | 1/4 W | 5% |
| R671 | 321-0257-00 | B220000 | | 4.64 kΩ | 1/8 W | 1% |
| R672 | 315-0101-00 | XB220000 | | 100 Ω | 1/4 W | 5% |
| R673 | 315-0330-00 | B010100 | B219999 | 33 Ω | 1/4 W | 5% |
| R673 | 315-0180-00 | B220000 | | 18 Ω | 1/4 W | 5% |
| R674 | 315-0392-00 | B010100 | B069999 | 3.9 kΩ | 1/4 W | 5% |
| R674 | 315-0153-00 | B070000 | B219999 | 15 kΩ | 1/4 W | 5% |
| R674 | 315-0152-00 | B220000 | | 1.5 kΩ | 1/4 W | 5% |
| R676 | 315-0510-00 | B070000 | B219999 | 51 Ω | 1/4 W | 5% |
| R676 | 315-0471-00 | B220000 | | 470 Ω | 1/4 W | 5% |
| R677 | 315-0101-00 | XB220000 | | 100 Ω | 1/4 W | 5% |
| R680 | 315-0101-00 | XB220000 | | 100 Ω | 1/4 W | 5% |
| R681 | 315-0273-00 | | | 27 kΩ | 1/4 W | 5% |
| R684 | 315-0511-00 | XB220000 | | 510 Ω | 1/4 W | 5% |
| R685 | 315-0104-00 | | | 100 kΩ | 1/4 W | 5% |
| R690 | 315-0104-00 | | | 100 kΩ | 1/4 W | 5% |
| R692 | 315-0470-00 | | | 47 Ω | 1/4 W | 5% |
| R694 | 315-0272-00 | | | 2.7 kΩ | 1/4 W | 5% |
| R696 | 315-0271-00 | B010100 | B069999 | 270 Ω | 1/4 W | 5% |
| R696 | 315-0910-00 | B070000 | | 91 Ω | 1/4 W | 5% |
| R697 | 315-0103-00 | B010100 | B069999 | 10 kΩ | 1/4 W | 5% |
| R697 | 315-0332-00 | B070000 | | 3.3 kΩ | 1/4 W | 5% |
| R699 | 315-0152-00 | B010100 | B069999 | 1.5 kΩ | 1/4 W | 5% |
| R699 | 315-0102-00 | B070000 | | 1 kΩ | 1/4 W | 5% |
| R701 | 315-0101-00 | | | 100 Ω | 1/4 W | 5% |

Electrical Parts List—Type 454/R454

Resistors (cont)

| Ckt. No. | Tektronix Part No. | Serial/Model No. Eff | Disc | Description | | |
|----------|--------------------|----------------------|---------|-------------|-------|------|
| R702 | 315-0330-00 | | | 33 Ω | 1/4 W | 5% |
| R703 | 315-0470-00 | XB220000 | | 47 Ω | 1/4 W | 5% |
| R704 | 321-0159-00 | | | 442 Ω | 1/8 W | 1% |
| R705 | 316-0103-00 | B010100 | B219999 | 10 kΩ | 1/4 W | Prec |
| R705 | 315-0103-00 | B220000 | | 10 kΩ | 1/4 W | 5% |
| R710 | 315-0202-00 | | | 2 kΩ | 1/4 W | 5% |
| R712 | 321-0164-00 | | | 499 Ω | 1/8 W | 1% |
| R713 | 321-0261-00 | | | 6.19 kΩ | 1/8 W | Prec |
| R714 | 316-0102-00 | B010100 | B219999 | 1 kΩ | 1/4 W | Prec |
| R714 | 315-0102-00 | B220000 | | 1 kΩ | 1/4 W | 5% |
| R715 | 315-0101-00 | | | 100 Ω | 1/4 W | 5% |
| R716 | 323-0149-00 | | | 348 Ω | 1/2 W | Prec |
| R717 | 321-0261-00 | | | 5.11 kΩ | 1/8 W | Prec |
| R718 | 315-0562-00 | | | 5.6 kΩ | 1/4 W | 5% |
| R719 | 315-0823-00 | | | 82 kΩ | 1/4 W | 5% |
| R720 | 321-0164-00 | | | 499 Ω | 1/8 W | Prec |
| R721 | 321-0213-00 | | | 1.62 kΩ | 1/8 W | Prec |
| R722 | 316-0101-00 | B010100 | B219999 | 100 Ω | 1/4 W | |
| R722 | 315-0101-00 | B220000 | | 100 Ω | 1/4 W | 5% |
| R723 | 316-0470-00 | B010100 | B219999 | 47 Ω | 1/4 W | |
| R723 | 315-0470-00 | B220000 | | 47 Ω | 1/4 W | 5% |
| R724 | 301-0681-00 | | | 680 Ω | 1/2 W | 5% |
| R725 | 316-0100-00 | B010100 | B219999 | 10 Ω | 1/4 W | |
| R725 | 315-0100-00 | B220000 | | 10 Ω | 1/4 W | 5% |
| R726 | 315-0620-00 | | | 62 Ω | 1/4 W | 5% |
| R727 | 316-0331-00 | B010100 | B219999 | 330 Ω | 1/4 W | |
| R727 | 315-0331-00 | B220000 | | 330 Ω | 1/4 W | 5% |
| R728 | 316-0333-00 | B010100 | B219999 | 33 kΩ | 1/4 W | |
| R728 | 315-0333-00 | B220000 | | 33 kΩ | 1/4 W | 5% |
| R729 | 316-0332-00 | B010100 | B219999 | 3.3 kΩ | 1/4 W | |
| R729 | 315-0332-00 | B220000 | | 3.3 kΩ | 1/4 W | 5% |
| R730 | 316-0101-00 | B010100 | B219999 | 100 Ω | 1/4 W | |
| R730 | 315-0101-00 | B220000 | | 100 Ω | 1/4 W | 5% |
| R731 | 316-0101-00 | B010100 | B219999 | 100 Ω | 1/4 W | |
| R731 | 315-0101-00 | B220000 | | 100 Ω | 1/4 W | 5% |
| R733 | 315-0622-00 | | | 6.2 kΩ | 1/4 W | 5% |
| R735 | 316-0101-00 | B010100 | B219999 | 100 Ω | 1/4 W | |
| R735 | 315-0101-00 | B220000 | | 100 Ω | 1/4 W | 5% |
| R737 | 321-0256-00 | | | 4.53 kΩ | 1/8 W | Prec |
| R738 | 321-0297-00 | | | 12.1 kΩ | 1/8 W | Prec |
| R739 | 316-0272-00 | B010100 | B219999 | 2.7 kΩ | 1/4 W | |
| R739 | 315-0272-00 | B220000 | | 2.7 kΩ | 1/4 W | 5% |
| R740A | 323-0739-02 | | | 157.4 kΩ | 1/2 W | Prec |
| R740C | 323-0739-02 | | | 157.4 kΩ | 1/2 W | Prec |
| R740E | 323-0375-01 | | | 78.7 kΩ | 1/2 W | Prec |

Electrical Parts List—Type 454/R454

Resistors (cont)

| Ckt. No. | Tektronix Part No. | Serial/Model No. Eff | No. Disc | Description | | |
|---------------------|--------------------|----------------------|----------|-------------|-------|-----------|
| R740F | 301-0225-00 | | | 2.2 MΩ | 1/2 W | 5% |
| R740G | 323-0584-00 | | | 11.8 MΩ | 1/2 W | Prec 1% |
| R740H | 323-0584-00 | | | 11.8 MΩ | 1/2 W | Prec 1% |
| R740J | 323-0567-00 | | | 7.87 MΩ | 1/2 W | Prec 1% |
| R740K | 323-0737-00 | | | 3.935 MΩ | 1/2 W | Prec 1% |
| R740M | 323-0738-01 | | | 2.361 MΩ | 1/2 W | Prec 0.5% |
| R740P | 323-0471-01 | | | 787 kΩ | 1/2 W | Prec 0.5% |
| R740R | 323-0471-07 | | | 787 kΩ | 1/2 W | Prec 0.1% |
| R740S ¹⁷ | 311-0554-00 | | | 20 kΩ, Var | | |
| R740T | 315-0272-00 | | | 2.7 kΩ | 1/4 W | 5% |
| R740W | 316-0154-00 | | | 150 kΩ | 1/4 W | |
| R741 | 301-0221-00 | | | 220 Ω | 1/2 W | 5% |
| R742 | 316-0106-00 | XB090000 | | 10 MΩ | 1/4 W | |
| R743 | 311-0462-00 | | | 1 kΩ, Var | | |
| R745 | 308-0307-00 | | | 5 kΩ | 3 W | WW 1% |
| R749 | 315-0220-00 | | | 22 Ω | 1/4 W | 5% |
| R750 | 301-0331-00 | | | 330 Ω | 1/2 W | 5% |
| R752 | 315-0222-00 | | | 2.2 kΩ | 1/4 W | 5% |
| R753 | 321-0259-00 | | | 4.87 kΩ | 1/8 W | Prec 1% |
| R754 | 322-0338-00 | | | 32.4 kΩ | 1/4 W | Prec 1% |
| R755 | 321-0258-00 | | | 4.75 kΩ | 1/8 W | Prec 1% |
| R756 | 315-0101-00 | | | 100 Ω | 1/4 W | 5% |
| R757 | 303-0912-00 | | | 9.1 kΩ | 1 W | 5% |
| R758 | 315-0101-00 | | | 100 Ω | 1/4 W | 5% |
| R759 | 321-0239-00 | | | 3.01 kΩ | 1/8 W | Prec 1% |
| R761 | 315-0102-00 | | | 1 kΩ | 1/4 W | 5% |
| R762 ¹⁸ | 311-0553-00 | | | 10 kΩ, Var | | |
| R763 | 321-0372-00 | | | 73.2 kΩ | 1/8 W | Prec 1% |
| R765 | 311-0547-00 | B010100 | B259999 | 10 kΩ, Var | | |
| R765 | 311-0191-00 | B260000 | | 10 kΩ, Var | | |
| R766 | 323-0347-00 | | | 40.2 kΩ | 1/2 W | Prec 1% |
| R768 | 315-0910-00 | | | 91 Ω | 1/4 W | 5% |
| R769 | 315-0202-00 | | | 2 kΩ | 1/4 W | 5% |
| R770 | 322-0188-00 | | | 887 Ω | 1/4 W | Prec 1% |
| R771 | 322-0202-00 | | | 1.24 kΩ | 1/4 W | Prec 1% |
| R772 | 321-0141-00 | | | 287 Ω | 1/8 W | Prec 1% |
| R773 | 321-0327-00 | | | 24.9 kΩ | 1/8 W | Prec 1% |
| R774 | 316-0101-00 | B010100 | B219999 | 100 Ω | 1/4 W | |
| R774 | 315-0101-00 | B220000 | | 100 Ω | 1/4 W | 5% |
| R775 | 321-0268-00 | | | 6.04 kΩ | 1/8 W | Prec 1% |
| R776 | 315-0270-00 | XB150000 | | 27 Ω | 1/4 W | 5% |
| R777 | 321-0182-00 | | | 768 Ω | 1/8 W | Prec 1% |
| R778 | 316-0470-00 | B010100 | B219999 | 47 Ω | 1/4 W | |
| R778 | 315-0470-00 | B220000 | | 47 Ω | 1/4 W | 5% |
| R779 | 321-0241-00 | B010100 | B219999 | 3.16 kΩ | 1/8 W | Prec 1% |
| R779 | 321-0245-00 | B220000 | | 3.48 kΩ | 1/8 W | Prec 1% |
| R780 | 316-0682-00 | B010100 | B219999 | 6.8 kΩ | 1/4 W | |
| R780 | 315-0682-00 | B220000 | | 6.8 kΩ | 1/4 W | 5% |
| R781 | 315-0224-00 | | | 220 kΩ | 1/4 W | 5% |
| R782 | 315-0392-00 | | | 3.9 kΩ | 1/4 W | 5% |
| R784 | 316-0222-00 | B010100 | B219999 | 2.2 kΩ | 1/4 W | |
| R784 | 315-0222-00 | B220000 | | 2.2 kΩ | 1/4 W | 5% |

¹⁷Furnished as a unit with SW740S.

¹⁸Furnished as a unit with R849.

Resistors (cont)

| Ckt. No. | Tektronix Part No. | Serial/Model No. | | Description | | |
|--------------------|--------------------|------------------|---------|---------------------|-------|---------|
| | | Eff | Disc | | | |
| R785 | 316-0102-00 | B010100 | B219999 | 1 k Ω | 1/4 W | |
| R785 | 315-0102-00 | B220000 | | 1 k Ω | 1/4 W | 5% |
| R786 | 316-0223-00 | B010100 | B219999 | 22 k Ω | 1/4 W | |
| R786 | 315-0223-00 | B220000 | | 22 k Ω | 1/4 W | 5% |
| R787 | 316-0473-00 | B010100 | B219999 | 47 k Ω | 1/4 W | |
| R787 | 315-0473-00 | B220000 | | 47 k Ω | 1/4 W | 5% |
| R790 | 321-0268-00 | | | 6.04 k Ω | 1/8 W | Prec 1% |
| R791 | 321-0266-00 | | | 5.76 k Ω | 1/8 W | Prec 1% |
| R793 | 301-0820-00 | | | 82 Ω | 1/2 W | 5% |
| R794 | 315-0473-00 | | | 47 k Ω | 1/4 W | 5% |
| R796 | 315-0622-00 | | | 6.2 k Ω | 1/4 W | 5% |
| R797 | 321-0273-00 | B010100 | B219999 | 6.81 k Ω | 1/6 W | Prec 1% |
| R797 | 315-0562-00 | B220000 | | 5.6 k Ω | 1/4 W | 5% |
| R801 | 316-0100-00 | | | 10 Ω | 1/4 W | |
| R802 | 315-0100-00 | XB200000 | | 10 Ω | 1/4 W | 5% |
| R804B | 301-0914-00 | | | 910 k Ω | 1/2 W | 5% |
| R804C | 315-0114-00 | | | 110 k Ω | 1/4 W | 5% |
| R807 | 315-0563-00 | | | 56 k Ω | 1/4 W | 5% |
| R809 | 315-0104-00 | | | 100 k Ω | 1/4 W | 5% |
| R815 | 301-0105-00 | | | 1 M Ω | 1/2 W | 5% |
| R817 | 315-0105-00 | | | 1 M Ω | 1/4 W | 5% |
| R819 | 315-0180-00 | | | 18 Ω | 1/4 W | 5% |
| R823 | 316-0102-00 | | | 1 k Ω | 1/4 W | |
| R824 | 316-0151-00 | B010100 | B199999 | 150 Ω | 1/4 W | |
| R824 | 315-0101-00 | B200000 | | 100 Ω | 1/4 W | 5% |
| R828 | 315-0183-00 | | | 18 k Ω | 1/4 W | 5% |
| R829 | 315-0162-00 | | | 1.6 k Ω | 1/4 W | 5% |
| R833 | 315-0183-00 | | | 18 k Ω | 1/4 W | 5% |
| R835 | 315-0162-00 | | | 1.6 k Ω | 1/4 W | 5% |
| R836 | 315-0180-00 | XB260000 | | 18 Ω | 1/4 W | 5% |
| R837 | 315-0162-00 | | | 1.6 k Ω | 1/4 W | 5% |
| R838 | 315-0180-00 | XB260000 | | 18 Ω | 1/4 W | 5% |
| R840 | 315-0510-00 | | | 51 Ω | 1/4 W | 5% |
| R841 | 315-0113-00 | | | 11 k Ω | 1/4 W | 5% |
| R842 | 315-0133-00 | | | 13 k Ω | 1/4 W | 5% |
| R843 | 311-0510-00 | | | 10 k Ω , Var | | |
| R844 | 315-0272-00 | | | 2.7 k Ω | 1/4 W | 5% |
| R846 | 315-0331-00 | | | 330 Ω | 1/4 W | 5% |
| R848 | 315-0122-00 | | | 1.2 k Ω | 1/4 W | 5% |
| R849 ¹⁹ | 311-0553-00 | | | 10 k Ω , Var | | |
| R856 | 315-0360-00 | B010100 | B059999 | 36 Ω | 1/4 W | 5% |
| R856 | 317-0560-00 | B060000 | B069999 | 56 Ω | 1/8 W | 5% |
| R856 | 315-0131-00 | B070000 | | 130 Ω | 1/4 W | 5% |
| R857 | 315-0472-00 | | | 4.7 k Ω | 1/4 W | 5% |
| R858 | 315-0431-00 | | | 430 Ω | 1/4 W | 5% |
| R859 | 315-0100-00 | | | 10 Ω | 1/4 W | 5% |
| R864 | 301-0153-00 | B010100 | B029999 | 15 k Ω | 1/2 W | 5% |
| R864 | 301-0273-00 | B030000 | | 27 k Ω | 1/2 W | 5% |
| R866 | 317-0560-00 | | | 56 Ω | 1/8 W | 5% |
| R871 | 315-0103-00 | | | 10 k Ω | 1/4 W | 5% |
| R901 | 315-0101-00 | | | 100 Ω | 1/4 W | 5% |
| R902 | 315-0330-00 | | | 33 Ω | 1/4 W | 5% |
| R904 | 321-0159-00 | | | 442 Ω | 1/8 W | Prec 1% |
| R905 | 315-0103-00 | | | 10 k Ω | 1/4 W | 5% |

¹⁹Furnished as a unit with R762.

Electrical Parts List—Type 454/R454

Resistors (cont)

| Ckt. No. | Tektronix Part No. | Serial/Model No. Eff | No. Disc | Description | | |
|---------------------|--------------------|----------------------|------------|-------------|------|------|
| R911 | 315-0680-00 | | 68 Ω | 1/4 W | | 5% |
| R916 | 315-0102-00 | | 1 kΩ | 1/4 W | | 5% |
| R918 | 315-0333-00 | | 33 kΩ | 1/4 W | | 5% |
| R919 | 321-0261-00 | | 5.11 kΩ | 1/8 W | Prec | 1% |
| R920 | 321-0612-00 | | 500 Ω | 1/8 W | Prec | 1% |
| R921 | 321-0212-00 | | 1.58 kΩ | 1/8 W | Prec | 1% |
| R922 | 315-0220-00 | | 22 Ω | 1/4 W | | 5% |
| R923 | 315-0220-00 | | 22 Ω | 1/4 W | | 5% |
| R924 | 316-0100-00 | | 10 Ω | 1/4 W | | |
| R925 | 302-0681-00 | | 680 Ω | 1/2 W | | |
| R926 | 323-0149-00 | | 348 Ω | 1/2 W | Prec | 1% |
| R927 | 315-0620-00 | | 62 Ω | 1/4 W | | 5% |
| R929 | 316-0331-00 | | 330 Ω | 1/4 W | | |
| R930 | 316-0101-00 | | 100 Ω | 1/4 W | | |
| R931 | 315-0101-00 | | 100 Ω | 1/4 W | | 5% |
| R933 | 315-0622-00 | | 6.2 kΩ | 1/4 W | | 5% |
| R935 | 316-0470-00 | | 47 Ω | 1/4 W | | |
| R937 | 321-0256-00 | | 4.53 kΩ | 1/8 W | Prec | 1% |
| R938 | 321-0297-00 | | 12.1 kΩ | 1/8 W | Prec | 1% |
| R939 | 316-0272-00 | | 2.7 kΩ | 1/4 W | | |
| R940A | 323-0739-02 | | 157.4 kΩ | 1/2 W | Prec | 0.5% |
| R940C | 323-0739-02 | | 157.4 kΩ | 1/2 W | Prec | 0.5% |
| R940E | 323-0375-01 | | 78.7 kΩ | 1/2 W | Prec | 0.5% |
| R940F | 301-0225-00 | | 2.2 MΩ | 1/2 W | | 5% |
| R940G | 323-0584-00 | | 11.8 MΩ | 1/2 W | Prec | 1% |
| R940H | 323-0584-00 | | 11.8 MΩ | 1/2 W | Prec | 1% |
| R940J | 323-0567-00 | | 7.87 MΩ | 1/2 W | Prec | 1% |
| R940K | 323-0737-00 | | 3.935 MΩ | 1/2 W | Prec | 1% |
| R940M | 323-0738-01 | | 2.361 MΩ | 1/2 W | Prec | 0.5% |
| R940P | 323-0471-01 | | 787 kΩ | 1/2 W | Prec | 0.5% |
| R940R | 323-0471-07 | | 787 kΩ | 1/2 W | Prec | 0.1% |
| R940S ²⁰ | 311-0554-00 | | 20 kΩ, Var | | | |
| R940T | 315-0272-00 | | 2.7 kΩ | 1/4 W | | 5% |
| R940U | 315-0332-00 | | 3.3 kΩ | 1/4 W | | 5% |
| R943 | 311-0462-00 | | 1 kΩ, Var | | | |
| R945 | 308-0307-00 | | 5 kΩ | 3 W | WW | 1% |
| R946 | 316-0470-00 | | 47 Ω | 1/4 W | | |
| R947 | 303-0103-00 | | 10 kΩ | 1 W | | 5% |
| R948 | 315-0470-00 | | 47 Ω | 1/4 W | | 5% |
| R949 | 315-0680-00 | | 68 Ω | 1/4 W | | 5% |
| R951 | 316-0181-00 | | 180 Ω | 1/4 W | | |
| R953 | 321-0239-00 | | 3.01 kΩ | 1/8 W | Prec | 1% |
| R954 | 316-0220-00 | | 22 Ω | 1/4 W | | |
| R955 | 321-0296-00 | | 11.8 kΩ | 1/8 W | Prec | 1% |
| R956 | 311-0634-00 | | 500 Ω, Var | | | |
| R957 | 323-0294-00 | | 11.3 kΩ | 1/2 W | Prec | 1% |
| R958 | 321-0080-00 | | 66.5 Ω | 1/8 W | Prec | 1% |

²⁰Furnished as a unit with SW940S.

Resistors (cont)

| Ckt. No. | Tektronix Part No. | Serial/Model No. Eff | No. Disc | Description | | |
|----------------------|--------------------|----------------------|--|-----------------|------|----|
| R959 | 321-0126-00 | | 200 Ω | $\frac{1}{8}$ W | Prec | 1% |
| R960 | 315-0224-00 | | 220 k Ω | $\frac{1}{4}$ W | | 5% |
| R962 | 315-0303-00 | | 30 k Ω | $\frac{1}{4}$ W | | 5% |
| R963 | 315-0103-00 | | 10 k Ω | $\frac{1}{4}$ W | | 5% |
| R964 | 315-0103-00 | | 10 k Ω | $\frac{1}{4}$ W | | 5% |
| R965 | 315-0101-00 | | 100 Ω | $\frac{1}{4}$ W | | 5% |
| R966 | 321-0245-00 | | 3.48 k Ω | $\frac{1}{8}$ W | Prec | 1% |
| R967 | 315-0562-00 | | 5.6 k Ω | $\frac{1}{4}$ W | | 5% |
| R968 | 315-0101-00 | | 100 Ω | $\frac{1}{4}$ W | | 5% |
| R969 | 321-0223-00 | | 2.05 k Ω | $\frac{1}{8}$ W | Prec | 1% |
| R970 | 321-0226-00 | | 2.21 k Ω | $\frac{1}{8}$ W | Prec | 1% |
| R971 | 321-0179-00 | | 715 Ω | $\frac{1}{8}$ W | Prec | 1% |
| R973 | 321-0198-00 | | 1.13 k Ω | $\frac{1}{8}$ W | Prec | 1% |
| R975 | 321-0333-00 | | 28.7 k Ω | $\frac{1}{8}$ W | Prec | 1% |
| R977 | 321-0320-00 | | 21 k Ω | $\frac{1}{8}$ W | Prec | 1% |
| R978 | 321-0237-00 | | 2.87 k Ω | $\frac{1}{8}$ W | Prec | 1% |
| R980 | 301-0822-00 | | 8.2 k Ω | $\frac{1}{2}$ W | | 5% |
| R982 | 315-0751-00 | | 750 Ω | $\frac{1}{4}$ W | | 5% |
| R984 | 301-0622-00 | | 6.2 k Ω | $\frac{1}{2}$ W | | 5% |
| R985 | 315-0122-00 | | 1.2 k Ω | $\frac{1}{4}$ W | | 5% |
| R987 | 316-0471-00 | | 470 Ω | $\frac{1}{4}$ W | | |
| R990 | 315-0562-00 | | 5.6 k Ω | $\frac{1}{4}$ W | | 5% |
| R992 | 315-0152-00 | | 1.5 k Ω | $\frac{1}{4}$ W | | 5% |
| R993 | 301-0822-00 | | 8.2 k Ω | $\frac{1}{2}$ W | | 5% |
| R994 | 315-0122-00 | | 1.2 k Ω | $\frac{1}{4}$ W | | 5% |
| R996 | 316-0101-00 | | 100 Ω | $\frac{1}{4}$ W | | |
| R997 | 311-0386-00 | | 2 k Ω , Var | | | |
| R998 | 321-0177-00 | | 681 Ω | $\frac{1}{8}$ W | Prec | 1% |
| R999 | 321-0245-00 | | 3.48 k Ω | $\frac{1}{8}$ W | Prec | 1% |
| R1004 | 321-0034-00 | | 22.1 Ω | $\frac{1}{8}$ W | Prec | 1% |
| R1006A } R1006B } | 311-0542-01 | | 10 k Ω , Var 50 k Ω , Var | | | |
| R1007 | 315-0184-00 | | 180 k Ω | $\frac{1}{4}$ W | | 5% |
| R1008 | 315-0152-00 | | 1.5 k Ω | $\frac{1}{4}$ W | | 5% |
| R1009 | 315-0682-00 | | 6.8 k Ω | $\frac{1}{4}$ W | | 5% |
| R1011 | 321-0220-00 | | 1.91 k Ω | $\frac{1}{8}$ W | Prec | 1% |
| R1012 | 321-0231-00 | | 2.49 k Ω | $\frac{1}{8}$ W | Prec | 1% |
| R1014 | 303-0822-00 | | 8.2 k Ω | 1 W | | 5% |
| R1016 | 315-0470-00 | | 47 Ω | $\frac{1}{4}$ W | | 5% |
| R1017 | 323-0199-00 | | 1.15 k Ω | $\frac{1}{2}$ W | Prec | 1% |
| R1020 | 321-0001-00 | | 10 Ω | $\frac{1}{8}$ W | Prec | 1% |
| R1021 | 321-0241-00 | | 3.16 k Ω | $\frac{1}{8}$ W | Prec | 1% |
| R1022 | 321-0231-00 | | 2.49 k Ω | $\frac{1}{8}$ W | Prec | 1% |
| R1024 | 303-0822-00 | | 8.2 k Ω | 1 W | | 5% |
| R1033 | 321-0367-00 | | 64.9 k Ω | $\frac{1}{8}$ W | Prec | 1% |

Electrical Parts List—Type 454/R454

Resistors (cont)

| Kct. No. | Tektronix Part No. | Serial/Model No. Eff | No. Disc | Description | | | |
|----------|--------------------|----------------------|----------|-------------|-------|------|----|
| R1034 | 321-0247-00 | | | 3.65 kΩ | 1/8 W | Prec | 1% |
| R1035 | 323-0301-00 | | | 13.3 kΩ | 1/2 W | Prec | 1% |
| R1036 | 311-0609-00 | | | 2 kΩ, Var | | | |
| R1043 | 321-0367-00 | | | 64.9 kΩ | 1/8 W | Prec | 1% |
| R1044 | 321-0247-00 | | | 3.65 kΩ | 1/8 W | Prec | 1% |
| R1045 | 323-0301-00 | | | 13.3 kΩ | 1/2 W | Prec | 1% |
| R1046 | 321-0251-00 | B010100 | B010119 | 4.02 kΩ | 1/8 W | Prec | 1% |
| R1046 | 321-0257-00 | B010120 | | 4.64 kΩ | 1/8 W | Prec | 1% |
| R1047 | 311-0634-00 | | | 500 Ω, Var | | | |
| R1048 | 321-0161-00 | | | 464 Ω | 1/8 W | Prec | 1% |
| R1049 | 321-0154-00 | B010100 | B010119 | 392 Ω | 1/8 W | Prec | 1% |
| R1049 | 321-0149-00 | B010120 | | 348 Ω | 1/8 W | Prec | 1% |
| R1050 | 316-0154-00 | | | 150 kΩ | 1/4 W | | |
| R1051 | 315-0103-00 | | | 10 kΩ | 1/4 W | | 5% |
| R1053 | 311-0644-00 | | | 20 kΩ, Var | | | |
| R1055 | 315-0103-00 | | | 10 kΩ | 1/4 W | | 5% |
| R1061 | 321-0235-00 | | | 2.74 kΩ | 1/8 W | Prec | 1% |
| R1063 | 315-0122-00 | | | 1.2 kΩ | 1/4 W | | 5% |
| R1064 | 315-0623-00 | B010100 | B189999 | 62 kΩ | 1/4 W | | 5% |
| R1064 | 315-0393-00 | B190000 | | 39 kΩ | 1/4 W | | 5% |
| R1066 | 315-0391-00 | | | 390 Ω | 1/4 W | | 5% |
| R1071 | 321-0235-00 | | | 2.74 kΩ | 1/8 W | Prec | 1% |
| R1073 | 315-0122-00 | | | 1.2 kΩ | 1/4 W | | 5% |
| R1074 | 315-0623-00 | B010100 | B189999 | 62 kΩ | 1/4 W | | 5% |
| R1074 | 315-0393-00 | B190000 | | 39 kΩ | 1/4 W | | 5% |
| R1076 | 315-0391-00 | | | 390 Ω | 1/4 W | | 5% |
| R1081 | 323-0334-00 | | | 29.4 kΩ | 1/2 W | Prec | 1% |
| R1084 | 308-0363-00 | | | 3 kΩ | 8 W | WW | 5% |
| R1091 | 323-0334-00 | | | 29.4 kΩ | 1/2 W | Prec | 1% |
| R1094 | 308-0363-00 | | | 3 kΩ | 8 W | WW | 5% |
| R1104 | 316-0153-00 | | | 15 kΩ | 1/4 W | | |
| R1105 | 316-0472-00 | | | 4.7 kΩ | 1/4 W | | |
| R1106 | 316-0102-00 | | | 1 kΩ | 1/4 W | | |
| R1107 | 316-0330-00 | | | 33 Ω | 1/4 W | | |
| R1108 | 311-0548-00 | | | 25 Ω, Var | | | |
| R1112 | 316-0103-00 | | | 10 kΩ | 1/4 W | | |
| R1116 | 316-0101-00 | | | 100 Ω | 1/4 W | | |
| R1117 | 323-0154-00 | | | 392 Ω | 1/2 W | Prec | 1% |
| R1118 | 301-0273-00 | | | 27 kΩ | 1/2 W | | 5% |
| R1119 | 308-0244-00 | | | 0.3 Ω | 2 W | WW | |
| R1120 | 315-0561-00 | | | 560 Ω | 1/4 W | | 5% |
| R1123 | 321-0212-00 | | | 1.58 kΩ | 1/8 W | Prec | 1% |
| R1124 | 311-0515-00 | | | 250 Ω, Var | | | |
| R1125 | 321-0160-00 | | | 453 Ω | 1/8 W | Prec | 1% |
| R1137 | 315-0121-00 | | | 120 Ω | 1/4 W | | 5% |
| R1142 | 316-0103-00 | | | 10 kΩ | 1/4 W | | |
| R1149 | 308-0244-00 | | | 0.3 Ω | 2 W | WW | |

Resistors (cont)

| Ckt. No. | Tektronix Part No. | Serial/Model Eff | No. Disc | Description | | |
|----------|--------------------|------------------|----------|-------------|-------|------------|
| R1153 | 301-0243-00 | | | 24 kΩ | 1/2 W | 5% |
| R1155 | 316-0221-00 | | | 220 Ω | 1/4 W | |
| R1157 | 323-0205-00 | | | 1.33 kΩ | 1/2 W | Prec 1% |
| R1158 | 311-0514-00 | | | 100 Ω, Var | | |
| R1159 | 323-0205-00 | | | 1.33 kΩ | 1/2 W | Prec 1% |
| R1167 | 315-0121-00 | | | 120 Ω | 1/4 W | 5% |
| R1172 | 316-0104-00 | | | 100 kΩ | 1/4 W | |
| R1182 | 301-0123-00 | | | 12 kΩ | 1/2 W | 5% |
| R1183 | 315-0303-00 | | | 30 kΩ | 1/4 W | 5% |
| R1184 | 316-0102-00 | | | 1 kΩ | 1/4 W | |
| R1187 | 323-0308-00 | | | 15.8 kΩ | 1/2 W | Prec 1% |
| R1188 | 311-0515-00 | | | 250 Ω, Var | | |
| R1189 | 321-0230-00 | | | 2.43 kΩ | 1/8 W | Prec 1% |
| R1190 | 308-0103-00 | | | 2.5 kΩ | 5 W | WW 1% |
| R1192 | 315-0470-00 | | | 47 Ω | 1/4 W | 5% |
| R1193 | 321-0157-00 | | | 422 Ω | 1/8 W | Prec 1% |
| R1194 | 323-0345-00 | | | 38.3 kΩ | 1/2 W | Prec 1% |
| R1195 | 316-0102-00 | | | 1 kΩ | 1/4 W | |
| R1197 | 308-0365-00 | | | 1.5 Ω | 3 W | WW 5% |
| R1202 | 316-0104-00 | | | 100 kΩ | 1/4 W | |
| R1204 | 302-0270-00 | | | 27 Ω | 1/2 W | |
| R1224 | 315-0120-00 | | | 12 Ω | 1/4 W | 5% |
| R1228 | 323-0167-00 | | | 536 Ω | 1/2 W | Prec 1% |
| R1249 | 315-0470-00 | | | 47 Ω | 1/4 W | 5% |
| R1251 | 315-0471-00 | B010100 | B219999X | 470 Ω | 1/4 W | 5% |
| R1252 | 307-0106-00 | | | 4.7 Ω | 1/4 W | 5% |
| R1254 | 307-0106-00 | | | 4.7 Ω | 1/4 W | 5% |
| R1256 | 316-0101-00 | | | 100 Ω | 1/4 W | |
| R1257 | 315-0220-00 | | | 22 Ω | 1/4 W | 5% |
| R1258 | 315-0470-00 | | | 47 Ω | 1/4 W | 5% |
| R1259 | 315-0220-00 | | | 22 Ω | 1/4 W | 5% |
| R1262 | 307-0106-00 | | | 4.7 Ω | 1/4 W | 5% |
| R1264 | 307-0106-00 | | | 4.7 Ω | 1/4 W | 5% |
| R1267 | 315-0470-00 | | | 47 Ω | 1/4 W | 5% |
| R1271 | 315-0120-00 | | | 12 Ω | 1/4 W | 5% |
| R1274 | 316-0471-00 | | | 470 Ω | 1/4 W | |
| R1275 | 315-0472-00 | | | 4.7 Ω | 1/4 W | 5% |
| R1284 | 316-0222-00 | | | 2.2 kΩ | 1/4 W | |
| R1285 | 315-0682-00 | | | 6.8 kΩ | 1/4 W | 5% |
| R1286 | 316-0471-00 | | | 470 Ω | 1/4 W | |
| R1296 | 321-0649-00 | | | 2.19 kΩ | 1/8 W | Prec 0.25% |
| R1298 | 322-0126-06 | | | 200 Ω | 1/4 W | Prec 0.25% |
| R1299 | 321-1080-01 | | | 67.3 Ω | 1/8 W | Prec 0.5% |
| R1301 | 311-0511-00 | | | 10 kΩ, Var | | |
| R1303 | 315-0123-00 | | | 12 kΩ | 1/4 W | 5% |

Electrical Parts List—Type 454/R454

Resistors (cont)

| Ckt. No. | Tektronix Part No. | Serial/Model No. | | Description | | |
|----------|--------------------|------------------|-------------|-------------|------|----|
| | | Eff | Disc | | | |
| R1304 | 315-0123-00 | | 12 kΩ | 1/4 W | | 5% |
| R1305 | 321-0241-00 | | 3.16 kΩ | 1/8 W | Prec | 1% |
| R1307 | 316-0470-00 | | 47 Ω | 1/4 W | | |
| R1308 | 301-0473-00 | | 47 kΩ | 1/2 W | | 5% |
| R1309 | 316-0470-00 | | 47 Ω | 1/4 W | | |
| R1311 | 316-0471-00 | | 470 Ω | 1/4 W | | |
| R1312 | 323-0318-00 | | 20 kΩ | 1/2 W | Prec | 1% |
| R1315 | 321-0241-00 | | 3.16 kΩ | 1/8 W | Prec | 1% |
| R1316 | 316-0101-00 | | 100 Ω | 1/4 W | | |
| R1320 | 315-0221-00 | | 220 Ω | 1/4 W | | 5% |
| R1321 | 315-0390-00 | | 39 Ω | 1/4 W | | 5% |
| R1324 | 316-0102-00 | | 1 kΩ | 1/4 W | | |
| R1326 | 301-0243-00 | | 24 kΩ | 1/2 W | | 5% |
| R1327 | 315-0240-00 | | 24 Ω | 1/2 W | | 5% |
| R1330 | 315-0121-00 | | 120 Ω | 1/4 W | | 5% |
| R1332 | 301-0751-00 | | 750 Ω | 1/2 W | | 5% |
| R1333 | 316-0470-00 | | 47 Ω | 1/4 W | | |
| R1344 | 301-0680-00 | | 68 Ω | 1/2 W | | 5% |
| R1345 | 305-0822-00 | | 8.2 kΩ | 2 W | | 5% |
| R1346 | 316-0101-00 | | 100 Ω | 1/4 W | | |
| R1351 | 323-0335-00 | | 30.1 kΩ | 1/2 W | Prec | 1% |
| R1353 | 316-0101-00 | | 100 Ω | 1/4 W | | |
| R1354 | 305-0183-00 | | 18 kΩ | 2 W | | 5% |
| R1357 | 316-0101-00 | | 100 Ω | 1/4 W | | |
| R1358 | 308-0348-00 | | 3.32 kΩ | 3 W | WW | 1% |
| R1401 | 311-0465-00 | | 100 kΩ, Var | | | |
| R1402 | 301-0435-00 | | 4.3 MΩ | 1/2 W | | 5% |
| R1403 | 315-0204-00 | | 200 kΩ | 1/4 W | | 5% |
| R1404 | 301-0105-00 | | 1 MΩ | 1/2 W | | 5% |
| R1405 | 301-0305-00 | | 3 MΩ | 1/2 W | | 5% |
| R1406 | 301-0305-00 | | 3 MΩ | 1/2 W | | 5% |
| R1407 | 301-0305-00 | | 3 MΩ | 1/2 W | | 5% |
| R1408 | 301-0305-00 | | 3 MΩ | 1/2 W | | 5% |
| R1409 | 301-0305-00 | | 3 MΩ | 1/2 W | | 5% |
| R1410 | 301-0305-00 | | 3 MΩ | 1/2 W | | 5% |
| R1411 | 301-0305-00 | | 3 MΩ | 1/2 W | | 5% |
| R1412 | 301-0305-00 | | 3 MΩ | 1/2 W | | 5% |
| R1414 | 316-0103-00 | | 10 kΩ | 1/4 W | | |
| R1415 | 316-0102-00 | | 1 kΩ | 1/4 W | | |
| R1416 | 315-0474-00 | | 470 kΩ | 1/4 W | | 5% |
| R1417 | 316-0101-00 | | 100 Ω | 1/4 W | | |
| R1418 | 316-0104-00 | | 100 kΩ | 1/4 W | | |
| R1425 | 301-0303-00 | | 30 kΩ | 1/2 W | | 5% |
| R1441 | 301-0103-00 | | 10 kΩ | 1/2 W | | 5% |
| R1442 | 301-0106-00 | | 10 MΩ | 1/2 W | | 5% |

Resistors (cont)

| Kct. No. | Tektronix Part No. | Serial/Model No. Eff | Disc | Description | |
|----------|--------------------|----------------------|------|-------------|-------------|
| R1443 | 301-0106-00 | | | 10 MΩ | 1/2 W 5% |
| R1444 | 301-0106-00 | | | 10 MΩ | 1/2 W 5% |
| R1445 | 301-0106-00 | | | 10 MΩ | 1/2 W 5% |
| R1446 | 301-0106-00 | | | 10 MΩ | 1/2 W 5% |
| R1447 | 311-0657-00 | | | 2 MΩ, Var | |
| R1448 | 301-0755-00 | | | 7.5 MΩ | 1/2 W 5% |
| R1449 | 316-0105-00 | | | 1 MΩ | 1/4 W |
| R1450 | 308-0427-00 | | | 9.3 Ω | 1/2 W WW 1% |
| R1458 | 301-0103-00 | | | 10 kΩ | 1/2 W 5% |
| R1460 | 316-0105-00 | | | 1 MΩ | 1/4 W |
| R1461 | 316-0105-00 | | | 1 MΩ | 1/4 W |
| R1463 | 301-0335-00 | | | 3.3 MΩ | 1/2 W 5% |
| R1464 | 301-0335-00 | | | 3.3 MΩ | 1/2 W 5% |
| R1465 | 301-0335-00 | | | 3.3 MΩ | 1/2 W 5% |
| R1466 | 301-0335-00 | | | 3.3 MΩ | 1/2 W 5% |
| R1467 | 311-0254-00 | | | 5 MΩ, Var | |
| R1468 | 301-0106-00 | | | 10 MΩ | 1/2 W 5% |
| R1469 | 301-0155-00 | | | 1.5 MΩ | 1/2 W 5% |
| R1471 | 301-0183-00 | | | 18 kΩ | 1/2 W 5% |
| R1472 | 301-0223-00 | | | 22 kΩ | 1/2 W 5% |
| R1476 | 301-0103-00 | | | 10 kΩ | 1/2 W 5% |
| R1477 | 316-0470-00 | | | 47 Ω | 1/4 W |
| R1479 | 315-0221-00 | | | 220 Ω | 1/4 W 5% |
| R1480 | 311-0458-00 | | | 5 kΩ, Var | |
| R1482 | 311-0465-00 | | | 100 kΩ, Var | |
| R1485 | 311-0458-00 | | | 5 kΩ, Var | |
| R1489 | 311-0580-00 | | | 50 kΩ, Var | |

Switches

Unwired or Wired

| | | | | | |
|---------------------|--------------------|---------|---------|--------|----------------|
| SW1 | 260-0621-00 | | | Lever | CH 1 AC GND DC |
| SW5 ²¹ | | | | Rotary | CH 1 VOLTS/DIV |
| SW60 ²² | 311-0638-00 | | | | CH 1 VARIABLE |
| SW101 | 260-0621-00 | | | Lever | CH 2 AC GND DC |
| SW105 ²¹ | | | | Rotary | CH 2 VOLTS/DIV |
| SW160 ²³ | 311-0638-00 | | | | CH 2 VARIABLE |
| SW181 | 260-0723-00 | | | Slide | INVERT PULL |
| SW238 | Wired *262-0797-00 | | | Rotary | MODE |
| SW238 | 260-0695-00 | B010100 | B010119 | Rotary | MODE |
| SW238 | 260-0695-01 | B010120 | | Rotary | MODE |

²¹See Mechanical Parts List for replacement assembly.

²²Furnished as a unit with R60A,B.

²³Furnished as a unit with R160A,B.

Electrical Parts List—Type 454/R454

Switches (cont)

| Ckt. No. | Tektronix Part No. | Serial/Model No. Eff | Disc | Description |
|-------------------------|--------------------|----------------------|---------------------|--------------------------|
| Unwired or Wired | | | | |
| SW345 | 260-0838-00 | | | Lever BEAM FINDER |
| SW602 | Wired *262-0800-00 | B010100 | B199999 | Lever A SOURCE |
| SW608 | | | | Lever A COUPLING |
| SW602 | | | | Lever A SOURCE |
| SW608 | Wired *262-0800-01 | B200000 | B219999 | Lever A COUPLING |
| SW602 | | | | Lever A SOURCE |
| SW608 | Wired *262-0800-02 | B220000 | | Lever A COUPLING |
| SW602 | | | Lever A SOURCE | |
| SW602 | 260-0698-01 | | | Lever A SOURCE |
| SW608 | 260-0827-00 | | | Lever A COUPLING |
| SW650 | 260-0472-00 | | | Lever A SLOPE |
| SW740S ²³ | 311-0554-00 | | | A CAL |
| SW750A,B | Wired *262-0801-00 | | | Rotary TIME/DIV |
| SW750A,B | 260-0823-00 | | | Rotary TIME/DIV |
| SW765 | Wired *262-0799-00 | | | Rotary A SWEEP LENGTH |
| SW765 | | 260-0825-00 | | Rotary A SWEEP LENGTH |
| SW780 | 260-0699-00 | | | Lever A SWEEP MODE |
| SW783 ²⁴ | 260-0717-00 | | | Push RESET |
| SW802 | Wired *262-0800-00 | B010100 | B199999 | Lever B SOURCE |
| SW808 | | | | Lever B COUPLING |
| SW802 | Wired *262-0800-01 | B200000 | B219999 | Lever B SOURCE |
| SW808 | | | | Lever B COUPLING |
| SW802 | Wired *262-0800-02 | B220000 | | Lever B SOURCE |
| SW808 | | | Lever B COUPLING | |
| SW802 | 260-0698-01 | | | Lever B SOURCE |
| SW808 | 260-0827-00 | | | Lever B COUPLING |
| SW835 | 260-0587-00 | | | Lever B SWEEP MODE |
| SW850 | 260-0472-00 | | | Lever B SLOPE |
| SW940S ²⁵ | 311-0554-00 | | | B CAL |
| SW1001A | 260-0826-00 | | | Rotary HORIZ DISPLAY |
| SW1001B | | Rotary MAG | | |
| SW1101 | 260-0834-00 | | | Toggle POWER |
| SW1102 ²⁶ | | | | |
| SW1103 ²⁶ | | | | |

Thermal Cut-Out

| | | |
|--------|-------------|---------------------------|
| TK1101 | 260-0879-00 | Open 191 °F; Close 161 °F |
|--------|-------------|---------------------------|

Transformers

| | | | | |
|------|--------------|----------|----------|--------------------|
| T240 | *120-0384-00 | | | Toroid, 2 windings |
| T358 | *120-0469-00 | | | Toroid, 3 turns |
| T550 | 276-0525-00 | B010100 | B219999X | Core, Ferrite |
| T556 | 276-0525-00 | B010100 | B219999X | Core, Ferrite |
| T610 | 276-0525-00 | XB220000 | | Core, Ferrite |

²³Furnished as a unit with R740S.

²⁴Furnished as a unit with B792.

²⁵Furnished as a unit with R940S.

²⁶See Mechanical Parts List. Line Voltage Selector Body.

Transformers (cont)

| Ckt. No. | Tektronix Part No. | Serial/Model No. | | Description |
|----------|--------------------|------------------|---------|--|
| | | Eff | Disc | |
| T670 | *120-0467-00 | B010100 | B069999 | Toroid, 6 turns - 6 turns - 3 turns trifilar |
| T670 | *120-0551-00 | B070000 | B219999 | Toroid, 6 turns trifilar |
| T670 | *120-0617-00 | B220000 | | Toroid, 6 turns - 3 turns bifilar |
| T680 | *120-0468-00 | | | Toroid, 6 turns bifilar |
| T810 | 276-0525-00 | | | Core, Ferrite |
| T870 | *120-0468-00 | | | Toroid, 6 turns bifilar |
| T1101 | *120-0470-00 | | | L. V. Power |
| T1275 | *120-0460-00 | | | Cal. Freq. |
| T1430 | *120-0471-00 | | | H. V. Power |

Test Points

| | | | | |
|--------|--------------|--|--|-----------------|
| TP636 | *214-0579-00 | | | Pin, Test Point |
| TP646 | *214-0579-00 | | | Pin, Test Point |
| TP656 | *214-0579-00 | | | Pin, Test Point |
| TP701 | *214-0579-00 | | | Pin, Test Point |
| TP715 | *214-0579-00 | | | Pin, Test Point |
| TP722 | *214-0579-00 | | | Pin, Test Point |
| TP775 | *214-0579-00 | | | Pin, Test Point |
| TP836 | *214-0579-00 | | | Pin, Test Point |
| TP846 | *214-0579-00 | | | Pin, Test Point |
| TP856 | *214-0579-00 | | | Pin, Test Point |
| TP902 | *214-0579-00 | | | Pin, Test Point |
| TP918 | *214-0579-00 | | | Pin, Test Point |
| TP945 | *214-0579-00 | | | Pin, Test Point |
| TP970 | *214-0579-00 | | | Pin, Test Point |
| TP979 | *214-0579-00 | | | Pin, Test Point |
| TP990 | *214-0579-00 | | | Pin, Test Point |
| TP1314 | *214-0579-00 | | | Pin, Test Point |
| TP1349 | *214-0579-00 | | | Pin, Test Point |
| TP1415 | *214-0579-00 | | | Pin, Test Point |

Electron Tubes

| | | | | |
|-------|--------------|--|--|----------------------------------|
| V13 | *157-0107-00 | | | 8393, Nuovistor, aged |
| V113 | *157-0107-00 | | | 8393, Nuovistor, aged |
| V623 | 154-0461-00 | | | 8393, Nuovistor |
| V733 | 154-0461-00 | | | 8393, Nuovistor |
| V823 | 154-0461-00 | | | 8393, Nuovistor |
| V933 | 154-0461-00 | | | 8393, Nuovistor |
| V1479 | *154-0505-00 | | | T4540-31-1 CRT Standard Phosphor |

FIGURE AND INDEX NUMBERS

Items in this section are referenced by figure and index numbers to the illustrations which appear on the pullout pages immediately following the Diagrams section of this instruction manual.

INDENTATION SYSTEM

This mechanical parts list is indented to indicate item relationships. Following is an example of the indentation system used in the Description column.

Assembly and/or Component
Detail Part of Assembly and/or Component
mounting hardware for Detail Part
Parts of Detail Part
mounting hardware for Parts of Detail Part
mounting hardware for Assembly and/or Component

Mounting hardware always appears in the same indentation as the item it mounts, while the detail parts are indented to the right. Indented items are part of, and included with, the next higher indentation.

Mounting hardware must be purchased separately, unless otherwise specified.

PARTS ORDERING INFORMATION

Replacement parts are available from or through your local Tektronix, Inc. Field Office or representative.

Changes to Tektronix instruments are sometimes made to accommodate improved components as they become available, and to give you the benefit of the latest circuit improvements developed in our engineering department. It is therefore important, when ordering parts, to include the following information in your order: Part number, instrument type or number, serial or model number, and modification number if applicable.

If a part you have ordered has been replaced with a new or improved part, your local Tektronix, Inc. Field Office or representative will contact you concerning any change in part number.

Change information, if any, is located at the rear of this manual.

ABBREVIATIONS AND SYMBOLS

For an explanation of the abbreviations and symbols used in this section, please refer to the page immediately preceding the Electrical Parts List in this instruction manual.

INDEX OF MECHANICAL PARTS LIST ILLUSTRATIONS

(Located behind diagrams)

FIG. 1 FRONT

FIG. 2 ATTENUATOR ASSEMBLY & A and B TIME/DIV and DELAY TIME SWITCH

FIG. 3 CRT & SHIELD ASSEMBLY

FIG. 4 A SWEEP, B SWEEP & HIGH-VOLTAGE SUPPLY

FIG. 5 REAR CHASSIS

FIG. 6 FRAME & CABINET

FIG. 7 R454 MECHANICAL PARTS

FIG. 8 454/R454 ACCESSORIES and OTHER PARTS FURNISHED WITH R454

SECTION 8

MECHANICAL PARTS LIST

FIG. 1 FRONT

| Fig. & Index No. | Tektronix Part No. | Serial/Model Eff | No. Disc | Q | | | | | Description | |
|------------------------|-----------------------|---------------------|-------------|---|---|---|---|---|-------------|--|
| | | | | t | y | 1 | 2 | 3 | | 4 |
| 1-1 | 366-0153-00 | | | 1 | | | | | | KNOB, charcoal—INTENSITY |
| | - - - - - | | | - | | | | | | knob includes: |
| | 213-0004-00 | | | 1 | | | | | | SCREW, set, 6-32 x 3/16 inch, HSS |
| -2 | - - - - - | | | 1 | | | | | | RESISTOR, variable |
| | - - - - - | | | - | | | | | | mounting hardware: (not included w/resistor) |
| -3 | 210-0583-00 | | | 2 | | | | | | NUT, hex., 1/4-32 x 5/16 inch |
| -4 | 210-0046-00 | | | 1 | | | | | | LOCKWASHER, internal, 1/4 ID x 0.400 inch OD |
| -5 | 210-0940-00 | | | 1 | | | | | | WASHER, flat, 1/4 ID x 3/8 inch OD |
| -6 | 366-0153-00 | | | 1 | | | | | | KNOB, charcoal—FOCUS |
| | - - - - - | | | - | | | | | | knob includes: |
| | 213-0004-00 | | | 1 | | | | | | SCREW, set, 6-32 x 3/16 inch, HSS |
| -7 | - - - - - | | | 1 | | | | | | RESISTOR, variable |
| | - - - - - | | | - | | | | | | mounting hardware: (not included w/resistor) |
| | 210-0046-00 | | | 1 | | | | | | LOCKWASHER, internal, 1/4 ID x 0.400 inch OD |
| | 210-0940-00 | | | 1 | | | | | | WASHER, flat, 1/4 ID x 3/8 inch OD |
| -8 | 210-0583-00 | | | 2 | | | | | | NUT, hex., 1/4-32 x 5/16 inch |
| -9 | 366-0153-00 | | | 1 | | | | | | KNOB, charcoal—SCALE ILLUM |
| | - - - - - | | | - | | | | | | knob includes: |
| | 213-0004-00 | | | 1 | | | | | | SCREW, set, 6-32 x 3/16 inch, HSS |
| -10 | - - - - - | | | 1 | | | | | | RESISTOR, variable |
| | - - - - - | | | - | | | | | | mounting hardware: (not included w/resistor) |
| | 210-0046-00 | | | 1 | | | | | | LOCKWASHER, internal, 1/4 ID x 0.400 inch OD |
| | 210-0940-00 | | | 1 | | | | | | WASHER, flat, 1/4 ID x 3/8 inch OD |
| -11 | 210-0583-00 | | | 2 | | | | | | NUT, hex., 1/4-32 x 5/16 inch |
| -12 | 366-0189-00 | | | 1 | | | | | | KNOB, red—VARIABLE (CH 1) |
| | - - - - - | | | - | | | | | | knob includes: |
| | 213-0020-00 | | | 1 | | | | | | SCREW, set, 6-32 x 1/8 inch, HSS |
| -13 | 366-0322-00 | | | 1 | | | | | | KNOB, charcoal—VOLTS/DIV (CH 1) |
| | - - - - - | | | - | | | | | | knob includes: |
| | 213-0004-00 | | | 1 | | | | | | SCREW, set, 6-32 x 3/16 inch, HSS |
| -14 | 366-0153-00 | | | 1 | | | | | | KNOB, charcoal—POSITION (CH 1) |
| | - - - - - | | | - | | | | | | knob includes: |
| | 213-0004-00 | | | 1 | | | | | | SCREW, set, 6-32 x 3/16 inch, HSS |
| -15 | 366-0189-00 | | | 1 | | | | | | KNOB, red—VARIABLE (CH 2) |
| | - - - - - | | | - | | | | | | knob includes: |
| | 213-0020-00 | | | 1 | | | | | | SCREW, set, 6-32 x 1/8 inch, HSS |
| -16 | 366-0322-00 | | | 1 | | | | | | KNOB, charcoal—VOLTS/DIV (CH 2) |
| | - - - - - | | | - | | | | | | knob includes: |
| | 213-0004-00 | | | 1 | | | | | | SCREW, set, 6-32 x 3/16 inch, HSS |
| -17 | 366-0153-00 | | | 1 | | | | | | KNOB, charcoal—POSITION (CH 2) |
| | - - - - - | | | - | | | | | | knob includes: |
| | 213-0004-00 | | | 1 | | | | | | SCREW, set, 6-32 x 1/8 inch, HSS |

FIG. 1 FRONT (cont)

| Fig. & Index No. | Tektronix Part No. | Serial/Model Eff | No. Disc | Q t y | | | | | | Description |
|------------------------|-----------------------|---------------------|-------------|-------------|---|---|---|---|---|--|
| | | | | | 1 | 2 | 3 | 4 | 5 | |
| 1-18 | 366-0189-00 | | | 1 | | | | | | KNOB, red—TRIGGER |
| | - - - - - | | | - | | | | | | knob includes: |
| | 213-0020-00 | | | 1 | | | | | | SCREW, set, 6-32 x 1/8 inch, HSS |
| -19 | 366-0322-00 | | | 1 | | | | | | KNOB, charcoal—MODE |
| | - - - - - | | | - | | | | | | knob includes: |
| | 213-0004-00 | | | 1 | | | | | | SCREW, set, 6-32 x 3/16 inch, HSS |
| -20 | 366-0215-01 | | | 1 | | | | | | KNOB, charcoal—AC GND DC (CH 1) |
| -21 | 366-0215-01 | | | 1 | | | | | | KNOB, charcoal—AC GND DC (CH 2) |
| -22 | 366-0038-00 | | | 1 | | | | | | KNOB, red—A VARIABLE |
| | - - - - - | | | - | | | | | | knob includes: |
| | 213-0004-00 | | | 1 | | | | | | SCREW, set, 6-32 x 3/16 inch, HSS |
| -23 | 366-0194-00 | | | 1 | | | | | | KNOB, charcoal— B TIME/DIV |
| | - - - - - | | | - | | | | | | knob includes: |
| | 213-0022-00 | | | 1 | | | | | | SCREW, set, 4-40 x 3/16 inch, HSS |
| -24 | 331-0092-00 | | | 1 | | | | | | DIAL, window knob—A TIME/DIV |
| | - - - - - | | | - | | | | | | dial includes: |
| | 213-0022-00 | | | 2 | | | | | | SCREW, set, 4-40 x 3/16 inch, HSS |
| -25 | 331-0139-00 | | | 1 | | | | | | DIAL—DELAY TIME MULTIPLIER |
| | - - - - - | | | - | | | | | | dial includes: |
| | 213-0048-00 | | | 1 | | | | | | SCREW, set, 4-40 x 1/8 inch, HSS |
| -26 | - - - - - | | | 1 | | | | | | RESISTOR, variable |
| | - - - - - | | | - | | | | | | mounting hardware: (not included w/resistor) |
| | 210-0012-00 | | | 1 | | | | | | LOCKWASHER, internal, 3/8 ID x 1/2 inch OD |
| -27 | 366-0220-00 | | | 1 | | | | | | KNOB, charcoal—LEVEL (B TRIGGERING) |
| | - - - - - | | | - | | | | | | knob includes: |
| | 213-0020-00 | | | 1 | | | | | | SCREW, set, 6-32 x 1/8 inch, HSS |
| -28 | - - - - - | | | 1 | | | | | | RESISTOR, variable |
| | - - - - - | | | - | | | | | | mounting hardware (not included w/resistor) |
| | 210-0012-00 | | | 1 | | | | | | LOCKWASHER, internal, 3/8 ID x 1/2 inch OD |
| | 210-0978-00 | | | 1 | | | | | | WASHER, flat, 3/8 ID x 1/2 inch OD |
| -29 | 210-0590-00 | | | 1 | | | | | | NUT, hex., 3/8-32 x 7/16 inch |
| -30 | 366-0148-00 | | | 1 | | | | | | KNOB, charcoal—A SWEEP LENGTH |
| | - - - - - | | | - | | | | | | knob includes: |
| | 213-0004-00 | | | 1 | | | | | | SCREW, set, 6-32 x 3/16 inch, HSS |
| -31 | 262-0799-00 | | | 1 | | | | | | SWITCH, wired—A SWEEP LENGTH |
| | - - - - - | | | - | | | | | | switch includes: |
| | 260-0825-00 | | | 1 | | | | | | SWITCH, unwired |
| -32 | 376-0014-00 | | | 1 | | | | | | COUPLING |
| | 131-0371-00 | | | 2 | | | | | | CONNECTOR, single contact (not shown) |
| -33 | - - - - - | | | 1 | | | | | | RESISTOR, variable |
| | - - - - - | | | - | | | | | | mounting hardware: (not included w/resistor) |
| -34 | 210-0590-00 | | | 2 | | | | | | NUT, hex., 3/8-32 x 7/16 inch |
| -35 | 210-0012-00 | | | 1 | | | | | | LOCKWASHER, internal, 3/8 ID x 1/2 OD |
| | - - - - - | | | - | | | | | | mounting hardware: (not included w/switch) |
| -36 | 210-0978-00 | | | 1 | | | | | | WASHER, flat, 3/8 ID x 1/2 inch OD |
| -37 | 210-0590-00 | | | 1 | | | | | | NUT, hex., 3/8-32 x 7/16 inch |

FIG. 1 FRONT (cont)

| Fig. & Index No. | Tektronix Part No. | Serial/Model No. | | Q f y | Description |
|------------------------|-----------------------|------------------|----------|-------------|--|
| | | Eff | Disc | | |
| 1-38 | 366-0189-00 | | | 1 | KNOB, red—MAG |
| | - - - - - | | | - | knob includes: |
| | 213-0020-00 | | | 1 | SCREW, set, 6-32 x 1/8 inch, HSS |
| -39 | 366-0322-00 | | | 1 | KNOB, charcoal—HORIZ DISPLAY |
| | - - - - - | | | - | knob includes: |
| | 213-0004-00 | | | 1 | SCREW, set, 6-32 x 3/16 inch, HSS |
| -40 | 260-0826-00 | | | 1 | SWITCH, unwired—HORIZ DISPLAY |
| | - - - - - | | | - | mounting hardware: (not included w/switch) |
| | 210-0978-00 | | | 1 | WASHER, flat, 3/8 ID x 1/2 inch OD |
| -41 | 210-0590-00 | | | 1 | NUT, hex., 3/8-32 x 7/16 inch |
| | - - - - - | | | | |
| -42 | 366-0319-00 | | | 1 | KNOB, red—FINE |
| | - - - - - | | | - | knob includes: |
| | 213-0020-00 | | | 1 | SCREW, set, 6-32 x 1/8 inch, HSS |
| -43 | 366-0138-00 | | | 1 | KNOB, charcoal—POSITION |
| | - - - - - | | | - | knob includes: |
| | 213-0004-00 | | | 1 | SCREW, set, 6-32 x 3/16 inch, HSS |
| -44 | - - - - - | | | 1 | RESISTOR, variable |
| | - - - - - | | | - | mounting hardware: (not included w/resistor) |
| -45 | 210-0013-00 | B010100 | B091789 | 1 | LOCKWASHER, internal, 3/8 ID x 11/16 inch OD |
| | 210-0012-00 | B091790 | B153499X | 1 | LOCKWASHER, internal, 3/8 ID x 1/2 inch OD |
| -46 | 210-0255-00 | | | 1 | LUG, solder, 3/8 inch |
| | 210-0494-00 | B010100 | B153499 | 1 | NUT, hex., 3/8-32 x 1/2 x 11/16 inch |
| | 129-0167-00 | B153500 | | 1 | POST, metallic |
| | 210-0840-00 | | | 1 | WASHER, flat, 0.390 ID x 9/16 inch OD |
| -47 | 358-0029-05 | | | 1 | BUSHING, hex., 1/2 inch long |
| | - - - - - | | | | |
| -48 | 366-0319-00 | | | 1 | KNOB, red—HF STAB |
| | - - - - - | | | - | knob includes: |
| | 213-0020-00 | | | 1 | SCREW, set, 6-32 x 1/8 inch, HSS |
| -49 | 366-0138-00 | | | 1 | KNOB, charcoal—LEVEL (A TRIGGERING) |
| | - - - - - | | | - | knob includes: |
| | 213-0004-00 | | | 1 | SCREW, set, 6-32 x 3/16 inch, HSS |
| -50 | - - - - - | | | 1 | RESISTOR, variable |
| | - - - - - | | | - | mounting hardware: (not included w/resistor) |
| | 210-0012-00 | | | 1 | LOCKWASHER, internal, 3/8 ID x 1/2 inch OD |
| | 210-0978-00 | | | 1 | WASHER, flat, 3/8 ID x 1/2 inch OD |
| -51 | 210-0590-00 | | | 1 | NUT, hex., 3/8-32 x 7/16 inch |
| | - - - - - | | | | |
| -52 | 366-0215-01 | | | 1 | KNOB, charcoal—SLOPE (A TRIGGERING) |
| -53 | 260-0472-00 | | | 1 | SWITCH, lever—SLOPE |
| | - - - - - | | | - | mounting hardware: (not included w/switch) |
| -54 | 220-0413-00 | | | 2 | NUT, switch, 4-40 x 3/16 x 0.562 inch |

FIG. 1 FRONT (cont)

| Fig. & Index No. | Tektronix Part No. | Serial/Model No. | | Q † Y | Description |
|------------------|--------------------|------------------|---------|-------------|---|
| | | Eff | Disc | | |
| 1-55 | 366-0215-01 | | | 1 | KNOB, charcoal—COUPLING (A TRIGGERING) |
| -56 | 366-0215-01 | | | 1 | KNOB, charcoal—SOURCE (A TRIGGERING) |
| -57 | 262-0800-00 | B010100 | B199999 | 1 | SWITCH, wired—COUPLING & SOURCE |
| | 262-0800-01 | B200000 | B219999 | 1 | SWITCH, wired—COUPLING & SOURCE |
| | 262-0800-02 | B220000 | | 1 | SWITCH, wired—COUPLING & SOURCE |
| | - - - - - | | | - | switch includes: |
| -58 | 260-0827-00 | | | 1 | SWITCH, lever—COUPLING |
| -59 | 260-0698-01 | | | 1 | SWITCH, lever—SOURCE |
| | - - - - - | | | - | mounting hardware: (not included w/switch) |
| | 220-0413-00 | | | 4 | NUT, switch, 4-40 x 3/16 x 0.562 inch (not shown) |
| -60 | 366-0215-01 | | | 1 | KNOB, charcoal—A SWEEP MODE |
| -61 | 260-0699-00 | | | 1 | SWITCH, lever—A SWEEP MODE |
| | - - - - - | | | - | mounting hardware: (not included w/switch) |
| | 220-0413-00 | | | 2 | NUT, switch, 4-40 x 3/16 x 0.562 inch (not shown) |
| -62 | 366-0215-01 | | | 1 | KNOB, charcoal—B SWEEP MODE |
| -63 | 260-0587-00 | | | 1 | SWITCH, lever—B SWEEP MODE |
| | - - - - - | | | - | mounting hardware: (not included w/switch) |
| | 220-0413-00 | | | 2 | NUT, switch, 4-40 x 3/16 x 0.562 inch (not shown) |
| -64 | 366-0215-01 | | | 1 | KNOB, charcoal—SLOPE (B TRIGGERING) |
| -65 | 260-0472-00 | | | 1 | SWITCH, lever—SLOPE |
| | - - - - - | | | - | mounting hardware: (not included w/switch) |
| | 220-0413-00 | | | 2 | NUT, switch, 4-40 x 3/16 x 0.562 inch (not shown) |
| -66 | 366-0215-01 | | | 1 | KNOB, charcoal—COUPLING (B TRIGGERING) |
| -67 | 366-0215-01 | | | 1 | KNOB, charcoal—SOURCE (B TRIGGERING) |
| -68 | 262-0800-00 | B010100 | B199999 | 1 | SWITCH, wired—COUPLING & SOURCE |
| | 262-0800-01 | B200000 | B219999 | 1 | SWITCH, wired—COUPLING & SOURCE |
| | 262-0800-02 | B220000 | | 1 | SWITCH, wired—COUPLING & SOURCE |
| | - - - - - | | | - | switch includes: |
| -69 | 260-0827-00 | | | 1 | SWITCH, lever—COUPLING |
| -70 | 260-0698-01 | | | 1 | SWITCH, lever—SOURCE |
| | - - - - - | | | - | mounting hardware: (not included w/switch) |
| | 220-0413-00 | | | 4 | NUT, switch, 4-40 x 3/16 x 0.562 inch (not shown) |
| -71 | 260-0834-00 | | | 1 | SWITCH, toggle—POWER ON |
| | - - - - - | | | - | mounting hardware: (not included w/switch) |
| -72 | 210-0046-00 | | | 1 | LOCKWASHER, internal, 1/4 ID x 0.400 inch OD |
| | 210-0940-00 | | | 1 | WASHER, flat, 1/4 ID x 3/8 inch OD |
| -73 | 210-0562-00 | | | 1 | NUT, hex., 1/4-40 x 5/16 inch |
| -74 | 136-0223-00 | | | 1 | SOCKET, light |
| | - - - - - | | | - | mounting hardware: (not included w/socket) |
| | 210-0223-00 | | | 1 | LUG, solder, 1/4 ID x 7/16 inch OD, SE |
| -75 | 210-0562-00 | | | 1 | NUT, hex., 1/4-40 x 5/16 inch |

FIG. 1 FRONT (cont)

| Fig. & Index No. | Tektronix Part No. | Serial/Model No. | | Q t y | Description |
|------------------------|-----------------------|------------------|---------|-------------|--|
| | | Eff | Disc | | |
| 1-76 | 131-0352-01 | | | 3 | CONNECTOR, BNC, female, w/mounting hardware |
| -77 | 378-0541-00 | | | 1 | FILTER, lens, green |
| -78 | 378-0541-01 | | | 4 | FILTER, lens, clear |
| -79 | 352-0084-00 | | | 2 | HOLDER, neon, black |
| -80 | 352-0084-01 | | | 3 | HOLDER, neon, white |
| -81 | 200-0609-00 | | | 5 | COVER, neon, holder |
| -82 | 358-0054-00 | | | 1 | BUSHING, banana jack |
| | - - - - - | | | - | mounting hardware: (not included w/bushing) |
| -83 | 210-0223-00 | | | 1 | LUG, solder, 1/4 ID x 7/16 inch OD, SE |
| | 210-0583-00 | B010100 | B091789 | 1 | NUT, hex., 1/4-32 x 5/16 inch |
| | 210-0465-00 | B091790 | | 1 | NUT, hex., 1/4-32 x 3/8 inch |
| -84 | 131-0438-00 | | | 2 | CONNECTOR, 3 contact, female |
| | - - - - - | | | - | mounting hardware for each: (not included w/connector) |
| -85 | 210-0012-00 | | | 1 | LOCKWASHER, internal, 3/8 ID x 1/2 inch OD |
| | 210-0590-00 | | | 1 | NUT, hex., 3/8-32 x 7/16 inch |
| -86 | 358-0216-00 | | | 2 | BUSHING, dove gray |
| -87 | 260-0717-00 | | | 1 | SWITCH, push—RESET |
| | - - - - - | | | - | mounting hardware: (not included w/switch) |
| | 210-0012-00 | | | 1 | LOCKWASHER, internal, 3/8 ID x 1/2 inch OD |
| | 210-0978-00 | | | 1 | WASHER, flat, 3/8 ID x 1/2 inch OD |
| -88 | 210-0590-00 | | | 1 | NUT, hex., 3/8-32 x 7/16 inch |
| -89 | 260-0838-00 | | | 1 | SWITCH, lever—BEAM FINDER |
| | - - - - - | | | - | mounting hardware: (not included w/switch) |
| | 210-1025-00 | | | 1 | WASHER, flat, 0.312 ID x 0.474 inch OD |
| | 210-0580-00 | | | 1 | NUT, hex., 5/16-24 x 3/8 inch |
| -90 | 200-0608-00 | | | 1 | COVER, variable resistor |
| -91 | 378-0573-00 | | | 1 | FILTER, mesh |
| -92 | 214-0654-00 | B010100 | B149999 | 1 | SPRING, filter |
| | 214-0996-00 | B150000 | | 1 | SPRING, filter |
| -93 | 333-0943-01 | | | 1 | PANEL, front |
| -94 | 386-0207-01 | | | 1 | PLATE, sub-panel |
| -95 | 214-0335-00 | | | 1 | BOLT, current loop |
| | - - - - - | | | - | mounting hardware: (not included w/bolt) |
| -96 | 210-0593-00 | | | 2 | NUT, hex., current loop, 3-48 x 1/4 inch |
| -97 | 361-0059-00 | | | 1 | SPACER, current loop |
| -98 | 210-0849-00 | | | 1 | WASHER, fiber, shouldered, #4 |
| -99 | 210-0004-00 | | | 1 | LOCKWASHER, internal, #4 |
| -100 | 210-0994-00 | | | 2 | WASHER, flat, 0.125 ID x 0.250 inch OD |
| -101 | 210-0201-00 | | | 1 | LUG, solder, SE #4 |
| -102 | 210-0442-00 | | | 2 | NUT, hex., 3-48 x 3/16 inch |
| -103 | 358-0054-00 | | | 2 | BUSHING, banana jack |
| -104 | 386-1170-00 | | | 1 | PLATE, mounting |
| -105 | - - - - - | | | 2 | RESISTOR, variable |
| | - - - - - | | | - | mounting hardware for each: (not included w/resistor) |
| -106 | 210-0046-00 | | | 2 | LOCKWASHER, internal, 1/4 ID x 0.400 inch OD |
| | 210-0471-00 | | | 1 | NUT, hex., 1/4-32 x 5/16 x 1 1/32 inch long |

FIG. 1 FRONT (cont)

| Fig. & Index No. | Tektronix Part No. | Serial/Model No. Eff | No. Disc | Q † Y | Description | | | | |
|------------------|--------------------|----------------------|----------|-------------|--|---|---|---|---|
| | | | | | 1 | 2 | 3 | 4 | 5 |
| 1-107 | 129-0070-00 | | | 1 | POST, terminal | | | | |
| | - - - - - | | | | - mounting hardware: (not included w/post) | | | | |
| | 210-0001-00 | | | 1 | LOCKWASHER, internal, #2 | | | | |
| | 210-0405-00 | | | 1 | NUT, hex., 2-56 x 3/16 inch | | | | |
| | 129-0103-00 | B010100 | B249999 | 1 | ASSEMBLY, binding post | | | | |
| | - - - - - | | | | - assembly includes: | | | | |
| -108 | 200-0103-00 | | | 1 | CAP, binding post | | | | |
| -109 | 129-0077-00 | | | 1 | POST, binding | | | | |
| | - - - - - | | | | - mounting hardware: (not included w/assembly) | | | | |
| | 210-0011-00 | | | 1 | LOCKWASHER, internal, 1/4 ID x 15/32 inch OD | | | | |
| -110 | 210-0455-00 | | | 1 | NUT, hex., 1/4-28 x 3/8 inch | | | | |
| | 200-0103-00 | B250000 | | 1 | CAP, binding post | | | | |
| | 129-0076-03 | B250000 | | 1 | POST, binding | | | | |
| | - - - - - | | | | - mounting hardware: (not included w/post) | | | | |
| | 210-0009-00 | | | 1 | LOCKWASHER, external, #10 | | | | |
| | 210-0410-00 | | | 1 | NUT, hex., 10-32 x 5/16 inch | | | | |
| -111 | - - - - - | | | 1 | RESISTOR, variable | | | | |
| | - - - - - | | | | - mounting hardware: (not included w/resistor) | | | | |
| -112 | 358-0075-00 | | | 1 | BUSHING, resistor mounting | | | | |
| -113 | 131-0352-01 | | | 4 | CONNECTOR, BNC, female, w/mounting hardware | | | | |
| | - - - - - | | | | - mounting hardware for each: (not included w/connector) | | | | |
| -114 | 210-0255-00 | | | 1 | LUG, solder, 3/8 inch | | | | |
| -115 | 366-0236-00 | | | 1 | KNOB, charcoal—B TIME/DIV | | | | |
| | - - - - - | | | | - knob includes: | | | | |
| | 213-0020-00 | | | 1 | SCREW, set, 6-32 x 1/8 inch, HSS | | | | |
| -116 | - - - - - | | | 1 | RESISTOR, variable | | | | |
| | - - - - - | | | | - mounting hardware: (not included w/resistor) | | | | |
| -117 | 210-0590-00 | | | 1 | NUT, hex., 3/8-32 x 7/16 inch | | | | |
| -118 | 343-0013-00 | | | 1 | CLAMP, cable, plastic, 3/8 inch diameter | | | | |
| | - - - - - | | | | - mounting hardware: (not included w/clamp) | | | | |
| -119 | 210-0863-00 | | | 1 | WASHER, "D" shape, 0.191 ID x 33/64 W x 33/64 inch long | | | | |
| -120 | 210-0457-00 | | | 1 | NUT, keps, 6-32 x 5/16 inch | | | | |
| -121 | 407-0282-00 | | | 1 | BRACKET, circuit board, rear | | | | |
| | - - - - - | | | | - mounting hardware: (not included w/bracket) | | | | |
| -122 | 211-0033-00 | B010100 | B249999 | 1 | SCREW, sems, 4-40 x 5/16 inch, PHS | | | | |
| | 211-0101-00 | B250000 | | 1 | SCREW, 4-40 x 1/4 inch, 100° csk, FHS | | | | |

FIG. 1 FRONT (cont)

| Fig. & Index No. | Tektronix Part No. | Serial/Model No. | | Q † Y | Description |
|------------------------|-----------------------|------------------|---------|-------------|--|
| | | Eff | Disc | | |
| 1-123 | 407-0281-00 | | | 1 | BRACKET, circuit board, front |
| | - - - - - | | | - | mounting hardware: (not included w/bracket) |
| -124 | 211-0033-00 | B010100 | B249999 | 1 | SCREW, sems, 4-40 x 5/16 inch, PHS |
| | 211-0101-00 | B250000 | | 1 | SCREW, 4-40 x 1/4 inch, 100° csk, FHS |
| -125 | 131-0371-00 | | | 3 | CONNECTOR, single contact |
| -126 | 670-0494-00 | | | 1 | ASSEMBLY, circuit board—CALIBRATOR |
| | - - - - - | | | - | assembly includes: |
| | 388-0786-00 | | | 1 | BOARD, circuit |
| -127 | 214-0506-00 | | | 5 | PIN, connector |
| -128 | 136-0220-00 | | | 3 | SOCKET, transistor, 3 pin |
| | - - - - - | | | - | mounting hardware: (not included w/assembly) |
| -129 | 211-0116-00 | | | 4 | SCREW, sems, 4-40 x 5/16 inch, PHB |
| -130 | 333-0944-00 | B010100 | B249999 | 1 | PANEL, front (calibrator chassis) |
| | 333-0941-01 | B250000 | | 1 | PANEL, front (calibrator chassis) |
| -131 | 441-0688-01 | | | 1 | CHASSIS, calibrator |
| -132 | 211-0598-00 | | | 1 | SCREW, captive, 6-32 x 3/8 inch, Fil HS |
| -133 | 210-0869-00 | | | 1 | WASHER, plastic, 5/32 ID x 3/8 inch OD |
| -134 | 354-0163-00 | | | 1 | RING, retaining |
| -135 | 354-0165-00 | | | 1 | RING, retaining |
| -136 | 210-0805-00 | | | 1 | WASHER, flat, 0.204 ID x 0.438 inch OD |
| -137 | 214-0573-00 | | | 1 | PIN, hinge |

FIG. 2 ATTENUATOR PREAMPLIFIER ASSEMBLY & A and B TIME/DIV and DELAY TIME SWITCH

| Fig. & Index No. | Tektronix Part No. | Serial/Model No. Eff | No. Disc | Q † Y | Description | | | | |
|------------------|--------------------|----------------------|----------|-------------|--|---|---|---|---|
| | | | | | 1 | 2 | 3 | 4 | 5 |
| 2- | 644-0416-00 | | | 1 | ASSEMBLY, attenuator preamplifier | | | | |
| -1 | - - - - - | | | - | assembly includes: | | | | |
| | - - - - - | | | 2 | RESISTOR, variable | | | | |
| | - - - - - | | | - | mounting hardware for each: (not included w/resistor) | | | | |
| -2 | 210-0223-00 | B010100 | B033569 | 1 | LUG, solder, 1/4 ID x 7/16 inch OD, SE | | | | |
| | 210-0905-00 | B033570 | | 1 | WASHER, flat, 0.265 ID x 7/16 inch OD | | | | |
| | 210-0046-00 | B033570 | | 1 | LOCKWASHER, internal, 0.261 ID x 0.400 inch OD | | | | |
| -3 | 358-0075-00 | | | 1 | BUSHING, resistor mounting | | | | |
| -4 | - - - - - | | | 2 | RESISTOR, variable | | | | |
| | - - - - - | | | - | mounting hardware for each: (not included w/resistor) | | | | |
| | 210-0223-00 | XB033570 | | 2 | LUG, solder, 1/4 ID x 7/16 inch OD, SE | | | | |
| | 210-0940-00 | | | 1 | WASHER, flat, 1/4 ID x 3/8 inch OD | | | | |
| -5 | 210-0583-00 | | | 1 | NUT, hex., 1/4-32 x 5/16 inch | | | | |
| -6 | 378-0541-00 | | | 2 | FILTER, lens, clear | | | | |
| -7 | 352-0129-00 | | | 2 | HOLDER, neon, single | | | | |
| | - - - - - | | | - | mounting hardware for each: (not included w/holder) | | | | |
| -8 | 211-0106-00 | | | 1 | SCREW, 4-40 x 5/8 inch, 100° csk, FHS | | | | |
| -9 | 210-0406-00 | | | 2 | NUT, hex., 4-40 x 3/16 inch | | | | |
| -10 | 386-1132-00 | | | 1 | PLATE, component mounting | | | | |
| -11 | 376-0062-00 | | | 1 | COUPLING, slide switch to shaft | | | | |
| -12 | 210-0201-00 | | | 1 | LUG, solder, SE #4 | | | | |
| | - - - - - | | | - | mounting hardware: (not included w/lug) | | | | |
| | 211-0007-00 | | | 1 | SCREW, 4-40 x 3/16 inch, PHS | | | | |
| | 644-0421-00 | | | 1 | ASSEMBLY, front plate & chassis attenuator | | | | |
| | - - - - - | | | - | assembly includes: | | | | |
| -13 | 337-0953-00 | | | 2 | SHIELD, electrical | | | | |
| -14 | - - - - - | | | 2 | SWITCH, unwired—VOLTS/DIV (CH 1 & CH 2) | | | | |
| -15 | 131-0352-00 | | | 2 | CONNECTOR, BNC, female, w/hardware | | | | |
| | - - - - - | | | - | mounting hardware for each: (not included w/connector) | | | | |
| | 166-0402-00 | | | 1 | SPACER, BNC connector | | | | |
| -16 | 131-0157-00 | | | 2 | CONNECTOR, terminal, stand off | | | | |
| -17 | 337-0882-00 | | | 2 | SHIELD, electrical | | | | |
| -18 | 214-0599-00 | | | 6 | SPRING, switch shaft ground | | | | |
| | 610-0485-00 | | | 1 | ASSEMBLY, attenuator (CH 1) | | | | |
| | - - - - - | | | - | assembly includes: | | | | |
| -19 | 441-0695-00 | | | 1 | CHASSIS, attenuator | | | | |
| -20 | - - - - - | | | 2 | CAPACITOR | | | | |
| | - - - - - | | | - | mounting hardware for each: (not included w/capacitor) | | | | |
| | 214-0456-00 | | | 1 | FASTENER, plastic | | | | |
| -21 | 131-0433-00 | | | 1 | CONNECTOR, terminal | | | | |
| | - - - - - | | | - | mounting hardware: (not included w/connector) | | | | |
| | 358-0241-00 | | | 1 | BUSHING, plastic | | | | |
| -22 | 260-0621-00 | | | 1 | SWITCH, lever—AC GND DC | | | | |
| | - - - - - | | | - | mounting hardware: (not included w/switch) | | | | |
| -23 | 211-0101-00 | | | 2 | SCREW, 4-40 x 1/4 inch, 100° csk, FHS | | | | |
| | 210-0004-00 | | | 2 | LOCKWASHER, internal, #4 | | | | |
| -24 | 210-0406-00 | | | 2 | NUT, hex., 4-40 x 3/16 inch | | | | |

FIG. 2 ATTENUATOR PREAMPLIFIER ASSEMBLY & A and B TIME/DIV and DELAY TIME SWITCH (cont)

| Fig. & Index No. | Tektronix Part No. | Serial/Model No. | | Q † Y | Description |
|------------------------|-----------------------|------------------|---------|-------------|--|
| | | Eff | Disc | | |
| 2- | 610-0485-00 | | | 1 | ASSEMBLY, attenuator (CH 2) |
| -25 | 441-0695-00 | | | - | attenuator includes: |
| -26 | - - - - - | | | 1 | CHASSIS, attenuator |
| -27 | 214-0456-00 | | | 2 | CAPACITOR |
| | - - - - - | | | - | mounting hardware for each: (not included w/capacitor) |
| -28 | 131-0433-00 | | | 1 | FASTENER, plastic |
| | - - - - - | | | - | CONNECTOR, terminal |
| | 358-0241-00 | | | - | mounting hardware: (not included w/connector) |
| | - - - - - | | | 1 | BUSHING, plastic |
| -29 | 260-0621-00 | | | 1 | SWITCH, lever—AC GND DC |
| | - - - - - | | | - | mounting hardware: (not included w/switch) |
| -30 | 211-0101-00 | | | 2 | SCREW, 4-40 x 1/4 inch, 100° csk, FHS |
| | 210-0004-00 | | | 2 | LOCKWASHER, internal, #4 |
| -31 | 210-0406-00 | | | 2 | NUT, hex., 4-40 x 3/16 inch |
| -32 | 179-1138-00 | | | 1 | CABLE HARNESS, vertical preamplifier |
| | - - - - - | | | - | cable harness includes: |
| -33 | 131-0371-00 | | | 25 | CONNECTOR, single contact |
| -34 | 262-0797-00 | | | 1 | SWITCH, wired—MODE |
| | - - - - - | | | - | switch includes: |
| | 260-0695-00 | B010100 | B010119 | 1 | SWITCH, unwired |
| | 260-0695-01 | B010120 | | 1 | SWITCH, unwired |
| | 131-0371-00 | | | 7 | CONNECTOR, single contact (not shown) |
| -35 | 407-0157-00 | | | 1 | BRACKET, switch |
| -36 | 210-0012-00 | | | 2 | LOCKWASHER, internal, 3/8 ID x 1/2 inch OD |
| -37 | 210-0413-00 | | | 1 | NUT, hex., 3/8-32 x 1/2 inch |
| -38 | 384-0655-00 | | | 2 | SHAFT, extension |
| -39 | - - - - - | | | 2 | RESISTOR, variable |
| | - - - - - | | | - | mounting hardware for each: (not included w/resistor) |
| -40 | 220-0464-00 | | | 2 | NUT, round, 2-56 x 0.438 inch long |
| -41 | 384-0272-00 | | | 2 | ROD, extension, w/plastic extension |
| -42 | - - - - - | | | 2 | RESISTOR, variable |
| | - - - - - | | | - | mounting hardware for each: (not included w/resistor) |
| -43 | 210-0046-00 | | | 1 | LOCKWASHER, internal, 1/4 ID x 0.400 inch OD |
| -44 | 210-0583-00 | | | 1 | NUT, hex., 1/4-32 x 5/16 inch |
| -45 | 376-0051-00 | | | 2 | ASSEMBLY, coupling |
| | - - - - - | | | - | each assembly includes |
| | 354-0251-00 | | | 2 | RING, coupling |
| | 376-0049-00 | | | 1 | COUPLING, plastic |
| | 213-0022-00 | | | 4 | SCREW, set, 4-40 x 3/16 inch, HSS |

FIG. 2 ATTENUATOR PREAMPLIFIER ASSEMBLY & A and B TIME/DIV and DELAY TIME SWITCH (cont)

| Fig. & Index No. | Tektronix Part No. | Serial/Model No. Eff | No. Disc | Q † Y | Description | | | | | |
|------------------|--------------------|----------------------|----------|-------------|-------------|---|---|---|---|---|
| | | | | | 1 | 2 | 3 | 4 | 5 | |
| 2-46 | 384-0650-00 | | | 1 | | | | | | ROD, extension, w/knob—INVERT |
| -47 | 670-0491-00 | | | 1 | | | | | | ASSEMBLY, circuit board—VERTICAL PREAMPLIFIER |
| | - - - - - | | | - | | | | | | assembly includes: |
| | 388-0788-00 | | | 1 | | | | | | BOARD, circuit |
| -48 | 131-0183-00 | | | 2 | | | | | | CONNECTOR, terminal, feed thru |
| | - - - - - | | | - | | | | | | mounting hardware for each: (not included w/connector) |
| | 358-0136-00 | | | 1 | | | | | | BUSHING, plastic (not shown) |
| -49 | 136-0224-00 | | | 2 | | | | | | SOCKET, unvisor |
| -50 | 136-0220-00 | | | 24 | | | | | | SOCKET, transistor, 3 pin |
| -51 | 131-0498-00 | | | 2 | | | | | | LINK, terminal connector |
| -52 | 136-0234-00 | | | 4 | | | | | | RECEPTACLE, electrical |
| -53 | 214-0506-00 | | | 45 | | | | | | PIN, connector |
| -54 | 260-0723-00 | | | 1 | | | | | | SWITCH, slide—INVERT |
| | 343-0159-00 | XB120000 | | 1 | | | | | | RETAINER, slide switch |
| -55 | 200-0642-00 | | | 1 | | | | | | CAP |
| -56 | - - - - - | | | 4 | | | | | | CAPACITOR, w/mounting hardware |
| | - - - - - | | | - | | | | | | mounting hardware: (not included w/assembly) |
| -57 | 211-0116-00 | | | 5 | | | | | | SCREW, sems, 4-40 x 5/16 inch, PHS |
| | - - - - - | | | - | | | | | | mounting hardware: (not included w/attenuator preamplifier) |
| -58 | 211-0121-00 | | | 1 | | | | | | SCREW, sems, 4-40 x 0.438 inch, PHB |
| -59 | 211-0116-00 | | | 2 | | | | | | SCREW, sems, 4-40 x 5/16 inch, PHS |
| | 210-0201-00 | X260000 | | 1 | | | | | | LUG, solder, SE #4 |
| -60 | 210-1001-00 | | | 3 | | | | | | WASHER, flat, 0.119 ID x 3/8 inch OD |
| -61 | 210-0457-00 | | | 4 | | | | | | NUT, keps, 6-32 x 5/16 inch |
| -62 | 337-0982-00 | B010100 | B099999 | 1 | | | | | | SHIELD, attenuator |
| | 337-0982-03 | B0100000 | | 1 | | | | | | SHIELD, attenuator |
| | - - - - - | | | - | | | | | | mounting hardware: (not included w/shield) |
| | 211-0007-00 | | | 4 | | | | | | SCREW, 4-40 x 3/16 inch PHS |
| -63 | 262-0801-00 | | | 1 | | | | | | SWITCH, wired—A and B TIME/DIV and DELAY TIME |
| | - - - - - | | | - | | | | | | switch includes: |
| | 260-0823-00 | | | 1 | | | | | | SWITCH, unwired |
| | 131-0371-00 | | | 10 | | | | | | CONNECTOR, single contact (not shown) |
| -64 | 384-0262-00 | | | 1 | | | | | | ROD, extension |
| -65 | - - - - - | | | 1 | | | | | | CAPACITOR |
| | - - - - - | | | - | | | | | | mounting hardware: (not included w/capacitor) |
| -66 | 210-0457-00 | | | 2 | | | | | | NUT, keps, 6-32 x 5/16 inch |
| -67 | - - - - - | | | 2 | | | | | | CAPACITOR |
| | - - - - - | | | - | | | | | | mounting hardware for each: (not included w/capacitor) |
| -68 | 210-0018-00 | | | 1 | | | | | | LOCKWASHER, internal, 5/16 ID x 19/32 inch OD |
| -69 | 210-0524-00 | | | 1 | | | | | | NUT, hex., 5/16-24 x 1/2 inch |
| -70 | 348-0055-00 | | | 1 | | | | | | GROMMET, plastic, 1/4 inch diameter |
| -71 | 407-0290-00 | | | 1 | | | | | | BRACKET, electrical |
| | - - - - - | | | - | | | | | | mounting hardware: (not included w/bracket) |
| -72 | 210-0202-00 | | | 1 | | | | | | LUG, solder, SE #6 |
| -73 | 210-0006-00 | | | 1 | | | | | | LOCKWASHER, internal, #6 |
| -74 | 210-0449-00 | | | 2 | | | | | | NUT, hex., 5-40 x 1/4 inch |

FIG. 2 ATTENUATOR PREAMPLIFIER ASSEMBLY & A and B TIME/DIV and DELAY TIME SWITCH (cont)

| Fig. & Index No. | Tektronix Part No. | Serial/Model Eff No. Disc | Q † y | 1 2 3 4 5 | | | | | Description |
|------------------------|-----------------------|---------------------------------|-------------|-----------|---|---|---|---|--|
| | | | | 1 | 2 | 3 | 4 | 5 | |
| 2-75 | 131-0181-00 | | 2 | | | | | | CONNECTOR, terminal, standoff |
| | - - - - - | | - | | | | | | mounting hardware for each: (not included w/connector) |
| | 358-0136-00 | | 1 | | | | | | BUSHING, plastic |
| -76 | 376-0014-00 | | 1 | | | | | | COUPLING |
| -77 | - - - - - | | 1 | | | | | | RESISTOR, variable |
| | - - - - - | | - | | | | | | mounting hardware: (not included w/resistor) |
| -78 | 210-0413-00 | | 2 | | | | | | NUT, hex., 3/8-32 x 1/2 inch |
| -79 | 210-0012-00 | | 1 | | | | | | LOCKWASHER, internal, 3/8 ID x 1/2 inch OD |
| -80 | 179-1141-00 | | 1 | | | | | | CABLE HARNESS |
| | - - - - - | | - | | | | | | mounting hardware: (not included w/switch) |
| -81 | 211-0507-00 | | 2 | | | | | | SCREW, 6-32 x 5/16 inch, PHS |
| | 210-0013-00 | | 1 | | | | | | LOCKWASHER, internal, 3/8 ID x 11/16 inch OD (not shown) |
| | 210-0579-00 | | 1 | | | | | | NUT, hex., 5/8-24 x 3/4 inch (not shown) |

FIG. 3 CRT & SHIELD ASSEMBLY

| Fig. & Index No. | Tektronix Part No. | Serial/Model No. Eff | No. Disc | Q | | | | | Description |
|------------------|--------------------|----------------------|----------|---|---|---|---|---|---|
| | | | | f | 1 | 2 | 3 | 4 | |
| 3-1 | 136-0205-00 | | | 2 | | | | | SOCKET, graticule lamp |
| | - - - - - | | | - | | | | | mounting hardware for each: (not included w/socket) |
| -2 | 210-0586-00 | | | 1 | | | | | NUT, keps, 4-40 x 1/4 inch |
| | - - - - - | | | 1 | | | | | ASSEMBLY, CRT & shield |
| | - - - - - | | | - | | | | | assembly includes: |
| -3 | 337-0872-01 | | | 1 | | | | | SHIELD, CRT |
| -4 | 337-0946-01 | | | 1 | | | | | SHIELD, CRT, (outer) |
| -5 | 348-0070-01 | | | 4 | | | | | CUSHION, CRT |
| -6 | 331-0141-00 | | | 1 | | | | | MASK, graticule |
| -7 | 354-0258-00 | | | 1 | | | | | RING, reflector light plate |
| -8 | - - - - - | | | 1 | | | | | COIL |
| | - - - - - | | | - | | | | | mounting hardware: (not included w/coil) |
| -9 | 211-0590-00 | | | 2 | | | | | SCREW, 6-32 x 1/4 inch, PHS |
| -10 | 210-0202-00 | | | 1 | | | | | LUG, solder, SE #6 |
| | - - - - - | | | - | | | | | mounting hardware: (not included w/lug) |
| -11 | 211-0590-00 | | | 1 | | | | | SCREW, 6-32 x 1/4 inch, PHS |
| -12 | 210-0407-00 | | | 1 | | | | | NUT, hex., 6-32 x 1/4 inch |
| -13 | 343-0110-00 | | | 1 | | | | | CLAMP, coil form |
| | - - - - - | | | - | | | | | mounting hardware: (not included w/clamp) |
| -14 | 211-0590-00 | | | 2 | | | | | SCREW, 6-32 x 1/4 inch, PHS |
| -15 | 210-0006-00 | | | 2 | | | | | LOCKWASHER, internal, #6 |
| -16 | 210-0407-00 | | | 2 | | | | | NUT, hex., 6-32 x 1/4 inch |
| -17 | 358-0281-00 | | | 1 | | | | | BUSHING, CRT cable |
| -18 | 343-0124-00 | | | 1 | | | | | CLAMP, retainer |
| | - - - - - | | | - | | | | | mounting hardware: (not included w/clamp) |
| -19 | 211-0599-00 | | | 2 | | | | | SCREW, 6-32 x 3/4 inch, Fil HS |
| -20 | 220-0444-00 | | | 2 | | | | | NUT, square, 6-32 x 1/4 inch |
| -21 | 352-0091-01 | | | 2 | | | | | HOLDER, CRT retainer |
| | - - - - - | | | - | | | | | mounting hardware for each: (not included w/holder) |
| -22 | 211-0590-00 | | | 2 | | | | | SCREW, 6-32 x 1/4 inch, PHS |
| -23 | 343-0123-01 | | | 2 | | | | | CLAMP, CRT retainer |
| -24 | 220-0444-00 | | | 1 | | | | | NUT, square, 6-32 x 1/4 inch |
| -25 | 211-0600-00 | | | 1 | | | | | SCREW, 6-32 x 2 inches, Fil HS |
| | - - - - - | | | - | | | | | mounting hardware: (not included w/assembly) |
| -26 | 343-0122-01 | | | 2 | | | | | CLAMP, CRT shield |
| | 213-0049-00 | | | 1 | | | | | SCREW, 6-32 x 5/16 inch, HHS |
| -27 | 210-0949-00 | | | 2 | | | | | WASHER, flat, 9/64 ID x 1/2 inch OD |
| -28 | 211-0510-00 | | | 2 | | | | | SCREW, 6-32 x 3/8 inch, PHS |

FIG. 3 CRT & SHIELD ASSEMBLY (cont)

| Fig. & Index No. | Tektronix Part No. | Serial/Model No. | | Q † Y | Description |
|------------------------|-----------------------|------------------|---------|-------------|---------------------------------------|
| | | Eff | Disc | | |
| 3-29 | 131-0472-01 | | | 6 | CONNECTOR, pin, female |
| -30 | 179-1146-00 | | | 1 | CABLE HARNESS, graticule light |
| -31 | 179-1137-00 | | | 1 | CABLE HARNESS, anode |
| | - - - - - | | | - | cable harness includes: |
| | 131-0371-00 | | | 3 | CONNECTOR, single contact (not shown) |
| -32 | 131-0477-00 | | | 1 | CONNECTOR, anode |
| | - - - - - | | | - | connector includes: |
| | 131-0026-00 | | | 1 | CONNECTOR, cable |
| | 175-0012-00 | | | FT | CABLE, high-voltage |
| | 200-0544-00 | | | 1 | COVER, anode connector |
| -33 | 179-1145-00 | B010100 | B122359 | 1 | CABLE HARNESS, CRT socket |
| | 136-0247-00 | B122360 | | 1 | ASSEMBLY, CRT socket |
| | - - - - - | | | - | assembly includes: |
| -34 | 136-0202-01 | | | 1 | SOCKET, CRT, w/pins |
| -35 | 210-0405-00 | | | 2 | NUT, hex., 2-56 x 3/16 inch |
| -36 | 211-0034-00 | | | 2 | SCREW, 2-56 x 1/2 inch, PHS |
| -37 | 200-0616-00 | | | 1 | COVER, CRT socket |
| -38 | 337-0964-00 | | | 1 | SHIELD, light |

FIG. 4 A SWEEP, B SWEEP & HIGH-VOLTAGE SUPPLY

| Fig. & Index No. | Tektronix Part No. | Serial/Model No. Eff | No. Disc | Q † y | | | | | | Description |
|------------------|--------------------|----------------------|----------|-------------|---|---|---|---|---|--|
| | | | | | 1 | 2 | 3 | 4 | 5 | |
| 4-1 | 670-0493-00 | B010100 | B069999 | 1 | | | | | | ASSEMBLY, circuit board—B SWEEP |
| | 670-0493-01 | B070000 | B189999 | 1 | | | | | | ASSEMBLY, circuit board—B SWEEP |
| | 670-0493-01 | B070000 | B199999 | 1 | | | | | | ASSEMBLY, circuit board—B SWEEP |
| | 670-0493-02 | B200000 | B219999 | 1 | | | | | | ASSEMBLY, circuit board—B SWEEP |
| | 670-0492-03 | B220000 | | 1 | | | | | | ASSEMBLY, circuit board—B SWEEP |
| | 388-0790-00 | | | - | | | | | | assembly includes: |
| | | | | 1 | | | | | | BOARD, circuit |
| -2 | 214-0506-00 | | | 58 | | | | | | PIN, connector |
| -3 | 337-0764-00 | | | 1 | | | | | | SHIELD, electrical |
| -4 | 337-0896-00 | | | 1 | | | | | | SHIELD, electrical |
| -5 | 214-0579-00 | | | 9 | | | | | | PIN, test point |
| -6 | 344-0119-00 | | | 6 | | | | | | CLIP, electrical |
| -7 | 214-0565-00 | | | 1 | | | | | | FASTENER, pin press |
| -8 | 136-0220-00 | | | 25 | | | | | | SOCKET, transistor, 3 pin |
| -9 | 136-0235-00 | | | 2 | | | | | | SOCKET, transistor, 6 pin |
| -10 | 136-0125-00 | | | 2 | | | | | | SOCKET, nuvistor |
| -11 | 343-0043-00 | | | 1 | | | | | | CLAMP, wire, neon bulb |
| | | | | - | | | | | | mounting hardware: (not included w/assembly) |
| -12 | 211-0116-00 | | | 6 | | | | | | SCREW, sems, 4-40 x 5/16 inch, PHB |
| -13 | 200-0687-00 | B010100 | B109999 | 1 | | | | | | COVER, transistor |
| | 200-0687-01 | B110000 | | 1 | | | | | | COVER, transistor |
| -14 | 343-0088-00 | | | 3 | | | | | | CLAMP, cable, small |
| -15 | 343-0089-00 | | | 2 | | | | | | CLAMP, cable, large |
| -16 | 179-1134-00 | | | 1 | | | | | | CABLE HARNESS, B Sweep |
| | | | | - | | | | | | cable harness includes: |
| | 131-0371-00 | | | 17 | | | | | | CONNECTOR, single contact |
| -17 | 179-1133-00 | | | 1 | | | | | | CABLE HARNESS, A Sweep |
| | | | | - | | | | | | cable harness includes: |
| | 131-0371-00 | | | 54 | | | | | | CONNECTOR, single contact |
| -18 | 670-0492-00 | B010100 | B069999 | 1 | | | | | | ASSEMBLY, circuit board—A SWEEP |
| | 670-0492-01 | B070000 | B189999 | 1 | | | | | | ASSEMBLY, circuit board—A SWEEP |
| | 670-0492-02 | B190000 | B219999 | 1 | | | | | | ASSEMBLY, circuit board—A SWEEP |
| | 670-0492-03 | B220000 | | 1 | | | | | | ASSEMBLY, circuit board—A SWEEP |
| | 388-0791-00 | B010100 | B149999 | 1 | | | | | | assembly includes: |
| | | | | 1 | | | | | | BOARD, circuit |
| | 388-0791-01 | B150000 | B189999 | 1 | | | | | | BOARD, circuit |
| | 388-0791-02 | B190000 | | 1 | | | | | | BOARD, circuit |
| -19 | 214-0506-00 | | | 56 | | | | | | PIN, connector |
| -20 | 337-0894-00 | | | 1 | | | | | | SHIELD, electrical |
| -21 | 337-0763-00 | | | 1 | | | | | | SHIELD, electrical |
| -22 | 214-0579-00 | | | 7 | | | | | | PIN, test point |
| -23 | 214-0565-00 | | | 2 | | | | | | FASTENER, pin press |
| -24 | 136-0220-00 | B010100 | B219999 | 24 | | | | | | SOCKET, transistor, 3 pin |
| | 136-0220-00 | B220000 | | 19 | | | | | | SOCKET, transistor, 3 pin |
| | 136-0252-01 | B220000 | | 5 | | | | | | SOCKET, transistor, 3 pin |
| -25 | 136-0235-00 | | | 1 | | | | | | SOCKET, transistor, 6 pin |
| -26 | 136-0125-00 | | | 2 | | | | | | SOCKET, nuvistor |
| -27 | 136-0183-00 | | | 1 | | | | | | SOCKET, transistor, 3 pin |
| -28 | 343-0043-00 | | | 1 | | | | | | CLAMP, wire, neon bulb |
| | | | | - | | | | | | mounting hardware: (not included w/assembly) |
| -29 | 211-0116-00 | B010100 | B119999 | 6 | | | | | | SCREW, sems, 4-40 x 5/16 inch, PHB |
| | 211-0116-00 | B120000 | | 4 | | | | | | SCREW, sems, 4-40 x 5/16 inch, PHB |
| | 211-0040-00 | B120000 | | 2 | | | | | | SCREW, 4-40 x 1/4 inch, BH plastic |
| | 210-1065-00 | B120000 | | 2 | | | | | | WASHER, plastic, 0.125 ID x 0.312 inch OD |

FIG. 4 A SWEEP, B SWEEP & HIGH-VOLTAGE SUPPLY (cont)

| Fig. & Index No. | Tektronix Part No. | Serial/Model No. | | Q † Y | Description |
|------------------|--------------------|------------------|---------|-------------|---|
| | | Eff | Disc | | |
| 4-30 | 200-0687-00 | B010100 | B109999 | 1 | COVER, transistor |
| | 200-0687-01 | B110000 | | 1 | COVER, transistor |
| -31 | 407-0150-00 | | | 1 | BRACKET, outer support |
| | - - - - - | | | - | mounting hardware: (not included w/bracket) |
| | 211-0504-00 | | | 2 | SCREW, 6-32 x 1/4 inch, PHS (not shown) |
| -32 | 386-1129-00 | | | 1 | SUPPORT, chassis |
| | - - - - - | | | - | mounting hardware: (not included w/support) |
| | 211-0504-00 | | | 1 | SCREW, 6-32 x 1/4 inch, PHS |
| | 212-0001-00 | | | 1 | SCREW, 8-32 x 1/4 inch, PHS (not shown) |
| | 210-0457-00 | | | 1 | NUT, keps, 6-32 x 5/16 inch (not shown) |
| -33 | 214-0982-00 | | | 2 | SPRING, grounding |
| | - - - - - | | | - | mounting hardware for each: (not included w/spring) |
| | 211-0007-00 | | | 1 | SCREW, 4-40 x 3/16 inch, PHS |
| -34 | 210-0201-00 | | | 1 | LUG, solder, SE #4 |
| | - - - - - | | | - | mounting hardware: (not included w/lug) |
| | 210-0406-00 | | | 1 | NUT, hex., 4-40 x 3/16 inch |
| -35 | 131-0157-00 | | | 2 | CONNECTOR, terminal, standoff |
| -36 | 214-0317-00 | | | 2 | HEAT SINK |
| -37 | 352-0062-00 | | | 2 | HOLDER, heat sink |
| | - - - - - | | | - | mounting hardware for each: (not included w/holder) |
| -38 | 211-0012-00 | | | 2 | SCREW, 4-40 x 3/8 inch, PHS |
| | 210-0004-00 | | | 2 | LOCKWASHER, internal, #4 |
| -39 | 211-0033-00 | | | 2 | SCREW, sems, 4-40 x 5/16 inch, PHS |
| | 210-0406-00 | | | 4 | NUT, hex., 4-40 x 3/16 inch |
| -40 | 343-0097-00 | | | 2 | CLAMP, heat sink |
| -41 | 210-0627-00 | | | 2 | RIVET, heat sink |
| -42 | 210-0599-00 | | | 4 | NUT, sleeve |
| | 214-0368-00 | | | 2 | SPRING, heat sink |
| | 210-0004-00 | | | 4 | LOCKWASHER, internal, #4 |
| -43 | 200-0256-00 | | | 2 | COVER, capacitor, plastic, 1 ID x 2 1/32 inches long |
| -44 | 200-0538-00 | | | 2 | COVER, capacitor, plastic, 1.365 ID x 1.644 inches long |
| -45 | - - - - - | | | 2 | CAPACITOR |
| | - - - - - | | | - | mounting hardware for each: (not included w/capacitor) |
| -46 | 432-0047-00 | | | 1 | BASE, mounting, small |
| -47 | 386-0252-00 | | | 1 | PLATE, fiber, small |
| | 211-0588-00 | | | 2 | SCREW, 6-32 x 3/4 inch, HHS |
| | 210-0457-00 | | | 2 | NUT, keps, 6-32 x 5/16 inch |
| -48 | - - - - - | | | 2 | CAPACITOR |
| | - - - - - | | | - | mounting hardware for each: (not included w/capacitor) |
| -49 | 432-0048-00 | | | 1 | BASE, mounting, large |
| -50 | 386-0254-00 | | | 1 | PLATE, fiber, large |
| -51 | 211-0588-00 | | | 2 | SCREW, 6-32 x 3/4 inch, HHS |
| | 210-0457-00 | | | 2 | NUT, keps, 6-32 x 5/16 inch |
| -52 | 179-1136-00 | | | 1 | CABLE HARNESS, capacitor |
| | - - - - - | | | - | cable harness includes: |
| | 131-0371-00 | | | 2 | CONNECTOR, single contact |

Mechanical Parts List—Type 454/R454

FIG. 4 A SWEEP, B SWEEP & HIGH-VOLTAGE SUPPLY (cont)

| Fig. & Index No. | Tektronix Part No. | Serial/Model Eff | No. Disc | Q † Y | Description | | | | | |
|------------------------|---|---------------------|-------------|-------------|--|---|---|---|---|--|
| | | | | | 1 | 2 | 3 | 4 | 5 | |
| 4-53 | 344-0140-00 - - - - - 213-0055-00 | | | 1 | CLIP, plastic | | | | | |
| | | | | - | mounting hardware: (not included w/clip) | | | | | |
| | | | | 1 | SCREW, thread forming, 2-32 x 3/16 inch, PHS | | | | | |
| -54 | 407-0300-00 - - - - - 210-0407-00 | | | 1 | BRACKET, capacitor mounting | | | | | |
| | | | | - | mounting hardware: (not included w/bracket) | | | | | |
| | | | | 6 | SCREW, 6-32 x 1/4 inch, PHS (not shown) | | | | | |
| -55 | 337-0875-00 - - - - - 211-0503-00 | | | 1 | SHIELD, high-voltage | | | | | |
| | | | | - | mounting hardware: (not included w/shield) | | | | | |
| | | | | 3 | SCREW, 6-32 x 3/16 inch, PHS (not shown) | | | | | |
| -56 | 200-0708-00 - - - - - | | | 1 | COVER, high-voltage | | | | | |
| | | | | - | mounting hardware: (not included w/cover) | | | | | |
| -57 | 211-0552-00 | | | 2 | SCREW, 6-32 x 2 inches, PHS | | | | | |
| | 621-0429-00 - - - - - | | | 1 | ASSEMBLY, high-voltage | | | | | |
| | | | | - | assembly includes: | | | | | |
| -58 | - - - - - | | | 1 | TRANSFORMER | | | | | |
| | | | | - | mounting hardware: (not included w/transformer) | | | | | |
| -59 | 211-0552-00 | | | 2 | SCREW, 6-32 x 2 inches, PHS | | | | | |
| | 210-0869-00 | | | 2 | WASHER, plastic, 5/32 ID x 3/8 inch OD | | | | | |
| -60 | 358-0231-00 | | | 4 | BUSHING, rubber | | | | | |
| -61 | 210-0966-00 | | | 3 | WASHER, rubber, 5/16 ID x 7/8 inch OD | | | | | |
| -62 | 346-0032-00 | B010100 | B229999X | 1 | STRAP, mouse tail, rubber | | | | | |
| -63 | - - - - - | | | 1 | RESISTOR, variable | | | | | |
| | | | | - | mounting hardware: (not included w/resistor) | | | | | |
| | 210-0046-00 | | | 1 | LOCKWASHER, internal, 1/4 ID x 0.400 inch OD | | | | | |
| -64 | 210-0583-00 | | | 1 | NUT, hex., 1/4-32 x 5/16 inch | | | | | |
| -65 | 441-0693-00 - - - - - | | | 1 | CHASSIS, high-voltage, plastic | | | | | |
| | | | | - | chassis includes: | | | | | |
| -66 | 124-0163-00 | | | 6 | STRIP, ceramic, 7/16 inch h, w/2 notches | | | | | |
| -67 | 124-0164-00 | | | 4 | STRIP, ceramic, 7/16 inch h, w/4 notches | | | | | |
| -68 | 131-0227-00 - - - - - 358-0176-00 | | | 2 | CONNECTOR, terminal, stand off | | | | | |
| | | | | - | mounting hardware for each: (not included w/connector) | | | | | |
| | | | | 1 | BUSHING, plastic (not shown) | | | | | |
| -69 | 131-0359-00 - - - - - 358-0176-00 | | | 1 | CONNECTOR, terminal, feed thru | | | | | |
| | | | | - | mounting hardware: (not included w/connector) | | | | | |
| | | | | 1 | BUSHING, plastic, (not shown) | | | | | |
| | | | | - | mounting hardware: (not included w/chassis) | | | | | |
| -70 | 211-0558-00 | | | 1 | SCREW, 6-32 x 1/4 inch, BH Plastic | | | | | |
| -71 | - - - - - | | | 1 | CAPACITOR | | | | | |
| | | | | - | mounting hardware: (not included w/capacitor) | | | | | |
| | 210-0203-00 | | | 1 | LUG, solder, SE #6 long | | | | | |
| -72 | 211-0503-00 | | | 1 | SCREW, 6-32 x 3/16 inch, PHS | | | | | |
| -73 | 210-0202-00 - - - - - 211-0503-00 | | | 1 | LUG, solder, SE #6 | | | | | |
| | | | | - | mounting hardware: (not included w/lug) | | | | | |
| | | | | 1 | SCREW, 6-32 x 3/16 inch, PHS | | | | | |

FIG. 4 A SWEEP, B SWEEP & HIGH-VOLTAGE SUPPLY (cont)

| Fig. & Index No. | Tektronix Part No. | Serial/Model No. | | Q f y | 1 | 2 | 3 | 4 | 5 | Description |
|------------------------|-----------------------|------------------|------|-------------|---|---|---|---|---|--|
| | | Eff | Disc | | | | | | | |
| 4-74 | 392-0169-00 | | | 1 | | | | | | BOARD, high-voltage, plastic |
| | - - - - - | | | - | | | | | | board includes: |
| -75 | 124-0176-00 | | | 2 | | | | | | STRIP, ceramic, 7/16 inch h, w/4 notches |
| -76 | 124-0175-00 | | | 4 | | | | | | STRIP, ceramic, 13/32 inch h, w/2 notches |
| | - - - - - | | | - | | | | | | mounting hardware: (not included w/board) |
| -77 | 211-0036-00 | | | 1 | | | | | | SCREW, 4-40 x 1/2 inch, BH Plastic |
| -78 | 179-1142-00 | | | 1 | | | | | | CABLE HARNESS, high-voltage, #1 |
| -79 | 179-1143-00 | | | 1 | | | | | | CABLE HARNESS, high-voltage, #2 |
| -80 | 380-0108-00 | | | 1 | | | | | | HOUSING, high-voltage, plastic |
| -81 | 381-0243-00 | | | 1 | | | | | | BAR, heat sink |
| -82 | 166-0368-00 | | | 1 | | | | | | SLEEVE, anode |
| -83 | 124-0148-00 | | | 2 | | | | | | STRIP, ceramic, 7/16 inch h, w/9 notches |
| | - - - - - | | | - | | | | | | each strip includes: |
| | 355-0046-00 | | | 2 | | | | | | STUD, plastic |
| | - - - - - | | | - | | | | | | mounting hardware for each: (not included w/strip) |
| | 361-0007-00 | | | 2 | | | | | | SPACER, plastic, 0.156 inch long |
| -84 | 124-0147-00 | | | 4 | | | | | | STRIP, ceramic, 7/16 inch h, w/13 notches |
| | - - - - - | | | - | | | | | | each strip includes: |
| | 355-0046-00 | | | 2 | | | | | | STUD, plastic |
| | - - - - - | | | - | | | | | | mounting hardware for each: (not included w/strip) |
| | 361-0007-00 | | | 2 | | | | | | SPACER, plastic, 0.156 inch long |

FIG. 5 REAR CHASSIS

| Fig. & Index No. | Tektronix Part No. | Serial/Model No. Eff | No. Disc | Q † Y | Description | | | | | |
|------------------------|-----------------------|-------------------------|-------------|-------------|--|---|---|---|---|---|
| | | | | | | 1 | 2 | 3 | 4 | 5 |
| 5-1 | 670-0495-00 | B010100 | B169999 | 1 | ASSEMBLY, circuit board—VERTICAL OUTPUT | | | | | |
| | 670-0495-01 | B170000 | | 1 | ASSEMBLY, circuit board—VERTICAL OUTPUT | | | | | |
| | - - - - - | | | - | assembly includes: | | | | | |
| | 388-0792-00 | | | 1 | BOARD, circuit | | | | | |
| -2 | 214-0506-00 | | | 11 | PIN, connector | | | | | |
| -3 | 136-0252-00 | B010100 | B169999 | 41 | SOCKET, pin connector | | | | | |
| | 136-0252-01 | B170000 | | 41 | SOCKET, pin connector | | | | | |
| | - - - - - | | | - | mounting hardware: (not included w/assembly) | | | | | |
| -4 | 211-0116-00 | | | 6 | SCREW, sems, 4-40 x 5/16 inch, PHB | | | | | |
| -5 | 179-1144-00 | | | 1 | CABLE HARNESS, vertical output | | | | | |
| | - - - - - | | | - | cable harness includes: | | | | | |
| | 131-0371-00 | | | 5 | CONNECTOR, single contact | | | | | |
| -6 | 407-0279-00 | | | 1 | BRACKET, transistor | | | | | |
| | - - - - - | | | - | mounting hardware: (not included w/bracket) | | | | | |
| -7 | 211-0097-00 | | | 2 | SCREW, 4-40 x 5/16 inch, PHS | | | | | |
| | 210-0586-00 | | | 4 | NUT, keps, 4-40 x 1/4 inch (not shown) | | | | | |
| -8 | 210-0201-00 | | | 2 | LUG, solder, SE #4 | | | | | |
| | - - - - - | | | - | mounting hardware for each: (not included w/lug) | | | | | |
| | 213-0044-00 | | | 1 | SCREW, thread forming, 5-32 x 3/16 inch, PHS | | | | | |
| -9 | 210-0201-00 | | | 3 | LUG, solder, SE #4 | | | | | |
| | - - - - - | | | - | mounting hardware for each: (not included w/lug) | | | | | |
| | 210-0406-00 | | | 1 | NUT, hex., 4-40 x 3/16 inch | | | | | |
| -10 | 210-0202-00 | | | 1 | LUG, solder, SE #6 | | | | | |
| | - - - - - | | | - | mounting hardware: (not included w/lug) | | | | | |
| -11 | 211-0504-00 | | | 1 | SCREW, 6-32 x 1/4 inch, PHS | | | | | |
| | 210-0407-00 | | | 1 | NUT, hex., 6-32 x 1/4 inch | | | | | |
| -12 | 348-0055-00 | | | 1 | GROMMET, plastic, 1/4 inch diameter | | | | | |
| -13 | 131-0359-00 | | | 1 | CONNECTOR, terminal, feed thru | | | | | |
| | - - - - - | | | - | mounting hardware: (not included w/connector) | | | | | |
| | 358-0176-00 | | | 1 | BUSHING, plastic | | | | | |
| -14 | 131-0183-00 | | | 1 | CONNECTOR, terminal, feed thru | | | | | |
| | - - - - - | | | - | mounting hardware: (not included w/connector) | | | | | |
| | 358-0136-00 | | | 1 | BUSHING, plastic | | | | | |

FIG. 5 REAR CHASSIS (cont)

| Fig. & Index No. | Tektronix Part No. | Serial/Model Eff | No. Disc | Q † y | 1 2 3 4 5 | | | | | Description |
|------------------------|-----------------------|---------------------|-------------|-------------|-----------|--|--|--|--|---|
| | | | | | | | | | | |
| 5-15 | 214-0317-00 | | | 2 | | | | | | HEAT SINK |
| -16 | 352-0062-00 | | | 2 | | | | | | HOLDER, heat sink |
| | - - - - - | | | - | | | | | | mounting hardware: (not included w/holder) |
| -17 | 211-0012-00 | | | 2 | | | | | | SCREW, 4-40 x 3/8 inch, PHS |
| | 210-0004-00 | | | 2 | | | | | | LOCKWASHER, internal, #4 |
| -18 | 211-0033-00 | | | 2 | | | | | | SCREW, sems, 4-40 x 5/16 inch, PHS |
| | 210-0406-00 | | | 4 | | | | | | NUT, hex., 4-40 x 3/16 inch |
| -19 | 343-0097-00 | | | 2 | | | | | | CLAMP, heat sink |
| -20 | 210-0627-00 | | | 2 | | | | | | RIVET, heat sink |
| -21 | 210-0599-00 | | | 4 | | | | | | NUT, sleeve |
| -22 | 214-0368-00 | | | 2 | | | | | | SPRING, heat sink |
| -23 | 210-0004-00 | | | 4 | | | | | | LOCKWASHER, internal, #4 |
| -24 | 407-0280-00 | B010100 | B169999 | 1 | | | | | | BRACKET, circuit board |
| | 407-0280-02 | B170000 | | 1 | | | | | | BRACKET, circuit board |
| | - - - - - | | | - | | | | | | mounting hardware: (not included w/bracket) |
| | 211-0504-00 | | | 4 | | | | | | SCREW, 6-32 x 1/4 inch, PHS (not shown) |
| | 210-0802-00 | | | 1 | | | | | | WASHER, flat, 0.150 ID x 5/16 inch OD (not shown) |
| | 210-0457-00 | | | 2 | | | | | | NUT, keps, 6-32 x 5/16 inch (not shown) |
| -25 | 407-0285-00 | | | 1 | | | | | | BRACKET, vertical amplifier chassis |
| | - - - - - | | | - | | | | | | mounting hardware: (not included w/bracket) |
| -26 | 211-0504-00 | B010100 | B132889 | 2 | | | | | | SCREW, 6-32 x 1/4 inch, PHS |
| | 211-0510-00 | B132890 | | 2 | | | | | | SCREW, 6-32 x 3/8 inch, PHS |
| -27 | 352-0100-00 | | | 2 | | | | | | HOLDER, variable resistor |
| | - - - - - | | | - | | | | | | mounting hardware for each: (not included w/holder) |
| | 361-0007-00 | | | 1 | | | | | | SPACER, plastic, 0.156 inch long |
| | 119-0114-00 | | | 1 | | | | | | ASSEMBLY, delay-line |
| | - - - - - | | | - | | | | | | assembly includes: |
| -28 | 380-0109-00 | | | 1 | | | | | | HOUSING, delay-line |
| -29 | 407-0278-00 | | | 1 | | | | | | BRACKET, delay-line |
| -30 | 210-0457-00 | | | 1 | | | | | | NUT, keps, 6-32 x 5/16 inch |
| -31 | 131-0007-00 | | | 1 | | | | | | CONNECTOR, cable end, w/mounting hardware |
| -32 | 131-0272-00 | | | 1 | | | | | | CONNECTOR, cable, left hand mounting |
| | - - - - - | | | - | | | | | | mounting hardware: (not included w/assembly) |
| | 211-0008-00 | | | 1 | | | | | | SCREW, 4-40 x 1/4 inch, PHS (not shown) |
| -33 | 210-0586-00 | | | 1 | | | | | | NUT, keps, 4-40 x 1/4 inch |
| -34 | 211-0504-00 | | | 2 | | | | | | SCREW, 6-32 x 1/4 inch, PHS |
| -35 | 407-0289-00 | | | 1 | | | | | | BRACKET, delay-line housing |
| | - - - - - | | | - | | | | | | bracket includes: |
| -36 | 358-0282-00 | | | 1 | | | | | | BUSHING, insulating |
| | - - - - - | | | - | | | | | | mounting hardware: (not included w/bracket) |
| -37 | 211-0541-00 | | | 2 | | | | | | SCREW, 6-32 x 1/4 inch, 100° csk, FHS |
| -38 | 210-0457-00 | | | 2 | | | | | | NUT, keps, 6-32 x 5/16 inch |

FIG. 5 REAR CHASSIS (cont)

| Fig. & Index No. | Tektronix Part No. | Serial/Model Eff | No. Disc | Q | | | | | Description |
|------------------------|-----------------------|---------------------|-------------|----|---|---|---|---|---|
| | | | | t | 1 | 2 | 3 | 4 | |
| 5-39 | 670-0490-00 | | | 1 | | | | | ASSEMBLY, circuit board—Z AXIS |
| | - - - - - | | | - | | | | | assembly includes: |
| | 388-0789-00 | | | 1 | | | | | BOARD, circuit |
| -40 | 136-0183-00 | | | 4 | | | | | SOCKET, transistor, 3 pin |
| -41 | 136-0220-00 | | | 4 | | | | | SOCKET, transistor, 3 pin |
| -42 | 214-0506-00 | | | 20 | | | | | PIN, connector |
| -43 | 214-0579-00 | | | 3 | | | | | PIN, test point |
| | - - - - - | | | - | | | | | mounting hardware: (not included w/assembly) |
| -44 | 211-0116-00 | | | 3 | | | | | SCREW, sems, 4-40 x 5/16 inch, PHB |
| -45 | 386-1121-00 | | | 1 | | | | | SUPPORT, chassis |
| | - - - - - | | | - | | | | | mounting hardware: (not included w/support) |
| | 212-0004-00 | | | 4 | | | | | SCREW, 8-32 x 5/16 inch, PHS (not shown) |
| -46 | 348-0064-00 | | | 3 | | | | | GROMMET, plastic, 5/8 inch diameter |
| -47 | 348-0055-00 | | | 1 | | | | | GROMMET, plastic, 1/4 inch diameter |
| -48 | 358-0215-00 | | | 3 | | | | | BUSHING, plastic |
| -49 | 348-0063-00 | | | 5 | | | | | GROMMET, plastic, 1/2 inch diameter |
| -50 | 348-0056-00 | | | 2 | | | | | GROMMET, plastic, 3/8 inch diameter |
| -51 | 352-0031-00 | | | 2 | | | | | HOLDER, fuse, single |
| | - - - - - | | | - | | | | | mounting hardware: (not included w/holder) |
| -52 | 211-0538-00 | | | 1 | | | | | SCREW, 6-32 x 5/16 inch, 100° csk, FHS |
| | 210-0006-00 | | | 1 | | | | | LOCKWASHER, internal, #6 |
| -53 | 210-0407-00 | | | 1 | | | | | NUT, hex., 6-32 x 1/4 inch |
| -54 | 407-0288-00 | | | 1 | | | | | BRACKET, transformer |
| | - - - - - | | | - | | | | | mounting hardware: (not included w/bracket) |
| -55 | 212-0001-00 | | | 4 | | | | | SCREW, 8-32 x 1/4 inch, PHS |
| -56 | - - - - - | | | 1 | | | | | TRANSFORMER |
| | - - - - - | | | - | | | | | mounting hardware: (not included w/transformer) |
| -57 | 212-0576-00 | B010100 | B153229 | 4 | | | | | SCREW, 10-32 x 1 3/8 inches, HHS |
| | 212-0553-00 | B153230 | | 4 | | | | | SCREW, 10-32 x 1 1/2 inches, RHS |
| -58 | 210-0206-00 | | | 1 | | | | | LUG, solder, SE #10 |
| -59 | 220-0410-00 | | | 4 | | | | | NUT, keps, 10-32 x 3/8 inch |
| -60 | 441-0691-00 | | | 1 | | | | | CHASSIS, low voltage regulator |
| | - - - - - | | | - | | | | | mounting hardware: (not included w/chassis) |
| -61 | 211-0504-00 | | | 2 | | | | | SCREW, 6-32 x 1/4 inch, PHS |
| | 210-0802-00 | | | 1 | | | | | WASHER, flat, 0.150 ID x 5/16 inch OD (not shown) |
| -62 | 210-0457-00 | | | 2 | | | | | NUT, keps, 6-32 x 5/16 inch |

FIG. 5 REAR CHASSIS (cont)

| Fig. & Index No. | Tektronix Part No. | Serial/Model Eff | No. Disc | Q | | | | | Description | |
|------------------------|-----------------------|---------------------|-------------|----|---|---|---|---|-------------|--|
| | | | | t | Y | 1 | 2 | 3 | | 4 |
| 5-63 | - - - - - | | | 4 | | | | | | TRANSISTOR - mounting hardware for each: (not included w/transistor) |
| -64 | 211-0510-00 | | | 2 | | | | | | SCREW, 6-32 x 3/8 inch, PHS |
| -65 | 387-0345-00 | | | 1 | | | | | | PLATE, insulator |
| | 210-0811-00 | | | 2 | | | | | | WASHER, fiber, shouldered, #6 |
| | 210-0802-00 | | | 2 | | | | | | WASHER, flat, 0.150 ID x 5/16 inch OD |
| -66 | 210-0202-00 | | | 1 | | | | | | LUG, solder, SE #6 |
| -67 | 210-0006-00 | | | 1 | | | | | | LOCKWASHER, internal, #6 |
| -68 | 210-0407-00 | | | 2 | | | | | | NUT, hex., 6-32 x 1/4 inch |
| -69 | 214-0289-00 | | | 2 | | | | | | HEAT SINK, transistor - mounting hardware for each: (not included w/heat sink) |
| -70 | 210-0909-00 | | | 2 | | | | | | WASHER, mica, 0.196 ID x 0.625 inch OD |
| | 210-0805-00 | | | 1 | | | | | | WASHER, flat, 0.204 ID x 0.438 inch OD |
| -71 | 220-0410-00 | | | 1 | | | | | | NUT, keps, 10-32 x 3/8 inch |
| -72 | 202-0142-01 | | | 1 | | | | | | BOX, high voltage - mounting hardware: (not included w/box) |
| | - - - - - | | | 6 | | | | | | SCREW, 6-32 x 1/4 inch, PHS (not shown) |
| | 211-0504-00 | | | | | | | | | |
| -73 | - - - - - | | | 1 | | | | | | CAPACITOR - mounting hardware: (not included w/capacitor) |
| | - - - - - | | | 2 | | | | | | LOCKWASHER, internal, #6 |
| | 210-0006-00 | | | 2 | | | | | | NUT, hex., 6-32 x 1/4 inch |
| -74 | 210-0407-00 | | | | | | | | | |
| -75 | 343-0013-00 | | | 3 | | | | | | CLAMP, cable, plastic, 3/8 inch diameter - mounting hardware for each: (not included w/clamp) |
| | - - - - - | | | 1 | | | | | | WASHER, "D" shape, 0.191 ID x 33/64 W x 33/64 inch long |
| | 210-0863-00 | | | 1 | | | | | | NUT, keps, 6-32 x 5/16 inch |
| -76 | 210-0457-00 | | | | | | | | | |
| -77 | 343-0006-00 | | | 1 | | | | | | CLAMP, cable, plastic, 1/2 inch diameter - mounting hardware: (not included w/clamp) |
| | - - - - - | | | 1 | | | | | | WASHER, "D" shape, 0.191 ID x 33/64 W x 33/64 inch long |
| | 210-0863-00 | | | 1 | | | | | | SCREW, 6-32 x 5/16 inch, PHS |
| | 211-0507-00 | | | | | | | | | |
| -78 | 670-0489-00 | | | 1 | | | | | | ASSEMBLY, circuit board—LV POWER SUPPLY - assembly includes: |
| | - - - - - | | | 1 | | | | | | BOARD, circuit |
| | 388-0787-00 | | | 12 | | | | | | PIN, connector |
| -79 | 214-0506-00 | | | 8 | | | | | | SOCKET, transistor, 3 pin |
| -80 | 136-0220-00 | | | | | | | | | - mounting hardware: (not included w/assembly) |
| | - - - - - | | | 3 | | | | | | SCREW, sems, 4-40 x 5/16 inch, PHB |
| -81 | 211-0116-00 | | | | | | | | | |

<http://manoman.sqhill.com>

FIG. 5 REAR CHASSIS (cont)

| Fig. & Index No. | Tektronix Part No. | Serial/Model Eff | No. Disc | Q | | | | | Description | |
|------------------|--------------------|------------------|----------|---|---|---|---|---|-------------|--|
| | | | | † | Y | 1 | 2 | 3 | | 4 |
| 5-82 | - - - - - | | | 1 | | | | | | RESISTOR, variable |
| | - - - - - | | | - | | | | | | mounting hardware: (not included w/resistor) |
| | 210-0223-00 | | | 1 | | | | | | LUG, solder, 1/4 ID x 7/16 inch OD, SE |
| | 210-0940-00 | | | 1 | | | | | | WASHER, flat, 1/4 ID x 3/8 inch OD |
| -83 | 210-0583-00 | | | 1 | | | | | | NUT, hex., 1/4-32 x 5/16 inch |
| -84 | 344-0140-00 | | | 1 | | | | | | CLIP, plastic |
| | - - - - - | | | - | | | | | | mounting hardware: (not included w/clip) |
| | 213-0055-00 | | | 1 | | | | | | SCREW, thread forming, 2-32 x 3/16 inch, PHS |
| -85 | 214-0210-00 | | | 1 | | | | | | ASSEMBLY, solder spool |
| | - - - - - | | | - | | | | | | assembly includes: |
| | 214-0209-00 | | | 1 | | | | | | SPOOL, solder |
| | - - - - - | | | - | | | | | | mounting hardware: (not included w/assembly) |
| | 361-0007-00 | | | 1 | | | | | | SPACER, plastic, 0.156 inch long |
| -86 | 260-0879-00 | | | 1 | | | | | | SWITCH, thermostatic |
| | - - - - - | | | - | | | | | | mounting hardware: (not included w/switch) |
| -87 | 213-0044-00 | | | 2 | | | | | | SCREW, thread forming, 5-32 x 3/16 inch, PHS |
| -88 | 210-0202-00 | | | 2 | | | | | | LUG, solder, SE #6 |
| | - - - - - | | | - | | | | | | mounting hardware for each: (not included w/lug) |
| | 213-0044-00 | | | 1 | | | | | | SCREW, thread forming, 5-32 x 3/16 inch, PHS |
| | 635-0433-00 | | | 1 | | | | | | ASSEMBLY, fan motor |
| | - - - - - | | | - | | | | | | assembly includes: |
| -89 | 147-0027-00 | | | 1 | | | | | | MOTOR, fan |
| -90 | 407-0308-01 | | | 1 | | | | | | BRACKET, fan motor |
| -91 | 369-0025-00 | | | 1 | | | | | | FAN, impeller |
| | 210-0054-00 | | | 3 | | | | | | LOCKWASHER, split, #4 (not shown) |
| | 211-0008-00 | | | 3 | | | | | | SCREW, 4-40 x 1/4 inch, PHS |
| | - - - - - | | | - | | | | | | mounting hardware: (not included w/assembly) |
| -92 | 211-0012-00 | | | 3 | | | | | | SCREW, 4-40 x 3/8 inch, PHS |
| -93 | 210-0851-00 | | | 6 | | | | | | WASHER, flat, 0.119 ID x 3/8 inch OD |
| | 210-0201-00 | XB150000 | | 1 | | | | | | LUG, solder, SE #4 |
| -94 | 348-0093-00 | | | 3 | | | | | | GROMMET, rubber, 0.140 ID x 0.375 inch OD |
| -95 | 220-0471-00 | | | 3 | | | | | | NUT, stepped, round, 4-40 x 0.217 inch long |
| -96 | 380-0114-00 | | | 1 | | | | | | HOUSING, air flow |
| -97 | 131-0181-00 | | | 1 | | | | | | CONNECTOR, terminal, stand off |
| | - - - - - | | | - | | | | | | mounting hardware: (not included w/connector) |
| | 358-0136-00 | | | 1 | | | | | | BUSHING, plastic |
| -98 | 441-0690-00 | | | 1 | | | | | | CHASSIS, rear |
| | - - - - - | | | - | | | | | | mounting hardware: (not included w/chassis) |
| | 212-0004-00 | | | 4 | | | | | | SCREW, 8-32 x 5/16 inch, PHS (not shown) |

FIG. 5 REAR CHASSIS (cont)

| Fig. & Index No. | Tektronix Part No. | Serial/Model No. Eff | No. Disc | Q | | | | | Description | |
|------------------------|-----------------------|-------------------------|-------------|----|---|---|---|---|-------------|--|
| | | | | t | y | 1 | 2 | 3 | | 4 |
| 5-99 | 179-1139-00 | | | 1 | | | | | | CABLE HARNESS, low voltage power |
| | - - - - - | | | - | | | | | | cable harness includes: |
| | 131-0371-00 | | | 10 | | | | | | CONNECTOR, single contact |
| -100 | 179-1147-00 | | | 1 | | | | | | CABLE HARNESS, transformer |
| -101 | 179-1135-00 | | | 1 | | | | | | CABLE HARNESS, main |
| | - - - - - | | | - | | | | | | cable harness includes: |
| | 131-0371-00 | | | 43 | | | | | | CONNECTOR, single contact |
| -102 | 124-0147-00 | | | 2 | | | | | | STRIP, ceramic, 7/16 inch h, w/13 notches |
| | - - - - - | | | - | | | | | | each strip includes: |
| | 355-0046-00 | | | 2 | | | | | | STUD, plastic |
| | - - - - - | | | - | | | | | | mounting hardware for each: (not included w/strip) |
| | 361-0007-00 | | | 2 | | | | | | SPACER, plastic, 0.156 inch long |
| -103 | 124-0145-00 | | | 2 | | | | | | STRIP, ceramic, 7/16 inch h, w/20 notches |
| | - - - - - | | | - | | | | | | each strip includes: |
| | 355-0046-00 | | | 2 | | | | | | STUD, plastic |
| | - - - - - | | | - | | | | | | mounting hardware for each: (not included w/strip) |
| | 361-0007-00 | | | 2 | | | | | | SPACER, plastic, 0.156 inch long |

FIG. 6 FRAME & CABINET

| Fig. & Index No. | Tektronix Part No. | Serial/Model No. Eff | No. Disc | Q | | | | | Description |
|------------------|--------------------|----------------------|----------|----|---|---|---|---|--|
| | | | | t | Y | 1 | 2 | 3 | |
| 6-1 | 200-0633-02 | | | 1 | | | | | ASSEMBLY, front cover (TYPE 454 only) |
| | - - - - - | | | - | | | | | assembly includes: |
| -2 | 214-0531-01 | | | 2 | | | | | LATCH ASSEMBLY |
| -3 | 348-0013-00 | | | 4 | | | | | FOOT, rubber |
| -4 | 214-0755-00 | | | 2 | | | | | PIN, hinge, plastic |
| -5 | 252-0571-00 | | | FT | | | | | EXTENSION, neoprene, 3 feet |
| -6 | 348-0091-00 | | | 1 | | | | | CUSHION, cover, bottom |
| -7 | 200-0710-00 | | | 1 | | | | | DOOR, accessory storage |
| | - - - - - | | | - | | | | | door includes: |
| -8 | 352-0093-00 | | | 1 | | | | | HOLDER, fuse storage |
| -9 | 204-0282-00 | | | 1 | | | | | BODY, latch |
| -10 | 214-0787-00 | | | 1 | | | | | STEM, latch |
| -11 | 348-0118-00 | | | 1 | | | | | PAD, cushioning, door |
| -12 | 386-1177-00 | | | 1 | | | | | PLATE, cabinet, bottom |
| -13 | 348-0080-01 | | | 4 | | | | | FOOT, rubber |
| | - - - - - | | | - | | | | | mounting hardware for each: (not included w/foot) |
| | 210-0005-00 | | | 1 | | | | | LOCKWASHER, external, #6 |
| -14 | 211-0504-00 | | | 1 | | | | | SCREW, 6-32 x 1/4 inch, PHS |
| -15 | 386-1178-00 | | | 1 | | | | | PLATE, cabinet, top |
| -16 | 367-0072-00 | | | 1 | | | | | HANDLE, carrying |
| | - - - - - | | | - | | | | | mounting hardware: (not included w/handle) |
| -17 | 211-0512-00 | | | 4 | | | | | SCREW, 6-32 x 1/2 inch, 100° csk, FHS |
| -18 | 200-0602-00 | | | 2 | | | | | COVER, handle latch |
| -19 | 214-0516-00 | | | 2 | | | | | SPRING, handle index |
| -20 | 214-0578-00 | | | 2 | | | | | HUB, index handle |
| -21 | 214-0513-00 | | | 1 | | | | | INDEX, handle ring |
| | - - - - - | | | - | | | | | mounting hardware for each: (not included w/hub) |
| | 213-0129-00 | | | 1 | | | | | SCREW, hex., socket head, 1/4-20 x 3/4 inch |
| -22 | 214-0910-01 | | | 2 | | | | | SCREW, cabinet latch |
| | 354-0175-00 | | | 2 | | | | | RING, retaining |
| -23 | 426-0260-00 | | | 2 | | | | | FRAME, rail |
| | - - - - - | | | - | | | | | mounting hardware for each: (not included w/frame) |
| -24 | 212-0560-00 | B010100 | B122429 | 4 | | | | | SCREW, 10-32 x 5/16 inch, 100° csk, FHS |
| | 212-0506-00 | B122430 | | 4 | | | | | SCREW, 10-32 x 3/8 inch, 100° csk, FHS |
| -25 | 426-0317-01 | | | 1 | | | | | FRAME, cabinet, rear |
| -26 | 348-0078-00 | B010100 | B119999 | 4 | | | | | FOOT, body & cord holder |
| | 348-0078-01 | B120000 | B179999X | 4 | | | | | FOOT, body & cord holder |
| -27 | 348-0079-00 | B010100 | B119999 | 4 | | | | | FOOT, cap |
| | 348-0079-01 | B120000 | B179999X | 4 | | | | | FOOT, cap |
| | 348-0190-00 | XB180000 | | 4 | | | | | FOOT, cabinet, plastic |
| -28 | 212-0082-00 | | | 4 | | | | | SCREW, 8-32 x 1 1/4 inches, PHS |
| | 212-0001-00 | | | 4 | | | | | SCREW, 8-32 x 1/4 inch, PHS |
| | 129-0146-00 | | | 4 | | | | | POST, metal, 3/4 inch long (not shown) |
| -29 | 129-0020-00 | | | 1 | | | | | POST, binding |
| | - - - - - | | | - | | | | | post includes: |
| | 200-0072-00 | | | 1 | | | | | CAP, binding post |
| | 355-0503-00 | | | 1 | | | | | STEM, adapter |
| | - - - - - | | | - | | | | | mounting hardware: (not included w/post) |
| -30 | 220-0410-00 | | | 1 | | | | | NUT, keps, 10-32 x 3/8 inch |

FIG. 6 FRAME & CABINET (cont)

| Fig. & Index No. | Tektronix Part No. | Serial/Model No. | | Q t Y | Description |
|------------------------|-----------------------|------------------|---------|-------------|---|
| | | Eff | Disc | | |
| 6-31 | 129-0064-00 | | | 1 | POST, binding |
| | - - - - - | | | - | mounting hardware: (not included w/post) |
| -32 | 358-0181-00 | | | 1 | BUSHING, plastic |
| | 210-0203-00 | | | 1 | LUG, solder, SE #6 long |
| -33 | 210-0457-00 | | | 1 | NUT, keps, 6-32 x 5/16 inch |
| -34 | 346-0043-00 | | | 1 | STRAP, ground |
| -35 | 386-1128-00 | | | 1 | PLATE, rear panel |
| | - - - - - | | | - | mounting hardware: (not included w/plate) |
| -36 | 211-0565-00 | | | 4 | SCREW, 6-32 x 1/4 inch, THS |
| -37 | 386-1122-00 | | | 1 | PLATE |
| | - - - - - | | | - | mounting hardware: (not included w/plate) |
| -38 | 211-0504-00 | | | 2 | SCREW, 6-32 x 1/4 inch, PHS |
| -39 | 358-0323-00 | | | 1 | FASTENER, power cord |
| -40 | 161-0033-00 | | | 1 | CORD, power, 3 conductor |
| | 343-0170-00 | XB184800 | | 1 | RETAINER, cable to cable (not shown) |
| -41 | 204-0279-00 | | | 1 | BODY, line voltage selector |
| | - - - - - | | | - | mounting hardware: (not included w/body) |
| | 210-0006-00 | | | 2 | LOCKWASHER, internal, #6 (not shown) |
| | 210-0407-00 | | | 2 | NUT, hex., 6-32 x 1/4 inch (not shown) |
| -42 | 200-0704-00 | B010100 | B139999 | 1 | COVER, line voltage selector |
| | 200-0764-00 | B140000 | | | COVER, line voltage selector |
| | - - - - - | | | - | cover includes: |
| -43 | 352-0102-00 | | | 2 | HOLDER, fuse, plastic |
| | - - - - - | | | - | mounting hardware for each: (not included w/holder) |
| -44 | 213-0035-00 | | | 2 | SCREW, thread cutting, 4-40 x 1/4 inch, PHS |
| -45 | 378-0036-01 | | | 1 | FILTER, air |
| -46 | 380-0082-00 | | | 1 | HOUSING, fan filter |
| | - - - - - | | | - | mounting hardware: (not included w/housing) |
| -47 | 213-0107-00 | | | 4 | SCREW, thread forming, 4-40 x 1/4 inch, FHS |
| -48 | 179-1140-00 | | | 1 | CABLE HARNESS, w/connector, line voltage selector |
| -49 | 343-0004-00 | | | 1 | CLAMP, cable, plastic, 5/16 inch diameter |
| | - - - - - | | | - | mounting hardware: (not included w/clamp) |
| | 211-0510-00 | | | 1 | SCREW, 6-32 x 3/8 inch, PHS |
| | 210-0863-00 | | | 1 | WASHER, "D" shape, 0.191 ID x 33/64 W x 33/64 inch long |
| -50 | 210-0457-00 | | | 1 | NUT, keps, 6-32 x 5/16 inch |

FIG. 7 TYPE R454 MECHANICAL PARTS

| Fig. & Index No. | Tektronix Part No. | Serial/Model Eff | No. Disc | Q | | | | | Description |
|------------------------|-----------------------|---------------------|-------------|---|---|---|---|---|---|
| | | | | f | 1 | 2 | 3 | 4 | |
| 7- | - - - - - | | | - | | | | | TYPE R454 |
| | - - - - - | | | - | | | | | includes: |
| -1 | - - - - - | | | 1 | | | | | TYPE 454 Oscilloscope |
| -2 | 426-0378-01 | | | 1 | | | | | FRAME, front |
| -3 | 334-1120-01 | | | 1 | | | | | PLATE, identification |
| -4 | 134-0067-00 | | | 4 | | | | | PLUG, grey plastic |
| -5 | 367-0022-00 | | | 2 | | | | | HANDLE |
| | - - - - - | | | - | | | | | mounting hardware for each: (not included w/handle) |
| -6 | 213-0090-00 | | | 2 | | | | | SCREW, 10-32 x 1/2 inch, HHS |
| | - - - - - | | | - | | | | | mounting hardware: (not included w/plate) |
| -7 | 386-1062-00 | | | 1 | | | | | PLATE, front frame backing, top |
| | - - - - - | | | - | | | | | mounting hardware: (not included w/plate) |
| -8 | 212-0002-00 | | | 1 | | | | | SCREW, 8-32 x 1/4 inch, 100° csk, FHS |
| | - - - - - | | | - | | | | | mounting hardware: (not included w/plate) |
| -9 | 386-1063-00 | | | 1 | | | | | PLATE, front frame backing, bottom |
| | - - - - - | | | - | | | | | mounting hardware: (not included w/plate) |
| -10 | 212-0002-00 | | | 1 | | | | | SCREW, 8-32 x 1/4 inch, 100° csk, FHS |
| | - - - - - | | | - | | | | | mounting hardware: (not included w/cabinet) |
| -11 | 390-0012-00 | | | 1 | | | | | CABINET, top |
| | - - - - - | | | - | | | | | mounting hardware: (not included w/cabinet) |
| -12 | 212-0001-00 | | | 2 | | | | | SCREW, 8-32 x 1/4 inch, PHS |
| -13 | 211-0502-00 | | | 1 | | | | | SCREW, 6-32 x 3/16 inch, 100° csk, FHS |
| | - - - - - | | | - | | | | | mounting hardware: (not included w/cabinet) |
| -14 | 390-0013-00 | | | 1 | | | | | CABINET, bottom |
| | - - - - - | | | - | | | | | mounting hardware: (not included w/cabinet) |
| -15 | 212-0001-00 | | | 2 | | | | | SCREW, 8-32 x 1/4 inch, PHS |
| | 211-0502-00 | | | 1 | | | | | SCREW, 6-32 x 3/16 inch, 100° csk, FHS (not shown) |
| | - - - - - | | | - | | | | | mounting hardware: (not included w/washer) |
| -16 | 386-1261-00 | | | 1 | | | | | PLATE, rear |
| -17 | 210-0808-00 | | | 1 | | | | | WASHER, centering |
| | - - - - - | | | - | | | | | mounting hardware: (not included w/washer) |
| -18 | 211-0507-00 | | | 1 | | | | | SCREW, 6-32 x 5/16 inch, PHS |
| -19 | 210-0457-00 | | | 1 | | | | | NUT, keps, 6-32 x 5/16 inch |
| | - - - - - | | | - | | | | | mounting hardware: (not included w/plate) |
| -20 | 386-1064-00 | | | 1 | | | | | PLATE, side |
| | - - - - - | | | - | | | | | mounting hardware: (not included w/plate) |
| -21 | 212-0023-00 | | | 1 | | | | | SCREW, 8-32 x 3/8 inch, PHS |
| -22 | 212-0040-00 | | | 1 | | | | | SCREW, 8-32 x 3/8 inch, 100° csk, FHS |
| -23 | 212-0043-00 | | | 4 | | | | | SCREW, 8-32 x 1/2 inch, 100° csk, FHS |
| -24 | 210-0458-00 | | | 6 | | | | | NUT, keps, 8-32 x 1 1/32 inch |

FIG. 7 R454 MECHANICAL PARTS (cont)

| Fig. & Index No. | Tektronix Part No. | Serial/Model No. | | Q † y | Description |
|------------------------|-----------------------|------------------|------|-------------|---|
| | | Eff | Disc | | |
| 7-25 | 426-0358-01 | | | 1 | FRAME, support, right |
| | - - - - - | | | - | mounting hardware: (not included w/frame) |
| -26 | 212-0040-00 | | | 4 | SCREW, 8-32 x 3/8 inch, 100° csk, FHS |
| -27 | 213-0129-00 | | | 2 | SCREW, 1/4-20 x 3/4 inch, HSS |
| -28 | 361-0120-00 | | | 1 | SPACER, stepped |
| -29 | 426-0363-01 | | | 1 | FRAME, support, left |
| | - - - - - | | | - | mounting hardware: (not included w/frame) |
| -30 | 212-0040-00 | | | 4 | SCREW, 8-32 x 3/8 inch, 100° csk, FHS |
| -31 | 213-0129-00 | | | 2 | SCREW, 1/4-20 x 3/4 inch, HSS |
| -32 | 361-0120-00 | | | 1 | SPACER, stepped |
| -33 | 214-0881-00 | | | 1 | HINGE |
| | - - - - - | | | - | mounting hardware: (not included w/hinge) |
| -34 | 211-0503-00 | | | 2 | SCREW, 6-32 x 3/16 inch, PHS |
| -35 | 351-0104-00 | | | 1 pr | GUIDE, w/mounting hardware |
| -36 | 355-0114-00 | | | 4 | STUD |
| | - - - - - | | | - | mounting hardware for each: (not included w/stud) |
| -37 | 210-0011-00 | | | 1 | LOCKWASHER, internal, 1/4 ID x 15/32 inch OD |
| -38 | 210-0411-00 | | | 1 | NUT, hex., 1/4-20 x 7/16 inch |
| -39 | 212-0010-00 | | | 4 | SCREW, 8-32 x 5/8 inch, PHS |

SECTION 9

DIAGRAMS

The following symbols are used on the diagrams:



Screwdriver adjustment

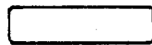

Front-, side- or rear-panel control or connector



Clockwise control rotation in direction of arrow



Refer to indicated diagram

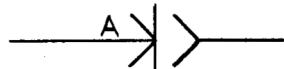

Connection to circuit board made with pin connector at indicated pin



Connection soldered to circuit board



Blue line encloses components located on circuit board

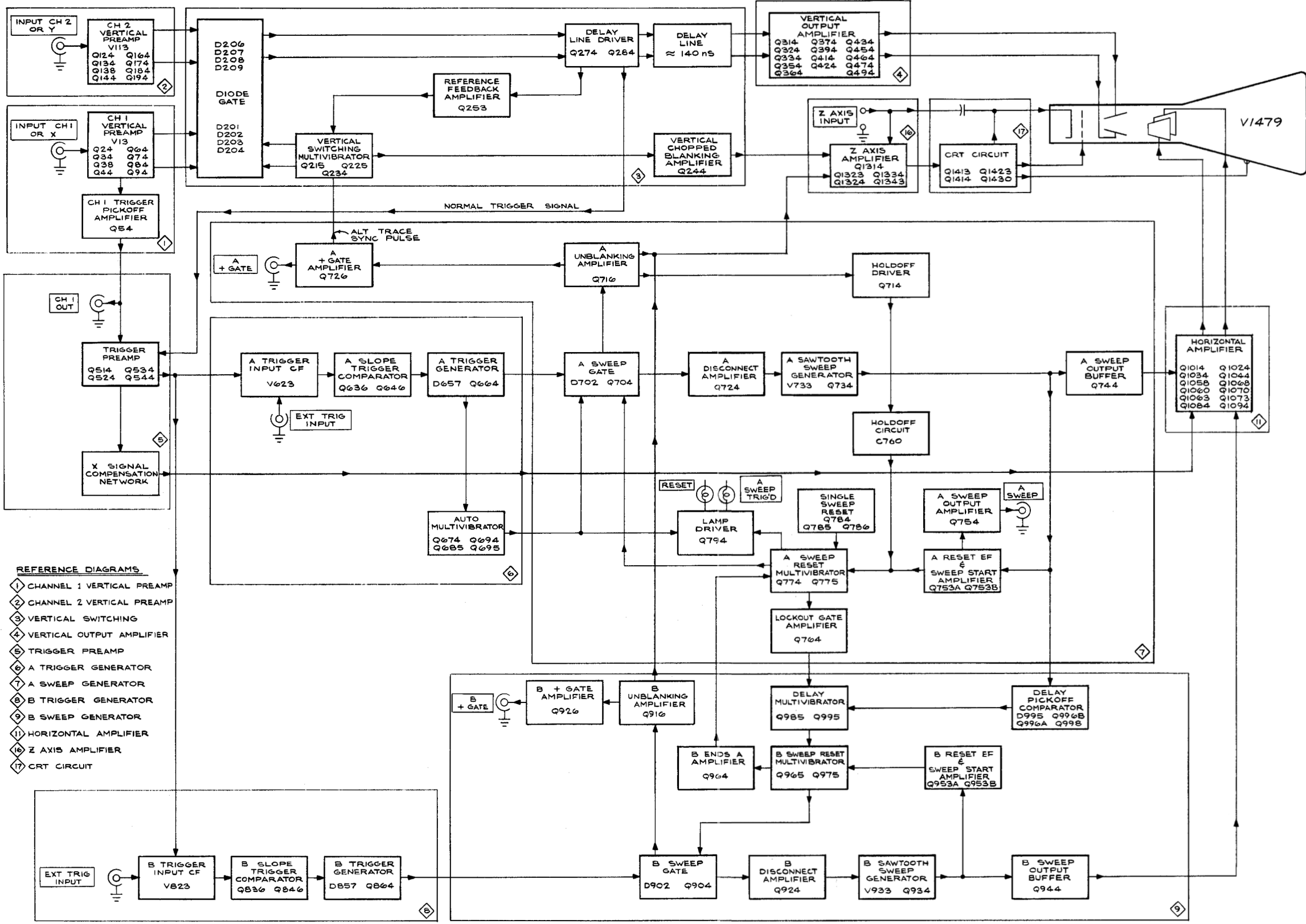

- REFERENCE DIAGRAMS**
- ① CHANNEL 1 VERTICAL PREAMP
 - ② CHANNEL 2 VERTICAL PREAMP
 - ③ VERTICAL SWITCHING
 - ④ VERTICAL OUTPUT AMPLIFIER
 - ⑤ TRIGGER PREAMP
 - ⑥ A TRIGGER GENERATOR
 - ⑦ A SWEEP GENERATOR
 - ⑧ B TRIGGER GENERATOR
 - ⑨ B SWEEP GENERATOR
 - ⑩ HORIZONTAL AMPLIFIER
 - ⑪ Z AXIS AMPLIFIER
 - ⑫ CRT CIRCUIT

VOLTAGE AND WAVEFORM TEST CONDITIONS

Typical voltage measurements and waveform photographs were obtained under the following conditions unless noted otherwise on the individual diagrams:

Test Oscilloscope (with 10X Probe)

| | |
|--|---|
| Frequency response | DC to 50 MHz |
| Deflection factor (with probe) | 50 millivolts to 10 volts/division |
| Input impedance | 10 Megohms, 7.5 picofarads |
| Probe ground | Type 454 chassis ground |
| Trigger Source | External from A + GATE connector to indicate true time relationship between signals |
| Recommended type (as used for waveforms on diagrams) | Tektronix Type 545B with Type 1A1 plug-in unit |

Voltmeter

| | |
|---|--|
| Type | Non-loading AC (RMS)-DC VTVM |
| Sensitivity | 20,000 ohms/volt |
| Range | 0 to 300 volts |
| Reference voltage | Type 454 chassis ground |
| Recommended type (as used for voltages on diagrams) | General Radio Type 1806-A Electronic Voltmeter |

Type 454 Conditions

| | |
|------------------|---|
| Line voltage | 115 volts |
| Signal applied | Calibrator output signal connected to INPUT CH 1 and INPUT CH 2 connectors for waveforms only |
| Connectors | No connections |
| Trace position | Centered |
| Control settings | As follows except as noted, otherwise on individual diagrams: |

CRT Controls

| | |
|----------------|----------------------------|
| INTENSITY | Midrange |
| FOCUS | Adjust for focused display |
| SCALE ILLUM | As desired |
| BW-BEAM FINDER | FULL |

Vertical Controls (both channels if applicable)

| | |
|----------------|-----------|
| VOLTS/DIV | .2 |
| VARIABLE | CAL |
| POSITION | Midrange |
| Input Coupling | DC |
| MODE | CH 1 |
| TRIGGER | NORM |
| INVERT | Pushed in |

Triggering Controls (both A and B if applicable)

| | |
|----------|-----|
| LEVEL | 0 |
| SLOPE | + |
| COUPLING | AC |
| SOURCE | INT |

Sweep Controls

| | |
|-----------------------|------------------------------|
| DELAY-TIME MULTIPLIER | 0.10 |
| A TIME/DIV | 1 ms |
| B TIME/DIV | 1 ms |
| A VARIABLE | CAL |
| A SWEEP MODE | AUTO TRIG |
| B SWEEP MODE | TRIGGERABLE AFTER DELAY TIME |
| HORIZ DISPLAY | A |
| MAG | OFF |
| A SWEEP LENGTH | FULL |
| POSITION | Midrange |
| FINE | Midrange |
| POWER | ON |

Side-Panel Controls

| | |
|---------------------|-----|
| B TIME/DIV VARIABLE | CAL |
|---------------------|-----|

All voltages given on the diagrams are in volts. Waveforms shown are actual waveform photographs taken with a Tektronix Oscilloscope Camera System and Projected Graticule.

Voltages and waveforms on the diagrams (shown in blue) are not absolute and may vary between instruments because of differing component tolerances, internal calibration or front-panel control settings.

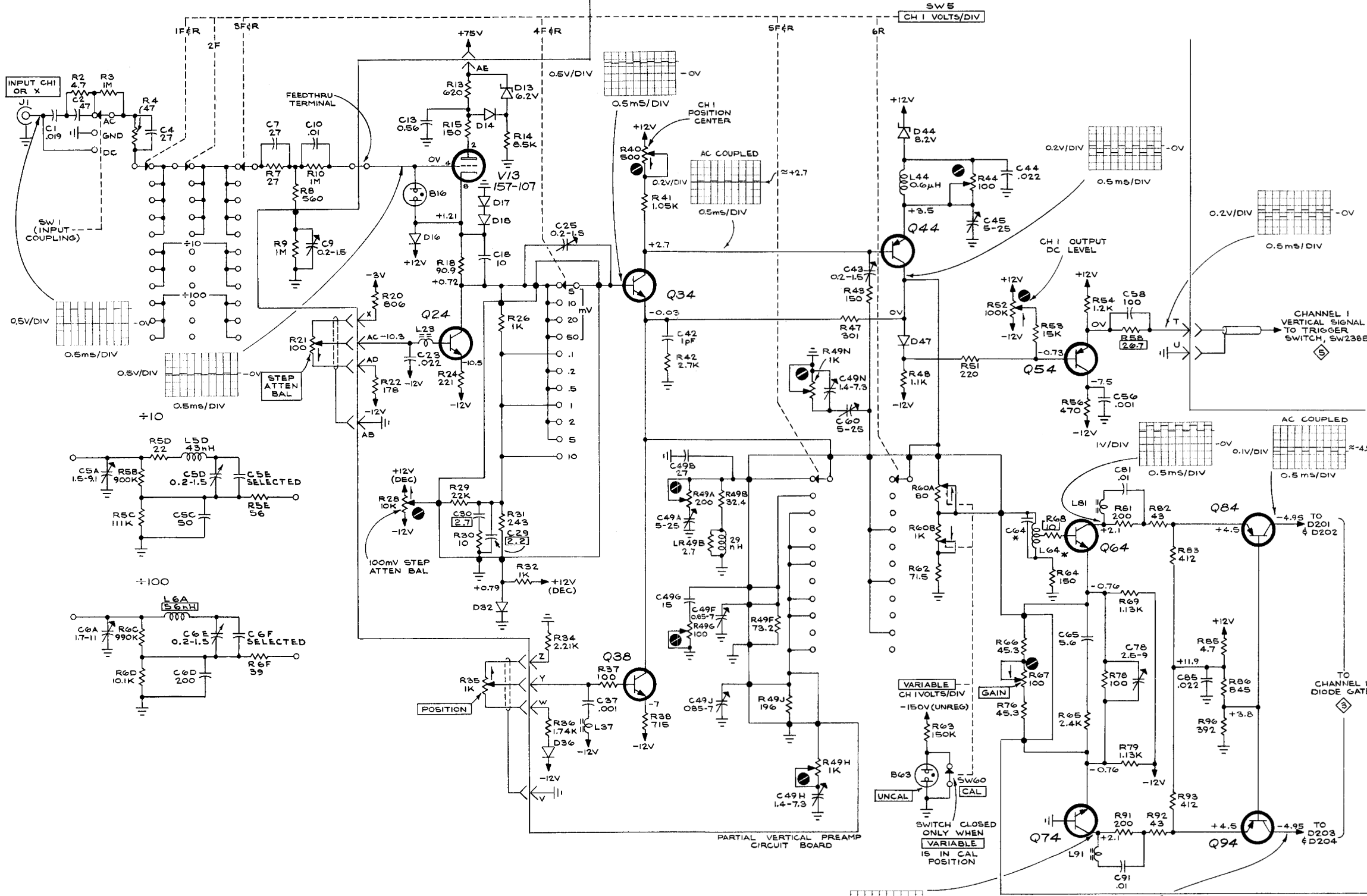

* COMPONENT IS ON SEPARATE ETCHED CIRCUIT BOARD

VOLTAGES and WAVEFORMS obtained under conditions given on left side of this diagram, except as follows;
 VOLTAGES only.....No signal applied.

- REFERENCE DIAGRAMS
- ③ VERTICAL SWITCHING
 - ⑤ TRIGGER PREAMP
 - ④ POWER DISTRIBUTION & DECOUPLING

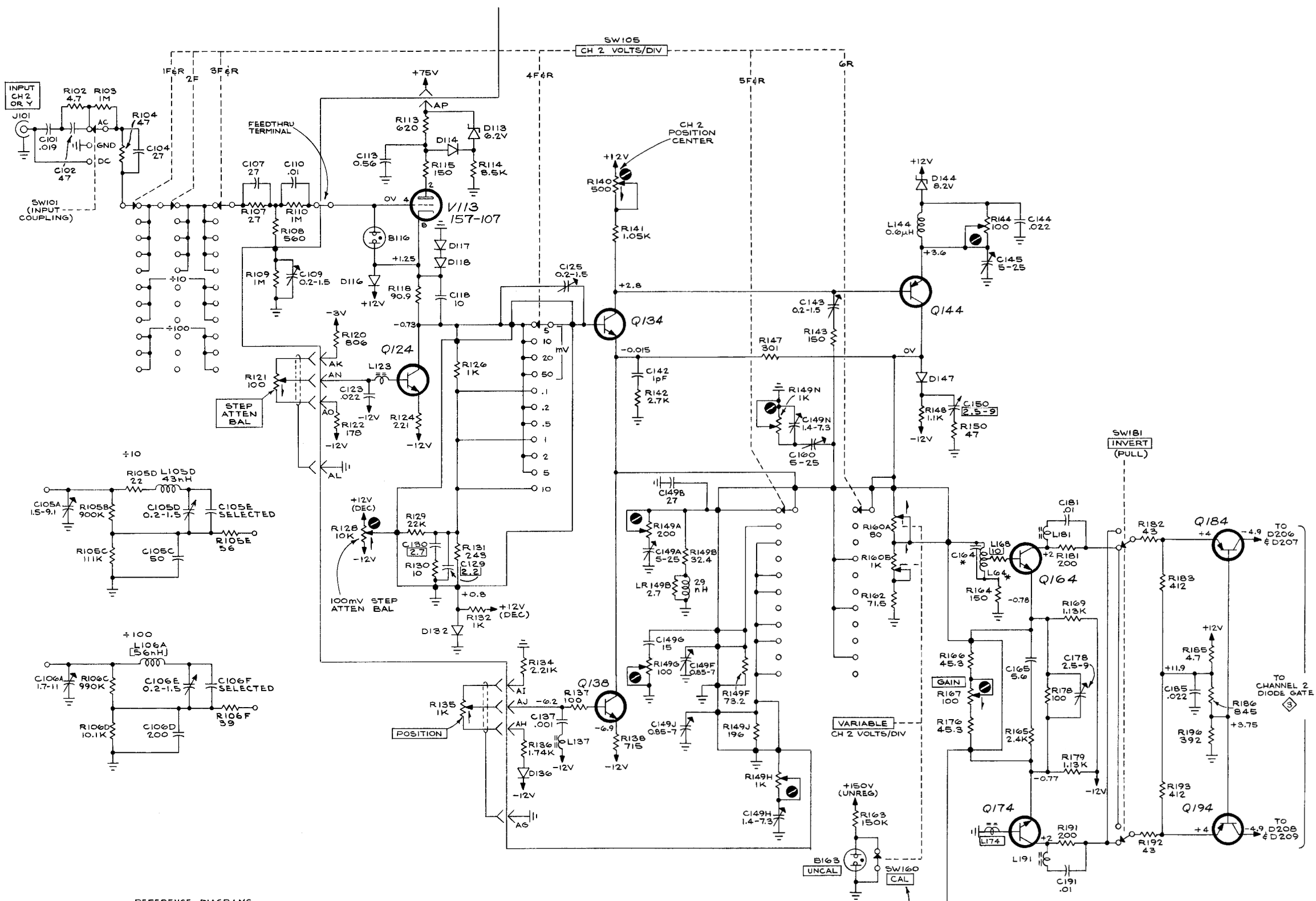

REFERENCE DIAGRAMS

- ③ VERTICAL SWITCHING
- ④ POWER DISTRIBUTION & DECOUPLING

VOLTAGES and WAVEFORMS obtained under conditions given on Diagram ④, except as follows:
 VOLTAGES and WAVEFORMS
 MODE.....CH 2
 VOLTAGES only.....No signal applied
 WAVEFORMS only.....See CH 1 VERTICAL PREAMP, Diagram ④

* COMPONENT IS ON SEPARATE ETCHED CIRCUIT BOARD

SWITCH CLOSED ONLY WHEN VARIABLE IS IN CAL POSITION

PARTIAL VERTICAL PREAMP CIRCUIT BOARD

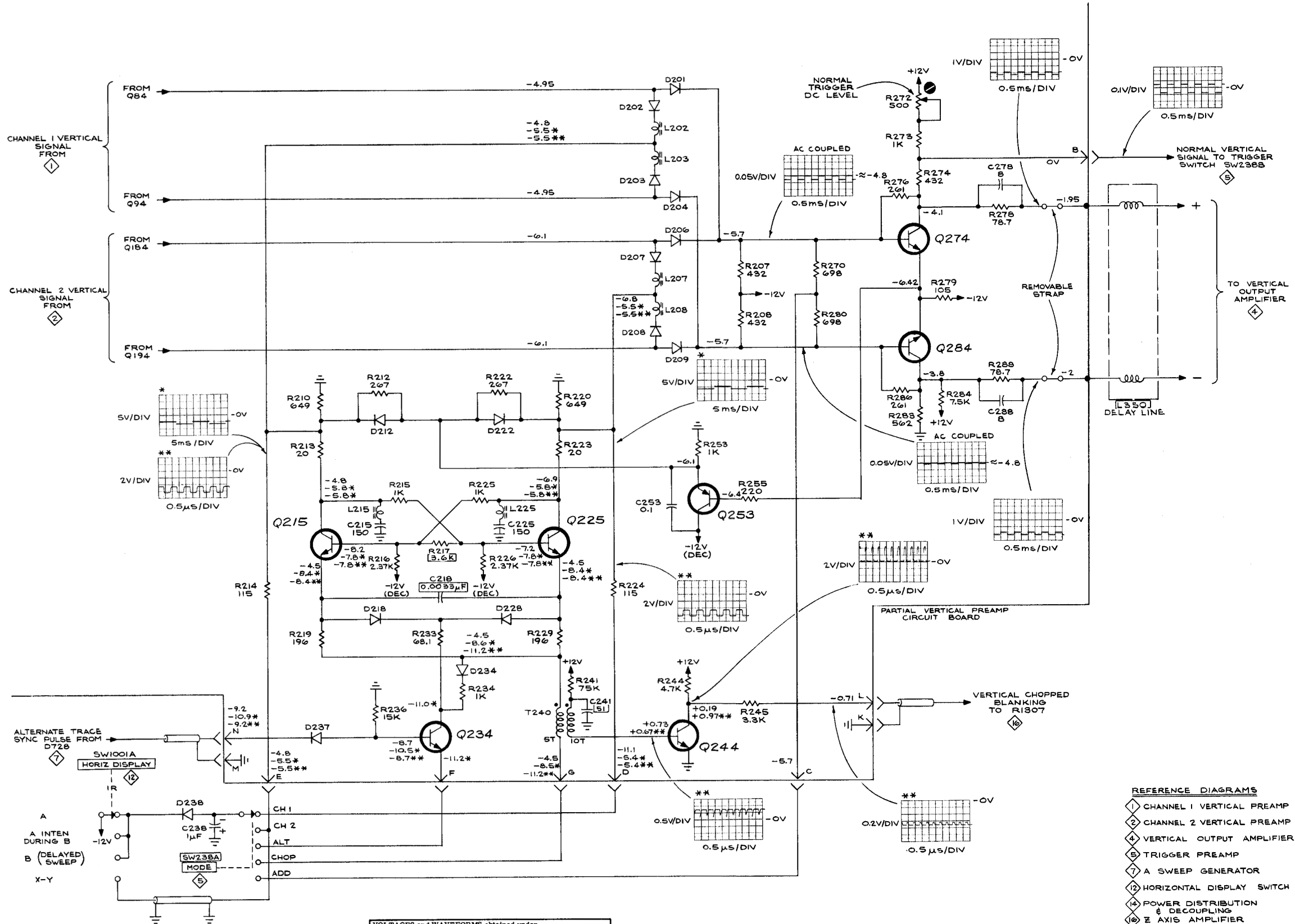

VOLTAGES and WAVEFORMS obtained under conditions given on Diagram \diamond , except as follows:
 VOLTAGES and WAVEFORMS
 * MODE.....ALT
 ** MODE.....CHOP
 VOLTAGES only.....No signal applied
 WAVEFORMS only.....Test oscilloscope triggered externally from signal
 (* and **)

- REFERENCE DIAGRAMS
- $\diamond 1$ CHANNEL 1 VERTICAL PREAMP
 - $\diamond 2$ CHANNEL 2 VERTICAL PREAMP
 - $\diamond 4$ VERTICAL OUTPUT AMPLIFIER
 - $\diamond 5$ TRIGGER PREAMP
 - $\diamond 7$ A SWEEP GENERATOR
 - $\diamond 12$ HORIZONTAL DISPLAY SWITCH
 - $\diamond 14$ POWER DISTRIBUTION & DECOUPLING
 - $\diamond 16$ Z AXIS AMPLIFIER

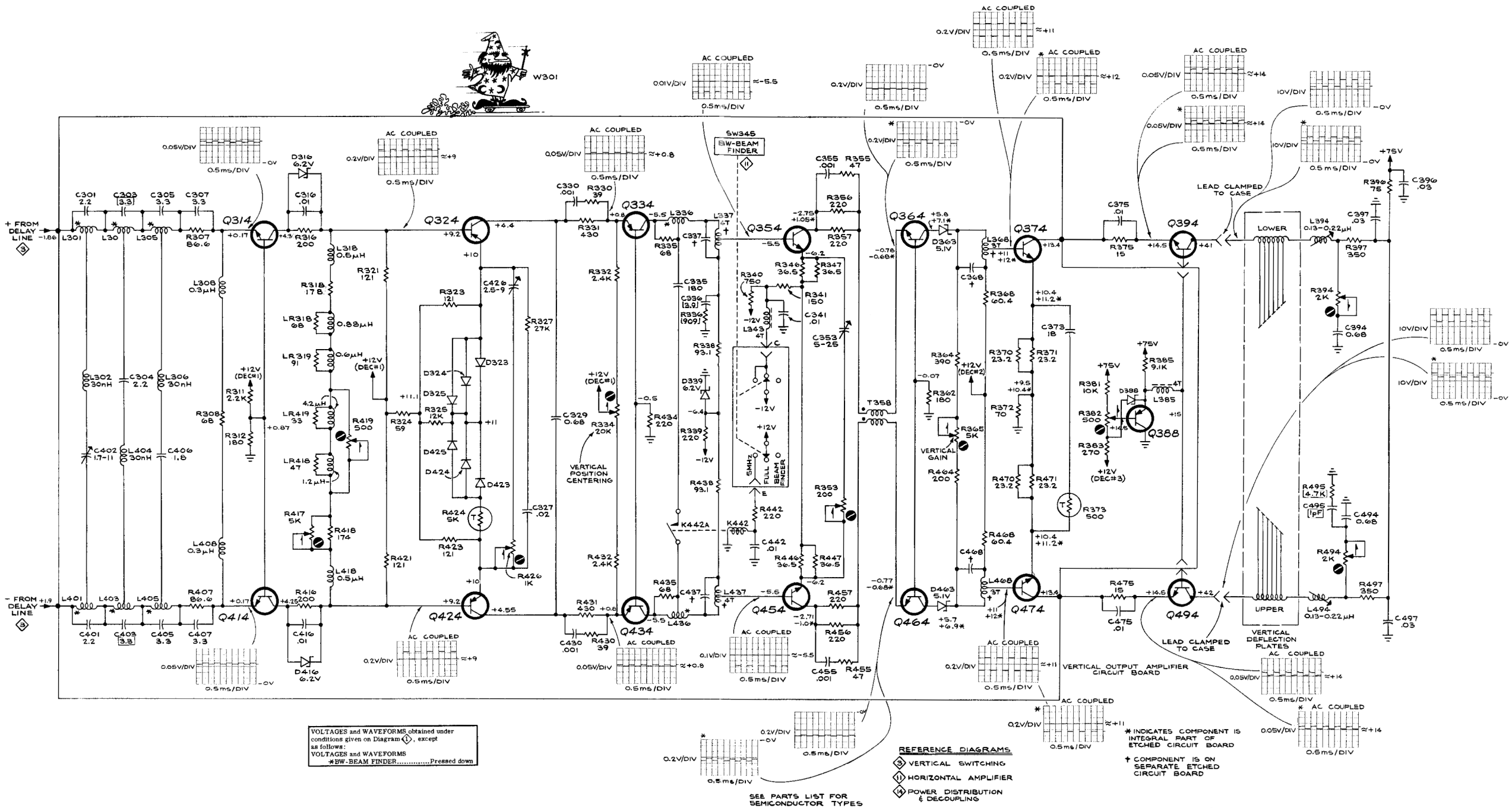

VOLTAGES and WAVEFORMS obtained under conditions given on Diagram (⊗), except as follows:
 VOLTAGES and WAVEFORMS *BW-BEAM FINDER.....Pressed down

REFERENCE DIAGRAMS

- ⊗ VERTICAL SWITCHING
- ⊕ HORIZONTAL AMPLIFIER
- ⊖ POWER DISTRIBUTION & DECOUPLING

* INDICATES COMPONENT IS INTEGRAL PART OF ETCHED CIRCUIT BOARD
 † COMPONENT IS ON SEPARATE ETCHED CIRCUIT BOARD

SEE PARTS LIST FOR SEMICONDUCTOR TYPES

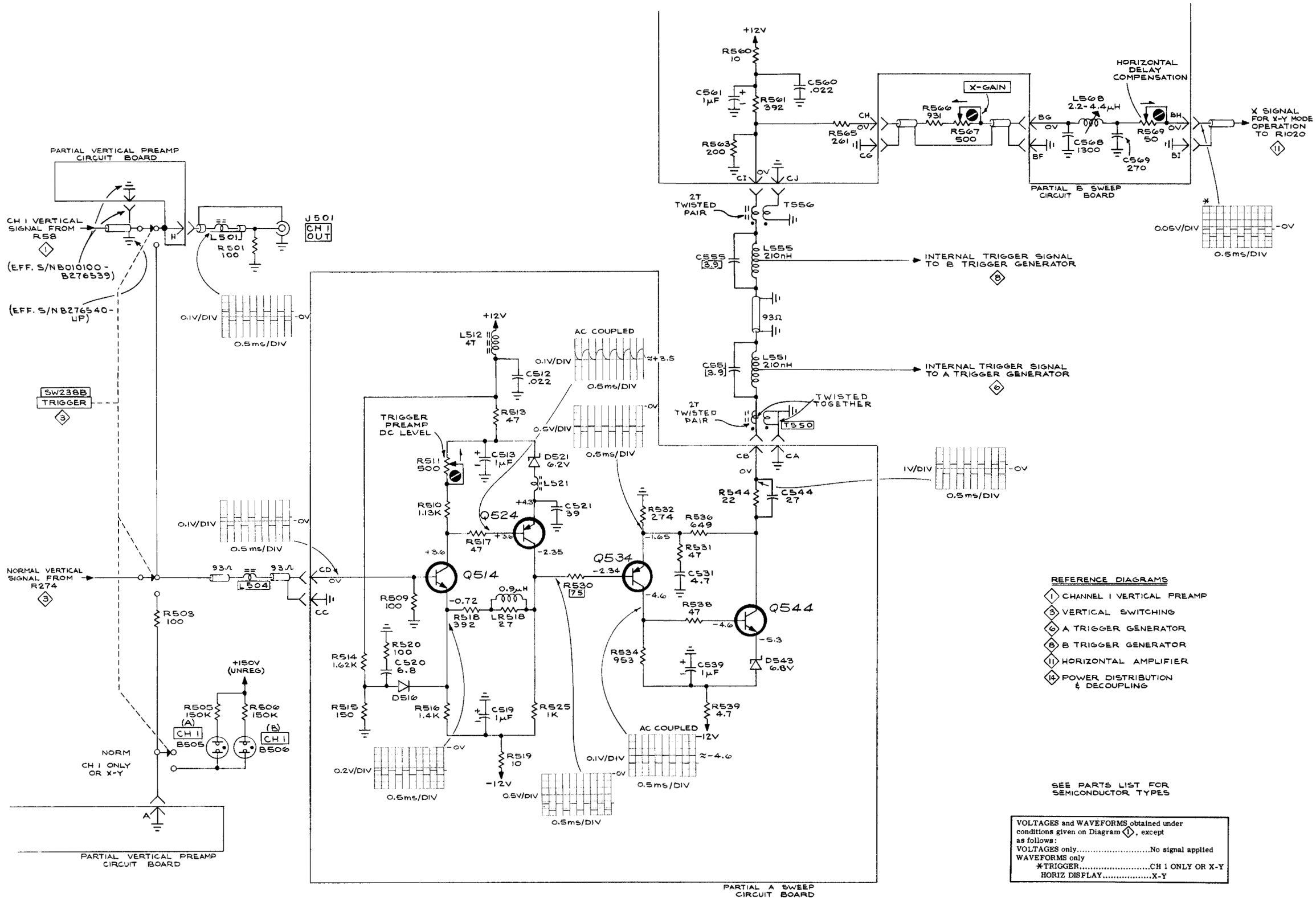

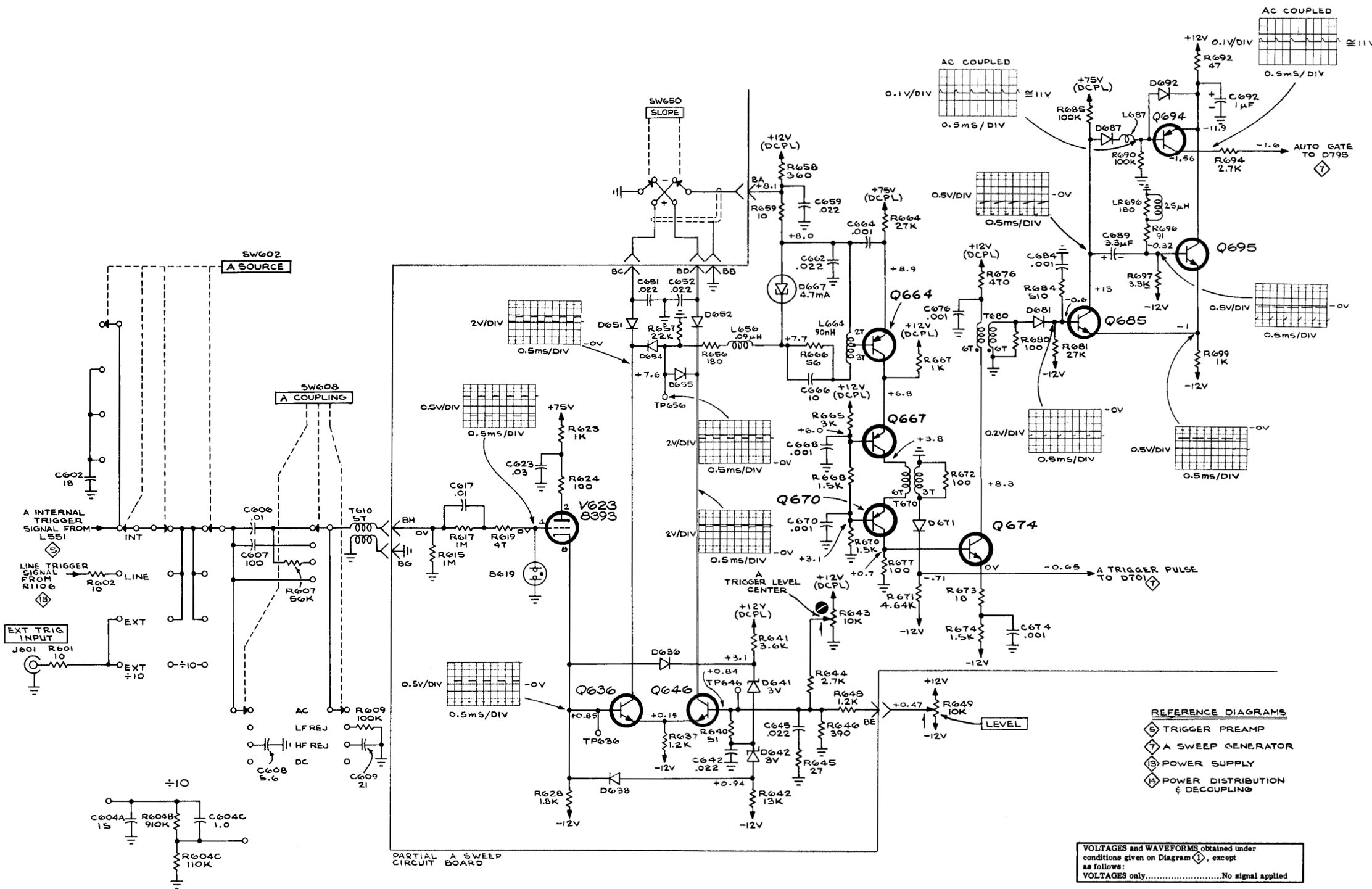

TYPE 454 OSCILLOSCOPE

(A)

6 A TRIGGER GENERATOR
S/N B 220000-UP

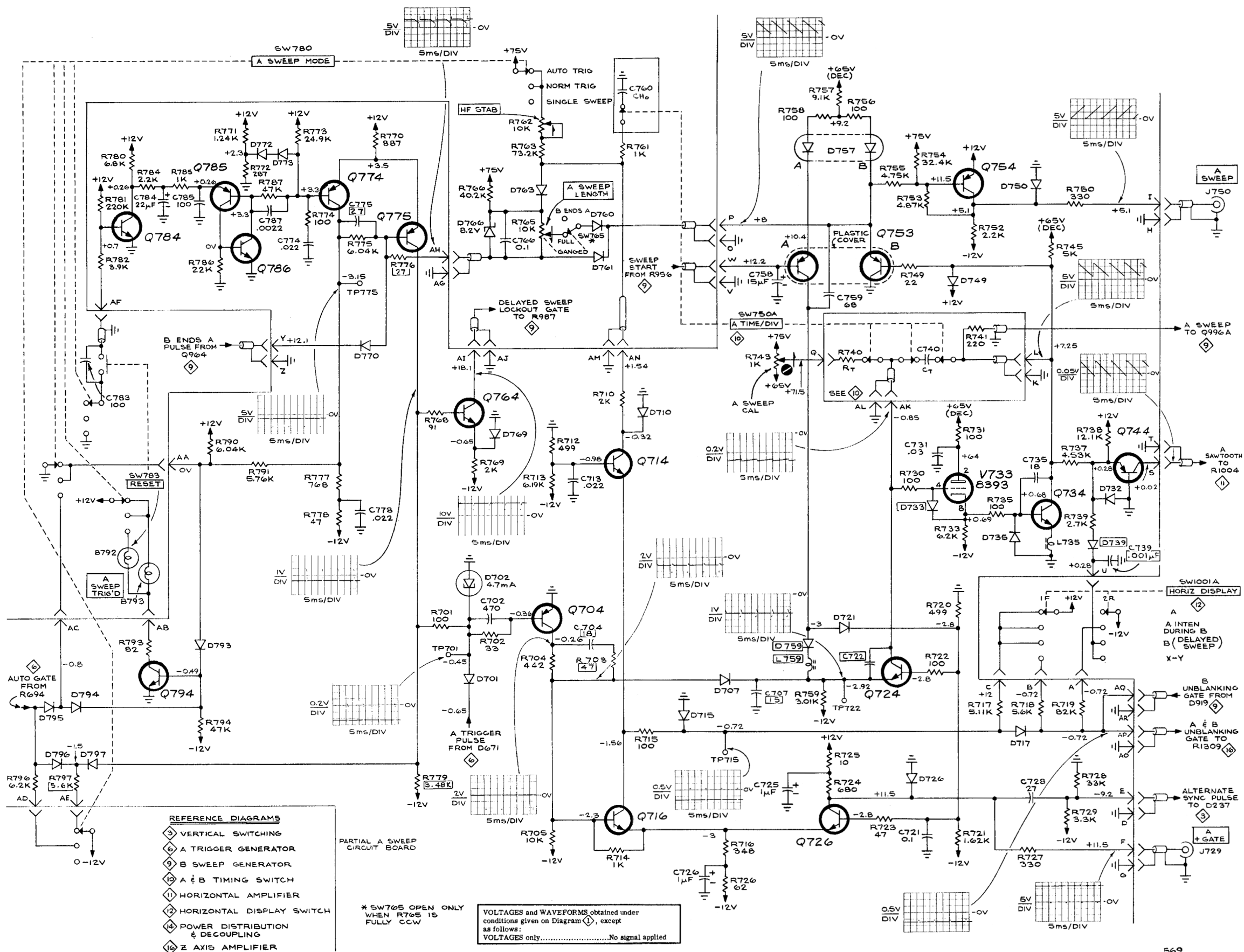

- REFERENCE DIAGRAMS**
- ③ VERTICAL SWITCHING
 - ⑥ A TRIGGER GENERATOR
 - ⑨ B SWEEP GENERATOR
 - ⑩ A & B TIMING SWITCH
 - ⑪ HORIZONTAL AMPLIFIER
 - ⑫ HORIZONTAL DISPLAY SWITCH
 - ⑬ POWER DISTRIBUTION & DECOUPLING
 - ⑭ Z AXIS AMPLIFIER

VOLTAGES and WAVEFORMS obtained under conditions given on Diagram ①, except as follows:
 VOLTAGES only.....No signal applied

* SW765 OPEN ONLY WHEN R765 IS FULLY CCW

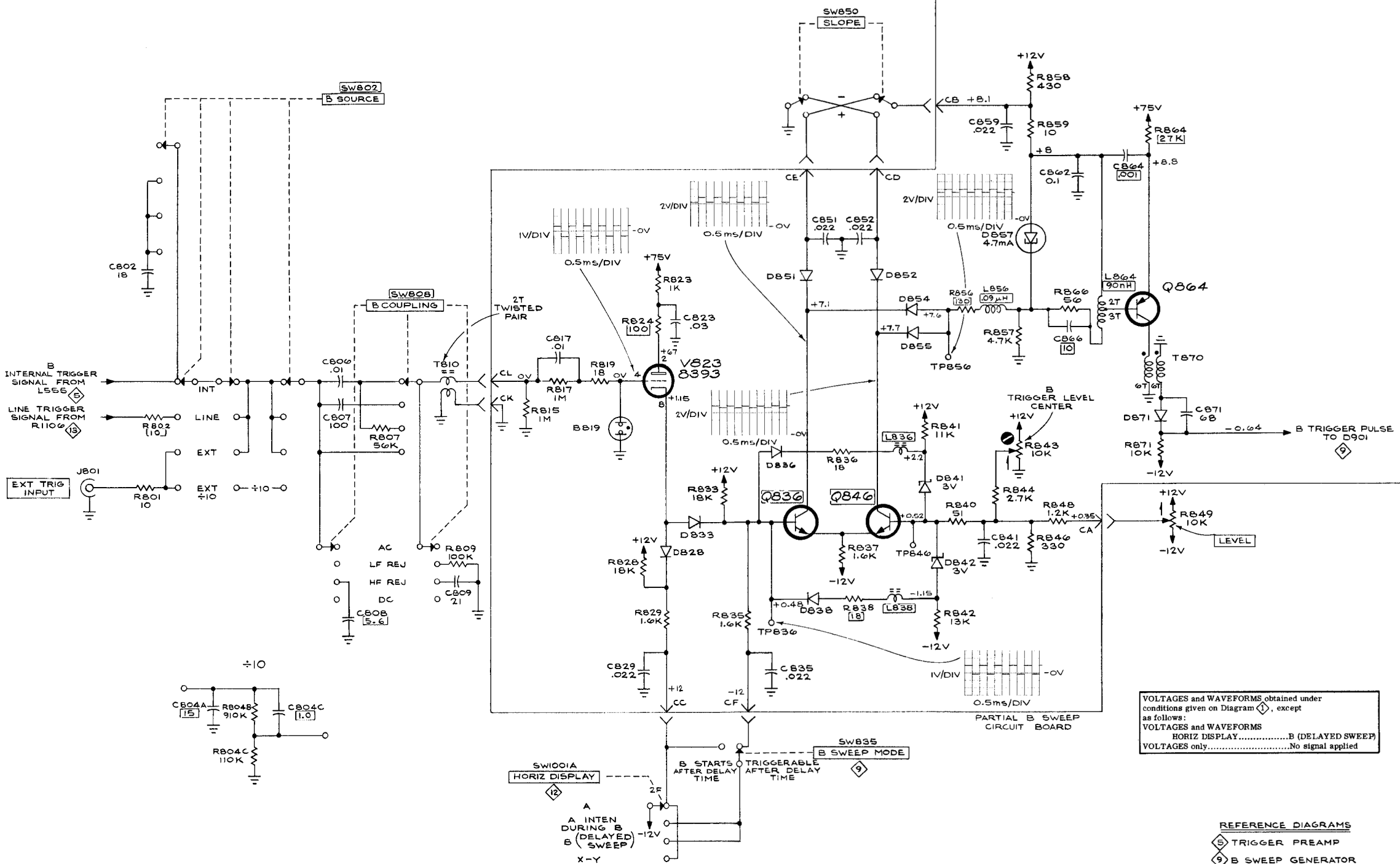

VOLTAGES and WAVEFORMS obtained under conditions given on Diagram \diamond , except as follows:
 VOLTAGES and WAVEFORMS
 HORIZ DISPLAY.....B (DELAYED SWEEP)
 VOLTAGES only.....No signal applied

REFERENCE DIAGRAMS

- \diamond 5 TRIGGER PREAMP
- \diamond 9 B SWEEP GENERATOR
- \diamond 12 HORIZONTAL DISPLAY SWITCH
- \diamond 13 POWER SUPPLY
- \diamond 14 POWER DISTRIBUTION & DECOUPLING

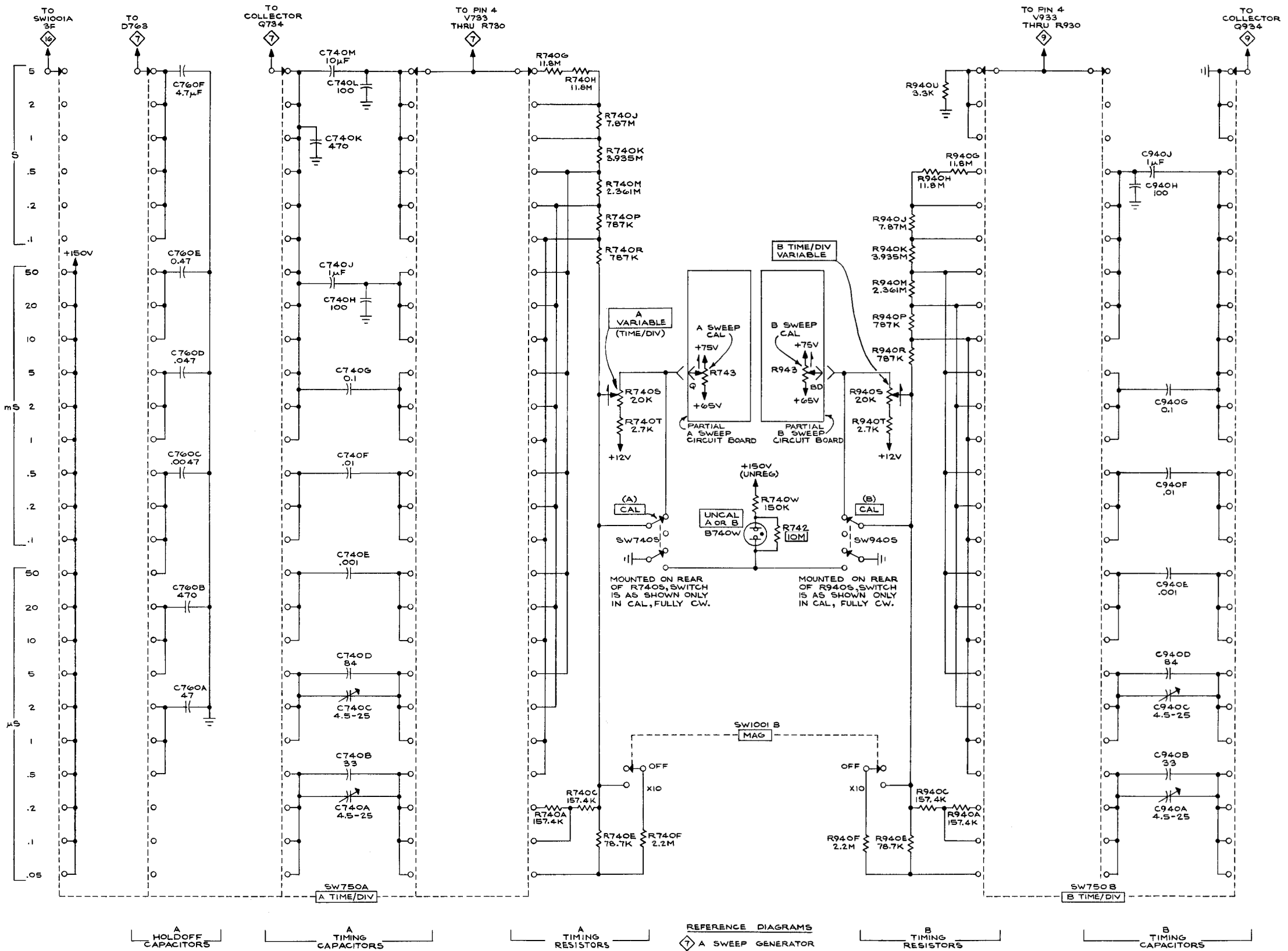

REFERENCE DIAGRAMS

- ⑦ A SWEEP GENERATOR
- ⑧ B SWEEP GENERATOR
- ⑪ HORIZONTAL AMPLIFIER
- ⑫ POWER DISTRIBUTION & DECOUPLING
- ⑬ Z AXIS AMPLIFIER

B TIMING RESISTORS

B TIMING CAPACITORS

⑩ A & B TIMING SWITCH

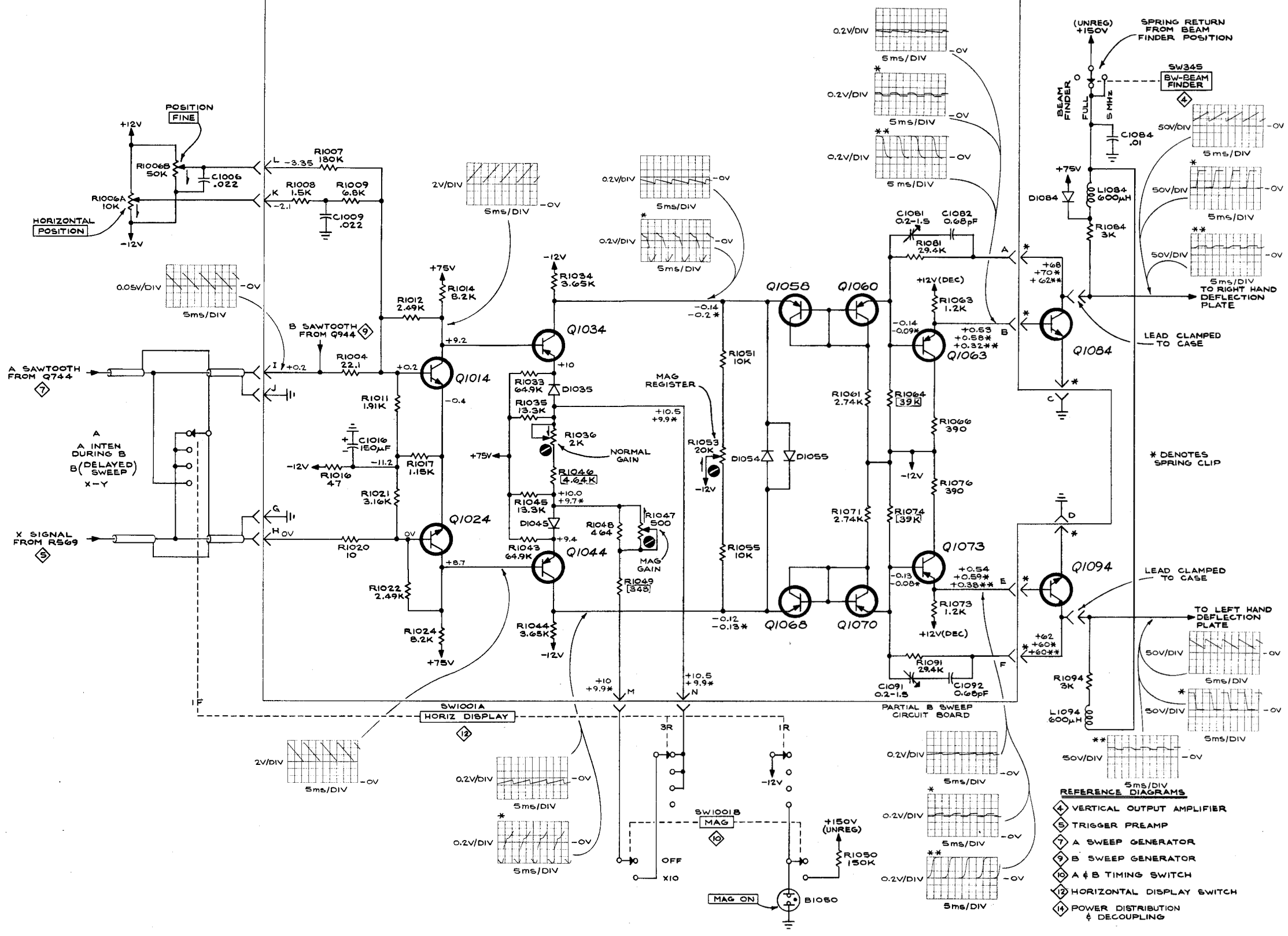

VOLTAGES and WAVEFORMS obtained under conditions given on Diagram (1), except as follows:
 VOLTAGES and WAVEFORMS
 * MAG.....X10
 * * BW-BEAM FINDER.....Pressed down
 VOLTAGES only.....No signal applied

- REFERENCE DIAGRAMS**
- (4) VERTICAL OUTPUT AMPLIFIER
 - (5) TRIGGER PREAMP
 - (7) A SWEEP GENERATOR
 - (9) B SWEEP GENERATOR
 - (10) A & B TIMING SWITCH
 - (12) HORIZONTAL DISPLAY SWITCH
 - (14) POWER DISTRIBUTION & DECOUPLING

(1) HORIZONTAL AMPLIFIER

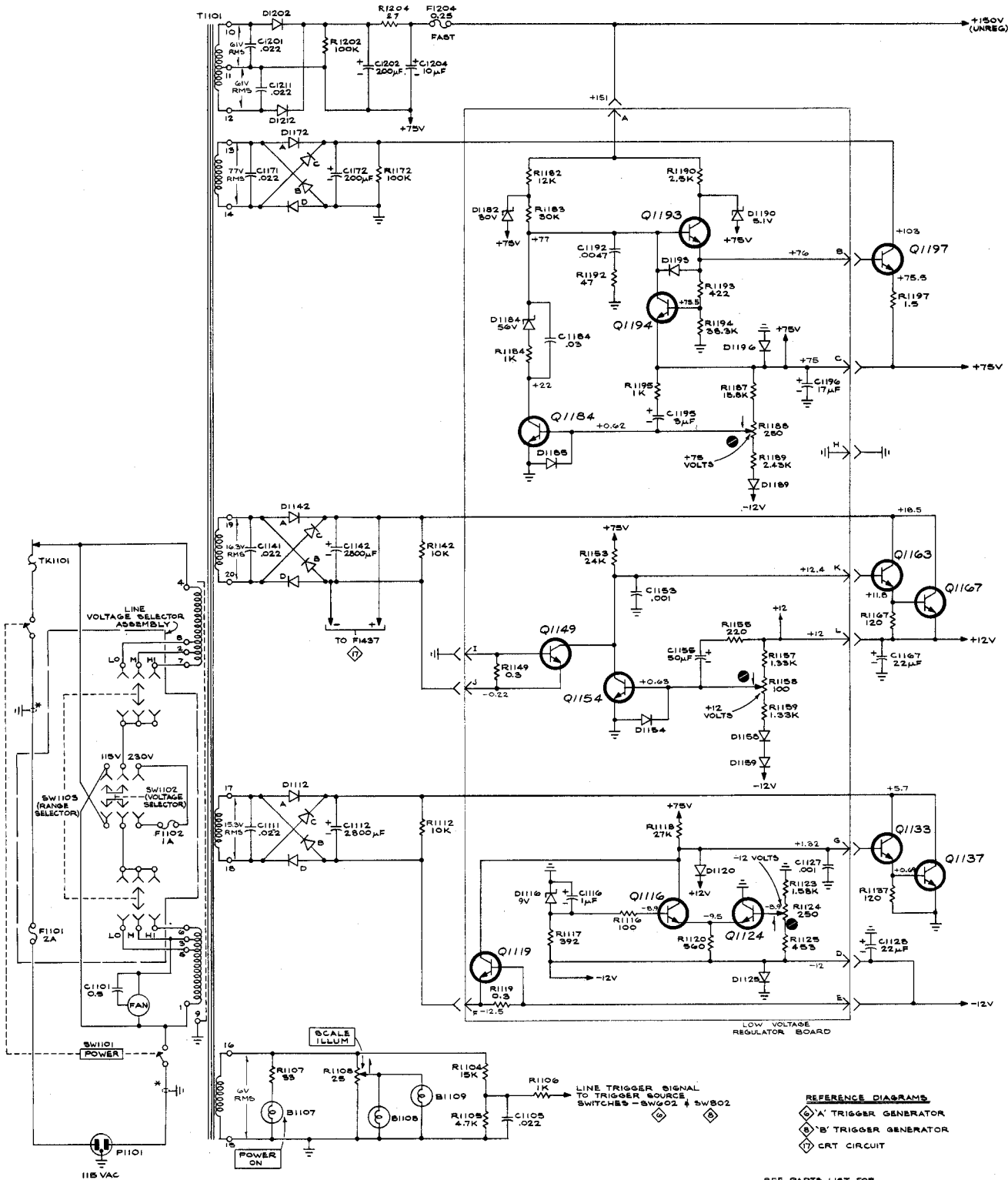

VOLTAGES obtained under conditions given on Diagram.

* SHIELD COMMON TO BOTH LEADS

SEE PARTS LIST FOR SEMICONDUCTOR TYPES

- REFERENCE DIAGRAMS
- ⊠ A' TRIGGER GENERATOR
 - ⊠ B' TRIGGER GENERATOR
 - ⊠ CRT CIRCUIT

POWER SUPPLY

TYPE 454 OSCILLOSCOPE

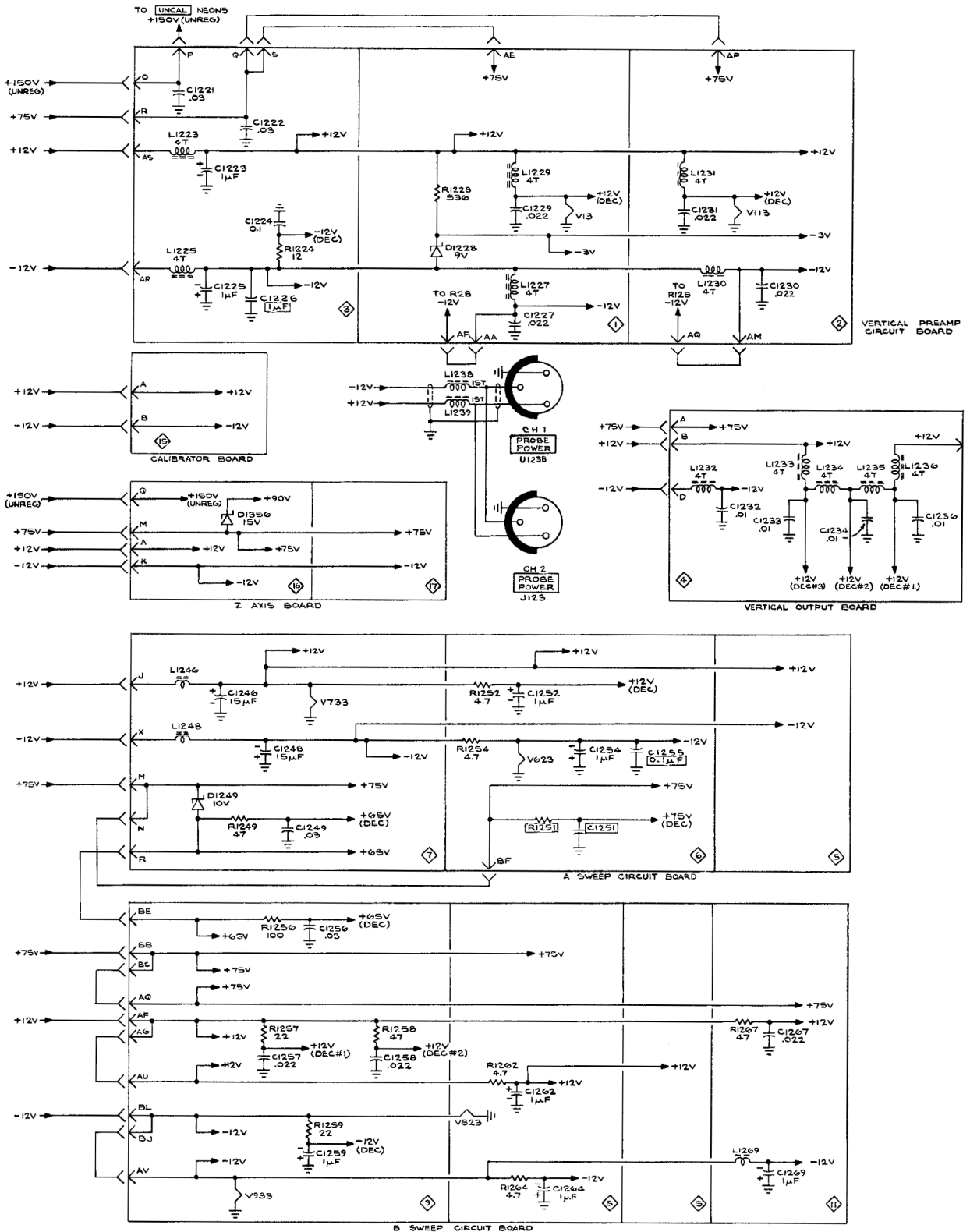

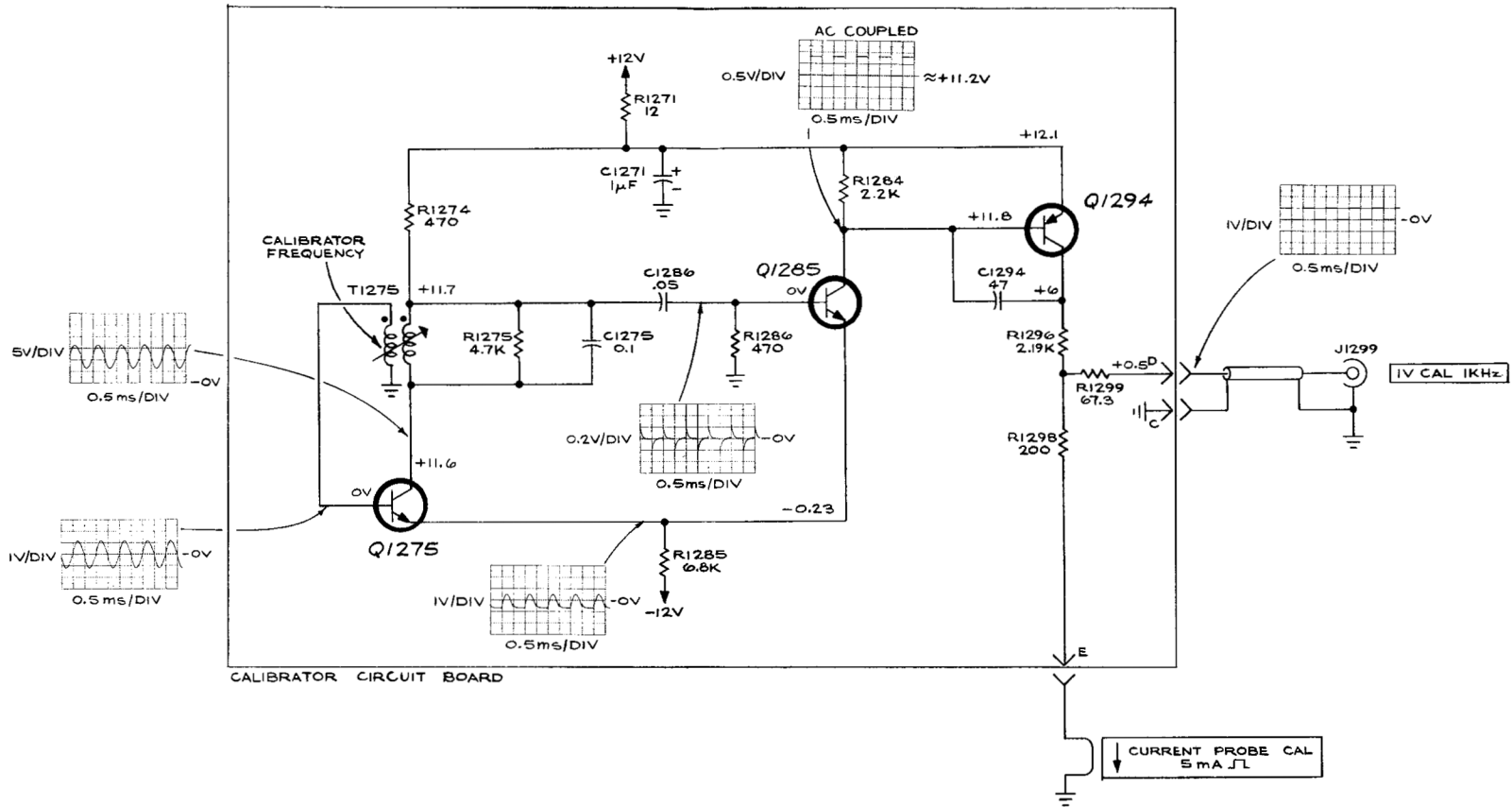

TYPE 454 OSCILLOSCOPE

A

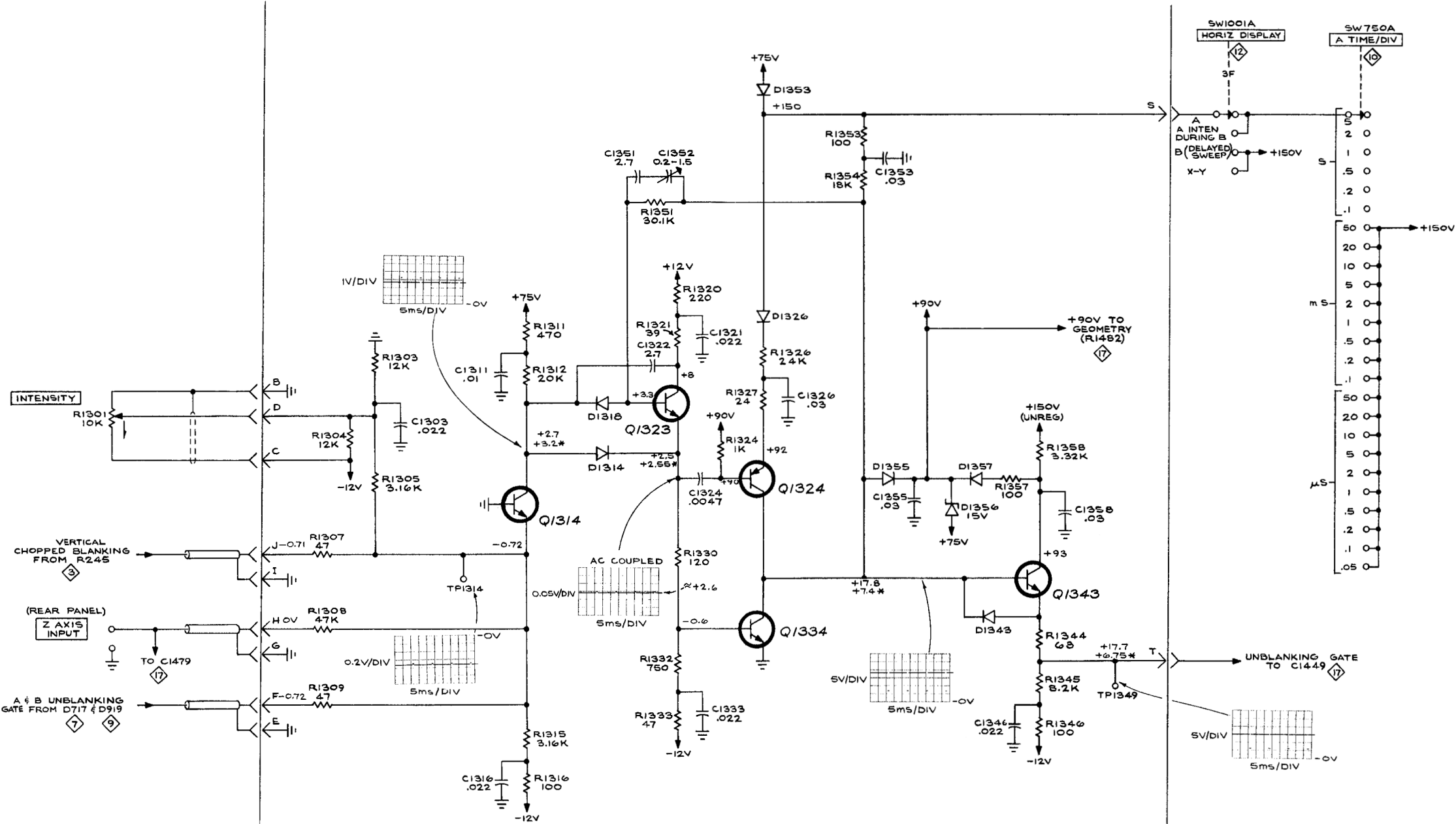

PARTIAL Z AXIS CIRCUIT BOARD

VOLTAGES and WAVEFORMS obtained under conditions given on Diagram 16, except as follows:
 VOLTAGES and WAVEFORMS
 * INTENSITY.....Fully CCW
 VOLTAGES only.....No signal applied

- REFERENCE DIAGRAM
- 3 VERTICAL SWITCHING
 - 7 A SWEEP GENERATOR
 - 9 B SWEEP GENERATOR
 - 10 A & B TIMING SWITCH
 - 12 HORIZONTAL DISPLAY SWITCH
 - 14 POWER DISTRIBUTION & DECOUPLING
 - 17 CRT CIRCUIT

FIG. 1 FRONT

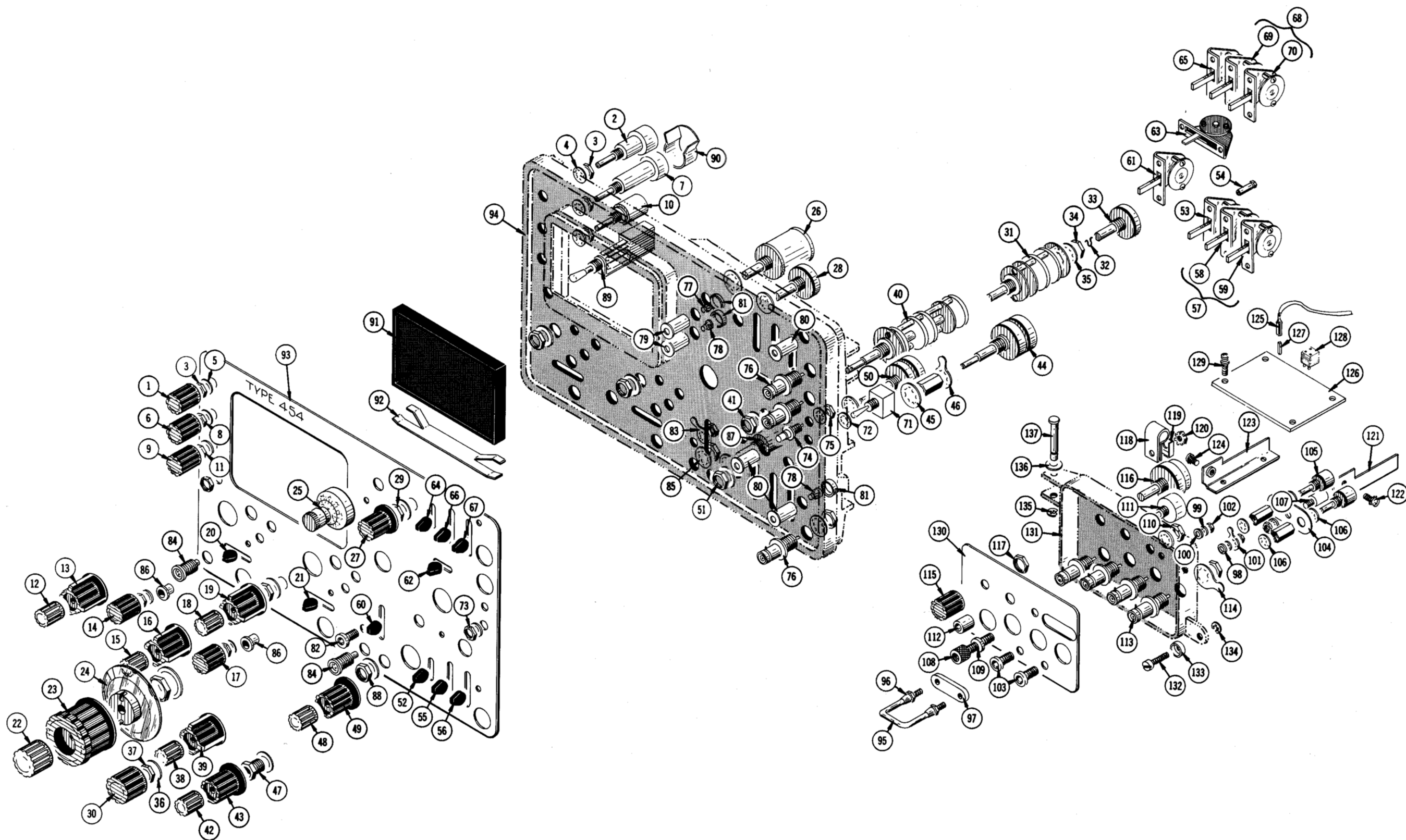
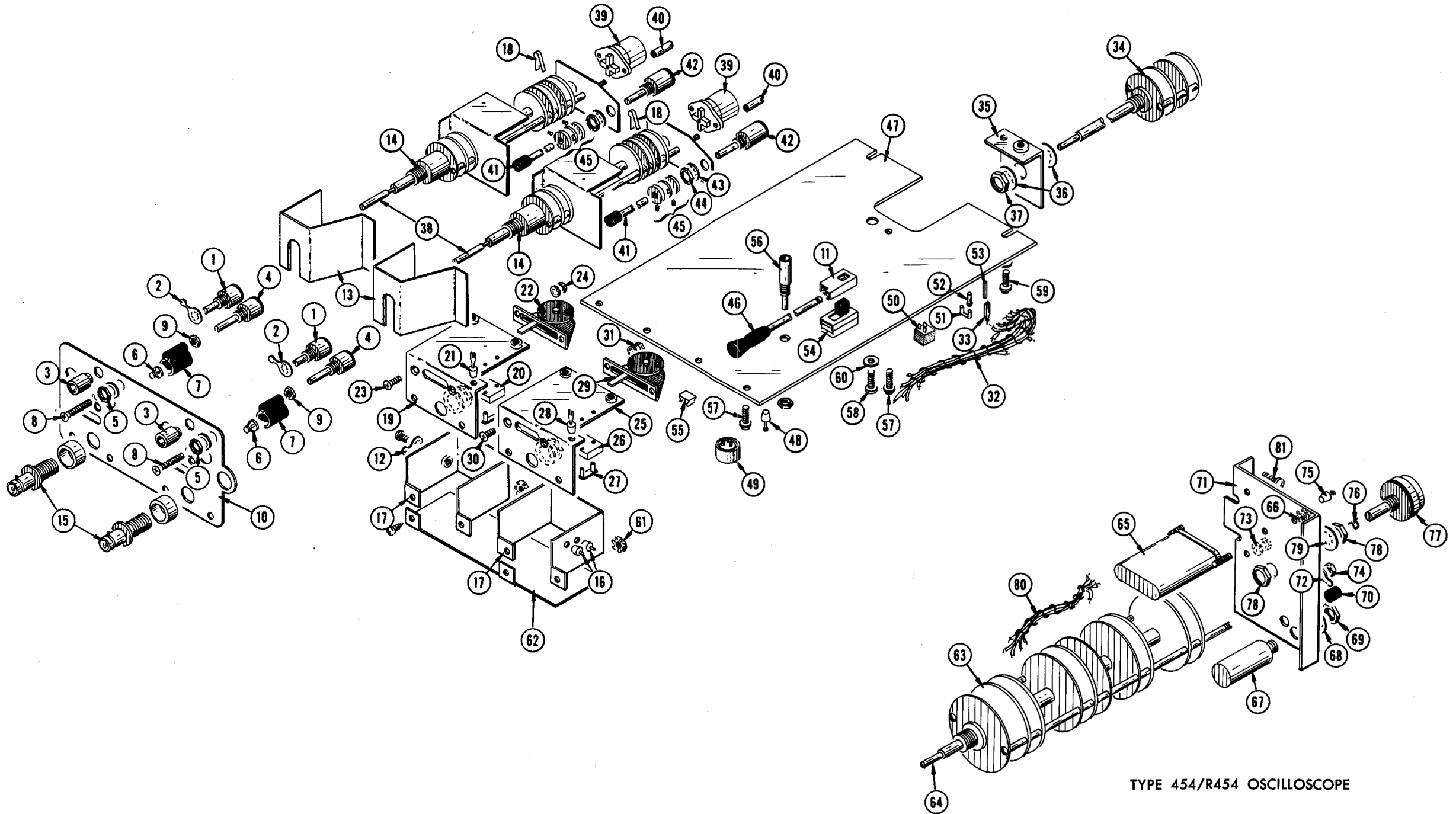
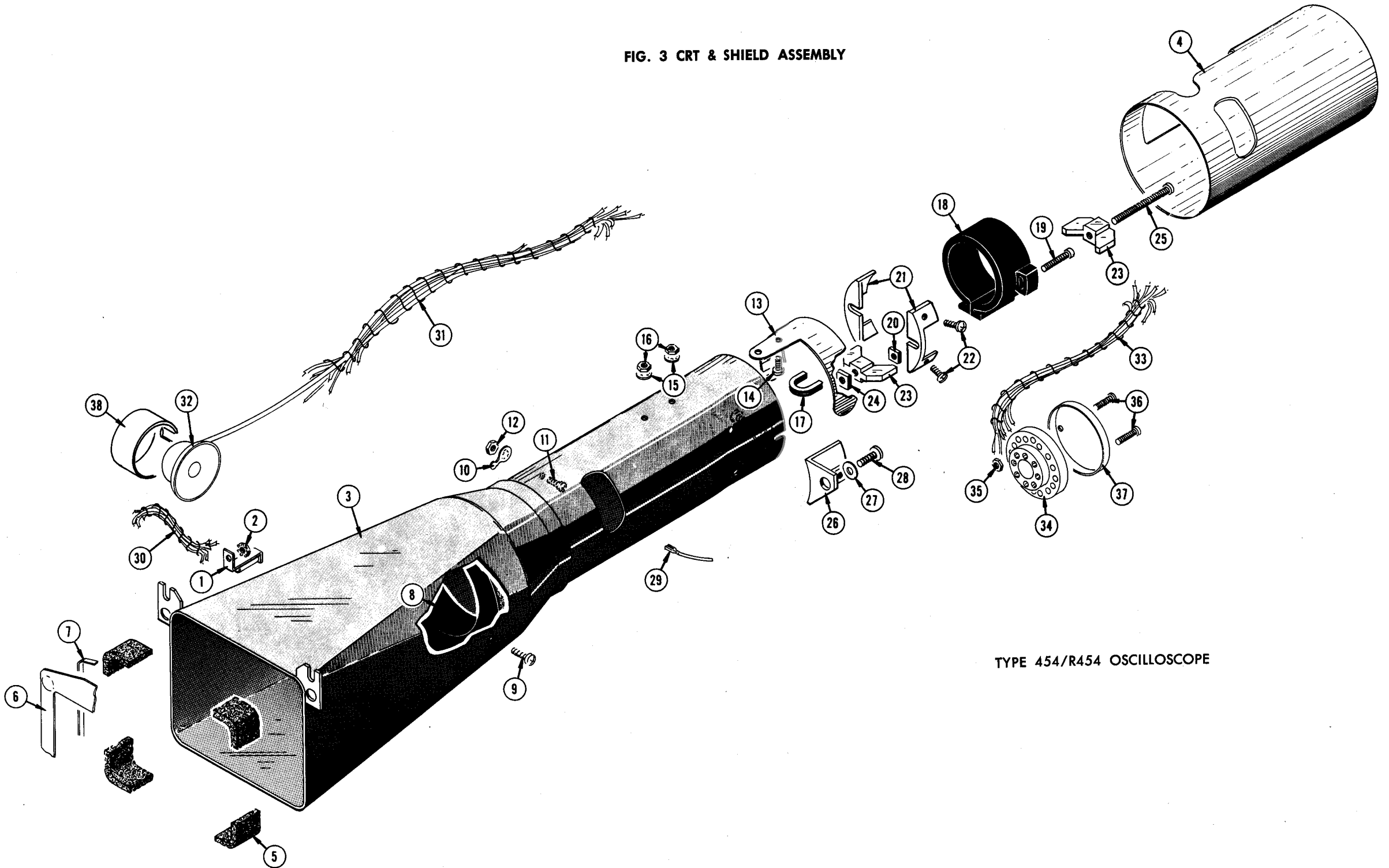

FIG. 2 ATTENUATOR ASSEMBLY & A and B TIME/DIV and DELAY TIME SWITCH



TYPE 454/R454 OSCILLOSCOPE

FIG. 3 CRT & SHIELD ASSEMBLY



TYPE 454/R454 OSCILLOSCOPE

FIG. 4 A SWEEP, B SWEEP & HIGH-VOLTAGE SUPPLY

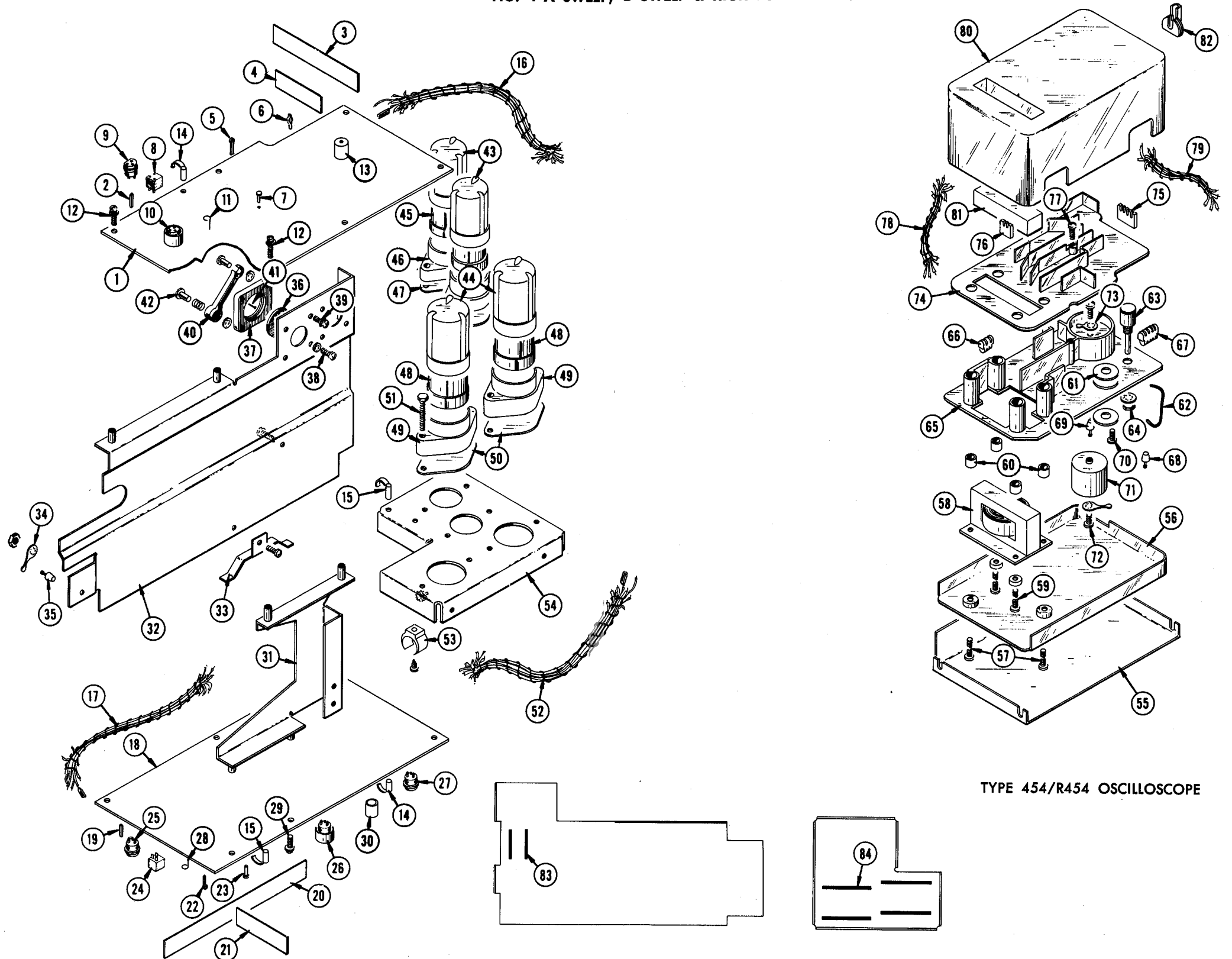

TYPE 454/R454 OSCILLOSCOPE

FIG. 5 REAR CHASSIS

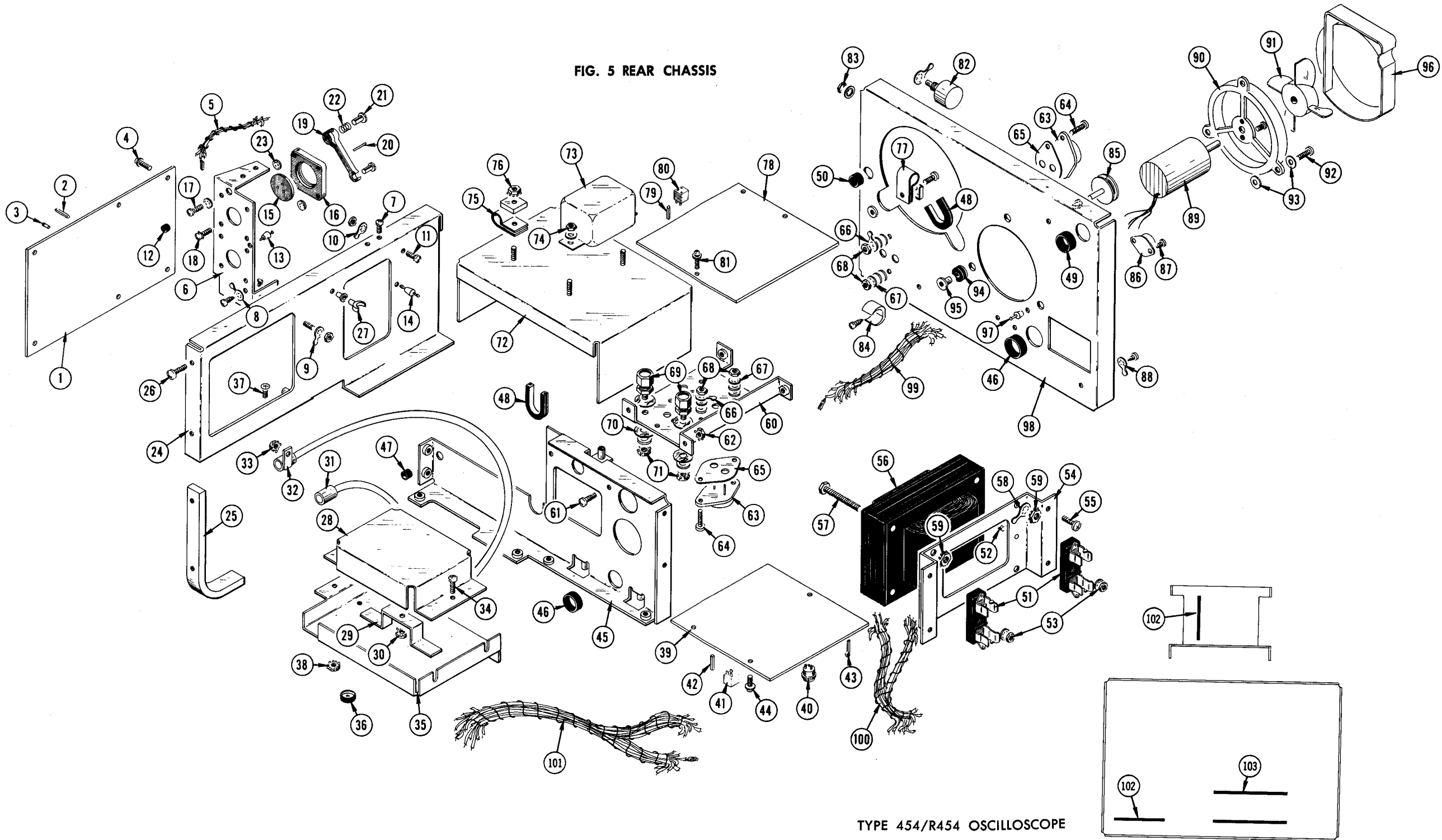

TYPE 454/R454 OSCILLOSCOPE

FIG. 7 R454 MECHANICAL PARTS

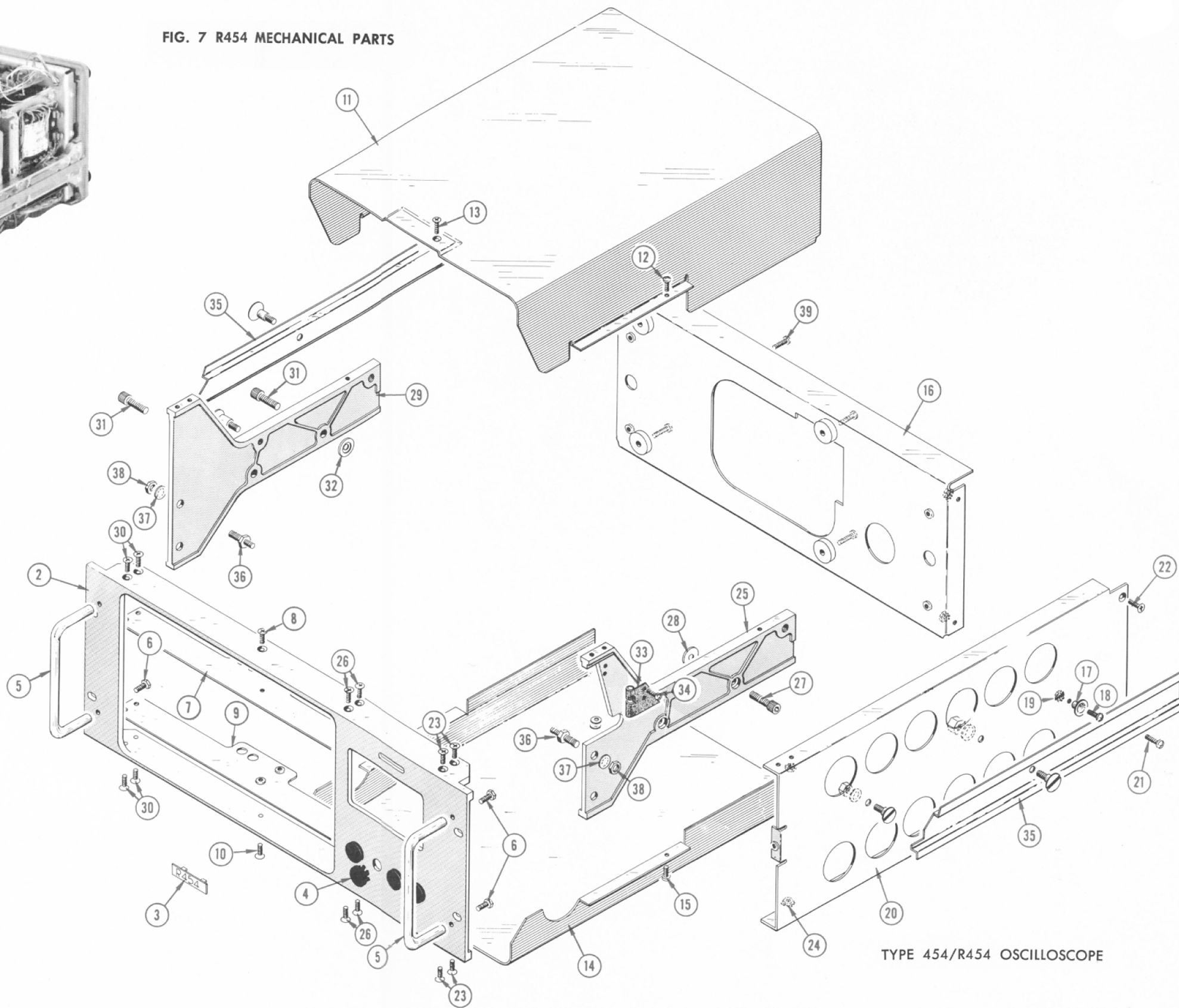
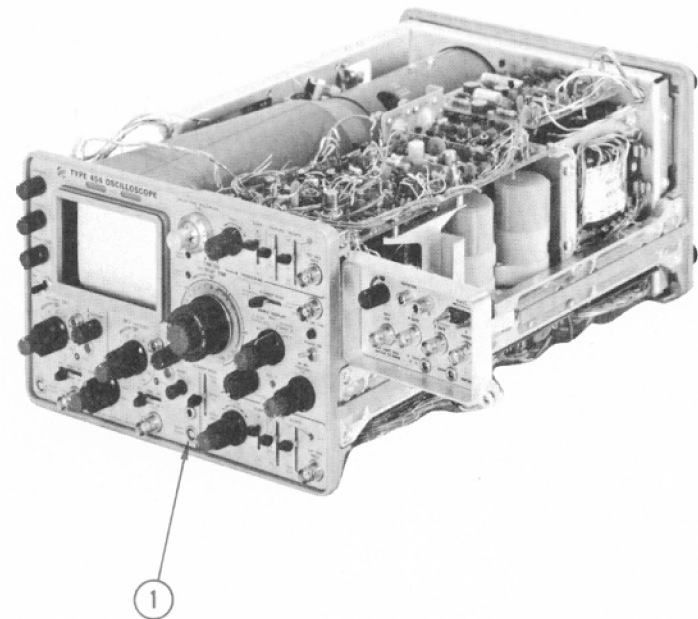

TYPE 454/R454 OSCILLOSCOPE

FIG. 8 454/R454 STANDARD ACCESSORIES

| Fig. & Index No. | Tektronix Part No. | Serial/Model No. | | Q t y | 1 2 3 4 5 | Description |
|------------------------|-----------------------|------------------|------|-------------|-----------|----------------------------------|
| | | Eff | Disc | | | |
| 8-1 | 016-0074-01 | | | 1 | | COVER, rain (TYPE 454 only) |
| -2 | 010-0211-00 | | | 2 | | PROBE PACKAGE, P6047 |
| -3 | 012-0092-00 | | | 1 | | JACK, BNC-post |
| -4 | 159-0021-00 | | | 2 | | FUSE, fast blo, 2 amp, 3AG |
| | 159-0022-00 | | | 1 | | FUSE, fast blo, 1 amp, 3AG |
| | 159-0028-00 | | | 1 | | FUSE, fast blo, 1/4 amp, 3AG |
| -5 | 103-0033-00 | | | 2 | | ADAPTER, BNC to binding post |
| -6 | 103-0013-00 | | | 1 | | ADAPTER, power cord, 3 to 2 wire |
| -7 | 012-0076-00 | | | 1 | | CABLE, BNC, 18 inches |
| -8 | 354-0269-00 | | | 1 | | RING, ornamental, CRT |
| -9 | 378-0576-00 | | | 1 | | FILTER, light, smoke gray |
| -10 | 386-0218-00 | | | 1 | | PLATE, protector, CRT |
| - - - | 070-0617-00 | | | 2 | | MANUAL, instruction (not shown) |

OTHER PARTS FURNISHED WITH R454 ONLY

| | | |
|-------------|------|--|
| 016-0096-00 | 1 | KIT, ruggedizing hardware (not shown) |
| 016-0099-00 | 1 | KIT, rackmounting hardware (not shown) |
| 351-0101-00 | 1 pr | TRACK, slide, stationary & inter-section (not shown) |

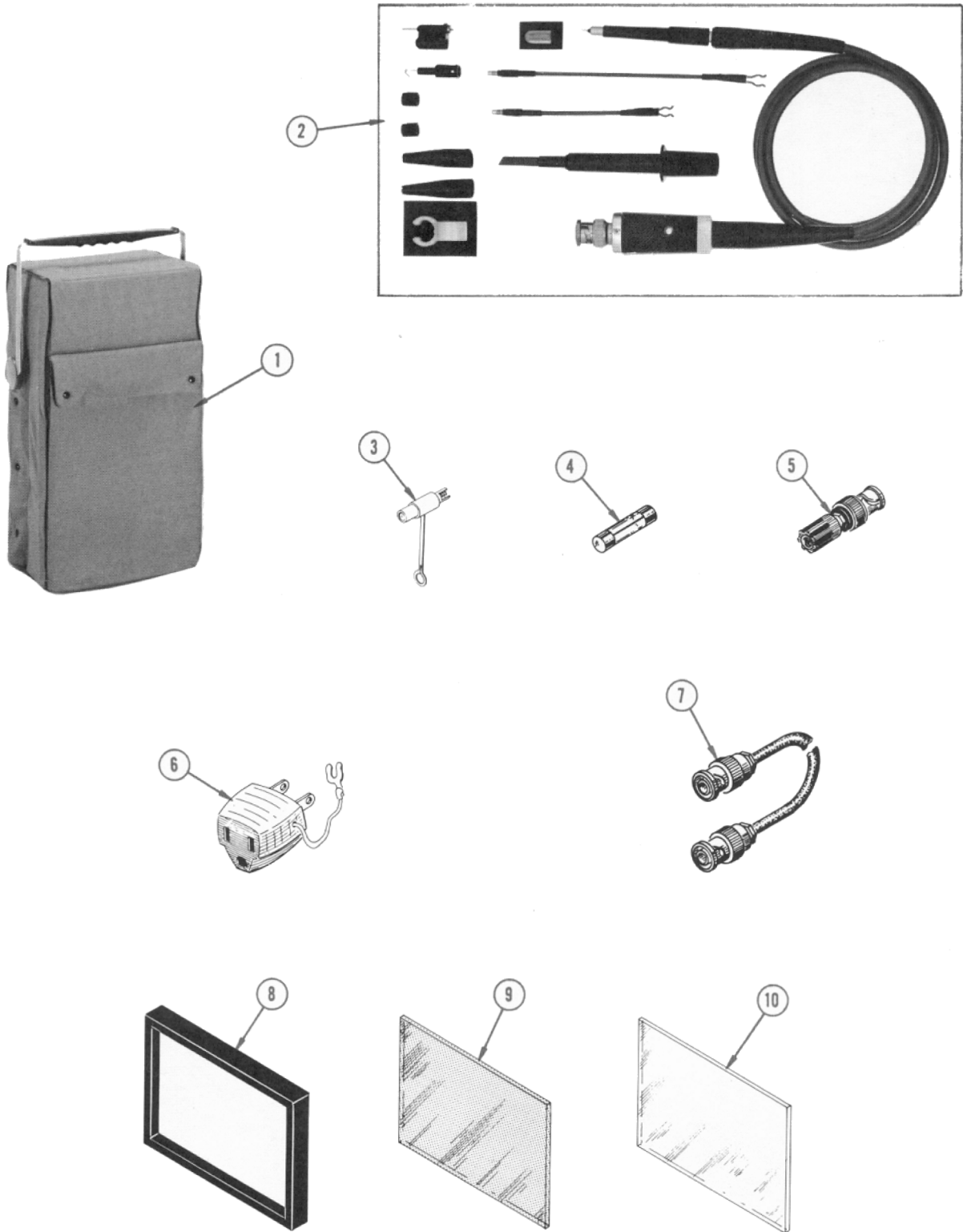

TYPE 454/R454 OSCILLOSCOPE

SECTION 10

RACK MOUNTING

Introduction

The Tektronix Type R454 Oscilloscope is designed to mount in a standard 19-inch rack. When mounted in accordance with the following mounting procedure this instrument will meet all electrical and environmental characteristics given in Section 1 of this manual.

Rack Dimensions

Height. At least seven inches of vertical space is required to mount this instrument in a cabinet rack.

Width. Minimum width of the opening between the left and right front rails of the rack must be $17\frac{5}{8}$ inches. This allows room on each side of the instrument for the slide-out tracks to operate freely, permitting the instrument to move smoothly in and out of the rack.

Depth. Total depth necessary to mount the Type R454 in a cabinet rack is $19\frac{3}{8}$ inches. This allows room for air circulation, power cord and the necessary mounting hardware.

Slide-Out Tracks

Fig. 10-1 shows the Type R454 installed in a cabinet-type rack. The slide-out tracks provided with the Type R454 permit it to be extended out of the rack for maintenance or calibration without removing the instrument from the rack. In the fully extended position, the Type R454 can be tilted up so the bottom of the instrument can be reached for maintenance or calibration. To operate the Type R454 in the extended position, be sure the power cord and any interconnecting cables are long enough for this purpose. When not extended, the instrument is held in the rack with four securing screws (see Fig. 10-1A).

The slide-out tracks consist of two assemblies—one for the left side of the instrument and one for the right side. Fig. 10-2 shows the complete slide-out track assemblies. The stationary section of each assembly attaches to the front and rear rails of the rack, and the chassis section is attached to the instrument. The intermediate section slides between the stationary and chassis sections and allows the Type R454 to be extended out of the rack. When the instrument is shipped, the stationary and intermediate sections of the tracks are packaged as matched sets and should not be separated. To identify the left or right assembly, note the position of the automatic latch (see Fig. 10-2). When mounted in the rack, the automatic latch should be at the top of both assemblies. The chassis sections are installed on the instrument at the factory.

The hardware provided for mounting the slide-out tracks is shown in Fig. 10-3. Since the hardware is intended to make the tracks compatible with a variety of cabinet racks and installation methods, not all of it will be needed for this installation. Use only the hardware that is required for the mounting method used.

Mounting Procedure

The following mounting procedure uses the rear support kit (see Fig. 10-4 and 10-7) to meet the environmental characteristics of the instrument (shock and vibration). Two alternative mounting methods are described at the end of this procedure. However, when mounted according to these alternative methods, the instrument may not meet the given environmental characteristics for shock and vibration.

The front flanges of the stationary sections may be mounted in front of (outside) or behind (inside) the front rails of the rack, depending on the type of rack. If the front rails of the rack are tapped for 10-32 screws, the front flanges are mounted outside of the rails. If the front rails of the rack are not tapped for 10-32 screws, the front flanges are mounted inside the front rail and a bar nut is used. Fig. 10-5 shows these methods of mounting the stationary sections.

The rear of the stationary sections must be firmly supported to provide a shock-mounted installation. This rear support must be located 17.471 inches, ± 0.031 inch, from the outside surface of the front rail when the mounting flange is mounted outside of the rail, or 17.531 inches, ± 0.031 inch, from the rear surface of the front rail when the mounting flange is mounted inside of the front rail. If the cabinet rack does not have a strong supporting member located the correct distance from the front rail, an additional support must be added. The instrument will not meet the environmental specifications unless firmly supported at this point. Fig. 10-4 illustrates a typical rear installation using the rear support kit and gives the necessary dimensions.

Use the following procedure to install the Type R454 in a rack:

1. Select the proper front-rail mounting holes for the stationary sections using the measurements shown in Fig. 10-4.
 - 2a. If the mounting flanges of the stationary sections are to be mounted in front of the front rails (rails tapped for 10-32 screws), mount each stationary section as shown in Fig. 10-5A.
 - 2b. If the mounting flanges of the stationary sections are to be mounted behind the front rails (rails not tapped for 10-32 screws), mount each stationary section as shown in Fig. 10-5B.
3. Attach an angle bracket to both rear rails of the rack through the spacer block, stationary section and into the rear rail of the rack. Note that the holes in the spacer block are not centered. Be sure to mount the block with the narrow edge toward the front of the rack; otherwise, the instrument may not slide all the way into the rack. Do not tighten the mounting screws. Fig. 10-7 shows the parts in the rear support kit and the order in which they are assembled.

4. Assemble the support pin to the angle bracket in the order shown in Fig. 10-7. Leave the spacer (washer) off, but install the neoprene washer.

5. Install a support block on each side of the instrument as shown in Fig. 10-8.

6. Refer to Fig. 10-9 to insert the instrument into the rack. Do not connect the power cord or install the securing screws until all adjustments have been made.

7. With the instrument pushed all the way into the rack, adjust the angle bracket so the neoprene washers on the support pins are seated firmly against the rear of the instrument and the support pins are correctly positioned in the support block on the rear of the instrument. Tighten all screws.

8. Pull the instrument partially out of the rack.

9. Remove the neoprene washers from the support pins and place the spacers on the pins. Replace the neoprene washers.

10. Position the instrument so the pivot screws (widest part of instrument) are approximately even with the front rails.

11. Adjust the alignment of the stationary sections according to the procedure outlined in Fig. 10-10. (If the rear alignment is changed, recheck the rear support pins for correct alignment.)

12. After the tracks operate smoothly, connect the power cord to the power source.

13. Push the instrument all the way into the rack and secure it to the rack with the securing screws and washers as shown in Fig. 10-9C.

NOTE

The securing screws are an important part of the shock-mounted installation. If the front rails are not tapped for the 10-32 securing screws, other means must be provided for securing the instrument to the rack.

Alternative Rear Mounting Methods

CAUTION

Although the following methods provide satisfactory mounting under normal conditions, they do not provide solid support at the rear of the instrument. If the instrument is subjected to severe shock or vibration when mounted using the following methods, it may be damaged.

An alternative method of supporting the rear of the instrument is shown in Fig. 10-11. The rear support brackets supplied with the instrument allow it to be mounted in a rack which has a spacing between the front and rear rails of 11 to 24 inches. Fig. 10-11A illustrates the mounting method if the rear rail are tapped for 10-32 screws, and Fig 10-11B illustrates the mounting method if the rear rails are not tapped for 10-32 screws. The rear support kit is not used for this installation.

If the rack does not have a rear rail, or if the distance between the front and rear rails is too large, the instrument may be mounted without the use of the slide-out tracks. Fasten the instrument to the front rails of the rack with the securing screws and washers. This mounting method should be used only if the instrument will not be subjected to shock or vibration and if it is installed in a stationary location.

Removing or Installing the Instrument

After initial installation and adjustment of the slide-out tracks, the Type R454 can be removed or installed by following the instructions given in Fig. 10-9. No further adjustments are required under normal conditions.

Slide-Out Track Lubrication

The slide-out tracks normally require no lubrication. The special finish on the sliding surfaces provides permanent lubrication. However, if the tracks do not slide smoothly even after proper adjustment, a thin coating of paraffin rubbed onto the sliding surfaces may improve operation.

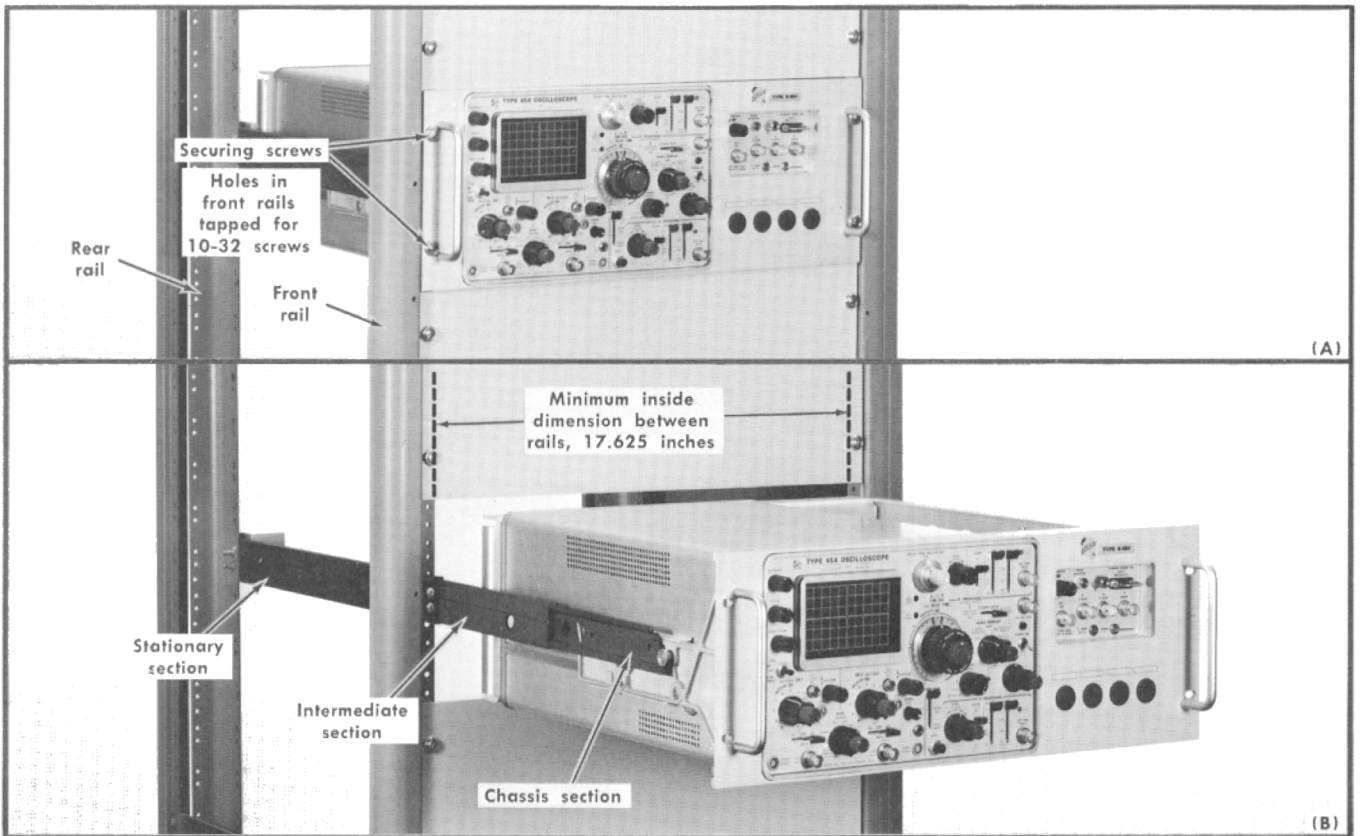

Fig. 10-1. The Type R454 installed in a cabinet rack (sides removed): (A) held into rack with securing screws, (B) extended on slideout tracks.

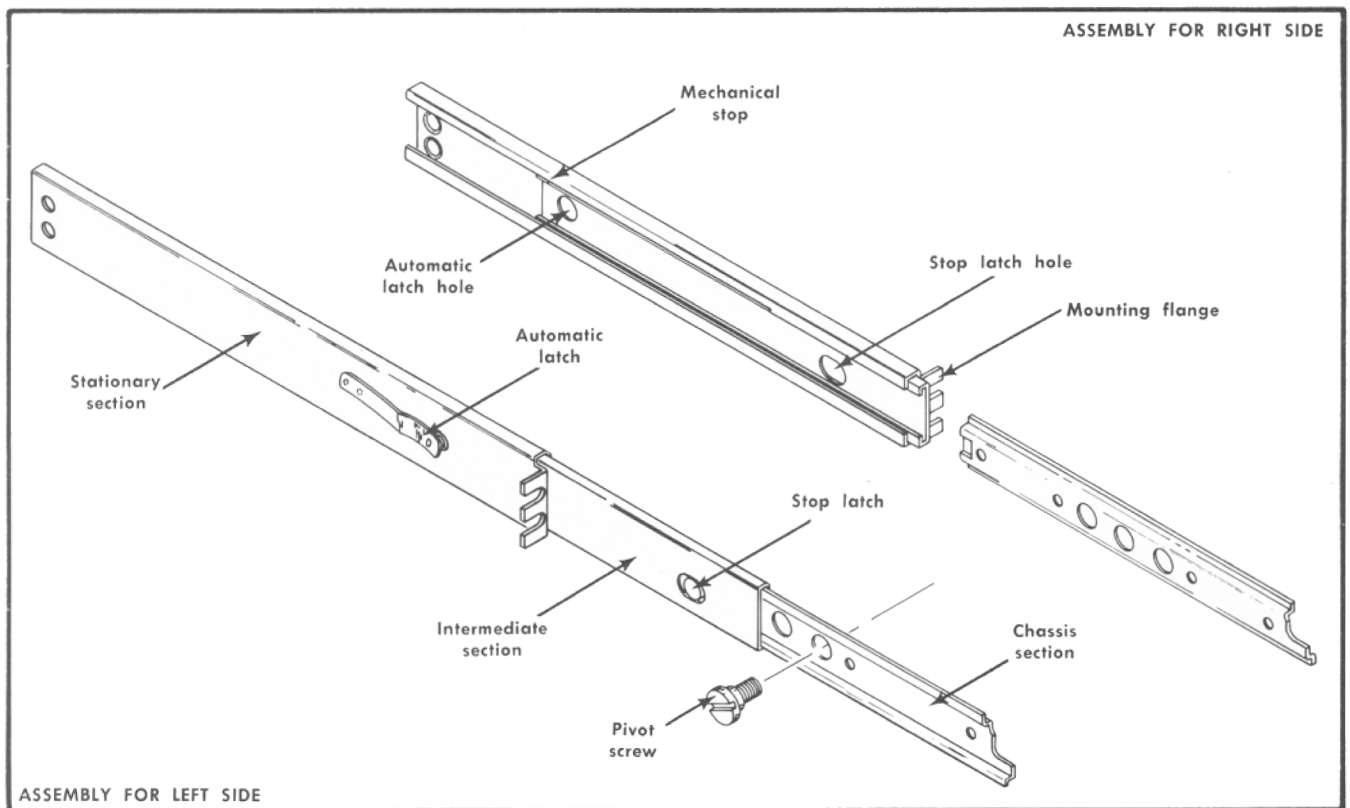

Fig. 10-2. Slideout track assemblies.

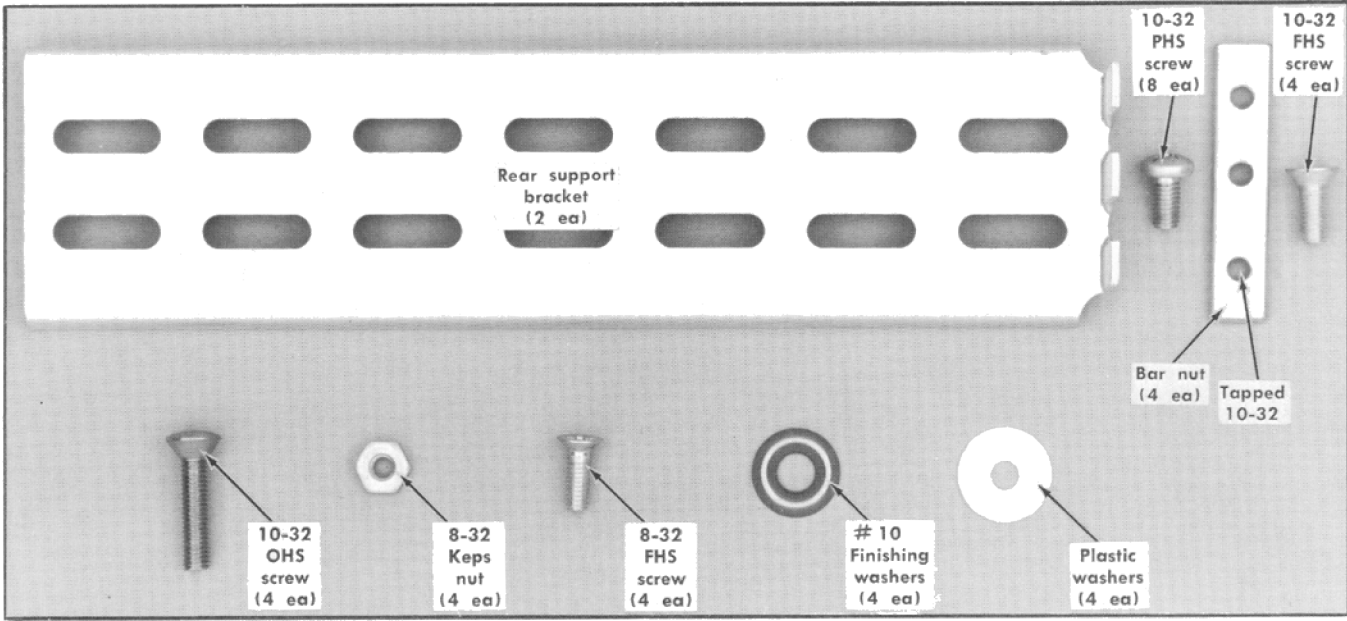

Fig. 10-3. Hardware needed to mount the instrument in the cabinet rack.

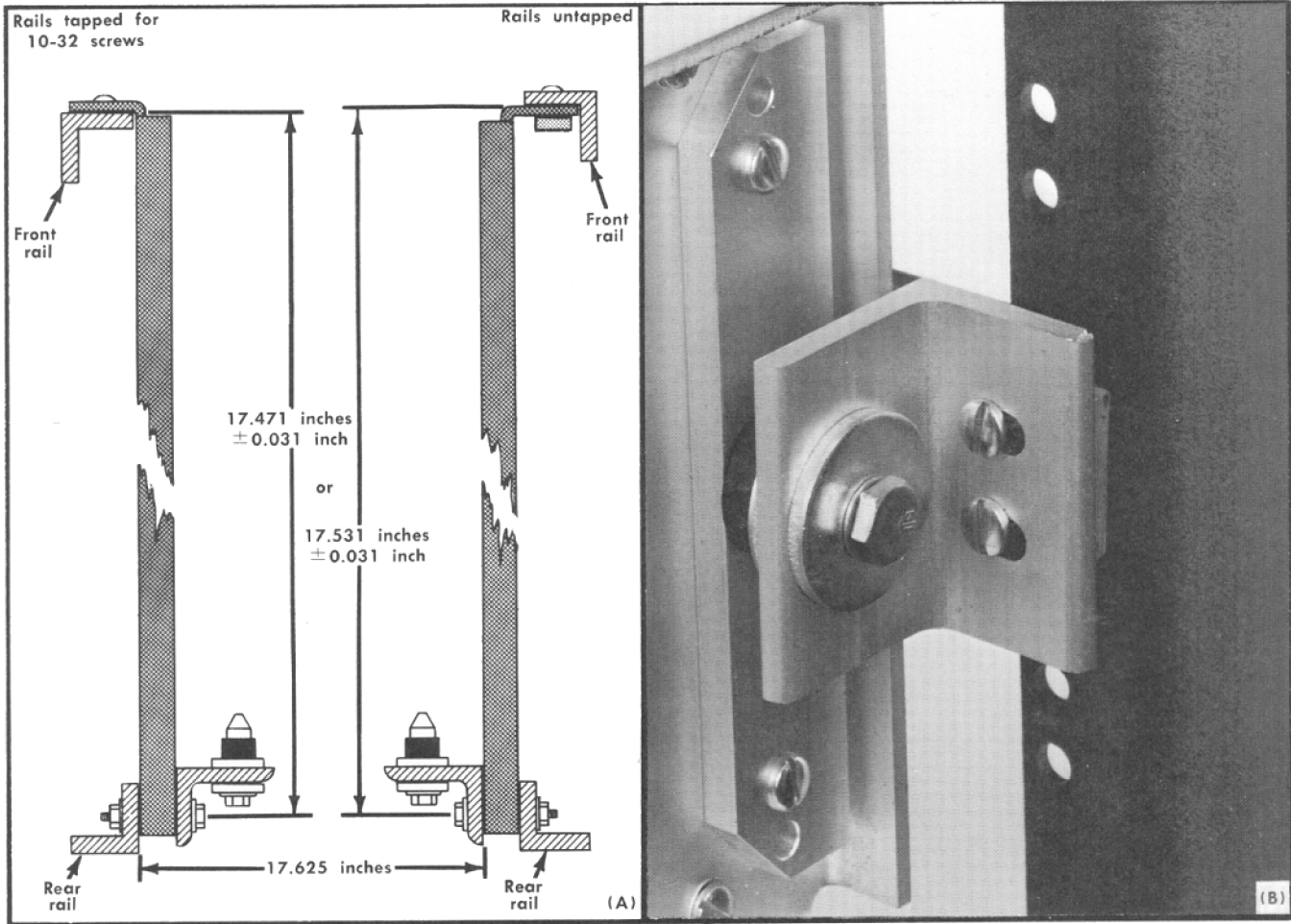

Fig. 10-4. Supporting the rear of the stationary sections: (A) dimensions necessary, (B) completed installation.

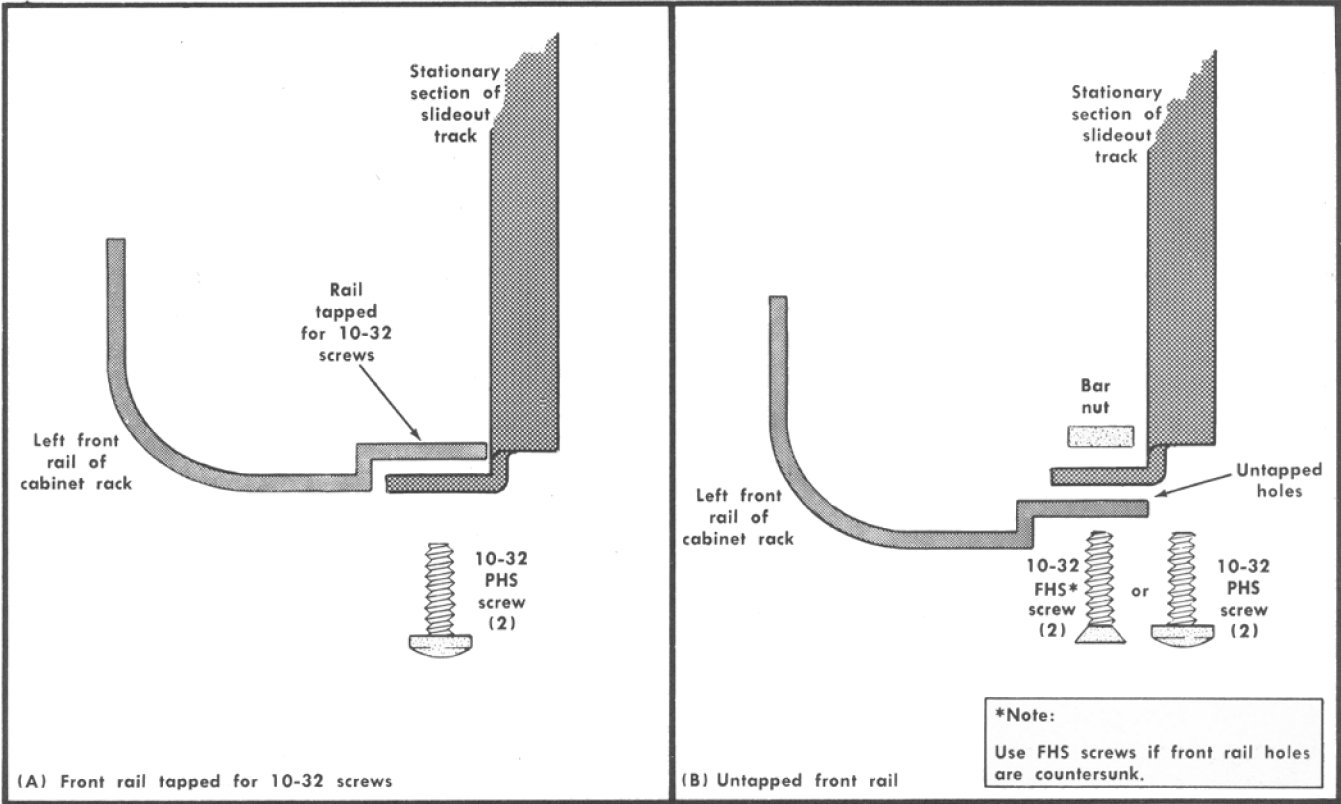

Fig. 10-5. Methods of mounting the stationary section to the front rails.

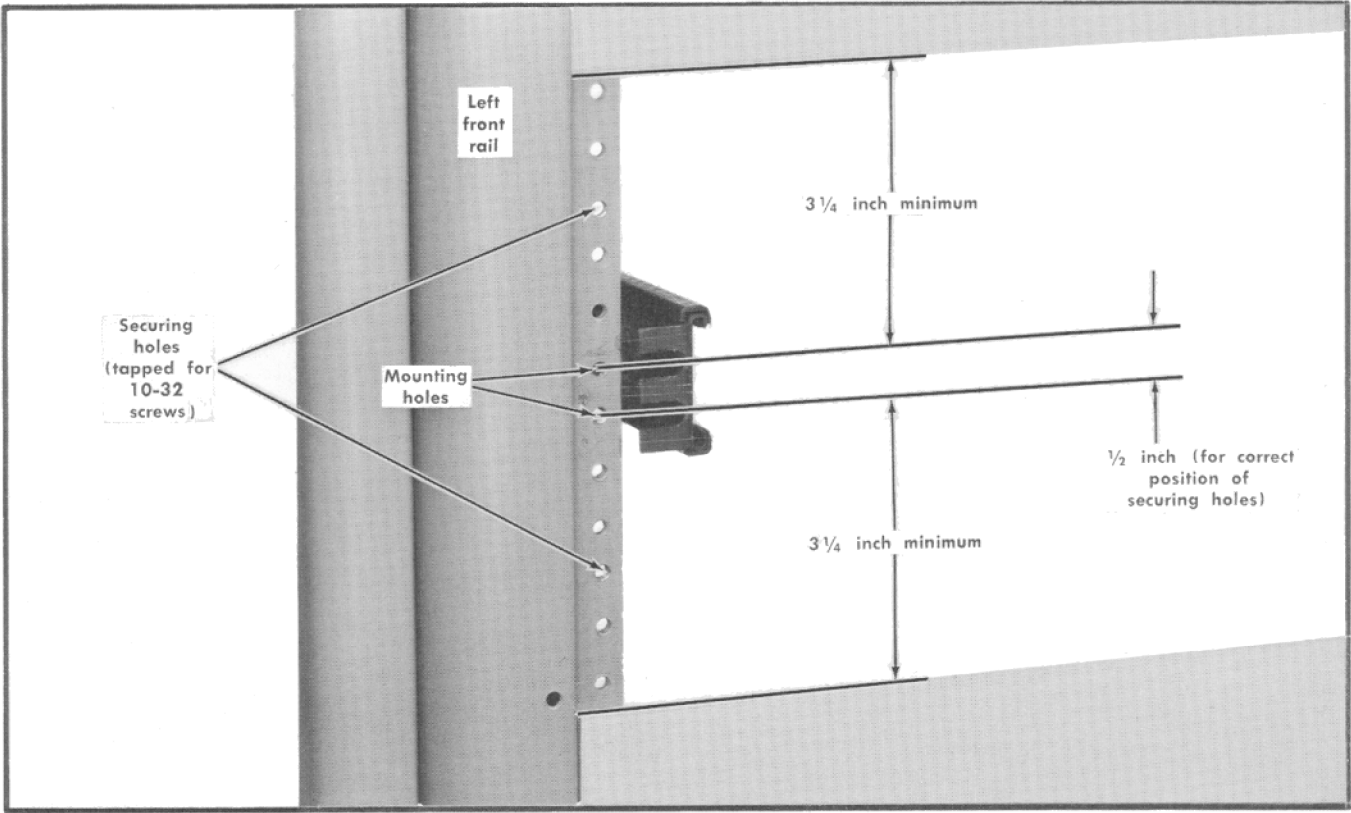

Fig. 10-6. Locating the mounting holes for the stationary section. Same dimensions apply to right stationary section.

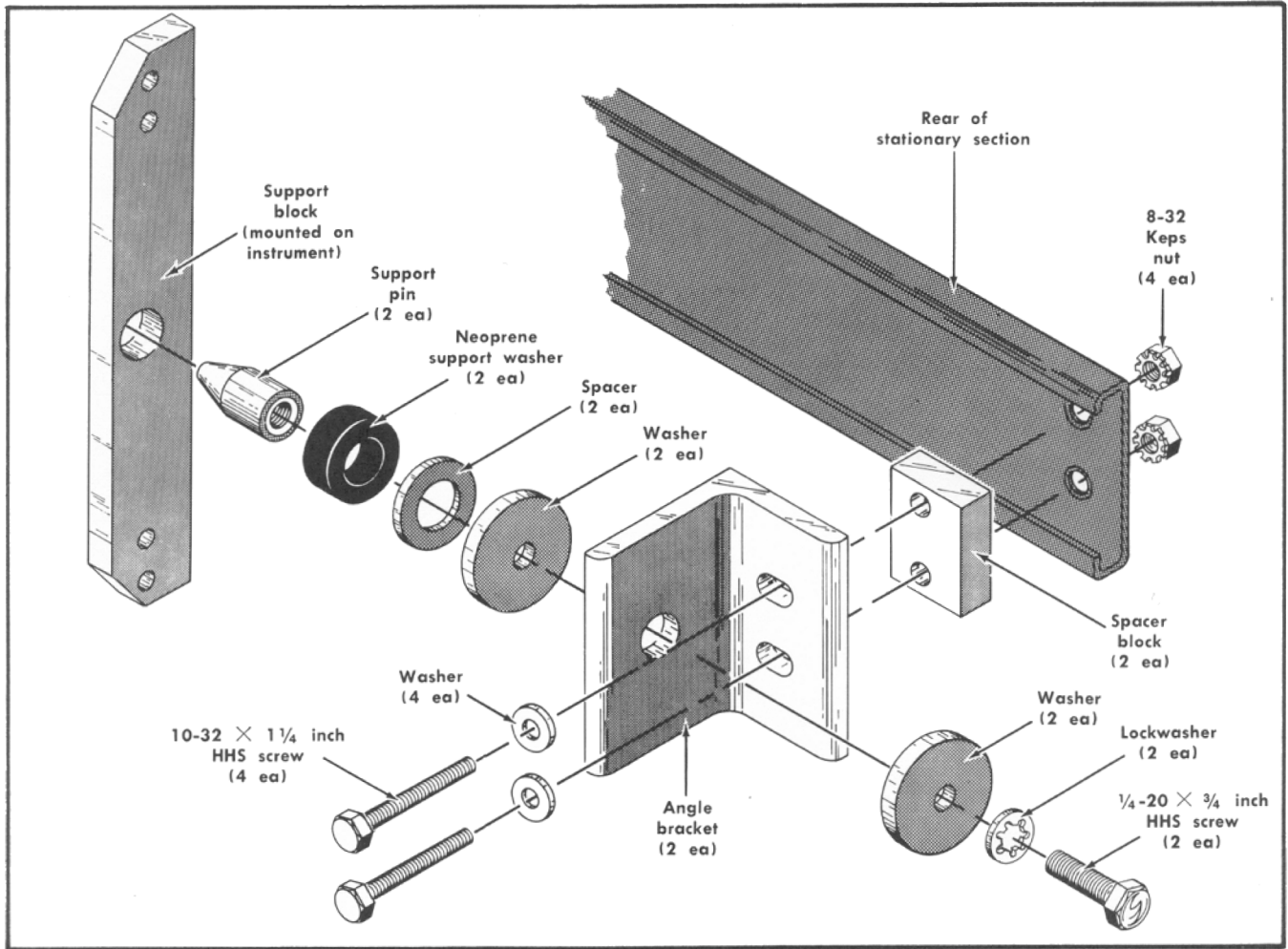

Fig. 10-7. Rear support kit.

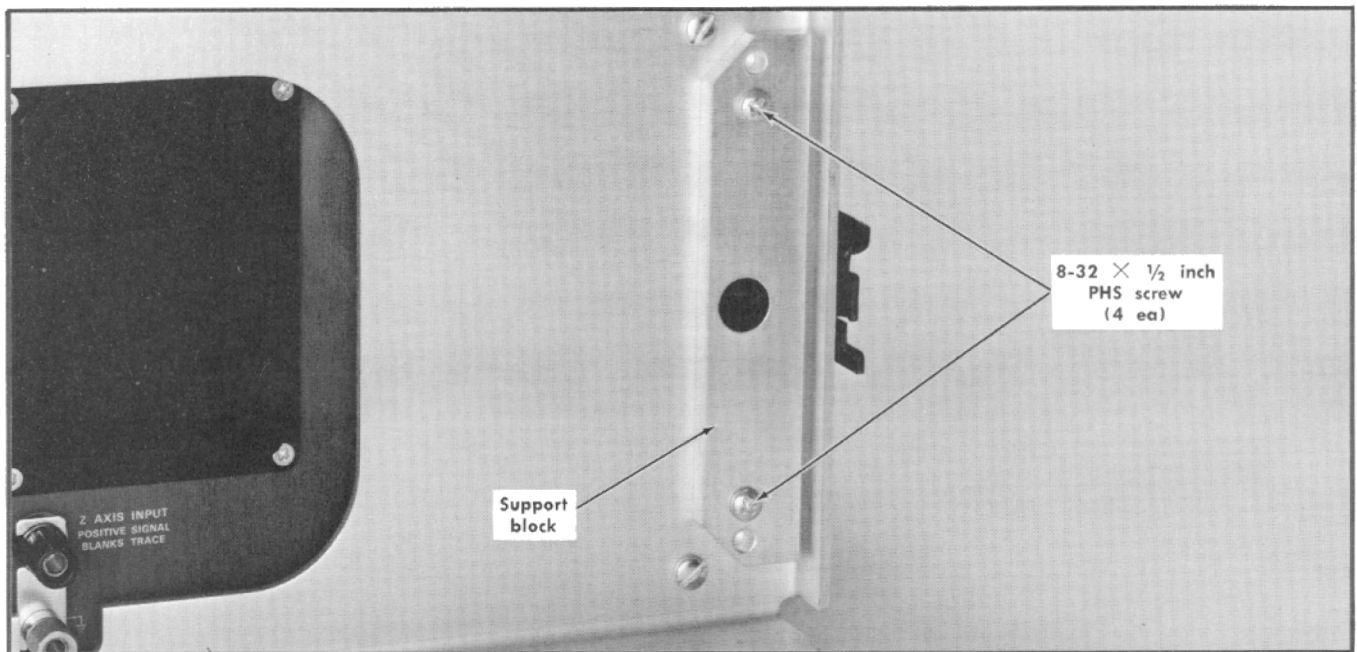

Fig. 10-8. Installing the support block on the instrument.

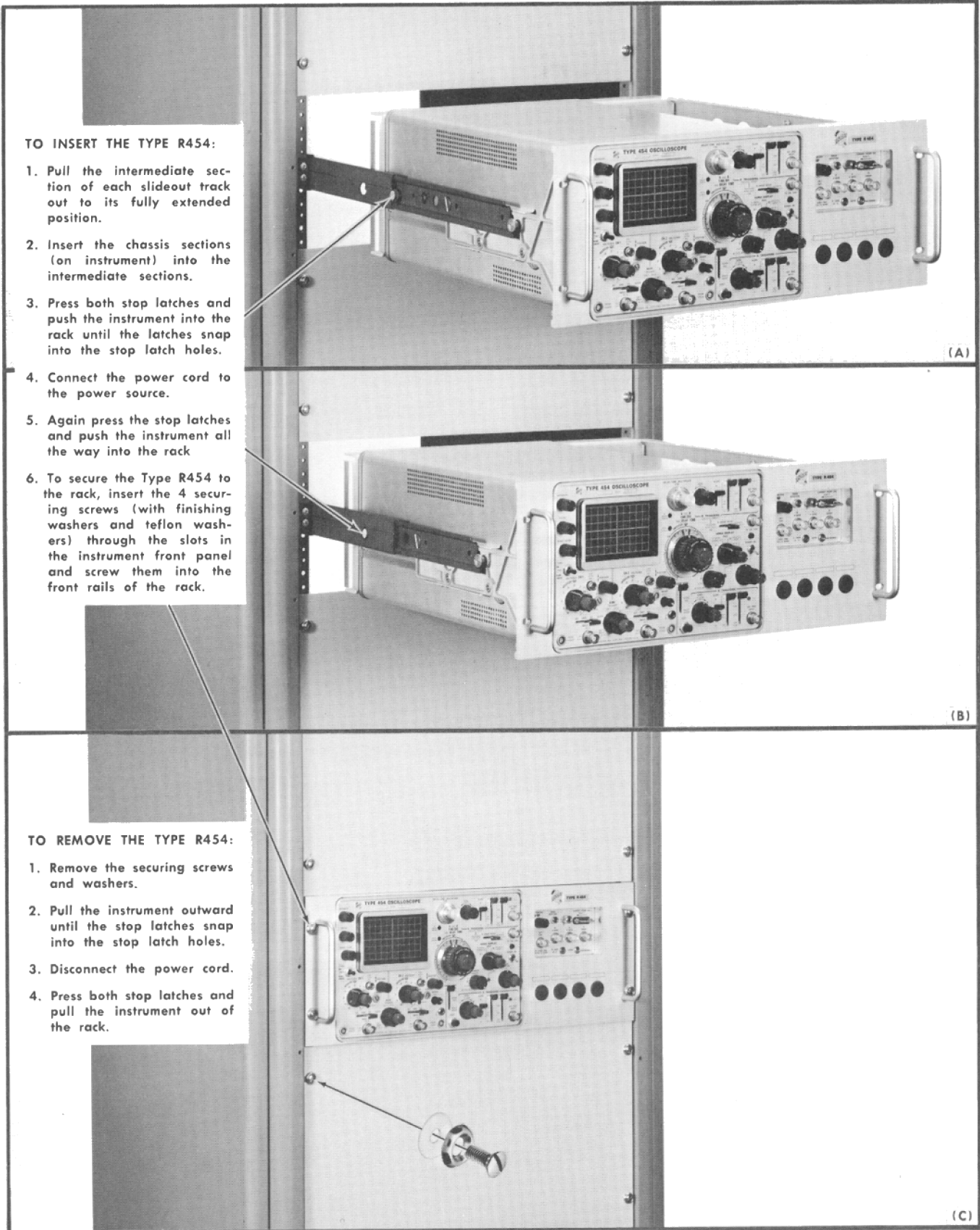

Fig. 10-9. Procedure for inserting or removing the instrument after the slideout tracks have been installed.

TO ADJUST ALIGNMENT:

1. Position the instrument with the pivot screws approximately even with the front rails.
2. Loosen the mounting screws at the front of both stationary sections (left side shown).
3. Allow the tracks to seek their normal positions with the instrument centered in the rack.
4. Tighten the mounting screws.
5. Push the instrument all the way into the rack. If tracks do not slide smoothly, check for correct spacing between the rear supports.
6. Check the vertical positioning of the Type R454 front panel with respect to adjacent instruments or panels. If not correct, reposition as necessary.

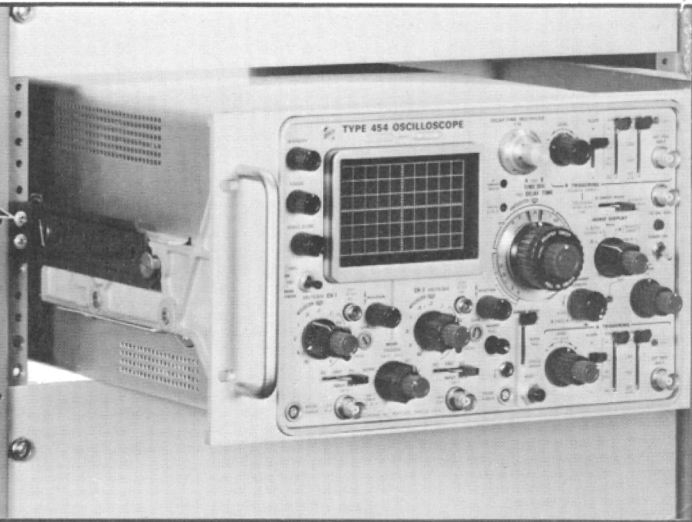

Fig. 10-10. Alignment adjustments for correct operation.

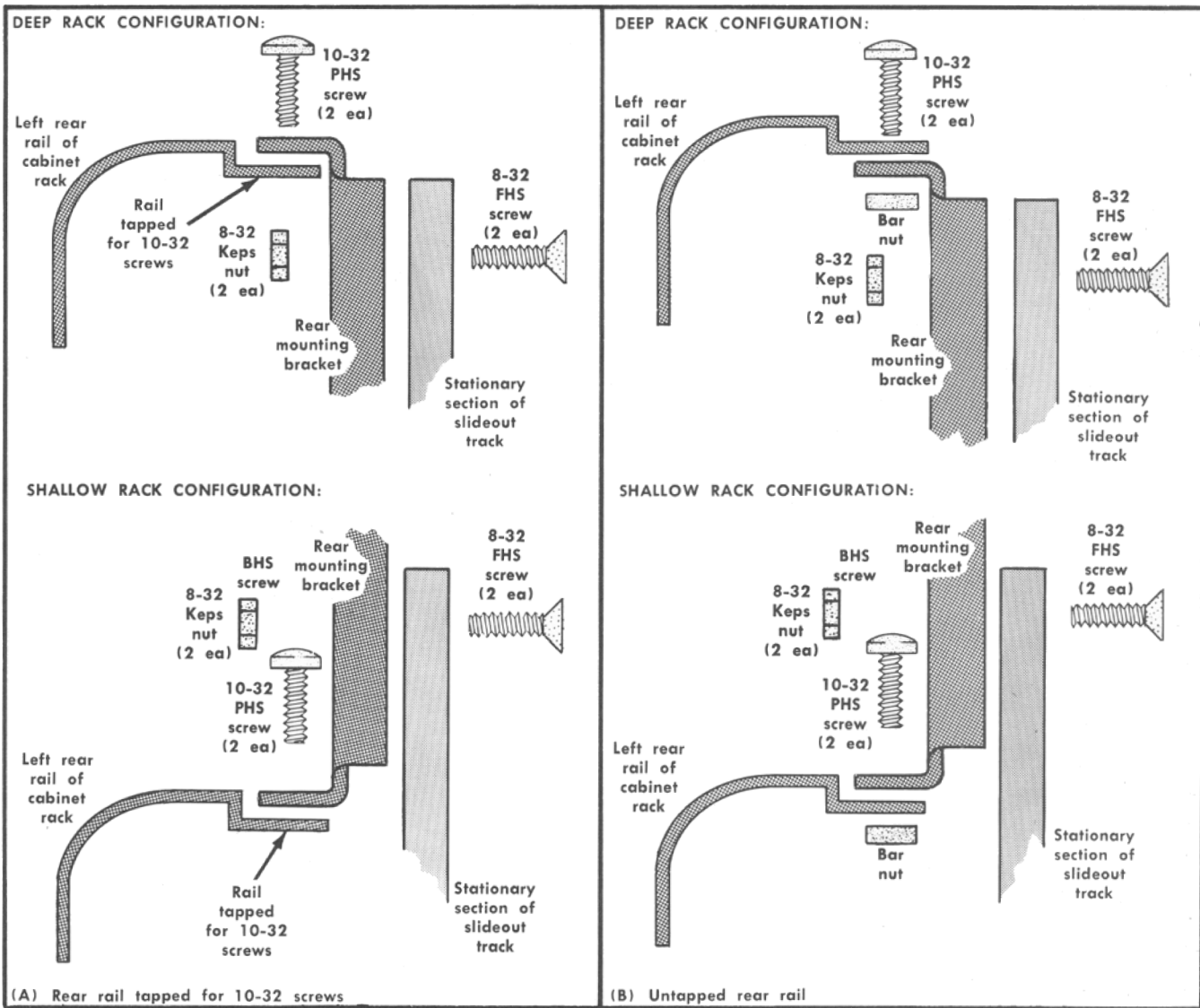
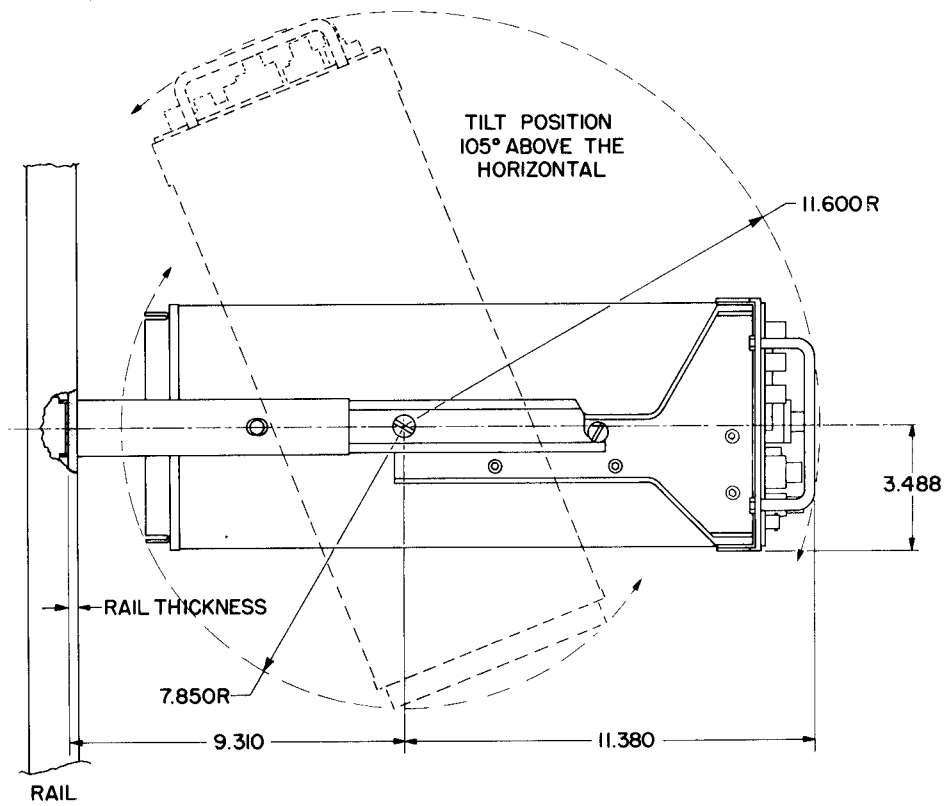
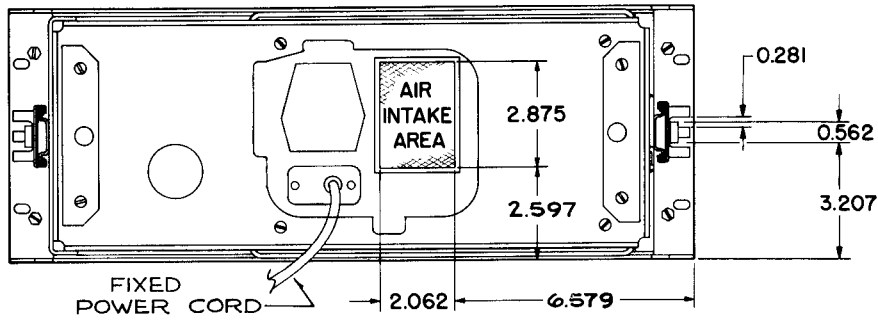
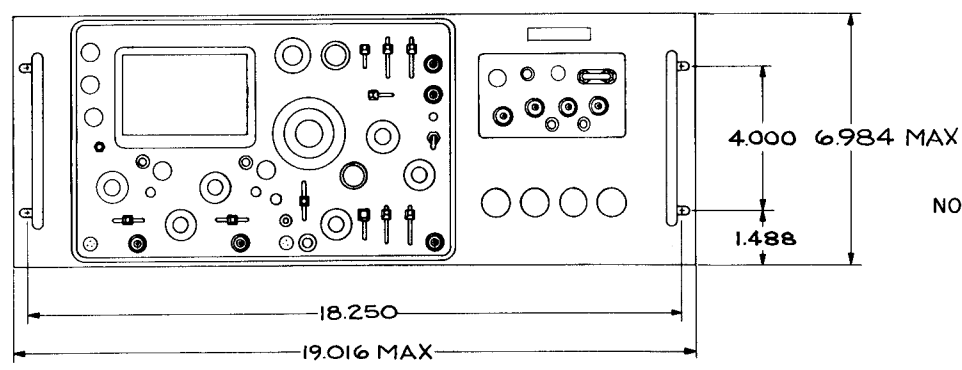
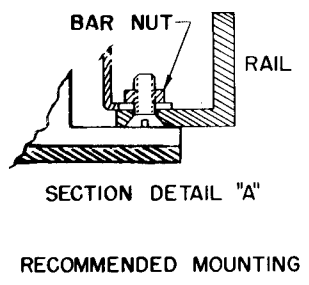
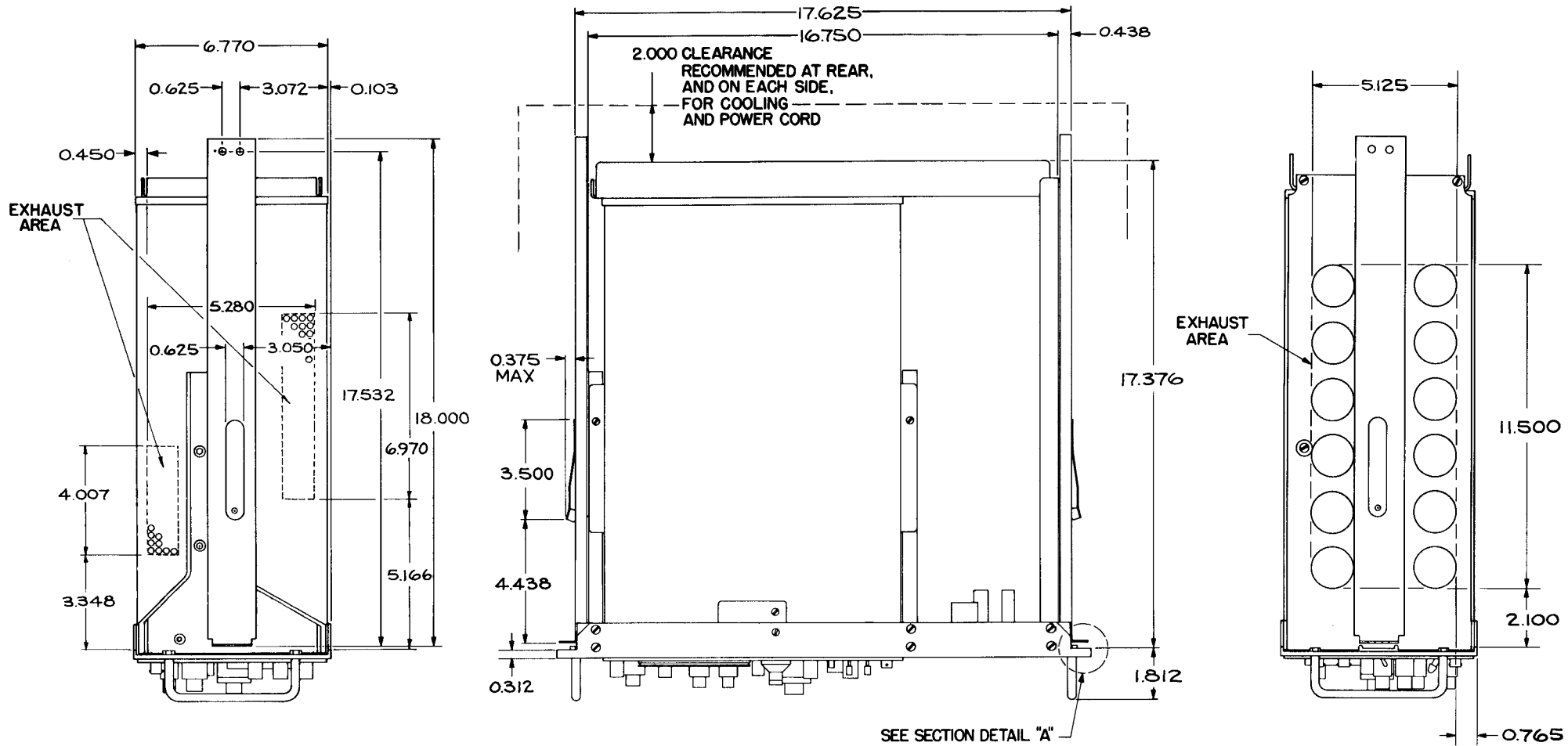

Fig. 10-11. Alternative method of installing the instrument using rear support brackets.

REAR VIEW





TYPE R454

NOTES:
 1. ALL DIMENSIONS ARE REFERENCE DIMENSIONS EXCEPT AS NOTED

MANUAL CHANGE INFORMATION

At Tektronix, we continually strive to keep up with latest electronic developments by adding circuit and component improvements to our instruments as soon as they are developed and tested.

Sometimes, due to printing and shipping requirements, we can't get these changes immediately into printed manuals. Hence, your manual may contain new change information on following pages.

A single change may affect several sections. Sections of the manual are often printed at different times, so some of the information on the change pages may already be in your manual. Since the change information sheets are carried in the manual until ALL changes are permanently entered, some duplication may occur. If no such change pages appear in this section, your manual is correct as printed.

TEXT CORRECTION

Section 5 Performance Check

Page 5-12 Step 27

CHANGE: Step 27 to read as follows:

27. Check Common-Mode Rejection Ratio

REQUIREMENT--10:1 or greater at 50 megahertz.

a. Change the following control settings:

| | |
|-----------------------|-------|
| MODE | CH 1 |
| VOLTS/DIV (CH 1 only) | .1 V |
| A and B TIME/DIV | .1 ms |

b. Connect the medium-frequency constant-amplitude generator to the INPUT CH 1 and CH 2 connectors through the five-nanosecond GR cable, 50-ohm in-line termination and the dual-input coupler.

c. Set the medium-frequency generator for a 4-division display at 50 kilohertz.

d. Change the following control settings:

| | |
|---------------------------|------------|
| MODE | ADD |
| INVERT | Pulled out |
| VOLTS/DIV (CH 1 and CH 2) | 50 mV |

e. Adjust the Channel 2 GAIN adjust (on the front panel) for minimum deflection (optimum common-mode rejection).

f. Without changing the medium-frequency generator output amplitude, change the output frequency to 50 megahertz.

g. CHECK--CRT display for 0.8 division of deflection or less (common-mode rejection ratio 10:1 or better; see Fig. 5-10).

h. Readjust Channel 2 GAIN adjust if necessary in the manner given in Performance Check step 7.

Section 6 Calibration

Page 6-37 Step 36

CHANGE: Step 36 to read as follows:

36. Check Common-Mode Rejection Ratio

a. Test equipment setup is shown in Fig. 6-30.

b. Connect the medium-frequency constant-amplitude generator to the INPUT

CH 1 and INPUT CH 2 connectors through the five-nanosecond GR cable, 50-ohm in-line termination and the dual-input coupler.

c. Change the following control settings:

| | |
|-----------------------|------|
| MODE | CH 1 |
| VOLTS/DIV (CH 1 only) | .1 V |

d. Set the medium-frequency constant-amplitude generator for a 4-division display at 50-kilohertz.

e. Change the following control settings:

| | |
|------------------------|------------|
| MODE | ADD |
| INVERT | Pulled out |
| VOLTS/DIV (CH 1 and 2) | 50 mV |

f. Adjust the Channel 2 GAIN adjust (on the front panel) for minimum deflection (optimum common-mode rejection).

g. Without changing the medium-frequency generator output amplitude, increase the output frequency to 50 megahertz.

h. CHECK--CRT display for 0.8 division of deflection or less (common-mode rejection ratio 10:1 or better; see Fig. 5-10).

i. Readjust Channel 2 GAIN adjust if necessary in the manner given in step 15.

TYPE 454/R454

TENT SN B297980

ELECTRICAL PARTS LIST CORRECTION

CHANGE TO:

R1450

308-0588-00

12 Ω

1/2 W

WW

1%

M15,326/869

TYPE 454/R454

TENT SN B319140

ELECTRICAL PARTS LIST AND SCHEMATIC CORRECTION

CHANGE TO:

R781

315-0114-00

110 k Ω

1/4 W

5%

M15,673/1069

ELECTRICAL PARTS LIST AND SCHEMATIC CORRECTIONS

CHANGE :

| | | | |
|-------|-------------|---------|--------|
| Q753A | 151-0221-00 | Silicon | 2N4258 |
| Q753B | 151-0221-00 | Silicon | 2N4258 |

ADD :

| | | |
|------|-------------|---------------------------|
| L201 | 276-0528-00 | Core, Ferramic Suppressor |
| L204 | 276-0528-00 | Core, Ferramic Suppressor |
| L206 | 276-0528-00 | Core, Ferramic Suppressor |
| L209 | 276-0528-00 | Core, Ferramic Suppressor |
| T178 | 276-0541-00 | Core, Ferrite |

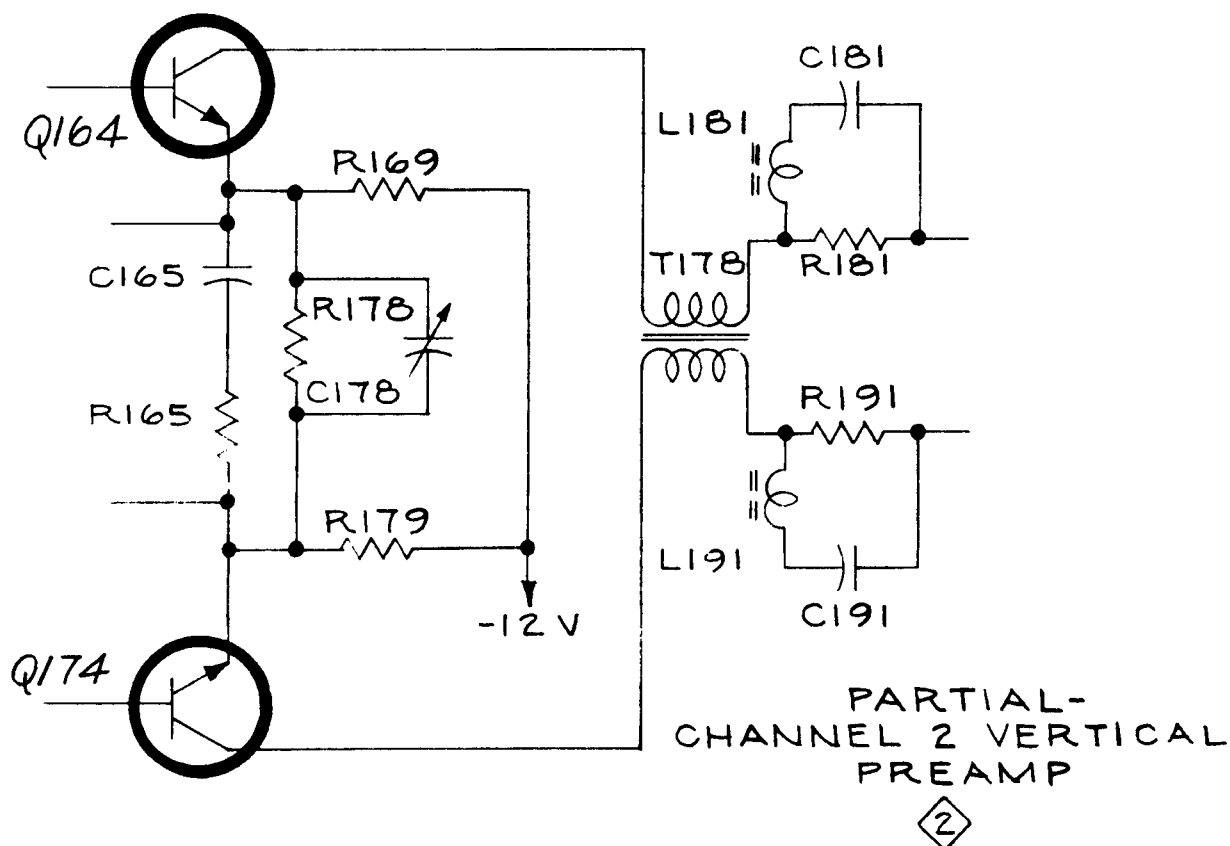

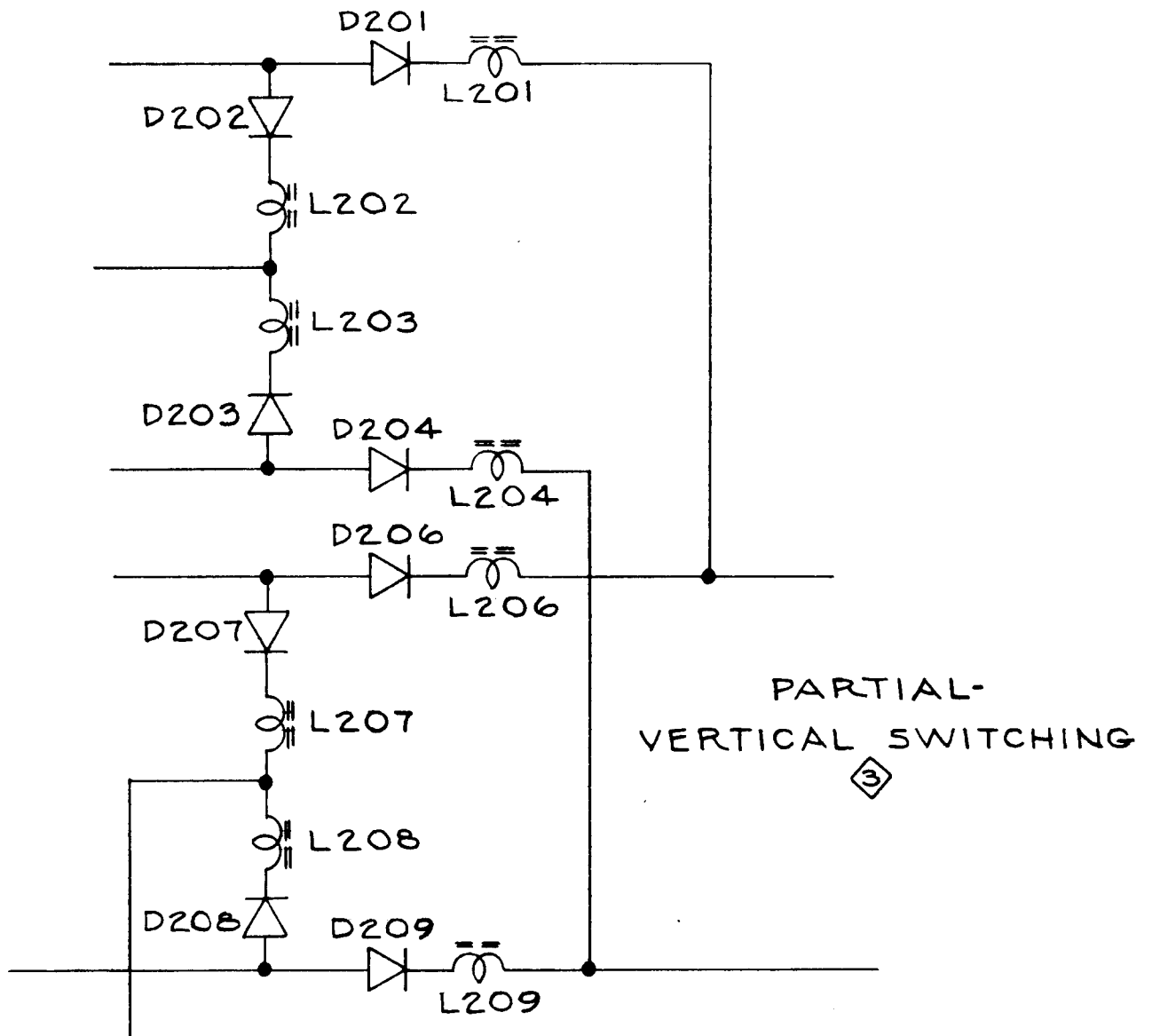

ELECTRICAL PARTS LIST CORRECTION

ADD:

| | | | | | |
|------|-------------|--------|-----|-------|----------|
| C47 | 281-0612-00 | 5.6 pF | Cer | 200 V | ± .5 pF |
| C48 | 281-0611-00 | 2.7 pF | Cer | 200 V | ± .25 pF |
| C147 | 281-0612-00 | 5.6 pF | Cer | 200 V | ± .5 pF |
| C148 | 281-0611-00 | 2.7 pF | Cer | 200 V | ± .25 pF |
| C354 | 281-0613-00 | 10 pF | Cer | 200 V | ± 1 pF |

SCHEMATIC CORRECTION

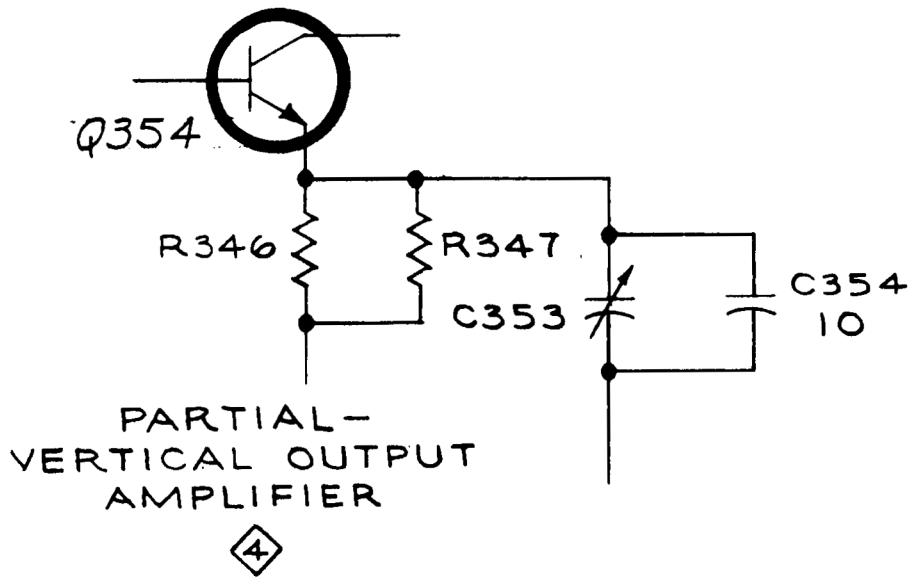

M15,887/1169

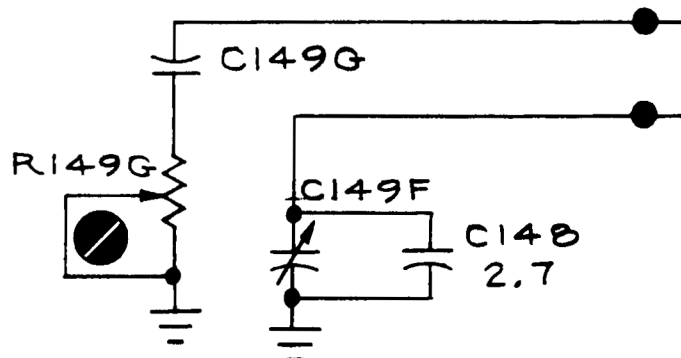
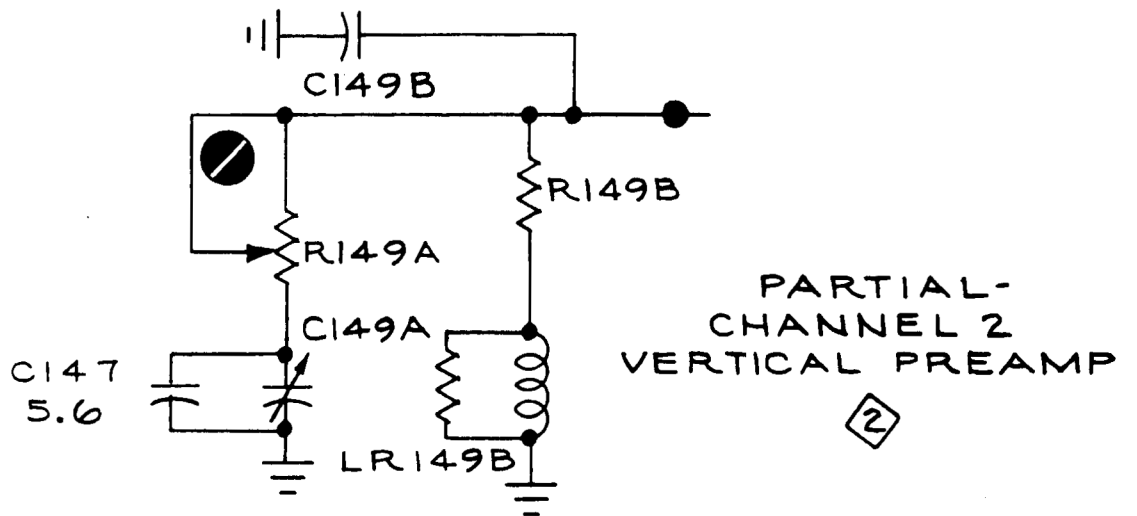
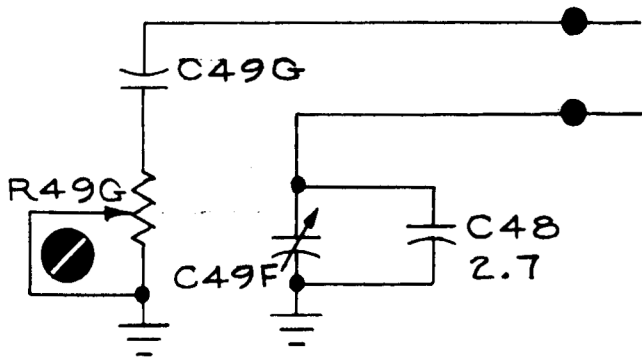
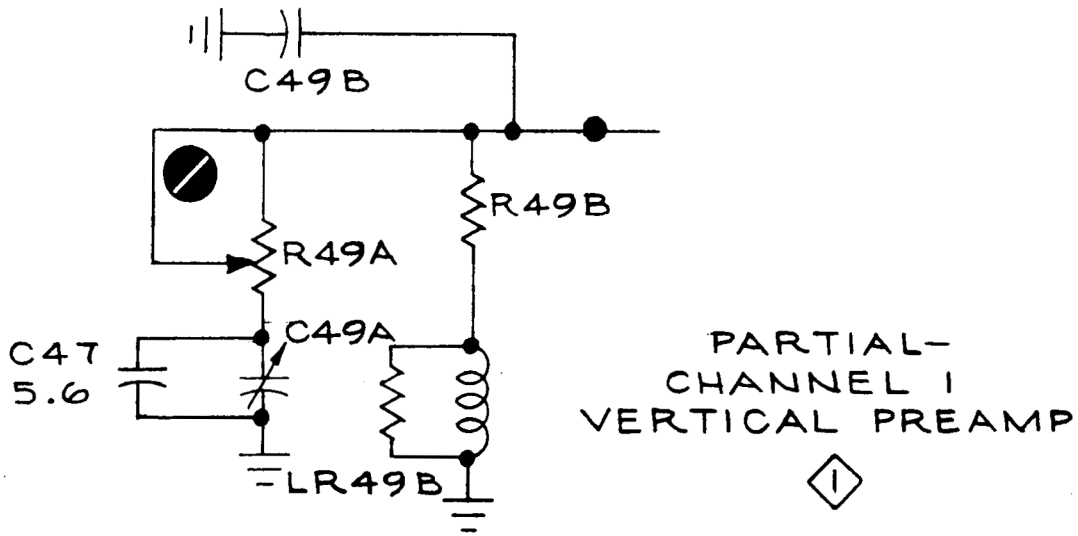

M15,887/1169