

INSTRUMENT REFERENCE BOOK

for the Tektronix type

**11B1**

ruggedized time-base  
plug-in unit

For all serial numbers



©, 1964, Tektronix, Inc., P.O. Box 500  
Beaverton, Oregon. All rights reserved.





Inter-City Mfg. Co., Inc.  
St. Louis, Mo.

## CONTENTS-SALES

### CATALOG

Advertising correction history notice  
Characteristics  
Tentative specifications

### ADVERTISING

File of advertisements



**CORRECTIONS  
FOR  
ADVERTISING PUBLICATIONS**

Long Form Catalog  
#25

Type 11B1  
page 189

jm

**PRESENT FORM:** Under heading EXTERNAL HORIZONTAL INPUT, line now reads:

$\pm 2\%$ , or 1 mV/cm to 20 V/cm in 5 steps, accuracy within

**CORRECT FORM:** Line should read:

$\pm 2\%$ , or 1 V/cm to 20 V/cm in 5 steps, accuracy within



# SECTION 1

## CHARACTERISTICS

### Introduction

The Type 11B1 Time Base plug-in unit is part of a wide-band oscilloscope system designed for operation and storage under severe environmental conditions. The Type 11B1 operates in the right-hand compartment of a Tektronix Type 647 or RM647 Oscilloscope. The environmental characteristics of the Type 11B1 and Type 647 are the same and are described in Section 1 of the Type 647 instruction manual.

The following characteristics apply only when the Type 11B1 is operated in a calibrated Tektronix Type 647 or RM647 oscilloscope.

#### NOTE

Range I and Range II, mentioned in various parts of this section, refer to the ambient air temperature ranges that apply for a particular characteristic. Range I is from 0° C to +40° C; Range II from -30° C to +65° C.

### HORIZONTAL DEFLECTION

Horizontal deflection signals to the oscilloscope system are provided by the Horizontal Preamp in the Type 11B1. The TIME/CM OR HORIZONTAL VOLTS/CM switch on the 11B1 selects the source of the Horizontal Preamp input signals. When the switch is set to the EXT HORIZ INPUT position, the input to the Horizontal Preamp is further selected by the SOURCE switch from the vertical plug-in unit, the line, or the EXT TRIG OR HORIZ IN connector on the front panel. In all other positions of the TIME/CM OR HORIZONTAL VOLTS/CM switch, the input to the Horizontal Preamp is taken from the Sweep Generator.

### Sweep Generator

23 calibrated steps provide sweep rates from 2 sec/cm to 0.1  $\mu$ sec/cm. A direct-reading magnification feature of the Horizontal Preamp provides three additional calibrated steps to extend the fastest rate to 10 nsec/cm (nanosecond =  $10^{-9}$  second). This direct-reading magnifier permits magnification of up to  $\times 40$  or  $\times 50$  depending on the sweep rate to which magnification is applied. An uncalibrated control provides continuously variable sweep rates between 0.1  $\mu$ sec/cm and about 5 sec/cm. A panel lamp lights when the sweep rates are uncalibrated.

**TABLE 1-1**  
Sweep Rate Accuracy

TIME/CM Switch Setting	Displayed Sweep Rate	
	Range I	Range II
2 SEC to .1 SEC	$\pm 3\%$	+4% -6%
50 mSEC to .1 $\mu$ SEC	$\pm 1.5\%$	$\pm 2.5\%$
Additional error when magnification is used to 50 nSEC/CM	$\pm 1\%$	$\pm 1.5\%$
20 nSEC/CM and 10 nSEC/CM	$\pm 2\%$	$\pm 2.5\%$

Sweep rate accuracy of the Type 11B1 is given in Table 1-1.

### External Horizontal Input (to EXT TRIG OR HORIZ IN connector)

Sensitivity	0.1 volt/cm to 2 volts/cm in 5 steps, accurate to $\pm 2\%$ . When the SOURCE switch is placed in the EXT $\div 10$ position, the sensitivity range is from 1 volt/cm to 20 volts/cm, accurate to $\pm 5\%$ . By means of the VARIABLE control, the sensitivity of any step may be decreased by a factor of about 2.5 : 1.
<sup>1</sup> Bandwidth	DC to at least 3 mc ( $-3$ -db point) with COUPLING switch set to DC. With AC coupling, the low-frequency $-3$ -db point is about 16 cycles. The $-3$ -db point is about 17 kc with AC LF REJ coupling.
Input R and C	See Table 1-4.

### TRIGGERING

#### Facilities

SOURCE	Internal, Line, External, and External $\div 10$ .
COUPLING	Ac, Ac Low-Frequency Reject, and Dc.
SLOPE	+ or -.
TRIGGER MODE	Free Run, Auto Baseline—Auto Level, Auto Baseline—Manual Level, Normal and Single Sweep.
LEVEL	See Table 1-5.
HF STABILITY	For jitter reduction at high frequencies.

### Internal Triggering Sensitivity

See Table 1-2.

**TABLE 1-2**

Frequency	Peak-To-Peak Crt Deflection (Range I)	
	Minimum	Typical
To 50 kc	1 mm	2 mm
<sup>2</sup> To 50 mc	5 mm	10 mm

### External Triggering Sensitivity

See Table 1-3.

**TABLE 1-3**

Frequency	Peak-To-Peak Voltage (Range I)	
	Minimum	Typical
<sup>3</sup> To 50 kc	125 mv	150 mv
<sup>2</sup> To 50 mc	200 mv	450 mv

<sup>1</sup>Referenced to 6 cm, centered deflection, at 50 kc.

<sup>2</sup>HF STABILITY control used to minimize jitter above 5 or 10 mc. Jitter is less than 1 mm with a 1 cm, 50 mc/sec signal.

<sup>3</sup>For the AC LF REJ position of the COUPLING switch the minimum peak-to-peak voltage is 200 mv and the typical peak-to-peak voltage is 250 mv.

**EXT TRIG OR HORIZ IN Connector Input Characteristics**

See Table 1-4.

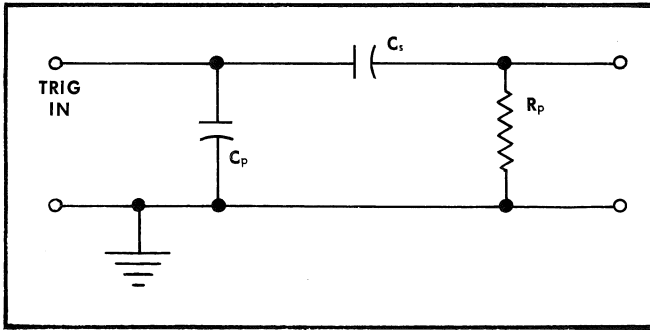

**TABLE 1-4**

SOURCE	COUPLING	C <sub>p</sub> (pf)	C <sub>s</sub>	R <sub>p</sub> (meg Ω) Max	Input Voltage (Peak)
EXT	DC	≈35	shorted	≈1	±75 v
	AC	≈35	≈0.01 μf	≈1	±500 v
	AC LF REJ	≈35	≈100 pf	≈0.09	±500 v
EXT ÷ 10	DC	≈6	shorted	≈10	±500 v
	AC	≈6	≈0.01 μf	≈10	±500 v
10	AC LF REJ	≈6	≈100 pf	≈1.0	±500 v

<sup>1</sup> Maximum usable trigger input voltages are: EXT — ±15 volts peak, EXT ÷ 10 — ±150 volts peak. Trigger input voltages in excess of the above signal levels will cause interference with the normal operation of the trigger generator, sweep generators, and vertical amplifier systems.

**TRIGGERING LEVEL Control Voltage Range (external triggering)**

See Table 1-5

**NOTE**

The voltage range of the TRIGGERING LEVEL control indicates the maximum external peak voltage that will permit triggering at any amplitude point on the signal. Signal with greater amplitudes can be used and will provide triggering, but the range of trigger-point selection is still limited to the TRIGGERING LEVEL control voltage range.

**TABLE 1-5**

SOURCE	COUPLING	Voltage Range	
		Typical	Minimum
EXT	AC, DC, or AC LF REJ	±6.5 v	±5 v
EXT ÷ 10	AC or DC	±65 v	±50 v
	AC LF REJ		±50 v

**Automatic Triggering:** The sweep triggering characteristics stated previously also apply for automatic triggering except that the triggering signal frequency must be higher than about 20 cps.

**Single Sweep:** Permits only one triggered sweep following each reset pulse. Reset pulse can be supplied internally or externally (see Section 2, "Normal Sweep Operation"). External pulse amplitude must be at least 5 volts peak; risetime must be 5.0 μsec or less.

**OUTPUT SIGNALS**

**+ GATE**

- Output Voltage: About +14.6 volts peak to peak into a high resistance load.
- Output Resistance: About 1600 ohms.
- Output Current: About 9 ma into zero ohms.

**SWEEP**

- Output Voltage: About +10 volts peak into a high-resistance load.
- Output Resistance: About 750 ohms.
- Output Current: About 13 ma peak into zero ohms.

**MECHANICAL CHARACTERISTICS**

**Construction**

Aluminum-alloy chassis with chrome-plated brass side rails. Front panel is anodized aluminum.

**Dimensions (approx).**

- 6¼ inches high.
- 4¼ inches wide.
- 14½ inches deep (overall).

**Accessories**

Information on accessories for use with this instrument is included at the rear of the mechanical parts list.



## 11B1 GENERAL DESCRIPTION

THE TYPE 11B1 is a ruggedized time-base unit for the Type 647 Oscilloscope. It features a single wide-range time base and a direct-reading 1X to 50X sweep magnifier.

**SWEEP RANGE** from 0.1  $\mu\text{sec}/\text{cm}$  to 2  $\text{sec}/\text{cm}$  is in 23 calibrated steps with 1-2-5 sequence. Sweep rates are continuously variable uncalibrated from 0.1  $\mu\text{sec}/\text{cm}$  to approximately 5  $\text{sec}/\text{cm}$ . A front-panel lamp indicates uncalibrated sweep rates.

**DIRECT-READING SWEEP MAGNIFIER** provides up to 50X expansion, depending on the basic sweep rate. The magnifier knob indicates directly the TIME/CM rate of the magnified sweep. With the magnifier, the calibrated sweep rate can be extended to 10  $\text{nsec}/\text{cm}$ .

<u>ACCURACIES</u>	<u>0°C to +40°C</u>	<u>-30°C to +65°C</u>
2 $\text{sec}/\text{cm}$ to 0.1 $\text{sec}/\text{cm}$	$\pm 3\%$	+4%, -6%
50 $\text{msec}/\text{cm}$ to 0.1 $\mu\text{sec}/\text{cm}$	$\pm 1.5\%$	$\pm 2.5\%$
Magnifier Additional:		
Up to 50 $\text{nsec}/\text{cm}$	$\pm 1\%$	$\pm 1.5\%$
20 or 10 $\text{nsec}/\text{cm}$	$\pm 2\%$	$\pm 2.5\%$

**SINGLE SWEEP OPERATION** facilitates photographic recording of waveforms. A Reset push-button arms the sweep to fire on the next received trigger. The sweep can also be remotely reset, through a rear-panel jack on the Type 647 or RM647 Oscilloscope. After firing once, the sweep is locked out until rearmed by pressing the Reset button. The button lights to indicate when the sweep is armed to fire on the next received trigger.

+ GATE and SAWTOOTH OUTPUTS are available at the front panel. Output is 15 volts from the + gate and +10 volts from the sweep.

## TENTATIVE SPECIFICATIONS

EXTERNAL HORIZONTAL INPUT provides for horizontal beam deflection with an external source. Horizontal sensitivity is 0.1 v/cm to 2 v/cm in 5 steps, accuracy within  $\pm 2\%$ , or 1 v/cm to 20 v/cm in 5 steps, accuracy within  $\pm 5\%$ , using the  $\div 10$  input attenuator. Sensitivity is continuously variable uncalibrated between steps. Passband is DC to at least 3 mc (3 db down). With AC coupling the low-frequency 3 db point is approximately 16 cps. With AC Low-Frequency Reject the low-frequency 3 db point is 17 kc. Input impedance is 1 megohm paralleled by approximately 35 pf in the "Ext" input position, or 10 megohms paralleled by approximately 6 pf in the "Ext  $\div 10$ " position.

### TRIGGER

Trigger modes include Free-Running, Single-Sweep, Normal, and 2 types of Automatic Base Line operation (manual or fixed trigger level). The Automatic Base Line provides a bright reference trace (regardless of sweep speed) when no input signal is applied, and provides stable triggered-sweeps for triggering signal repetition rates above 20 cps.

FIXED-LEVEL AUTOMATIC OPERATION presets the trigger level to near zero. It offers the most triggering convenience for high duty-cycle waveforms.

MANUAL-LEVEL AUTOMATIC OPERATION offers full operator control of trigger level for both + and - slope triggering, even on signals of very low duty cycle.

TRIGGER LEVEL adjusts to allow sweep triggering at any selected point on either the rising or falling portion of the waveform. Level range for internal triggering covers the entire screen; for external triggering it is  $\pm 5v$ , or  $\pm 50v$  using the  $\div 10$  external trigger attenuator.

TRIGGER SOURCE can be internal, external, external  $\div 10$ , or line.

TRIGGER COUPLING can be DC, AC (-3db at 16 cps), or AC low-frequency reject (-3 db at 17 kc).

TRIGGER REQUIREMENTS are a 2 mm deflection or 125 mv external signal to 50 kc, increasing to a 1 cm deflection or 250 mv external signal to 50 mc. These requirements apply to Normal triggering, and also Automatic Base Line when using manual-level control.

HIGH-FREQUENCY STABILITY changes the time base recovery time to reduce high-frequency jitter.

FREE-RUN LIGHT warns the operator when the sweep is free running. The indicator is particularly useful when setting up triggering in the automatic mode from a high repetition-rate external trigger source.





# t e n t a t i v e

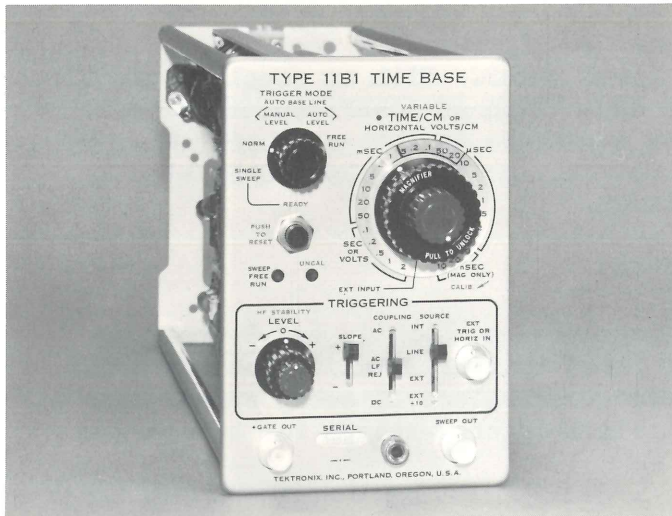

## TIME BASE UNIT

### TYPE 11B1

THE TYPE 11B1 is a ruggedized time-base unit for the Type 647 Oscilloscope. It features a single wide-range time base and a direct-reading 1X to 50X sweep magnifier.

**SWEEP RANGE** from 0.1  $\mu$ sec/cm to 2 sec/cm is in 23 calibrated steps with 1-2-5 sequence. Sweep rates are continuously variable uncalibrated from 0.1  $\mu$ sec/cm to approximately 5 sec/cm. A front-panel lamp indicates uncalibrated sweep rates.

**DIRECT-READING SWEEP MAGNIFIER** provides up to 50X expansion, depending on the basic sweep rate. The magnifier knob indicates directly the TIME/CM rate of the magnified sweep. With the magnifier, the calibrated sweep rate can be extended to 10 nsec/cm.

ACCURACIES	0°C to +40°C	-30°C to +65°C
2 sec/cm to 0.1 sec/cm	$\pm 3\%$	+4%, -6%
50 msec/cm to 0.1 $\mu$ sec/cm	$\pm 1.5\%$	$\pm 2.5\%$
Magnifier additional:		
Up to 50 nsec/cm	$\pm 1\%$	$\pm 1.5\%$
20 or 10 nsec/cm	$\pm 2\%$	$\pm 2.5\%$

**SINGLE SWEEP OPERATION** facilitates photographic recording of waveforms. A Reset pushbutton arms the sweep to fire on the next received trigger. The sweep can also be remotely reset, through a rear-panel jack on the Type 647 or RM647 Oscilloscope. After firing once, the sweep is locked out until rearmed by pressing the Reset button. The button lights to indicate when the sweep is armed to fire on the next received trigger.

+ GATE and SAWTOOTH OUTPUTS are available at the front panel. Output is 15 volts from the + gate and +10 volts from the sweep.

specifications →

# TEKTRONIX, INC.

TRANSITION FROM ENGINEERING MODEL TO PRODUCTION MODEL MAY REQUIRE MINOR SPECIFICATION CHANGES. FINAL SPECIFICATIONS WILL BE RELEASED LATER.

EXTERNAL HORIZONTAL INPUT provides for horizontal beam deflection with an external source. Horizontal sensitivity is 0.1 v/cm to 2 v/cm in 5 steps, accuracy within  $\pm 2\%$ , or 1 v/cm to 20 v/cm in 5 steps, accuracy within  $\pm 5\%$  using the  $\div 10$  input attenuator. Sensitivity is continuously variable uncalibrated between steps. Passband is dc to at least 3 Mc (3-db down). With ac coupling the low-frequency 3-db point is approximately 16 cps. With AC Low-Frequency Reject the low-frequency 3-db point is 17 kc. Input impedance is 1 megohm paralleled by approximately 35 pf in the "Ext" input position, or 10 megohms paralleled by approximately 6 pf in the "Ext  $\div 10$ " position.

#### TRIGGER

Trigger modes include Free-Running, Single-Sweep, Normal, and 2 types of Automatic Base Line operation (manual or fixed trigger level). The Automatic Base Line provides a bright reference trace (regardless of sweep speed) when no input signal is applied, and provides stable triggered-sweeps for triggering signal repetition rates above 20 cps.

FIXED-LEVEL AUTOMATIC OPERATION presets the trigger level to near zero. It offers the most triggering convenience for high duty-cycle waveforms.

MANUAL-LEVEL AUTOMATIC OPERATION offers full operator control of trigger level for both + and - slope triggering, even on signals of very low duty cycle.

TRIGGER LEVEL adjusts to allow sweep triggering at any selected point on either the rising or falling portion of the waveform. Level range for internal triggering covers the entire screen; for external triggering it is  $\pm 5$  v, or  $\pm 50$  v using the  $\div 10$  external trigger attenuator.

TRIGGER SOURCE can be internal, external, external  $\div 10$ , or line.

TRIGGER COUPLING can be dc, ac (-3 db at 16 cps), or ac low-frequency reject (-3 db at 17 kc).

TRIGGER REQUIREMENTS are a 2-mm deflection or 125-mv external signal to 50 kc, increasing to a 1-cm deflection or 250-mv external signal to 50 Mc. These requirements apply to Normal triggering, and also Automatic Base Line when using manual-level control.

HIGH-FREQUENCY STABILITY changes the time base recovery time to reduce high-frequency jitter.

FREE-RUN LIGHT warns the operator when the sweep is free running. The indicator is particularly useful when setting up triggering in the automatic mode from a high repetition-rate external trigger source.

Price and availability will be released later.

**Tektronix, Inc.**

P. O. BOX 500 • BEAVERTON, OREGON 97005 • Phone: (Area Code 503) Mitchell 4-0161 • Telex: 036-691  
TWX: 503-291-6805 • Cable: TEKTRONIX • OVERSEAS DISTRIBUTORS IN 25 COUNTRIES  
TEKTRONIX FIELD OFFICES in principal cities in United States. Consult Telephone Directory  
Tektronix Australia Pty., Ltd., Melbourne; Sydney • Tektronix Canada Ltd., Montreal; Toronto  
Tektronix International A.G., Zug, Switzerland • Tektronix Ltd., Guernsey, C. I. • Tektronix U. K. Ltd., Harpenden, Herts



Inter-City Mfg. Co., Inc.  
St. Louis 11, Mo.



# CONTENTS-ENGINEERING

## TECHNOLOGY

Operating instructions  
Circuit description  
11B1 block study



# SECTION 2

## OPERATING INSTRUCTIONS

### FRONT PANEL CONTROLS AND SWITCHES

#### NOTE

A more complete description of the controls and switches is included under "Standard Sweep Operation" later in this section.

- TRIGGER MODE** Selects the manner in which the Time Base sweeps are initiated. For example:
- FREE RUN** In this position, recurrent sweeps are provided. The completion of one sweep causes the next to begin.
- AUTO BASE LINE-AUTO LEVEL** Automatic sweep. Permits each sweep to be triggered when the triggering-signal repetition rate is about 20 cps or greater. For lower repetition rates or in the absence of a triggering signal, the sweeps are recurrent, as in the FREE RUN position.
- AUTO BASE LINE-MANUAL LEVEL** The same as AUTO BASE LINE—AUTO LEVEL except that the TRIGGERING LEVEL control must be adjusted so that the sweep triggers at the desired point on the triggering signal.
- NORM** Normal method of operation. Each sweep is triggered by the signal from the internal trigger generator.
- SINGLE SWEEP and RESET** Often used when displays of nonrepetitive signals are photographed. When the RESET lamp is lit, the time base is ready to produce one triggered sweep.

#### TRIGGERING Block

- SOURCE** Selects the source of the triggering signal:
- INT** Internal. Obtains the sweep triggering signal from the vertical plug-in unit.
- LINE** Obtains the sweep triggering signal from a low-voltage winding on the oscilloscope power transformer.
- EXT and EXT ÷ 10** External and external divided-by-ten. Permits external signals applied to the EXT TRIG OR HORIZ IN connector to be used for sweep triggering. High-amplitude triggering signals can be attenuated by using the EXT ÷ 10 position.
- COUPLING** Permits acceptance or rejection of some triggering signal characteristics:
- AC** Rejects dc and attenuates very low-frequency ac triggering signals.
- AC LF REJ** Ac low-frequency reject. Rejects dc and discriminates against low frequency ac triggering signals. The -3-db point is 17 kc.
- DC** Accepts ac and dc triggering signals.

**SLOPE (+ or -)** Determines whether sweep triggering will occur during the positive-going (+) or negative going (-) portion of the triggering signal.

**LEVEL** Selects the amplitude point on the triggering signal where sweep triggering will occur.

**HF STABILITY** High-frequency stability. Used if necessary with triggering signals above 5 mc to obtain best display stability. Has no effect at lower triggering-signal frequencies.

**TIME/CM OR HORIZONTAL VOLTS/CM** Provides 23 calibrated display sweep rates (unmagnified). The number opposite the dot on the MAGNIFIER knob skirt always indicates the sweep time per centimeter as long as the VARIABLE control is in the CALIB position. The number bracketed by the two black lines on the clear plastic knob flange is the **unmagnified** sweep time per centimeter. To change the **unmagnified** sweep rate, the concentric flange and the MAGNIFIER knob must first be interlocked by positioning the dot on the MAGNIFIER knob between the two black lines on the flange. When the flange is positioned so that the two black lines bracket the EXT HORIZ INPUT position, the signal selected by the SOURCE switch is connected directly to the horizontal pre-amplifier. In the EXT HORIZ INPUT position of the TIME/CM OR HORIZONTAL VOLTS/CM switch, horizontal deflection is provided by the signal selected by the SOURCE switch rather than by the time-base generator.

**MAGNIFIER** Provides magnification of the horizontal display up to 40X or 50X in five direct-reading steps. (Magnification of the three fastest **unmagnified** sweep rates is limited to 10 nsec/cm.) For example, at 10X magnification, the 1-centimeter segment at the center of an unmagnified crt display is horizontally expanded to full graticule width. Any other 1-centimeter segment of the original unmagnified display may then be observed in magnified form by turning the oscilloscope HORIZ POSITION controls. To determine the degree of magnification, divide the number bracketed by the two black lines in the clear plastic flange by the number adjacent to the dot on the MAGNIFIER knob.

**VARIABLE** Provides continuously variable uncalibrated sweep rates between about 0.4 and 1.0 times that indicated by the TIME/CM switch. Whenever the VARIABLE knob is not set to CALIB, the UNCAL lamp lights.

## Operating Instructions—Type 11B1

When the TIME/CM switch is set to the EXT HORIZ INPUT position, the VARIABLE knob provides a 2.5 : 1 change in horizontal amplifier sensitivity.

### STANDARD SWEEP OPERATION

The control and switch settings listed under "First-Time Operation" later in this section establish the basic conditions necessary for most measurements. In many applications, it is desirable for a repetitive signal to produce a stationary display on the crt so the waveform can be examined in detail. For this type of display, the start of each sweep must bear a definite fixed-time relationship to the events in the input signal. This can be accomplished by using the displayed Signal on another related Signal to start (trigger) single or repetitive sweep. The following is a detailed description of the control and switch settings which provide complete control over the means of triggering the sweep.

### TRIGGER MODE

**FREE RUN.** Free-running operation produces continuously repetitive sweeps even in the absence of a triggering signal. These sweeps provide a reference trace, as do the AUTO positions. This method of operation is useful in applications where a device under test requires a trigger or input signal. The front-panel +GATE OUT or SWEEP OUT signal may be used to operate the device under test. The resulting signal displayed on the crt will then be synchronized with the sweep.

**AUTO BASE LINE.** These positions are frequently used for ease of operation and because of the reference trace produced in the absence of a triggering signal. In either the MANUAL LEVEL or AUTO LEVEL positions, the time base free runs without the application of a trigger. If a triggering signal is received, the free running is interrupted, but this first event in the signal does not trigger a sweep. If the first signal event is followed by a second event within about 80 msec, a triggered sweep is initiated, and if not, the free running resumes. Since the dormant period is limited to about 80 msec, signal frequencies below about 20 cps cannot produce a triggered sweep in the AUTO BASE LINE modes. For such signals, the NORM mode of operation is used.

With the SOURCE switch set to INT and the TRIGGER MODE switch set to AUTO LEVEL, the sweep will trigger on signals that produce about 1 cm or more of vertical deflection. Little or no resetting of triggering controls is required when operating in this mode. However, the AUTO BASE LINE—AUTO LEVEL mode will not trigger on low duty-cycle, negative going waveforms.

When operating in the MANUAL LEVEL mode, it is necessary to adjust the LEVEL control to lock the sweep with the triggering signal, but the sweep can be triggered with signals that produce much less vertical deflection than is required when operating in the AUTO LEVEL mode.

**NORM.** In the NORM or normal mode, the time base is dormant in the absence of a triggering signal. Each sweep must be initiated by a triggering signal.

**SINGLE SWEEP.** Single sweep is often used when photographing non-repetitive waveforms and in other applications where the vertical input signal continually varies in ampli-

tude, shape, or time interval. A continuous display of such signals would appear as a jumbled mixture of many different waveforms and would yield little or no useful information. The Type 11B1 permits a single sweep to be presented with the elimination of all subsequent sweeps. The information in the one sweep is thus clearly recorded without the confusion resulting from multiple nonrepetitive traces.

When the TRIGGER MODE switch is set to SINGLE SWEEP, the time base becomes inoperative. The time base can be "reset" to the triggerable condition by pressing the RESET button or by applying a fast-rise positive-going pulse of about 5-volts amplitude to pin F of J101 on the rear panel of the oscilloscope (pin C is ground). If there is sufficient delay before triggering, the RESET lamp will light to show that the time base is ready to be triggered. When the time base has been triggered and one sweep completed the time base again becomes inoperative and the lamp extinguishes.

### SOURCE

**INT.** It is usually easiest to obtain the sweep triggering signal internally (INT) from the vertical deflection system.

**LINE.** If the displayed signal frequency is related to the power-line frequency, the line source can be used. This source is useful when the displayed signal does not allow internal triggering.

**EXT.** External triggering is often used when signal tracing in amplifiers, phase-shift networks, and wave-shaping circuits. The signal from a single point in the circuit can be connected to the EXT TRIG OR HORIZ IN connector through a signal probe or a cable. With this signal triggering the sweep, it is possible to observe the shaping, amplification, and time relationship of a signal at various points in the circuit without resetting the triggering controls

**EXT ÷ 10.** The only difference between external (EXT) and external divided-by-10 (EXT ÷ 10) is that the latter attenuates the external triggering signal. Attenuation of high-amplitude external triggering signals is desirable to broaden the TRIGGERING—LEVEL control range.

### COUPLING

**DC.** Dc coupling allows the trigger circuits to receive signals of all frequencies from dc upward. It is best to dc couple for very low frequency signals (below about 20 cps).

**AC.** Ac coupling rejects the dc component of triggering signals and increasingly attenuates ac triggering signals as the frequency decreases. This position of the coupling switch is not normally used for triggering signals below about 20 cps, but this is the most used position of the switch.

**AC LF REJ.** Ac low-frequency reject coupling rejects the dc component of triggering signals and increasingly attenuates ac signals as frequency decreases (—3-db point 17 kc). If line-frequency hum is mixed with a desired high-frequency triggering signal, best results are obtained by using this position of the COUPLING switch.

Ac low-frequency reject coupling should also be used when triggering internally from multi-trace plug-in units operated in the alternate-trace mode (unless the "trigger from a single channel only" feature of the plug-in is used). For additional information, see the multi-trace vertical plug-in unit instruction manual.

## SLOPE

Sweeps can be triggered during either the rising or falling portion of the triggering signal. When the display consists of several cycles of the input signal, either setting of the SLOPE switch may be used. However, if it is desired to display less than one full cycle of the input signal, the SLOPE switch permits the sweep to start on either the rising (+ slope) or falling (— slope).

## LEVEL

The LEVEL control determines the instantaneous voltage on the triggering signal at which the sweep is triggered. (This instantaneous voltage can also include a dc level if the COUPLING switch is set to DC.) With the SLOPE switch at +, adjusting the LEVEL control makes it possible to trigger the sweep consistently at virtually any point on the positive slope of the triggering signal. Likewise, with the SLOPE switch at —, adjusting the LEVEL control makes it possible to trigger at virtually any point on the negative slope of the triggering signal.

## HF STABILITY

The HF STABILITY control is used only when the triggering-signal frequency is greater than about 5 mc, and then only if the triggered sweep display tends to jitter horizontally. In such cases, the control is set for minimum jitter. At lower frequencies the setting of the HF STABILITY control has little effect.

## TIME/CM OR HORIZONTAL VOLTS/CM

The Time Base has 23 calibrated sweep rates ranging from 0.1  $\mu\text{sec/cm}$  to 2 sec/cm (unmagnified). See Fig 2-1. The

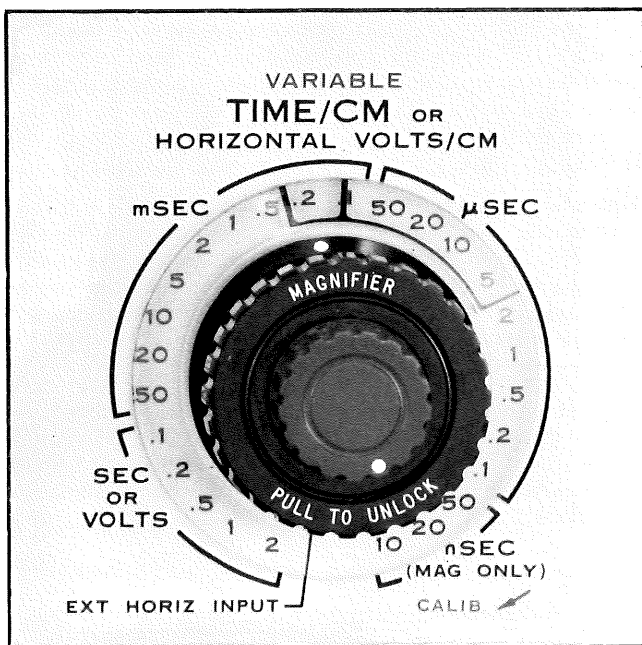

Fig. 2-1. TIME/CM OR HORIZONTAL VOLTS/CM and MAGNIFIER knobs.

number opposite the dot on the MAGNIFIER knob indicates the sweep time per centimeter as long as the VARIABLE control is in the CALIB position. The **unmagnified** sweep rate value being used appears between the two black lines on the clear plastic flange of the TIME/CM control. The VARIABLE control and MAGNIFIER switch, used in conjunction with the TIME/CM switch, permit the sweep rate to be varied continuously between 10 nsec/cm and about 5 sec/cm. (The MAGNIFIER switch is discussed under "MAGNIFIER".) All sweep rates obtained with the VARIABLE control in any but the fully clockwise position are uncalibrated. Uncalibrated sweep rates are indicated when the UNCAL lamp is lit.

When the flange is positioned so that the two black lines bracket the EXT HORIZ INPUT position and the SOURCE switch is set to EXT or EXT  $\div$  10, the horizontal amplifier input is connected to the EXT TRIG OR HORIZ IN connector and accepts external horizontal deflection signals. In this mode of operation, five ranges of horizontal deflection sensitivity are available for each of the EXT positions of the SOURCE switch. With the SOURCE switch set to EXT, the five sensitivity ranges are from 0.1 volt/cm to 2 volts/cm. In the EXT  $\div$  10 position, the ranges are from 1 volts/cm to 20 volts/cm.

To position the TIME/CM switch to the EXT HORIZ INPUT position, turn the MAGNIFIER knob until the dot on the knob is positioned between the two black lines on the clear plastic flange. Turn the knob until the two black lines on the flange bracket the position marked "EXT HORIZ INPUT". The external horizontal deflection sensitivity may now be selected by pulling the MAGNIFIER knob outward to unlock it, then, while holding the knob out, turn it to the desired volts/cm.

## MAGNIFIER

The sweep ranges between 2 sec/cm and 0.5  $\mu\text{sec/cm}$  can be magnified up to 40 $\times$  or 50 $\times$  in 5 steps. The degree of magnification is the ratio between the indicated magnified rate (number opposite the dot on the skirt of the MAGNIFIER knob) and the indicated un magnified rate (number bracketed by two black lines on the clear plastic flange). Since the magnified display rate is always direct reading, it is seldom necessary to determine the actual magnifying factor used.

Above 0.5  $\mu\text{sec}$  the number of steps of magnification decrease until at the .1  $\mu\text{SEC}$  setting of the TIME/CM switch only three steps of magnification are available. The .1  $\mu\text{SEC}$  position is the highest sweep rate to which the TIME/CM switch can be set, but by the use of the three additional magnified positions, an effective sweep rate of 10 nSEC/CM is obtained.

## FIRST-TIME OPERATION

The following control and switch settings for the Type 11B1 can be used for a wide range of measurements. The operating conditions established by these settings also provide a starting point for the operator who is learning to use the instrument.

TRIGGER MODE	AUTO BASE LINE-MANUAL LEVEL
COUPLING	AC

## Operating Instructions—Type 11B1

SOURCE	INT
VARIABLE (TIME/CM)	CALIB (fully clockwise)
MAGNIFIER	Locked to TIME/CM switch

The Type 11B1 now provides the time base for measurements of vertical deflection signals above about 20 cps. In many cases, only the TIME/CM switch and the TRIGGERING LEVEL control require readjustment when progressing from one measurement to the next.

The appropriate TIME/CM switch setting depends on the frequency of the applied signal and the type of measurement. For example, to observe about 2 cycles of the oscilloscope 1-Kc Calibrator signal, set the TIME/CM switch to .2 mSEC.

The following conditions must exist to obtain a triggered display of the vertical deflection signal with the preceding control settings:

1. The frequency of the vertical deflection signal must be about 20 cps or greater (below 20 cps, the TRIGGER MODE switch must be set to NORM).
2. The vertical deflection amplitude must be at least 2 mm at 50 kc.
3. The TRIGGERING LEVEL control must be properly adjusted.

If the first two conditions are met, a stable display will be obtained with the LEVEL control set near zero. When the observed deflection amplitude is a fraction of a centimeter, the range of adjustment is relatively narrow but broadens with increased vertical deflection.

### Operating Techniques

The following procedures are designed to acquaint the operator with the functions of the various controls on the Type 11B1.

**Example 1, Time Measurement:** This example explains how to measure the time of one-half cycle of the calibrator square-wave output. Set the Type 11B1 controls as outlined in Table 2-1.

TABLE 2-1

Typical Control Settings for Time Measurements

Control	Setting
TRIGGER MODE	AUTO LEVEL
TIME/CM	.1 mSEC
MAGNIFIER	.1 mSEC
SLOPE	(—)
COUPLING	AC
SOURCE	INT
VARIABLE	CALIB

With the controls set as outlined in Table 2-1, apply a 2-volt signal from the calibrator to the input of the vertical plug-in amplifier. Set the VOLTS/CM switch on the vertical plug-in for 4 cm of vertical deflection. Turn the vertical plug-in POSITION control until the vertical deflection extends 2 cm above and 2 cm below the horizontally-scribed centerline. Turn the HORIZ POSITION and VERNIER controls on

the oscilloscope until the 50% point on the positive half cycle of the square wave starts 3 cm from the left edge of the graticule. With the equipment properly calibrated, the 50% point on the trailing edge of the half-cycle occurs 5 cm to the right of the 50% point of the leading edge. Since the TIME/CM switch is set to .1 mSEC, the positive half cycle of the square wave is 0.5 msec long.

**Example 2, Risetime Check:** At the completion of the measurement listed in Example 1, unlock the MAGNIFIER knob by pulling it out, then, while holding it out, set it to the 2  $\mu$ SEC position. Using the HORIZ POSITION controls on the oscilloscope, position the leading edge of the positive half cycle at the vertically-scribed centerline. Using the HORIZ POSITION and VERNIER controls, carefully reposition the leading edge until the 10% point on the pulse crosses the horizontally-scribed centerline 2 minor graticule divisions up from the start of the pulse. If difficulty is encountered in positioning the pulse exactly, turn the TRIGGER MODE switch to MANUAL LEVEL and use the LEVEL control to move the leading edge. After the leading edge of the pulse is properly positioned, note the position of the 90% point of the rise. Since there is no easy point of reference from which to read, use the POSITION control of the vertical plug-in amplifier to move the 90% point down to the horizontally-scribed centerline. The 90% point will intersect the horizontally-scribed centerline less than one major graticule division to the right of the vertically-scribed centerline, thus providing a 10% to 90% risetime of less than 2  $\mu$ sec.

**Example 3, Type 11B1 Used as a Trigger Source:** Ordinarily, the signal to be displayed is also used to trigger the oscilloscope. In some instances, it may be desirable to reverse this situation. The sweep-related output pulses, available at the front panel of the Type 11B1, can be used as the input or triggering signal for external devices. The output signal of the external device will then produce a stable display while the oscilloscope free runs. For this type of operation, set the controls on the Type 11B1 as listed in Table 2-1 except set the TRIGGER MODE switch to FREE RUN. Connect the Type 11B1 +GATE OUT output to the external device to be triggered. Since the external device is now being triggered with a signal that has a fixed time relationship to the oscilloscope sweep, the output of the external device will produce a stable display on the oscilloscope, as though the oscilloscope were triggered in the normal manner.

**Example 4, External Horizontal Deflection:** For special applications, it is possible to produce horizontal deflection with an externally derived signal. This permits the oscilloscope system to be used to plot one function against another (e.g. Lissajous figures). However, the system is not intended for precise phase-angle measurements.

To use an external signal for horizontal deflection, connect the signal to the EXT TRIG OR HORIZ IN connector. Set the SOURCE switch to EXT and the TIME/CM OR HORIZONTAL VOLTS/CM switch to EXT HORIZ INPUT the signal can be either ac or dc coupled to the deflection amplifier by setting the COUPLING switch.

Sensitivity of the horizontal deflection system is changed by changing the MAGNIFIER switch when using external horizontal deflection. To change sensitivity, pull the MAGNIFIER knob out to unlock it, then set it to the selected position of the SEC OR EXT VOLTS positions. Setting the SOURCE switch to EXT  $\div$  10 decreases the horizontal deflection sensitivity by a factor of 10.

# SECTION 3

## CIRCUIT DESCRIPTION

### Introduction

This section contains the theory of operation of the various circuits in the Type 11B1. The discussions are supported by block diagrams inserted in the text and by the schematics in Section 5. The relationship of the circuits in each block to those in other portions of the system is discussed in the description of that block.

The block diagram in Fig. 3-1 shows the basic elements of the Type 11B1. The input signal is selected from three sources: internal from the plug-in vertical amplifier unit through the internal (INT) trigger preamplifier; a low voltage winding on the oscilloscope transformer (LINE); or from external sources (EXT TRIG OR HORIZ IN). The selected input signal is applied to the input cathode follower in the Trigger Generator circuit.

The output of the cathode follower is applied either to the Trigger Generator or directly to the Horizontal Pre-amplifier, depending upon the setting of the TIME/CM OR HORIZONTAL VOLTS/CM switch. The switching arrangement permits using any of the three inputs to provide horizontal deflection, or the input signal can be used to trigger the Sweep Generator which in turn provides an accurate time base for the horizontal sweep.

The input to the Horizontal Preamplifier is selected from the Sweep Generator or from the cathode follower in the Trigger Generator. The Horizontal Preamplifier splits the selected signal into a push-pull signal and applies it to the Horizontal Amplifier in the oscilloscope. The Horizontal Preamplifier also receives positioning voltages from the HORIZ POSITION control on the oscilloscope and applies a corresponding offset voltage to the push-pull output signal.

### Internal Trigger Preamplifier

The Internal Trigger Preamplifier (see schematic) consists of a push-pull driven, single-ended output, emitter coupled amplifier driving a complementary emitter follower. The

samples of the vertical deflection signal from the vertical amplifier plug-in units are applied to push-pull to the bases of transistors Q4 and Q14. If, for example, the signal increases the Q4 current, it decreases the current through Q14. Due to the common-emitter coupling, a current increase through Q4 compounds the current reduction in Q14. INT TRIG DC LEVEL R1 is adjusted during calibration so the "no signal" dc voltage delivered to the SOURCE switch is zero volts when the trace is vertically positioned near the center of the graticule.

The amplified triggering signal from the paraphase amplifier is applied to the base of Q23, and in slightly attenuated form, to the base of Q33. The combined function of Q23 and Q33 is that of an emitter follower, but this special configuration overcomes a common limitation of conventional emitter followers by providing equally fast response for both positive- and negative-going portions of a signal. The output signal is applied to the SOURCE switch.

The SOURCE switch selects the triggering signal either from the Internal Trigger Preamplifier, the line, or from the EXT TRIG OR HORIZ IN connector. High amplitude signals from the EXT TRIG OR HORIZ IN connector can be attenuated by setting the SOURCE switch to EXT  $\div$  10. In the EXT  $\div$  10 position, the externally applied signal is applied to a 10 $\times$  attenuator consisting of R28, R32, and R33. From the SOURCE switch, the selected signal is applied to the COUPLING switch.

In the AC position of the COUPLING switch, C30A, R32 and R33 provide a coupling time constant such that dc and very low-frequency ac signals are rejected. In the AC LF REJ position, the coupling time constant is decreased so that the ac rejection includes somewhat higher frequencies. This rejection is primarily intended to prevent triggering on the dc-level switching information encountered in alternate-trace operation of vertical plug-in units. The signal from the COUPLING switch is applied through a choice of coupling devices to the grid of cathode follower V43. Reed switch SW31 is included in the circuit to short out C31 if the TRIG-

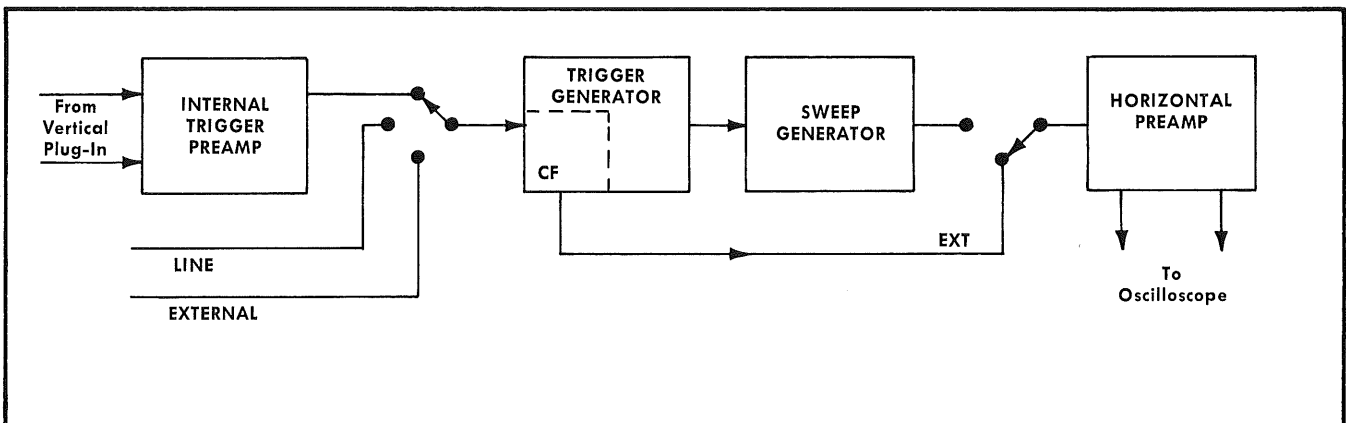

Fig. 3-1. Type 11B1 simplified block diagram.

## Circuit Description—Type 11B1

GER MODE switch is left in AUTO BASE LINE—AUTO LEVEL when the TIME/CM OR HORIZONTAL VOLTS/CM switches are positioned for external horizontal deflection. SW35 and SW36 are included to switch in a voltage divider when switching the TIME/CM OR HORIZONTAL VOLTS/CM to the EXT HORIZ INPUT position.

### Trigger Generator

For best triggering stability, the time-base generator requires trigger pulses that are representative of the triggering-signal frequency, but with greater wave-shape consistency than the signals generally encountered. The Trigger Generator converts the triggering signal into a pulse having a consistently fast risetime while retaining the characteristic repetition frequency of the triggering signal. The converted pulse is then used to trigger the time-base sweep. The block diagram in Fig. 3-2 shows the basic elements of the Trigger Generator.

The signal from the COUPLING switch and the coupling components is applied to the grid of cathode follower V43. D38 and D39 protect V43 from triggering signals of excessive amplitude. (V43 serves as an isolation stage when external horizontal deflection signals are used.)

The triggering signal from the cathode follower is applied to D43 and D46. D43, D46, R44, R45, R47, R48, and R49 operate in conjunction with the TIME/CM OR HORIZONTAL VOLTS/CM switch to route the signal to Q54 in the Trigger Generator or to Q303 in the Horizontal Preamp, depending upon the setting of the switch. When the switch is in the TIME/CM positions, the current flow through R43, D43, R44, and R49 (in conjunction with the —15 volts on R48) reverse biases D46 and prevents any

signal from passing through D46 and D47. If the switch is in the EXT HORIZ INPUT position, the current flow through R43, D46, D47, and R47, and R49 reverse biases D43 and prevents the signal from reaching the base of Q54.

Assuming that the TIME/CM OR HORIZONTAL VOLTS/CM switch is in the TIME/CM positions, the signal from V43 is applied via D43 to the base of Q54. Q54 and Q64 form a very sensitive current switch. If the instantaneous triggering signal voltage at the base of Q54 is more positive than the voltage established at the base of Q64 by the TRIGGERING LEVEL control and Q73, Q54 conducts. Unless the base voltages are very nearly equal, the two transistors cannot conduct at the same time due to the common-emitter coupling. Hence, as the positive-going portion of the triggering signal drives the base of Q54 from negative to positive (with respect to the base of Q64) the current through R54 switches from Q64 to Q54.

With the TRIGGER MODE switch set to AUTO BASE LINE—AUTO LEVEL, the voltages on the bases of Q54 and Q64 are close to being equal due to the base of Q73 being connected to the base of Q54 through D52 and R51. This eliminates the need for setting the TRIGGERING LEVEL control when making measurements in which the voltage level of the trigger point is not important.

When the SLOPE switch is set to +, D66 shunts R66 and raises the collector voltage of Q64 to the point where very little current can flow through D65. Current flow through R81 divides; part going through R80 and part through L85 and D85. The current flow through L85 and D85 is sufficient only to bias D85 to its low-voltage state (see Fig. 3-3). With the arrival of a positive trigger, Q54 is biased into conduction, cutting off Q64 and forward biasing D55. The current flow through D55 flows through R80, increasing the voltage

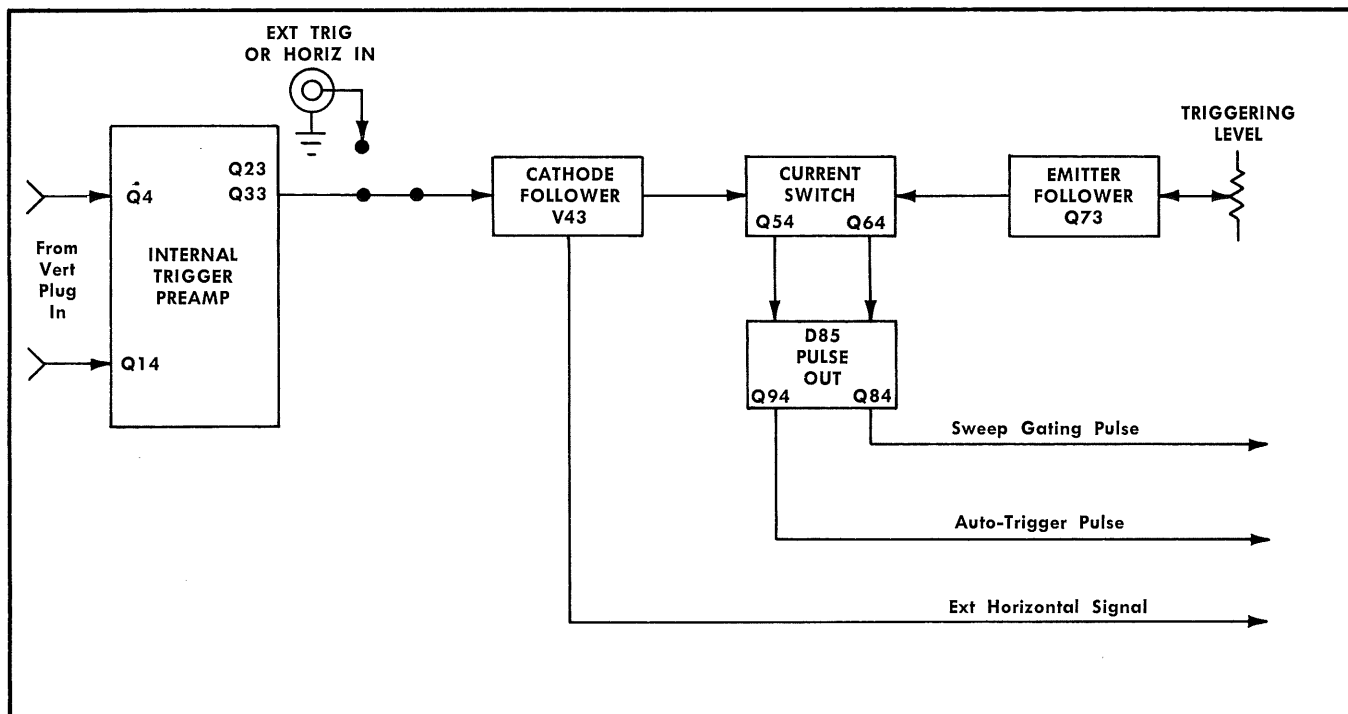

Fig. 3-2. Trigger Generator simplified block diagram.



drop across R80. The resulting decrease in current flow through D80 makes more current available for D85, and D85 switches to its high-voltage state. The switching of D85 causes a sudden increase in the conduction of Q84. The increase in current through Q84 sends a trigger pulse to sweep-gating tunnel diode D135, and in addition, biases Q94 into heavier conduction, which sends a trigger pulse to the automatic trigger circuit.

If the SLOPE switch is set to —, D56 shunts R56. Q64 is kept cut off by the conduction of Q54. The arrival of a negative-going signal cuts off Q54 and permits Q64 to conduct. The conduction of Q64 through D65 and R80 reduces the current flow through D80. The decreased current flow through D80 makes more of the current flow through R81 available to tunnel diode D85, and D85 switches to its high-voltage state as previously explained.

As is characteristic of a tunnel diode, the transition from the low-voltage state to the high-voltage state occurs very rapidly, no matter how slowly the current increases (see Fig. 3-3). Therefore, this switching action of the tunnel diode provides the base of Q84 with a fast-rise negative-going pulse.

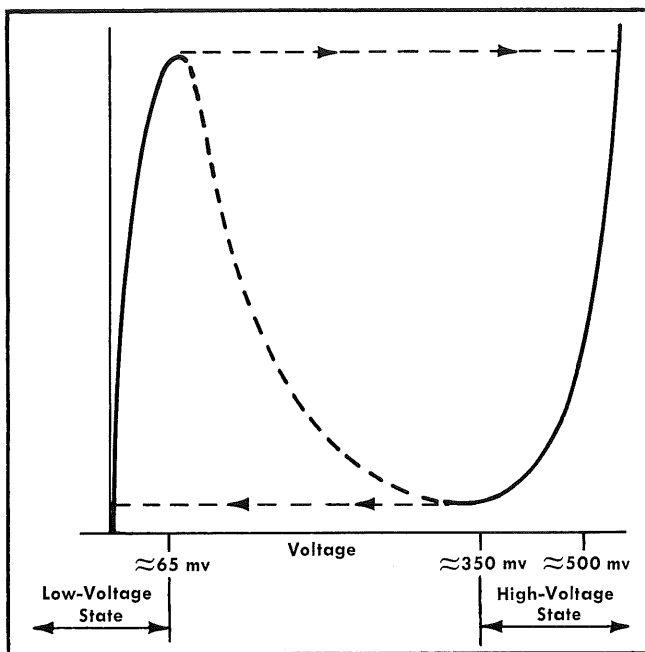

Fig. 3-3. Tunnel diode characteristics.

The steady state current of Q84 passes through the high resistance of R84. When the tunnel diode suddenly drives the base of Q84 negative, the very fast rise of the pulse forces Q84 to draw upon the charge of C83 to supply the sudden current demand. Since the time constant of C83 and its charge path are very short, the change in the charge on C83 is accomplished very quickly, and the current through Q84 decays very rapidly to a steady state value, even though the tunnel diode may remain in its high-voltage state.

When the triggering signal resets the tunnel diode to its low-voltage state, Q84 turns off, but rapidly recovers to its steady-state conduction level. The output pulses produced at

reset are insignificant and have no effect on the Sweep Generator.

## Sweep Generator

The Sweep Generator (see Fig 3-4) produces four simultaneous output signals:

1. A positive-going sawtooth that is applied to the Horizontal Preamplifier by setting the TIME/CM OR HORIZONTAL VOLTS/CM switch to any of the TIME/CM positions. The positive-going sawtooth is also available for external use at the SWEEP OUT front-panel connector.
2. A negative-going crt unblanking pulse with the same duration as the sweep sawtooth rise. This pulse is coupled to the oscilloscope crt when the TIME/CM OR HORIZONTAL VOLTS/CM switch is set to any of the TIME/CM positions.
3. A positive-going pulse with the same duration as the sawtooth rise. This pulse is coupled to the front-panel + GATE OUT connector for external use.
4. A negative-going multi-trace sync pulse occurring at the end of the sweep-sawtooth rise. This pulse is coupled to the vertical plug-in unit interconnecting socket. The pulse is used to switch channels in a multi-trace plug-in unit when operating in the alternate mode.

In most applications, each cycle of events is started by a trigger pulse from the Trigger Generator. However, it is also possible to free run the Sweep Generator; that is, the end of one cycle causes the next cycle to begin. The desired operation is selected by the TRIGGER MODE switch. The five operating modes provided by the TRIGGER MODE switch are described in Section 2 of this manual.

The Sweep Gating Multi (see Fig. 3-4) is an electronic switch that drives the Gate Amplifier to turn the Disconnect Diode on and off. When the Disconnect Diode is switched off, the Miller Runup Integrator begins to produce a sawtooth signal. A sample of the sawtooth is fed back to the Gate Enable Multi to reset the Sweep Gating Multi when the sawtooth reaches a certain amplitude. As the Sweep Gating Multi resets, the Disconnect Diode is switched on, and the Miller Runup resets to form the retrace or falling portion of the sawtooth. Following a short stabilization period, the Sweep Generator is ready to repeat the sequence.

The TRIGGER MODE switch provides five ways to switch the Sweep Gating Multi so that the sweep begins:

1. In NORM, the multi is switched by a pulse from the Trigger Generator.
2. In SINGLE SWEEP, two pulses are required to start **each** sweep. First, a pulse from the Reset Amplifier (originating at the RESET pushbutton or from an external device through pin F of J101 on the rear panel of the oscilloscope) resets the Gate Enable Multi. Then, after reset, the Sweep Gating Multi can be switched by a pulse from the Trigger Generator.
3. FREE RUN results in recurrent sweeps that are independent of any triggering signal. The retrace portion of one sawtooth switches the multi to begin the next sawtooth.

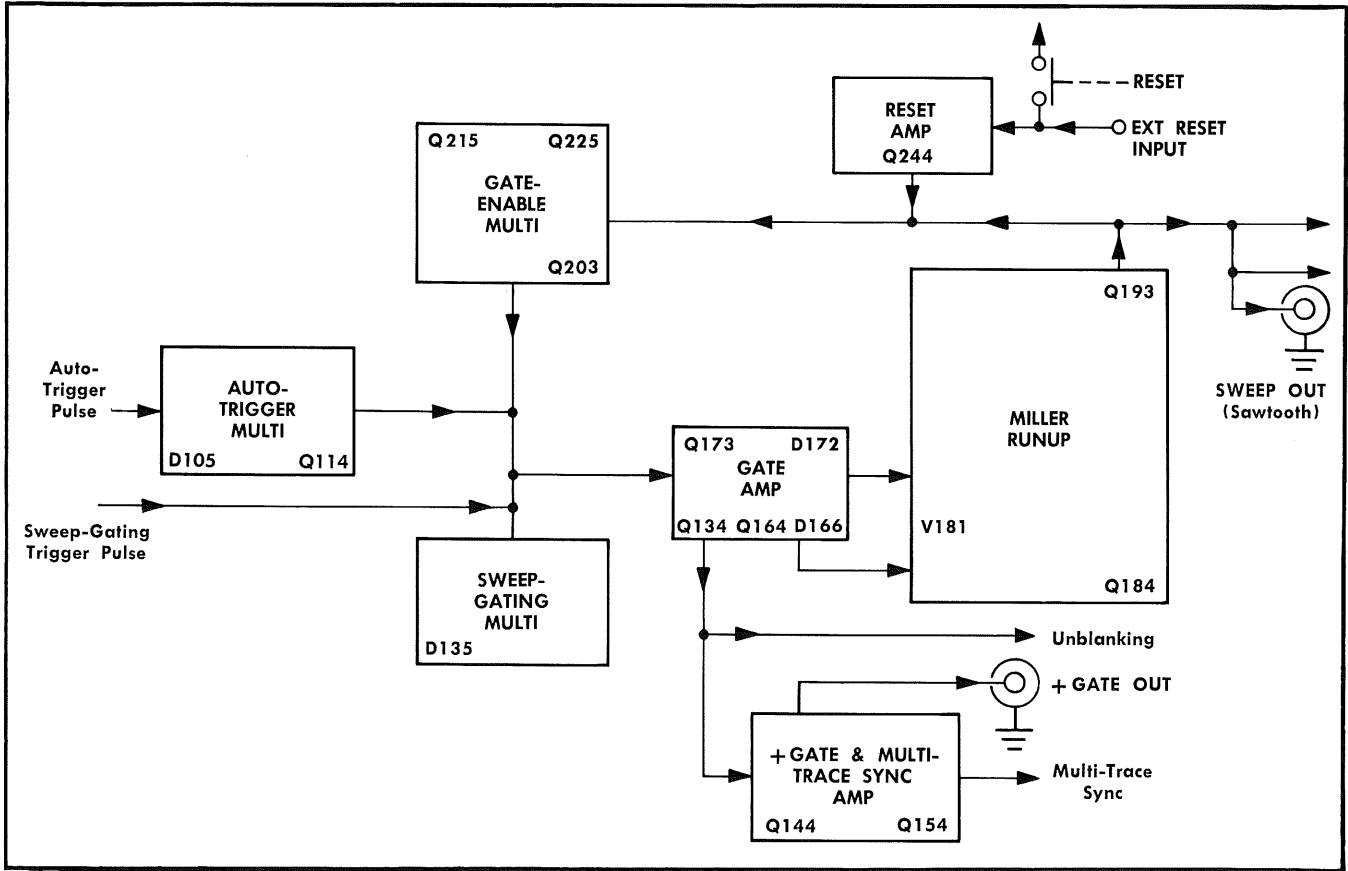

Fig. 3-4. Sweep Generator block diagram.

4. The AUTO BASE LINE—MANUAL LEVEL position is a combination of NORM and FREE RUN. If there are no trigger pulses coming from the Trigger Generator, the Auto Trigger Multi permits the sweep gating circuit to "free run". When a pulse comes from the Trigger Generator, the Auto-Trigger Multi switches the sweep gating circuit to the "normal" condition, but this first trigger pulse does not start a sweep. If the first trigger pulse is followed by a second within about 80 msec, the sweep gating circuit switches and a sweep begins. If trigger pulses continue to arrive very 80 msec or less, the Auto Trigger Multi remains in the "normal" condition and each sweep is a triggered sweep. Whenever the period between trigger pulses exceeds 80 msec, the Auto Trigger Multi reverts to the free-run condition until the next trigger-pulse arrives.
5. Operation in the AUTO BASE LINE—AUTO LEVEL position is the same as the operation in the AUTO BASE LINE—MANUAL LEVEL position, except that it is unnecessary to adjust the LEVEL control to trigger the time base with the triggering signal if the triggering signal is a low duty-cycle, negative-going pulse of about 1 cm or more in amplitude.

The following discussion is based on the Sweep Generator schematic in Section 6. The first part of the discussion pertains to operation with the TRIGGER MODE switch set to NORM.

**Quiescent Conditions.** In the quiescent state; that is, when the sweep generator is triggerable but no sweep is being generated, the circuit conditions are as follows:

Q225 is conducting and Q215 is cut off. Q225 establishes current through the parallel arrangement of D135, D131, and D122. Tunnel diode D135 is in the low-voltage state (see Fig. 3-3) so that Q134 is cut off. With Q134 cut off, its collector voltage goes positive and forward biases Q164 and Q173. The conduction of Q164 forward biases Disconnect Diode D166.

The conduction of Q164 through R134, R136, R173, R171, and R164 produces about +6.5 volts at the collector of Q134. This voltage is divided to about zero volts by R401 and R403 in the unblanking circuit (see Interconnecting Plug schematic). Q144 is conducting heavily, but its collector and the +GATE OUT connector output are clamped at about -0.6 volt by D144. Q154 is cut off and the voltage on the multi-trace sync-pulse bus is about +5 volts.

With Disconnect Diode D166 conducting, the grid of V183 is clamped at about zero volts. D172 and Q173 form a servo loop with the Miller Integrator circuit which clamps the sawtooth output bus at about +2.4 volts to provide a stable, repeatable sawtooth starting voltage.

V183, Q181, and Q193 form a Miller Runup Integrator. The tube and transistors are clamped at moderate conduction levels by D166, D172, Q173, and Q164. The Q193

emitter voltage is about +1.8 volts, forward biasing D200 and D201. Q203 conducts heavily and reverse biases D203. Q225 is held on by the divider consisting of R232, R231, R229, R215 and R216.

**NORM Mode Operating Cycle.** With the TRIGGER MODE switch set to NORM, Q114 has no collector supply and the Auto Trigger Multi is disabled. A sweep gating trigger pulse turns on D130 and turns off D131. The current through Q225 does not decrease when D131 cuts off, but is transferred instead to tunnel diode D135, rapidly switching it to its high-voltage state.

When the tunnel diode switches, Q134 turns on. The negative voltage step at the collector of Q134 provides the oscilloscope crt unblanking pulse. Q144 is cut off by the negative step, forming the rise of the +GATE OUT signal. Q154 remains cut off.

The negative-going voltage step at the collector of Q134 is applied to the emitter of Q164, turning the transistor off. Thus, Disconnect Diode D166 is rapidly switched off.

When the Disconnect Diode (D166) turns off, the current through timing resistor  $R_t$  does not cease, but instead begins to charge timing capacitor  $C_t$ . As the timing capacitor charges, the grid of V183 goes negative. The inverted and greatly amplified change at the collector of Q181 is fed back to the timing capacitor and opposes the grid voltage change. (The positive-going change also turns off D172.) This action persists throughout the sawtooth period and limits the total grid voltage change to less than 0.1 volt. Since the voltage drop across the timing resistor is held nearly constant, the current through the resistor is essentially a fixed value. This fixed current flows into the timing capacitor, producing a linearly increasing voltage (sawtooth) across the capacitor. D166 is a special diode that exhibits very low leakage under reverse-bias conditions. This characteristic prevents the diode from effectively altering the timing resistance value.

The rate of the sawtooth rise is a function of the RC time constant of the timing resistor and capacitor, and of the voltage magnitude at the negative end of the timing resistor. Increasing the voltage across the timing resistor increases the current into the timing capacitor and therefore increases the sawtooth rate of rise. The voltage across the timing resistor can be varied over about a 9-volt range by adjusting SWP CAL R180W shown on the Timing Switch schematic. R180W is adjusted during calibration to establish the correct absolute rate of sawtooth rise and effects all sweep rates equally.

The VARIABLE front-panel control operates in much the same manner as the SWP CAL control, but permits the operator to obtain uncalibrated sweep rates as much as two and one-half times slower than the calibrated rates obtained with the control set fully clockwise.

The sawtooth signal at the collector of Q181 is available to the Horizontal Pre-amplifier through the TIME/CM OR HORIZONTAL VOLTS/CM switch and is applied also to the base of Q193. The rising voltage at the emitter of Q193 supplies the front-panel SWEEP OUT connector output signal and charges holdoff capacitor  $C_{ho}$  through D200 and D201. As the holdoff capacitor charges, the base and emitter of Q203 go more positive. D203 becomes forward biased and the positive-going change at the emitter of Q203 drives the

base of Q225 more positive. As the positive-going base voltage of Q225 equals and then surpasses the base voltage of Q215, the current through R225 switches regeneratively from Q225 to Q215.

When Q225 turns off, tunnel diode D135 reverts to its low-voltage state. The time duration of the sweep-gating trigger pulse, which started the cycle of operation is always considerably less than the time duration of the sweep. However, once the sweep-gating pulse switches the tunnel diode to its high-voltage state, additional trigger pulses can have no further effect on the operation (see Fig. 3-3). The tunnel diode reverts to its low-voltage state only when Q225 turns off.

As the tunnel diode reverts to its low-voltage state, Q134 turns off. The collector voltage of Q134 rises, blanking the oscilloscope crt. Q144 turns on, forming the falling portion of the +GATE OUT connector output signal and driving Q154 into conduction. C149 quickly discharges and Q154 again turns off. Thus, the multi-trace sync pulse is negative-going and has a very short duration.

The positive-going step at the collector of Q134 turns on Q164, forward biasing Disconnect Diode D166. Since the timing capacitor still holds the charge developed during the sweep, D172 remains back biased. The timing capacitor begins to discharge through D166, Q164, and the series-parallel combination of R134, R136, R161, and R173. D172 does not conduct until the charge is nearly depleted.

The removal of the timing capacitor charge forms the retrace or falling portion of the output sawtooth. As the emitter voltage of Q193 falls, D200 becomes back biased. During the sawtooth rise, hold-off capacitor  $C_{ho}$  charges through D200 and D201, but now must discharge through the high resistance of R200 and R201. Thus, timing capacitor  $C_t$  will have discharged, restoring the Miller Runup circuit to its quiescent condition before the base voltage of Q203 reaches its quiescent level. This time lag can be varied slightly by adjusting the front-panel HF STABILITY control. The need for this variable time lag is discussed in a later paragraph.

As the hold-off capacitor discharges, the emitter voltage of Q203 falls. However, this falling voltage does not immediately cause the current through R225 to switch to Q225. The voltage drop across R215 and R216, produced by the conduction of Q215, is divided by R232, R231, and R229 and keeps Q225 cut off. When the emitter voltage of Q203 becomes low enough to forward bias D213, the added current through R232, R231, R229, and R215 pulls down the base voltage of Q225 and switches the current through R225 and Q225. The entire sweep generator is then restored to the quiescent condition previously described.

HF STABILITY R201 permits the operator to vary slightly the time between the completion of a sweep and the instant when the sweep generator again becomes triggerable. As Q225 turns on after a sawtooth retrace, a very short but sometimes significant amount of time is required for the current through tunnel diode D135 to reach the quiescent level. This recovery time is significant only under the following conditions:

1. When the sweep rate is faster than about 0.2  $\mu\text{sec/cm}$  (unmagnified).
2. When the triggering frequency is above about 5 mc.

### Circuit Description—Type 11B1

- When the relationship between the sweep rate and triggering frequency is such that the sweep-gating trigger pulse tends to trigger each new sweep while the tunnel diode current is approaching the quiescent level.

A display obtained under these conditions may jitter horizontally. The operator can minimize and often eliminate the jitter by resetting the HF STABILITY control. This either advances or delays the turn-on time of Q225 so that D135 can stabilize at the quiescent level in the interval between sweep-gating trigger pulses.

**FREE RUN Mode.** The FREE RUN mode of operation differs from the NORM mode as follows:

When the TRIGGER MODE switch is set to FREE RUN, R122 is connected to +15 volts and D122 is reverse biased. The current through Q225, carried by D122 in NORM operation, is now carried by tunnel diode D135. As Q225 turns on following a sawtooth retrace, D135 switches to its high-voltage state without waiting for a sweep-gating trigger pulse (moreover, at low sweep speeds the trigger pulses have no effect on the overall operation). Thus, the completion of one sweep causes the next to begin.

**AUTO Mode.** The basic operation of the Auto Trigger Multi was described previously in the Sweep Generator block diagram discussion. The conduction state of the Auto Trigger Multi determines whether D122 is forward biased or

reverse biased. When forward biased, the Sweep Generator operates exactly as described for the NORM mode. When D122 is reverse biased, the Sweep Generator operates as described for the FREE RUN mode.

When C102 has received no trigger pulse for more than 80 msec, tunnel diode D105 goes to its high-voltage state (see Fig. 3-3) and Q114 is turned off. D114 conducts through R116, reverse biasing D122, and the Sweep Generator free runs. The current paths, static current magnitude, and voltages with the circuit in this condition are shown in Fig. 3-5.

The first portion of the following discussion describes the sequence of events caused by a single auto-trigger pulse. The only effect of such a pulse would be an interruption of the free-running sweeps. The latter portion of the discussion describes how triggered sweeps are produced by triggering signal occurring more often than every 80 msec.

When a current pulse is applied to C102, D102 conducts by diverting current from tunnel diode D105. The tunnel diode rapidly switches to its low-voltage state, driving Q114 into saturation. The collector of Q114 drops to about -14 volts, reverse biasing D114, and D122 turns on. (D122 may turn on while a "free-run initiated" sweep is in progress. If this occurs, the Sweep Generator will complete the sweep and become triggerable at the end of the usual sweep hold-off period.)

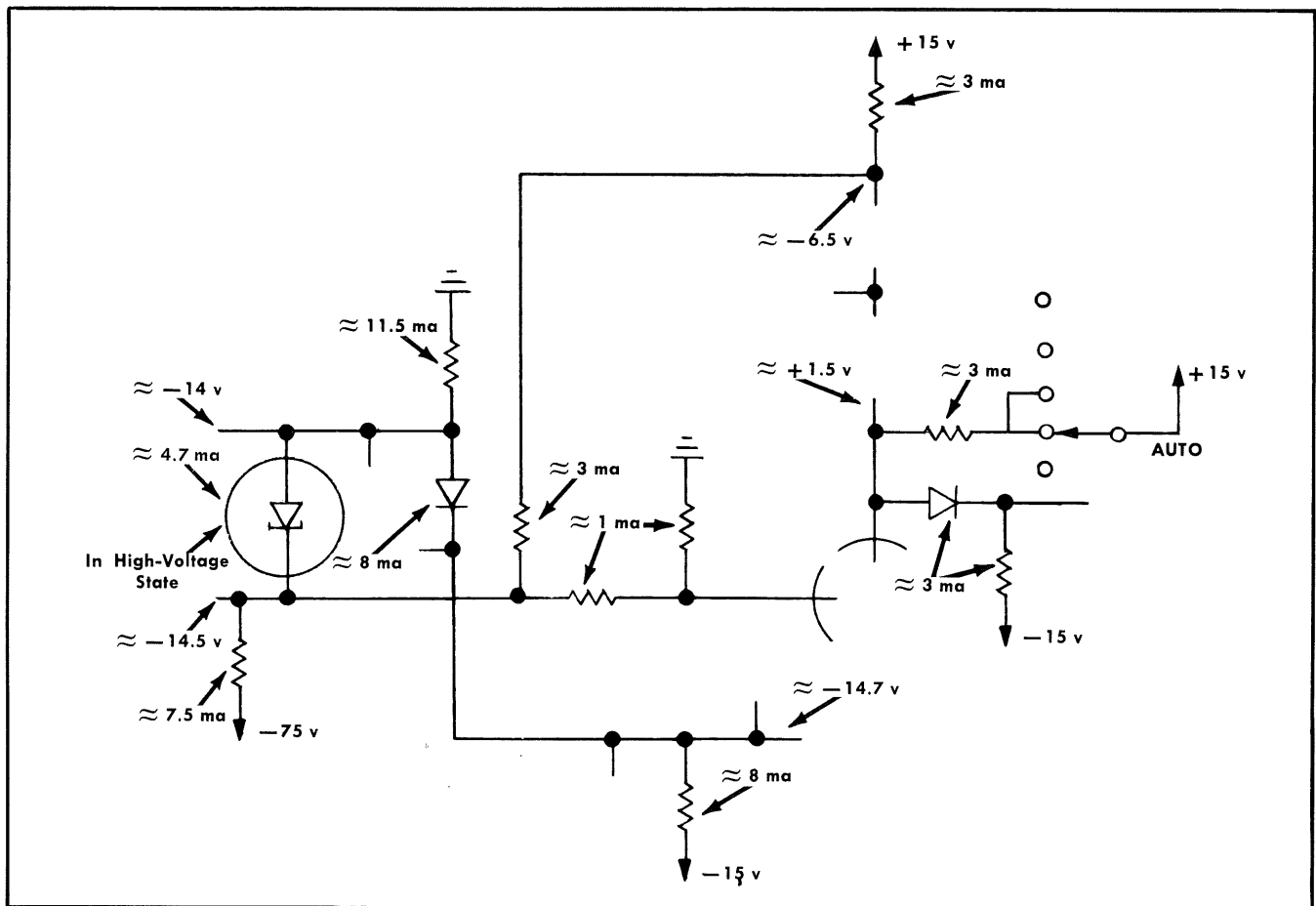

Fig. 3-5. Auto Trigger Multi static conditions.

As Q114 goes into saturation, the greater portion of its collector current passes through R114 and begins to discharge C114. The voltage across C114 decreases and D113 begins to conduct, decreasing the current through R112. The current through R106, no longer carried by R112, is diverted to tunnel diode D105, switching it to its high-voltage state. (By this time, the auto-trigger pulse current through D102 has subsided.) Q114 turns off, but C114 must recharge before the collector voltage of Q113 can rise. Hence, D114 remains off and D122 remains on.

As Q114 turns off, C114 begins to charge through R114 and R116 in parallel with R113. When the voltage at the junction of C114 and R114 reaches about  $-7$  volts, D113 turns off and C114 continues to charge through R114 and R116. D114 becomes forward biased when the collector of Q114 reaches about zero volts. D122 then cuts off and the Sweep Generator returns to its free-running condition.

As previously stated, the Auto Trigger Multi probably will turn on D122 while a free-run initiated sweep is in progress. If this happens, the sweep generator cannot become triggerable until the end of the hold-off period for this sweep, but from then on, every sweep is a triggered sweep if the repetition rate of the auto-trigger and sweep-gating trigger pulses is greater than about 20 pulses/sec.

If an auto-trigger pulse arrives at C102 after tunnel diode D105 has reset to its high state, but before C114 has completely recharged, D105 again switches to its low state. Q114 turns on and discharges the partially recharged C114

as discussed previously. Additional auto-trigger pulses that arrive while the tunnel diode is in its low state have no significant effect on the circuit. Pulses that arrive while the tunnel diode is in its high state switch the diode back to its low state if the current through D113 has decreased sufficiently. Thus auto-trigger pulses with a repetition rate greater than about 20 pulses/sec will repeatedly switch the multi, preventing C114 from charging enough to turn on D114. With D114 turned off continuously, the Sweep Generator operates exactly as it does in the NORM mode.

**SINGLE SWEEP Mode.** As described previously in the NORM mode discussion, the retrace portion of a sawtooth normally allows discharging hold-off capacitor  $C_{ho}$  to pull down the base voltage of Q203 to near zero volts. D213 then conducts and turns on Q225. However, in the SINGLE SWEEP mode, R202 is connected to  $+15$  volts, forming a divider with R200 and R201. This divider stops the hold-off capacitor discharge at about  $+4.5$  volts. Under these conditions, the emitter of Q203 does not drop far enough to cause D213 to conduct, and Q225 cannot turn on. D200 is reverse biased and D201, in series with the divider, remains on.

Since Q225 does not turn on following a sweep, the Sweep Generator is locked in an inoperative state. With Q215 on, Q234 is held cut off and RESET lamp B234 remains unlit, indicating the inoperative state of the Sweep Generator. The Sweep Generator can be reset to the operative state either by pressing the RESET button or by applying

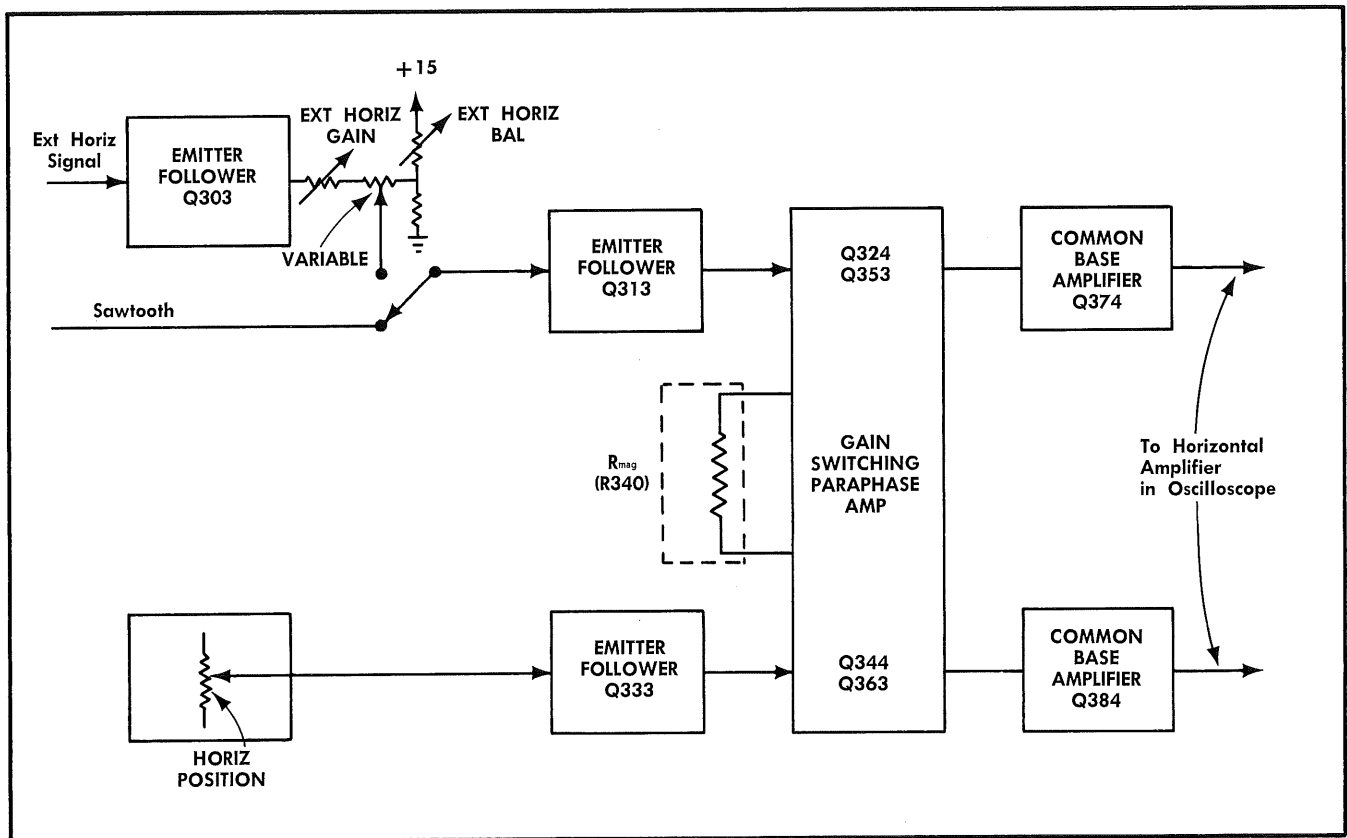

Fig. 3-6. Horizontal Preamp simplified block diagram.

## Circuit Description—Type 11B1

a positive-going pulse to pin F of J101 on the rear panel of the oscilloscope. Externally applied pulses must have a reasonably fast rise for adequate energy to pass through C204.

In SINGLE SWEEP mode, Q244 is normally off. The RESET button is connected to a divider consisting of R238 and R239. When the RESET button is pressed, neon lamp B241 fires, supplying a fast-rise turn-on pulse to Q244. The negative-going pulse at the collector of Q244 is applied to the base of Q203. (At this time, D200 serves its only purpose: it is reverse biased by the pulse so that the hold-off capacitor will not pass the pulse to ground.) The pulse pulls down the emitter of Q203 and turns on D213. Q225 and Q234 turn on and RESET lamp B234 lights to indicate that the Sweep Generator is ready to be triggered. At the end of one conventionally-triggered sweep, the generator again becomes inoperative.

### Horizontal Preampifier

The block diagram in Fig. 3-6 shows the basic subcircuits of the Horizontal Preampifier. The input signal is selected from the Sweep Generator or from an external source, depending on the setting of the TIME/CM OR HORIZONTAL VOLTS/CM switch. The push-pull output of the preampifier connects to the input of the oscilloscope horizontal amplifier through pins 8 and 9 of the inter-connecting plug. Gain of the preampifier may be increased up to 50 times by setting the MAGNIFIER switch as described in Section 2.

Emitter follower Q303 provides a high-impedance load for cathode follower V43 in the trigger generator whenever the TIME/CM OR HORIZONTAL VOLTS/CM switch is placed in the EXT HORIZ INPUT position. The output of Q303 is applied to the TIME/CM OR HORIZONTAL VOLTS/CM switch. The input to Q313 is the external deflection signal from Q303 or the sawtooth from the Sweep Generator, depending on the setting of the TIME/CM OR HORIZONTAL VOLTS/CM switch. Q333 couples the horizontal positioning voltage to Q344 and provides a low source impedance.

Refer to the Horizontal Preampifier schematic in Section 6. The following explanation of circuit operation assumes that

the Horizontal Preampifier input signal is the sawtooth from the Sweep Generator.

The sawtooth applied to Q313 swings symmetrically around approximately +8 volts, rising from about +3 to +13 volts. The oscilloscope HORIZ POSITION controls provide a means of varying the base voltage of emitter follower Q333 from about zero volts to about +15 volts. The output of Q333 is applied to the base of Q344, providing a range of adjustment that exceeds peak voltages of the sawtooth at the base of Q324.

Transistors Q324, Q353, Q344 and Q363 form a paraphase amplifier with degenerative emitter coupling through  $R_{mag}$ . The two transistors in each side of the paraphase are compound connected to achieve the high effective gain needed to make the stage gain dependent only upon the coupling resistor (R340). Feedforward resistors D355 and D365 feed signals around each half of the paraphase amplifier stage to cancel the signal current generated in the stage due to the supply-return resistors R321 and R341. This cancellation has two beneficial effects: (1) it eliminates any common-mode current at the stage output even though the stage is driven single-ended, and (2) it makes the gain of the stage exactly proportional to the conductance of  $R_{mag}$ .  $R_{mag}$  is about 2.5 k when no magnification is used ( $\times 1$ ) and is decreased to about  $50 \Omega$  for  $50 \times$  magnification.

Diodes D324 and D349 and resistor R343 provide the amplifier with a self-limiting feature which prevents transistors Q363 and Q384 from becoming cut off when sweep voltages reach left-of-screen values. When the paraphase amplifier is overdriven in the left-of-screen direction by a signal equivalent to about 10 cm left of center, diode D349 begins to conduct, cutting off transistor Q344. The remainder of the amplifier now remains in a static condition, but with the capability of achieving a fast recovery and generating the necessary linear sweep output even when driven-on screen at the fastest sweep rates.

The output signals from the paraphase amplifier are applied to common-base stage Q374 and Q384. The collectors of Q374 and Q384 are near ground potential and connect to the low-impedance input of the oscilloscope horizontal amplifier. Because of this low input impedance, the Type 11B1 Horizontal Preampifier provides a current output at essentially a fixed voltage.

## TYPE 11B1 BLOCK STUDY

The Type 11B1 is a high performance single time-base for the Type 647 oscilloscope, with a direct reading X1 to X50 sweep magnifier. Figure 1 is the block diagram.

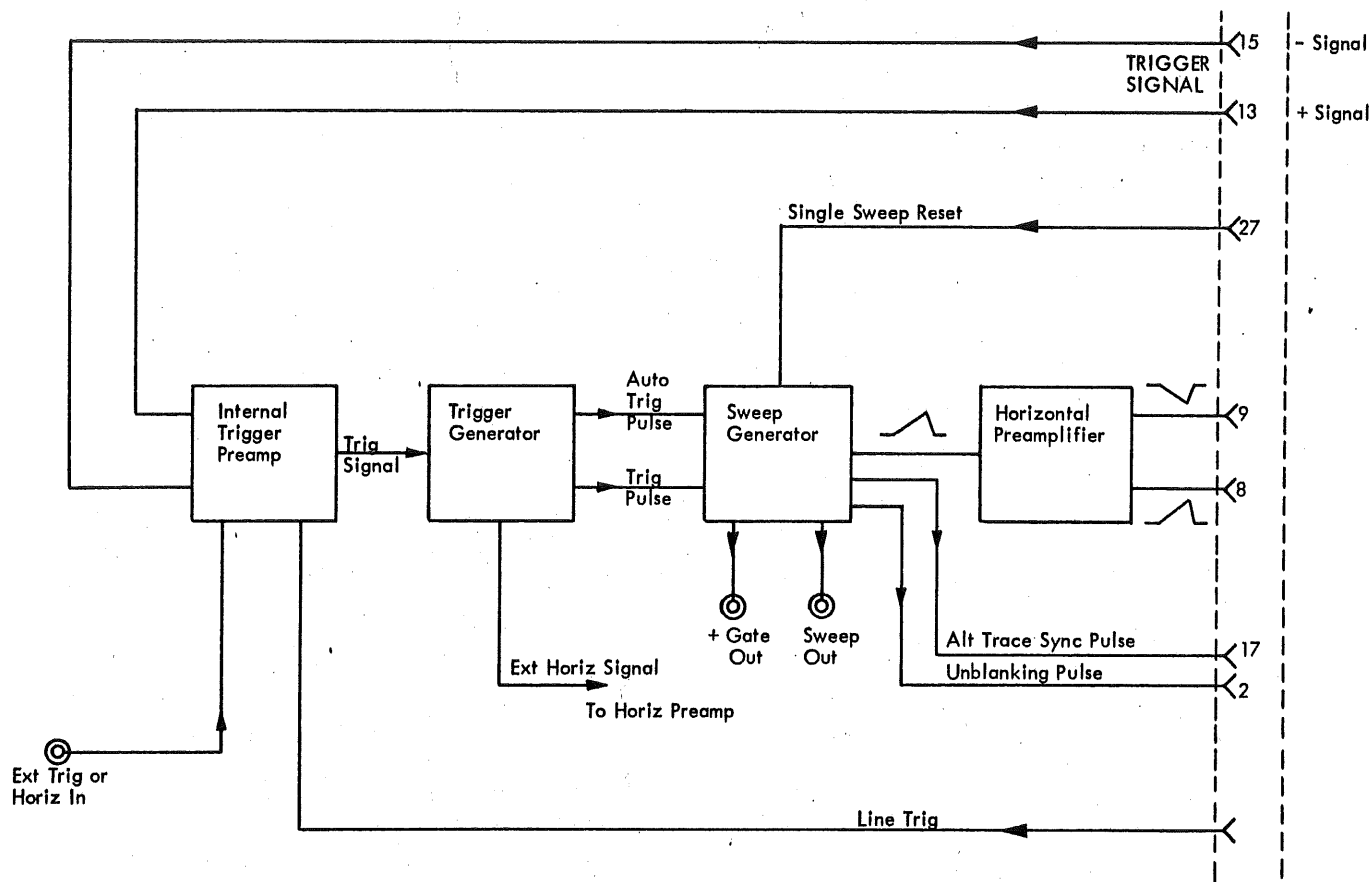

11B1 BLOCK DIAGRAM

Figure 1

The Time-Base generator has 24 calibrated sweep rates, from 2 seconds/cm to 0.1 microseconds/cm. In addition, the sweep rate of the time base is independently variable over a range of about 2.5 to 1. A new "direct reading" magnifier of X1 to X50 that indicates directly the magnified time/cm rate is included in the Type 11B1. The actual magnification steps are X1-2-5-10-20-50, X1-2.5-5-10-25-50 or X1-2-4-10-20-40, depending on the time/cm to be magnified. The fastest magnified sweep rate is 10 nsec/cm.

The Trigger Circuit allows the time base to be triggered by:

1. Internal Signal
2. External
3. External  $\div 10$
4. Line Frequency

Coupling of the triggering signal can be either AC, AC LF REJ, or DC with triggering on either the plus or minus slope.

The Time Base can operate in a variety of triggering modes.

1. Single Sweep: This mode allows the sweep to operate only once, triggered by the triggering signal. Before the time base can operate again, the circuit must be armed. This is accomplished by pressing the RESET button or by applying an external signal to pin 1 of J101 on the 647 oscilloscope.
2. NORMAL: This position operates in the usual manner where the triggering signals initiates the start of the sweeps.
3. AUTO MANUAL LEVEL: In the absence of a triggering signal, the sweep is allowed to free run. Stable triggering occurs when the normal triggering signals have a faster repetition rate than about 20 cps. Selection of the triggering level is provided.
4. AUTO PRESET LEVEL: This mode is identical to the AUTO MANUAL LEVEL except the triggering signal is AC coupled and the triggering level is predetermined (LEVEL control inoperative).
5. FREE RUN: Triggering signals take no part in the operation of the sweep generator. The sweep generator operates continuously.



## I. INTERNAL TRIGGER PREAMPLIFIER

Following is the block diagram of the internal trigger preamplifier.

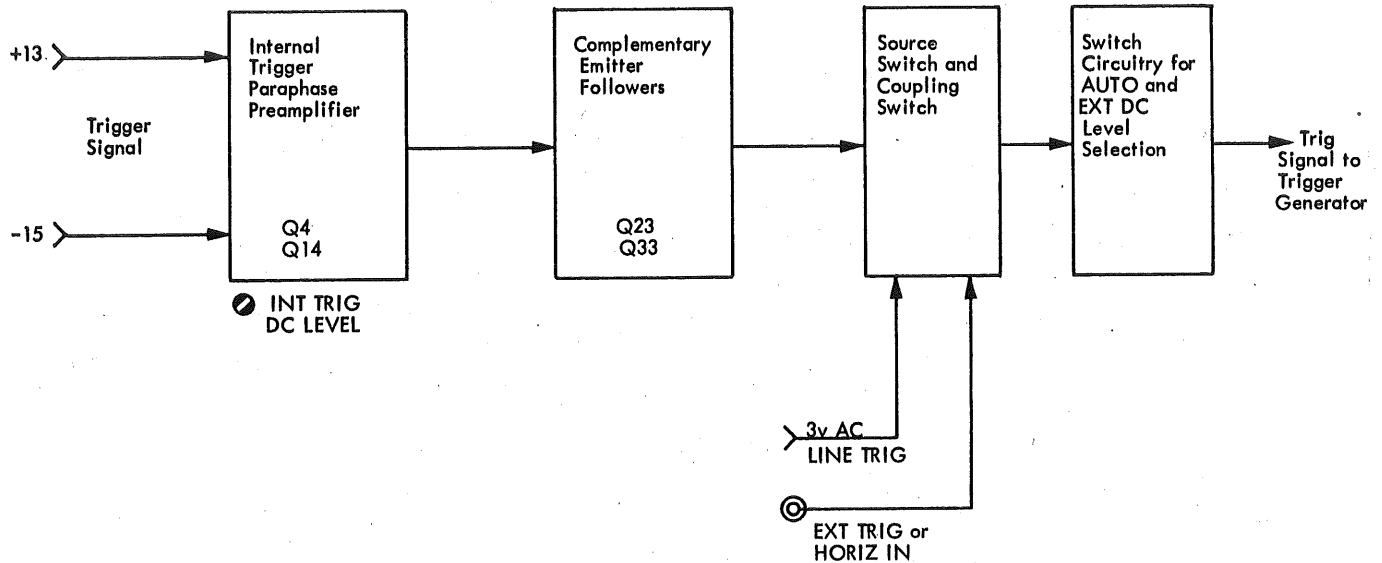

11B1 INTERNAL TRIGGER PREAMP BLOCK DIAGRAM

Figure 2

The internal trigger signal from the vertical plug-in is fed through the interconnecting wiring in the Type 647 to the internal trigger preamplifier of the Type 11B1. The internal paraphase amplifier converts the triggering signal from double-ended to single-ended. The output is fed to the emitter followers. This output is then fed to the SOURCE and COUPLING SWITCHES and on to the switch circuitry for selection of the DC level in the AUTO mode of operation.

### A. INT TRIG PARAPHASE AMPLIFIER

Figure 3 is the simplified schematic.

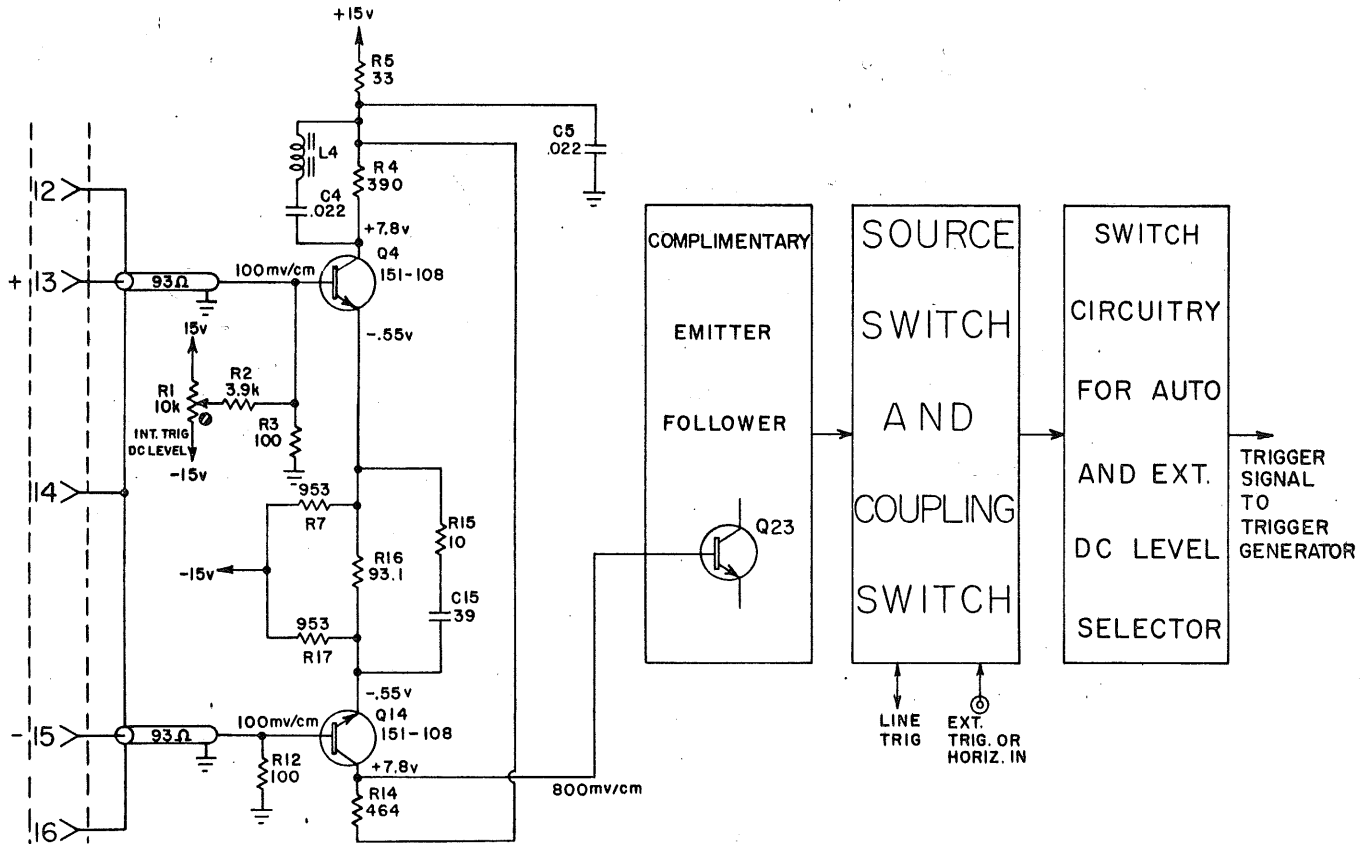

TYPE IIB1 INTERNAL TRIGGER PREAMPLIFIER  
INTERNAL TRIG. PARAPHASE PREAMP  
Fig. 3

B-11B1-0001x  
1-2-64 jg

The circuit consists of a push-pull transistor amplifier (151-108 transistors) driving a complementary pair of emitter followers. The triggering signal from the vertical amplifier passes from the vertical blue ribbon connector, through the 647, and appears on pins 13 and 15 of the 11B1 connector. The adjacent blue ribbon connectors, pins 12, 14 and 16, are grounded providing uniform shielding and effectively extending the 93Ω transmission line into the connector. The 93Ω transmission lines are terminated at the bases of Q4 and Q14 in 100Ω (R3 and R12) in parallel with the emitter to base resistances. Signal levels at the connectors are 100 mv/cm for each side.

Q4 and Q14 convert the push-pull input signal to a single-ended output signal at the collector of Q14. One of the reasons for using single-ended circuit in the trigger circuit is that DC stability is much easier to obtain than with a push-pull system. One might ask, "Why not use a single-ended signal from the vertical?" The signal is already push-pull in the vertical and to provide for cancellation of common mode signals that might be picked up between the vertical and triggering circuit, a push-pull stage was used (Q4 and Q14) in the 11B1.

The signal level at Q14 collector is approximately 800 mv/cm. R4 is to promote thermal balance between the push-pull pair. It is necessary to prevent drift in Internal DC triggering point if you have a wave whose duty cycle is constantly changing. The swinging collector of Q4 would give capacitive feedback to the base, and hurt transient response. C4 prevents this. However, with C4 in place, Q4 will oscillate when the input is high enough to cut off Q14. This can be prevented by inserting a lossy device in series with C4. A 10 $\Omega$  resistor would work; the ferrite bead (L4) is easier.

The INT TRIG DC LEVEL adjustment (R1) assures zero volts at the output of the complementary emitter follower with zero volts present at the inputs to Q4 and Q14.

Quiescent levels, Q4 - Q14:

- a. Q14, Q4 Bases, 0v.
- b. Q14, Q4 Emitters, -.55v.
- c. Q14, Q4 Collectors, 7.8v.

### B. COMPLEMENTARY EMITTER FOLLOWER

Figure 4 is the simplified schematic.

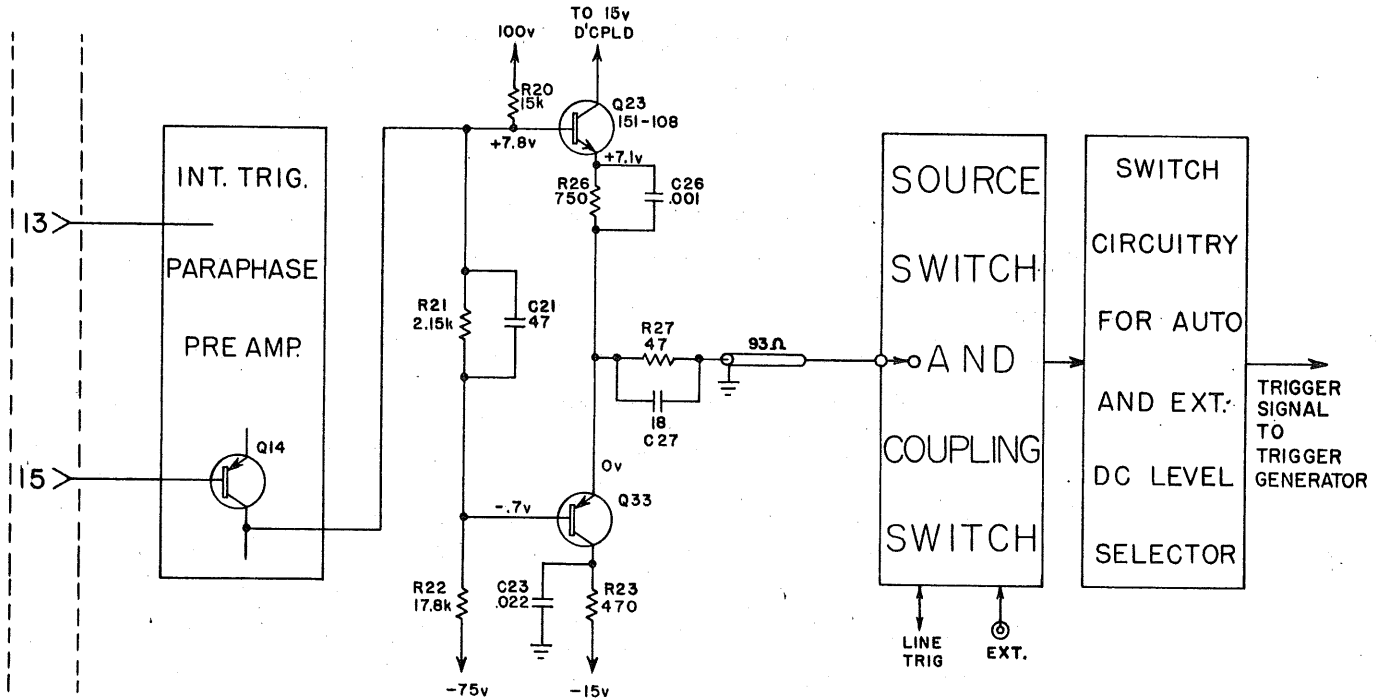

TYPE IIB1 INTERNAL TRIGGER PREAMPLIFIER  
COMPLIMENTARY EMITTER FOLLOWER

Fig. 4

B-IIB1-0002x  
12-31-63 JG

Q23 and Q33 form a NPN-PNP complementary emitter follower circuit. This special configuration overcomes a common limitation of conventional emitter followers by providing equally fast response for both positive and negative going portions of a signal. The amplifier triggering signal from Q14 collector is applied to the base of Q23 and in slightly attenuated form is applied to the base of Q33. C21 compensates the voltage divider, R21, R22. The base potential of Q33, provided by the attenuator R21 and R22, assures compatibility with other trigger inputs by enabling us to set the emitter of Q33 at 0 volts. DC zero volts at Q33 emitter is assured by the INT TRIG DC LEVEL adjustment. R23 establishes the correct current for Q33. C23 is the bypass filter for Q33 collector.

Quiescent levels, Q23 and Q33:

- a. Q23 Base, 7.8v.
- b. Q23 Collector, 14v.
- c. Q23 emitter, 7.1v.
- d. Q33 Base, -.75v.
- e. Q33 Collector, -11v.
- f. Q33 Emitter, 0v.

C. SOURCE AND COUPLING SWITCHES (Figure 5)

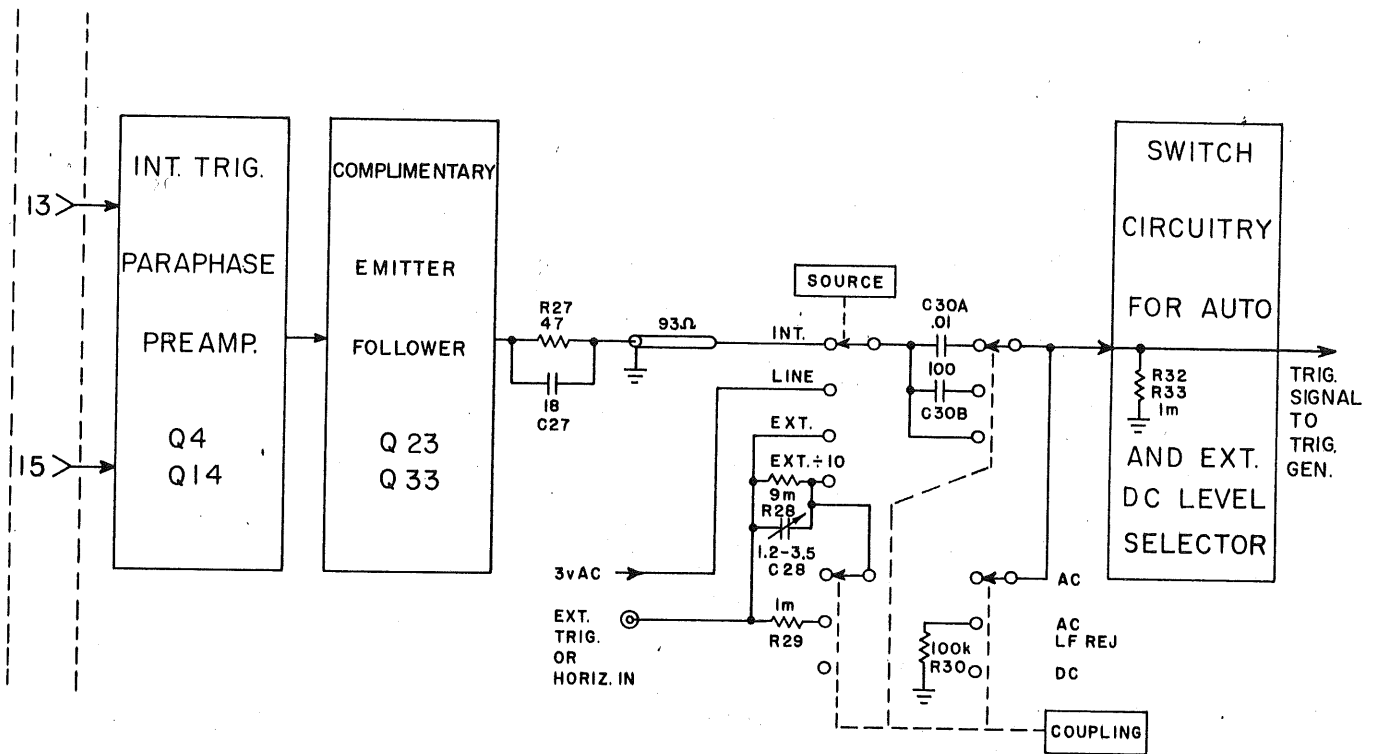

TYPE IIB1 INTERNAL TRIGGER PREAMPLIFIER  
SOURCE AND COUPLING SWITCH

Fig. 5

B-IIB1-0003x  
1-3-'64 jg

The SOURCE control (a lever wafer switch) allows for a selection of triggering signals -- INT, LINE, EXT and EXT  $\div 10$ .

The 6.3v AC signal is tied to pin 30 of the blue ribbon connector. The 6.3v is attenuated to 3 volts by R415 and R416 (located on the interconnecting plug schematic). This attenuation is necessary to enable the TRIG LEVEL control to have sufficient range to trigger on any portion of the sine wave. C416 helps to reduce the aberrations found on the sine wave at the power transformer secondary.

An external triggering signal may be applied to the EXT TRIG or HORIZ IN connector. In the EXT position, the input impedance is 1 meg and approximately 25 pf in all positions of the COUPLING switch except AC LF REJ, where the impedance drops to 100k. The EXT  $\div 10$  position uses the 9 meg (R28) and the 1 meg (R32 and R33) for  $\div 10$  attenuation in the AC and DC positions of the COUPLING switch. The input impedance is 10 meg at approximately 5 pf and can accept approximately 400 volts of triggering signal without damage. C28 compensates the voltage divider for the high frequency signals. Note that in the AC LF REJ position of the COUPLING switch, R29 is inserted in parallel with R28, dropping the input impedance to 1 meg but keeping the attenuation still at 10.

The COUPLING control (a lever wafer switch) selects the type of coupling required -- DC, AC or AC LF REJ. In the AC position, C30A and R32-R33 provide a coupling time constant which assures rejection of DC and very low frequency AC signals. AC coupled signals are 3 db down at 16 cps (TC = .01 sec). In the AC LF REJ position of the COUPLING switch, the coupling time constant is decreased so the AC rejection includes higher frequencies. AC LF REJ coupled signals are 3 db down at 16 kc (TC = 10  $\mu$ sec). This rejection is primarily intended to prevent triggering on the DC switching information encountered in alternate trace operation of a vertical plug-in unit.

D. SWITCH CIRCUITRY FOR AUTO AND EXT DC LEVEL SELECTION

See Figure 6.

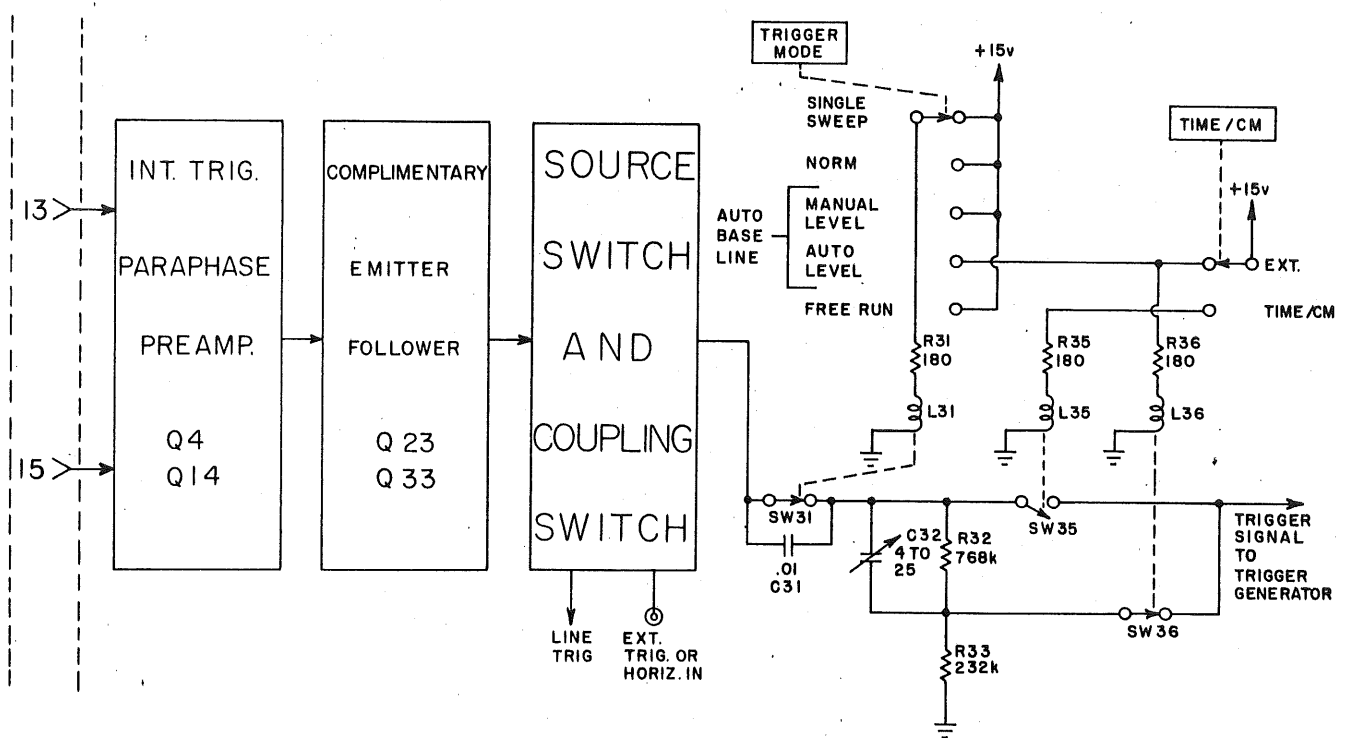

TYPE IIBI INTERNAL TRIGGER PREAMPLIFIER  
AUTO SELECTION

Fig. 6

B-11BI-0004 x

1-4-'64 jg

Normally, SW31 will be closed by the 15 volts being applied to R31 activating L31. When the TRIGGER MODE switch is in the AUTO BASE LINE -- AUTO LEVEL position, SW31 could either be open or closed, depending on the TIME/CM switch. With the TIME/CM switch in the time/cm position, SW31 will be open and the triggering signal is AC coupled through C31. For automatic selection of the triggering level, the triggering signal must be AC coupled. When the TIME/CM switch is in the EXT position, there is a possibility that it might be necessary to DC couple the signal, therefore, SW31 is closed and the EXT signal will be "DC" coupled. The COUPLING switch will still have to be set to the type of coupling desired.

L35 (SW35) and L36 (SW36) controls the path for the triggering signal. When the TIME/CM switch is in the TIME/CM position, L35 is activated closing SW35 (L36 is not activated and SW36 is open). The triggering is coupled directly to the TRIGGER GENERATOR circuit. The voltage divider, R32 and R33, was added to attenuate the EXT signal when the TIME/CM switch was in the EXT position (SW36 closed, SW35 open). This attenuation was required to provide for correct horizontal deflection sensitivity.

## II. TRIGGER GENERATOR

The trigger generator provides a trigger of uniform shape and polarity for the sweep generator. The input triggering signal from the INTERNAL PREAMP is fed to the cathode follower. Diode logic in the cathode of the cathode follower (selected by the TIME/CM switch) determines whether the signal is fed to the comparator or to the horizontal preamplifier. The output of the comparator can be selected from either side by the trigger polarity switch. This drives a tunnel diode trigger circuit which sends a signal to the sweep gating circuit.

Figure 7 is the block diagram of the TRIGGER GENERATOR.

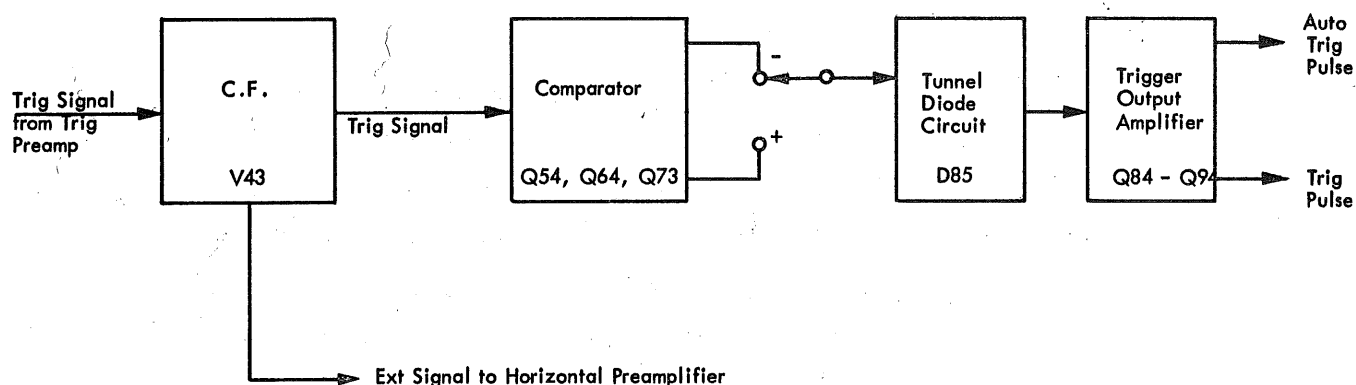

11B1 TRIGGER GENERATOR

Figure 7





The TIME/CM switch controls the diode logic in the cathode circuit of V43. Each diode logic circuit draws approximately 6 ma. When the TIME/CM switch is set to the TIME/CM position, D43 anode is tied to +100 volts through R44 (4.7k) and R49 (10k) forward biasing D43, allowing the triggering signal to be applied to the comparator circuit Q54 and Q64.

D46 anode is connected through D47, R47 and R48 to -15 volts. This cuts off D46 and the signal path to the HORIZ PREAMP is open.

When the TIME/CM switch is set to the EXT position, D46 is tied to +100 volts through D47, R47 and R49 (4.7k and 10k). This provides forward bias for D46, allowing it to conduct. The EXT HORIZ signal can now pass to the HORIZ PREAMPLIFIER. The DC level is raised from 1.7 volts on V43 cathode to approximately 7 volts by D47, a 5.1 volt zener. The 7 volts at the HORIZ PREAMP input places the CRT beam in the center of the screen in the EXT INPUT mode. D43 is cut off in this position by the -15 volts through R45 and R44. The signal path to the comparator circuit is open preventing a triggering signal from being generated.

B. COMPARATOR (Figure 9)

See Figure 9.

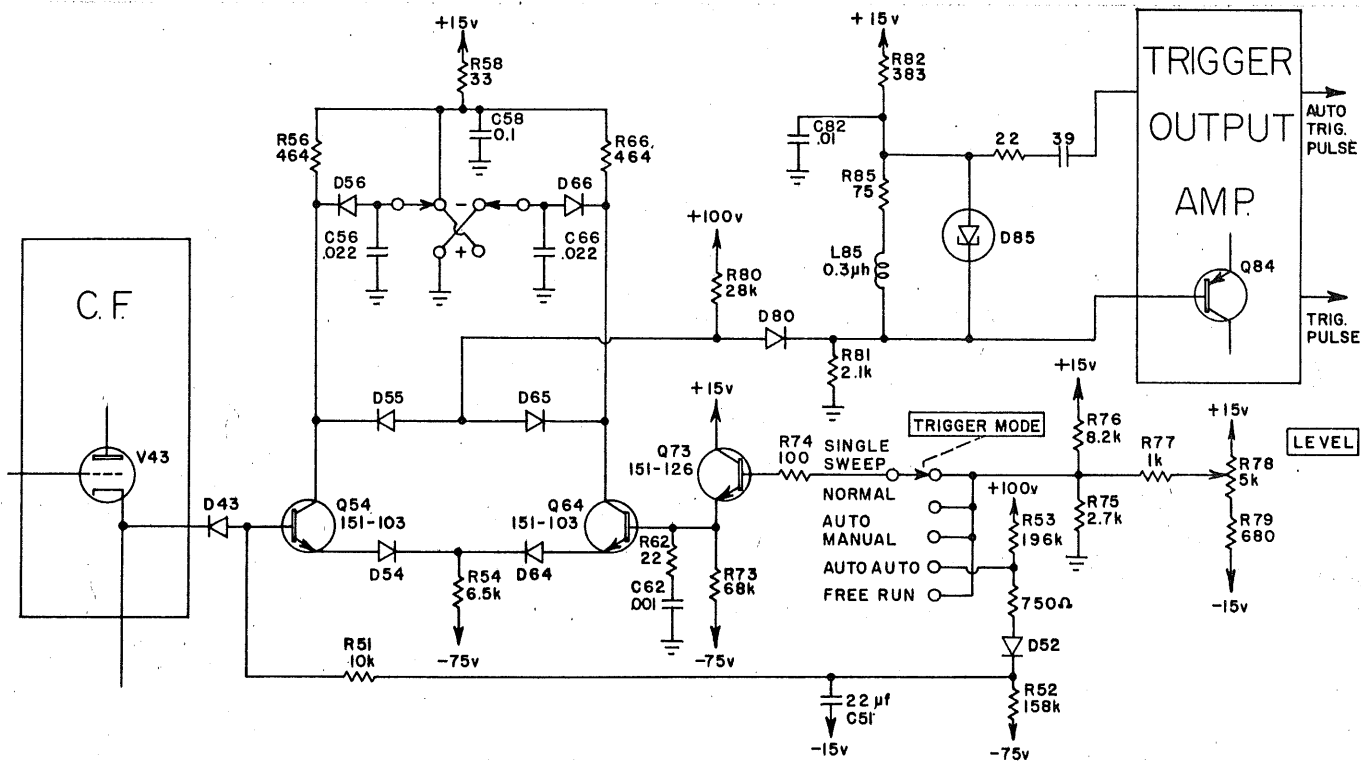

TYPE IIBI TRIGGER GENERATOR  
COMPARATOR CIRCUIT

Fig. 9

Q54 and Q64 form a sensitive current switch which provides a current trigger for the TD, D85. The trigger waveform on Q54 base is compared with the TRIG LEVEL voltage on Q64 base. When the TRIGGER MODE switch is in the AUTO-AUTO position, the voltage at the base of Q73 (or Q64 base) is a fixed voltage determined by the voltage divider, R53 and R52. The voltage at the base of Q73 and the base of Q64 will be slightly positive with respect to the base voltage of Q54. If the instantaneous signal voltage at the base of Q54 is more positive than the voltage at the base of Q64, Q54 will conduct. Therefore, as the positive-going portion of the triggering signal drives the base of Q54 from negative to positive, with respect to the base of Q64, the current through R54 changes from Q64 to Q54. Quiescently, D85 is in its low state with about 3.5 ma of current flowing through it. D85 requires about 4.7 ma to flip it to its high state. D80 is also forward biased in the quiescent condition with about 2.9 ma of forward current. Approximately 6.5 ma through R81 sets the voltage at the base of Q94 at 13.5 volts. The object of the trigger pulse from the comparator circuit is to cut off or back bias D80. The current that was flowing through D80 will then flow through the tunnel diode, D85, flipping it to its high state.

When the SLOPE switch is set to +, D66 is placed in parallel with R66 prohibiting the collector voltage of Q64 from moving when an input trigger pulse is present. D56 anode is grounded and the collector of Q54 will be free to move. Approximately 11 ma flows through R54 and as the positive going portion of a triggering signal drives the base of Q54 from negative to positive, with respect to the base of Q64, the current changes from Q64 to Q54, lowering the collector voltage of Q54 to approximately 9.5 volts. This will forward bias D55 and cut off D80, thus flipping the TD, D85, to its high state, initiating a triggering pulse for the sweep generator. As is characteristic of a tunnel diode, the transition from the low-voltage state to the high-voltage state occurs very rapidly, regardless of how slowly the current increases through the diode. Therefore, the TD, switching to its high state, provides the base of Q84 with a fast rise, negative going pulse.

When the SLOPE switch is set to -, D56 is placed in parallel with R56 preventing the collector of Q54 from moving and D66 anode is grounded allowing the collector of Q64 to move. Therefore, it is the collector voltage of Q64 which controls the flipping of the TD. With the SLOPE switch set to +, the tunnel diode will switch to its high state when Q54 comes into conduction, and with the SLOPE switch set to -, the tunnel diode will switch to its high state when Q64 comes into conduction.

The TRIG LEVEL controls the voltage at the base of Q64 through emitter follower Q73 in all positions of the TRIGGER MODE switch except the AUTO-AUTO position. The TRIG LEVEL control has a swing of about 26 volts and is limited by R76 and R75 to about 12 volts on the base of Q73. Q73 is long-tailed to -75 volts and provides a low impedance source for the base of Q64. R62 and C62 help to prevent oscillation. Although the comparator bases (Q54 and Q64) normally operate close together, it is possible for the bases to be about 22 volts apart. Q54 base can swing  $\pm 15$  volts and Q64 base can swing  $\pm 6$  volts. For this reason, D54 and D64 protect Q54 and Q64 from emitter to base breakdown.  $V_{EBO}$  for a 151-103 is 5 volts.

When the TRIGGER MODE switch is in the AUTO-AUTO position, the base of Q73 is connected to the voltage divider R53 and R52. The fixed voltage at the base of Q73 will be approximately 3.5 volts, just slightly positive with respect to the base of Q54. With the voltages of the bases of Q54 and Q64 only a few hundred millivolts apart, small triggering signals can change the state of the comparator circuit. R51 was added in case the triggering signal was riding on a DC level (for example, 5 volts). With R51 in the circuit, both Q54 and Q64 bases will be setting at the DC level and the small triggering signal can change the state of the comparator circuit.

C51 filters any AC signals that might be coupled to the base of Q73.

### C. TUNNEL DIODE CIRCUITRY

See Figure 10.

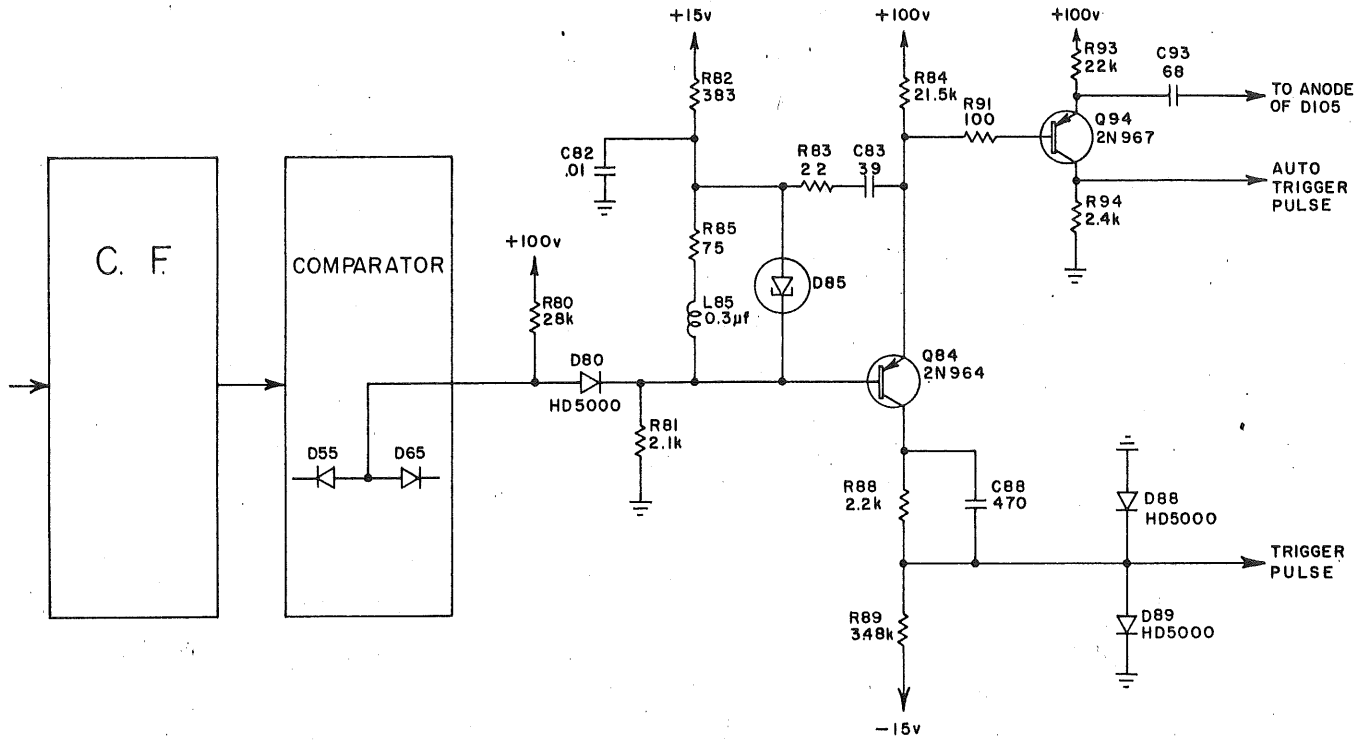

TYPE IIBI TRIGGER GENERATOR  
TUNNEL DIODE CIRCUITRY Fig. 10

B-IIBI-0007\*  
1-7-'64 jg

D85 is a 4.7 ma tunnel diode. When the tunnel diode switches from its low state to its high state, the cathode of D85 moves in the negative direction by about 500 mv. Risettime of this signal is approximately 1 nsec. During the time the TD switches, L85 looks like an open circuit and, therefore, the current that was passing through L85 is diverted to the TD assuring a fast switching time.

R85 is the load resistor for the tunnel diode which places it in the bistable configuration.

When the tunnel diode suddenly drives Q84 base negative, Q84 is driven further into conduction. C83 prevents the fast rise TD signal from appearing on the emitter of Q84 for about 6 nsec. This allows the signal to appear on the collector of Q84. The leading edge of the TD waveform appearing at the collector is used as the triggering signal for the sweep ( $T_r \approx 1.5$  nsec). After about 6 nsec, the larger portion of the base signal will appear on the emitter and very little signal on the collector. R83 tends to degrade the risetime of the collector signal to prevent ringing. D88 and D89 limit the pulse amplitude to prevent crosstalk to the Sweep Generator.

Q94 is a germanium transistor and it is used in the circuit as a phase inverting amplifier. The operation of Q94 circuit is similar to Q84 circuit where only the leading edge of the triggering pulse appears on the collector of Q94. This positive signal of approximately 50 mv goes to D105 cathode in the AUTO circuit through C102 and D102.

A negative signal of approximately 500 mv appears at the emitter of Q94. C93 is a bypass capacitor that grounds into the AUTO circuit, instead of chassis ground to prevent group loops.

### III. SWEEP GENERATOR

The sweep generator produces four simultaneous output signals:

1. A 10 volt positive-going sawtooth that is applied to the TIME/CM switch for moving the CRT beam horizontally. The sweep waveform is also available for external use at the SWEEP OUT front panel connector.
2. A 6.5 volt negative-going CRT unblanking pulse having the same duration as the sweep sawtooth rise which is converted to a current driving source at pin 2 of the interconnecting socket. This unblanking signal is coupled to the oscilloscope CRT circuit when the TIME/CM switch is set to any of the sweep positions.
3. A 15 volt positive-going pulse (+ GATE OUT) having the same duration as the sweep sawtooth rise. This signal is coupled to a front panel connector for external use.
4. A 4 volt minimum negative-going multi-trace sync pulse occurring at the end of the sweep sawtooth rise. This signal is coupled to the vertical plug-in unit interconnecting socket causing a multi-trace unit, operating in the alternate mode, to switch channels.

In most applications, each cycle of events is started by a trigger pulse from the Trigger Generator. However, it is also possible to free run the Sweep Generator; that is, the end of one cycle will cause the next cycle to begin. The desired operation is selected by setting the TRIGGER MODE switch.

The TRIGGER MODE switch provides four ways to switch the Sweep Gating Multi TD (D135) so that the sweep will begin.

1. In SINGLE SWEEP, two pulses are required to start each sweep. First, a pulse from the reset amplifier, originating at the RESET push-button or from an external signal through pin F of J101 in the 647. After reset, the TD may be switched by a pulse from the Trigger Generator.
2. In the NORMAL operation, the TD is switched by a pulse from the Trigger Generator.

3. FREE RUN results in recurrent sweeps that are supposed to be independent of any triggering signal. By careful adjustment of the TRIG LEVEL control, stable triggering may be obtained. The retrace portion of one sawtooth switches the TD to begin the next sawtooth.
4. AUTO (Manual and Auto level) is a combination of NORMAL and FREE RUN. If there are no trigger pulses supplied by the Trigger Generator, the AUTO circuit will "hold" the sweep gating multi TD in the "free run" condition. When the pulse comes from the Trigger Generator, the AUTO circuit robs current from the TD thus switching it to the NORMAL (triggered) condition. Only if the trigger pulses continue to arrive every 80 msec or less, the AUTO circuit will remain in the "normal" condition and each sweep will be triggered sweep. Whenever the period between trigger pulses exceeds 80 msec, an RC network resets the AUTO circuit restoring the extra current to the TD and it resumes free running.

Figure 11 is a simplified block diagram of the Sweep Generator.

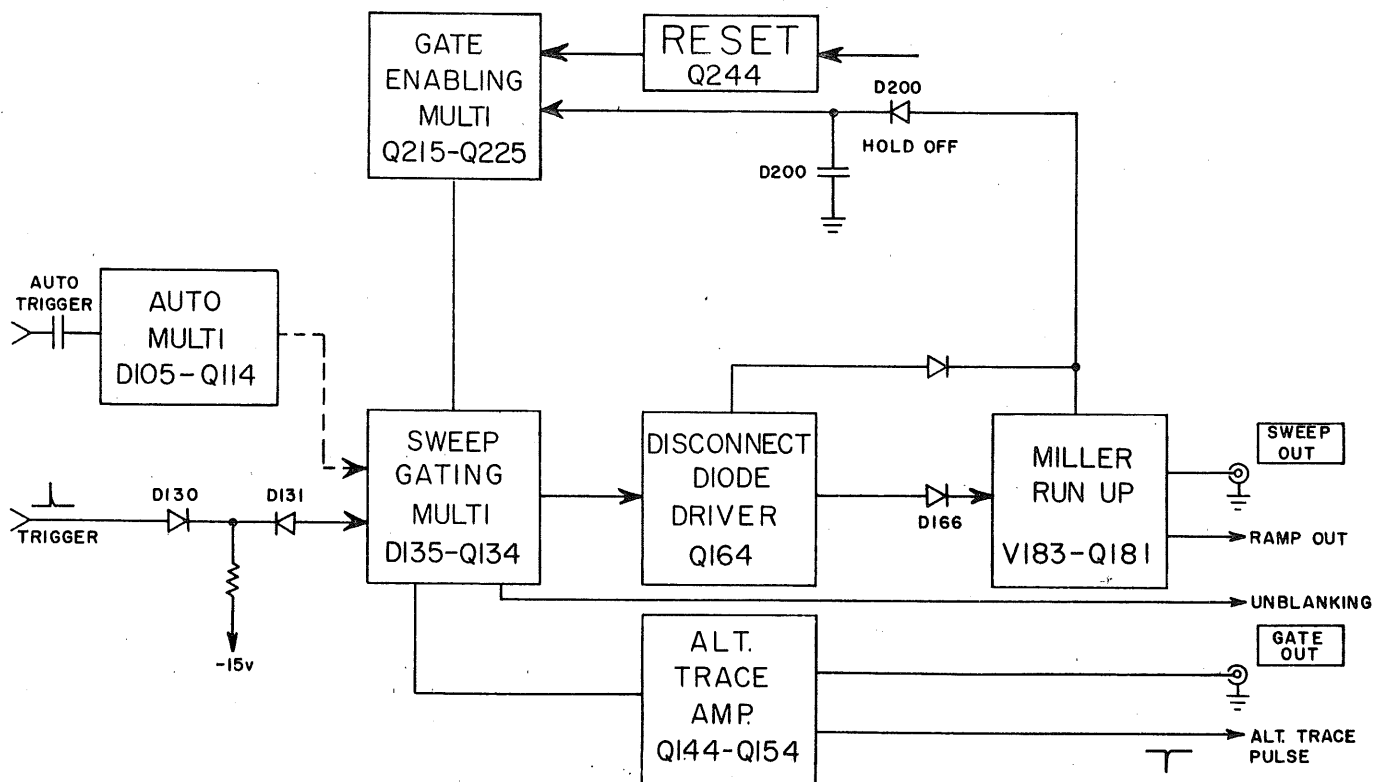

TYPE IIB1 SWEEP GENERATOR  
BLOCK DIAGRAM

Fig. 11



Following is a brief sequence of operation of the Sweep Generator.

A positive going trigger pulse flips the Sweep Gating TD (D135) into its high state. The output from the Sweep Gating circuit (Q134 collector) is a negative going step. This negative step appears amplified at the Disconnect Diode Driver output (Q164 collector). The negative step at the collector of Q164 cuts off the Disconnect Diode (D166). With the disconnect diode cut off, the Miller Run-Up circuit (V183-Q181) may produce a positive going sawtooth waveform, 10 volts in amplitude. The sweep ramp is fed through the hold-off diode (D200) to the Gate Enabling multi. As the end of the sweep is reached, the Gate Enabling multi flips, opening the Sweep Gating TD current path. Reverse current through the TD (D135) flips it to the locked-out (non-triggerable) low state. The resultant positive step at the output of the Sweep Gating Multi circuit (collector Q134) brings the disconnect diode into conduction. The sweep ramp is terminated and retrace begins. The hold-off diode opens allowing the hold-off cap (C200) to discharge slowly. At the end of hold-off, the Gate Enabling Multi flips to its quiescent state and the TD circuit is returned to its triggerable state.

The next portion will describe the Sweep Generator in detail with the TRIGGER MODE switch in the NORMAL position.

### A. Sweep Gating Multi

Figure 12 is the simplified diagram of the sweep gating multi.

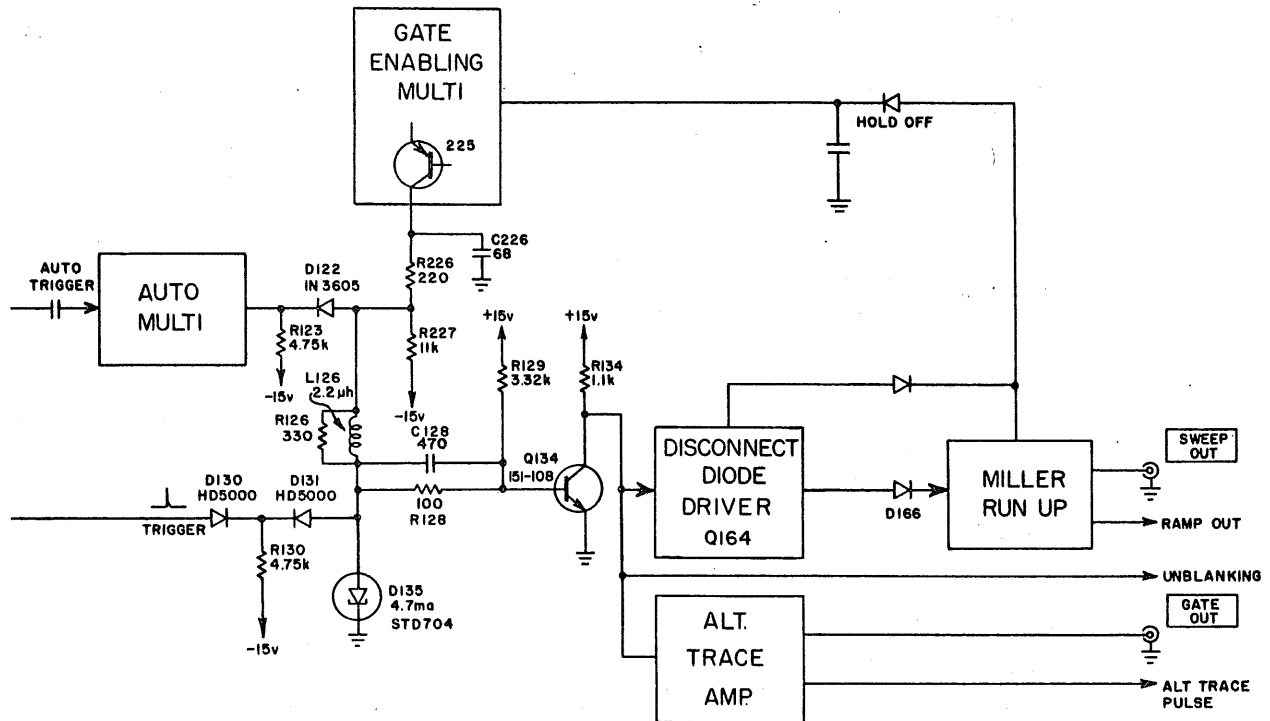

TYPE IIB1 SWEEP GENERATOR  
SWEEP GATING MULTI

Fig. 12

B-IIB1-0009x  
1-8-'64 jg

In the quiescent state, that is, when the sweep generator is triggerable but no sweep is being generated, the Gate Enabling Multi, Q215 and Q225, is in the following condition: Q215 is cut off and Q225 is conducting, setting the collector voltage at about 1.4 volts and drawing about 6 ma. Figure 13 is the current distribution for the Sweep Gating multi in its quiescent state.

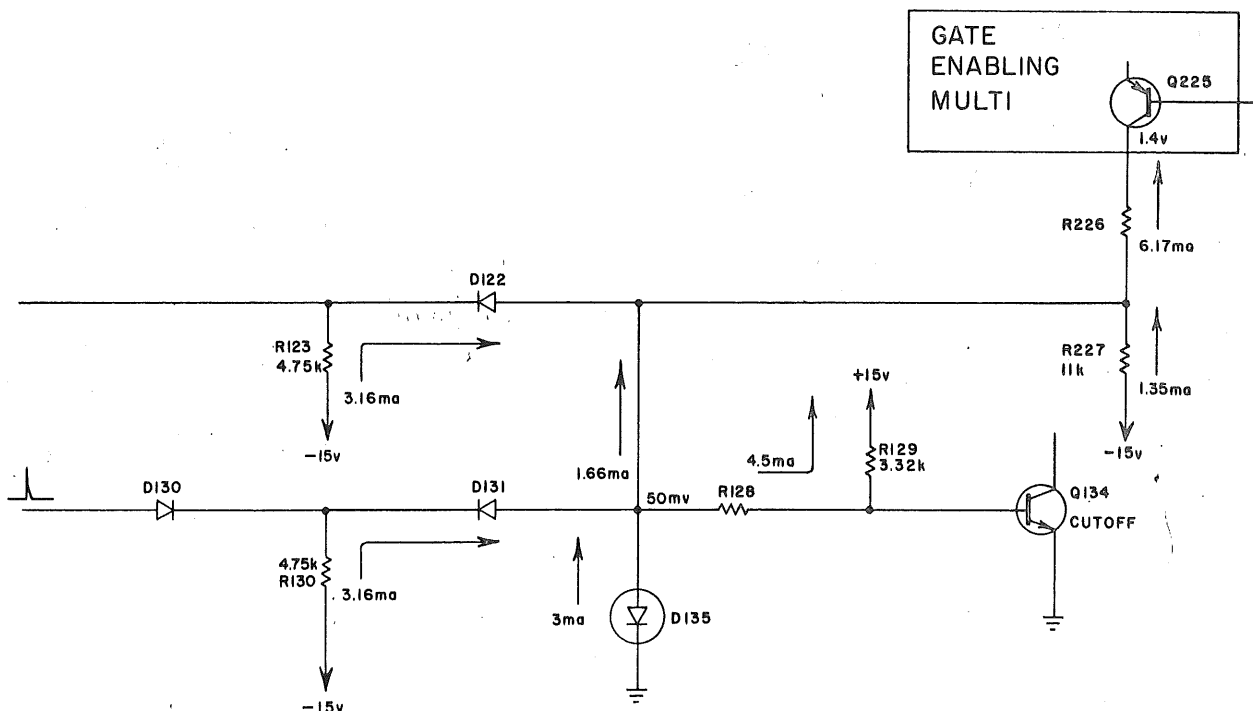

TYPE IIBI SWEEP GENERATOR  
CURRENT DISTRIBUTION

Fig. 13

B-IIBI-0010.1  
1-10-64 jg

D135 is a 4.7 ma tunnel diode. In the quiescent condition, it is in the low state with about 3 ma of forward current. D130 is cut off and D131 is conducting 3.16 ma. Conducting D122 supplies the required amount of current for Q225. It is well to note at this point that since D135 is a 4.7 ma TD and 3 ma of current is flowing, only 1.7 ma is required to flip it from its low state to its high state. The anode of D135 is at approximately 50 mv and Q134 base at  $\approx 400$  mv. Q134 is just cut off because 400 mv is not sufficient to turn it on. About .6 volts is required to turn on Q134. The Collector of Q134 is setting at approximately +6.5 volts. This voltage is produced by the conduction of Q164 through R136 and R134. Q164 is turned on harder, forward biasing the disconnect diode, D166, preventing the generation of a sawtooth.

Following is the sequence of operation at the start of the sweep.

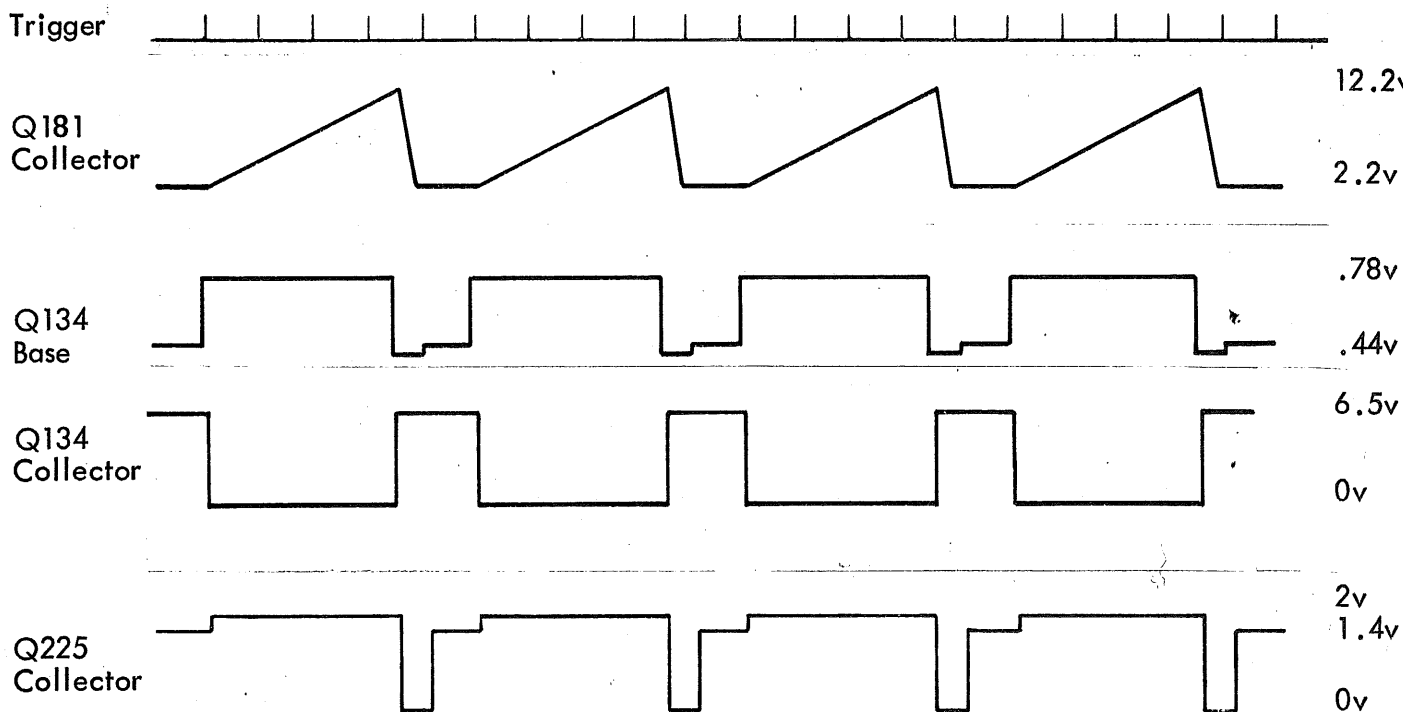

A positive going trigger pulse (6 nsec wide) lifts D130 into conduction, disconnecting D131. The current through Q225 does not decrease, therefore, D131 current is diverted to the TD. The 3.16 ma added to the 3 ma of quiescent TD current is sufficient to flip the TD to its high state.

As the TD flips, its anode lifts to about 500 mv, raising the base of Q134 to approximately 780 mv. After the trigger has passed (6 nsec), D131 conducts again robbing the TD of the 3.16 ma but the TD hysteresis will not allow the TD to flip to its low state, however, until its current is reduced to about .4 ma. With the base of Q134 at approximately 780 mv, Q134 is turned on dropping its collector voltage from +6.5 volts to near 0 volts. This negative pulse (through the disconnect diode driver Q164) reverse biases the disconnect diode (D166) and the Miller run-up is allowed to generate a sawtooth.

As the sweep ramp reaches its maximum amplitude, the Gate Enabling Multi flips, Q215 turns on and Q225 turns off, dropping the top of R226 to 0 volts. The tunnel diode will revert to its low (non-triggered) state when Q225 turns off. As D135 flips to its low state, Q134 cuts off and its collector rises to approximately +6.5 volts. This positive step increases Q164 conduction, forward biasing the disconnect diode, D166, and ending the sweep. Figure 14 is the current distribution for the Sweep Gating Multi during the hold-off period.

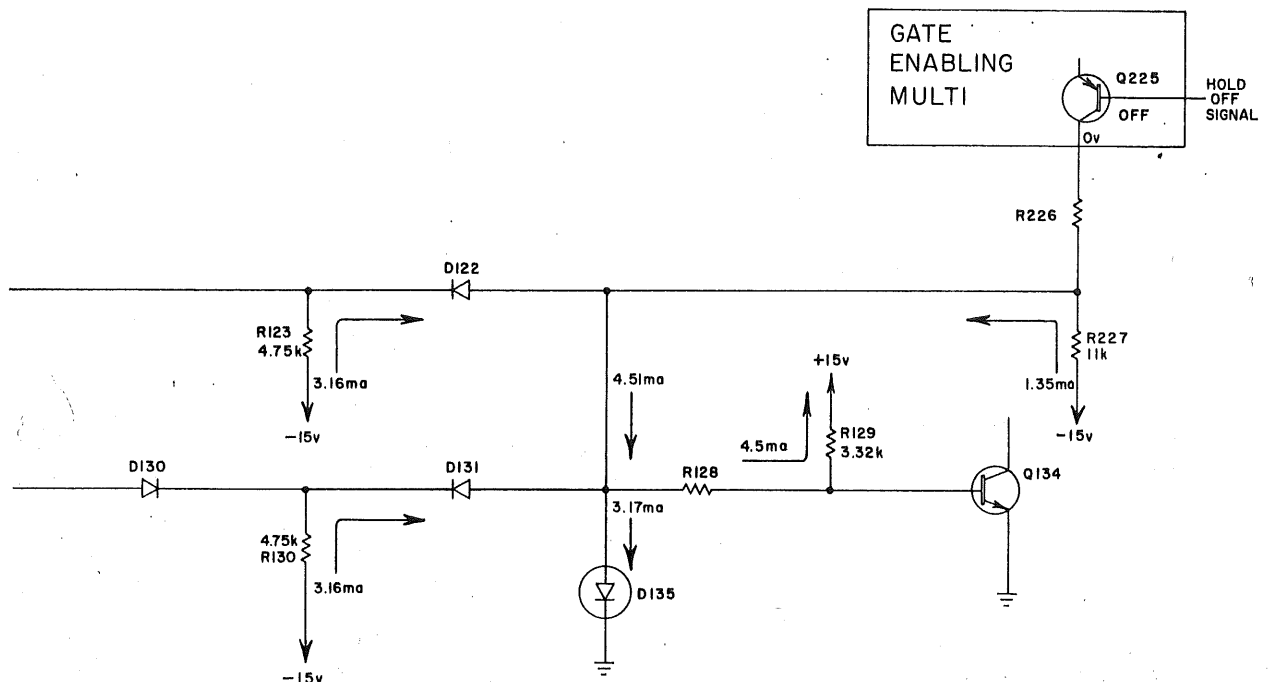

TYPE IIBI SWEEP GENERATOR  
CURRENT DISTRIBUTION

Fig. 14

B-IIBI-0010.2  
1-10-64 jg

During the hold-off period, D135 has 3.17 ma of reverse current preventing any triggering signals from flipping the TD to its high state. At the end of the hold-off period, the Gate Enabling Multi will flip turning Q215 off and turning Q225 on, setting the TD into its triggerable state. The Sweep Gating output waveform (Q134 collector) is a negative going (6.5 to 0v) rectangular waveform of the same duration as the sweep. This negative pulse

has three functions:

1. It drives the diode driver amplifier for turning on and off the sweep.
2. Serves as the unblanking pulse for the CRT circuit.
3. Drives the Alternate Trace Amplifier (+ GATE and ALT TRIG pulse).

B. Disconnect Diode Driver (Q164)

Figure 15 is the simplified diagram of the disconnect diode driver.

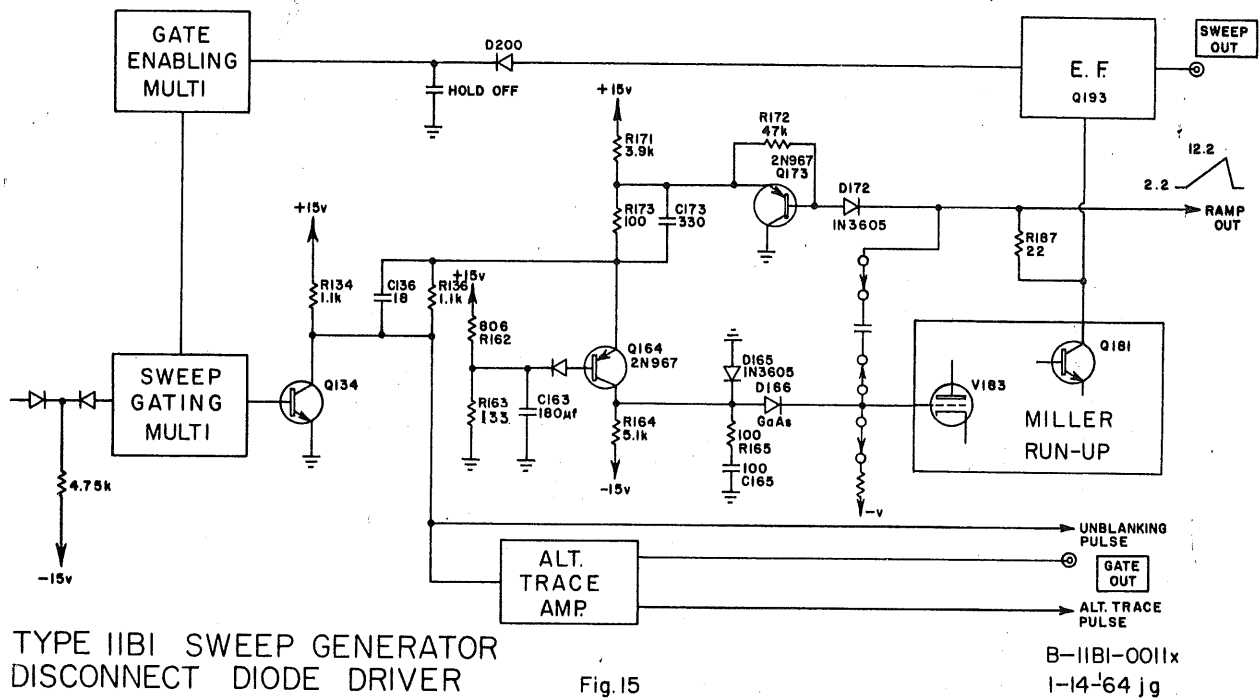

The disconnect diode driver, Q164, provides the negative going step on its collector which turns off the disconnect diode, D166, initiating the sweep. Quiescently (before sweep), Q164 is conducting. The base voltage is setting at approximately 3.4 volts, determined by the divider R162 and R163. C163 keeps the base set to AC ground. The emitter potential is set at approximately 3.8 volts and the collector voltage is setting at approximately +1 volt. D166 is forward bias and clamps the grid of V183 near zero volts.

The following is the sequence of operation at the start of the sweep.

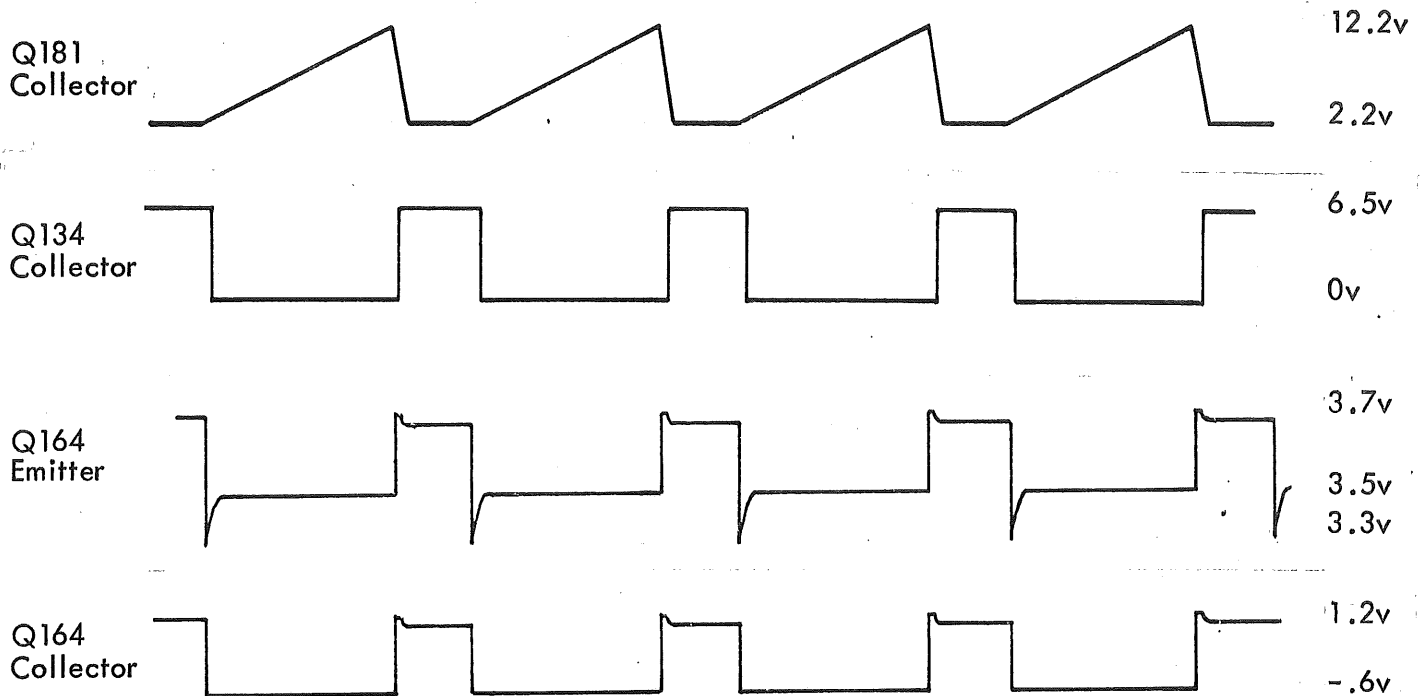

When an incoming trigger signal flips the Sweep Gating TD, D135, the negative step at the collector of Q134 passes through C136 to the emitter of Q164. The emitter of Q164 drops from 3.8 volts to approximately 3.3 volts and then returns on a rather fast RC curve to 3.5 volts. The collector of Q164 drops from approximately +1 volt to -.6 volts and is clamped there by D165. D165 protects D166 from reverse bias breakdown. This negative step at the collector of Q164 pulls down on D166 anode, cutting it off. The sweep is now allowed to start. RC network, R165-C165, keeps the sweep from oscillating while in the quiescent condition. The RC network also helps to prevent the negative step at Q164 collector from becoming capacitively coupled across D166.

At the end of the sweep, the positive step from the collector of Q134 lifts the emitter of Q164, which provides a positive step at the collector of Q164. This forward biases D166, ending the sweep and retrace starts.

Q173 is used for obtaining a fast, linear retrace for the sweep sawtooth. This feedback circuit is required to give extra driving signal for Q181 base during retrace. When the sawtooth signal goes positive, this is decreasing conduction in Q181 (turning it off) and at the peak of the signal, Q181 is almost turned off. Therefore, to turn Q181 on hard during the retrace, the positive feedback circuit of Q173 was added.

Quiescently, before sweep start, Q173 is on, D172 (isolation diode) is on and the sweep start voltage is held constant by the collector signal on Q164 effecting the grid of V183. When the emitter of Q164 goes negative (initiated by the TD flipping), Q173 is turned off (negative signal on its emitter) and the collector signal of Q164 disconnects D166 starting the sweep. To prevent turning on of Q173 during the sweep run-up, R172 was added to clamp the base of Q173.

At the end of the sweep (start of retrace), the emitter of Q164 goes positive, turning on Q173 and also the collector signal of Q164 turns on D166, thus ending the sweep and retrace starts. The sawtooth waveform on the collector of Q181 starts down (negative going) and turns on D172. The base signal of Q173 is applied to the base of Q181 (through Q173, Q164 and V183) to provide a fast, linear retrace preventing oscillations and other side effects from occurring in the Miller circuit.

D163 was added to correct for changes occurring to the sweep start with temperature variations. As the temperature varied, the junction voltage of D172 and Q173 would change, effecting the emitter voltage of Q164 and the grid voltage of V183. A change in grid voltage would change the sweep start. The junction voltage of Q164 would compensate for this change but not sufficiently, therefore, D163 was added to keep the sweep start constant. It is felt that the two junction voltages of Q164-D163 would compensate for the junction voltage changes of Q173-D172.



The voltage divider, R162-R163, setting the base voltage of Q164, is tied directly to pin 22 of the interconnecting which is tied directly to the power supply. This arrangement helps to prevent jitter. A uniform sweep starting point assumes greater importance with only a 10v sweep ramp out of the Miller circuit.

### C. Miller Run-Up Circuit

Figure 16 is the simplified diagram of the Miller Run-Up circuit.

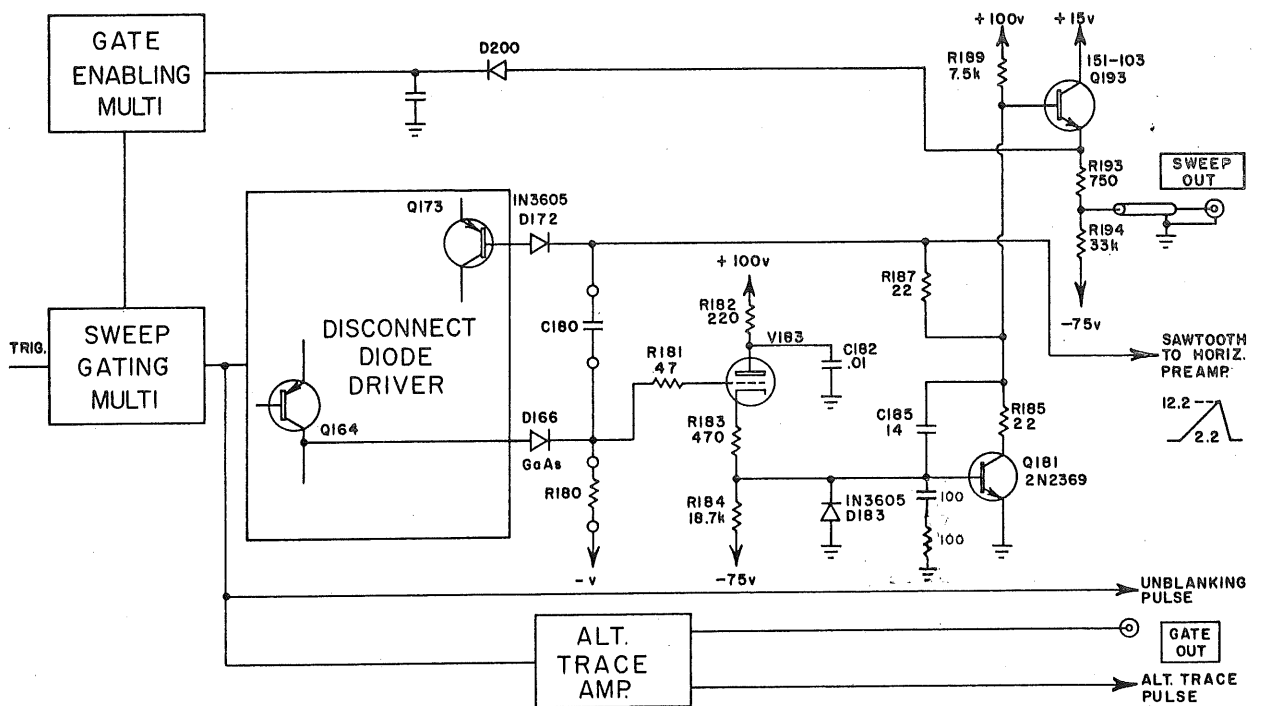

TYPE IIB1 SWEEP GENERATOR  
MILLER RUN-UP

Fig. 16

B-IIB1-0012x  
1-28-64 jg

V183 (input CF) and Q181 (high gain amplifier) form a Miller run-up circuit producing a 10 volt peak-to-peak linear sweep ramp. The voltage excursion at the collector of Q181 is from approximately +2.2 volts to 12.2 volts. Design specs for sweep linearity are 1%. Leakage currents in the timing circuits must not exceed 20 na from all sources at high ambient temperatures. The nuvistor input to the miller amplifier, a low leakage Tektronix GaAs disconnect diode and low leakage Tektronix made timing capacitors all help to keep leakage currents to a minimum.

Quiescent current paths establish the stable starting points for the sweep ramp. Current flows through the timing resistor, D166, and Q164 to +15 volts clamping the grid of V183 near zero volts, assuring a constant sweep start.

To initiate a sweep, D166 is cut off by the negative signal at the collector of Q164. The timing resistor current previously flowing through D166 is diverted to the timing capacitor. The timing capacitor will begin to charge. V183 grid and cathode begin to fall toward -75 volts. This change applied to Q181 base is inverted and greatly amplified by Q181. This amplified change is fed back to the top of the timing capacitor, opposing the change at V183 grid. The opposing signal will keep the grid of V183 from changing by more than 70 mv. This grid change will depend on the system gain. As the voltage drop across the timing resistor remains virtually constant, the current into the timing capacitor will be virtually constant. A constant current into a capacitor will result in a linear ramp across it.

When the sweep has reached the required amplitude (10 volts), D166 will turn on. Conduction was caused by the positive signal at the collector of Q164 produced by D135 (TD) flipping to its low state. The charging current into the timing capacitor is diverted through D166. The grid of V183 is clamped near zero volts. Timing capacitor discharge current flow is through D166, Q164, and the emitter resistors to +15 volts. At the start of the retrace, D172 will conduct applying a feedback signal, through Q173, back to the base of Q181 assuring a fast, linear retrace.

D 183 in the cathode circuit of V183 protects Q181 from reverse emitter to base breakdown damage during warm-up or if V183 should open.

Various resistor and RC networks (R187, R185, C185, R181, C186 and R186) in the Miller circuit prevent oscillations at some sweep speed.

D. Gate Enabling Multi

Figure 17 is the simplified schematic.

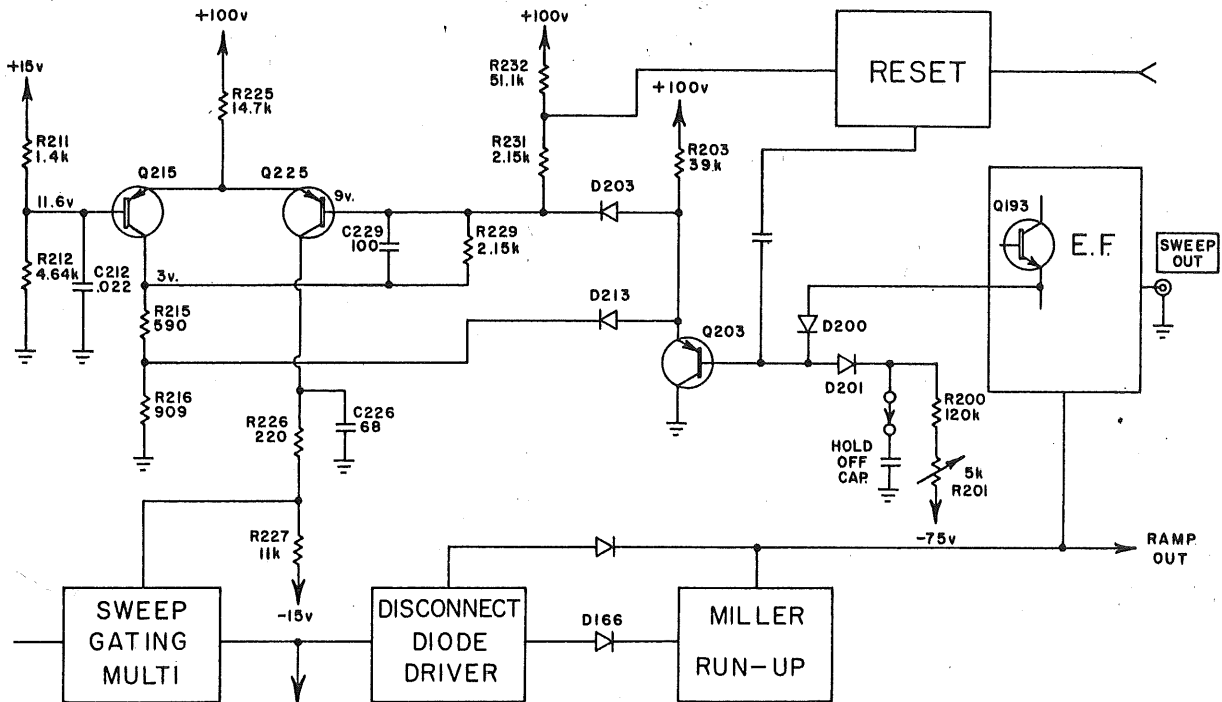

TYPE IIB1 SWEEP GENERATOR  
GATE ENABLING MULTI

Fig.17

B-IIB1-0013x  
1-31-64 jg

The Gate Enabling Multi (Q215 and Q225) is a bistable circuit. In the quiescent state, Q225 draws approximately 6.17 ma from the sweep gating TD and from R227. Q215 is cut off. As the sweep reaches its maximum amplitude, the Gate Enabling Multi will flip. Q225 will draw zero current from the TD circuit causing the TD to flip to its low state. At the end to the hold-off period, Q215 and Q225 will return to their quiescent state and enables the Sweep Gating TD to accept a trigger.

Let's assume that the Gate Enabling Multi is in its quiescent state with Q225 conducting and Q215 cut off. Sweep has started due to triggering signal flipping the sweep gating TD.

Following is the sequence of operation during the sweep.

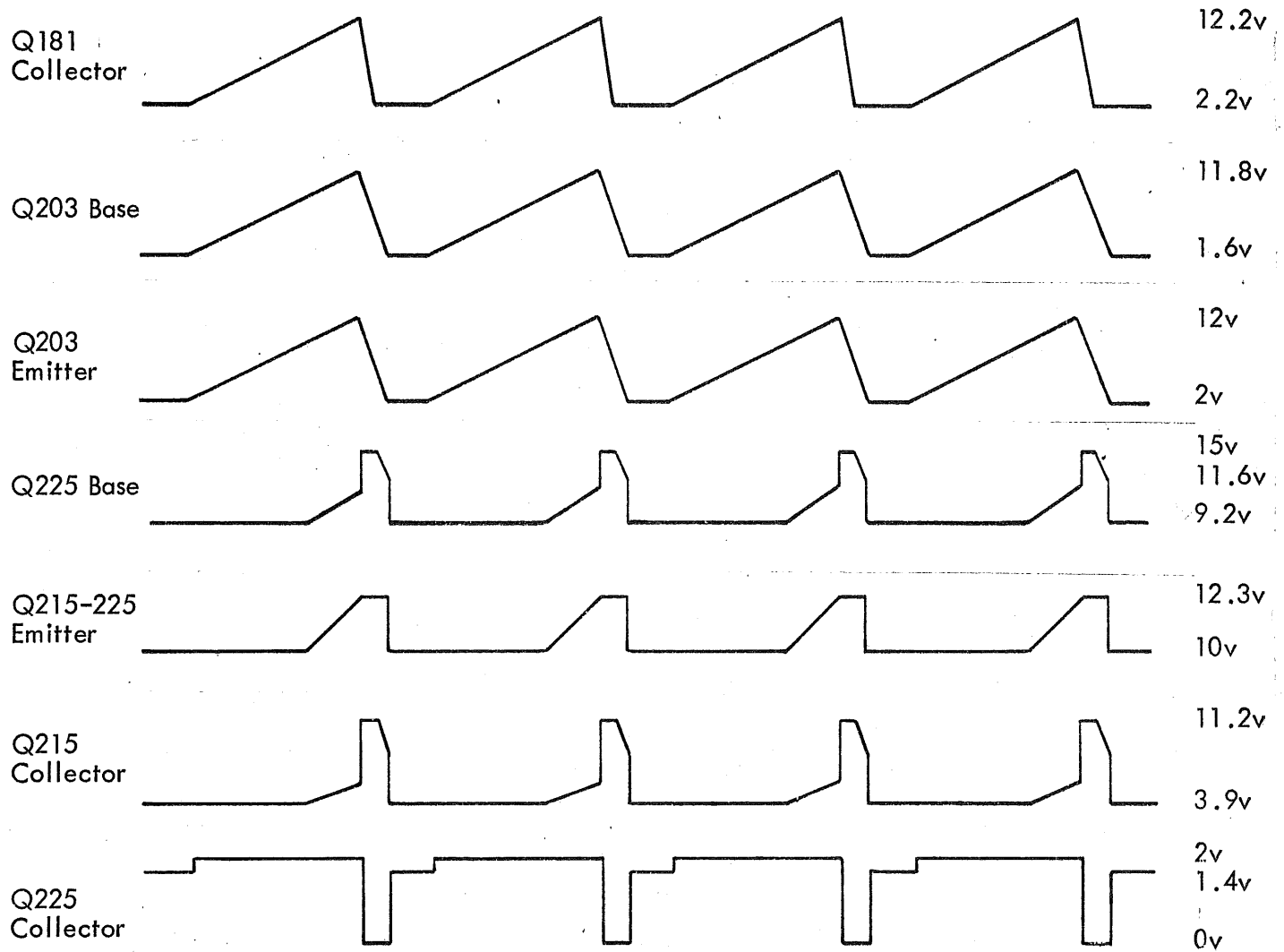

The sawtooth signal at the collector of Q181 is available to the Horizontal preamp through the TIME/CM switch and is also applied to the base of Q193. The rising voltage at the emitter of Q193 supplies the front panel output SWEEP signal and also charges the hold-off capacitors, C200, through diodes D200 and D201. The voltage divider, R193 and R194, establishes near zero volts for the sweep start at the SWEEP OUT connector.

The hold-off cap will charge to approximately 11.5 volts (the ramp maximum excursion). As the hold-off capacitor charges, the base and emitter of Q203 follows the positive excursion.

Quiescently, Q225 base is at approximately 9 volts. D203 comes into conduction as the sweep ramp reaches approximately +9.3 volts on the emitter of Q203. As the ramp continues to rise, Q225 base and emitter follows the ramp. The base of Q215 is setting at approximately +11.6 volts. As Q225 emitter (Q215 emitter) approaches this level, Q215 begins to conduct. Q215 collector pulls up (goes positive), lifting Q225 base (through C229) out of conduction. The emitter current flowing through Q225 is diverted to Q215 and the multi flips.

When Q215 goes into full conduction, its collector rises to approximately 11 volts allowing Q225 base to rise to approximately 14.5 volts, cutting off D203.

The Sweep Gating Multi TD current path through Q225 is open and the TD will flip to its low state, stopping the sweep and causing retrace to begin.

When the retrace starts, the charge on the hold-off capacitor holds D200 cathode while the falling retrace waveform on the anode cuts off the diode. During the sawtooth rise, the hold-off capacitor, C200, charged through D200, but must now discharge through the high resistance of R200 and R201. The timing capacitor will have discharged, restoring the Miller Run-Up circuit to the quiescent level, before Q203 base voltage reaches the quiescent level.

As the hold-off capacitor discharges, the emitter of Q203 falls. When the emitter reaches approximately 6.8 volts, D213 will start to conduct, effecting the collector voltage of Q215 and base voltage of Q225. As the hold-off signal continues down (negative), Q215 collector and Q225 base will follow.

When Q225 base reaches its emitter potential of approximately 11.4 volts, Q225 will start to conduct and the multi will flip to its quiescent state. With Q225 conducting, it draws current from the Sweep Gating TD circuit, returning it to its 3 ma triggerable state. The entire sweep generator is then restored to the quiescent condition. D201 (base of Q203) has a function only in the single sweep mode of operation.

The HF STABILITY control (R201) permits the operator to vary slightly the time between the completion of a sweep and the instant when the sweep generator again becomes triggerable. As Q225 turns on after a sawtooth retrace, a very short but sometimes significant amount of time is required for the current through the tunnel diode, D135, to reach the quiescent level. This recovery time is significant only at high frequency triggering signals (>10 mc) or when the relationship between the sweep rate and triggering frequency is such that the sweep gating trigger pulse tends to trigger each new sweep while the tunnel diode current is approaching the quiescent level.

A display obtained under these conditions may jitter horizontally. The operator can minimize and often eliminate the jitter by resetting the HF STABILITY control. Adjustment will either advance or delay the Q225 turn-on time so that D135 can stabilize at the quiescent level in an interval between sweep gating trigger pulses.

E. Single Sweep Mode

Figure 18 is the simplified diagram.

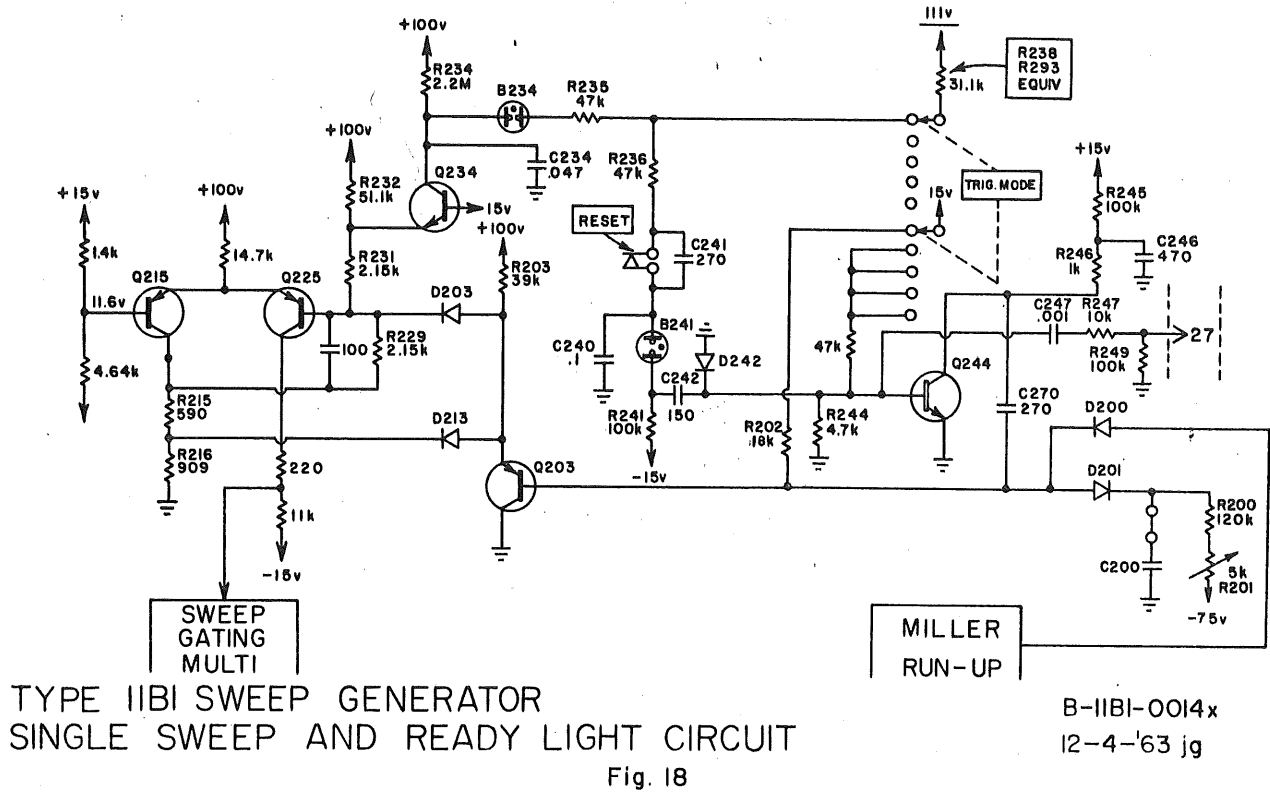

Fig. 18

In the SINGLE SWEEP mode of the TRIGGER MODE switch, the sweep must be set to the triggerable state before a sweep can be generated. The RESET button will light when the sweep is in the triggerable state. The next triggering signal will initiate the sweep. When the sweep is started, the RESET light will extinguish. At the end of one sweep the system returns to its single sweep quiescent condition.

As described previously in the NORMAL mode discussion, the retrace portion of the sawtooth normally allows the discharging hold-off capacitor, C200, to pull down the base of Q203 to near zero volts. D213 would have conducted, turning on Q225. However, in the SINGLE SWEEP mode, R202 is connected to +15 volts, forming a divider with R200 and R201. This divider stops the hold-off capacitor from discharging completely. The emitter of Q203 does not

drop sufficiently to cause D213 to conduct and Q225 does not turn on. D200 becomes reverse biased, but D201, in series with the divider, remains on. Since Q225 does not turn on following a sweep, the sweep generator becomes locked in an inoperative state. Note that the SINGLE SWEEP quiescent condition differs from the NORMAL quiescent condition in the following conditions: Q225 is drawing no current from the sweep gating TD circuit. The TD is in its reverse bias state. Triggers cannot flip the TD, D135, to its high state.

With Q215 conducting, Q234 is held off by the voltage divider R216, R215, R229, R231 and R232 setting the voltage at the emitter of Q234 at approximately 18 volts. The RESET lamp (housed in the RESET switch push-button), B234, is not lit, indicating the inoperative state of the generator.

The Sweep Generator can be reset to the operative (triggered) state either by pressing the RESET button or by applying a positive going pulse to pin F on J101 on the rear panel of the 647 oscilloscope. The external reset pulse amplitude must be greater than 5 volts and the risetime ( $T_r$ ) less than 5  $\mu$ sec. The above requirements are necessary in order that adequate energy may pass through C270.

In the SINGLE SWEEP mode, Q244 is normally off and C242 is charged to about -15 volts. When the RESET button is pressed, a voltage divider is formed consisting of R241, B241, R236 and R238-R293 in parallel. The top of R236 drops to approximately 90 volts raising the top of the B241 to approximately 76 volts, igniting the neon. This supplies a fast rise positive pulse at the junction of R241 and C242. This pulse is coupled through C242 and turns on Q244, driving it to saturation. The collector of Q244 drops from 15v to zero for the duration of the pulse. This negative going pulse is applied through C270 to the base of Q203. (At this time, D201 serves its only purpose. It is reverse biased by the negative reset pulse so that the hold-off capacitor will not pass the pulse to ground.) The pulse pulls down Q203 emitter which turns on D213. This action turns on Q225, flipping the multi. The base of Q225 drops to about 9 volts turning on Q234 and the reset lamp, B234, lights to indicate that the sweep generator is ready to be triggered. At the end of one conventionally triggered sweep, the sweep generator will again become inoperative. The circuit has returned to its SINGLE SWEEP quiescent condition.



F. Free Run Mode

Figure 19 is the current distribution in the TD circuit during the free-run mode of operation.

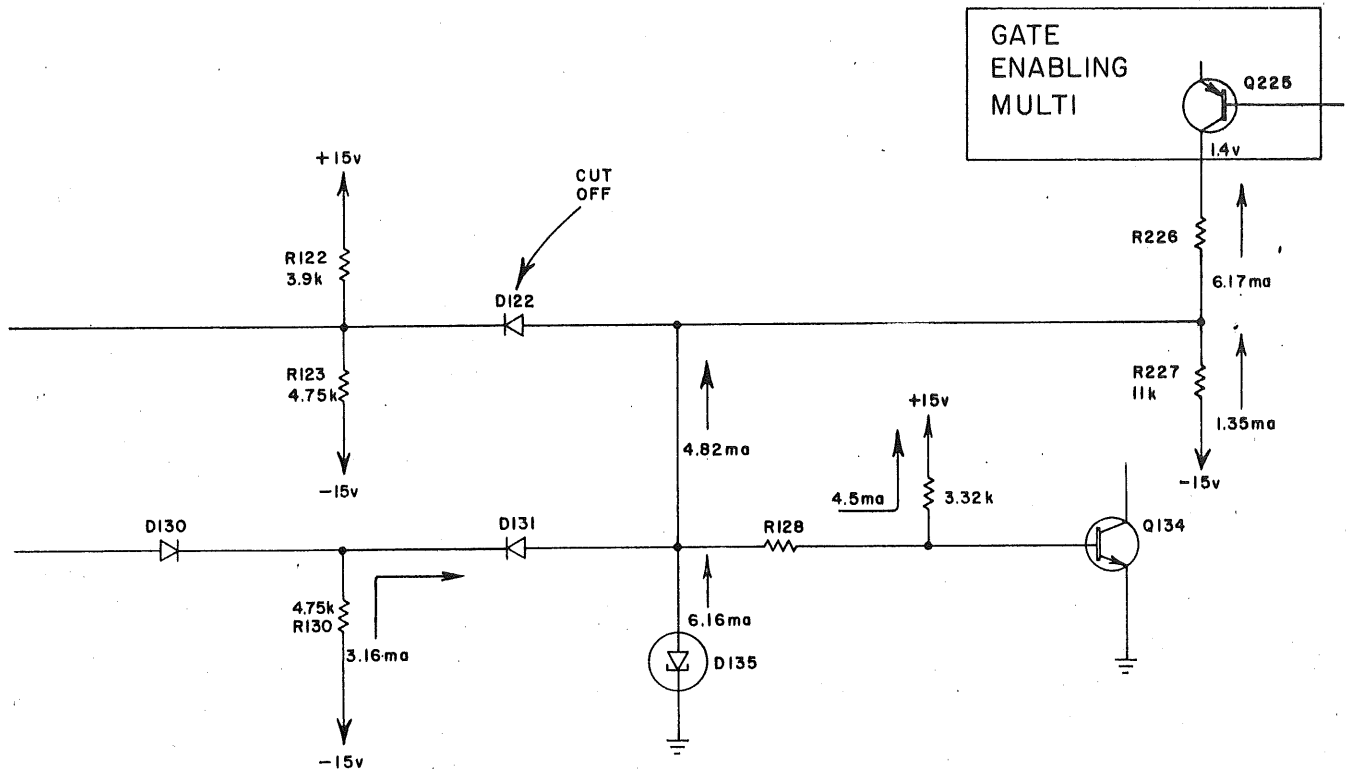

TYPE IIBI SWEEP GENERATOR  
CURRENT DISTRIBUTION - FREERUN

Fig. 19

B-IIBI-0015  
1-23-64 jg

In the Free Run mode of the TRIGGER MODE switch, the top of R122 is connected to +15 volts causing D122 to be cut off. The Q225 current that was carried by D122 in NORMAL operation is now carried by the tunnel diode, D135. When (at the end of hold-off) the Gate Enabling Multi draws 6.17 ma from the TD circuit, 6.16 ma must flow through the TD, D135. 6.16 ma through the TD will switch it to its high state without waiting for a trigger pulse. The completion of one sweep causes the next to begin. The circuit will free run at a rate set by the TIME/CM switch. Q124 is turned on, igniting B124, indicating that the circuit is in the free run mode of operation.

G. Auto Circuit

Figure 20 is the simplified schematic.

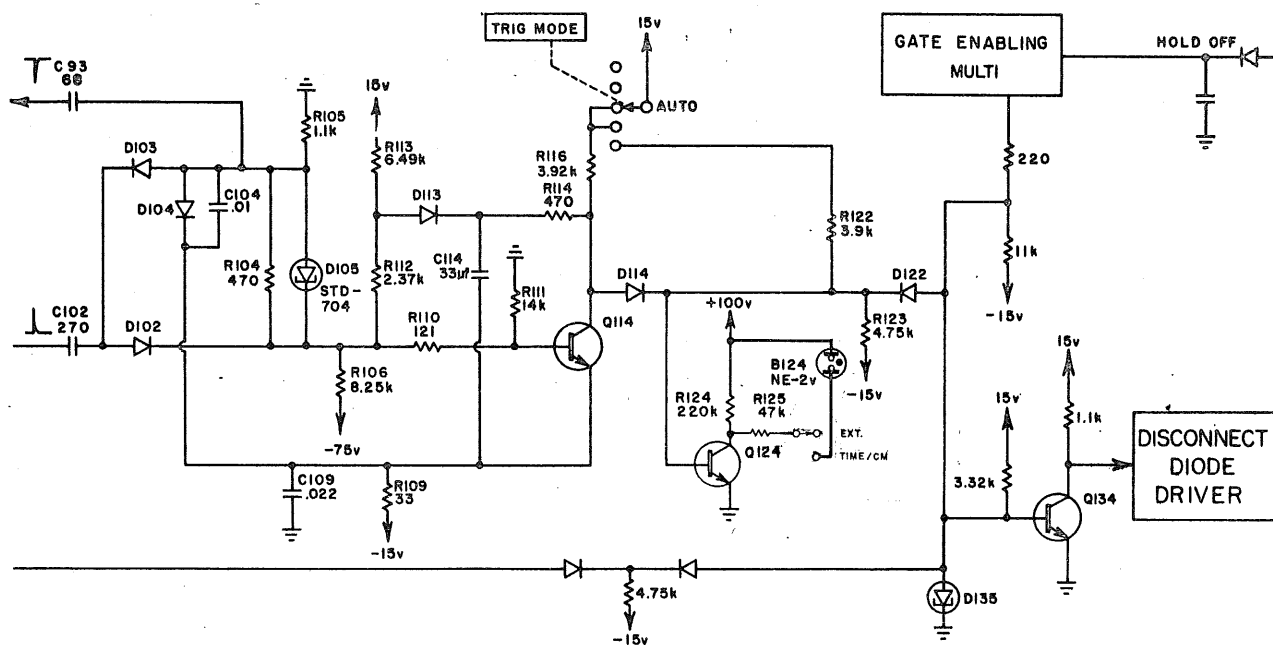

TYPE IIB1 SWEEP GENERATOR  
AUTO MULTI

Fig. 20

B-IIB1-0016x  
12-5-'63 jg

The conduction state of the AUTO circuit determines whether Diode D122 will be forward biased or reversed biased. When D122 is forward biased (trigger signal present at least every 80 msec), the sweep generator operates exactly as described for the NORMAL mode. When D122 is reverse biased (absent of triggering signals), the sweep generator operates as described for the FREE RUN mode.

Quiescently, D105 (a 4.7 ma TD) is in its high state with about 2 ma flowing. Q114 is cut off and its collector voltage is near 0 volts (current) through R123, D114 and R116 to 15 volts). D114 is turned and D122 is cut off. Q124 is turned, igniting B124 which indicates that the sweep generator is in the free run condition, D113 is cut off. D102 and D103 are barely conducting.

Figure 21 is the current distribution in the quiescent condition.

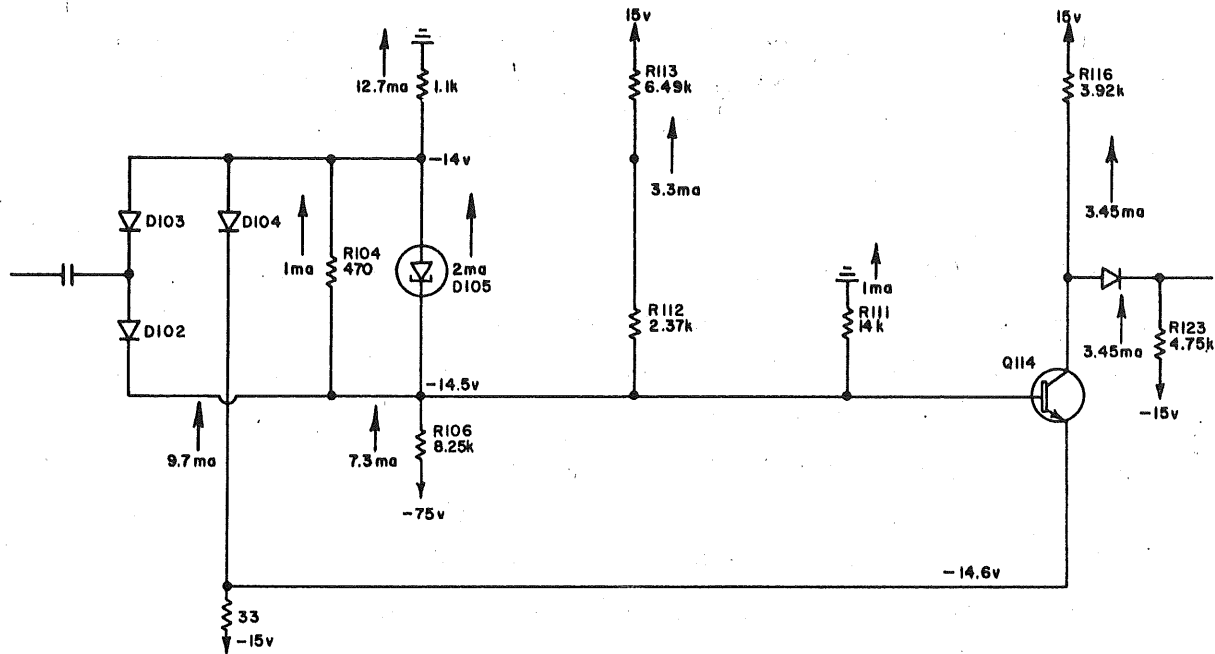

TYPE IIB1 AUTO CIRCUIT  
CURRENT DISTRIBUTION

Fig. 21

B-IIB1-0017x  
1-31-'64 jg

7.3 ma through R106 supplies the TD circuit. 3.3 ma flows through R112 and R113 to 15 volts. 1 ma flows through R111 to ground and 2 ma flows through the TD.

Following is the sequence of operation as a trigger pulse arrives. When a positive going current pulse is applied to C102, D102 is pulled into heavy conduction, diverting current from the tunnel diode, D105. The tunnel diode rapidly switches to its low state causing a positive pulse on its cathode (approximately 500 mv in amplitude). This positive turns on Q114, dropping the collector voltage to about -14 volts, reverse biasing D114, turning on D122 and turning off Q124. With D122 conducting, the sweep generator is in its triggerable state.

As Q114 goes into saturation, the greatest portion of its collector current passes through R114 and discharges C114. When C114 voltage has decreased to approximately -6.4 volts (on the way to -14 volts), D113 will conduct. This will lower the voltage at its anode decreasing current through R112. The R106 current no longer caused by R112 is diverted to the tunnel diode, D105, causing it to flip to its quiescent high state (4.7 ma will flip the TD to its high state).

This will cause Q114 to turn off. Its collector will rise only as fast as C114 can charge toward +15 volts through R114 and R116 in parallel with R113 (through D113). D114 is still cut off and D122 remains on. When C114 has charged to approximately -7 volts, D113 becomes reverse biased and R113 is no longer in parallel with R114 and R116. The divider, R113 and R112, is now at its original quiescent current level, which diverts some current from the TD, D105, allowing it to be triggered again. When the voltage at the collector of Q114 reaches zero volts, D114 becomes forward biased cutting off D122 and the sweep generator is returned to the free running condition. D124 is turned on and B124 is lit, indicating the generator is free running.

To keep D114 cut off and D122 conducting, trigger pulses must arrive at C102 with a repetition rate greater than 20 pulses per second. This will trigger the TD, D105, and prevent C114 from charging sufficiently to turn on D114. With D114 turned off continuously, the sweep generator will operate exactly as it does in the NORMAL mode.

D103 functions as a DC restorer allowing C102 to charge between triggers. D104 provides temperature compensation for Q114 and also maintains a low impedance point for D105 anode. D104 conducts under all conditions. C104 prevents the fast TD switching spikes from cutting off D104. The connection from Q94 trigger generator provides a close loop ground for Q94 emitter bypass capacitor, C93, preventing unwanted ground loops.

### H. Alternate Trace Amplifier

Figure 22 is the simplified diagram.

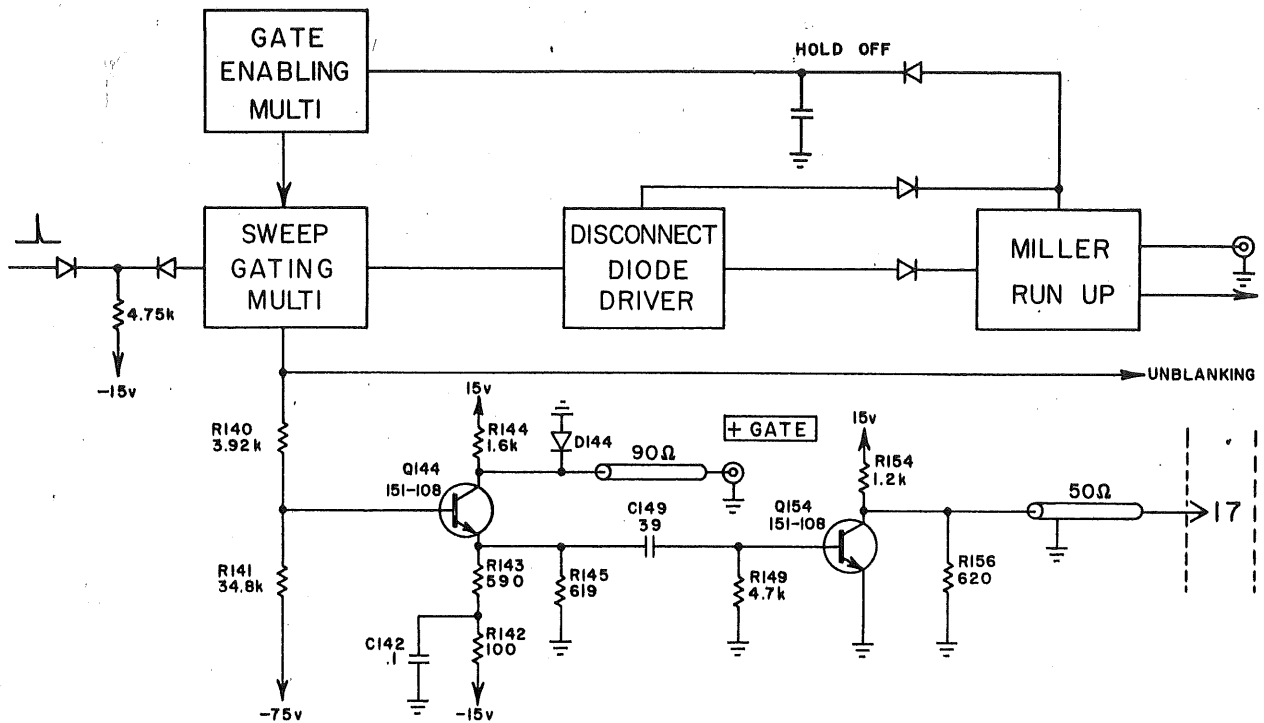

TYPE IIB1 SWEEP GENERATOR  
ALTERNATE TRACE AMPLIFIER

B-IIB1-0018  
1-10-64 jg

Fig. 22

The Alternate Trace Amplifier supplies a negative going 5 volt trigger to the 10A2 dual trace switching circuit. The pulse is fed to pin 17 of the blue ribbon connector. The pulse is coincident with the end of the sweep. The circuit also provides a 15 volt + GATE OUT waveform and a 6.5 volt unblanking pulse.

The waveform at the collector of Q134 supplies the Alternate Trace Amplifier. This 6.5 volt waveform is the unblanking signal and is 0 volts during sweep and +6.5 volts when no sweep occurs. The waveform is attenuated to 5.8 volts peak-to-peak at the base of Q144 (-7.8v during sweep, -2v between sweeps).

Quiescently, Q144 is turned on by the +6.5 volts at the collector of Q134. Q144 conducts heavily but its collector and the + GATE OUT connector output is clamped at -0.6 volts by diode, D144. Q154 is cut off and the voltage on its collector is approximately 5 volts. This voltage is determined by R156 and R154.

At the beginning of the sweep, the collector of Q134 drops to zero volts, cutting off Q144. The collector of Q144 rises to +15 volts. This collector waveform is fed to the front panel + GATE OUT connector.

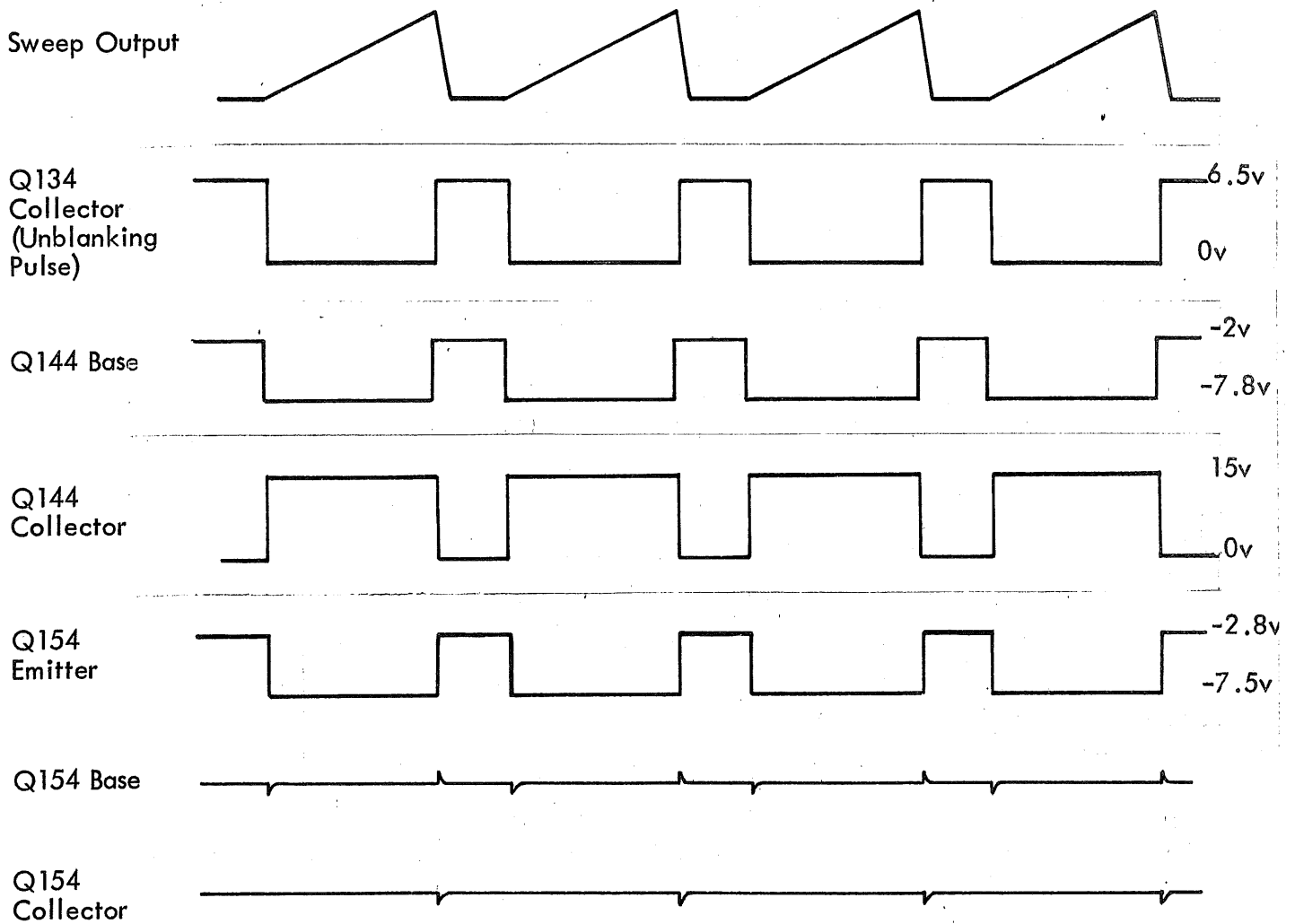

The Q144 emitter waveform is differentiated by C149 and R149 ( $T_c = 183$  nsec). A negative pulse is applied to the base of Q154. The negative pulse has no effect as Q154 was cut off. At the end of the sweep, the collector of Q134 jumps positive to +6.5 volts, turning on Q144 and dropping its collector to -.6 volts. This ends the + GATE signal. The positive pulse at the emitter of Q144 is differentiated and coupled to the base of Q154, turning it on. The collector will drop to zero volts and then decay back to 5 volts as the base signal decays to zero. The signal at the collector is used to trigger the multi-channel vertical plug-in unit during alternate mode of operation.





Type 11B1 Plug-In

IV. HORIZONTAL PREAMP

A. The Horizontal Preamp provides a push-pull sweep ramp and positioning information to the Type 647 Horizontal Amplifier.

1. The output appears at pins 8 and 9, blue ribbon connectors.
2. The output is a current drive ( $347 \mu\text{A}/\text{cm}$  each side) to the Type 647 Horizontal Amplifier.
3. The  $347 \mu\text{A}/\text{cm}$  is standardized for plug-in main frame compatibility.

B. Five MAG positions are available.

C. Basic Circuits

1. Positioning EF.
2. Sweep and EXT Horizontal EF.
3. Paraphase inverter.
4. Grounded base driver amplifier.

D. Block Diagram

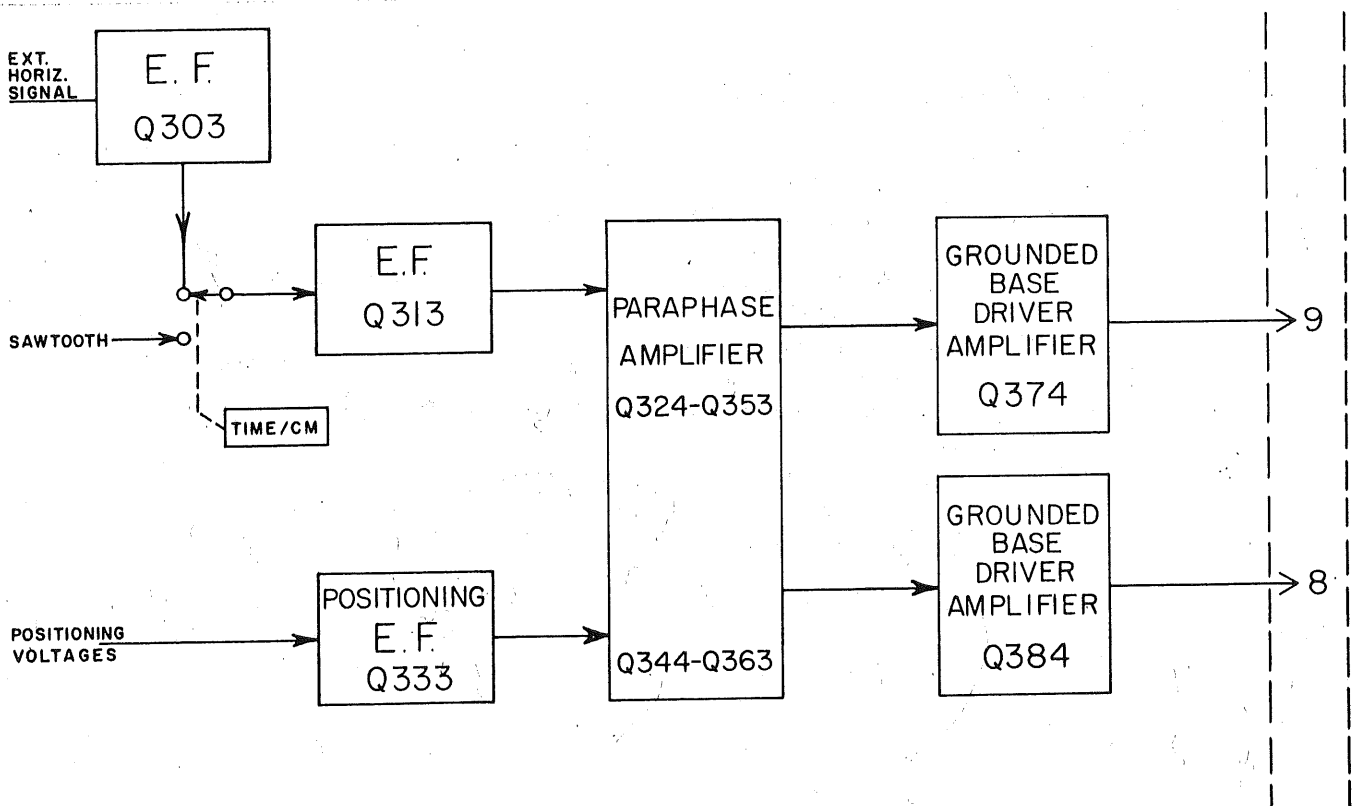

TYPE 11B1 HORIZONTAL PREAMPLIFIER  
BLOCK DIAGRAM

B-11B1-0019  
2-13-64 jg

Type 11B1 Plug-In

E. Positioning EF

1. Provides positioning information to the Paraphase Inverter.

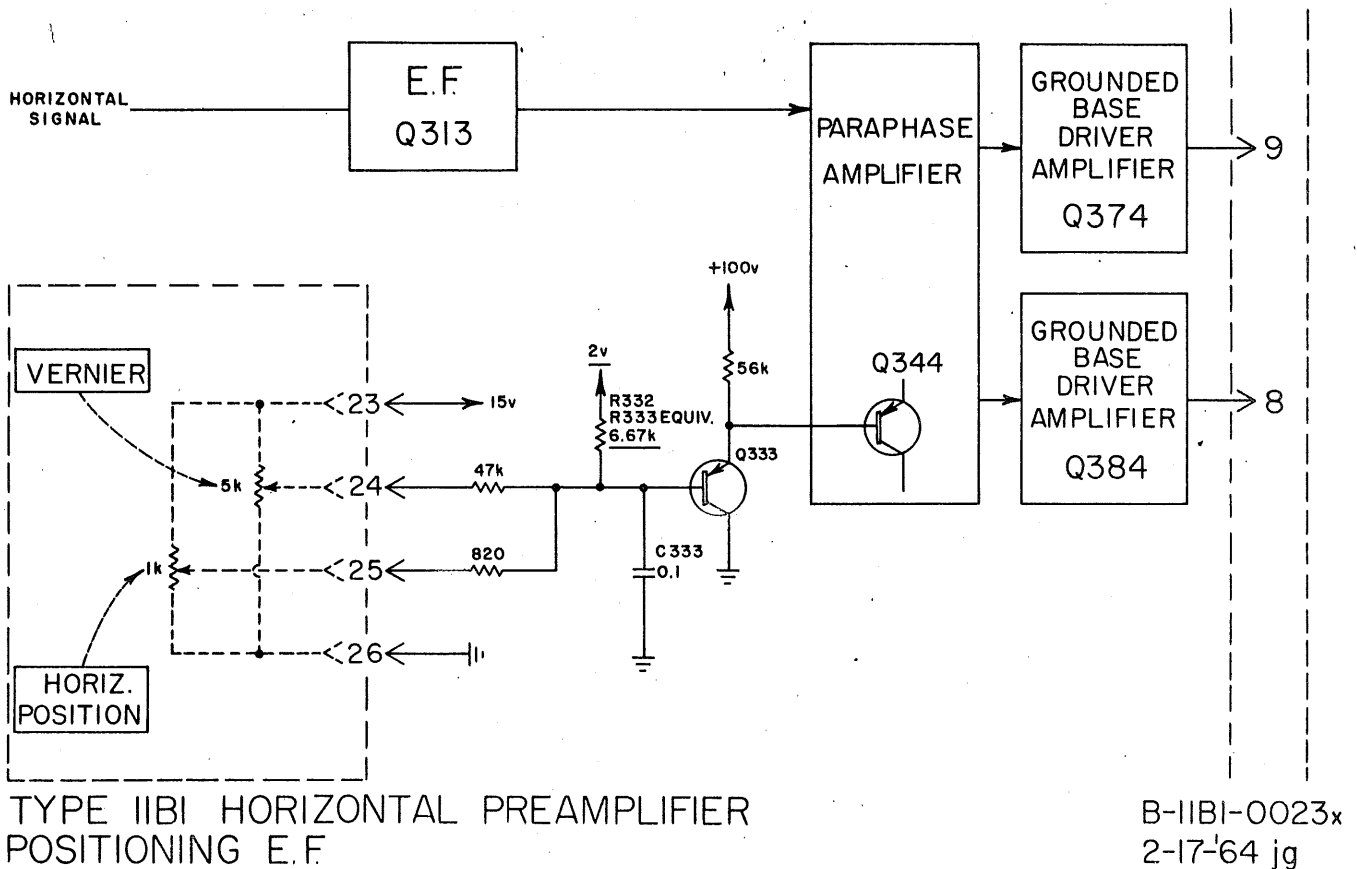

2. Q333 is a TI J3138 silicon PNP transistor.
3. Positioning information from the Type 647 main frame appears at pins 24 and 25 of the blue ribbon connector.
  - a. Each positioning control has a swing at pins 24 and 25 of 0v to -15v.
  - b. The HORIZ POSITION control can swing the beam (EXT HORIZ INPUT MODE) 13 cm.
  - c. The VERNIER control swings the beam 2.5 mm.
  - d. Horizontal positioning sensitivity is subject to MAG positions.

Type 11B1 Plug-In

- 4. HORIZ POSITION and VERNIER control rotational sensitivity is set by the 47k and 820Ω resistors and R333 and R332.
  - a. R332 and R333 form an equivalent circuit of 6.7k to 2v.
- 5. Q333 voltages with the beam at 0 cm and 10 cm.
  - a. Q333 base, 11.5v to 1.8v.
  - b. Q333 emitter, 12v to 2.5v.
- 6. Q333 voltages with the beam at 5 cm.
  - a. Q333 base, 6.6 v.
  - b. Q333 emitter, 7.2v.
- 7. C333 bypasses pot noise from the positioning controls.

F. Sweep and EXT INPUT EF

- 1. Delivers Sweep and EXT HORIZ information to Paraphase Inverter.

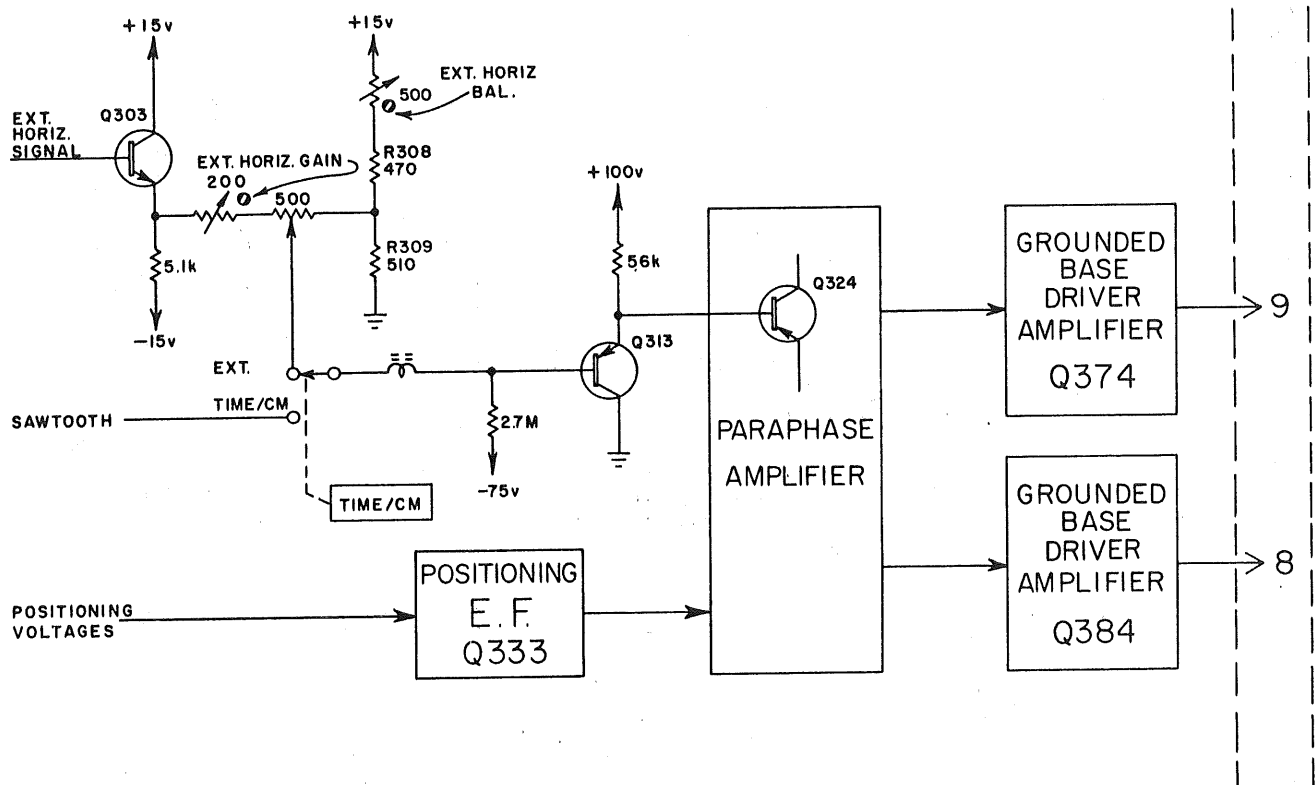

TYPE 11B1 HORIZONTAL PREAMPLIFIER  
SWEEP AND EXT. HORIZONTAL E.F.

B-11B1-0020x  
2-13-'64 jg

## Type 11B1 Plug-In

2. Q303 is a 151-103 silicon NPN transistor.
3. Q313 is a TI J3138 silicon PNP transistor.
4. Two inputs are available selected by the TIME/CM switch.
  - a. The sweep ramp from the Sweep Generator.
  - b. EXT HORIZ INPUT from the Trigger Generator.
5. The EXT HORIZ INPUT has a sensitivity of 5 v/cm.
  - a. Accurate for 3 cm each side of center screen when used in unmarked 5v/div sensitivity.
  - b. The magnifier adds sensitivities of .1, .2, .5, 1 and 2 v/cm accurate to within 3% for full screen.
6. An EXT HORIZ voltage is 7.4v at Q303 base to place the beam at 5 cm.
  - a. Q303 base is 12v at 10 cm.
7. Emitter follower Q303 provides gain to drive the EXT HORIZ GAIN controls.
8. The EXT HORIZ GAIN adj is a calibration adj to set EXT HORIZ sensitivity.
9. The VARIABLE GAIN control (ganged with VARIABLE TIME/CM) has a range of 3.5:1.
10. The EXT HORIZ BAL sets the DC level at R308-309 junction equal to that at Q303 emitter under no-signal conditions.
  - a. No current flowing through the VARIABLE control assures no trace shift when it is rotated.
11. EF Q313 provides a drive to the Paraphase Inverter consistent with that offered by the Positioning EF, Q333.
  - a. A ferrite bead in the base lead prevents oscillations.

Type 11B1 Plug-In

- 12. The 2.7M resistor to Q313 base supplies average base current.
  - a. For the average transistor, no base current flows through the VARIABLE arm.
  - b. For other than average transistors, the VARIABLE control presents a varying resistance with some resulting trace shift.

G. PARAPHASE INVERTER

- 1. The Paraphase Inverter converts Positioning Sweep and EXT HORIZ INPUT signal voltages to push-pull signal current to drive the Type 647 Horizontal Amplifier.

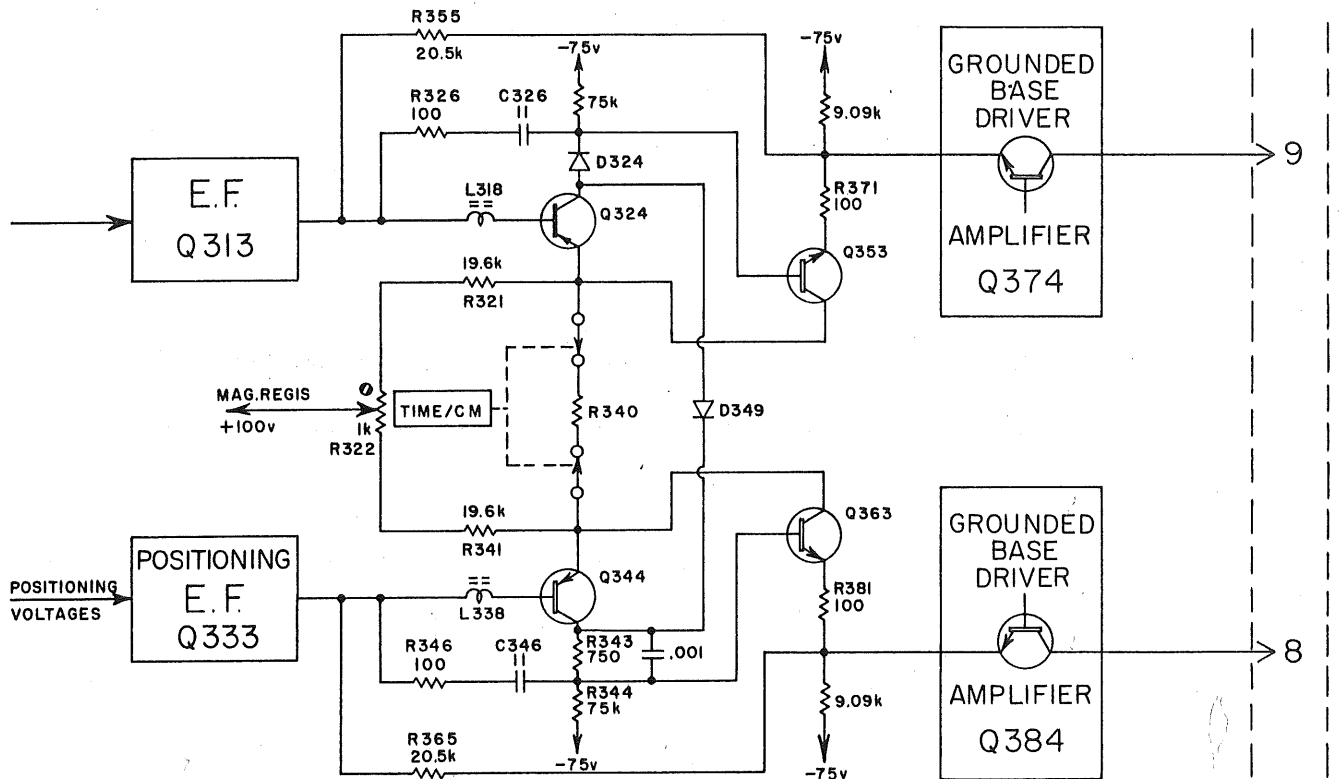

TYPE 11B1 HORIZONTAL PREAMPLIFIER  
PARAPHASE AMPLIFIER

B-11B1-0021x  
2-14-64 jg

Type 11B1 Plug-In

2. Design is complicated by X50 magnification.
  - a. Gain is a function of emitter tying resistors R340.
  - b. Transistor pair \*Q324, Q353 (and Q344, Q363) form a high gain stage whose gain is only slightly dependent upon the emitter resistance of Q324 (Q344).
3. Since the Paraphase Inverter converts from voltage drive to current output, the stage can be said to have a trans-admittance gain. The gain is 347  $\mu\text{a}/\text{volt}$  for X1 MAG.

a. Trans-admittance gain =  $\frac{\Delta \text{Output Current}}{\Delta \text{Input Voltage}}$

b.  $A_y = \frac{\Delta i_o}{\Delta e_i}$

When:  $A_y$  is trans-admittance gain.

$\Delta i_o$  is the output current.

$\Delta e_i$  is the input voltage.

c.  $A_y = \frac{3.47 \text{ ma}}{10 \text{ ma}}$   
 $= 347 \mu\text{a}/\text{volt}$

4. Allowing for loss in the CF (Trigger Generator diagram) and loss from Q374, Q384 base current, the input voltage appears across R340 and the output current flows through R340.
  - a. Since trans-admittance is the ratio of output current to input voltage;
  - b. The trans-admittance =  $\frac{1}{R}$  where R is the MAG resistor.
  - c. In the X1 MAG position:

$$R = \frac{1}{T_y}$$
$$= \frac{1}{347 \mu\text{a}}$$

$$= 2.88\text{k} \text{ (actual value is 2.67k)}$$

\* See June 1963 Service Scope, Circuit 11.

Type 11B1 Plug-In

d. In the X50 position:

$$\begin{aligned} R &= \frac{1}{T_y \times 50} \\ &= \frac{1}{347 \mu\text{a} \times 50} \\ &= 53\Omega \end{aligned}$$

5. Trans-admittance gain of the amplifier, therefore, is a function of the switched Magnifier resistors and independent of emitter resistance.
6. Input voltage appears across emitter current return resistors R321, R341 and the MAG REGIS control.
  - a. Some signal current, therefore, flows through these resistors.
  - b. Feedforward resistors R355 and R365 cancel the signal current flowing in R321 and R341 making gain dependent only on MAG resistors.
  - c. Note that R355 is equal to R321 and half R322.
  - d. Since signal current through the emitter return resistors is canceled, this amplifier is not subject to the common-mode signal unbalance inherent in paraphase inverters\*.
7. The Magnifier requires limiting circuits as the beam is driven far off screen before the sweep.
  - a. Prior to sweep, these circuits limit the output to about 10 cm left of screen center (5 cm off screen).
8. Output current at screen center is 2.55 ma.
  - a. With the beam at screen center, Q374 emitter is at -2.25v.
  - b. By virtue of the drop across R371, Q353 base emitter junction drop and the drop across D324, Q324 collector is about -.4v.
  - c. The drop across R381, Q363 base, emitter junction and the 750Ω R places Q344 collector at -.25v.
  - d. The limiting diode, D349, is cut off.

\* See page 85 and 86, 11B2 Notes.

## Type 11B1 Plug-In

9. Prior to sweep (in MAG position), Q324 collector is at 0v and Q344 collector sets at  $-.625v$ .
  - a. D349 conducts as Q344 cuts off.
  - b. The 1 ma static collector current now flows through D349.
  - c. Q324 now conducts 2 ma.
10. A combination of Q344 emitter voltage prior to sweep and positioning voltage on the base can cause Q344 to zener.
  - a. Q344 zeners at 7v.
  - b. Zener current is limited by R344 at less than a ma so the transistor is not damaged.
11. D324 provides a voltage drop and temperature compensation for D349.
12. Mag resistors are 1/2% except in the X1 position where a 1/10% resistor is used.
  - a. R371, R381, R343 are 1% resistors.
  - b. This resistor tolerance assures accuracy of the left of screen limiting action of the amplifier.
13. R326, C326 (and R346, C348) compensate for stray C across R340.
  - a. Switch capacitance in the MAG switch provides too much HF peaking.
  - b. The feedback RC network reduces gain at these frequencies to compensate.
14. L318, L338 suppress parasitics.
15. The MAG REGIS adj allows adjustment to assure that the center of the sweep appears at the center of the graticule at all MAG positions.



Type 11B1 Plug-In

H. DRIVER AMPLIFIER

1. The grounded base push-pull stage provides a high impedance current drive for the Type 647 Horizontal Amplifier.

a. Input Z is low.

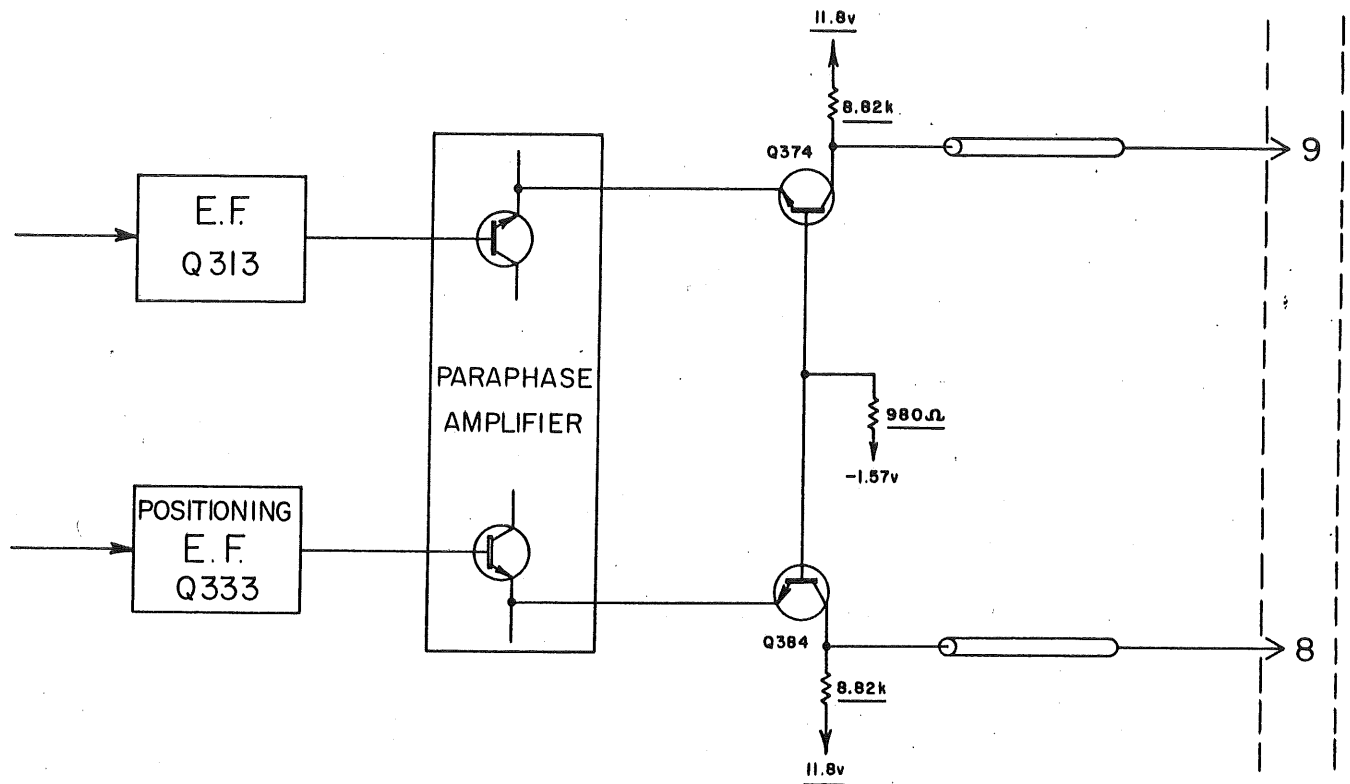

TYPE IIB1 HORIZONTAL PREAMPLIFIER  
OUTPUT DRIVERS

B-IIB1-0022  
2-15-64 jg

2. Q374 and Q384 are 151-108 selected Motorola 2N2501 silicon NPN transistors.
3. Collector load equivalent resistance is 8.82k to 11.8v.
4. Base current return equivalent resistance is 980 ohms to -1.57v.



# CONTENTS-MAINTENANCE

## MODIFICATIONS

Modification summary  
Strip layout

## MAINTENANCE NOTES

Small hardware corrosion problems, 1-15-65  
Surface crazing of knobs, 2-15-65  
Corrosion of composition resistor leads, 1-15-65  
Use of Hitachi Nuvistors in environmentalized instruments, 10-1-65

## PARTS

## CALIBRATION

Graphic calibration procedure  
Short form graphic calibration procedure  
Maintenance and calibration (manual)  
"Calibration adjustment locations"

## SCHEMATICS



# MODIFICATION SUMMARY

11B1



© 1965, Tektronix, Inc.  
All Rights Reserved.





SWEEP GATING AMPLIFIER RESISTOR  
CHANGED TO LENGTHEN SWEEP

See SQB

\*\* PILOT-2

Effective Prod s/n 140

Usable in field instruments s/n 100-139

DESCRIPTION:

Increases the length of the sweep to optimize sweep starting voltage. This is accomplished by changing R163 (Sweep Gating Amplifier, Q164, bias resistor) from a 205Ω 1/8 w 1% resistor to a 178Ω 1/8 w 1% resistor.

Parts Removed:

R163 205Ω 1/8 w 1% 321-0127-00

Parts Added:

R163 178Ω 1/8 w 1% 321-0121-00

INSTALLATION INSTRUCTIONS:

Replace R163 located between ceramic strip notch and ground near D163 and Q164 with a 178Ω 1/8 w 1% resistor 321-0121-00.

HORIZ PREAMP TRANSISTORS Q324  
AND Q344 CHANGED DUE TO LACK  
OF AVAILABILITY

See SQB

M8537

Effective Prod s/n 190

Usable in field instruments s/n 100-189

DESCRIPTION:

MM999 selected transistor replaces FT1746 transistors which are no longer available. Associated circuit changes were also made.

Parts Replacement Kit 050-0224-00 is available to facilitate the replacement of Q324 and Q344 in pre-effective s/n instruments.

Parts Removed:

C326,C346 11 pf 281-0537-00  
Q324,Q344 FT1746 151-0122-00

Parts Added:

C326,C346 15 pf 281-0509-00  
Q324,Q344 MM999\* 151-0133-00

INSTALLATION INSTRUCTIONS:

Refer to Parts Replacement Kit 050-0224-00 for replacement of transistors Q324 and Q344.

\*Tek spec., slightly relaxed from full MM999 spec. 2N3251 selected for  $C_{ob} \leq 4 \text{ pF}$  may also be used.

\*\* Pilot-1, 2, etc, designate modification installed in Pilot Production that was not assigned a standard mod number.

LEVER KNOB MATERIAL CHANGED TO  
ELIMINATE DEFORMITY UNDER  
CERTAIN ENVIRONMENTAL CONDITIONS

See SQB

M9262

Effective Prod s/n 210

Usable in field instruments s/n 100-209

**DESCRIPTION:**

Changes the type of material used in the manufacture of the lever knob, from a charcoal gray cycolac X7 styrene to charcoal gray Delrin\* 500. The delrin 500 lever knobs will not deform when subjected to environmental conditions.

**Parts Removed:**

**Parts Added:**

Knob, lever, styrene (3) 366-0215-00

Knob, lever, delrin 500 (3) 366-0215-01

**Parts Required for Field Installation:**

See 'Parts Added'.

**INSTALLATION INSTRUCTIONS:**

Replace the three lever knobs with the new 366-0215-01 lever knobs.

\*Du Pont, Registered Trademark.

DIODES REPLACED WITH LOWER  
COST UNITS HAVING SIMILAR  
CHARACTERISTICS

INFORMATION ONLY

M9342

Effective Prod s/n 210

FRONT PANEL SYMPTOM: None.

PROBLEM: A less expensive diode was available for a direct replacement of the type 1N3605 in many applications.

PRODUCTION CHANGE: Diodes were changed from type 1N3605 (152-0141-00) to 152-0185-00, which is the same 1N3605 diode with relaxed specifications.

**Parts Removed:**

D43, D44, D46, D52, )  
D56, D66, )  
D113, D114, D122, )  
D144, D163, D165, )  
D172, D183, D200, )  
D201, D203, D213, )  
D242, D324, D349 )

1N3605 Diode

152-0141-00

**Parts Added:**

D43, D44, D46, D52, )  
D56, D66, )  
D113, D114, D122, )  
D144, D163, D165, )  
D172, D183, D200, )  
D201, D203, D213, )  
D242, D324, D349 )

Relaxed 1N3605 Diode

152-0185-00



AUTO TRIGGERING IMPROVED FOR LINE AND OTHER LF TRIGGERING SIGNALS

See SQB

M10445

Effective Prod s/n 310

Usable in field instruments s/n 100-309

FRONT PANEL SYMPTOM: Jitter or free-running trace in Automatic with line or other 100 p/s (or less) triggers; would be particularly troublesome with 50 Hz line.

PROBLEM: Test was selecting Q94 in order to obtain stable Auto-Line mode triggering. The drive from Q94 was frequently insufficient to reset the Auto circuit if it was near the end of its timing cycle.

PRODUCTION CHANGE: C93, was changed from 68pF to 82pF; R91 from 100Ω to 47Ω and Q94 from 2N967 to 2N964 for improved Auto triggering on low frequency signals.

Parts Removed:

C93	Capacitor, 68pF 500V 10%	281-0549-00
R91	Resistor, comp, 100Ω 1/4W 10%	316-0101-00
Q94	Transistor, 2N967	151-0107-00

Parts Added:

C93	Capacitor, 82pF 500V 10%	281-0528-00
R91	Resistor, comp, 47Ω 1/4W 10%	316-0470-00
Q94	Transistor, 2N964	151-0131-00

INSTALLATION INSTRUCTIONS:

Parts Required: See 'Parts Added'.

Installation Procedure: Refer to the drawing for component locations.

- a) Replace Q94 with a 2N964 transistor.
- b) Replace C93 located between CSE-22 and CSE-28 with an 82pF 500V 10% ceramic capacitor.
- c) Replace R91 located between CSE32 and base pin of Q94 with a 47Ω 1/4W 10% resistor.

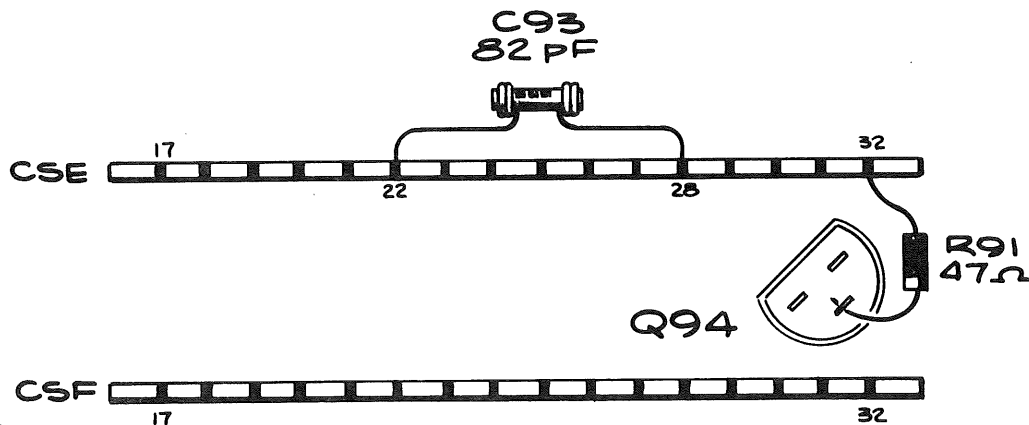

TIMING CAPACITOR CHANGED  
TO ELIMINATE DUPLICATION  
OF PART NUMBERS

INFORMATION ONLY

M8746

Effective Prod s/n 320

DESCRIPTION:

Provides a cost savings by changing the timing series capacitors to a type presently being used. The new series is identical to the old except for heavier 18 gauge leads on the 1.0  $\mu\text{F}$  unit. Location is on the Time/CM switch 262-0635-00.

Parts Removed:

	0.001 $\mu\text{F}$	
	0.01 $\mu\text{F}$	
C180E-J	0.1 $\mu\text{F}$	295-0072-00
	1.0 $\mu\text{F}$	
	10.0 $\mu\text{F}$	

Parts Added:

	0.001 $\mu\text{F}$	
	0.01 $\mu\text{F}$	
C180E-J	0.1 $\mu\text{F}$	295-0082-00
	1.0 $\mu\text{F}$	
	10.0 $\mu\text{F}$	

OUTPUT PREAMP BASE CIRCUIT CHANGED  
TO ELIMINATE 70 MHz OSCILLATION  
IN VERTICAL

See SQB

M10995

Effective Prod SN 460  
w/exceptions 312, 314-5, 350, 422, 434

Usable in field instruments SN 100-459

FRONT PANEL SYMPTOM: 70 MHz vertical oscillations often in line frequency related bursts, with RM647/11B1. Amplitude varies with astigmatism control setting.

PROBLEM: 70 MHz common mode oscillation in RM647/11B1 Horizontal Amplifiers, which apparently uses the CRT circuitry and cabling for a feedback path.

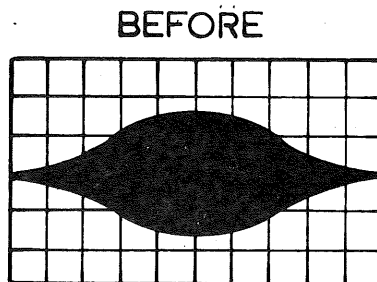

PRODUCTION CHANGE: Capacitor C389 was removed from the instrument. Ferramic inductor L389 was added over the base lead of Q374, to help eliminate the 70 MHz oscillation. Also, see 10A1 and RM647 (M10995) production change.

Parts Removed:

C389	Capacitor, ceramic 0.001 $\mu\text{F}$	283-0078-00
------	--	-------------

Parts Added:

L389	Core, ferramic suppressor	276-0507-00
------	---------------------------	-------------

INSTALLATION INSTRUCTIONS:

Parts Required: See 'Parts Added'.

continued

Installation Procedure: Refer to drawing for all steps.

- a) Remove capacitor C389 (0.001  $\mu$ F 500 V), located between CSA-13 and CSB-13.
- b) Unsolder the CSA-14 end of a bare wire connected between CSA-14 and base of Q374.
- c) Insert a ferramic suppressor (L389) over the wire and solder to CSA-14.

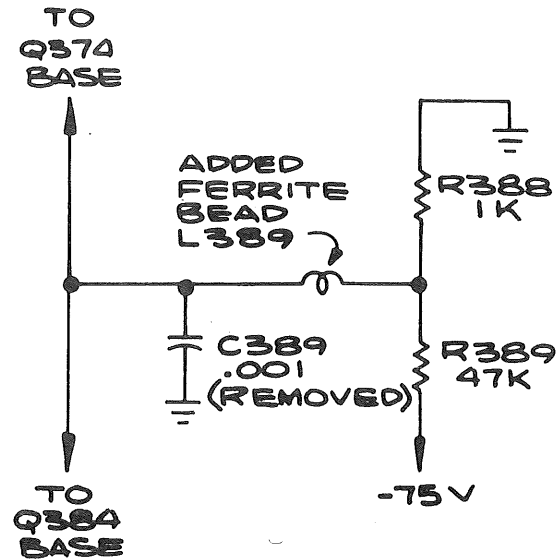

HORIZONTAL PREAMP (PARTIAL)

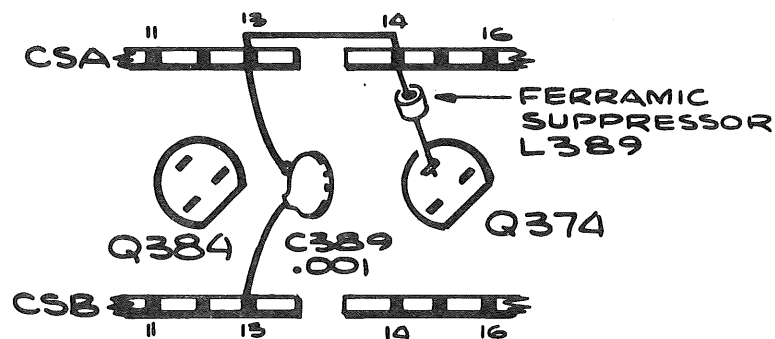

TRIGGER INPUT PROTECTION  
DIODE CHANGED TO TYPE  
MORE EASILY OBTAINABLE

See SQB

M10778

Effective Prod SN 520

Usable in field instruments SN 100-519

FRONT PANEL SYMPTOM: None.

PROBLEM: Vendor is unable to supply the quantity of type 6045 diodes required for use in instrument types 11B1.

PRODUCTION CHANGE: Diodes D38 and D39, were replaced with 152-0246-00 silicon signal diodes.

Parts Removed:

D38, D39	Diode 6045 (2)	152-0045-00
----------	----------------	-------------

Parts Added:

D38, D39	Diode, silicon, signal	152-0246-00
----------	------------------------	-------------

INSTALLATION INSTRUCTIONS:

Parts Required: See 'Parts Added'.

Installation Procedure:

NOTE: Banded end of diode is the cathode.

Replace diodes D38 and D39 (when defective), located between ceramic strips directly above V43, with 152-0246-00 signal diodes.

10% AND 20% ZENER DIODE  
CHANGED TO STANDARD 5% UNIT

INFORMATION ONLY

M11191

Effective Prod SN 730

FRONT PANEL SYMPTOM: None.

PROBLEM: Zener diode values are at present widely scattered in both voltage and tolerance. The proposed modifications will standardize all 400 mW 1 W 1.5 W and 10 W Zeners, now listed as 10 and 20% to 5% tolerance, and change the majority of non-standard parts to standard JEDEC units. One of these changes is to minimize the number of active part numbers. There will be no increase in cost for the 5% Zeners.

PRODUCTION CHANGE: Voltage tolerance for 10% and 20% Zener diodes was changed to 5% for all uses. At the same time, all 250 mW Zener diodes were changed to 400 mW. Refer to parts removed and added list for details.

Parts Removed:

D47	Diode, 1N751 5.1 V ±10%	152-0139-00
-----	-------------------------	-------------

Parts Added:

D47	Diode, 1N751A 5.1 V ±5%	152-0279-00
-----	-------------------------	-------------

JB:bl

# MAINTENANCE NOTES

## SMALL HARDWARE CORROSION PROBLEMS IN HUMIDITY TESTS

FEN 1-15-65

An impending cadmium shortage and a government circular encouraging the use of zinc for corrosion-resistance prompted a widespread changeover to zinc-plated screws, nuts, bolts and other hardware items. Zinc being a "sacrificial" metal in electrolysis, its use in equipment where the zinc surface area is much smaller than the other metal surface areas unfortunately promotes rapid destructive corrosion of the zinc-plated parts, loss of the zinc protection, and rusting, under conditions of severe humidity, salt spray, etc. This was confirmed in humidity tests on the RM647 at Lawrence Radiation Laboratory last fall, and hardware parts for the 647 systems were converted back to cadmium plate. The conversion from zinc back to cadmium was as complete as possible, effective at the following serial numbers:

647	S/N	620
RM647		290
10A2		740
11B2		660
11B1		210

Special attention is being given to the plated castings in the 647 and 10A2; their base metal contains zinc and cannot be easily changed; however, with sufficient care in the plating, they should survive 5-day humidity tests without serious problems.

(Non-environmentalized instruments will temporarily stick with zinc-plated hardware -- identified by its bluish color -- until sufficient cadmium-plated hardware is in stock to cover all production. The zinc hardware should not cause problems in normal environments.)

---

## SURFACE CRAZING OF KNOBS AFTER TEMPERATURE-HUMIDITY CYCLING

FEN 1-15-65

The polished surface of Tek-made knobs shows a light surface crazing after prolonged temperature-humidity cycling. We're not sure it's easily cured, but so far as we know, it's purely an appearance problem.

---

## CORROSION OF COMPOSITION RESISTOR LEADS DURING HUMIDITY TESTS

FEN 1-15-65

Composition resistors used have a high-lead (95%) coating on the leads. This high lead coating is more susceptible to corrosion than a tin-lead solder. In high humidity environments minute amounts of residual solder flux, plasticizers, etc., may cause a white fuzz to grow on some resistor leads. This appears to be a mixture of lead carbonate and lead oxide. (This effect is not caused by the walnut

blast removal of any tin coating as suggested by one customer.) We have consulted with the vendor but he has offered little guidance, other than suggesting hot-tin dipping all these leads. This has not been a widespread problem, nor do we know of any malfunctions caused by this corrosion; we have not as yet considered a brand change, because of other important differences between various brands.

USE OF HITACHI NUVISTORS IN ENVIRONMENTALIZED INSTRUMENTS

Geoff Gass, 10-1-65

Hitachi Nuvistors made before June, 1965 having copper-colored leads should not be used in instruments subject to humidity-testing or to high humidity storage or use environments. The pin material in contact with the sockets tends to corrode, producing intermittent or high-resistance contact. (The same is true of some early RCA Nuvistors, but not of those made since Nuvistors have been used in Tek environmentalized instruments).

The information about Hitachi Nuvistors was contained in a now -obsolete PRB green sheet dated 6-17-65 for the affected instruments.

Current deliveries of Hitachi Nuvistors to Tek have been modified with a silvery finish of nickel-alloy on the pins and a protective coating at the tips where the pins are cut off. Tek evaluation shows that their corrosion resistance is now equal or superior to RCA's, and the Hitachi's are now acceptable for use in environmentalized instruments.

We don't know when -- or whether -- Hitachi plans to modify Nuvistors sold through other channels, so the approval only extends presently to the ones we get direct.

# PARTS REPLACEMENT KIT

## TRANSISTORS

For the following Tektronix Time Base Units:

Type 11B1 serial numbers 100-189

Type 11B2 serial numbers 100-569

### DESCRIPTION

MM999 selected transistor (151-133) replaces 2N964 transistor (151-131) and FT1746, selected transistor (151-122) which are no longer available.

The MM999 transistor is a direct replacement in the 11B2. Minor circuit changes are made to allow the use of the MM999 transistor in the 11B1.

NOTE: If the serial number of your instrument is above those listed, or if this kit has already been installed, disregard the instructions as P/N 151-133 is a direct replacement.



# 050-224

Publication:  
Instructions for 050-224  
November 1964

© 1964, Tektronix, Inc.  
All Rights Reserved.



**050-224**

Page 1 of 3

PARTS LIST

Quantity	Description	Part Number
2 ea.	Transistor, MM999	151-133
2 ea.	Capacitor, ceramic	281-509

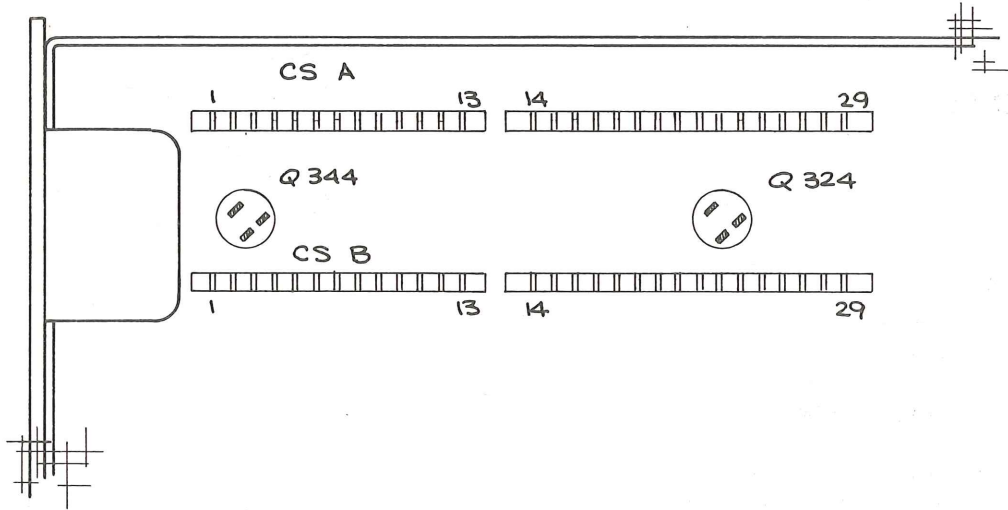

Fig. 1

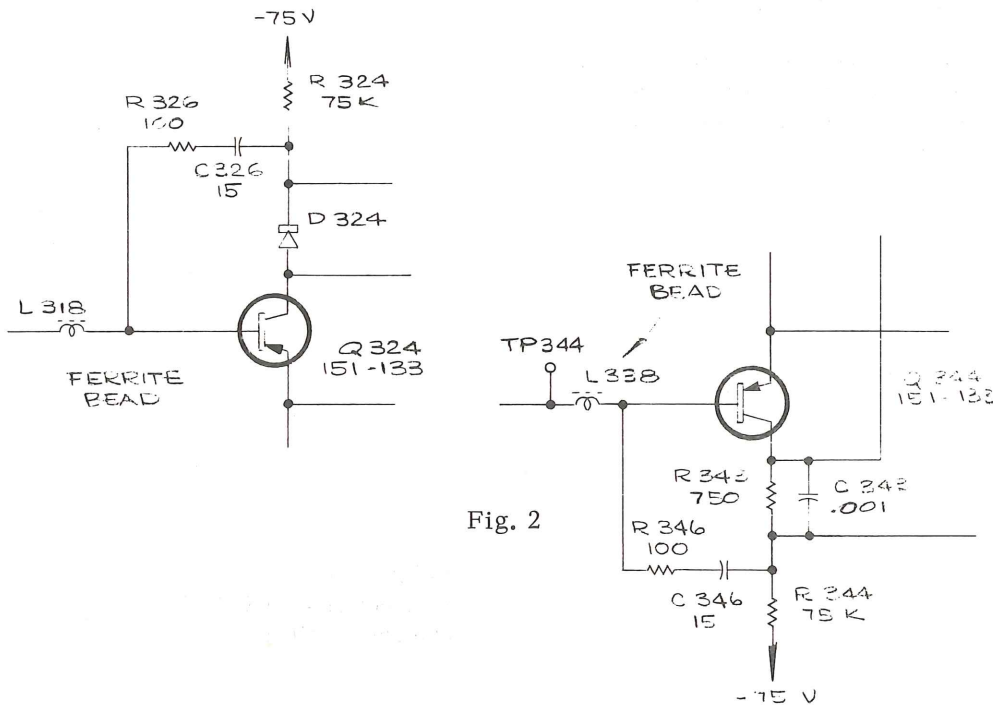

Fig. 2



## INSTRUCTIONS

- ( ) 1. Replace one pair of 151-122 transistors, or 151-131 transistors with one pair of 151-133 transistors as follows:

### TYPE 11B1

- ( ) 2. Q324 and Q344.

NOTE: The 151-133 transistors are a direct replacement except as shown in steps 3 through 8.

REFER TO FIG.1 WHILE PERFORMING STEPS 3 THROUGH 8.

- ( ) 3. Remove C326, an 11 pf capacitor between CSB-23 and CSA-24.
- ( ) 4. Remove C346, an 11 pf capacitor between CSA-2 and CSA-4.
- ( ) 5. Relocate the end of R326, an  $100\ \Omega$  1/4 w resistor that is connected to CSB-24, to the base of Q324.

- ( ) 6. Relocate the end of R346, an  $100\ \Omega$  1/4 w resistor that is connected to CSB-2, to the base of Q344.

- ( ) 7. Install C326, a 15 pf capacitor (from kit) between CSA-24 and CSB-23.

- ( ) 8. Install C346, a 15 pf capacitor (from kit) between CSA-2 and CSA-4.

### TYPE 11B2

- ( ) 9. Q195A and Q195B.

THIS COMPLETES THE INSTALLATION.

- ( ) Recheck your work.
- ( ) For future reference, correct your Instruction Manual Parts List and Horizontal Preamp schematic as required.
- ( ) Refer to the Maintenance Section of your Instruction Manual and recalibrate your instrument as required.

JT:ceb



# SECTION 5

## PARTS LIST AND DIAGRAMS

### PARTS ORDERING INFORMATION

Replacement parts are available from or through your local Tektronix Field Office.

Changes to Tektronix instruments are sometimes made to accommodate improved components as they become available, and to give you the benefit of the latest circuit improvements developed in our engineering department. It is therefore important, when ordering parts, to include the following information in your order: Part number including any suffix, instrument type, serial number, and modification number if applicable.

If a part you have ordered has been replaced with a new or improved part, your local Tektronix Field Office will contact you concerning any change in part number.

### ABBREVIATIONS AND SYMBOLS

a or amp	amperes	mm	millimeter
BHS	binding head steel	meg or M	megohms or mega ( $10^6$ )
C	carbon	met.	metal
cer	ceramic	$\mu$	micro, or $10^{-6}$
cm	centimeter	n	nano, or $10^{-9}$
comp	composition	$\Omega$	ohm
cps	cycles per second	OD	outside diameter
crt	cathode-ray tube	OHS	oval head steel
CSK	counter sunk	p	pico, or $10^{-12}$
dia	diameter	PHS	pan head steel
div	division	piv	peak inverse voltage
EMC	electrolytic, metal cased	plstc	plastic
EMT	electrolytic, metal tubular	PMC	paper, metal cased
ext	external	poly	polystyrene
f	farad	Prec	precision
F & I	focus and intensity	PT	paper tubular
FHS	flat head steel	PTM	paper or plastic, tubular, molded
Fil HS	fillister head steel	RHS	round head steel
g or G	giga, or $10^9$	rms	root mean square
Ge	germanium	sec	second
GMV	guaranteed minimum value	Si	silicon
h	henry	S/N	serial number
hex	hexagonal	t or T	tera, or $10^{12}$
HHS	hex head steel	TD	toroid
HSS	hex socket steel	THS	truss head steel
HV	high voltage	tub.	tubular
ID	inside diameter	v or V	volt
incd	incandescent	Var	variable
int	internal	w	watt
k or K	kilohms or kilo ( $10^3$ )	w/	with
kc	kilocycle	w/o	without
m	milli, or $10^{-3}$	WW	wire-wound
mc	megacycle		

### SPECIAL NOTES AND SYMBOLS

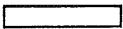
X000	Part first added at this serial number.
000X	Part removed after this serial number.
*000-000	Asterisk preceding Tektronix Part Number indicates manufactured by or for Tektronix, or reworked or checked components.
Use 000-000	Part number indicated is direct replacement.
	Internal screwdriver adjustment.
	Front-panel adjustment or connector.

EXPLODED VIEW

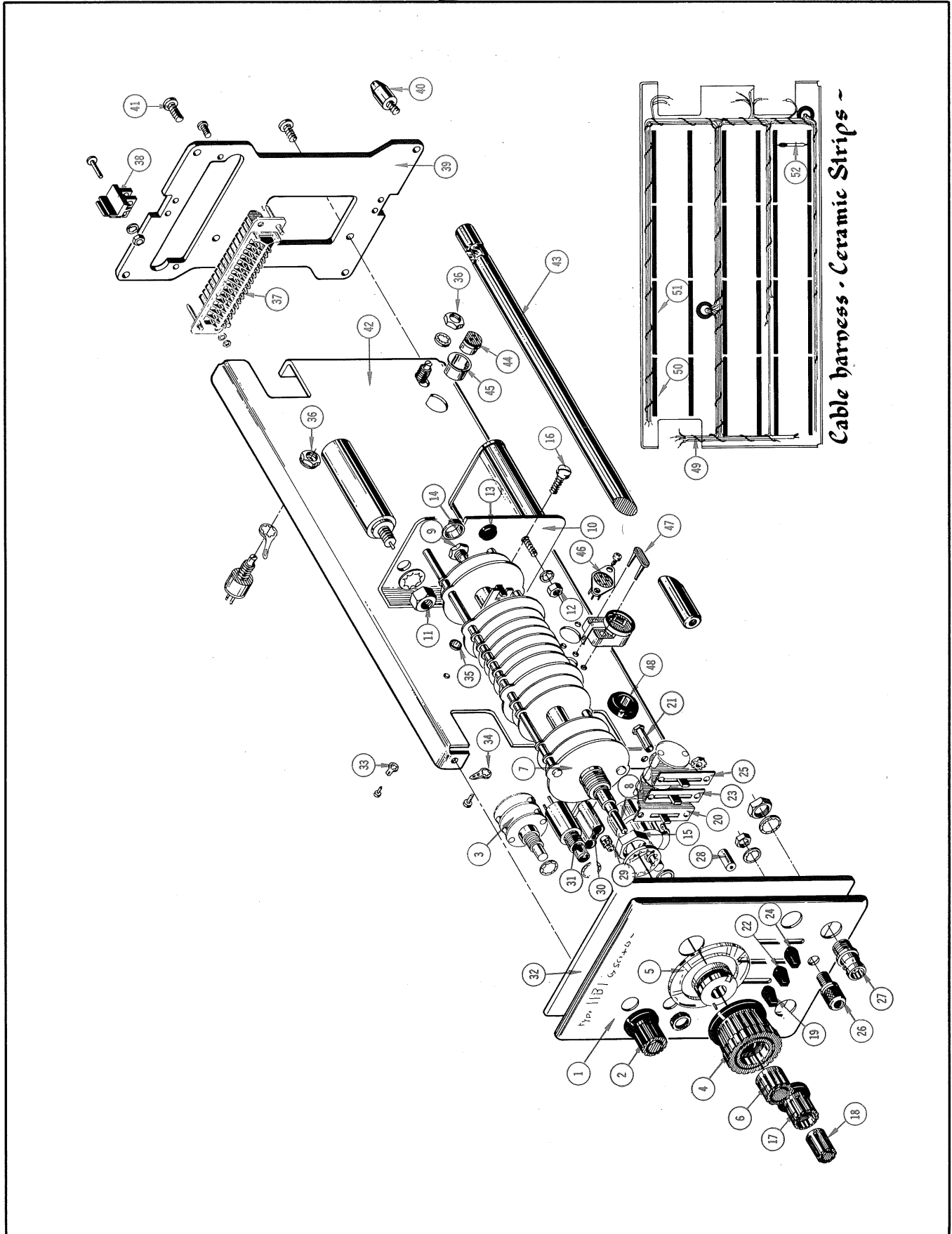

## EXPLODED VIEW

REF. NO.	PART NO.	SERIAL/MODEL NO.		QTY.	DESCRIPTION
		EFF.	DISC.		
1	333-790			1	PANEL, front
2	366-173			1	KNOB, charcoal—TRIGGER MODE
	- - - -			-	Includes:
	213-004			1	SCREW, set 6-32 x $\frac{3}{16}$ inch HSS
3	260-592			1	SWITCH, unwired—TRIGGER MODE
	- - - -			-	Mounting Hardware: (not included)
	210-413			1	NUT, hex, $\frac{3}{8}$ -32 x $\frac{1}{2}$ inch
	210-840			1	WASHER, .390 ID x $\frac{9}{16}$ inch OD
	210-012			1	LOCKWASHER, internal, $\frac{3}{8}$ x $\frac{1}{2}$ inch
4	366-269			1	KNOB, large charcoal—TIME/CM
	- - - -			-	Includes:
	213-022			2	SCREW, set, 4-40 x $\frac{3}{16}$ inch HSS
5	331-132			1	DIAL, window knob
	- - - -			-	Includes:
	213-022			2	SCREW, set, 4-40 x $\frac{3}{16}$ inch HSS
6	366-038			1	KNOB, small red—VARIABLE
	- - - -			-	Includes:
	213-004			1	SCREW, set 6-32 x $\frac{3}{16}$ inch HSS
7	262-635			1	SWITCH, wired—TIME/CM
	- - - -			-	Includes:
	260-593			1	SWITCH, unwired—TIME/CM
8	384-314			1	ROD, extension
	376-014			1	COUPLING, pot
9	- - - -			-	Mounting Hardware For Pot:
	210-413			2	NUT, hex, $\frac{3}{8}$ -32 x $\frac{1}{2}$ inch
	210-012			1	LOCKWASHER, internal, $\frac{3}{8}$ x $\frac{1}{2}$ inch
10	406-992			1	BRACKET, switch
	- - - -			-	Mounting Hardware: (not included)
	210-449			4	NUT, hex, 5-40 x $\frac{1}{4}$ inch
	210-006			2	LOCKWASHER, internal, #6
11	- - - -			-	Mounting Hardware For Each Capacitor:
	210-524			1	NUT, hex, $\frac{5}{16}$ -24 x $\frac{1}{2}$ inch
	210-018			1	LOCKWASHER, $\frac{5}{16}$ inch
12	- - - -			-	Mounting Hardware For Timing Capacitor:
	210-407			2	NUT, hex, 6-32 x $\frac{1}{4}$ inch
	210-006			2	LOCKWASHER, internal, #6
13	348-003			1	GROMMET, $\frac{5}{16}$ inch
14	348-065			1	GROMMET, plastic nylon, split
	- - - -			-	Mounting Hardware For Switch: (not included)
15	210-579			1	NUT, hex, $\frac{5}{8}$ -24 x $\frac{3}{4}$ inch
	210-049			1	LOCKWASHER, internal, $\frac{5}{8}$ inch
16	211-507			2	SCREW, 6-32 x $\frac{5}{16}$ inch BHS
17	366-138			1	KNOB, charcoal—LEVEL
	- - - -			-	Includes:
	213-004			1	SCREW, set, 6-32 x $\frac{3}{16}$ inch HSS
18	366-255			1	KNOB, small red—HF STABILITY
	- - - -			-	Includes:
	213-020			1	SCREW, set, 6-32 x $\frac{1}{8}$ inch HSS
	- - - -			-	Mounting Hardware For Pot:
	210-413			1	NUT, hex, $\frac{3}{8}$ -32 x $\frac{1}{2}$ inch
	210-840			1	WASHER, .390 ID x $\frac{9}{16}$ inch OD
	210-012			1	LOCKWASHER, internal, $\frac{3}{8}$ x $\frac{1}{2}$ inch

EXPLODED VIEW (Cont'd)

REF. NO.	PART NO.	SERIAL/MODEL NO.		QTY.	DESCRIPTION
		EFF.	DISC.		
19	366-0215-00	100	209	1	KNOB, lever—SLOPE
	366-0215-01	210		1	KNOB, lever—SLOPE
20	260-0472-00			1	SWITCH, lever—SLOPE
	- - - - -			-	Mounting Hardware: (not included)
21	220-0413-00			2	NUT, hex, rod, 4-40 x 3/16 x 1/2 inch long
22	366-0215-00	100	209	1	KNOB, lever—COUPLING
	366-0215-01	210		1	KNOB, lever—COUPLING
23	260-0594-00			1	SWITCH, lever—COUPLING
	- - - - -			-	Mounting Hardware: (not included)
	210-0586-00			2	NUT, keps, 4-40 x 1/4 inch
24	366-0215-00	100	209	1	KNOB, lever—SOURCE
	366-0215-01	210		1	KNOB, lever—SOURCE
25	260-0615-00			1	SWITCH, lever—SOURCE
	- - - - -			-	Mounting Hardware: (not included)
	210-0586-00			2	NUT, keps, 4-40 x 1/4 inch
26	129-0035-00			1	POST, ground, assembly
	- - - - -			-	Consisting Of:
	355-0507-00			1	STEM, adapter
	200-0103-00			1	CAP
	210-0455-00			1	NUT, hex, 1/4-28 x 3/8 inch
	210-0046-00			1	LOCKWASHER, internal, .400 OD x .261 inch ID
27	131-0106-00			3	CONNECTOR, chassis mounted, 1 contact, BNC
	- - - - -			-	Each Includes:
	210-0413-00			1	NUT, hex, 3/8-32 x 1/2 inch
	210-0012-00			1	LOCKWASHER, internal, 3/8 x 1/2 inch
28	352-0052-00			1	HOLDER, capacitor
29	378-0541-00			2	FILTER, lens, neon light
30	352-0064-00			1	HOLDER, dual neon
	- - - - -			-	Mounting Hardware: (not included)
	211-0109-00			1	SCREW, 4-40 x 7/8 inch FHS
	210-0406-00			2	NUT, hex, 4-40 x 3/16 inch
31	260-0518-00			1	SWITCH, push, with red indicator light
32	387-0899-00			1	PLATE, front sub-panel
33	210-0259-00			6	LUG, solder, #2
	- - - - -			-	Mounting Hardware For Each: (not included)
	213-0055-00			1	SCREW, thread forming, 2-32 x 3/16 inch PHS
34	210-0201-00			21	LUG, solder, SE #4
	- - - - -			-	Mounting Hardware For Each: (not included)
	213-0044-00			1	SCREW, thread cutting, 5-32 x 3/16 inch PHS
35	348-0055-00			1	GROMMET, plastic, 1/4 inch
36	- - - - -			-	Mounting Hardware For Each Pot:
	210-0583-00			1	NUT, hex, 1/4-32 x 5/16 inch
	210-0940-00			1	WASHER, 1/4 ID x 3/8 inch OD
	210-0223-00			1	LUG, solder, 1/4 inch
37	131-0096-00			1	CONNECTOR, chassis mounted, 32 contact, male
	- - - - -			-	Mounting Hardware: (not included)
	211-0008-00			2	SCREW, 4-40 x 1/4 inch BHS
	210-0004-00			2	LOCKWASHER, internal, #4
	210-0406-00			2	NUT, hex, 4-40 x 3/16 inch
38	351-0063-00			2	GUIDE, shoe, plug-in latch
	- - - - -			-	Mounting Hardware For Each: (not included)
	211-0012-00			2	SCREW, 4-40 x 3/8 inch BHS
	210-0004-00			2	LOCKWASHER, internal, #4
	210-0406-00			2	NUT, hex, 4-40 x 3/16 inch







**ELECTRICAL PARTS LIST**

Values are fixed unless marked Variable.

Ckt. No.	Tektronix Part No.	Description	S/N Range
<b>Bulbs</b>			
B124	150-030	Neon, NE-2V	SWEEP FREE RUN
B180	150-030	Neon, NE-2V	UNCAL
B234†	260-518	Switch w/red Indicator light	READY
B241	150-030	Neon, NE-2V	

**Capacitors**Tolerance  $\pm 20\%$  unless otherwise indicated.

Tolerance of all electrolytic capacitors as follows (with exceptions):

3 V — 50 V =  $-10\%$ ,  $+250\%$ 51 V — 350 V =  $-10\%$ ,  $+100\%$ 351 V — 450 V =  $-10\%$ ,  $+ 50\%$ 

C4	283-080	0.022 $\mu$ f	Cer	25 v	
C5	283-080	0.022 $\mu$ f	Cer	25 v	
C15	281-516	39 pf	Cer	500 v	10%
C21	281-518	47 pf	Cer	500 v	
C23	283-080	0.022 $\mu$ f	Cer	25 v	
C26	283-078	0.001 $\mu$ f	Cer	500 v	
C27	281-542	18 pf	Cer	500 v	10%
C28	281-027	0.7-3 pf	Tub.	Var	
C30A	283-068	0.01 $\mu$ f	Cer	500 v	
C30B	281-523	100 pf	Cer	350 v	
C31	283-068	0.01 $\mu$ f	Cer	500 v	
C32	Use 281-010	4.5-25 pf	Cer	Var	
C37	283-068	0.01 $\mu$ f	Cer	500 v	
C42	283-079	0.01 $\mu$ f	Cer	250 v	
C45	283-079	0.01 $\mu$ f	Cer	250 v	
C47	283-081	0.1 $\mu$ f	Cer	25 v	
C51	290-162	22 $\mu$ f	EMT	35 v	20%
C56	283-080	0.022 $\mu$ f	Cer	25 v	
C58	283-081	0.1 $\mu$ f	Cer	25 v	
C62	283-078	0.001 $\mu$ f	Cer	500 v	
C66	283-080	0.022 $\mu$ f	Cer	25 v	
C82	283-010	0.05 $\mu$ f	Cer	50 v	
C83	281-516	39 pf	Cer	500 v	10%
C88	281-525	470 pf	Cer	500 v	
C93	Use 281-0528-00	82 pf	Cer	500 v	10%

†Furnished as a unit with SW234.

Parts List — Type 11B1

Capacitors (Cont'd)

Ckt. No.	Tektronix Part No.		Description			S/N Range
C102	281-543	270 pf	Cer	500 v	10%	
C104	283-078	0.001 $\mu$ f	Cer	500 v		
C109	283-080	0.022 $\mu$ f	Cer	25 v		
C114	290-189	33 $\mu$ f	EMT	35 v	10%	
C128	281-525	470 pf	Cer	500 v		
C136	281-542	18 pf	Cer	500 v	10%	
C140	281-518	47 pf	Cer	500 v		
C142	283-081	0.1 $\mu$ f	Cer	25 v		
C149	281-516	39 pf	Cer	500 v	10%	
C163	290-139	180 $\mu$ f	EMT	6 v	20%	
C165	281-523	100 pf	Cer	350 v		
C173	281-546	330 pf	Cer	500 v	10%	
C180A	281-010	4.5-25 pf	Cer	Var		
C180B	283-097	84 pf	Cer	1000 v	2%	
C180C	281-010	4.5-25 pf	Cer	Var		
C180D	283-097	84 pf	Cer	1000 v	2%	
C180E	} use *295-0082-00	0.001 $\mu$ f	} Timing Series			
C180F		0.01 $\mu$ f				
C180G		0.1 $\mu$ f				
C180H		1 $\mu$ f				
C180J		10 $\mu$ f				
C180R	281-525	470 pf	Cer	500 v		
C182	283-079	0.01 $\mu$ f	Cer	250 v		
C185	281-509	15 pf	Cer	500 v	10%	
C186	281-523	100 pf	Cer	350 v		
C200A	281-525	470 pf	Cer	500 v		
C200B	281-536	0.001 $\mu$ f	Cer	500 v	10%	
C200C	285-598	0.01 $\mu$ f	PTM	100 v	5%	
C200D	290-188	0.1 $\mu$ f	EMT	20 v		
C200E	290-183	1 $\mu$ f	EMT	35 v	10%	
C200F	290-167	10 $\mu$ f	EMT	15 v	20%	
C212	283-080	0.022 $\mu$ f	Cer	25 v		
C226	281-549	68 pf	Cer	500 v	10%	
C229	281-523	100 pf	Cer	350 v		
C234	285-629	0.047 $\mu$ f	PTM	100 v		
C240	285-622	0.1 $\mu$ f	PTM	100 v		
C241	281-543	270 pf	Cer	500 v	10%	
C242	281-524	150 pf	Cer	500 v		
C246	281-525	470 pf	Cer	500 v		
C247	283-079	0.01 $\mu$ f	Cer	250 v		
C251	290-135	15 $\mu$ f	EMT	20 v	20%	
C270	281-543	270 pf	Cer	500 v	10%	
C302	281-518	47 pf	Cer	500 v		
C326	281-573	11 pf	Cer		10%	100-189
C326	281-509	15 pf	Cer	500 v	10%	190-up
C333	283-081	0.1 $\mu$ f	Cer	25 v		
C343	283-078	0.001 $\mu$ f	Cer	500 v		

## Capacitors (Cont'd)

Ckt. No.	Tektronix Part No.	Description	S/N Range
C346	281-573	11 pf Cer	10% 100-189
C346	281-509	15 pf Cer	10% 190-up
C389	283-078	0.001 $\mu$ f Cer	500 v 100-459X
C406	283-080	0.022 $\mu$ f Cer	25 v
C416	283-080	0.022 $\mu$ f Cer	25 v

## Diodes

D38	*152-045	Silicon	Selected from 1N622A	100-519
D38	152-0246-00	Silicon	Low leakage 0.25 w, 40 v	520-up
D39	*152-045	Silicon	Selected from 1N622A	100-519
D39	152-0246-00	Silicon	Low leakage 0.25 w, 40 v	520-up
D43	Use *152-0185-00	Silicon	Replaceable by 1N3605	
D44	Use *152-0185-00	Silicon	Replaceable by 1N3605	
D46	Use *152-0185-00	Silicon	Replaceable by 1N3605	
D47	152-139	Zener	1N751 .4 w, 5.1 v, 10%	100-729
D47	152-0279-00	Zener	1N751A .4 w, 5.1 v, 5%	730-up
D52	Use *152-0185-00	Silicon	Replaceable by 1N3605	
D54	152-141	Silicon	1N3605	
D55	*152-153	Silicon	Replaceable by 1N4244	
D56	Use *152-0185-00	Silicon	Replaceable by 1N3605	
D64	152-141	Silicon	1N3605	
D65	*152-153	Silicon	Replaceable by 1N4244	
D66	Use *152-0185-00	Silicon	Replaceable by 1N3605	
D80	*152-153	Silicon	Replaceable by 1N4244	
D85	*152-125	Tunnel	Selected TD3A 4.7 MA	
D88	*152-153	Silicon	Replaceable by 1N4244	
D89	*152-153	Silicon	Replaceable by 1N4244	
D102	152-0065-00	Silicon	HD5000	740-up
D102	*152-153	Silicon	Replaceable by 1N4244	100-739
D103	*152-153	Silicon	Replaceable by 1N4244	
D104	152-141	Silicon	1N3605	
D105	*152-125	Tunnel	Selected TD3A 4.7 MA	
D113	Use *152-0185-00	Silicon	Replaceable by 1N3605	
D114	Use *152-0185-00	Silicon	Replaceable by 1N3605	
D122	Use *152-0185-00	Silicon	Replaceable by 1N3605	
D130	*152-153	Silicon	Replaceable by 1N4244	
D131	*152-153	Silicon	Replaceable by 1N4244	
D135	*152-125	Tunnel	Selected TD3A 4.7 MA	
D144	Use *152-0185-00	Silicon	Replaceable by 1N3605	
D163	Use *152-0185-00	Silicon	Replaceable by 1N3605	
D165	Use *152-0185-00	Silicon	Replaceable by 1N3605	
D166	*152-161	GaAs diffused w/axial lead		
D172	Use *152-0185-00	Silicon	Replaceable by 1N3605	
D183	Use *152-0185-00	Silicon	Replaceable by 1N3605	
D200	Use *152-0185-00	Silicon	Replaceable by 1N3605	
D201	Use *152-0185-00	Silicon	Replaceable by 1N3605	
D203	Use *152-0185-00	Silicon	Replaceable by 1N3605	
D213	Use *152-0185-00	Silicon	Replaceable by 1N3605	

**Parts List — Type 11B1**

**Diodes (Cont'd)**

Ckt. No.	Tektronix Part No.	Description	S/N Range
D242	Use *152-0185-00	Silicon	Replaceable by 1N3605
D324	Use *152-0185-00	Silicon	Replaceable by 1N3605
D349	Use *152-0185-00	Silicon	Replaceable by 1N3605
D412	152-123	Zener	T.C. 1N935A .4 w, 9.1 v, 5%

**Inductors**

L4	276-528	Core, Ferramic Suppressor	
L31	*108-287	Reed Drive Single	
L35	*108-287	Reed Drive Single	
L36	*108-287	Reed Drive Single	
L85	*108-112	0.3 $\mu$ h	
L126	*108-147	2.2 $\mu$ h	
L311	276-528	Core, Ferramic Suppressor	
L318	276-528	Core, Ferramic Suppressor	
L338	276-528	Core, Ferramic Suppressor	
L389	276-0507-00	Core, Ferramic Suppressor	X460-up

**Transistors**

Q4	*151-108	Replaceable by 2N2501
Q14	*151-108	Replaceable by 2N2501
Q23	*151-108	Replaceable by 2N2501
Q33	*151-133	Selected from 2N3251
Q54	*151-103	Replaceable by 2N2219
Q64	*151-103	Replaceable by 2N2219
Q73	*151-126	Replaceable by 2N2484
Q84	*151-083	Selected from 2N964
Q94	Use 151-0131-00	2N964
Q114	*151-103	Replaceable by 2N2219
Q124	*151-096	Selected from 2N1893
Q134	*151-108	Replaceable by 2N2501
Q144	*151-108	Replaceable by 2N2501
Q154	*151-108	Replaceable by 2N2501
Q164	151-107	2N967
Q173	151-107	2N967
Q181	*151-127	Selected from 2N2369
Q193	*151-103	Replaceable by 2N2219
Q203	*151-087	Selected from 2N1131
Q215	*151-133	Selected from 2N3251
Q225	*151-133	Selected from 2N3251
Q234	*151-096	Selected from 2N1893
Q244	*151-103	Replaceable by 2N2219
Q303	*151-103	Replaceable by 2N2219
Q313	*151-087	Selected from 2N1131

## Transistors (Cont'd)

Ckt. No.	Tektronix Part No.	Description	S/N Range
Q324	Use *050-224	Replacement Kit	100-189
Q324	*151-133	Selected from 2N3251	190-up
Q333	*151-087	Selected from 2N1131	
Q344	Use *050-224	Replacement Kit	100-189
Q344	*151-133	Selected from 2N3251	190-up
Q353	151-108	Replaceable by 2N2501	
Q363	*151-108	Replaceable by 2N2501	
Q374	*151-108	Replaceable by 2N2501	
Q384	*151-108	Replaceable by 2N2501	

## Resistors

Resistors are fixed, composition,  $\pm 10\%$  unless otherwise indicated.

R	Part No.	Value	Power	Var	Prec	Tolerance	S/N Range
R1	311-326	10 k					
R2	316-392	3.9 k	1/4 w				
R3	315-101	100 $\Omega$	1/4 w			5%	
R4	302-391	390 $\Omega$	1/2 w				
R5	316-330	33 $\Omega$	1/4 w				
R7	323-191	953 $\Omega$	1/2 w		Prec	1%	
R12	315-101	100 $\Omega$	1/4 w			5%	
R14	323-161	464 $\Omega$	1/2 w		Prec	1%	
R15	316-100	10 $\Omega$	1/4 w				
R16	322-094	93.1 $\Omega$	1/4 w		Prec	1%	
R17	323-191	953 $\Omega$	1/2 w		Prec	1%	
R20	303-153	15 k	1 w			5%	
R21	321-225	2.15 k	1/8 w		Prec	1%	
R22	323-313	17.8 k	1/2 w		Prec	1%	
R23	316-471	470 $\Omega$	1/4 w				
R26	315-751	750 $\Omega$	1/4 w			5%	
R27	316-470	47 $\Omega$	1/4 w				
R28	319-037	9 meg	1/4 w		Prec	2%	100-619
R28	325-0021-00	9 meg	1/4 w		Prec	1%	620-up
R29	322-481	1 meg	1/4 w		Prec	1%	
R30	322-385	100 k	1/4 w		Prec	1%	
R31	301-181	180 $\Omega$	1/2 w			5%	
R32	322-470	768 k	1/4 w		Prec	1%	
R33	322-420	232 k	1/4 w		Prec	1%	
R35	301-181	180 $\Omega$	1/2 w			5%	
R36	301-181	180 $\Omega$	1/2 w			5%	
R37	301-105	1 meg	1/2 w			5%	
R38	316-470	47 $\Omega$	1/4 w				
R39	316-470	47 $\Omega$	1/4 w				
R42	316-221	220 $\Omega$	1/4 w				
R43	305-512	5.1 k	2 w			5%	
R44	302-472	4.7 k	1/2 w				
R45	316-104	100 k	1/4 w				

Parts List — Type 11B1

Resistors (Cont'd)

Ckt. No.	Tektronix Part No.		Description		S/N Range
R47	302-472	4.7 k	1/2 w		
R48	316-104	100 k	1/4 w		
R49	303-103	10 k	1 w		5%
R50	321-181	750 Ω	1/8 w	Prec	1%
R51	316-103	10 k	1/4 w		
R52	323-404	158 k	1/2 w	Prec	1%
R53	321-413	196 k	1/8 w	Prec	1%
R54	308-273	6.5 k	5 w	WW	2%
R56	321-161	464 Ω	1/8 w	Prec	1%
R58	316-330	33 Ω	1/4 w		
R62	316-220	22 Ω	1/4 w		
R66	321-161	464 Ω	1/8 w	Prec	1%
R73	301-683	68 k	1/2 w		5%
R74	316-101	100 Ω	1/4 w		
R75	315-272	2.7 k	1/4 w		5%
R76	315-822	8.2 k	1/4 w		5%
R77	316-102	1 k	1/4 w		
R78†	311-272	5 k		Var	LEVEL
R79	316-681	680 Ω	1/4 w		
R80	323-332	28 k	1/2 w	Prec	1%
R81	321-224	2.1 k	1/8 w	Prec	1%
R82	321-153	383 Ω	1/8 w	Prec	1%
R83	316-220	22 Ω	1/4 w		
R84	323-321	21.5 k	1/2 w	Prec	1%
R85	315-750	75 Ω	1/4 w		5%
R88	315-222	2.2 k	1/4 w		5%
R89	321-245	3.48 k	1/8 w	Prec	1%
R91	Use 316-0470-00	47 Ω	1/4 w		
R93	301-223	22 k	1/2 w		5%
R94	315-242	2.4 k	1/4 w		5%
R104	316-471	470 Ω	1/4 w		
R105	315-112	1.1 k	1/4 w		5%
R106	323-281	8.25 k	1/2 w	Prec	1%
R109	316-330	33 Ω	1/4 w		
R110	321-105	121 Ω	1/8 w	Prec	1%
R111	321-303	14 k	1/8 w	Prec	1%
R112	321-229	2.37 k	1/8 w	Prec	1%
R113	321-271	6.49 k	1/8 w	Prec	1%
R114	315-471	470 Ω	1/4 w		5%
R116	321-250	3.92 k	1/8 w	Prec	1%
R122	316-392	3.9 k	1/4 w		
R123	321-258	4.75 k	1/8 w	Prec	1%
R124	316-224	220 k	1/4 w		
R125	316-473	47 k	1/4 w		
R126	316-331	330 Ω	1/4 w		

†Furnished as a unit with R201.

Resistors (Cont'd)

Ckt. No.	Tektronix Part No.		Description			S/N Range
R128	315-101	100 Ω	1/4 w			5%
R129	321-243	3.32 k	1/8 w		Prec	1%
R130	321-258	4.75 k	1/8 w		Prec	1%
R134	315-112	1.1 k	1/4 w			5%
R136	315-112	1.1 k	1/4 w			5%
R140	321-250	3.92 k	1/8 w		Prec	1%
R141	322-341	34.8 k	1/4 w		Prec	1%
R142	316-101	100 Ω	1/4 w			
R143	323-171	590 Ω	1/2 w		Prec	1%
R144	315-162	1.6 k	1/4 w			5%
R145	321-173	619 Ω	1/8 w		Prec	1%
R149	316-472	4.7 k	1/4 w			
R154	315-122	1.2 k	1/4 w			5%
R156	315-621	620 Ω	1/4 w			5%
R162	323-184	806 Ω	1/2 w		Prec	1%
R163	Use 321-121	178 Ω	1/8 w		Prec	1%
R164	315-512	5.1 k	1/4 w			5%
R165	316-101	100 Ω	1/4 w			
R171	315-392	3.9 k	1/4 w			5%
R172	316-473	47 k	1/4 w			
R173	316-101	100 Ω	1/4 w			
R179A† } R179B† }	311-439	20 k 500 Ω		Var	VARIABLE	(Time/CM) (EXT HORIZ INPUT)
R180A	323-654	75 k	1/2 w		Prec	1/2 %
R180B	323-654	75 k	1/2 w		Prec	1/2 %
R180C	315-392	3.9 k	1/4 w			5%
R180D	323-653	221 k	1/2 w		Prec	1/4 %
R180E	323-657	750 k	1/2 w		Prec	.1%
R180F	323-655	750 k	1/2 w		Prec	1/2 %
R180G	323-655	750 k	1/2 w		Prec	1/2 %
R180H	323-656	1.5 meg	1/2 w		Prec	1/2 %
R180J	309-440	3.74 meg	1/2 w		Prec	1%
R180K	309-441	7.5 meg	1/2 w		Prec	1%
R180R	316-470	47 Ω	1/4 w			
R180T	316-182	1.8 k	1/4 w			
R180W	311-328	1 k		Var		SWP CAL
R180X	316-184	180 k	1/4 w			
R181	316-470	47 Ω	1/4 w			
R182	316-221	220 Ω	1/4 w			
R183	316-471	470 Ω	1/4 w			
R184	323-315	18.7 k	1/2 w		Prec	1%
R185	316-220	22 Ω	1/4 w			
R186	316-101	100 Ω	1/4 w			
R187	316-220	22 Ω	1/4 w			

†Furnished as a unit with SW179.

Parts List — Type 11B1

Resistors (Cont'd)

Ckt. No.	Tektronix Part No.		Description		S/N Range
R189	305-752	7.5 k	2 w		5%
R193	315-751	750 $\Omega$	1/4 w		5%
R194	315-333	33 k	1/4 w		5%
R200	315-124	120 k	1/4 w		5%
R201†	311-272	5 k		Var	HF STABILITY
R202	315-153	15 k	1/4 w		5%
R203	316-393	39 k	1/4 w		
R211	321-207	1.4 k	1/8 w	Prec	1%
R212	321-255	4.42 k	1/8 w	Prec	1%
R215	321-171	590 $\Omega$	1/8 w	Prec	1%
R216	321-189	909 $\Omega$	1/8 w	Prec	1%
R225	324-305	14.7 k	1 w	Prec	1%
R226	316-101	100 $\Omega$	1/4 w		
R227	316-221	220 $\Omega$	1/4 w		
R228	315-113	11 k	1/4 w		5%
R229	321-225	2.15 k	1/8 w	Prec	1%
R231	321-225	2.15 k	1/8 w	Prec	1%
R232	322-357	51.1 k	1/4 w	Prec	1%
R234	316-225	2.2 meg	1/4 w		
R235	316-473	47 k	1/4 w		
R236	316-473	47 k	1/4 w		
R238	316-564	560 k	1/4 w		
R239	316-333	33 k	1/4 w		
R241	316-104	100 k	1/4 w		
R243	316-473	47 k	1/4 w		
R244	316-223	22 k	1/4 w		
R245	316-104	100 k	1/4 w		
R246	316-473	47 k	1/4 w		
R247	316-103	10 k	1/4 w		
R249	316-104	100 k	1/4 w		
R251	316-330	33 $\Omega$	1/4 w		
R302	315-331	330 $\Omega$	1/4 w		5%
R303	301-512	5.1 k	1/2 w		5%
R304	311-097	200 $\Omega$	1/2 w	Var	EXT HORIZ GAIN
R307	311-095	500 $\Omega$		Var	EXT HORIZ BAL
R308	316-471	470 $\Omega$	1/4 w		
R309	315-511	510 $\Omega$	1/4 w		5%
R311	316-275	2.7 meg	1/4 w		
R313	301-563	56 k	1/2 w		5%
R321	324-317	19.6 k	1 w		1%
R322	311-328	1 k		Var	MAG REGIS
R324	315-753	75 k	1/4 w		5%
R326	316-101	100 $\Omega$	1/4 w		

†Furnished as a unit with R78.



## Resistors (Cont'd)

Ckt. No.	Tektronix Part No.		Description		S/N Range
R330	315-473	47 k	1/4 w		5%
R331	315-821	820 $\Omega$	1/4 w		5%
R332	315-682	6.8 k	1/4 w		5%
R333	301-334	330 k	1/2 w		5%
R334	301-563	56 k	1/2 w		5%
R340A	325-002	2.67 k	1/8 w	Prec	.1%
R340B	322-653	1.335 k	1/4 w	Prec	1/2 %
R340C	322-652	1.068 k	1/4 w	Prec	1/2 %
R340D	322-651	661 $\Omega$	1/4 w	Prec	1/2 %
R340E	322-650	533 $\Omega$	1/4 w	Prec	1/2 %
R340F	322-649	266 $\Omega$	1/4 w	Prec	1/2 %
R340G	322-648	133 $\Omega$	1/4 w	Prec	1/2 %
R340H	322-647	106 $\Omega$	1/4 w	Prec	1/2 %
R340J	322-646	66 $\Omega$	1/4 w	Prec	1/2 %
R340K	322-645	52.5 $\Omega$	1/4 w	Prec	1/2 %
R341	324-317	19.6 k	1 w	Prec	1%
R343	321-181	750 $\Omega$	1/8 w	Prec	1%
R344	315-753	75 k	1/4 w		5%
R346	316-101	100 $\Omega$	1/4 w		
R353	324-285	9.09 k	1 w	Prec	1%
R355	321-319	20.5 k	1/8 w	Prec	1%
R363	324-285	9.09 k	1 w	Prec	1%
R365	321-319	20.5 k	1/8 w	Prec	1%
R371	321-097	100 $\Omega$	1/8 w	Prec	1%
R374	323-373	75 k	1/2 w	Prec	1%
R375	321-289	10 k	1/8 w	Prec	1%
R381	321-097	100 $\Omega$	1/8 w	Prec	1%
R384	323-373	75 k	1/2 w	Prec	1%
R385	321-289	10 k	1/8 w	Prec	1%
R388	315-102	1 k	1/4 w		5%
R389	315-473	47 k	1/4 w		5%
R401	321-239	3.01 k	1/8 w	Prec	1%
R402	316-822	8.2 k	1/4 w		
R403	321-273	6.81 k	1/8 w	Prec	1%
R405	303-200	20 $\Omega$	1 w		5%
R412	305-332	3.3 k	2 w		5%
R415	316-472	4.7 k	1/4 w		
R416	316-472	4.7 k	1/4 w		

## Switches

	Unwired	Wired	
SW29	260-615	Lever	SOURCE
SW30	260-594	Lever	COUPLING
SW31	260-552	Reed	
SW32	260-592	Rotary	TRIGGER MODE
SW35	260-552	Reed	

**Parts List — Type 11B1**

**Switches (Cont'd)**

Ckt. No.	Tektronix Part No.	Description	S/N Range
SW36	260-552	Reed	
SW50	260-472	Lever	SLOPE
SW179†	311-439		CALIB
SW180	260-593 *262-635	Rotary	TIME/CM
SW234††	260-518	w/red Indicator Light	PUSH TO RESET

**Electron Tubes**

V43	Use *154-0306-02	7586, aged
V183	Use *154-0306-02	7586, aged

†Furnished as a unit with R179A and R179B.

††Furnished as a unit with B234.

## GRAPHIC CALIBRATION PROCEDURE FOR 11B1

The following calibration procedure is a step-by-step graphic calibration training device. Two procedures are included for the 11B1. One is a complete calibration including all adjustments and checks to insure that the instrument meets or exceeds all catalog specifications. The second procedure is a short form version containing only the information necessary to adjust the five internal calibration controls without test equipment. Adjustment of the two variable timing capacitors which establish the accuracy of the six fastest sweep rates of the sweep generator is not described in the short form version because a timing standard other than the 1 kc CALIBRATOR would be required.

EQUIPMENT REQUIRED

1. Type 647 Tektronix oscilloscope (calibrated).
2. Type 10 series vertical plug-in such as the 10A2 (need not be calibrated, but must operate in all respects).
3. Type 180A time-mark generator.
4. Type 190A or B constant amplitude sine-wave generator.
5. Test oscilloscope.
6. UHF-BNC adapter (103-032) for connecting type 180A-190B to the BNC connector on the 11B1.
7. Adjustment tool (screwdriver).
8. X10 probe (P6008 or equivalent).
9. 50 $\Omega$  terminator: 011-045 (UHF) 011-049 (BNC).
10. BNC T adapter (103-030).
11. Several BNC 50 $\Omega$  coaxial cables.

OUTLINE OF ADJUSTMENTS

I. TRIGGERING ADJUSTMENTS

- A. INT TRIG DC LEVEL (R1)
- B. LINE TRIGGERING CHECK
- C. SINGLE SWEEP CHECK
- D. LOW FREQUENCY CHECKS
- E. INTERNAL HIGH FREQUENCY TRIGGERING CHECK
- F. EXTERNAL HIGH FREQUENCY TRIGGERING CHECK

II. TIMING ADJUSTMENTS AND CHECKS

- A.

Remove the cover from the right hand side of the 647 oscilloscope and apply power to the instrument.

Preset the 11B1 front panel controls as follows:

TIME/CM	EXT INPUT
HORIZONTAL VOLTS/CM	.1 VOLT/CM
TRIGGER MODE	AUTO BASE LINE--MANUAL LEVEL
VARIABLE TIME/CM	Calibrated
TRIGGERING	
LEVEL	0
HF STABILITY	Midrange
SLOPE	+
COUPLING	AC
SOURCE	INT

Preset the vertical plug-in (10A2) front panel controls as follows:

VOLTS/CM	.5
VARIABLE	CALIB
AC-DC-GND	AC
VERTICAL POSITION	Centered

(Dual Trace Plug-In)

MODE	CH 1
TRIGGER	NORM
PULL TO INVERT	Pushed in

Preset 647 front panel controls as follows:

CALIBRATOR	2 volts
HORIZ POSITION	Centered
INTENSITY	Adjusted to obtain a spot on the CRT.
FOCUS	Adjusted to obtain a sharp, fine
ASTIGMATISM	spot.

Figure 1 illustrates all the controls in their preset position.

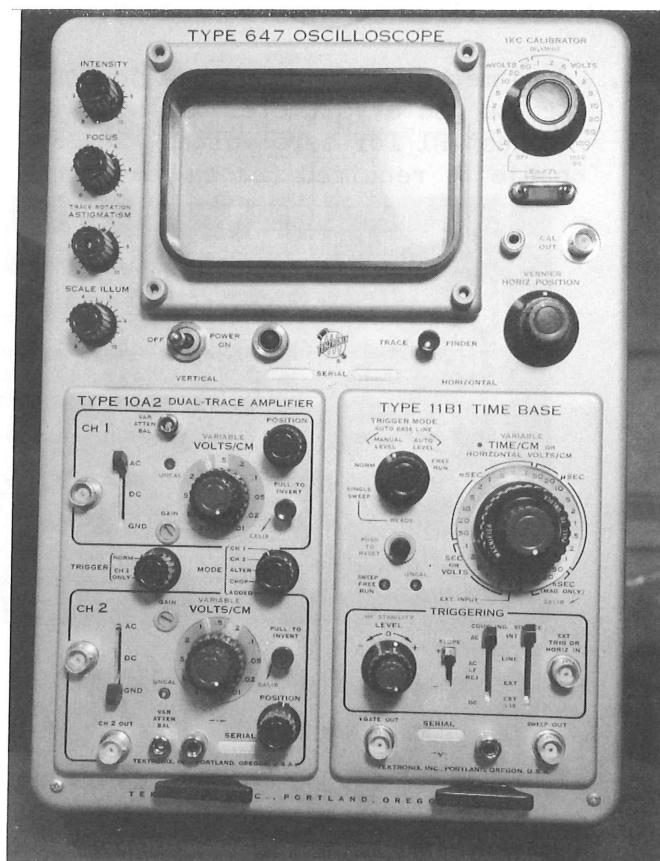

Figure 1

I. TRIGGERING ADJUSTMENTS AND CHECKS

A. INT TRIG DC LEVEL (R1)

1. INT TRIG DC LEVEL (R1)

The purpose of R1 is to be able to adjust for zero volts at the output of TRIGGER PREAMP (Emitter of Q33) with zero volts at pins 13 and 15.

- a. Two methods are available for this adjustment. One is to use a voltmeter and with the 10A2 pulled, adjust R1 for zero volts. See Fig. 2. An extension cable is required for this method.

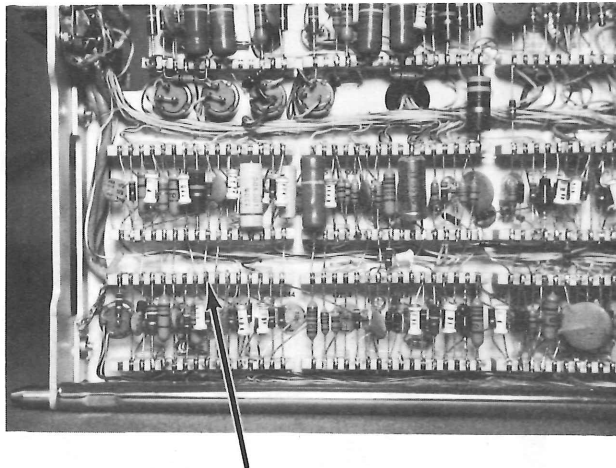

Emitter of Q33 (TP 33)

Figure 2

- b. Method two uses the EXT HORIZ preamp as the indicator.

- (1) Partially remove the 10A2 plug-in (pulled out sufficiently to disconnect the blue ribbon connector).
- (2) With the front panel controls preset to the original setup, adjust INT TRIG DC LEVEL control (R1 - see Fig. 3A) so the spot on the CRT remains stationary (no horizontal movement) while moving the TRIGGERING COUPLING switch between the AC and DC positions. See Fig. 3B.
- (3) Reset COUPLING switch to AC position.
- (4) Reinstall vertical plug-in unit.



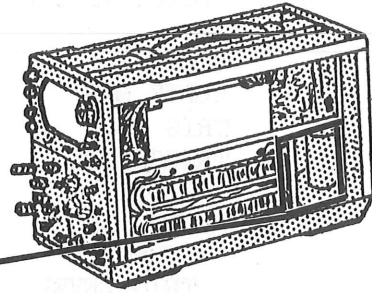
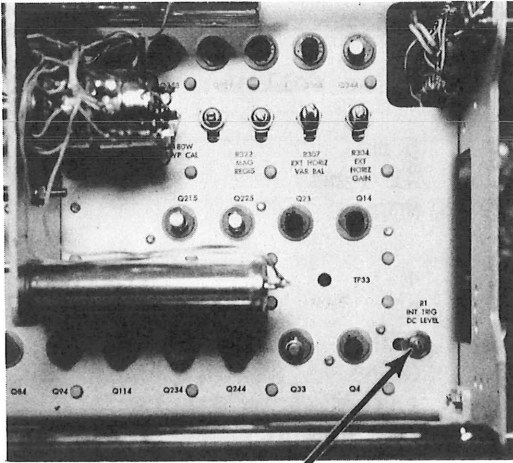

R1 INT TRIG  
DC LEVEL

Figure 3A

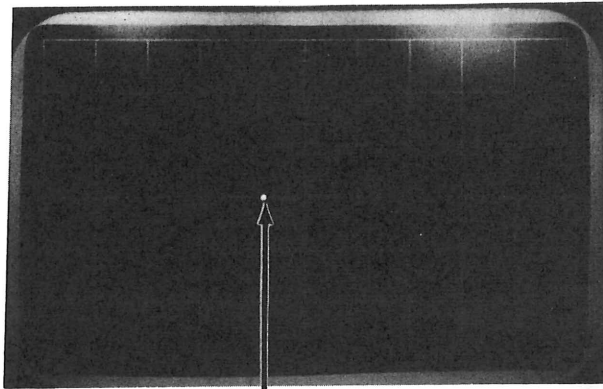

With 10A2 pulled, no horizontal movement  
of dot while moving COUPLING switch  
between AC and DC.

Figure 3B

B. LINE TRIGGERING CHECK

1. Preset 11B1 front panel controls as follows:

TIME/CM	5 ms
HORIZ MAG	X1 (5ms)
TRIG MODE	NORM
TRIGGERING	
SLOPE	+
COUPLING	AC
SOURCE	LINE
TRIG LEVEL	0
10A2 volts/cm	Adjusted to display $\approx$ 4 cm of signal.

2. Connect an X10 probe between the vertical input and a source of a power line frequency sine wave signal (source of 60 cps could be the graticule lights). See Fig.4. Adjust vertical volts/cm control to produce approximately 4 cm of display.

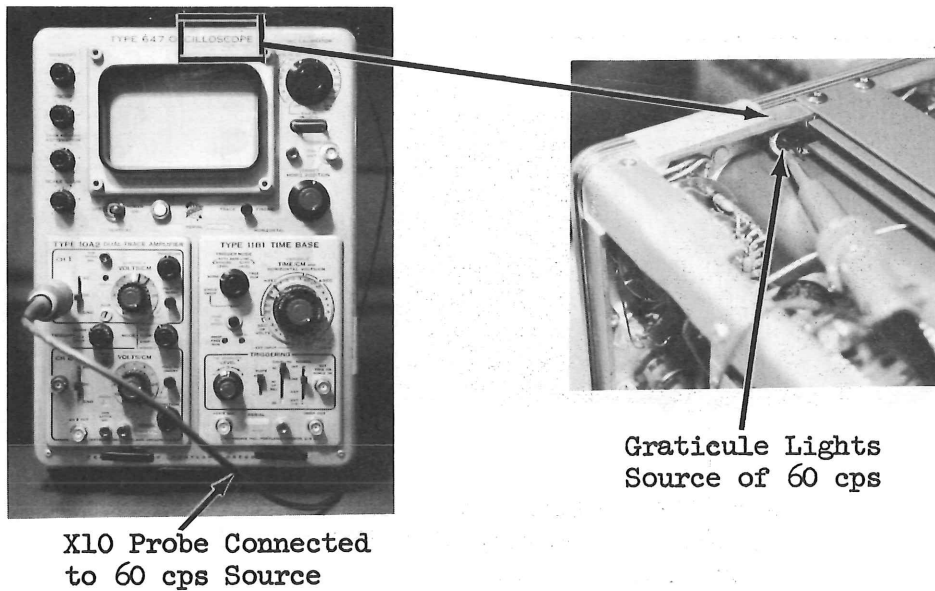
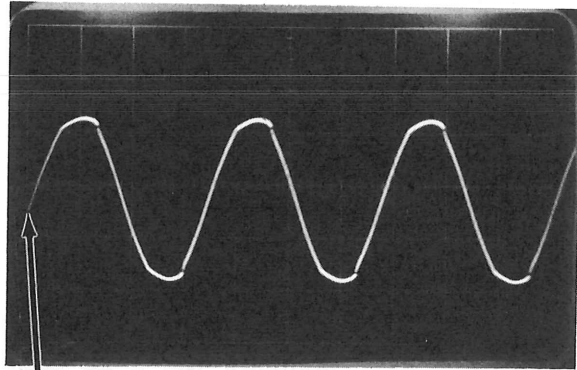
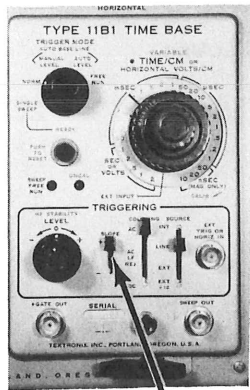

Figure 4

3. Check that a triggered display can be obtained by adjusting the LEVEL control and with SLOPE switch in + position, that the signal starts on the rising portion of the sine wave. See Fig.5.



With SLOPE switch in + 60 cps waveform starts on rising portion.

Figure 5

4. Set SLOPE switch to - position. The display should begin with the negative portion of the sine wave. See Fig. 6.

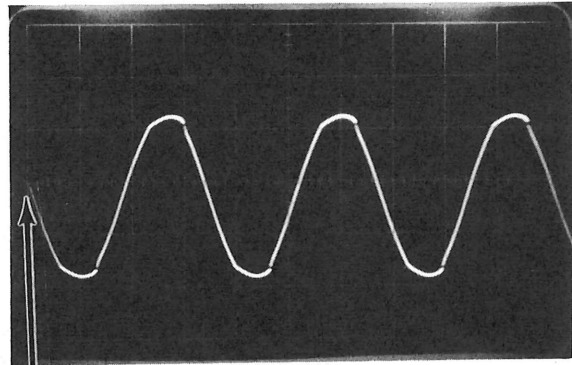
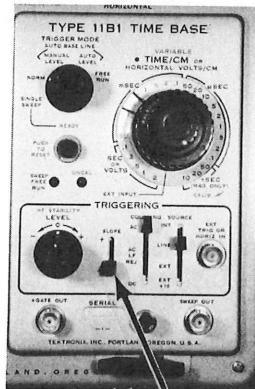

With SLOPE switch in - 60 cps waveform starts on falling portion.

Figure 6

5. Disconnect the probe.

C. SINGLE SWEEP CHECK

1. Preset 11B1 controls as follows:

TIME/CM	1 ms
TRIGGER MODE	AUTO
TRIGGERING	
SLOPE	+
COUPLING	AC
SOURCE	INT
TRIG LEVEL	0

2. Connect the 1 kc calibrator output to the vertical input and display approximately 4 cm triggered display. See Fig. 7.

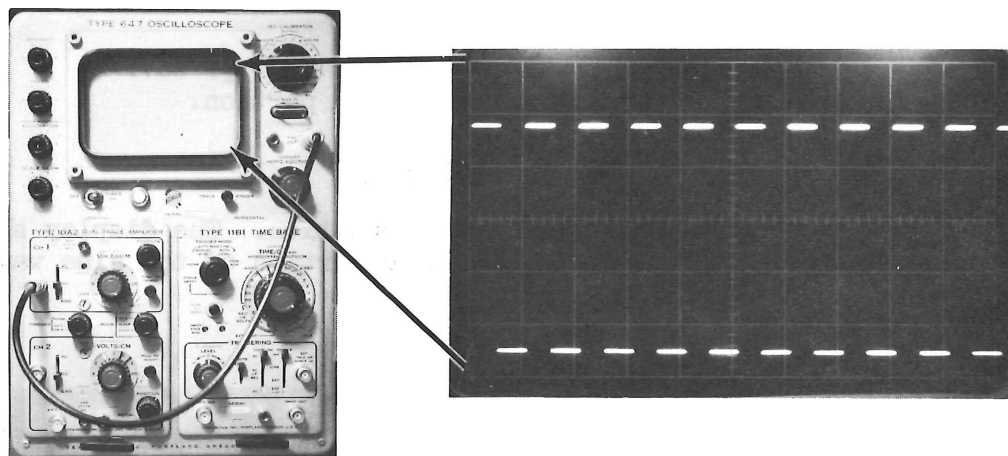
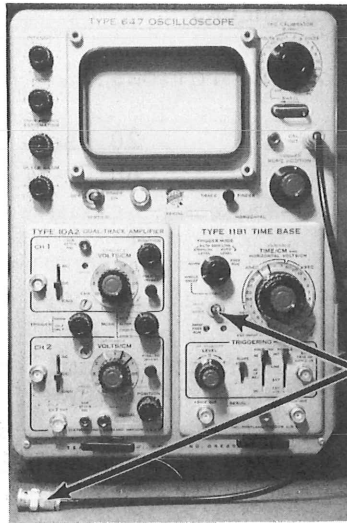

Figure 7

3. Set the TRIGGER MODE switch to SINGLE SWEEP position. The displayed signal on the CRT should disappear.
4. Press the RESET button. Each time the RESET button is pressed a trace should appear on the CRT.
5. Remove the signal from the vertical input connector.
6. Press the RESET button. The RESET lamp should light. See Fig. 8.



With signal disconnected, press the RESET button. The RESET lamp should light.

Figure 8

7. Apply the signal again to the vertical input connector.
8. Observe a single trace on the CRT.
9. Remove the 1 kc CALIBRATOR signal from the vertical input and set the 1 kc CALIBRATOR to 5 volt position.
10. Momentarily connect the CALIBRATOR output to pin F of J101 on the rear panel of the 647. See Fig. 9.
11. The RESET lamp should light.
12. Now, if you apply a signal to the vertical input connector, a single sweep should be observed on the CRT.

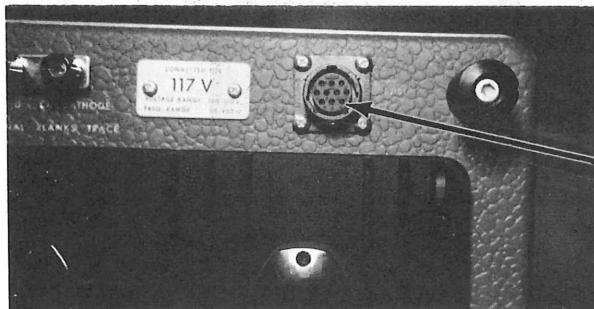

Pin F. 5 volt SIGNAL with  $T_r \leq \mu\text{sec}$  will reset the single sweep circuit.

Figure 9

D. LOW FREQUENCY TRIGGERING CHECKS

1. Preset 11B1 controls as follows:

TIME/CM	20 $\mu$ sec
TRIG MODE	AUTO
TRIGGERING	
SLOPE	+
COUPLING	AC
SOURCE	INT

2. Connect the 190 A or B constant amplitude sine wave generator to the vertical input. Terminate the generator with a  $50\Omega$  terminator, and use a UHF to BNC adapter (190B with new ATTEN does not require an extra  $50\Omega$  terminator). For the next few steps a BNC T adapter is required and this can also be installed at this time. See Figure 10A.
3. Set the 190 A or B for a 125 millivolt peak-to-peak output at 50 kc. See Figure 10A.
4. Set the vertical volts/cm to .5 volts/cm.
5. Adjust TRIGGER LEVEL control for a stable display. 2 mm of vertical deflection should be displayed on the CRT. See Figure 10B.

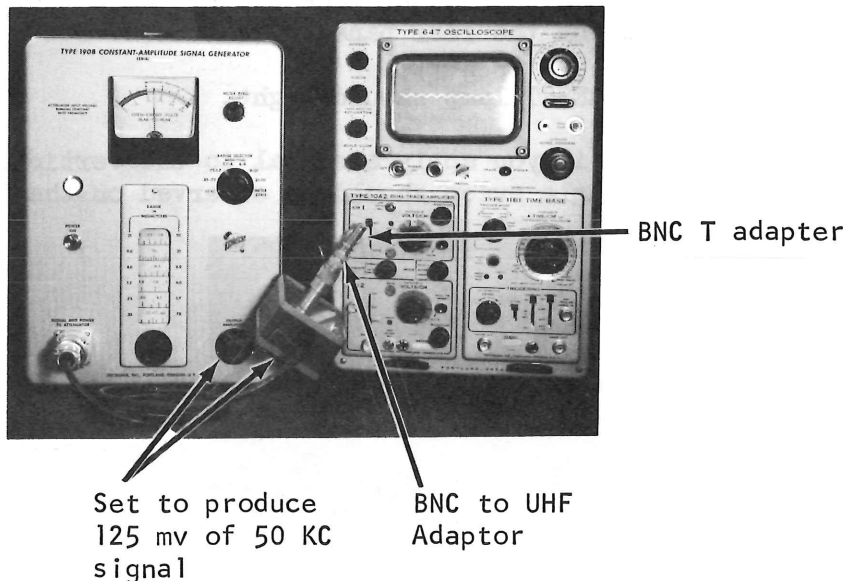

Figure 10A

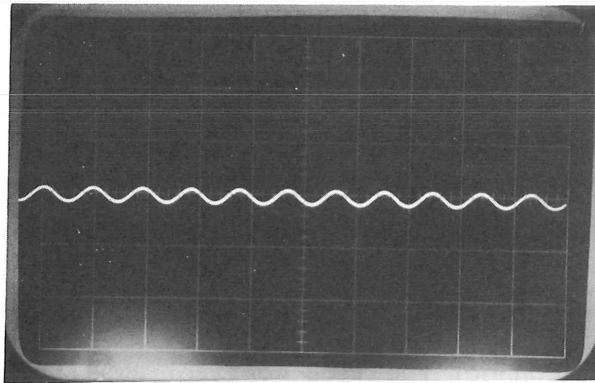

Figure 10B

6. Check that a stable sine wave display can be obtained by setting the SLOPE control to either + or - position. (Slight adjustment of TRIGGER LEVEL control may be necessary.)
7. Check that a stable sine wave display can be obtained by setting the COUPLING control to AC, AC LF REJ and DC position. (May have to adjust vertical position or TRIG LEVEL control to obtain a display with COUPLING switch.)
8. Connect a BNC cable from the BNC T adapter to the EXT TRIG or HORIZ IN connector. See Fig. 11.

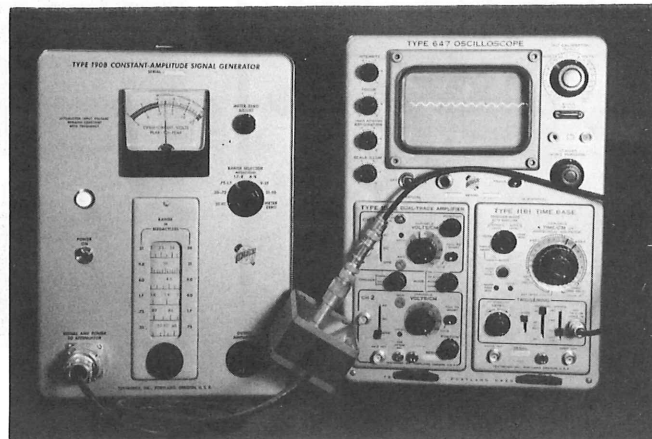

Figure 11

9. EXT TRIG CHECK: Set the SOURCE control to EXT position (not EXT  $\div$  10 position) and check that a stable display can be obtained by adjusting the TRIGGER LEVEL control. At 50 kc you should be able to EXT trigger with 125 millivolts of signal.

10. Return SOURCE control to INT position.

E. INTERNAL HIGH FREQUENCY TRIGGERING CHECK

1. Preset 11B1 front panel controls as follows:

TIME/CM	.1 $\mu$ sec
TRIG MODE	NORM
TRIGGERING	
COUPLING	AC
SOURCE	INT
SLOPE	+

2. Connect the 190B constant amplitude sine wave generator to the vertical input using a UHF to BNC adapter. See Figure 12.

3. Set the 190B to 50 mc sine wave.

4. Adjust either the vertical volts/cm or 190 ATTEN or both to produce a 1 cm display.

5. Adjust LEVEL control for a stable display (may have to adjust HF stability control). See Figure 12.

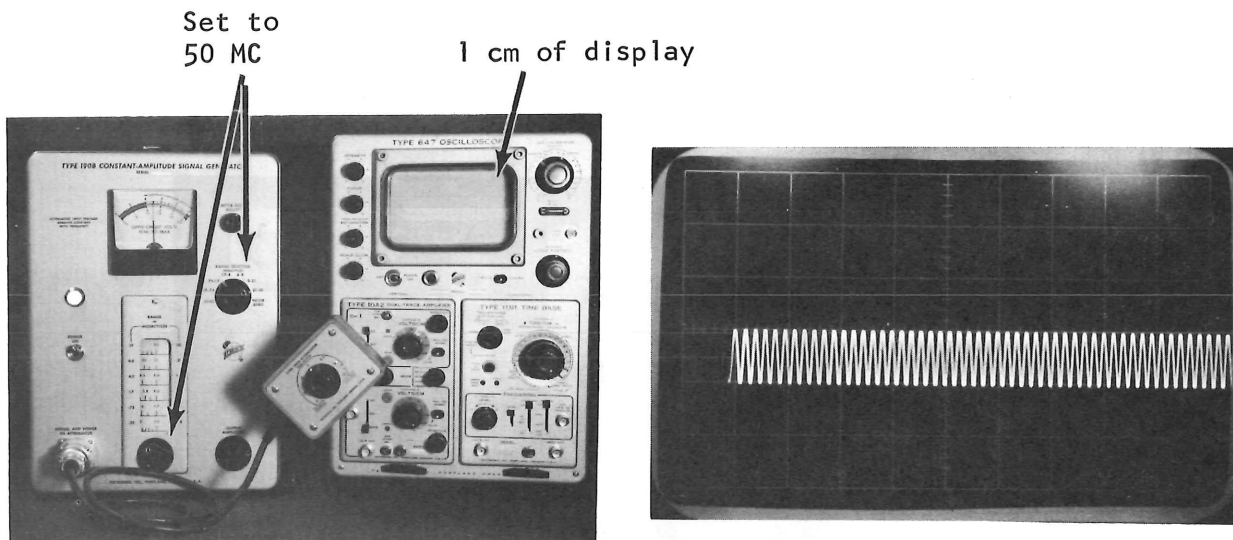

Figure 12



6. Stable triggering should be obtained when setting the SLOPE switch to + or -. (Slight adjustment of LEVEL control may be necessary.)
7. Stable triggering should also be obtained when setting the COUPLING control to AC LF REJ and DC positions.

F. EXTERNAL HIGH FREQUENCY TRIGGERING CHECK

1. Preset 11B1 front panel controls as follows:

TIME/CM	.1 msec
TRIG MODE	NORM
TRIGGERING	
COUPLING	AC
SOURCE	INT
SLOPE	+

2. Connect the 190B constant amplitude sine wave generator to the EXT TRIG in connector using a UHF to BNC adapter. See Figure 13.

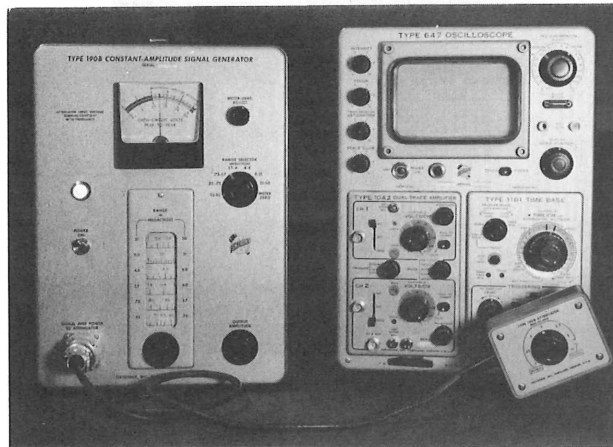

Figure 13

3. Connect a P6008 probe between the vertical input and the terminal on the rear of the EXT TRIG IN connector. Connect the probe-body ground lead to the Type 11B1. See Fig. 14A.
4. Set the vertical volts/cm control to .01.
5. Adjust 190 output amplitude control and ATTEN head to display 250 millivolts of signal at 50 kc (2.5 cm). See Fig. 14B.

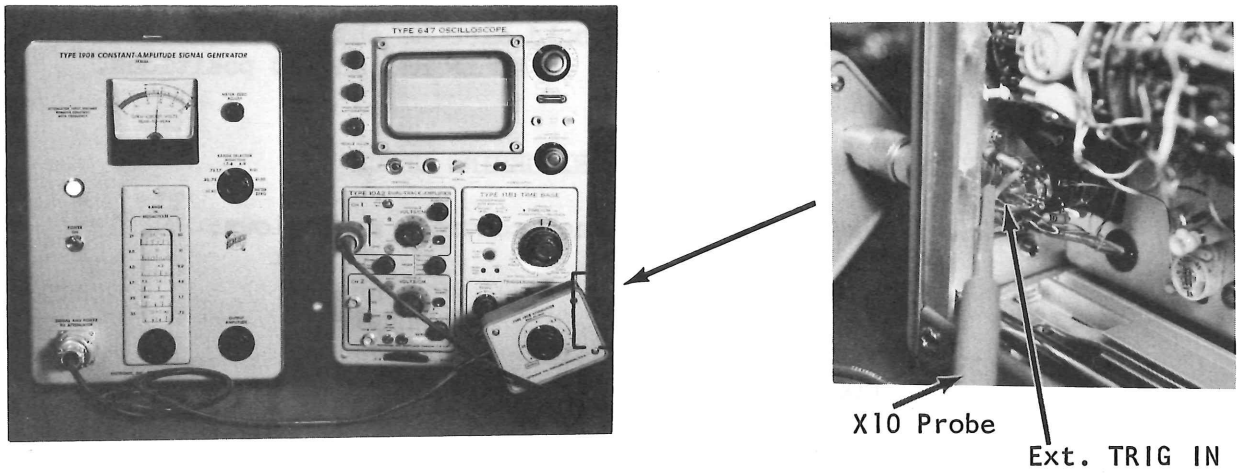
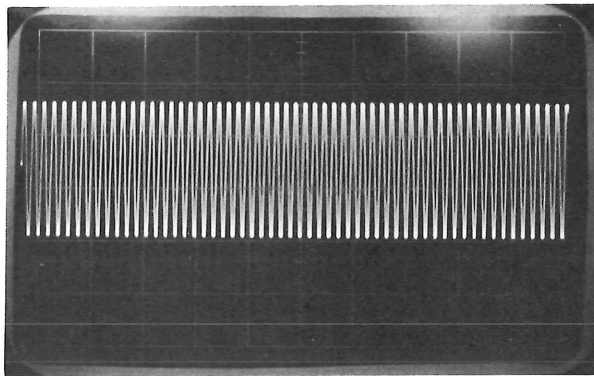

Figure 14A



2.5 cm      250 mv at  
50 KC

Figure 14B

6. Set the 190 output frequency to 50 mc and the TIME/CM control to  $.1 \mu\text{s}/\text{cm}$  position.
7. Set the SOURCE switch to EXT position (not EXT  $\div$  10 position).
8. Check that a stable sine wave display can be obtained by adjusting LEVEL and HF STABILITY controls. See Figure 15. At 50 mc you should be able to EXT trigger with 250 mv of signal.

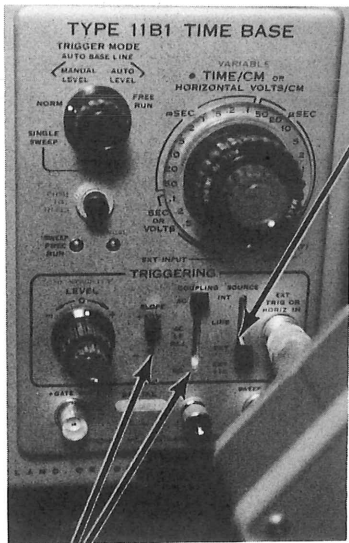

SOURCE switch  
to EXT  
position

Stable  
Triggering  
at 50 MC  
with 250 mv

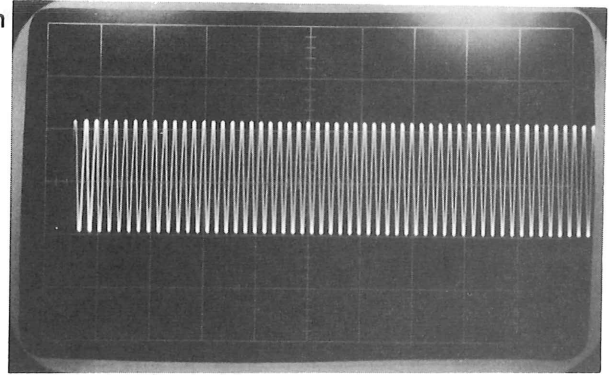

Stable triggering + or -  
also in AC-AC LF REJ-DC

Figure 15

9. Stable triggering should be obtained with SLOPE switch in + or - position and when the COUPLING control is in AC LF REJ or DC positions. (Slight adjustment of LEVEL control may be necessary to obtain stable triggering.)
10. Return SOURCE switch to INT and COUPLING to AC.
11. Disconnect the 190B sine-wave generator and remove P6008 probe.

## II. TIMING ADJUSTMENTS and CHECKS

### A. SWEEP CAL Adjustment

1. Preset the following 11B1 front panel controls:

TIME/CM	1 msec
MAGNIFIER	X1 (1 msec)
TRIGGER MODE	NORM
TRIGGERING	
SLOPE	+
COUPLING	AC
SOURCE	INT.
LEVEL	0

See Figure 16.

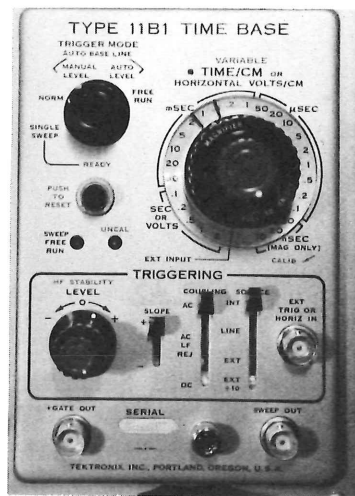

Figure 16

2. Apply to CH 1 input connector, 1 msec timing marks from the type 180A time mark generator.
3. Set the CH 1 VOLTS/CM control to display approximately 3 cm of signal.

4. Adjust the 11B1 LEVEL control for a triggered display. See Figure 17.

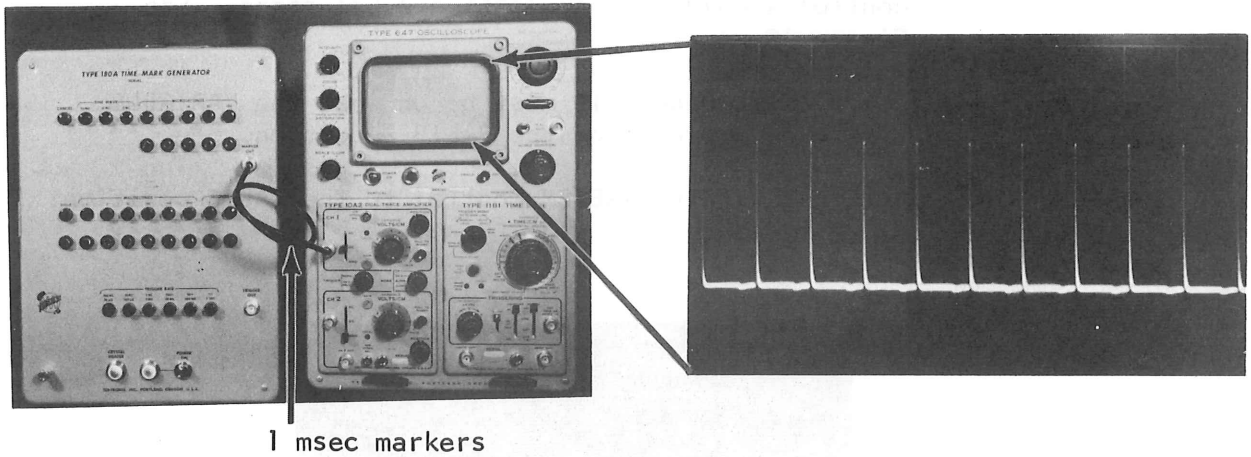
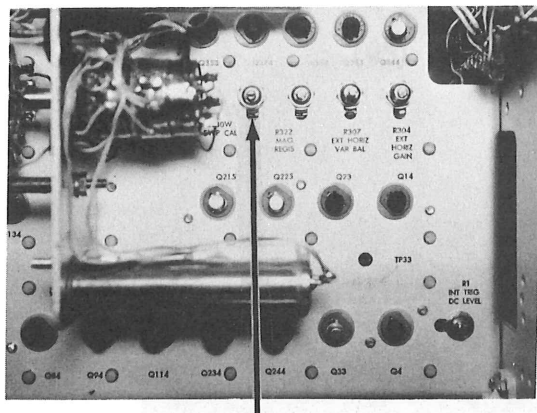

Figure 17

5. Adjust SWP CAL (R180W - see Figure 18A) adjustment to display 1 pulse/cm as viewed on the middle eight centimeters. See Figure 18B.



R180W SWP CAL

(A)

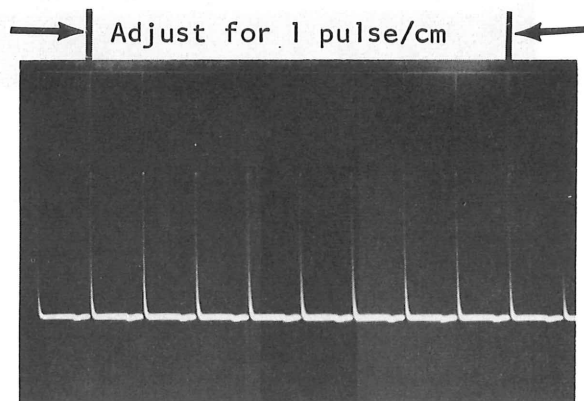
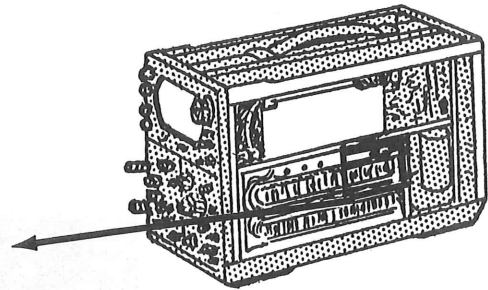

(B)

Figure 18

B. VARIABLE TIME/CM Check

1. Using the same set-up as in step A, rotate the VARIABLE TIME/CM control through its range. The control should have at least a 2.5:1 range. See Figure 19.
2. Check UNCAL neon. It must be on when the VARIABLE control is moved from the CALIB. position.
3. Return VARIABLE TIME/CM control to the CALIB position.

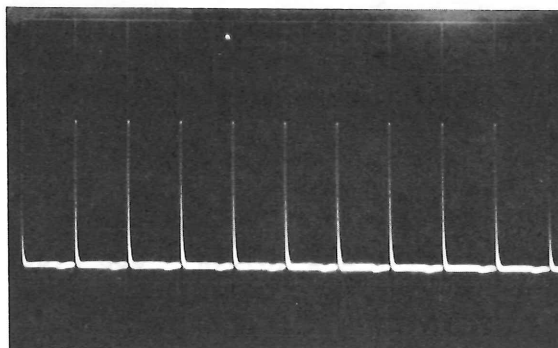

1 pulse/cm  
CALIB. position (CW)

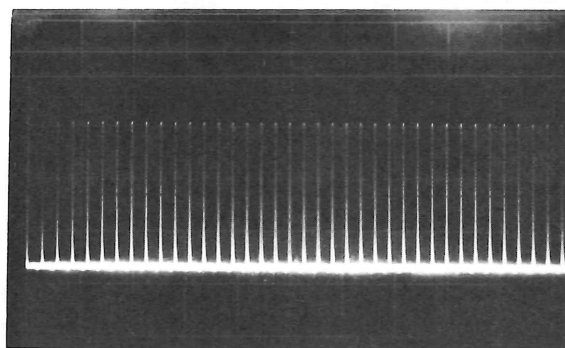

At least 2.5 pulses/cm with  
VARIABLE TIME/CM control CCW  
UNCAL POSITION (CCW)

Figure 19

### C. SWEEP Length Check

1. While displaying 1 msec markers (TIME/CM set to 1 msec), position the display to the left of the CRT screen and check that the sweeps terminates between 10.5 - 11.0 cm. See Figure 20.

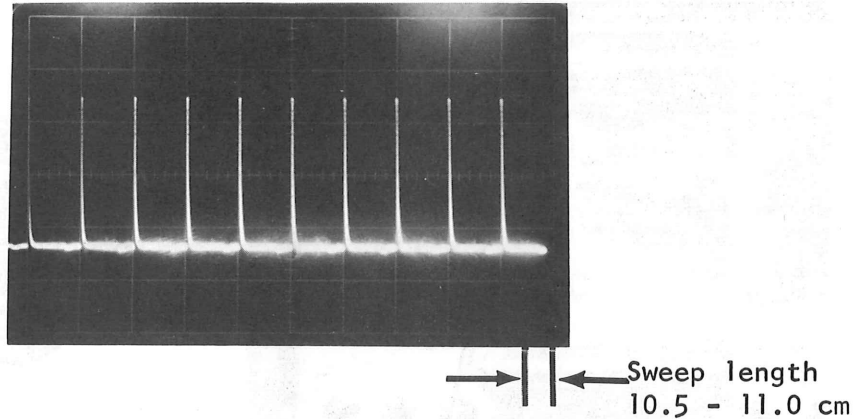

Figure 20

### D. SWEEP MAG. REGISTAR Adjustment

1. With the TIME/CM control set to 1 msec/cm position, pull to unlatch the MAGNIFIER knob and set to 20  $\mu$ sec/cm (X50 MAG.)
2. Apply from the 180A, 100  $\mu$ sec markers and adjust TRIG. LEVEL control if necessary for stable display.
3. Position the start of the sweep to mid-screen with the first marker on the center graticule line. See Figure 21.

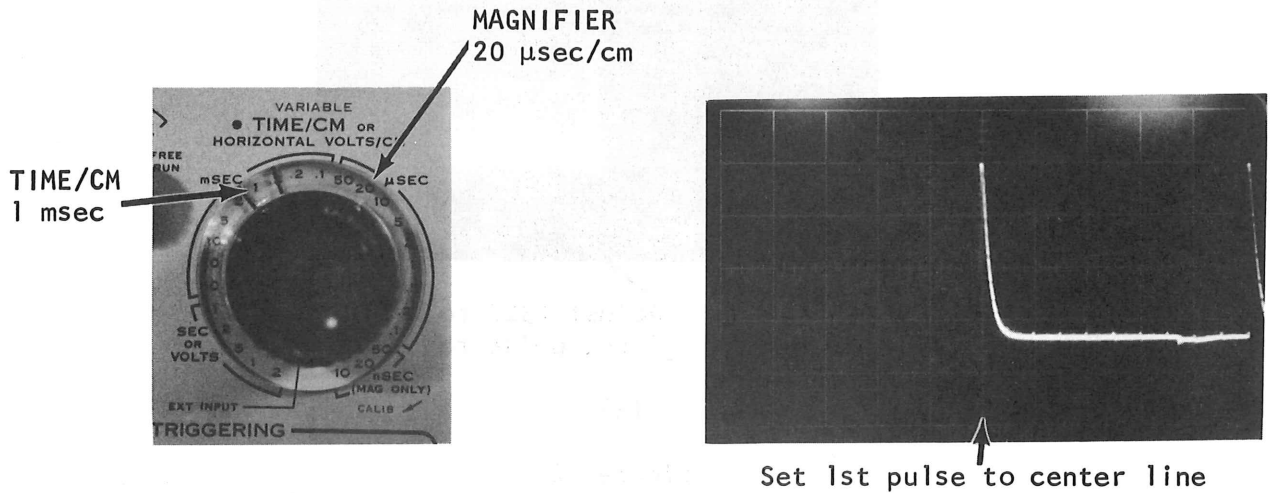
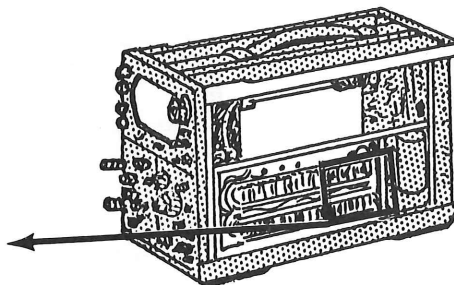
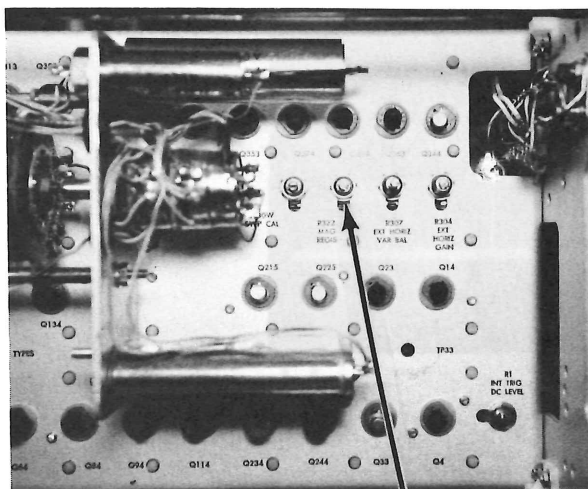

Figure 21

4. Set the MAGNIFIER knob to 1 msec/cm (X1) and adjust MAG. REGISTRAR (R322 - see Figure 22A) to place the first marker again on the center graticule line. See Figure 22B.



R322 MAG. REGIS

(A)

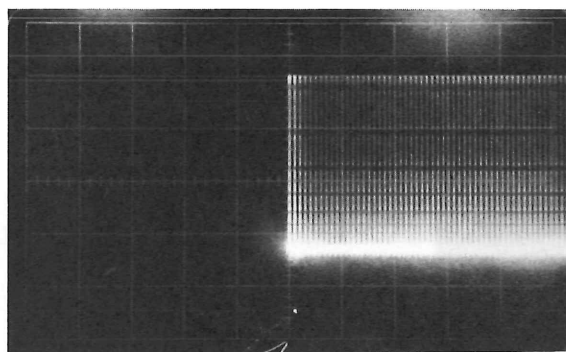

Adjust R322 to position  
first pulse to center of CRT

(B)

Figure 22

5. Repeat the above steps until the first marker is stationary when switching from X50 to X1.
6. Return MAGNIFIER control to 1 msec/cm (X1).



E. MAGNIFIER CHECK

1. Set basic sweep speed (TIME/CM) and MAGNIFIER according to the table below.
2. Apply 180A time-markers as listed and check for correct timing.

<u>TIME/CM</u>	<u>MAGNIFIER</u>	<u>180 SIGNAL</u>	<u>MARKERS/CM</u>	<u>MAX. ERROR</u>
1 msec	.5 msec	500 $\mu$ sec	1/cm	1.6 mm
1 msec	.2 msec	100 $\mu$ sec	2/cm	1.6 mm
1 msec	.1 msec	100 $\mu$ sec	1/cm	1.6 mm
1 msec	50 $\mu$ sec	50 $\mu$ sec	1/cm	1.6 mm
1 msec	20 $\mu$ sec	10 $\mu$ sec	2/cm	1.6 mm
5 msec	2 msec	1 msec	2/cm	1.6 mm
5 msec	.2 msec	100 $\mu$ sec	2/cm	1.6 mm
2 msec	.5 msec	500 $\mu$ sec	1/cm	1.6 mm
2 msec	50 $\mu$ sec	50 $\mu$ sec	1/cm	1.6 mm

3. Return MAGNIFIER and TIME/CM controls to 1 msec/cm position.

F. SLOW and MEDIUM SPEED TIMING

1. Set the TIME/CM switch and apply 180A time-markers according to the following table. Check for correct timing. In all reference to settings of the TIME/CM control, the MAGNIFIER is assumed to be at the same setting, (X1). Adjust TRIG LEVEL, if necessary, to obtain a stable display).

<u>TIME/CM</u>	<u>180 SIGNAL</u>	<u>CHECK FOR</u>	<u>MAX. ERROR</u>
10 $\mu$ sec	10 $\mu$ sec	1 mark/cm	0.8 mm
20 $\mu$ sec	10 $\mu$ sec	2 mark/cm	0.8 mm
50 $\mu$ sec	50 $\mu$ sec	1 mark/cm	0.8 mm
.1 msec	100 $\mu$ sec	1 mark/cm	0.8 mm
.2 msec	100 $\mu$ sec	2 mark/cm	0.8 mm
.5 msec	500 $\mu$ sec	1 mark/cm	0.8 mm
2 msec	1 msec	2 mark/cm	0.8 mm
5 msec	5 msec	1 mark/cm	0.8 mm
10 msec	10 msec	1 mark/cm	0.8 mm
20 msec	10 msec	2 mark/cm	0.8 mm
50 msec	50 msec	1 mark/cm	0.8 mm
.1 sec	100 msec	1 mark/cm	2.0 mm
.2 sec	100 msec	2 mark/cm	2.0 mm
.5 sec	500 msec	1 mark/cm	2.0 mm
1 sec	1 sec	1 mark/cm	2.0 mm
2 sec	1 sec	2 mark/cm	2.0 mm

G. HIGH SPEED TIMING Adjustment

1. Set TIME/CM control to 1  $\mu$ sec/cm (MAGNIFIER to X1 - 1  $\mu$ sec/cm) and apply from the 180A, 1  $\mu$ sec markers. Adjust LEVEL control for a stable display.
2. Adjust C180C (See Figure 23) for 1 pulse/cm.

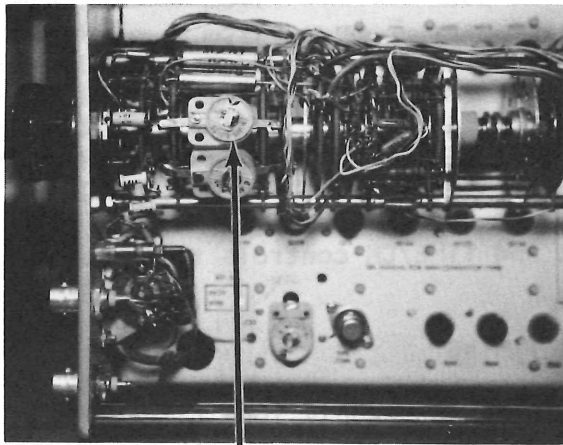

C180C

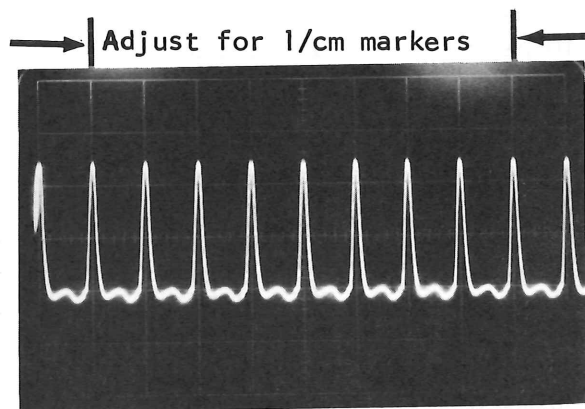
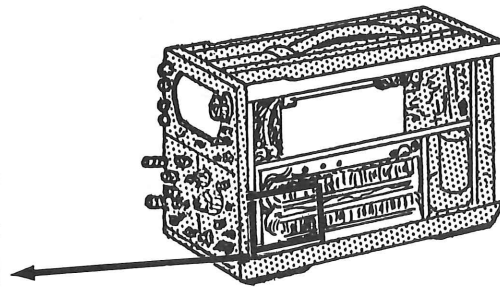
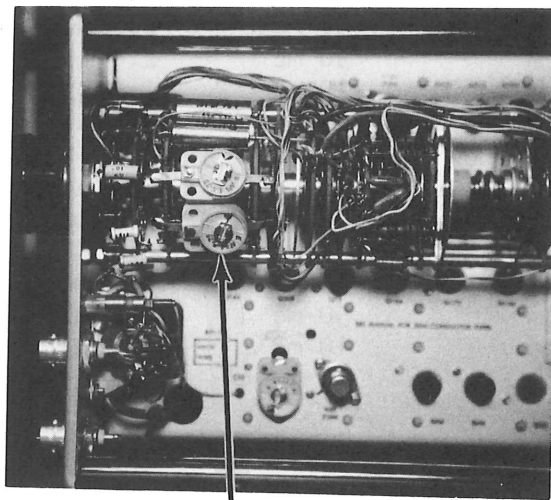

Figure 23

3. Check timing at 2  $\mu$ sec/cm and 5  $\mu$ sec/cm  $\pm 0.8$  max. tolerance.

4. Set the TIME/CM to .1  $\mu$ sec position and apply 10 MC sine-wave from the 180A. Adjust LEVEL and H. F. STABILITY control if necessary, to obtain a stable display.
5. Adjust C180A for 1 sine-wave per cm. See Figure 24.



C180A

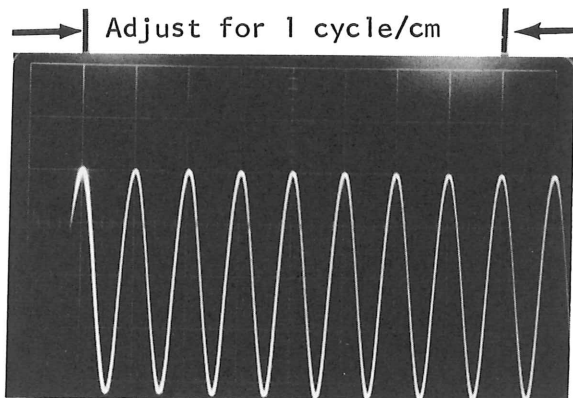
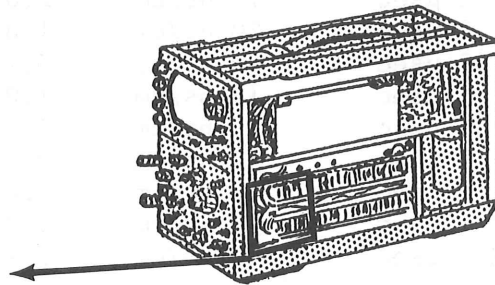

Figure 24

6. Check timing at .2  $\mu$ sec/cm and .5  $\mu$ sec/cm  $\pm$ 0.8 mm max. tolerance.

#### H. HIGH SPEED MAG. CHECK

1. Set the TIME/CM and MAGNIFIER controls and apply 180A time marker according to the following table.
2. Check for correct timing at beginning, middle, and end of the sweep excluding the first 1% of the unmagnified sweep.

<u>TIME/CM</u>	<u>MAGNIFIER</u>	<u>EXCLUDE</u>	<u>180A SIGNAL</u>	<u>MAX. ERROR</u>
.5 $\mu$ sec	10 ns/cm	5.0 cm	50 mc	2.0 mm
.5 $\mu$ sec	20 ns/cm	2.5 cm	50 mc	2.0 mm
.5 $\mu$ sec	50 ns/cm	1.0 cm	10 mc	1.6 mm
.2 $\mu$ sec	10 ns/cm	2.0 cm	50 mc	2.0 mm
.2 $\mu$ sec	20 ns/cm	1.0 cm	50 mc	2.0 mm
.2 $\mu$ sec	50 ns/cm	0.4 cm	10 mc	1.6 mm
.1 $\mu$ sec	10 ns/cm	1.0 cm	50 mc	2.0 mm
.1 $\mu$ sec	20 ns/cm	0.4 cm	50 mc	2.0 mm
.1 $\mu$ sec	50 ns/cm	0.2 cm	10 mc	1.6 mm
1 $\mu$ sec	20 ns/cm	5.0 cm	50 mc	2.0 mm
1 $\mu$ sec	50 ns/cm	2.0 cm	10 mc	1.6 mm
2 $\mu$ sec	50 ns/cm	0.2 cm	10 mc	1.6 mm

3. Disconnect the 180A time-mark signal.

### III. EXT. HORIZONTAL ADJUSTMENTS and CHECKS

#### A. EXT. HORIZONTAL BALANCE

1. Preset 11B1 front panel controls as follows:

TIME/CM	EXT. INPUT
MAGNIFIER	.1 volts/cm
TRIGGERING	
SLOPE	+
COUPLING	AC
SOURCE	EXT (not $\div 10$ )

See Figure 25.

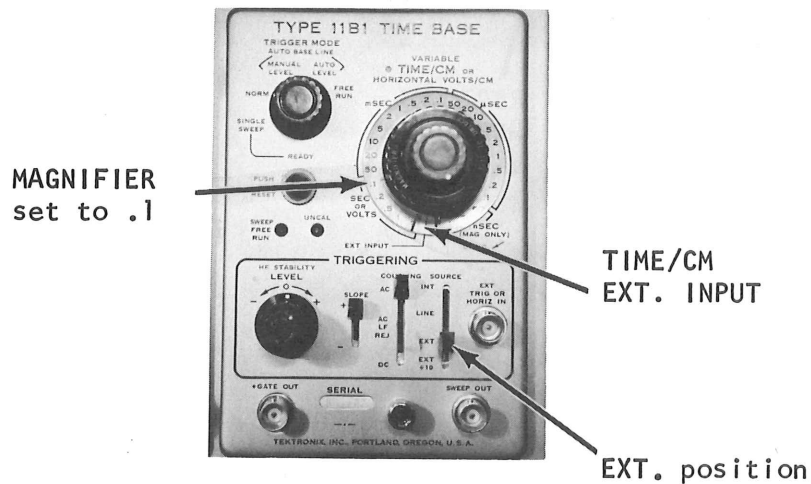
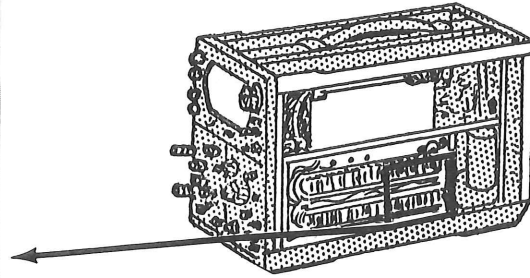
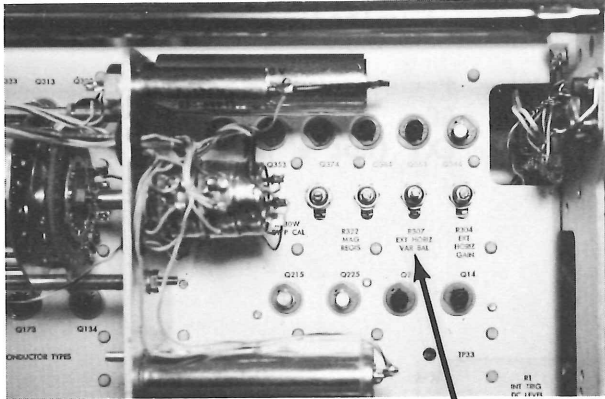

Figure 25

2. Push the trace finder button and turn up intensity until a spot is visible. Release the trace finder and position spot near the center of the screen.

3. Rotate TIME/CM VARIABLE control to extreme CCW and adjust EXT. HORIZONTAL BAL. (R307 - see Figure 26A) to return spot to its former position. See Figure 26B.



R307 EXT.  
HORIZONTAL  
VAR. BAL.

(A)

No HORIZ. movement  
at both extremes of  
VARIABLE control.

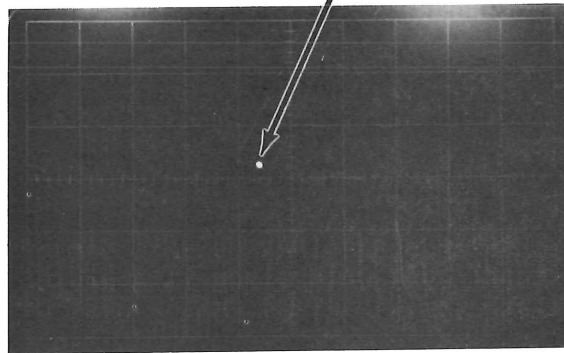

(B)

Figure 26

B. EXT. HORIZONTAL GAIN

1. Using the same front panel preset arrangement as in step A, set the CALIBRATOR control to .5 volt position.
2. Apply the .5 v CAL SIGNAL to the EXT. TRIG or HORIZ. IN connector. See Figure 27.

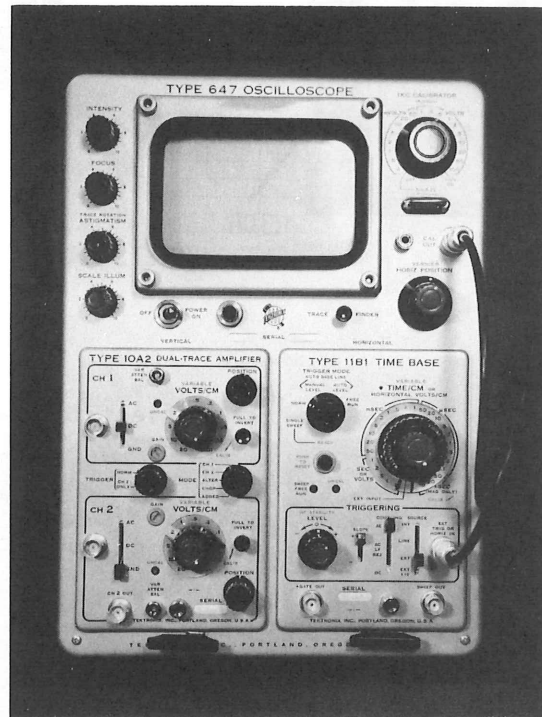

Figure 27

3. Adjust EXT. HORIZ. GAIN (R304 - see Figure 28) for 5 cm of display.

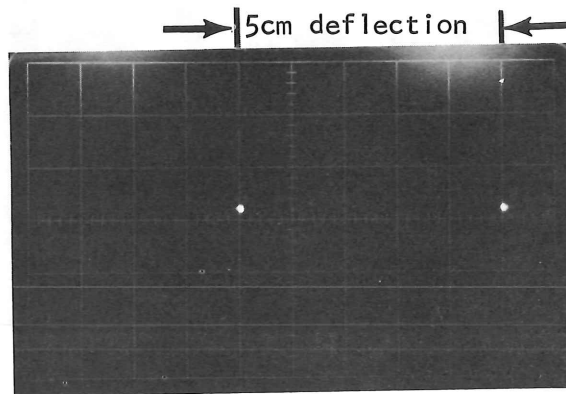
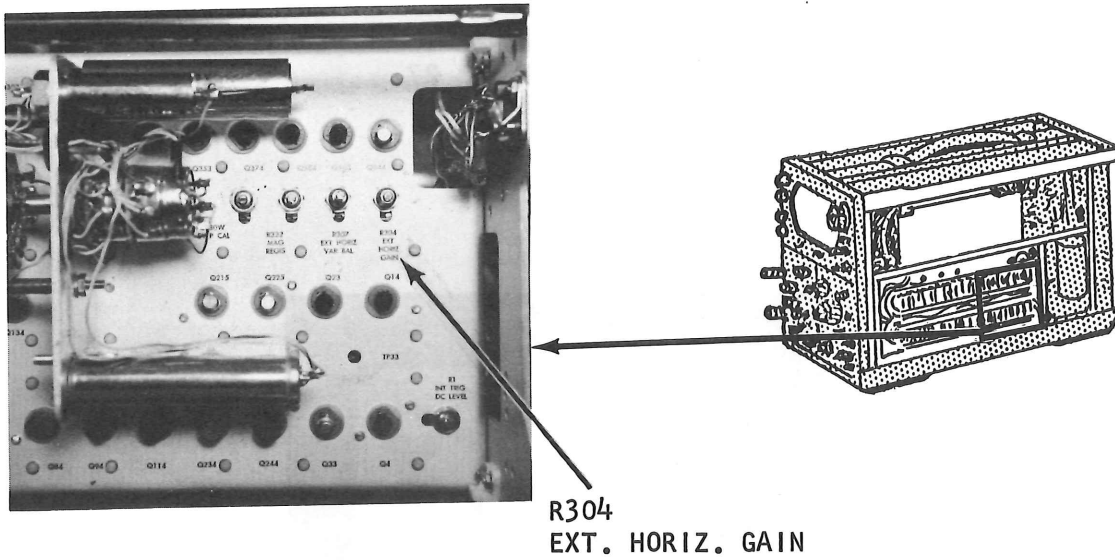

Figure 28

4. Change the MAGNIFIER (HORIZ. volts) to 1 v/cm and the CAL. signal output to 10 v. Check for 10 cm of display.
5. Rotate VARIABLE fully CCW and note HORIZ. deflection is reduced to 4 cm or less (2.5:1 ratio).



C. EXT. HORIZ. Compensation

1. Front panel controls should be set as follows:

TIME/CM	EXT. INPUT
MAGNIFIER (HORIZ.volts)	1 v/cm
SOURCE	EXT. (not $\div$ 10)
SLOPE	+
COUPLING	DC

A test scope is used to obtain the sawtooth signal. 530-540-550 or 580 series can be used.

2. Set the test scope TIME/CM control to .5 msec/cm and the triggering source to EXT.
3. Set the 647 CALIBRATOR to 5 volts position and connect the CAL output, through a "Tee" connector to the 11B1 EXT. INPUT and the test scope EXT. trigger input.
4. Connect the test scope sawtooth signal to the 647 vertical input (if a X10 probe is used, set the vertical volts/cm control to 2v. - otherwise set to 20 v/cm position).
5. Adjust the test scope STABILITY and TRIG. LEVEL controls to obtain a triggered display on the 647. See Figure 29.

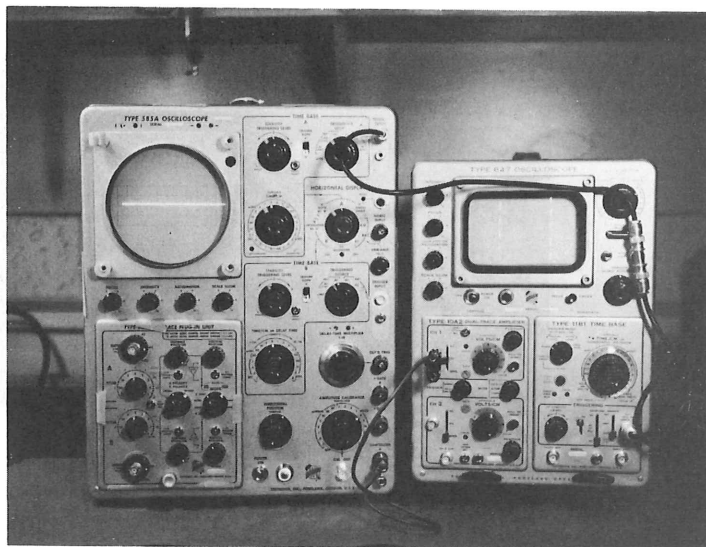
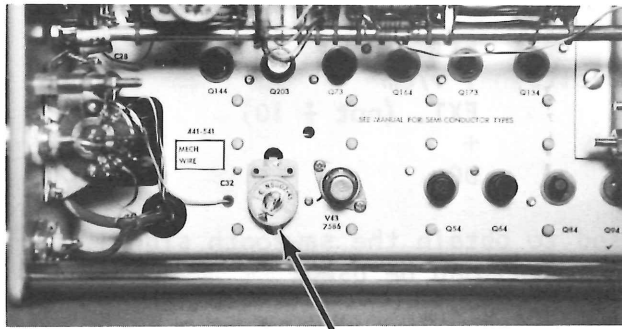
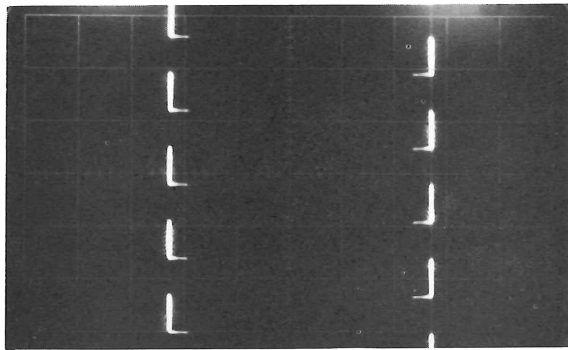
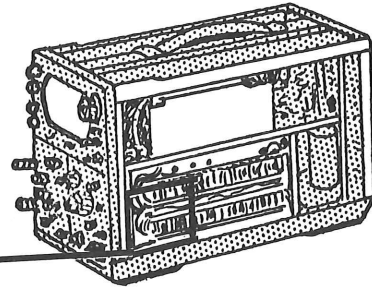

Figure 29

6. Adjust C32 (see Figure 30) for best square corner.



C32



Incorrect Adjustment

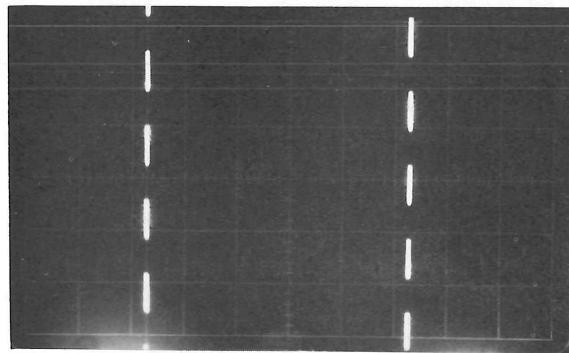
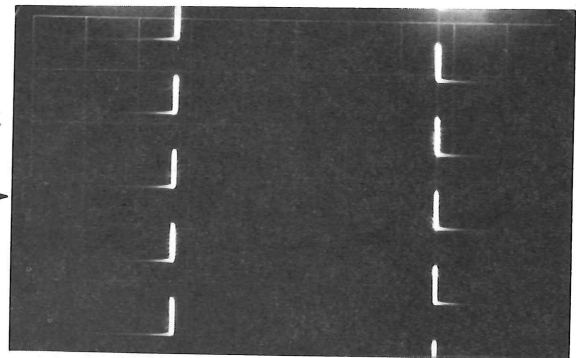

Correct Adjustment

Figure 30

7. Set 11B1 source control to EXT.  $\div 10$  position and the MAGNIFIER (HORIZ. volts) to .1 v/cm.
8. Adjust C28 (see Figure 31) for best square corner.

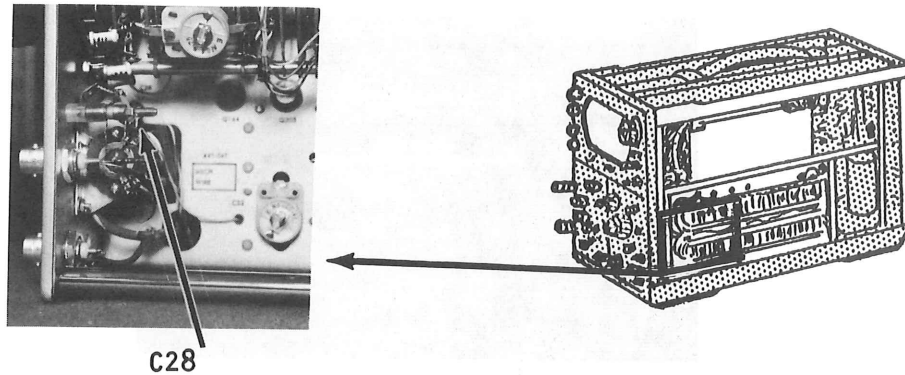

Figure 31

9. Remove the test scope sawtooth connection and EXT. trig. connection.

D. EXT. HORIZ. Bandpass

1. Preset controls as follows

TIME/CM	EXT. INPUT
MAGNIFIER	.1 v/cm
SOURCE	EXT (not $\div 10$ )

2. Connect the type 190B sine-wave generator to the EXT. TRIG or HORIZ. INPUT connection using a UHF to BNC adapter. See Figure 32.

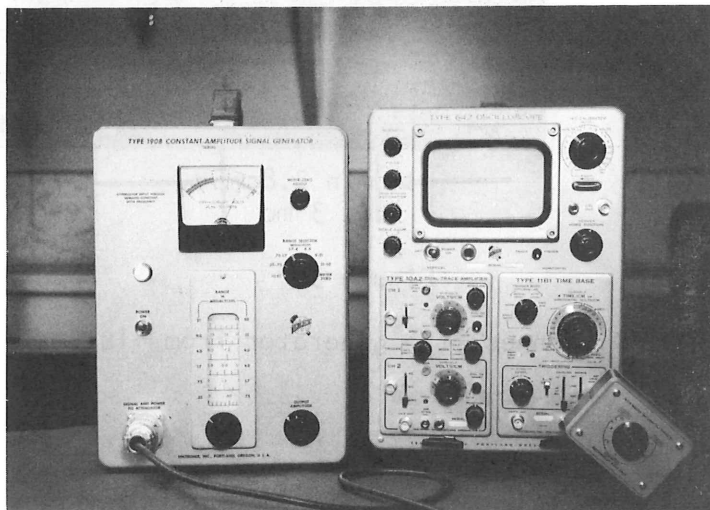

Figure 32

3. Adjust INTENSITY control for normal intensity display.
4. Set the generator frequency to 50 KC and output 190 amplitude to produce a four centimeter peak-to-peak horizontal deflection. See Figure 33.

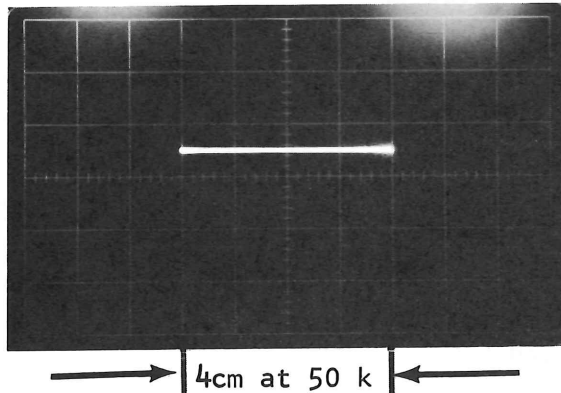

Figure 33

5. Without changing the 190B output amplitude, increase the generator frequency to 3 mc.
6. Check for at least 2.8 cm of horizontal deflection. See Figure 34.

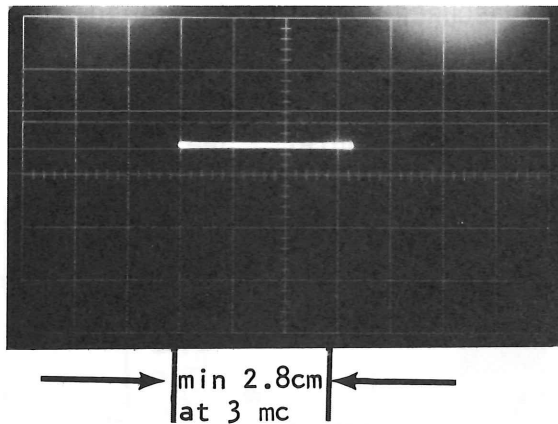

Figure 34

7. Disconnect the generator from 11B1.

#### IV. 11B1 FRONT PANEL WAVEFORMS CHECK

A. Preset 11B1 front panel controls as follows:

TIME/CM	1 $\mu$ sec/cm
MAGNIFIER	X1 (1 $\mu$ sec)
TRIGGER MODE	FREE RUN

B. Using the test oscilloscope, check the following front panel waveforms for correct amplitude.

1. Sweep out  $\approx 10$  volts p-p  $\pm 10\%$

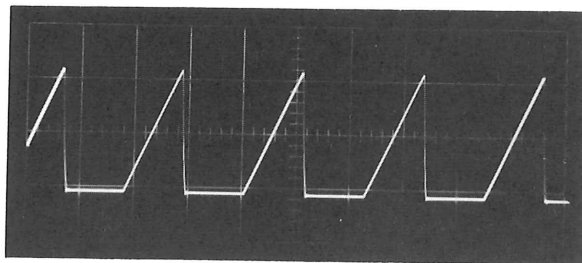

2. + Gate out  $\approx 15$  volts p-p  $\pm 10\%$

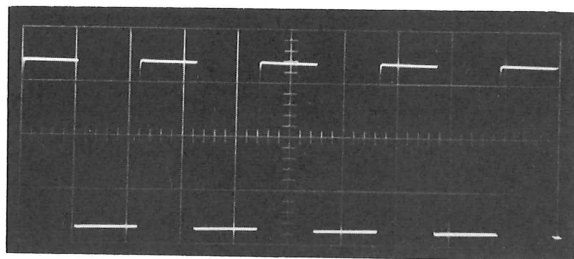



GRAPHIC CALIBRATION PROCEDURE FOR 11B1

(SHORT FORM)

The following calibration procedure is a step-by-step graphic calibration training device. This procedure contains only the information necessary to adjust the five internal calibration controls without test equipment. The timing adjustment is accomplished by utilizing the 647 crystal-controlled 1 KC CALIBRATOR. Adjustments of the two variable timing capacitors which establishes the accuracy of the six fastest sweep rates of the sweep generator is not described because a timing standard other than the 1 KC CALIBRATOR would be required. For a complete calibration, refer to the Long Form Calibration procedure. In this procedure it is assumed that you have a calibrated 647 and a 10-series (10A2) vertical plug-in that is operating properly. The only other piece of equipment required would be a 15-20 inch piece of coaxial with BNC connectors plus an adjustment tool (screw driver).

Remove the cover from the right-hand side of the 647 oscilloscope and apply power to the instrument.

Preset the 11B1 front panel controls as follows:

TIME/CM	EXT INPUT
MAGNIFIER (HORIZ VOLTS)	.1 volts/cm
VARIABLE TIME/CM	CALIB.
TRIG MODE	AUTO BASE LINE-MANUAL LEVEL
TRIGGERING	
SLOPE	+
COUPLING	AC
SOURCE	INT
TRIG LEVEL	0
HF STABILITY	Centered

Preset the VERTICAL PLUG-IN (10A2) front panel controls as follows:

VOLTS/CM	.5
VARIABLE	CALIB.
AC-DC-GND	AC
VERTICAL POSITION	Centered
(DUAL TRACE Plug-In)	
MODE	CH 1
TRIGGER	NORM
Pull to INVERT	Pushed In

Preset 647 front panel controls as follows:

CALIBRATOR	2 Volts
HORIZ POSITION	Centered
INTENSITY	Adjusted to obtain a spot on the CRT.
FOCUS	} Adjusted to obtain a sharp, fine spot.
ASTIGMATISM	



Figure 1 illustrates all the controls in their preset position.

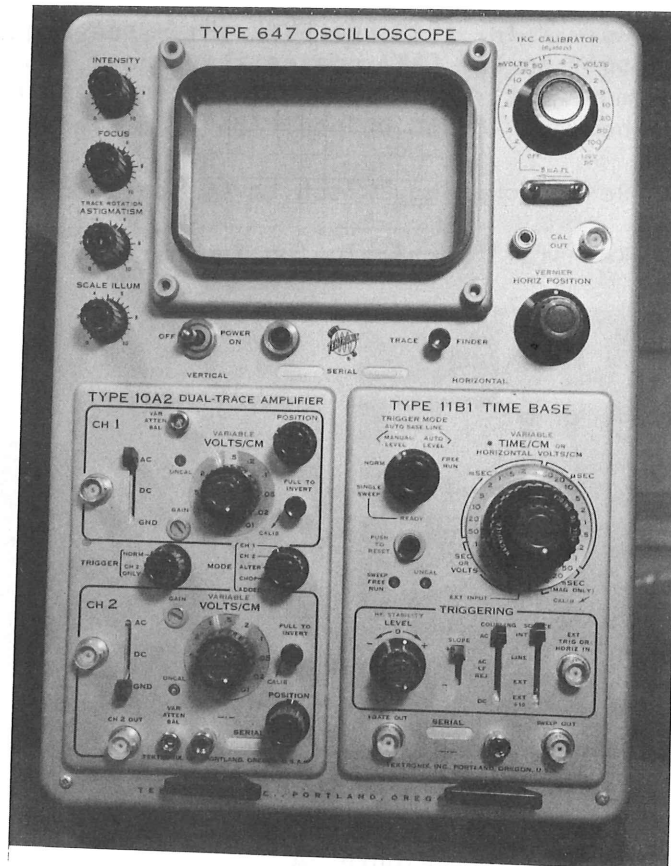

Figure 1

## I. TRIGGERING ADJUSTMENT

### A. INT. TRIG DC LEVEL (R1)

The purpose of R1 is to be able to adjust for zero volts at the output of TRIGGER PREAMP (Emitter of Q33) with zero volts at pins 13 and 15.

1. Partially remove the 10A2 plug-in unit (pulled out sufficiently to disconnect the blue ribbon connectors).
2. Adjust INT TRIG DC LEVEL (R1 - see Figure 2A) so the spot on the CRT remains stationary (no horizontal movement) while moving the TRIGGERING COUPLING switch between AC and DC position (see Figure 2B).
3. Reset coupling switch to AC position.
4. Reinstall vertical plug-in unit.

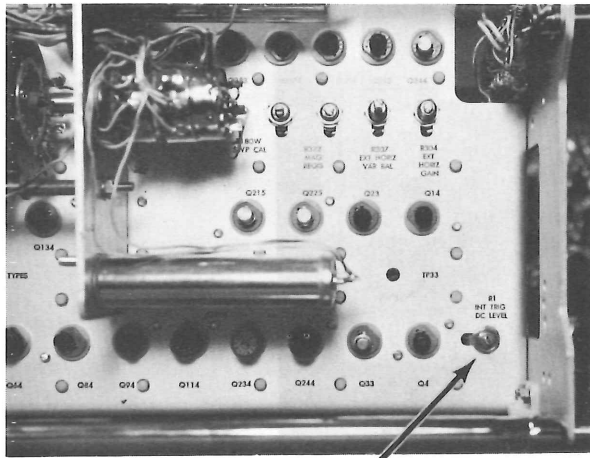

R1 INT TRIG DC LEVEL

Figure 2A

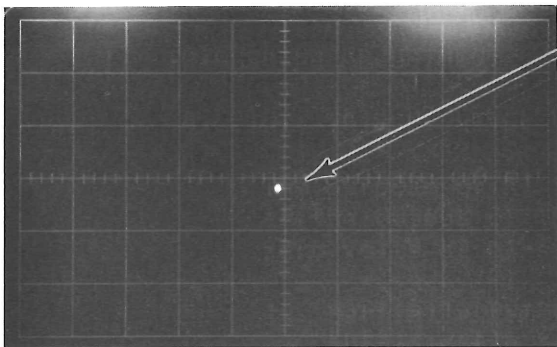
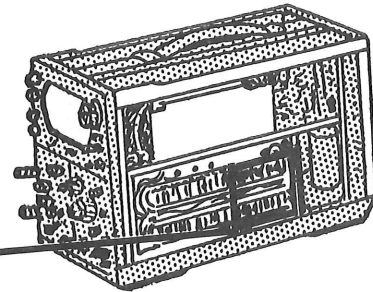

With 10A2 pulled, no horizontal movement of DOT while moving COUPLING switch between AC and DC.

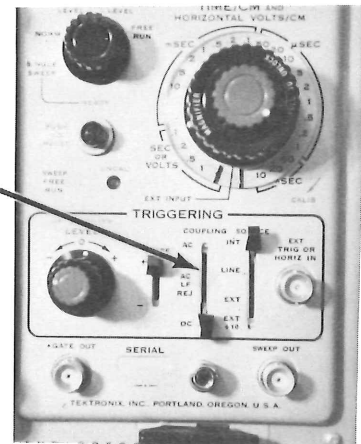

Figure 2B

## II. TIMING ADJUSTMENTS

### A. SWEEP CAL Adjustments

1. Preset the following 11B1 front panel controls:

TIME/CM	1 msec/cm
MAGNIFIER	X1 ( 1 msec )
TRIGGER MODE	AUTO-MANUAL LEVEL
TRIGGERING MODE	
SLOPE	+
COUPLING	AC
SOURCE	INT
LEVEL	0

2. Connect the 1 KC CALIBRATOR signal to the vertical input connector and display approximately 4 cm of signal.
3. Adjust TRIG LEVEL control for a stable display. See Figure 3.

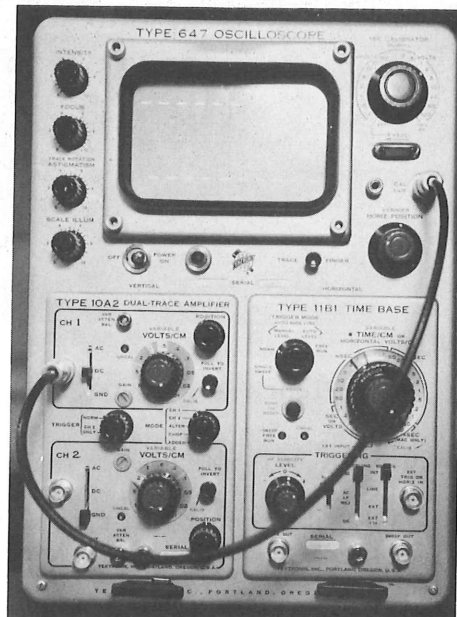
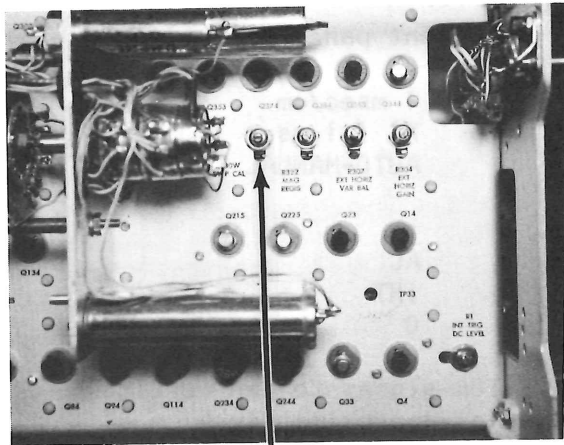

Figure 3

4. Adjust SWP CAL. (R180W - see Figure 4) for 1 pulse/cm as viewed on the middle 8 centimeters.



R180W SWP CAL

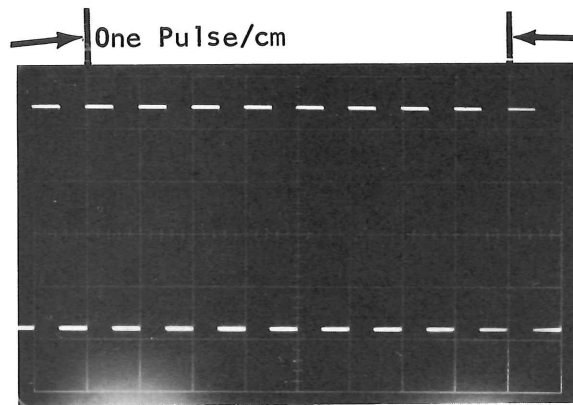
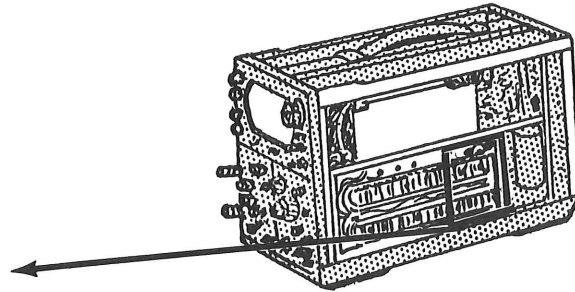

Figure 4

B. SWEEP MAG. REGISTRAR Adjustment

1. With the TIME/CM control set to 1 msec/cm position, pull to unlatch the magnifier knob and set to 20  $\mu$ sec/cm (X50 MAG).

2. With the 1 KC CALIBRATOR signal displayed on the CRT, adjust the HORIZ POSITION control to position the first pulse to the center of the screen. See Figure 5.

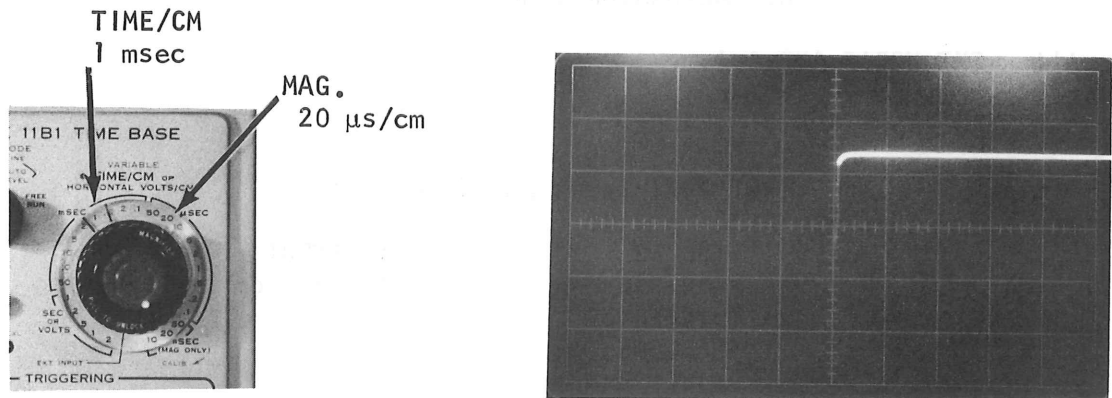
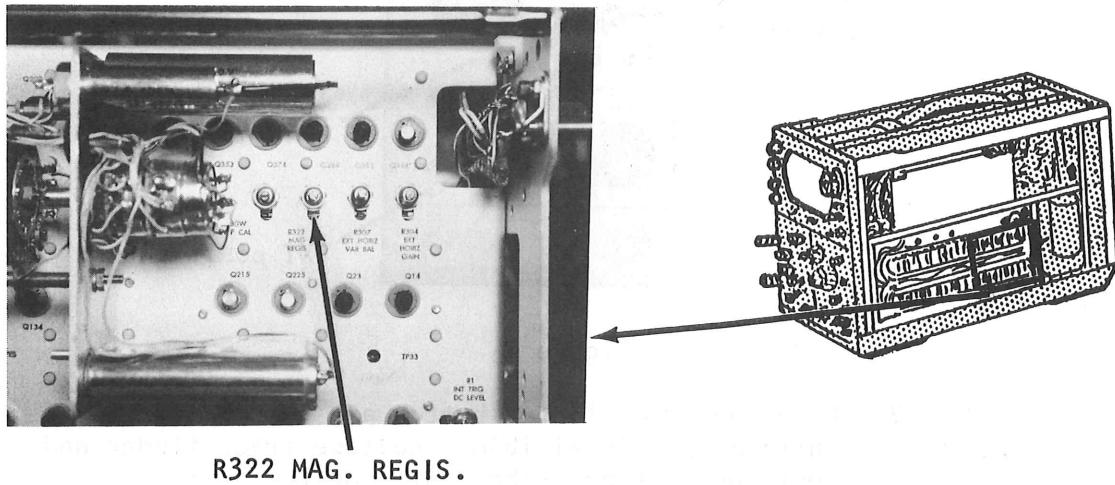

Figure 5

3. Set the MAGNIFIER knob to 1 msec/cm (X1) and adjust MAG. REGIS. (R322 - see Figure 6) so the first pulse is again positioned to the center of the screen. See Figure 6.



Adjust R322 to position start of trace to center.

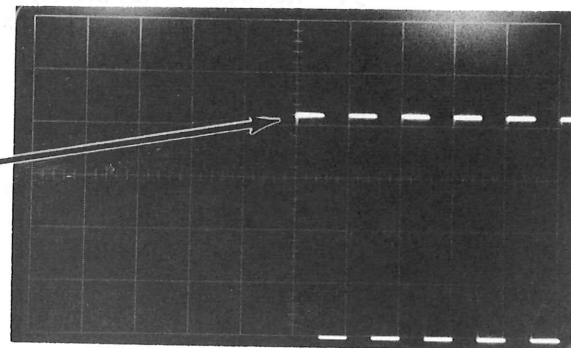

Figure 6

4. Repeat the above steps until there is no horizontal shift of the first pulse rising edge.
5. Turn MAGNIFIER to X1 position (1 msec) and disconnect 1 KC CALIBRATOR signal.

III. EXT HORIZ AMP Adj.

A. EXT HORIZ BALANCE

1. Preset 11B1 front panel controls.

TIME/CM	EXT INPUT
MAGNIFIER	.1 volts/cm
TRIGGERING	
SLOPE	+
COUPLING	AC
SOURCE	EXT (not $\div 10$ )

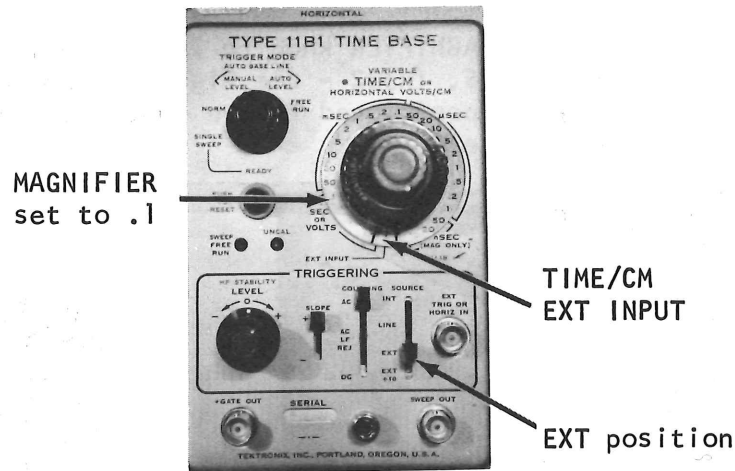
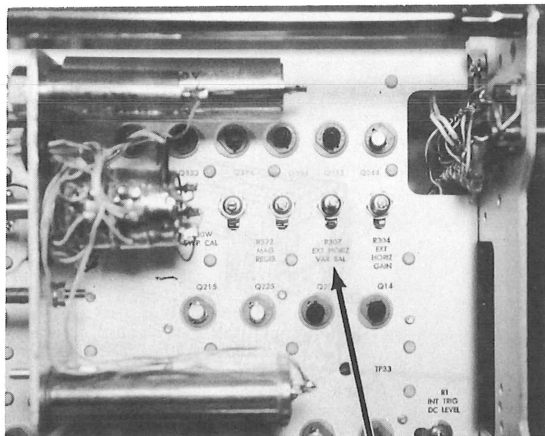
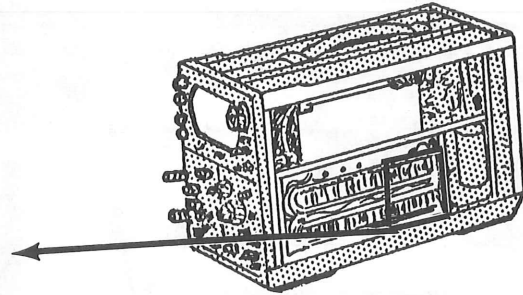

Figure 7

2. Push the trace finder button and turn up intensity until a spot is visible. Release trace finder and position spot near the center of the screen.
3. Rotate TIME/CM VARIABLE control to extreme CCW and adjust EXT HORIZ BAL. (R307 - see Figure 8) to return spot to its former position.
4. Continue to rotate the VARIABLE control between extremes and adjust EXT HORIZ BAL until spot is located in the same position at both ends of the VARIABLE control. Some spot movement may occur as the VARIABLE is rotated through the middle of its range.



R307 EXT HORIZ VAR. BAL



No HORIZ. movement at both extremes of VARIABLE control.

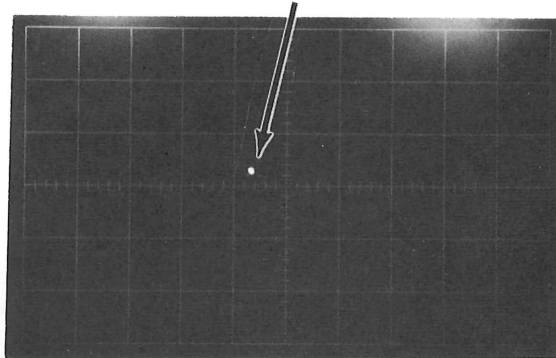
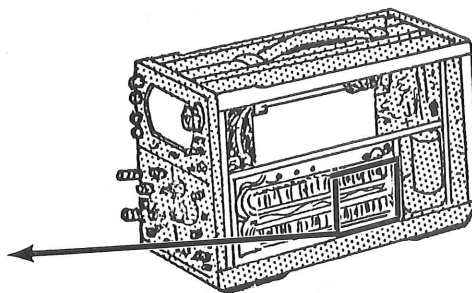
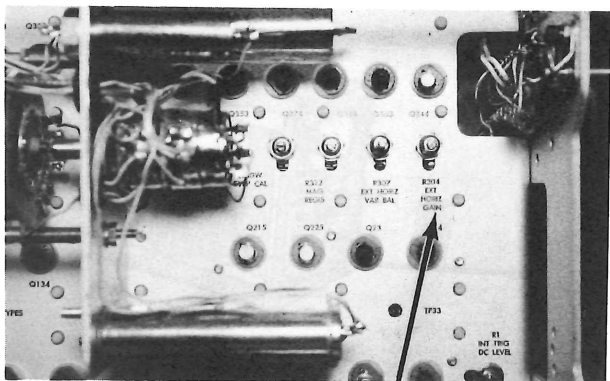

Figure 8

B. EXT HORIZ Gain

1. With the TIME/CM control set to EXT INPUT and MAGNIFIER to .1 v/cm position, apply .5 volts CAL signal to the EXT HORIZ connector. See Figure 9.
2. Adjust EXT HORIZ GAIN (R304 - see Figure 9) for 5 cm of display.



R304 EXT HORIZ GAIN

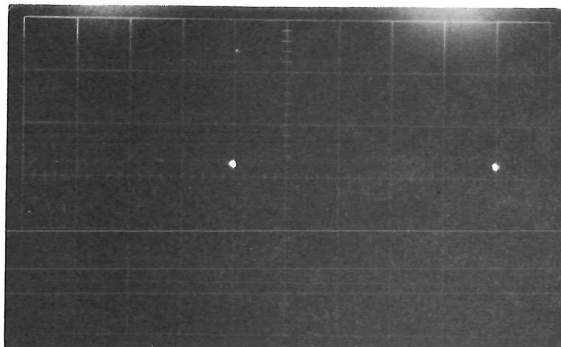
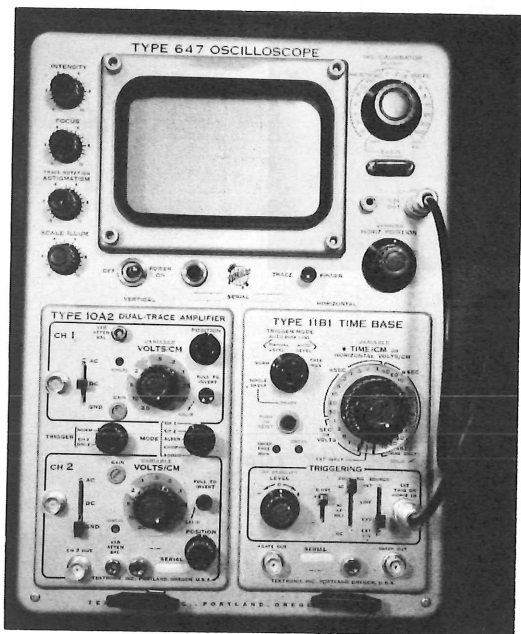

Figure 9



# SECTION 4

## MAINTENANCE AND CALIBRATION

### Introduction

Maintenance of the Type 11B1 is similar to that described for the oscilloscope. Therefore, use the maintenance procedures given in the oscilloscope instruction manual as a guide for maintaining the Type 11B1.

Recalibrate the instrument after each 500 hours of operation, or every six months if used intermittently. It may also be necessary to recalibrate certain sections of the instrument when tubes, transistors, or other components are replaced.

This section of the manual contains a calibration and verification procedure. The title of each numbered step begins either with "Adjust" or "Check", thereby identifying the step function as calibration or verification. The steps are identified in this manner because any or all groups of numbered "Checks" can be skipped without disrupting the continuity of the procedure. However, adjustments must be completed in the order given and none should be skipped. Remember that proper overall operation is obtained only when all steps in the procedure have been completed.

Steps 1, 6, 9, 19, and 21 may be used as an abridged adjustment procedure for adjusting all 5 internal calibration potentiometers. If a marker generator is not available for steps 6 and 9, the 1 kc calibrator in the Type 647 may be substituted.

#### NOTE

The performance standards described in this section of the manual are provided strictly as guides to calibration of the Type 11B1 and should not be construed as advertised performance specifications. However, if the Type 11B1 performs within the guide tolerances given in the calibration procedure, it will also perform as listed in the Characteristics section of this manual.

### CALIBRATION AND VERIFICATION

#### Equipment Required

1. Oscilloscope such as the Tektronix Type 647. This procedure assumes that the oscilloscope has been properly calibrated independent of the plug-in units.
2. Tektronix 10-Series vertical plug-in unit such as the 10A2. This unit need not be calibrated, but must operate in all respects.
3. Constant-amplitude sine-wave generator such as the Tektronix Type 190A or 190B. Required characteristics: (a) output frequencies of 50 kc, 3 mc, and 50 mc, (b) output voltage adjustable from about 0.3 volt to 4.0 volts peak-to-peak when terminated in 50  $\Omega$ , and (c) provisions for maintaining constant amplitude (manually or automatically) with a change in frequency.
4. Tektronix 50  $\Omega$  BNC termination, part no. 011-049, 2 required.
5. UHF-BNC adapter, for connecting the Type 190A or 190B to the BNC termination (UG-255/U).
6. Tektronix P6006 or P6008 Probe.
7. Time-mark generator such as the Tektronix Type 180A. Markers required at 1 and 5 sec; 100, 10, and 1 msec; 100, 50, 10, 5 and 1  $\mu$ sec; 5, 10, and 50 mc sine wave. All outputs should have a time accuracy of at least 0.1%.
8. Coaxial cables, fittings, and adjustment tools as required.

### Preliminary Instructions

1. Remove the access panels from the oscilloscope.
2. Set the controls and switches as follows:

#### Oscilloscope

INTENSITY	Low brightness
1 KC CALIBRATOR	1 VOLTS

#### Type 11B1

TIME/CM OR HORIZONTAL VOLTS/CM	EXT INPUT
MAGNIFIER	.1 VOLTS
COUPLING	AC
SOURCE	INT
SLOPE	+
VARIABLE	CALIB
TRIGGERING LEVEL	0

#### Vertical Plug-in Unit

#### NOTE

If a multi-trace plug-in unit is used, use Channel 1.

MODE	CH 1
VOLTS/CM	.5
VARIABLE	CALIB
AC-DC-GND	DC
PULL TO INVERT Position	Pushed in Spot centered
TRIGGER	NORM

3. Apply power to the instruments and allow several minutes for warmup before beginning calibration.

#### NOTE

Photographs on a foldout page following the schematics in the back of this manual show the the location of each calibration adjustment and test point.

### Procedure

#### 1. Adjust INT TRIG DC LEVEL (R1)

- a. Remove the vertical plug-in unit.

## Maintenance and Calibration—Type 11B1

- b. Adjust INT TRIG DC LEVEL (R1) so the spot remains stationary as the COUPLING switch is switched back and forth between AC LF REJ and DC.
- c. Reset the COUPLING switch to AC and reinstall the vertical plug-in unit.

### 2. Check Free-Run Mode

- a. Set TIME/CM OR HORIZONTAL VOLTS/CM to 5 mSEC.
- b. Set the TRIGGER MODE switch to FREE RUN and check for a trace on the crt.

### 3. Check Normal Mode

- a. Set the TRIGGER MODE switch to NORM and check for no trace on the crt.
- b. Set:  
SOURCE switch to LINE  
COUPLING switch to AC
- c. Connect a 10 $\times$  probe between the vertical input and line frequency signal (such as pin 30, approximately 6.3 volts ac, of the horizontal interconnecting plug in the oscilloscope).
- d. Check that a triggered display can be obtained by adjusting the TRIGGERING LEVEL control. Note whether the display begins within the rising portion of the sine wave.
- e. Set the SLOPE switch to — and repeat step (d). The display should begin within the opposite portion of the sine wave (rise or fall) from that noted in step (d).
- f. Set the COUPLING switch to AC LF REJ and the SLOPE switch to +; then repeat steps (d) and (e).
- g. Disconnect the probe.

### 4. Check Single-Sweep Mode

- a. Set:  
TRIGGERING LEVEL control to 0  
SLOPE switch to +  
TIME/CM OR HORIZONTAL VOLTS/CM to 50 mSEC  
TRIGGER MODE switch to SINGLE SWEEP  
SOURCE switch to EXT
- b. Check that the RESET lamp is not lit and that there is no trace on the crt.
- c. Push the RESET button and check to see that it lights.
- d. Watch the crt and set the SOURCE switch to LINE. The Sweep Generator should produce only one sweep on the crt and the RESET lamp should extinguish.

### 5. Check Auto Base Line—Manual LEVEL MODE

- a. Set:  
SOURCE switch to EXT  
TIME/CM OR HORIZONTAL VOLTS/CM to 10  $\mu$ SEC

TRIGGER MODE switch to AUTO BASE LINE—  
MANUAL LEVEL  
COUPLING to AC

- b. Terminate the constant-amplitude sine-wave generator with a Tektronix 50  $\Omega$  BNC termination unit (part no. 011-049), using a UHF to BNC adapter (part no. 103-032). Apply the signal to the EXT TRIG OR HORIZ IN connector.
- c. Set the vertical plug-in VOLTS/CM switch to .01.
- d. Connect a Tektronix P6006 or P6008 Probe between the vertical input and the terminal on the rear of the EXT TRIG OR HORIZ IN connector. Connect the probe-body ground lead to the Type 11B1 chassis.
- e. Set the generator for a 150 mv peak-to-peak output (measured on the face of the crt).
- f. Adjust the TRIGGERING LEVEL control for a stable display.
- g. Check that a stable sine-wave display can be obtained with the SLOPE switch set to either + or —.
- h. Set the SOURCE switch to INT and reduce the amplitude of the signal for 2 mm of vertical deflection. Repeat steps (f) and (g).
- i. Repeat steps (f) and (g) with the COUPLING switch set to DC.
- j. Set the generator for a 250 mv peak-to-peak output (measured on the face of the crt).
- k. Repeat steps (f) and (g) with the COUPLING switch set to AC LF REJ.
- l. Set the output amplitude of the generator to 450 mv; then change the generator frequency to 50 mc.

#### NOTE

The input amplitude may be verified with a sampling oscilloscope system using a probe such as the Tektronix P6034. This probe should be connected in parallel with the probe used in step (d) and should be left connected through step (n).

- m. Set:  
TIME/CM OR HORIZONTAL VOLTS/CM to .1  $\mu$ SEC  
MAGNIFIER switch to 10 nSEC  
COUPLING switch to AC  
SOURCE switch to EXT
- n. Repeat steps (f) and (g).
- o. Set the SOURCE switch to INT and reduce the amplitude of the input signal for 1 cm of vertical deflection. Check that a stable display can be obtained. It may be necessary to use the HF STABILITY control to obtain a stable display.
- p. Disconnect the generator.
- q. Set:  
SOURCE switch to EXT  $\div$  10  
TIME/CM OR HORIZONTAL VOLTS/CM and MAGNIFIER switches to 1 mSEC  
Vertical plug-in VOLTS/CM switch to 2  
1 KC CALIBRATOR switch (oscilloscope) to 5 VOLTS

# Maintenance Note

## Maintenance and Calibration—Type 11B1

- b. Adjust INT TRIG DC LEVEL (R1) so the spot remains stationary as the COUPLING switch is switched back and forth between AC LF REJ and DC.
- c. Reset the COUPLING switch to AC and reinstall the vertical plug-in unit.

### 2. Check Free-Run Mode

- a. Set TIME/CM OR HORIZONTAL VOLTS/CM to 5 mSEC.
- b. Set the TRIGGER MODE switch to FREE RUN and check for a trace on the crt.

### 3. Check Normal Mode

- a. Set the TRIGGER MODE switch to NORM and check for no trace on the crt.
- b. Set:  
SOURCE switch to LINE  
COUPLING switch to AC
- c. Connect a 10X probe between the vertical input and line frequency signal (such as pin 30, approximately 6.3 volts ac, of the horizontal interconnecting plug in the oscilloscope).
- d. Check that a triggered display can be obtained by adjusting the TRIGGERING LEVEL control. Note whether the display begins within the rising portion of the sine wave.
- e. Set the SLOPE switch to — and repeat step (d). The display should begin within the opposite portion of the sine wave (rise or fall) from that noted in step (d).
- f. Set the COUPLING switch to **DC** and the SLOPE switch to +; then repeat steps (d) and (e).

- #
- #
- #
- g. Switch COUPLING to AC LF REJ and SOURCE to INT and check that sweep cannot be triggered.
  - h. Disconnect the probe.

### 4. Check Single-Sweep Mode

- a. Set:  
TRIGGERING LEVEL control to 0  
SLOPE switch to +  
TIME/CM OR HORIZONTAL VOLTS/CM to 50 mSEC  
TRIGGER MODE switch to SINGLE SWEEP  
SOURCE switch to EXT
- b. Check that the RESET lamp is not lit and that there is no trace on the crt.
- c. Push the RESET button and check to see that it lights.
- d. Watch the crt and set the SOURCE switch to LINE. The Sweep Generator should produce only one sweep on the crt and the RESET lamp should extinguish.

### 5. Check Auto Base Line—Manual LEVEL MODE

- a. Set:  
SOURCE switch to EXT

TIME/CM OR HORIZONTAL VOLTS/CM to 10  $\mu$ SEC

TRIGGER MODE switch to AUTO BASE LINE—  
MANUAL LEVEL  
COUPLING to AC

- b. Terminate the constant-amplitude sine-wave generator with a Tektronix 50  $\Omega$  BNC termination unit (part no. 011-049), using a UHF to BNC adapter (part no. 103-032). Apply the signal to the EXT TRIG OR HORIZ IN connector.
- c. Set the vertical plug-in VOLTS/CM switch to .01.
- d. Connect a Tektronix P6006 or P6008 Probe between the vertical input and the terminal on the rear of the EXT TRIG OR HORIZ IN connector. Connect the probe-body ground lead to the Type 11B1 chassis.
- e. Set the generator for a 150 mv peak-to-peak output (measured on the face of the crt).
- f. Adjust the TRIGGERING LEVEL control for a stable display.
- g. Check that a stable sine-wave display can be obtained with the SLOPE switch set to either + or —.
- h. Set the SOURCE switch to INT and reduce the amplitude of the signal for 2 mm of vertical deflection. Repeat steps (f) and (g).
- i. Repeat steps (f) and (g) with the COUPLING switch set to DC.
- j. Set the generator for a 250 mv peak-to-peak output (measured on the face of the crt).
- k. Repeat steps (f) and (g) with the COUPLING switch set to AC LF REJ.
- l. Set the output amplitude of the generator to 450 mv; then change the generator frequency to 50 mc.

### NOTE

The input amplitude may be verified with a sampling oscilloscope system using a probe such as the Tektronix P6034. This probe should be connected in parallel with the probe used in step (d) and should be left connected through step (n).

m. Set:

TIME/CM OR HORIZONTAL VOLTS/CM to .1  $\mu$ SEC  
MAGNIFIER switch to 10 nSEC  
COUPLING switch to AC  
SOURCE switch to EXT

- n. Repeat steps (f) and (g).
- o. Set the SOURCE switch to INT and reduce the amplitude of the input signal for 1 cm of vertical deflection. Check that a stable display can be obtained. It may be necessary to use the HF STABILITY control to obtain a stable display.
- p. Disconnect the generator.
- q. Set:

SOURCE switch to EXT  $\div$  10  
TIME/CM OR HORIZONTAL VOLTS/CM and  
MAGNIFIER switches to 1 mSEC  
Vertical plug-in VOLTS/CM switch to 2  
1 KC CALIBRATOR switch (oscilloscope) to 5  
VOLTS





- r. Connect the oscilloscope calibrator output to the EXT TRIG OR HORIZ IN connector and to the vertical input.
- s. Check that a stable display can be obtained by setting the TRIGGERING LEVEL control.
- t. Remove the signal connections.

**6. Adjust SWP CAL (R180W)**

- a. Set:
  - TRIGGER MODE switch to AUTO BASE LINE—MANUAL LEVEL
  - SOURCE switch to INT
  - COUPLING switch to AC
  - SLOPE switch to +
  - TIME/CM OR HORIZONTAL VOLTS/CM and MAGNIFIER switches to 1 mSEC
  - Vertical plug-in unit VOLTS/CM switch to 2
- b. Apply 1 msec markers to the vertical input.
- c. Set the TRIGGERING LEVEL control for a stable display.
- d. Adjust SWP CAL (R180W) so that the 1st and 9th markers (not counting the marker at the extreme left end of the trace) falls on the 2nd and 10th vertically scribed marks on the graticule (see Fig. 4-1).
- e. Check the sweep timing on both the 2 mSEC and 5 mSEC position of the TIME/CM OR HORIZONTAL VOLTS/CM switch.

**7. Check Sweep Length and Horizontal Position Range**

- a. Return TIME/CM OR HORIZONTAL VOLTS/CM and MAGNIFIER switches to 1 mSEC.
- b. Position the second marker to left edge of graticule (1 cm of the trace outside the left edge of the graticule).

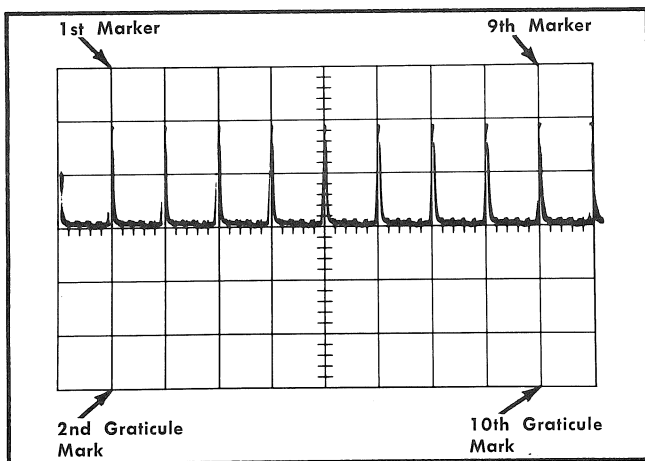

Fig. 4-1. Counting of time markers and graticule marks.

- c. Check that the sweep terminates in the last 1/2 cm of the graticule (i.e., the sweep length is 10.5 to 11 cm long).
- d. Turn the oscilloscope HORIZ POSITION and VERNIER controls fully counterclockwise. Check that the right edge of the trace is at least 2 mm to the left of the graticule center.
- e. Turn the oscilloscope HORIZ POSITION and VERNIER controls fully clockwise. Check that the left edge of the trace is at least 2 mm to the right of the graticule center.
- f. Return the trace to mid-screen. Check that the range of the VERNIER control moves the trace at least 2 mm.

**8. Check VARIABLE Control Range**

- a. Set up the equipment as is step 6.
- b. Turn the VARIABLE control fully counterclockwise. Check that there are 4 markers/cm (range, 2.5:1).

**9. Adjust MAG REGIS (R322)**

- a. Set up the Type 11B1 as in step 6.
- b. Apply 100 μsec markers and adjust TRIGGERING LEVEL control to obtain a stable display.
- c. Pull the MAGNIFIER switch outward and set to 20 μSEC/CM (×50 magnification).
- d. Position the start of the sweep to mid-screen with the first markers on the center graticule line.
- e. Set the MAGNIFIER switch to 1 mSEC/CM (×1) and adjust MAG REGIS control R322 to again place the first marker on the center graticule line.
- f. Repeat steps (b) through (d) until the first marker is stationary when the MAGNIFIER switch is turned from ×1 through ×50.

**10. Adjust High-Speed Timing**

- a. Set TIME/CM OR HORIZONTAL VOLTS/CM and MAGNIFIER switches to 1 μSEC.
- b. Set TRIGGER MODE switch to AUTO BASE LINE—MANUAL LEVEL.
- c. Apply 1 μsec markers to the vertical plug-in.
- d. Adjust C180C for 1 marker/cm with the 1st and 9th markers (not counting the marker on the extreme left) falling exactly on the 2nd and 10th graticule marks.
- e. Set TIME/CM OR HORIZONTAL VOLTS/CM switch to .1 μSEC.
- f. Apply 10 mc markers to the vertical plug-in.
- g. Adjust C180A for 1 marker/cm with the 1st and 9th markers (not counting the marker on the extreme left) falling exactly on the 2nd and 10th graticule marks.

**11. Check Slow and Medium Speed Timing**

- a. Set the TIME/CM OR HORIZONTAL VOLTS/CM switch and apply markers as listed in Table 4-1.

## Maintenance and Calibration—Type 11B1

- b. Set the TRIGGER MODE switch to NORM and obtain a stable display.
- c. Check the accuracy of the sweep timing at the 2nd and 10th vertically scribed lines on the graticule.

**TABLE 4-1**

TIME/CM	Check For	Time Markers	Max. Error
10 $\mu$ SEC	10 $\mu$ sec	1 mark/cm	$\pm 1.2$ mm
20 $\mu$ SEC	10 $\mu$ sec	2 marks/cm	$\pm 1.2$ mm
50 $\mu$ SEC	50 $\mu$ sec	1 mark/cm	$\pm 1.2$ mm
.1 mSEC	100 $\mu$ sec	1 mark/cm	$\pm 1.2$ mm
.2 mSEC	100 $\mu$ sec	2 marks/cm	$\pm 1.2$ mm
.5 mSEC	500 $\mu$ sec	1 mark/cm	$\pm 1.2$ mm
10 mSEC	10 msec	1 mark/cm	$\pm 1.2$ mm
20 mSEC	10 msec	2 marks/cm	$\pm 1.2$ mm
50 mSEC	50 msec	1 mark/cm	$\pm 1.2$ mm
.1 SEC	100 msec	1 mark/cm	$\pm 2.4$ mm
.2 SEC	100 msec	2 marks/cm	$\pm 2.4$ mm
.5 SEC	500 msec	1 mark/cm	$\pm 2.4$ mm
1 SEC	1 sec	2 marks/cm	$\pm 2.4$ mm
2 SEC	1 sec	2 marks/cm	$\pm 2.4$ mm

### 12. Check MAGNIFIER

- a. Set the basic speed (TIME/CM OR HORIZONTAL

VOLTS/CM) and MAGNIFIER switches according to columns 1 and 2 of Table 4-2.

- b. Apply markers to the vertical plug-in as listed in column 4.
- c. Check for marks/cm as listed in column 5. Maximum error should be less than  $\pm 2.8$  mm.

### 13. Check High Speed Magnification

- a. Set the basic sweep speed (TIME/CM OR HORIZONTAL VOLTS/CM and MAGNIFIER switches) according to columns 1 and 2 of Table 4-3.
- b. Apply a sine-wave signal to the vertical plug-in as listed in column 3.
- c. Check the cycles/cm as listed in column 4.
- d. Turn the oscilloscope HORIZ POSITION control and check the beginning, middle, and end of the sweep. Exclude the first 1% portion of the sweep. With the magnified sweep positioned so that the start of the sweep is at the left edge of the graticule, the number of cm listed in column 5 represents 1% of the unmagnified sweep.
- e. Check that the error does not exceed the tolerance listed in column 6. Make the tolerance readings between the 2nd and 10th vertically inscribed lines of the graticule.

**TABLE 4-2**

TIME/CM	MAGNIFIER	$\times$ Magnification	Time Markers	Check For
1 mSEC	.5 mSEC	$\times 2$	500 $\mu$ sec	1 mark/cm
1 mSEC	.2 mSEC	$\times 5$	100 $\mu$ sec	2 marks/cm
1 mSEC	.1 mSEC	$\times 10$	100 $\mu$ sec	1 mark/cm
1 mSEC	50 $\mu$ SEC	$\times 20$	50 $\mu$ sec	1 mark/cm
1 mSEC	20 $\mu$ SEC	$\times 50$	10 $\mu$ sec	2 marks/cm
5 mSEC	2 mSEC	$\times 2.5$	1 msec	2 marks/cm
5 mSEC	.2 mSEC	$\times 25$	100 $\mu$ sec	2 marks/cm
2 mSEC	.5 mSEC	$\times 4$	500 $\mu$ sec	1 mark/cm
2 mSEC	50 $\mu$ SEC	$\times 40$	50 $\mu$ sec	1 mark/cm

**TABLE 4-3**

TIME/CM	MAGNIFIER	Signal	Check For	1st 1% is	Tolerance
.5 $\mu$ SEC	10 nSEC	50 mc	1 cycle/2 cm	5.0 cm	$\pm 2.8$ mm
.2 $\mu$ SEC	10 nSEC	50 mc	1 cycle/2 cm	2.0 cm	$\pm 2.8$ mm
.1 $\mu$ SEC	10 nSEC	50 mc	1 cycle/2 cm	1.0 cm	$\pm 2.8$ mm
1 $\mu$ SEC	20 nSEC	50 mc	1 cycle/cm	5.0 cm	$\pm 2.8$ mm
.5 $\mu$ SEC	20 nSEC	50 mc	1 cycle/cm	2.5 cm	$\pm 2.8$ mm
.2 $\mu$ SEC	20 nSEC	50 mc	1 cycle/cm	1.0 cm	$\pm 2.8$ mm
.1 $\mu$ SEC	20 nSEC	50 mc	1 cycle/cm	0.5 cm	$\pm 2.8$ mm
2 $\mu$ SEC	50 nSEC	10 mc	1 cycle/2 cm	4.0 cm	$\pm 2.4$ mm
1 $\mu$ SEC	50 nSEC	10 mc	1 cycle/2 cm	2.0 cm	$\pm 2.4$ mm
.5 $\mu$ SEC	50 nSEC	10 mc	1 cycle/2 cm	1.0 cm	$\pm 2.4$ mm
.2 $\mu$ SEC	50 nSEC	10 mc	1 cycle/2 cm	0.4 cm	$\pm 2.4$ mm
.1 $\mu$ SEC	50 nSEC	10 mc	1 cycle/2 cm	0.2 cm	$\pm 2.4$ mm

**14. Check Alternate Trace Sync pulse**

- a. Remove the side panels from the oscilloscope.
- b. Connect a 47-pf 10% capacitor from pin 17 of the vertical plug-in connector to ground.
- c. Set the vertical plug-in unit MODE switch to CH 1 or CH 2.
- d. Set the test oscilloscope TIME/CM switch to .05  $\mu$ SEC, the VOLTS/CM switch to .2 VOLTS/CM, the triggering source switch to INT, coupling switch to AC, and the slope switch to —.
- e. Connect the test oscilloscope 10 $\times$  probe to pin 17 of the vertical plug-in unit and check that the pulse amplitude of the alternate trace sync pulse is at least 4 volts peak-to-peak.
- f. Remove the 47 pf capacitor and the probe.

**15. Check AUTO BASE LINE Recovery Time**

- a. Set:  
TIME/CM OR HORIZONTAL VOLTS/CM and  
MAGNIFIER switches to 1 mSEC  
TRIGGERING MODE switch to AUTO BASE  
LINE—MANUAL LEVEL  
COUPLING switch to AC  
SLOPE switch to +  
Vertical plug-in unit VOLTS/CM switch to 2
- b. Connect 50 msec markers and adjust the TRIGGERING LEVEL control for a stable display of the leading edge of the marker. Change to 100 msec markers and note that the sweep cannot be properly triggered on the leading edge of the marker as with the 50 msec markers.

**NOTE**

If the recovery time of the automatic triggering circuit is greater than the interval between trigger pulses, the sweep triggers as in the NORM position of the TRIGGER MODE switch. If the recovery time is less than the interval between pulses, the sweep triggers erratically and cannot be triggered on the leading edge of the marker.

**16. Check AUTO BASE LINE—AUTO LEVEL Operation**

- a. Connect 1 msec markers and adjust the vertical plug-in for 1 cm of deflection.
- b. Set the TRIGGER MODE switch to AUTO BASE LINE—AUTO LEVEL and check for a stable display.

**17. Check +Gate Output**

- a. Connect the test oscilloscope through a 10 $\times$  probe to the + GATE OUT connector of the Type 11B1.
- b. Set the TRIGGER MODE switch to FREE RUN.
- c. Check that the amplitude of the +Gate pulse is 15 volts  $\pm$ 10%.

**18. Check Sweep Output**

- a. Set the TIME/CM OR HORIZONTAL VOLTS/CM switch to 1 mSEC.
- b. Connect the test oscilloscope 10 $\times$  probe to the SWEEP OUT connector.
- c. Check that the sawtooth amplitude is 10 volts  $\pm$ 10%.

**19. Adjust EXT HORIZ VAR BAL (R307)**

- a. Set:  
TIME/CM OR HORIZONTAL VOLTS/CM to EXT  
INPUT  
MAGNIFIER (Horizontal volts) to .1  
SOURCE to EXT  
COUPLING to AC  
SLOPE to +
- b. Push the trace finder on the oscilloscope and turn up the intensity until the spot is visible.
- c. Release the trace finder and position the spot at the center of the crt with HORIZ POSITION controls.
- d. Turn the VARIABLE control fully counterclockwise and adjust the EXT HORIZ VAR BAL control (R307) to return the spot to the center of the crt.
- e. Turn the VARIABLE control fully clockwise and check the movement of the spot.
- f. Work back and forth between the VARIABLE control, the oscilloscope HORIZ POSITION control, and the EXT HORIZ VAR BAL control, and adjust the EXT HORIZ VAR BAL control until the spot is located at the center of the crt when the VARIABLE control is turned to both extremes. Some spot movement may occur as the VARIABLE control is turned through the middle of its range.

**20. Adjust External Horizontal Compensation**

- a. Set:  
TIME/CM OR HORIZONTAL VOLTS/CM to EXT  
INPUT  
MAGNIFIER to 1  
SOURCE to EXT  
COUPLING to DC  
SLOPE to +  
TRIGGER MODE to AUTO BASE LINE—AUTO  
LEVEL  
Vertical Plug-In VOLTS/CM to 2  
Type 647 1 KC CALIBRATOR to 5 VOLTS  
Test Oscilloscope TIME/CM switch to .5 mSEC  
and the triggering SOURCE switch to EXT

## Maintenance and Calibration—Type 11B1

- b. Connect a 10 $\times$  probe from the Type 647 vertical plug-in input to the sawtooth output of the test oscilloscope.
- c. Connect the Type 647 CAL OUT through a "Tee" connector to the Type 11B1 EXT TRIG OR HORIZ IN connector and to the test oscilloscope external trigger input.
- d. Obtain an externally triggered trace on the test oscilloscope.
- e. Adjust C32 in the Type 11B1 for the best square corner on the displayed square wave.
- f. Center the display horizontally on the screen.
- g. Change the Type 11B1 COUPLING switch to AC and check that the display shifts to the left half of the crt.
- h. Return the COUPLING switch to DC, set the SOURCE switch to EXT  $\div$  10, and the MAGNIFIER switch to .1.
- i. Adjust C28 (the trimmer capacitor located next to the EXT TRIGGER OR HORIZ IN connector) for the best square corner.

### 21. Adjust EXT HORIZ GAIN (R304)

- a. Set:
  - Type 647 1 KC CALIBRATOR to .5 VOLTS
  - SOURCE switch to EXT
  - MAGNIFIER switch to .1
- b. Apply the output from the CAL OUT connector to the EXT TRIG OR HORIZ IN connector.
- c. Adjust EXT HORIZ GAIN (R304) for 5 cm of display.
- d. Change the MAGNIFIER (horizontal volts/cm) to 1 and the Type 647 1 KC CALIBRATOR to 10 VOLTS. Check for 10 cm of display.
- e. Turn the VARIABLE control fully counterclockwise and note that the horizontal deflection is reduced to 4 cm maximum.
- f. Return the VARIABLE control to CALIB and remove the calibrator output from the vertical plug-in unit.

### 22. Check the External Horizontal Bandpass

- a. Set:
  - TIME/CM OR HORIZONTAL VOLTS/CM to EXT INPUT
  - SOURCE switch to EXT
  - MAGNIFIER to .1
  - Type 190B Signal Generator frequency to 50 kc

- b. Connect the signal generator output to the input of the vertical plug-in and to the EXT TRIG OR HORIZ IN connector.
- c. Adjust the signal generator output for 6 cm of deflection.
- d. Set the signal generator frequency to 3 mc. Do not change the amplitude setting of the Type 190B.
- e. Check that the deflection is at least 4.2 cm at 3 mc.

### 23. Check External Triggering

- a. Set:
  - TIME/CM OR HORIZONTAL VOLTS/CM and MAGNIFIER switches to 20  $\mu$ SEC
  - SOURCE switch to EXT
  - TRIGGER MODE switch to AUTO BASE LINE—MANUAL LEVEL
  - Type 190B to 50 kc
- b. Place a 50  $\Omega$  termination (Tektronix part no. 011-049) on the input terminal of the vertical plug-in and one on the EXT TRIG HORIZ IN connector.
- c. Connect the Type 190B through a UHF to BNC adapter to a BNC "Tee" connector (UG-274 B/U).
- d. Connect 50  $\Omega$  coaxial cables from the "Tee" connector to the 50  $\Omega$  terminations on the vertical plug-in input connector and the EXT TRIG OR HORIZ IN connector.
- e. Adjust the Type 190B for 2.5 cm of vertical deflection. Check that a stable display can be obtained in both DC + or — SLOPE and in AC + or — SLOPE.
- f. Adjust the Type 190B for 5 cm of vertical deflection. Check that a stable display can be obtained in AC LF REJ + or — SLOPE. Set the Vertical Plug-In VOLTS/CM switch to 5.
- g. Increase the output of the Type 190B to obtain 3.6 cm of vertical deflection. Do not disturb the amplitude adjustment, and set the Type 190B to 50 mc.
- h. Set the TIME/CM OR HORIZONTAL VOLTS/CM switch to .1 /SEC. Set the MAGNIFIER switch to 10 nSEC.
- i. Note that a stable display can be obtained with less than 1 mm of jitter when the TRIGGERING LEVEL and HF STABILITY controls are carefully adjusted.
- j. Remove the cable from the EXT TRIG OR HORIZ IN connector, but leave the connection to the vertical plug-in.
- k. Set the SOURCE switch to INT and adjust the output of the Type 190B to obtain 1 cm of vertical deflection.
- l. Check that a stable display can be obtained with less than 1 mm of jitter when the TRIGGERING LEVEL and HF STABILITY controls are carefully adjusted.



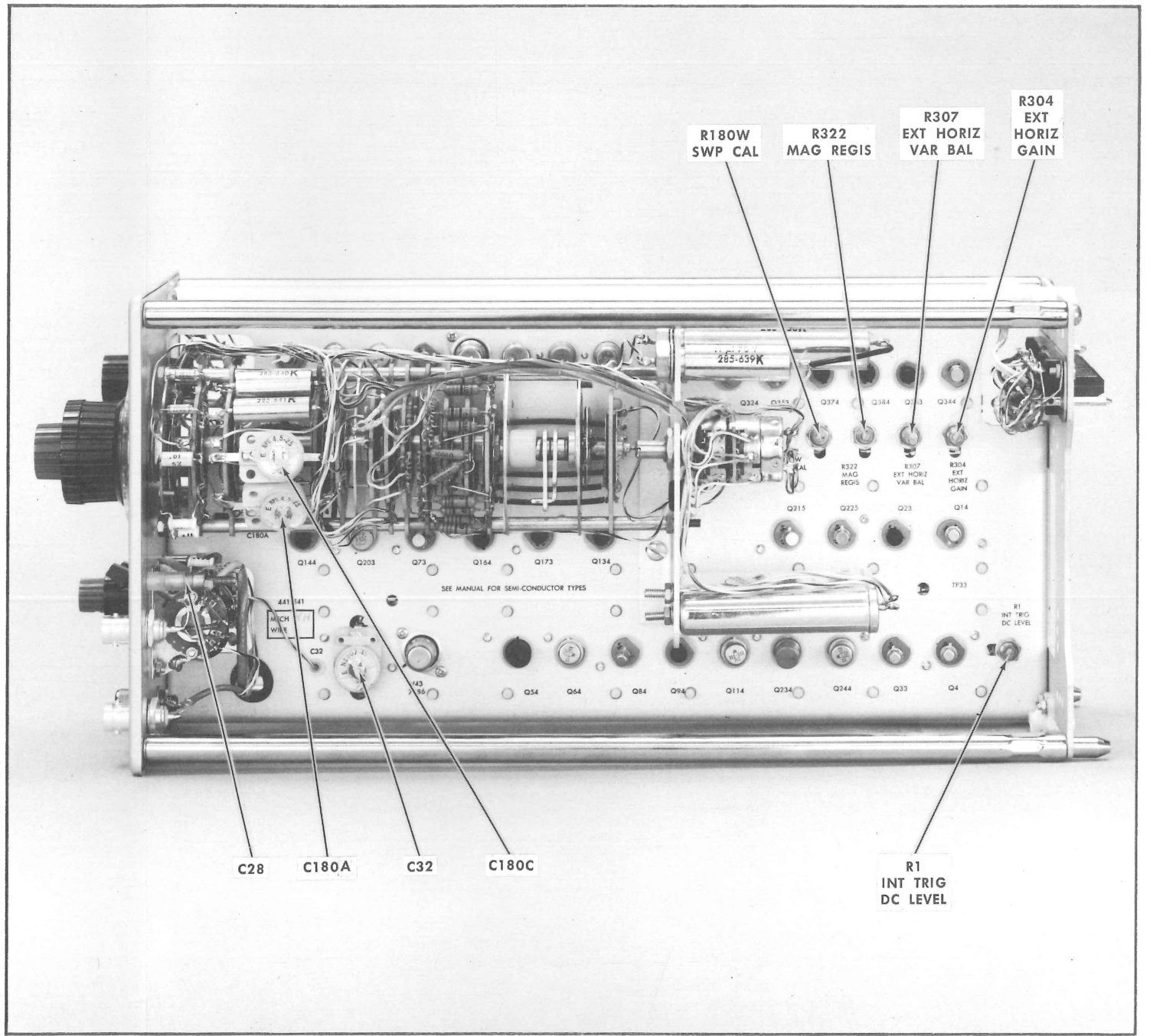

R180W  
SWP CAL

R322  
MAG REGIS

R307  
EXT HORIZ  
VAR BAL

R304  
EXT  
HORIZ  
GAIN

C28

C180A

C32

C180C

R1  
INT TRIG  
DC LEVEL

### INTERCONNECTING PLUG

Resistances to ground with 11B1 removed from oscilloscope.  
Use 1 K scale of 20,000  $\Omega/v$  ohmmeter, except as noted.

#### 11B1 Front-Panel Control Settings

TIME/CM	1 MSEC
VARIABLE	CALIB
MAGNIFIER	1 MSEC
TRIGGER MODE	AUTO MANUAL
SOURCE	INT
COUPLING	AC
SLOPE	+
LEVEL	0

Function	Amphenol	Approx. Resistance		Scale
		When meter lead is		
		(+)	(-)	
-75 V	1	2.1 k	2.1 k	
Unblanking	2	2.6 k	2.6 k	
+15 V	3	35 $\Omega$	35 $\Omega$	×1
Unused	4, 5, 6, 7	inf	inf	
+ Output	8	3 k	8.5 k	
- Output	9	3 k	8.5 k	
Unused	10, 11	inf	inf	
Shield	12, 14, 16	0	0	
Int. Trigger Input	13, 15	100 $\Omega$	100 $\Omega$	
Alt. Trace Sync. Pulse	17	420 $\Omega$	420 $\Omega$	
-15 V	18	650 $\Omega$	650 $\Omega$	
Unused	19	inf	inf	
+100	20	3.7 k	3.3 k	
+270	21	600 k	600 k	×10 k
+15 V (isolated)	22	75 $\Omega$	90 $\Omega$	×10
+15 V	23	35 $\Omega$	35 $\Omega$	×10
C. T. Position Vernier	24	50 k	50 k	
C. T. Position	25	3.5 k	7 k	
Ground	26	0	0	
Ext. Reset	27	100 k	100 k	
Unused	28, 29	inf	inf	
6 VAC for Line Trig.	30	9 k	9 k	
Ground	31, 32	0	0	

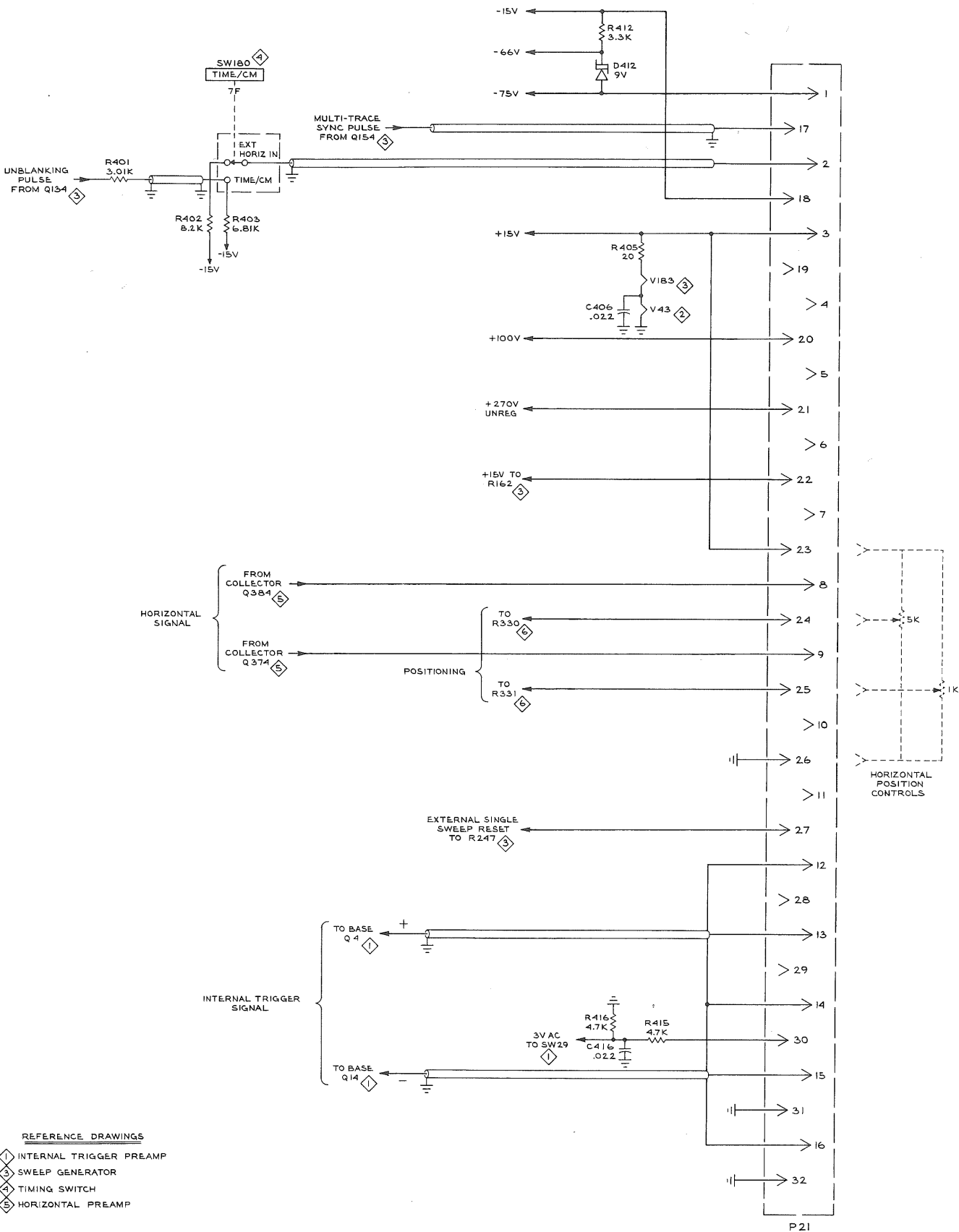

REFERENCE DRAWINGS

- ① INTERNAL TRIGGER PREAMP
- ② SWEEP GENERATOR
- ③ TIMING SWITCH
- ④ HORIZONTAL PREAMP

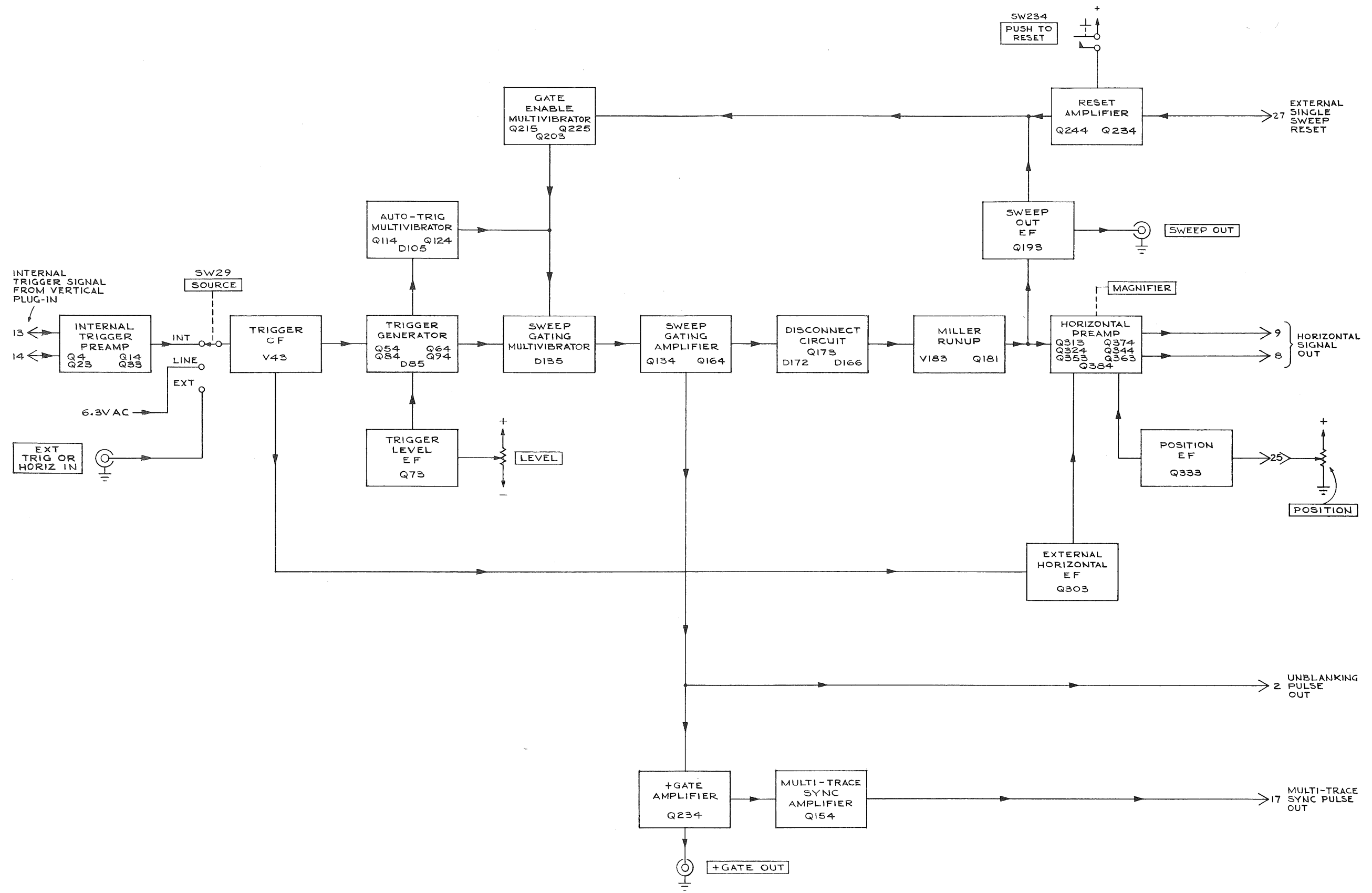

TYPE 11B1 PLUG-IN

A

MRH  
564  
BLOCK DIAGRAM

BLOCK DIAGRAM

### IMPORTANT

The waveform photographs and the voltages shown on the schematics were obtained with a Tektronix Type 545A/CA oscilloscope system using a Type P6027 ( $\times 1$ ) probe. Other equivalent systems may be used. The Type 11B1 was part of an oscilloscope system consisting of a Tektronix Type 647 Oscilloscope, Type 10A2 vertical plug-in, and the Type 11B1.

Signal input to the Type 10A2 at the time the waveform photographs were taken was the 1-kc square-wave output of the Type 647 calibrator. Internal triggering of the Type 11B1 was used except for those photographs where line triggering is specified. No signal input was applied while making the voltage measurements.

Voltages and waveform amplitudes are not absolute, but may vary within the instrument or between instruments.

The Type 11B1 control settings for all measurements are as follows unless otherwise noted:

TIME/CM OR HORIZONTAL VOLTS/CM	1 mSEC
MAGNIFIER	1 mSEC
VARIABLE	CALIB
COUPLING	AC
SOURCE	INT
SLOPE	+
LEVEL	0
HF STABILITY	0
TRIGGER MODE	NORM

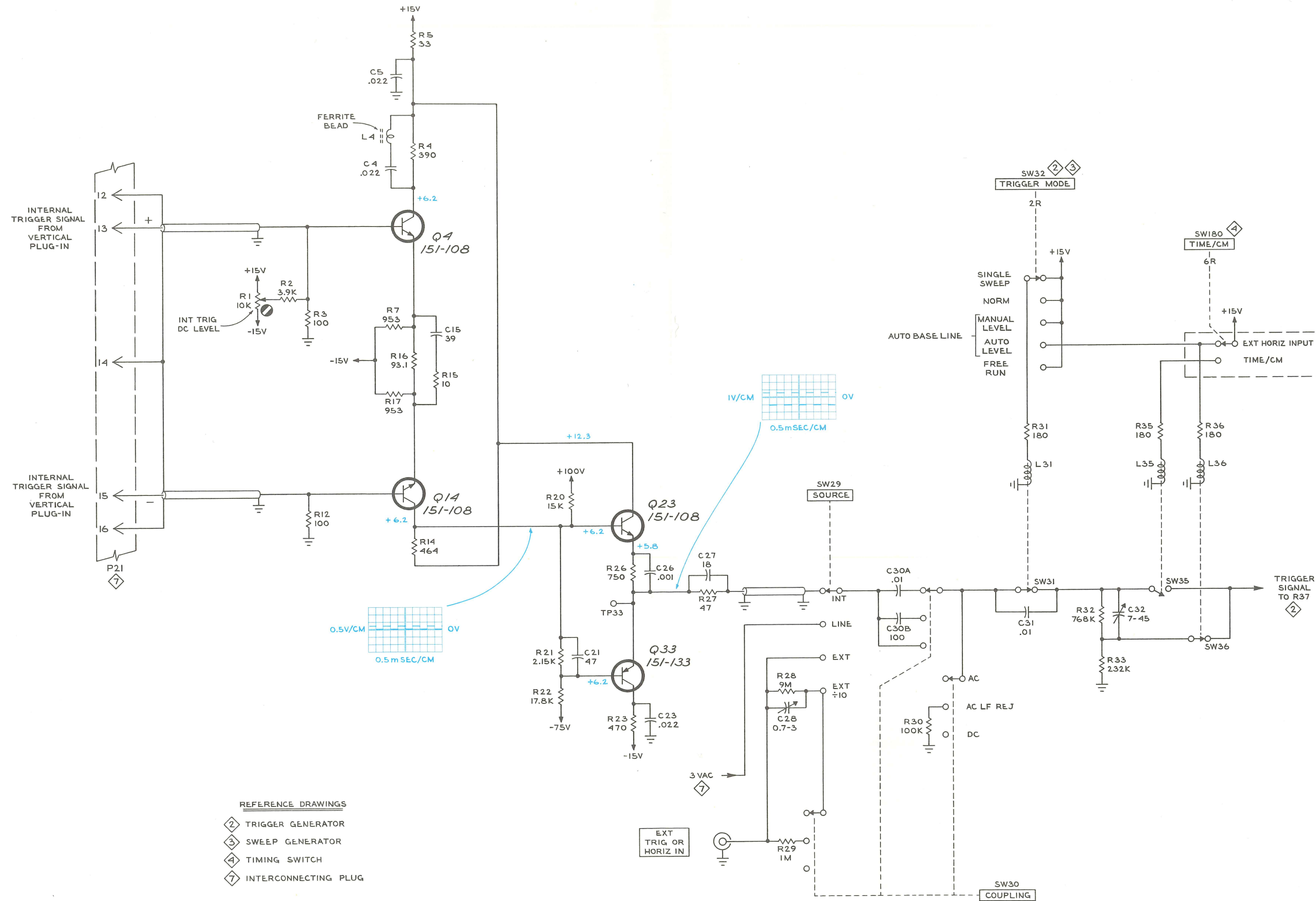

TYPE 11B1 PLUG-IN

A<sub>1</sub>

CMD  
T64  
INTERNAL TRIGGER PREAMP ①

INTERNAL TRIGGER PREAMP

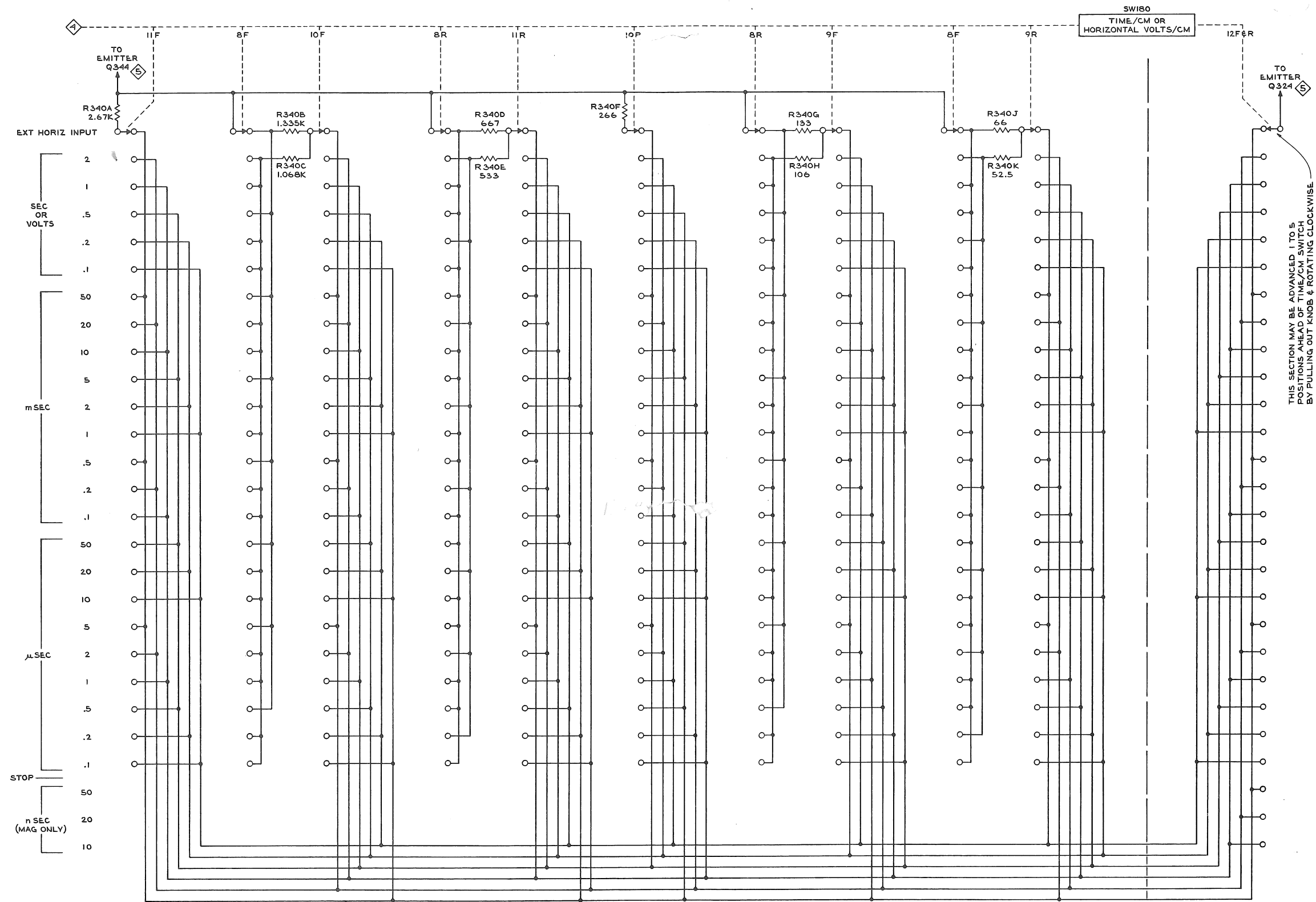

TYPE 11B1 PLUG-IN

A

MAGNIFIER SWITCH

THIS SECTION MAY BE ADVANCED 1 TO 5 POSITIONS AHEAD OF TIME/CM SWITCH BY PULLING OUT KNOB & ROTATING CLOCKWISE

SW180  
TIME/CM OR  
HORIZONTAL VOLTS/CM

REFERENCE DRAWINGS  
 4 TIMING SWITCH  
 5 HORIZONTAL PREAMP  
 CMD  
 564

MAGNIFIER SWITCH



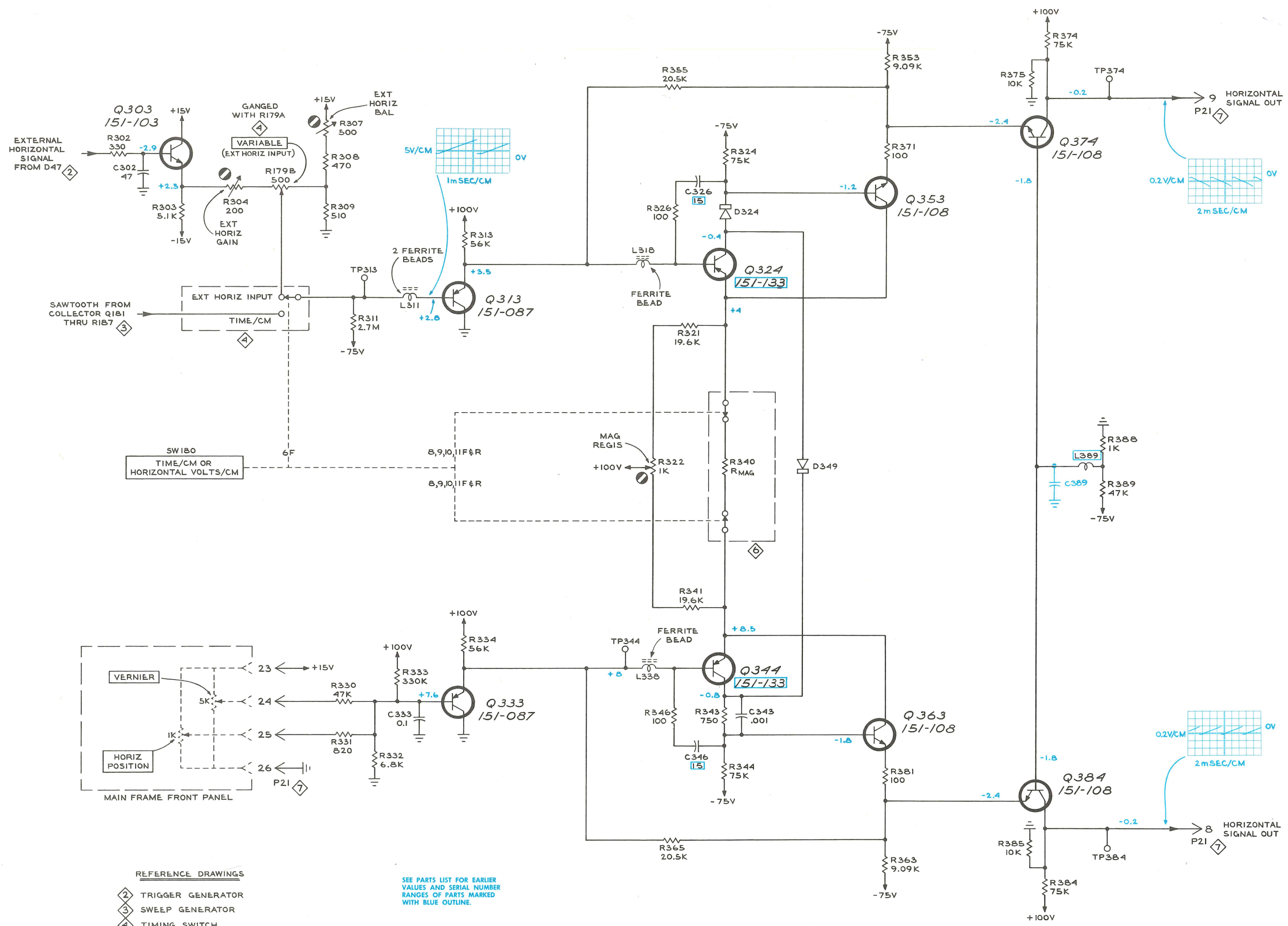

SWIBO  
TIME/CM OR  
HORIZONTAL VOLTS/CM

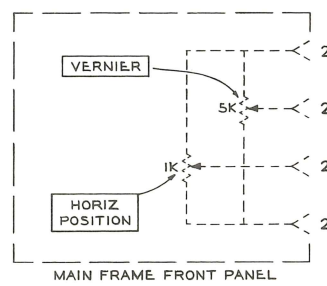

- REFERENCE DRAWINGS
- ② TRIGGER GENERATOR
  - ③ SWEEP GENERATOR
  - ④ TIMING SWITCH
  - ⑥ MAGNIFIER SWITCH
  - ⑦ INTERCONNECTING PLUG

SEE PARTS LIST FOR EARLIER  
VALUES AND SERIAL NUMBER  
RANGES OF PARTS MARKED  
WITH BLUE OUTLINE.

CMD  
566

TYPE IIB1 PLUG-IN

HORIZONTAL PREAMP ⑤

HORIZONTAL PREAMP



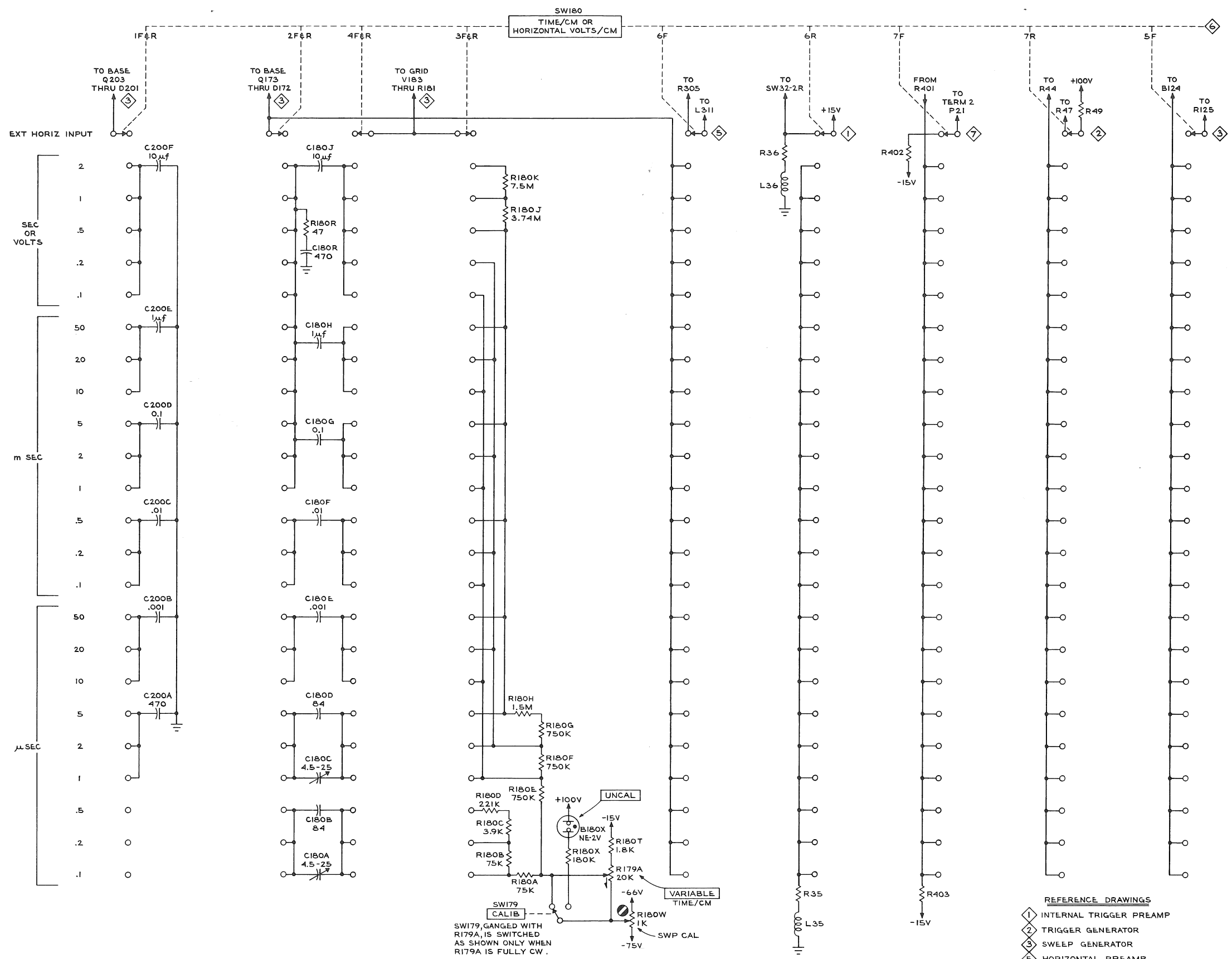

TYPE 11B1 PLUG-IN

A

- REFERENCE DRAWINGS
- ① INTERNAL TRIGGER PREAMP
  - ② TRIGGER GENERATOR
  - ③ SWEEP GENERATOR
  - ⑤ HORIZONTAL PREAMP
  - ⑦ INTERCONNECTING PLUG
  - ⑥ MAGNIFIER SWITCH

CMP 564

TIMING SWITCH ④

TIMING SWITCH



REFERENCE DRAWINGS

- ① INTERNAL TRIGGER PREAMP
- ② SWEEP GENERATOR
- ④ TIMING SWITCH
- ⑤ HORIZONTAL PREAMP

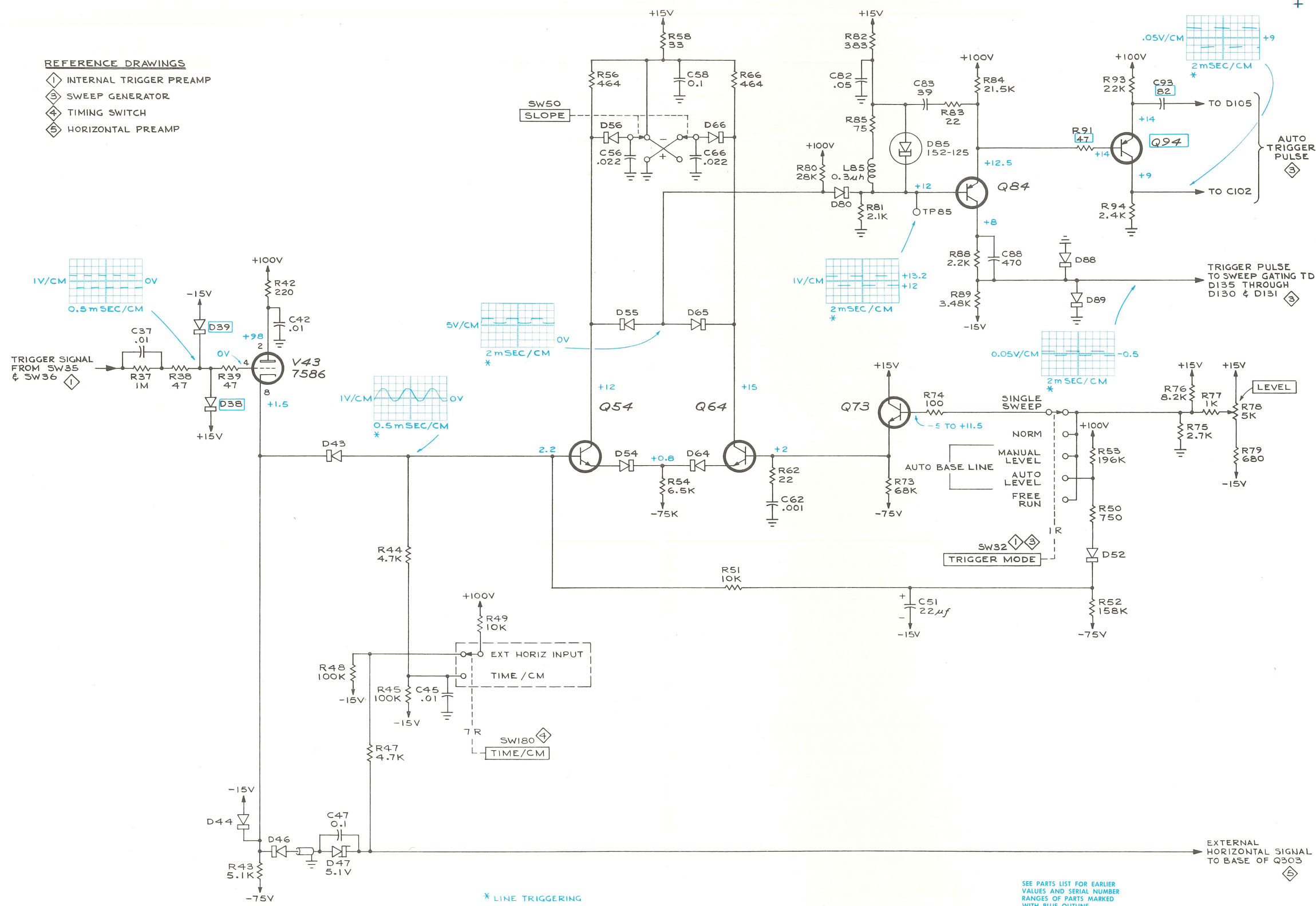

SEE PARTS LIST FOR EARLIER VALUES AND SERIAL NUMBER RANGES OF PARTS MARKED WITH BLUE OUTLINE.

MRH  
866

TYPE IIB1 PLUG-IN

c

TRIGGER GENERATOR ②

TRIGGER GENERATOR