

Instructions

Tektronix

013-0149-02

Standard Op Ampl Card

070-3729-00

Warning

The servicing instructions are for use by qualified personnel only. To avoid personal injury, do not perform any servicing unless you are qualified to do so. Refer to the Safety Summary prior to performing service.

First Edition: March 1982
Last Revised: January 1995

Copyright © Tektronix, Inc. 1982. All rights reserved.

Tektronix products are covered by U.S. and foreign patents, issued and pending. Information in this publication supercedes that in all previously published material. Specifications and price change privileges reserved.

Printed in the U.S.A.

Tektronix, Inc., P.O. Box 1000, Wilsonville, OR 97070-1000

TEKTRONIX and TEK are registered trademarks of Tektronix, Inc.

Instructions

STANDARD OP AMPL
CARD
013-0149-02

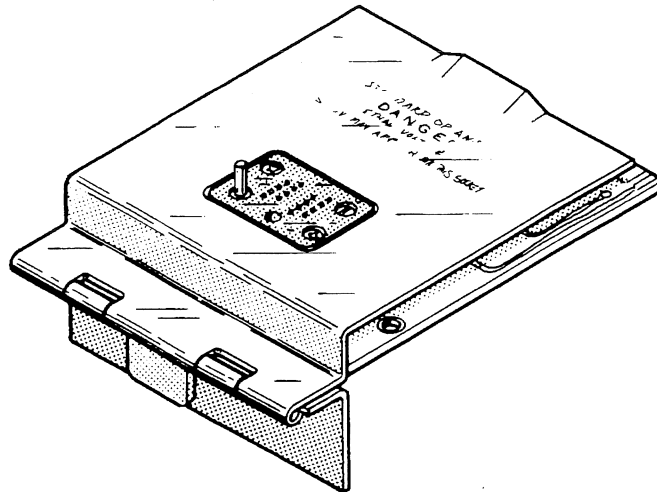

3729-01

SECTION 1

DESCRIPTION

The Standard Operational Amplifier Card is a test card for use with the TEKTRONIX 178 Linear Test Fixture and is supplied with the 178 Linear Test Fixture.

The following is a description of each of the features of the card illustrated by Fig. 1-1. The number in brackets, [], indicates the portion of the figure being considered.

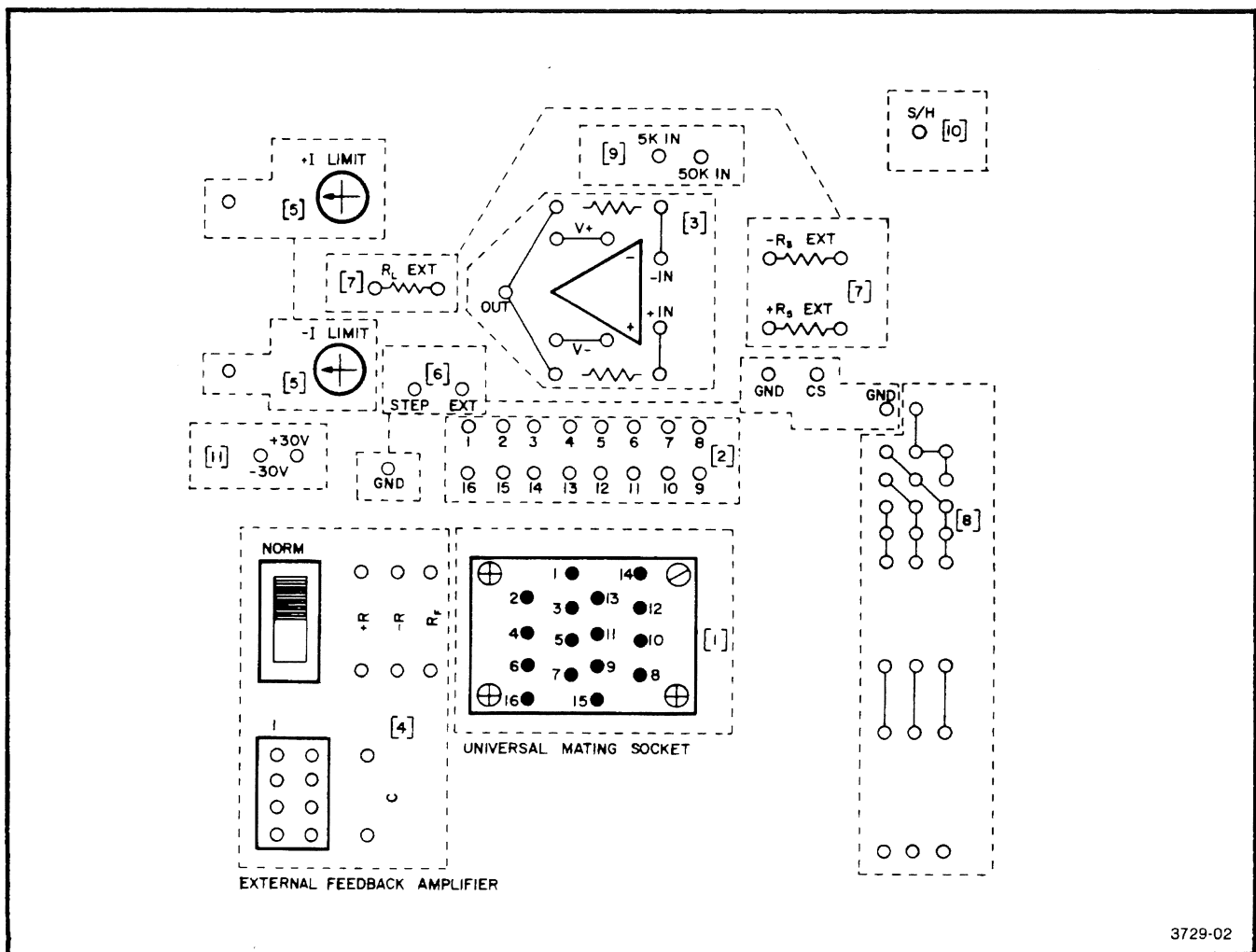

3729-02

Fig. 1-1. Standard Operational Amplifier.

Description—013-0149-02

[1] This is a universal mating connector into which several types of device under test (DUT) sockets may be plugged, using the Amphenol-Barnes adapter system. The adapter system accommodates most of the package configurations (TO-5, DIP, flat pack, etc.). Also available are ZERO INSERTION sockets for 14- and 16-lead dual-in-line packages from Textool Products, Inc., 1410 W. Pioneer Drive, Irving, Texas, 75061. (Order ZIP DIP ADAPTER, 216-2812-0-061 for 16-lead dual-in-line packages, and ZIP DIP ADAPTER, 214-2665-0-061 for 14-lead dual-in-line packages.)

[2] Connections from the adapter system are made via patch cords to the test circuits, [3].

[3] The 178 test circuits for the DUT are brought out to pin jacks within this area.

Each operational amplifier terminal is connected to pin jack. For example, the output is labeled OUT, and consists of three pin jacks. This allows for more than one patch cord or component to be connected to the OUT jack. Similarly, the pin jacks connecting to the DUT's differential inputs are labeled +IN and -IN. Each of the inputs consists of two pin jacks. The same for the DUT supplies, the positive supply labeled V+ and negative supply labeled V-. Each consists of two pin jacks.

[4] An external feedback amplifier (EXT FBA) is provided for additional closed loop gain, phase shift control, and other circuit applications when needed. The EXT FBA may be added to the closed loop test configuration by the switch shown in Fig. 1-2. This added gain can be useful for testing low gain amplifiers, for example, in a test function such as CMRR or PSRR, where the DUT's output voltage should be held at zero volts. In these functions, the EXT FBA maintains the DUT's output closer to zero volts than would be possible if the loop gain were provided by only a low-gain DUT. If the output of a low-gain DUT is not held close to zero volts, an error signal appears at the input.

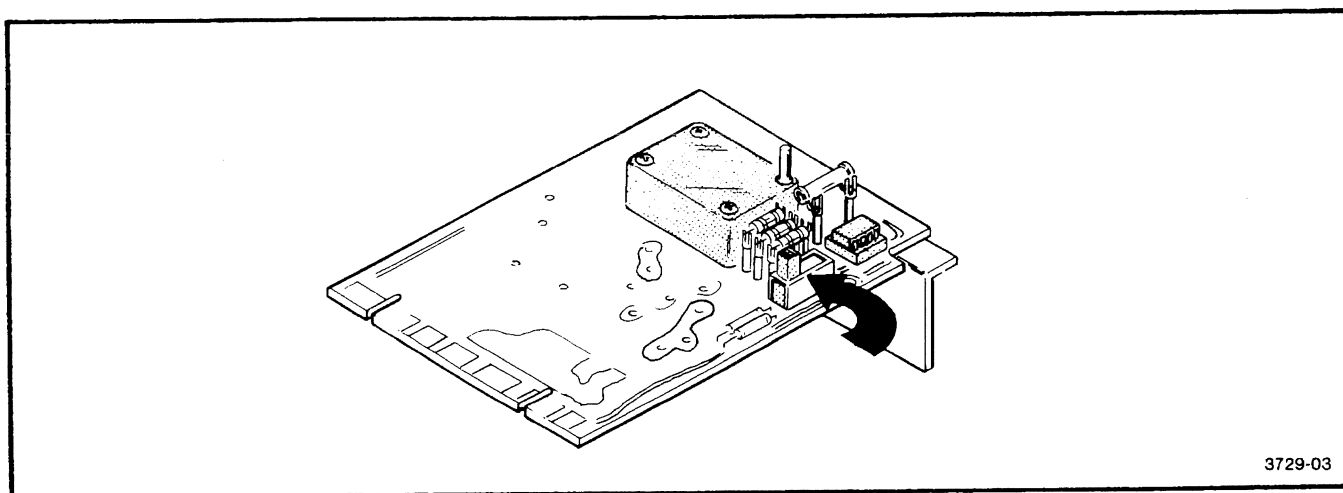

Fig. 1-2. External feedback amplifier and switch.

This error signal caused by low gain adds to the input signal during CMRR or PSRR and produces an erroneous measurement. With a high gain DUT, the error signal is directly reduced because a smaller signal is required at the input for a given output signal.

As a rule of thumb, this low DUT gain may cause significant measurement error when measuring CMRR and PSRR, if those parameters are 20 dB or more below the DUT gain. The EXT FBA has a gain of 40 dB, which is sufficient for most low gain, high CMRR-PSRR devices. This gain may be retailed if desired by the user.

For phase control, the LM301 is compensated with a 1000 pF capacitor for a first pole of <0.1 Hz, giving the EXT FBA a unity-gain bandwidth of ≤ 10 kHz.

The DUT will oscillate if a second pole in the system feedback loop occurs before system unity gain bandwidth is reached. Therefore, if the DUT has unity gain bandwidth much greater than the 178 gain bandwidth, the LM301 can be used to control the system gain bandwidth. To accomplish this system gain bandwidth control, increase the size of the LM301 compensating capacitor, C, on the Standard Operational Amplifier Card. If the DUT has compensating terminals, compensate the DUT for unity-gain bandwidth to stop oscillations, and do not use the EXT FBA.

With the EXT FBA switch in the NORM position, the EXT FBA may be used for other applications (e.g., EXT FBA can be patched into input, output, or power supply circuits to provide offset, power supply, buffer amplifier, common-mode amplifier, phase control, etc.).

[5] Two variable resistors, $-I$ Limit and $+I$ Limit, can be set to limit the DUT supply current; see 178 manual. These variable resistors may be removed and a 1/4 W resistor connected between the center solder pad under each variable resistor and the solder pad approximately 1/2 inch to the left of each of the variable resistors. Placing a wire between the solder pads permits the DUT supplies to provide a minimum of 150 mA for each supply. Inserting 50 Ω resistors will provide approximately 15 mA for each supply. The solder pads 1/2 inch to the left of the variable resistors are +40 V unregulated supply, upper solder pad, and -40 V unregulated supply, lower solder pad. The maximum available current is 175 mA, but the sum of the +40 V and +30 V supply currents should not exceed 185 mA (see [11]). The DUT supply current is considered as part of the 40 V supply. The same restrictions apply to the -40 V supply.

[6] Jacks STEP and CS provide access to the 577 Step Generator and Collector Supply. EXT connects to the 178 Ext Signal In jack (178 front panel). EXT is provided to allow an external power supply, sweep generator, DMM, or other test equipment to be connected into the DUT test circuits.

Kelvin sensing is provided for the collector sweep. Open the run on the back side of the board (see Fig. 1-3). Patch from the solder pad directly to the DUT terminal.

Kelvin sensing is provided for the return path. Open the run on the front side of the board (see Fig. 1-4). Patch from the solder pad shown, directly to the ground terminal of the DUT.

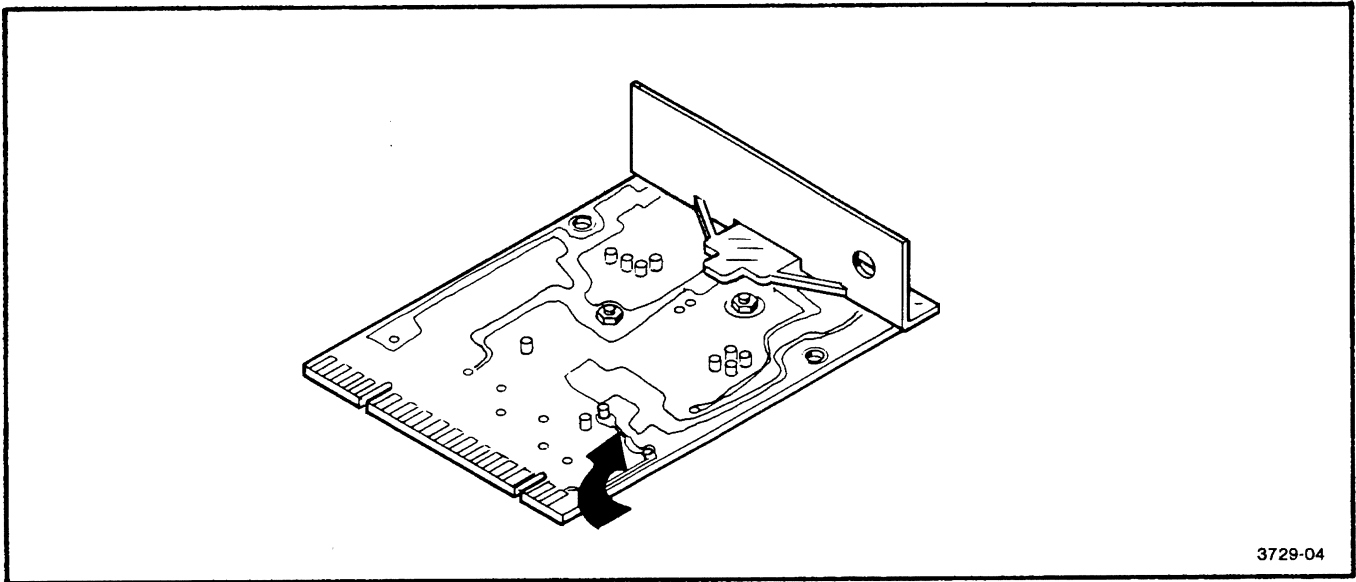

3729-04

Fig. 1-3. Breakpoint for collector sweep Kelvin sensing run. The solder pad is to the left on the run.

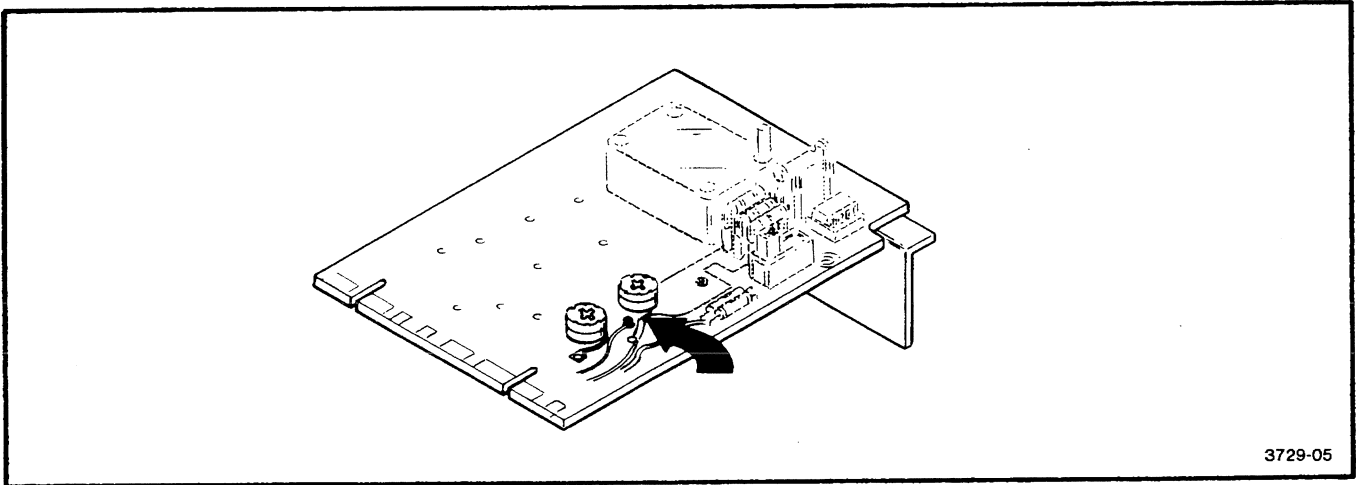

3729-05

Fig. 1-4. Breakpoint for Kelvin sensing return path. The solder pad is to the left on the run.

[7] R_L EXT provides the means to connect an external load resistor to the DUT output. The jack at the right end of R_L EXT is connected to the OUT jack when the Load Resistance switch on the 178 is in the Ext position. The left end of R_L EXT is grounded when the 178 Function switch is in the Offset V, Gain, or Collector Supply I position. The external load resistance is always in parallel with a 50 k Ω resistor.

$-R_s$ EXT and $+R_s$ EXT provide values of source resistance other than those selected by the 178 Source resistance switch (switch to Ext position). The right ends of pin jacks $+R_s$ EXT and $-R_s$ EXT are connected to the IN jacks (with the Source Resistance switch to the $50\ \Omega$ position). If the Source Resistance switch is in a position other than $50\ \Omega$, the resistance selected is between the right end of R_s EXT and the DUT terminal. In the EXT position of the Source Resistance switch, the left end of R_s EXT (pin jack) connects to the Input terminal.

[8] Sets of pin jacks are provided to patch additional components into the test circuits. Also, a hole in the front panel is provided to mount a variable resistor for making offset range and other tests.

[9] The $5\ \text{k}\Omega$ Input terminal is used to offset the output terminal voltage for devices that require the output at some voltage other than ground. The $5\ \text{k}\Omega$ input voltage must be of the opposite polarity and be one-tenth of the desired output voltage. Generally, the Step Generator can be used in the Offset voltage mode to provide this voltage.

The $50\ \text{k}\Omega$ input terminal is used the same as the $5\ \text{k}\Omega$ input. The offset voltage must be of the opposite polarity and equal to the desired voltage. The $50\ \text{k}\Omega$ Input is grounded when not used, to reduce noise in the 178. A run between the pin jack and ground must be opened to use this input. Resolder the run when this input is not being used. See Fig. 1-5 for location of solder pad and run.

[10] S/H output provides a direct output from the sample and hold in position (tests) 2 through 11 of the 178 Function switch. It is connected to the top of the +Input attenuator in all tests. In test 4, maximum current output is $1\ \text{mA}$. In all other tests, maximum current output is approximately $6\ \text{mA}$. The voltage compliance is approximately $24\ \text{V}$. Caution should be taken not to short the S/H output, as it may destroy the op-amp in the 178. The user should have a good understanding of the S/H circuit before attempting to use this circuit. See the circuit description and diagrams in the 178 manual.

[11] $+30\ \text{V}$ and $-30\ \text{V}$ regulated supplies are provided to operate additional circuitry if needed. Maximum available current is $50\ \text{mA}$ for each supply; but the sum of the $+30\ \text{V}$ and $+40\ \text{V}$ supply currents should not exceed $185\ \text{mA}$ and the $-30\ \text{V}$ and $-40\ \text{V}$ supply currents should not exceed $185\ \text{mA}$ (see [5]).

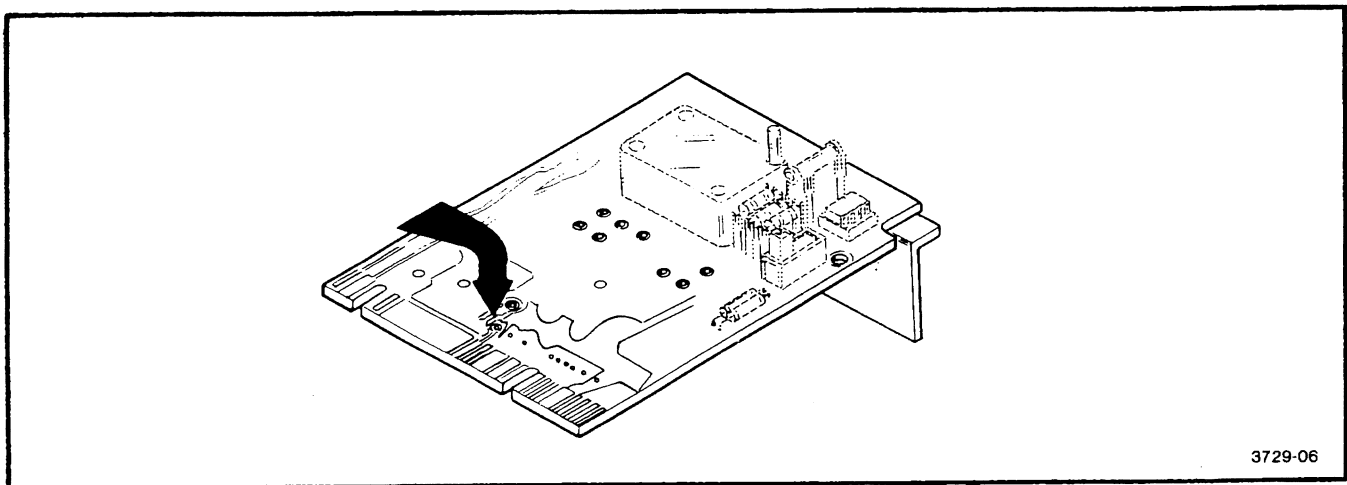

Fig. 1-5. Breakpoint for $50\ \text{k}\Omega$ Input run. The pin jack is below the breakpoint.

REPLACEABLE PARTS

PARTS ORDERING INFORMATION

Replacement parts are available from or through your local Tektronix, Inc. Field Office or representative.

Changes to Tektronix instruments are sometimes made to accommodate improved components as they become available, and to give you the benefit of the latest circuit improvements developed in our engineering department. It is therefore important, when ordering parts, to include the following information in your order: Part number, instrument type or number, serial number, and modification number if applicable.

If a part you have ordered has been replaced with a new or improved part, your local Tektronix, Inc. Field Office or representative will contact you concerning any change in part number.

Change information, if any, is located at the rear of this manual.

SPECIAL NOTES AND SYMBOLS

X000 Part first added at this serial number
 00X Part removed after this serial number

FIGURE AND INDEX NUMBERS

Items in this section are referenced by figure and index numbers to the illustrations.

INDENTATION SYSTEM

This mechanical parts list is indented to indicate item relationships. Following is an example of the indentation system used in the description column.

```

1 2 3 4 5      Name & Description
Assembly and/or Component
Attaching parts for Assembly and/or Component
    - - - * - - -
Detail Part of Assembly and/or Component
Attaching parts for Detail Part
    - - - * - - -
Parts of Detail Part
Attaching parts for Parts of Detail Part
    - - - * - - -
  
```

Attaching Parts always appear in the same indentation as the item it mounts, while the detail parts are indented to the right. Indented items are part of, and included with, the next higher indentation. The separation symbol - - - * - - - indicates the end of attaching parts.

Attaching parts must be purchased separately, unless otherwise specified.

ITEM NAME

In the Parts List, an Item Name is separated from the description by a colon (:). Because of space limitations, an Item Name may sometimes appear as incomplete. For further Item Name identification, the U.S. Federal Cataloging Handbook H6-1 can be utilized where possible.

ABBREVIATIONS

#	INCH	ELECTRN	ELECTRON	IN	INCH	SE	SINGLE END
ACTR	NUMBER SIZE	ELEC	ELECTRICAL	INCAND	INCANDESCENT	SECT	SECTION
ADPTR	ACTUATOR	ELCTLT	ELECTROLYTIC	INSUL	INSULATOR	SEMICOND	SEMICONDUCTOR
ALIGN	ADAPTER	ELEM	ELEMENT	INTL	INTERNAL	SHLD	SHIELD
AL	ALIGNMENT	EPL	ELECTRICAL PARTS LIST	LPHLDR	LAMPHOLDER	SHLDR	SHOULDERED
ASSEM	ALUMINUM	EQPT	EQUIPMENT	MACH	MACHINE	SKT	SOCKET
ASSEMB	ASSEMBLED	EXT	EXTERNAL	MECH	MECHANICAL	SL	SLIDE
ASSY	ASSEMBLY	FIL	FILLISTER HEAD	MTG	MOUNTING	SLFLKGG	SELF-LOCKING
ATTEN	ATTENUATOR	FLEX	FLEXIBLE	NIP	NIPPLE	SLVG	SLEEVE
AWG	AMERICAN WIRE GAGE	FLH	FLAT HEAD	NON WIRE	NOT WIRE WOUND	SPR	SPRING
BD	BOARD	FLTR	FILTER	OB	ORDER BY DESCRIPTION	SQ	SQUARE
BRKT	BRACKET	FR	FRAME or FRONT	OD	OUTSIDE DIAMETER	SST	STAINLESS STEEL
BR	BRASS	FSTNR	FASTENER	OVH	OVAL HEAD	STL	STEEL
BRZ	BRONZE	FT	FOOT	PH BRZ	PHOSPHOR BRONZE	SW	SWITCH
BSHG	BUSHING	FXD	FIXED	PL	PLAIN or PLATE	T	TUBE
CAB	CABINET	GSKT	GASKET	PLSTC	PLASTIC	TERM	TERMINAL
CAP	CAPACITOR	HDL	HANDLE	PN	PART NUMBER	THD	THREAD
CER	CERAMIC	HEX	HEXAGON	PNH	PAN HEAD	THK	THICK
CHAS	CHASSIS	HEX HD	HEXAGONAL HEAD	PWR	POWER	TNSN	TENSION
CKT	CIRCUIT	HEX SOC	HEXAGONAL SOCKET	RCP	RECEPTACLE	TPG	TAPPING
COMP	COMPOSITION	HLCPS	HELICAL COMPRESSION	RES	RESISTOR	TRH	TRUSS HEAD
CONN	CONNECTOR	HLEXT	HELICAL EXTENSION	RGD	RIGID	V	VOLTAGE
COV	COVER	HV	HIGH VOLTAGE	RLF	RELIEF	VAR	VARIABLE
CPLG	COUPLING	IC	INTEGRATED CIRCUIT	RTNR	RETAINER	W/	WITH
CRT	CATHODE RAY TUBE	ID	INSIDE DIAMETER	SCH	SOCKET HEAD	WSHR	WASHER
DEG	DEGREE	IDNT	IDENTIFICATION	SCOPE	OSCILLOSCOPE	XFMR	TRANSFORMER
DWR	DRAWER	IMPLR	IMPELLER	SCR	SCREW	XSTR	TRANSISTOR

CROSS INDEX—MFR. CODE NUMBER TO MANUFACTURER

Mfr. Code	Manufacturer	Address	City, State, Zip
01121	ALLEN-BRADLEY COMPANY	1201 2ND STREET SOUTH	MILWAUKEE, WI 53204
07707	USM CORP., USM FASTENER DIV.	510 RIVER RD.	SHELTON, CT 06484
10389	CHICAGO SWITCH, INC.	2035 WABANSIA AVE.	CHICAGO, IL 60647
11535	LORANGER MFG. CORP.	12-38 CLARK ST.	WARREN, PA 16365
14552	MICRO SEMICONDUCTOR CORP.	2830 E FAIRVIEW ST.	SANTA ANA, CA 92704
19613	TEXTTOOL PRODUCTS, INC.	1410 W PIONEER DRIVE	IRVING, TX 75061
27014	NATIONAL SEMICONDUCTOR CORP.	2900 SEMICONDUCTOR DR.	SANTA CLARA, CA 95051
56289	SPRAGUE ELECTRIC CO.	87 MARSHALL ST.	NORTH ADAMS, MA 01247
70318	ALLMETAL SCREW PRODUCTS CO., INC.	821 STEWART AVE.	GARDEN CITY, NY 11530
71279	CAMBRIDGE THERMIONIC CORP.	445 CONCORD AVE.	CAMBRIDGE, MA 02138
72982	ERIE TECHNOLOGICAL PRODUCTS, INC.	644 W. 12TH ST.	ERIE, PA 16512
73138	BECKMAN INSTRUMENTS, INC., HELIPOT DIV.	2500 HARBOR BLVD.	FULLERTON, CA 92634
73743	FISCHER SPECIAL MFG. CO.	446 MORGAN ST.	CINCINNATI, OH 45206
73803	TEXAS INSTRUMENTS, INC., METALLURGICAL MATERIALS DIV.	34 FOREST STREET	ATTLEBORO, MA 02703
80009	TEKTRONIX, INC.	P O BOX 500	BEAVERTON, OR 97077
83385	CENTRAL SCREW CO.	2530 CRESCENT DR.	BROADVIEW, IL 60153
88245	LITTON SYSTEMS, INC., USECO DIV.	13536 SATICOY ST.	VAN NUYS, CA 91409

Replaceable Electrical Parts—013-0149-02

Ckt No.	Tektronix Part No.	Serial/Model No. Eff Dscont	Name & Description	Mfr Code	Mfr Part Number
	670-2567-01		CKT BOARD ASSY:STANDARD OP AMP	80009	670-2567-01
C15	281-0536-00		CAP., FXD, CER DI:1000PF, 10%, 500V	72982	301000 X 5P0102K
C23	283-0110-00		CAP., FXD, CER DI:0.005UF, +80-20%, 150V	56289	19C242B
C25	283-0110-00		CAP., FXD, CER DI:0.005UF, +80-20%, 150V	56289	19C242B
CR14	152-0243-00		SEMICONV DEVICE:ZENER, 0.4W, 15V, 5%	14552	TD3810983
CR18	152-0243-00		SEMICONV DEVICE:ZENER, 0.4W, 15V, 5%	14552	TD3810983
R10	311-1568-00		RES., VAR, NONWIR:50 OHM, 20%, 0.50W	73138	91-90-0
R14	315-0104-00		RES., FXD, CMPSN:100K OHM, 5%, 0.25W	01121	CB1045
R15	315-0102-00		RES., FXD, CMPSN:1K OHM, 5%, 0.25W	01121	CB1025
R16	315-0102-00		RES., FXD, CMPSN:1K OHM, 5%, 0.25W	01121	CB1025
R20	311-1568-00		RES., VAR, NONWIR:50 OHM, 20%, 0.50W	73138	91-90-0
S30	260-1641-00		SWITCH, SLIDE:DPDT, 0.5A, 125VAC	10389	23-021-114
U16	156-0105-00		MICROCIRCUIT, LI:OPERATIONAL AMPLIFIER	27014	LM301AN

Replaceable Mechanical Parts—013-0149-02

EXPLODED VIEW

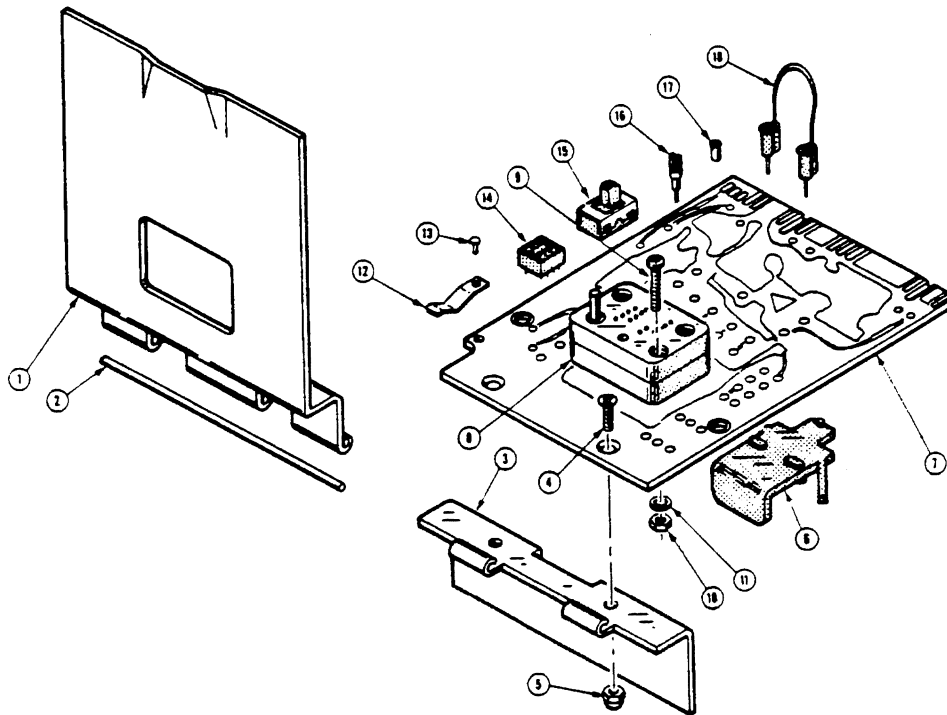
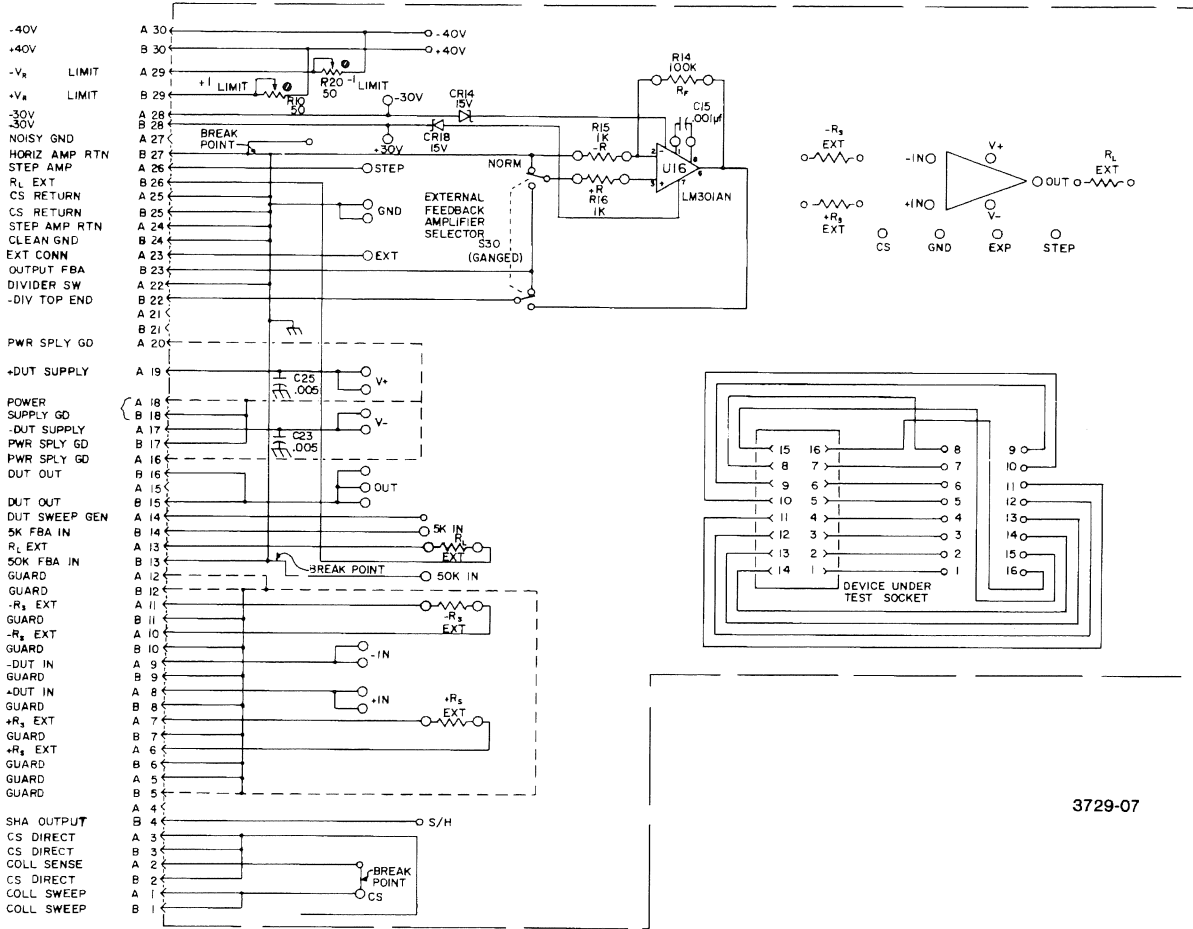

Fig. & Index No.	Tektronix Part No.	Serial/Model No. Eff	Dscont	Qty	1	2	3	4	5	Name & Description	Mfr Code	Mfr Part Number
1-	013-0149-02			1						ADAPTER, CKT BD: STANDARD OPERATIONAL AMPL	80009	013-0149-02
-1	200-1513-06			1						COVER, CKT BOARD: ALUM (ATTACHING PARTS)	80009	200-1513-06
-2	214-1901-00			1						PIN, HINGE: 0.072 DIA X 3.3 INCH L, SST - - - * - - -	80009	214-1901-00
-3	214-1883-00			1						HNG, CKT BD VOC: ALUM (ATTACHING PARTS)	80009	214-1883-00
-4	211-0101-00			2						SCREW, MACHINE: 4-40 X 0.25, 100 DEG, FLH STL	83385	OBD
-5	220-0601-00			2						NUT, PLAIN, CAP.: 4-40 X 0.25 INCH HEX, BRS - - - * - - -	73743	93261-03
-6	367-0185-00			1						PULL, CKT CARD: GRAY PLASTIC	80009	367-0185-00
-7	-----			1						CKT BOARD ASSY: STANDARD OP AMP (SEE REPL)		
-8	131-1373-01			1						CONN, RCPT, ELEC: CKT BD MT, 16 CONT (ATTACHING PARTS)	80009	131-1373-01
-9	211-0126-00			2						SCREW, MACHINE: 4-40 X 0.625, FLH, SST	70318	OBD
-10	210-0406-00			2						NUT, PLAIN, HEX.: 4-40 X 0.188 INCH, BRS	73743	12161-50
-11	210-0054-00			2						WASHER, LOCK: SPLIT, 0.118 ID X 0.212" OD STL - - - * - - -	83385	OBD
-12	214-1974-00			1						SPRING, GROUND: 0.625 INCH LONG (ATTACHING PARTS)	80009	214-1974-00
-13	210-0702-00			1						EYELET, METALLIC: 0.047 OD X 0.125 INCH LONG - - - * - - -	07707	S6127
-14	136-0514-00			1						SKT, PL-IN ELEC: MICROCIRCUIT, 8 DIP	73803	CS9002-8
-15	-----			1						(SEE S30 REPL)		
-16	131-1497-00			12						CONTACT, ELEC: 0.04 DIA PIN 1 END	88245	15409
-17	136-0388-00			67						SOCKET, PIN TERM: U/W 0.04 DIA PIN	71279	450-3704-01-0300
-18	012-0200-00			10						LEAD, TEST: 2.0 L RED, PIN JACK TO PIN JACK	80009	012-0200-00

Replaceable Mechanical Parts—013-0149-02

Fig. & Index No.	Tektronix Part No.	Serial/Model No. Eff Dscont	Qty	1	2	3	4	5	Name & Description	Mfr Code	Mfr Part Number
STANDARD ACCESSORIES											
	070-3729-00		1						. SHEET, TECHNICAL: INSTR, 013-0149-02 CB ADAPT	80009	070-3729-00
OPTIONAL ACCESSORIES											
	012-0200-00		1						LEAD, TEST: 2.0 L RED, PIN JACK TO PIN JACK	80009	012-0200-00
	012-0310-00		1						LEAD, TEST: 4.0 L W/0.187L X 0.04 OD PIN EA END	80009	012-0310-00
	136-0441-00		1						SOCKET, PLUG-IN: XSTR, 10 LEAD TO TO-5	11535	LMC2767101-FA09/
	136-0442-00		1						SOCKET, PLUG-IN: MICROCIRCUIT, 16 CONTACT	11535	LMC2748161-FA05/
	136-0443-00		1						SOCKET, PLUG-IN: MICROCIRCUIT, 14 CONTACT	19613-	214-2665-00-0602
	136-0444-00		1						SOCKET, PLUG-IN: XSTR, 10 LEAD TO TO-5	11535	LMC-2767-810FA07

SECTION 3



TO 178 LINER IC TEST FIXTURE

3729-07

CIRCUIT BOARD LAYOUT

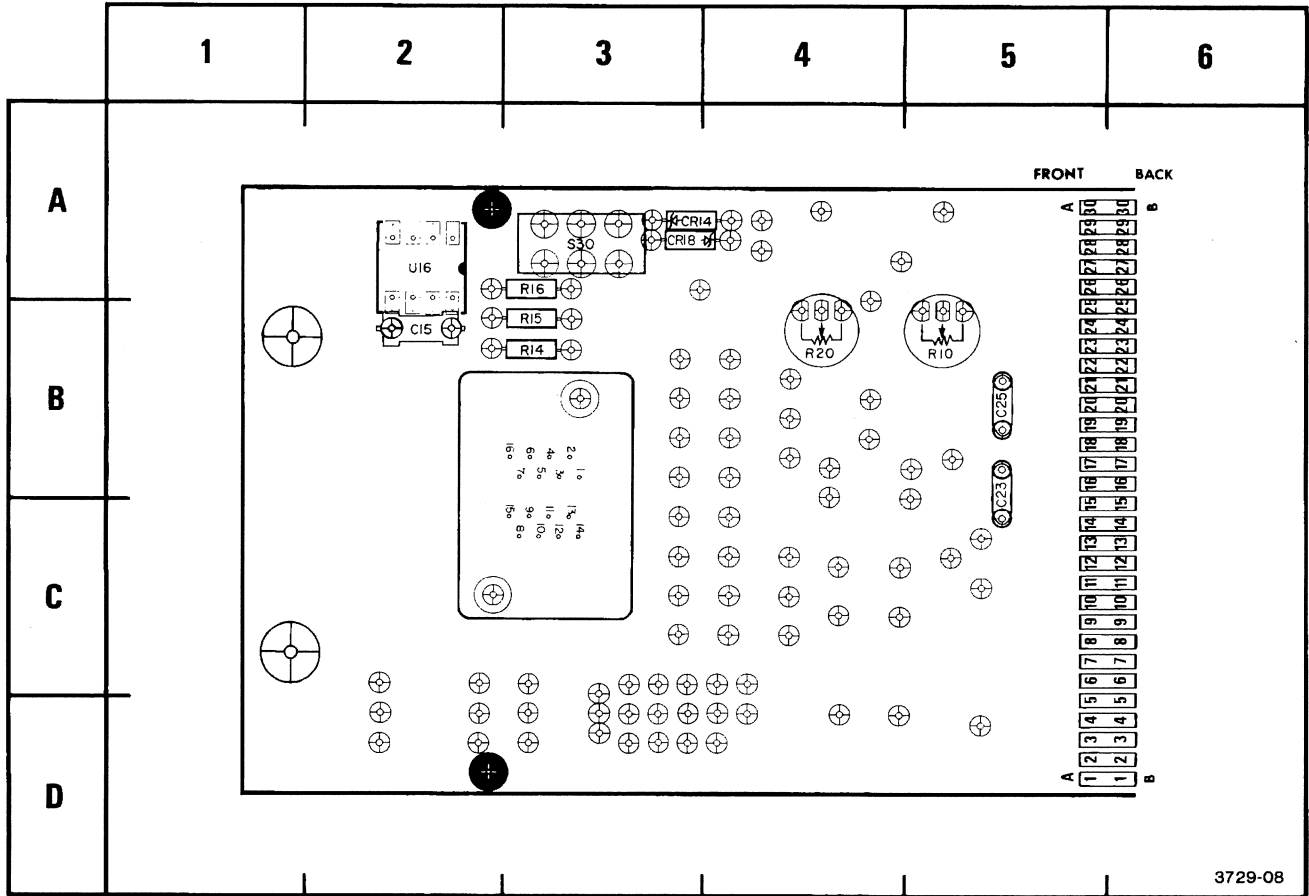

3729-08

CKT NO	GRID LOC
C15	2B
C23	5C
C25	5B
CR14	3A
CR18	3A
R10	5B
R14	3B
R15	3B
R16	3A
R20	4B
S30	3A
U16	2A