

FACTORY CALIBRATION PROCEDURE

CONTENTS:

General	1
Equipment required	2
Factory test limits	1A, 1B, 1C
Factory calibration procedure	2A, 2B, 5C

INTRODUCTION:

This is the guide for calibrating brand-new instruments, it therefore, calls out many procedures and adjustments that are rarely required for subsequent recalibration. *This procedure is company confidential.* In this procedure, all front panel control labels or Tektronix equipment names are in capital letters (VOLTS/DIV, etc.) internal adjustment labels are capitalized only (Gain Adj, etc.).

Tek form number:

0-403

November 1966

For all serial numbers.



491

FACTORY TEST LIMITS:

We initially calibrate the instrument to Factory Test Limits. These limits are often more stringent than advertised performance requirements. This helps insure that the instrument will meet advertised requirements after shipment, allows for inaccuracies of test equipment used, and may allow for changes in environmental conditions.

QUALIFICATION:

Factory test limits are qualified by the conditions specified in the main body of the calibration procedure. The numbers and letters to the left of the limits correspond to the factory calibration procedure steps where the check or adjustment is made. Instruments may not meet factory test limits if calibration or check-out methods and test equipment differ substantially from those in this procedure.

ABBREVIATIONS:

Abbreviations in this procedure will be found listed in TEKTRONIX STANDARD A-100.

CHANGE INFORMATION:

This procedure has been prepared by Product Manufacturing Staff Engineering. For information on changes that have been made to this procedure, to make suggestions for changing this procedure, or to order additional copies: please contact PMSE, 47-261. (DC)



PMSE

COMPANY CONFIDENTIAL

EQUIPMENT REQUIRED:

The following equipment is necessary to complete this procedure:

- A Indicates equipment required for honeycomb calibration.
- B Indicates equipment required for phase lock calibration.
- C Indicates equipment required for complete TYPE 491 calibration.

a. TEKTRONIX Instruments

- A 1 TYPE 547 OSCILLOSCOPE (plug-in scope)
- ABC 1 TYPE 547 OSCILLOSCOPE (test scope)
- ABC 1 TYPE 1A1 DUAL TRACE PLUG-IN UNIT
- C 1 TYPE D PLUG-IN UNIT
- * C 1 TYPE 184 TIME MARK GENERATOR
- A 1 TYPE 1L30 SPECTRUM ANALYZER PLUG-IN UNIT (calibrated test plug-in)
- B 1 TYPE 491 (calibrated test instrument)
- C 1 TYPE 76TU Line Voltage Control Unit
- A 2 TYPE P6040 PROBES
- ABC 1 TYPE P6006 PASSIVE PROBE
- C 1 TYPE P6011 1X PASSIVE PROBE

b. Test Fixtures and Accessories

- ABC 2 50 Ω cables, BNC (012-0059-00)
- C 1 BNC T connector (103-0030-00)
- A C 1 N male to BNC female adapter (103-0045-00)
- ABC 2 GR to BNC male adapters (017-0064-00)
- A C 1 Clip lead adapter, BNC (013-0076-00)
- A C 1 50 Ω termination (011-0049-00)
- A 1 11" lossy cable (175-0364-00)
- B 1 2" lossy cable (175-0308-00)
- A 1 1L20-1L30 square pin connector extension cable
(see PMPE Dwg #1438-A)
- B 1 TYPE 491 phase lock test jig (see PMPE Dwg #1513-A)
- C 1 600 Ω load cable for TO RECORDER output (see PMPE Dwg #1439-A)
- C 1 Harmonic Modulator (067-0518-00)
- C 1 STANDARD AMPLITUDE CALIBRATOR (SAC) (067-0502-00)
- A 1 Flexible extension (012-0038-00)

c. Other Equipment

- * ABC 1 20,000 Ω /V Multimeter (Simpson 262 or equivalent)
(067-0045-00)
- * A C 1 MC (Measurements Corporation) Model 111B Crystal Calibrator
- * A C 1 Kay Model 121C Multi-sweep generator
- * ABC 1 HP (Hewlett-Packard) 355C UHF Attenuator 0-12dB in 1dB steps
- * ABC 1 HP (Hewlett-Packard) 355D UHF Attenuator 0-120dB in 10dB steps
- * ABC 1 HP (Hewlett-Packard) 241A Oscillator, 10 Hz to 1 MHz
- * ABC 1 HP (Hewlett-Packard) 608D UHF signal generator, 10 MHz
to 480 MHz
- * C 1 HP (Hewlett-Packard) 612A UHF signal generator, 450 MHz
to 1230 MHz
- * C 1 HP (Hewlett-Packard) 8614A UHF signal generator, 800 MHz
to 2400 MHz
- * C 1 HP (Hewlett-Packard) 8616A UHF signal generator, 1800 MHz
to 4500 MHz

EQUIPMENT REQUIRED: (c. cont'd)

- * C 1 Polarad 1107 microwave signal generator, 3.8 GHz to 8.2 GHz
- * C 1 Polarad 1108 microwave signal generator, 6.95 GHz to 11.0 GHz
- * C 1 HP (Hewlett-Packard) 626A SHF signal generator, 10.0 GHz to 15.5 GHz
- * C 1 HP (Hewlett-Packard) 628A SHF signal generator, 15.0 GHz to 21.0 GHz
- * C 1 HP (Hewlett-Packard) 938 Frequency doubler set, 18.0 GHz to 26.5 GHz
- * C 1 HP (Hewlett-Packard) 940 Frequency doubler set, 26.5 GHz to 40.0 GHz
- C 1 HP (Hewlett-Packard) X281 wave-guide to coax adapter
- C 2 HP (Hewlett-Packard) NP292A wave-guide to coax adapter
- C 2 HP (Hewlett-Packard) MX292B wave-guide to coax adapter
- C 2 HP (Hewlett-Packard) MP292B wave-guide to coax adapter
- C 2 HP (Hewlett-Packard) NK292A wave-guide to coax adapter
- C 3 HP (Hewlett-Packard) 11503A Flexible wave-guide
- C 3 HP (Hewlett-Packard) 11504A flexible wave-guide

* This equipment must be traceable to NBS for instrument certification.

Substitute test equipment may be used. The Plant Staff Engineer must approve any substitutions. All equipment listed must perform within its manufacturer's specifications, unless otherwise stated.

FACTORY TEST LIMITS

A. HONEYCOMB SUBASSEMBLY

QUALIFICATION

Factory test limits are qualified by the conditions specified in the main body of the calibration procedure. The numbers and letters to the left of the limits correspond to the factory calibration procedure steps where the check or adjustment is made. Instruments may not meet factory test limits if calibration or checkout methods and test equipment differ substantially from those in this procedure.

1. PRELIMINARY INSPECTION
2. PRESET CONTROLS
3. RESISTANCE CHECK
4. SWEEPER
5. 70 MHz OSCILLATOR
6. IF RESPONSE
7. SWEEPER LINEARITY
 - b. Adjust sweeper linearity $\pm 3\%$, max
8. IF CENTER FREQ CONTROL RANGE ± 25 MHz, min
9. DISPERSION RANGE kHz/cm
10. VARIABLE RESOLUTION AMPLIFIER

11. 75 MHz and 65 MHz TRAPS
12. IF ATTENUATOR
 - b. Check IF ATTENUATOR:
51dB in 1dB steps ± 0.1 dB/dB
13. IF SENSITIVITY
 - b. Check IF Sensitivity: -110 to -115dBm
14. 150-250 MHz BANDPASS FILTER
 - c. Adjust 150-250 MHz filter response:
Insertion loss: approx 0.5dB;
flatness ≤ 0.4 dB P to P; less than -1.5dB at 150-250 MHz
Points: -10dB at 140-270 MHz points (-6dB acceptable)
15. COMBINED FILTERS
 - c. Check overall system flatness ± 1.5 dB from 870 MHz to 2050 MHz

THE END

A. HONEYCOMB SUBASSEMBLY

1. PRELIMINARY INSPECTION

Check for unsoldered joints, rosin joints, proper lead dress and long wire ends. Check for reversed diodes, shorted or open transformers and orientation of transistors in sockets. Correct all defects found.

2. PRESET CONTROLSTYPE 1L30

SW 201 (rear panel)	100V SAWTOOTH
GAIN	ccw
VIDEO FILTER	OFF
VERTICAL DISPLAY	LIN
DISPERSION RANGE	MHz/CM
DISPERSION	10
RESOLUTION	COUPLED
IF CENTER FREQ	0-0-0
FINE	midr
VERTICAL POSITION	midr

3. RESISTANCE CHECK

Set multimeter to $\Omega \times 10k$ and check resistance between honeycomb connector strip pins and chassis as in the following table:

<u>Terminal</u>	<u>Approximate Reading</u>	<u>Approximate Reading (Reverse Meter Polarity)</u>
A	0 Ω	0 Ω
B	inf	inf
C	inf	inf
D	inf	inf
E	4k	4k
F	2.7k	2.7k
G	inf	3k
H	inf	5k
U	inf	3k
J	30k	30k
K	20k	20k
L	inf	4k
M	12k	12k
N	inf	3k
O	inf	3k
P	100k	100k

4. SWEEPER*a. Setup*

Plug the TYPE 1A1 into the test scope. Set the test scope TIME/CM to 10mSEC and TRIGGERING to EXT AC. Set the plug-in scope TRIGGERING to INT AC. Connect the test scope +GATE to plug-in scope TRIGGER INPUT.

Connect the Honeycomb chassis to test plug-in with a square-pin extension cable. Connect the test plug-in to plug-in scope with a flexible extension. Turn test scope and plug-in scope POWER ON.

b. Check and adjust sweeper

Adjust the RF AMPL, R290 for approximately -0.9VDC at pin P of the square-pin connector strip. Connect a 10X probe from pin M of the square pin connector strip to TYPE 1A1 PLUG-IN INPUT. Check for a waveform similar to Fig. 1A.

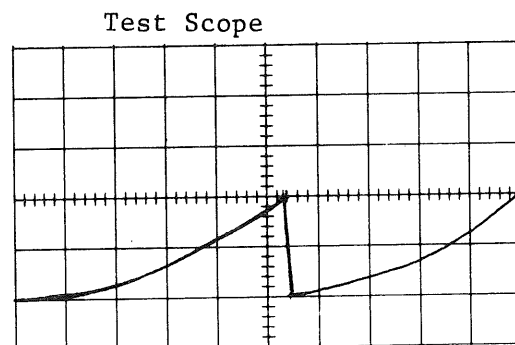

Fig. 1A

5. 70 MHz OSCILLATOR*a. Setup*

Connect the 150-250 MHz bandpass filter to the IF amplifiers and the IF attenuator. J109 to J120, J147 to J151, J148 to J363, and J188 to J401. Connect the HP608D RF OUTPUT - N to BNC adapter -- 50Ω cable -- BNC to GR adapter -- P6040 probe -- to the input of the 150-250 MHz bandpass filter, J100. Set the HP608D FREQUENCY to 200MC. Connect a P6006 probe from INPUT A of the TYPE 1A1 to the collector of Q450 (narrow band amplifier).

b. Adjust 70 MHz oscillator (L444)

Adjust L444 to a point where the oscillator locks in with the 70 MHz crystal.

b. The crystal mode will not necessarily produce the largest amplitude signal on the test scope CRT, but it will be the most stable.

6. IF RESPONSE*a. Setup*

Set TYPE 1A1 VOLTS/CM to .5, AC coupled. Connect a 10X probe from the output of the Variable Resolution Amplifier (coax end of C534) to TYPE 1A1 INPUT. Set the test

6a. (cont'd)

scope TIME/CM to .5mSEC. Set the plug-in scope TIME/CM to .2mSEC. Set test plug-in DISPERSION RANGE to MHz/CM, DISPERSION to .2 and RESOLUTION full cw.

b. *Adjust IF amplifier response*

Make adjustments as in the following table:

b. Use the 200 MHz IF feed through signal to make IF amplifier response adjustments.

<u>ckt symbol</u>	<u>location</u>	<u>conditions</u>	<u>adjust for</u>
L144	wide band amplifier	20dB ATTEN ON GAIN full cw	max signal
C425	narrow band amplifier	20dB ATTEN ON GAIN full cw	max noise ampl
C435			
T454	narrow band amplifier	20dB ATTEN ON GAIN full cw	max signal
T464			
L444	narrow band amplifier	set to a stable mode	max signal

Repeat the above adjustments as they interact.

7. SWEEPER LINEARITY

a. *Setup*

Connect TYPE 184 output -- 50Ω cable -- BNC to GR adapter -- P6040 probe -- J100. Set TYPE 184 for .1μs (10 MHz) markers.

b. *Adjust sweeper linearity:
Non-linearity ±3%, max*

Set test plug-in DISPERSION CAL for 1 mark/cm. Adjust C358 (sweeper circuit) for best linearity over the center 8cm of the display area. Monitor pin M and recheck sawtooth.

8. IF CENTER FREQ CONTROL RANGE ±25 MHz, min

Set test plug-in DISPERSION control to 5 MHz/cm, COUPLED RESOLUTION. Turn IF CENTER FREQ fully ccw. Turn IF CENTER FREQ slowly cw while counting the time marks that pass under the center graticule line of the plug-in scope.

Adjust IF CF RANGE (R290) for at least 5 time marks from full ccw to full cw on the IF CENTER FREQ dial.

12. If R290 is adjusted it will be necessary to repeat step 7.

9. DISPERSION RANGE kHz/cm

a. Setup

HP608D RF OUTPUT -- N to BNC adapter -- 50 Ω cable -- BNC to GR adapter P6040 probe -- J100. Set HP608D FREQUENCY to 200MC. Set the test plug-in DISPERSION RANGE to kHz/cm and DISPERSION to 500.

Preset C384 three turns from completely in and C385 four and one-half turns from completely in. (Sweeper Circuit)

b. Adjust center frequency to 200 MHz

Locate the center frequency by changing the HP608D FREQUENCY. Adjust C384 and C385 to center 200 MHz on the plug-in scope graticule.

Disconnect the 50 Ω cable from the BNC adapter at HP608D RF Output.

b. Move C384 and C395 in together to lower the frequency or out to raise the frequency. Spurious frequencies will appear as spikes. The 200 MHz center frequency will be larger in amplitude and wider at the base line. (See Fig. 2A and 3A.)

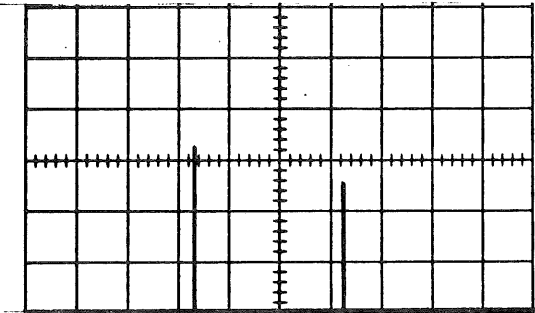

Fig. 2A spurious responses

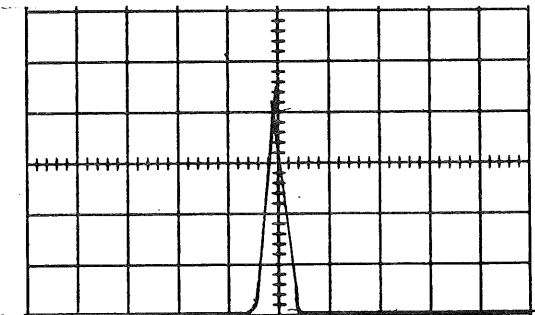

Fig. 3A 200 MHz center frequency

c. Adjust kHz/cm

Connect the 50 Ω cable to the TYPE 184 MARKER OUTPUT. Set the TYPE 184 MARKER SELECTOR to 1 μ s. Adjust C384 and C385 for 500 kHz/cm (1 mark/2cm). Check linearity over the center 8cm of the plug-in scope graticule. Disconnect the 50 Ω cable from the TYPE 184 and check center frequency adjustment as in the previous step.

c. Rotate C384 and C385 in opposite directions to adjust dispersion.

10. VARIABLE RESOLUTION AMPLIFIER*a. Setup*

Connect TYPE 184 -- BNC to GR adapter -- P6040 cable -- J501 of the Honeycomb Subassembly. Press TYPE 184 10nS MARKER SELECTOR.

Connect the plug-in scope SWEEP A to test scope TRIGGER INPUT. Set both TIME/CM switches to 20mSEC. Set the test scope and plug-in scope TRIGGERING SOURCE to EXT and plug-in scope TRIGGERING LEVEL for a free running sweep. Connect a 10X probe from pin B of the honeycomb connector strip to test scope plug-in input.

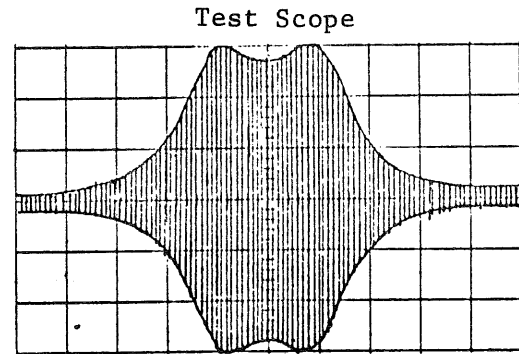

Fig. 4A

b. Adjust Variable Resolution amplifier response: symmetrical waveform

Adjust C504 and C508 for the most symmetrical waveform on the test scope (see Fig. 4A).

11. 75 MHz and 65 MHz TRAPS*a. Setup*

Set HP608D VHF CENTER FREQ to 75MC. Connect HP608D output -- N to BNC adapter -- 50Ω cable -- BNC to GR adapter -- P6040 probe -- J120.

b. Adjust 75 MHz trap

Spread wires of L124 (wide band amplifier) for minimum deflection on test scope and plug-in scope CRT's.

c. Adjust 65 MHz trap

Change HP608D VHF CENTER FREQ to 65MC. Adjust L147 for minimum deflection on test scope and plug-in scope CRT's.

12. IF ATTENUATOR

a. Setup

Remove the HP608D signal connection from J120 and reconnect the cable from J109 to J120. Connect HP608D -- HP355C -- HP355D -- 50Ω cable -- 50Ω X10 attenuator -- test plug-in RF INPUT. Set the HP608D ATTEN to -30dBm and frequency to 200 MHz. Set the test plug-in DISPERSION RANGE to kHz/cm and GAIN and DISPERSION for a 6cm display.

b. Check IF ATTENUATOR accuracy: 51dB in 1dB steps ±0.1 dB/dB

Progressively switch in each IF ATTENUATOR and switch out the corresponding HP355C or HP355D attenuator. Compare the amplitude in each position to the 6cm reference as in the following table:

<u>IF ATTENUATOR</u>	<u>Tolerance</u>
1dB	0.9-1.1dB
2dB	1.8-2.2dB
4dB	3.6-4.4dB
8dB	7.2-8.8dB
16dB	14.4-17.6dB
20dB	18.0-22.0dB

13. IF SENSITIVITY

a. Setup

Connect HP608D RF OUT -- TYPE N to BNC adapter -- 50Ω cable -- BNC to GR adapter -- P6040 -- J100. Set HP608D UHF CENTER FREQ to 200MC.

b. Check IF Sensitivity -110 to -115dBm

Adjust the test plug-in GAIN for a display of 1cm of noise. Turn the HP608D ATTEN ccw until the signal amplitude is twice the noise amplitude, (see Fig. 5A). Read IF sensitivity from the HP608D ATTEN dial.

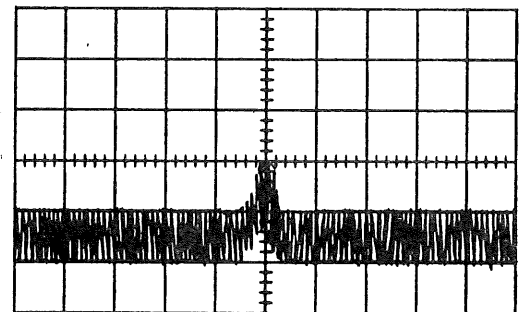
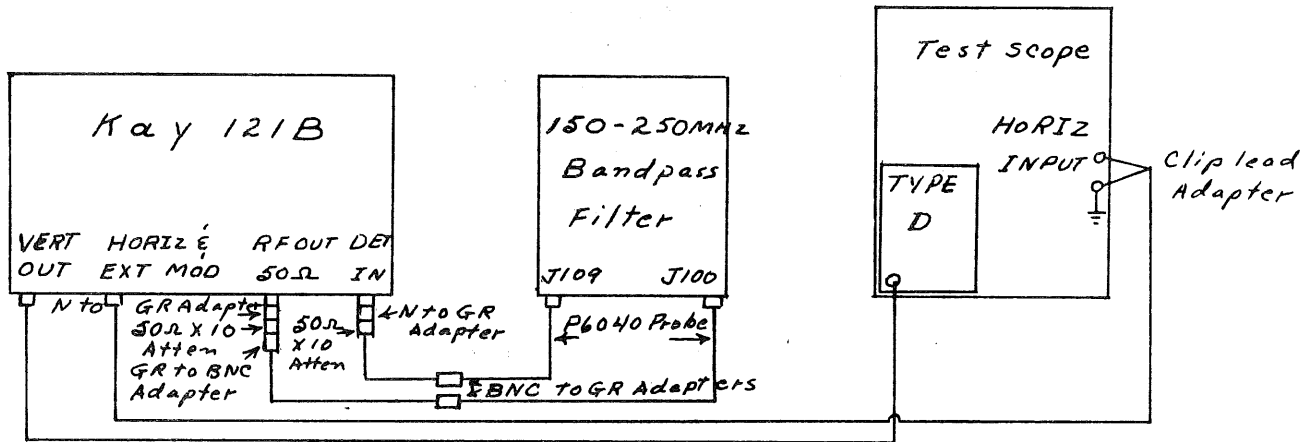

Fig 5A

14. 150-250 MHz BANDPASS FILTER

a. Setup

Make connections as shown below:



Set KAY 121B VHF CENTER FREQ control to display the 100MC markers; second harmonic at the center of the test scope CRT. Connect KAY 121B RF OUT 50Ω and DET IN leads together and set VAR RF LEVEL ADJ for 6cm of vertical deflection. Preset C101, C102, C104, C106, C107 and C108 to minimum capacitance. Reconnect KAY 121B RF OUT 50Ω and DET IN leads to J100 and J109 on the 150-250 MHz bandpass filter chassis.

b. Set 150-250 MHz bandpass filter center frequency (L105)

Set center frequency to 185-190 MHz by adjusting the length of L105.

c. Adjust 150-250 MHz filter response:
 Insertion loss: approx 0.5dB;
 Flatness 0.4dB P to P

c. Less than -1.5dB at 150 MHz-250 MHz points; -6 to -10dB at 140 MHz-270 MHz points.

Adjust C101, C102, C104, C106, C107 and C108 for a display similar to Fig. 6A.

It will be necessary to switch the KAY 121B HARMONIC MARKER back and forth between 100MC and 10MC to keep track of the center frequency relative to the filter response.

d. Check 280 MHz filter response

Connect KAY 121B RF OUT 50Ω to J80 and DET IN to J94.

Check for ≈ 0.5dB insertion loss, smooth rolloff starting at 250 MHz and ≈ -4dB at 280 MHz.

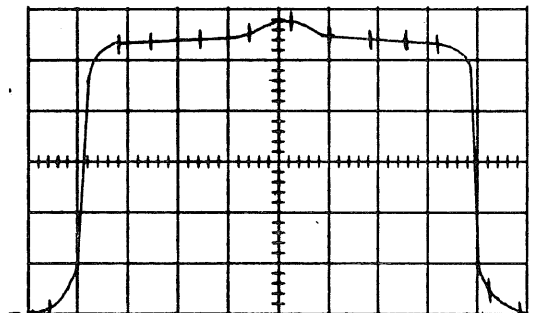
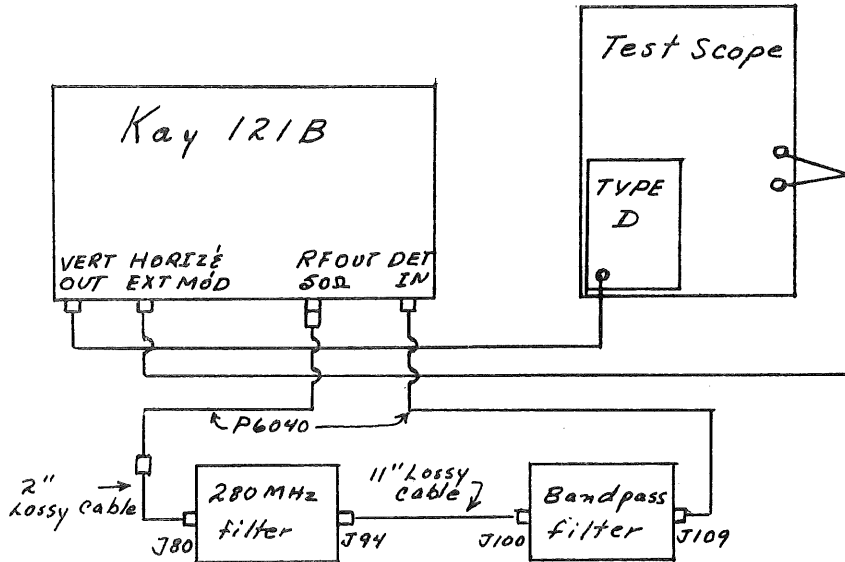

Fig. 6A

15. COMBINED FILTERS

a. Setup

Make connections as in the following diagram:



b. Check 280 MHz filter and bandpass filter response

Compromise the filter adjustments as necessary for the smoothest overall response of the 150 MHz to 250 MHz detected display. Work for the smoothest overall response consistent with $\leq 1.5\text{dB}$ down at 150 MHz and 250 MHz.

c. Check overall system flatness:
 $\pm 1.5\text{dB}$ from 870 MHz to 2050 MHz

Make all connections between the honeycomb chassis and the test plug-in. Connect the test plug-in to the plug-in scope with a flexible extension and turn the POWER ON.

Set the test plug-in IF CENTER FREQ to 000, and DISPERSION RANGE to MHz/CM. Set the HP608D frequency to 200 MHz and connect it to the test plug-in RF INPUT. Switch the DISPERSION between 10 and .2 keeping the trace centered at each step by adjusting Center Freq Cal, R253. Return the DISPERSION to 10. Center the trace by adjusting Swp Center, R204. Remove the HP608D connection and connect the TYPE 184. Set the TYPE 184 for $.1\mu\text{s}$ (10 MHz) marks. Adjust the DISP CAL for 1 mark/cm.

c. Use the 1L20-1L30 square pin connector extension cable to make appropriate connections.

15c. (cont'd)

Remove the TYPE 184 connection and connect the Kay 121B RF OUT to RF INPUT. Change the plug-in scope TIME/CM to 20mSEC. Set the Kay 121B RF ATTEN to -50dB. Adjust C137 and L134 for optimum flatness. If the flatness is not within ± 1 dB repeat steps 15a through c, or compromise the filter adjustments slightly. Remove the Kay 121B connection and connect the HP8614A to RF INPUT. Set the plug-in scope TIME/CM to 5mSEC. Set the RF CENTER FREQ to 870 MHz and HP8614A frequency to 910 MHz. The signal should be displayed at the left edge of the graticule. Tune the RF CENTER FREQ to move the trace to the right edge of the graticule while checking the amplitude of the display. Continue in this manner, shifting the trace to the left with the HP8614A frequency control, then to the right with the TYPE 1L30 RF CENTER FREQ control. Check the flatness from 870 MHz to 2050 MHz.

Make the final evaluation of overall system flatness with the honeycomb chassis resting bottom down on a metal plate to duplicate assembled conditions.

THE END

FACTORY TEST LIMITS

B. PHASE LOCK SUBASSEMBLY

QUALIFICATION

Factory test limits are qualified by the conditions specified in the main body of the calibration procedure. The numbers and letters to the left of the limits correspond to the factory calibration procedure steps where the check or adjustment is made. Instruments may not meet factory test limits if calibration or checkout methods and test equipment differ substantially from those in this procedure.

1. PRELIMINARY INSPECTION

2. RESISTANCE

3. PRESET ADJUSTMENTS

4. OSCILLATOR
 - b. Adjust INT REF FREQ range:
 at least 200 kHz

5. BALANCE

6. AVALANCHE VOLTS

7. INT REF FREQ ACCURACY
 - b. Check INT REF FREQ accuracy
Error: $\pm 0.1\%$, max with INT REF
FREQ control fully cw.

THE END

B. PHASE LOCK SUBASSEMBLY

1. PRELIMINARY INSPECTION

Check for unsoldered joints, rosin joints and long wire ends. Check for loose hardware and protruding parts. Check that transistors and diodes are properly oriented in their sockets. Check for broken or distorted diode and capacitor clips. Correct all defects found.

2. RESISTANCE

Measure resistance from the outside foil to the points indicated in the following diagram: (Low resistance values measured on the $\Omega \times 1K$ scale, high resistance values measured on the $\Omega \times 100K$ scale.)

Approximate resistance measurements.

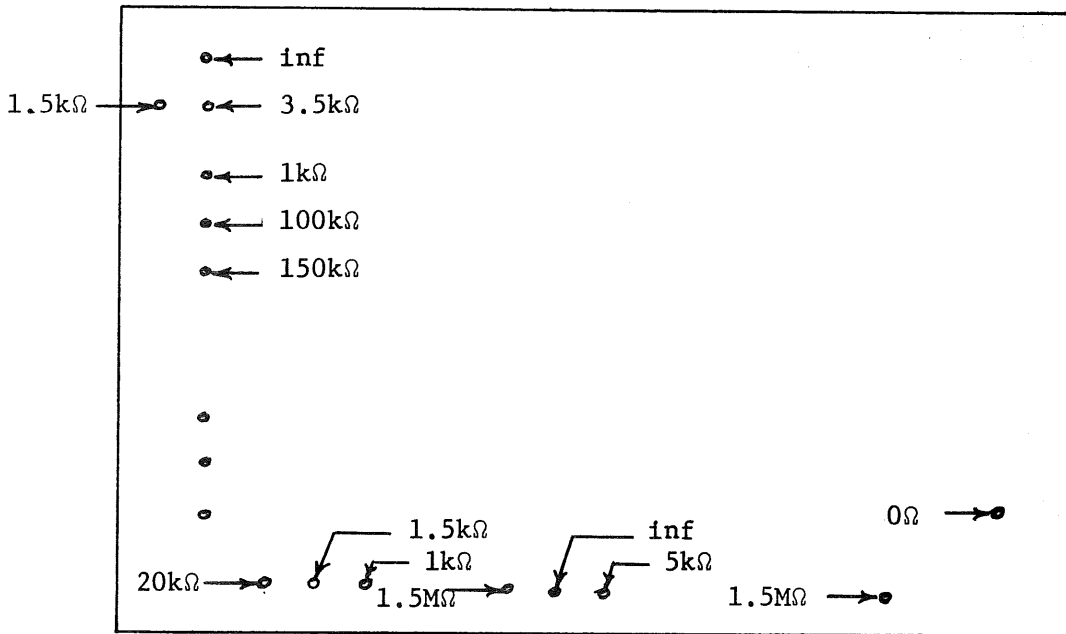

3. PRESET ADJUSTMENTS

Preset R1131 - avalanche volts, R1150 - Bands A and B balance and R1140 - B and C balance to midrange. Preset L1104 and L1108 approximately 3/4 of the way in.

4. OSCILLATOR

a. Setup

Remove the leads from the phase lock square pin connector strip on the TYPE 491 (calibrated test instrument). Connect the leads to the proper pins on the TYPE 491 phase lock test jig. Insert the phase lock subassembly into the TYPE 491 Phase lock test jig and connect the leads as in the following diagram:

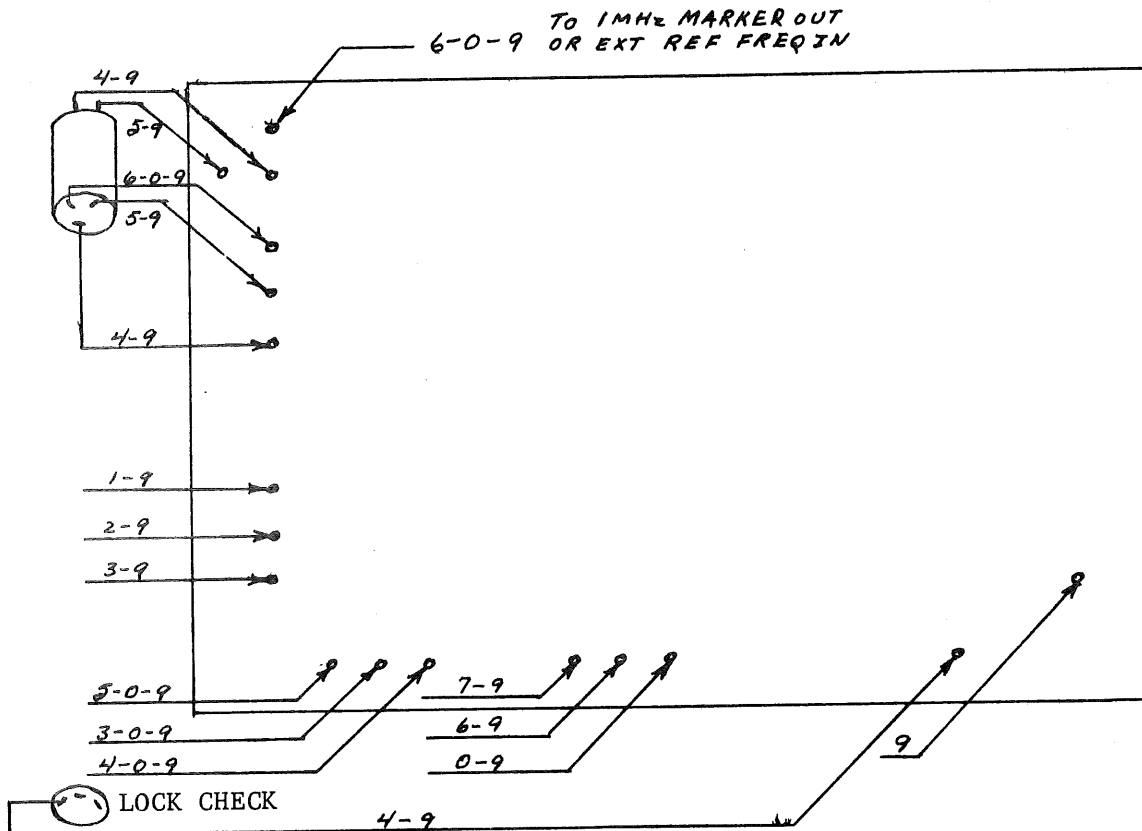

Connect the cables from TYPE 491 oscillators to J1150 (Band B) and J1140 (high oscillator). Connect a 50Ω cable between the 1 MHz MARKERS OUT OR EXT REF FREQ IN connectors on the TYPE 491 phase lock test jig and the TYPE 491.

4. (cont'd)

- b. *Adjust INT REF FREQ range: at least 200 kHz*

Set DISPERSION RANGE to kHz/DIV and DISPERSION to 50. Adjust L1104 for a minimum of 4 div of movement of the display as the INT REF FREQ is rotated through its range. Turn the INT REF FREQ on and off while adjusting L1108 for minimum delay in markers starting.

5. BALANCE

Turn INT REF FREQ OFF. Adjust FINE RF CENTER FREQ to its electrical center. (0 volts at the base of Q1180). Place the band selector in the band C position.

Depress the LOCK CHECK button. Adjust Band C Bal, R1140 to center the display on the TYPE 491 graticule. Change the Band Selector to Band B. Adjust Band A and B Bal to center the display on the TYPE 491 graticule.

Change the Band Selector to Band A. Check that display is centered on the TYPE 491 graticule.

6. AVALANCHE VOLTS

- a. *Adjust Avalanche Volts, R1131*

Connect a 10X probe from the collector of Q1121 to the input of the TYPE 1A1 in the test scope. Turn the INT REF FREQ on and adjust R1131, avalanche volts for a display of negative pulses of uniform amplitude (see Fig. 1B and 2B).

Turn the INT REF FREQ OFF and check that the oscillator does not free run (display of 1 MHz markers on test scope must disappear).

- b. *Check EXT REF FREQ IN function*

Connect TYPE 191 -- 50Ω GR to BNC Termination -- 50Ω cable -- TYPE 491 Phase lock 1 MHz MARKERS OUT or EXT REF FREQ IN. Set the TYPE 191 for 1V of signal.

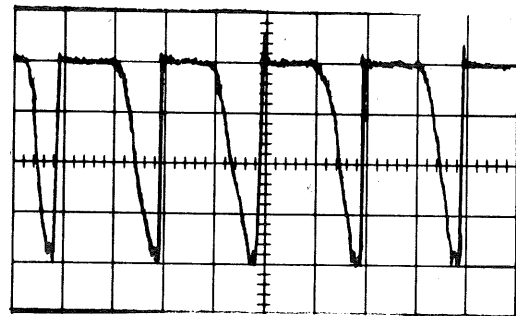

Fig. 1B

Correct adjustment of R1131
2V/CM - 10X probe - .5μs/cm

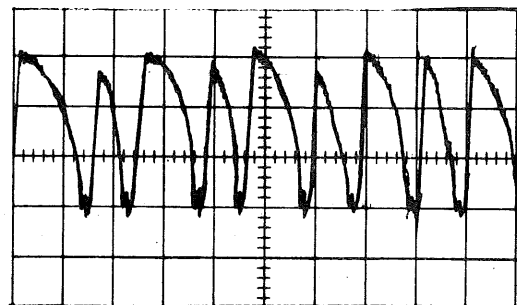

Fig. 2B

Incorrect adjustment of R1131
2V/CM - 10X probe - .5μS/cm

6b. (cont'd)

Vary the TYPE 191 from 1 MHz to 5 MHz and check the test scope display for no frequency count down.

Remove the 10X probe from the collector of Q1121. Set the TYPE 191 frequency to 5 MHz and check for beat frequency displays on the TYPE 491 as the RF CENTER FREQUENCY is tuned throughout its range on all bands. Remove the TYPE 191 signal and turn on the INT REF FREQ again. Check for beat frequencies displayed as the RF CENTER FREQUENCY is tuned throughout its range on all bands.

6b. If adjustment of R1131 fails to stop count down it may be necessary to select Q1121.

Excessive noise on the INT REF FREQ display may be due to defective matched diodes.

Diode impedance in Band C can prevent vertical positioning of trace during lock tests. Reverse diodes, or exchange with A or B Band, or install a new set as required.

7. INT REF FREQ ACCURACY

a. Setup

Connect the TYPE 184 MARKER OUTPUT to TYPE 1A1 INPUT CHANNEL 1. Connect a 50 Ω cable from the TYPE 491 phase lock test jig 1 MHz MARKER OUT OR EXT REF FREQ IN connector to TYPE 1A1 CHANNEL 2 INPUT. Adjust CHANNEL 1 and 2 VOLTS/CM for equal deflection on the test scope, then set TYPE 1A1 MODE to ADD. Set the test scope TIME/CM to 1mSEC and trigger the test scope.

b. Check INT REF FREQ accuracy *Error: $\pm 0.1\%$ max with INT REF FREQ control fully cw*

Turn the TYPE 491 phase lock test jig INT REF FREQ control fully cw and check for a maximum of 10 zero crossings on the test scope CRT.

THE END

FACTORY TEST LIMITS

C. COMPLETE TYPE 491

QUALIFICATION

Factory test limits are qualified by the conditions specified in the main body of the calibration procedure. The numbers and letters to the left of the limits correspond to the factory calibration procedure steps where the check or adjustment is made. Instruments may not meet factory test limits if calibration or checkout methods and test equipment differ substantially from those in this procedure.

Power Supply	Power Selector (VAC)			Test Point VA & blanking board	Max Error	max ripple
	LO	M	HI			
-10V	90	104	112	Pin L	±1% (-9.9 to -10.1V)	1mV
	110	126	136			
+10V	90	104	112	Pin M	±3% (+9.7 to +10.3V)	2mV
	110	126	136			
+150V	90	104	112	Pin N	±3% (+145.5 to +154.5V)	5mV
	110	126	136			

1. PRELIMINARY INSPECTION

2. RESISTANCE

3. TYPE 491 PRESETS

4. POWER SELECTOR AND FUSES

5. POWER SUPPLIES

a. Check and adjust low voltage power supplies as in the following table:

Supply	Test Point VA & Blanking Board	Adjust	Max Error
-10V	Pin L	R968 (P.S. board)	±1% (-9.9V to -10.1V)
+10V	Pin M	---	±3% (+9.7V to +10.3V)
+150V	Pin N	---	±3% (+145.5V to +154.5V) ^{*b.}

b. Adjust high voltage power supply
Voltage: -3670V ±5%

c. Adjust intensity range, R1032
800mA ±2%

d. Check power supply ripple and regulation as in the following table:

5d. (cont'd)

6. TRACE ALIGNMENT

- a. Adjust Trace Rotation, R672
Range: 6°, min
- b. Check vertical geometry:
curvature 0.5 minor div, max
- c. Check horizontal geometry:
curvature 0.5 minor div, max

7. CRT

8. SCALE ILLUM

- ccw - no illumination
- cw - full illumination

9. GAIN

- a. Check Vert Gain adjustment range:
±10%, min
- Adjust Vert Gain, R672
Error: ±2%, max

10. ↑ POSITION + & -9 div, min
from graticule center

11. TRIGGER

- b. Adjust Trig Level Center, R724 and check internal trigger sensitivity:
+ & - triggering on 0.2 div, max

11. (cont'd)

- c. Check external trigger sensitivity
0.2V, max - 20 Hz to 100 kHz
- d. Check line triggering: proper slope + & -

12. SWEEP CALIBRATION

- a. Adjust sweep length, R759: 7.5V \pm 6%
sawtooth at Q800 emitter
- b. Adjust Gain, R813 and sweep Cal, R787
Sweep length: 10.5 div \pm 0.2 div, max
sweep cal error: \pm 2%, max over center
8 graticule divisions
- c. Check TIME/DIV accuracy and linearity
Accuracy error: \pm 2% over center 8
graticule divisions
linearity error: \pm 2%, max over any 1 div
segment of center 8 divisions
- d. Check TIME/DIV VARIABLE range: 2.5:1, min

13. POSITION \leftrightarrow Min range: ends of
sweep to graticule center

14. SAWTOOTH OUT 0.08V P to P \pm 10%, max

15. SWEEPER

- a. Set RF Amplitude, R356 Approx -0.9VDC
- c. Check sweeper latch-up: no latch-up
+ & - 2 major div of IF CENTER FREQ
dial on all DISPERSION settings.

16. IF CENTER FREQUENCY

- a. Adjust Center Frequency Balance, R341:
stable display as DISPERSION is changed
- b. Adjust Sweep Center, R303: Display
centered with DISPERSION RANGE at
MHz/DIV and DISPERSION at 10.

17. DISPERSION

- a. Adjust DISPERSION CAL, R308 and
10 MHz linearity, C358: Dispersion
error \pm 2%, max; linearity error
 \pm 2%, max
- * b. Check MHz/DIV accuracy and linearity

DISPERSION

<u>(MHz/DIV)</u>	<u>Max Error</u>
10	\pm 2%
5	\pm 2.5%
2	\pm 4%
1	\pm 5%
.5	\pm 8%
.2	\pm 10%

Non-linearity \pm 2%, max over the
center 8 div of a 10 div display

- c. Adjust kHz/DIV Cal, R399 and
C384-C385
Dispersion error: \pm 2%, max
Linearity error: \pm 2%, max
- * d. Check kHz/DIV ranges
Error: \pm 2.5%, max

18. AMPLIFIER RESPONSE

- b. Adjust Variable resolution amplifier
response: symmetrical waveform
- c. Adjust resolution filter and
100 kHz Cal Dip -3dB max
Display width 100-120 kHz at 6dB
point with RESOLUTION fully cw.

19. INCIDENTAL FM

- * b. Check IF for incidental FM:
less than 200 Hz
- * c. Check range A LO + IF without
phase lock for incidental FM:
less than 2 kHz
- * d. Check range B LO + IF without phase
lock for incidental FM: less
than 2 kHz
- * e. Check range C LO + IF without phase
lock for incidental FM: less
than 2 kHz
- * f. Check LO + IF with phase lock
for incidental FM: less than
300 Hz

* 20. IF CENTER FREQ AND FINE

DISPERSION RANGE MHz/DIV	minimum range	
	IF CENTER FREQ	FINE
DISPERSION .2 to 5	+ & - 25 MHz	+ & - 1 MHz
DISPERSION 10	+ & - 10 MHz	+ & - 1 MHz
DISPERSION RANGE kHz/DIV		
DISPERSION to 500	+ & - 2.5 MHz	+ & - 50 kHz

* 21. RF CENTER FREQUENCY DIAL ACCURACY

±(2 MHz +1% of dial reading)

22. DISPLAY FLATNESS

- * b. Check band 1 display flatness
±1.5dB + and - 25 MHz of RF CENTER FREQUENCY
- * c. Check bands 2 through 8 for display flatness: ±1.5dB + & - 50 MHz of RF CENTER FREQUENCY

23. VIDEO FILTER

- b. Integrated signal display

24. PHASE LOCK CIRCUIT

- a. Check 1 MHz oscillator starting and adjust L1108: minimum delay in starting, no signal in OFF position.
- b. Adjust and check INT REF FREQ range: 2 kHz, min
- * c. Check INT REF FREQ accuracy
Error ±0.1%, max with INT REF FREQ control fully cw
- d. Check LOCK CHECK function: Beat frequencies through range of RF CENTER FREQUENCY
- e. Check EXT REF FREQ IN
Phase lock from 1-5 MHz and 1-5V P to P

* 25. SENSITIVITY

Check sensitivity as in the following table:

Band	1 kHz	10 kHz
	Resolution	Resolution
1	-100dBm, min	-80dBm, min
2	-110dBm, min	-90dBm, min
3	-105dBm, min	-85dBm, min
4	-110dBm, min	-90dBm, min
5	-100dBm, min	-80dBm, min
6	- 95dBm, min	-75dBm, min
7	- 90dBm, min	-70dBm, min
8 (18GHz)	- 80dBm, min	-60dBm, min
8 (40GHz)	- 70dBm, min	-50dBm, min

26. SPURIOUS SIGNALS

- * a. Check Band A spurious response
spurious signals: 2X noise, max
- * b. Check Band B & C spurious response
spurious signals: 2X noise, max

27. IF ATTENUATOR

- * b. Check IF ATTENUATOR accuracy:
51dB in 1dB steps ±0.1dB/dB

* 28. GAIN CONTROL 50dB, min

29. DISPLAY FUNCTIONS

- * a. Check LOG dynamic range: 40dB, min
- * b. Check LIN dynamic range: 26dB, min
- * c. Check SQ LAW dynamic range:
13dB total range, min

30. TO RECORDER

Check TO RECORDER output; 50mV P to P, min into a 600Ω load with 8 div display

* Indicates measurement characteristic; test equipment used must be traceable to the NBS for instrument certification.

31. CONTRAST

- b. Contrast between upper and lower halves of screen ± 1 div

32. MIXER PEAKING

C. COMPLETE TYPE 491

1. PRELIMINARY INSPECTION

a. *General*

Check for unsoldered joints, rosin joints, poor lead dress and long wire ends. Check for loose hardware and protruding parts. Check controls for smooth mechanical operation, proper indexing and clearance between knob and front panel.

b. *CRT*

Inspect the CRT for phosphor defects, scratches, chips and cracks around neck pins. Check that the neck pin connectors are on the proper neck pins and are tight. Check graticule alignment and face plate tilt. Check that CRT hardware is tightened. Correct all defects found.

2. RESISTANCE

Check power supply resistance to ground as follows:

<u>Supply</u>	<u>Test Point VA & Blanking Board</u>	<u>Approximate resistance</u>
+10V	Pin M	80Ω
-10V	Pin L	300Ω
+150V	Pin N	2kΩ

Pin Q removed (heater voltage for oscillator grounds +10V)

3. TYPE 491 PRESETS

INTENSITY	ccw
FOCUS	ccw
SCALE ILLUM	ccw
ASTIGMATISM	ccw
INTENSIFIER	ccw
TIME/DIV	1mS
TIME/DIV VARIABLE	cw (CAL)
BAND SELECTOR	B MHz
TRIGGER LEVEL	FREE RUN
DISPERSION RANGE	MHz/DIV
DISPERSION	10 (outer scale)
RESOLUTION	coupled
VIDEO FILTER	DOWN (OUT)
CONTRAST	ccw
INTENSITY RANGE (int)	ccw

3. Do not preset the honeycomb adjustments. The honeycomb subassembly has been pretuned.

4. POWER SELECTOR AND FUSES

a. Check fuses

Remove the power selector cover and check that the proper fuses are installed. Set the power selector RANGE to 230 and M (see Fig. 1C). Replace the power selector cover.

b. Check power selector

Connect the TYPE 491 power cord to the TYPE 76 TU outlet. Adjust the TYPE 76 TU for 115 VAC line. Turn the TYPE 491 POWER ON and measure the AC voltage between T900 terminals 13 and 14 (approximately 84 VAC). Remove the TYPE 491 power cord from the TYPE 76 TU outlet. Remove the power selector cover and set RANGE to 115. Reconnect the TYPE 491 power cord to TYPE 76 TU outlet. Check that the AC voltage between T900 terminals 13 and 14 is twice that previously measured.

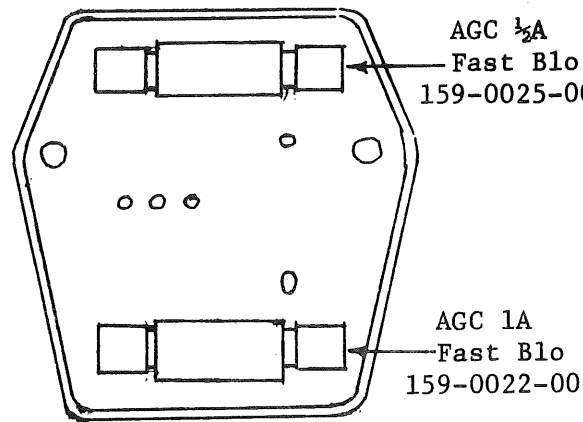

Fig. 1C

5. POWER SUPPLIES

a. Check and adjust low voltage power supplies

Check and adjust supplies as in the following table:

Supply	Test Point VA & blanking board	adjust	max error
-10V	Pin L	R968 (P.S. board)	±1% (-9.9V to -10.1V)
+10V	Pin M	--	±3% (+9.7V to +10.3V)
+150V	Pin N	--	±3% (+145.5V to +154.5V)

b. Adjust high voltage power supply
Voltage: -3670V ±5%

Turn the TYPE 491 POWER OFF. Remove the white cover from the CRT socket. Set the multimeter to a range suitable to measure 3670VDC and connect the multimeter between CRT pin 14 and ground. Turn the TYPE 491 POWER ON. Adjust R1000 (on power supply board), for -3670 volts. Turn the TYPE 491 POWER OFF. Replace the CRT socket cover.

a. The high voltage supply must be operating before the +150V supply will regulate. If the high voltage supply is not operating, connect a 30V battery between the +150V supply and the HV supply as follows:
+ lead to AQ
- lead to AL on power supply board

5. (cont'd)

c. Adjust intensity range, R1032
800mA ±2%

Remove the high voltage fuse, F1008, located inside the rear panel near the power supply board. Set the multimeter to a range suitable to measure 800mA and connect the meter leads between the fuse clips. (Black lead to the end having the white-orange wire and red lead to the remaining fuse clip.) Turn the TYPE 491 POWER ON. Turn the INTENSITY full cw. Adjust the intensity range, R1032, (rear panel), for an 800mA reading on the multimeter. Turn the TYPE 491 POWER OFF. Remove the meter leads. Check that the fuse is a 1 amp, fast blo and reinstall the fuse in the holder. Turn INTENSITY control ccw then turn the TYPE 491 POWER ON.

d. Check power supply ripple and regulation
Check ripple and regulation as in the following table:

Power Supply	Power Selector (VAC)			Test Point VA & blanking board	max error	max ripple
	LO	M	HI			
-10V	90	104	112	Pin L	±1% (-9.9V to -10.1V)	1mV
	110	126	136			
+10V	90	104	112	Pin M	±3% (+9.7V to +10.3V)	2mV
	110	126	136			
+150V	90	104	112	Pin N	±3% (+145.5V to +154.5V)	5mV
	110	126	136			

d. Use the TYPE 76 TU to vary the AC line voltage, the multimeter to check regulation and the test scope with TYPE D plug-in to check ripple.

6. TRACE ALIGNMENT

a. Adjust Trace Rotation, R672:
Range 6°, min

Set TRIGGER LEVEL to FREE RUN. Center the trace vertically. Rotate the Trace Rotation control from full ccw to full cw and check the Trace Rotation control range (see Fig. 2C). Adjust the Trace Rotation control to align the trace with the center graticule line.

b. Check Vertical Geometry: curvature
0.5 minor div, max

Connect the TYPE 184 MARKER OUTPUT through a 1X probe to pin H on the VA & blanking board. Press the .1ms and lms buttons on the TYPE 184. Adjust TYPE 491 TRIGGER LEVEL for a stable display and adjust

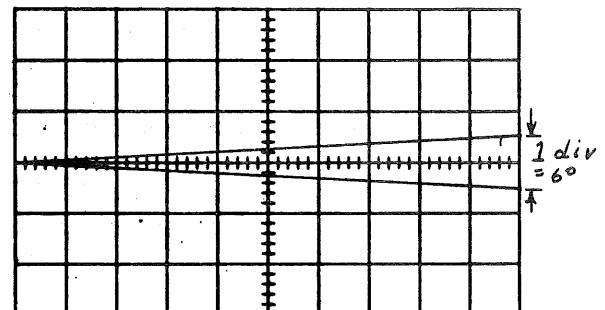

Fig. 2C

6b. (cont'd)

GAIN for an 8 div display. Adjust FOCUS, ASTIGMATISM and INTENSITY for a well defined display. Check that the curvature of the trace at the 0 and 10 div graticule lines does not exceed 0.5 minor div.

c. *Check Horizontal Geometry: curvature 0.5 minor div, max*

Disconnect the 1X probe from pin 11 on the VA & blanking board. Position the trace to the top and bottom graticule lines and note the deviation from a straight line.

7. CRT

Check the CRT for double peaking, flare, grid emission, cathode interface, charging, burrs and adequate scan area.

7. CRT defects

This is a simple description of CRT defects. For a more detailed description see the CRT checkout procedure or consult with a trained CRT checker.

8. SCALE ILLUM

ccw - no illumination
cw - maximum illumination

Rotate the SCALE ILLUM control through its range. Check for a smooth change in illumination with no illumination ccw and maximum illumination cw.

9. GAIN

a. *Check Vert Gain Adjustment range:
±10%, min*

Connect a 0.5V SAC signal via a 1X probe to pin H on the VA & Blanking board. Rotate the Vertical Gain, R672 from full ccw to full cw and check the TYPE 491 display for a minimum change of from 4.5 div to 5.5 div of deflection.

9. (cont'd)

- b. *Adjust Vert Gain, R672*
Error: $\pm 2\%$, max

Adjust R672 for exactly 5 div of deflection.

- c. *Check vertical compression and expansion: ± 0.5 minor div, max*

Change the SAC AMPLITUDE to .2 VOLTS. Move the display to the top, center and bottom of the graticule and check for 2 major div ± 0.5 minor div of display amplitude.

10. \updownarrow POSITION

+ & - 9 div, min from
 graticule center

Remove the 1X probe from pin H of the Vertical Amp & Blanking board. Center the trace. Set the multimeter to a range suitable for reading 150 VDC and connect the red multimeter lead to pin A and the black multimeter lead to pin B of the Vertical Amp & Blanking board. Note the meter reading. Move the trace to the top graticule line and again note the meter reading. Continue moving the trace upward until the cw limit of the \updownarrow POSITION control is reached. Check for a change of at least twice the difference in the two meter readings noted. Return the trace to graticule center. Reverse the meter polarity and repeat the above procedure while moving the trace in a downward direction. Center the trace and check that the index mark on the knob is approximately at the center of the arrow.

11. TRIGGER

- a. *Setup*

TRIGGER SLOPE	+
TRIGGER SOURCE	INT
TRIGGER LEVEL	centered
TIME/DIV	.5mS

Set the SAC AMPLITUDE to .2 VOLTS and connect SAC OUTPUT -- 50 Ω cable -- BNC T -- TRIG IN -- 1X probe -- pin H of Vertical Amp & Blanking board.

11. (cont'd)

- b. *Adjust Trig Lev Center, R724 and check internal trigger sensitivity: + & - triggering 0.2 div, max*

Connect a jumper between the junction of R702, C702, R703 and ground. Adjust the Trig Lev Center, R724 for stable triggering. Progressively reduce the SAC AMPLITUDE to 20m VOLTS while adjusting R724 for stable triggering on both + and - settings of the SLOPE switch.

- c. *Check External Trigger Sensitivity: 0.2V, max - 20 Hz to 100 kHz*

Change the TYPE 491 TRIGGER SOURCE to EXT. Remove the 50Ω cable from the SAC OUTPUT. Remove the jumper from the junction of R702, C702, R703 and ground. Connect the 50Ω cable to the HP241A with a clip lead adapter. Monitor the signal amplitude at pin H of the Trigger, Sweep Gen & Horiz Amp board with the test scope. Check TYPE 491 at several frequencies from 20 Hz to 100 kHz for stable triggering on a 0.2V signal.

- d. *Check line triggering: proper slope + and -*

Remove the cables and BNC T connector from TYPE 491 TRIG IN. Change the TRIGGER SOURCE switch to LINE. Use a 10X probe and clip lead adapter to connect from Transformer terminal 17 to Vertical Amp & Blanking board pin H. Set TIME/DIV to 2mS. Move the SLOPE switch to + and - and check that the sweep triggers on the proper slope.

d. Use caution to avoid short circuiting Vertical Amp pins with the clip lead adapter.

12. SWEEP CALIBRATION

- a. *Adjust Sweep Length, R759: 7.5V ±6% sawtooth at Q800 emitter*

Set Gain, R813 and sweep cal, R786 to midr. Set TYPE 1A1 VOLTS/CM to .2 and connect a 10X probe from pin W of TYPE 491 trigger, Sweep Gen and Horiz Amp board to TYPE 1A1 INPUT. Set Sweep Length, R759 for 3.75cm of vertical deflection.

12. (cont'd)

- b. *Adjust Gain, R813 and Sweep Cal, R787*
Sweep length: 10.5 div ±0.2 div, max
Sweep Cal error: ±2%, max over the
center 8 graticule divisions

Connect TYPE 184 MARKER OUTPUT -- 1X probe -- TYPE 491 Vertical Amp and Blanking board pin H. Set the TYPE 184 for 1mS and .1mS markers. Set the TYPE 491 TIME/DIV to 1mS. Adjust the Sweep Cal, R787 for one 1mS and ten .1mS marks/div between the 1 div and 9 div graticule lines (see Fig. 3C). Adjust R813 to produce a display that is 10.5 div in length.

- c. *Check TIME/DIV accuracy & linearity*
Calibration error: ±2%, max over the
center 8 graticule divisions
Linearity error: ±2%, max over any
1 div segment of the center 8 div

Check TIME/DIV accuracy as in the following table:

<u>TIME/DIV</u>	<u>TYPE 184</u>	<u>Check for</u>
10µS	10µS	1 mark/div
20µS	10µS	2 marks/div
50µS	50µS	1 mark/div
.1mS	.1mS	1 mark/div
.2mS	.1mS	2 marks/div
.5mS	.5mS	1 mark/div
1mS	1mS	1 mark/div
2mS	1mS	2 marks/div
5mS	5mS	1 mark/div
10mS	10mS	1 mark/div
20mS	10mS	2 marks/div
50mS	50mS	1 mark/div
.1 S	.1 S	1 mark/div
.2 S	.1 S	2 marks/div
.5 S	.5 S	1 mark/div

- d. *Check TIME/DIV VARIABLE*
Range: 2.5:1, min

Press the TYPE 184 10mS MARKER SELECTOR. Set the TYPE 491 TIME/DIV to 1mS and turn the TIME/DIV VARIABLE control full ccw. Check for at least 4 markers in 10 divisions.

- b. It will be necessary to repeat the adjustment of R787 and R813 as these adjustments interact.

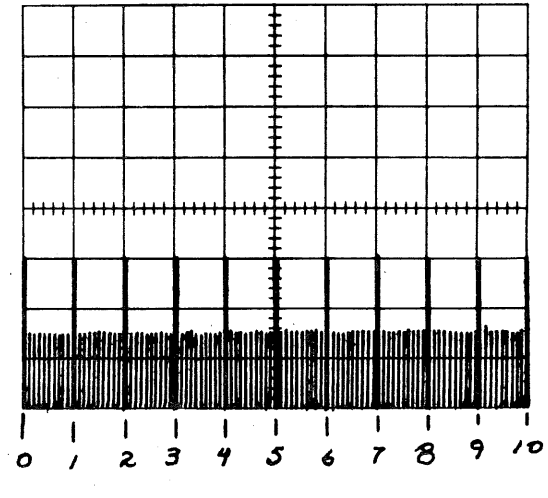

Fig. 3C

13. POSITION ↔

Min range: ends of the sweep to graticule center

Rotate the POSITION ↔ control full cw. Check that the left edge of the trace may be positioned to graticule center. Rotate the POSITION ↔ control full ccw. Check that the right edge of the trace may be positioned to graticule center.

13. The movement of the trace should be smooth as the POSITION ↔ control is rotated.

14. SAWTOOTH OUT

0.08V P to P ±10%, max

Connect a 50Ω cable from the SAW OUT connector at the rear of the TYPE 491 to the test scope plug-in input. Set the plug-in for .01V/cm deflection factor. Check for a sawtooth waveform 8cm in amplitude.

15. SWEEPER

a. *Set RF amplitude, R356: -0.9V ±0.1V max*

Set the test scope TYPE 1A1 CHANNEL 1 VOLTS/CM to .02 and INPUT SELECTOR to DC. Connect a compensated 10X probe to TYPE 1A1 CHANNEL 1 INPUT. Establish zero volts by grounding the probe tip, then connect the pin P of the honeycomb connector strip. Adjust R356 (IF control board) for -0.9V.

b. *Check Sweeper Waveform*

Move the probe to pin M of the honeycomb connector strip. Check for a waveform similar to Fig. 4C.

c. *Check sweeper latch-up: no latch up + & - 2 major div of IF CENTER FREQ dial*

Set the IF CENTER FREQ dial 2 major div cw from 000. Change the DISPERSION RANGE from MHz/DIV to kHz/DIV and check that the sweeper waveform is present.

Set the IF CENTER FREQ dial 2 major div ccw from 000 and again check that the sweeper waveform is present as the DISPERSION RANGE is switched from MHz/DIV to kHz/DIV. Check on several DISPERSION settings.

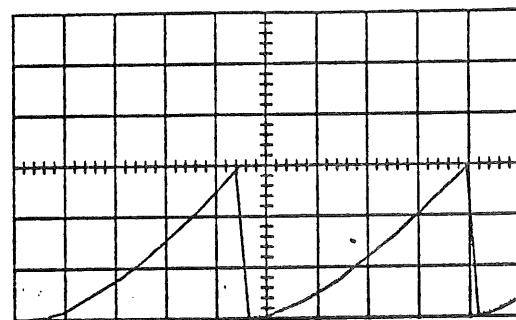

Fig. 4C

16. IF CENTER FREQUENCY

- a. *Adjust Center Frequency Balance, R341: stable display when DISPERSION is changed*

Connect HP608D -- N to BNC adapter -- 50Ω cable -- TYPE 491 BAND B INPUT. Turn IF CENTER FREQ to 0-0-0 and center the FINE control. Change VIDEO FILTER to OFF.

Set the HP608D for a 200 MHz signal. Rotate the DISPERSION switch through its range and adjust R341 for no display movement.

- b. *Adjust Sweep Center, R303: Display centered with DISPERSION RANGE at MHz/DIV and DISPERSION at 10*

Set the DISPERSION RANGE to MHz/DIV and DISPERSION to 10 (outer scale). Adjust R303 to place the display at graticule center.

17. DISPERSION

- a. *Adjust DISPERSION CAL, R308 and 10 MHz Linearity, C358. Dispersion error: ±2%, max Linearity error: ±2%, max*

Set the MC Model 111B for 10 MHz markers and connect it to TYPE 491 RF INPUT B. Adjust the DISPERSION CAL to the left of BAL on TYPE 491 front panel for 1 mark/div ±1 minor div (2 MHz) over the center 8 div of a 10 div display. Adjust C358 for optimum linearity.

- b. *Check MHz/DIV accuracy and linearity*

Check dispersion accuracy and linearity as in the following table:

DISPERSION (MHz/DIV)	MC Model 111B	Max error	display
10	10 MHz	±2% (2 MHz)	1 mark/div
5	10 MHz	±2.5% (1.25MHz)	2 marks/div
2	1 MHz	±4% (0.8 MHz)	1 mark/2 div
1	1 MHz	±5% (0.5 MHz)	1 mark/div
.5	.1 MHz	±8% (0.4 MHz)	2 marks/div
.2	.1 MHz	±10% (0.2 MHz)	1 mark/2 div

Non-linearity: ±2% over the center 8 div of a 10 div display.

- a. It may be necessary to select cables in the wide band discriminator to obtain optimum linearity.

- b. Dispersion accuracy and linearity in the MHz/DIV range is measured over the center 8 div of a 10 div display + and - 25 MHz of 0-0-0 on the IF CENTER FREQ dial (+ and - 2½ turns).

17. (cont'd)

- c. Adjust kHz/DIV Cal, R399 and C384-C385:
 Dispersion error $\pm 2\%$, max
 Linearity error $\pm 2\%$, max

Remove the MC Model 111B connection from the TYPE 491 RF INPUT B. Make connections and set controls as in the following diagram:

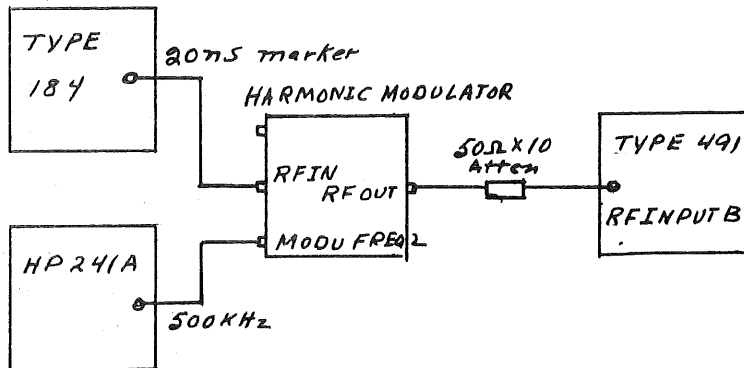

Change the DISPERSION RANGE to kHz/DIV and DISPERSION to 500. Center 200 MHz (4th harmonic of 20ns marker) with IF CENTER FREQ control. Adjust the HP241A for a 500 kHz signal. Adjust C384 and C385 simultaneously in opposite directions to obtain one mark/div while keeping 200 MHz centered. Adjust R399 for optimum linearity on the left side of the display.

- d. Check kHz/DIV ranges:
 Error $\pm 2.5\%$, max

Check all kHz/DIV ranges as in the following table:

<u>DISPERSION</u> (kHz/DIV)	<u>Modulation</u> <u>frequency</u>	<u>display</u>
500	500 kHz	1 mark/div
200	200 kHz	1 mark/div
100	400 kHz	4 marks/div
50	200 kHz	4 marks/div
20	80 kHz	4 marks/div
10	40 kHz	4 marks/div
5	20 kHz	4 marks/div
2	8 kHz	4 marks/div
1	4 kHz	4 marks/div

18. AMPLIFIER RESPONSE

- a. Setup

Make connections as in the following diagram:

18a. (cont'd)

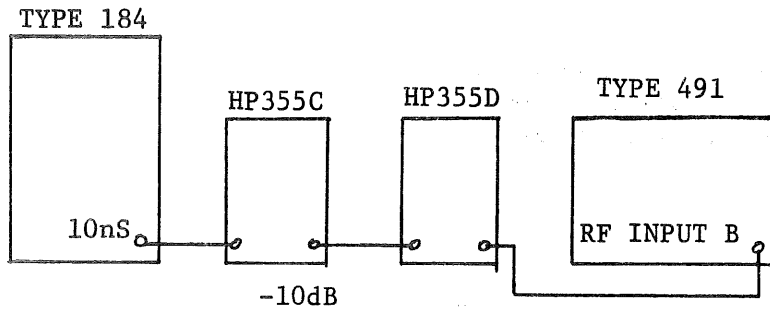

Connect a 50Ω cable from TYPE 491 SAW OUT to test scope TRIGGER INPUT. Set the test scope TIME/CM and TYPE 491 TIME/DIV to 20mS. Set the test scope TRIGGERING SOURCE to EXT and TYPE 491 TRIGGER LEVEL to FREE RUN. Connect a 10X probe from pin B of the honeycomb connector strip to test scope plug-in input.

b. *Adjust Variable Resolution Amplifier response: symmetrical waveform*

Adjust C504 and C508 for the most symmetrical waveform on the test scope (see Fig. 5C).

c. *Adjust resolution filter and 100 kHz Cal: Dip -3dB, max
Display width 100-120 kHz at 6dB point with RESOLUTION fully cw.*

Set the TYPE 491 DISPERSION RANGE to kHz/DIV and DISPERSION to 50. Uncouple the RESOLUTION knob and set it full cw (min). Set C601, C604, C607 and C610 for the most symmetrical waveform and maximum deflection consistent with not more than a 3dB dip in the center of the waveform. Adjust the 100 kHz Cal, R343 for a display that is 100 kHz to 120 kHz wide at the half-amplitude point (see Fig. 6C).

Set the RESOLUTION one position ccw and check that the display is from 50 kHz to 60 kHz wide at the half-amplitude point (see Fig. 7C).

b. The adjustment of C504 and C508 interact.

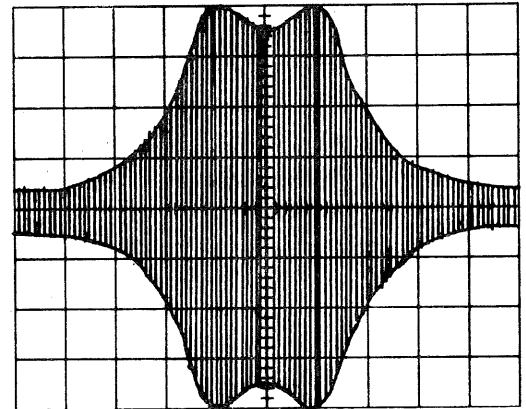

Fig. 5C

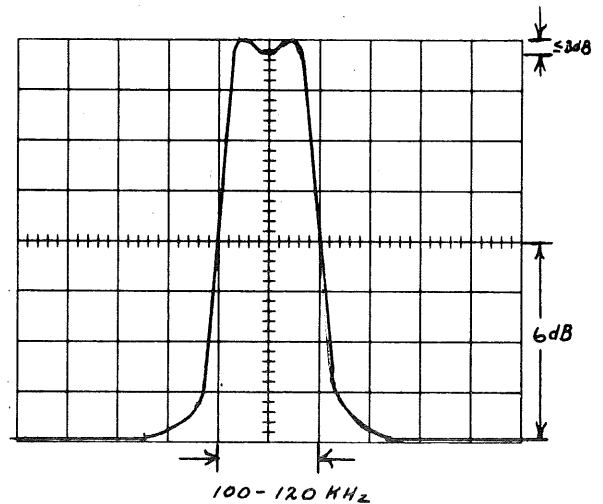

Fig. 6C

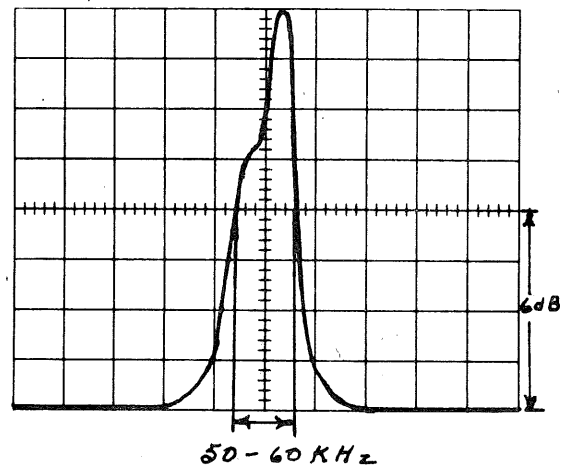

Fig. 7C

19. INCIDENTAL FM

a. Setup

Preset the TYPE 491 controls as follows:

DISPERSION RANGE	kHz/DIV
DISPERSION	1 (inner scale)
IF ATTENUATOR dB	OFF
INT REF FREQ	OFF-OR EXT REF FREQ IN
TIME/DIV	.5 S
Band Selector	A MHz

Connect TYPE 184 MARKER OUTPUT to TYPE 491 RF INPUT A and press the 10nS MARKER SELECTOR. Center the IF feed-through signal and adjust GAIN for 8 div of deflection.

b. Check IF for incidental FM: less than 200 Hz

Check that horizontal movement of the trace is less than 1 minor graticule division (see Fig. 8C).

c. Check range A LO + IF without phase lock for incidental FM: less than 2 kHz

Tune the RF CENTER FREQUENCY to 50 MHz. Check that horizontal movement of the trace is less than 2 major graticule divisions.

d. Check range B LO + IF without phase lock for incidental FM: less than 2 kHz

Move the signal connection from TYPE 184 MARKER OUTPUT to OUTPUT > 0.3V INTO 50Ω and from TYPE 491 RF INPUT A to RF INPUT B. Set TYPE 184 HF SELECTOR to 2nS. Set Band Selector to B MHz and tune the TYPE 491 RF CENTER FREQUENCY to the second harmonic of the TYPE 184 signal (1 GHz).

Check that horizontal movement of the trace is less than 2 major graticule divisions.

e. Check range C LO + IF without phase lock for incidental FM: less than 2 kHz

Move the TYPE 184 signal from RF INPUT B to RF INPUT C. Set Band Selector to C GHz and tune the RF CENTER FREQUENCY to the 8th harmonic of the TYPE 184 signal (4 GHz). Check that horizontal movement of the trace is less than 2 major graticule divisions.

19. Incidental FM is displayed as short-term horizontal jitter. Disregard longer term horizontal drift in checking incidental FM.

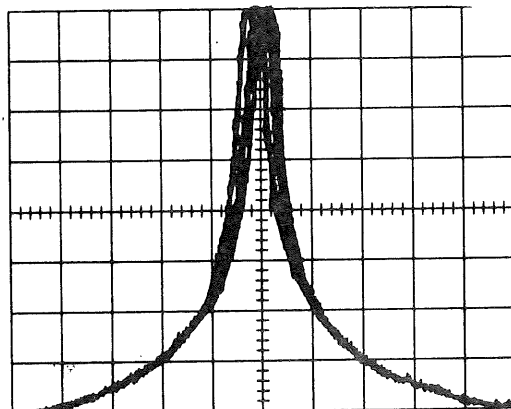

Fig. 8C

19c, d, e.

As an aid in locating signals start at wider DISPERSION settings, gradually narrowing the DISPERSION to 1.

19. (cont'd)

f. Check LO + IF with phase lock for incidental FM: less than 300 Hz

Press the LOCK CHECK button and tune the FINE RF CENTER FREQ for a zero beat as evidenced by widening of the trace. Release the LOCK CHECK button and position the display with IF CENTER FREQUENCY and FINE controls. Check that horizontal movement of the trace is less than 1.5 minor graticule division.

20. IF CENTER FREQ AND FINE

Check IF CENTER FREQ and FINE controls range as in the table following:

DISPERSION RANGE MHz/DIV	Minimum range	
	IF CENTER FREQ	FINE
DISPERSION .2 to 5	+ & - 25 MHz	+ & - 1 MHz
DISPERSION 10	+ & - 10 MHz	+ & - 1 MHz
DISPERSION		
DISPERSION RANGE kHz/DIV		
DISPERSION 1 to 500	+ & - 2.5 MHz	+ & - 50 kHz

21. RF CENTER FREQUENCY DIAL ACCURACY

±(2 MHz +1% of dial reading)

RF INPUT A, Band 1

<u>RF CENTER FREQUENCY dial setting</u>	<u>Signal Source</u>	<u>Tolerance</u>
10	HP608D	7.9-12.1 MHz
20	HP608D	17.8-22.2 MHz
30	HP608D	27.7-32.2 MHz
50	HP608D	47.5-52.5 MHz
80	HP608D	77.2-82.8 MHz
140	HP608D	136.6-143.4 MHz
170	HP608D	166.3-173.7 MHz
200	HP608D	196-204 MHz
220	HP608D	215.8-224.2 MHz
240	HP608D	235.6-244.4 MHz
250	HP608D	245.5-254.5 MHz
260	HP608D	255.4-264.6 MHz
270	HP608D	265.3-274.7 MHz
275	HP608D	270.25-279.75 MHz

RF INPUT B, Bands 2-3

270	HP608D	265.3-274.7 MHz
300	HP608D	295-305 MHz
400	HP608D	394-406 MHz
500	HP608D	493-507 MHz
600	HP612A	592-608 MHz
700	HP612A	691-709 MHz
800	HP612A	790-810 MHz
900	HP612A	889-911 MHz

RF INPUT C, Bands 4-8

1.5	HP8614A	1.483-1.517 GHz
2	HP8614A	1.987-2.022 GHz
2.5	HP8616A	2.473-2.527 GHz
3	HP8616A	2.968-3.032 GHz
3.5	HP8616A	3.463-3.537 GHz
4	HP8616A	3.958-4.042 GHz

22. DISPLAY FLATNESS

a. Setup

RF CENTER FREQUENCY	10 MHz
DISPERSION RANGE	MHz/DIV
DISPERSION	5
Band switch	A MHz

Set the HP608D frequency to 35 MHz and connect the HP608D signal to RF INPUT A.

22. Each time the signal generator frequency is changed it will be necessary to standardize the output amplitude.

22. (cont'd)

b. Check Band 1 display flatness:
 $\pm 1.5\text{dB}$ + & - 25 MHz of RF CENTER
 FREQUENCY

Check Band 1 display flatness as in the
 following chart:

TYPE 491 RF INPUT A, Band 1 RF CENTER
 FREQUENCY

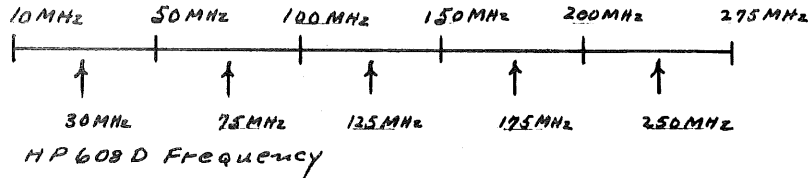

c. Check Bands 2 through 8 for display
 flatness: $\pm 1.5\text{dB}$ + & - 50 MHz
 of RF CENTER FREQUENCY

Change the DISPERSION to 10. Check Bands
 2 to 8 for display flatness as in the
 following charts:

TYPE 491 RF INPUT B Band 2 RF CENTER
 FREQUENCY

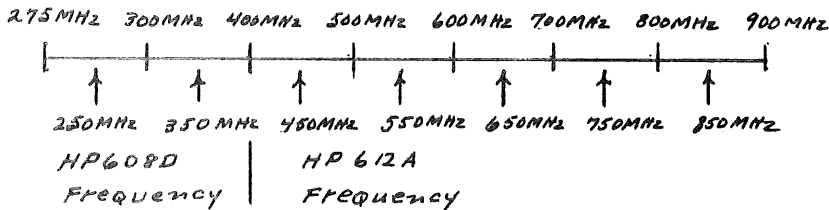

Continue in a similar manner checking flatness
 on all bands using the appropriate RF INPUT
 and signal source.

b. Set the signal source for
 an 8 div display then use the 1dB
 and 2dB IF ATTENUATORS to establish
 the -3dB point.

Move the display from the left
 edge of graticule to the right
 edge of the graticule with the
 RF CENTER FREQUENCY control.
 Check for no more than a $\pm 1.5\text{dB}$
 change in display amplitude.

23. VIDEO FILTER

a. Setup

TYPE 491

TIME/DIV	5mS
DISPERSION RANGE	kHz/DIV
DISPERSION	100
RESOLUTION (uncoupled)	5 (outer scale)
VIDEO FILTER	OFF
Band Selector	A MHz

23a. (cont'd)

Set the HP608D for a 200 MHz signal and connect to TYPE 491 RF INPUT A. Tune the RF CENTER FREQUENCY to center the 200 MHz signal.

b. *Check VIDEO FILTER operation:
Integrated signal display*

Change the VIDEO FILTER switch position to up (on). Check for an integrated signal display (see Fig. 9C). Change the TIME/DIV switch to .5 S. Change the VIDEO FILTER switch to OFF. There should be no appreciable change in the signal display with VIDEO FILTER on or off.

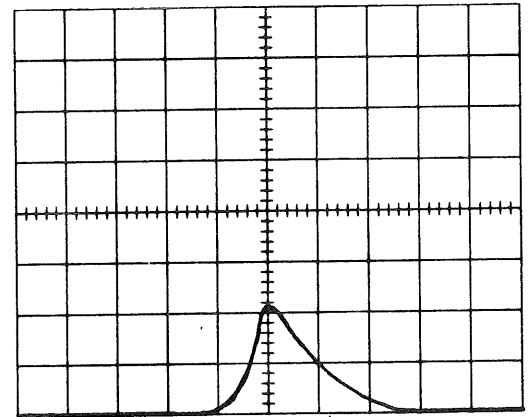

Fig. 9C

24. PHASE LOCK CIRCUIT

a. *Check 1 MHz oscillator starting and adjust L1108: minimum delay in oscillator starting. No signal in OFF position*

Connect 1 MHz MARKERS OUT -- 50 Ω cable -- RF INPUT A. Turn the INT REF FREQ control cw to the VARIABLE position and observe a display of 1 MHz markers on the TYPE 491. Turn the INT REF FREQ off and on several times and adjust L1108 for minimum starting delay.

b. *Adjust and check INT REF FREQ range:
2 kHz, min*

Connect TYPE 184 MARKER OUTPUT to TYPE 491 RF INPUT A. Press TYPE 184 μ s MARKER SELECTOR. Set TYPE 491 Band Selector to B MHz, DISPERSION RANGE to kHz/DIV and DISPERSION to 100. Tune the RF CENTER FREQUENCY to the 200th harmonic of the TYPE 184 signal (200 MHz). Rotate the INT REF FREQ control through its range and adjust L1104 for a range of 2 kHz (signal display should move 4 div as INT REF FREQ control is rotated through its range).

c. *Check INT REF FREQ accuracy
Error: $\pm 0.1\%$, max with INT REF FREQ control fully cw*

Remove the TYPE 184 signal from TYPE 491 RF INPUT A and connect it to TYPE 1A1 CHANNEL 1. Connect TYPE 491 1 MHz MARKERS OUT to TYPE 1A1 CHANNEL 2. Adjust

b. Typical INT REF FREQ range is: 1 MHz +300 Hz to +2300 Hz. The display is the 200th harmonic of the 1 MHz signal. The range of the INT REF FREQ control will also be related to the 200th harmonic, so 2000 Hz X 200 = 400 kHz with 100 kHz dispersion 4 div = 2000 Hz of range.

24c. (cont'd)

CHANNEL 1 & 2 VOLTS/CM for equal deflection, then set TYPE 1A1 MODE to ADD. Set the test scope TIME/CM to 1mSEC and trigger the test scope. Turn the TYPE 491 INT REF FREQ full cw and check for a maximum of 10 zero crossings on the test scope CRT.

d. *Check LOCK CHECK function: Beat frequencies throughout range of RF CENTER FREQUENCY*

Turn the INT REF FREQ control cw into the VARIABLE region. Press the LOCK CHECK button and check for beat frequencies displayed at intervals as the RF CENTER FREQUENCY is tuned through the full range of Band A, Band B and Band C.

e. *Check EXT REF FREQ IN: Phase lock from 1-5 MHz and 1-5V P to P*

Set the TYPE 191 FREQ RANGE to .75-1.6 MHz, vernier to 1, AMPLITUDE RANGE to .5-5V, AMPLITUDE to 10 and VARIABLE to CAL.

Connect TYPE 191 OUTPUT -- GR to BNC adapter -- 50 Ω cable -- 50 Ω Termination -- EXT REF FREQ IN. Connect the TYPE 184 -- HARMONIC MODULATOR RF -- MODU HARM OUT -- TYPE 491 RF INPUT A. Press the TYPE 184 20ns MARKER SELECTOR. Tune the 50 MHz signal on screen with the RF CENTER FREQUENCY control and check for phase lock by varying the FINE RF CENTER FREQ and checking that the display pauses in its movement across the screen as the TYPE 491 local oscillator locks with the external signal. Check at several frequencies between 1 MHz and 5 MHz.

25. SENSITIVITY

Measure overall system sensitivity. To measure sensitivity, set the signal source for a display of signal plus noise equal to two times noise (see Fig. 10C). Read the sensitivity from the signal generator attenuator dial. Check sensitivity as in the following table:

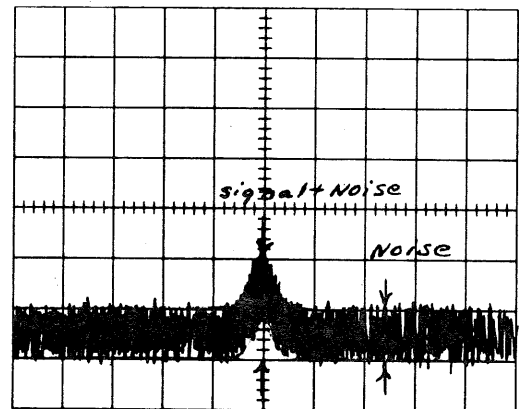

Fig. 10C

25. (cont'd)

Band	Frequency	Test Limit		Signal Source
		1 kHz Resolution	100 kHz Resolution	
Band 1	10 MHz	-100dBm, min	-80dBm, min	HP608D
	140 MHz	-100dBm, min	-80dBm, min	HP608D
	275 MHz	-100dBm, min	-80dBm, min	HP608D
Band 2	270 MHz	-110dBm, min	-90dBm, min	HP608D
	500 MHz	-110dBm, min	-90dBm, min	HP612A
	900 MHz	-110dBm, min	-90dBm, min	HP612A
Band 3	800 MHz	-105dBm, min	-85dBm, min	HP8614A
	1500 MHz	-105dBm, min	-85dBm, min	HP8614A
	2000 MHz	-105dBm, min	-85dBm, min	HP8614A
Band 4	1.5 GHz	-110dBm, min	-90dBm, min	HP8614A
	2.5 GHz	-110dBm, min	-90dBm, min	HP8614A
	4 GHz	-110dBm, min	-90dBm, min	HP8614A
Band 5	3.8 GHz	-100dBm, min	-80dBm, min	Polorad 1107
	5 GHz	-100dBm, min	-80dBm, min	Polorad 1107
	8.2 GHz	-100dBm, min	-80dBm, min	Polorad 1107
Band 6	8 GHz	- 95dBm, min	-75dBm, min	Polorad 1108
	10 GHz	- 95dBm, min	-75dBm, min	Polorad 1108
	12.4 GHz	- 95dBm, min	-75dBm, min	Polorad 1108
Band 7	12.4 GHz	- 90dBm, min	-70dBm, min	HP626A
	15 GHz	- 90dBm, min	-70dBm, min	HP626A
	18 GHz	- 90dBm, min	-70dBm, min	HP628A
Band 8	18 GHz	- 80dBm, min	-60dBm, min	HP628A
	26.5 GHz	- 80dBm, min	-60dBm, min	HP628A/HP938
	40 GHz	- 70dBm, min	-50dBm, min	HP628A/HP940

26. SPURIOUS SIGNALS

a. Check Band A spurious response:
spurious signals 2X noise, max

Place a 50 Ω Termination on RF INPUT A. Set DISPERSION RANGE to kHz/DIV and DISPERSION to 500. Set Band Selector to A and adjust the GAIN control for a display of 1 div of noise. Tune the RF CENTER FREQUENCY across the entire range and check that no spurious signal is greater than 2 div in amplitude.

a. Normally a spurious response will appear at 38 MHz, adjusting capacitors in Band A mixer will eliminate this spurious signal.

Spurious responses appearing between 100 and 150 MHz will respond to changes in mixer cable dress.

26. (cont'd)

- b. *Check Band B & C spurious response: spurious signals 2X noise, max*

Move the 50 Ω Termination to RF INPUT B. Change the DISPERSION RANGE to MHz/DIV and DISPERSION to 10. Change the Band Selector to Band B and adjust the GAIN control for a display of 1 div of noise. Tune across the entire range of Band B and check that no spurious signal is greater than 2 div in amplitude. Move the 50 Ω Termination to RF INPUT C. Change Band Selector to Band C. Measure Band C spurious signals.

- b. Spurious response at 270 MHz and sometimes 500-600 MHz may require changing the local oscillator.

27. IF ATTENUATOR

- a. *Setup*

Connect HP608D -- 50 Ω cable -- HP355C -- HP355D -- 50 Ω cable -- 50 Ω X10 attenuator -- TYPE 491 RF INPUT A. Set HP608D ATTEN to 20 and frequency controls for a 200 MHz signal. Set TYPE 491 DISPERSION RANGE to kHz/DIV and DISPERSION and GAIN for an 8 div display.

- b. *Check IF ATTENUATOR accuracy: 51dB in 1dB steps ± 0.1 dB/dB*

Progressively switch in each IF ATTENUATOR and switch out the corresponding HP355C or HP355D attenuators. Compare the amplitude in each position to the 8 div reference as in the following table:

<u>IF ATTENUATOR</u>	<u>Tolerance</u>
1dB	.9-1.1dB
2dB	1.8-2.2dB
4dB	3.6-4.4dB
8dB	7.2-8.8dB
16dB	14.4-17.6dB
20dB	18.0-22.0dB

28. GAIN CONTROL

50dB, min

With the same signal setup as in step 27 turn the TYPE 491 GAIN control full ccw. Adjust the HP355C, HP355D and HP608D ATTEN for an 8 div display. Switch in 50dB of attenuation. Turn the TYPE 491 GAIN control full cw. Check for at least 8 div of signal deflection. Remove the HP355C, HP355D and connect HP608D -- 50 Ω cable -- TYPE 491 RF INPUT A.

29. DISPLAY FUNCTIONS*a. Check LOG dynamic range: 40dB, min*

Set the TYPE 491 VERTICAL DISPLAY switch to LOG. Apply a 200 MHz signal from HP608D to RF INPUT A. Set the HP608D to -60dBm. Adjust TYPE 491 GAIN for an 8 div display of the 200 MHz signal. Set the HP608D ATTEN to -100dBm. Check that signal is still discernable.

b. Check LIN dynamic range: 26dB, min

Set the TYPE 491 VERTICAL DISPLAY switch to LIN. Adjust GAIN and HP608D ATTEN for an 8 div display. Increase the HP608D ATTEN setting 26dBm. Check that signal is still discernable.

*c. Check SQ LAW dynamic range: 13dB
total range, min*

Set the TYPE 491 VERTICAL DISPLAY switch to SQ LAW. Set the HP608D ATTEN to -50dBm and obtain an 8 div display with TYPE 491 GAIN control. Increase the HP608D ATTEN setting until the signal amplitude drops to 4 div, must be -53dBm \pm 1dBm. Increase the HP608D ATTEN setting until the signal amplitude falls to 2 div, must be -56dBm \pm 1dBm. Increase the HP608D ATTEN setting to -63dBm. Check that the signal is still discernable.

30. TO RECORDER

50mV P to P, min with
8 div display

Connect a 600 Ω load cable between TYPE 491 TO RECORDER jack and TYPE 1A1 CHANNEL 1 INPUT. Set TYPE 1A1 MODE to CHANNEL 1 and CHANNEL 1 VOLTS/CM to .01. Adjust TYPE 491 for an 8 div display. Check the test scope for 5cm deflection, minimum.

Remove the 600 Ω load cable from TYPE 491 TO RECORDER jack and TYPE 1A1 INPUT.

31. CONTRAST*a. Setup*

VERTICAL DISPLAY	LOG
DISPERSION RANGE	kHz/DIV
DISPERSION	50
RESOLUTION	coupled
INTENSIFIER	centered

Adjust the HP608D and TYPE 491 controls for an 8 div display.

b. Adjust CONTRAST contrast between upper and lower halves of screen ± 1 div

Adjust the CONTRAST so the upper half of the display is brighter than the lower half. See Fig 11C. Turn the INTENSIFIER through its range and observe a change in the relative brightness of the upper and lower halves of the display. Remove the HP608D signal from TYPE 491 RF INPUT A.

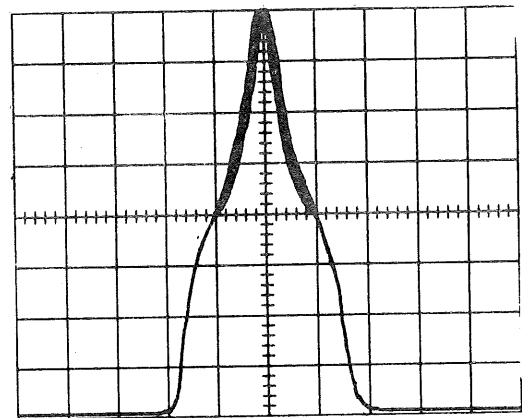

Fig. 11C

32. MIXER PEAKING*a. Setup*

Change the TYPE 491 VERTICAL DISPLAY to LIN and DISPERSION to 500. Connect the HP8614A signal to TYPE 491 RF INPUT B. Set the HP8614A frequency to 1100 MHz. Set TYPE 491 band selector to B MHz and adjust the RF CENTER FREQUENCY for a display of the 1100 MHz signal.

b. Check mixer peaking

Check that the amplitude of the display changes as MIXER PEAKING is adjusted.

c. Check SEARCH

Switch the MIXER PEAKING control to SEARCH. Move the display to the left edge of the graticule with the RF CENTER FREQUENCY control. Check that the display amplitude peaks then maintains constant amplitude as the display is moved across the graticule with RF CENTER FREQUENCY control. See Fig. 12C.

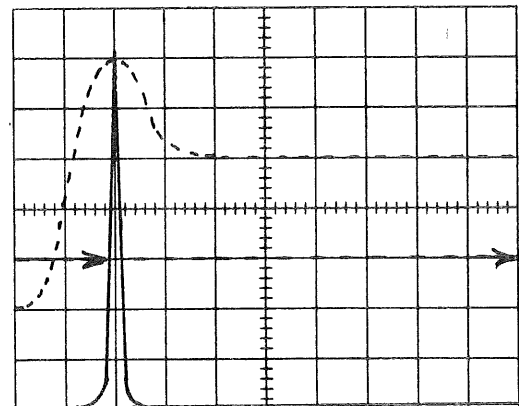

Fig. 12C

THE END