

3 The 178 test circuits for the DUT are brought out to pin jacks within this area.

Each op amp terminal is connected to a pin jack. For example, the output is labeled OUT, and consists of three pin jacks. This allows for more than one patch cord or component to be connected to the OUT jack. Similarly, the pin jacks connecting to the DUT's differential inputs are labeled +IN and -IN. Each of the inputs consists of two pin jacks. The same for the DUT supplies, the positive supply labeled V+ and negative supply labeled V-. Each consists of two pin jacks.

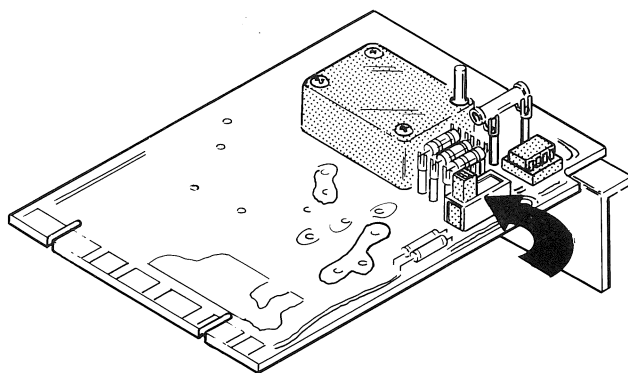

Figure 2. External Feedback Amplifier and Switch

4 An external feedback amplifier (EXT FBA) is provided for additional closed loop gain, phase shift control, and other circuit applications when needed. The EXT FBA may be added to the closed loop test configuration by the switch shown in Fig. 2. This added gain can be useful for testing low gain amplifiers, for example, in a test function such as CMRR or PSRR, where the DUT's output voltage should be held at zero volts. In these functions, the EXT FBA maintains the DUT's output closer to zero volts than would be possible if the loop gain were provided by only a low-gain DUT. If the output of a low-gain DUT is not held close to zero volts, an error signal appears at the input.

This error signal caused by low gain adds to the input signal during CMRR or PSRR and produces an erroneous measurement. With a high gain DUT, the error signal is directly reduced because a smaller signal is required at the input for a given output signal.

As a rule of thumb, this low DUT gain may cause significant measurement error when measuring CMRR and PSRR, if those parameters are 20 dB or more below the DUT gain. The EXT FBA has a gain of 40 dB, which is sufficient for most low gain, high CMRR-PSRR devices. This gain may be retailored if desired by the user.

For phase control the LM 301 is compensated with a 1000 pF capacitor for a first pole of ≤ 0.1 Hz, giving the EXT FBA a unity-gain bandwidth of ≤ 10 KHz.

The DUT will oscillate if a second pole in the system feedback loop occurs before system unity gain bandwidth is reached. Therefore, if the DUT has unity gain bandwidth much greater than the 178 gain bandwidth, the LM 301 can be used to control the system gain bandwidth. To accomplish this system gain bandwidth control, increase the size of the LM 301 compensating capacitor, C, on the Standard Op Amp Card. If the DUT has compensating terminals, compensate the DUT for unity-gain bandwidth to stop oscillations and do not use the EXT FBA.

With the EXT FBA switch in the NORM position, the EXT FBA may be used for other applications (i.e., EXT FBA can be patched into input, output, or power supply circuits to provide offset, power supply, buffer amplifier, common-mode amplifier, phase control, etc.).

5 Two variable resistors, -I Limit and +I Limit, can be set to limit the DUT supply current; see 178 manual. These variable resistors may be removed and a 1/4 watt resistor connected between the center solder pad under each variable resistor and the solder pad approximately 1/2 inch to the left of each of the variable resistors. Placing a wire between the solder pads permits the DUT supplies to provide a minimum of 150mA for each supply. 50 Ohm resistors will provide approximately 15mA.

The solder pads 1/2 inch to the left of the variable resistors are +40V unregulated supply, upper solder pad, and -40V unregulated supply, lower solder pad. The maximum available current is 175mA, but the sum of the +40V and +30 volt supply currents should not exceed 185mA (see $\diamond 11$). The DUT supply current is considered as part of the 40V supply. The same restrictions apply to the -40V supply.

$\diamond 6$ Jacks STEP and CS provide access to the 577 Step Generator and Collector Supply. EXT connects to the 178 EXT SIGNAL IN jack (178 front panel). EXT is provided to allow an external power supply, sweep generator, DMM or other test equipment to be connected into the DUT test circuits.

Kelvin sensing is provided for the collector sweep. Open the run on the back side of the board; see Fig. 3. Patch from the solder pad directly to DUT terminal.

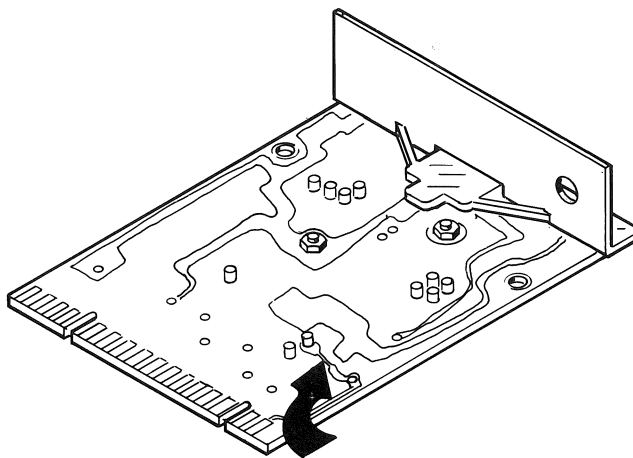

Figure 3
Breakpoint for collector Sweep Kelvin Sensing run.

The solder pad is to the left on the run.

Kelvin sensing (GND) is provided for the return path. Open the run on front side of board; see Fig. 4. Patch from the solder pad shown, directly to ground terminal of DUT.

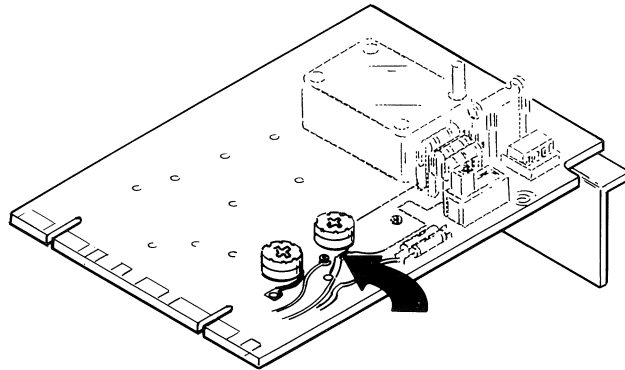

Figure 4
Breakpoint for Kelvin Sensing return path.

The solder pad is to the left on the run.

7 R_L EXT provides the means to connect an external load resistor to the DUT output. The jack at the right end of R_L EXT is connected to the OUT jack when the LOAD RESISTANCE switch on the 178 is in the EXT position. The left end of R_L EXT is grounded when FUNCTION switch is in OFFSET V, GAIN, and COLLECTOR SUPPLY I. The external load resistance is always in parallel with a 50K ohm resistor.

$-R_S$ EXT and $+R_S$ EXT provide values of source resistance other than those selected by the SOURCE RESISTANCE switch (switch to EXT position). The right ends of pin jacks $+R_S$ EXT and $-R_S$ EXT are connected to the IN jacks (with SOURCE RESISTANCE switch to 50 ohm position). If the SOURCE RESISTANCE switch is in a position other than 50 ohm, the resistance selected is between right end of R_S EXT and DUT terminal. In EXT position of SOURCE RESISTANCE switch, the left end of R_S EXT (pin jack) connects to Input terminal.

8 Sets of pin jacks are provided to patch additional components into the test circuits. Also a hole in the front panel is provided to mount a variable resistor for making offset range and other tests.

9) The 5K ohm Input terminal is used to offset the output terminal voltage for devices that require the output at some voltage other than ground. The 5K ohm input voltage must be of the opposite polarity and be one-tenth of the desired output voltage. Generally, the Step Generator can be used in the OFFSET voltage mode to provide this voltage.

The 50K ohm input terminal is used the same as the 5K ohm input. The offset voltage must be of the opposite polarity and equal to the desired voltage. The 50K ohm Input is grounded when not used to reduce noise in the 178. A run between the pin jack and ground must be opened to use this input. Resolder the run when this input is not being used. See Fig. 5 for location of solder pad and run.

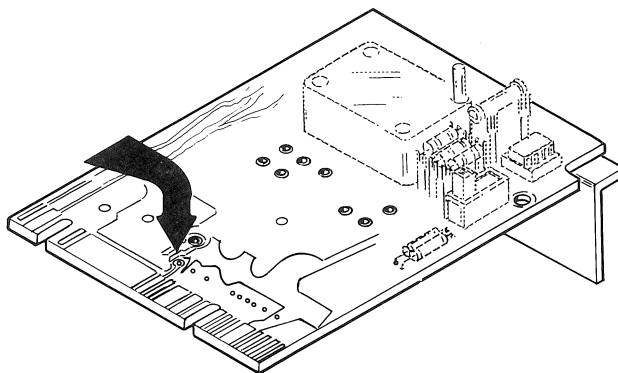

Figure 5

Breakpoint for 50K OHM INPUT run.

The pin jack is below the breakpoint.

10) S/H output provides a direct output from the sample and hold in test 2 through 11. It is connected to the top of the + Input attenuator in all tests. In test 4, MAX current output is 1mA. In all other tests, MAX current output is approx. 6mA. The voltage compliance is approx. 24 volts. Caution should be taken not to short the S/H output, as it may destroy the op-amp in the 178. The user should have a good understanding of the S/H circuit before attempting to use this circuit. See the circuit description and diagrams in the 178 manual.

11) +30 volt and -30 volt regulated supplies are provided to operate additional circuitry if needed. Maximum available current is 50mA for each supply; but the sum of the +30V and +40V supply currents should not exceed 185mA and the -30 volt and -40 volt supply currents should not exceed 185mA. See 5).

REPLACEABLE ELECTRICAL PARTS

Ckt No.	Tektronix Part No.	Serial/Model No. Eff	Discont	Name & Description	Mfr Code	Mfr Part Number
	670-2567-00			CKT CARD ASSY:STANDARD OP AMP	80009	670-2567-00
C15	281-0536-00			CAP.,FXD,CER DI:0.001UF,10%,500V	72982	301-055X5B0102K
C23	283-0110-00			CAP.,FXD,CER DI:0.005UF,+80-20%,150V	56289	19C242B
C25	283-0110-00			CAP.,FXD,CER DI:0.005UF,+80-20%,150V	56289	19C242B
CR14	152-0243-00			SEMICOND DEVICE:ZENER,0.4W,15V,5%	81483	1N965B
CR18	152-0243-00			SEMICOND DEVICE:ZENER,0.4W,15V,5%	81483	1N965B
R10	311-1568-00			RES.,VAR,NONWIR:50 OHM,20%,0.50W	73138	91A50R00M
R14	315-0104-00			RES.,FXD,CMPNSN:100K OHM,5%,0.25W	01121	CB1045
R15	315-0102-00			RES.,FXD,CMPNSN:1K OHM,5%,0.25W	01121	CB1025
R16	315-0102-00			RES.,FXD,CMPNSN:1K OHM,5%,0.25W	01121	CB1025
R20	311-1568-00			RES.,VAR,NONWIR:50 OHM,20%,0.50W	73138	91A50R00M
S30	260-1641-00			SWITCH,SLIDE:DPDT,0.5A,125VAC	10389	23-021-114
U16	156-0105-00			MICROCIRCUIT,LI:OPERATIONAL AMPLIFIER	27014	LM301AN

SCHEMATIC

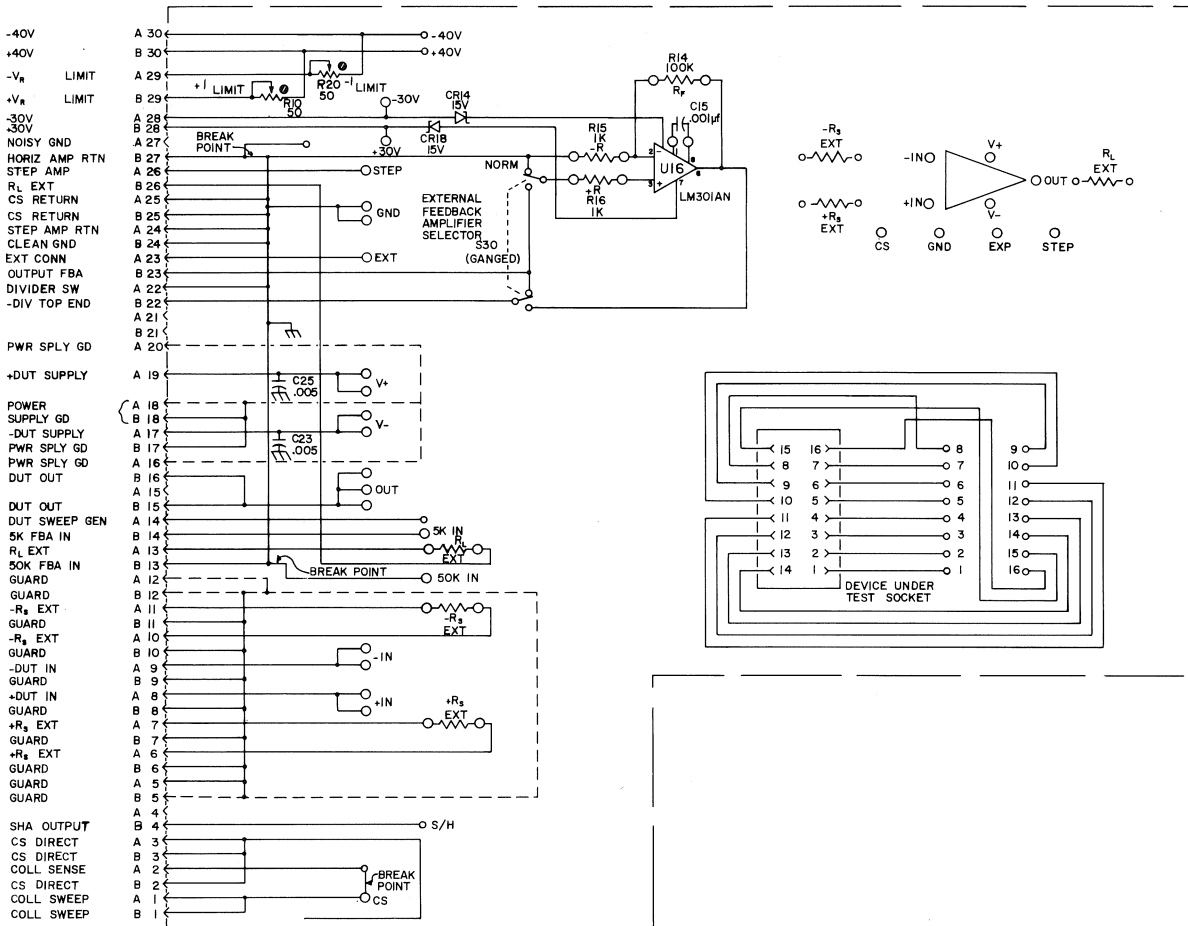

TO I78 LINER IC TEST FIXTURE

CIRCUIT BOARD LAYOUT

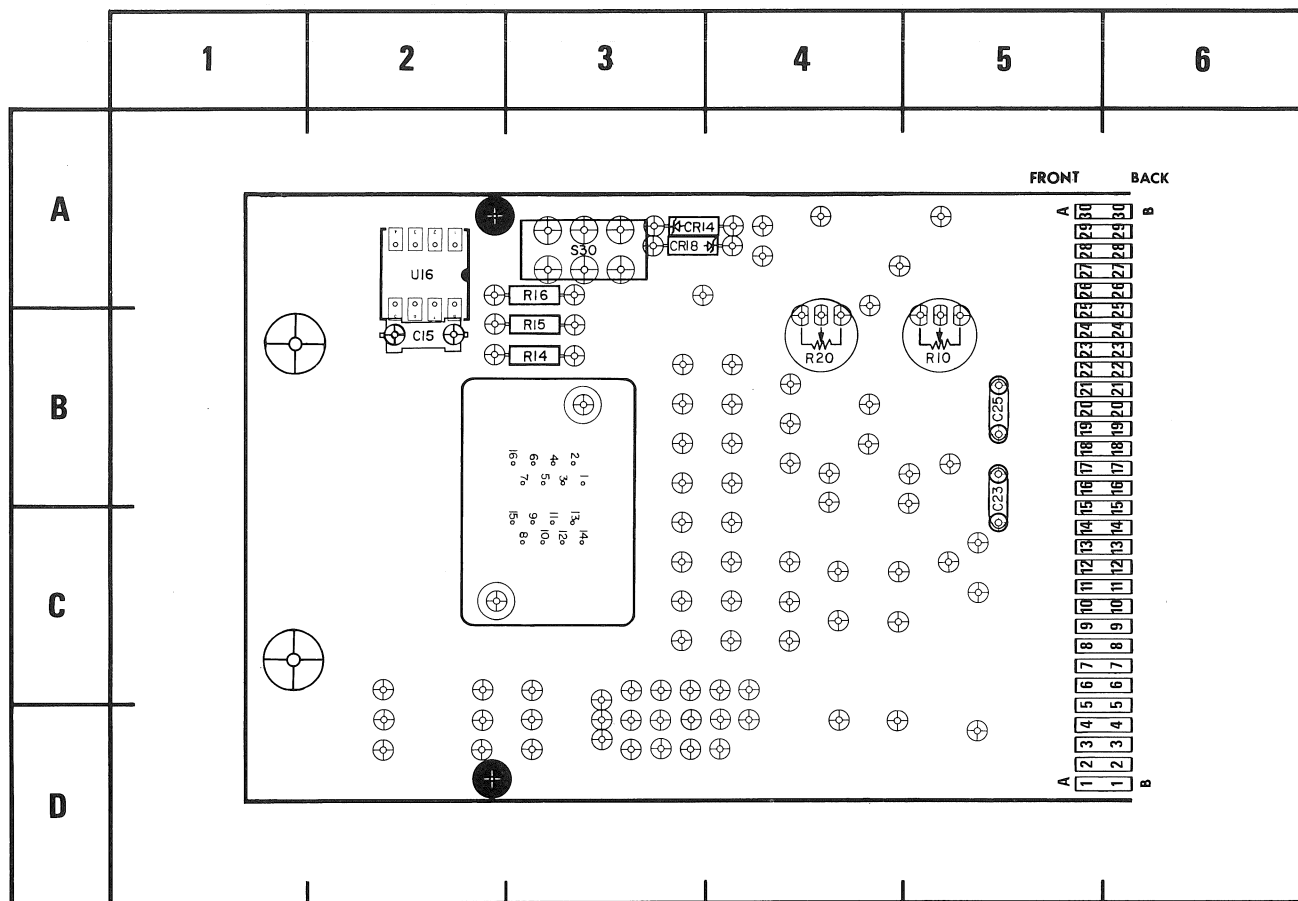

CKT NO	GRID LOC
C15	2B
C23	5C
C25	5B
CR14	3A
CR18	3A
R10	5B
R14	3B
R15	3B
R16	3A
R20	4B
S30	3A
U16	2A

EXPLODED VIEW

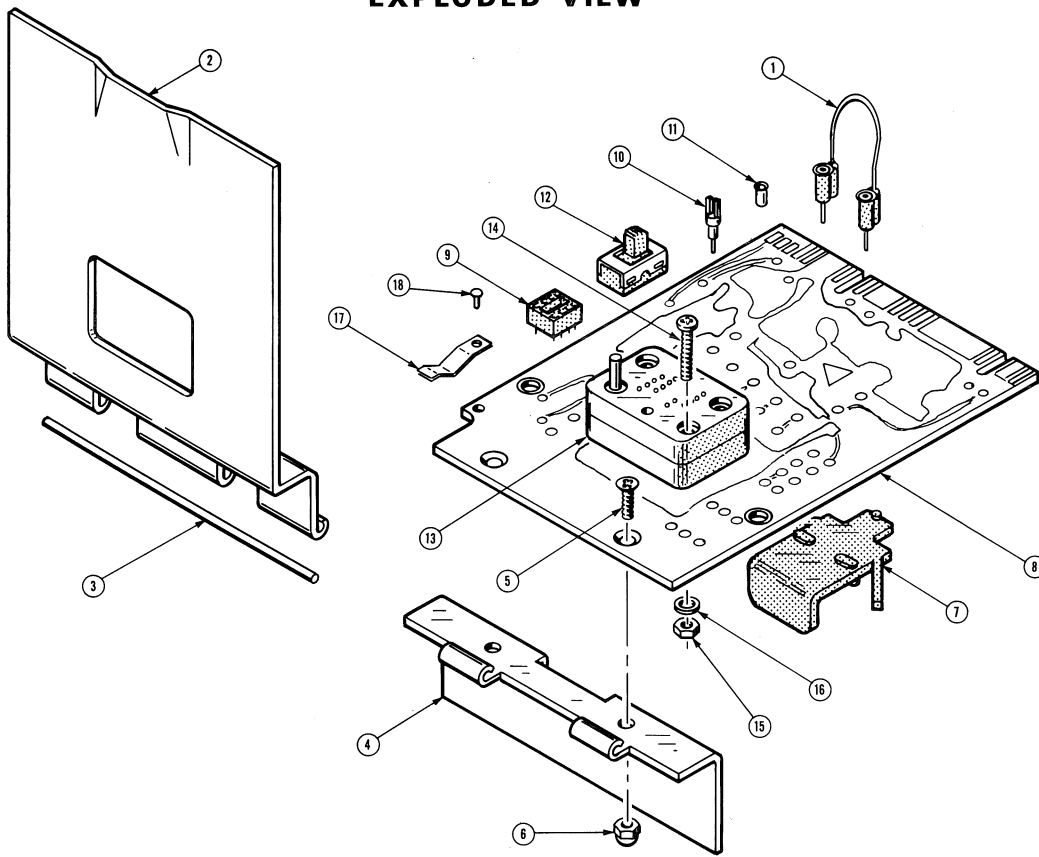

Fig. & Index No.	Tektronix Part No.	Serial/Model No. Eff	No. Dscont	Qty						Name & Description	Mfr Code	Mfr Part Number
					1	2	3	4	5			
-1	012-0200-00			10						LEAD,TEST:W/PIN JACKS,2.0" L,RED	71279	3705-1-0312
-2	200-1513-00			1						COVER,CKT BOARD:DUT (ATTACHING PARTS)	80009	200-1513-00
-3	214-1901-00			1						PIN,HINGE:0.072 DIA X 3.3 INCH L,SST - - - * - - -	80009	214-1901-00
-4	214-1883-00			1						HNG,CKT BD COV:1.063 W X 3.31 INCH LONG (ATTACHING PARTS)	80009	214-1883-00
-5	211-0101-00			2						SCREW,MACHINE:4-40 X 0.25" 100 DEG,FLH STL	83385	OBD
-6	220-0601-00			2						NUT,PLAIN,CAP:4-40 X 0.25" HEX,BRS - - - * - - -	73743	OBD
-7	367-0185-00			1						PULL,CKT CARD:GRAY PLASTIC	80009	367-0185-00
-8	-----			1						CKT CARD ASSY:STANDARD OP AMP		
-9	136-0514-00			1						SOCKET,PLUG-IN:MICROCIRCUIT,8 CONTACT	82647	C930802
-10	131-1497-00			14						CONTACT,ELEC:0.04 DIA PIN 1 END	88245	15409
-11	136-0388-00			67						SOCKET,PIN TERM:CKT BD MTG,FOR 0.04" PIN	71279	3704-1-03
-12	260-1641-00			1						SWITCH,SLIDE:DPDT,0.5A,125VAC	10389	23-021-114
-13	131-1373-00			1						CONN,RCPT,ELEC:ADAPTER,16 CONTACT (ATTACHING PARTS)	29587	699-70021-161
-14	211-0126-00			2						SCREW,MACHING:4-40 X 0.625" LONG,FILH,SST	70318	OBD
-15	210-0406-00			2						NUT,PLAIN,HEX.:4-40 X 0.188 INCH,BRS	73743	2X12161-402
-16	210-0054-00			2						WASHER,LOCK:SPLIT,0.118 ID X 0.212"OD STL - - - * - - -	83385	OBD
-17	214-1974-00			1						SPRING,GROUND:0.625 INCH LONG (ATTACHING PARTS)	80009	214-1974-00
-18	210-0702-00			1						EYELET,METALLIC:0.047 OD X 0.125 INCH LONG - - - * - - -	07707	S6127

OPTIONAL ACCESSORIES

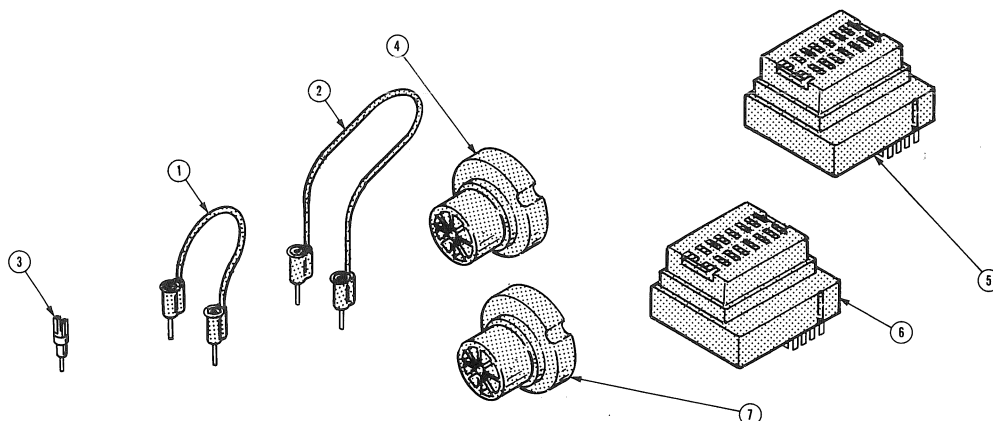

Fig. & Index No.	Tektronix Part No.	Serial/Model No. Eff Dscont	Qty								Mfr	
				1	2	3	4	5	Name & Description	Code	Mfr Part Number	
-1	012-0200-00		1							LEAD,TEST:W/PIN JACKS,2.0" L,RED	71279	3705-1-0312
-2	012-0310-00		1							LEAD,TEST:W/PIN JACKS,4.0" L,YELLOW	71279	3705-2-0314
-3	131-1497-00		1							CONTACT,ELEC:0.04 DIA PIN 1 END	88245	15409
-4	136-0441-00		1							SOCKET,PLUG-IN:XSTR,10 LEAD TO TO-5	29587	639-70021-101
-5	136-0442-00		1							SOCKET,PLUG-IN:MICROCIRCUIT,16 CONTACT	29587	029-385-03
-6	136-0443-00		1							SOCKET,PLUG-IN:MICROCIRCUIT,14 CONTACT	29587	629-70021-141
-7	136-0444-00		1							SOCKET,PLUG-IN:XSTR,10 LEAD TO TO-5	29587	639-70021-081

CROSS INDEX MFR. CODE NUMBER TO MANUFACTURER

MFR.CODE	MANUFACTURER	ADDRESS	CITY,STATE,ZIP
01121	ALLEN-BRADLEY CO.	1201 2ND ST. SOUTH	MILWAUKEE, WI 53204
07707	USM CORP., USM FASTENER DIV.	510 RIVER RD.	SHELTON, CT 06484
10389	CHICAGO SWITCH, INC.	2035 WABANSIA AVE.	CHICAGO, IL 60647
27014	NATIONAL SEMICONDUCTOR CORP.	2900 SAN YSIDRO WAY	SANTA CLARA, CA 95051
29587	BUNKER-RAMO CORP., THE, AMPHENOL INDUSTRIAL DIV.	1830 S. 54TH AVE.	CHICAGO, IL 60650
56289	SPRAGUE ELECTRIC CO.		NORTH ADAMS, MA 01247
70318	ALLMETAL SCREW PRODUCTS CO., INC.	821 STEWART AVE.	GARDEN CITY, NY 11530
71279	CAMBRIDGE THERMIONIC CORP.	445 CONCORD AVE.	CAMBRIDGE, MA 02138
72982	ERIE TECHNOLOGICAL PRODUCTS, INC.	644 W. 12TH ST.	ERIE, PA 16512
73138	BECKMAN INSTRUMENTS, INC., HELIPOT DIV.	2500 HARBOR BLVD.	FULLERTON, CA 92634
73743	FISCHER SPECIAL MFG. CO.	446 MORGAN ST.	CINCINNATI, OH 45206
80009	TEKTRONIX, INC.	P. O. BOX 500	BEAVERTON, OR 97077
81483	INTERNATIONAL RECTIFIER CORP.	9220 SUNSET BLVD.	LOS ANGELES, CA 90069
83385	CENTRAL SCREW CO.	2530 CRESCENT DR.	BROADVIEW, IL 60153
88245	LITTON SYSTEMS, INC., USECO DIV.	13536 SATICOY ST.	VAN NUYS, CA 91409
82647	TEXAS INSTRUMENTS, INC., CONTROL PRODUCTS DIV.	34 FOREST ST.	ATTLEBORO, MA 02703

