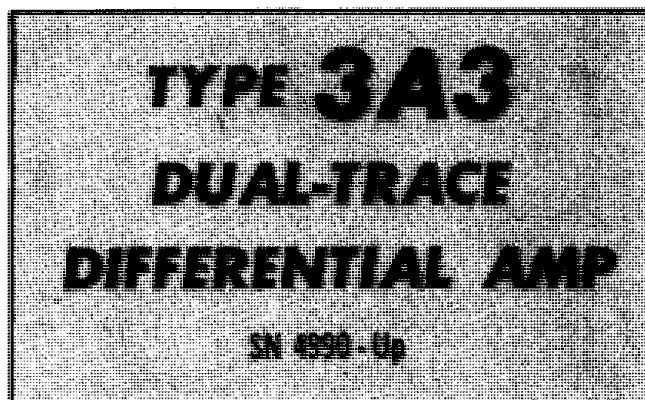


# INSTRUCTION MANUAL

Serial Number \_\_\_\_\_



*Tektronix, Inc.*

S.W. Millikan Way • P. O. Box 500 • Beaverton, Oregon 97005 • Phone 644-0161 • Cables: Tektronix

070-0787-00

369



## WARRANTY

All Tektronix instruments are warranted against defective materials and workmanship for one year. Tektronix transformers, manufactured in our plant, are warranted for the life of the instrument.

Any questions with respect to the warranty mentioned above should be taken up with your Tektronix Field Engineer.

Tektronix repair and replacement-part service is geared directly to the field, therefore all requests for repairs and replacement parts should be directed to the Tektronix Field Office or representative in your area. This procedure will assure you the fastest possible service. Please include the instrument Type and Serial or Model Number with all requests for parts or service.

Specifications and price change privileges reserved.

Copyright © 1964, new material copyright 1967, 1968, by Tektronix, Inc., Beaverton, Oregon. Printed in the United States of America. All rights reserved. Contents of this publication may not be reproduced in any form without permission of the copyright owner.



# CONTENTS

Section 1	Characteristics
Section 2	Operating Instructions
Section 3	Circuit Description
Section 4	Maintenance
Section 5	Performance Check
Section 6	Calibration
Section 7	Electrical Parts List
	Mechanical Parts List Information
Section 8	Mechanical Parts List
Section 9	Diagrams
	Mechanical Parts List Illustrations
	Accessories

Abbreviations and symbols used in this manual are based on or taken directly from IEEE Standard 260 "Standard Symbols for Units", MIL-STD-12B and other standards of the electronics industry. Change information, if any, is located at the rear of this manual.

SEE PARTS LIST FOR SEMICONDUCTOR TYPES

SERIES M MODEL 1, 2, 3



Fig. 1-1. Type 3A3 Dual-Trace Differential amplifier plug-in.

# SECTION 1

## CHARACTERISTICS

Change information, if any, affecting this section will be found at the rear of the manual.

The Type 3A3 is a Dual-Trace Differential Amplifier plug-in unit, designed to be used with Tektronix 560-series Oscilloscopes except the Type 560. The unit contains two independent high-gain differential amplifier channels. Either or both channels may be operated to produce a display. When both channels are used, a dual display is produced through alternate channel switching, or by chopping between channels during the sweep time.

In addition to the above, the Type 3A3 contains a low impedance Trigger Output circuit that provides trigger signal from either channel or a composite signal from both

channels. The selected trigger signal is coupled through the oscilloscope plug to the companion time-base unit for internal trigger operation. Jacks may be installed in the oscilloscope to provide access to this trigger signal, so it may be used to drive a slave oscilloscope or X-Y plotters.

Characteristics described in this section are valid over the stated environmental range for instruments calibrated at an ambient temperature of +20°C to +30°C. A 30 minute warm-up is required for certain temperature-dependent characteristics as noted.

### DUAL-TRACE AMPLIFIERS

Characteristic	Performance Requirement	Supplemental Information
Deflection Factor Calibrated Range	0.1 mV/div to 10 V/div, 16 steps in a 1-2-5 sequence	
Accuracy	Within $\pm 3\%$	
Uncalibrated (Variable)	Continuously variable; extends deflection factor to at least 25 V/div	$\geq 2.5:1$
GAIN Range		At least +8% to -8% from calibrated setting
Bandwidth Limit Frequency (-3 dB points)		
500 kHz	500 kHz or more	
5 kHz	Not less than 5 kHz or more than 6.25 kHz	
AC (Capacitive) Coupled Input, Lower Bandwidth Frequency	1.6 Hz within 20%	
Step Response		
Risetime (500 kHz Bandwidth)	$\leq 0.7 \mu\text{s}$	
Common-Mode Rejection Ratio		
DC (Direct) Coupled		
0.1 mV/Div to 10 mV/Div, for signals within + and - 5 V of ground	$\geq 50,000:1$ ; DC to 100 kHz	
20 mV/Div to 0.1 V/Div for signals within + and - 50 V of ground	$\geq 1,000:1$ ; 100 kHz to 500 kHz	
0.2 V/Div to 10 V/Div for signals within + and - 350 V from ground.	Equal to or adjustable to 5,000:1; DC to 1 kHz. Equal or adjustable to 1,000:1; 1 kHz to 100 kHz	
AC (Capacitive) Coupled	Equal to or adjustable to 500:1; 100 kHz to 500 kHz.	
	$\geq 500:1$ at 15 Hz	
	$\geq 2,000:1$ at 60 Hz	
Input R and C Resistance	1 M $\Omega$ within 1%	

DUAL-TRACE AMPLIFIERS (Cont.)

Characteristic	Performance Requirement	Supplemental Information
Capacitance Time Constant	47 pF within 2 pF 47 $\mu$ s within 4%. CH 1 + input and CH 1 - input; CH 2 + input and CH 2 - input matched to within 1.5%	
Input Gate Current Each Input	0°C to +35°C      +35°C to +50°C $\pm$ 100 pA or less $\pm$ 500 pA or less	
Uncompensated Input Current		$\leq$ 200 pA at 25°C (0 V at wiper arm of Input Current Zero adjustment for each channel)
Variable Balance	$\leq$ 0.2 div, shift with VARIABLE control turned from fully CW to CCW position at 10 mV/div	Adjustable to 0 using internal VAR DC BAL control
STEP ATTEN BALANCE	Adjustable for no position change while switching VOLTS/DIV selector	
POSITION Control Range		$\geq$ 6 cm above and below the graticule center line
Displayed Noise (Tangentially measured)	$\leq$ 15 $\mu$ V at 500 kHz bandwidth with 25 $\Omega$ source	A figure of noise amplitude that approximately equals twice the RMS noise value and about 1/3 of the apparent trace width
DC drift Drift with Ambient Temperature (Line Voltage Constant)	$\leq$ 50 $\mu$ V/°C	
Interchannel Isolation Attenuator Isolation	$\geq$ 10 <sup>6</sup> :1, DC to 500 kHz	
Channel Isolation	$\geq$ 10 <sup>5</sup> :1, DC to 100 kHz	
Dual Trace Isolation	$\geq$ 100:1, DC to 100 kHz	
Maximum Non-Destructive Input Voltage		
0.1 mV/Div to 10 mV/Div	350 V, DC to 1 kHz	See Fig. 1-2
20 mV/Div to 10 V/Div	350 V, DC to 500 kHz	DC (Direct) coupled; DC + peak AC.
AC (Capacitive) Coupled Input DC Rejection		600 V max when precharge circuit is used

TRIGGER OUTPUT CIRCUIT

Trig Output (Pins 11 & 12 of P-11)		
Amplitude Single Ended		2.5 V/div within 40%
Push Pull		5 V/div within 40%
Output Resistance		$\leq$ 500 $\Omega$
Bandwidth		$\geq$ 400 kHz when connected to a 2B- or 3B-series Plug-In Unit.
Chopped Mode		
Chopped Repetition Rate	200 kHz within 25%	
Chopped Line Segment	2 $\mu$ s to 3.3 $\mu$ s	
Display Factor	$\geq$ 60%	

GENERAL

Characteristic	Performance Requirement	Supplemental Information
Phase Difference Between Two Similar Type 3A3's 0.1 mV/Div to 10 mV/Div	$\leq$ 2°, DC to 100 kHz	Adjustable to zero internally

**MECHANICAL CHARACTERISTICS**

Characteristic	Information
Construction Chassis	Aluminum
Front-panel	Aluminum with anodized finish
Circuit Boards	Glass-epoxy laminate

**ENVIRONMENTAL CHARACTERISTICS**

The following environmental test limits apply when tested in accordance with the recommended test procedure. This instrument will meet the electrical performance requirements given in this section following environmental test. Complete details on environmental test procedures, including failure criteria, etc., may be obtained from Tektronix, Inc. Contact your local Tektronix Field Office or representative.

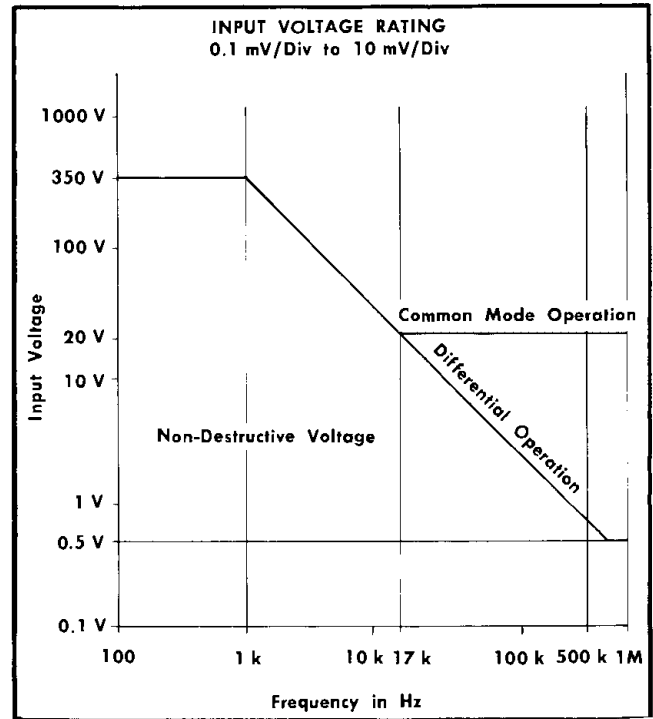


Fig. 1-2. Input Voltage rating of the Type 3A3, 0.1 mV/Div. to 10 mV/Div.

Characteristic	Operating Requirements	Supplemental Information
Temperature		
Non-operating	+4°C to +65°C	
Operating	0°C to +50°C	
Altitude		
Non-operating	To 50,000 feet	
Operating	To 15,000 feet	



# SECTION 2

## OPERATING INSTRUCTIONS

Change information, if any, affecting this section will be found at the rear of the manual.

An oscilloscope with a differential amplifier input is a device that amplifies and displays a voltage difference existing at every instant between signals applied to its two inputs. The Type 3A3 is a dual trace differential amplifier designed for use with the Type 561A, 564, or 565 Oscilloscopes. This section describes front panel control functions, first time operational procedure with some typical measurements, general information on signal input connections, common mode rejection and other subjects that pertain to differential measurement applications.

### FRONT-PANEL CONTROLS AND CONNECTORS

The following descriptions are applicable to the controls and connectors of both Input Amplifier channels. See Fig. 2-1.

+ Input Connector	Signal input connector. Labeled + to indicate that a positive voltage excursion of an applied signal will cause an upward (positive) deflection of the oscilloscope CRT trace.
— Input Connector	Signal input connector. Labeled — to indicate that a positive excursion of an applied signal will cause a downward (negative) deflection of the oscilloscope CRT trace.
AC-GND-DC	Two input selector switches for the + or — Input connectors. Switch selections are:  AC - The AC component of the signal is coupled to the amplifier input.  DC - Both AC and DC components are coupled to the amplifier input.  GND - Disconnects the input signal and internally grounds the input circuit. Presents the same load to the input signal and provides a charge path for the AC coupling capacitor so the capacitor will charge before switching the input to AC.
STEP ATTEN BALANCE	An adjustment that sets the DC balance of the amplifier. Adjusted for minimum trace shift as the VOLTS/DIV selector is switched through its range.
POSITION	Controls vertical position of the trace.
VOLTS/DIV	Volts per major graticule division. Selects the sixteen calibrated deflection factors. (VARIABLE control must be in CALIB position for correct indicated deflection factor.)

**VARIABLE** Provides continuously variable deflection factor to at least 2.5 times the setting of the VOLTS/DIV switch.

The following front-panel controls are common to both channels:

**BANDWIDTH** Simultaneously controls the upper frequency response limit of both channels. In the 500 kHz position the upper frequency response limit is 500 kHz or greater. In the 5 kHz position the upper frequency response limit is not less than 5 kHz, nor more than 6.25 kHz. The 5 kHz position attenuates high-frequency noise components when low-frequency measurements are made.

**MODE** A four-position switch that provides the following modes of operation:

CH 1: A single-trace display of the signals applied to Channel 1.

CH 2: A single-trace display of the signals applied to Channel 2.

CHOP: A dual-trace display of the signals applied to both channels. The two channels are alternately displayed in segments of about 2  $\mu$ s duration. A signal is provided for trace blanking during the switching interval.

ALT: A dual-trace display of the signals applied to both channels. The channels are alternately displayed and switching occurs at the end of each time-base sweep.

**TRIGGER** A three-position switch that permits selection of the trigger signal source. The trigger signals provide internal triggering information for the oscilloscope time-base unit.

CH 1: Signal information from Channel 1 is selected as internal triggering information.

CH 2: Signal information from Channel 2 is selected as internal triggering information.

COMP: The composite signal of both channels is selected as internal triggering information.



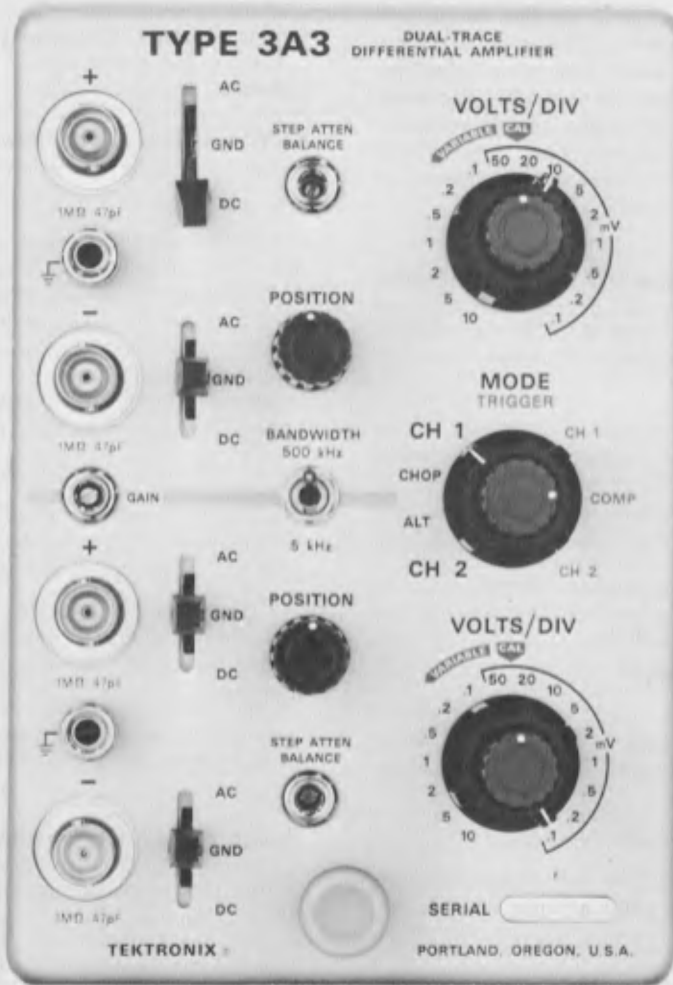


Fig. 2-1. Front panel controls and connectors.

**GAIN** A screwdriver adjustment that permits calibration of the deflection factor sensitivity. This control is the output amplifier gain control.

### FIRST TIME OPERATION

The following procedure demonstrates the function of the front panel controls and the basic adjustments that are required, on initial installation or to compensate for differences in deflection sensitivity, when the instrument is moved from one oscilloscope to another.

A Type 561A Oscilloscope and a Type 2B67 Time-Base Unit with suitable connectors and leads are used as the associated instruments for this demonstration. The Type 3A3 operating instructions and adjustments are applicable to any compatible installation where similar operating conditions can be achieved.

### Preliminary Instructions

1. Check the Type 3A3 controls for smooth mechanical operation, proper indexing and knob spacing from the front panel.
2. Install the Type 3A3 and the Time Base Unit in the Oscilloscope.
3. Apply power to the oscilloscope, set the power switch to ON and allow a warm-up period of approximately 15 minutes.
4. During the warm-up period, set the instrument controls as follows:

#### TIME BASE UNIT

##### (Type 2B67)

Time/Div	.5 ms
Variable	Calibrated (detent)
Trigger	
Source	Int
Coupling	AC
Level	Free run
Mode	Norm

#### Oscilloscope (Type 561A)

Focus, Astigmatism and Intensity	Set for a well focused, normally brilliant trace
Scale Illum	Set for graticule illumination of user's preference
CRT Cathode Selector (rear of scope)	Ext CRT Cathode

#### Type 3A3

MODE	CH 1
TRIGGER	COMP
BANDWIDTH	500 kHz

#### CH 1 & CH 2

VOLTS/DIV	10 mV
VARIABLE	CAL
POSITION	Mechanical center
AC-GND-DC (+ input switch)	GND
AC-GND-DC (- input switch)	GND

After controls have been preset, do not change settings unless instructed to do so.

### Input Signal Coupling Precautions

Before applying a signal of unknown amplitude to the input connector, set the VOLTS/DIV switch to a reasonably high deflection factor (low sensitivity). Then, if desired, switch to a lower deflection factor.

If the signal is to be AC coupled to the input, set the input Selector to the GND position before connecting the signal. This will permit the 0.1  $\mu$ F coupling capacitor to charge or discharge to the DC source voltage of the signal when it is applied to the connector. This protects associated equipment from any precharge that may be across the coupling capacitor and prevent radical shift in the display when the input selector is switched to the AC position. To use this circuit:

1. Set the AC-GND-DC switch to GND.
2. Connect the AC signal containing the DC component to the input connector and wait about one second for the coupling capacitor to charge to the DC level.
3. Set the input coupling switch to AC. The CRT display will not be deflected by the DC component, and the AC component of the signal can then be measured in the usual manner.
4. Before the signal source is disconnected from the input connector, set the AC-GND-DC switch to GND.

### Front Panel Calibration

This procedure applies to one channel. Repeat for the other channel.

1. Set the input selector to GND position and center the POSITION control.
2. Adjust the STEP ATTEN BALANCE for no trace shift as the VOLTS/DIV selector is switched from the 10 mV to .1 mV positions. Adjust the POSITION control to center the trace and repeat the STEP ATTEN BALANCE adjustment.

## FUNCTIONS OF FRONT PANEL CONTROLS AND ADJUSTMENTS

### 1. Single-ended Amplifier Operation

- a. Set the Time Base Unit, Time/Div selector to 2 ms position and the Trigger Mode to Auto.

## Operating Instructions—Type 3A3

b. Set the Type 3A3 CH 1 VOLTS/DIV selector to 10 mV position and the VARIABLE control to CAL.

c. Apply a 50 mV Calibrator signal from the Oscilloscope to the CH 1 + input connector. Switch CH 1 input selector to the DC position and adjust the POSITION control to center the display. The display should appear as a square wave approximately 5 divisions in amplitude as shown in Fig. 2-2.

d. Rotate the VARIABLE control from the CAL position to the fully counterclockwise position. The display should decrease in amplitude by a factor of at least 2.5. (Less than 2 divisions.) Return the VARIABLE control to the CAL position. See Fig. 2-3.

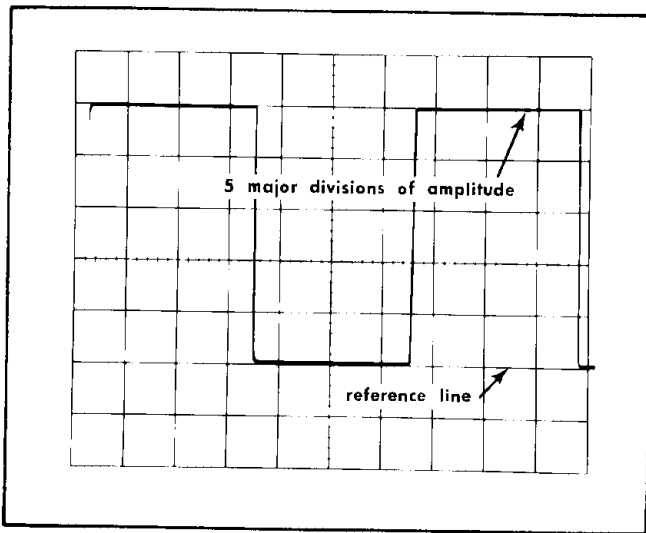


Fig. 2-2. Typical display with controls adjusted as directed in step 1.

### 2. Step Attenuator Balance

a. Set the input selectors for both channels to GND position.

b. Set the MODE switch to CH 1.

c. Adjust the STEP ATTEN BALANCE for minimum trace shift as the VOLTS/DIV switch is rotated through its range.

d. Set the MODE switch to CH 2 position and adjust channel 2 STEP ATTEN BALANCE for minimum trace shift as the CH 2 VOLTS/DIV switch is rotated through its range.

### 3. Calibration of CH 1 and CH 2 Deflection Sensitivity

a. Set the MODE switch to CH 1 and with a 50 mV signal applied to CH 1 + input connector, set CH 1 input selector to the DC position.

b. Adjust the GAIN for a 5 division Calibrator display amplitude. It may be necessary to adjust the internal CH 1 and CH 2 Gain adjustments. If this is required, proceed as follows:

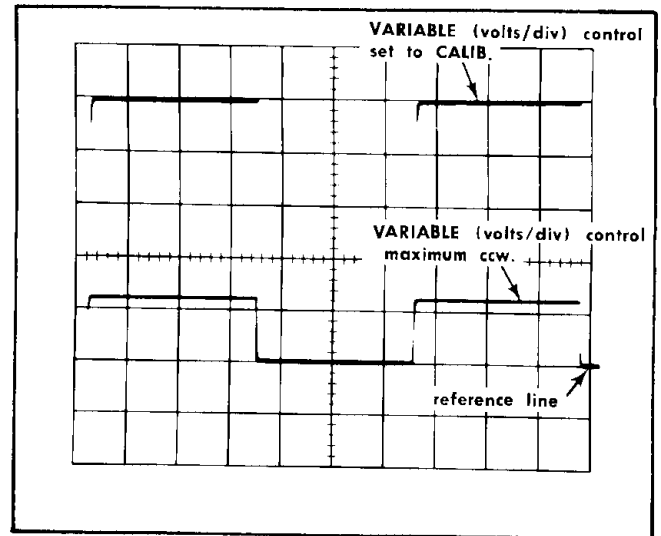


Fig. 2-3. Double-exposure photograph showing the change in deflection factor as the VARIABLE control is rotated from the CALIB position to the full ccw position.

(1) Center the GAIN adjustment. Remove the Oscilloscope left side panel, so the adjustments R175 and R375 are accessible.

(2) Adjust CH 1, Int Gain R175 (see Fig. 6-5) for a display amplitude of 5 divisions.

(3) Remove the Calibrator signal to CH 1 + input connector and apply the signal to CH 2 + input connector. Switch the CH 2 input selector to DC position and the MODE switch and TRIGGER to CH 2.

(4) Adjust CH 2 Int Gain R375 (See Fig. 6-5) for a display amplitude of 5 divisions.

(5) Replace the oscilloscope side panel.

### 4. Function of the Input Selector and the Input Connector Polarity

a. Change the Calibrator signal level to 20 mV. With the CH 2 + input selector in the DC position, adjust the POSITION control to position the bottom of the 2 division square wave on the graticule center line.

b. Switch the + input selector to AC position. Note that the display moves downward approximately 1 division.

c. Set the CH 2 + input selector to GND position. Remove the Calibrator signal from CH 2 + input connector and apply the signal to the CH 2 - input connector.

d. Switch the CH 2 - input selector to the DC position. Note the display is below the center graticule line or negative with respect to the display noted when the Calibrator signal was applied to CH 2 + input connector. Single-ended signals applied to the - input connector will produce a display that is of opposite polarity to the signals applied to the + input connector. See Fig. 2-4.

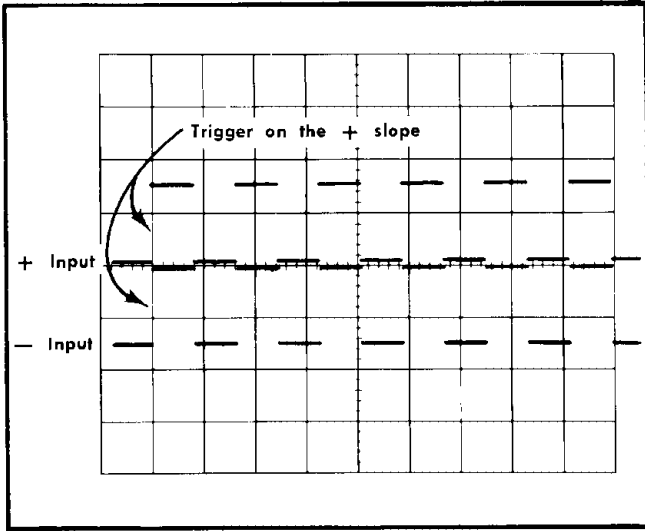


Fig. 2-4. Double exposure to illustrate that because of internal composite triggering the - input will display the signal in the same "phase" as the + input, but it will be displayed in an apparent negative region of the display.

### 5. Mode Selection

- a. Apply the Calibrator signal, via a T connector and two coaxial cables, to both CH 1 and CH 2 + input connectors.
- b. Set the CH 1 VOLTS/DIV switch to 10 mV and CH 2 VOLTS/DIV switch to 50 mV. Set both input selectors to the GND position.
- c. With the MODE switch in CH 2 position, adjust the POSITION control to position the display in the lower half of the graticule area. Switch the MODE switch to CH 1, and position the CH 1 display to the upper half of the graticule area.
- d. Switch the MODE selector to CHOP and change the Time/Div selector to 2  $\mu$ s position. The display should ap-

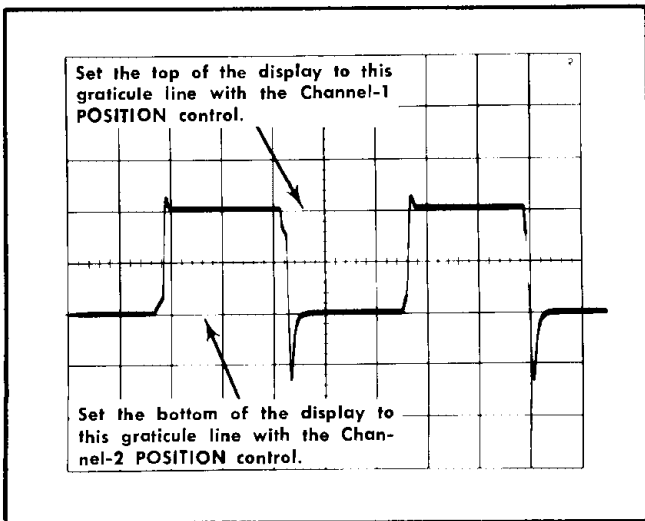


Fig. 2-5. Photograph of a typical CRT display with the controls set as directed in step 5.

pear as illustrated in Fig. 2-5. Change the CRT Cathode Selector switch on the oscilloscope to the Chopped Blanking position. Switching transients (rising and falling portions of the display) will be blanked out and the display should approximate the illustration of Fig. 2-6. Rotate the Time/Div switch through its full range, note that at sweep rates  $\geq 50 \mu$ s/div the display appears as a square wave with alternate segments of two traces presented during the sweep. At sweep rates below 50  $\mu$ s/div the display appears as two complete traces.

- e. Change the MODE switch to ALTER position and again rotate the Time/Div switch through its range. Note that at sweep rates below 10 ms/div the alternate sweeps for each channel are visible with switching occurring at the end of each sweep. At the slower sweep rates it is best to reduce the intensity level to avoid burning the CRT phosphor.
- f. Set the Time/Div selector to 2 ms position. Switch CH 1 and CH 2 + input selectors to DC. Note the dual display.
- g. Set the MODE switch to CHOP and note the dual display. Switch the Oscilloscope CRT Cathode Selector to both positions and note the effect of chopped blanking on the display.

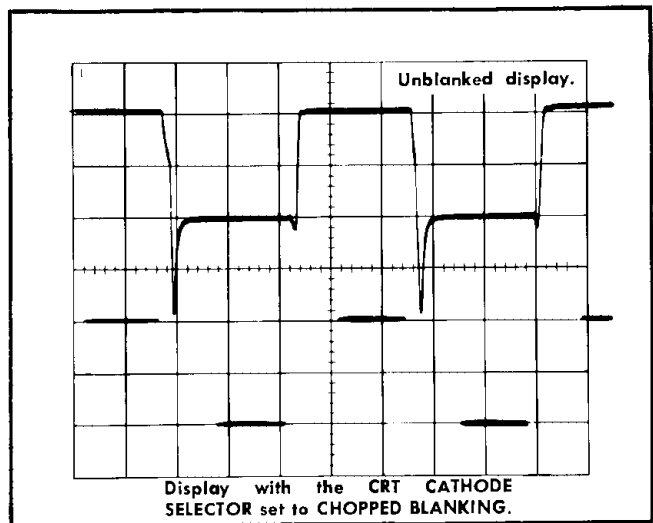


Fig. 2-6. Double-exposure photograph showing the effect of setting the CRT CATHODE SELECTOR to CHOPPED BLANKING. (The waveform was moved from the upper to the lower portion of the graticule area for the second exposure.)

### 6. Trigger Selection

- a. Set the MODE switch to CH 1, and the + input selectors for CH 1 and CH 2 in the DC position. Set the TRIGGER switch to CH 1.
- b. Adjust the Trigger Level control for a stable triggered display.
- c. Switch the TRIGGER selector to COMP. Readjust the Trigger Level control if necessary to obtain a stable display. The display should then remain locked.
- d. Switch the MODE selector to CH 2 and the TRIGGER switch to CH 2. Adjust the Trigger Level control if required to trigger the display.

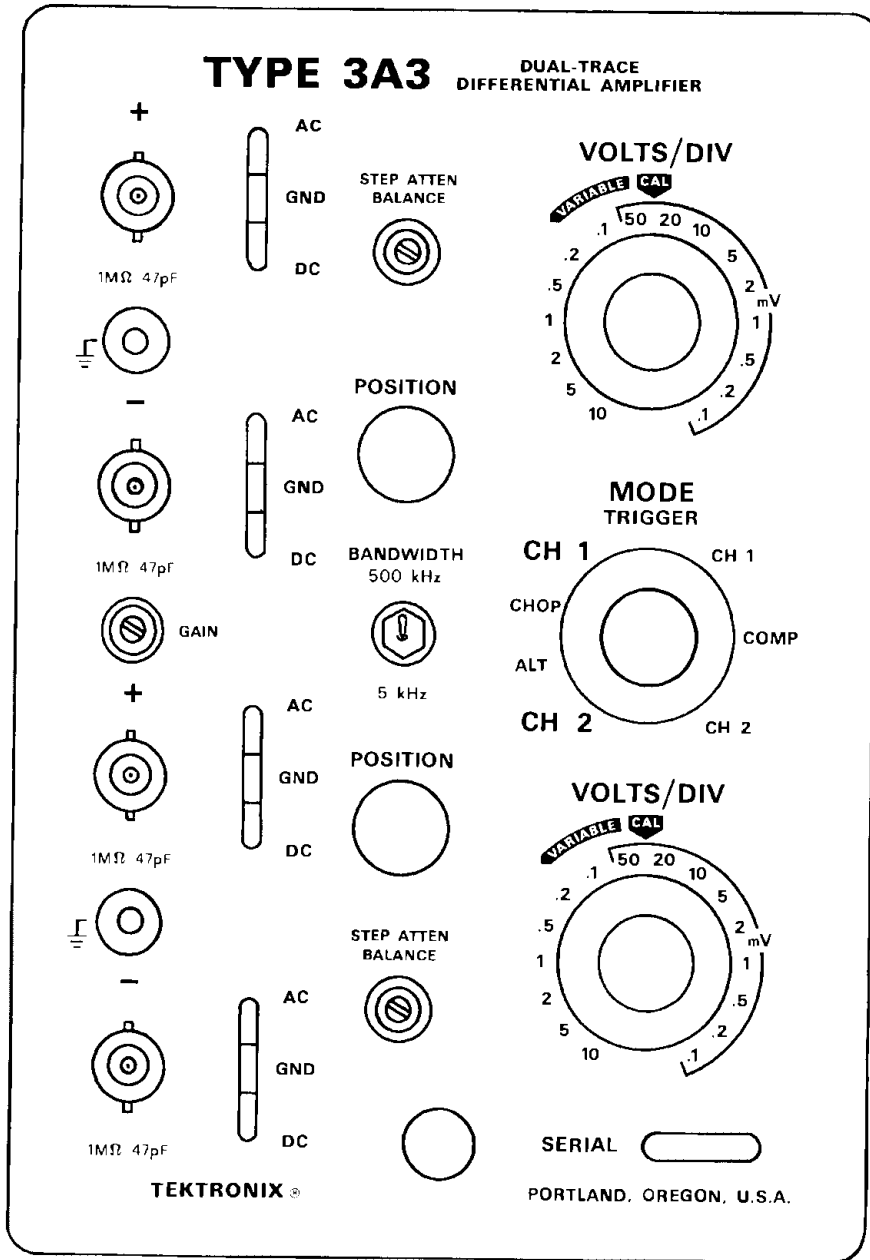


Fig. 2-7. Type 3A3 control setup chart.

e. Switch the MODE selector to CH 1. The CH 1 display should appear as a stable triggered display. Switch the CH 1 + input selector to GND or remove the input signal to CH 1. The display should disappear, but the trace should remain. This indicates that CH 2 signal is triggering the sweep for CH 1 mode of operation.

Remove all signal cables and connections and return all input selectors to GND. Set the MODE switch to CH 1 and the TRIGGER selector to CH 1.

## GENERAL OPERATING INFORMATION

### NOTE

For the remainder of this section, it is assumed the Type 3A3 is installed in a Type 561A Oscilloscope with a Type 2B67 Time-Base Unit.

### Control Setup Chart

Fig. 2-7 shows the front panel of the Type 3A3. This picture may be reproduced and used as a test-setup record for special measurements, applications or procedures, or it may be used as a training aid for familiarization with this instrument.

### Common-Mode Rejection

The definition of the term "differential amplifier" implies a rejection of equal amplitude signals applied coincidentally to two inputs. This implication is correct. However, the degree of rejection depends primarily on the symmetry of the amplifier inputs. The amount of difference signal from a particular amplifier is documented with a mathematical relationship that is called the common-mode rejection ratio (CMRR). This ratio and associated terms are defined as follows:

**Common-Mode:** Refers to signals that are identical with respect to both amplitude and time.

**Common-Mode Rejection:** The ability of a differential amplifier to reject common-mode signals.

**Common-Mode Rejection Ratio (CMRR):** The ratio of the amplitude of the common-mode input signal to the difference (or differential) input signal which would produce the same deflection on the CRT screen.

### NOTE

Since the differential amplifier is part of an oscilloscope, the signal used to calculate the CMRR is measured from the CRT screen in accordance with the division switch setting. Thus when a differential amplifier is driven by 5.0 volts of common-mode signal and produces an output corresponding to a 0.005-volt differential input, the amplifier then has a CMRR of  $5/0.005$  or 1000:1.

### Amplitude and Common-Mode Rejection

In the text to follow, the term maximum common-mode input voltage means the maximum voltage that will not over-

drive the amplifier. This should not be confused with the maximum nondestructive input voltage, which is related to the breakdown limits of the amplifier components.

### Factors Which Affect CMRR

**Frequency.** Since the common-mode output voltage is a factor of phase difference as well as gain between channels, the frequency of the input common-mode signal has a definite bearing on the CMRR. Generally, as the frequency of the input signal increases the CMRR is more difficult to maintain.

**Source Impedance.** The specified CMRR assumes that the points being measured have identical source impedance. The source impedance and the amplifier input impedance form an RC divider which determines the portion of the signal that appears across the amplifier input, and the apparent effect on CMRR. See Fig. 2-8.

**Signal Transporting Leads.** A principal requirement for maximum CMRR is that the signals must arrive at the two inputs in precisely the same phase and amplitude. Slight differences in attenuation factors, or phase shift between two input attenuators may reduce the CMRR 20% or more.

Attenuator probes extend the usable voltage range of a differential amplifier by reducing the input signal level below the maximum common-mode input voltage. However, the probes may cause a reduction in the apparent CMRR due to component value differences within the probes. For example, Fig. 2-9 illustrates the change in CMRR (apparent) due to  $10\times$  probes that are within 1%, 2% and 3% of their attenuation value.

In measurements where attenuator probes must be used because of high voltage levels, and at the same time a high (above 100:1) CMRR must be maintained, the Tektronix P6023 Probe is recommended. This is a  $10\times$  low capacitance probe with variable attenuator ratio that is adjustable over a  $\pm 2.5\%$  range.

**Ground Connections.** Proper grounding reduces signals generated from ground loop currents. It is best to electrically connect the probe or signal lead shields together at the probe body or signal source, but not to the instrument ground. See Fig. 2-10.

### Differential Amplifier Applications

In differential measurements each input of the amplifier acts as a reference for the other. Chassis ground connections are valuable primarily for safety reasons. (The term differential input is synonymous with floating input).

In applications such as examining a signal superimposed on some DC level with DC coupling, an offset voltage may be applied to the other input of the differential amplifier to slide the signal back on the CRT screen. For example; if a differential amplifier is set for a vertical sensitivity of 10 mV/cm (trace on-screen) and a DC voltage of 1 V is applied to the + input, the trace will be deflected upward off screen. If a +1 V DC voltage is now applied to the - input, the trace will return on screen, or the signal will slide back on-screen as a result of the voltage (slide-back voltage) applied to the - input. The DC voltage applied to the -

## Operating Instructions—Type 3A3

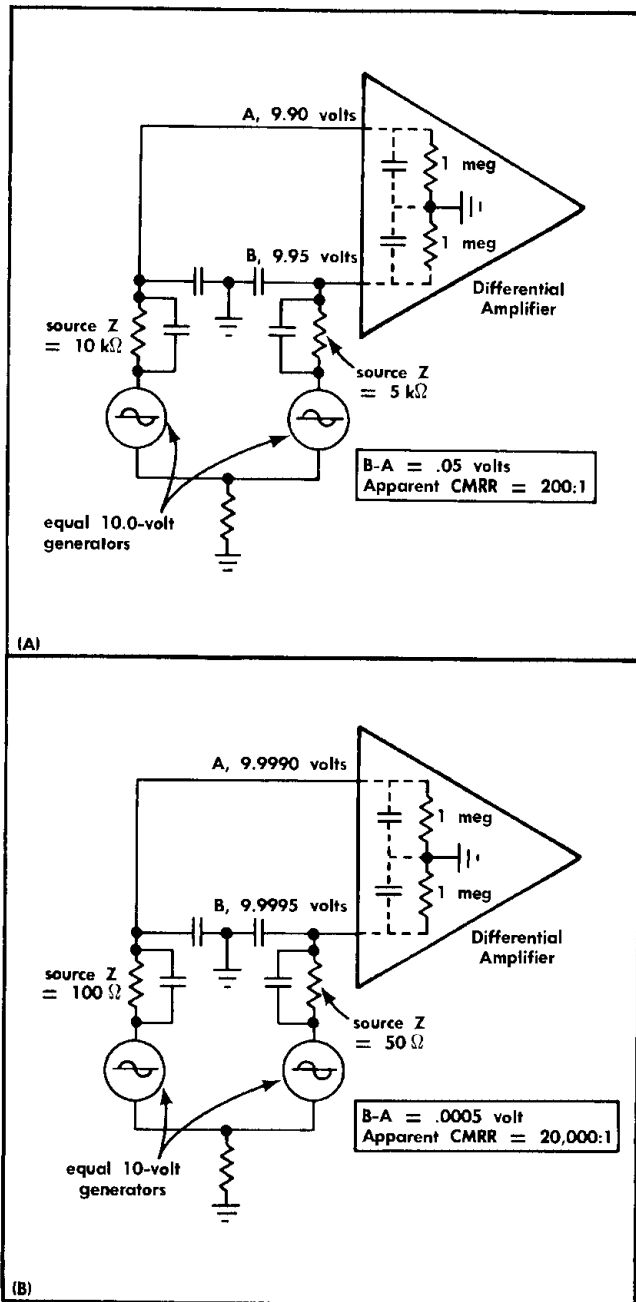


Fig. 2-8. (A) Relationship of test-point source impedance to the amplifier-input impedance, and the apparent CMRR caused by large difference between test-point impedances. (B) Relationship of source impedance to amplifier input impedance and the apparent CMRR caused by low impedance test points.

input is in effect common-mode with that of the + input; thus, both are rejected by the amplifier.

### Signal Input Connections

Table 2-1 lists a number of methods for connecting to the signal source, with the advantages, the limitations of each method. Method 1 can be used to connect the instrument to a high-level low frequency signal source, if it is monitored at some low impedance point. It becomes increasingly im-

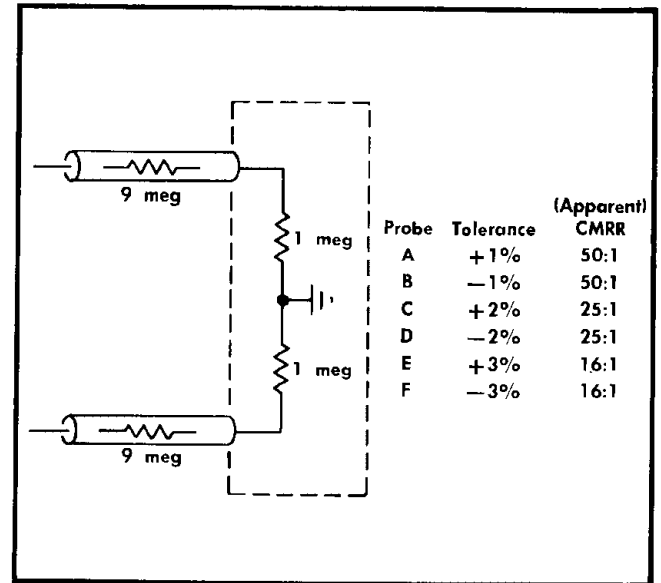


Fig. 2-9. Simplified input circuit and table to show the change in CMRR (apparent) due to 10X probes that are within 1, 2, and 3% of their attenuation values (with matched 1 meg resistors).

portant, however, to use shielded signal cables when any of these factors are missing. In all cases, the leads should be kept as short as possible.

When making single-ended input measurements (conventional amplifier operation), establish a common ground connection between the device under test and the Type 3A3. Normally the shield of a coaxial cable serves this purpose.

Differential measurements require no common ground connection; however, voltages on the test point with respect to the chassis potential of the Type 3A3 should be limited to the levels listed in Section 1, under common-mode rejection characteristics. Higher signal levels will degrade the common-mode rejection ratio. The DC plus peak AC input voltage rating of the unit should not be exceeded.

Outside influences such as interference signals and magnetic fields can be minimized by using the same type of signal transporting leads for each input and connecting the shields at the signal source end. Where an interfering magnetic field can not be avoided, the two leads should be equally exposed to the field, by taping or twisting them together throughout their length. Low-frequency measurements can be similarly protected by using a shielded cable which contains a twisted pair of conductors.

Consider the signal source loading and the resulting change in the source operating characteristics due to the input circuit of the Type 3A3 and the signal cables. The circuit at the input connectors can normally be represented by approximately  $1\text{ M}\Omega$  resistance to ground paralleled by approximately  $47\text{ pF}$ . A few feet of shielded cable may increase the parallel capacitance to  $60\text{ pF}$  or more, which could be excessive in many situations. To minimize these effects, it may be advisable to use an attenuator probe.

Attenuator probes not only decrease the resistance and capacitance loading of the signal source, but also extend the measurement range of the Type 3A3 to higher voltages.



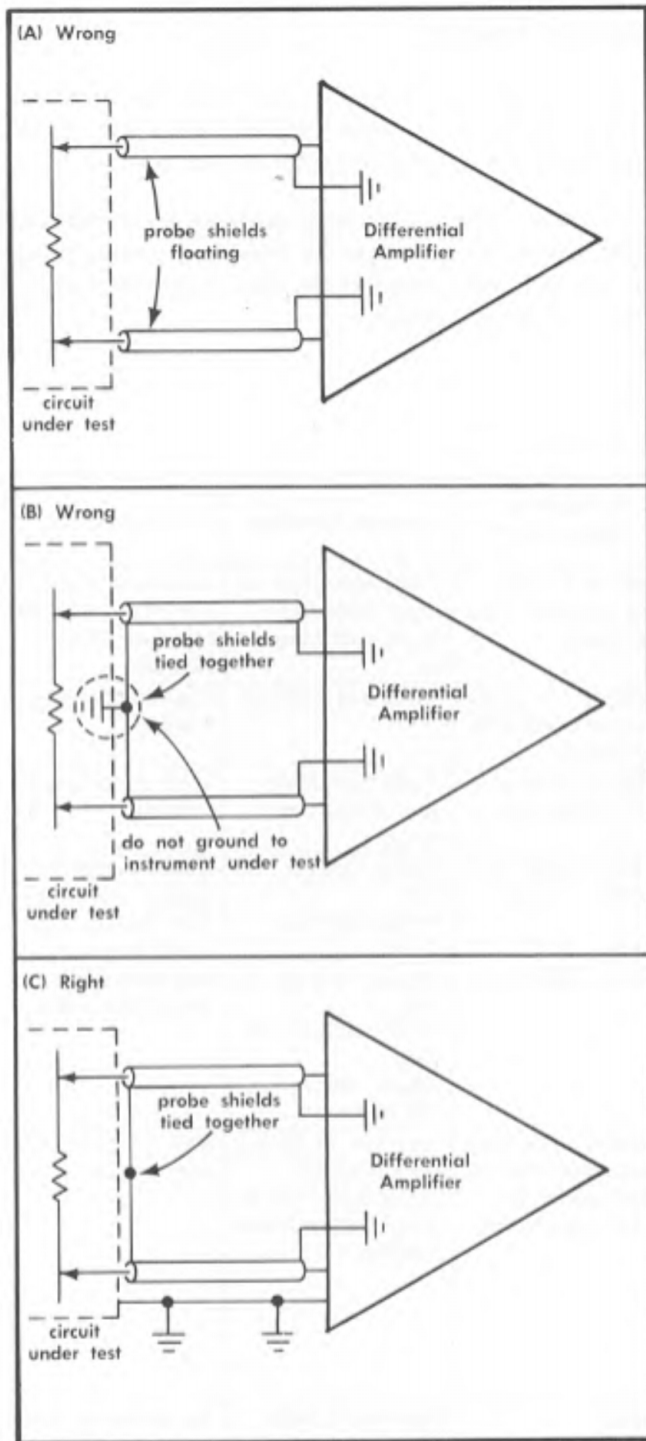


Fig. 2-10. Connecting a differential amplifier across a circuit. The ground shown in (C) is not essential to the measurement.

Attenuator probes and their effect were discussed previously in this section. Passive attenuator probes having attenuation factors of  $10\times$ ,  $100\times$  and  $1000\times$ , as well as other special-purpose types are available through your Tektronix Field Engineer or Field Office.

Some measurement situations require a high-resistance input to the Type 3A3 with very little source loading or signal

attenuation. This problem may be solved by using a probe such as the P6012 or using the floating input provision of the Type 3A3.

The floating input provision provides a substantially higher input resistance than the 1 megohm of the input gate return resistor. The input circuits can be modified by removing a wire link from the attenuator etched wiring board (see Fig. 2-11). When the wire link is removed, the 1 megohm gate return resistor is disconnected, and only DC-coupled signals (using the 0.1 mVOLTS to 10 mVOLTS/DIV deflection factors) can be accurately measured. The signal source circuit must provide a DC current path for any input gate current.

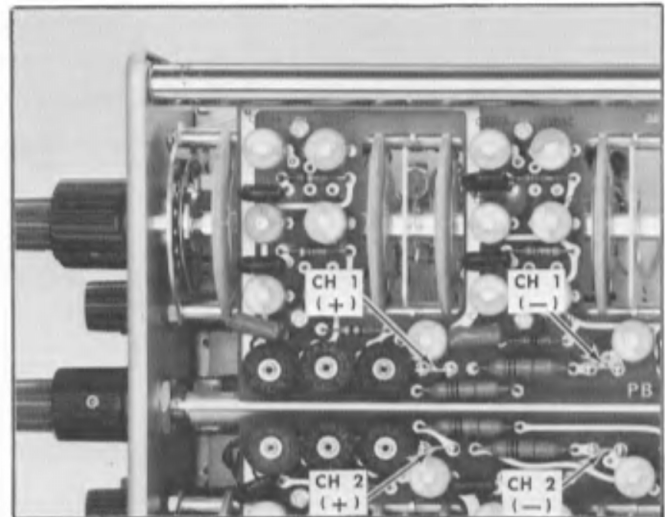


Fig. 2-11. Location of removable wire links for floating input provision.

Input current is compensated to less than 100 pA, but may be higher at temperatures above 40°C. With the wire links removed for the floating input provision, the amount of input current and the DC resistance of the circuit under test may become important considerations where small signals are of concern. For example; a 100 pA leakage current through a 1 megohm source resistance will produce a 0.1 mV DC offset voltage.

With high frequency applications where the upper frequency response characteristics of the Type 3A3 are critical to the measurement, the signal source impedance becomes an important consideration, since the various shunt capacitances between the source and the input must charge and discharge through this impedance.

### Input Capacitor Coupling

Connecting the amplifier to a signal voltage above the capacity of the amplifier may cause the trace to be deflected off the screen. When measuring some unknown DC voltage, use a higher deflection factor or lower sensitivity setting before connecting the amplifier input to the voltage source, then switch down to a higher sensitivity setting. The AC component of signals containing both AC and DC components, can be measured by using the precharging circuit incorpo-

## Operating Instructions—Type 3A3

rated in the unit. This circuit will pre-charge the 0.1  $\mu\text{F}$  coupling capacitor to the DC source voltage when the AC-GND-DC input coupling switch is set to GND. The procedure is as follows:

1. Set the AC-GND-DC input coupling switch to GND position, then connect the input to the circuit under test.
2. Wait a moment for the coupling capacitor to charge.
3. Set the input coupling switch to AC. The display will remain on the screen and the AC component can be measured in the usual manner.

## Display Polarity

Single-ended signals applied to the + input connector produce a display in phase with the input signal. Signals applied to the — input connector will be inverted.

A similar polarity relationship exists for differentially applied signals, but pertains to the direction of voltage change at one input with respect to the other, rather than with respect to chassis potential.

**TABLE 2-1**  
Signal Coupling Methods

Method of Coupling the Signal	Advantages	Limitations	Accessories Required	Source Loading	Precautions
1. Open (unshielded) test leads.	Simplicity.	Subject to stray pickup.	BNC to banana jack adapter. Two test leads.	1 M $\Omega$ and 47 pF at input, plus test leads and adapter.	Use short leads. Position leads for minimum stray pickup.
2. 1 $\times$ , 1 M $\Omega$ probe.	Full sensitivity. Total Type 3A3/oscilloscope bandwidth.	High capacitance of cable.	P6028 is 1 $\times$ probe equipped with BNC connector.	1 M $\Omega$ and $\approx$ 87 pF.	High capacitance loading.
3. Unterminated coaxial cable.	Full sensitivity.	High capacitance.	Coaxial cable with BNC connectors.	1 M $\Omega$ and 47 pF plus cable capacitance.	High capacitance loading.
4. 10 $\times$ (8 M $\Omega$ ) probe for P6023; 10 M $\Omega$ for others. 100 $\times$ , 10 M $\Omega$ probe. 1000 $\times$ , 10 M $\Omega$ probe.	Reduced resistive and capacitive loading, full Type 3A3/Oscilloscope bandwidth. Retain high CMRR by using two P6023 Probes for differential operation.	10 $\times$ attenuation. 100 $\times$ attenuation. 1000 $\times$ attenuation. Increased display noise.	P6006, P6008 and P6023 are 10 $\times$ . P6007: 100 $\times$ P6015: 1000 $\times$	P6006: $\approx$ 8 pF, 10 M $\Omega$ . P6008: $\approx$ 7.5 pF, 10 M $\Omega$ . P6023: $\approx$ 12 pF, 10 M $\Omega$ . P6007: $\approx$ 2 pF, 10 M $\Omega$ . P6015: $\approx$ 2.7 pF, 100 M $\Omega$ .	Check probe frequency compensation. Use square-wave frequency less than 5 kHz, preferably 1 kHz.
5. Current transformer CT-2 and P6041 probe. Terminated in 50 $\Omega$ at the Type 3A3. Bandwidth that of Oscilloscope.	Current transformer can be permanent part of test circuit. Less than 2.2 pF to test circuit chassis. Measure signal currents in transistor circuits. Pulse current rating: 100 A peak.	Low frequency limit: $\approx$ 1.2 kHz. RMS current rating: 2.5 A. Deflection factor: 1 mV/mA.	Nothing extra (Perhaps additional coaxial cable) for either transformer.	Insertion Z: 0.04 $\Omega$ paralleled by about 5 $\mu\text{H}$ . Up to 2.2 pF capacitance loading.	Not a quick-connect device.
6. P6019 or P6020 Current Probe and Type 134 Amplifier. Bandwidth that of Type 3A3/Oscilloscope.	Measure signal currents. AC current saturation rating: 15 A peak to peak.	Low frequency limit: $\approx$ 30 Hz. Basic deflection factor: 50 mV/mA.	None.	Insertion Z with step function applied: 0.04 $\Omega$ after 0.1 $\mu\text{s}$ .	To preserve low-frequency response, avoid scratching probe current transformer core.

## Voltage Comparison Measurements

In some applications it may be necessary to establish a set of deflection factors other than those indicated by the VOLTS/DIV switch. This is useful for comparing signals to a reference voltage amplitude. To establish a new set of de-

flection factors based upon a specific reference amplitude, proceed as follows:

1. Apply the reference signal of known amplitude to either INPUT connector. Set the MODE switch to display the channel used. Using the VOLTS/DIV switch and the VARIABLE

control, adjust the display for an exact number of divisions. Do not move the VARIABLE VOLTS/DIV control after obtaining the desired deflection.

2. Divide the amplitude of the reference signal (volts) by the product of the deflection in divisions established in step 1) and the VOLTS/DIV switch setting. This is the Deflection Conversion Factor.

$$\text{Deflection Conversion Factor} = \frac{\text{reference signal amplitude (volts)}}{\text{deflection (divisions)} \times \text{VOLTS/DIV setting}}$$

3. To establish an Adjusted Deflection Factor at any setting of the VOLTS/DIV switch, multiply the VOLTS/DIV switch setting by the Deflection Conversion Factor established in Step 2.

$$\text{Adjusted Deflection Factor} = \text{VOLTS/DIV Setting} \times \text{Deflection Conversion Factor}$$

This adjusted Deflection Factor applies only to the channel used and is correct only if the VARIABLE VOLTS/DIV control is not moved from the position set in step 1.

4. To determine the peak to peak amplitude of a signal compared to a reference, disconnect the reference and apply the signal to the input connector.

5. Set the VOLTS/DIV switch to a setting that will provide sufficient deflection to make measurement. Do not readjust the VARIABLE VOLTS/DIV control.

6. Measure the vertical deflection in divisions and determine the amplitude by the following formula:

$$\text{Signal Amplitude} = \text{Adjusted Deflection Factor} \times \text{Deflection (divisions)}$$

Example. Assume a reference signal amplitude of 30 volts, a VOLTS/DIV setting of 5 and a deflection of 4 divisions. Substituting these values in the Deflection Conversion Factor formula (step 2):

$$\text{Deflection Conversion Factor} = \frac{30}{4 \times 5} = 1.5$$

Then, with a VOLTS/DIV switch setting of 10, the Adjusted Deflection Factor (step 3) is:

$$\text{Adjusted Deflection Factor} = 10 \times 1.5 = 15 \text{ volts/division}$$

To determine the peak to peak amplitude of an applied signal which produces a vertical deflection of 5 divisions, use the Signal Amplitude formula (step 6):

$$\text{Signal Amplitude} = 15 \times 5 = 75 \text{ volts}$$

## Differential Operation

Differential voltage measurements are made by applying the signals to both the + and - input connectors. Either channel may be used. Both coupling switches should be set to the same positions; AC or DC, depending on the coupling desired. A differential amplifier amplifies only the difference

voltage; the common mode signal is rejected by an amount equal to the CMRR. See Fig. 2-12.

Some common differential applications include:

(1) Measurement of the difference amplitude between signals of the same frequency and phase.

(2) Measurement of any DC voltage difference between two test points in a circuit.

(3) Elimination of a DC voltage from a composite signal without the use of a DC blocking capacitor, when low-frequency response is a consideration.

(4) Elimination of a particular frequency or waveform from a composite waveform.

(5) Use of the differential technique instead of single-ended to measure a comparatively small signal in the presence of comparatively high level interference signals.

With the (+) and (-) input circuits in differential configuration, the two circuits provide the reference for each other. Chassis ground is not the reference for the measurement. When using the differential technique, observe the Maximum Common Mode Amplitudes listed in Section 1 and establish a common ground for safety reasons.

The common-mode rejection ratio (CMRR) of the Type 3A3 is greater than 50,000:1 for the .1 mV to 10 mV sensitivity range when signals from DC to 100 kHz are DC coupled to the inputs. Therefore, interfering signals that may be prevalent on single-ended instruments, such as AC line frequency hum, can be effectively rejected through differential operation. For example: Analysis of a 1 mV peak to peak signal which is modulated by a 1.0 volt 60 Hz signal would be impractical with single-ended operation; however, if the 60 Hz signal is common-mode to a differential input, an amplifier sensitivity of 1 mV/DIV will provide 1 major division of desired signal modulated by less than 1/10,000 of the 1.0 volt 60 Hz signal or less than 0.1 minor division of Common-mode signal.

The P6023 probe with its adjustable R and C attenuation factors provides minimum probe reduction of the CMRR.

The following adjustment procedure is recommended to prepare P6023 probes for differential measurements:

1. Connect one probe for DC-coupled single-ended input operation. Obtain a triggered display of an appropriate square-wave signal such as that from the oscilloscope amplitude calibrator. Adjust the probe DC Atten Calibration control for correct deflection sensitivity; then use the AC Coarse Comp and AC Fine Adjust control to compensate the probe for proper square-wave response.

2. Connect a second probe for DC-coupled operation. Apply the square-wave signal to both probes at 100 volts peak to peak. Obtain a free-running sweep and adjust the DC Atten Calibration control of the second probe for maximum low frequency cancellation. This is indicated by the elimination of the two-trace appearance, resulting in one trace of minimum width.

3. Adjust the AC Coarse Comp and AC Comp Fine Adjust controls of the second probe to minimize the amplitude of the differentiated pulses on the trace.

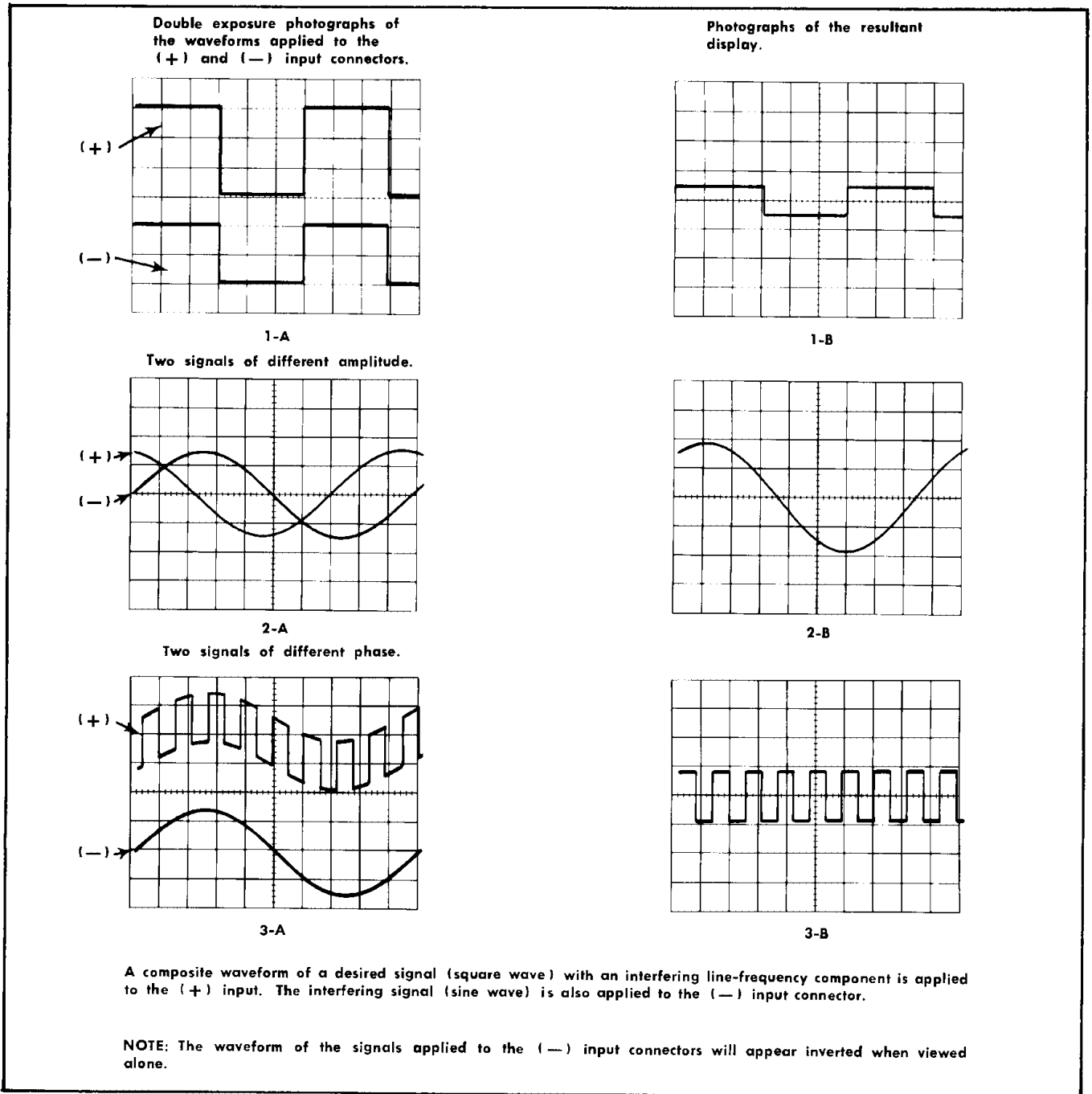


Fig. 2-12. Three examples of differential applications.

4. The probes are now matched and ready for use at any sensitivity which employs the particular input attenuator used during steps 2 and 3. When a different input attenuator is used, steps 2 and 3 should be repeated. The input sensitivity group associated with each of the four attenuators is listed in Table 2-2.

### Dual Trace Operation

The selection of either Chopped or Alternate mode for dual trace operation will depend on the frequency and har-

TABLE 2-2

VOLTS/DIV Switch Range	Input Attenuation
0.1 mV to 10 mV	× 1
20 mV to .1 V	× 10
.2 V to 1 V	× 100
2 V to 10 V	× 1000

monic relationship of the signals to be displayed. Either mode can be used throughout the bandwidth of the instru-

ment, except that chopped mode is generally selected for lower frequency applications, and alternate mode is generally selected for higher frequency applications. Occasionally, a harmonic relationship will exist between the applied signals and the channel switching frequency of the selected mode. If the interference from the relationship is objectionable, use the other mode of operation.

When the chopped mode of operation is selected, signal information from the two input amplifier channels is alternately sampled at intervals of 2 to 3  $\mu$ s. With proper blanking, during the time interval required for switching between the channels the resultant CRT display will appear as two simultaneous traces made up of alternate sampling segments (see Fig. 2-6). At sweep rates 0.2  $\mu$ s/div and slower the large number of sampling segments of each channel will appear as a continuous trace. At a sweep rate of 0.1  $\mu$ s/div, the segments that make up each trace begin to be noticeable. For applications that require faster sweep rates the alternate segmentation of the traces may be objectionable.

When the alternate mode of operation is selected, signal information from the two input amplifier channels is alternately sampled at the sweep rate of the oscilloscope time-base unit. At sweep rates of 5 ms/div and faster, the display appears as two simultaneous traces. At slower sweep rates, it is apparent that the channels are alternately switched at the end of each sweep.

For a demonstration of dual trace operation, refer to step 5 of First Time Operation at the beginning of this section. Recommended modes of operation for some of the more common applications are listed in Table 2-3.

**TABLE 2-3**

Recommended Switch Settings for Common Dual Trace Applications

Applied Signals	3A3 MODE Switch	3A3 Trigger Switch	Time Base Unit Coupling Switch
Two same or harmonically-related frequencies 250 Hz and above.	ALT	CH 1 or CH 2, whichever carries the lower frequency.	AC
Two same or harmonically-related frequencies, anywhere within full bandwidth.	CHOP	CH 1 or CH 2	AC, DC or AC Fast, as required.
Two dissimilar and non-harmonically-related frequencies, 1 kHz and above.	ALT	COMP	AC Fast only.
Two one-shot signals. Sweep rate limited to 0.1 ms/div maximum.	CHOP	CH 1 or CH 2, whichever has signal of earliest occurrence.	AC, DC or AC Fast, as required.

### Internal Trigger Operation

The signal to be displayed may be used as the internal trigger source for the Time Base Unit. Signals from either channel or the composite signal of both channels may be selected for internal triggering. For a demonstration of internal triggering, refer to step 6 of First Time Operation. Recommended setting of the Type 3A3 TRIGGER switch and the Time Base Unit Trigger Coupling switch for some of the more common dual-trace applications are listed in Table 2-3.

### X-Y Operation

The Type 3A3 can be operated in X-Y configuration with any 2- or 3-series plug-in units<sup>1</sup> except sampling units and certain Time-Base Units which have no provisions for externally applied deflection signals. In applications involving precise phase-angle measurements of signals of the same frequency, a Type 3A3 should be used only with another Type 3A3.

Any two calibrated Type 3A3 Plug-In Units operated in X-Y configuration generally exhibit less than 2° of phase difference between channels of one unit and the channels of the other unit at a frequency of 100 kHz. This phase difference can be cancelled, or adjusted to a known amount, for the .1 mV to 10 mV/DIV deflection factors at frequencies within the limits of the Type 3A3. The following procedure adjusts two Type 3A3 Plug-In Units for precise phase angle measurements. This procedure calibrates or matches two channels (CH 1 and CH 2) of the Type 3A3 and one channel (CH 2) of the reference Type 3A3 to the one channel (CH 1) of the reference unit.

### Amplitude Matching

a. The equipment required for the adjustment steps, b through f, include a Tektronix Standard Amplitude Calibrator (Tektronix Part No. 067-0502-00), a 50 ohm coaxial cable with BNC connectors (Tektronix Part No. 612-0057-00) and a Dual Input Coupler (Tektronix Part No. 067-0525-00) in addition to the two Type 3A3 Plug-In Units and the Type 561A Oscilloscope. Fig. 2-13 shows the above equipment setup for step e.

b. Install the two Type 3A3 Plug-In Units in the vertical and horizontal compartments of the Type 561A Oscilloscope.

c. Connect the output of a Standard Amplitude Calibrator (SAC) to the Channel 1, + input connector of the left-hand Type 3A3 using a 50 ohm coaxial cable.

d. Set the instrument controls as follows:

#### Both Type 3A3 Plug-In Units

MODE	CH 1
TRIGGER	COMP
BANDWIDTH	500 kHz
VOLTS/DIV	10 mV
VARIABLE	CAL

<sup>1</sup>Does not apply to Tektronix Type 565 and RM565 Oscilloscopes which use only vertical plug-in units. However, external horizontal deflection signals can be applied for applications other than precise phase-angle measurements.

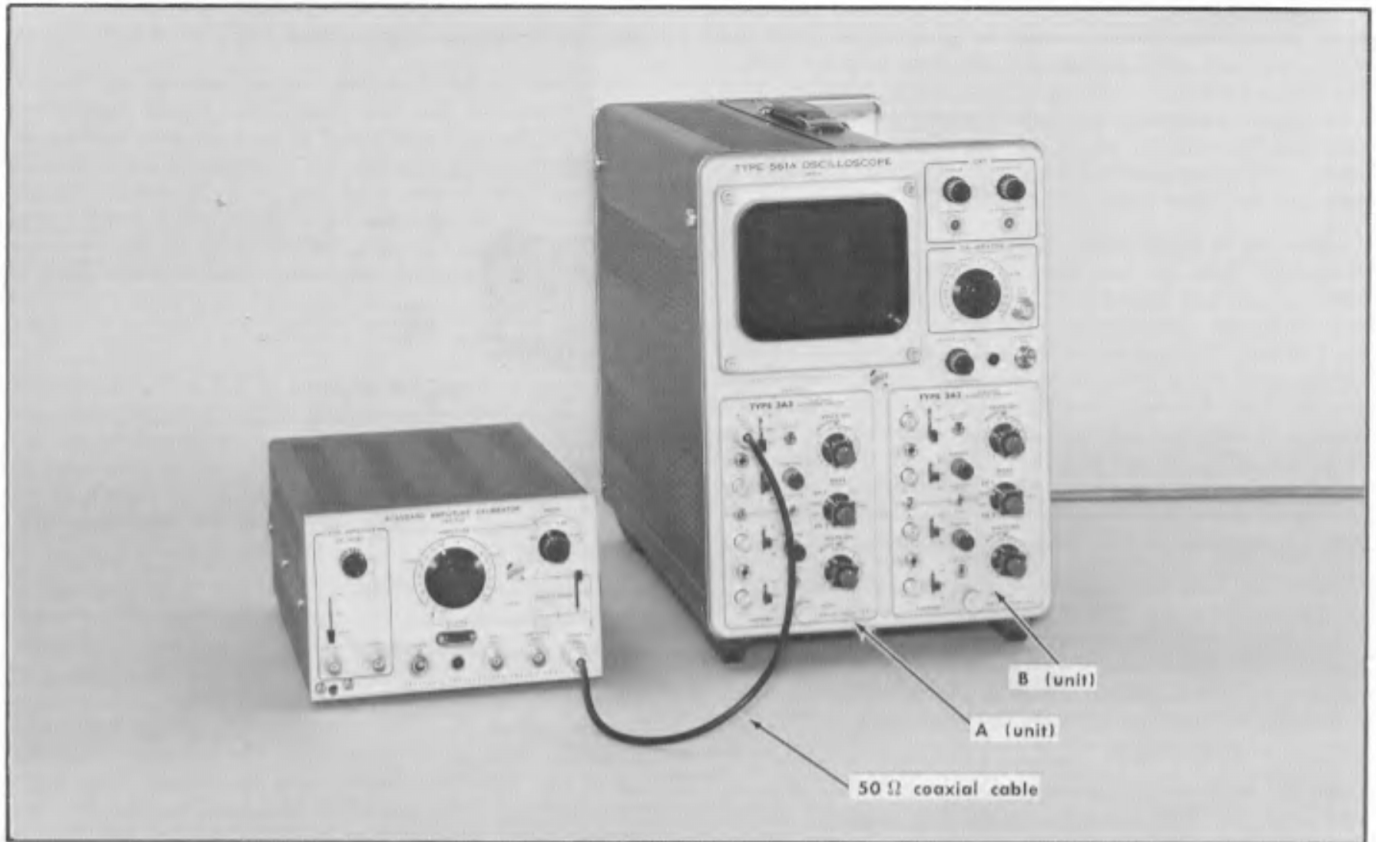


Fig. 2-13. Initial equipment setup for the amplitude adjustment procedure required when the Type 3A3 Plug-In Units are used for precise phase measurements.

POSITION	Centered
+ Input switches	DC
— Input switches	GND

**Standard Amplitude Calibrator**

Amplitude	50 mV
Mode	
Output Selector	upper (unmarked) position

e. Adjust the GAIN of the left-hand Type 3A3 for 5 major divisions of vertical deflection.

f. Move the Standard Amplitude Calibrator signal to CH 1, + input connector of the right-hand Type 3A3 and adjust the GAIN adjustment of the right-hand unit for 5 major divisions of horizontal deflection.

g. Disconnect the Standard Amplitude Calibrator signal.

**Phase Matching**

a. The additional equipment required for the remainder of this procedure includes a sine-wave generator such as General Radio Type 1310A, two 10× attenuators, (Tektronix Part No. 011-0059-00) a 50 Ω termination (Tektronix Part No. 011-0049-00) and a BNC to Banana patch cord (Tektronix Part No. 012-0090-00). Fig. 2-14 shows the equipment

setup. The output of the sine-wave generator is connected to the CH 1, + input connectors of both units using the BNC to banana patch cord, two 10× attenuators and the dual input coupler.

b. Set the Sine-Wave Generator control as follows:

Frequency 100 kHz. (If the application will involve frequencies of 100 kHz and below. If the application will involve a frequency above 100 kHz, use that frequency.)

Level Adjust at each deflection factor setting for a vertical amplitude of 8 divisions.

c. Adjust CH 1 compensation capacitors (using Table 2-4 and Fig. 2-15) of the right-hand Type 3A3 for a lissajous pattern that approaches a straight line. See Figs. 2-16 and 2-17. This adjusts CH 1 of the right-hand unit to CH 1 of the left-hand unit.

d. Move the signal input from CH 1 of the right-hand unit to CH 2. This couples CH 1 of the left-hand unit to CH 2 of the right-hand unit.

e. Adjust CH 2 compensation capacitors (using Table 2-4 and Fig. 2-15) of the right hand unit for a lissajous pattern that approaches a straight line. Leave the left hand unit VOLTS/DIV selector at 100 mV. Add attenuators to the input of the right hand unit as required.

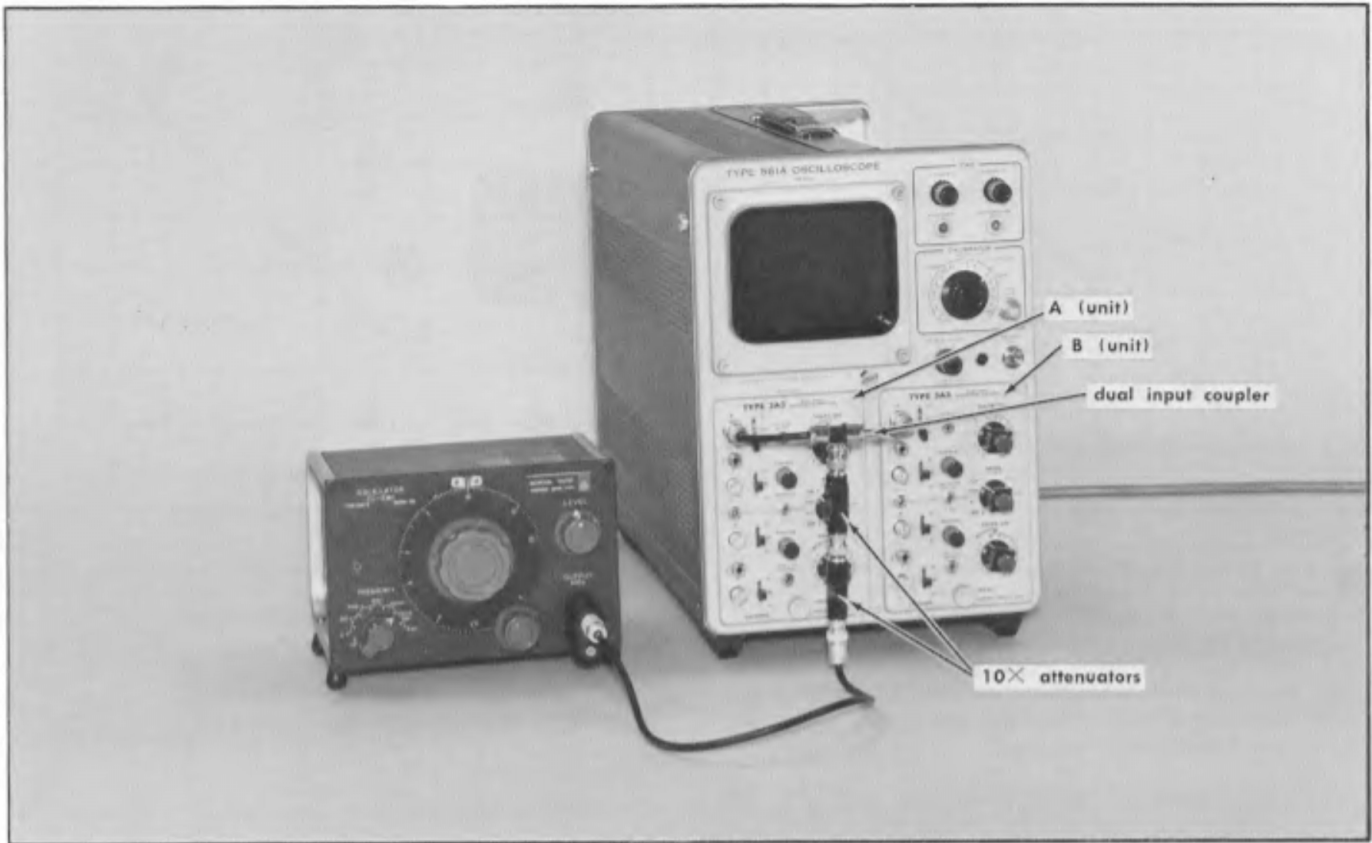


Fig. 2-14. Initial equipment setup for the phase adjustment procedure required when two Type 3A3 Plug-In Units are used for precise phase measurements.

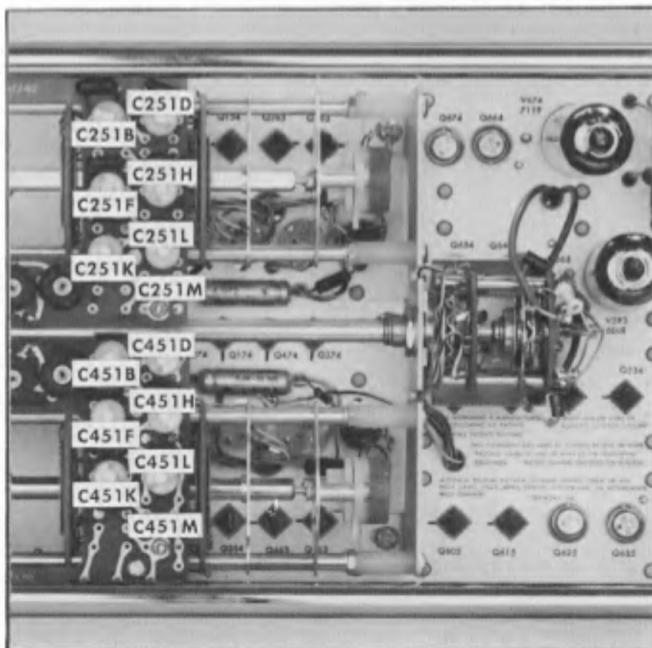


Fig. 2-15. Location of the .1 mVOLTS or 10 mVOLTS/DIV Deflection Factor High Frequency Compensation adjustments.

f. Disconnect the dual input coupler. Interchange the Type 3A3 units between the plug-in compartments of the oscilloscope. Connect the dual input coupler to the CH 2 + Input connectors of both units.

g. Adjust CH 2 compensating capacitors (as listed in Table 2-4) for a straight line.

Each channel of the two units is now adjusted to CH 1 of the reference unit. This phase matching is only valid for these two Type 3A3 units. If the Type 3A3 is operated with a different unit, an inherent phase difference of approximately 2° at 100 kHz should be expected.

TABLE 2-4

VOLTS/DIV (CH 1 or CH 2)	Adjust CH 1 (B Unit)	Adjust CH 2 (A or B Unit)	Attenuators
10 mV	C251M	C451M	0
5 mV	C251L	C451L	0
2 mV	C251K	C451K	0
1 mV	C251H	C451H	10X
0.5 mV	C251F	C451F	10X
0.2 mV	C251D	C451D	10X
0.1 mV	C251B	C451B	100X



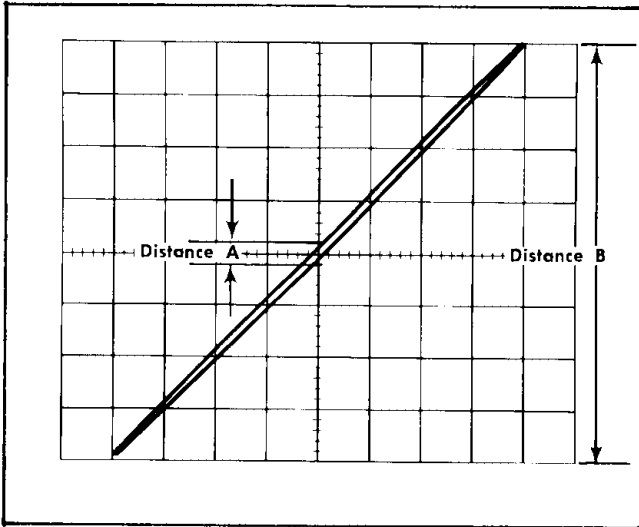


Fig. 2-16. Photograph of the lissajous pattern produced when a common sine-wave is applied to two Type 3A3 Plug-In Units that have approximately 2° of phase difference.

For any frequency comparison application, (lissajous displays) the plug-in unit deflection sensitivities should be checked and adjusted if necessary.

Dual X-Y displays can be obtained using two Type 3A3 Plug-In Units or one Type 3A3 and two channels of a Type 3A74. The left-hand unit should be set for Chopped operation and the right-hand unit for Alternate operation.

### Measuring Phase Difference

Since the display is obtained by applying a common sine wave to the vertical and horizontal deflection inputs of the oscilloscope, the phase difference between the two input channels may be determined by measuring the lissajous pattern and calculating the phase angle as follows: 1) Center the display in relation to the graticule center vertical line. 2) Measure the distances A and B as shown in Fig. 2-16. 3) Distance A is the vertical measurement between the two points where the trace crosses the vertical centerline. 4) Distance B is the measurement of the maximum vertical amplitude of the display. 5) Divide A by B to obtain the sine of the phase angle. Refer to a trigonometric table or slide rule for the phase angle ( $\phi$ ). Example. The applied common sine-wave produces an elliptical lissajous pattern with

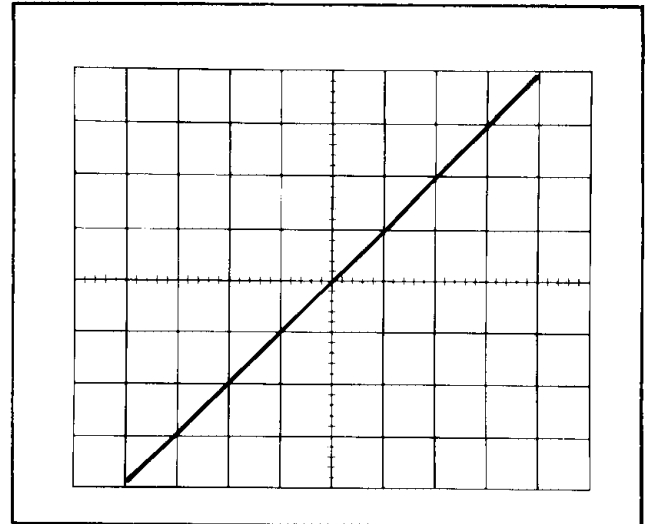


Fig. 2-17. Photograph of a lissajous pattern produced when a common sine-wave is applied to two Type 3A3 Plug-In Units that have approximately zero degrees of phase difference.

distance A = 1 minor division and distance B = 8 major divisions or 40 minor divisions.

Using the formula:  $\text{sine } \phi = \frac{A}{B}$

Substituting the given dimensions:  $\text{sine } \phi = \frac{1}{40} = 0.025$

From a trigonometric table or slide rule: Phase  $\phi = 1.5^\circ$

From the above it can be shown that if distance A is adjusted to zero (see Fig. 2-17) the lissajous pattern appears as a straight line and the phase angle difference between the two channels will be zero.

### Supplemental Applications

Two conventional cathode followers are used to couple the signals selected by the TRIGGER switch to pins 11 and 12 of the Type 3A3 interconnecting plug. Jacks may be installed in the rear panel of the oscilloscope for access to these signals (BNC jacks recommended: Type UG109A/U, Tektronix Part No. 131-0126-00). With the jacks installed, the ground referenced signals may be used either single-ended or differentially for applications which include driving slave oscilloscopes and X-Y plotters.

# SECTION 3

## CIRCUIT DESCRIPTION

Change information, if any, affecting this section will be found at the rear of the manual.

### Introduction

This section of the manual presents a description of the Type 3A3 circuitry, keyed to the block diagram and circuit schematics in Section 9. Detailed circuit analysis include some simplified drawings of the circuits to enable the reader to readily follow signal or current paths as the description is read. Changes or corrections to this section may be found at the rear of the manual.

### General Description and Functional Block Diagram

A functional block diagram of the Type 3A3 is located in Section 9 of the manual, and in Fig. 3-1. The unit contains two independent differential amplifier channels, with each channel providing either differential or single-ended input signal application. Either channel may be selected to produce the display, or the two channels may be electronically switched to produce a dual trace display.

A trigger output circuit provides three selections of trigger signal (CH 1, CH 2, or the composite of both channels) to the plug-in connector as an internal trigger source to the companion Time-Base Plug-in Unit.

Signals applied to any input connector of the Type 3A3 are either AC or DC coupled via the input selector switch to the input attenuator. A GND position on the input selector grounds the attenuator input and connects the coupling capacitor through a resistor to the BNC input (+ or -) connector. Therefore, the coupling capacitor is charged to the DC level of an applied signal. Thus, there is no surge current from the capacitor charge when the input selector is switched from the GND position to the AC position, and only the AC component is coupled to the amplifier input.

Attenuation for both sides of each channel is provided by RC type attenuators with attenuation steps of 1X, 10X, 100X, and 1000X.

The output of the attenuator connects to the input amplifier, which contains a constant-current supply plus balanced input and output circuits that provide a high common-mode rejection ratio (CMRR).

The differential output from the input stage is then DC coupled to a gain-switching amplifier. This amplifier provides seven gain selections and when operated in conjunction with the four input attenuator steps, provides the .1 mV/div to 10 V/div deflection factors in a 1, 2, 5 sequence. The 500 kHz or 5 kHz bandwidth of the unit is also selected in this stage.

The differential output signal from the gain switching amplifier drives the trigger amplifier, plus an emitter-coupled

differential amplifier. Vertical POSITION adjustment and a VARIABLE gain control are provided in this amplifier. A range of at least 2.5:1 variation in gain by this control provides continuous adjustment through each step of the VOLTS/DIV selector and increases the 10 VOLTS/DIV position to at least 25 V/div uncalibrated.

The output signal from the channel gain balancing amplifiers is then DC coupled through a switching circuit to the output amplifier for both channels. This switching circuit provides the four modes of operation. When the MODE selector is switched to either CH 1 or CH 2 position the driver multivibrator is disabled and the switching circuit connects the signal from the selected channel amplifier to the input of the composite output amplifier. Setting the MODE switch to the CHOP position causes the driver multivibrator to free run at an approximate 400 kHz rate. This output drives the switching circuit so that it chops between Channels 1 and 2 and the unit presents a display of both channels. When the MODE switch is in the ALT position, the driver multivibrator becomes a monostable multivibrator and requires an input pulse to cycle. This pulse is generated at the end of each horizontal sweep by the companion time-base plug-in unit. Therefore, the switching circuit alternates between channels to display both at a rate determined by the position of the Time/Div selector.

In the sequence with the drive signals to the mode switching circuit, the driver multivibrator provides both a chop blanking pulse to the plug-in oscilloscope CRT circuit, and a synchronizing pulse to the companion time-base plug-in unit.

The chop blanking pulses are applied via pin 24 of the interconnecting plug (J21) to the CRT cathode, when the CRT Cathode Selector switch on the back panel of the oscilloscope is in the Chopped Blanking position. This pulse blanks the CRT beam during switching time to eliminate the undesirable vertical transit lines between the dual display.

The dual X-Y sync pulse output is applied via pin 4 of the left hand interconnecting plug, to pin 3 of the right hand interconnecting plug. This provides dual X-Y display capability using the Type 3A3 and a companion vertical plug-in.

Differential signal voltages from the selected channel amplifiers are converted to push-pull signal currents by the output amplifier. This output drives the high impedance of the vertical deflection plates for the CRT. A GAIN adjustment in the emitter of the push pull amplifier provides a gain calibration adjustment for the unit.

The output signal from the amplifier is also connected through the TRIGGER selector, when it is switched to the COMP position, to the trigger output amplifier. This provides a composite trigger signal from either or both channels to internally trigger the time base unit.

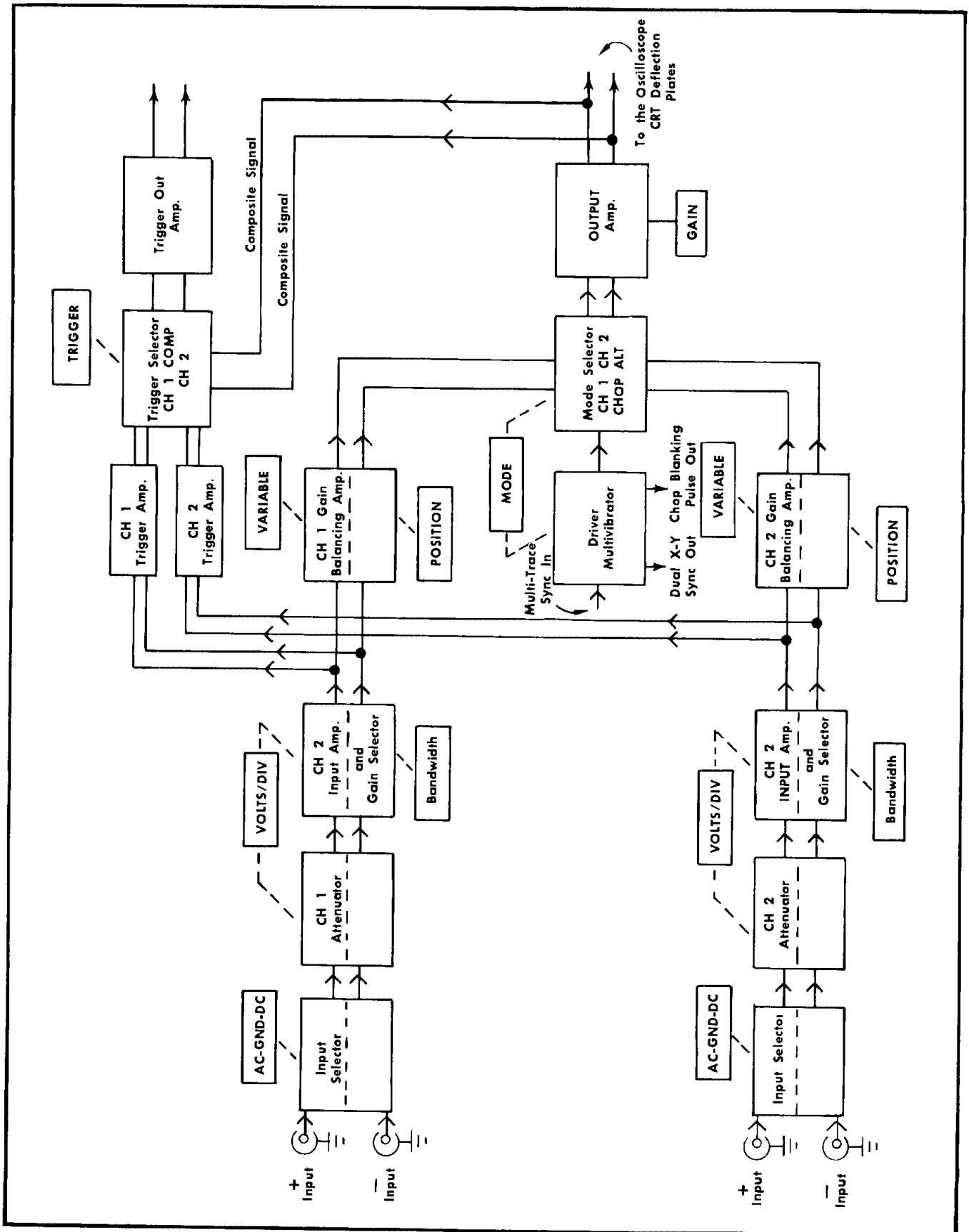


Fig. 3-1. Functional block diagram of the Type 3A3.

The trigger output amplifier is a cathode follower amplifier which provides a high current low impedance output signal with a DC reference adjustable to zero volts. This provides the trigger to the companion time base unit. It also provides a low impedance signal source to drive auxiliary equipment if provisions such as jacks, are installed in the oscilloscope main-frame and connected to pins 11 and 12 of the interconnecting plug.

## DETAILED CIRCUIT DESCRIPTION

The illustrations in this section are provided as an aid in understanding the circuit descriptions. For electrical values and the complete circuit, refer to the schematics in section 9.

The input coupling, attenuator and channel amplifier circuits are identical except for circuit and component numbers. Therefore, the circuit description of Channel 1 is applicable to Channel 2. The + side of Channel 1 is described.

### Input Coupling

A three-position selector SW101 and associated circuitry (Fig. 3-2) provide the following functions:

In the DC position, signals applied to the input connector are directly coupled through the input attenuator to the gate of the input amplifier transistor Q114.

In the GND position, the input to the amplifier is grounded through the attenuator and the switch. Signals applied to the + input connector charge the coupling capacitor C101 through R101 to the DC or average level of the applied signal. By precharging the coupling capacitor C101, no gate current flows when the Input selector is switched to the AC position and the trace remains on screen.

In the AC position, frequencies below 1.6 Hz are attenuated.

When the input selector is placed in either the AC or DC position and the VOLTS/DIV switch is in the  $1\times$  (.1 mV to 10 mV) attenuator position, input R and C for CH 1 is established by R113 (1 M $\Omega$ ) and the stray circuit capacitance in shunt with C109. Input time constant for the  $1\times$  attenuator range is normalized at 47  $\mu$ s by adjusting C109. The variable capacitors C105A, C106A or C107A are adjusted so all attenuator ranges maintain a standard input time constant through each position of the VOLTS/DIV selector.

### Input Attenuator

An attenuation factor of  $1\times$ ,  $10\times$ ,  $100\times$  or  $1000\times$  is selected simultaneously for both the + and - Inputs with the VOLTS/DIV selector. These attenuators have the following characteristics:

1. The input R and C are normalized for all settings of the VOLTS/DIV switch for both input connectors. Adjustable capacitors C109-C209 ( $1\times$ ), C105A-C205A ( $10\times$ ), C106A-

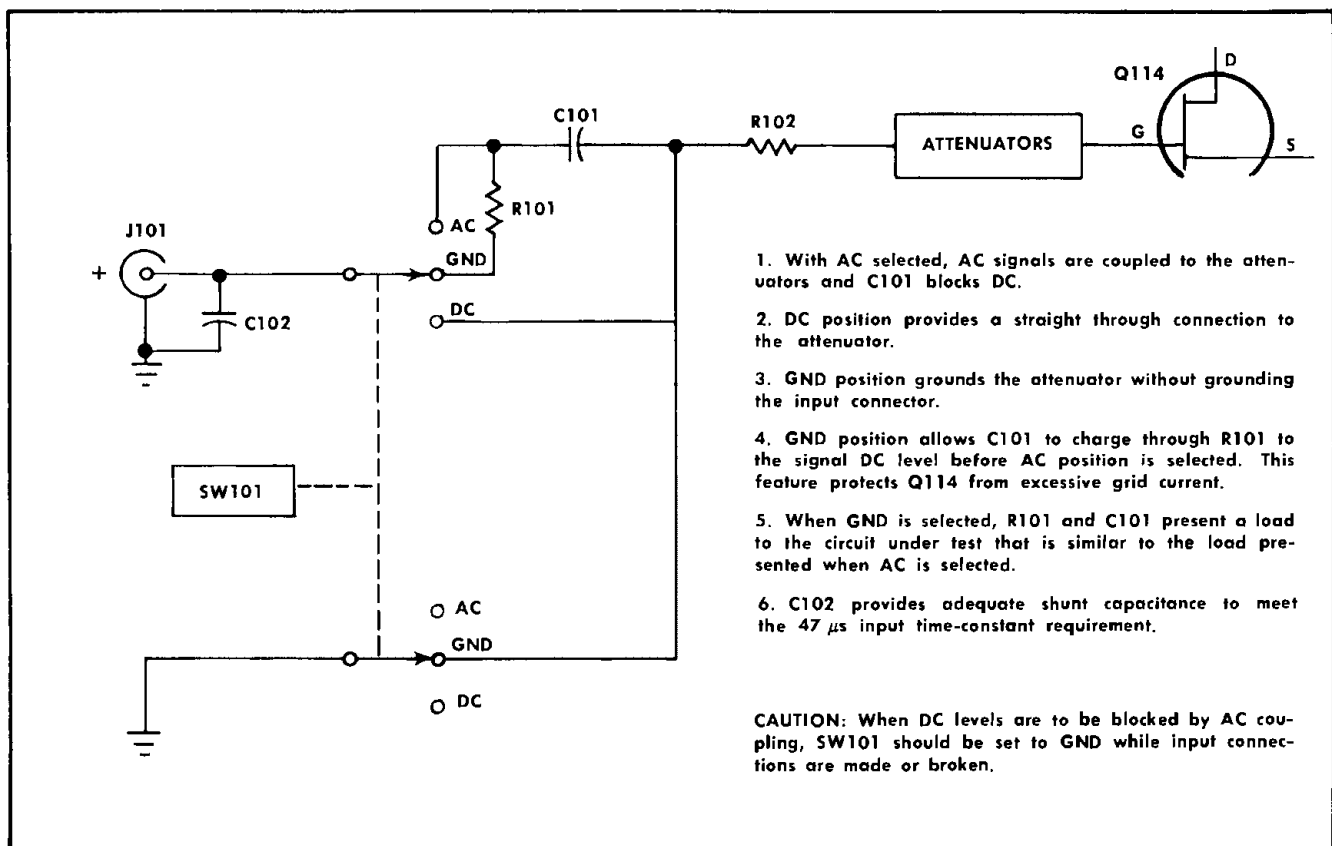


Fig. 3-2. Partial diagram showing the Input Coupling circuit with SW101 set to GND.

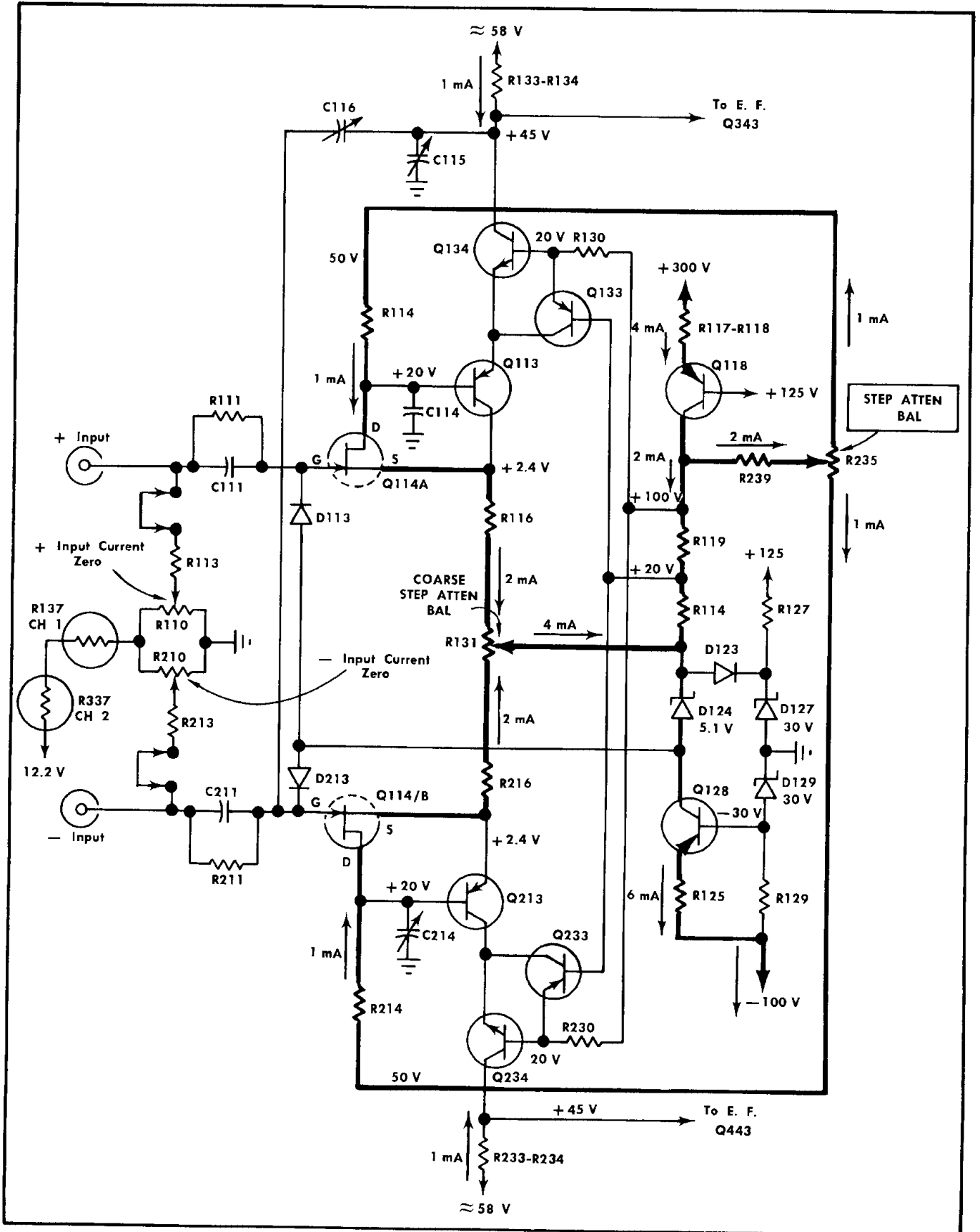


Fig. 3-3. Simplified (partial) diagram of the input amplifier with approximate current and voltage values. Heavy lines indicate bootstrap circuit. Voltage values are with input grounded.

C206A (100 $\times$ ) and C107A-C207A (1000 $\times$ ) provide this normalization adjustment.

2. The resistance (DC or low frequency) attenuation ratios of the attenuator are equalized by adjusting R105F, R106F, and R107F in each attenuator network for the + input. With these adjustments accurately set, optimum common mode rejection through the attenuators is achieved.

3. The reactance (AC or high frequency) attenuation ratio of the attenuator is calibrated by adjusting C105C-C205C, C106C-C206C and C107C-C207C.

4. High frequency compensation for the gain switching amplifier stage is provided by adjustments C251B, C251D, C251F, C251H, C251K, C251L, and C251M.

A maximum common mode signal range of  $\pm 20$  volts (40 volts peak to peak, AC) is provided over the 1 $\times$  range of the attenuator (.1 mV to 10 mV range of the VOLTS/DIV switch). This increases to  $\pm 200$  volts (400 volts peak to peak, AC) for the 10 $\times$  range (20 mV to .1 V range of the VOLTS/DIV switch) and  $\pm 350$  volts (700 volts peak to peak, AC) for the remaining 100 $\times$  and 1000 $\times$  ranges of the attenuator (.2 V to 10 V range of the VOLTS/DIV switch). Common mode signal amplitudes up to  $\pm 20$  volts peak to peak, AC at the gate input will produce essentially no change in the division of the common source current between the FET's. Signals in excess of this cause deterioration of the common-mode rejection ratio.

## Input Amplifier

The input amplifier is basically a cascode paraphase or cascode differential amplifier, depending on the signal application, with a constant current source. Circuit differences between the + and - sides of the amplifier are minimized by incorporating the following features in the input amplifier circuit:

1. Constant current sources (Q118, Q128) for the amplifier. They establish the amplifier's operating current and greatly reduce differential signal currents that might otherwise appear in the amplifier when subjected to common mode voltage signals.

2. A  $g_m$  multiplier stage around the FET Q114, to offset gain variation due to temperature changes (about 0.35%/°C) and stabilize the forward transconductance ( $g_{fs}$ ) of the FET.

3. Close tolerance (within 1/4%) load resistors set the drain current through each section of Q114, such that the current through each half of the input amplifier is closely balanced.

4. A collector impedance multiplier Q133-Q233, reduces the common mode error current developed by the  $h_{oe}$  of the transistors Q134-Q234.

A simplified diagram of Channel 1 Input amplifier is shown in Fig. 3-3. A constant source of floating power supply, consisting of Q118, Q128 and the associated circuitry, provide a constant current of approximately 2 mA for each half of the input amplifier. The voltage developed across R124 sets the voltage across each section of the dual FET Q114, and R119 sets the constant 2 mA current through the input amplifier. The 1/4% tolerance of the drain load resistors R114 and R214 plus the Step Atten Balance potentiometer

R235, balance the current distribution through each half of the amplifier. The additional 2 mA is external current which flows from the external + 125 V power supply, through the cascode amplifier Q113-Q213 and Q134-Q234 to the floating power supply.

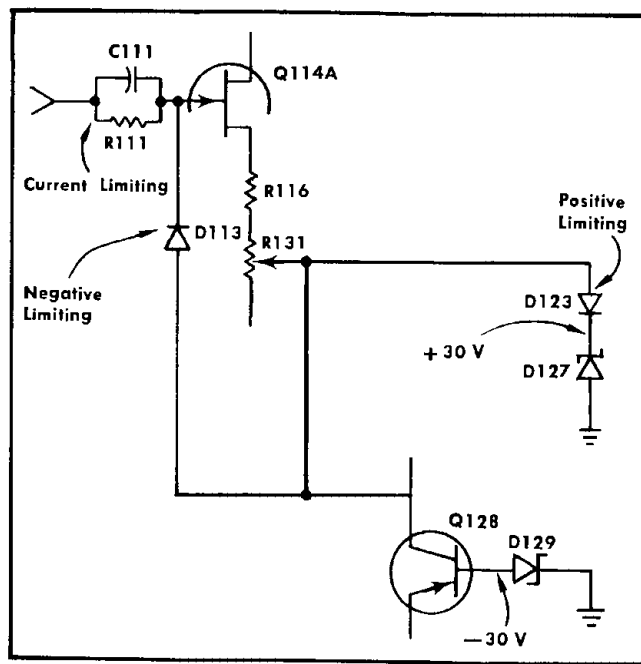


Fig. 3-4. Simplified diagram of input circuit, to illustrate, input signal limiting.

Changes in common mode signal level at the amplifier input are reflected through the gate-to-source junction of Q114 to the common source point of the FET. (The center point of R131). Since the current is constant through R124 and R119, a unit of voltage at the input is bootstrapped through the floating power supply to the base-emitter junctions of the transistors (Q133, Q134, Q233, Q234) and through R239 plus R235, to the drain-source voltage for Q114. The operating voltages and currents of the transistors and the FET are therefore held constant and the circuit remains balanced through variations of common mode input signal level within the maximum input limits of the amplifier. An approximate 6 mA source current through Q128 in the floating power supply is distributed as shown in Fig. 3-3.

Another determining factor in the CMRR of the input amplifier is the collector current stability of Q134-Q234. A small error current is generated through the collector to base impedance of Q134-Q234 when the common mode input signal shifts. This error is returned via Q133-Q233 to the emitters of Q134-Q234. Therefore, the effective collector to base impedance of Q134-Q234 is multiplied or increased by the beta of transistor Q133-Q233 to minimize the error current effect and increase the amplifier CMRR.

Signal current flow and circuit operation for the input stage is as follows: Signal applied to the + input is amplified by Q114A and applied to the base of Q113. This produces a signal current through the cascode paraphase

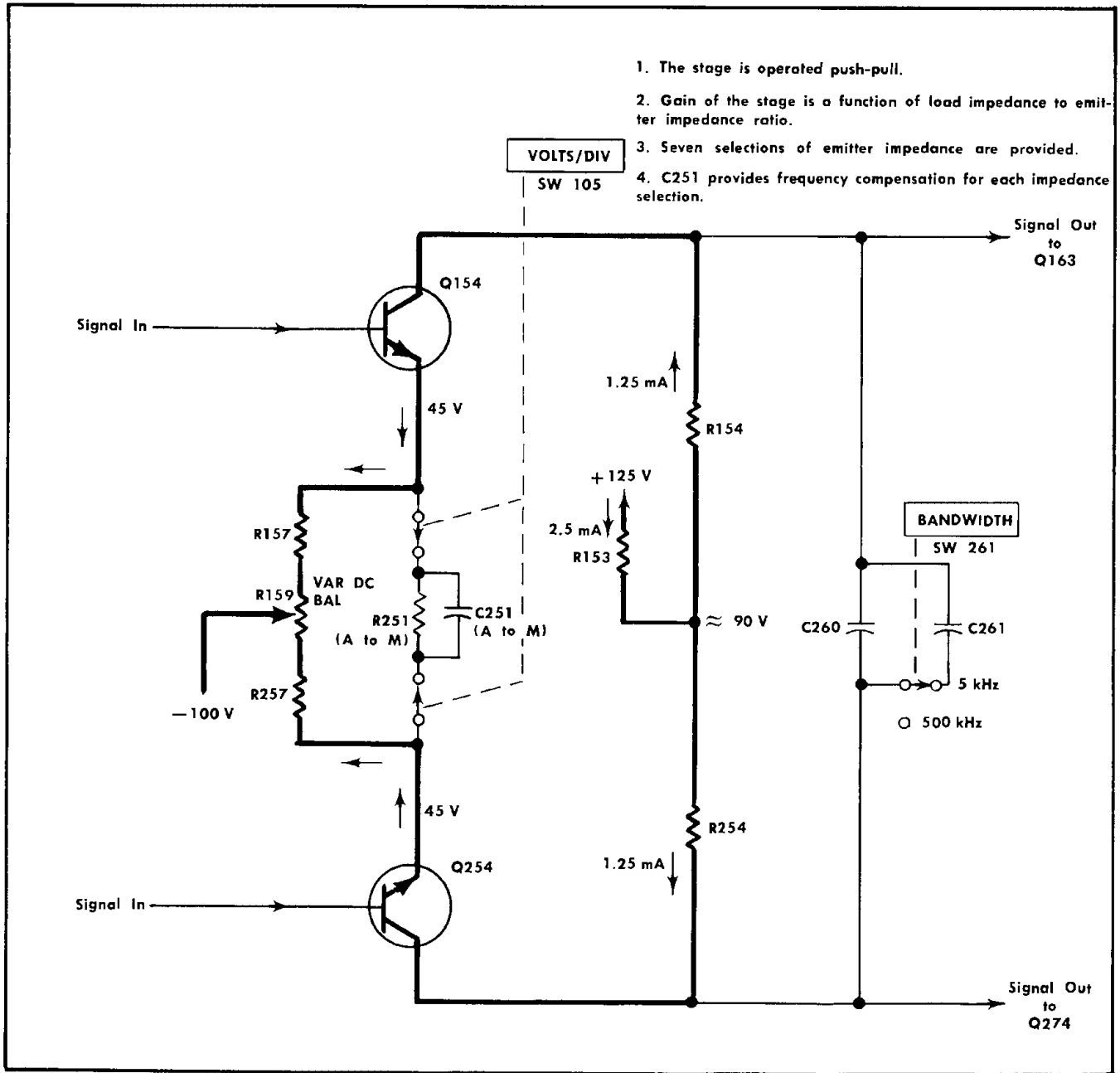


Fig. 3-5. Partial diagram of the gain switching stage. Heavy lines indicate path for constant current. (Currents and voltage figures are approximate with the inputs grounded.)

amplifier that develops an output signal voltage across the collector load impedance (about 12.9 kΩ) for Q134 and Q234. This signal is then applied as a push-pull signal to the emitter followers Q143 and Q243.

Gain of the input amplifier is a function of the ratio of the collector load impedance for Q134-Q234 to the total resistance R116, R216 and R131 or approximately

$$\frac{2 (12.9 \text{ k}\Omega)}{R116 + R216 + R131}$$

Transistors Q113 and Q213 serve as transconductance ( $g_m$ ) multipliers for the FET Q114A and Q114B. Q113 sam-

ples a small portion of Q114A drain current ( $I_d$ ) and applies approximately beta times this sampled amount back to the source terminal of Q114A. Therefore, changes in  $I_d$  become independent of the dynamic characteristics of the field effect transistor, and effects of temperature variations on the FET transconductance are minimized by a factor that approaches the beta of Q113.

Gate leakage current ( $I_{gss}$ ) for the input amplifier is temperature dependent; therefore, a temperature tracking compensation circuit is used to balance and offset the effects of this leakage current. The series connected thermistors R137 and R337 are part of a voltage divider circuit from



ground through R110-R210, to the -12.2 V supply. A voltage is set by the input current zero adjustments R110 and R120 that is equal but opposite in polarity to the voltage developed at the amplifier input by the  $I_{qss}$  through the input resistors R113 and R213. The voltage at the input to the amplifier remains at 0 V with respect to ground. For example: A gate-to-source leakage current of approximately 100 pA will develop about  $\pm 0.1$  mV at the input. Adjusting R110 for -0.1 mV will shift the input or gate of Q114A to 0 V with respect to ground and the effect of  $I_{qss}$  is eliminated. The thermistors are mounted on each side of the input amplifier board. The temperature compensation

is therefore an average of the temperature change for each side of the input amplifier circuit board.

The wire link in series with the gate return to ground can be removed if desired. This provides a floating input or a substantially higher input resistance. The signal source must provide the DC return path for the input leakage current and only DC coupled signals within the range of the .1 mV/DIV to 10 mV/DIV deflection factors can be accurately measured with the floating input.

Circuit protection from input voltages that may exceed  $\pm 30$  V is provided by the following:

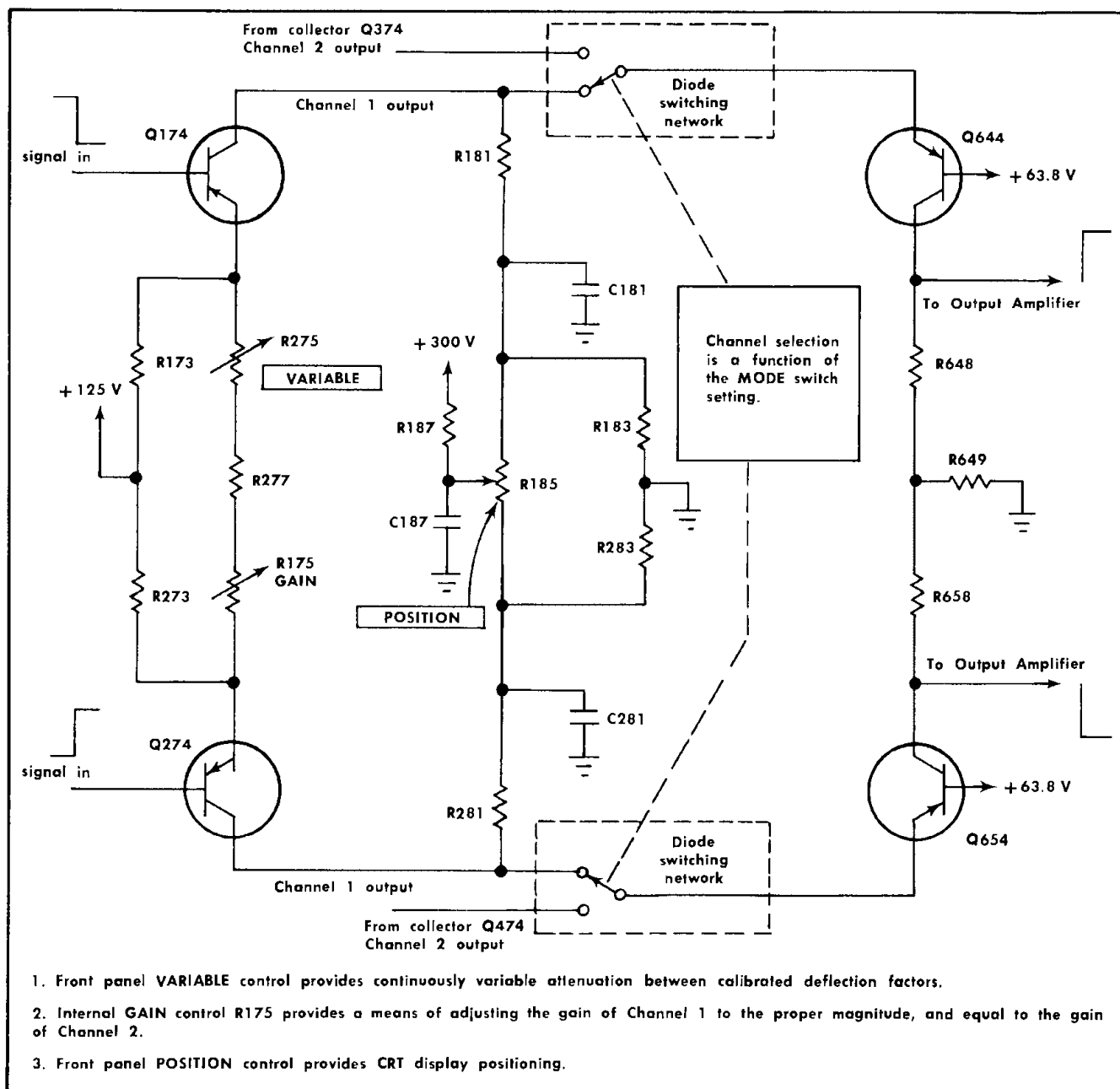


Fig. 3-6. Partial diagram showing the output of channel 1 selected by the electronic switching circuit. The combined circuit is two conventional cascode amplifiers operated as a conventional emitter coupled push-pull amplifier.

### Circuit Description—Type 3A3

1. Negative signals whose amplitudes are greater than  $-30\text{ V}$  are limited through D113, the collector-to-base junction of Q128 and D129 to ground. See Fig. 3-4.

2. Positive signals, above  $+30\text{ V}$  are limited through the gate-to-source junction of Q114A, R116, R131, D123 and D127 to ground.

3. The series elements composed of R111-C111 limit the input current to protect the gate-to-source or diode junctions when the limiting action is occurring.

C116 and C216 provide a cross neutralization adjustment to compensate for the capacitance between the input leads to the amplifier.

C115 provides a differential adjustment to equalize the collector load time constants of the output transistors, Q134 and Q234. It is adjusted for maximum CMRR at the high input signal frequency range.

C214 provides a differential equalizing adjustment for the dynamic output impedance of the FET, Q114.

### Gain Switching Stage

Signal outputs at the collectors of Q134-Q234 are DC coupled through an emitter follower Q143-Q243.

Gain of the stage is determined by the ratio of the total collector load impedances (essentially R154-R254) to the ef-

fective common emitter impedance (essentially R251). Seven values of emitter impedances are selected with the VOLTS/DIV switch, to provide the selectable gain feature. These impedance components (R251A, R251C, R251E, R251G, R251J, R251L, and R251M, with their associated capacitors) parallel the current balancing circuit R157, R159 and R257. Inspection of the collector load and effective emitter resistance values show ratios ranging from about 25:1 to 0.25:1 at the lower sensitivity settings of the VOLTS/DIV switch. (To check these ratios refer to the Attenuator schematic in section 9 for the selectable component values).

The Var DC Bal R159 adjusts the current through R157 and R257 for 0 V, between the emitters of Q174 and Q274, so there will be no current through the VARIABLE control or Gain adjustments.

The bandwidth of the amplifier is limited to approximately 500 kHz and 5 kHz by the bandwidth selector SW261, which adds or removes an additional capacitor C261 across the collector load of the gain switching amplifiers Q154-Q254. The 5 kHz position of the BANDWIDTH selector attenuates high frequency noise, so low frequency measurements may be more easily performed.

### Gain Balancing and Output Driver Stage

The push-pull signal from the gain switching stage is applied through emitter followers Q163-Q263 to the gain balancing stage or driver amplifiers Q174-Q274, plus the trig-

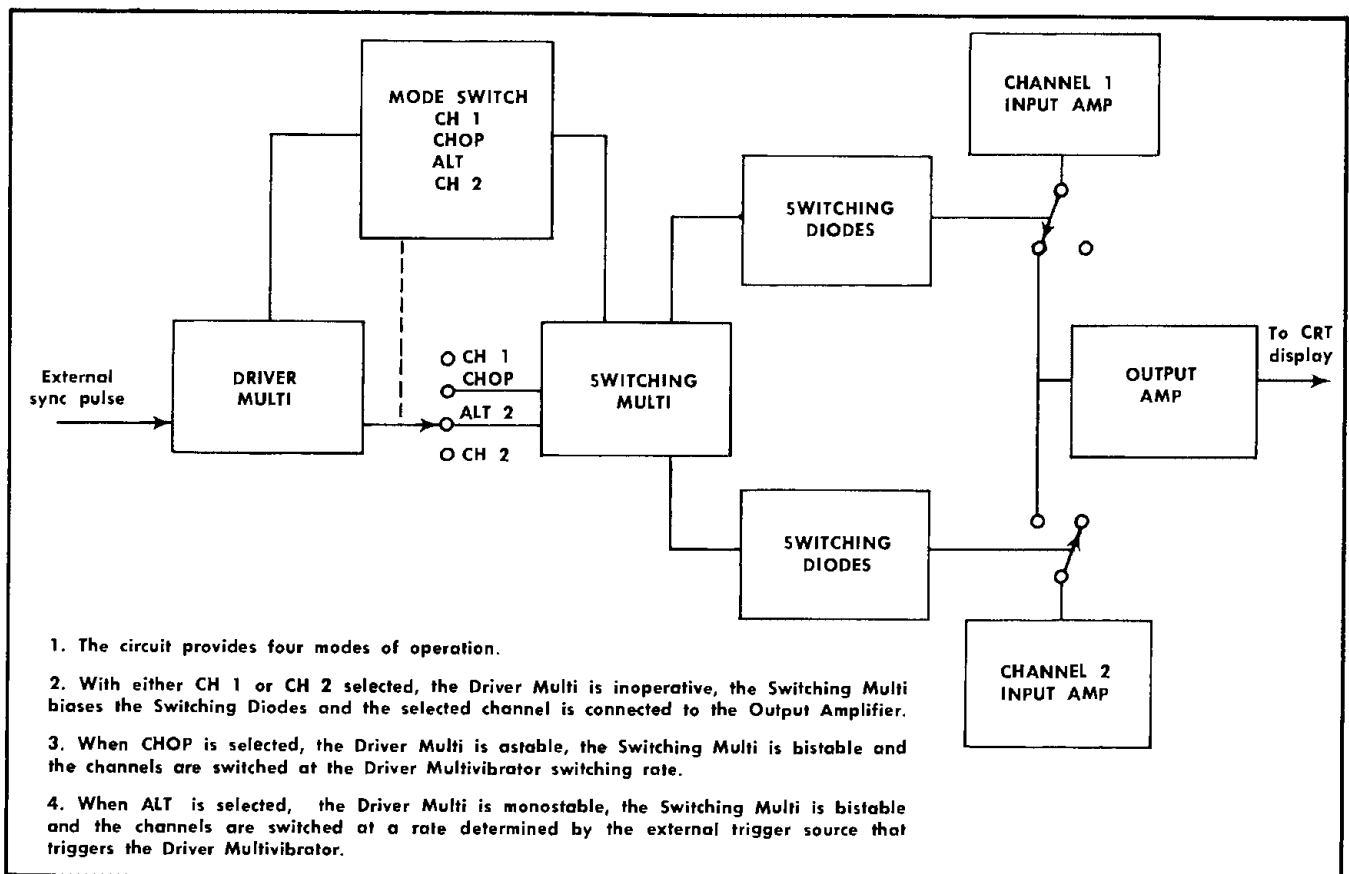


Fig. 3-7. Block diagram of the Electronic Switching circuit.

ger amplifiers Q504-Q514. The emitter followers provide the isolation between the gain switching stage and the variable gain adjusting stage. They also provide the signal drive to the trigger amplifier stage Q504-Q514.

Q174 and Q274 with associated circuitry provide CRT display vertical positioning, gain adjustment to calibrate the VOLTS/DIV selector positions, continuously variable attenuation between calibrated deflection factors and gain balancing between Channel 1 and Channel 2.

The MODE switch SW602 electronically selects either the output of this stage or its counterpart from Channel 2, to current-drive the emitters of Q644 and Q654. With either channel selected, the combined circuitry is two cascode amplifiers connected and operated as conventional emitter coupled push-pull amplifiers (see Fig. 3-6).

The emitters of Q174 and Q274 are returned to +125 volts through R173 and R273 establishing a DC operating current of about 3 mA for each side. (An emitter voltage of about +75 volts is set by preceding circuitry.)

The voltage divider network (between Q174-Q274 collectors) provide CRT display positioning. This is accomplished by diverting current from one side of the circuit to the other with the front panel POSITION control R185.

Since the combined circuit is two cascode amplifiers connected and operated as a conventional push-pull amplifier, the voltage gain of the circuit can be derived as a function of the ratio of output impedance to input impedance. In this circuit, the output impedance is the Q644-Q654 collector impedance, and the input impedance is the Q174-Q274 emitter impedance. Since VARIABLE control R274 and Int Gain R175 set the effective emitter impedance, they control the gain of the combined circuit.

VARIABLE control R275 is a front-panel control. It provides continuously variable attenuation between the calibrated deflection factors and extends the attenuation range to at least 25 volts per division.

Int Gain R175 provides a means of balancing the gain of Channel 1 with the gain of Channel 2 at the proper magnitude.

### Electronic Switching Circuit

The electronic switching circuit provides four operating modes that are selected by the MODE switch SW620. The circuit contains a switching multivibrator, a driver multivibrator and switching diodes for each channel. See Fig. 3-7.

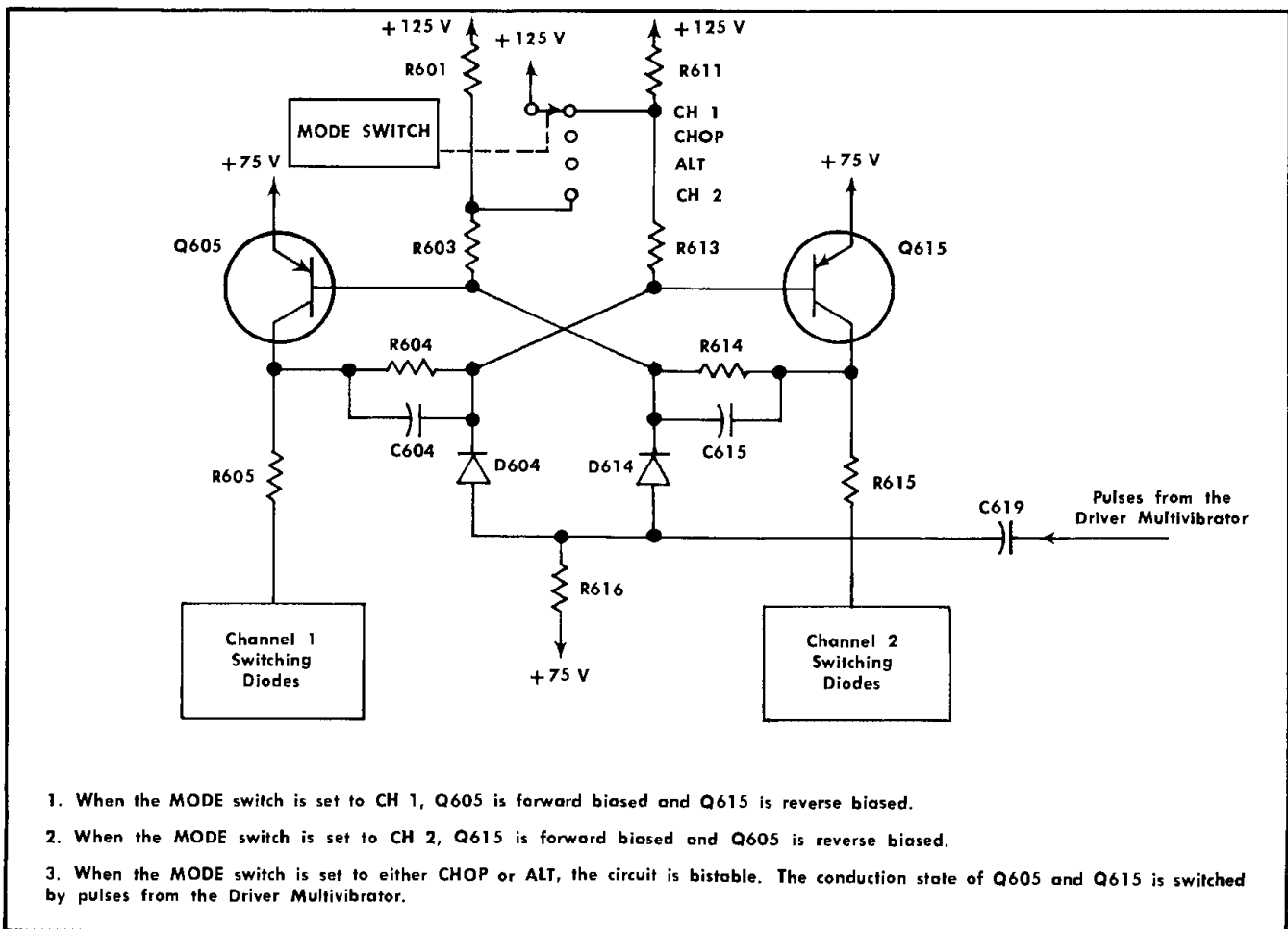


Fig. 3-8. Partial diagram showing the Switching Multivibrator circuit.

### Circuit Description—Type 3A3

When the MODE selector is positioned to either CH 1 or CH 2, the driver multivibrator is inoperative. The switching multivibrator is held in a state with either of the two sides turned on. The on side of the switching multivibrator opens the circuit through the switching diodes and connects the selected CH 1 or CH 2 amplifier to the output amplifier through Q644 and Q654.

When the MODE switch is set to either CHOP or ALT positions, the driver multivibrator is activated, the switching multivibrator becomes bistable and electronically turns the switching diodes on and off. The CH 1 and CH 2 amplifiers are thus alternately connected to the output amplifier. This switching between the two channels produces the dual display.

Q605 and Q615 with their associated circuitry form the switching multivibrator. The circuit determines which channel is coupled to the output amplifier by controlling the bias of the switching diodes.

With the MODE switch set to CH 1, the junction of R611 and R613 is returned to +125 volts (see Fig. 3-8). This applies sufficient reverse bias to Q615 to hold it in cutoff. Q605 is forward biased. Its conduction biases the switching diodes so the signals from the channel 1 amplifier are coupled to the output amplifier.

With the MODE switch set to CH 2, the junction of R601 and R603 is returned to +125 volts. Q605 is cut off and Q615 conducts. This biases the switching diodes so the sig-

nals of channel 2 are coupled to the output amplifier and channel 1 is decoupled or disconnected.

When the MODE switch is set to either CHOP or ALT positions, the switching multivibrator is a bistable circuit. The conduction state of Q605 and Q615 are switched by pulses from the driver multivibrator. The positive portions of the pulses are steered to the base of the conducting transistor by diodes D604 and D614.

Two sets of silicon diodes form the switching diode circuits that couple and decouple the input amplifier channels with the output amplifier. The conduction state of the switching multivibrator transistors controls the bias of the switching diodes and determines which channel is coupled or decoupled to the output amplifier.

When Q605 conducts (see Fig. 3-9), D646 is turned on and a voltage of about +65.6 volts is established at its anode. This voltage reverse biases D642, D643, and D645. With these diodes reverse biased, R642 and R643 are decoupled from the Q174-Q274 collector circuits and D641-D644 are forward biased. With D641 and D644 forward biased, the collectors of Q174 and Q274 are coupled to the emitters of Q644 and Q654. Signals from channel 1 are now applied to the output amplifier.

When Q605 is in cutoff (see Fig. 3-10), D645 is forward biased and a voltage of about +63.2 volts is established at its cathode. This voltage will forward bias D642 and D643, which connects R642 and R643 to the Q174-Q274

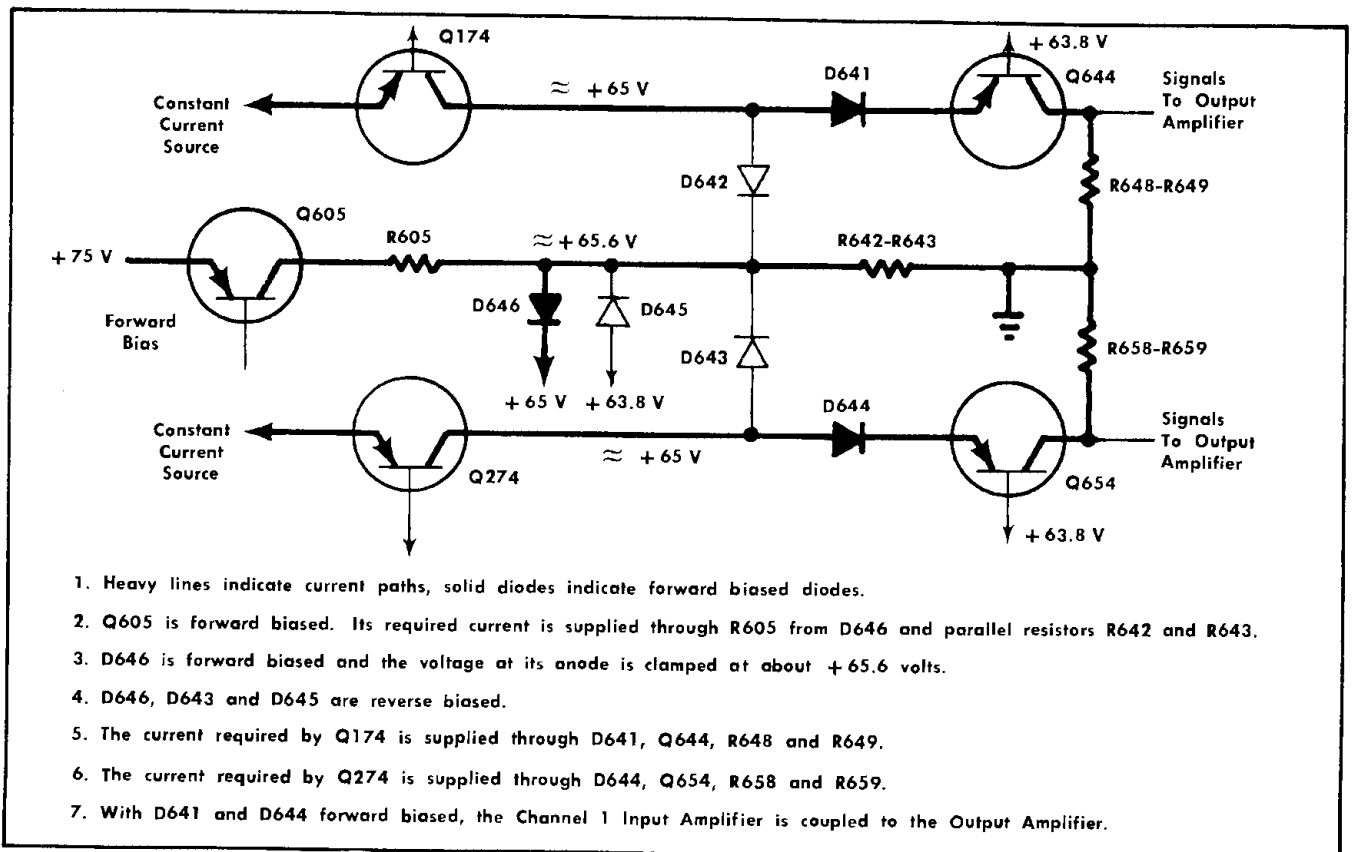


Fig. 3-9. Partial diagram showing the channel 1 set of Switching Diodes when Q605 is forward biased.

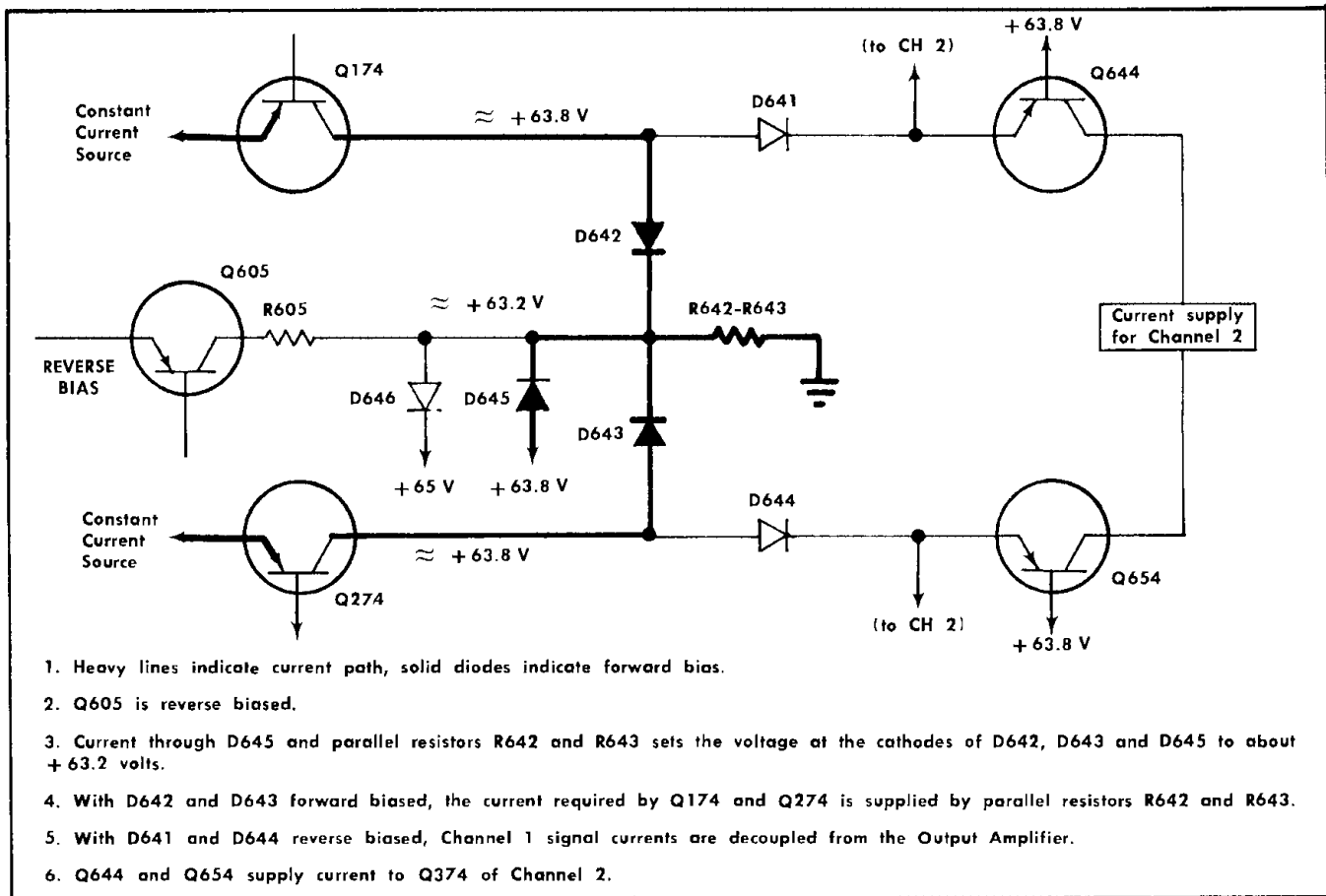


Fig. 3-10. Partial diagram showing the Channel 1 set of Switching Diodes when Q605 is reverse biased.

collector circuits. D641, D644 and D646 are reverse biased and disconnect the collector output of Q174-Q274 to the output amplifier.

The conduction state of Q615 controls the bias of the diodes in the channel 2 diode set in the same manner as Q605 controls their counterparts in the channel 1 set.

R642 and R643 provide the collector load and current return path for Q174 and Q274 when channel 1 is decoupled from the output amplifier. R652 and R653 provide the same function for Q374 and Q474 when channel 2 is decoupled.

Since the coupling and decoupling action of the diodes is dependent on the voltage developed across a conducting silicon diode, the voltage difference between the voltage supplies for this circuit is critical (see Switching and Output Amplifier schematic). A voltage divider circuit consisting of Q684, Zener diode D687, the two silicon diodes D688 and D689 and their associated circuitry, insure that the correct difference voltage is maintained between the supply voltages.

The driver multivibrator consists of Q625-Q635 and the associated circuitry (Fig. 3-11). When operating, the circuit provides three output pulses. A positive pulse to the switching multivibrator, a positive pulse to synchronize the companion plug-in unit, and a chop blanking pulse for the CRT circuit to blank the beam during channel switching

time when operating in the CHOP mode. The multivibrator frequency can be synchronized to an external sync pulse, from the companion plug-in unit through pin 3 of the interconnecting plug P11.

With the Mode switch in CH 1 or CH 2 positions, the base of Q625 is returned through the switch contacts to the junction of R635 and the cathode side of diodes D625-D635. This sets the potential on the base of Q625 to approximately -51 volts, which is sufficient to reverse-bias the base emitter junction so the multivibrator is inoperative.

When the MODE switch is placed in the CHOP position, the base of Q625 is connected through the switch to the junction of R633-C633 which duplicates the voltage to the base of Q635. The multivibrator is now stable and switches at about 2 or 3  $\mu$ s intervals.

When the MODE switch is set to ALT, the circuit is a monostable multivibrator. In the quiescent state, Q625 is reverse biased and Q635 forward biased. A positive pulse applied to the base of Q625 will cycle the circuit.

Each time the driver multivibrator cycles, pulses are coupled through T621 to the switching multivibrator. With the MODE switch in CHOP or ALT, the CRT display alternates between channel 1 and channel 2 at the driver multivibrator cycling rate. In CHOP mode, the channel switching rate is 2 to 3  $\mu$ s. In ALT mode, the channel switching rate is

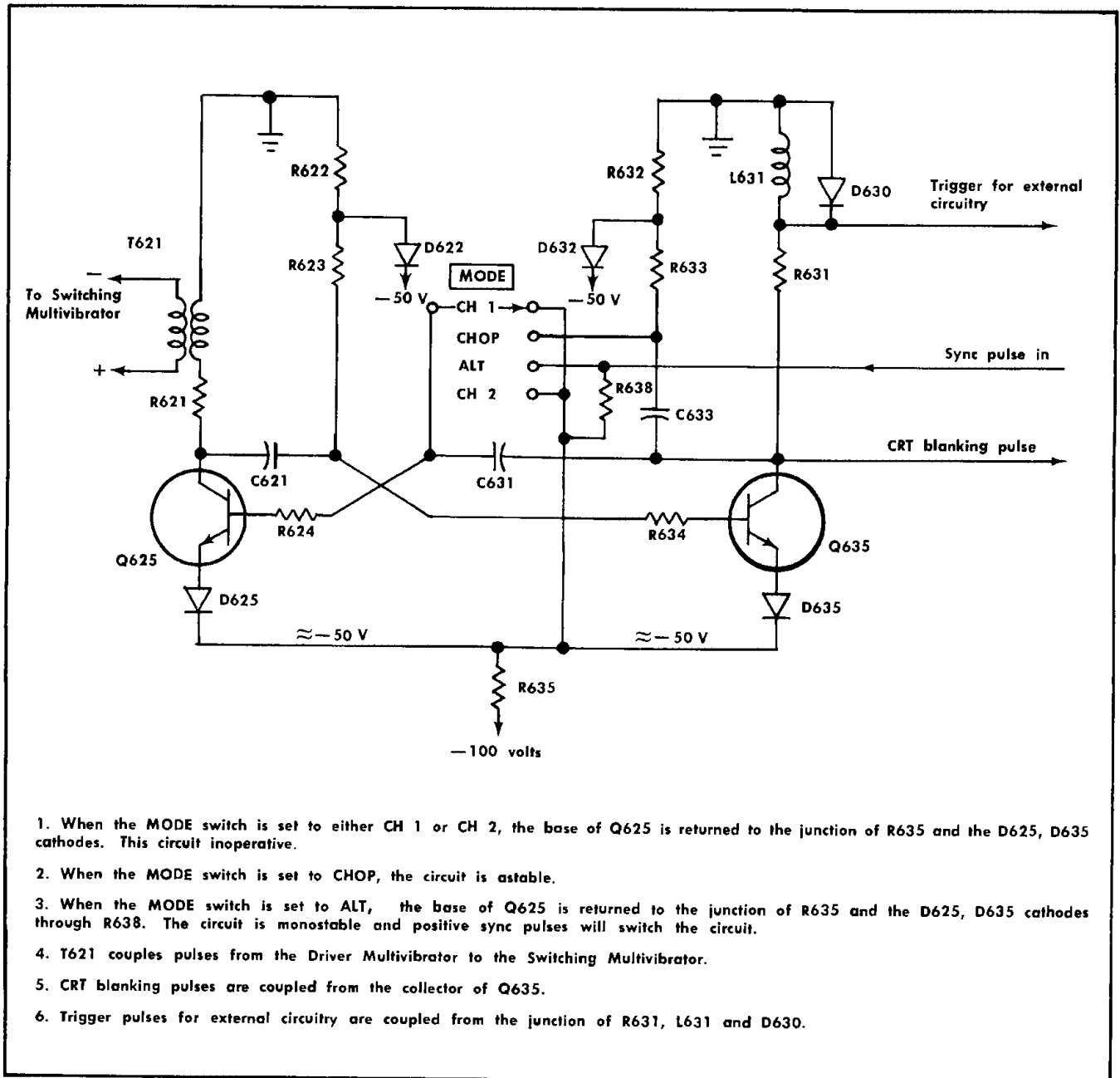


Fig. 3-11. Partial diagram showing the Driver Multivibrator.

determined by the pulse of the external signal used to cycle the driver multivibrator.

D625 and D635 provide base-to-emitter reverse-bias breakdown protection.

### Output Amplifier

The output amplifier is common to both channel input amplifiers and is connected to the output of one channel or the other by means of the switching circuit. The ampli-

fier provides the gain and power output to drive the CRT deflection plates with a high impedance push-pull signal. See Fig. 3-12.

Q644 and Q654 plus their circuitry convert output signal current, from the channel amplifier output stage, to signal voltage to drive the output amplifier stage.

The output amplifier contains emitter followers driving two cascode amplifiers with their input sections sharing a common emitter circuit. Gain of the stage is set by the plate-to-emitter load impedance ratio which can be calibrated by the front panel GAIN adjustment R665.

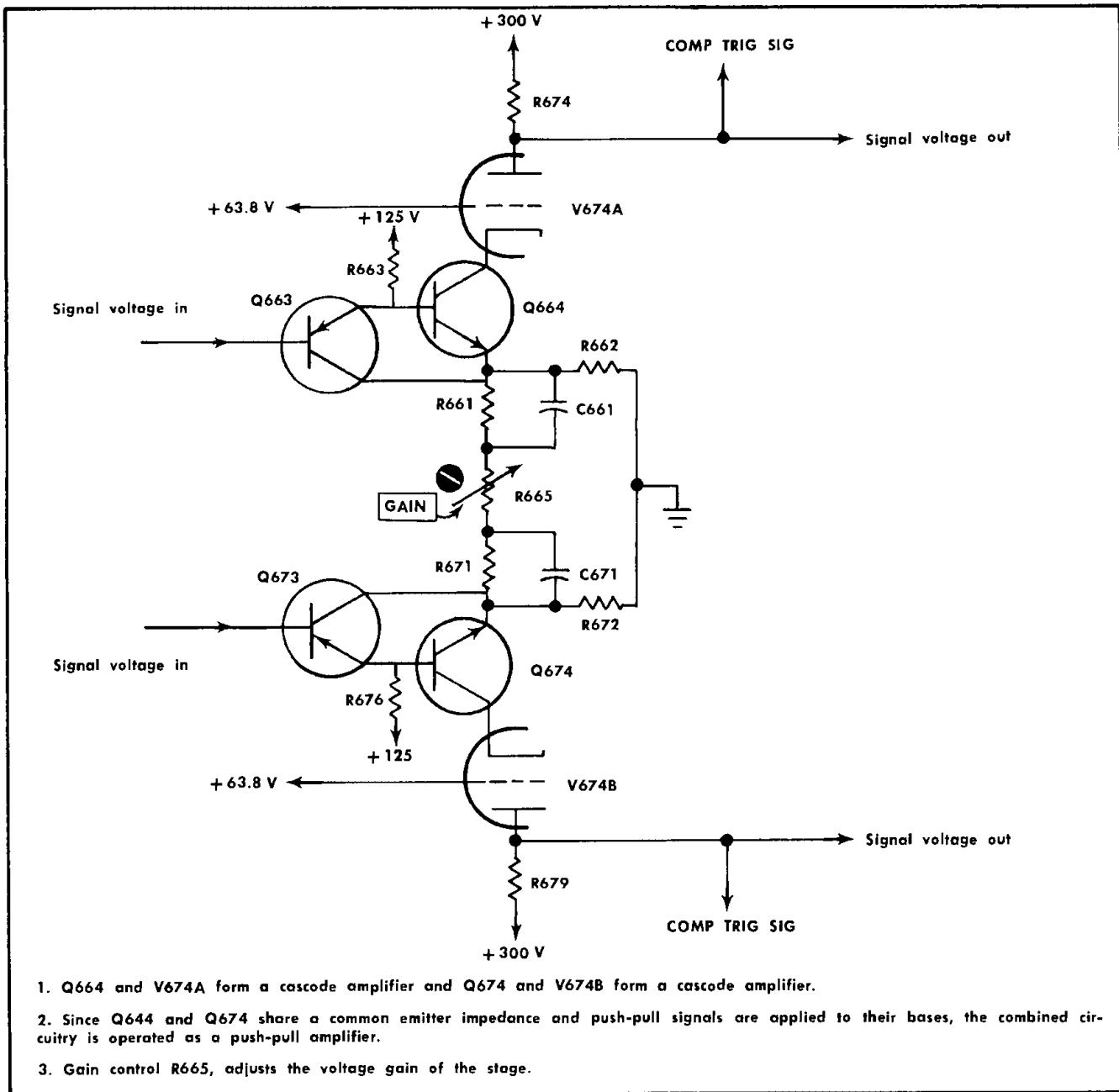


Fig. 3-12. Partial diagram showing the Output Amplifier.

Q663 and Q673 stabilize the gain of the amplifier over a temperature range and increase the apparent input impedance to the cascode amplifier.

A composite trigger signal (output signal) is available to the trigger amplifier circuit at the plates of V674A and V674B.

### Trigger Circuit

The trigger circuit contains a trigger DC level adjustment circuit for each selection of the TRIGGER selector, a trigger amplifier for each channel and two output cathode follow-

ers. The circuit provides three selections of trigger information, channel 1 (CH 1), composite (COMP) and channel 2 (CH 2). The DC reference level of the output trigger signals is adjustable to zero volts. The output of the circuit is applied through the plug in connector (P11) to provide a companion time base unit with internal trigger information.

When the TRIGGER switch is set to either CH 1 or CH 2 positions, the input to the cathode followers V583A-V583B, are connected through a coupling circuit to the output of the selected trigger amplifiers Q504, Q514 or Q534, Q544. Since the trigger amplifiers are driven by signals from their respective input amplifiers, the output trigger signal of the

Circuit Description—Type 3A3

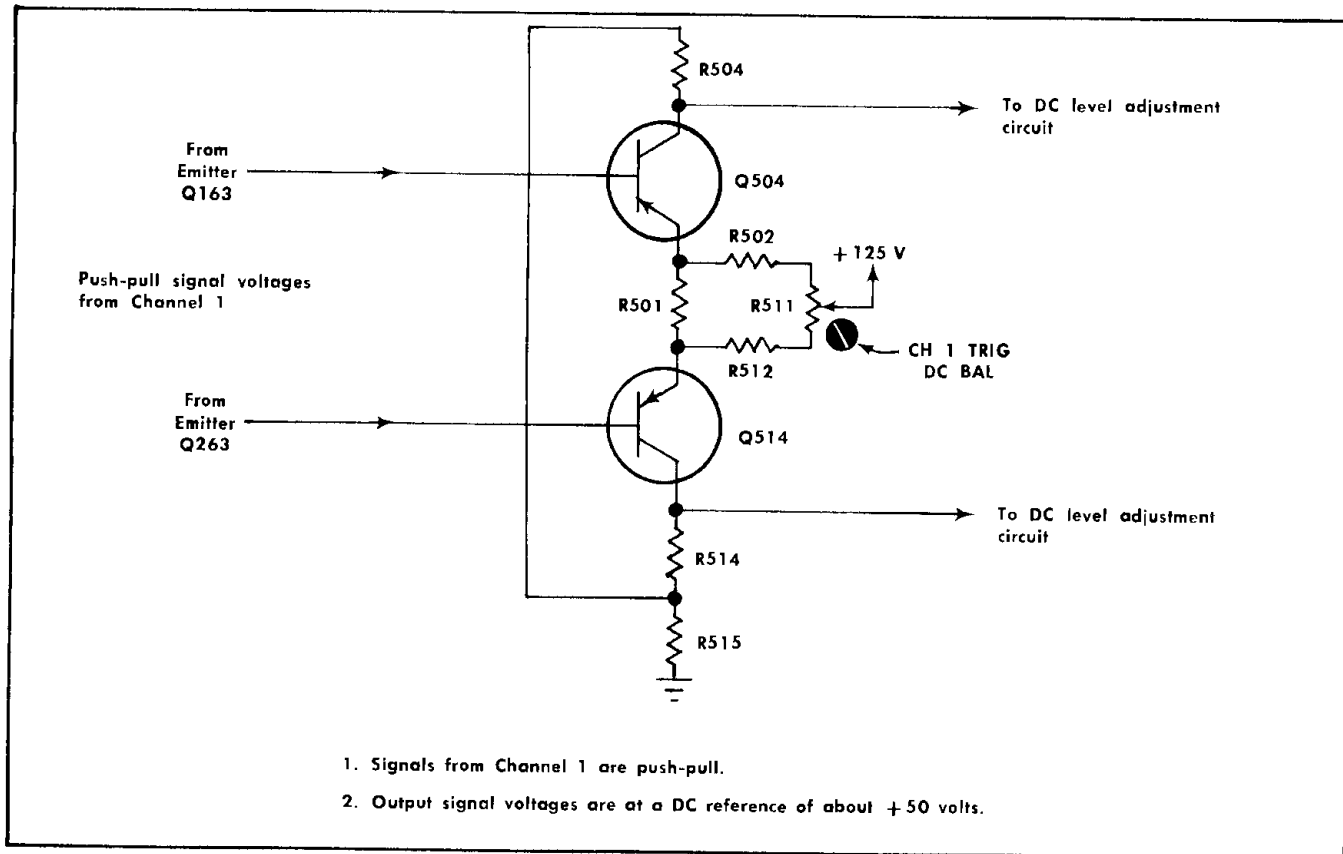


Fig. 3-13. Partial diagram showing the Channel 1 Trigger Amplifier.

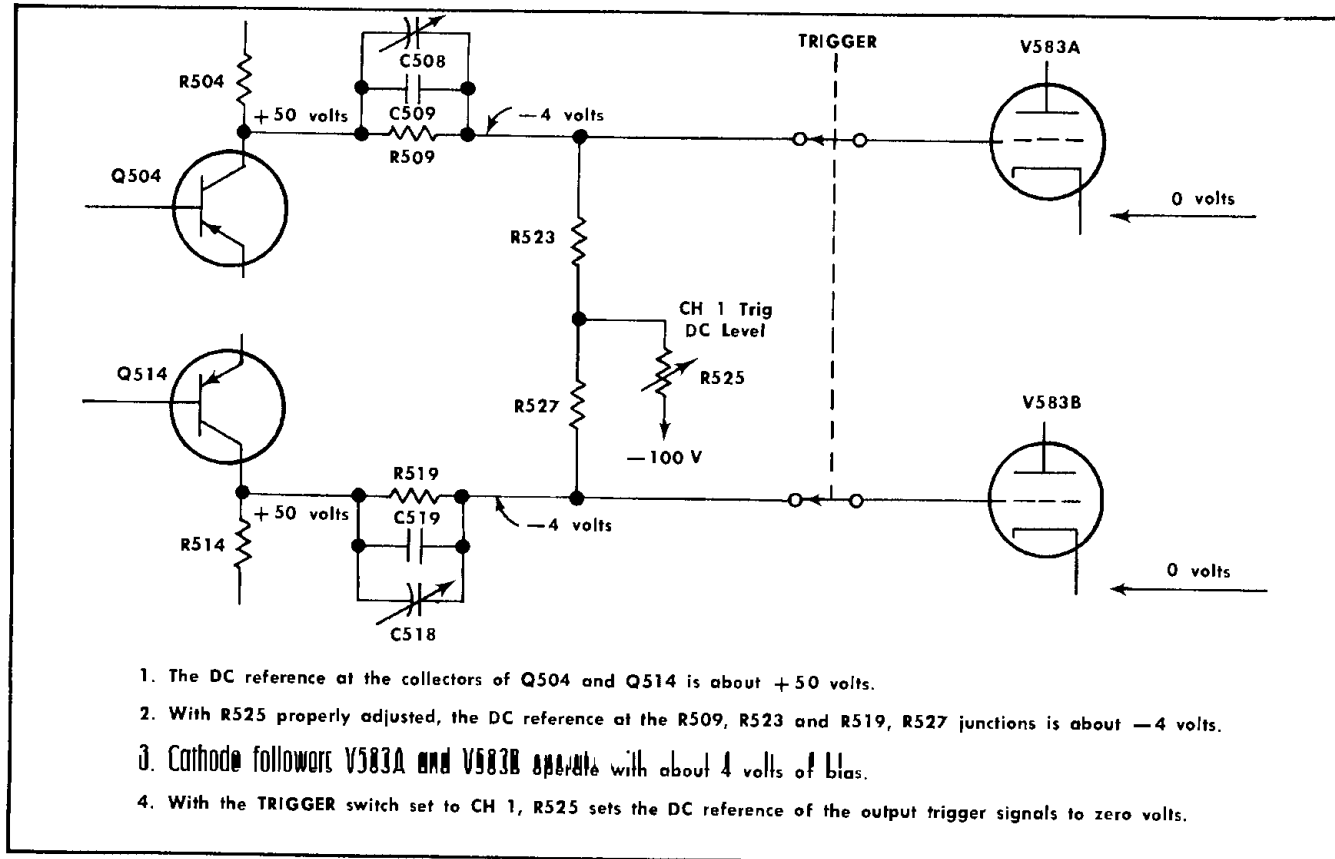


Fig. 3-14. Partial diagram showing the Channel 1 Trigger DC Level adjustment circuit.



common cathode followers originate from the selected channel. The DC level of each trigger amplifier is balanced by adjustments R525 and R555.

When the COMP position is selected, the input to the cathode followers is coupled to the plates of V674 in the output amplifier. Since the drive to the output amplifier is a function of the MODE switch setting, the origin of the trigger signals is the channel that is displayed. The DC level of the trigger signal to the time base unit is again set by the Comp Trig DC Level R565.

Q504 and Q514 with their associated circuitry form the channel 1 trigger amplifier (Fig. 3-13). The circuit is a conventional emitter coupled amplifier operated push-pull. The constant DC operating current of the circuit is set and balanced by returning the emitters to +125 volts through R502 and CH 1 Trig DC Bal adjustment R511.

Push-pull signal voltages from the channel 1 emitter followers, Q163 and Q263, are coupled to the bases of Q504 and Q514. The amplifier push-pull signal voltage at the collectors of Q504 and Q514 is at a DC level of about +50 volts.

A trigger DC Level adjustment circuit for each trigger selection provides a means of setting the DC output reference voltage at the cathodes of V583 to zero volts. A voltage divider network to the -100 volt supply that includes the respective CH or Comp Trig DC Level adjustments R525, R555 or R565, sets the DC level at the grids of the cathode follower V583, so the output level at the cathodes is 0V. See Fig. 3-14.

High frequency compensation is provided by adjustments C508 and C518 for CH 1, C538 and C548 for CH 2, C561 and C569 for the composite signal.



# SECTION 4

## MAINTENANCE

Change information, if any, affecting this section will be found at the rear of the manual.

### Introduction

This section for the manual contains information for use in preventive maintenance, corrective maintenance or troubleshooting of the Type 3A3.

### PREVENTIVE MAINTENANCE

#### General

Preventive maintenance consists of cleaning, visual inspection, lubrication, etc. Preventive maintenance performed on a regular basis may prevent instrument breakdown and will improve the reliability of this instrument. The severity of the environment to which the Type 3A3 is subjected will determine the frequency of maintenance. A convenient time to perform preventive maintenance is preceding recalibration of the instrument.

#### Cleaning

The Type 3A3 should be cleaned as often as operating conditions require. Accumulation of dirt in the instrument can cause overheating and component breakdown. Dirt on components acts as an insulating blanket and prevents efficient heat dissipation. It also provides an electrical conduction path.

The covers of the indicator oscilloscope minimize the amount of dust which reaches the interior of the Type 3A3. Operation of the system without the covers in place necessitates more frequent cleaning. When the Type 3A3 is not in use, it should be stored in a protected location such as a dust-tight cabinet.

#### CAUTION

**Avoid the use of chemical cleaning agents which damage the plastics used in this instrument. Avoid chemicals which contain benzene, toluene, xylene, acetone or similar solvents.**

**Exterior.** Loose dust accumulated on the front panel of the Type 3A3 can be removed with a soft cloth or small paint brush. The paint brush is particularly useful for dislodging dirt on and around the front-panel controls. Dirt which remains can be removed with a soft cloth dampened with a mild detergent and water solution. Abrasive cleaners should not be used.

**Interior.** Dust in the interior of the unit should be removed due to its electrical conductivity under high-humidity conditions. To clean the interior, blow off the accumulated dust with dry low-velocity air. Remove any remaining dirt

with a soft paint brush or cloth dampened with a mild detergent and water solution. A cotton-tipped applicator is useful for cleaning in narrow spaces or to clean ceramic terminal strips and circuit boards.

#### Lubrication

The reliability of potentiometers, rotary switches and other moving parts is maintained if they are properly lubricated. Use a cleaning-type lubricant (e.g., Tektronix Part No. 006-0218-00) on shaft bushings and switch contacts. Lubricate switch detents with a heavier grease (e.g., Tektronix Part No. 006-0219-00). Potentiometers which are not permanently sealed should be lubricated with a lubricant which will not affect electrical characteristics (e.g., Tektronix Part No. 006-0220-00). Do not over-lubricate. A lubrication kit containing the necessary lubricants and instructions is available from Tektronix, Inc. Order Tektronix Part No. 003-0342-00.

#### Visual Inspection

The Type 3A3 should be inspected occasionally for such defects as broken connections, broken or damaged ceramic strips, improperly seated transistors, damaged circuit boards and heat-damaged parts.

The corrective procedure for most visible defects is obvious; however, particular care must be taken if heat-damaged components are found. Overheating usually indicates other trouble in the instrument; therefore, it is important that the cause of over-heating be corrected.

#### Tube and Transistor Checks

Periodic preventive maintenance checks on the tubes and transistors are not recommended. The circuits within the unit generally provide the most satisfactory means of checking tube or transistor usability. Performance of the circuits is thoroughly checked during recalibration, and substandard tubes and transistors will usually be detected at that time. More details are provided in the Troubleshooting portion of this section.

#### Recalibration

To assure accurate measurements, check the calibration of this instrument after each 1000 hours of operation or every six months if used infrequently. In addition, replacement of components may necessitate recalibration of the affected circuits. Complete calibration instructions are given in the Calibration section.

## Maintenance—Type 3A3

The calibration procedure can also be helpful in localizing certain troubles in the instrument. In some cases, minor troubles may be revealed and/or corrected by recalibration.

### CORRECTIVE MAINTENANCE

#### General

Corrective maintenance consists of component replacement and instrument repair. Special techniques required to replace components in this instrument are given here.

#### Obtaining Replacement Parts

**Standard Parts.** All electrical and mechanical part replacements for the Type 3A3 can be obtained through your local Tektronix Field Office or representative. However, many of the standard electronic components can be obtained locally in less time than is required to order them from Tektronix, Inc. Before purchasing or ordering replacement parts, check the parts list for value, tolerance, rating and description.

#### NOTE

When selecting replacement parts, it is important to remember that the physical size and shape of a component may affect its performance in the instrument, particularly at high frequencies. All replacement parts should be direct replacements unless it is known that a different component will not adversely affect instrument performance.

**Special Parts.** In addition to the standard electronic components, some special parts are used in the Type 3A3. These parts are manufactured or selected by Tektronix, Inc. to meet specific performance requirements, or are manufactured for Tektronix, Inc. in accordance with our specifications. These special parts are indicated in the parts list by an asterisk preceding the part number. Most of the mechanical parts used in this instrument have been manufactured by Tektronix, Inc. Order all special parts directly from your local Tektronix Field Office or representative.

#### Soldering Techniques

##### WARNING

Disconnect the instrument from the power source before soldering.

**Circuit Boards.** Use ordinary 60/40 solder and a 35- to 40-watt pencil type soldering iron on the circuit boards. The tip of the iron should be clean and properly tinned for best heat transfer to the solder joint. A higher wattage soldering iron may separate the etched wiring from the base material.

The following technique is suggested for replacing a component on a circuit board.

##### Removal:

1. Grip one lead of the component with long-nose pliers. Touch the soldering iron to the lead at the solder connection. Do not lay the iron directly on the board as it may damage the board.

2. When the solder begins to melt, pull the lead out quickly but gently. This should leave a clean hole in the board. If not, the hole can be cleaned by reheating the solder and placing a sharp object such as a toothpick into the hole to clean it out.

##### Installation:

1. Bend the leads of the new component to fit the holes in the board. If the component is replaced while the board is mounted in the instrument, cut the leads long enough so they just protrude through the board. Insert the leads into the holes in the board so the component is firmly seated against the board (or as positioned originally). If it does not seat properly, heat the solder and gently press the component into place.

2. Touch the iron to the connection and apply a small amount of solder to make a firm solder joint. To protect heat-sensitive components, hold the lead between the component body and the solder joint with a pair of needle-nose pliers or other heat sink.

3. Clip the excess lead that protrudes through the board.

4. Clean the area around the solder connection with a flux-remover solvent. Be careful not to remove information printed on the board.

**Ceramic Terminal Strips.** Solder used on the ceramic terminal strips should contain about 3% silver. Use a 40- to 75-watt soldering iron with a 1/8-inch wide wedge-shaped tip. Ordinary solder can be used occasionally without damage to the ceramic terminal strips. However, if ordinary solder is used repeatedly or if excessive heat is applied, the solder-to-ceramic bond may be broken.

Solder containing 3% silver is usually available locally or it can be purchased from Tektronix in one-pound rolls; order by Tektronix Part No. 251-0514-00.

Observe the following precaution when soldering to ceramic terminal strips:

1. Use a hot iron for a short time. Apply only enough heat to make the solder flow freely.

2. Maintain a clean, properly tinned tip.

3. Avoid putting pressure on the ceramic terminal strip.

4. Do not attempt to fill the terminal-strip notch with solder; use only enough solder to cover the wires adequately.

5. Clean the flux from the terminal strip with a flux-remover solvent.

**Metal Terminals.** When soldering metal terminals (e.g., switch terminals, potentiometers, etc.), ordinary 60/40 solder can be used. Use a soldering iron with a 40- to 75-watt rating and a 1/8-inch wide wedge-shaped tip.

Observe the following precautions when soldering metal terminals:

1. Apply only enough heat to make the solder flow freely.

2. Apply only enough solder to form a solid connection. Excess solder may impair the function of the part.

3. If a wire extends beyond the solder joint, clip off the excess.

4. Clean the flux from the solder joint with a flux-remover solvent.

## Component Replacement

### WARNING

Disconnect the instrument from the power source before replacing components.

**Ceramic Terminal Strip Replacement.** A complete ceramic terminal strip assembly is shown in Fig. 4-1. Replacement strips (including studs) and spacers are supplied under separate part numbers. However, the old spacers may be re-used if they are not damaged. The applicable Tektronix Part Numbers for the ceramic strips and spacers used in this instrument are given in the Mechanical Parts List.

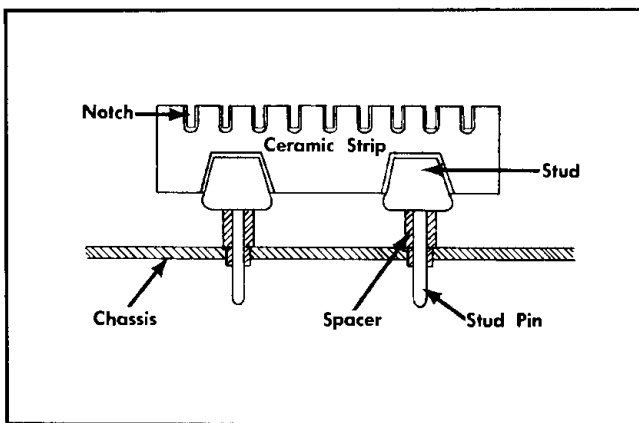


Fig. 4-1. Ceramic terminal strip assembly.

To replace a ceramic terminal strip, use the following procedure:

#### Removal:

1. Unsolder all components and connectors on the strip. It may be advisable to mark each lead or draw a sketch to show location of the components and connections as an aid in replacing the wires and components on a new strip.

2. Pry or pull the damaged strip from the chassis.

3. If the spacers come out with the strip, remove them from the stud pins. (Spacers should be replaced if they are damaged.)

#### Replacement:

1. Place the spacers in the chassis holes.

2. Carefully press the studs of the strip into the spacers until they are completely seated. If necessary, use a soft mallet and tap lightly, directly over the stud, to seat the strip completely.

3. If the stud extends through the spacers, cut off the excess.

4. Replace all components and connections. Observe the soldering precautions given under Soldering Techniques in this section.

**Circuit Board Replacement.** If a circuit board is damaged and cannot be repaired, it should be replaced with a new circuit board assembly. Part numbers for circuit boards with the circuit components wired in place are given in the Mechanical Parts List.

When it becomes necessary to remove a circuit board, remove the associated VOLTS/DIV switch and the circuit board as a unit. The VOLTS/DIV switch and the circuit board may then be separated by unsoldering the leads between them and removing the holding screws.

The Input Amplifier circuit board is mounted in place with four clips. To remove the board, spread the clips and lift out the board. Unplug the square pin connectors if the board is to be replaced. Locations of the components on the circuit boards are shown in Fig. 4-4 through 4-6. Fig. 4-6 also shows the wire color code for the square pin connectors to the Input Amplifier board.

**Rotary Switches.** Individual wafers, mechanical parts or rotary switches are normally not replaced. If a switch is defective, replace the entire assembly. Switches can be ordered either wired or unwired; refer to the Parts List for the applicable part numbers.

When replacing a switch, tag the leads and switch terminals with corresponding identification tags as the leads are disconnected. Then, use the old switch as a guide for installing the new one. A sketch of the switch layout and record of the wire color at each terminal is also helpful. When soldering to the new switch be careful that the solder does not flow beyond the rivets on the switch terminals. Spring tension of the switch contact can be destroyed by excessive solder.

**AC-GND-DC and Toggle Switches.** If an AC-GND-DC switch or a toggle switch is defective, replace the switch. Part numbers for replacement switches are given in the Mechanical Parts List.

To gain access to the AC-GND-DC switches, remove the input circuit shield.

## Recalibration After Repair

After an electrical component has been replaced, the calibration of that particular circuit should be checked, as well as the calibration of other closely related circuits. The Performance Check procedure in Section 5 provides a quick and convenient means of checking instrument operation.

## TROUBLESHOOTING

This portion is provided to aid in locating and correcting trouble in the Type 3A3. Information contained in the Circuit Description, the Calibration Procedure and the schematic diagrams is also helpful when troubleshooting the instrument.

**Troubleshooting Aids**

**Diagrams.** Block and circuit diagrams are contained in the pullout pages in Section 9. The circuit diagrams contain component circuit numbers, voltages and waveforms. Conditions under which the voltages and waveforms were taken are also indicated on the inside portion of the CH 1 Input Amplifier 1, pullout page.

**Switch Wafer Identification.** Switch wafers shown on the diagrams are coded to indicate the position of the wafer in the complete switch assembly. The numbered portion of the code refers to the wafer number counting from the front, or mounting end of the switch, toward the rear. The letters F and R indicate whether the front or rear of the wafer performs the particular switching function. For example, a wafer designated 2R indicates that the rear of the second wafer is used for this particular switching function.

**Wiring Color Code.** All insulated wires used in the Type 3A3 are color-coded according to the EIA standard color code (as used for resistors) to facilitate circuit tracing. The widest color stripe identifies the first color of the code.

Power-supply voltages can be identified by three color stripes and the following background color-code; white, positive voltage; tan, negative voltage; gray, unregulated voltage.

Table 4-1 shows the wiring color code for the power-supply voltages using insulated wires for interconnections in the Type 3A3.

**TABLE 4-1**  
Power Supply Wiring Color-Code

Supply	Back-ground Color	1st Stripe	2nd Stripe	3rd Stripe
+300 volt	white	orange	black	brown
+125 volt	white	brown	red	brown
-12.2 volt	tan	brown	red	black
-100 volt	tan	brown	black	brown

**Resistor Color-Code.** In addition to the brown composition resistors, some metal-film resistors (identifiable by their gray or blue body color) and some wire-wound resistors (usually light blue or gray-green) are used in the Type 3A3. The resistance values of wire-wound resistors are printed on the body of the component. The resistance values of composition resistors and metal-film resistors may have the value indicated on the body by means of the EIA color code. The color code is read starting with the stripe nearest the end of the resistor. Composition resistors have four stripes which consist of two significant figures, a multiplier and a tolerance value (Fig. 4-2). Metal-film re-

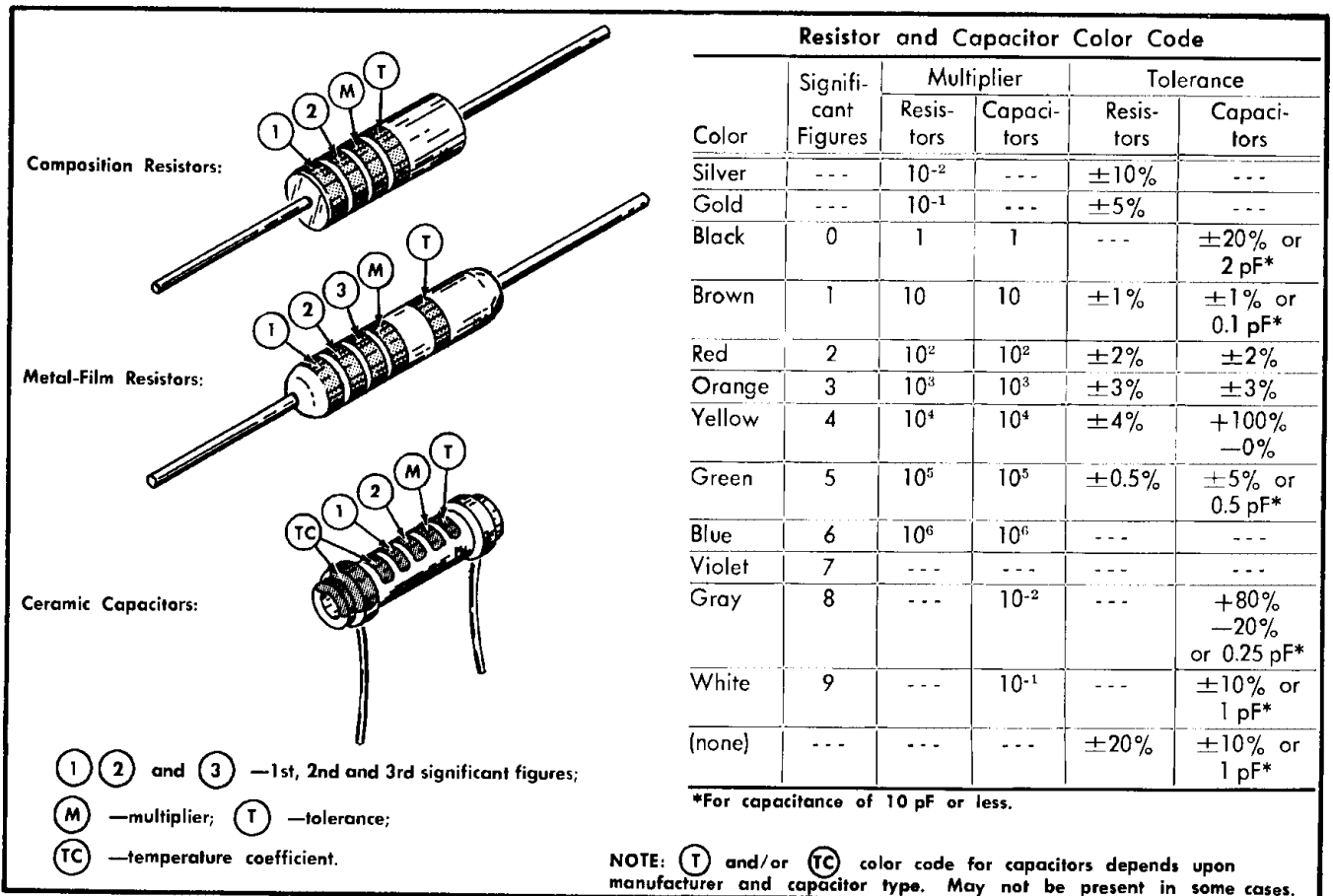


Fig. 4-2. Color-code for resistors and ceramic capacitors.

sistors have five stripes consisting of three significant figures, a multiplier and a tolerance value.

**Capacitor Marking.** The capacitance values of common disc capacitors and small electrolytics are marked in microfarads on the side of the component body. The white ceramic capacitors used in the Type 3A3 are color coded in picofarads using a modified EIA code (Fig. 4-2).

**Diode Color Code.** The cathode end of each glass-encased diode is indicated by a stripe, a series of stripes or a dot. For most silicon or germanium diodes with a series of stripes, the color-code also indicates the type of diode. The cathode and anode end of metal-encased diodes can be identified either by the diode symbol marked on the body or by the flared end at the anode. (Fig. 4-7 shows the location of all the diodes.)

**Suggested Test Equipment for Troubleshooting**

(1) Transistor Tester

Description: Tektronix Type 575 Transistor-Curve Tracer.

Purpose: Test semiconductors used in the Type 3A3.

(2) VOM

Description: 20,000  $\Omega/V$ . Be sure the test probes are suitable for use in tight places to prevent accidental shorting.

Purpose: General troubleshooting.

(3) Test Oscilloscope

Description: Bandwidth, DC to 10 MHz or higher. Calibrated vertical deflection factors down to 5 mV/div with a 1 $\times$  probe. Additional feature, but not required: The vertical amplifier should have a differential input; if it does, a second 1 $\times$  probe is needed.

Purpose: Low-frequency signal tracing and voltage measurements.

(4) Flexible Cable Plug-In Extension

Description: 30 inches long, Tektronix Part No. 012-0038-00.

Purpose: Permits operating the Type 3A3 out of the oscilloscope plug-in compartment for better accessibility.

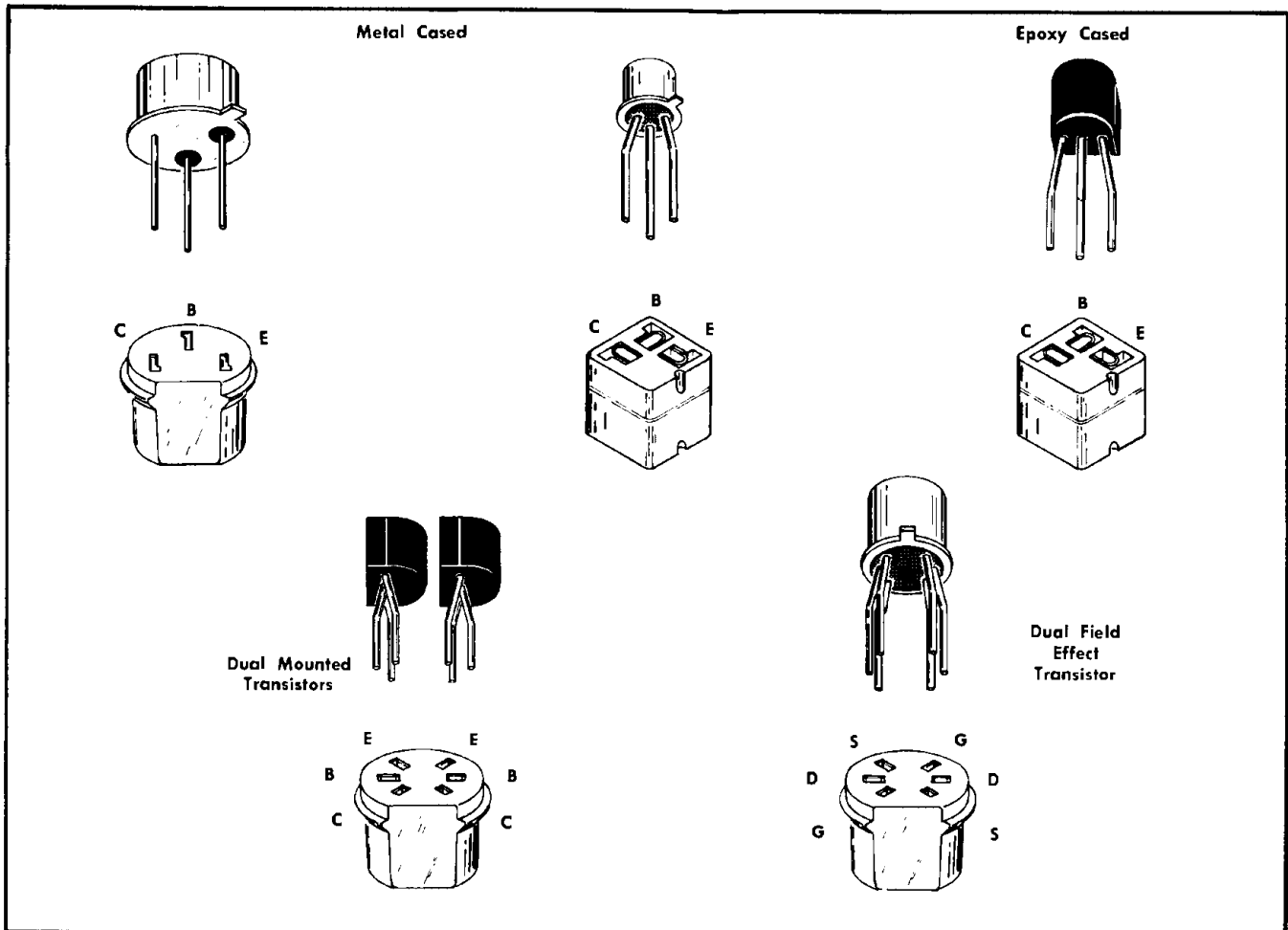


Fig. 4-3. Transistor socket and transistor lead configuration top view.

## Maintenance—Type 3A3

### (5) BNC Coaxial Cables (two required)

Description: Equipped with BNC plug connectors on each end. Tektronix Part No. 012-0057-00.

Purpose: Use in low-frequency signal-tracing setup to apply the oscilloscope calibrator signal to the Type 3A3 and to the test oscilloscope Ext Trig input connector.

### (6) BNC T Connector

Description: Fits one BNC jack and two BNC plugs. Tektronix Part No. 103-0030-00.

Purpose: Use in a low-frequency signal tracing setup for connecting to the two BNC coaxial cables (item 5) and to the Cal Out connector on the oscilloscope used with the Type 3A3.

### (7) Miscellaneous: Replacement tubes, transistors and diodes.

## Troubleshooting Checks

If an apparant trouble occurs in the Type 3A3, consider the following preliminary checks before proceeding with the more extensive troubleshooting procedures.

**Check Control Settings.** Incorrect control settings can give a component malfunction indication even though all components are functioning properly. Check the setting of each front panel control and screwdriver adjustment. If there is a question about the purpose or use of a control, review the operating instructions in Section 2 of this manual.

**Check Associated Instruments.** Substitution of plug-in units will usually isolate the malfunctioning instrument.

1. Check for correct supply and internal DC voltages, as listed in Table 4-2 and shown in the schematic section. To perform this check the Type 3A3 must be connected via a flexible plug-in extension to the oscilloscope.

TABLE 4-2

Supply and Internal DC Voltages

Check Point	DC Voltages and Tolerance
Amphenol connector pin 10	+300 V; $\pm 9$ V
Amphenol connector pin 15	+125 V; $\pm 3.7$ V
Amphenol connector pin 16	-12.2 V; $\pm 0.37$ V
Amphenol connector pin 23	-100 V; $\pm 3$ V
R699-D699 junction	-50 V; $\pm 1.5$ V
R689-D689 junction	+63.8 V; $\pm 1.9$ V
D688-D687 junction	+65 V; $\pm 1.9$ V
D687-Q684 emitter junction	+75 V; $\pm 2.2$ V

2. Check the performance of the instrument. The performance check listed in Section 5 of this manual provides a check of each circuit within the Type 3A3 and will often indicate the circuit has the malfunction.

When the trouble has been isolated to a particular circuit, the following procedures are useful for locating the malfunctioning component.

**Visual Check.** Visually check the portion of the instrument in which the trouble is located. Many troubles can be located by visual indications such as unsoldered connections, broken wires, damaged circuit boards, damaged components, etc.

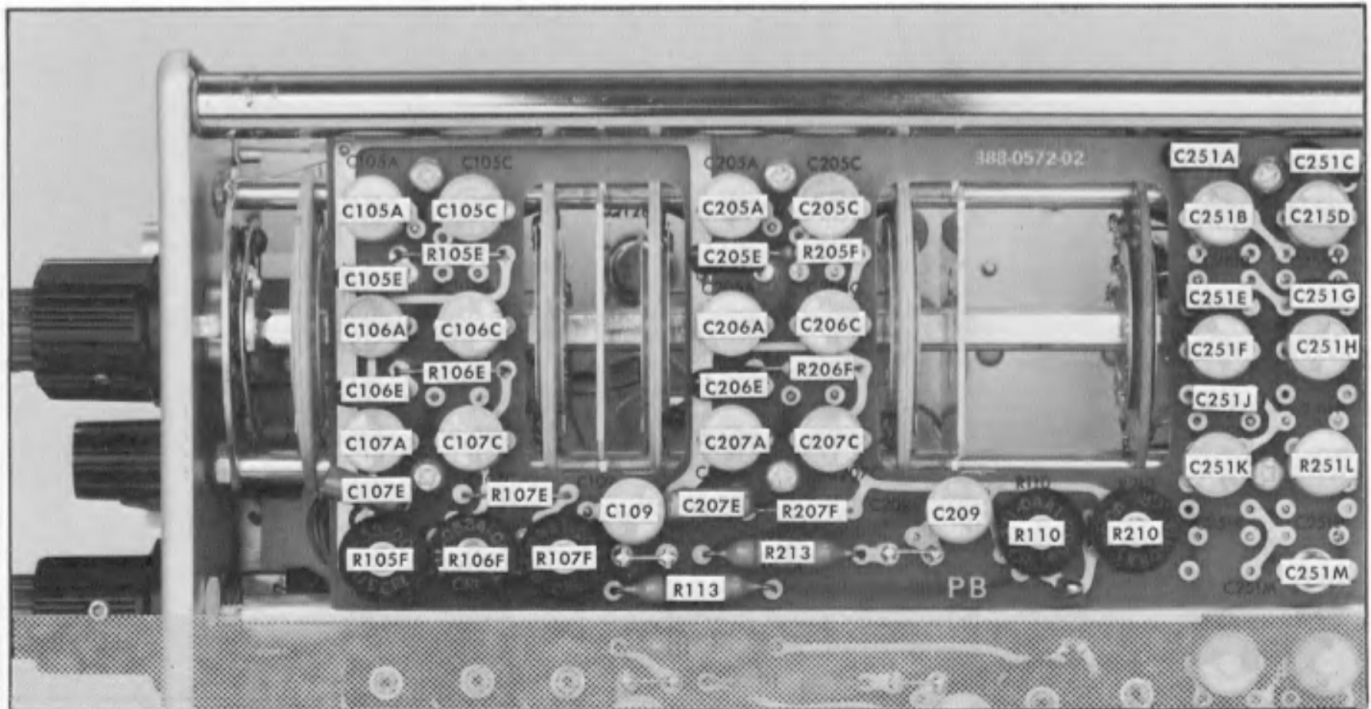


Fig. 4-4. Identification of unmarked components located on the CH 1 Input Attenuator circuit board.



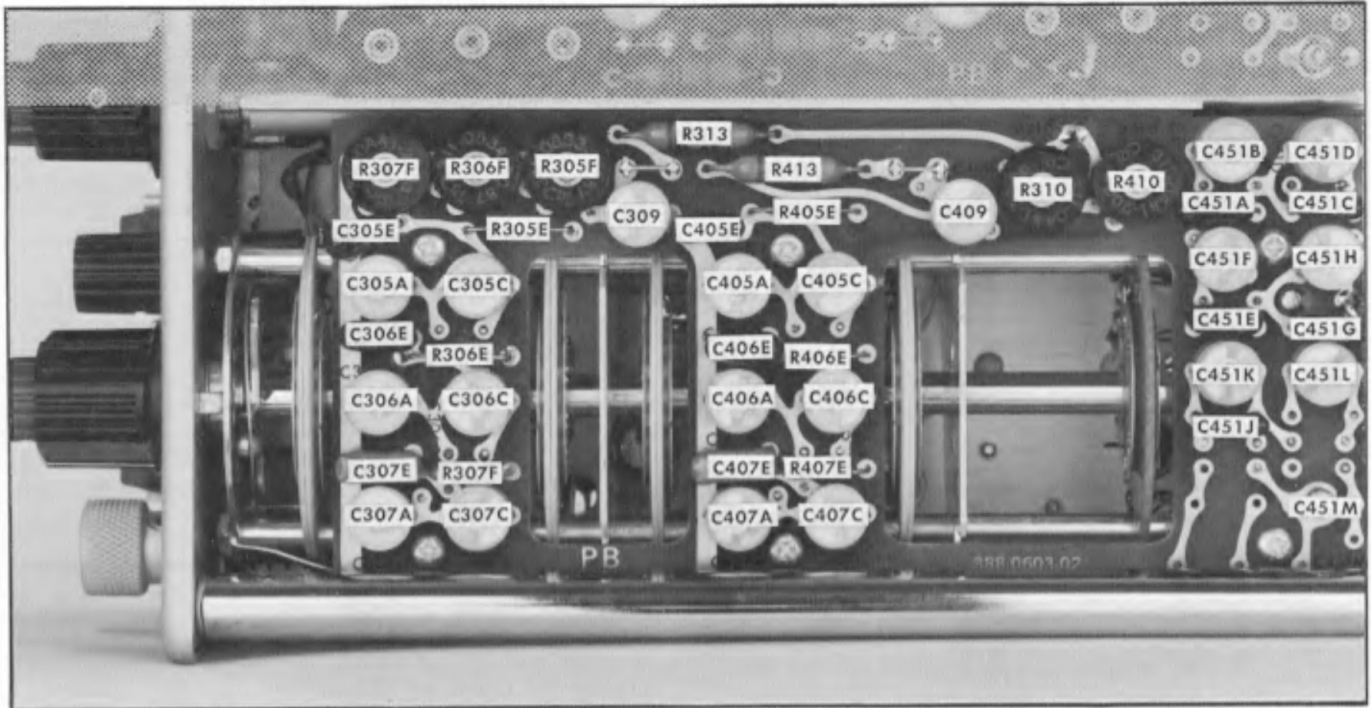


Fig. 4-5. Identification of the unmarked components located on the CH 2 Input Attenuator.

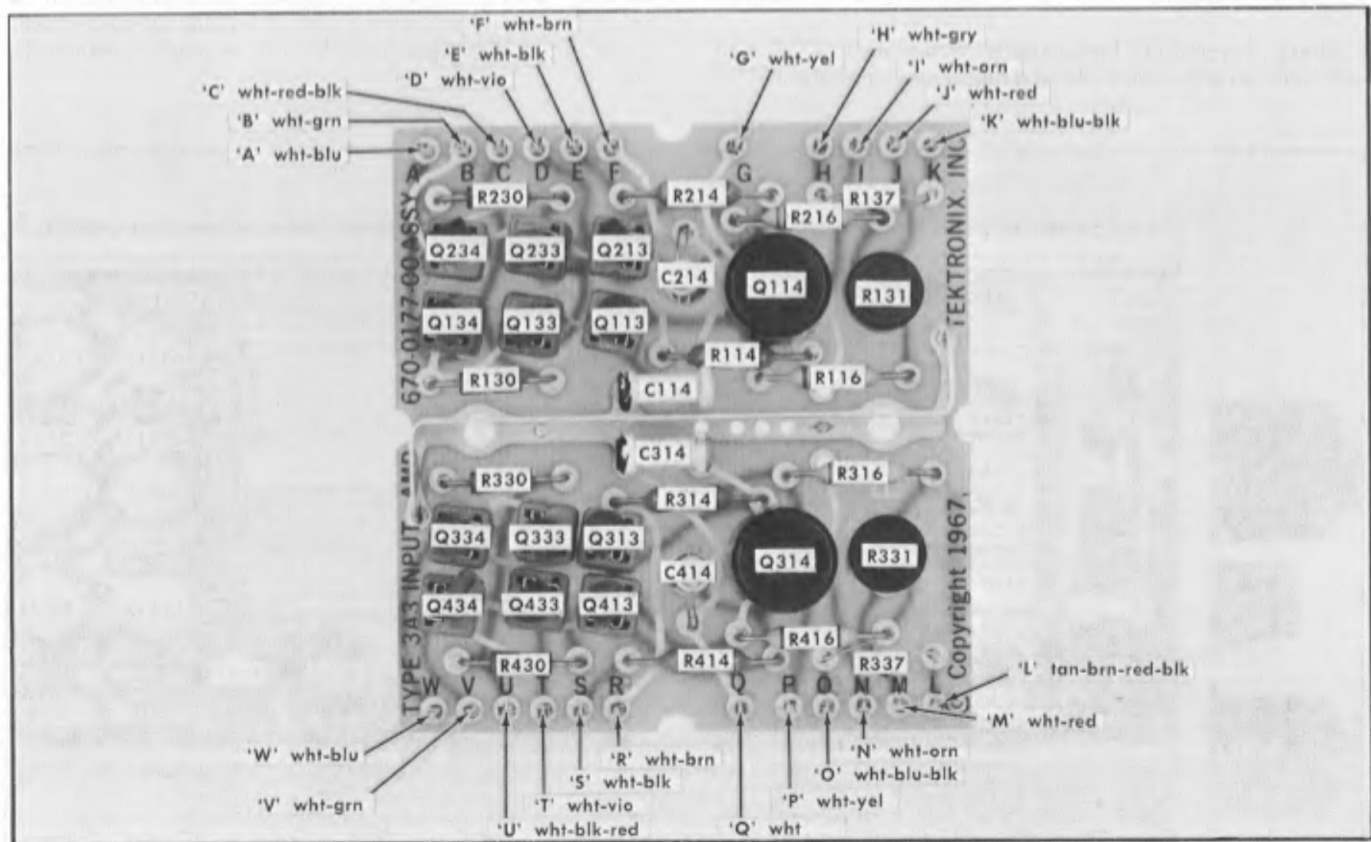


Fig. 4-6. Input amplifier board. Component location and wire color code to square pin connectors.

**Check Voltages and Waveforms.** Often the defective component can be located by checking for correct voltages and waveforms in the circuit. Typical voltages and waveforms are given on the diagrams in Section 9.

**Tube and Transistor Substitution.** Tubes and transistors should not be replaced unless actually defective. However, temporary substitution is often the fastest and best way to detect a defective tube or transistor. Fig. 4-3 shows top and bottom views of the transistor and transistor sockets.

**NOTE**

Turn off the oscilloscope power before replacing transistors or tubes. The protective shield over the FET's Q114 and Q314, may be removed by pressing the cap to the side until it snaps past the lip on the transistor socket. When replacing the FET's the metal indexing tab normally faces the flat side of the socket. Transistor lead configuration and socket pin wiring are shown in Fig. 4-3.

Before substituting a FET or transistor, circuit conditions should be checked to insure that replacement will not damage the item. In some cases, these checks will also show whether the tube or transistor is thus proved acceptable, return it to its original socket to avoid unnecessary recalibration.

**In-Circuit Diode Checks**

In-circuit diode checks may be performed with a voltmeter. A comparison of the voltages on each side of the diode with the typical voltages listed on the diagram will help determine whether the diode is faulty. Forward-to-back resistance ratios can be checked by referring to the schematic and pulling appropriate tubes or transistors to remove low resistance loops around the diode.

**Isolating DC Imbalance**

To make the trace appear at the center of the CRT, the DC output voltage at pins 17 and 21 of the interconnecting plug must be essentially equal. To make the trace appear within the usable viewing area of the CRT, the DC voltage measured between pins 17 and 21 must be less than  $\pm 70$  volts.

The DC voltages at pins 17 and 21 of the interconnecting plug depend on the DC balance of each stage. Since all the amplifier stages are DC coupled, any excessive imbalance condition existing anywhere between input and output of the Type 3A3 can unbalance the output and cause the trace to be deflected out of the viewing area.

A procedure for isolating the cause of DC imbalance is as follows:

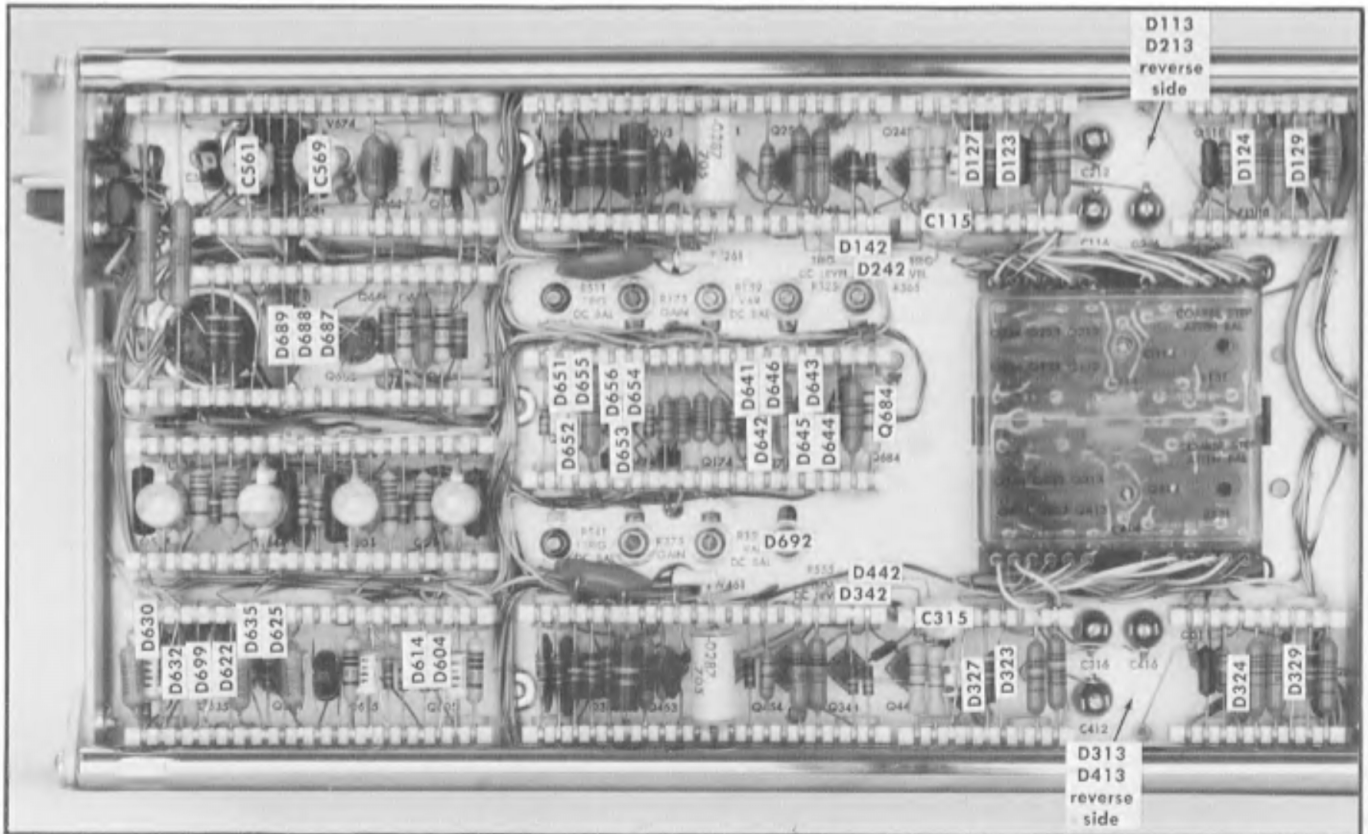


Fig. 4-7. Diodes and their locations.

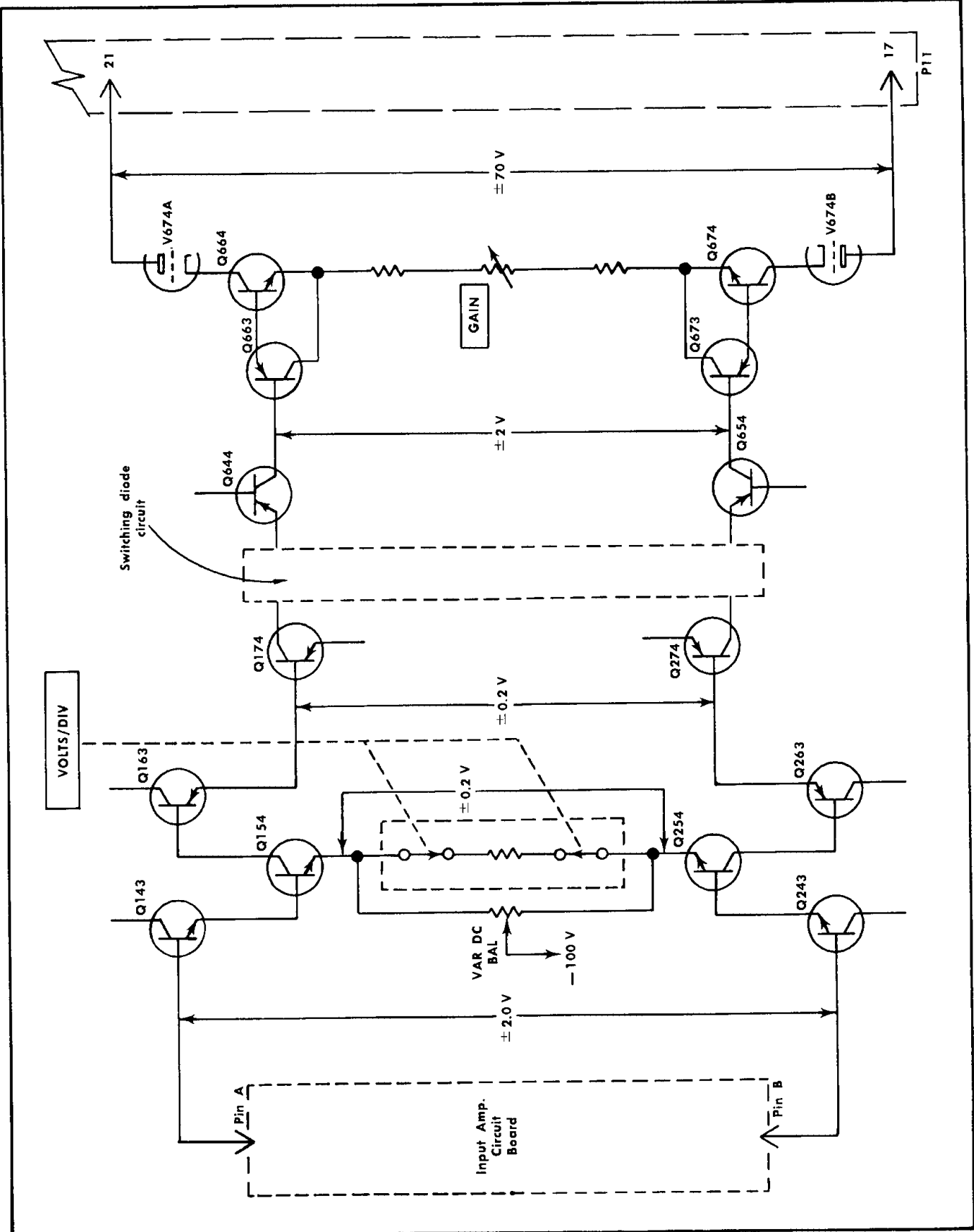


Fig. 4-8. Simplified diagram to show the approximate DC balance voltage limits at the indicated check points to position the trace within the graticule height.

## Maintenance—Type 3A3

1. Set the Type 3A3 front-panel controls at these positions:

VOLTS/DIV	10 mV
VARIABLE	CAL
POSITION	Midrange
AC-GND-DC (+ INPUT)	GND
AC-GND-DC (— INPUT)	GND
STEP ATTEN BAL	Midrange
GAIN	Midrange
MODE	To the channel to be checked

2. Connect a DC voltmeter (starting from the input) between corresponding points in the amplifier as shown in

Fig. 4-8 to determine the area where the imbalance originates. For example, with the voltmeter connected between the emitters of Q254 and Q154 and a reading within the limits indicated in the drawing, it may be assumed this stage is within the DC balance tolerance required to display a trace within the screen area.

Since both CH 1 and CH 2 input amplifiers drive the output amplifier through the diode switching circuit, it is logical to determine whether the trouble is common to both input amplifiers or only one. Once this has been determined checks may be made on individual circuits within the major block. These checks include voltage, waveform and resistance measurements.

After the trouble has been found and corrected, return to the Calibration section to check the calibration of the affected stage.

# SECTION 5

## PERFORMANCE CHECK

Change information, if any, affecting this section will be found at the rear of the manual.

### Introduction

This section provides a procedure for rapidly checking the performance of the Type 3A3. This procedure checks the operation of the instrument without removing the oscilloscope side covers or making internal adjustments. However, screwdriver adjustments located on the front panel are adjusted in this procedure.

If the instrument does not meet the performance requirements given in this procedure, internal checks and/or adjustments are required; see the Calibration section. All performance requirements given in this section correspond to those given in the Characteristics section.

### NOTE

All waveforms shown in this section are actual waveform photographs taken with a Tektronix Oscilloscope Camera System.

### Recommended Equipment

The following equipment is recommended for a complete performance check. Specifications given are the minimum necessary to perform this procedure. All equipment is assumed to be calibrated and operating within the given specifications. If equipment is substituted, it must meet or exceed the specifications of the recommended equipment.

For the most accurate and convenient performance check, special calibration fixtures are used in this procedure. These calibration fixtures are available from Tektronix, Inc. Order by part number through your local Tektronix Field Office or representative.

1. Calibration oscilloscope. Tektronix Type 561A recommended. Note: Any 560-series Oscilloscope (except the Type 560) may be substituted; however, if a Type 565 or RM565 Oscilloscope is used, the steps involving two Type 3A3 Plug-In Units in an X-Y configuration cannot be performed.

2. Time base plug-in. Tektronix 2B- or 3B-series Time Base Plug-In recommended. (Not required with Type 565 or RM565.)

3. (Optional) Vertical plug-in. Must be calibrated and match the Type 3A3 in gain and bandwidth characteristics. (Not required with Type 565 or RM565.) A second Type 3A3 is recommended.

4. Test oscilloscope. Required characteristics: Minimum deflection factor, 10 mV/division; bandwidth, from DC to 1 MHz. Tektronix Type 561A Oscilloscope with 3A-series vertical and 2B- or 3B-series horizontal Plug-In Unit.

5. Square-wave generator. Frequency, 1 kHz, 10 kHz and 100 kHz; risetime, 12 ns maximum; output impedance, 600 ohms or less (without an external termination); output amplitude, variable from about 0 volt to 10 volts peak to peak when terminated into 50 ohms. Tektronix Type 106 Square-Wave Generator recommended.

6. Low frequency sine-wave generator. Frequency, variable from below 2 Hz to above 500 kHz; output amplitude, variable from 1 volt to at least 20 volts peak to peak; amplitude regulation accuracy,  $\pm 1\%$ . For example, General Radio Model 1310A Oscillator.

7. Standard amplitude calibrator. Frequency, 1 kHz; output amplitude, 0.5 mV to 50 V peak to peak in a 1-2-5 step sequence; amplitude accuracy,  $\pm 0.25\%$ . Tektronix calibration fixture 067-0502-00 recommended.

8. Cable (two). Impedance, 50 ohm; length 42 inches; connectors, BNC. Tektronix Part No. 012-0057-01.

9. Cable. Impedance, 50 ohm; length, 5 ns; connectors, GR. Tektronix Part No. 017-0502-00.

10. Adapter. Connectors, BNC female to two banana plugs. Tektronix Part No. 013-0094-00.

11. Adapter. Connectors, GR to BNC male. Tektronix Part No. 017-0064-00.

12. Adapter. Connectors, BNC male to two BNC female. Tektronix Part No. 103-0030-00.

13. Adapter. Connectors, GR to BNC female. Tektronix Part No. 017-0063-00.

14. 2X attenuator. Impedance, 50 ohm; accuracy,  $\pm 3\%$ ; connectors, BNC. Tektronix Part No. 011-0069-00.

15. 5X attenuator (two). Impedance, 50 ohm; accuracy,  $\pm 3\%$ ; connectors, BNC. Tektronix Part No. 011-0060-00.

16. 10X attenuator (three). Impedance, 50 ohm; accuracy,  $\pm 3\%$ ; connectors, BNC. Tektronix Part No. 011-0059-00.

17. Input RC normalizer. Time constant, 1 megohm X 47 pF; attenuation, 2X; connectors, BNC. Tektronix Part No. 011-0068-00.

18. Termination. Impedance, 50 ohm; connectors, BNC; type, feed-thru; accuracy,  $\pm 3\%$ . Tektronix Part No. 011-0049-00.

19. Termination. Impedance, 50 ohm; connectors, GR to BNC male, type, feed-thru; accuracy,  $\pm 3\%$ . Tektronix Part No. 017-0083-00.

20. Dual-input coupler. Matched signal transfer to each input. Tektronix calibration fixture 067-0525-00 recommended.

## PERFORMANCE CHECK PROCEDURE

### General

In the following procedure, control settings or test equipment connections should not be changed except as noted. If only a partial check is desired, refer to the preceding step(s) for setup information. Type 3A3 front-panel control titles referred to in this procedure are capitalized (e.g., VOLTS/DIV).

The following procedure uses the equipment listed under Recommended Equipment. If equipment is substituted, control settings or setup may need to be altered to meet the requirements of the equipment used.

### Preliminary Procedure

1. Install the Type 3A3 into the vertical plug-in compartment of the calibration oscilloscope.
2. Install a 2B- or 3B-series plug-in into the horizontal plug-in compartment of the calibration oscilloscope.
3. Set the front-panel controls of the Type 3A3, calibration oscilloscope and horizontal plug-in as described below.

#### Type 3A3

VOLTS/DIV (both channels)	10 mV
VARIABLE (VOLTS/DIV) (both channels)	CAL
STEP ATTEN BALANCE (both channels)	As is
POSITION (both channels)	Midrange
+ Input Coupling (both channels)	GND
- Input Coupling (both channels)	GND
MODE	CH 1
TRIGGER	COMP
BANDWIDTH	500 kHz
GAIN	As is

#### Calibration Oscilloscope

Intensity	As desired
Focus	Adjusted for a well defined display
Astigmatism	Adjusted for a well defined display
Alignment	As desired
Calibrator	Off
Power	On
Scale Illum	As desired

#### 2B- or 3B-Series Plug-In

Calibration	Adjusted as per instruction manual procedure
-------------	--

Position	Midrange
Mode	Normal
Time/Div	0.5 ms
Variable (Time/Div)	Calibrated
5X Mag	Off
Stability	Adjusted as per instruction manual procedure
Source	Internal
Coupling	AC slow
Slope	+
Level	Free run

4. Connect the calibration oscilloscope directly to a power supply of appropriate voltage.

5. Set the calibration oscilloscope power switch to on. Allow at least 20 minutes warm up at 25°C, ±5°C, for checking the instrument to the given accuracy.

### 1. Adjust Channel 1 Step Attenuator Balance

REQUIREMENT—No trace shift as the VOLTS/DIV switch is rotated from the 10 mV position to the 0.1 V position.

- a. Rotate the channel 1 VOLTS/DIV switch back and forth between 10 mV and 0.1 mV.
- b. CHECK—Trace shift; must be no trace shift as part a of this step is performed.
- c. ADJUST—STEP ATTEN BALANCE control, R235, (Fig. 5-1) for no trace shift as part a of this step is performed.

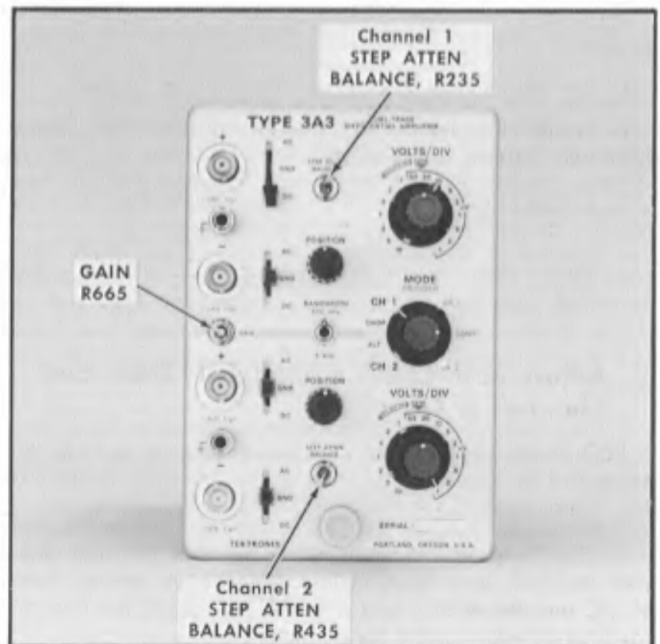


Fig. 5-1. Location of Channel 1 STEP ATTEN BALANCE control R235, Channel 2 STEP ATTEN BALANCE control R435, and GAIN control R665.

## 2. Check Channel 1 Variable DC Balance

Step 1 must be performed before proceeding with this step.

REQUIREMENT—Allowable trace shift is 1 minor division or less.

- a. Set the channel 1 VOLTS/DIV switch to 10 mV.
- b. Rotate the channel 1 VARIABLE (VOLTS/DIV) control from one extreme to the other.
- c. CHECK—Trace shift; must be no more than 1 minor division as part b of this step is performed.
- d. Return the channel 1 VARIABLE (VOLTS/DIV) control to its CAL position.

## 3. Adjust Channel 2 Step Attenuator Balance

REQUIREMENT—No trace shift as the VOLTS/DIV switch is rotated from 10 mV to 0.1 mV.

- a. Set the Type 3A3 mode switch to CH 2.
- b. Rotate the channel 2 VOLTS/DIV switch back and forth between 10 mV and 0.1 mV.
- c. CHECK—Trace shift; must be no trace shift as part b of this step is performed.
- d. ADJUST—STEP ATTEN BALANCE control, R435, (Fig. 6-5) for no trace shift as part b of this step is performed.

## 4. Check Channel 2 Variable DC Balance

Step 3 must be performed before proceeding with this step.

REQUIREMENT—Allowable trace shift is 1 minor division or less.

- a. Set the channel 2 VOLTS/DIV switch to 10 mV.
- b. Rotate the channel 2 VARIABLE (VOLTS/DIV) control from one extreme to the other.
- c. CHECK—Trace shift; must be no more than 1 minor division as part b of this step is performed.
- d. Return the channel 2 VARIABLE (VOLTS/DIV) control to its CAL position.

## 5. Adjust and Check Channel 1 Gain and Channel 2 Gain

REQUIREMENT—Gain of both input channels must be the same and be adjustable to the correct deflection factor with the GAIN control.

- a. Set the Type 3A3, VOLTS/DIV switches for both channels to 1 mV, + Input Coupling switches for both channels to DC and the MODE switch to ALT. Also, set the horizontal plug-in level control to automatic.
- b. Connect one end of a dual-input coupler to the channel 1 + input connector and the other end to the channel 2 + input connector.

- c. Connect a 5 mV, 1 kHz square-wave signal from a standard amplitude calibrator via a 50 ohm coaxial cable to the center connector of a dual-input coupler.

- d. With the channel 1 POSITION control, position the channel 1 display to a convenient position on the graticule so the display amplitude can be measured.

- e. CHECK—Channel 1 display amplitude; should be exactly 5 major divisions.

- f. ADJUST—GAIN control, R665, (Fig. 5-1) until a channel 1 display amplitude of exactly 5 major divisions is obtained.

- g. With the channel 2 POSITION control, position the channel 2 display to a convenient position on the graticule so the display amplitude can be measured.

- h. CHECK—Channel 2 display amplitude; should be exactly 5 major divisions.

### NOTE

If the channel 2 display amplitude is not exactly 5 major divisions, either channel 1 or 2 gain control or both will have to be adjusted. See either the Operation Instructions or the Calibration procedure section of this manual.

- i. The test equipment remains connected for step 6.

## 6. Check Channel 1 Variable (VOLTS/DIV) Control

REQUIREMENT—VARIABLE (VOLTS/DIV) control must attenuate the input signal by a 2.5:1 ratio when it is fully counterclockwise. The control must change the signal smoothly in size as it is rotated.

- a. Set the MODE switch to CH 1.

- b. Rotate the channel 1 VARIABLE (VOLTS/DIV) control from its CAL position slowly counterclockwise to its fully counterclockwise position.

- c. CHECK—Display behavior and final amplitude; the display should have slowly decreased in amplitude, without any jitter, to a display amplitude of 2 major divisions or less.

- d. Return the channel 1 VARIABLE (VOLTS/DIV) control to its CAL position.

- e. The test equipment remains connected for step 7.

## 7. Check Channel 2 Variable (VOLTS/DIV) Control

REQUIREMENT—VARIABLE (VOLTS/DIV) control must attenuate the input signal by a 2.5:1 ratio when it is fully counterclockwise. The control must change the signal smoothly in size as it is rotated.

- a. Set the MODE switch to CH 2.

- b. Rotate the channel 2 VARIABLE (VOLTS/DIV) control from its CAL position slowly counterclockwise to its fully counterclockwise position.



## Performance Check—Type 3A3

c. CHECK—Display behavior and final amplitude; the display should have slowly decreased in amplitude, without any jitter, to a display amplitude of 2 major divisions or less.

d. Return the channel 2 VARIABLE (VOLTS/DIV) control to its CAL position.

e. Disconnect the standard amplitude calibrator, dual-input coupler and the 50 ohm coaxial cable.

## 8. Check Channel 2 Noise and Microphonics

REQUIREMENT—Noise:  $15\ \mu\text{V}$  or less of displayed noise. Microphonics: 1 major division or less of peak-to-peak microphonics.

a. Set the channel 2 VOLTS/DIV switch to 0.1 mV.

b. Set the level control for the horizontal plug-in to free run.

c. Connect a 10 kHz, square-wave signal from a square-wave generator via a GR to BNC female adapter, a 5X BNC attenuator, three 10X BNC attenuators, 50 ohm coaxial cable and a 50 ohm BNC termination to the Type 3A3 channel 2 + input connector.

### NOTE

The third-wire power cord ground must be disconnected from the square-wave generator for this check. Either use a 3-to-2 wire adapter on the power cord, or invert the female end of the power cord at the square-wave generator end. This procedure may cause the case of the square-wave generator to appear at a voltage above ground and thus constitute some shock hazard.

d. Decrease the output signal amplitude of the square-wave generator to the point where the two separate traces just merge into one trace (with no perceptible dark separation) on the CRT of the calibration oscilloscope.

e. Remove one of the 10X BNC attenuators from the signal path.

f. CHECK—Calibration oscilloscope display amplitude; 1.5 major divisions or less. To obtain an actual voltage figure, measure the display amplitude in microvolts and divide this figure by 10.

g. Disconnect the square-wave generator, GR to BNC female adapter, 5X BNC attenuator, two 10X BNC attenuators, 50 ohm coaxial cable and a 50 ohm BNC termination.

h. Set the Type 3A3 channel 2 + Input Coupling switch to GND.

i. Set the time/div switch of the horizontal plug-in to 10 ms.

j. Tap lightly on the top of the Type 3A3 front-panel.

k. CHECK—Amount of microphonics; peak to peak microphonics display amplitude must be 1 major divisions or less.

## 9. Check Channel 1 Noise and Microphonics

REQUIREMENT—Noise:  $15\ \mu\text{V}$  or less of displayed noise. Microphonics: 1 major division or less of peak-to-peak microphonics.

a. Set the MODE switch to CH 1.

b. Set the channel 1 VOLTS/DIV switch to 0.1 mV.

c. Set the time/div switch for the horizontal plug-in to 0.5 ms.

d. Connect a 10 kHz, square-wave signal from a square-wave generator via a GR to BNC female adapter, a 5X BNC attenuator, three 10X BNC attenuators, 50 ohm coaxial cable and a 50 ohm BNC termination to the Type 3A3 channel 1 + input connector. This step requires that the square-wave generator power cord be ungrounded. See NOTE in Step 8.

e. Decrease the output signal amplitude of the square-wave generator to the point where the two separate traces just merge into one trace (with no perceptible dark separation) on the CRT of the calibration oscilloscope.

f. Remove one of the 10X BNC attenuators from the signal path.

g. CHECK—Calibration oscilloscope display amplitude; 1.5 major divisions or less. To obtain an actual voltage figure, measure the display amplitude in microvolts and divide this figure by 10.

h. Disconnect the square-wave generator, GR to BNC female adapter, 5X BNC attenuator, two 10X BNC attenuators, 50 ohm coaxial cable and a 50 ohm BNC termination.

i. Set the Type 3A3 channel 1 + Input Coupling switch to GND.

j. Set the time/div switch of the horizontal plug-in to 10 ms.

k. Tap lightly on the top of the Type 3A3 front-panel.

l. CHECK—Amount of microphonics; peak to peak microphonics display amplitude must be 1 major division or less.

## 10. Check Channel 1 + Input Current Zero and — Input Current Zero

REQUIREMENT—100 picoamperes, maximum. 100 picoamperes through the 1 megohm grid return circuit will cause 1 major division of trace shift at 0.1 mV/div.

a. Set the Type 3A3 TRIGGER switch to CH 1 and the BANDWIDTH switch to 5 kHz.

b. Set the time/div switch of the horizontal plug-in to 0.5 ms.

c. Position the trace to the center horizontal line of the graticule with the channel 1 POSITION control.

d. Connect a 50 ohm BNC termination to the channel 1 + input connector.

e. Change the channel 1 + Input coupling switch back and forth from GND to AC.

f. CHECK—Trace movement; should not shift more than 1 major division (one major division corresponds to 100 picoamperes) as part e of this step is being accomplished. Ignore any transient movements when measuring the amount of trace position change.

g. Set the channel 1 + Input Coupling switch to GND.



h. Remove the 50 ohm BNC termination from the channel 1 + input connector.

i. Position the trace to the center horizontal line of the graticule with the channel 1 POSITION control.

j. Connect a 50 ohm BNC termination to the channel 1 — input connector.

k. Change the channel 1 — Input Coupling switch back and forth from GND to AC.

l. CHECK—Trace movement; should not shift more than 1 major division (one major division corresponds to 100 picoamperes) as part k of this step is being accomplished. Ignore any transient movements when measuring the amount of trace position change.

m. Set the channel 1 — Input Coupling switch to GND.

n. Remove the 50 ohm BNC termination from the channel 1 — input connector.

## 11. Check Channel 2 + Input Current Zero and — Input Current Zero

REQUIREMENT—100 picoamperes maximum. 100 picoamperes through the 1 megohm grid return circuit will cause 1 major division of trace shift at 0.1 mV/div.

a. Set the MODE switch to CH 2 and the TRIGGER switch to CH 2.

b. Position the trace to the center horizontal line of the graticule with the channel 2 POSITION control.

c. Connect a 50 ohm BNC termination to the channel 2 + input connector.

d. Change the channel 2 + Input Coupling switch back and forth from its GND position to its AC position.

e. CHECK—Trace movement; should not shift more than 1 major division (one major division corresponds to 100 picoamperes) as part d of this step is being accomplished. Ignore any transient movements when measuring the amount of trace position change.

f. Set the channel 2 + Input Coupling switch to GND.

g. Remove the 50 ohm BNC termination from the channel 2 + input connector.

h. Position the trace to the center horizontal line of the graticule with the channel 2 POSITION control.

i. Connect a 50 ohm BNC termination to the channel 2 — input connector.

j. Change the channel 2 — Input Coupling switch back and forth from GND to AC.

k. CHECK—Trace movement; should not shift more than 1 major division (one major division corresponds to 100 picoamperes) as part j of this step is being accomplished. Ignore any transient movements when measuring the amount of trace position change.

l. Set the channel 2 — Input Coupling switch to GND.

m. Remove the 50 ohm BNC termination from the channel 2 — input connector.

## 12. Check Channel 1 Volts/Division Accuracy

REQUIREMENT—The deflection factor of the oscilloscope display is within  $\pm 3\%$  of the VOLTS/DIV switch indication.

a. Set the Type 3A3 channel 1 — Input Coupling switch to DC, MODE switch to CH 1, TRIGGER switch to COMP and the BANDWIDTH switch to 500 kHz. Also set the horizontal plug-in level control to free run.

b. Connect a 0.5 mV, 1 kHz square-wave signal from a standard amplitude calibrator via a 50 ohm coaxial cable to the channel 1 — input connector.

c. Set the standard amplitude calibrator output square-wave signal to the appropriate amplitude as listed in Table 5-1.

d. Set the channel 1 VOLTS/DIV switch to the appropriate position listed in Table 5-1.

e. CHECK—Amount of deflection; see Table 5-1 for correct amount of DC deflection and tolerance (ignore any overshoot or rounding).

f. Repeat parts c through e of this step until the table has been completed.

TABLE 5-1

VOLTS/DIV Accuracy Check

Square-Wave Signal Amplitude Peak to Peak	Type 3A3 VOLTS/DIV Switch	Deflection Amount and Tolerance in Major Divisions
0.5 mV	0.1 mV	5, $\pm 0.15$
1 mV	0.2 mV	5, $\pm 0.15$
2 mV	0.5 mV	4, $\pm 0.12$
5 mV	1 mV	5, $\pm 0.15$
10 mV	2 mV	5, $\pm 0.15$
20 mV	5 mV	4, $\pm 0.12$
50 mV	10 mV	5, $\pm 0.15$
0.1 V	20 mV	5, $\pm 0.15$
0.2 V	50 mV	4, $\pm 0.12$
0.5 V	0.1 V	5, $\pm 0.15$
1 V	0.2 V	5, $\pm 0.15$
2 V	0.5 V	4, $\pm 0.12$
5 V	1 V	5, $\pm 0.15$
10 V	2 V	5, $\pm 0.15$
20 V	5 V	4, $\pm 0.12$
50 V	10 V	5, $\pm 0.15$

g. The test equipment remains connected for step 13.

## 13. Check Channel 2 Volts/Division Accuracy

REQUIREMENT—The deflection factor of the oscilloscope display is within  $\pm 3\%$  of the VOLTS/DIV switch indication.

a. Set the channel 1 — Input Coupling switch to GND, the channel 2 — Input Coupling switch to DC and the MODE switch to CH 2.

### Performance Check—Type 3A3

b. Disconnect the 50 ohm coaxial cable from the channel 1 — input connector and connect it to the channel 2 — input connector.

c. Set the standard amplitude calibrator output square-wave signal amplitude control for a signal amplitude of 0.5 mV peak to peak, the starting signal amplitude in Table 5-1.

d. Set the standard amplitude calibrator output square-wave signal to the appropriate amplitude as listed in Table 5-1.

e. Set the channel 2 VOLTS/DIV switch to the appropriate position listed in Table 5-1.

f. CHECK—Amount of deflection; see Table 5-1 for correct amount of DC deflection and tolerance.

g. Repeat parts d through f of the step until the table has been completed.

h. Disconnect the standard amplitude calibrator and the 50 ohm coaxial cable.

### 14. Check Channel 1 Low Frequency Common Mode Rejection Ratio

REQUIREMENT—Common mode rejection ratio of at least 50,000:1 when a 100 Hz, 10 volt peak-to-peak common-mode sine-wave signal is DC coupled to the Type 3A3.

a. Change the following controls:

Type 3A3	
VOLTS/DIV (both channels)	2 V
+ Input Coupling (channel 1)	DC
— Input Coupling (both channels)	GND
MODE	CH 1

#### 2B- or 3B-Series Plug-In

Time/Div	1 ms
Level	Automatic

b. Connect one end of a dual-input coupler to the channel 1 + input connector and the other end of the coupler to the channel 1 — input connector.

c. Connect a 10 V, 100 Hz sine-wave signal from a low frequency sine-wave generator via a BNC female to dual banana plug adapter and a 50 ohm coaxial cable to the center connector of the dual-input coupler.

d. After setting the output signal amplitude of the low frequency sine-wave generator to 10 V, set the Type 3A3 channel 1 VOLTS/DIV switch to 0.1 mV and the channel 1 — Input Coupling switch to DC.

e. With the channel 1 POSITION control, position the channel 1 display to a convenient position on the graticule so the display amplitude can be measured.

f. CHECK—Channel 1 display amplitude; should not be more than 2 major divisions.

g. The test equipment remains connected for step 15.

### 15. Check Channel 2 Low Frequency Common Mode Rejection Ratio

REQUIREMENT—Common mode rejection ratio of at least 50,000:1 when a 100 Hz, 10 volt peak-to-peak common-mode sine-wave signal is DC coupled to the Type 3A3.

a. Set the channel 2 + Input Coupling switch to DC and the MODE switch to CH 2.

b. Disconnect the dual-input coupler from the channel 1 input connectors and connect it to the channel 2 input connectors.

c. With the output of the low frequency sine-wave generator still connected to the dual-input coupler, set the output signal amplitude of the low frequency sine-wave generator to 10 V. Set the Type 3A3 channel 2 VOLTS/DIV switch to 0.1 mV and the channel 2 — Input Coupling switch to DC.

d. With the channel 2 POSITION control, position the channel 2 display to a convenient position on the graticule so the display amplitude can be measured.

e. CHECK—Channel 2 display amplitude; should not be more than 2 major divisions.

f. The test equipment remains connected for step 16.

### 16. Check Channel 2 Attenuator Differential Balance Controls

REQUIREMENT—Refer to Table 5-2.

a. Set the channel 2 VOLTS/DIV switch to 5 V and the channel 2 — Input Coupling switch to GND.

b. With the output of the low frequency sine-wave generator still connected to the dual-input coupler, set the output signal amplitude of the low frequency sine-wave generator to 20 V, (output frequency still 100 Hz) then set the Type 3A3 channel 2 VOLTS/DIV switch to the first position listed in Table 5-2. Set the channel 2 — Input Coupling switch to DC.

c. With the channel 2 POSITION control, position the channel 2 display to a graticule location convenient for measuring display amplitude.

d. CHECK—Channel 2 display amplitude; see Table 5-2.

e. Set the Type 3A3 channel 2 VOLTS/DIV switch to the next position listed in Table 5-2.

f. Repeat parts c through e of this step until Table 5-2 is completed for channel 2.

g. The test equipment remains connected for step 17.

### 17. Check Channel 1 Attenuator Differential Balance Controls

REQUIREMENT—Refer to Table 5-2.

a. Set the channel 1 VOLTS/DIV switch to 5 V, the channel 1 — Input Coupling switch to GND and the MODE switch to CH 1.

**TABLE 5-2**

Attenuator Differential Balance Check

VOLTS/DIV Switch Setting for Channel being Checked	Maximum Allowable Display Amplitude in Major Divisions	Common Mode Rejection Ratio
20 mV	0.2	5000:1
0.2 V	0.2	500:1
2 V	0.02	500:1

b. Disconnect the dual-input coupler from the channel 2 input connectors and connect it to the channel 1 input connectors.

c. With the output of the low frequency sine-wave generator still connected to the dual-input coupler, set the output signal amplitude of the low frequency sine-wave generator to 20 V (output frequency still 100 Hz). Set the Type 3A3 channel 1 VOLTS/DIV switch to the position to be checked as listed in Table 5-2. Set the channel 1 — Input Coupler switch to DC.

d. With the channel 1 POSITION control, position the channel 1 display to a convenient location on the graticule to measure display amplitude.

e. CHECK—Channel 1 display amplitude; see Table 5-2.

f. Set the Type 3A3 channel 1 VOLTS/DIV switch to the next position listed in Table 5-2.

g. Repeat parts d through f of this step until Table 5-2 is completed for channel 1.

h. Disconnect the low frequency sine-wave generator, BNC female to banana plug adapter, 50 ohm coaxial cable and the dual-input coupler.

**18. Check Channel 1 Cross-Neutralization**

REQUIREMENT—When switching the opposite input switch from GND to DC there should be no more than 0.5 minor divisions of rolloff, overshoot or peak-to-peak aberrations.

a. Change the following controls:

Type 3A3	
VOLTS/DIV (both channels)	10 mV
+ Input Coupling (channel 2)	GND
— Input Coupling (both channels)	GND
2B- or 3B-Series Plug-In	
Time/Div	0.5 ms
Level	Adjusted for stable display

b. Connect a 1 kHz, fast rise square-wave signal having a positive-going transition from a square-wave generator via a 5 ns coaxial cable, a GR to BNC male adapter and

a 5X BNC attenuator to the Type 3A3 channel 1 + input connector.

c. Adjust the square-wave generator so a 50 mV square-wave signal is applied to the channel 1 + input connector.

d. Change the channel 1 — Input Coupling switch back and forth from GND to DC.

e. CHECK—Displayed waveforms; there should be 0.5 minor division or less of rolloff, overshoot or peak-to-peak aberrations as part d of this step is accomplished.

f. Disconnect the input square-wave signal from the channel 1 + input connector and connect it to the channel 1 — input connector.

g. Set the channel 1 + Input Coupling switch to GND and the channel 1 — Input Coupling switch to DC.

h. Change the channel 1 + Input Coupling switch back and forth from GND to DC.

i. CHECK—Displayed waveform; there should be 0.5 minor divisions or less roll-off, overshoot or peak-to-peak aberrations as part h of this step is accomplished.

j. The test equipment remains connected for step 19.

**19. Check Channel 2 Cross-Neutralization**

REQUIREMENT—When switching the opposite input switch from GND to DC there should be no more than 0.5 minor division of roll-off, overshoot or peak-to-peak aberrations.

a. Set the channel 2 + Input Coupling switch to DC and the MODE switch to CH 2.

b. Disconnect the input square-wave signal from the channel 1 — input connector and connect to the channel 2 + input connector.

c. Adjust the input square-wave signal for a 50 mV signal amplitude at the channel 2 + input connector.

d. Change the channel 2 — Input Coupling switch back and forth from GND to DC.

e. CHECK—Displayed waveforms; there should be 0.5 minor division or less of rolloff, overshoot or peak-to-peak aberrations as part d of this step is accomplished.

f. Disconnect the input square-wave signal from the channel + input connector and connect it to the channel 2 — input connector.

g. Set the channel 2 + Input Coupling switch to GND and the channel 2 — Input Coupling switch to DC.

h. Change the channel 2 + Input Coupling switch back and forth from GND to DC.

i. CHECK—Displayed waveform; there should be 0.5 minor division or less of rolloff, overshoot or peak-to-peak aberrations as part h of this step is accomplished.

j. Disconnect the square-wave generator, 5 ns coaxial cable, GR to BNC male adapter and 5X BNC attenuator.

## 20. Check Channel 1 Input Capacitance and Attenuator Compensation

REQUIREMENT—A 5 major division 1 kHz square-wave signal via a 47 pF input RC normalizer should not have more than 0.75 major division of rolloff, overshoot or tilt.

a. Set the Type 3A3 channel 1 + Input Coupling switch to DC, channel 2 + Input Coupling switch to GND, channels 1 and 2 — Input Coupling switches to GND and the MODE switch to CH 1.

b. Connect a 1 kHz, high amplitude square-wave signal from a square-wave generator via a 5 ns coaxial cable, a GR to BNC male adapter, a 10× BNC attenuator and a 47 pF input RC normalizer to the Type 3A3 channel 1 + input connector.

c. Adjust the output signal amplitude of the square-wave generator to obtain a display about 5 major divisions in amplitude.

d. CHECK—Displayed waveform; should appear similar to the waveform shown in Fig. 5-2A.

e. Set the Type 3A3 channel 1 VOLTS/DIV switch to the next position. Remove the 10× BNC attenuator where necessary to obtain enough display amplitude.

f. Repeat parts c through e of this step until a check of all VOLTS/DIV switch positions between 10 mV and 10 V has been completed for channel 1 + input connector.

g. Disconnect the input square-wave signal from the channel 1 + input connector and connect it to the channel 1 — input connector. Re-insert the 10× BNC attenuator between the GR to BNC male adapter and the 47 pF input RC normalizer.

h. Set the channel 1 VOLTS/DIV switch to 10 mV, channel 1 + Input Coupling switch to GND and the channel 1 — Input Coupling switch to DC.

i. Adjust the output signal amplitude of the square-wave generator to obtain a display about 5 major divisions in amplitude.

j. CHECK—Displayed waveform; should appear similar to the waveform shown in Fig. 5-2A.

k. Set the Type 3A3 channel 1 VOLTS/DIV switch to the next position. Remove the 10× BNC attenuator where necessary to obtain enough display amplitude.

l. Repeat parts i through k of this step until a check of all VOLTS/DIV switch positions between 10 mV and 10 V has been completed for channel 1 — input connector.

m. The test equipment remains connected for step 21.

## 21. Check Channel 2 Input Capacitance and Attenuator Compensation

REQUIREMENT—A 5 major division 1 kHz square-wave signal via a 47 pF input RC normalizer should not have more than 0.75 major division of rolloff, overshoot or tilt.

a. Set the channel 2 + Input Coupling to DC and the MODE switch to CH 2.

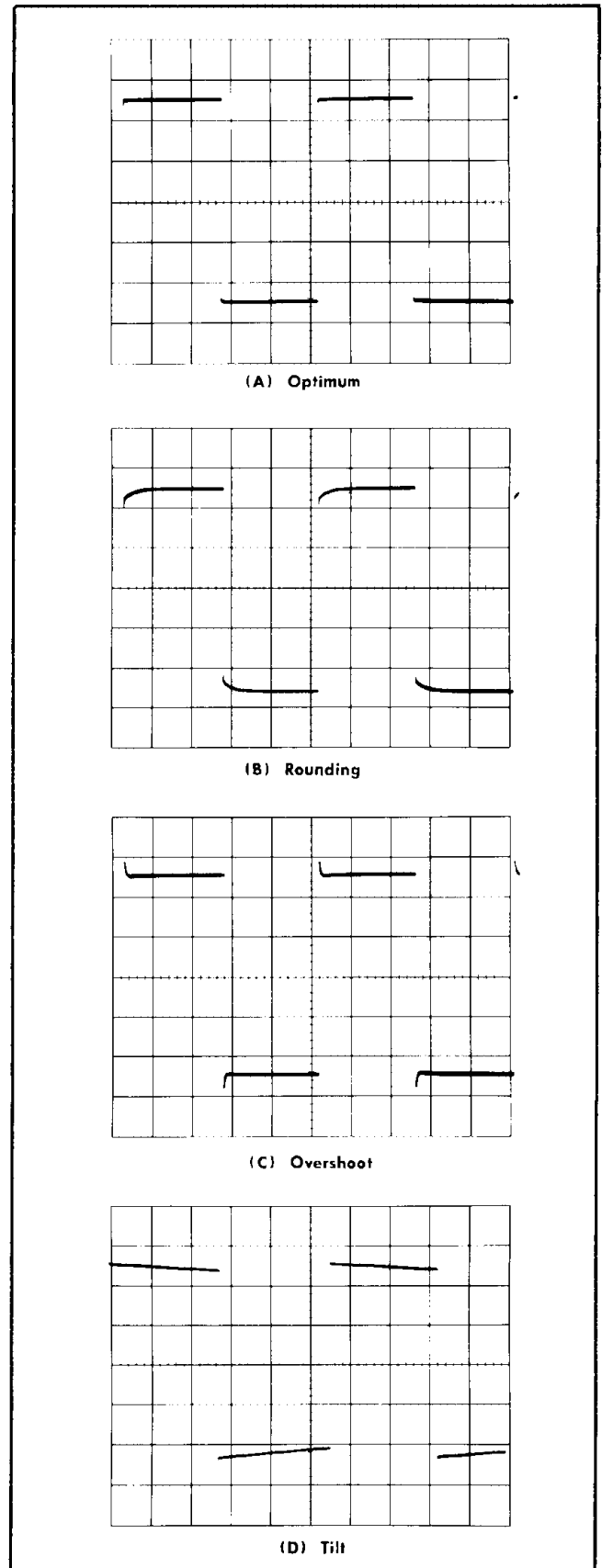


Fig. 5-2. Photographs of the waveform as it may appear when checking the input capacitance and attenuator compensation.

b. Disconnect the input square-wave signal from the channel 1 — input connector and connect it to the channel 2 + input connector. Re-insert the 10× BNC attenuator between the GR to BNC male adapter and the 47 pF input RC normalizer.

c. Adjust the output signal amplitude of the square-wave generator to obtain a display about 5 major divisions in amplitude.

d. CHECK—Displayed waveform; should appear similar to the waveform shown in Fig. 5-2A.

e. Set the Type 3A3 channel 2 VOLTS/DIV switch to the next position. Remove the 10× BNC attenuator where necessary to obtain enough display amplitude.

f. Repeat parts c through e of this step until a check of all VOLTS/DIV switch positions between 10 mV and 10 V has been completed for channel 2 + input connector.

g. Disconnect the input square-wave signal from the channel 2 + input connector and connect it to the channel 2 — input connector. Re-insert the 10× BNC attenuator between the GR to BNC male adapter and the 47 pF input RC normalizer.

h. Set the channel 2 VOLTS/DIV switch to 10 mV, channel 2 + Input Coupling switch to GND and the channel 2 — Input Coupling switch to DC.

i. Adjust the output signal amplitude of the square-wave generator to obtain a display about 5 major divisions in amplitude.

j. CHECK—Displayed waveform; should appear similar to the waveform shown in Fig. 5-2.

k. Set the Type 3A3 channel 2 VOLTS/DIV switch to the next position. Remove the 10× BNC attenuator where necessary to obtain enough display amplitude.

l. Repeat parts i through k of this step until a check of all VOLTS/DIV switch positions between 10 mV and 10 V has been completed for channel 2 — input connector.

m. Disconnect the square-wave generator, 5 ns coaxial cable GR to BNC male adapter and 47 pF input RC normalizer.

## 22. Check Channel 1 High Frequency Differential Balance Capacitors

REQUIREMENT—Common mode rejection ratio of at least 50,000:1 when a 100 kHz, 10 volt peak-to-peak common-mode sine-wave signal is DC coupled to the Type 3A3.

a. Set the Type 3A3 channels 1 and 2 VOLTS/DIV switches to 2 V, channel 1 + Input Coupling switch to DC, channels 1 and 2 — Input Coupling switches to GND and the MODE switch to CH 1. Also set the horizontal plug-in time/div switch to 1 ms and the level control to free run.

b. Connect one end of the dual-input coupler to the Type 3A3 channel 1 + input connector. Connect the other end of the dual-input coupler to the channel 1 — input connector.

c. Connect a 10 V, 100 kHz sine-wave signal from a low frequency sine-wave generator via a BNC female to dual banana plug adapter and a 50 ohm coaxial cable to the center connector of the dual-input coupler.

d. Adjust the sine-wave signal amplitude to obtain a display of 5 major divisions.

e. Set the channel 1 — Input Coupling switch to DC and the channel 1 VOLTS/DIV switch to 0.1 mV.

f. Use the channel 1 POSITION control to move the display to a convenient measuring point on the graticule.

g. CHECK—Display amplitude; should be 2 major divisions or less.

h. The test equipment remains connected for step 23.

## 23. Check Channel 2 High Frequency Differential Balance Capacitors

REQUIREMENT—Common mode rejection ratio of at least 50,000:1 when a 100 kHz, 10 volt peak-to-peak common-mode sine-wave signal is DC coupled to the Type 3A3.

a. Set the channel 2 + Input Coupling switch to DC and the MODE switch to CH 2.

b. Disconnect the dual-input coupler from channel 1 input connectors and connect it to the channel 2 input connectors.

c. Adjust the sine-wave signal amplitude to obtain a display of 5 major divisions.

d. Set the channel 2 — Input Coupling switch to DC and the channel 2 VOLTS/DIV switch to 0.1 mV.

e. Use the channel 2 POSITION control to move the display to a convenient measuring point on the graticule.

f. CHECK—Display amplitude; should be 2 major divisions or less.

g. The test equipment remains connected for step 24.

## 24. Check Channel 2 — Input Attenuator Compensation Capacitors

REQUIREMENT—Refer to Table 5-3

a. Set the channel 2 VOLTS/DIV switch to 2 V and channel 2 — Input Coupling switch to GND.

b. Adjust the sine-wave signal amplitude to obtain a display of 5 major divisions.

c. Set the channel 2 — Input Coupling switch to DC and the channel 2 VOLTS/DIV switch to the setting called out in Table 5-3 for the adjustment being checked.

d. Use the channel 2 POSITION control to move the display to a convenient measuring point on the graticule.

e. CHECK—Display amplitude; should be equal to or less than the display amplitude called out in Table 5-3 for the VOLTS/DIV switch position being checked.

f. Repeat parts c through e of the step until Table 5-3 is completed for channel 2.

g. The test equipment remains connected for step 25.

**Performance Check—Type 3A3**

**TABLE 5-3**

— Input Attenuator Compensation Check

VOLTS/DIV Switch Setting for Channel being checked	Maximum Display Amplitude in Minor Divisions	Common Mode Rejection Ratio
20 mV	5	1000:1
0.2 V	1	500:1
2 V	Normal Trace Width	500:1

**25. Check Channel 1 — Input Attenuator Compensation Capacitors**

REQUIREMENT—Refer to Table 5-3

- a. Set the channel 1 VOLTS/DIV switch to 2 V, channel 1 — Input Coupling switch to GND and the MODE switch to CH 1.
- b. Disconnect the dual-input coupler from channel 2 input connectors and connect it to the channel 1 input connectors.
- c. Adjust the sine-wave signal amplitude to obtain a display of 5 major divisions.
- d. Set the channel 1 — Input Coupling switch to DC and the channel 1 VOLTS/DIV switch to the setting called out in Table 5-3 for the adjustment being checked.
- e. Use the channel 1 POSITION control to move the display to a convenient measuring point on the graticule.
- f. CHECK—Display amplitude; should be equal to or less than the display amplitude called out in Table 5-3 for the VOLTS/DIV switch position being checked.
- g. Repeat parts d through f of this step until Table 5-3 is completed for channel 1.
- h. Disconnect the low frequency sine-wave generator, BNC female to dual banana plug adapter, 50 ohm coaxial cable and the dual-input coupler.

**26. Check Channel 1 High Frequency Compensation Capacitors**

REQUIREMENT—Lower right-hand corner of 8 major division wide display should be an optimum square corner having 0.75 minor division or less of rounding or overshoot.

**NOTE**

This step cannot be performed if a Type 565 or RM565 Oscilloscope is being used as the calibration oscilloscope.

- a. Change the following controls:

**Type 3A3**

VOLTS/DIV (both channels)	10 mV
+ Input Coupling (channel 2)	GND

—Input Coupling (both channels)

GND

**2B- or 3-B Series Plug-In**

Time/Div Level	5 $\mu$ s Automatic
----------------	------------------------

b. Remove the Type 3A3 from the vertical plug-in compartment, and the 2B- or 3B-series plug-in from the horizontal plug-in compartment of the calibration oscilloscope.

c. Install the Type 3A3 into the horizontal plug-in compartment of the calibration oscilloscope without the plug-in extension, then install the 2B- or 3B-series plug-in into the vertical plug-in compartment.

d. Connect an 80 mV, 100 kHz square-wave signal from a square-wave generator via a 5 ns coaxial cable, a 50 ohm GR to BNC termination and a 10 $\times$  BNC attenuator to the Type 3A3 channel 1 + input connector.

e. Adjust the square-wave signal amplitude to obtain a display of 8 major divisions.

f. Use the channel 1 POSITION control and the 2B- or 3B-series plug-in position control to position the display to a convenient place on the graticule.

g. CHECK—Lower right-hand corner of the display; should be an optimum square corner having 0.75 minor division or less of rounding or overshoot.

h. Set the channel 1 VOLTS/DIV switch to the next position listed in Table 5-4.

i. Repeat parts e through h of this step until Table 5-4 has been completed for channel 1.

j. The test equipment remains connected for step 27.

**27. Check Channel 2 High Frequency Compensation Capacitors**

REQUIREMENT—Lower right-hand corner of 8 major division wide display should be an optimum square corner having 0.75 minor division or less of rounding or overshoot.

**NOTE**

This step cannot be performed if a Type 565 or RM565 Oscilloscope is being used as the calibration oscilloscope.

a. Set the channel 2 + Input Coupling switch to DC and the MODE switch to CH 2.

b. Disconnect the square-wave signal from the channel 1 + input connector and connect it to the channel 2 + input connector.

c. Remove all but one of the 10 $\times$  BNC attenuators from between the 50 ohm GR to BNC termination and the channel 2 + input connector.

d. Adjust the square-wave signal amplitude to obtain a display of 8 major divisions.

TABLE 5-4

## High Frequency Compensation of Capacitor Checks

VOLTS/DIV Switch Setting for Channel being checked	Amount of Attenuation to be Connected Between 50 ohm GR to BNC Termination and Type 3A3 Channel + Input Connector.
10 mV	10 times (1-10× attenuator)
5 mV	20 times (1-10× and 1-2× attenuators)
2 mV	50 times (1-10× and 1-5× attenuators)
1 mV	100 times (2-10× attenuators)
0.5 mV	200 times (2-10× and 1-2× attenuators)
0.2 mV	500 times (2-10× and 1-5× attenuators)
0.1 mV	1000 times (3-10× attenuators)

e. Use the channel 2 POSITION control and the 2B- or 3B-series plug-in position control to move the display to a convenient place on the graticule.

f. CHECK—Lower right-hand corner of the display; should be an optimum square corner having 0.75 minor division or less of rounding or overshoot.

g. Set the channel 2 VOLTS/DIV switch to the next position listed in Table 5-4.

h. Repeat parts d through g of this step until Table 5-4 has been completed for channel 2.

i. Disconnect the square-wave generator, 5 ns coaxial cable, 50 ohm GR to BNC termination and the three 10× BNC terminations.

## 28. Check Channel 1 Upper 500 kHz Bandwidth Frequency Response

REQUIREMENT—3 dB down at a frequency of 500 kHz or higher.

a. Set the Type 3A3 channel 2 + Input Coupling switch to GND and the MODE switch to CH 1. Also set the 2B- or 3B-series plug-in time/div switch to 0.5 ms and the level control to free run.

b. Remove the Type 3A3 from the horizontal plug-in compartment of the calibration oscilloscope and the 2B- or 3B-series plug-in from the vertical plug-in compartment.

c. Install the Type 3A3 into the vertical plug-in compartment of the calibration oscilloscope, and the 2B- or 3B-series plug-in into the horizontal plug-in compartment.

d. Connect 1 kHz sine-wave signal about 4 major divisions high from a low frequency sine-wave generator via a BNC female to dual banana plug adapter, BNC T adapter, 50 ohm coaxial cable and two 10× BNC attenuators to the Type 3A3 channel 1 + input connector.

e. Connect a second 50 ohm coaxial cable from the low frequency sine-wave generator signal output connector to the vertical input connector of the test oscilloscope via a 5× BNC attenuator.

f. Set the test oscilloscope vertical deflection factor to give a display of about 1 or more major divisions, AC coupled at a sweep rate of 0.5 ms/division with internal triggering.

g. Adjust the sine-wave signal amplitude to obtain a Type 3A3 display of exactly 4 major divisions.

h. Note the exact test oscilloscope displayed amplitude.

i. Increase the frequency of the sine-wave generator until the display amplitude on the calibration oscilloscope falls to 2.8 major divisions. The sine-wave output signal amplitude should be adjusted as necessary to keep the display amplitude of the test oscilloscope constant at the amplitude noted in part h of this step.

j. CHECK—Sine-wave frequency; 500 kHz or higher.

k. Repeat parts d through j of this step for each switch position of the channel 1 VOLTS/DIV switch for which sufficient input signal amplitude is available, removing the attenuators as needed to obtain the 4 major division display as described in part g of this step. The test oscilloscope volts/division switch will require changing as the sine-wave signal amplitude is increased.

l. The test equipment remains connected for step 29.

## 29. Check Channel 2 Upper 500 kHz Bandwidth Frequency Response

REQUIREMENT—3 dB down at a frequency of 500 kHz or higher.

a. Set the channel 1 + Input Coupling switch to GND, channel 2 + Input Coupling switch to DC and the MODE switch to CH 2.

b. Remove the sine-wave signal from channel 1 + input connector and connect a 1 kHz sine-wave signal about 4 major divisions high from a sine-wave generator via a BNC female to dual banana plug adapter, BNC T adapter, 50 ohm coaxial cable and two 10× BNC attenuators to the Type 3A3 channel 2 + input connector.

c. Connect a second 50 ohm coaxial cable from the low frequency sine-wave generator signal output connector to the vertical input connector of the test oscilloscope via a 5× BNC attenuator.

d. Set the test oscilloscope vertical deflection factor to give a display of about 1 or more major divisions, AC coupled at a sweep rate of 0.5 ms/division with internal triggering.

e. Adjust the sine-wave signal amplitude to obtain a Type 3A3 display of exactly 4 major divisions.

f. Note the exact test oscilloscope displayed amplitude.

g. Increase the frequency of the sine-wave generator until the display amplitude on the calibration oscilloscope falls to 2.8 major divisions. The sine-wave output signal amplitude should be adjusted as necessary to keep the display amplitude of the test oscilloscope constant at the amplitude noted in part f of this step.

h. CHECK—Sine-wave frequency; 500 kHz or higher.

i. Repeat parts b through h of this step for each switch position of the channel 2 VOLTS/DIV switch for which sufficient input signal amplitude is available, removing the attenuators as needed to obtain the 4 major division high dis-

## Performance Check—Type 3A3

play described in part e of this step. Adjust the test oscilloscope volts/division switch as the sine-wave signal amplitude is increased.

- j. The test equipment remains connected for step 30.

### 30. Check Channel 2 Upper 5 kHz Bandwidth Frequency Response

REQUIREMENT—3 dB down at a frequency of 5 kHz to 6.25 kHz.

- a. Set the Type 3A3 VOLTS/DIV switches of both channels to 10 mV and the BANDWIDTH switch to 5 kHz.
- b. Connect 1 kHz sine-wave signal about 4 major divisions high from a low frequency sine-wave generator via a BNC female to dual banana plug adapter, BNC T adapter and a 50 ohm coaxial cable to the Type 3A3 channel 2 + input connector.
- c. Connect a second 50 ohm coaxial cable from the low frequency sine-wave generator signal output connector to the vertical input connector of the test oscilloscope via a 5× BNC attenuator.
- d. Set the test oscilloscope vertical deflection factor to give a display of about 1 or more major divisions, AC coupled at a sweep rate of 0.5 ms/division with internal triggering.
- e. Adjust the sine-wave signal amplitude to obtain a Type 3A3 display of exactly 4 major divisions.
- f. Note the exact test oscilloscope displayed amplitude.
- g. Increase the frequency of the sine-wave generator until the display amplitude on the calibration oscilloscope falls to 2.8 major divisions. The sine-wave output signal amplitude should be adjusted as necessary to keep the display amplitude of the test oscilloscope constant at the amplitude noted in part f of this step.
- h. CHECK—Sine-wave frequency; 5 kHz to 6.25 kHz.
- i. The test equipment remains connected for step 31.

### 31. Check Channel 1 Upper 5 kHz Bandwidth Frequency Response

REQUIREMENT—3 dB down at a frequency of 5 kHz to 6.25 kHz.

- a. Set the channel 2 + Input Coupling switch to GND, channel 1 + Input Coupling switch to DC and the MODE switch to CH 1.
- b. Remove the sine-wave signal from channel 2 + input connector and connect a 1 kHz sine-wave signal about 4 major divisions high from a sine-wave generator via a BNC female to dual banana adapter, BNC T adapter and 50 ohm coaxial cable to the Type 3A3 channel 1 + input connector.
- c. Connect a second 50 ohm coaxial cable from the low frequency sine-wave generator signal output connector to the vertical input connector of the test oscilloscope via a 5× BNC attenuator.
- d. Set the test oscilloscope vertical deflection factor to give a display of about 1 or more major divisions, AC cou-

pled at a sweep rate of 0.5 ms/division with internal triggering.

- e. Adjust the sine-wave amplitude to obtain a Type 3A3 display of exactly 4 major divisions.
- f. Note the exact amplitude of the test oscilloscope display.
- g. Increase the frequency of the sine-wave generator until the display amplitude on the calibration oscilloscope falls to 2.8 major divisions. The sine-wave output signal amplitude should be adjusted as necessary to keep the display amplitude of the test oscilloscope constant at the amplitude noted in part f of this step.
- h. CHECK—Sine-wave frequency; 5 kHz to 6.25 kHz. Adjust the test oscilloscope volts/division switch as necessary as the sine-wave signal amplitude is increased.
- i. The test equipment remains connected for step 32.

### 32. Check Channel 1 AC Low Frequency Response

REQUIREMENT—3 dB down at a frequency of 2 Hz or lower.

- a. Set the channel 1 and 2 VOLTS/DIV switches to 10 mV, channel 1 + Input Coupling switch to AC and the BANDWIDTH switch to 500 kHz. Set the horizontal plug-in time/div switch to 1 ms.
- b. Disconnect the 50 ohm coaxial cable from the Type 3A3; connect a 10× BNC attenuator and a 5× BNC attenuator in the signal path, then reconnect the 50 ohm coaxial cable to the last attenuator in the Type 3A3 signal path.
- c. Connect 100 Hz sine-wave signal about 4 major divisions high from a sine-wave generator via BNC female to dual banana plug adapter, BNC T adapter, 50 ohm coaxial cable, a 10× BNC attenuator and a 5× BNC attenuator to the Type 3A3 channel 1 + input connector.
- d. Connect a second 50 ohm coaxial cable from the sine-wave generator signal output connector to the vertical input connector of the test oscilloscope via a 5× BNC attenuator.
- e. Set the test oscilloscope vertical deflection factor to give a display of about 1 or more major divisions, AC coupled at a sweep rate of 50 ms/division with internal triggering.
- f. Adjust the sine-wave signal amplitude to obtain a Type 3A3 display of exactly 4 major divisions.
- g. Note the exact amplitude of the test oscilloscope display.
- h. Decrease the frequency of the sine-wave generator until the display amplitude on the calibration oscilloscope falls to 2.8 major divisions. The sine-wave output signal amplitude should be adjusted as necessary to keep the display amplitude of the test oscilloscope constant at the amplitude noted in part g of this step.
- i. CHECK—Sine-wave frequency; 2 Hz or lower.
- j. Set the channel 1 + Input Coupling switch to GND and the channel 1 — Input Coupling switch to AC.



k. Connect 100 Hz sine-wave signal about 4 major divisions high from a sine-wave generator via a BNC female to dual banana plug adapter, BNC T adapter, 50 ohm coaxial cable, 10× BNC attenuator and a 5× BNC attenuator to the Type 3A3 channel 1 — input connector.

l. Repeat parts d through i of this step for the channel 1 — input connector.

m. The test equipment remains connected for step 33.

### 33. Check Channel 2 AC Low Frequency Response

REQUIREMENT—3 dB down at a frequency of 2 Hz or lower.

a. Set the channel 1 — Input Coupling switch to GND, channel 2 + Input Coupling switch to AC and the MODE switch to CH 2.

b. Remove the sine-wave signal from channel 1 — input connector and connect a 100 Hz sine-wave signal about 4 major divisions high from a sine-wave generator via a BNC female to dual banana plug adapter, BNC T adapter, 50 ohm coaxial cable, a 10× BNC attenuator and a 5× BNC attenuator to the Type 3A3 channel 2 + input connector.

c. Connect a second 50 ohm coaxial cable from the sine-wave generator signal output connector to the vertical input connector of the test oscilloscope via a 5× BNC attenuator.

d. Set the test oscilloscope vertical deflection factor to give a display of about 1 or more major divisions, AC coupled at a sweep rate of 50 ms/division with internal triggering.

e. Adjust the sine-wave signal amplitude to obtain a Type 3A3 display of exactly 4 major divisions.

f. Note the exact amplitude of the test oscilloscope display.

g. Decrease the frequency of the sine-wave generator until the display amplitude on the calibration oscilloscope falls to 2.8 major divisions. The sine-wave output signal amplitude should be adjusted as necessary to keep the display amplitude of the test oscilloscope constant at the amplitude noted in part g of this step.

h. CHECK—Sine-wave frequency; 2 Hz or lower.

i. Set the channel 2 + Input Coupling switch to GND and the channel 2 — Input Coupling switch to AC.

j. Connect 100 Hz sine-wave signal about 4 major divisions high from a sine-wave generator via a BNC female to dual banana plug adapter, BNC T adapter, 50 ohm coaxial cable, a 10× BNC attenuator and a 5× BNC attenuator to the Type 3A3 channel 2 — input connector.

k. Repeat parts d through i of this step for the channel 2 — input connector.

l. Disconnect the test oscilloscope, BNC female to dual banana plug adapter, BNC T adapter, sine-wave generator, the two 50 ohm coaxial cables, the 10× BNC attenuator and the two 5× BNC attenuators.

### 34. Check Alternate Mode of Operation

REQUIREMENT—Channel display alternation at all sweep rates.

a. Set the Type 3A3 channel 2 — Input Coupling switch to GND and the MODE switch to ALT.

b. Set the horizontal plug-in level control to free run.

c. Using the channel 1 and 2 POSITION controls, adjust the two traces so they are about 2 major divisions apart.

d. Rotate the horizontal plug-in time/div switch throughout its range.

e. CHECK—Calibration oscilloscope display; one channel then the other should be displayed alternately as part d of this step is performed.

### 35. Check Chopped Mode of Operation

REQUIREMENT—A chopped repetition rate of 200 kHz, ±25% and blanking of the vertical display transients.

a. Set the Type 3A3 MODE switch to CHOP.

b. Set the horizontal plug-in time/div switch to 1 μs and the level control to automatic.

c. Set the CRT cathode selector switch on the rear-panel of the calibration oscilloscope to ext CRT cathode position.

d. Using the channel 1 and 2 POSITION controls, obtain a display which will appear as a square-wave signal having an amplitude of 2 major divisions. It will be noted that the channel 1 POSITION control moves the top of the display and the channel 2 POSITION control moves the bottom of the display.

e. CHECK—Calibration oscilloscope display; one cycle of the square-wave display should occupy from 4 major divisions to 6.6 major divisions (4 μs to 6.6 μs) of sweep.

f. Set the CRT cathode selector switch on the rear-panel of the calibration oscilloscope to chopped blanking position.

g. CHECK—Calibration oscilloscope display; the vertical display transients should now be blanked out during the switching interval; see Fig. 5-3.

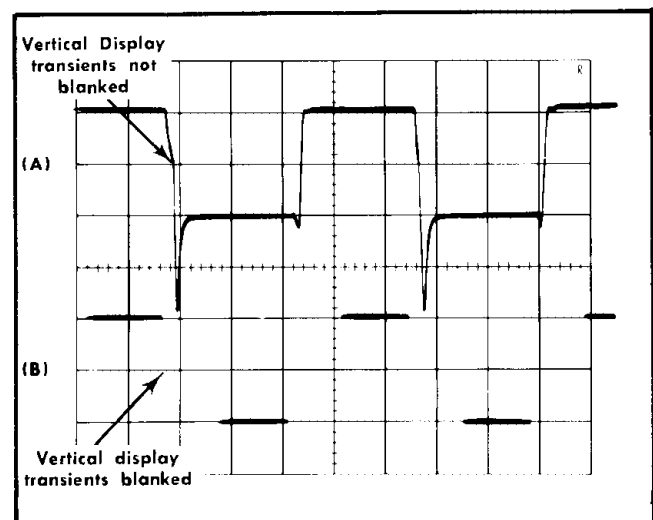


Fig. 5-3. Display presented when calibration oscilloscope CRT cathode selector switch set to: (A) Ext CRT cathode (B) Chopped blanking.

## Performance Check—Type 3A3

### 36. (Optional Step) Check Dual—Trace X-Y Operation

**REQUIREMENT**—One of the two dots that make up the display can be moved vertically by the left-hand channel 1 POSITION control and horizontally by the right-hand channel 1 POSITION control. The other dot can be moved similarly by the channel 2 POSITION controls.

#### NOTE

This step can be performed only if two calibrated Type 3A3 plug-ins are available and a 560-series calibration oscilloscope other than a Type 565 or RM565 is available.

- Remove the 2B- or 3B-series plug-in from the horizontal plug-in compartment of the calibration oscilloscope.
- Install a second calibrated Type 3A3 into the horizontal plug-in compartment of the calibration oscilloscope.
- Set the controls of both Type 3A3 plug-ins as follows:

VOLTS/DIV (both channels)	10 V
+ Input Coupling (both channels)	GND
— Input Coupling (both channels)	GND
MODE (vertical plug-in compartment)	CHOP
MODE (horizontal plug-in compartment)	ALT

- Set the CRT cathode selector switch on the rear-panel of the calibration oscilloscope to chopped blanking position.
- Rotate each POSITION control of each channel on each Type 3A3 plug-in throughout its range.
- CHECK—Calibration oscilloscope display; a display of only two spots should be able to be obtained and each POSITION control on the two plug-ins should affect only one spot as part e of this step is performed.

### 37. (Optional Step) Check Phase Shift Between Channels of Two Type 3A3 Plug-Ins in X-Y Configuration

**REQUIREMENT**—Less than  $2^\circ$  of phase shift between a channel of one Type 3A3 and a channel of a second Type 3A3.

#### NOTE

This step can be completed only with two calibrated Type 3A3 plug-ins and a 560-series calibration oscilloscope other than a Type 565 or RM565.

This check should be performed when two Type 3A3's are to be used in X-Y configuration for precise phase comparisons between two signals of the same frequency.

- With two Type 3A3's installed into the calibration oscilloscope, set the following controls of both Type 3A3 plug-ins as follows:

VOLTS/DIV (both channels)	0.1 V
POSITION (both channels)	Midrange
+ Input Coupling (both channels)	GND
— Input Coupling (both channels)	GND
MODE	CH 1

- Connect one end of a dual-input coupler to the vertical plug-in compartment Type 3A3 channel 1 + input connector, then connect the other end of the dual-input coupler to the horizontal plug-in compartment Type 3A3 channel 1 + input connector.
- Connect a 10 V, 100 kHz sine-wave signal from a sine-wave generator via a BNC female to dual banana plug adapter, a 50 ohm coaxial cable and  $10\times$  BNC attenuator to the center connector of the dual-input coupler.
- Set the vertical plug-in compartment Type 3A3 channel 1 + Input Coupling switch to DC.
- Adjust the sine wave signal amplitude to obtain a trace length of 8 major divisions.
- Set the vertical plug-in compartment Type 3A3 channel 1 + Input Coupling switch to GND.
- Set the horizontal plug-in compartment Type 3A3 channel 1 + Input Coupling switch to DC.
- Check for a trace length of 8 major divisions. If the trace length is not 8 major divisions, the gain of the two Type 3A3 plug-ins is not the same; refer to the Section 2 Operating Instructions or the Calibration procedure for the correct gain-setting procedure.

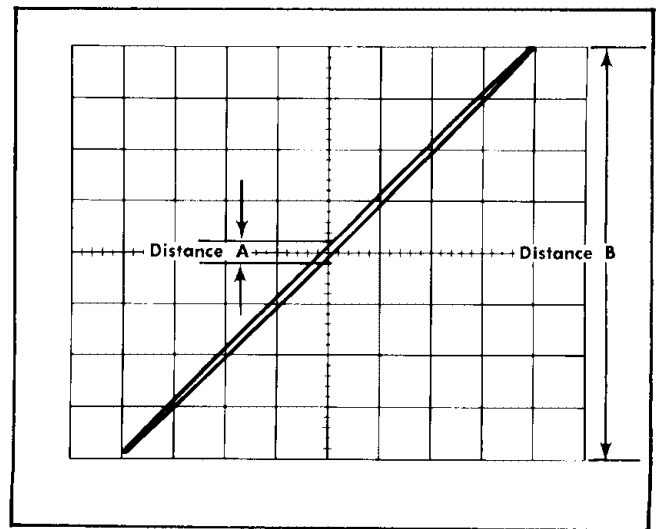


Fig. 5-4. Typical display of the lissajous pattern produced when a common sine-wave is applied to two Type 3A3 Plug-In Units that have approximately  $2^\circ$  of phase difference.

## Performance Check—Type 3A3

i. Set the vertical plug-in compartment Type 3A3 channel 1 + Input Coupling switch to DC.

j. CHECK—Calibration oscilloscope display; any inherent phase difference between the two channels will cause the display to appear as an ellipse whose maximum distance between the two points where the trace crosses the vertical centerline should not exceed 1.4 minor divisions; see Fig. 5-4.

### NOTE

The phase difference between any other combinations of channels (one from each Type 3A3) can be measured using the above procedure.

This completes the performance check of the Type 3A3. Disconnect all test equipment.

## NOTES

Lined writing area for notes.

# SECTION 6

## CALIBRATION

Change information, if any, affecting this section will be found at the rear of the manual.

### Introduction

Complete calibration information for the Type 3A3 is given in this section. This procedure calibrates the instrument to the performance requirements listed in the Characteristics section. If it is desired to merely touch up the calibration, perform only those steps entitled "Adjust . . .". A short-form calibration procedure is also provided for the convenience of the experienced calibrator.

The Type 3A3 should be checked, and recalibrated if necessary, after each 500 hours of operation, or every six months if used infrequently, to assure correct operation and accuracy. The Performance Check section provides a complete check of instrument performance without internal adjustments.

### TEST EQUIPMENT REQUIRED

#### General

The following test equipment, or its equivalent, is required for complete calibration of the Type 3A3. Pictures of the test equipment used in this procedure will be found in the setup pictures which pertain to the steps in which the test equipment is used. Specifications given are the minimum necessary for accurate calibration of the instrument. All test equipment is assumed to be correctly calibrated and operating within the given specifications. If equipment is substituted, it must meet or exceed the specifications of the recommended equipment. Recommended items of calibration equipment are shown in the calibration setup pictures.

For the quickest and most accurate calibration, special calibration fixtures are used where necessary. All calibration fixtures are listed here and can be obtained from Tektronix, Inc. Order by part number through your local Tektronix Field Office or representative.

1. Calibration oscilloscope. Tektronix Type 561A recommended. Note: Any 560-series Oscilloscope (except the Type 560) may be substituted. However, if a Type 565 or RM565 Oscilloscope is used, the step involving two Type 3A3 Plug-In Units in an X-Y configuration cannot be performed.

2. Time base plug-in. Tektronix 2B- or 3B-series Time Base Plug-In recommended. Not required with a Type 565 or RM565 Oscilloscope.

3. (Optional) Vertical plug-in. Must be calibrated and match the Type 3A3 in gain and bandwidth characteristics. Not required if a Type 565 or RM565 Oscilloscope is used. A second Type 3A3 is recommended.

4. Test oscilloscope. Required characteristics: Minimum deflection factor, 10 mV/division; bandwidth, from DC to

1 MHz. Tektronix Type 561A Oscilloscope with 3A-series vertical and 2B- or 3B-series horizontal Plug-In Units, plus a Tektronix P6006 Probe recommended.

5. Square-wave generator. Frequency, 1 kHz, 10 kHz and 100 kHz; risetime, 12 ns maximum; output impedance, 600 ohms or less (without an external termination); output amplitude, variable from about 0 volt to 10 volts peak to peak when terminated into 50 ohms. Tektronix Type 106 Square-Wave Generator recommended.

6. Low frequency constant amplitude sine wave generator. Frequency, variable from below 2 Hz to above 500 kHz; output amplitude, variable from 1 volt to at least 20 volts peak to peak; amplitude regulation accuracy,  $\pm 1\%$ . For example, General Radio Model 1310A Oscillator.

7. Standard amplitude calibrator. Frequency, 1 kHz; output amplitude, 0.5 mV to 50 V peak to peak in a 1-2-5 step sequence; amplitude accuracy,  $\pm 0.25\%$ . Tektronix calibration fixture 067-0502-00 recommended.

8. Cable (two). Impedance, 50 ohm; length 42 inches; connectors, BNC. Tektronix Part No. 012-0057-01.

9. Cable. Impedance, 50 ohm; length, 5 ns; connectors, GR. Tektronix Part No. 017-0502-00.

10. Adapter. Connectors, BNC female to two banana plugs. Tektronix Part No. 013-0094-00.

11. Adapter. Connectors, GR to BNC male. Tektronix Part No. 017-0064-00.

12. Adapter. Connectors, BNC male to two BNC female. Tektronix Part No. 103-0030-00.

13. Adapter. Connectors, GR to BNC female. Tektronix Part No. 017-0063-00.

14.  $2\times$  attenuator. Impedance 50 ohm; accuracy,  $\pm 3\%$ , connectors, BNC. Tektronix Part No. 011-0069-00.

15.  $5\times$  attenuator (two). Impedance, 50 ohm; accuracy,  $\pm 3\%$ ; connectors, BNC. Tektronix Part No. 011-0060-00.

16.  $10\times$  attenuator (three). Impedance, 50 ohm; accuracy,  $\pm 3\%$ ; connectors, BNC. Tektronix Part No. 011-0059-00.

17. Input RC normalizer. Time constant, 1 megohm  $\times$  47 pF; attenuator,  $2\times$ ; connectors, BNC. Tektronix Part No. 011-0068-00.

18. Termination. Impedance, 50 ohm; connectors, BNC; type, feed-thru; accuracy,  $\pm 3\%$ . Tektronix Part No. 011-0049-00.

19. Termination. Impedance, 50 ohm; connectors, GR to BNC male; type, feed-thru; accuracy,  $\pm 3\%$ . Tektronix Part No. 017-0083-00.

## Calibration—Type 3A3

20. Dual-input coupler. Matched signal transfer to each input. Tektronix calibration fixture 067-0525-00 recommended.

21. Plug-in extension. Type, rigid. Tektronix Part No. 013-0034-00.

22. Adjustment tools.

Description	Tektronix Part No.
a. Insulated screwdriver, 1½-inch shaft, non-metallic	003-0000-00
b. Screwdriver, 3-inch shaft	003-0192-00

### CALIBRATION RECORD AND INDEX

This short-form calibration procedure is provided to aid in checking the operation of the Type 3A3. It may be used as a calibration guide by the experienced calibrator, or it may be used as a record of calibration. Since the step numbers and titles used here correspond to those used in the complete procedure, this procedure also serves as an index to locate a step in the complete Calibration Procedure. Performance requirements correspond to those given in the Characteristics section.

Type 3A3, Serial No. \_\_\_\_\_

Calibration Date \_\_\_\_\_

Calibration Technician \_\_\_\_\_

- 1. Adjust Channel 1 Coarse Step Attenuator (Page 6-5) Balance, R131  
Trace at or near horizontal center line with POSITION control at midrange as VOLTS/DIV switch is rotated from 10 mV to 1 mV.
- 2. Adjust Channel 1 Step Attenuator Balance, (Page 6-5) R235  
No trace shift as the VOLTS/DIV switch is rotated between 10 mV and 0.1 mV.
- 3. Adjust Channel 1 Variable DC Balance, (Page 6-5) R159  
No trace shift as VARIABLE (VOLTS/DIV) control is rotated from one extreme to the other.
- 4. Adjust Channel 2 Coarse Step Attenuator (Page 6-6) Balance, R331  
Trace at or near horizontal center line with POSITION control at midrange and VOLTS/DIV switch is rotated from 10 mV to 1 mV.
- 5. Adjust Channel 2 Step Attenuator Balance (Page 6-6) R435  
No trace shift as VOLTS/DIV switch is rotated between 10 mV and 0.1 mV.
- 6. Adjust Channel 2 Variable DC Balance, (Page 6-6) R359  
No trace shift as VARIABLE (VOLTS/DIV) control is rotated from one extreme to the other.
- 7. Adjust Channel 1 Gain and Channel 2 Gain, R175 and R375. (Page 6-7)  
5 Divisions of display with VOLTS/DIV switch at 1 mV position and front-panel GAIN control at mid-range.
- 8. Check Channel 1 Variable (Volts/Div) Control (Page 6-8)  
5 Division display must reduce without jitter to 2 divisions or less as VARIABLE (VOLTS/DIV) is rotated from CAL to full ccw. VOLTS/DIV 10 mV.
- 9. Check Channel 2 Variable (Volts/Div) Control (Page 6-8)  
See Step 8 above.
- 10. Check Channel 2 Noise and Microphonics (Page 6-8)  
Noise: 15  $\mu$ V or less (tangentially measured) with VOLTS/DIV at 0.1 mV and BANDWIDTH switch at 500 kHz.  
Microphonics: 1 major division or less when top of front panel is tapped lightly with VOLTS/DIV at 0.1 mV.
- 11. Check Channel 1 Noise and Microphonics (Page 6-9)  
See Step 10 above.
- 12. Adjust Channel 1 + Input Current Zero (Page 6-9) and - Input Current Zero, R110 and R210.  
Trace shift  $\leq$  1 major division (100 picoamperes) as Input Coupling switch is moved from GND to AC.
- 13. Adjust Channel 2 + Input Current Zero (Page 6-10) and - Input Current Zero, R310 and R410.  
See Step 12 above.
- 14. Check Channel 1 Volts/Division Accuracy (Page 6-12)  
See Table 6-1.
- 15. Check Channel 2 Volts/Division Accuracy (Page 6-12)  
See Table 6-1.
- 16. Check Channel 1 Low Frequency Common Mode Rejection Ratio (Page 6-14)  
10 volt peak to peak 100 Hz sine-wave input signal DC coupled to + and - inputs should produce  $\leq$  2 divisions display.  
VOLTS/DIV 0.1 mV.
- 17. Check Channel 2 Low Frequency Common Mode Rejection Ratio (Page 6-14)  
See Step 16 above.
- 18. Adjust Channel 2 Attenuator Differential (Page 6-14) Balance Controls  
20 volt, 100 Hz sine-wave signal, DC coupled into + and - inputs should produce  $\leq$  20 mV display.  
VOLTS/DIV at positions listed in Table 6-2.
- 19. Adjust Channel 1 Attenuator Differential (Page 6-15) Balance Controls  
See Step 18 above.

- 20. Adjust Channel 1 Cross Neutralization, (Page 6-17)  
C116 and C216  
With 50 mV, 1 kHz square-wave signal to one input connector of the channel, switching opposite Coupling switch of same channel between GND and DC produces negligible effect on 4 division display.
- 21. Adjust Channel 2 Cross Neutralization, (Page 6-17)  
C316 and C416  
See Step 20 above.
- 22. Adjust Channel 1 Input Capacitance (Page 6-19)  
and Attenuator Compensation
- 23. Adjust Channel 2 Input Capacitance (Page 6-19)  
and Attenuator Compensation
- 24. Adjust Channel 1 High Frequency Differential Balance Capacitors C115, C214 and C212 (Page 6-23)  
10 V, 1 kHz sine-wave at + and — input connectors should produce  $\leq 2$  division display VOLTS/DIV 0.1 mV.
- 25. Adjust Channel 2 High Frequency Differential Balance Capacitors, C315, C414 and C412 (Page 6-23)  
See Step 24 above.
- 26. Adjust Channel 2 — Input Attenuator Compensation (Page 6-23)  
Capacitors, C405C, C406C and C407C for High Frequency Common Mode Rejection Ratio. 10 V, 100 kHz sine-wave at + and — inputs. See Table 6-4 for display amplitudes and deflection factors.
- 27. Adjust Channel 1 — Input Attenuator Compensation (Page 6-24)  
Capacitors, C205C, C206C and C207C for High Frequency Common Mode Rejection Ratio  
See Step 26 above.
- 28. Adjust Channel 1 High Frequency Compensation Capacitors (Page 6-26)
- 29. Adjust Channel 2 High Frequency Compensation Capacitors (Page 6-26)
- 30. Check Channel 1 Upper 500 kHz Bandwidth Frequency Response (Page 6-29)  
—3 dB  $\geq$  500 kHz.
- 31. Check Channel 2 Upper 500 kHz Bandwidth Frequency Response (Page 6-29)  
—3 dB  $\geq$  500 kHz.
- 32. Check Channel 2 Upper 5 kHz Bandwidth Frequency Response (Page 6-29)  
—3 dB  $\geq$  5 kHz.
- 33. Check Channel 1 Upper 5 kHz Bandwidth Frequency Response (Page 6-30)  
—3 dB  $\geq$  5 kHz.
- 34. Check Channel 1 AC Low Frequency Response (Page 6-30)  
—3 dB  $\leq$  2 Hz.
- 35. Check Channel 2 AC Low Frequency Response (Page 6-30)  
—3 dB  $\leq$  2 Hz.

- 36. Adjust Trigger Amplifier Output DC (Page 6-33)  
Balance R511, R541 and DC Level, R525, R555 and R565  
Pins 3 and 8 of V583 at 0 V.
- 37. Adjust Trigger Amplifier High Frequency Compensation (Page 6-36)  
C508, C518, C538, C548, C561 and C569
- 38. Check Alternate Mode of Operation (Page 6-37)  
Channels alternately displayed at all sweep rates.
- 39. Check Chopped Mode of Operation (Page 6-37)  
Square-wave display cycle should occupy 4 to 6.6  $\mu$ s of sweep. All vertical display transients should be blanked during switching with oscilloscope CRT cathode selector at chopped blanking.
- 40. (Optional Step) Check Dual-Trace X-Y Operation (Page 6-37)

## CALIBRATION PROCEDURE

### General

The following procedure is arranged in a sequence which allows the Type 3A3 to be calibrated with the least interaction of adjustments and reconnection of equipment. However, some adjustments affect the calibration of other circuits. In this case, it will be necessary to check the operation of other parts of the instrument. When a step interacts with others, the steps to be checked are noted in the "INTERACTION— . . . . . " step.

Any needed maintenance should be performed before proceeding with calibration. Troubles which become apparent during calibration should be corrected using the techniques given in the Maintenance section.

The steps titled "Adjust . . . . ." in the following procedure provide a check of instrument performance, whenever possible, before the adjustment is made. The symbol **●** is used to identify the steps in which an adjustment is made. To prevent recalibration of other circuits when performing a partial calibration, readjust only if the listed tolerance is not met. However, when performing a complete calibration, best overall performance will be provided if each adjustment is made to the exact setting, even if the "CHECK— . . . ." is within the allowable tolerance.

In the following procedure, a test equipment setup picture is shown for each major group of adjustments and checks. Following each setup picture is a complete list of front-panel control settings for the Type 3A3, calibration oscilloscope and 2B- or 3B-series plug-in. To aid in locating individual controls which have been changed during complete calibration, these control names are printed in bold type. If only a partial calibration is performed, start with the nearest setup preceding the desired portion. Type 3A3 front-panel control titles referred to in this procedure are capitalized (e.g., POSITION). Internal adjustment titles are initial capitalized only (e.g., CH 1 Gain).

The following procedure uses the equipment listed under Equipment Required. If equipment is substituted, control settings or test equipment setup may need to be altered to meet the requirements of the equipment used.

## Calibration—Type 3A3

### NOTE

All waveforms shown in this procedure are actual waveform photographs taken with a Tektronix Oscilloscope Camera System.

### Preliminary Procedure

1. Remove the left and right side covers from the calibration oscilloscope.
2. Install the Type 3A3 into the vertical plug-in compartment of the calibration oscilloscope via a rigid plug-in extension.

3. Install a 2B- or 3B-series plug-in into the horizontal plug-in compartment of the calibration oscilloscope.

4. Set the front-panel controls of the Type 3A3, calibration oscilloscope and horizontal plug-in as described below.

5. Connect the calibration oscilloscope directly to a power supply of appropriate voltage.

6. Set the calibration oscilloscope power switch to on. Allow at least 20 minutes warm up at 25° C,  $\pm 5^\circ$  C, for checking the instrument to the given accuracy.

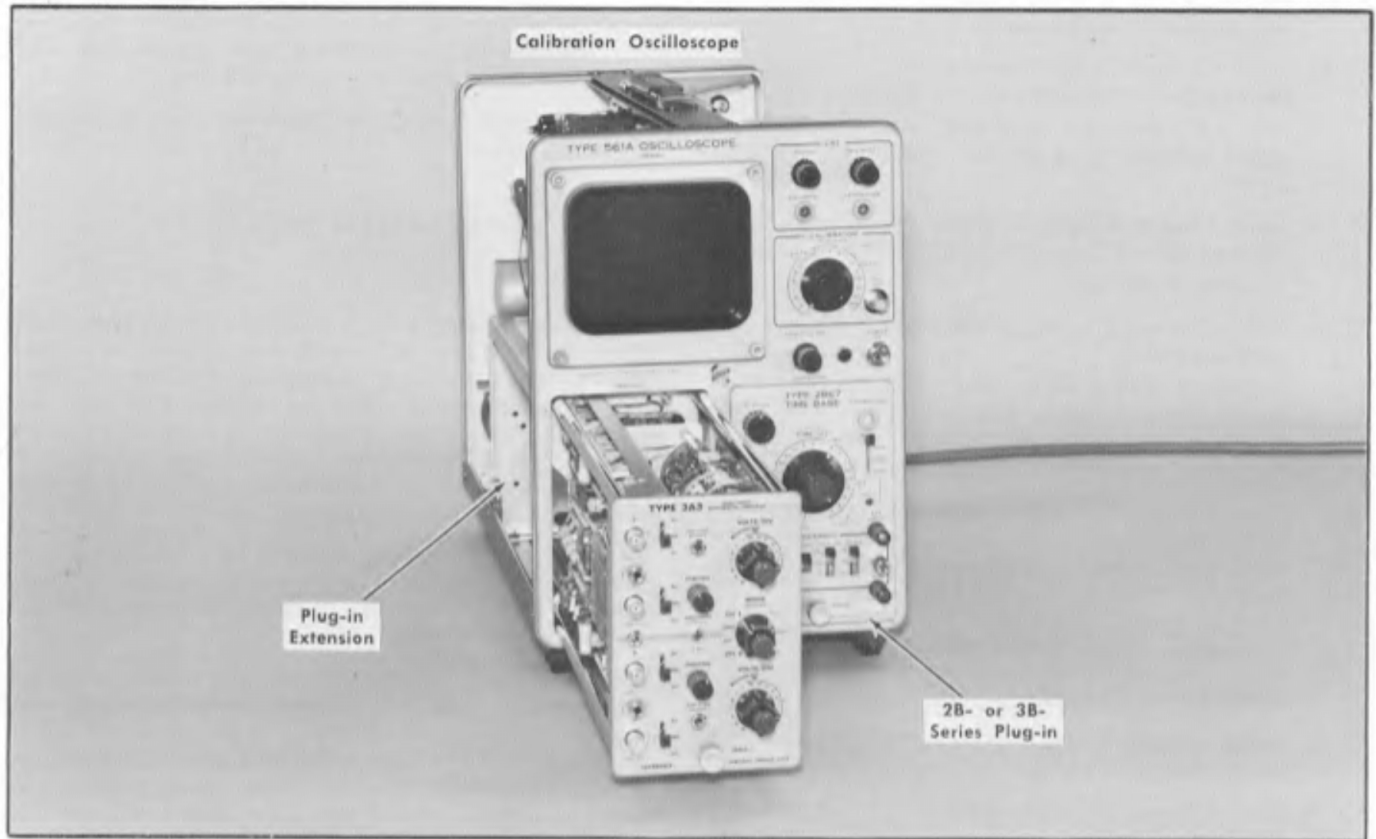


Fig. 6-1. Initial test equipment setup for steps 1 through 6.

	<b>Type 3A3</b>		<b>MODE</b>	<b>CH 1</b>
VOLTS/DIV (both channels)	1 mV		TRIGGER	COMP
VARIABLE (VOLTS/DIV) (both channels)	CAL		BANDWIDTH	500 kHz
STEP ATTEN BALANCE (both channels)	Midrange		GAIN	As is
POSITION (both channels)	Midrange			
+ Input Coupling (both channels)	GND			
- Input Coupling (both channels)	GND			
			<b>Calibration Oscilloscope</b>	
			Intensity	As desired
			Focus	Adjusted for a well defined display



Astigmatism	Adjusted for a well defined display
Alignment	As desired
Calibrator	Off
Power	On
Scale Illum	As desired

**2B- or 3B-Series Plug-In**

Calibration	Adjusted as per instruction manual procedure
Position	Midrange
Mode	Normal
Time/Div	0.5 ms
Variable (Time/Div)	Calibrated
5X Mag	Off
Stability	Adjusted as per instruction manual procedure
Source	Internal
Coupling	AC slow
Slope	+
Level	Free run

**1. Adjust Channel 1 Coarse Step Attenuator Balance**

- a. Test equipment setup is shown in Fig. 6-1.
- b. CHECK—Trace position; should be within  $\pm 1$  major division of the graticule center horizontal line.
- c. ADJUST—Coarse step Atten Bal control, R131, (see Fig. 6-2) until the trace is positioned to the graticule center horizontal line.

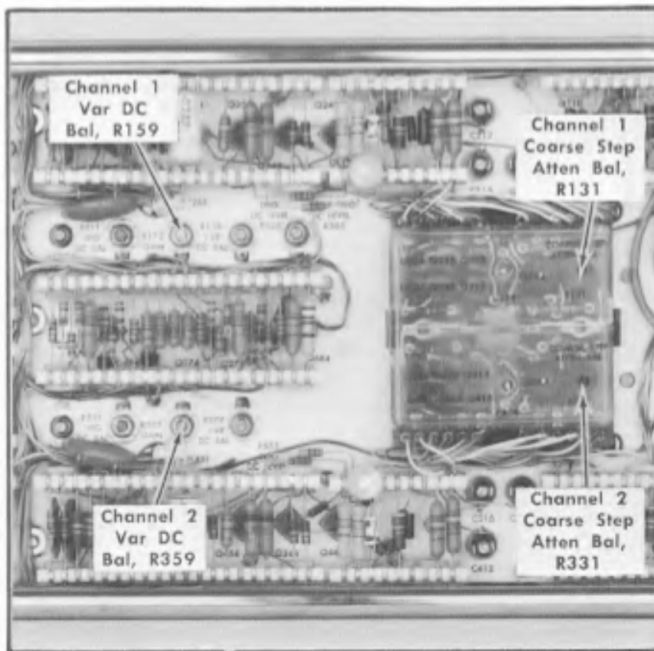


Fig. 6-2. Location of channel 1 Coarse Step Atten Bal control, R131, channel 1 Var DC Bal, R159, channel 2 Coarse Step Atten Bal control, R331 and channel 2 Var DC Bal, R359.



Fig. 6-3. Location of channel 1 STEP ATTEN BALANCE control, R235 and channel 2 STEP ATTEN BALANCE control, R435.

**2. Adjust Channel 1 Step Attenuator Balance**

Step 1 must be performed before this step.

- a. Set the channel 1 VOLTS/DIV switch to 10 mV.
- b. Rotate the channel 1 VOLTS/DIV switch back and forth between 10 mV and 0.1 mV.
- c. CHECK—Trace shift; there must be no trace shift as part b of this step is performed.
- d. ADJUST—STEP ATTEN BALANCE control, R235, (see Fig. 6-3) for no trace shift as part b of this step is performed.

**3. Adjust Channel 1 Variable DC Balance**

Steps 1 and 2 must be performed prior to this step.

- a. Set the channel 1 VOLTS/DIV switch to 10 mV.
- b. Rotate the channel 1 VARIABLE (VOLTS/DIV) control from one extreme to the other.
- c. CHECK—Trace shift; there must be no trace shift as part b of this step is performed.
- d. ADJUST—Var DC Bal control, R159, (see Fig. 6-2) for no trace shift as part b is performed.
- e. Return the channel 1 VARIABLE (VOLTS/DIV) control to CAL.
- f. Repeat step 2, then, omitting this step, proceed to step 4.

**Calibration—Type 3A3**

**4. Adjust Channel 2 Coarse Step Attenuator Balance** ①

- a. Set the Type 3A3 MODE switch to CH 2.
- b. CHECK—Trace position; should be within  $\pm 1$  major division of the graticule center horizontal line.
- c. ADJUST—Coarse Step Atten Bal control, R331, (see Fig. 6-2) until the trace is positioned as close as possible to the graticule center horizontal line.

**5. Adjust Channel 2 Step Attenuator Balance** ①

Step 4 must be performed before this step.

- a. Set the channel 2 VOLTS/DIV switch to 10 mV.
- b. Rotate the channel 2 VOLTS/DIV switch back and forth between 10 mV and 0.1 mV.
- c. CHECK—Trace shift; there must be no trace shift as part b of this step is performed.

- d. ADJUST—STEP ATTEN BALANCE control, R435, (see Fig. 6-3) for no trace shift as part b is performed.

**6. Adjust Channel 2 Variable DC Balance** ①

Steps 4 and 5 must be performed ahead of this step.

- a. Set the channel 2 VOLTS/DIV switch to 10 mV.
- b. Rotate the channel 2 VARIABLE (VOLTS/DIV) control from one extreme to the other.
- c. CHECK—Trace shift; there must be no trace shift as part b of this step is performed.
- d. ADJUST—Var DC Bal control, R359, (see Fig. 6-2) for no trace shift as part b is performed.
- e. Return the channel 2 VARIABLE (VOLTS/DIV) control to CAL.
- f. Repeat step 5, then, omitting this step, proceed to step 7.

**NOTES**

---

---

---

---

---

---

---

---

---

---

---

---

---

---

---

---

---

---

---

---

---

---

---

---

---

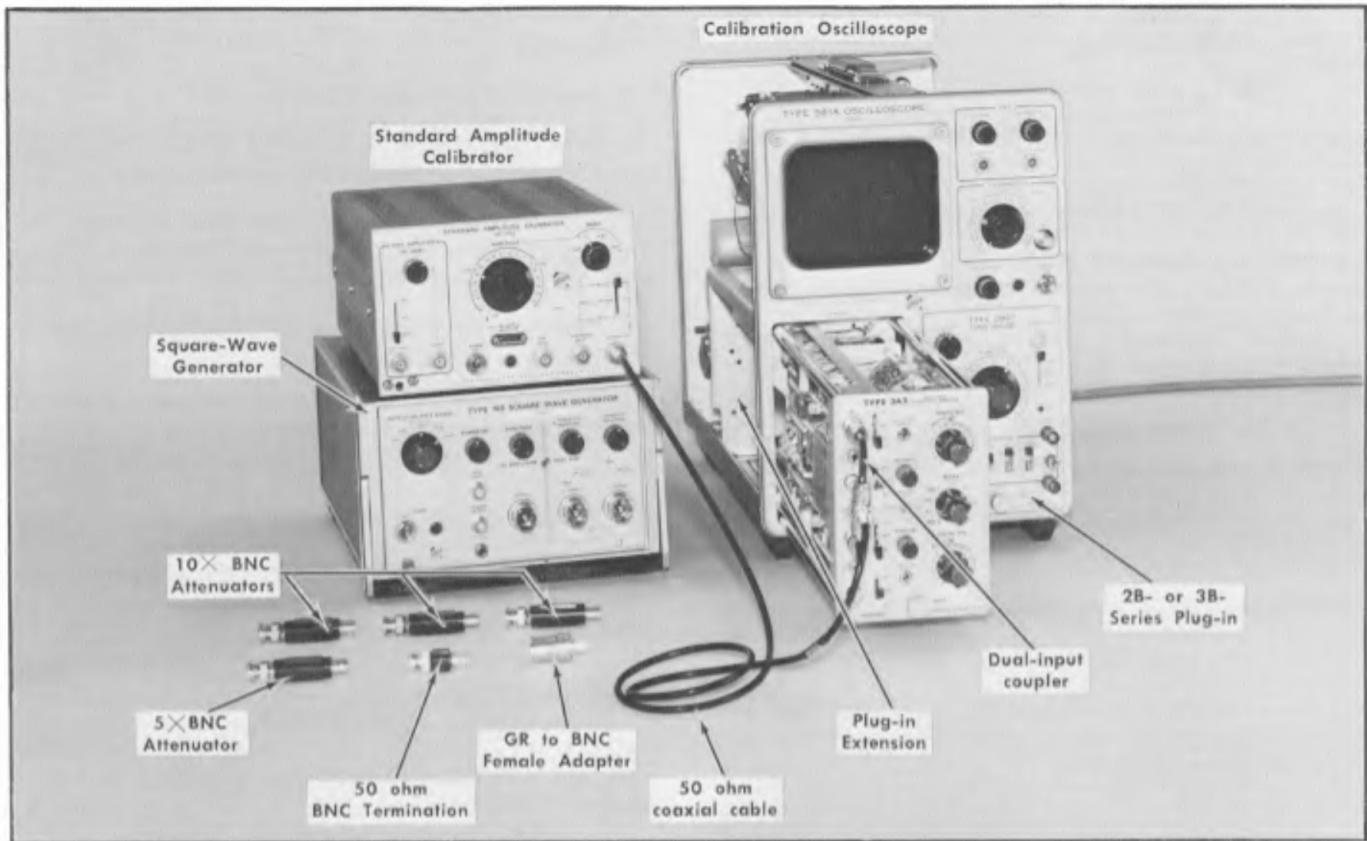


Fig. 6-4. Initial test equipment setup for steps 7 through 13.

Type 3A3		2B- or 3B-Series Plug In	
VOLTS/DIV (both channels)	1mV	Calibration	Adjusted as per instruction manual procedure
VARIABLE (VOLTS/DIV) (both channels)	CAL	Position	Midrange
STEP ATTEN BALANCE (both channels)	As is	Mode	Normal
POSITION (both channels)	Midrange	Time/Div	0.5 ms
<b>+ Input Coupling (both channels)</b>	<b>DC</b>	Variable (Time/Div)	Calibrated
- Input Coupling (both channels)	GND	5x Mag	Off
MODE	ALT	Stability	Adjusted as per instruction manual procedure
TRIGGER	COMP	Source	Internal
BANDWIDTH	500 kHz	Coupling	AC slow
GAIN	Midrange	Slope	+
		Level	Automatic

**Calibration Oscilloscope**

Intensity	As desired
Focus	Adjusted for a well defined display
Astigmatism	Adjusted for a well defined display
Alignment	As desired
Calibrator	Off
Power	On
Scale Illum	As desired

**7. Adjust Channel 1 Gain and Channel 2 Gain**

- a. Test equipment setup is shown in Fig. 6-4.
- b. Connect one end of a dual input coupler to the channel 1 + input connector and the other end to the channel 2 + input connector.
- c. Connect a 5 mV, 1 kHz square-wave signal from a standard amplitude calibrator via a 50 ohm coaxial cable to the center connector of the dual-input coupler.

## Calibration—Type 3A3

d. With the channel 1 POSITION control, position the channel 1 display on the graticule so its amplitude can be measured.

e. CHECK—Channel 1 display amplitude; should be exactly 5 major divisions.

f. ADJUST—CH 1 Gain Control, R175, (see Fig. 6-5) for a channel 1 display amplitude of exactly 5 major divisions.

g. With the channel 2 POSITION control, position the channel 2 display to a position on the graticule convenient for measuring display amplitude.

h. CHECK—Channel 2 display amplitude; should be exactly 5 major divisions.

i. ADJUST—CH 2 Gain control R375, (see Fig. 6-5) for a channel 2 display amplitude of exactly 5 major divisions.

j. The test equipment remains connected for step 8.

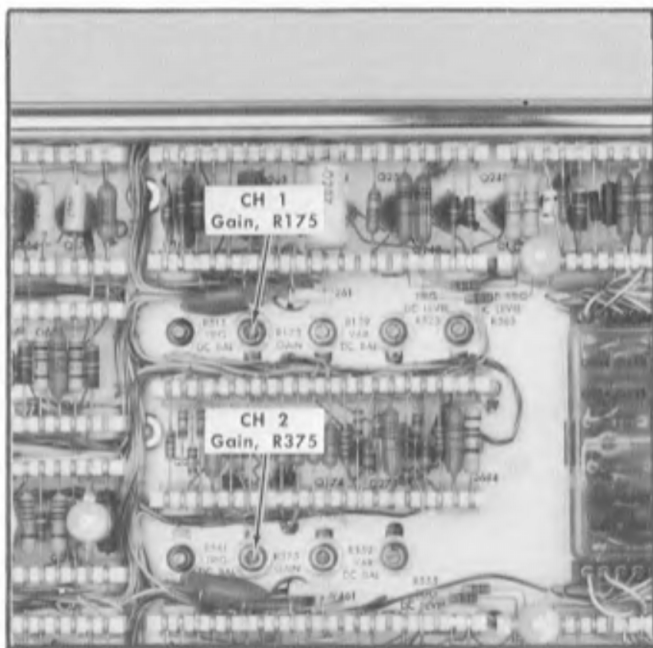


Fig. 6-5. Location of CH 1 Gain, R175, CH 2 Gain, R375.

### 8. Check Channel 1 Variable (VOLTS/DIV) Control

- Set the MODE switch to CH 1.
- Rotate the channel 1 VARIABLE (VOLTS/DIV) control from CAL position slowly counterclockwise.
- CHECK—Display behavior and final amplitude; the display should have slowly decreased in amplitude, without any jitter, to a display amplitude of 2 major divisions or less.
- Return the channel 1 VARIABLE (VOLTS/DIV) control to CAL.
- The test equipment remains connected for step 9.

### 9. Check Channel 2 Variable (VOLTS/DIV) Control

- Set the MODE switch to CH 2.
- Rotate the channel 2 VARIABLE (VOLTS/DIV) control from CAL position slowly to fully counterclockwise.
- CHECK—Display behavior and final amplitude; the display should have slowly decreased in amplitude, without any jitter, to a display amplitude of 2 major divisions or less.
- Return the channel 2 VARIABLE (VOLTS/DIV) control to CAL.
- Disconnect the standard amplitude calibrator, dual-input coupler and the 50 ohm coaxial cable.

### 10. Check Channel 2 Noise and Microphonics

- Set the channel 2 VOLTS/DIV switch to 0.1 mV.
- Set the level control for the horizontal plug-in to free run.
- Connect a 10 kHz, square-wave signal from a square-wave generator via a GR to BNC female adapter, a 5× BNC attenuator, three 10× BNC attenuators, 50 ohm coaxial cable and a 50 ohm BNC termination to the Type 3A3 channel 2 + input connector.

#### NOTE

The power cord to the square-wave generator must be ungrounded for this check. To accomplish this, either use a 3-to-2 wire adapter at the wall outlet, or invert the female end of the power cord at the square-wave generator. After this has been done, the case of the square-wave generator may be at a voltage above ground, and SHOCK HAZARD may exist.

- Decrease the output signal amplitude of the square-wave generator to the point where the two separate traces just merge into one trace (with no perceptible dark separation) on the CRT of the calibration oscilloscope.
- Remove one of the 10× BNC attenuators from the signal path.
- CHECK—Calibration oscilloscope display amplitude; 1.5 major divisions or less. To obtain an actual voltage figure, measure the display amplitude in microvolts and divide this figure by 10.
- Disconnect the square-wave generator, GR to BNC female adapter, 5× BNC attenuator, two 10× BNC attenuators, 50 ohm coaxial cable and the 50 ohm BNC termination.
- Set the Type 3A3 channel 2 + Input Coupling switch to GND.
- Set the time/div switch of the horizontal plug-in to 10 ms.
- Tap lightly on the top of the Type 3A3 front-panel.

k. CHECK—Amount of microphonics; peak to peak microphonics display amplitude must be 1 major division or less.

### 11. Check Channel 1 Noise and Microphonics

- a. Set the MODE switch to CH 1.
- b. Set the channel 1 VOLTS/DIV switch to 0.1 mV.
- c. Set the time/div switch for the horizontal plug-in to 0.5 ms.
- d. Connect a 10 kHz, square-wave generator via a GR to BNC female adapter, a 5× BNC attenuator, three 10× BNC attenuators, 50 ohm coaxial cable and a 50 ohm BNC termination to the Type 3A3 channel 1 + input connector. See NOTE in Step 10.
- e. Decrease the output signal amplitude of the square-wave generator to the point where the two separate traces just merge into one trace (with no perceptible dark separation) on the CRT of the calibration oscilloscope.
- f. Remove one of the 10× BNC attenuators from the signal path.
- g. CHECK—Calibration oscilloscope display amplitude; 1.5 major divisions or less. To obtain an actual voltage figure, measure the display amplitude in microvolts and divide this figure by 10.
- h. Disconnect the square-wave generator, GR to BNC female adapter, two 10× BNC attenuators, 50 ohm coaxial cable and the 50 ohm BNC termination.
- i. Set the Type 3A3 channel 1 + Input Coupling switch to GND.
- j. Set the time/div switch of the horizontal plug-in to 10 ms.
- k. Tap lightly on the top of the Type 3A3 front-panel.
- l. CHECK—Amount of microphonics; peak to peak microphonics display amplitude must be 1 major division or less.

### 12. Adjust Channel 1 + Input Current Zero $\oplus$ and — Input Current Zero

- a. Set the Type 3A3 TRIGGER switch to CH 1 and the BANDWIDTH switch to 5 kHz.
- b. Set the time/div switch of the horizontal plug-in to 0.5 ms.
- c. Position the trace to the graticule center horizontal line with the channel 1 POSITION control.
- d. Connect a 50 ohm BNC termination to the channel 1 + input connector.
- e. Change the channel 1 Input coupling switch back and forth from GND to AC.
- f. CHECK—Trace movement; should not shift more than 1 major division (one major division corresponds to 100 pico-amperes) as part e of this step is being accomplished. Ignore any transient movements when measuring the amount of trace position change.

g. ADJUST—+ Input Current Zero, R110, (see Fig. 6-6) for the smallest possible amount of trace shift as part e is being accomplished. If it is not possible to reduce the trace drift below 1 major division, it may be necessary to replace D113 or Q114.

- h. Set the channel 1 + Input Coupling switch to GND.
- i. Remove the 50 ohm BNC termination from the channel 1 + Input connector.

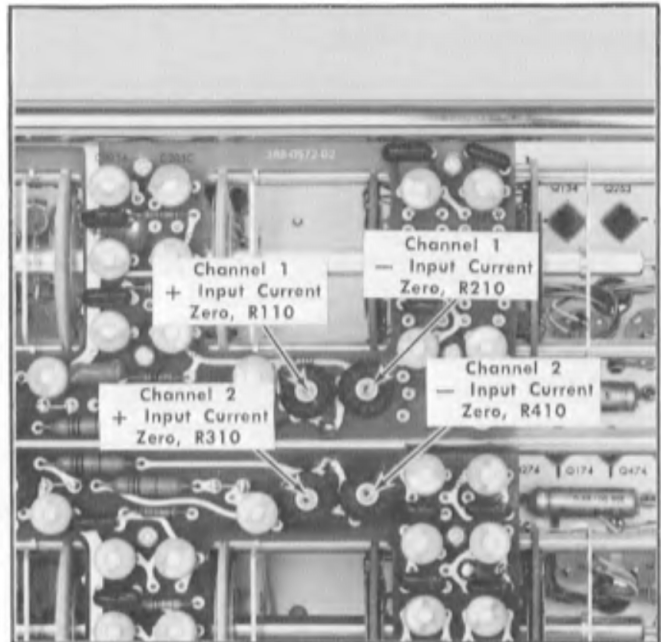


Fig. 6-6. Location of channel 1 + Input Current Zero control, R110, channel 1 — Input Current Zero control, R210, channel 2 + Input Current Zero control, R310 and channel 2 — Input Current Zero control, R410.

- j. Position the trace to the graticule center horizontal line with the channel 1 POSITION control.
- k. Connect a 50 ohm BNC termination to the channel 1 —Input connector.
- l. Change the channel 1 — Input Coupling switch back and forth from GND to AC.
- m. CHECK—Trace movement; should not shift more than 1 division (one major division corresponds to 100 pico-amperes) as part l of this step is being accomplished. Ignore any transient movements when measuring the amount of trace position change.
- n. ADJUST—Input Current Zero, R210, (see Fig. 6-6) for the smallest possible amount of trace drift as part l is being accomplished. If it is not possible to reduce the trace drift below 1 major division, it may be necessary to replace D213 or Q114.
- o. Set the channel 1 — Input Coupling switch to GND.
- p. Remove the 50-ohm BNC termination from the channel 1—Input connector.





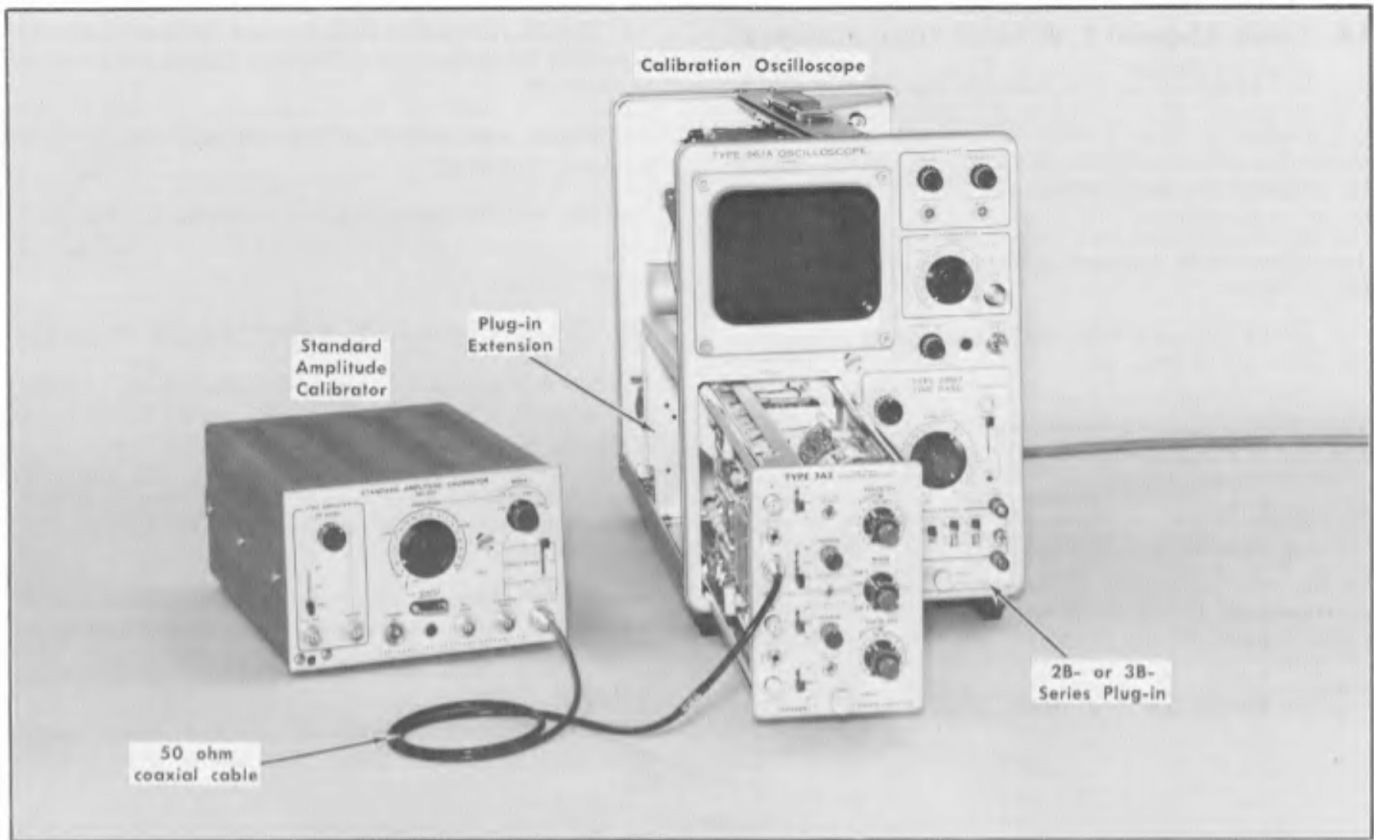


Fig. 6-7. Initial test equipment setup for steps 14 through 15.

<b>Type 3A3</b>		Astigmatism	Adjusted for a well defined display
VOLTS/DIV (both channels)	0.1 mV	Alignment	As desired
VARIABLE (VOLTS/DIV) (both channels)	CAL	Calibrator	Off
STEP ATTEN BALANCE (both channels)	As is	Power	On
<b>POSITION</b> (both channels)	Midrange	Scale Illum	As desired
+ Input Coupling (both channels)	<b>GND</b>	<b>2B- or 3B-Series Plug-In</b>	
- Input Coupling (channel 1)	<b>DC</b>	Calibration	Adjusted as per instruction manual procedure
- Input Coupling (channel 2)	GND	Position	Midrange
<b>MODE</b>	<b>CH 1</b>	Mode	Normal
<b>TRIGGER</b>	<b>COMP</b>	Time/Div	0.5 ms
<b>BANDWIDTH</b>	<b>500 kHz</b>	Variable (Time/Div)	Calibrated
<b>GAIN</b>	<b>As is</b>	5× Mag	Off
		Stability	Adjusted as per instruction manual procedure
		Source	Internal
		Coupling	AC Slow
		Slope	+
		<b>Level</b>	<b>Free Run</b>
<b>Calibration Oscilloscope</b>			
Intensity	As desired		
Focus	Adjusted for a well defined display		

14. Check Channel 1 Volts/Division Accuracy

- a. Test equipment setup is shown in Fig. 6-7.
- b. Connect a 0.5 mV, 1 kHz square-wave signal from a standard amplitude calibrator via a 50 ohm coaxial cable to the channel 1 — Input connector.
- c. Set the standard amplitude calibrator output square-wave signal to the appropriate amplitude as listed in Table 6-1.
- d. Set the channel 1 VOLTS/DIV switch to the appropriate position listed in Table 6-1.

TABLE 6-1

VOLTS/DIV Accuracy Check

Square-Wave Signal Amplitude Peak to Peak	Type 3A3 VOLTS/DIV Switch	Deflection Amount and Tolerance in Major Divisions
0.5 mV	.1 mV	5, ±0.15
1 mV	.2 mV	5, ±0.15
2 mV	.5 mV	4, ±0.12
5 mV	1 mV	5, ±0.15
10 mV	2 mV	5, ±0.15
20 mV	5 mV	4, ±0.12
50 mV	10 mV	5, ±0.15
0.1 V	20 mV	5, ±0.15
0.2 V	50 mV	4, ±0.12
0.5 V	.1 V	5, ±0.15
1 V	.2 V	5, ±0.15
2 V	.5 V	4, ±0.12
5 V	1 V	5, ±0.15
10 V	2 V	5, ±0.15
20 V	5 V	4, ±0.12
50 V	10 V	5, ±0.15

e. CHECK—Amount of deflection; see Table 6-1 for correct amount of DC deflection and tolerance (ignore any overshoot or rounding).

f. Repeat parts c through e of this step until the table has been completed.

g. The test equipment remains connected for step 15.

15. Check Channel 2 Volts/Division Accuracy

a. Set the channel 1 — Input Coupling switch to GND, the channel 2 — Input Coupling to DC and the MODE switch to CH 2.

b. Disconnect the 50 ohm coaxial cable from the channel 1 — Input connector and connect it to the channel 2 — Input connector.

c. Set the standard amplitude calibrator output square-wave signal amplitude control for a signal amplitude of 0.5 mV peak to peak, the starting signal amplitude in Table 6-1.

d. Set the standard amplitude calibrator output square-wave signal to the appropriate amplitude as listed in Table 6-1.

e. Set the channel 2 VOLTS/DIV switch to the appropriate position listed in Table 6-1.

f. CHECK—Amount of deflection; see Table 6-1 for correct amount of DC deflection and tolerance.

g. Repeat parts d through f of the step until the table has been completed.

h. Disconnect the standard amplitude calibrator and the 50 ohm coaxial cable.

NOTES

---

---

---

---

---

---

---

---

---

---

---

---

---

---

---

---



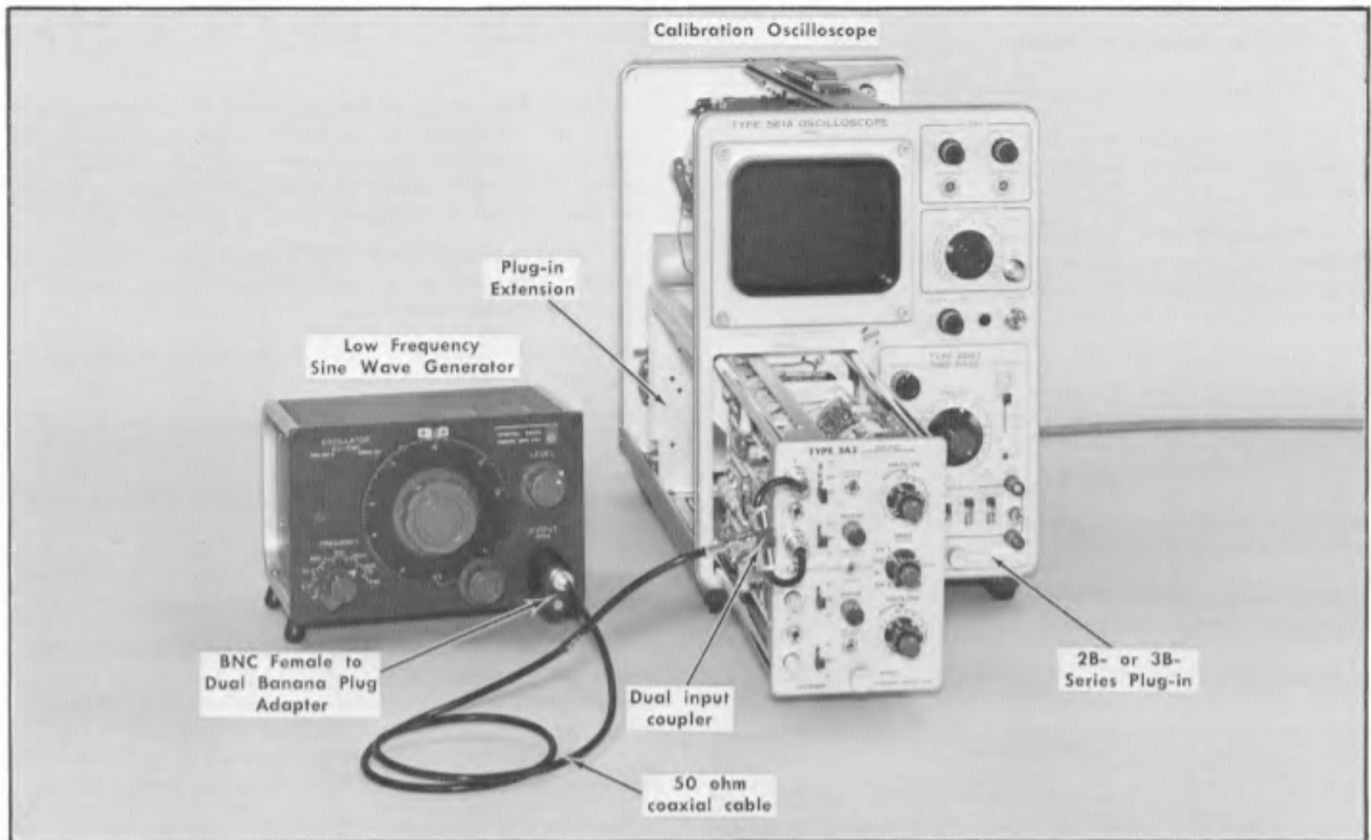


Fig. 6-8. Initial test equipment setup for steps 15 through 19.

	<b>Type 3A3</b>	Astigmatism	Adjusted for a well defined display
<b>VOLTS/DIV</b> (both channels)	<b>2 V</b>	Alignment	As desired
<b>VARIABLE (VOLTS/DIV)</b> (both channels)	<b>CAL</b>	Calibrator	Off
<b>STEP ATTEN BALANCE</b> (both channels)	<b>As is</b>	Power	On
<b>POSITION</b> (both channels)	<b>Midrange</b>	Scale Illum	As desired
<b>+ Input Coupling</b> (channel 1)	<b>DC</b>		
<b>+ Input Coupling</b> (channel 2)	<b>GND</b>	<b>2B- or 3B-Series Plug-In</b>	
<b>- Input Coupling</b> (both channels)	<b>GND</b>	Calibration	Adjusted as per instruction manual procedure
<b>MODE</b>	<b>CH 1</b>	Position	Midrange
<b>TRIGGER</b>	<b>COMP</b>	Mode	Normal
<b>BANDWIDTH</b>	<b>500 kHz</b>	<b>Time/Div</b>	<b>1 ms</b>
<b>GAIN</b>	<b>As is</b>	Variable (Time/Div)	Calibrated
		<b>5X Mag</b>	Off
		Stability	Adjusted as per instruction manual procedure
		Source	Internal
		Coupling	AC Slow
<b>Calibration Oscilloscope</b>		Slope	+
Intensity	As desired	<b>Level</b>	<b>Automatic</b>
Focus	Adjusted for a well defined display		

### 16. Check Channel 1 Low Frequency Common Mode Rejection Ratio

- a. Test equipment setup is shown in Fig. 6-8.
- b. Connect one end of a dual-input coupler to the channel 1 + input connector and the other to the channel 1 input connector.
- c. Connect a 10 V, 100 Hz sine wave signal from a low frequency sine wave generator via a BNC female to banana plug adapter and a 50 ohm coaxial cable to the center connector of the dual-input coupler.
- d. After setting the output signal amplitude of the low frequency sine wave generator to 10 V, set the Type 3A3 channel 1 VOLTS/DIV switch to 0.1 mV and the channel 1 — Input Coupling switch to DC.
- e. With the channel 1 POSITION control, position the channel 1 display to a graticule position convenient for measuring display amplitude.
- f. CHECK—Channel 1 display amplitude; should not be more than 2 major divisions.
- g. The test equipment remains connected for step 17.

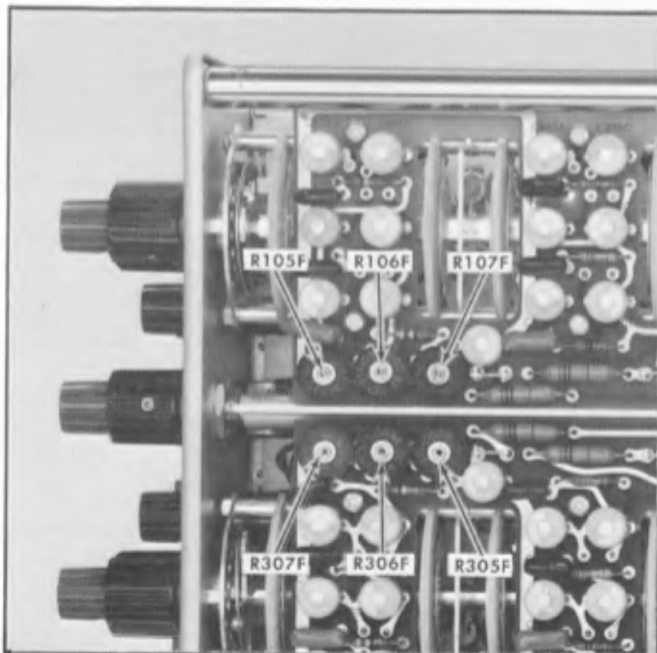


Fig. 6-9. Location of Attenuator Differential Balance adjustments for channels 1 and 2.

### 17. Check Channel 2 Low Frequency Common Mode Rejection Ratio

- a. Set the channel 2 + Input Coupling switch to DC and the MODE switch to CH 2.

- b. Disconnect the dual-input Coupler from the channel 1 Input connectors and connect it to the channel 2 input connectors.

- c. With the output of the low frequency sine-wave generator still connected to the dual-input Coupler, set the sine-wave generator output signal amplitude to 10 V, then set the Type 3A3 channel 2 VOLTS/DIV switch to 0.1 mV and the channel 2 — Input Coupling switch to DC.

- d. With the channel 2 POSITION control, position the channel 2 display to a graticule position convenient for measuring display amplitude.

- e. CHECK—Channel 2 display amplitude; should not be more than 2 major divisions.

- f. The test equipment remains connected for step 18.

### 18. Adjust Channel 2 Attenuator Differential Balance Controls

- a. Set the channel 2 VOLTS/DIV switch to 5 V and the channel 2 — Input Coupling switch to GND.

- b. With the output of the low frequency sine-wave generator still connected to the dual-input coupler, set the sine-wave generator output signal amplitude to 20 V (output frequency still 100 Hz) then set the Type 3A3 channel 2 VOLTS/DIV switch to the position to be checked as listed in Table 6-2 and the channel 2 — Input Coupling switch to DC.

- c. With the channel 2 POSITION control, position the channel 2 display to a graticule position convenient for measuring display amplitude.

- d. CHECK—Channel 2 display amplitude; should be equal to or less than 20 mV. No signal amplitude at all is preferred.

- e. ADJUST—See table 6-2 and Fig 6-9 for appropriate component number and location to be adjusted for minimum display amplitude.

- f. Set the Type 3A3 channel 2 VOLTS/DIV switch to the next position listed in Table 6-2.

- g. Repeat parts c through f of this step until Table 6-2 is completed for channel 2.

- h. The test equipment remains connected for step 19.

TABLE 6-2

Attenuator Differential Balance Adjustments

VOLTS/DIV Switch Setting for Channel being Checked	Channel 1 Adjustment	Channel 2 Adjustment
20 mV	R105F	R305F
0.2 V	R106F	R306F
2 V	R107F	R307F



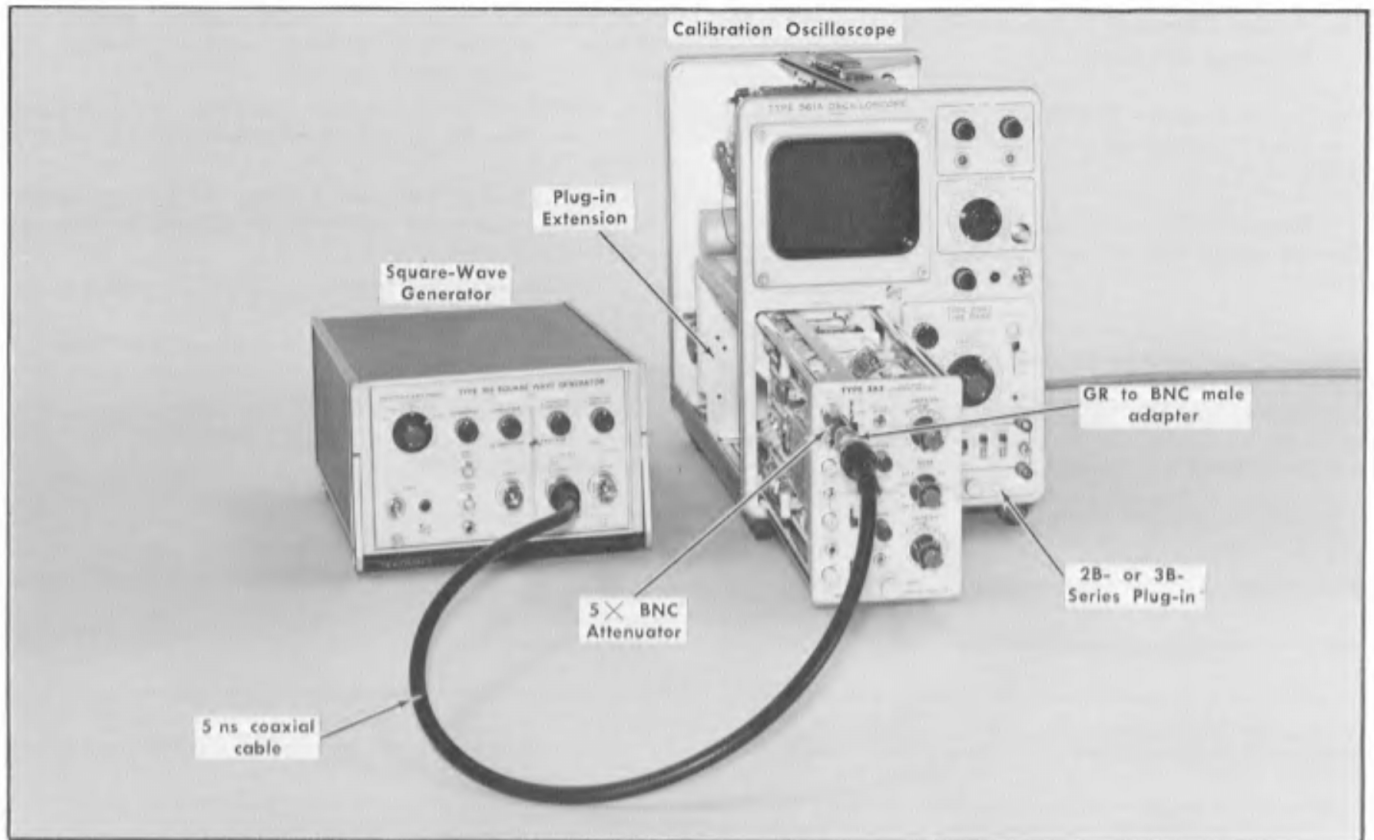


Fig. 6-10. Initial test equipment setup for steps 20 and 21.

<b>Type 3A3</b>		<b>Calibration Oscilloscope</b>	
VOLTS/DIV (both channels)	10 mV	Astigmatism	Adjusted for a well defined display
VARIABLE (VOLTS/DIV) (both channels)	CAL	Alignment	As desired
STEP ATTEN BALANCE (both channels)	As is	Calibrator	Off
<b>POSITION</b> (both channels)	<b>Midrange</b>	Power	On
+ Input Coupling (channel 1)	GND	Scale Illum	As desired
+ Input Coupling (channel 2)	GND	<b>2B- or 3B-Series Plug-In</b>	
- Input Coupling (both channels)	GND	Calibration	Adjusted as per instruction manual procedure
MODE	CH 1	Position	Midrange
TRIGGER	COMP	Mode	Normal
BANDWIDTH	500 kHz	<b>Time/Div</b>	<b>0.5 ms</b>
GAIN	As is	Variable (Time/Div)	Calibrated
		5x Mag	Off
		Stability	Adjusted as per instruction manual procedure
		Source	Internal
		Coupling	AC slow
Intensity	As desired	Slope	+
Focus	Adjusted for a well defined display	<b>Level</b>	<b>Adjusted for stable display</b>

## 20. Adjust Channel 1 Cross Neutralization ①

- a. Test equipment setup is shown in Fig. 6-10.
- b. Connect a 1 kHz, fast rise square-wave signal having a positive-going transition from a square-wave generator via a 5 ns coaxial cable a GR to BNC male adapter and a 5× BNC attenuator to the Type 3A3 channel 1 + input connector.
- c. Adjust the square-wave generator so a 50 mV square-wave signal is applied to the channel 1 + input connector.
- d. Change the channel 1 — Input Coupling switch back and forth from GND to DC.
- e. CHECK—Displayed waveform; there should be very little if any effect on the waveform as part d of this step is accomplished.
- f. ADJUST—C116, see Fig. 6-11, for minimum waveform change as part d of this step is being accomplished.
- g. Disconnect the input square-wave signal from the channel 1 + input connector and connect it to the channel 1 — input connector.
- h. Set the channel 1 + Input Coupling switch to GND and the channel 1 — Input Coupling switch to DC.
- i. Change the channel 1 + Input Coupling switch back and forth from GND to DC.
- j. CHECK—Displayed waveform; there should be very little if any effect on the waveform as part i of this step is accomplished.
- k. ADJUST—C216, see Fig. 6-11, for minimum waveform change as part i of this step is being accomplished.
- l. The test equipment remains connected for step 21.

## 21. Adjust Channel 2 Cross Neutralization ①

- a. Set the channel 2 + Input Coupling switch to DC and the MODE switch to CH 2.
- b. Disconnect the input square-wave signal from the channel 1 — input connector and connect it to the channel 2 + input connector.
- c. Adjust the input square-wave signal for a 50 mV signal amplitude at the channel 2 + input connector.
- d. Change the channel 2 — Input Coupling switch back and forth from GND to DC.

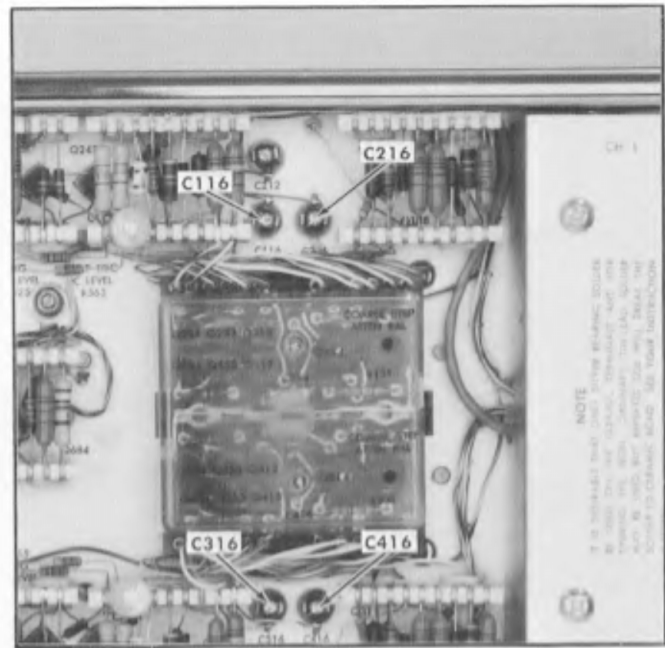


Fig. 6-11. Location of channels 1 and 2 cross neutralizing capacitors.

- e. CHECK—Displayed waveform; there should be very little if any effect on the waveform as part d of this step is accomplished.
- f. ADJUST—C316, see Fig. 6-11, for minimum waveform change as during part d of this step is being accomplished.
- g. Disconnect the input square-wave signal from the channel 2 + input connector and connect it to the channel 2 — Input connector.
- h. Set the channel 2 + Input Coupling switch to GND and the channel 2 — Input Coupling switch to DC.
- i. Change the channel 2 + Input Coupling switch back and forth from GND to DC.
- j. CHECK—Displayed waveform; there should be very little if any effect on the waveform as part i of this step is accomplished.
- k. ADJUST—C416, see Fig. 6-11, for minimum waveform change during completion of part j.
- l. Disconnect the square-wave generator, 5 ns coaxial cable, GR to BNC male adapter and 5× BNC attenuator.

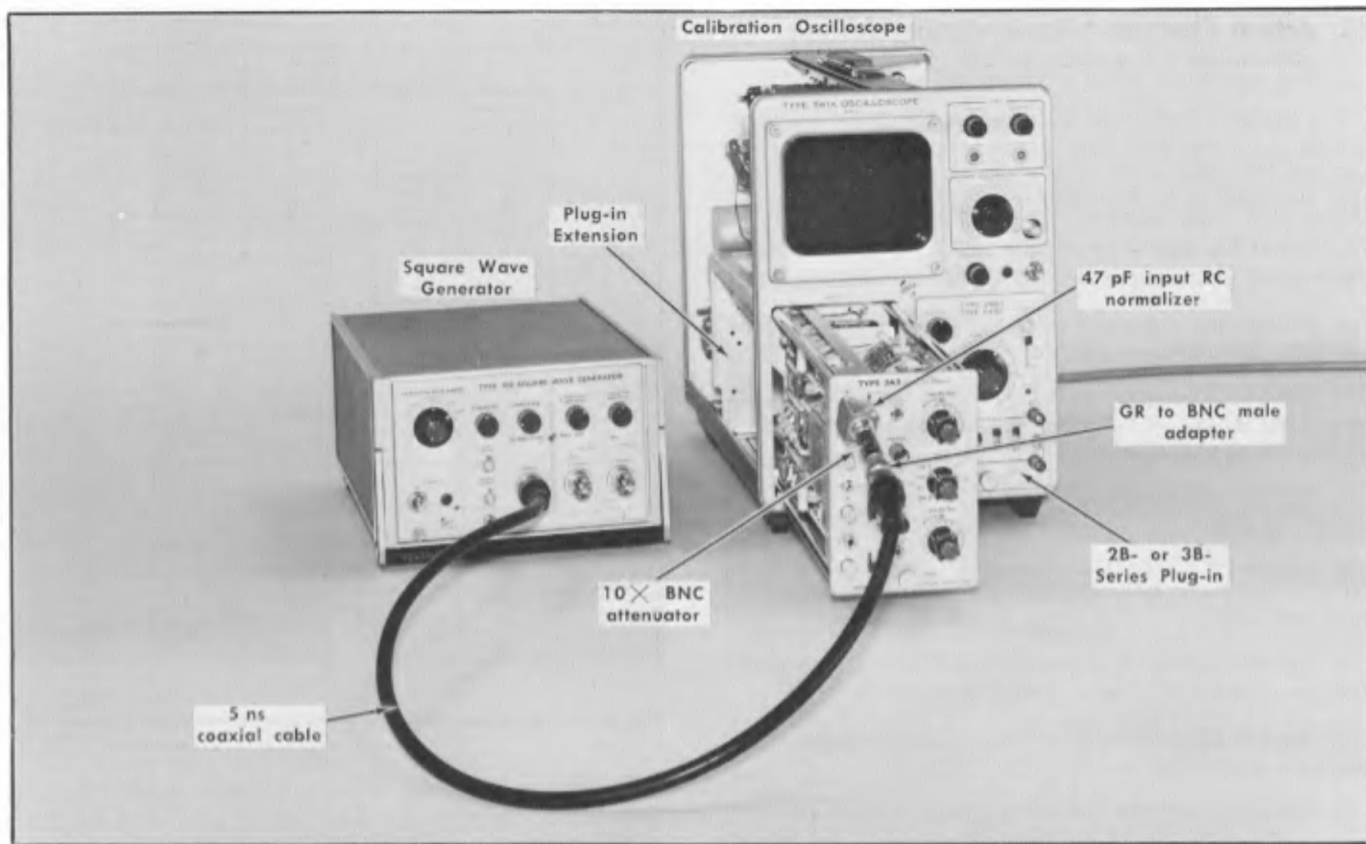


Fig. 6-12. Initial test equipment setup for steps 22 and 23.

<b>Type 3A3</b>		Astigmatism	Adjust for a well defined display
VOLTS/DIV (both channels)	10 mV	Alignment	As desired
VARIABLE (VOLTS/DIV) (both channels)	CAL	Calibrator	Off
STEP ATTEN BALANCE (both channels)	As is	Power	On
<b>POSITION</b> (both channels)	<b>Midrange</b>	Scale Illum	As desired
+ Input Coupling (channel 1)	DC	<b>2B- or 3B-Series Plug-In</b>	
+ Input Coupling (channel 2)	GND	Calibration	Adjust as per instruction manual procedure
- Input Coupling (both channels)	GND	Position	Midrange
<b>MODE</b>	<b>CH 1</b>	Mode	Normal
TRIGGER	COMP	Time/Div	0.5 ms
BANDWIDTH	500 kHz	Variable (Time/Div)	Calibrated
GAIN	As is	5x Mag	Off
<b>Calibration Oscilloscope</b>		Stability	Adjust as per instruction manual procedure
Intensity	As desired	Source	Internal
Focus	Adjust for a well defined display	Coupling	AC slow
		Slope	+
		Level	Adjust for stable display



## 22. Adjust Channel 1 Input Capacitance and Attenuator Compensation

- a. Test equipment setup is shown in Fig. 6-12.
- b. Connect a 1 kHz, high amplitude square-wave signal from a square-wave generator via a 5 ns coaxial cable, a GR to BNC male adapter, a 10× BNC attenuator and a 47 pF input RC normalizer to the Type 3A3 channel 1 + Input connector.
- c. Adjust the output signal amplitude of the square-wave generator to obtain a display about 5 major divisions in amplitude.
- d. CHECK—Displayed waveform; should appear similar to the waveform shown in Fig. 6-13.
- e. ADJUST—See Table 6-3 and Fig. 6-14 for appropriate component number and location to be adjusted for a square-wave display having an optimum front corner and minimum tilt (two separate adjustments in most VOLTS/DIV switch positions), see Fig. 6-13.
- f. Set the Type 3A3 channel 1 VOLTS/DIV switch to the next position listed in Table 6-3.
- g. Repeat parts c through f of this step until Table 6-3 is completed for channel 1 + Input connector.
- h. Disconnect the input square-wave signal from the channel 1 + Input connector and connect it to the channel 1 — Input connector. Re-insert the 10× BNC attenuator between the GR to BNC male adapter and the 47 pF input RC normalizer.
- i. Set the channel 1 VOLTS/DIV switch to 10 mV, channel 1 — Input Coupling switch to GND and the channel 1 — Input Coupling switch to DC.
- j. Adjust the output signal amplitude of the square-wave generator to obtain a display about 5 major divisions in amplitude.
- k. CHECK—Displayed waveform; should appear similar to the waveform shown in Fig. 6-13.
- l. ADJUST—See Table 6-3 and Fig 6-14 for appropriate component numbers and locations which should be adjusted for a square-wave display having an optimum front corner and minimum tilt; see Fig 6-13.
- m. Set the Type 3A3 channel 1 VOLTS/DIV switch to the next position listed in Table 6-3.
- n. Repeat parts j through m of this step until Table 6-3 is completed for channel 1 — Input connector.
- o. The test equipment remains connected for step 23.

## 23. Adjust Channel 2 Input Capacitance and Attenuator Compensation

- a. Set the channel 2 + Input Coupling to DC and the MODE switch to CH 2.

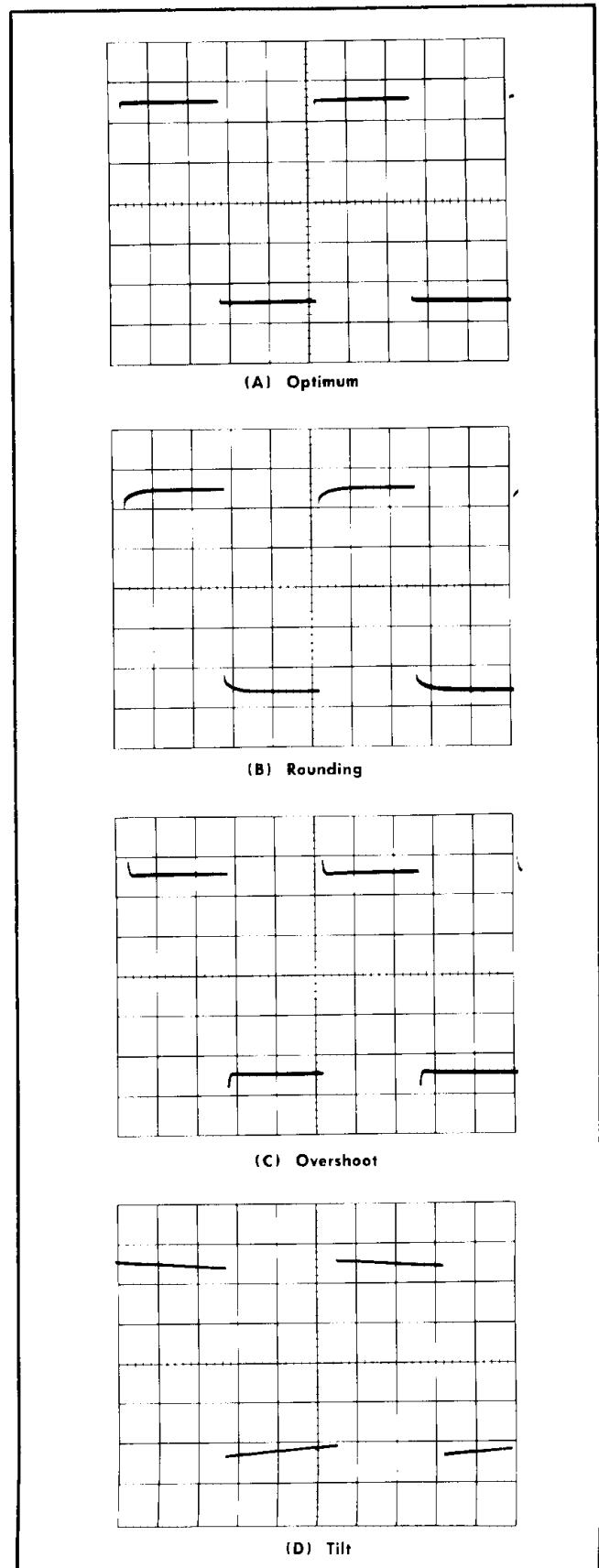


Fig. 6-13. Photographs of waveforms as it may appear when adjusting the input capacitance or attenuator compensation adjustments.

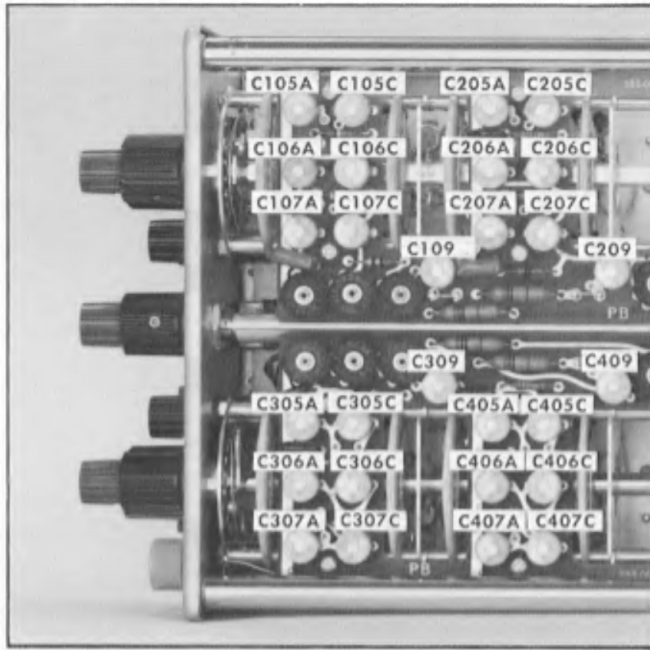


Fig. 6-14. Location of channels 1 and 2 input capacitance and attenuator compensation adjustments.

b. Disconnect the input square-wave signal from the Channel 1 — input connector and connect it to the channel 2 + Input connector. Re-insert the 10× BNC attenuator between the GR to BNC male adapter and the 47 pF input RC normalizer.

c. Adjust the output signal amplitude of the square-wave generator to obtain a display about 5 major divisions in amplitude.

d. CHECK—Displayed waveform; should appear similar to the waveform shown in Fig. 6-13.

e. ADJUST—See Table 6-3 and Fig 6-14 for appropriate component number and location to be adjusted for a square-wave display having an optimum front corner and minimum tilt. See Fig 6-13.

f. Set the Type 3A3 channel 2 VOLTS/DIV switch to the next position listed in Table 6-3.

g. Repeat parts c through f of this step until Table 6-3 is completed for channel 2 + input connector.

h. Disconnect the input square-wave signal from the channel 2 + input connector and connect it to the channel 2 — input connector. Re-insert the 10× BNC attenuator between the GR to BNC male adapter and the 47 pF input RC normalizer.

i. Set the channel 2 VOLTS/DIV switch to 10 mV, channel 2 + Input Coupling switch to GND and the channel 2 — Input Coupling switch to DC.

TABLE 6-3

Input Capacitance and Attenuator Compensation Adjustments

VOLTS/DIV Switch Setting for Channel being Checked	Channel 1				Channel 2			
	Adjust for Optimum Front Corner <sup>2</sup>		Adjust for Minimum Tilt <sup>3</sup>		Adjust for Optimum Front Corner <sup>2</sup>		Adjust for Minimum Tilt <sup>3</sup>	
	+ Input	— Input	+ Input	— Input	+ Input	— Input	+ Input	— Input
10 mV			C109	C209			C309	C409
20 mV	C105C	C205C	C105A	C205A	C305A	C405A	C305A	C405A
50 mV	Check	Check	Check	Check	Check	Check	Check	Check
0.1 V	Check	Check	Check	Check	Check	Check	Check	Check
0.2 V	C106C	C206C	C106A	C206A	C206C	C406C	C306A	C406A
0.5 V <sup>1</sup>	Check	Check	Check	Check	Check	Check	Check	Check
1 V	Check	Check	Check	Check	Check	Check	Check	Check
2 V	C107C	C207C	C107A	C207A	C307C	C407C	C307A	C407A
5 V	Check	Check	Check	Check	Check	Check	Check	Check
10 V	Check	Check	Check	Check	Check	Check	Check	Check

<sup>1</sup>Remove the 10× BNC attenuator for this and the following VOLTS/DIV switch positions.

<sup>2</sup>The stacked positions of the VOLTS/DIV switch (the 0.5, 5, 50 and 0.1, 1, 10 switch positions following a 0.2, 2, or 20 switch position) must also meet the requirements of the basic position (0.2, 2 or 20) switch position. If the waveform rounding, overshoot or tilt for a stacked position is in excess of 0.75 minor division, detune the basic position (staying within the ≤ 0.75 minor division requirement).

<sup>3</sup>First make the adjustment for an optimum front corner, then make the adjustment for minimum tilt.



j. Adjust the output signal amplitude of the square-wave generator to obtain a display about 5 major divisions in amplitude.

k. CHECK—Displayed waveform; should appear similar to the waveform shown in Fig 6-13.

l. ADJUST—See Table 6-3 and Fig 6-14 for appropriate component number and location to be adjusted for a square-wave display having an optimum front corner and minimum tilt; see Fig 6-13.

m. Set the Type 3A3 channel 2 VOLTS/DIV switch to the next position listed in Table 6-3.

n. Repeat parts k through m of this step until Table 6-3 is completed for channel 2 — input connector.

o. Disconnect the square-wave generator, 5 ns coaxial cable GR to BNC male adapter, and 47 pF input RC normalizer.

**NOTES**

---

---

---

---

---

---

---

---

---

---

---

---

---

---

---

---

---

---

---

---

---

---

---

---

---

---

---

---

---

---

---

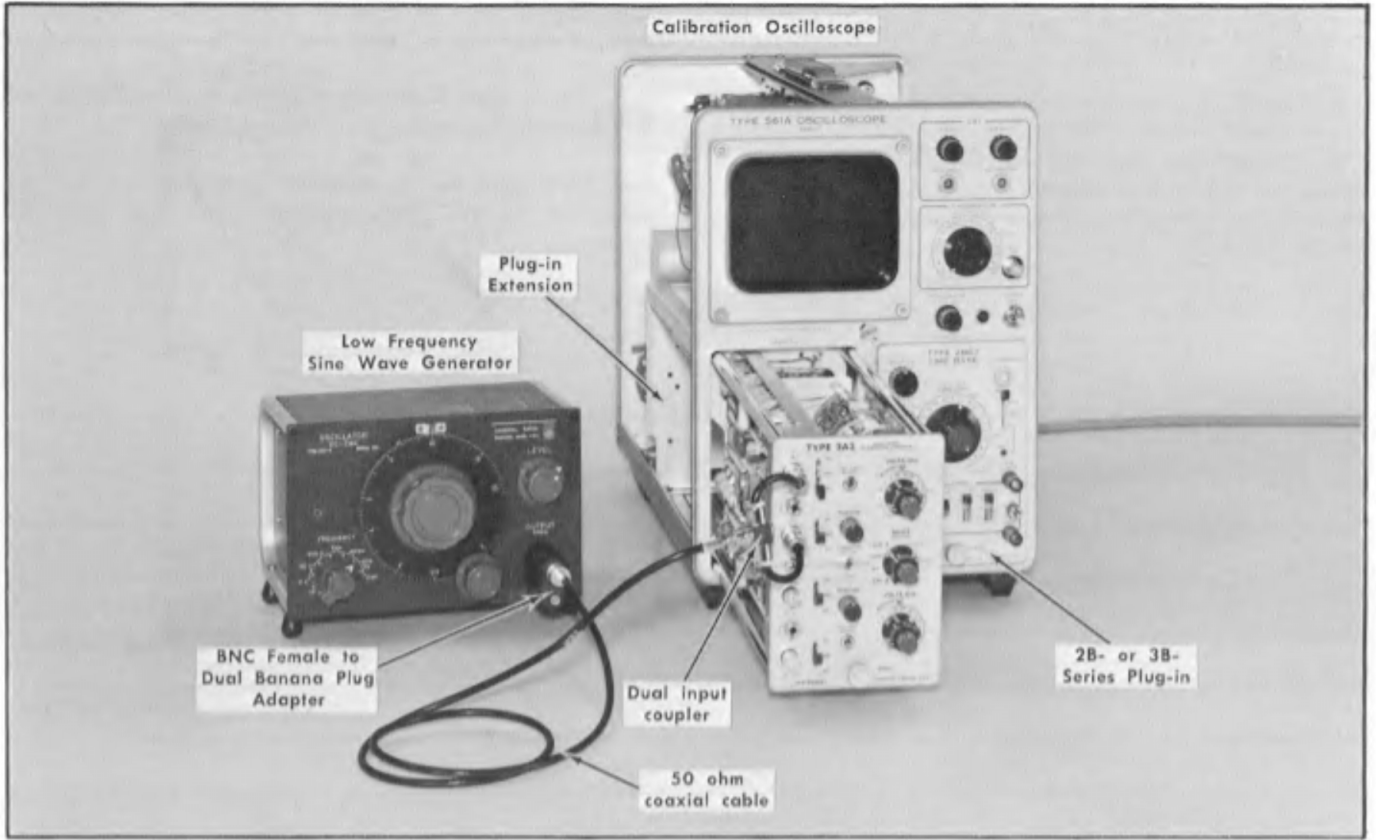


Fig. 6-15. Initial test equipment setup for steps 24 through 27.

<b>Type 3A3</b>		Astigmatism	Adjust for a well defined display
<b>VOLTS/DIV</b> (both channels)	<b>2 V</b>	Alignment	As desired
<b>VARIABLE (VOLTS/DIV)</b> (both channels)	<b>CAL</b>	Calibrator	Off
<b>STEP ATTEN BALANCE</b> (both channels)	<b>As is</b>	Power	On
<b>POSITION</b> (both channels)	<b>Midrange</b>	Scale Illum	As desired
<b>+ Input Coupling</b> (channel 1)	<b>DC</b>	<b>2B or 3B-Series Plug-In</b>	
<b>+ Input Coupling</b> (channel 2)	<b>GND</b>	Calibration	Adjust as per instruction manual procedure
<b>- Input Coupling</b> (both channels)	<b>GND</b>	Position	Midrange
<b>MODE</b>	<b>CH 1</b>	Mode	Normal
<b>TRIGGER</b>	<b>COMP</b>	Time/Div	1 ms
<b>BANDWIDTH</b>	<b>500 kHz</b>	Variable (Time/Div)	Calibrated
<b>GAIN</b>	<b>As is</b>	5X Mag	Off
<b>Calibration Oscilloscope</b>		Stability	Adjust as per instruction manual procedure
Intensity	As desired	Source	Internal
Focus	Adjust for a well defined display	Coupling	AC Slow
		Slope	+
		<b>Level</b>	<b>Free run</b>

## 24. Adjust Channel 1 High Frequency Differential Balance Capacitors

- Test equipment setup is shown in Fig. 6-15.
- Connect one end of a dual-input coupler to the Type 3A3 Channel 1 + Input connector and the other end to the channel 1 — input connector.
- Connect a 10 V, 100 kHz sine wave signal from a low frequency sine-wave generator via a BNC female to dual banana plug adapter and a 50 ohm coaxial cable to the center connector of the dual-input coupler.
- Adjust the sine-wave signal amplitude to obtain a display of 5 major divisions.
- Set the channel 1 — Input Coupling switch to DC and the channel 1 VOLTS/DIV switch to 0.1 mV.
- Use the channel 1 POSITION control to position the display to a convenient measuring point on the graticule.
- CHECK—Display amplitude; should be 2 major divisions or less.
- ADJUST—C115, see Fig. 6-16 for minimum display amplitude; then adjust C214 for minimum display amplitude. Alternately repeat the adjustments in this part until the smallest possible display amplitude is obtained. Reduce the sine-wave signal frequency to 1 kHz before proceeding to part i of this step.
- ADJUST—C212 for minimum display amplitude. If the display amplitude is still greater than 2 major divisions, repeat part h and this part of the step until the display amplitude is 2 major divisions or less. Increase the sine-wave signal frequency to 100 kHz before repeating h of this step.
- The test equipment remains connected for step 25.

## 25. Adjust Channel 2 High Frequency Differential Balance Capacitors

- Set the channel 2 — Input Coupling switch to DC and the MODE switch to CH 2.
- Disconnect the dual-input coupler from channel 1 input connectors and connect it to the channel 2 input connectors.
- Increase the sine-wave signal frequency to 100 kHz and adjust the sine-wave signal amplitude to obtain a display of 5 major divisions.
- Set the channel 2 — Input Coupling switch to DC and the channel 2 VOLTS/DIV switch to 0.1 mV.
- Use the channel 2 POSITION control to position the display to a convenient measuring point on the graticule.
- CHECK—Display amplitude; should be 2 major divisions or less.

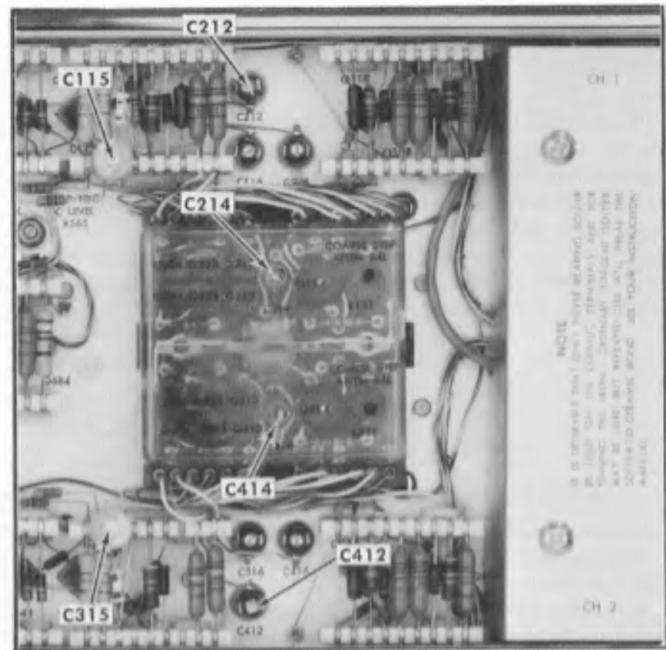


Fig. 6-16. Location of channels 1 and 2 high frequency differential balance adjustments.

- ADJUST—C315 (see Fig. 6-16), for minimum display amplitude; then adjust C414, for minimum display amplitude. Alternately repeat the adjustments in this part until the smallest possible display amplitude is obtained. Reduce the sine-wave signal frequency to 1 kHz before proceeding to part h of this step.
- ADJUST—C412 for minimum display amplitude. If the display amplitude is still greater than 2 major divisions, repeat part g and this part of the step until the display amplitude is 2 major divisions or less. Increase the sine-wave signal frequency to 100 kHz before repeating part of this step.
- The test equipment remains connected for step 26.

## 26. Adjust Channel 2 — Input Attenuator Compensation Capacitors

- Set the channel 2 VOLTS/DIV switch to 2 V and channel 2 — Input Coupling switch to GND.
- Adjust the sine-wave signal amplitude to obtain a display of 5 major divisions.
- Set the channel 2 — Input Coupling switch to DC and the channel 2 VOLTS/DIV switch to the setting called out in Table 6-4 for the adjustment being checked.
- Use the channel 2 POSITION control to position the display to a convenient measuring point on the graticule.

**Calibration—Type 3A3**

- e. CHECK—Display amplitude; should be equal to or less than the display amplitude called out in Table 6-4 for the VOLTS/DIV switch position being checked.
- f. ADJUST—See Table 6-4 and Fig 6-14 for the appropriate component number and location to be adjusted to reduce the display amplitude to or below the maximum amount shown in Table 6-4 for the VOLTS/DIV switch position being adjusted.
- g. Repeat parts c through f of this step until Table 6-4 is completed for channel 2.
- h. The test equipment remains connected for step 27.

**TABLE 6-4**

— Input Attenuator Compensation Adjustments

VOLTS/DIV Switch Setting for Channel being Checked	Channel 1 Adjustment	Channel 2 Adjustment	Maximum Display Amplitude in minor Divisions
20 mV	C205C	C405C	2.5
0.2 V	C206C	C406C	0.5
2 V	C207C	C407C	Normal trace width

**27. Adjust Channel 1 — Input Attenuator Compensation Capacitors ①**

- a. Set the channel 1 VOLTS/DIV switch to 2 V, channel 1 — Input Coupling switch to GND and the MODE switch to CH 1.
- b. Disconnect the dual-input coupler from channel 2 input connectors, and connect it to the channel 1 input connectors.
- c. Adjust the sine wave signal amplitude to obtain a display of 5 major divisions.
- d. Set the channel 1 — Input Coupling switch to DC and the channel 1 VOLTS/DIV switch to the setting called out in Table 6-4 for the adjustment being checked.
- e. Use the channel 1 POSITION control to position the display to a convenient measuring point on the graticule.
- f. CHECK—Display amplitude; should be equal to or less than the display amplitude called out in Table 6-4 for the VOLTS/DIV switch position being checked.
- g. ADJUST—See Table 6-4 and Fig. 6-14 for the appropriate component number and location to be adjusted to reduce the display amplitude to or below the maximum amount shown in Table 6-4 for the VOLTS/DIV switch position being adjusted.
- h. Repeat parts d through g of this step until Table 6-4 is completed for channel 1.
- i. Disconnect the low frequency sine-wave generator, BNC female to dual banana plug adapter, 50 ohm coaxial cable and the dual-input coupler.

**NOTES**

---

---

---

---

---

---

---

---

---

---

---

---

---

---

---

---

---

---

---

---

---

---

---

---

---

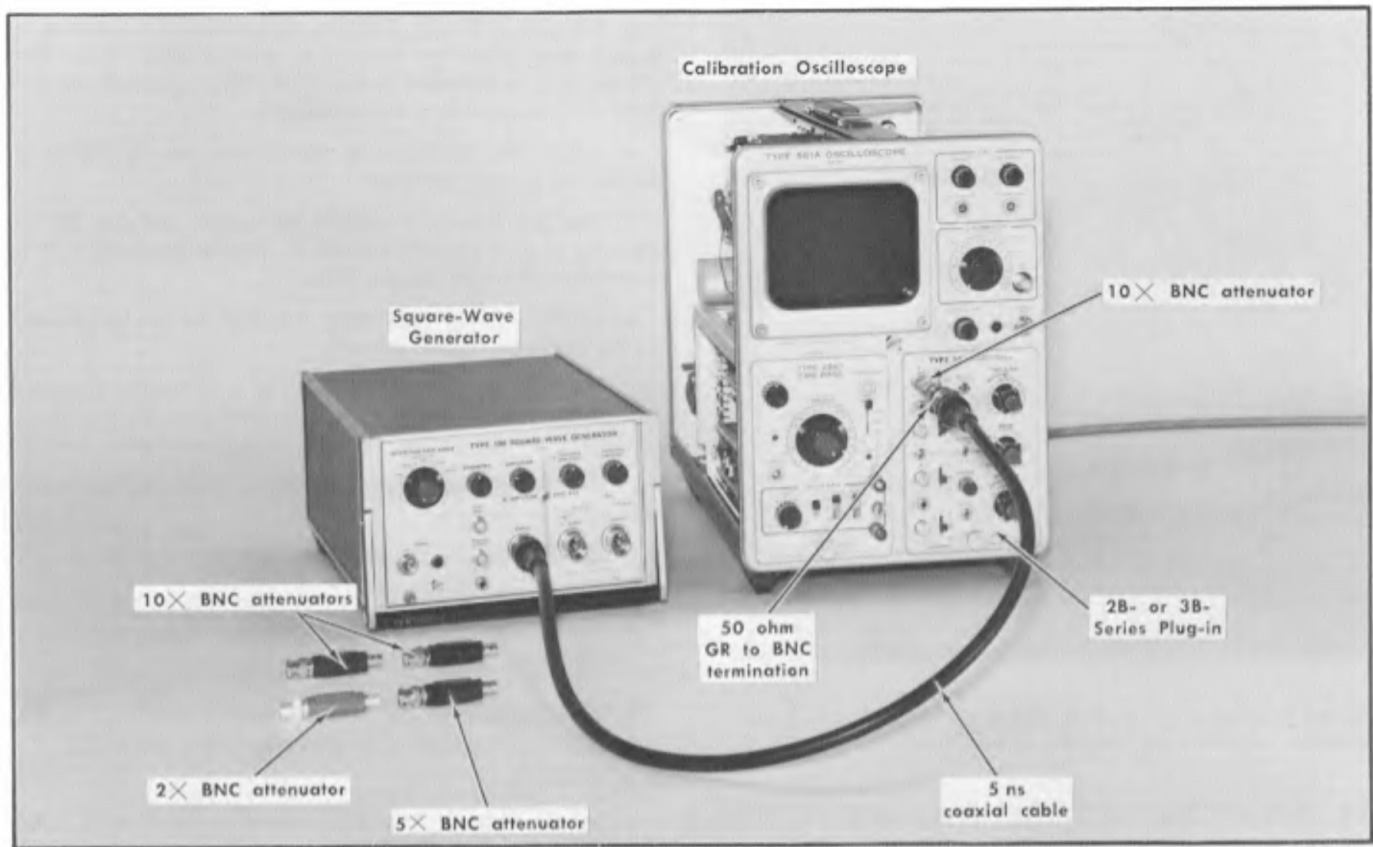


Fig. 6-17. Initial test equipment setup for steps 28 and 29.

<b>Type 3A3</b>		Astigmatism	Adjust for a well defined display
<b>VOLTS/DIV</b> (both channels)	10 mV	Alignment	As desired
<b>VARIABLE (VOLTS/DIV)</b> (both channels)	CAL	Calibrator	Off
<b>STEP ATTEN BALANCE</b> (both channels)	As is	Power	On
<b>POSITION</b> (both channels)	Midrange	Scale Illum	As desired
+ Input Coupling (channel 1)	DC	<b>2B- or 3B-Series Plug-In</b>	
+ Input Coupling (channel 2)	GND	Calibration	Adjust as per instruction manual procedure
- Input Coupling (both channels)	GND	Position	Midrange
MODE	CH 1	Mode	Normal
TRIGGER	COMP	<b>Time/Div</b>	5 $\mu$ S
BANDWIDTH	500 kHz	Variable (Time/Div)	Calibrated
GAIN	As is	5x Mag	Off
<b>Calibration Oscilloscope</b>		Stability	Adjust as per instruction manual procedure
Intensity	As desired	Source	Internal
Focus	Adjust for a well defined display	Coupling	AC slow
		Slope	+
		<b>Level</b>	<b>Automatic</b>

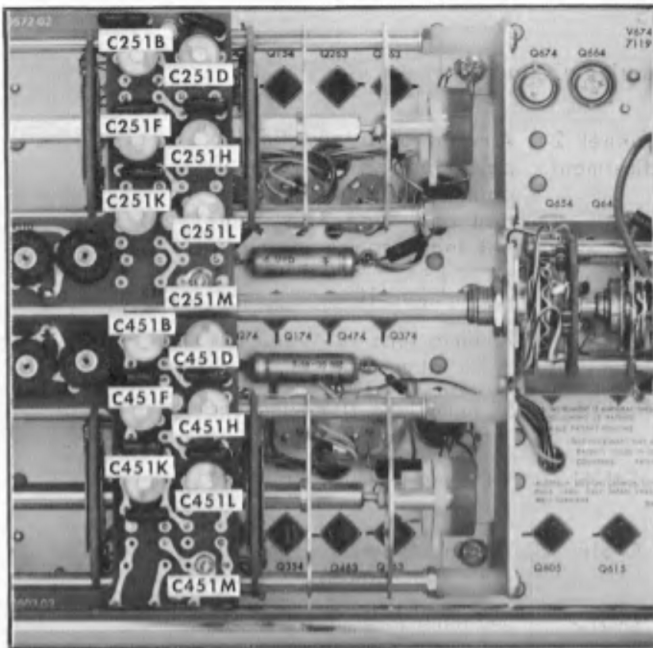


Fig. 6-18. Location of 10 mV through 0.1 mV high frequency compensation capacitors for channels 1 and 2.

### 28. Adjust Channel 1 High Frequency Compensation Capacitors

**NOTE**

When two Type 3A3 Plug-In units have each had the high frequency compensation capacitors of both channels adjusted using this procedure, there will generally be less than 2° of phase difference at 100 kHz between any two channels. If this degree of phase difference is considered excessive for a particular phase comparison application, refer to Section 2 Operating Instructions for a method of balancing the high frequency compensation of the channels in one unit with the compensation of the channels in the other unit. This step cannot be performed if a Type 565 or RM565 Oscilloscope is being used as the calibration oscilloscope.

- a. Test equipment setup is shown in Fig. 6-17.
- b. Remove the Type 3A3 and the plug-in extension from the vertical plug-in compartment, and the 2B- or 3B-series plug-in from the horizontal plug-in compartment of the calibration oscilloscope.
- c. Install the Type 3A3 into the horizontal plug-in compartment of the calibration oscilloscope without the plug-in extension, then install the 2B- or 3B-series plug-in into the vertical plug-in compartment.

- d. Connect a 80 mV, 100 kHz square-wave signal from a square-wave generator via a 5 ns coaxial cable, a 50 ohm GR to BNC termination and a 10× BNC attenuator to the Type 3A3 channel 1 + input connector.

- e. Adjust the square-wave signal amplitude to obtain a display of 8 major divisions.

- f. Use the channel 1 POSITION control and the 2B- or 3B-series plug-in position control to position the display to a convenient place on the graticule.

- g. CHECK—Lower right-hand corner of the display; should be an optimum square corner.

- h. ADJUST—See Table 6-5 and Fig. 6-18 for the component number and location to be adjusted to make the lower right-hand corner of the display an optimum square corner.

- i. Set the channel 1 VOLTS/DIV switch to the next position listed in Table 6-5.

- j. Repeat parts e through i of this step until Table 6-5 has been completed for channel 1.

- k. The test equipment remains connected for step 29.

### 29. Adjust Channel 2 High Frequency Compensation Capacitors (See step 28 NOTE).

- a. Set the channel 2 + Input Coupling switch to DC and the MODE switch to CH 2.

- b. Disconnect the square-wave signal from the channel 1 + input connector and connect it to the channel 2 + input connector.

- c. Remove all but one of the 10× BNC attenuators from between the 50 ohm GR to BNC termination and the channel 2 + input connector.

- d. Adjust the square-wave signal amplitude to obtain a display of 8 major divisions.

- e. Use the channel 2 POSITION control and the 2B- or 3B-series plug-in position control to position the display to a convenient graticule location.

- f. CHECK—Lower right-hand corner of the display; should be an optimum square corner.

- g. ADJUST—See Table 6-5 and Fig. 6-18 for the component number and location to be adjusted to make the lower right-hand corner of the display an optimum square corner.

- h. Set the channel 2 VOLTS/DIV switch to the next position listed in Table 6-5.

- i. Repeat parts d through h of this step until Table 6-5 has been completed for channel 2.

- j. Disconnect the square-wave generator, 5 ns coaxial cable, 50 ohm GR to BNC termination and the three 10× BNC terminations.

TABLE 6-5

## High Frequency Compensation Capacitors

VOLTS/DIV Switch Setting for Channel being checked	Channel 1 Adjustment	Channel 2 Adjustment	Amount of attenuation to be connected between 50 ohm GR to BNC termina- tion and Type 3A3 chan- nel input connector
10 mV	C251M	C451M	10 times (one 10× attenuator)
5 mV	C251L	C451L	20 times (one 10× and one 2× attenuator)
2 mV	C251K	C451K	50 times (one 10× and one 5× attenuator)
1 mV	C251H	C451H	100 times (two 10× attenua- tors)
0.5 mV	C251F	C451F	200 times (two 10× and one 2× attenuator)
0.2 mV	C251D	C451D	500 times (two 10× and one 5× attenuator)
0.1 mV	C251B	C451B	1000 times (three 10× at- tenuators)

## NOTES



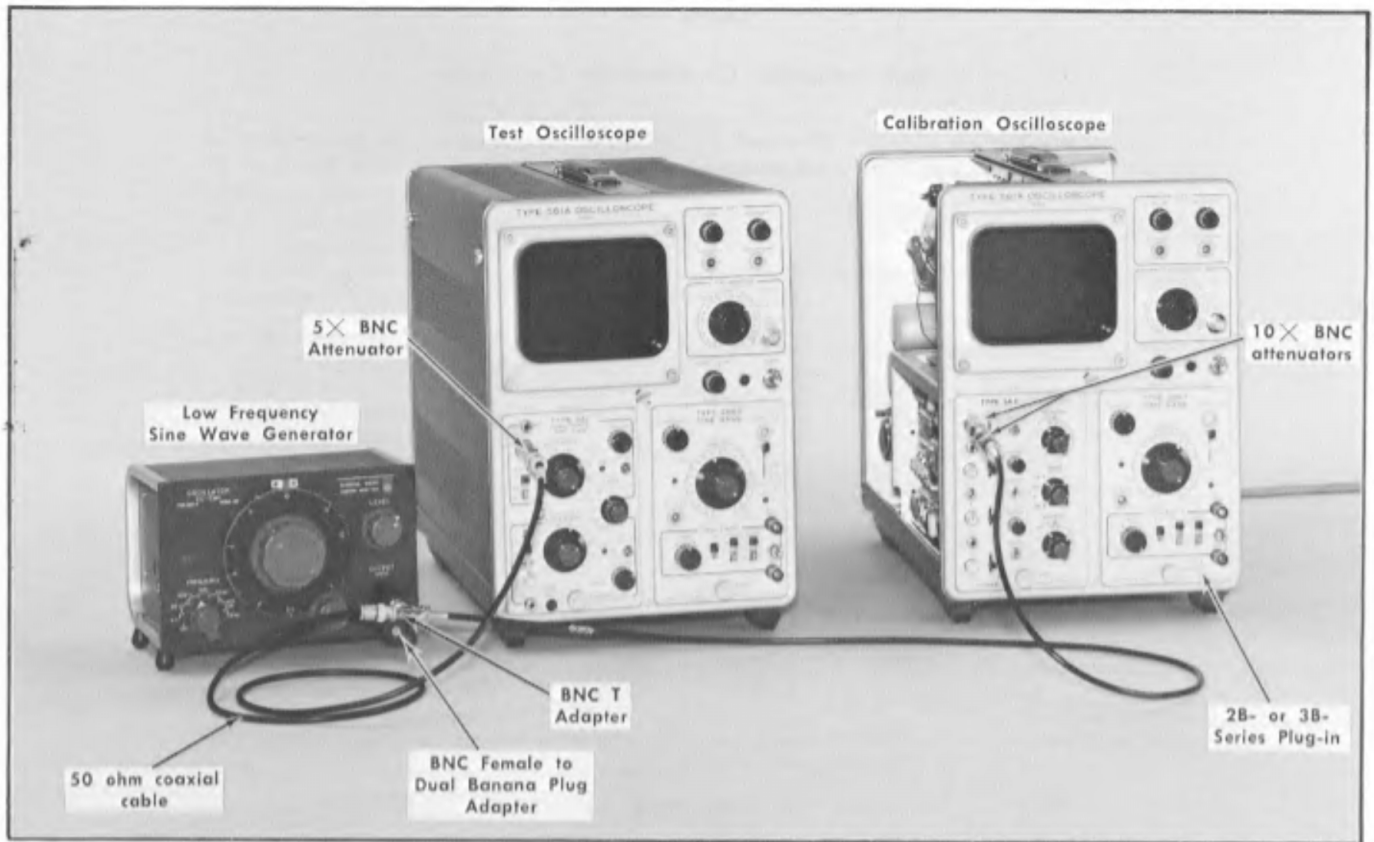


Fig. 6-19. Initial test equipment setup for steps 30 through 35.

	<b>Type 3A3</b>	Astigmatism	Adjust for a well defined display
VOLTS/DIV (both channels)	0.1 mV	Alignment	As desired
VARIABLE (VOLTS/DIV) (both channels)	CAL	Calibrator	Off
STEP ATTEN BALANCE (both channels)	As is	Power	On
<b>POSITION (both channels)</b>	<b>Midrange</b>	Scale Illum	As desired
+ Input Coupling (channel 1)	DC		
<b>+ Input Coupling (channel 2)</b>	<b>GND</b>	<b>2B- or 3B-Series Plug-in</b>	
- Input Coupling (both channels)	GND	Calibration	Adjust as per instruction manual procedure
<b>MODE</b>	<b>CH 1</b>	Position	Midrange
TRIGGER	COMP	Mode	Normal
BANDWIDTH	500 kHz	<b>Time/Div</b>	<b>0.5 ms</b>
GAIN	As is	Variable (Time/Div)	Calibrated
		5x Mag	Off
		Stability	Adjust as per instruction manual procedure
		Source	Internal
<b>Calibration Oscilloscope</b>		Coupling	AC slow
Intensity	As desired	Slope	+
Focus	Adjust for a well defined display	<b>Level</b>	<b>Free run</b>



### 30. Check Channel 1 Upper 500 kHz Bandwidth Frequency Response

- a. Test equipment setup is shown in Fig. 6-19.
- b. Remove the Type 3A3 from the horizontal plug-in compartment, and the 2B- or 3B-series plug-in from the vertical plug-in compartment of the calibration oscilloscope.
- c. Install the Type 3A3 into the vertical plug-in compartment, and the 2B- or 3B-series plug-in into the horizontal plug-in compartment of the calibration oscilloscope.
- d. Connect 1 kHz sine wave signal about 4 major divisions high from a low frequency sine wave generator via a BNC female to dual banana plug adapter, BNC T adapter, 50 ohm coaxial cable and two 10× BNC attenuators to the Type 3A3 channel 1 + input connector.
- e. Connect a second 50 ohm coaxial cable from the low frequency sine-wave generator signal output connector to the vertical input connector of the test oscilloscope via a 5× BNC attenuator.
- f. Set the test oscilloscope for a vertical deflection factor that produces a display of about 1 or more major divisions, AC coupled at a sweep rate of 0.5 ms/division with internal triggering.
- g. Adjust the sine-wave signal amplitude to obtain a display of exactly 4 major divisions.
- h. Note the exact test oscilloscope displayed amplitude.
- i. Increase the frequency of the low frequency sine-wave generator until the display amplitude on the calibration oscilloscope falls to 2.8 major divisions. The sine-wave output signal amplitude should be adjusted as necessary to keep the display amplitude of the test oscilloscope constant at the amplitude noted in part h of this step.
- j. CHECK—Sine-wave frequency; 500 kHz or higher.
- k. Repeat parts d through j of this step for each switch position of the channel 1 VOLTS/DIV switch for which sufficient input signal amplitude is available, removing the attenuators as needed to obtain the 4 major division display as described in part g of this step. The test oscilloscope volts/division switch will require changing as the sine-wave signal amplitude is increased.
- l. The test equipment remains connected for step 31.

### 31. Check Channel 2 Upper 500 kHz Bandwidth Frequency Response

- a. Set the channel 1 + Input Coupling switch to GND, channel 2 + Input Coupling switch to DC and the MODE switch to CH 2.
- b. Remove the sine-wave signal from channel 1 + input connector and connect the 1 kHz sine-wave signal about 4 major divisions high from a low frequency sine-wave generator, 50 ohm coaxial cable and two 10× attenuators to the Type 3A3 channel 2 + input connector.

- c. Connect a second 50 ohm coaxial cable from the low frequency sine-wave generator signal output connector to the vertical input connector of the test oscilloscope via a 5× BNC attenuator.

- d. Set the test oscilloscope for a vertical deflection factor that produces a display of about 1 or more major divisions, AC coupled at a sweep rate of 0.5 ms/division with internal triggering.

- e. Adjust the sine-wave signal amplitude to obtain a display of exactly 4 major divisions.

- f. Note the exact test oscilloscope displayed amplitude.

- g. Increase the frequency of the sine-wave generator until the display amplitude on the calibration oscilloscope falls to 2.8 major divisions. The sine-wave output signal amplitude should be adjusted as necessary to keep the display amplitude of the test oscilloscope constant.

- h. CHECK—Sine-wave frequency; 500 kHz or higher.

- i. Repeat parts b through h of this step for each switch position of the channel 2 VOLTS/DIV switch for which sufficient input signal amplitude is available, removing the attenuators as needed to obtain the 4 major division display as described in part e of this step. The test oscilloscope volts/division switch will require changing as the sine-wave signal amplitude is increased.

- j. The test equipment remains connected for step 32.

### 32. Check Channel 2 Upper 5 kHz Bandwidth Frequency Response

- a. Set the Type 3A3 VOLTS/DIV switch of both channels to 10 mV and the BANDWIDTH switch to 5 kHz.
- b. Connect 1 kHz sine-wave signal about 4 major divisions high from a low frequency sine-wave generator via a BNC female to dual banana plug adapter, BNC T adapter and a 50 ohm coaxial cable to the Type 3A3 channel 2 + input connector.
- c. Connect a second 50 ohm coaxial cable from the sine-wave generator signal output connector to the vertical input connector of the test oscilloscope via a 5× BNC attenuator.
- d. Set the test oscilloscope for a vertical deflection factor that produces a display of about 4 or more major divisions, AC coupled at a sweep rate of 0.5 ms/division with internal triggering.
- e. Adjust the sine-wave signal amplitude to obtain a display of exactly 4 major divisions.
- f. Note the exact test oscilloscope displayed amplitude.
- g. Increase the frequency of the sine-wave generator until the display amplitude on the calibration oscilloscope falls to 2.8 major divisions. The sine-wave output signal amplitude should be adjusted as necessary to keep the display amplitude of the test oscilloscope constant.

## Calibration—Type 3A3

- h. CHECK—Sine-wave frequency; 5 kHz to 6.25 kHz.
- i. The test equipment remains connected for step 33.

### 33. Check Channel 1 Upper 5 kHz Bandwidth Frequency Response

a. Set the channel 2 + Input Coupling switch to GND, channel 1 + Input Coupling switch to DC and the MODE switch to CH 1.

b. Remove the sine-wave signal from channel 2 + input connector and connect the 4 major division 1 kHz sine-wave signal from the sine-wave generator via a BNC female to dual banana plug adapter, BNC T adapter and 50 ohm coaxial cable to the Type 3A3 channel 1 + input connector.

c. Connect a second 50 ohm coaxial cable from the sine-wave generator signal output connector to the vertical input connector of the test oscilloscope via a 5X BNC attenuator.

d. Set the test oscilloscope for a vertical deflection factor that produces a display of about 1 or more major divisions, AC coupled at a sweep rate of 0.5 ms/division with internal triggering.

e. Adjust the sine-wave signal amplitude to obtain a display of exactly 4 major divisions.

f. Note the exact test oscilloscope displayed amplitude.

g. Increase the frequency of the sine-wave generator until the display amplitude on the calibration oscilloscope falls to 2.8 major divisions. The sine-wave output signal amplitude should be adjusted as necessary to keep the display amplitude of the test oscilloscope constant.

h. CHECK—Sine-wave frequency; 5 kHz to 6.25 kHz.

i. The test equipment remains connected for step 34.

### 34. Check Channel 1 AC Low Frequency Response

a. Set the channel 1 and 2 VOLTS/DIV switches to 10 mV, channel 1 + Input Coupling switch to AC and the BANDWIDTH switch to 500 kHz. Set the 2B- or 3B-series plug-in time/division switch to 1 ms.

b. Disconnect the 50 ohm coaxial cable from the Type 3A3, and connect a 10X BNC attenuator and a 5X BNC attenuator in the signal path, then reconnect the 50 ohm cable to the last attenuator in the Type 3A3 signal path.

c. Connect 100 Hz sine-wave signal about 4 major divisions high from a low frequency sine-wave generator via a BNC female to dual banana plug adapter, BNC T adapter, 50 ohm coaxial cable, a 10X BNC attenuator and a 5X BNC attenuator to the Type 3A3 channel 1 + input connector.

d. Connect a second 50 ohm coaxial cable from the sine-wave generator signal output connector to the vertical input connector of the test oscilloscope via a 5X BNC attenuator.

e. Set the test oscilloscope for a vertical deflection factor that produces a display of about 1 or more major divisions, AC coupled at a sweep rate of 50 ms/division with internal triggering.

f. Adjust the sine-wave signal amplitude to obtain a Type 3A3 display of exactly 4 major divisions.

g. Note the exact test oscilloscope displayed amplitude.

h. Decrease the frequency of the sine-wave generator until the display amplitude on the calibrator oscilloscope falls to 2.8 major division. The sine-wave output signal amplitude should be adjusted as necessary to keep the display amplitude of the test oscilloscope constant.

i. CHECK—Sine-wave frequency; 2 Hz or lower.

j. Set the channel 1 + Input Coupling switch to GND and the channel 1 — Input Coupling switch to AC.

k. Connect 100 Hz sine-wave signal about 4 major divisions high from a low frequency sine-wave generator via a BNC female to dual banana plug adapter, BNC T adapter, 50 ohm coaxial cable, a 10X BNC attenuator and a 5X BNC attenuator to the Type 3A3 channel 1 — input connector.

l. Repeat parts d through i of this step for the channel 1 — input connector.

m. The test equipment remains connected for step 35.

### 35. Check Channel 2 AC Low Frequency Response

a. Set the channel 1 — Input Coupling switch to GND, channel 2 + Input Coupling switch to AC and the MODE switch to CH 2.

b. Remove the sine-wave signal from channel 1 — input connector and connect the 4 major division 100 Hz sine-wave signal from a low frequency sine-wave generator via a BNC female to dual banana plug adapter, BNC T adapter, 50 ohm coaxial cable, a 10X BNC attenuator and a 5X BNC attenuator to the Type 3A3 channel 2 + input connector.

c. Connect a second 50 ohm coaxial cable from the low frequency sine-wave generator signal output connector to the vertical connector of the test oscilloscope via a 5X BNC attenuator.

d. Set the test oscilloscope for a vertical deflection factor to give a display of about 1 or more major divisions, AC coupled at a sweep rate of 50 ms/division with internal triggering.



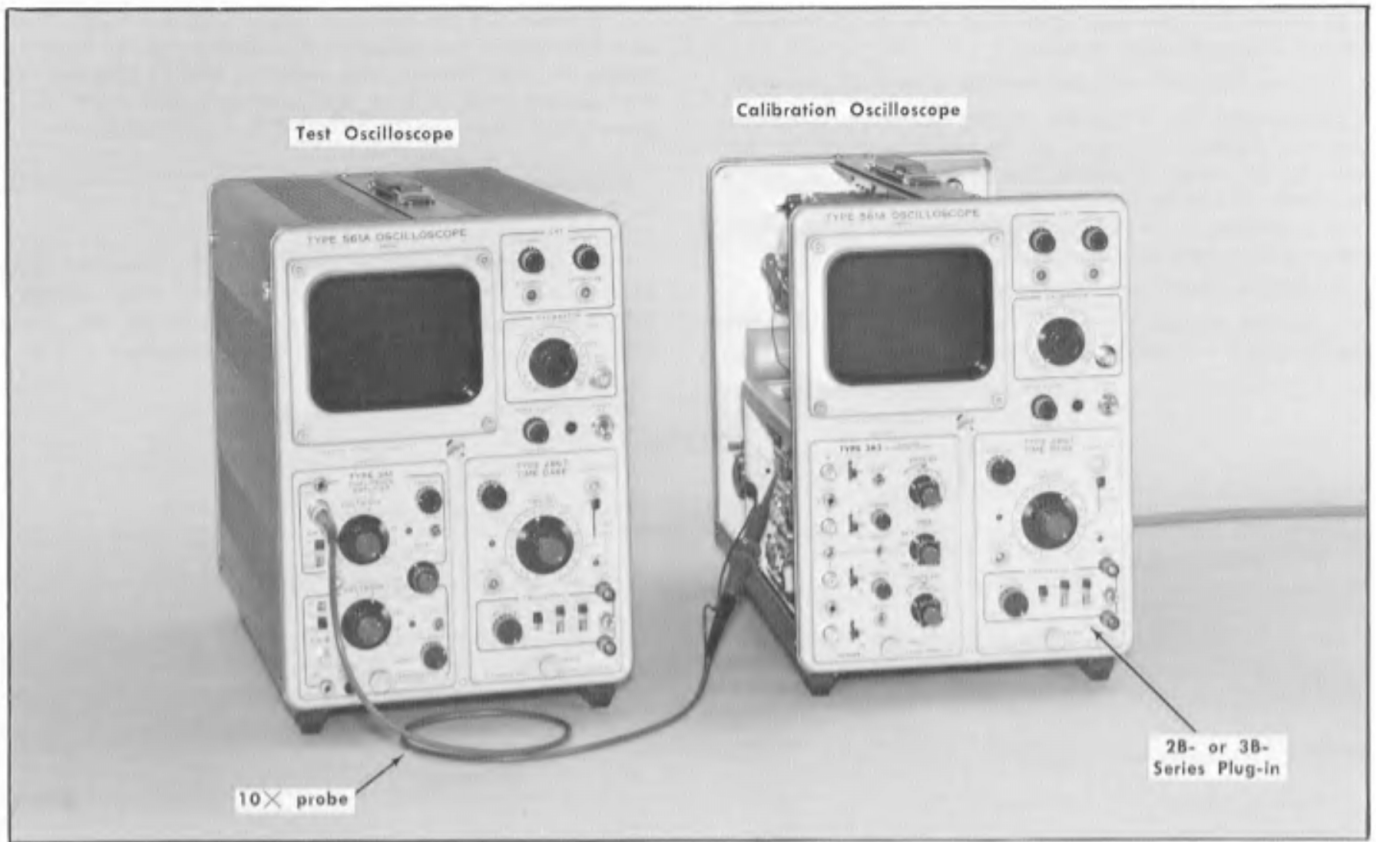


Fig. 6-20. Initial test equipment setup for step 36.

<b>Type 3A3</b>		Astigmatism	Adjust for a well defined display
VOLTS/DIV (both channels)	10 mV	Alignment	As desired
VARIABLE (VOLTS/DIV) (both channels)	CAL	Calibrator	Off
STEP ATTEN BALANCE (both channels)	As is	Power	On
<b>POSITION</b> (both channels)	<b>Midrange</b>	Scale Illum	As desired
+ INPUT COUPLING (both channels)	GND	<b>2B or 3B-Series Plug-In</b>	
- Input Coupling (both channels)	GND	Calibration	Adjust as per instruction manual procedure
<b>MODE</b>	<b>CH 1</b>	Position	Midrange
<b>TRIGGERING</b>	<b>CH 1</b>	Mode	Normal
BANDWIDTH	500 kHz	Time/Div	0.5 ms
GAIN	As is	Variable (Time/Div)	Calibrated
<b>Calibration Oscilloscope</b>		5x Mag	Off
Intensity	As desired	Stability	Adjust as per instruction manual procedure
Focus	Adjust for a well defined display	Source	Internal
		Coupling	AC slow
		Slope	+
		Level	Free run

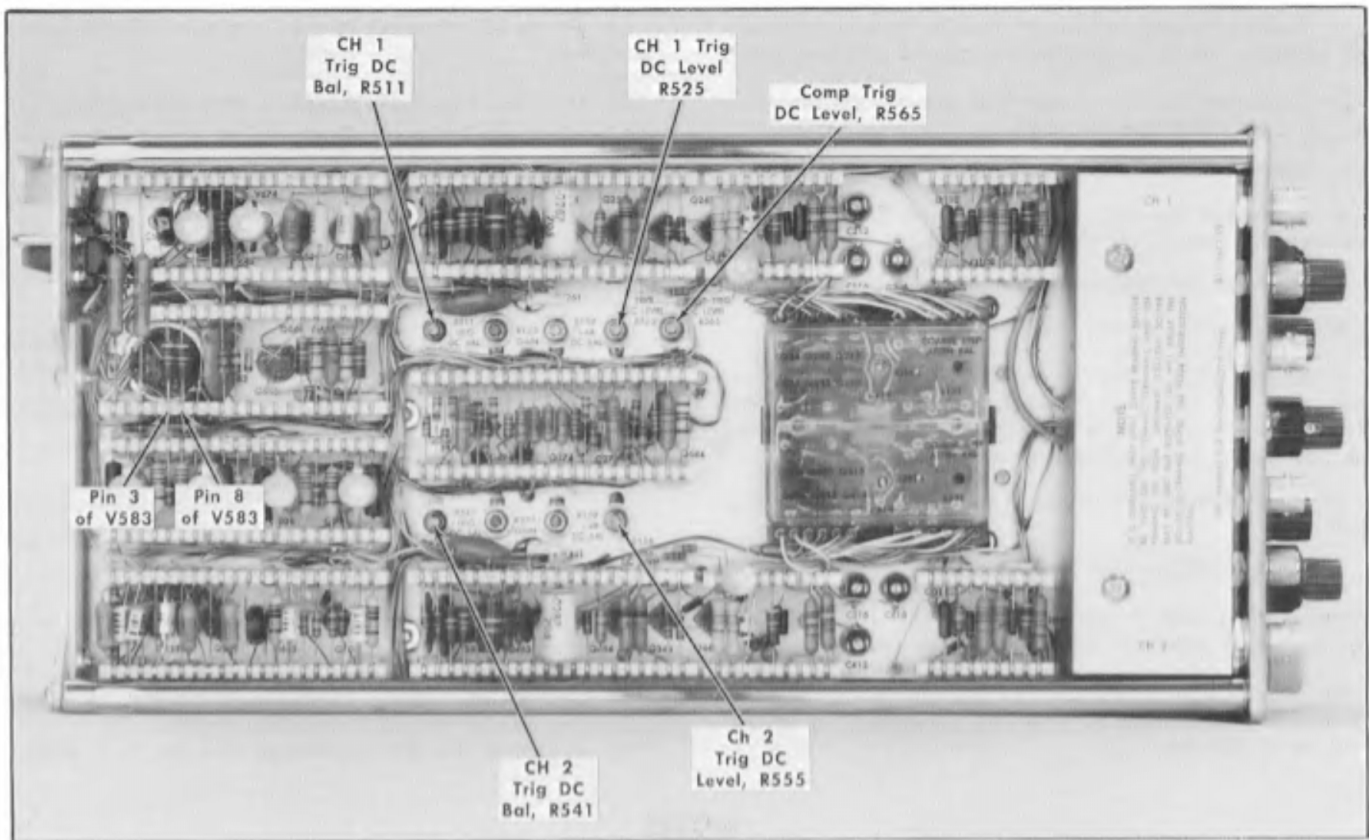


Fig. 6-21. Location of trigger amplifier test points and adjustments.

### 36. Adjust Trigger Amplifier Output DC Balance and DC Level ①

- a. Test equipment is shown in Fig. 6-20.
- b. Check the step attenuator balance adjustments for each channel and repeat them if necessary; the steps are step 2 for channel 1 and step 5 for channel 2.
- c. Connect a  $10\times$  probe from the test oscilloscope vertical input connector to a ground point.
- d. Set the test oscilloscope for a deflection factor of 10 mV/division, DC coupled at a sweep rate of 5 ms/division with a free running sweep.
- e. Position the test oscilloscope trace to the center horizontal graticule line. This graticule line is now at ground (0 volts) potential.
- f. Disconnect the  $10\times$  probe from ground and connect it to pin 8 of V583; see Fig. 6-21.
- g. Note the DC voltage level.
- h. Disconnect the  $10\times$  probe from pin 8 of V583 and connect it to pin 3 of V583; see Fig. 6-21.
  - i. Note the DC voltage level.
  - j. CHECK—DC voltage level; should be 0 volts between pins 3 and 8 of V583.
  - k. ADJUST—CH 1 Trig DC Bal R511, (see Fig. 6-21) for a zero potential between pins 3 and 8 of V583. Repeat parts f through j of this step until the check can be met.
  - l. Connect the  $10\times$  probe to pin 8 of V583, see Fig. 6-21.
  - m. CHECK—DC voltage level; should be 0 volts.
  - n. ADJUST—CH 1 Trig DC level, R525, (see Fig. 6-21) for a ground potential indication on the test oscilloscope.
  - o. Repeat part f through n of this step several times to remove any interaction between the adjustments in parts k and n of this step.
  - p. Set the MODE switch to CH 2 and the TRIGGER switch to CH 2.
  - q. Connect the  $10\times$  probe from the test oscilloscope vertical input connector to a ground point.

## Calibration—Type 3A3

- r. Position the test oscilloscope trace to the center horizontal graticule line to re-establish the ground reference point.
- s. Disconnect the 10X probe from ground and connect it to pin 8 of V583; see Fig. 6-22.
- t. Note the DC voltage level.
- u. Disconnect the 10X probe from pin 8 of V583 and connect it to pin 3 of V583; see Fig. 6-21.
- v. Note the DC voltage level.
- w. CHECK—DC voltage level; should be 0 volts.
- x. ADJUST—CH 2 Trig DC Bal R541; (see Fig. 6-21) for a zero potential indication between pins 3 and 8 of V583. Repeat parts s through w of this step until the check can be met on the test oscilloscope.
- y. Connect the 10X probe to pin 8 of V583. See Fig. 6-21.
- z. CHECK—DC voltage level; should be 0 volts.
- aa. ADJUST—CH 2 Trig DC Level, R555, (see Fig. 6-21) for a ground potential indication on the test oscilloscope.
- ab. Repeat parts s through z of this step several times to remove any interaction between the adjustments in parts x and aa of this step.
- ac. Set the MODE switch to CH 1 and the TRIGGER switch to COMP.
- ad. With the Type 3A3 channel 1 POSITION control, set the trace to the electrical center of the calibration oscilloscope. Electrical center is the position of the trace when the vertical CRT deflection plates have been externally shorted together.
- ae. Connect the 10X probe from the test oscilloscope vertical input connector to a ground point.
- af. Position the test oscilloscope trace to the center horizontal graticule to re-establish the ground reference point.
- ag. Disconnect the 10X probe from ground and connect it to pin 3 of V583, see Fig. 6-21.
- ah. CHECK—DC voltage level; should be 0 volts.
- ai. ADJUST—Comp Trig DC Level, R565, (see Fig. 6-21) for a ground potential indication on the test oscilloscope.
- aj. Disconnect the 10X probe from pin 3 of V583 and connect it to pin 8 of V583; see Fig. 6-21.
- ak. CHECK—DC voltage level; should be 0 volts.
- al. Disconnect the test oscilloscope and the 10X probe.

## NOTES

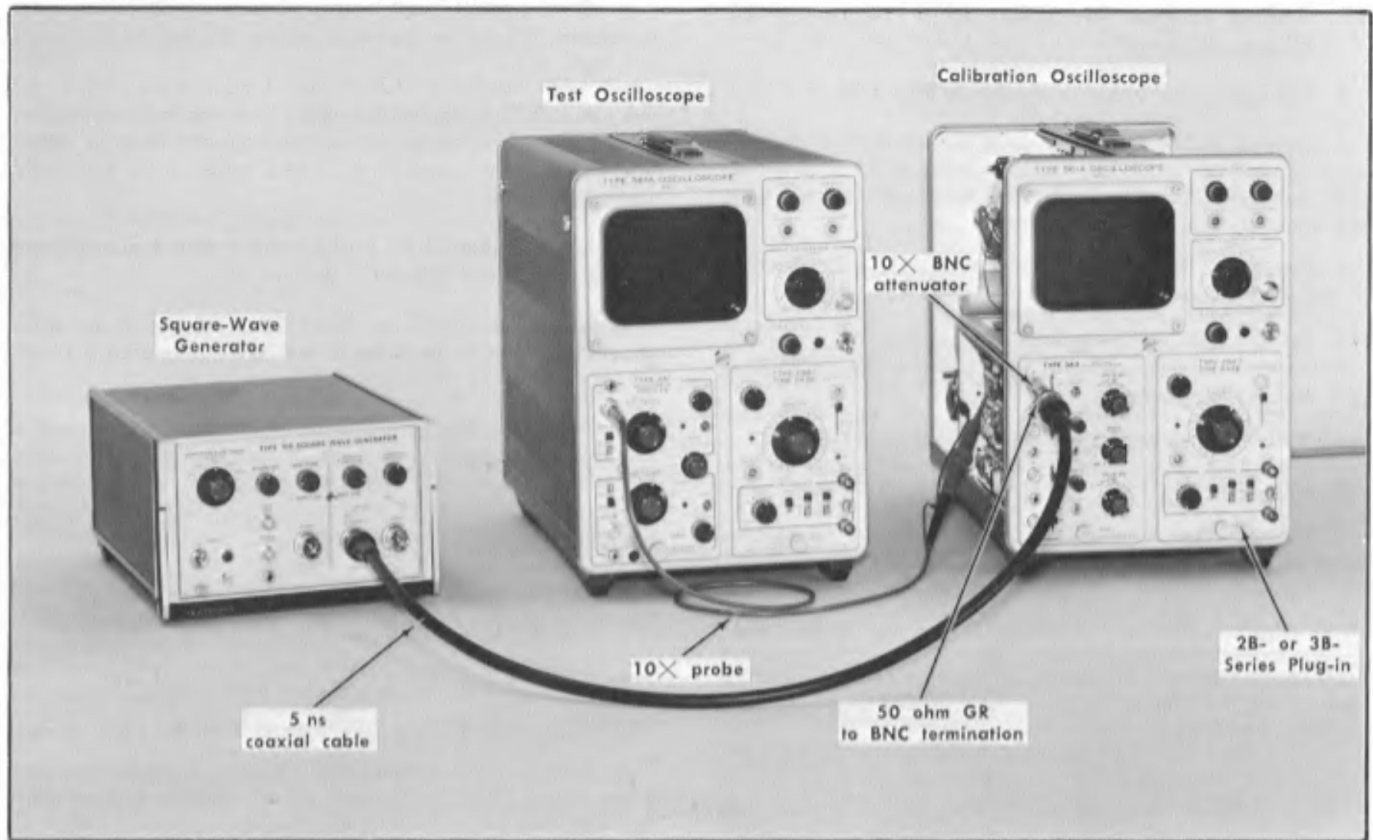


Fig. 6-22. Initial test equipment setup for steps 37 through 39.

<b>Type 3A3</b>		Astigmatism	Adjust for a well defined display
VOLTS/DIV (both channels)	10 mV	Alignment	As desired
VARIABLE (VOLTS/DIV) (both channels)	CAL	Calibrator	Off
STEP ATTEN BALANCE (both channels)	As is	Power	On
POSITION (both channels)	Midrange	Scale Illum	As desired
<b>+ Input Coupling (channel 1)</b>	<b>DC</b>	<b>2B- or 3B-Series Plug-In</b>	
+ Input Coupling (channel 2)	GND	Calibration	Adjust as per instruction manual procedure
- Input Coupling (both channels)	GND	Position	Midrange
MODE	CH 1	Mode	Normal
<b>TRIGGER</b>	<b>CH 1</b>	Time/Div	0.5 ms
BANDWIDTH	500 kHz	Variable (Time/Div)	Calibrated
GAIN	As is	5x Mag	Off
<b>Calibration Oscilloscope</b>		Stability	Adjust as per instruction manual procedure
Intensity	As desired	Source	Internal
Focus	Adjust for a well defined display	Coupling	AC Slow
		Slope	+
		<b>Level</b>	<b>Automatic</b>



### 37. Adjust Trigger Amplifier High Frequency Compensation

- a. Test equipment setup is shown in Fig. 6-22.
- b. Connect a 1 kHz square-wave signal from a square-wave generator via a 5 ns coaxial cable, a 50 ohm GR to BNC termination and a 10× BNC attenuator to the Type 3A3 channel 1 + input connector.
- c. Connect a 10× probe from the vertical input connector of the test oscilloscope to pin 8 of V583, see Fig. 6-23.
- d. Set the test oscilloscope for a deflection factor of 0.2 volts/division, AC coupled at a sweep rate of 0.5 ms/division with internal triggering.
- e. Adjust the output square-wave signal amplitude until a display exactly 4 major divisions high is displayed on the calibration oscilloscope.
- f. CHECK—Test oscilloscope display; displayed square-wave should have an optimum square leading corner and a flat top.

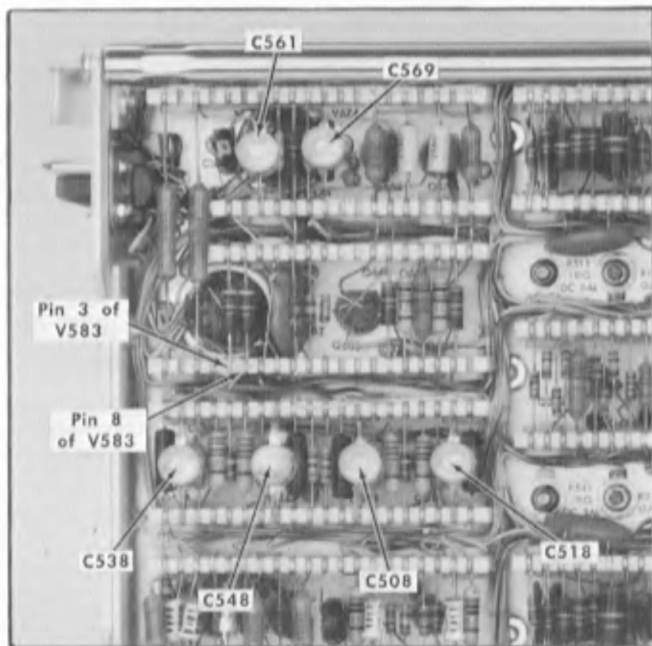


Fig. 6-23. Location of trigger amplifier high frequency compensation test points and adjustments.

- g. ADJUST—C508, see Fig. 6-23, until the test oscilloscope square-wave display has an optimum square leading corner and a flat top.
- h. CHECK—Test oscilloscope display; displayed square-wave risetime should be 1  $\mu$ s or faster and the amplitude should be at least 8 volts.
- i. Disconnect the 10× probe from pin 8 of V583 and connect it to pin 3 of V583; see Fig. 6-23.

- j. CHECK—Test oscilloscope display; displayed square-wave should have an optimum square leading corner and a flat top.
- k. ADJUST—C518, see Fig. 6-23, until the test oscilloscope square-wave display has an optimum square leading corner and a flat top.
- l. CHECK—Test oscilloscope display; displayed square-wave risetime should be 1  $\mu$ s or faster and the amplitude should be at least 8 volts.
- m. Set the channel 1 + Input Coupling switch to GND, channel 2 + Input Coupling switch to DC, the MODE switch to CH 2 and the TRIGGER switch to CH 2.
- n. Disconnect the square-wave signal from the channel 1 + input connector and connect the 1 kHz square-wave signal from the square-wave generator via a 5 ns coaxial cable, a 50 ohm GR to BNC termination and a 10× BNC attenuator to the Type 3A3 channel 2 + input connector.
- o. Disconnect the 10× probe from pin 3 of V583 and connect it to pin 8 of V583; see Fig. 6-23.
- p. Adjust the output square-wave signal amplitude until a display exactly 4 major divisions high is displayed on the calibration oscilloscope.
- q. CHECK—Test oscilloscope display; displayed square-wave should have an optimum square leading corner and a flat top.
- r. ADJUST—C538, see Fig. 6-23, until the test oscilloscope square-wave display has an optimum square leading corner and a flat top.
- s. CHECK—Test oscilloscope display; displayed square-wave risetime should be 1  $\mu$ s or faster and the amplitude should be at least 8 volts.
- t. Disconnect the 10× probe from pin 8 of V583 and connect it to pin 3 of V583, see Fig. 6-23.
- u. CHECK—Test oscilloscope display; displayed square-wave should have an optimum square leading corner and a flat top.
- v. ADJUST—C548, see Fig. 6-23, until the test oscilloscope square-wave display has an optimum square leading corner and a flat top.
- w. CHECK—Test oscilloscope display; displayed square-wave risetime should be 1  $\mu$ s or faster and the amplitude should be at least 8 volts.
- x. Set the Type 3A3 TRIGGER switch to COMP.
- y. Disconnect the 10× probe from pin 3 of V583 and connect it to pin 8 of V583; see Fig. 6-23.
- z. CHECK—Test oscilloscope display; displayed square-wave should have an optimum square leading corner and a flat top.



aa. ADJUST—C561, see Fig. 6-23, until the test oscilloscope square-wave display has an optimum square leading corner and a flat top.

ab. CHECK—Test oscilloscope display; displayed square-wave risetime should be  $1 \mu\text{s}$  or faster and the amplitude should be at least 10 volts.

ac. Disconnect the  $10\times$  probe from pin 8 of V583 and connect it to pin 3 of V583; see Fig. 6-23.

ad. CHECK—Test oscilloscope display; displayed square-wave should have an optimum square leading corner and a flat top.

ae. ADJUST—C569, see Fig. 6-23, until the test oscilloscope square-wave display has an optimum square leading corner and a flat top.

af. CHECK—Test oscilloscope display; displayed square-wave risetime should be  $1 \mu\text{s}$  or faster and the amplitude should be at least 10 volts.

ag. Disconnect the square-wave generator, test oscilloscope. 5 ns coaxial cable, 50 ohm GR to BNC termination,  $10\times$  BNC termination and the  $10\times$  probe.

### 38. Check Alternate Mode of Operation

a. Set the channel 2 + Input Coupling switch to GND and the MODE switch to ALT.

b. Set the 2B- or 3B-series plug-in level control to its free run position.

c. Using the channel 1 and 2 POSITION controls, move the two traces so they are about 2 major divisions apart.

d. Rotate the 2B- or 3B-series plug-in time/div switch throughout its range.

e. CHECK—Calibration oscilloscope display; one channel should be displayed, then the other alternately, as part d of this step is performed.

### 39. Check Chopped Mode of Operation

a. Set the Type 3A3 MODE switch to CHOP.

b. Set the Type 2B- or 3B-series plug-in time/div switch to  $1 \mu\text{s}$  and the level control to its automatic position.

c. Set the CRT cathode selector switch on the rear-panel of the calibration oscilloscope to its ext CRT cathode position.

d. Using the channel 1 and 2 POSITION controls, obtain a display which will appear as a 2 major division square-wave signal. Note that the channel 1 POSITION control controls the top of the display, and the channel 2 POSITION control controls the bottom of the display.

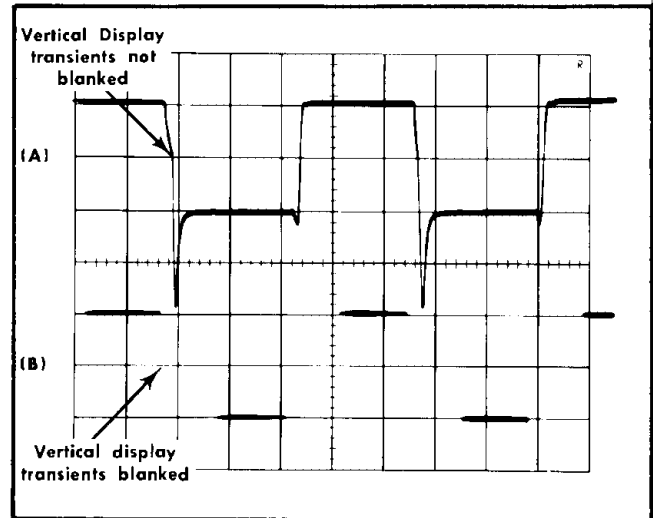


Fig. 6-24. Display presented when calibration oscilloscope CRT cathode selector switch set to: (A) Ext CRT cathode (B) Chopped blanking.

e. CHECK—Calibration oscilloscope display; one cycle of the square-wave appearing display should occupy from 4 major divisions to 6.6 major divisions ( $4 \mu\text{s}$  to  $6.6 \mu\text{s}$ ) of sweep.

f. Set the CRT cathode selector switch on the rear-panel of the calibration oscilloscope to its chopped blanking position.

g. CHECK—Calibration oscilloscope display; the vertical display transients should now be blanked out during the switching interval (see Fig. 6-24).

### 40. (Optional Step) Check Dual-Trace X-Y Operation

#### NOTE

This step can be performed only if two calibrated Type 3A3 plug-ins are available and a 560-series calibration oscilloscope other than a Type 565 or RM565 is available.

a. Remove the 2B- or 3B-series plug-in from the horizontal plug-in compartment of the calibration oscilloscope.

b. Install a second calibrated Type 3A3 into the horizontal plug-in compartment of the calibration oscilloscope.

### Calibration—Type 3A3

c. Set the controls of both Type 3A3 plug-ins as follows:

VOLTS/DIV (both channels)	10 V
+ Input Coupling (both channels)	GND
— Input Coupling (both channels)	GND
MODE (vertical plug-in compartment)	CHOP
MODE (horizontal plug-in compartment)	ALT

d. Rotate each POSITION control of each channel on each Type 3A3 plug-in throughout its range.

e. CHECK—Calibration oscilloscope display; a display of only two spots should be obtained and each POSITION control on the two plug-ins should affect only one spot as part d of this step is performed.

This completes the calibration of the Type 3A3. Disconnect all test equipment and replace the left and right side covers on the calibration oscilloscope.



## PARTS ORDERING INFORMATION

Replacement parts are available from or through your local Tektronix, Inc. Field Office or representative.

Changes to Tektronix instruments are sometimes made to accommodate improved components as they become available, and to give you the benefit of the latest circuit improvements developed in our engineering department. It is therefore important, when ordering parts, to include the following information in your order: Part number, instrument type or number, serial or model number, and modification number if applicable.

If a part you have ordered has been replaced with a new or improved part, your local Tektronix, Inc. Field Office or representative will contact you concerning any change in part number.

## SPECIAL NOTES AND SYMBOLS

- |   |   |
|---|---|
| ×000  | Part first added at this serial number  |
| 00×   | Part removed after this serial number   |
| *000-0000-00  | Asterisk preceding Tektronix Part Number indicates manufactured by or for Tektronix, Inc., or reworked or checked components. |
| Use 000-0000-00   | Part number indicated is direct replacement.  |
|  | Screwdriver adjustment.   |
|  | Control, adjustment or connector.   |

## PARTS LIST ABBREVIATIONS

BHB	binding head brass	int	internal
BHS	binding head steel	lg	length or long
cap.	capacitor	met.	metal
cer	ceramic	mtg hdw	mounting hardware
comp	composition	OD	outside diameter
conn	connector	OHB	oval head brass
CRT	cathode-ray tube	OHS	oval head steel
csk	countersunk	PHB	pan head brass
DE	double end	PHS	pan head steel
dia	diameter	plstc	plastic
div	division	PMC	paper, metal cased
elect.	electrolytic	poly	polystyrene
EMC	electrolytic, metal cased	prec	precision
EMT	electrolytic, metal tubular	PT	paper, tubular
ext	external	PTM	paper or plastic, tubular, molded
F & I	focus and intensity	RHB	round head brass
FHB	flat head brass	RHS	round head steel
FHS	flat head steel	SE	single end
Fil HB	fillister head brass	SN or S/N	serial number
Fil HS	fillister head steel	SW	switch
h	height or high	TC	temperature compensated
hex.	hexagonal	THB	truss head brass
HHB	hex head brass	thk	thick
HHS	hex head steel	THS	truss head steel
HSB	hex socket brass	tub.	tubular
HSS	hex socket steel	var	variable
ID	inside diameter	w	wide or width
incd	incandescent	WW	wire-wound

# SECTION 7

## ELECTRICAL PARTS LIST

Values are fixed unless marked Variable.

Ckt. No.	Tektronix Part No.	Serial/Model No. Eff	Disc	Description		
<b>Capacitors</b>						
Tolerance $\pm 20\%$ unless otherwise indicated.						
C101 <sup>1</sup>	*295-0081-00			0.1 $\mu\text{F}$	MT	600 V
C102	281-0504-00			10 pF	Cer	500 V
C105A	281-0093-00			5.5-18 pF, Var	Cer	
C105C	281-0091-00			2-8 pF, Var	Cer	
C105E	283-0603-00			113 pF	Mica	300 V
C105F	281-0576-00			11 pF	Cer	500 V
C106A	281-0093-00			5.5-18 pF, Var	Cer	
C106C	281-0091-00			2-8 pF, Var	Cer	
C106E	283-0597-00			470 pF	Mica	300 V
C107A	281-0093-00			5.5-18 pF, Var	Cer	
C107C	281-0091-00			2-8 pF, Var	Cer	
C107E	283-0100-00			0.0047 $\mu\text{F}$	Cer	200 V
C109	281-0091-00			2-8 pF, Var	Cer	
C111	*285-0756-00			0.05 $\mu\text{F}$	Plastic	400 V
C112	281-0609-00			1 pF	Cer	200 V
C114	281-0661-00			0.8 pF	Cer	500 V
C115	281-0060-00			2-8 pF, Var	Cer	
C116	281-0053-00			0.35-1.37 pF, Var	Plastic	
C181	285-0622-00			0.1 $\mu\text{F}$	PTM	100 V
C187	283-0057-00			0.1 $\mu\text{F}$	Cer	200 V
C201 <sup>1</sup>	*295-0081-00			0.1 $\mu\text{F}$	MT	600 V
C202	281-0504-00			10 pF	Cer	500 V
C205A	281-0093-00			5.5-18 pF, Var	Cer	
C205C	281-0091-00			2-8 pF, Var	Cer	
C205E	283-0603-00			113 pF	Mica	300 V
C205F	281-0576-00			11 pF	Cer	500 V
C206A	281-0093-00			5.5-18 pF, Var	Cer	
C206C	281-0091-00			2-8 pF, Var	Cer	
C206E	283-0597-00			470 pF	Mica	300 V
C207A	281-0093-00			5.5-18 pF, Var	Cer	
C207C	281-0091-00			2-8 pF, Var	Cer	
C207E	283-0100-00			0.0047 $\mu\text{F}$	Cer	200 V
C209	281-0091-00			2-8 pF, Var	Cer	
C211	*285-0756-00			0.05 $\mu\text{F}$	Plastic	400 V
C212	281-0053-00			0.35-1.37 pF, Var	Plastic	
C214	281-0064-00			0.25-1.5 pF, Var	Tub.	
C215	281-0618-00			4.7 pF	Cer	200 V

<sup>1</sup>C101 and C201 matched within  $\pm 1\%$  of each other, furnished as a unit.

Electrical Parts List—Type 3A3

Capacitors (cont)

Ckt. No.	Tektronix Part No.	Serial/Model No. Eff	No. Disc	Description		
C216	281-0053-00			0.35-1.37 pF, Var	Plastic	
C251A	283-0605-00			678 pF	Mica	300 V 1%
C251B	281-0092-00			9-35 pF, Var	Cer	
C251C	283-0604-00			304 pF	Mica	300 V 2%
C251D	281-0092-00			9-35 pF, Var	Cer	
C251E	283-0603-00			113 pF	Mica	300 V 2%
C251F	281-0093-00			5.5-18 pF, Var	Cer	
C251G	283-0602-00			53 pF	Mica	300 V 5%
C251H	281-0093-00			5.5-18 pF, Var	Cer	
C251J	283-0601-00			22 pF	Mica	300 V 10%
C251K	281-0091-00			2-8 pF, Var	Cer	
C251L	281-0091-00			2-8 pF, Var	Cer	
C251M	281-0064-00			0.25-1.5 pF, Var	Tub.	
C251N	281-0627-00	X5000		1 pF	Cer	600 V
C260	281-0620-00			21 pF	Cer	500 V
C261	283-0088-00			1100 pF	Cer	500 V 5%
C281	285-0622-00			0.1 μF	PTM	100 V
C301 <sup>2</sup>	*295-0081-00			0.1 μF	MT	600 V 10%
C302	281-0504-00			10 pF	Cer	500 V 10%
C305A	281-0093-00			5.5-18 pF, Var	Cer	
C305C	281-0091-00			2-8 pF, Var	Cer	
C305E	283-0603-00			113 pF	Mica	300 V 2%
C305F	281-0576-00			11 pF	Cer	500 V 5%
C306A	281-0093-00			5.5-18 pF, Var	Cer	
C306C	281-0091-00			2-8 pF, Var	Cer	
C306E	283-0597-00			470 pF	Mica	300 V 10%
C307A	281-0093-00			5.5-18 pF, Var	Cer	
C307C	281-0091-00			2-8 pF, Var	Cer	
C307E	283-0100-00			0.0047 μF	Cer	200 V 10%
C309	281-0091-00			2-8 pF, Var	Cer	
C311	*285-0756-00			0.05 μF	Plastic	400 V 5%
C312	281-0609-00			1 pF	Cer	200 V 10%
C314	281-0661-00			0.8 pF	Cer	500 V ±0.1 pF
C315	281-0060-00			2-8 pF, Var	Cer	
C316	281-0053-00			0.35-1.37 pF, Var	Plastic	
C381	285-0622-00			0.1 μF	PTM	100 V
C387	283-0057-00			0.1 μF	Cer	200 V
C401 <sup>2</sup>	*295-0081-00			0.1 μF	MT	600 V 10%
C402	281-0504-00			10 pF	Cer	500 V 10%
C405A	281-0093-00			5.5-18 pF, Var	Cer	
C405C	281-0091-00			2-8 pF, Var	Cer	
C405E	283-0603-00			113 pF	Mica	300 V 2%
C405F	281-0576-00			11 pF	Cer	500 V 5%
C406A	281-0093-00			5.5-18 pF, Var	Cer	
C406C	281-0091-00			2-8 pF, Var	Cer	
C406E	283-0597-00			470 pF	Mica	300 V 10%
C407A	281-0093-00			5.5-18 pF, Var	Cer	
C407C	281-0091-00			2-8 pF, Var	Cer	

<sup>2</sup>C301 and C401 matched within ±1% of each other, furnished as a unit.

## Capacitors (cont)

Ckt. No.	Tektronix Part No.	Serial/Model No. Eff	Disc	Description		
C407E	283-0100-00		0.0047 $\mu$ F	Cer	200 V	10%
C409	281-0091-00		2-8 pF, Var	Cer		
C411	*285-0756-00		0.05 $\mu$ F	Plastic	400 V	5%
C412	281-0053-00		0.35-1.37 pF, Var	Plastic		
C414	281-0064-00		0.25-1.5 pF, Var	Tub.		
C415	281-0618-00		4.7 pF	Cer	200 V	
C416	281-0053-00		0.35-1.37 pF, Var	Plastic		
C451A	283-0605-00		678 pF	Mica	300 V	1%
C451B	281-0092-00		9-35 pF, Var	Cer		
C451C	283-0604-00		304 pF	Mica	300 V	2%
C451D	281-0092-00		9-35 pF, Var	Cer		
C451E	283-0603-00		113 pF	Mica	300 V	2%
C451F	281-0093-00		5.5-18 pF, Var	Cer		
C451G	283-0602-00		53 pF	Mica	300 V	5%
C451H	281-0093-00		5.5-18 pF, Var	Cer		
C451J	283-0601-00		22 pF	Mica	300 V	10%
C451K	281-0091-00		2-8 pF, Var	Cer		
C451L	281-0091-00		2-8 pF, Var	Cer		
C451M	281-0064-00		0.25-1.5 pF, Var	Tub.		
C451N	281-0627-00	X5000	1 pF	Cer	600 V	
C460	281-0620-00		21 pF	Cer	500 V	1%
C461	283-0088-00		1100 pF	Cer	500 V	5%
C481	285-0622-00		0.1 $\mu$ F	PTM	100 V	
C508	281-0094-00		5.5-18 pF, Var	Cer		
C509	283-0601-00		22 pF	Mica	300 V	10%
C518	281-0094-00		5.5-18 pF, Var	Cer		
C519	283-0601-00		22 pF	Mica	300 V	10%
C538	281-0094-00		5.5-18 pF, Var	Cer		
C539	283-0601-00		22 pF	Mica	300 V	10%
C548	281-0094-00		5.5-18 pF, Var	Cer		
C549	283-0601-00		22 pF	Mica	300 V	10%
C561	281-0094-00		5.5-18 pF, Var	Cer		
C562	281-0504-00		10 pF	Cer	500 V	10%
C568	281-0504-00		10 pF	Cer	500 V	10%
C569	281-0094-00		5.5-18 pF, Var	Cer		
C604	281-0552-00		25 pF	Cer	500 V	
C615	281-0552-00		25 pF	Cer	500 V	
C619	281-0540-00		51 pF	Cer		5%
C621	281-0552-00		25 pF	Cer	500 V	
C631	281-0510-00		22 pF	Cer	500 V	10%
C633	281-0513-00		27 pF	Cer	500 V	
C638	281-0518-00		47 pF	Cer	500 V	
C661	285-0651-01		0.0017 $\mu$ F	PTM	100 V	5%
C671	285-0651-01		0.0017 $\mu$ F	PTM	100 V	5%
C680	283-0006-00		0.02 $\mu$ F	Cer	500 V	
C682	290-0285-00		4 $\mu$ F	Elect.	200 V	+50%—10%

**Electrical Parts List—Type 3A3**

**Capacitors (cont)**

Ckt. No.	Tektronix Part No.	Serial/Model No. Eff	Disc	Description
C683	290-0285-00		4 $\mu$ F	Elect. 200 V +50%—10%
C687	283-0057-00		0.1 $\mu$ F	Cer 200 V +80%—20%
C695	290-0135-00		15 $\mu$ F	Elect. 20 V
C699	283-0129-00		0.56 pF	Cer 100 V

**Semiconductor Device, Diodes**

D113	*152-0165-00		Silicon	Selected from 1N3579
D123	*152-0061-00		Silicon	Tek Spec
D124	152-0195-00		Zener	1N751A 400 mW, 5.1 V, 5%
D127	152-0282-00		Zener	1N972B 400 mW, 30 V, 5%
D129	152-0282-00		Zener	1N972B 400 mW, 30 V, 5%
D142	*152-0185-00		Silicon	Replaceable by 1N4152
D213	*152-0165-00		Silicon	Selected from 1N3579
D242	*152-0185-00		Silicon	Replaceable by 1N4152
D313	*152-0165-00		Silicon	Selected from 1N3579
D323	*152-0061-00		Silicon	Tek Spec
D324	152-0195-00		Zener	1N751A 400 mW, 5.1 V, 5%
D327	152-0282-00		Zener	1N972B 400 mW, 30 V, 5%
D329	152-0282-00		Zener	1N972B 400 mW, 30 V, 5%
D342	*152-0185-00		Silicon	Replaceable by 1N4152
D413	*152-0165-00		Silicon	Selected from 1N3579
D442	*152-0185-00		Silicon	Replaceable by 1N4152
D604	152-0141-00		Silicon	1N4152
D614	152-0141-00		Silicon	1N4152
D622	152-0141-00		Silicon	1N4152
D625	152-0141-00		Silicon	1N4152
D630	152-0141-00		Silicon	1N4152
D632	152-0141-00		Silicon	1N4152
D635	152-0141-00		Silicon	1N4152
D641	152-0141-00		Silicon	1N4152
D642	152-0141-00		Silicon	1N4152
D643	152-0141-00		Silicon	1N4152
D644	152-0141-00		Silicon	1N4152
D645	152-0141-00		Silicon	1N4152
D646	152-0141-00		Silicon	1N4152
D651	152-0141-00		Silicon	1N4152
D652	152-0141-00		Silicon	1N4152
D653	152-0141-00		Silicon	1N4152
D654	152-0141-00		Silicon	1N4152
D655	152-0141-00		Silicon	1N4152
D656	152-0141-00		Silicon	1N4152
D687	152-0149-00		Zener	1N961B 400 mW, 10 V, 5%
D688	152-0141-00		Silicon	1N4152
D689	152-0141-00		Silicon	1N4152
D699	152-0150-00		Zener	1N3037B 400 mW, 51 V, 5%



**Inductors**

Ckt. No.	Tektronix Part No.	Serial/Model No. Eff	No. Disc	Description
L174	276-0541-00			Core, Ferrite
L261	*108-0287-00			Reed Drive
L274	276-0541-00			Core, Ferrite
L374	276-0541-00			Core, Ferrite
L461	*108-0287-00			Reed Drive
L474	276-0541-00			Core, Ferrite
L504	276-0507-00			Core, Ferramic Suppressor
L514	276-0507-00			Core, Ferramic Suppressor
L534	276-0507-00			Core, Ferramic Suppressor
L544	276-0507-00			Core, Ferramic Suppressor
L569	276-0507-00			Core, Ferramic Suppressor
L570	276-0507-00			Core, Ferramic Suppressor
L571	276-0507-00			Core, Ferramic Suppressor
L572	276-0507-00			Core, Ferramic Suppressor
L631	*120-0312-00			Toroid, 15 turns single
L695	*120-0202-00			Toroid, 15 turns single

**Transistors**

Q113	*151-0216-00		Silicon	Replaceable by Mot MPS 6523
Q114A,B	151-1019-00		Dual	FET
Q118	151-0133-00		Silicon	2N3251
Q128	*151-0103-00		Silicon	Replaceable by 2N2219
Q133	151-0188-00		Silicon	2N3906
Q134	151-0190-00		Silicon	2N3904
Q143	151-0190-00		Silicon	2N3904
Q154	151-0190-00		Silicon	2N3904
Q163	151-0188-00		Silicon	2N3906
Q174	151-0188-00		Silicon	2N3906
Q213	*151-0216-00		Silicon	Replaceable by Mot MPS 6523
Q233	151-0188-00		Silicon	2N3906
Q234	151-0190-00		Silicon	2N3904
Q243	151-0190-00		Silicon	2N3904
Q254	151-0190-00		Silicon	2N3904
Q263	151-0188-00		Silicon	2N3906
Q274	151-0188-00		Silicon	2N3906
Q313	*151-0216-00		Silicon	Replaceable by Mot MPS 6523
Q314A,B	151-1019-00		Dual	FET
Q318	151-0133-00		Silicon	2N3251
Q328	*151-0103-00		Silicon	Replaceable by 2N2219
Q333	151-0188-00		Silicon	2N3906
Q334	151-0190-00		Silicon	2N3904
Q343	151-0190-00		Silicon	2N3904
Q354	151-0190-00		Silicon	2N3904
Q363	151-0188-00		Silicon	2N3906
Q374	151-0188-00		Silicon	2N3906
Q413	*151-0216-00		Silicon	Replaceable by Mot MPS 6523
Q433	151-0188-00		Silicon	2N3906
Q434	151-0190-00		Silicon	2N3904

## Electrical Parts List—Type 3A3

### Transistors (cont)

Ckt. No.	Tektronix Part No.	Serial/Model No. Eff	Disc	Description
Q443	151-0190-00		Silicon	2N3904
Q454	151-0190-00		Silicon	2N3904
Q463	151-0188-00		Silicon	2N3906
Q474	151-0188-00		Silicon	2N3906
Q504	151-0188-00		Silicon	2N3906
Q514	151-0188-00		Silicon	2N3906
Q534	151-0188-00		Silicon	2N3906
Q544	151-0188-00		Silicon	2N3906
Q605	151-0188-00		Silicon	2N3906
Q615	151-0188-00		Silicon	2N3906
Q625	*151-0103-00		Silicon	Replaceable by 2N2219
Q635	*151-0103-00		Silicon	Replaceable by 2N2219
Q644	151-0188-00		Silicon	2N3906
Q654	151-0188-00		Silicon	2N3906
Q663	151-0188-00		Silicon	2N3906
Q664	*151-0103-00		Silicon	Replaceable by 2N2219
Q673	151-0188-00		Silicon	2N3906
Q674	*151-0103-00		Silicon	Replaceable by 2N2219
Q684	*151-0103-00		Silicon	Replaceable by 2N2219

### Resistors

Resistors are fixed, composition,  $\pm 10\%$  unless otherwise indicated.

R101	315-0105-00	1 M $\Omega$	1/4 W		5%
R102	315-0101-00	100 $\Omega$	1/4 W		5%
R105C	323-0611-01	900 k $\Omega$	1/2 W	Prec	1/2%
R105E	321-1388-01	109 k $\Omega$	1/8 W	Prec	1/2%
R105F	311-0833-00	5 k $\Omega$ , Var			
R106C	323-0614-01	990 k $\Omega$	1/2 W	Prec	1/2%
R106E	321-1288-01	9.88 k $\Omega$	1/8 W	Prec	1/2%
R106F	311-0834-00	500 $\Omega$ , Var			
R107C	323-0481-01	1 M $\Omega$	1/2 W	Prec	1/2%
R107E	321-0189-00	909 $\Omega$	1/8 W	Prec	1%
R107F	311-0441-00	200 $\Omega$ , Var			
R110	311-0441-00	200 $\Omega$ , Var			
R111	308-0486-00	20 k $\Omega$	4 W	WW	5%
R113	323-0481-01	1 M $\Omega$	1/2 W	Prec	1/2%
R114	321-0604-00	30 k $\Omega$	1/8 W	Prec	1%
R116	321-0131-00	226 $\Omega$	1/8 W	Prec	1%
R117	323-0322-00	22.1 k $\Omega$	1/2 W	Prec	1%
R118	323-0322-00	22.1 k $\Omega$	1/2 W	Prec	1%
R119	321-0353-00	46.4 k $\Omega$	1/8 W	Prec	1%
R120	315-0101-00	100 $\Omega$	1/4 W		5%
R124	321-0298-00	12.4 k $\Omega$	1/8 W	Prec	1%
R125	323-0296-00	11.8 k $\Omega$	1/2 W	Prec	1%
R127	301-0473-00	47 k $\Omega$	1/2 W		5%
R128	315-0101-00	100 $\Omega$	1/4 W		5%
R129	301-0303-00	30 k $\Omega$	1/2 W		5%
R130	315-0824-00	820 k $\Omega$	1/4 W		5%

## Resistors (cont)

Ckt. No.	Tektronix Part No.	Serial/Model No. Eff	Disc	Description		
R131	311-0839-00		50 $\Omega$ , Var			
R133	323-0331-00		27.4 k $\Omega$	1/2 W	Prec	1%
R134	323-0326-00		24.3 k $\Omega$	1/2 W	Prec	1%
R135	321-0193-00		1000 $\Omega$	1/8 W	Prec	1%
R136	321-0331-00		27.4 k $\Omega$	1/8 W	Prec	1%
R137	307-0181-00		100 k $\Omega$	Thermal		10%
R142	315-0101-00		100 $\Omega$	1/4 W		5%
R143	315-0223-00		22 k $\Omega$	1/4 W		5%
R144	301-0133-00		13 k $\Omega$	1/2 W		5%
R153	323-0296-00		11.8 k $\Omega$	1/2 W	Prec	1%
R154	322-0298-00		12.4 k $\Omega$	1/4 W	Prec	1%
R157	323-0385-00		100 k $\Omega$	1/2 W	Prec	1%
R159	311-0086-00		2.5 k $\Omega$ , Var			
R161	315-0101-00		100 $\Omega$	1/4 W		5%
R163	301-0243-00		24 k $\Omega$	1/2 W		5%
R173	322-0310-00		16.5 k $\Omega$	1/4 W	Prec	1%
R175	311-0086-00		2.5 k $\Omega$ , Var			
R181	315-0333-00		33 k $\Omega$	1/4 W		5%
R183	315-0473-00		47 k $\Omega$	1/4 W		5%
R185	311-0580-00		50 k $\Omega$ , Var			
R187	303-0753-00		75 k $\Omega$	1 W		5%
R201	315-0105-00		1 M $\Omega$	1/4 W		5%
R202	315-0101-00		100 $\Omega$	1/4 W		5%
R205C	323-0611-01		900 k $\Omega$	1/2 W	Prec	1/2%
R205F	321-1389-01		111 k $\Omega$	1/8 W	Prec	1/2%
R206C	323-0614-01		990 k $\Omega$	1/2 W	Prec	1/2%
R206F	321-1289-01		10.1 k $\Omega$	1/8 W	Prec	1/2%
R207C	323-0481-01		1 M $\Omega$	1/2 W	Prec	1/2%
R207F	321-0193-01		1 k $\Omega$	1/8 W	Prec	1/2%
R210	311-0441-00		200 $\Omega$ , Var			
R211	308-0486-00		20 k $\Omega$	4 W	WW	5%
R213	323-0481-01		1 M $\Omega$	1/2 W	Prec	1/2%
R214	321-0604-00		30 k $\Omega$	1/8 W	Prec	1%
R216	321-0131-00		226 $\Omega$	1/8 W	Prec	1%
R230	315-0824-00		820 k $\Omega$	1/4 W		5%
R233	323-0331-00		27.4 k $\Omega$	1/2 W	Prec	1%
R234	323-0326-00		24.3 k $\Omega$	1/2 W	Prec	1%
R235	311-0258-00		100 $\Omega$ , Var			
R239	321-0327-00		24.9 k $\Omega$	1/8 W	Prec	1%
R242	315-0101-00		100 $\Omega$	1/4 W		5%
R243	315-0223-00		22 k $\Omega$	1/4 W		5%
R251A	321-0765-01		969 $\Omega$	1/8 W	Prec	1/2%
R251C	321-1221-01		1.98 k $\Omega$	1/8 W	Prec	1/2%
R251E	321-0764-01		5.09 k $\Omega$	1/8 W	Prec	1/2%
R251G	322-0291-01		10.5 k $\Omega$	1/4 W	Prec	1/2%

**Electrical Parts List—Type 3A3**
**Resistors (cont)**

Ckt. No.	Tektronix Part No.	Serial/Model No. Eff	Disc	Description		
R251J	323-0322-01		22.1 k $\Omega$	1/2 W	Prec	1/2 %
R251L	323-0713-01		65.2 k $\Omega$	1/2 W	Prec	1/2 %
R251M	323-0714-01		192.2 k $\Omega$	1/2 W	Prec	1/2 %
R254	322-0298-00		12.4 k $\Omega$	1/4 W	Prec	1 %
R257	323-0385-00		100 k $\Omega$	1/2 W	Prec	1 %
R261	315-0101-00		100 $\Omega$	1/4 W		5 %
R263	301-0243-00		24 k $\Omega$	1/2 W		5 %
R264	301-0123-00		12 k $\Omega$	1/2 W		5 %
R273	322-0310-00		16.5 k $\Omega$	1/4 W	Prec	1 %
R275	311-0435-00		7 k $\Omega$ , Var			
R277	322-0193-00		1 k $\Omega$	1/4 W	Prec	1 %
R281	315-0333-00		33 k $\Omega$	1/4 W		5 %
R283	315-0473-00		47 k $\Omega$	1/4 W		5 %
R301	315-0105-00		1 M $\Omega$	1/4 W		5 %
R302	315-0101-00		100 $\Omega$	1/4 W		5 %
R305C	323-0611-01		900 k $\Omega$	1/2 W	Prec	1/2 %
R305E	321-1388-01		109 k $\Omega$	1/8 W	Prec	1/2 %
R305F	311-0833-00		5 k $\Omega$ , Var			
R306C	323-0614-01		990 k $\Omega$	1/2 W	Prec	1/2 %
R306E	321-1288-01		9.88 k $\Omega$	1/8 W	Prec	1/2 %
R306F	311-0834-00		500 $\Omega$ , Var			
R307C	323-0481-01		1 M $\Omega$	1/2 W	Prec	1/2 %
R307E	321-0189-00		909 $\Omega$	1/8 W	Prec	1 %
R307F	311-0441-00		200 $\Omega$ , Var			
R310	311-0441-00		200 $\Omega$ , Var			
R311	308-0486-00		20 k $\Omega$	4 W	WW	5 %
R313	323-0481-01		1 M $\Omega$	1/2 W	Prec	1/2 %
R314	321-0604-00		30 k $\Omega$	1/8 W	Prec	1 %
R316	321-0131-00		226 $\Omega$	1/8 W	Prec	1 %
R317	323-0322-00		22.1 k $\Omega$	1/2 W	Prec	1 %
R318	323-0322-00		22.1 k $\Omega$	1/2 W	Prec	1 %
R319	321-0353-00		46.4 k $\Omega$	1/8 W	Prec	1 %
R320	315-0101-00		100 $\Omega$	1/4 W		5 %
R324	321-0298-00		12.4 k $\Omega$	1/8 W	Prec	1 %
R325	323-0296-00		11.8 k $\Omega$	1/2 W	Prec	1 %
R327	301-0473-00		47 k $\Omega$	1/2 W		5 %
R328	315-0101-00		100 $\Omega$	1/4 W		5 %
R329	301-0303-00		30 k $\Omega$	1/2 W		5 %
R330	315-0824-00		820 k $\Omega$	1/4 W		5 %
R331	311-0839-00		50 $\Omega$ , Var			
R333	323-0331-00		27.4 k $\Omega$	1/2 W	Prec	1 %
R334	323-0326-00		24.3 k $\Omega$	1/2 W	Prec	1 %
R337	307-0181-00		100 k $\Omega$	Thermal		10 %
R342	315-0101-00		100 $\Omega$	1/4 W		5 %
R343	315-0223-00		22 k $\Omega$	1/4 W		5 %

Resistors (cont)

Ckt. No.	Tektronix Part No.	Serial/Model No. Eff	Disc	Description		
R344	301-0133-00		13 kΩ	1/2 W		5%
R353	323-0296-00		11.8 kΩ	1/2 W	Prec	1%
R354	322-0298-00		12.4 kΩ	1/4 W	Prec	1%
R357	323-0385-00		100 kΩ	1/2 W	Prec	1%
R359	311-0086-00		2.5 kΩ, Var			
R361	315-0101-00		100 Ω	1/4 W		5%
R363	301-0243-00		24 kΩ	1/2 W		5%
R373	322-0310-00		16.5 kΩ	1/4 W	Prec	1%
R375	311-0086-00		2.5 kΩ, Var			
R381	315-0333-00		33 kΩ	1/4 W		5%
R383	315-0473-00		47 kΩ,	1/4 W		5%
R385	311-0580-00		50 kΩ, Var			
R387	303-0753-00		75 kΩ	1 W		5%
R401	315-0105-00		1 MΩ	1/4 W		5%
R402	315-0101-00		100 Ω	1/4 W		5%
R405C	323-0611-01		900 kΩ	1/2 W	Prec	1/2 %
R405E	321-1389-01		111 kΩ	1/8 W	Prec	1/2 %
R406C	323-0614-01		990 kΩ	1/2 W	Prec	1/2 %
R406E	321-1289-01		10.1 kΩ	1/8 W	Prec	1/2 %
R407C	323-0481-01		1 MΩ	1/2 W	Prec	1/2 %
R407E	321-0193-01		1 kΩ	1/8 W	Prec	1/2 %
R410	311-0441-00		200 Ω, Var			
R411	308-0486-00		20 kΩ	4 W	WW	5%
R413	323-0481-01		1 MΩ	1/2 W	Prec	1/2 %
R414	321-0604-00		30 kΩ	1/8 W	Prec	1%
R416	321-0131-00		226 Ω	1/8 W	Prec	1%
R430	315-0824-00		820 kΩ	1/4 W		5%
R433	323-0331-00		27.4 kΩ	1/2 W	Prec	1%
R434	323-0326-00		24.3 kΩ	1/2 W	Prec	1%
R435	311-0258-00		100 Ω, Var			
R439	321-0327-00		24.9 kΩ	1/8 W	Prec	1%
R442	315-0101-00		100 Ω	1/4 W		5%
R443	315-0223-00		22 kΩ	1/4 W		5%
R451A	321-0765-01		969 Ω	1/8 W	Prec	1/2 %
R451C	321-1221-01		1.98 kΩ	1/8 W	Prec	1/2 %
R451E	321-0764-01		5.09 kΩ	1/8 W	Prec	1/2 %
R451G	322-0291-01		10.5 kΩ	1/4 W	Prec	1/2 %
R451J	323-0322-01		22.1 kΩ	1/2 W	Prec	1/2 %
R451L	323-0713-01		65.2 kΩ	1/2 W	Prec	1/2 %
R451M	323-0714-01		192.2 kΩ	1/2 W	Prec	1/2 %
R454	322-0298-00		12.4 kΩ	1/4 W	Prec	1%
R457	323-0385-00		100 kΩ	1/2 W	Prec	1%
R461	315-0101-00		100 Ω	1/4 W		5%
R462	315-0101-00		100 Ω	1/4 W		5%
R463	301-0243-00		24 kΩ	1/2 W		5%

Electrical Parts List—Type 3A3

Resistors (cont)

Ckt. No.	Tektronix Part No.	Serial/Model No. Eff	No. Disc	Description		
R464	301-0123-00		12 kΩ	1/2 W		5%
R473	322-0310-00		16.5 kΩ	1/4 W	Prec	1%
R475	311-0435-00		7 kΩ, Var			
R477	322-0193-00		1 kΩ	1/4 W	Prec	1%
R481	315-0333-00		33 kΩ	1/4 W		5%
R483	315-0473-00		47 kΩ	1/4 W		5%
R501	315-0241-00		240 Ω	1/4 W		5%
R502	322-0322-00		22.1 kΩ	1/4 W	Prec	1%
R504	322-0298-00		12.4 kΩ	1/4 W	Prec	1%
R509	322-0610-00		500 kΩ	1/4 W	Prec	1%
R511	311-0387-00		5 kΩ, Var			
R512	322-0322-00		22.1 kΩ	1/4 W	Prec	1%
R514	322-0298-00		12.4 kΩ	1/4 W	Prec	1%
R515	321-0269-00		6.19 kΩ	1/8 W	Prec	1%
R519	322-0610-00		500 kΩ	1/4 W	Prec	1%
R523	322-0620-00		800 kΩ	1/4 W	Prec	1%
R525	311-0110-00		100 kΩ, Var			
R527	322-0620-00		800 kΩ	1/4 W	Prec	1%
R531	315-0241-00		240 Ω	1/4 W		5%
R532	322-0322-00		22.1 kΩ	1/4 W	Prec	1%
R534	322-0298-00		12.4 kΩ	1/4 W	Prec	1%
R539	322-0610-00		500 kΩ	1/4 W	Prec	1%
R541	311-0387-00		5 kΩ, Var			
R542	322-0322-00		22.1 kΩ	1/4 W	Prec	1%
R544	322-0298-00		12.4 kΩ	1/4 W	Prec	1%
R545	321-0269-00		6.19 kΩ	1/8 W	Prec	1%
R549	322-0610-00		500 kΩ	1/4 W	Prec	1%
R553	322-0620-00		800 kΩ	1/4 W	Prec	1%
R555	311-0110-00		100 kΩ, Var			
R557	322-0620-00		800 kΩ	1/4 W	Prec	1%
R561	322-0481-00		1 MΩ	1/4 W	Prec	1%
R563	321-0441-00		383 kΩ	1/8 W	Prec	1%
R565	311-0110-00		100 kΩ, Var			
R567	321-0441-00		383 kΩ	1/8 W	Prec	1%
R569	322-0481-00		1 MΩ	1/4 W	Prec	1%
R583	301-0473-00		47 kΩ	1/2 W		5%
R586	301-0473-00		47 kΩ	1/2 W		5%
R601	315-0474-00		470 kΩ	1/4 W		5%
R603	315-0473-00		47 kΩ	1/4 W		5%
R604	315-0203-00		20 kΩ	1/4 W		5%
R605	322-0654-00		920 Ω	1/4 W	Prec	1%
R611	315-0474-00		470 kΩ	1/4 W		5%
R613	315-0473-00		47 kΩ	1/4 W		5%
R614	315-0203-00		20 kΩ	1/4 W		5%
R615	322-0654-00		920 Ω	1/4 W	Prec	1%

## Resistors (cont)

Ckt. No.	Tektronix Part No.	Serial/Model No. Eff	No. Disc	Description		
R616	315-0103-00		10 k $\Omega$	1/4 W		5%
R621	308-0291-00		2 k $\Omega$	3 W	WW	5%
R622	315-0473-00		47 k $\Omega$	1/4 W		5%
R623	315-0102-00		1 k $\Omega$	1/4 W		5%
R624	315-0101-00		100 $\Omega$	1/4 W		5%
R630	315-0391-00		390 $\Omega$	1/4 W		5%
R631	308-0291-00		2 k $\Omega$	3 W	WW	5%
R632	315-0473-00		47 k $\Omega$	1/4 W		5%
R633	315-0102-00		1 k $\Omega$	1/4 W		5%
R634	315-0101-00		100 $\Omega$	1/4 W		5%
R635	308-0292-00		2.2 k $\Omega$	3 W	WW	5%
R638	315-0103-00		10 k $\Omega$	1/4 W		5%
R642	323-0296-00		11.8 k $\Omega$	1/2 W	Prec	1%
R643	322-0606-00		25.6 k $\Omega$	1/4 W	Prec	1%
R648	322-0604-00		5.03 k $\Omega$	1/4 W	Prec	1%
R649	323-0268-00		6.04 k $\Omega$	1/2 W	Prec	1%
R652	323-0296-00		11.8 k $\Omega$	1/2 W	Prec	1%
R653	322-0606-00		25.6 k $\Omega$	1/4 W	Prec	1%
R658	322-0604-00		5.03 k $\Omega$	1/4 W	Prec	1%
R660	315-0101-00		100 $\Omega$	1/4 W		5%
R661	321-0122-00		182 $\Omega$	1/8 W	Prec	1%
R662	308-0366-00		3.4 k $\Omega$	3 W	WW	1%
R663	301-0363-00		36 k $\Omega$	1/2 W		5%
R665	311-0169-00		100 $\Omega$ , Var			
R670	315-0101-00		100 $\Omega$	1/4 W		5%
R671	321-0122-00		182 $\Omega$	1/8 W	Prec	1%
R672	308-0366-00		3.4 k $\Omega$	3 W	WW	1%
R673	315-0101-00		100 $\Omega$	1/4 W		5%
R674	308-0294-00		8 k $\Omega$	3 W	WW	5%
R676	301-0363-00		36 k $\Omega$	1/2 W		5%
R678	315-0101-00		100 $\Omega$	1/4 W		5%
R679	308-0294-00		8 k $\Omega$	3 W	WW	5%
R680	315-0101-00		100 $\Omega$	1/4 W		5%
R681	308-0293-00		4 k $\Omega$	3 W	WW	5%
R682	315-0103-00		10 k $\Omega$	1/4 W		5%
R683	301-0101-00		100 $\Omega$	1/2 W		5%
R684	301-0182-00		1.8 k $\Omega$	1/2 W		5%
R685	323-0298-00		12.4 k $\Omega$	1/2 W	Prec	1%
R686	323-0316-00		19.1 k $\Omega$	1/2 W	Prec	1%
R689	301-0163-00		16 k $\Omega$	1/2 W		5%
R691	308-0231-00		220 $\Omega$	3 W	WW	5%
R699	315-0223-00		22 k $\Omega$	1/4 W		5%

**Electrical Parts List—Type 3A3**

**Switches**

Ckt. No.	Tektronix Part No.	Serial/Model No. Eff	No. Disc	Description
Unwired or Wired				
SW101	260-0600-00		Lever	CH 1 (+) AC GND DC
SW105	wired *262-0623-03		Rotary	CH 1 VOLTS/DIV
SW105	260-0590-01		Rotary	CH 1 VOLTS/DIV
SW201	260-0600-00		Lever	CH 1 (—) AC GND DC
SW261	260-0552-00		Reed	
SW301	260-0600-00		Lever	CH 2 (+) AC GND DC
SW305	wired *262-0627-03		Rotary	CH 2 VOLTS/DIV
SW305	260-0590-01		Rotary	CH 2 VOLTS/DIV
SW401	260-0600-00		Lever	CH 2 (—) AC GND DC
SW461	260-0552-00		Reed	
SW462	260-0407-00		Toggle	BANDWIDTH
SW570 } SW620 }	wired *262-0624-00		Rotary	TRIGGER MODE
SW570 } SW620 }	260-0589-00		Rotary	TRIGGER MODE

**Transformer**

T621	*120-0334-00		Toroid, 7 turns bifilar
------	--------------	--	-------------------------

**Electron Tubes**

V583	154-0187-00		6DJ8
V674	154-0340-00		7119



**INDEX OF MECHANICAL PARTS LIST ILLUSTRATIONS**  
(Located behind diagrams)

FIG. 1 EXPLODED VIEW

FIG. 2 STANDARD ACCESSORIES

## FIGURE AND INDEX NUMBERS

Items in this section are referenced by figure and index numbers to the illustrations which appear on the pullout pages immediately following the Diagrams section of this instruction manual.

## INDENTATION SYSTEM

This mechanical parts list is indented to indicate item relationships. Following is an example of the indentation system used in the Description column.

*Assembly and/or Component*  
*Detail Part of Assembly and/or Component*  
*mounting hardware for Detail Part*  
*Parts of Detail Part*  
*mounting hardware for Parts of Detail Part*  
*mounting hardware for Assembly and/or Component*

Mounting hardware always appears in the same indentation as the item it mounts, while the detail parts are indented to the right. Indented items are part of, and included with, the next higher indentation.

**Mounting hardware must be purchased separately, unless otherwise specified.**

## PARTS ORDERING INFORMATION

Replacement parts are available from or through your local Tektronix, Inc. Field Office or representative.

Changes to Tektronix instruments are sometimes made to accommodate improved components as they become available, and to give you the benefit of the latest circuit improvements developed in our engineering department. It is therefore important, when ordering parts, to include the following information in your order: Part number, instrument type or number, serial or model number, and modification number if applicable.

If a part you have ordered has been replaced with a new or improved part, your local Tektronix, Inc. Field Office or representative will contact you concerning any change in part number.

Change information, if any, is located at the rear of this manual.

## ABBREVIATIONS AND SYMBOLS

For an explanation of the abbreviations and symbols used in this section, please refer to the page immediately preceding the Electrical Parts List in this instruction manual.

# SECTION 8

## MECHANICAL PARTS LIST

FIG. 1 EXPLODED VIEW

Fig. & Index No.	Tektronix Part No.	Serial/Model Eff	No. Disc	Q					Description	
				y	1	2	3	4		5
1-1	333-0788-02			1						PANEL, front
-2	386-1351-00			1						PLATE, sub-panel
-3	366-0153-00			1						KNOB, charcoal—POSITION (CH 1)
	- - - - -			-						knob includes:
	213-0004-00			1						SCREW, set, 6-32 x 3/16 inch, HSS
-4	- - - - -			1						RESISTOR, variable
	- - - - -			-						mounting hardware: (not included w/resistor)
	210-0940-00			1						WASHER, flat, 1/4 ID x 3/8 inch OD
	210-0471-00			1						NUT, hex., 1/4-32 x 5/16 inch
-5	366-0153-00			1						KNOB, charcoal—POSITION (CH 2)
	- - - - -			-						knob includes:
	213-0004-00			1						SCREW, set, 6-32 x 3/16 inch, HSS
-6	- - - - -			1						RESISTOR, variable
	- - - - -			-						mounting hardware: (not included w/resistor)
	210-0940-00			1						WASHER, flat, 1/4 ID x 3/8 inch OD
	210-0471-00			1						NUT, hex., 1/4-32 x 5/16 inch
-7	366-0215-01			1						KNOB, charcoal—AC GND DC (+) (CH 1)
-8	260-0600-00			1						SWITCH, lever—AC GND DC (+) (CH 1)
	- - - - -			-						mounting hardware: (not included w/switch)
-9	220-0413-00			2						NUT, hex., 4-40 x 3/16 x 0.562 inch long
-10	366-0215-01			1						KNOB, charcoal—AC GND DC (-) (CH 1)
-11	260-0600-00			1						SWITCH, lever—AC GND DC (-) (CH 1)
	- - - - -			-						mounting hardware: (not included w/switch)
	220-0413-00			2						NUT, hex., 4-40 x 3/16 x 0.562 inch long
-12	366-0215-01			1						KNOB, charcoal—AC GND DC (+) (CH 2)
-13	260-0600-00			1						SWITCH, lever—AC GND DC (+) (CH 2)
	- - - - -			-						mounting hardware: (not included w/switch)
	220-0413-00			2						NUT, hex., 4-40 x 3/16 x 0.562 inch long
-14	366-0215-01			1						KNOB, charcoal—AC GND DC (-) (CH 2)
-15	260-0600-00			1						SWITCH, lever—AC GND DC (-) (CH 2)
	- - - - -			-						mounting hardware: (not included w/switch)
	220-0413-00			2						NUT, hex., 4-40 x 3/16 x 0.562 inch long
-16	366-0189-00			1						KNOB, red—CAL (CH 1)
	- - - - -			-						knob includes:
	213-0020-00			1						SCREW, set, 6-32 x 1/8 inch, HSS
-17	366-0322-00			1						KNOB, charcoal—VOLTS/DIV (CH 1)
	- - - - -			-						knob includes:
	213-0004-00			1						SCREW, set, 6-32 x 3/16 inch, HSS

FIG. 1 EXPLODED VIEW (cont)

Fig. & Index No.	Tektronix Part No.	Serial/Model Eff	No. Disc	Q					Description
				y	1	2	3	4	
1-18	262-0623-03			1					SWITCH, wired—VOLTS/DIV (CH 1)
	- - - - -			-					switch includes:
	260-0590-01			1					SWITCH, unwired
-19	- - - - -			1					RESISTOR, variable
	- - - - -			-					resistor includes:
	213-0022-00			1					SCREW, set, 4-40 x 3/16 inch, HSS
	384-0306-00			1					ROD, extension, 1/8 OD x 9 1/2 inches long
	- - - - -			-					mounting hardware: (not included w/resistor)
-20	210-0406-00			2					NUT, hex., 4-40 x 3/16 inch
	210-0004-00			2					LOCKWASHER, internal, #4
-21	166-0026-00			2					TUBE, spacer, 3/16 OD x 3/8 inch long
-22	211-0016-00			2					SCREW, 4-40 x 5/8 inch, PHS
-23	385-0111-00			2					ROD, plastic, 1/4 OD x 5/8 inch long
-24	352-0071-00			6					HOLDER, circuit board
-25	670-0046-02			1					ASSEMBLY, circuit board—VOLTS/DIV (CH 1)
	- - - - -			-					assembly includes:
	388-0572-00			1					BOARD, circuit
	- - - - -			-					board includes:
	388-0572-02			1					BOARD, circuit
-26	131-0505-00			4					TERMINAL, stud
	- - - - -			-					mounting hardware: (not included w/assembly)
-27	211-0008-00			6					SCREW, 4-40 x 1/4 inch, PHS
	- - - - -			-					mounting hardware: (not included w/switch)
-28	211-0007-00			2					SCREW, 4-40 x 3/16 inch, PHS
-29	210-0012-00			1					LOCKWASHER, internal, 3/8 ID x 1/2 inch OD
	210-0940-00			1					WASHER, flat, 1/4 ID x 3/8 inch OD
-30	210-0583-00			1					NUT, hex., 1/4-32 x 5/16 inch
-31	366-0189-00			1					KNOB, red—TRIGGER
	- - - - -			-					knob includes:
	213-0020-00			1					SCREW, set, 6-32 x 1/8 inch, HSS
-32	366-0322-00			1					KNOB, charcoal—MODE
	- - - - -			-					knob includes:
	213-0004-00			1					SCREW, set, 6-32 x 3/16 inch, HSS
-33	262-0624-00			1					SWITCH, wired—MODE
	- - - - -			-					switch includes:
	260-0589-00			1					SWITCH, unwired
	- - - - -			-					mounting hardware: (not included w/switch)
-34	337-0611-00			1					SHIELD, mode switch
	210-0840-00			1					WASHER, flat, 0.390 ID x 9/16 inch OD
-35	210-0413-00			2					NUT, hex., 3/8-32 x 1/2 inch
-36	358-0029-00			1					BUSHING, hex., 3/8-32 x 13/32 inch
-37	366-0189-00			1					KNOB, red—CAL (CH 2)
	- - - - -			-					knob includes:
	213-0020-00			1					SCREW, set, 6-32 x 1/8 inch, HSS
-38	366-0322-00			1					KNOB, charcoal—VOLTS/DIV (CH 2)
	- - - - -			-					knob includes:
	213-0004-00			1					SCREW, set, 6-32 x 3/16 inch, HSS

FIG. 1 EXPLODED VIEW (cont)

Fig. & Index No.	Tektronix Part No.	Serial/Model Eff	No. Disc	Q					Description
				y	1	2	3	4	
1-39	262-0627-03			1					SWITCH, wired—VOLTS/DIV (CH 2)
	- - - - -			-					switch includes:
	260-0590-01			1					SWITCH, unwired
-40	- - - - -			1					RESISTOR, variable
	- - - - -			-					resistor includes:
	213-0022-00			1					SCREW, set, 4-40 x 3/16 inch, HSS
	384-0306-00			1					ROD, extension, 1/8 OD x 9 1/2 inches long
	- - - - -			-					mounting hardware: (not included w/resistor)
-41	210-0406-00			2					NUT, hex., 4-40 x 3/16 inch
	210-0004-00			2					LOCKWASHER, internal, #4
-42	166-0026-00			2					TUBE, spacer, 3/16 OD x 3/8 inch long
-43	211-0016-00			2					SCREW, 4-40 x 5/8 inch, PHS
-44	385-0111-00			2					ROD, plastic, 1/4 OD x 5/8 inch long
-45	352-0071-00			6					HOLDER, circuit board
-46	670-0059-02			1					ASSEMBLY, circuit board—VOLTS/DIV (CH 2)
	- - - - -			-					assembly includes:
	388-0603-00			1					BOARD, circuit
	- - - - -			-					board includes:
	388-0603-02			1					BOARD, circuit
-47	131-0505-00			4					TERMINAL, stud
	- - - - -			-					mounting hardware: (not included w/assembly)
-48	211-0008-00			6					SCREW, 4-40 x 1/4 inch, PHS
	- - - - -			-					mounting hardware: (not included w/switch)
-49	211-0007-00			2					SCREW, 4-40 x 3/16 inch, PHS
-50	210-0012-00			1					LOCKWASHER, internal, 3/8 ID x 1/2 inch OD
	210-0940-00			1					WASHER, flat, 1/4 ID x 3/8 inch OD
-51	210-0583-00			1					NUT, hex., 1/4-32 x 5/16 inch
-52	260-0407-00			1					SWITCH, toggle—BANDWIDTH
	- - - - -			-					mounting hardware: (not included w/switch)
	210-0046-00			1					LOCKWASHER, internal, 0.261 ID x 0.400 inch OD
	210-0940-00			1					WASHER, flat, 1/4 ID x 3/8 inch OD
-53	210-0562-00			1					NUT, hex., 1/4-40 x 5/16 inch
	129-0053-00			2					ASSEMBLY, binding post
	- - - - -			-					each assembly includes:
-54	200-0103-00			1					CAP, binding post
-55	355-0507-00			1					STEM, binding post
	- - - - -			-					mounting hardware for each: (not included w/assembly)
	210-0223-00			1					LUG, solder, 1/4 ID x 7/16 inch OD, SE
-56	210-0455-00			1					NUT, hex., 1/4-28 x 3/8 inch

Mechanical Parts List—Type 3A3

FIG. 1 EXPLODED VIEW (cont)

Fig. & Index No.	Tektronix Part No.	Serial/Model Eff	No. Disc	Q					Description	
				t	y	1	2	3		4
1-57	131-0274-00			4						CONNECTOR, coaxial, 1 contact, BNC, w/hardware
-58	- - - - -			2						RESISTOR, variable
	- - - - -			-						mounting hardware for each: (not included w/resistor)
	210-0046-00			1						LOCKWASHER, internal, 0.261 ID x 0.400 inch OD
-59	210-0471-00			1						NUT, hex., 1/4-32 x 5/16 x 1 1/32 inch long
-60	358-0054-00			1						BUSHING, banana-jack
-61	- - - - -			1						RESISTOR, variable
	- - - - -			-						mounting hardware: (not included w/resistor)
-62	210-0046-00			1						LOCKWASHER, internal, 0.261 ID x 0.400 inch OD
	210-0471-00			1						NUT, hex., 1/4-32 x 5/16 x 1 1/32 inch long
-63	337-0613-00			1						SHIELD, cross talk
-64	358-0054-00			1						BUSHING, banana-jack
-65	366-0109-00			1						KNOB, plug-in securing
	- - - - -			-						knob includes:
	213-0005-00			1						SCREW, set, 8-32 x 1/8 inch, HSS
-66	214-0052-00			1						FASTENER, pawl right, w/stop
	- - - - -			-						mounting hardware: (not included w/fastener)
	210-0004-00			2						LOCKWASHER, internal, #4
	210-0406-00			2						NUT, hex., 4-40 x 3/16 inch
-67	337-0995-00			1						SHIELD, electron static
	- - - - -			-						mounting hardware: (not included w/shield)
	210-0457-00			2						NUT, keps, 6-32 x 5/16 inch
-68	406-0967-00			1						BRACKET, switch mounting
	- - - - -			-						mounting hardware: (not included w/bracket)
	211-0504-00			3						SCREW, 6-32 x 1/4 inch, PHS
-69	441-0769-00			1						CHASSIS
	- - - - -			-						mounting hardware: (not included w/chassis)
-70	211-0541-00			2						SCREW, 6-32 x 1/4 inch, 100° csk, FHS
-71	211-0597-00			2						SCREW, 6-32 x 1/4 inch, RHS
-72	214-0276-00			1						SPRING, ground
-73	211-0507-00			3						SCREW, 6-32 x 5/16 inch, PHS
-74	136-0181-00			7						SOCKET, transistor, 3 pin
	- - - - -			-						mounting hardware for each: (not included w/socket)
	354-0234-00			1						RING, socket mounting
-75	136-0218-00			24						SOCKET, transistor, 3 pin
	- - - - -			-						mounting hardware for each: (not included w/socket)
	354-0285-00			1						RING, socket mounting

FIG. 1 EXPLODED VIEW (cont)

Fig. & Index No.	Tektronix Part No.	Serial/Model Eff	No. Disc	Q					Description
				Y	1	2	3	4	
1-76	136-0235-00			2					SOCKET, transistor, 6 pin
	- - - - -			-					mounting hardware for each: (not included w/socket)
	354-0234-00			1					RING, socket mounting
-77	- - - - -			1					RESISTOR, variable
	- - - - -			-					mounting hardware: (not included w/resistor)
-78	210-0223-00			1					LUG, solder, 1/4 ID x 7/16 inch OD, SE
	210-0940-00			1					WASHER, flat, 1/4 ID x 3/8 inch OD
-79	210-0583-00			1					NUT, hex., 1/4-32 x 5/16 inch
-80	- - - - -			8					RESISTOR, variable
	- - - - -			-					mounting hardware for each: (not included w/resistor)
	210-0940-00			1					WASHER, flat, 1/4 ID x 3/8 inch OD
-81	210-0583-00			1					NUT, hex., 1/4-32 x 5/16 inch
-82	136-0072-00			2					SOCKET, tube, 9 pin
	- - - - -			-					mounting hardware for each: (not included w/socket)
	213-0044-00			2					SCREW, thread forming, 5-32 x 3/16 inch, PHS
-83	426-0225-00			6					MOUNT, capacitor, plastic
-84	354-0068-00			4					RING, securing, plastic
-85	348-0031-00			14					GROMMET, plastic, 3/32 inch diameter
-86	348-0055-00			4					GROMMET, plastic, 1/4 inch diameter
-87	348-0056-00			3					GROMMET, plastic, 3/8 inch diameter
-88	348-0063-00			1					GROMMET, plastic, 1/2 inch diameter
-89	210-0259-00			20					LUG, solder, #2
	- - - - -			-					mounting hardware for each: (not included w/lug)
	213-0055-00			1					SCREW, thread forming, 2-32 x 3/16 inch, PHS
-90	131-0158-00			2					CONNECTOR, terminal, feed thru
-91	131-0157-00			4					CONNECTOR, terminal, stand off
-92	426-0121-00			1					MOUNT, toroid
	- - - - -			-					mounting hardware: (not included w/mount)
	361-0007-00			1					SPACER, plastic, 0.188 inch long
-93	344-0143-00			4					CLIP, circuit board mounting
	- - - - -			-					mounting hardware for each: (not included w/clip)
	213-0088-00			1					SCREW, thread forming, #4 x 1/4 inch, PHS

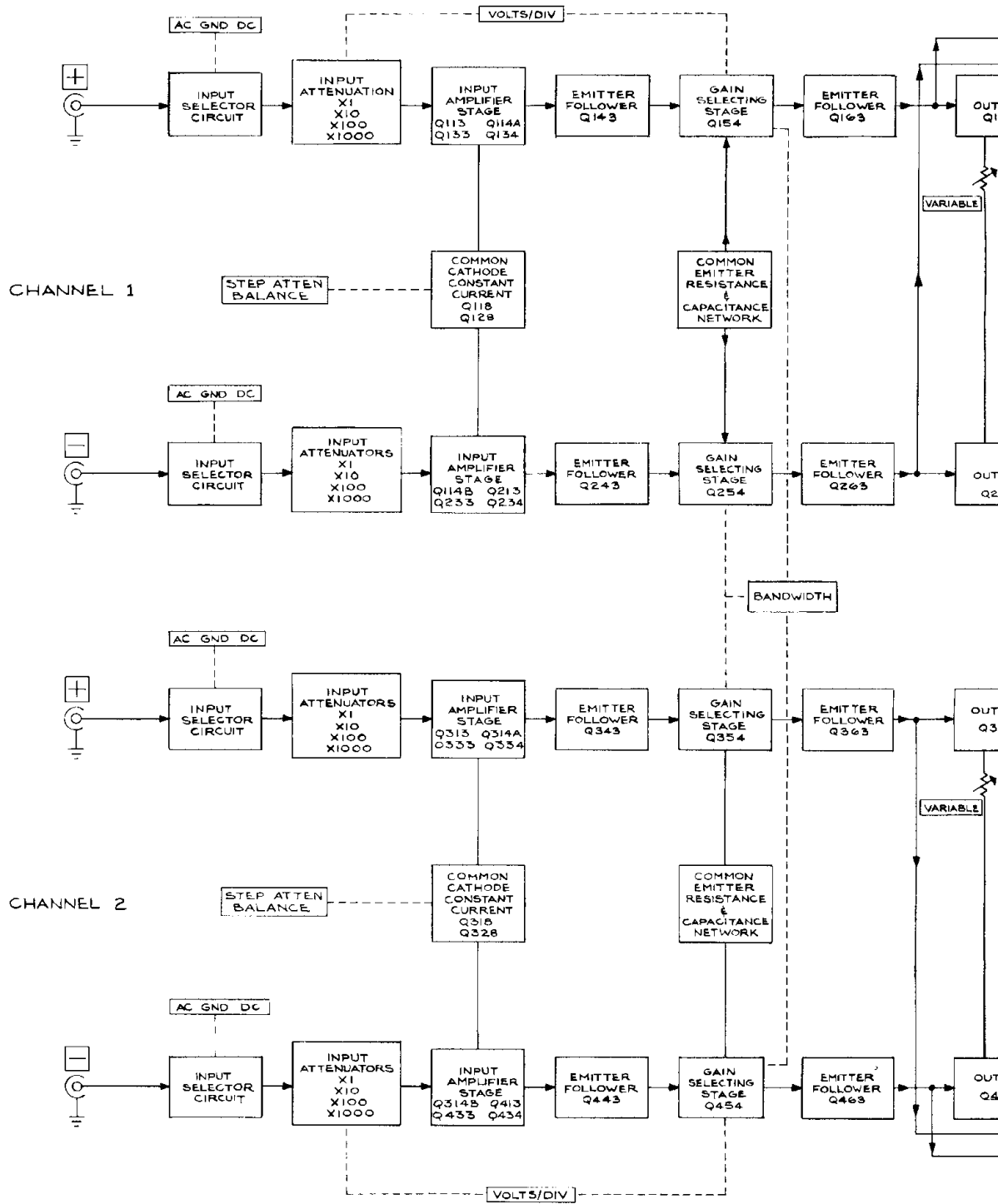
FIG. 1 EXPLODED VIEW (cont)

Fig. & Index No.	Tektronix Part No.	Serial/Model Eff	No. Disc	Q					Description
				†	1	2	3	4	
1-94	670-0177-00			1					ASSEMBLY, circuit board—INPUT AMPLIFIER
	- - - - -			-					assembly includes:
	388-0960-00			1					BOARD, circuit
-95	214-0506-00			23					PIN, connector
-96	136-0220-00			12					SOCKET, transistor, 3 pin
-97	136-0235-00			2					SOCKET, transistor, 6 pin
-98	200-0687-01			2					COVER, plastic
-99	337-0994-00			1					SHIELD
-100	200-0822-00			1					COVER, circuit board, plastic
-101	337-0612-01			1					SHIELD
	- - - - -			-					mounting hardware: (not included w/shield)
	211-0542-00			2					SCREW, 6-32 x 5/16 inch, THS
-102	361-0068-00			2					SPACER, shield, hex., 6-32 x 1/4 inch diameter
-103	384-0615-00			4					ROD, spacer
-104	351-0037-00			1					GUIDE, plug-in
	- - - - -			-					mounting hardware: (not included w/guide)
	211-0013-00			1					SCREW, 4-40 x 3/8 inch, RHS
	210-0004-00			1					LOCKWASHER, internal, #4
-105	210-0406-00			1					NUT, hex., 4-40 x 3/16 inch
-106	210-0202-00			1					LUG, solder, SE #6
	- - - - -			-					mounting hardware: (not included w/lug)
-107	211-0507-00			1					SCREW, 6-32 x 5/16 inch, PHS
	210-0407-00			1					NUT, hex., 6-32 x 1/4 inch
-108	131-0149-00			1					CONNECTOR, 24 contact, male
	- - - - -			-					mounting hardware: (not included w/connector)
-109	211-0008-00			2					SCREW, 4-40 x 1/4 inch, PHS
	210-0004-00			2					LOCKWASHER, internal, #4
	210-0406-00			2					NUT, hex., 4-40 x 3/16 inch
-110	214-0276-00			1					SPRING, ground
	- - - - -			-					mounting hardware: (not included w/spring)
	211-0507-00			1					SCREW, 6-32 x 5/16 inch, PHS
	210-0457-00			1					NUT, keps, 6-32 x 5/16 inch
-111	387-0647-00			1					PLATE, rear
	- - - - -			-					mounting hardware: (not included w/plate)
	212-0044-00			4					SCREW, 8-32 x 1/2 inch, RHS

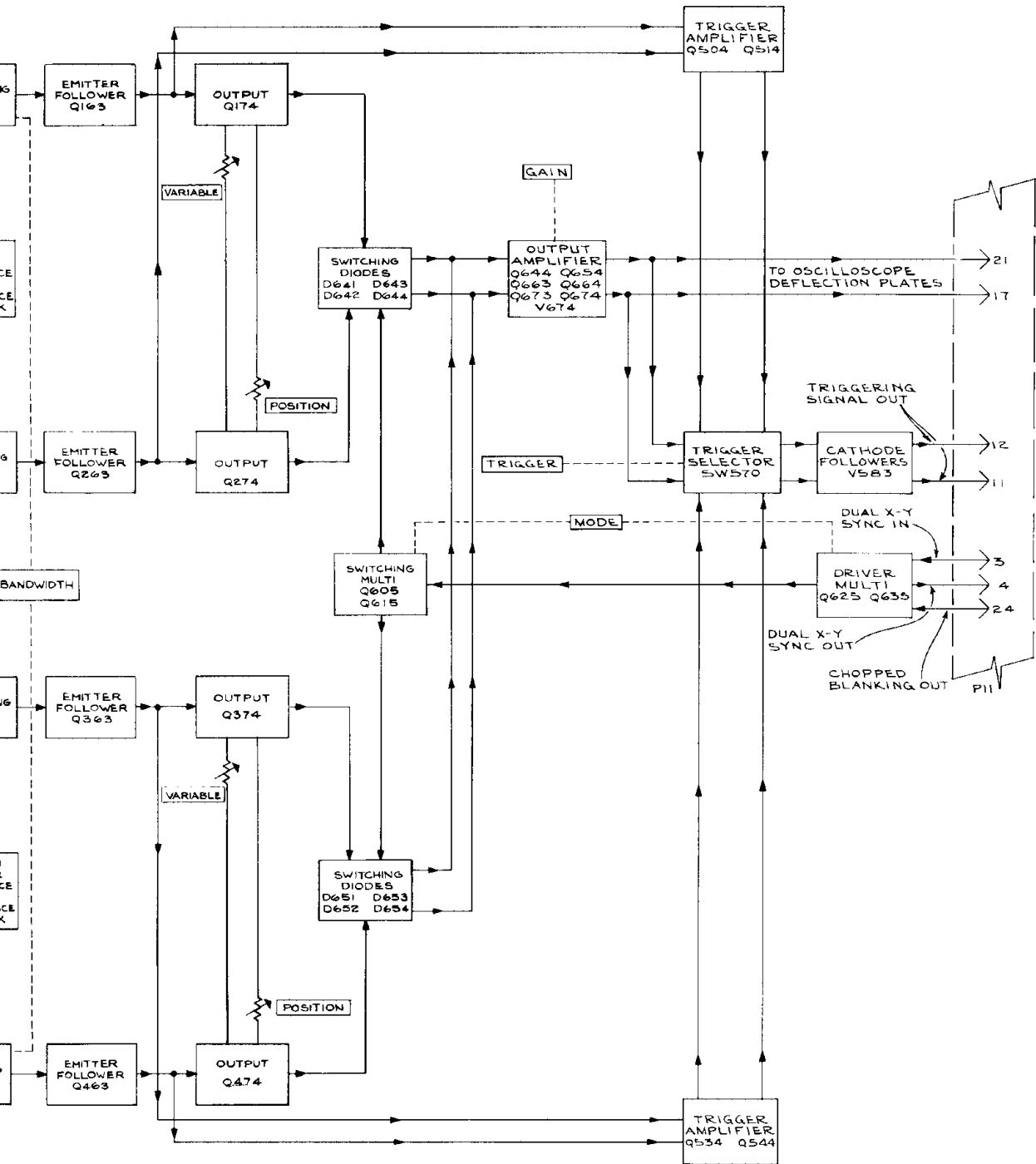


FIG. 1 EXPLODED VIEW (cont)

Fig. & Index No.	Tektronix Part No.	Serial/Model Eff	No. Disc	Q					Description	
				†	Y	1	2	3		4
1-112	179-0881-01			1						CABLE HARNESS, connector
-113	179-0888-00			1						CABLE HARNESS, trigger
-114	179-0853-03			1						CABLE HARNESS, chassis
	- - - - -			-						cable harness includes:
	131-0371-00			5						CONNECTOR, single contact
-115	179-1228-00			1						CABLE HARNESS, CHAN. 1
	- - - - -			-						cable harness includes:
	131-0371-00			5						CONNECTOR, single contact
-116	179-1227-00			1						CABLE HARNESS, CHAN. 2
	- - - - -			-						cable harness includes:
	131-0371-00			5						CONNECTOR, single contact
-117	124-0148-00			8						STRIP, ceramic, 7/16 inch h, w/9 notches
	- - - - -			-						each strip includes:
	355-0046-00			2						STUD, plastic
	- - - - -			-						mounting hardware for each: (not included w/strip)
	361-0009-00			2						SPACER, plastic, 0.406 inch long
-118	124-0146-00			2						STRIP, ceramic, 7/16 inch h, w/16 notches
	- - - - -			-						each strip includes:
	355-0046-00			2						STUD, plastic
	- - - - -			-						mounting hardware for each: (not included w/strip)
	361-0009-00			2						SPACER, plastic, 0.406 inch long
-119	124-0145-00			12						STRIP, ceramic, 7/16 inch h, w/20 notches
	- - - - -			-						each strip includes:
	355-0046-00			2						STUD, plastic
	- - - - -			-						mounting hardware for each: (not included w/strip)
	361-0009-00			2						SPACER, plastic, 0.406 inch long
-120	124-0162-00			4						STRIP, ceramic, 7/16 inch h, w/4 notches
	- - - - -			-						each strip includes:
	355-0046-00			1						STUD, plastic
	- - - - -			-						mounting hardware for each: (not included w/strip)
	361-0007-00			1						SPACER, plastic, 0.188 inch long

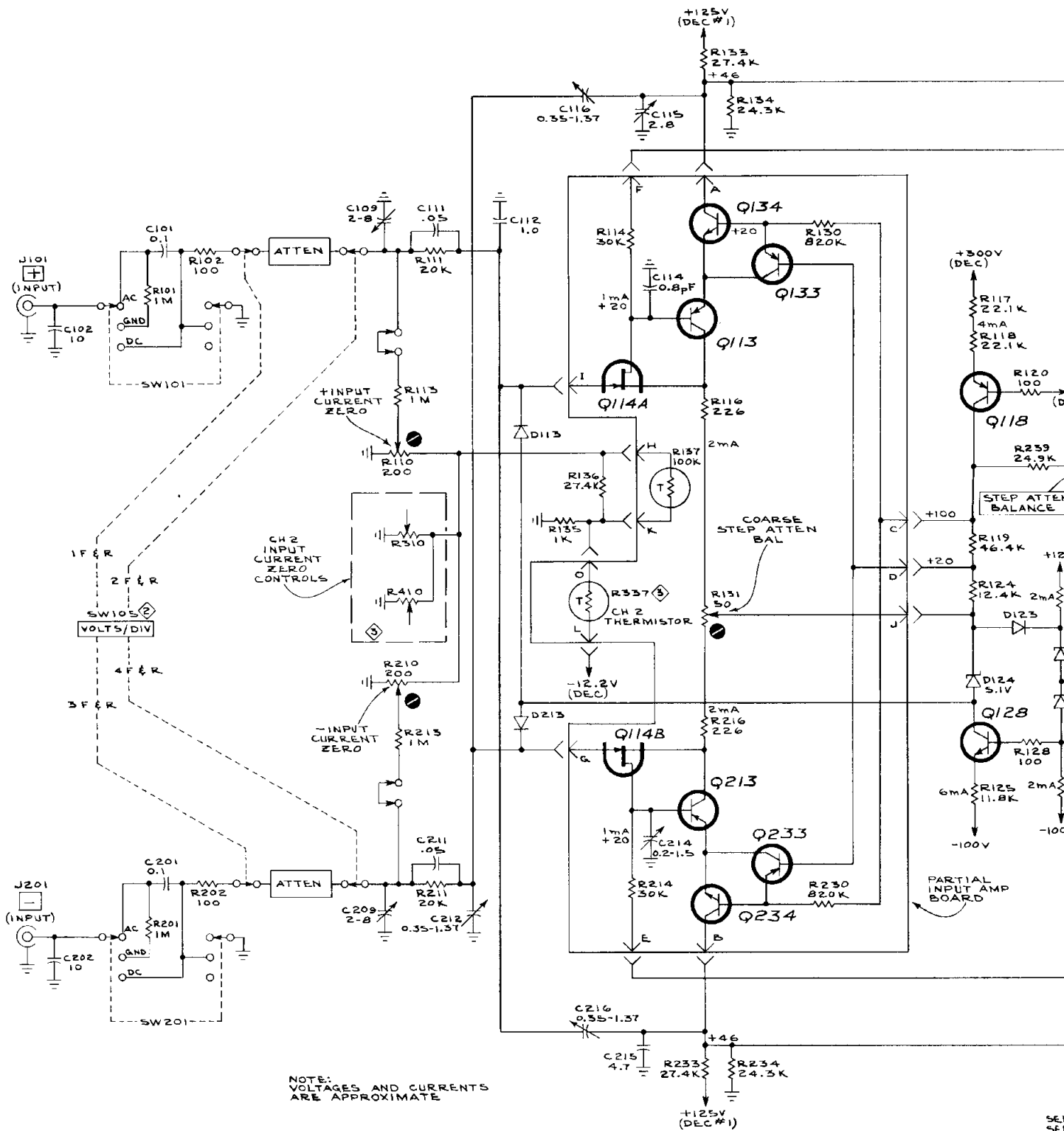


TYPE 3A3 PLUG-IN



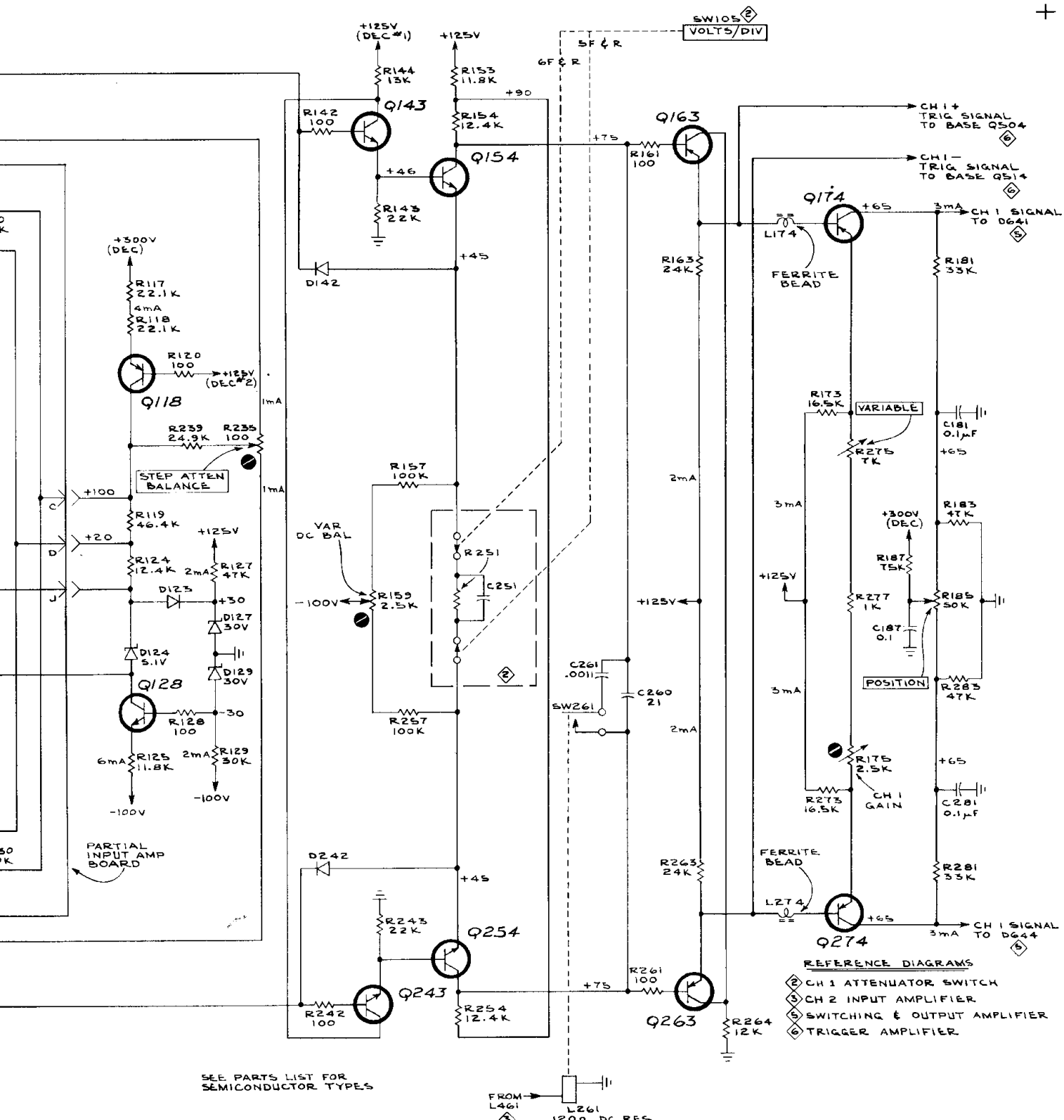
PLM  
268

BLOCK DIAGRAM  
(S/N4990-UP)



+

TYPE 3A3 PLUG-IN



SEE PARTS LIST FOR SEMICONDUCTOR TYPES

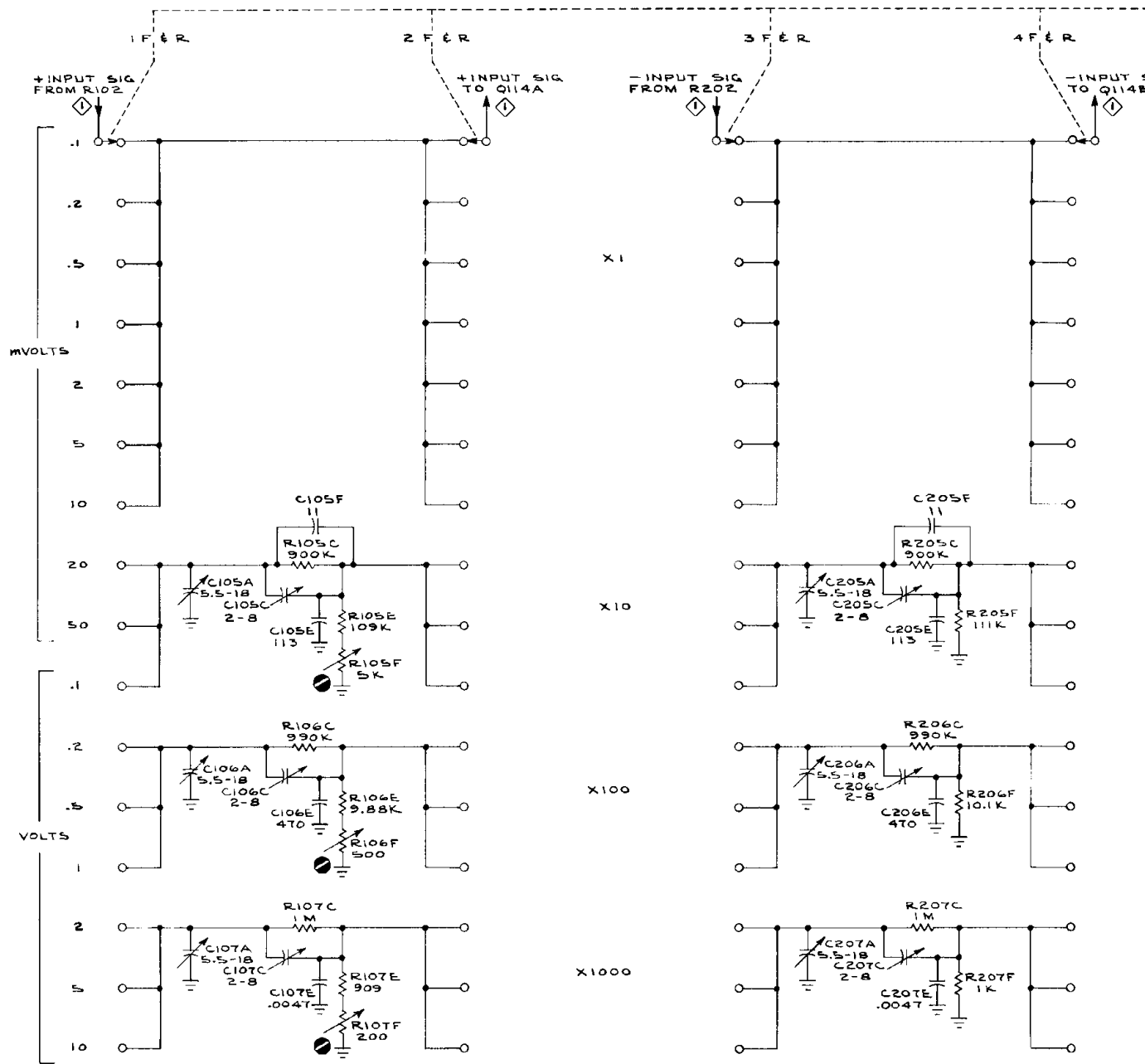
FROM L461  
LZ61  
120Ω DC RES

PLM  
268

### CH 1 INPUT AMPLIFIER

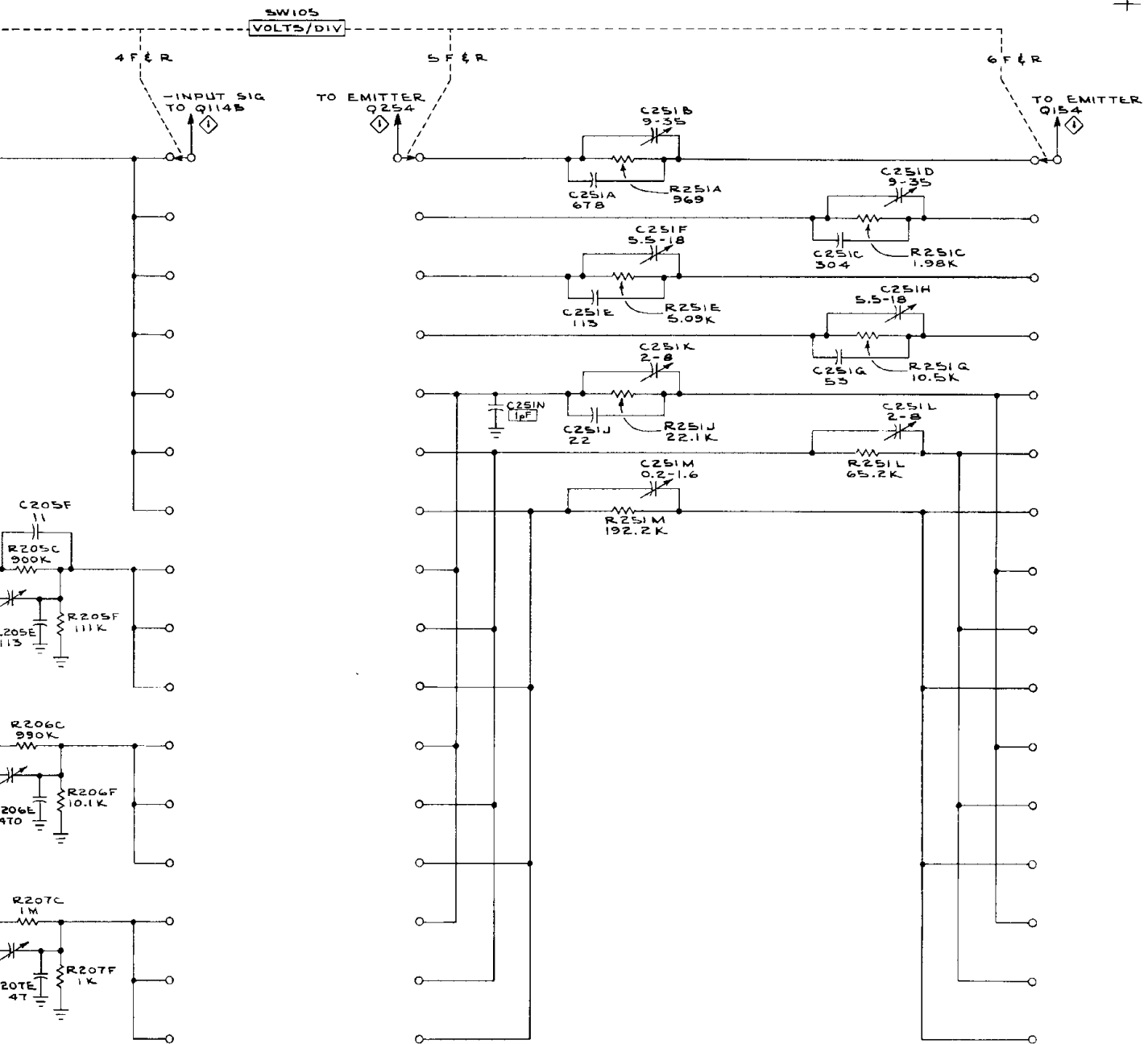
(S/N 4390-UP)

- REFERENCE DIAGRAMS**
- ② CH 1 ATTENUATOR SWITCH
  - ③ CH 2 INPUT AMPLIFIER
  - ④ SWITCHING & OUTPUT AMPLIFIER
  - ⑤ TRIGGER AMPLIFIER



REFERENCE DIAGRAM  
 CH1 INPUT AMPLIFIER

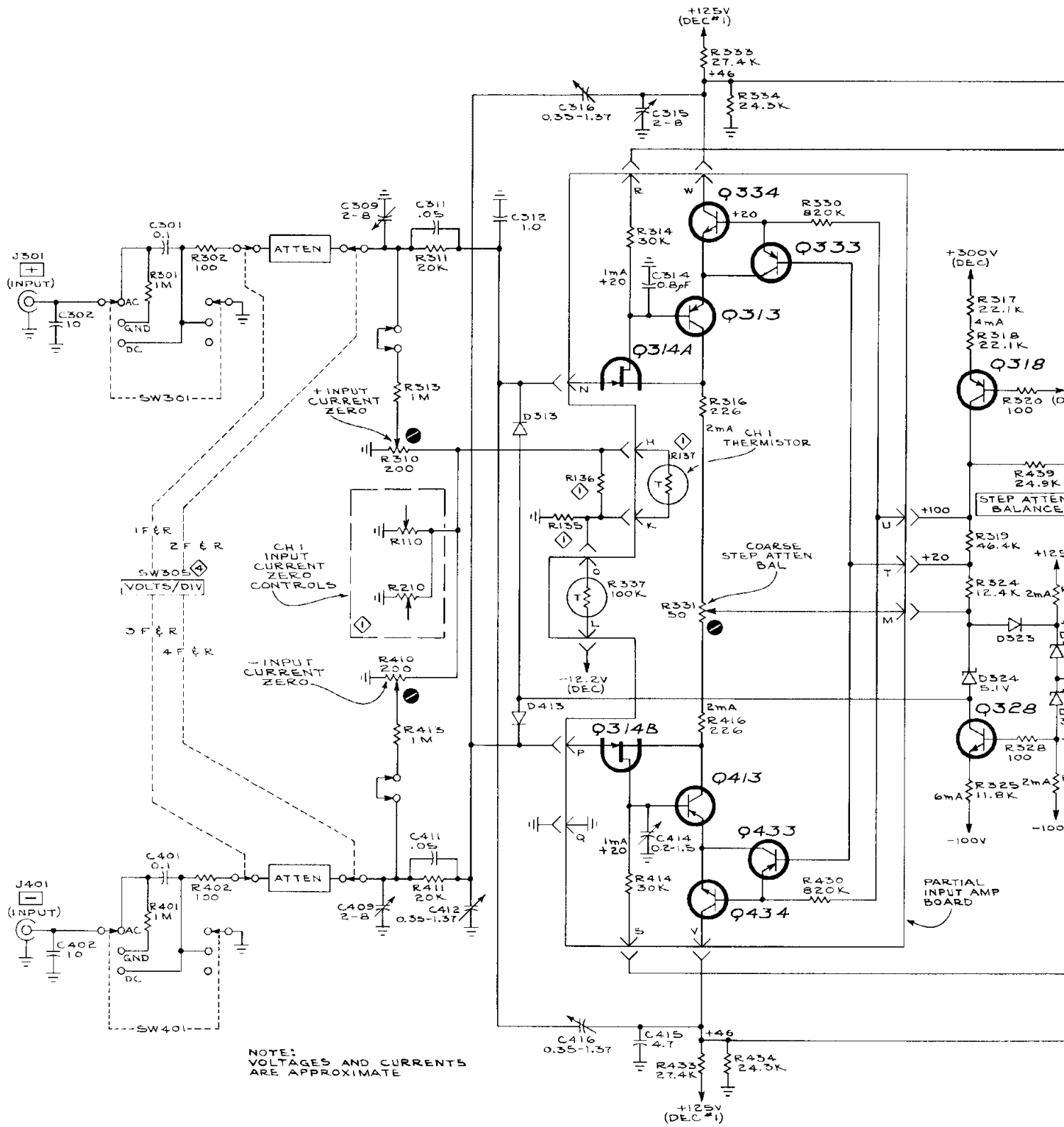
+ TYPE 3A3 PLUG-IN



SEE PARTS LIST FOR EARLIER  
VALUES AND SERIAL NUMBER  
RANGES OF PARTS MARKED  
WITH BLUE OUTLINE.

PLM  
568

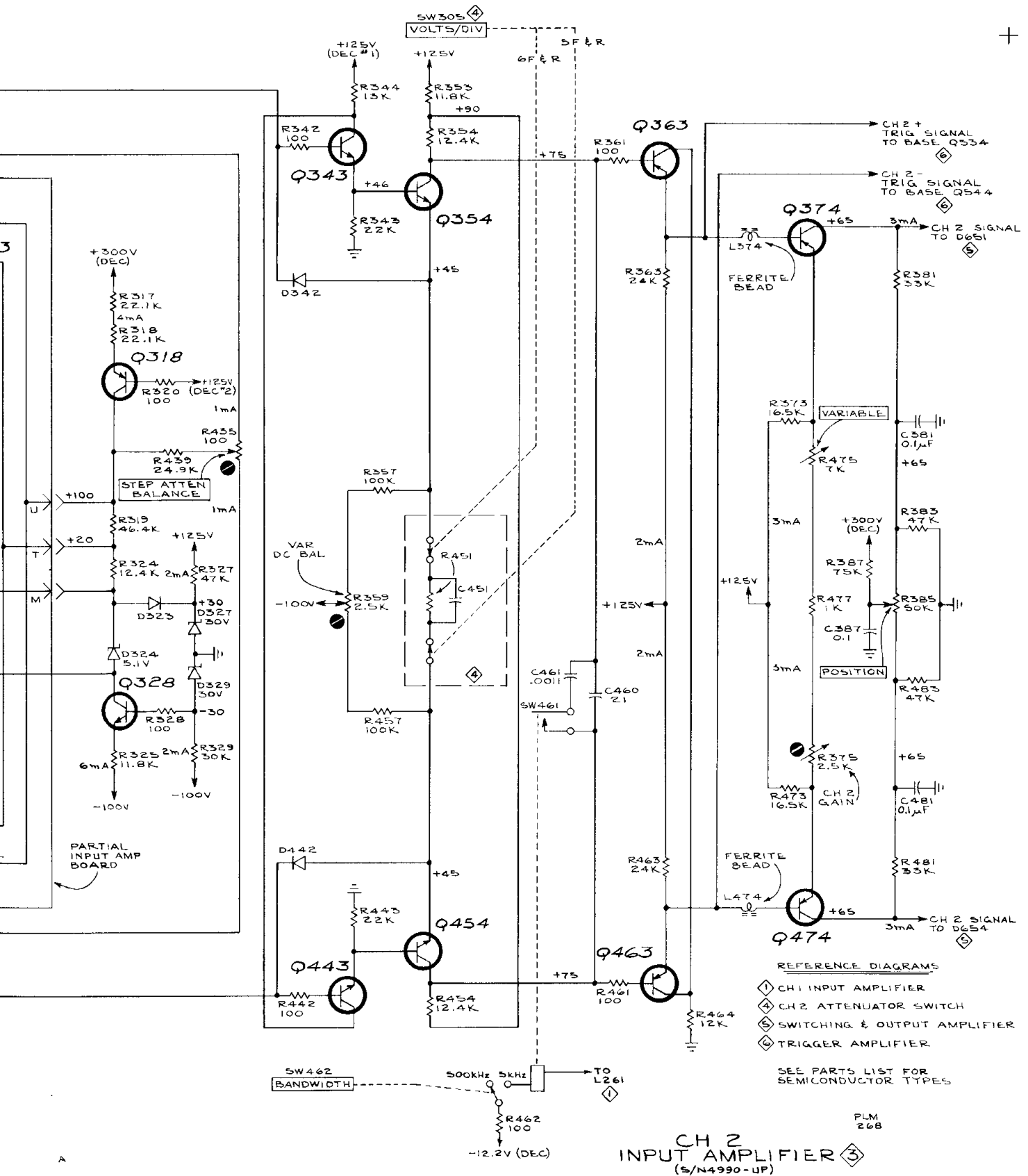
CH 1 ATTENUATOR SWITCH ②  
(S/N 4990-UP)



TYPE 3A3 PLUG-IN

A





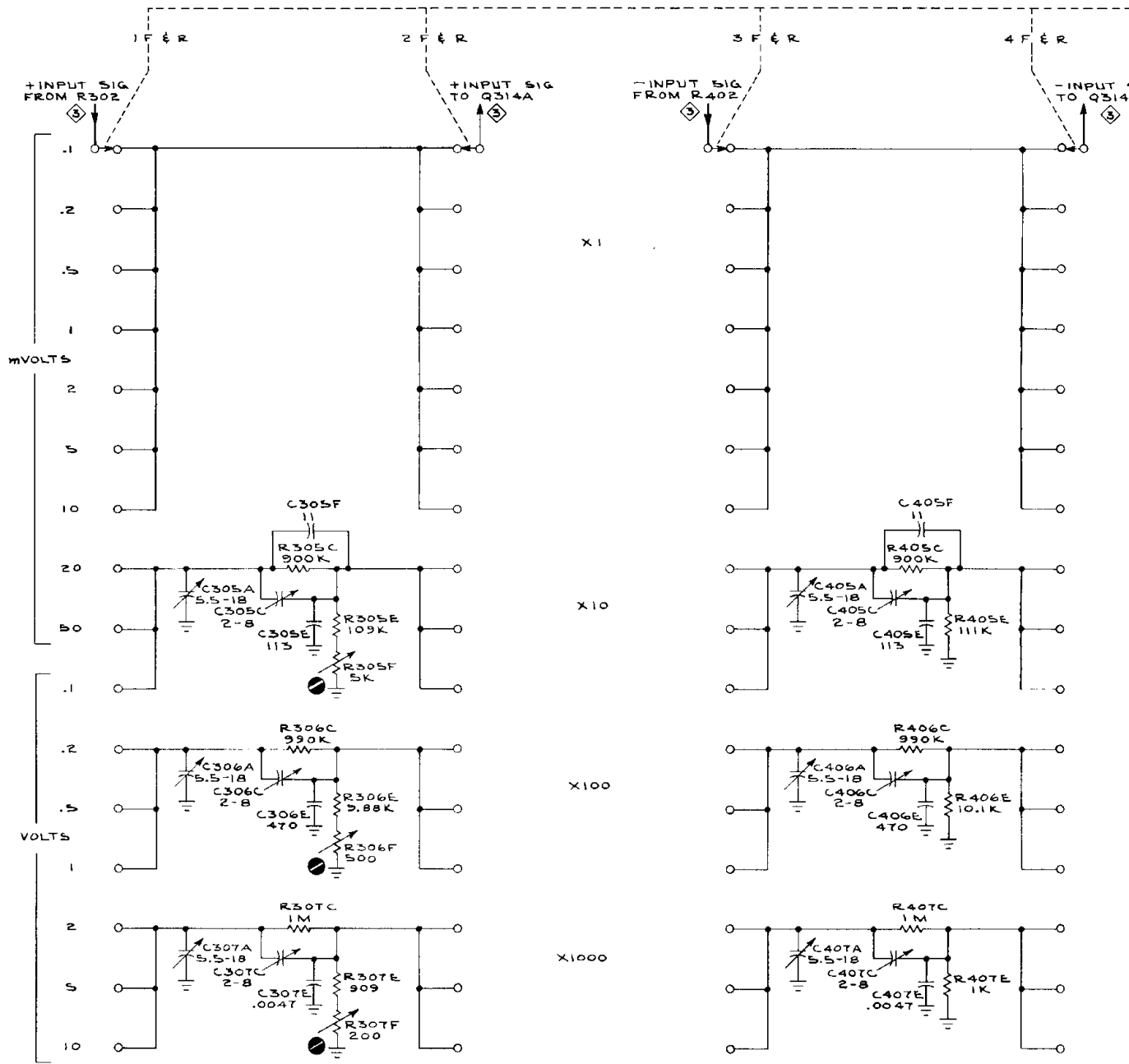
REFERENCE DIAGRAMS

- ① CH1 INPUT AMPLIFIER
- ② CH2 ATTENUATOR SWITCH
- ③ SWITCHING & OUTPUT AMPLIFIER
- ④ TRIGGER AMPLIFIER

SEE PARTS LIST FOR SEMICONDUCTOR TYPES

PLM 208

CH 2 INPUT AMPLIFIER ③  
(S/N4990-UP)

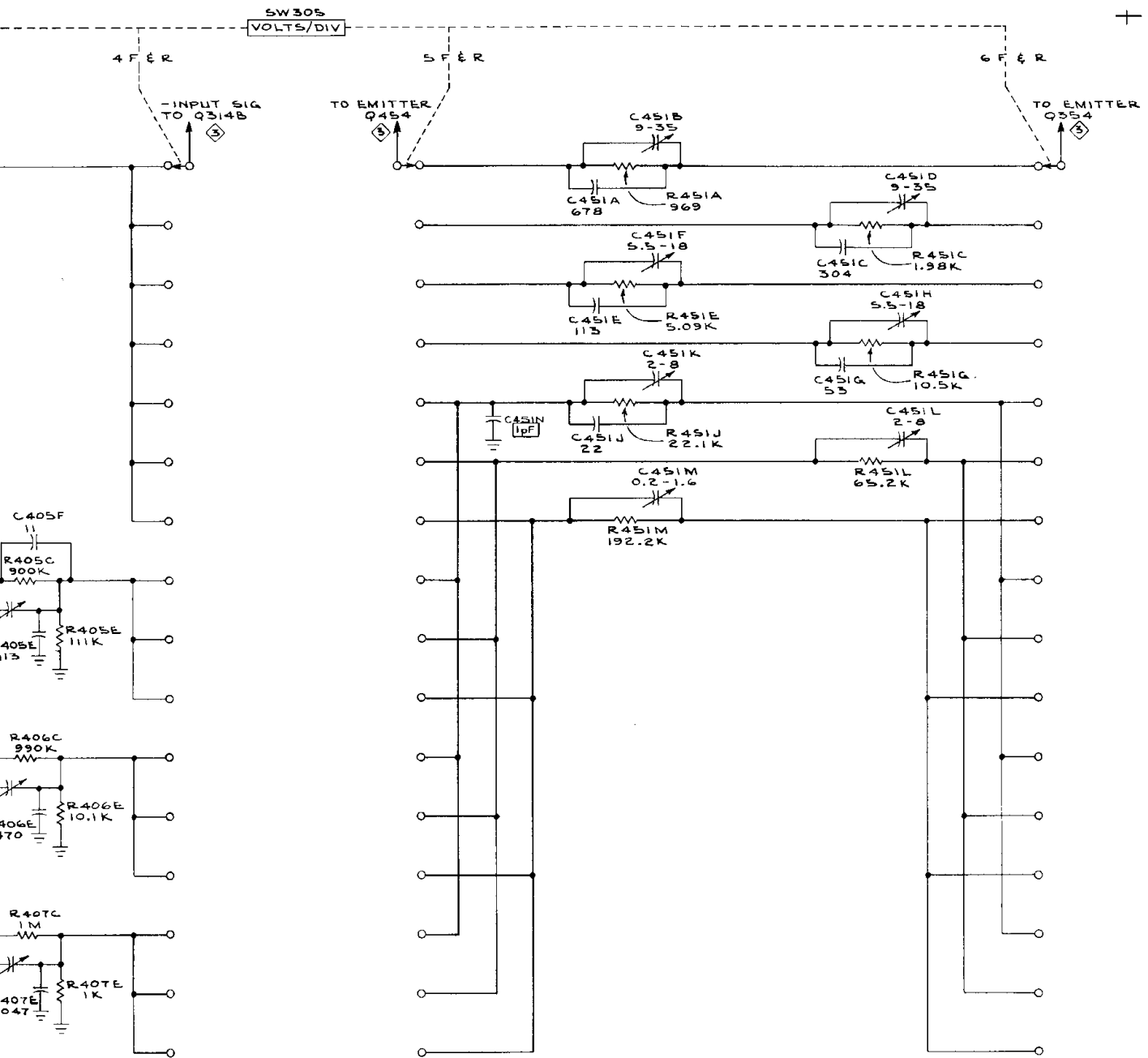


REFERENCE DIAGRAM

③ CH 2 INPUT AMPLIFIER

+

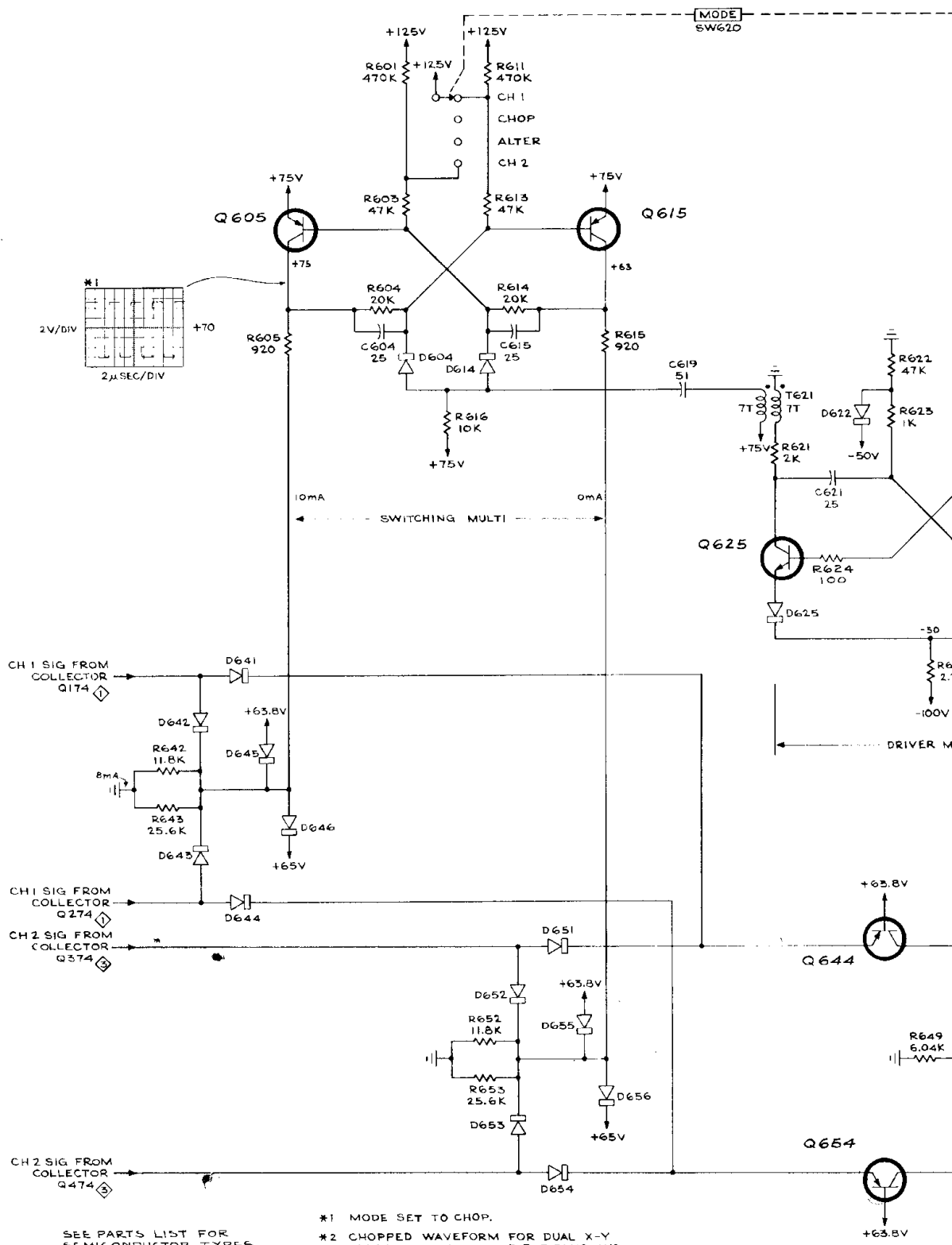
TYPE 3A3 PLUG-IN



SEE PARTS LIST FOR EARLIER  
VALUES AND SERIAL NUMBER  
RANGES OF PARTS MARKED  
WITH BLUE OUTLINE.

PLM  
56B

CH 2 ATTENUATOR SWITCH 4  
(S/N 4990-UP)



CH 1 SIG FROM COLLECTOR Q174

CH 1 SIG FROM COLLECTOR Q274

CH 2 SIG FROM COLLECTOR Q374

CH 2 SIG FROM COLLECTOR Q474

- \*1 MODE SET TO CHOP.
  - \*2 CHOPPED WAVEFORM FOR DUAL X-Y OPERATION, TWO TYPE 3A3 PLUG-INS WITH 2ND SET TO ALTER.
  - \*3 NEGATIVE-GOING GATE PULSE FROM TYPE 2B67, TYPE 3A3 MODE SET TO ALTER.
- SEE IMPORTANT NOTE ON TRIG. AMP DIAG.

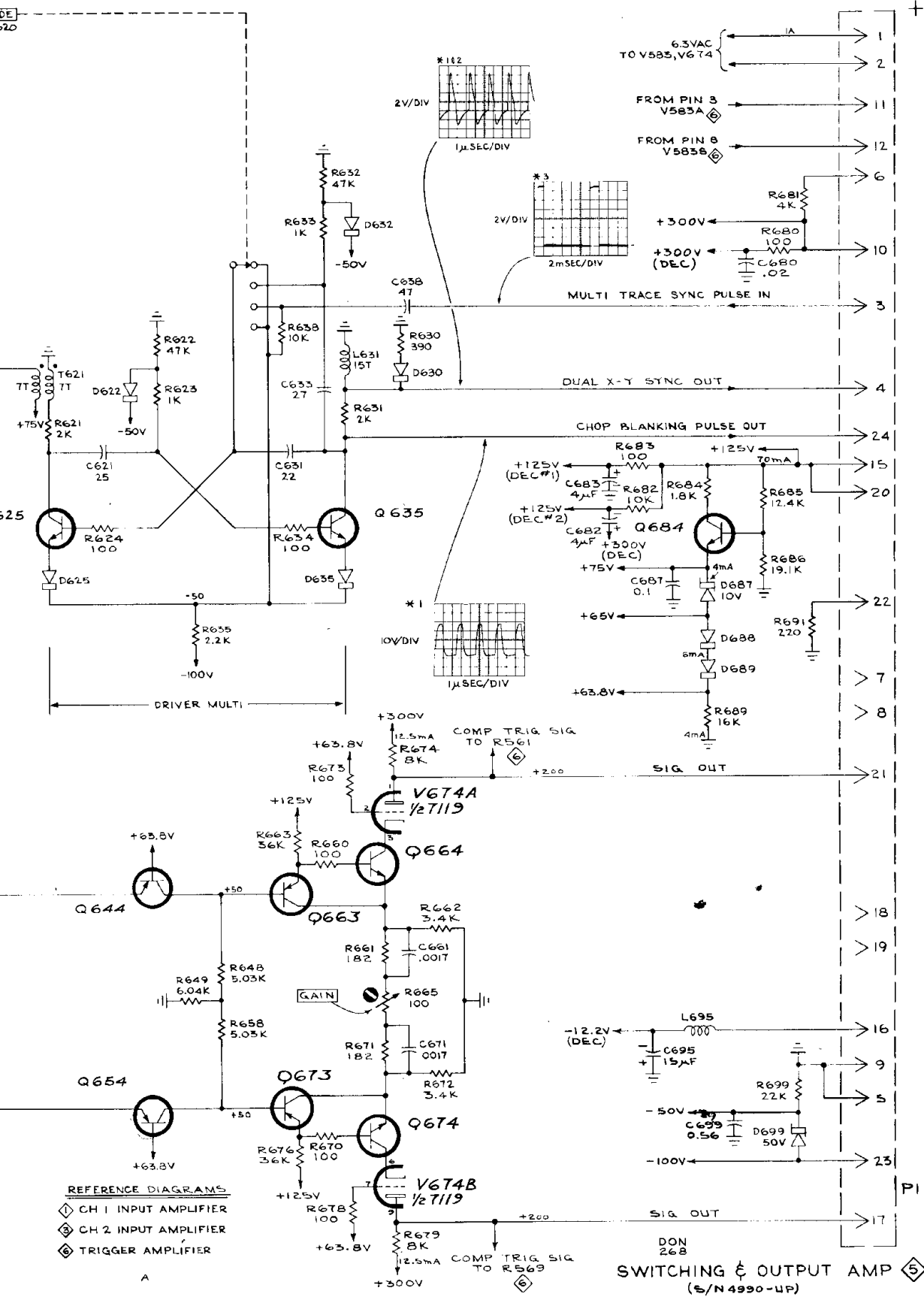
REFERENCE DIAGRAM

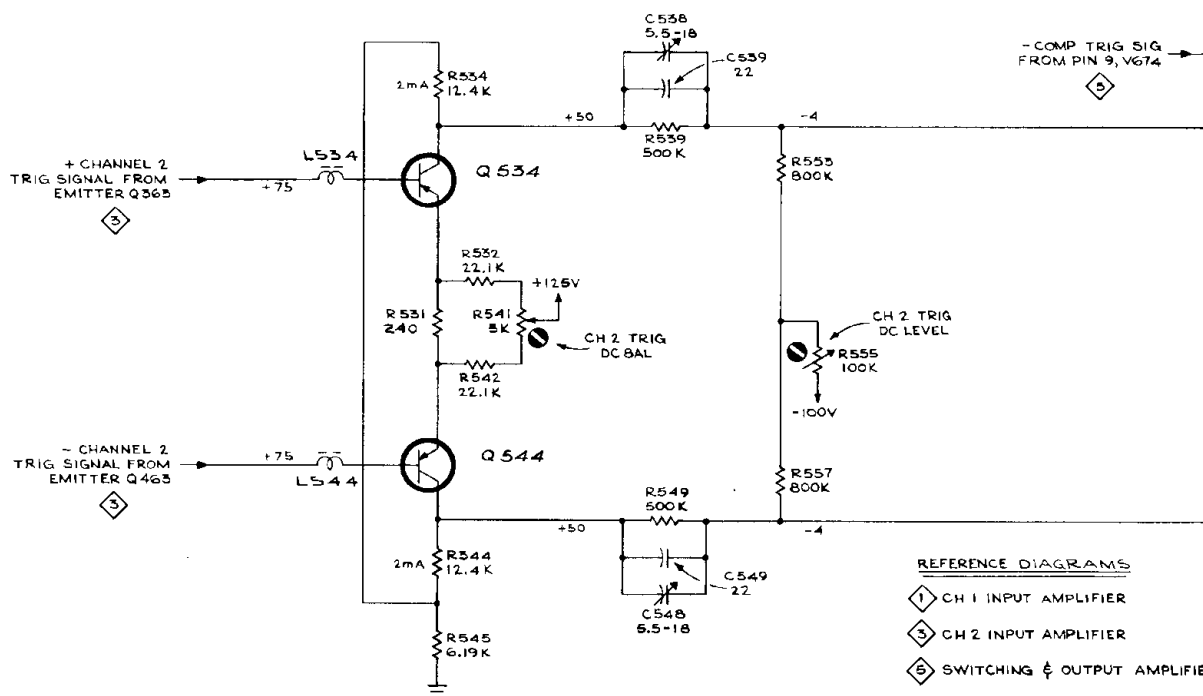
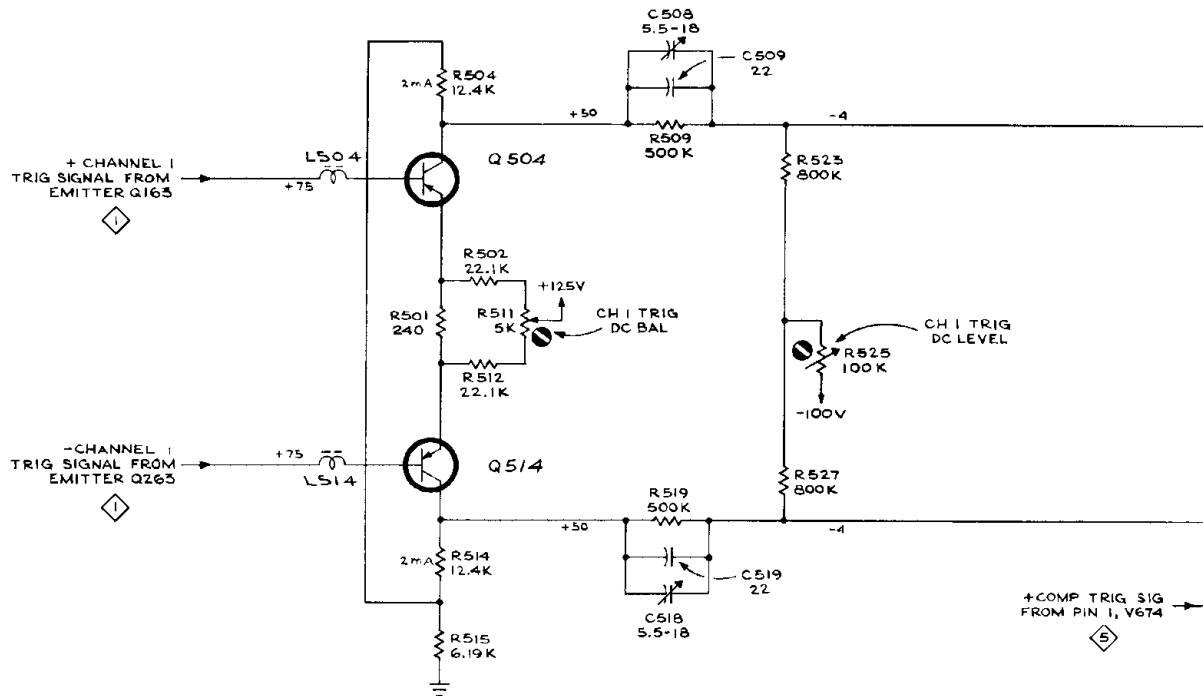
- ◇ CH 1 INPUT AMPLIFIER
- ◇ CH 2 INPUT AMPLIFIER
- ◇ TRIGGER AMPLIFIER

TYPE 3A3 PLUG-IN

+

A

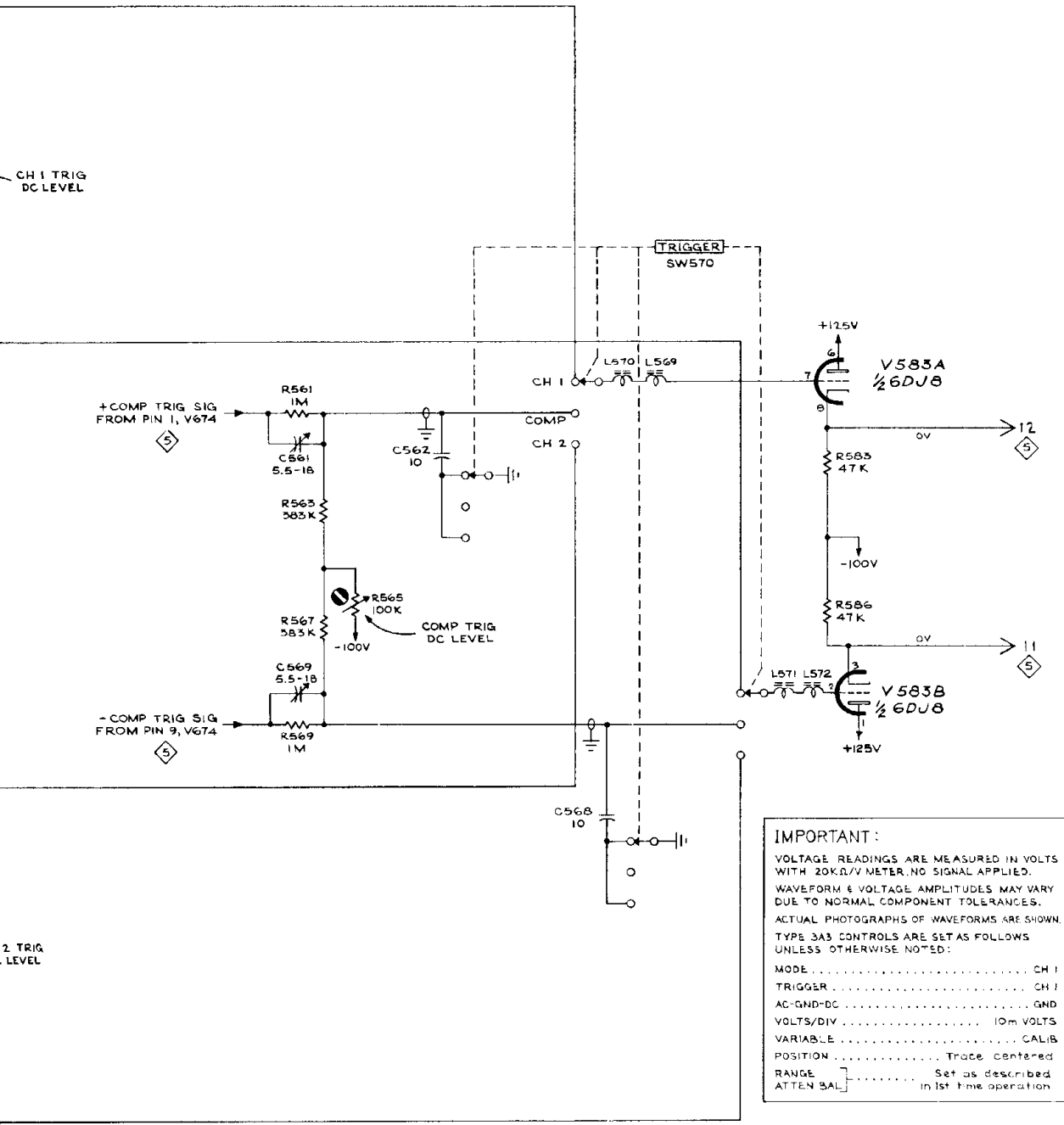




- REFERENCE DIAGRAMS
- ① CH 1 INPUT AMPLIFIER
  - ② CH 2 INPUT AMPLIFIER
  - ③ SWITCHING & OUTPUT AMPLIFIER

TYPE 3A3 PLUG-IN  
+

+



**IMPORTANT:**  
 VOLTAGE READINGS ARE MEASURED IN VOLTS WITH 20KΩ/V METER, NO SIGNAL APPLIED.  
 WAVEFORM & VOLTAGE AMPLITUDES MAY VARY DUE TO NORMAL COMPONENT TOLERANCES.  
 ACTUAL PHOTOGRAPHS OF WAVEFORMS ARE SHOWN.  
 TYPE 3A3 CONTROLS ARE SET AS FOLLOWS UNLESS OTHERWISE NOTED:

MODE	.....	CH 1
TRIGGER	.....	CH 1
AC-GND-DC	.....	GND
VOLTS/DIV	.....	10m VOLTS
VARIABLE	.....	CALIB
POSITION	.....	Trace centered
RANGE	.....	Set as described
ATTEN BAL	.....	in 1st time operation

REFERENCE DIAGRAMS

- ① CH 1 INPUT AMPLIFIER
- ⑤ CH 2 INPUT AMPLIFIER
- ⑥ SWITCHING & OUTPUT AMPLIFIER

SEE PARTS LIST FOR SEMICONDUCTOR TYPES

A<sub>1</sub>

TRIGGER AMPLIFIER ⑥ DON 268  
 (S/N 4990-UP)

FIG. 1 EXPLODED VIEW

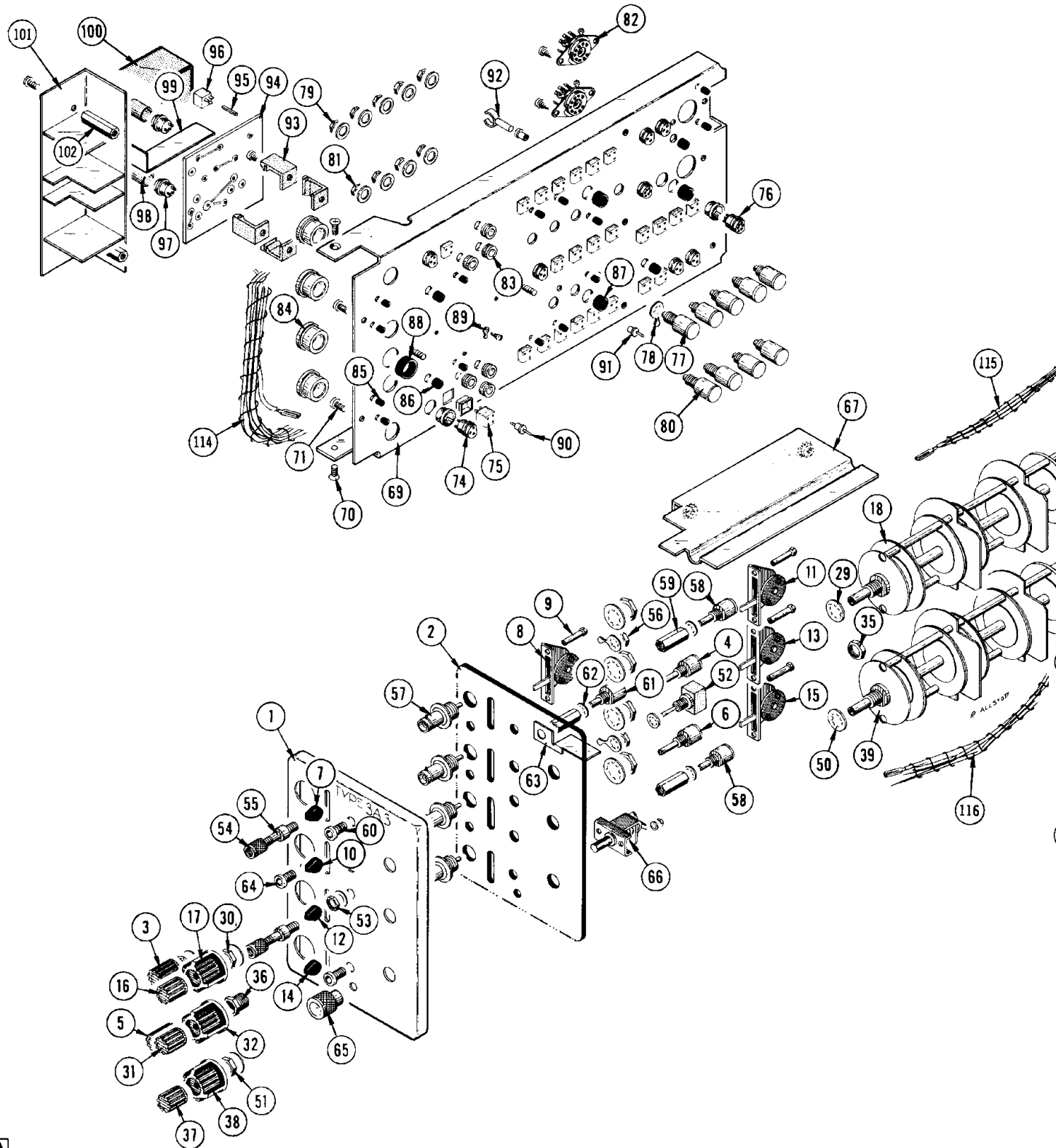
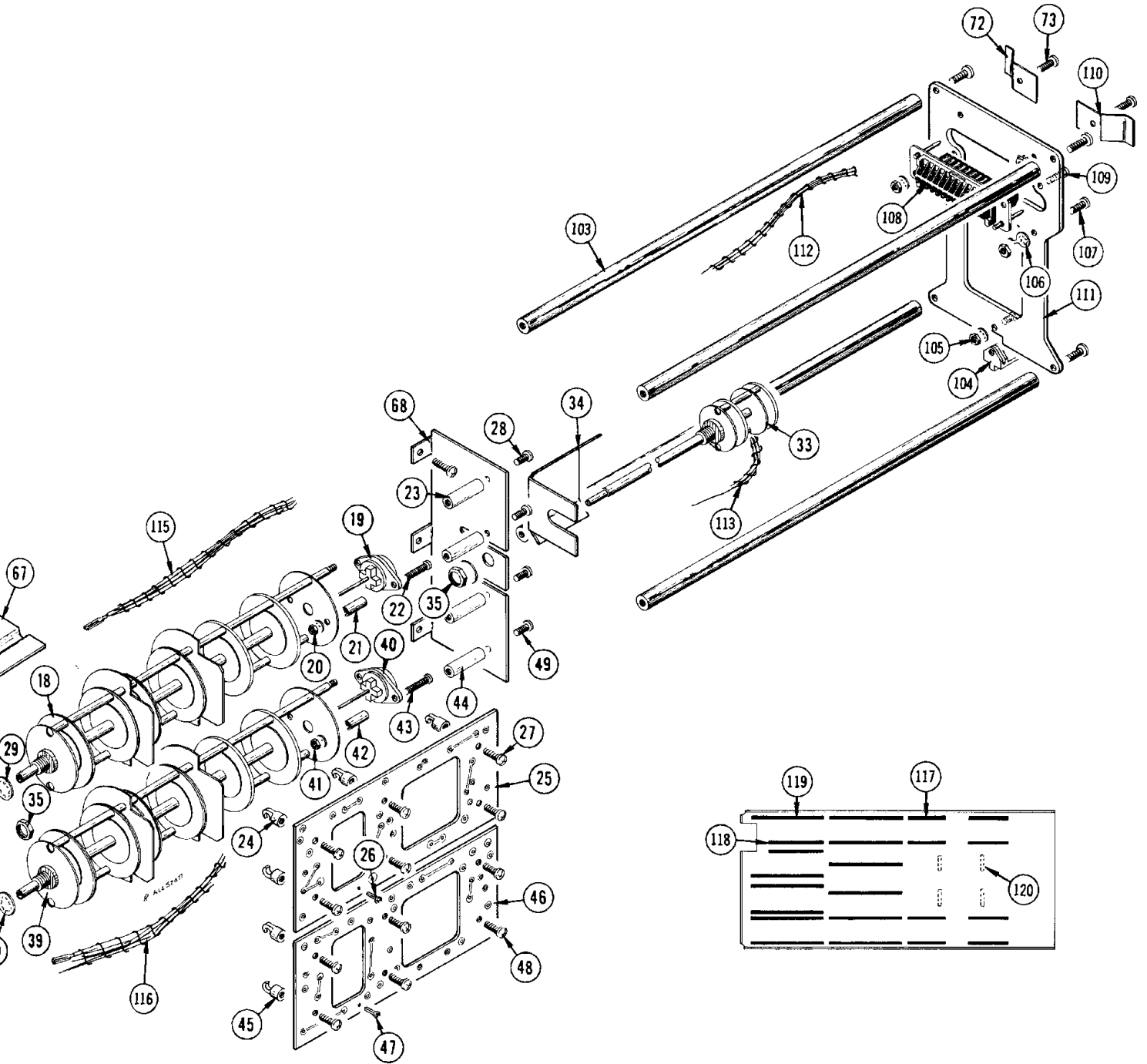




FIG. 1 EXPLODED VIEW

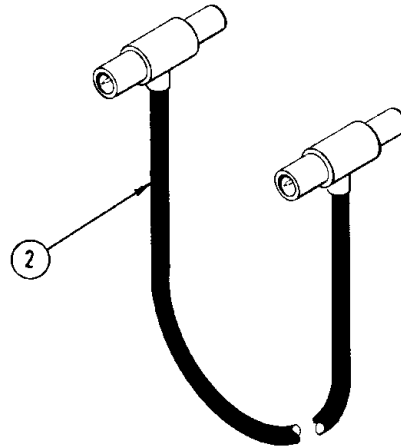
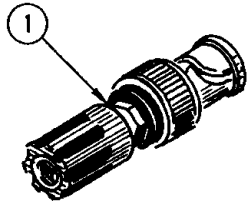
+



TYPE 3A3 DUAL TRACE DIFFERENTIAL AMPLIFIER

FIG. 2 STANDARD ACCESSORIES

+



+ **A**

Fig. & Index No.	Tektronix Part No.	Serial/Model No. Eff	No. Disc	Q					Description	
				t	y	1	2	3		4
2-1	103-0033-00			4						ADAPTER, BNC to binding post
-2	012-0087-00			2						CORD, patch, BNC to BNC, red, 18 inches long
	070-0787-00			2						MANUAL, instruction (not shown)

## **MANUAL CHANGE INFORMATION**

At Tektronix, we continually strive to keep up with latest electronic developments by adding circuit and component improvements to our instruments as soon as they are developed and tested.

Sometimes, due to printing and shipping requirements, we can't get these changes immediately into printed manuals. Hence, your manual may contain new change information on following pages. If it does not, your manual is correct as printed.

TYPE 3A3

TENT SN 6150

ELECTRICAL PARTS LIST CORRECTION

CHANGE TO:

SW462

260-0613-00

Toggle

BANDWIDTH

## ELECTRICAL PARTS LIST CORRECTION

## CHANGE TO:

D604	152-0141-02	Silicon	1N4152
D614	152-0141-02	Silicon	1N4152
D622	152-0141-02	Silicon	1N4152
D625	152-0141-02	Silicon	1N4152
D630	152-0141-02	Silicon	1N4152
D632	152-0141-02	Silicon	1N4152
D635	152-0141-02	Silicon	1N4152
D641	152-0141-02	Silicon	1N4152
D642	152-0141-02	Silicon	1N4152
D643	152-0141-02	Silicon	1N4152
D644	152-0141-02	Silicon	1N4152
D645	152-0141-02	Silicon	1N4152
D646	152-0141-02	Silicon	1N4152
D651	152-0141-02	Silicon	1N4152
D652	152-0141-02	Silicon	1N4152
D653	152-0141-02	Silicon	1N4152
D654	152-0141-02	Silicon	1N4152

ELECTRICAL PARTS LIST CORRECTION

CHANGE TO:

D655	152-0141-02	Silicon	1N4152
D656	152-0141-02	Silicon	1N4152
D688	152-0141-02	Silicon	1N4152
D689	152-0141-02	Silicon	1N4152

TYPE 3A3

TENT SN 5790

ELECTRICAL PARTS LIST CORRECTION

CHANGE TO:

R251L	323-0754-01	66.2 k $\Omega$	1/2 W	MF	Prec	.5%
R251M	323-0755-01	196.4 k $\Omega$	1/2 W	MF	Prec	.5%
R451L	323-0754-01	66.2 k $\Omega$	1/2 W	MF	Prec	.5%
R451M	323-0755-01	196.4 k $\Omega$	1/2 W	MF	Prec	.5%