

100 GHz Through-Line Sampler System with Sampling Rates in Excess of 10 Gsamples/second

Agoston Agoston, Steve Pepper, Robert Norton,

John Ebner, and Kipp Schoen

Picosecond Pulse Labs (PSPL), Boulder, CO, 80301, USA

Abstract — A through-line electrical sampler with 100 GHz of bandwidth and sampling rates in excess of 10 Gsamples/s has been fabricated and characterized. The sampling aperture is estimated to be approximately 3 ps. The linear dynamic range is 2Vpp. The performance of this sampling component enables significant advancements in high-speed test and measurement equipment and mm-wave Ultra-wideband (UWB) receivers.

I. INTRODUCTION AND BACKGROUND

Sampling technology plays an important role in the measurement and characterization of high-speed signals. Consequently, many applications utilize sampling technology, including digital sampling oscilloscopes, real-time sampling oscilloscopes, and Ultra-wide-band (UWB) receivers.

Sampling devices have evolved over the years to incorporate numerous advancements in semiconductor materials, device fabrication, and RF packaging technology [1], [3]. Today, digital sampling oscilloscopes are available with sampling bandwidths up to 70 GHz and real time oscilloscopes are available with bandwidths up to 6 GHz (20 Gsamples/sec) [2]. These instruments are important tools in the development of high-speed communications links. In addition, recent development work with UWB signals has increased the need for high-speed sampling technologies in UWB receivers.

Some of the important parameters that characterize a sampling system include bandwidth, minimum aperture, maximum sampling rate, linearity, and sampling efficiency. The bandwidth and minimum aperture of a sampler are related in that the minimum aperture is the smallest window of time over which a signal may be measured. Therefore, the minimum aperture will determine the fastest signal that may be accurately measured.

Some of the challenges of realizing high-speed sampling systems include fabricating high-bandwidth sampling diodes, generating fast sampling or strobe signals, implementing precision time-bases, and fabricating high-bandwidth interconnects and packaging.

II. DESCRIPTION OF PSPL SAMPLING DEVICE

The sampler, and the system used to evaluate it, is described in this paper contain multiple components, including sampling diodes, a high-speed strobe generator, and a precision variable delay line. Customized GaAs Schottky diodes are used for the sampling diodes. Customized GaAs Schottky diodes are also used in proprietary Non-Linear-Transmission-Lines (NLTL) that provide fast signal transitions (generating the high-speed strobe) and voltage-controllable precision delay lines.

The use of NLTL technology in the strobe generation allows sampling rates far in excess of the SRD-based strobe generators used in commercial sampling scopes and network analyzers.

The sampling diodes and NLTL devices were produced using a proprietary in-house GaAs/thin film process. The sampling diodes are packaged together with the strobe generating NLTL's into a sampling head. The RF through-line on the sampling head is connectorized with 1 mm connectors. A photo of the 100 GHz sampling head is shown in Figure 1.



Figure 1. Packaged 100 GHz Sampling Head

II. EXPERIMENTAL SET-UP

Generally speaking, the technology needed to accurately test a 100 GHz sampler is not commercially

available. Therefore, the time domain evaluation of a 100 GHz sampler system involves a set of challenges. These challenges include:

1. Providing a stimulus with a comparable or faster rise time than the sampler.
2. Maintaining sub-picosecond jitter between the stimulus and the sampling strobe.
3. Realizing an ultra-fast coaxial interconnect between the stimulus and the sampler.

To meet these requirements we have developed a measurement system specifically for the characterization of the 100 GHz sampler. A block diagram of this system is shown in Figure 2.

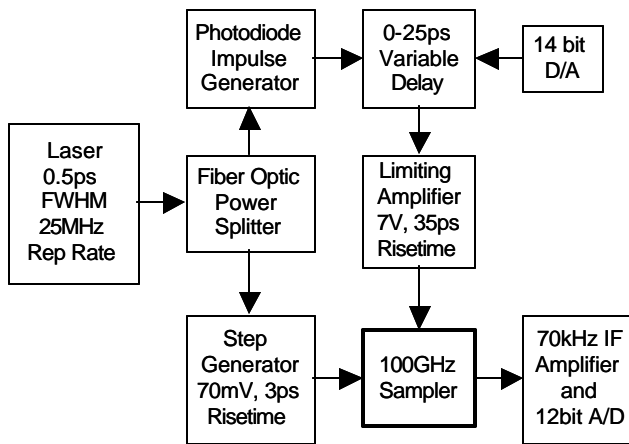

Figure 2. 100 GHz Sampler Test System

In this measurement system, a laser generates 0.5 ps FWHM pulses at a 25 MHz repetition rate. A fiber optic power splitter divides the laser beam into two equal amplitude optical pulses. One of the optical pulses drives a proprietary Optical-Electrical step generator in a 1-mm coaxial package connected to the RF input of the sampler.

The other optical pulse is connected to a high-speed photodiode that generates an electrical pulse to the LO drive chain. This pulse is delayed with an NLTL-based precision variable delay line controlled by a 14 bit, +/- 3 V range D/A converter. This creates a fast edge with voltage variable delay over 25 ps. This edge is amplified and applied to the strobe (Local Oscillator/LO) input.

The IF output of the sampler is connected to a unity gain buffer amplifier and digitized with a 12 bit, +/-3 V range A/D converter. Linearization of the timebase is performed in software and applied to the voltage driving the voltage-variable delay line.

III. RESULTS

A typical fall time measurement from this system is illustrated in Figure 3. The time difference between the 90% and 10% points is 4.3 ps (assumes a 10% overshoot in the measured signal). This fall-time measurement includes the effects of the stimulus, the sampler and the total system jitter.

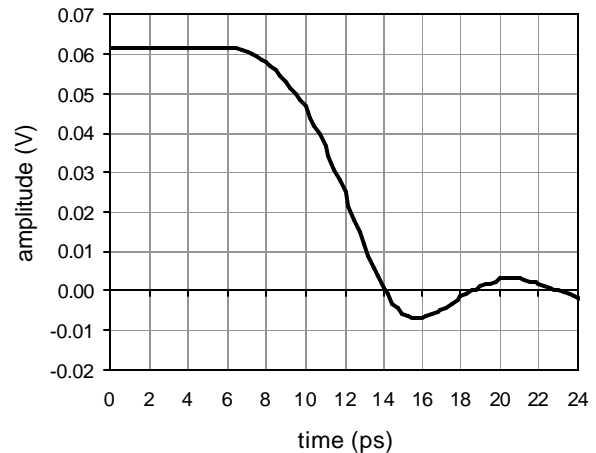

Figure 3. 100 GHz Sampler Measured Fall Time

Characterization of the system jitter in a 70 kHz IF bandwidth system, yielded RMS jitter below 100 fsec. Estimating an equal contribution to the fall time from the stimulus and sampler, and assuming that the contribution of the jitter is negligible, a fall time of 3 ps is estimated for the sampler. This corresponds to a -3 dB bandwidth of 113 GHz.

Characterization of the LO drive efficiency is also one of the difficult issues with high-speed sampler design. For reference a generic schematic of a two-diode sampler is shown in Figure 4. A technique has been developed that allows certain dynamic characteristics of the sampler to be obtained from DC I-V measurements of the IF ports while the sampler is actively strobed from the LO ports. These measurements yield the strobe amplitude at the sampler diodes, charge transfer efficiency, linearity, and dynamic range for a given diode bias voltage. It can also give information on the shape and symmetry of the strobe waveform.

The LO strobe amplitude was characterized using an Agilent 4145 Semiconductor Parameter Analyzer which was programmed to sweep the IF voltage on both IF terminals from 0V to +3V simultaneously while applying a voltage to the RF input which was stepped from -1V to 1V. During these sweeps the IF current is measured.

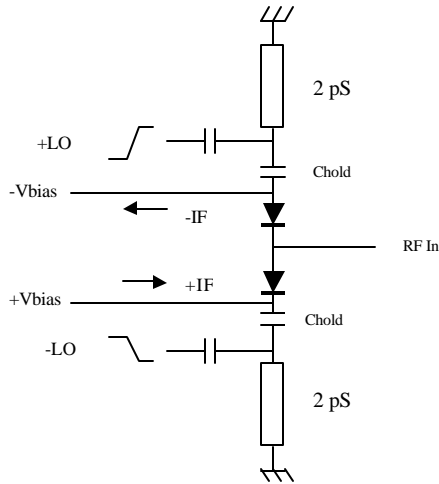

Figure 4. Schematic of a generic two diode sampler.

The strobe amplitude at the sampler diodes is measured as the point at which the IF current drops to zero (with zero volts applied to the RF input), indicating that there is insufficient strobe amplitude to forward bias the sampler diodes. The charge sampling efficiency is obtained from the

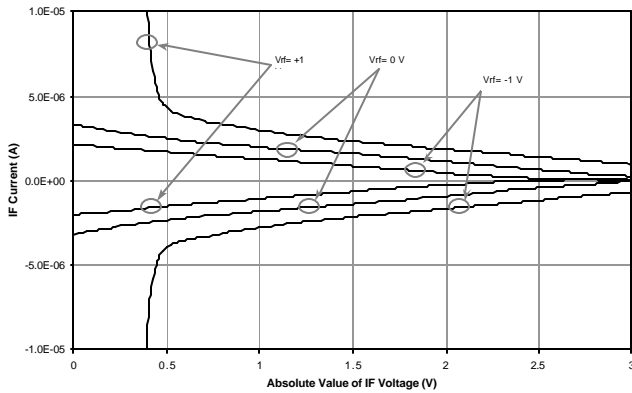

Figure 5. IF current versus IF and RF voltages at 25 MSps repetition rate with 0.4 mA of forward bias on the LO NLTL.

difference in average IF current when the RF port bias is switched from zero to full scale. The charge per sample is obtained by dividing the average current by the sample rate. The linearity of the sampling efficiency is shown by its independence of the IF bias voltage. The data shows that the sampling aperture is independent of the IF bias, which implies that the sampling aperture has a flat top with steep transitions.

A summary of the measured performance of the 100 GHz sampler system is given in Table 1.

Table 1. 100 GHz Sampler Measured Performance

Parameter	Value
Aperture	3 ps
System Jitter	100 fsec RMS
RF Bandwidth	> 100 GHz
RF Input Dynamic Range	2 Vpp
RF Impedance	50 Ω
RF Path	through-line
Sample Rate	> 10 Gsamples/sec
Sampling Efficiency	60%
RF Connectors	1 mm

V. SUMMARY AND CONCLUSIONS

The sampling system described in this paper demonstrates a bandwidth in excess of 100 GHz. Although the sample rate in the evaluation system was 25 MHz, the LO drive and NLTL strobe generation are capable of sample rates in excess of 10 GHz.

It has been demonstrated that this sampling system design effectively addresses the technical issues of sampling diode bandwidth, the generation of fast strobe signals, precision time delay, and high-bandwidth interconnection and packaging.

REFERENCES

- [1] "50 Years of RF and Microwave Sampling", M. Kahrs, pending publication.
- [2] Information from Agilent product website.
- [3] US Patent Applications 20020167373 and 20020145484.