

WARNING

THE FOLLOWING SERVICING INSTRUCTIONS ARE FOR USE BY QUALIFIED PERSONNEL ONLY. TO AVOID PERSONAL INJURY, DO NOT PERFORM ANY SERVICING OTHER THAN THAT CONTAINED IN OPERATING INSTRUCTIONS UNLESS YOU ARE QUALIFIED TO DO SO.

PLEASE CHECK FOR CHANGE INFORMATION AT THE REAR OF THIS MANUAL.

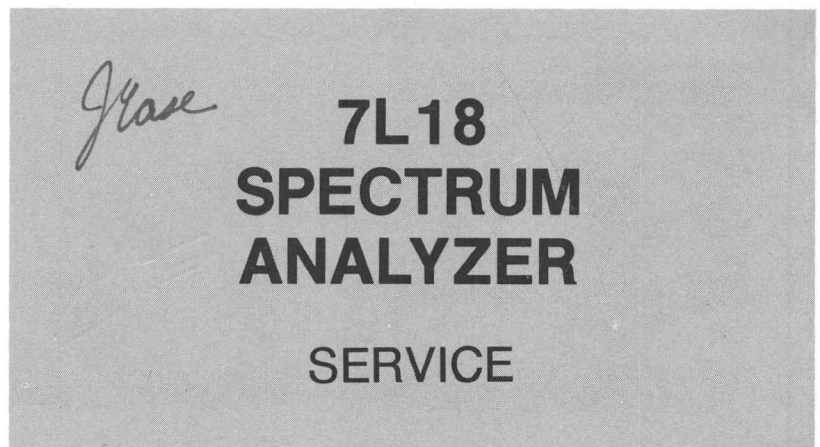

INSTRUCTION MANUAL

Copyright © 1977, 1978, 1979, Tektronix, Inc. All rights reserved. Contents of this publication may not be reproduced in any form without the written permission of Tektronix, Inc.

Products of Tektronix, Inc. and its subsidiaries are covered by U.S. and foreign patents and/or pending patents.

TEKTRONIX, TEK, SCOPE-MOBILE, and  are registered trademarks of Tektronix, Inc. TELEQUIPMENT is a registered trademark of Tektronix U.K. Limited.

Printed in U.S.A. Specification and price change privileges are reserved.

TABLE OF CONTENTS

	Page
SECTION 1	INTRODUCTION 1-1
SECTION 2	CIRCUIT DESCRIPTION 2-1
	INTRODUCTION 2-1
	PRESELECTOR AND FIRST LOCAL OSCILLATOR 2 2-1
	FIRST CONVERTER 2 2-2
	INTERMEDIATE FREQUENCY AMPLIFIERS 3 2-2
	THREE-CAVITY FILTER 3 2-2
	500 MHz LOCAL OSCILLATOR, CALIBRATOR, and SECOND CONVERTER 4 2-2
	VARIABLE RESOLUTION FILTERS 5, 6 2-3
	NOISE FILTERS 8 2-3
	LOG AMPLIFIER 8 2-3
	DETECTOR 9 2-3
	VIDEO AMPLIFIER 9 2-3
	SWEEP GENERATOR 11 2-4
	SPAN ATTENUATOR 12 2-6
	FIRST LOCAL OSCILLATOR AND PRESELECTOR DRIVER 13, 14 2-9
	REFERENCE VOLTAGE BOARD 14 2-9
	PHASE LOCK SYSTEM 15, 16, 17, 18 2-9
	DISPLAY MODE AND DEGAUSS SWITCHES 19 2-13
	MICROCOMPUTER 21 2-14
	CENTER FREQUENCY DIGITAL VOLTMETER 22 2-14
	CENTER FREQUENCY AND CRT READOUT BOARDS 23, 24 2-16
	DIGITAL STORAGE 25, 26, 27 2-21
SECTION 3	SERVICE INFORMATION 3-1
	GENERAL 3-1
	TEST FIXTURES 3-3
	SETTING THE CONSTANT K 3-3
	ELAPSED TIME METER 3-3
	LOSS OF SIGNALS ON DISPLAY 3-4
	REPLACEMENT OF YIG OSCILLATOR 3-5
SECTION 4	CALIBRATION PROCEDURE 4-1
SECTION 6	ELECTRICAL PARTS LIST
SECTION 7	SCHEMATIC DIAGRAMS
SECTION 8	MECHANICAL PARTS LIST
CHANGE INFORMATION	



INTRODUCTION

This is an interim service manual. It is our intention to provide as much and as complete information as possible to aid in servicing. We welcome all suggestions, corrections, criticisms, and contributions you care to make.

The 7L18 Spectrum Analyzer is a three-unit-wide plug-in unit for Tektronix 7000-Series oscilloscope mainframes. The analyzer covers the spectrum range from 1.5 GHz to 18 GHz in five bands with direct input, and 12.5 GHz to 60.5 GHz in six bands with external waveguide mixers. The instrument features digital storage, internal preselector, a dynamic range of 80 dB, less than 10 Hz of incidental oscillator frequency modulation, and a resolution bandwidth range of 30 Hz to 3 MHz. Further description and complete specifications appear in the Operator's Manual.

Although the 7L18 is a highly complex instrument with high component density, its modular design aids its serviceability. IC and transistor sockets are used where possible, and most circuit card interconnections are made via plugs rather than soldered connections. Adjustment and test point locations are conveniently located where possible. Modular design should reduce instrument downtime by allowing defective modules to be exchanged. Much of the troubleshooting and circuit description information will be module-oriented.



CIRCUIT DESCRIPTION

INTRODUCTION

The circuit descriptions in the following sections are intended to give an overview of the 7L18's functions. This should aid in troubleshooting the various systems in the instrument. It may also aid in understanding how to utilize the full capabilities of the 7L18 for particular applications.

A simplified block diagram of the 7L18 is located on the first tabbed pull-out sheet. The blocks on this diagram represent two types of circuits: control circuits and signal circuits. The control circuits include the sweep generator, span attenuator, oscillators and drivers, and switching circuits necessary to make the instrument function. The signal circuits include the attenuator, preselector, mixers, amplifiers, filters, and other stages that process the signals to form the crt display. Not included in this diagram are the switching functions and control logic, and front panel controls. All blocks are discussed in greater detail in the following sections. The numbers in the diamonds refer to the corresponding schematic diagrams. Note that these numbers on block diagram 1 provide an index of most of the schematics (not all schematics are referenced on the block diagram).

PRESELECTOR AND FIRST LOCAL OSCILLATOR

The first local oscillator of the 7L18 operates in the 2 to 4 GHz region. With the 510 MHz intermediate frequency, the input frequencies that may be tuned using a fundamental conversion are 1.5 to 3.5 GHz or 2.5 to 4.5 GHz (bands 1 and 2). With higher input frequencies, conversions are with harmonics of the local oscillator frequency (for the actual harmonics used, refer to Table 1-1 in the Operator's Manual). The oscillator's fundamental or harmonic is 510 MHz away from the displayed signal, either above or below, depending upon the band being used.

The preselector and first local oscillator utilize YIG (Yttrium-Iron-Garnet) spheres. This material resonates at a frequency which varies in proportion to the magnetic field caused by a current through an electromagnet. The preselector is a tunable bandpass filter with a bandwidth of about 50 MHz. It is tunable through the range of 1.5 to 18 GHz, and tracks the portion of the spectrum being displayed.

Since the intermediate frequency is relatively low compared to the operating frequencies and available spans, and since the mixer produces many harmonics, the instrument is potentially capable of many conversions other than the one intended. The preselector selects which conversion is allowed. This results in a spurious-free, unambiguous display.

Internally, the preselector consists of three cascaded sections. Each section contains a YIG sphere and input and output loops oriented so that their axes are perpendicular to each other and to the applied magnetic field. The resonant frequency of the filter is proportional to the applied magnetic field.

The preselector, as well as the YIG oscillator, is not repairable in the field, and should be returned to the factory in case of failure.

FIRST CONVERTER

In the first converter, incoming signals from the preselector are mixed with the first local oscillator signal to produce a 510 MHz intermediate frequency (*if*). The mixing action is accomplished by the inherent nonlinearity of the diode in assembly A45.

The first converter assembly also serves to route signals to the front panel EXT MIXER connector. This connector supplies the local oscillator signal and dc bias to the mixer, and also receives back the intermediate frequency from the mixer.

INTERMEDIATE FREQUENCY AMPLIFIERS

The heterodyne action of the mixer produces an intermediate frequency signal that contains a frequency component for every frequency component in the input, but is translated in frequency. These offset signals sweep past the 510 MHz input frequency of the first *if* amplifier; a deflection is produced on the analyzer screen each time a frequency component falls within the *if* passband. A logic signal controls whether the waveguide bands input or the coaxial bands input to the *if* amplifier is enabled.

The *if* amplifier uses three or four stages of gain with two stages of PIN diode attenuation. The attenuators change gain as necessary to accommodate changes in attenuation of the first converter with different bands.

THREE-CAVITY FILTER

The output of the 510 MHz *if* amplifier is applied to a three-pole bandpass filter with a bandwidth of 3 MHz. The filter network consists of three helical resonators, and is the main selective element in the analyzer when operated in the 3 MHz resolution bandwidth position.

500 MHz LOCAL OSCILLATOR, CALIBRATOR, AND SECOND CONVERTER

The second local oscillator uses a 125 MHz fifth overtone crystal, and has a tuned output. The oscillator signal then passes through two frequency doublers, a leveling attenuator, a power amplifier, and a band pass filter, then is coupled to the second converter and the calibrator circuit. The calibrator includes a harmonic generator which generates a series of frequency markers with 500 MHz spacing. The 1500 MHz marker is accurately adjusted to -30 dBm by a control in the leveling loop.

The second converter mixes the 510 MHz *if* output from the three-cavity filter with the 500 MHz second local oscillator to produce the 10 MHz second intermediate frequency.

VARIABLE RESOLUTION FILTERS  

The variable resolution circuitry includes the six resolution bandwidth filters and their switching circuits. The switching is done with diodes which are driven from a CMOS analog switch. The six bandwidths available are from 3 MHz to 30 Hz in decade steps. A combination of L-C filters and crystal filters are used to obtain the desired bandwidths. The filtering for the four wider bandwidths are contained in the VR module, while the 30 and 300 Hz filters are placed elsewhere in the instrument with double shielded coaxial cables used for interconnection. The 30 Hz filter also includes a built-in oven to ensure stability of its high Q crystals. The operating frequency of this system is 10 MHz.

The variable resolution section also provides several gain controlling functions. The front-panel mounted AMPLITUDE CAL potentiometer is used for amplitude calibration of the instrument; the amplifier that is controlled is in the input of the variable resolution section. Similarly, the REF VAR control (which is uncalibrated) interfaces with a PIN diode in the later part of the variable resolution system. Additionally, fixed gain steps may be added in this amplifier in amounts of 10, 20, or 30 dB. These gain steps, in conjunction with others in the log amplifier (described later) allow the user to place the instrument noise floor on screen for any resolution bandwidth condition.

NOISE FILTERS 

The noise filters reduce the bandwidth of the amplifiers feeding the log amplifier. This function is required in order to minimize the baseline noise that might result from noise generation in the latter stages of the variable resolution amplifiers.

LOG AMPLIFIER 

The log amplifier compresses the input signal before sending it to the detector. This compression makes it possible for the input signal to vary over a 90 dB range while feeding the detector which is linear over a 35 dB range. By carefully controlling the characteristics of the compression curve, each dB change in the input results in an equal increment of output. For instance, in the 10 dB/DIV mode, each time the input varies 10 dB in amplitude, the output varies by one division.

DETECTOR 

The detector circuit, included on the Video Amplifier diagram, changes the 10 MHz signal to a dc level that varies in accordance with the log of the signal amplitude.

VIDEO AMPLIFIER 

This diagram shows the detector and video amplifier circuits. The detector circuit utilizes an operational amplifier to linearize the detection process. The detected video passes through a ripple filter to the first video amplifier where it is offset (this corresponds to a gain change before the log amplifier) and the gain is set for the display in use (10 dB/DIV or 2 dB/DIV). If LIN mode is selected, a four-segment shaper is used to "un-log" the video. The pulse stretcher and deflection amplifiers are also on this circuit board.

SWEEP GENERATOR

The sweep generator produces a sawtooth waveform that is used to sweep the crt horizontal axis, the YIG oscillator, and the YIG preselector. The sweep generator circuitry includes the triggering, selection of sweep speeds, and horizontal axis mainframe drivers. Refer to the table on Horizontal Sweep Diagram 11 for sweep speed selection logic.

The sweep generator uses two ICs. U1480 is the sweep control, and U1560 is the sweep generator. U1480 and its associated circuitry control the various events of the sweep cycle. Immediately after every sweep there is a holdoff period during which another sweep cannot occur. After this period, if the sweep is not in single sweep mode, the sweep runs after an interval determined by the bright baseline timing components (R1488 and C1489). If a trigger occurs (and the sweep is in a triggered mode) after the end of holdoff and before the end of the bright baseline interval, the sweep starts immediately. To initiate the sweep, $\overline{\text{GATE}}$ from U1480 goes low. This signal is inverted by Q1540 and applied to U1560. The high level at U1560 turns off an internal reset transistor, allowing U1560 output to ramp positive at a rate determined by a capacitor (C1555, C1557, or C1559, depending upon sweep speed) and the input current. When the ramp reaches the threshold voltage (set at 8.5 V) of a comparator in U1560, the comparator sends a signal back to U1480 to raise $\overline{\text{GATE}}$. This sets up the next holdoff period and turns on an internal reset transistor which shorts between the output and the summing node of the integrator, discharging the sweep capacitor.

If the sweep is in the single sweep mode, only one sweep will occur each time the SGL SWP button is pushed. There is no bright baseline in triggered modes in single sweep; unless FREE RUN is selected, the sweep will wait indefinitely for a trigger. This allows easy external triggering for photography. The READY indicator is on from the time the switch is pressed until the sweep ends. The holdoff time is determined by components external to U1480, and is changed with the sweep speed (not at every step, but whenever the sweep capacitor is changed, and at certain other places).

The selection of modes is done with three lines of U1480. Pin 13, when low, enables bright baselining. Pin 6, when low, selects single sweep mode. Pin 7, when taken high briefly, resets the single sweep, allowing one sweep. Pushing SGL SWP (when in single sweep mode) during a sweep will reset the sweep and start another, subject to trigger mode. The interfacing to the front panel triggering switches is done with discrete diode and transistor logic. Only one button is required for selection of single sweep mode and the initiation of each sweep. Pressing SGL SWP does not cancel the trigger source (LINE, INT/EXT, or FREE RUN), allowing either triggered or free-running single sweep operation. Pressing any other trigger control cancels SGL SWP.

The front panel switches control trigger source selection through three units of a quad comparator (U1410). The comparators—one each for INT, EXT, and LINE—have open collector outputs which are wire-OR'ed. The INT and EXT comparators are enabled together. Each comparator is disabled when the + input is taken high, and is enabled when the + input is brought to ground, allowing a signal on the - input to switch the comparator. Because of the sensitivity of the INT and EXT comparators, both inputs are referenced to the control line so that the TTL low of about 0.3 V will not falsely trigger the comparators. A clamp on the - input ensures that the + input goes higher when the comparator is disabled. The common output is sent to the trigger input of U1480.

Triggering takes place at zero volts, positive slope. Sensitivities are 0.5 division peak-to-peak for INT and 0.5 V peak-to-peak for EXT. LINE is dc-coupled, while INT and EXT are ac-coupled. An amplifier (U1390) in front of the INT comparator provides the required sensitivity.

The sweep lockout signal from the mainframe is interfaced through U1401 to pin 10 of U1480. When the sweep lockout is high, it ends any sweep in progress and prevents another sweep from occurring, irrespective of the settings of the trigger controls. The forced single sweep line places the sweep in single sweep and free run modes.

The sweep time per division code is obtained from the microcomputer through the 8 bit of port 0, and stored in an eight bit shift register (U1530). Three bits are used to select a timing resistor, two to select a timing capacitor, one to select the voltage which drives the timing resistor, and two to change the holdoff time.

The sweep speed has an eight decade range, from $1\ \mu\text{s}$ to 20 s/division. The fastest two decades—to $20\ \mu\text{s}/\text{div}$ —are covered by switching resistors. The capacitor is then switched, and the resistor sequence is switched again for the next two decades. For the next decade, the voltage is lowered and the last three resistors are switched with the same capacitor. The same sequence of switched capacitor, switched resistors, then switched voltage is repeated for the last three decades. The resistors are switched by a single-channel analog multiplexer (U1540) and the capacitors by half of a dual-channel unit (U1545). The other half of U1545 switches capacitors for the holdoff timing. Other holdoff capacitors are switched by transistors to change holdoff at points where the sweep capacitor is not changed.

In the manual and single sweep modes, the sweep capacitor is replaced by a resistor, making U1560 into an operational amplifier. U1540 selects either the manual span voltage or external voltage as an input source. The external input connector is the same as that used for external trigger. Level is 0 to $10\ \pm 1$ volts for a full-screen sweep. U1545 grounds the base of the transistor which inverts $\overline{\text{GATE}}$. This ensures that the gate to U1560 is always high regardless of the state of U1480, keeping the reset transistor off and the crt unblanked.

A line from the front panel OPTION connector switches input and feedback resistors onto U1560 to place the sweep voltage in the center of its range. This line also inhibits the timing current.

The voltage reference for the sweep is derived from the $-50\ \text{V}$ supply. U1610 develops a $+9.0\ \text{V}$ output.

U1595 is a selectable gain amplifier (selector switch is Q1610) which has an output of either $-0.9\ \text{V}$ or $-9.0\ \text{V}$. R1597 is part of the timing resistance. Q1595 switches in R1594 to form a voltage divider to lower the voltage, thus slowing the sweep to generate the MAX SPAN marker.

The $\overline{\text{GATE}}$ signal from U1480 is buffered and sent to the digital storage board, where it is used to control mainframe unblanking in the non-storage mode. The $\overline{\text{GATE}}$ signal is also ANDed with the $\overline{\text{READY}}$ signal (pin 9) which is low when the sweep is ready for triggering. The ANDed signal is buffered and sent as the holdoff signal to the mainframe. The outputs of U1480 are combined with information from the SGL SWP switch to derive the drive signal for the READY indicator.

The output of U1560 goes directly to the span attenuator board for driving the oscillators. It also goes to an amplifier which drives the A and B Sweep inputs of the mainframe. After amplification on the span attenuator board, the sweep goes through the SWP CAL control to the digital storage board. Either this sweep or the digital storage readout sweep is sent back to the sweep horizontal board. The horizontal amplifier sums this signal with that from the HORIZ POSITION control, and drives the mainframe at 50 mV/division on each side.

SPAN ATTENUATOR

The span attenuator controls the amplitude of the sweep signal that is coupled to the first LO driver or the phase lock circuitry, thus controlling the YIG oscillator frequency deviation to set the span, or frequency/division. Refer to Figures 2-1 and 2-2 for attenuator settings for phase locked and non-phase locked operation, respectively, and to Figure 2-3 for a block diagram. When phase locked, the ramp must also be scaled as a function of the phase lock harmonic, which varies with center frequency tuning. The scaling is done automatically by programmable fixed and variable attenuators. The fixed attenuator is a simple divider which can reduce the ramp by powers of ten. The variable attenuator handles the high-resolution part of the scaling.

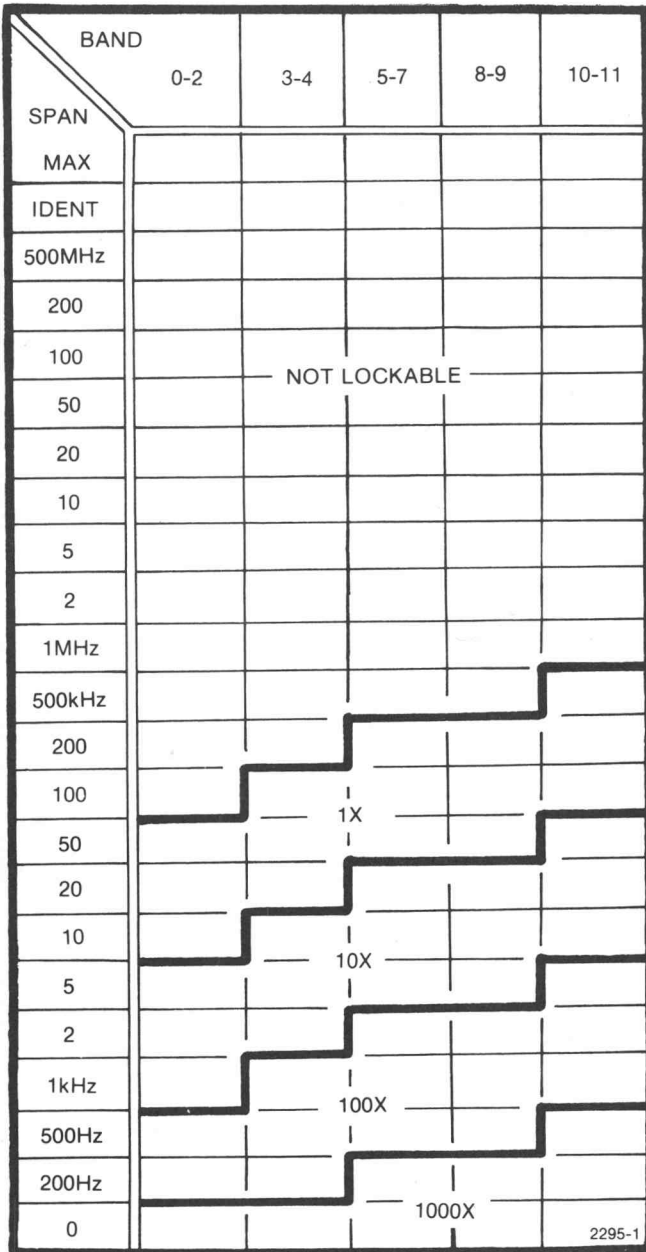

Figure 2-1. Fixed span attenuator selection vs SPAN and BAND settings for phase locked operation.

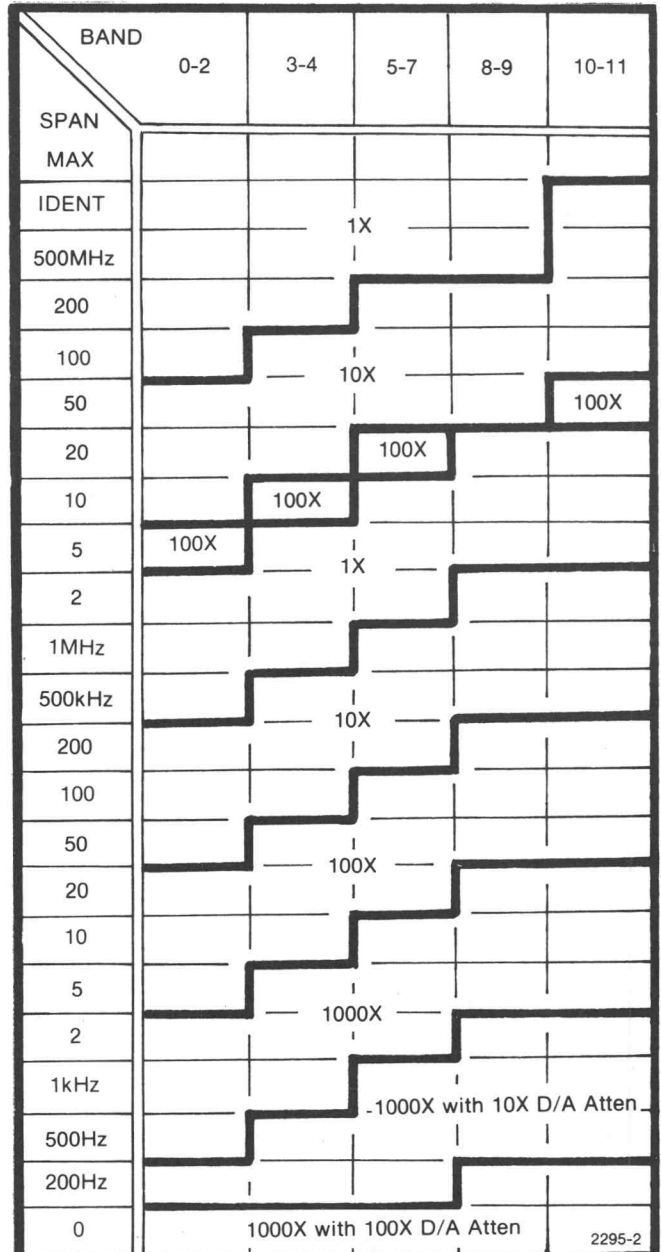

Figure 2-2. Fixed span attenuator selection vs SPAN and BAND settings for non-phase locked operation.

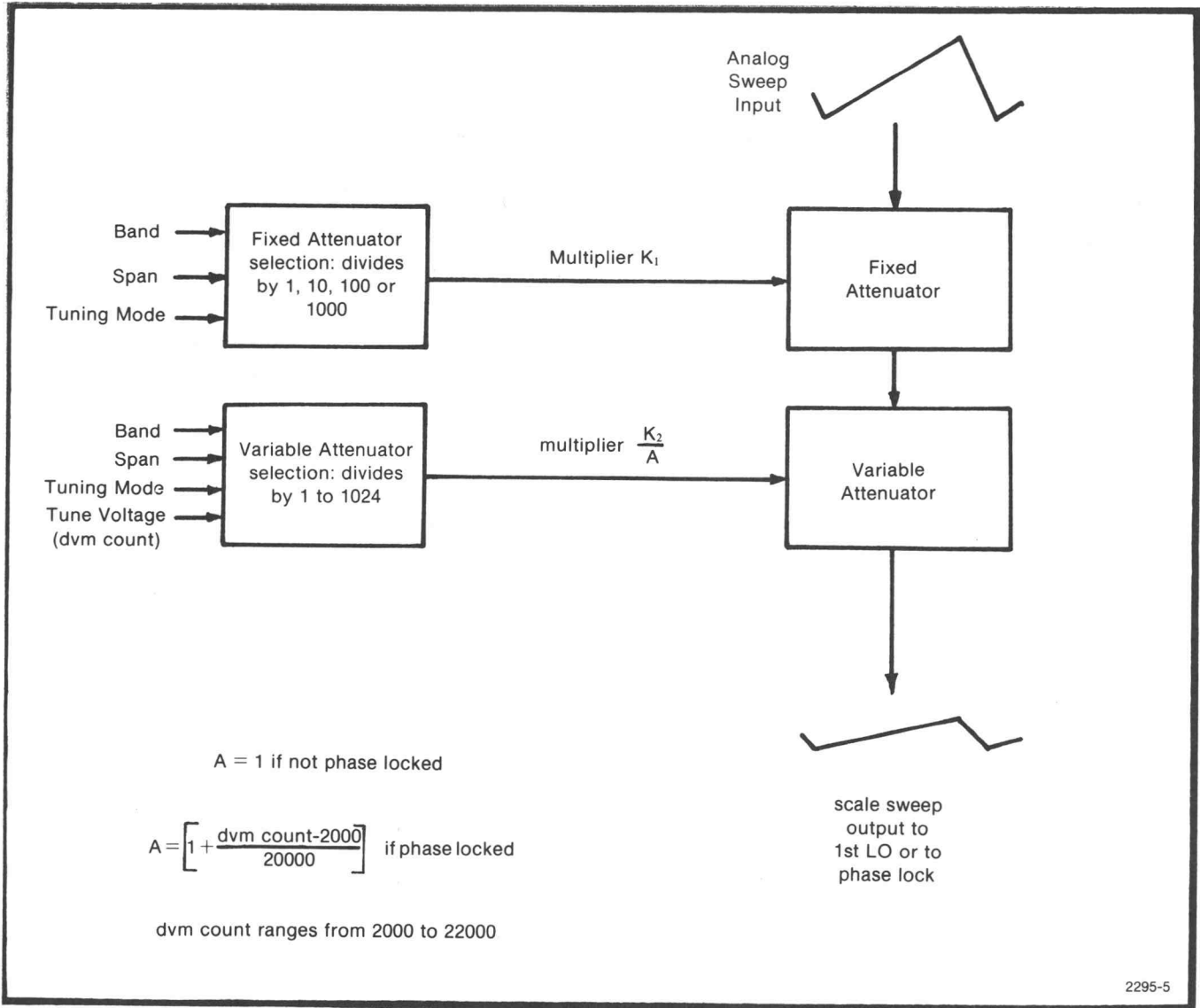

Figure 2-3. Span Attenuator block diagram.

FIRST LO AND PRESELECTOR DRIVER  

The First Local Oscillator and Preselector Driver receives the attenuated sweep voltage, combines it with the TUNING voltage, and converts it to a current that drives the first local oscillator main tuning coil. The current also drives the preselector tuning coil, but is first multiplied and offset according to the band in use, in order to provide proper tracking.

On narrower spans depending on the band in use, only the TUNING voltage signal is applied to the main tuning coil, and the oscillator is swept by either applying the attenuated sweep voltage directly to the fm coil, or indirectly through the phase lock circuitry.

A different multiplier and offset is used for each band. Adjustments can be made on offset and multiplier for each band; one control moves the adjustment range up and down, while the other rotates it about the center point.

In MAX SPAN the local oscillator sweeps over its full range. A marker is generated by comparing the sweep and tune volts in the driver, and sending a signal back to the sweep to slow it down briefly, so that on fast sweeps (when the sweep is faster than the flicker rate) it appears as a bright spot, and on slow sweeps it appears as a pause.

The YIG oscillator board is soldered to the YIG oscillator terminals, interfacing the oscillator to the cables coming from the instrument. In addition, it holds the noise filter capacitors for the main oscillator coil, the relay for switching the capacitors, and a clamp diode for the oscillator collector supply.

REFERENCE VOLTAGE BOARD 

This circuit generates the reference voltages used for the CENTER FREQUENCY TUNING controls, and for the first local oscillator driver offsets.

The voltage reference for the supply is filtered and applied to an amplifier with a variable gain that allows precise voltage settings. The output of this amplifier is the -10 V reference. The -10 V is inverted by another amplifier to produce the $+10$ V reference. Both amplifiers have output buffers. Resistors with extremely low temperature coefficients are used in critical places to ensure temperature stability.

PHASE LOCK SYSTEM    

Because it must tune and sweep, the first local oscillator does not have the stability of a fixed oscillator. Since the drift of the oscillator is indistinguishable from drift of a signal, the 7L18 includes a system which, at narrower spans, phase locks the first local oscillator to a stable sweeping source. This gives the locked oscillator approximately the same fractional stability as a crystal oscillator. The sweep is then applied to the phase locked loop, rather than to the oscillator directly.

The phase lock circuitry is discussed in two parts. The first part, called the inner loop, covers the generation of the strobe, or reference frequency, to which the YIG oscillator is locked. The second part, called the outer loop, discusses the circuitry necessary to lock the YIG oscillator to the strobe.

Inner Loop

The inner loop includes three oscillators (refer to Figure 2-4): a crystal reference oscillator, a movable reference oscillator (referred to as the offset oscillator), and the controlled oscillator, which is phase locked to the sum of the reference and offset oscillators. Controlled oscillator frequency = Reference oscillator frequency + offset oscillator frequency/64. The controlled oscillator frequency (16 MHz) is divided by four and used as the source for the strobe driver. This strobe is the reference to which the first local oscillator is phase locked.

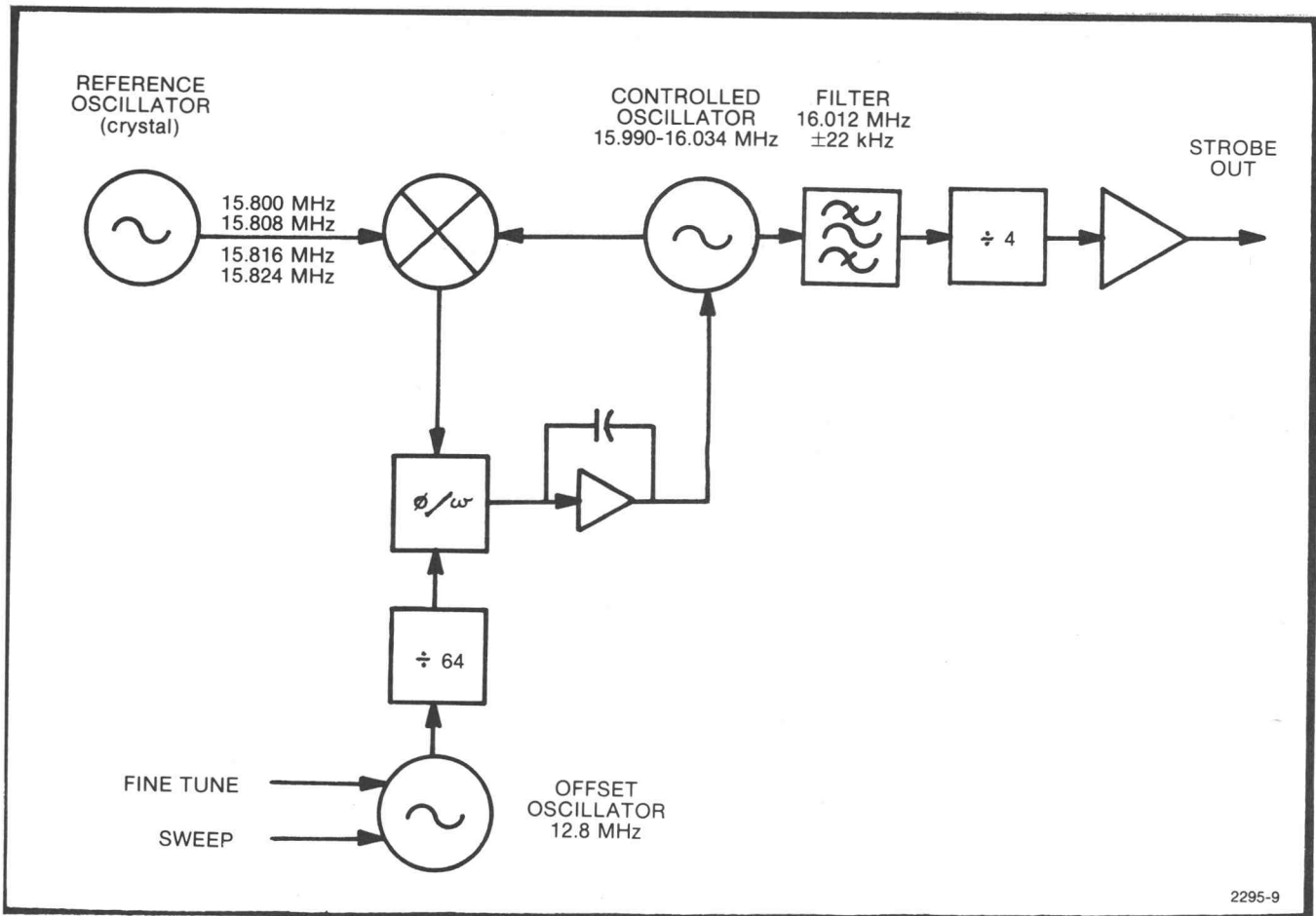

Figure 2-4. The inner loop serves as the frequency reference for the outer loop of the phase lock system.

The **reference oscillator** is comprised of four crystal resonators at 15.800, 15.808, 15.816, and 15.824 MHz. A 1 Hz change in this oscillator moves the harmonics of the strobe at 2 GHz at about 125 Hz and about 250 Hz at 4 GHz when the offset oscillator is centered at 12.8 MHz. Therefore, the 8 kHz spacing between crystal frequencies moves the strobe lines in increments of 1 MHz at 2 GHz. Both the positive and negative supplies of the reference oscillator are Zener referenced to reduce the affects of power supply variations and coherent side bands from other circuits in the 7L18.

The **offset oscillator** sweeps the controlled oscillator to interpolate between lock points, and to provide fine tuning. The offset oscillator frequency is divided by 64, then added to the reference oscillator frequency, and again divided by four for a total division ratio of 256. When locking the YIG oscillator at 2 GHz, the strobe signal is multiplied up about 500 times, depending on the reference oscillator frequency. This means that a 1 Hz change in the offset oscillator will move the YIG oscillator frequency about 2 Hz ($500/256$) when the strobe line is at 2 GHz. Note that the multiplication ratio depends on the YIG oscillator frequency, thus a 1 Hz change in the offset oscillator will cause a 4 Hz change in the strobe line at 4 GHz.

The recenter range of the offset oscillator is only 1.2 MHz on-screen at 2 GHz and the strobe line must also move 500 kHz (± 250 kHz) to give a fine tune range of one screen diameter in the widest phase lock position. The strobe must also provide a sweep of 500 kHz on screen. This means that the strobe must move another 1 MHz. The total range of the YIG oscillator, therefore, must be 2.2 MHz at 2 GHz. Hence, the offset oscillator must move 1.1 MHz because of the 2:1 multiplication ratio discussed previously.

The **mixer** combines the reference oscillator, at about 15.8 MHz, with the controlled oscillator, at about 16 MHz. The difference frequency of 200 kHz is applied to the phase/frequency detector through a low pass filter which prevents the 15.8 MHz and 16 MHz signals from getting into the phase detector.

The **phase/frequency detector** and **compensation amplifier** locks the output from the mixer to the offset oscillator. This lock loop has a bandwidth of about 10 kHz because it must be swept.

Before going to the strobe driver, the output signal from the controlled oscillator is filtered by a 6-pole monolithic filter to remove the residual 200 kHz sideband (200 kHz being the update rate of the phase/frequency detector).

Since the strobe rate is about 4 MHz, there is a strobe frequency line approximately every 4 MHz to some frequency greater than 4 GHz, the upper end being determined by the bandwidth of the phase gate sampler. At 2 GHz, the strobe frequency increments in 1 MHz steps when a crystal in the reference oscillator is replaced by an adjacent crystal. The range allowed in the offset oscillator moves the strobe 1.2 MHz at 2 GHz to give a 20% overlap. At 4 GHz, the minimum spacing due to incrementing a crystal is 2 MHz. However, the strobe harmonic at 4 GHz now moves twice as far, or 2.4 MHz, when the offset oscillator is varied as before, thus no additional range is required from the offset oscillator.

Outer Loop

The outer loop locks the YIG oscillator to the reference (refer to Figure 2-5), and performs a host of other functions as follows:

- Connects the compensation amplifier to the YIG oscillator when in phase lock positions.
- Provides search when not locked.
- Provides a time delay from when the strobe is turned on to when the error amplifier is connected.
- Varies lock-in range as a function of tune voltage.
- Commutates between crystals in the reference oscillator.
- Locks the YIG oscillator to the strobes.
- Senses when lock is achieved.
- Moves the strobe reference to recenter the YIG oscillator.
- Connects the sweep and offset oscillator filter after lock occurs.
- Limits hold-in range.

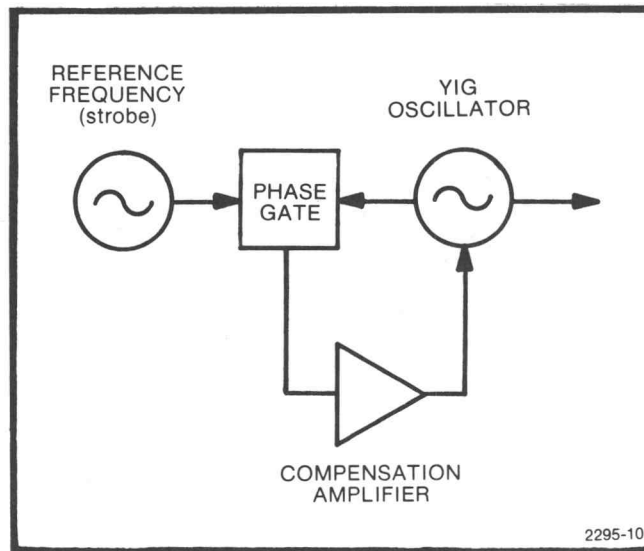

Figure 2-5. Outer loop of the phase lock system.

The **compensation amplifier** and **search oscillator** form a conditionally stable amplifier that requires the phase lock loop to have acquired, to become stable. When the loop is not locked, the compensation amplifier oscillates at about a 3 Hz rate. As the amplifier oscillates, the YIG oscillator searches an amount somewhat greater than 2.4 MHz.

The search voltage moves the oscillator more than the distance between strobe lines to ensure that neither temperature effects nor dc balance errors from the phase gate will change the lock-in range. As we discussed earlier, the lock-in range when the YIG oscillator is at 2 GHz must be greater than 1 MHz, the spacing between crystals, and less than 1.2 MHz, the maximum recenter range of the offset oscillator. At 4 GHz these numbers are 2 MHz and 2.4 MHz respectively.

The output voltage of the search oscillator is monitored, and when this voltage exceeds an absolute value determined by the tune voltage, a Lock Inhibit command is given. In this manner, the allowable lock-in range is varied a factor of two as the oscillator is moved from 2 to 4 GHz.

If the allowable lock-in range is exceeded, the oscillator was not able to acquire lock with the crystal in use, and a new crystal is selected. The inner loop has time to settle before the search oscillator comes back into lock-in range and the new crystal is tried.

Eventually the YIG oscillator locks to the strobe reference and the search oscillator stops oscillating. After a fixed period of time has elapsed to ensure that the lock is real, lock is sensed, and the crystals are no longer allowed to change.

Next, the YIG oscillator is recentered so that an on-screen signal will be in the same place it was before lock was initiated. This is done by applying a correction voltage to the offset oscillator from an 8-bit digital-to-analog converter, until the error voltage from the phase gate is zero. This converter is very stable to ensure low drift of the offset oscillator. If, for some reason, the converter doesn't have enough range to recenter the oscillator, the lock sequence is started again, with provisions to ensure that the next crystal in the sequence is tried first.

After the YIG oscillator is locked to the strobe reference and returned to the frequency it was before lock was initiated, the sweep voltage is connected to the offset oscillator to sweep the reference. The bandwidth of the outer loop must be wide enough, about 10 kHz, to ensure that the loop remains locked during sweep and retrace. The hold-in range of the loop is about 4 MHz to allow for the sweep, fine tune range, and drift of the oscillator.

DISPLAY MODE AND DEGAUSS SWITCHES

The display mode switches (10 dB/DIV, 2 dB/DIV, LIN) control the decoding of the display mode for the crt readout, and send a display mode control signal to the log amplifier and vertical board. The 10 dB/DIV switch also indicates to the microcomputer when this mode is selected. (The microcomputer uses this information to limit the maximum *if* gain allowed in the 10 dB/DIV position.)

The DEGAUSS switch shorts the main oscillator and preselector coils when pushed. This sets the current in the coils to zero and establishes a known magnetic history in the cores.

MICROCOMPUTER

The microcomputer takes care of a variety of housekeeping functions within the 7L18: it reads the settings of most of the front panel controls and appropriately services the sweep generator, span attenuator, first local oscillator and preselector drivers, *if* amplifier gains and bandwidths, center frequency dvm, and crt and front panel readouts. From the user's point of view the microcomputer is most apparent in the 7L18's AUTO modes: when AUTO BANDWIDTH and AUTO TIME/DIV are selected, these functions are based upon the BAND, SPAN/DIV, and PHASE LOCK control settings (refer to Operator's Manual, Sections 3.3.2.1 and 3.5.3).

The microcomputer consists of a microprocessor plus the assembly of the I/O (Input/Output) buffers, ROM, etc. The microprocessor controls everything except the trigger and the display, which are hard-wired, and the TUNING controls; all other controls are fed to the microcomputer through the data bus. The microcomputer uses about 3000 instructions, which are contained on the ROM ICs. Each controlled condition is set up and latched at the particular interface address, so that the microcomputer does not have to continually service a port; it only does so when a condition changes (front panel setting, etc).

The First Local Oscillator and Preselector Driver Interface controls the band the filter is on, whether a marker is generated or not (markers are generated only in MAX SPAN), blanking (blanking is different on band 5 than all other bands), sweep speed, attenuation setting of the span attenuator, and readout. It also reads whether digital storage is on or not, and reads the front panel controls and dvm.

The Vertical Microcomputer Interface selects the coaxial or waveguide input to the 510 MHz *if*, controls the gain and bandwidth of the variable resolution filters, and reads the front panel controls.

In operation, the program checks the front panel; assuming nothing has changed, it reads the dvm to see if it is the same as last time. If so, it stays in this loop. When the dvm changes, it recomputes the center frequency and sends it to the readout. When a front panel control is changed, the program jumps to reload all other interfaces. A condensed block diagram of the program is shown in Figure 2-6.

CENTER FREQUENCY DIGITAL VOLTMETER

The center frequency dvm is a modified dual slope analog-to-digital converter which digitizes the Tune Volts from the front panel control. The digital information is sent to the microcomputer for use in computing center frequency.

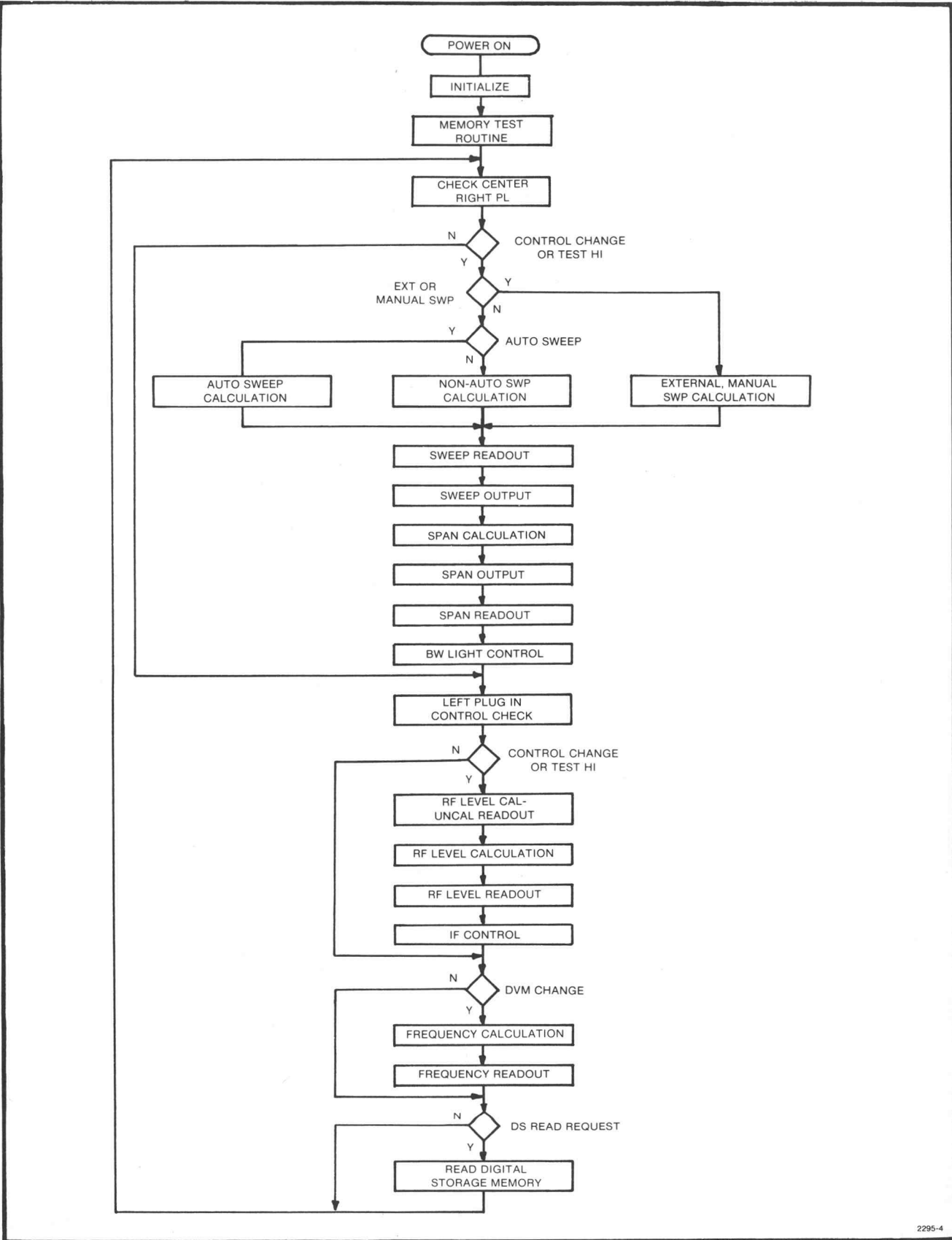

Figure 2-6. Control Program Simplified diagram.

2295-4

U450 is a differential-input buffer for the Tune Volts. Adjustments R455 (Gain) and R475 (Offset) allow for calibration of the converter.

U470 is the dual-slope integrator. The slope of negative-going ramp at the output of U470 is determined by the magnitude of the current resulting from the Tune Volts input. The slope of the positive-going ramp is determined by the difference between a reference current (generated by U455 and U460) and the signal current. VR500 is the source for the reference current, as well as for an offset current which is summed with the signal current.

U490, U510D, and U480A form an 80,000 count counter which controls the operation of the converter. The clock for the counter is Q530, Q535, and associated circuitry. The counter runs cyclically. When it reaches 0, the output of U525E switches a diode switch (CR466, CR468, and CR476) to turn on the reference current, and the output of U470 ramps positive until it exceeds the threshold of U475. The output of U475 then resets the diode switch, turning off the reference current. The integrator output then ramps downward for the remainder of the cycle. When the output of U475 goes high, it also loads the count within the counters of U490 into latches in the same IC. This count is proportional to the duration of the upward ramp, and hence to the Tune Volts input. The maximum value of this count is approximately 22,000, so no information is lost by not latching the output of U480A.

The microcomputer reads the information from the latches in U490 asynchronously with the operation of the converter. It is necessary that the data in the latches not be changed during the readout; hence, the microcomputer begins reading only during the downward portion of the ramp. As the minimum duration of the upward ramp is approximately 2,000 counts, the reading operation can be completed before a new count is loaded, even if it is begun just before the ramp switches. The ramp polarity signal is coupled to the microcomputer through the 8-bit of the I/O bus when port 10 is addressed.

The data is read from the latches as five BCD digits, sequenced onto the data bus by a multiplexer internal to U490. Before starting to read data, the microcomputer must know that the scanner is on the least significant digit. This information is transferred from the Q_A output of U490 through U540A to the 1-bit of the status port. If necessary, the microcomputer steps the scanner by writing to the status port.

When the scanner is in the right position, the microcomputer switches to port 11 and reads the BCD digits, writing to port 11 to step the scanner after each read. The data appears on the bus in complemented form.

CENTER FREQUENCY AND CRT READOUT BOARDS

The readout boards interface the microcomputer bus to the mainframe readout system, enabling the 7L18 to display its control settings on the crt. These boards also drive the front panel CENTER FREQUENCY and REFERENCE LEVEL LED displays.

Figure 2-7 shows the physical location of the different blocks of the 7L18 readout system. The shift registers and their controls are identical for the Center Frequency and Reference Level portions of the circuit. All three switch logic blocks are different internally since they must display different types of data. The specific codes required to setup the displays are shown in Table 2-1. The specific signal lines that connect to these two boards are shown in Table 2-2.

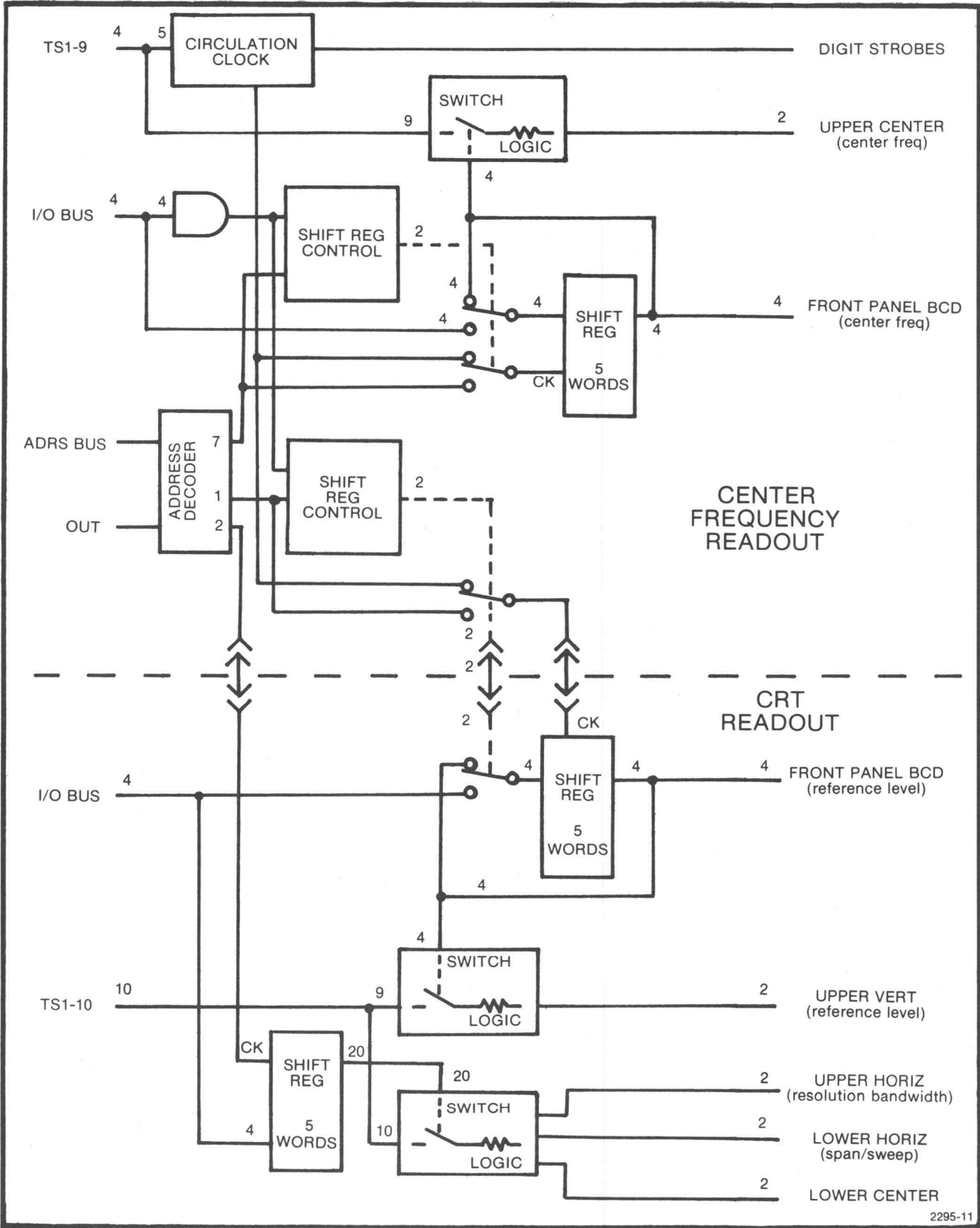

2295-11

Figure 2-7. Readout block diagram.

Table 2-1
DISPLAY CODES

Port	Display	Function	Contents	Word	
7	Center Frequency (loaded in MHz, decimal point to display GHz)	Reset to load mode	15	1	
		Digits 0—9	BCD code	2-6	
		Space (Blank)	12	2-6	
1	Reference Level (dBm)	Reset to load mode	15	1	
		Calibrated	4	2	
		< uncalibrated	5	2	
		> uncalibrated (UNCAL lit)	6	2	
		Digits 0—9	BCD code	3-6	
		+	10	3-6	
		-	11	3-6	
		Space	12	3-6	
2	Resolution Bandwidth	3 MHz RES	8	1	
		300 kHz RES	7	1	
		30 kHz RES	5	1	
		3 kHz RES	4	1	
		300 Hz RES	3	1	
		30 Hz RES	1	1	
		Span/Sweep Span (Span displayed unless in 0 span, when sweep displayed)	0 Hz	display	sweep
			200 Hz	2,2, 8	2,3,4
			500 Hz	4,2, 8	2,3,4
			1 kHz	1,0, 9	2,3,4
			2 kHz	2,0, 9	2,3,4
			5 kHz	4,0, 9	2,3,4
			10 kHz	1,1, 9	2,3,4
			20 kHz	2,1, 9	2,3,4
			50 kHz	4,1, 9	2,3,4
			100 kHz	1,2, 9	2,3,4
			200 kHz	2,2, 9	2,3,4
			500 kHz	4,2, 9	2,3,4
			1 MHz	1,0,10	2,3,4
			2 MHz	2,0,10	2,3,4
			5 MHz	4,0,10	2,3,4
			10 MHz	1,1,10	2,3,4
			20 MHz	2,1,10	2,3,4
			50 MHz	4,1,10	2,3,4
			100 MHz	1,2,10	2,3,4
			200 MHz	2,2,10	2,3,4
		500 MHz	4,2,10	2,3,4	
		IDENTIFY	0,0,12	2,3,4	
		MAX	8,0, 2	2,3,4	

Table 2-1 (cont)
DISPLAY CODES

Sweep External (no display)	0,0, 0	2,3,4
Manual (no display)	0,0, 0	2,3,4
Auto (display calculated sweep)		
20 s	2,1, 4	2,3,4
10 s	1,1, 4	2,3,4
5 s	4,0, 4	2,3,4
2 s	2,0, 4	2,3,4
1 s	1,0, 4	2,3,4
500 ms	4,6, 4	2,3,4
200 ms	2,6, 4	2,3,4
100 ms	1,6, 4	2,3,4
50 ms	4,5, 4	2,3,4
20 ms	2,5, 4	2,3,4
10 ms	1,5, 4	2,3,4
5 ms	4,4, 4	2,3,4
2 ms	2,4, 4	2,3,4
1 ms	1,4, 4	2,3,4
500 μ s	4,10,4	2,3,4
200 μ s	2,10,4	2,3,4
100 μ s	1,10,4	2,3,4
50 μ s	4,9, 4	2,3,4
20 μ s	2,9, 4	2,3,4
10 μ s	1,9, 4	2,3,4
5 μ s	4,8, 4	2,3,4
2 μ s	2,8, 4	2,3,4
1 μ s	1,8, 4	2,3,4

Table 2-2
INTERFACE CHART

Center Frequency Readout		CRT Readout		
Function	Level	Pin	Function	Level
I/O 8	5 V logic in	1	REF LVL C	0 to - mA out
I/O 4	5 V logic in	2	REF LVL R	0 to - mA out
I/O 2	5 V logic in	3	LWR CTR R	0 to - mA out
I/O 1	5 V logic in	4	LWR CTR C	0 to - mA out
CF BCD 4	5 V logic out	5	SPAN/SWEEP R	0 to - mA out
CF BCD 2	5 V logic out	6	SPAN/SWEEP C	0 to - mA out
CF BCD 1	5 V logic out	7	RES BW C	0 to - mA out
CF BCD 8	5 V logic out	8	RES BW R	0 to - mA out
+5 V	5 V supply	9	n.c.	
GND	common	10	REF LVL BCD 8	5 V logic out
-15 V	-15 V supply	11	REF LVL BCD 4	5 V logic out
REF LVL LOAD	5 V logic out	12	REF LVL BCD 2	5 V logic out
REF LVL RUN	5 V logic out	13	REF LVL BCD 1	5 V logic out
DIGIT 5 (MSD)	5 V logic out	18	REF LVL CLOCK	5 V logic in
DIGIT 4	5 V logic out	19	n.c.	
DIGIT 3	5 V logic out	20	"-" SIGN	5 V logic out
DIGIT 2	5 V logic out	21	REF LVL RUN	5 V logic in
DIGIT 1 (LSD)	5 V logic out	22	REF LVL LOAD	5 V logic in
OUT	5 V logic in	26	I/O 1	5 V logic in
ADR 1	5 V logic in	27	I/O 2	5 V logic in
ADR 8	5 V logic in	28	I/O 4	5 V logic in
ADR 4	5 V logic in	29	I/O 8	5 V logic in
ADR 2	5 V logic in	30	CRT LOAD	5 V logic in
CRT LOAD	5 V logic out	35	TS 1	-15 V pulse in
REF LVL CLOCK	5 V logic out	36	TS 2	-15 V pulse in
TS 5	-15 V pulse in	37	TS 3	-15 V pulse in
TS 6	-15 V pulse in	38	TS 4	-15 V pulse in
TS 4	-15 V pulse in	39	TS 5	-15 V pulse in
TS 3	-15 V pulse in	40	TS 6	-15 V pulse in
TS 2	-15 V pulse in	41	TS 7	-15 V pulse in
TS 1	-15 V pulse in	42	TS 8	-15 V pulse in
TS 7	-15 V pulse in	43	TS 9	-15 V pulse in
TS 8	-15 V pulse in	44	TS 10	-15 V pulse in
TS 9	-15 V pulse in	45	+5 V	5 V supply
CTR FREQ C	0 to -1 mA out	46	GND	common
CTR FREQ R	0 to -1 mA out	47	-15 V	-15 V supply

The circulation clock strobes the center frequency and reference level shift registers to circulate their data. This clock also produces the digit drive signals to tell the front panel displays which digit to display the current data in. These digit strobes are generated by a divide-by-five circuit that is derived from the shift register clock. To allow compatibility with the mainframe readout system, the clock must circulate the registers in synchronism with the readout time slot signals. When no time slot signals are being received, an internal clock is allowed to run at about a 5 kHz rate, about the same rate as the time slot signals. When readout signals are received, this internal clock is stopped. A clock signal is derived from the time slot signals, ensuring proper synchronization with the time slot signals.

The address decoder monitors the address bus and the OUT line to determine when data is being sent to the readout system. The Center Frequency has been assigned to port 7; the Reference Level to port 1; the Resolution Bandwidth and Span/Sweep to port 2.

Since both the center Frequency and Reference Level readout circuits are identical except for the switch logic, the following description serves both. The shift register control basically controls a switch that determines whether the five-word shift register is to load new data or circulate the currently stored data. When a 15 is received on the I/O bus concurrent with an address strobe from the address decoder, the control throws the switch to the load position. After five additional words, none of which is of value 15, have been received and loaded in the shift register, the control is ready to throw the switch to the circulate position. In order for the proper data to be displayed in the proper position, the throw of the switch is delayed until the time the first character is normally displayed.

Since the Resolution Bandwidth and the Span/Sweep are displayed only on the crt, no circulation clocks are needed. When data is received from the I/O bus, the address strobe from the address decoder shifts the current data down one position and loads the new data at the top of the register. Normally five words are received during a short period of time to help prevent the display from blinking. The data is updated only when the front panel switches are changed.

The blocks labeled Switch Logic are basically switches that choose the proper currents to tell the mainframe which character to display. The currents are generated when a time slot line is pulled to -15 volts by the mainframe.

DIGITAL STORAGE



The 7L18 has built-in digital storage, so a storage mainframe is not required. When digital storage is selected, the display is a presentation of a large number of memory locations, which stay at previously determined amplitude until updated. An intensified marker shows the point at which the memory is being updated.

Graphical presentation of mathematical functions or data is a common practice. One class of graphs are those which have a single Y value for each X coordinate. An alternate representation for a graph would be a two-column table, where the X coordinates and Y value for each X coordinate were simply listed. If the first X coordinate and the spacing between X coordinates were known, then the two-column table could be reduced to a single column and the X coordinate would be implied by the position of the Y value in the table. This is the essence of digital storage. The vertical analog voltage (Y value) is converted to a binary number and stored in a table. The location in the table is determined by the analog sweep voltage (X coordinate). Once the table is created, the function can be recreated by converting the table's values and table positions to analog voltages.

This digital storage system has two tables (memories) labeled A and B. Table B (B memory) is always updated on every sweep; Table A (A memory) is not changed if SAVE A control line is true. There are 512 A values and 512 B values. The spacing between X coordinates is the same in each table, but the origin of B is shifted such that the X coordinates of A and B are interlaced.

When the stored digital data is recreated, the user has the option of displaying either A, B, or both. If SAVE A is true, when both tables in memory are displayed, then all saved data in A is displayed and all of updated data in B is displayed alternately. When SAVE A is not selected, then sequential interlaced values of A and B are displayed as one trace with 1024 positions. A third trace option, called B-A is also available. The displayed values are the difference between the B and A values for the same X coordinate.

Since a function is continuous and a table has values for discrete X coordinates, an algorithm is used to determine the Y value to be stored for a particular X value. This system allows the user to select one of two methods for determining Y values: peak or average. The Y analog signal is continually being sampled. The number of samples depends upon the speed of the analog sweep voltage. For one X coordinate, there are always at least two samples, and there may be as many as 2^{17} . From this set of samples the user can select the largest sample value, called peak value, or the mean of all the samples, called average value. This selection is controlled by the PEAK/AVERAGE logic signal. This logic signal is created by comparing a dc level with the analog vertical signal input. The dc level is set with the front panel PEAK/AVERAGE control; when the input is below the level, average is chosen; when the input is above the level, peak is chosen. This dc level appears on the display as a positionable horizontal line. The logic line, named "cursor" is created by switching the dc level to the analog output during the marker cycle.

Superimposed on the cursor is an intensified spot or Update Marker, which shows the X-coordinate at which new Y values are being computed. Update Marker is formed by comparing the analog sweep input to the display analog X output, and forcing the sweep to pause, increasing the marker intensity.

The heart of the digital storage system is two ICs, U3526, and U3585. U3526 contains the vertical acquisition, vertical display, peak detection, signal averaging, Z axis blanking, and special Y-value processing circuits. U3585 contains the horizontal acquisition address counter, horizontal display counter, 10 bit RAM address multiplexer, and a programmable logic array system control matrix. External to the two chips are two eight-bit digital-to-analog converters, two ten-bit digital-to-analog converters, one ten-bit latch, 8k bits of random access memory, and all required analog functions. Timing is controlled by clock pulses arriving at pin D8 from the microprocessor board at about a 1 MHz rate.

Vertical Section. The vertical analog voltage is converted to a Y value binary number using an eight-bit successive approximation register U4710. Eight clock cycles are required to perform an analog-to-digital conversion. For one clock between each conversion the successive approximation register produces a low-going pulse called SYNC; most functions are related to this synchronizing pulse.

The averaging circuit, contained within U3526, has three distinct parts: (1) the accumulation of all Y values for a particular X coordinate (numerator); (2) the number of samples comprising the numerator (denominator); and (3) the subtract-and-shift circuit which performs the division.

Another section of U3526 compares incoming Y values with those previously stored for each X coordinate, and retains the larger. A built-in multiplexer then selects either the average or the peak value to be routed to the memory, based on the $\overline{\text{PEAK/AVG}}$ signal.

When the MAX HOLD logic signal is high, U3526 stores in memory the larger of the current memory value or the previously-selected peak/average value, for each X coordinate.

All data enters and leaves the memory serially. Data read from the memory enters an eight-bit shift register, and, timed by $\overline{\text{SYNC}}$, is transferred to the vertical display output latch. Since this shift register is also used for other purposes, the DISPLAY ENABLE signal prevents non-display information from being transferred to the output latches. One example of other data moving through this register is during a B-A display, described below.

When B-A is selected, the actual expression implemented is $B-A+K$, where K is a serial input external constant specified by the user. This permits placing the $B-A=0$ point at any level on the display (refer to Section 3). To avoid confusion, the display is blanked when $B-A+K$ is off screen.

U3526 contains a three-bit synchronous counter which identifies which bit of the eight-bit vertical value is to be read or written by the memory. This is the only memory addressing done by the device; all other addressing is under the control of U3585.

Horizontal Section. The analog sweep voltage is converted to an address for the current table value by the use of a ten-bit tracking analog-to-digital converter. As the sweep moves to the right, the counter increments; as the sweep retraces, the counter decrements. The increment clock is $\overline{\text{SYNC}}$; the decrement clock is the basic 1 MHz system clock. When the SAVE A line is high, the counter skips every other binary number; thus, only B coordinates appear as addresses.

The display is produced by reading from memory the Y value and converting it and its X location to analog voltages. The counter which cycles through all the X locations is located on U3585. As the counter cycles, it may be interrupted by a START DIVIDE signal; a multiplexer switches the memory address from display to acquisition.

The "intelligence" for the system is contained in a ROM, which performs several functions:

- a. it controls which trace is going on screen;
- b. it decides when to switch from read to write;
- c. it generates the B-A coordination signals with U3526;
- d. it controls the incrementing of the display counter;
- e. it handles requests for the memory bus.

When an external device wishes to read or write memory contents, it must request permission by allowing BUS REQUEST to go high. U3585 will then seek an eight-cycle clock sequence which will not interfere with its functions. When that time becomes available, U3585 pulls BUS REQUEST low, signaling the start of a request cycle. For the next eight clock cycles, all address lines and the read/write line go to the high-impedance tristate mode.

When a display mode is not selected, it is skipped by U3585. The highest possible refresh rate is obtained at this time.

SERVICE INFORMATION

GENERAL

When the 7L18 is on extender cables, most minor adjustment controls are accessible from the top of the instrument without removing individual modules. For access to less frequently used adjustments, or for component replacements and major repairs, the 7L18 is hinged at the back between the vertical and horizontal plug-in sections. (We identify the sections as vertical and horizontal because they plug into the vertical and horizontal deflection compartments of an oscilloscope mainframe.) Two screws must be removed to separate these sections. Access to the rear of the hinged horizontal (wider) front panel is gained by removing another two screws and unhooking the rear end of the latch spring. Even with the hinged sections fully extended, the 7L18 is fully operational when connected to the mainframe with the extender cables.

The horizontal section consists of stacked, interlocking extrusions, each of which provides good shielding between adjacent functional modules. Any module can be removed without disturbing the structural or functional integrity of the remaining modules (refer to Figure 3-1). The module extenders will allow any module to function in an extended position for service or adjustment. The module circuit boards can be removed from the extrusions by removing their securing screws. Virtually all other circuit boards (which should require little or no servicing) are accessible by simply removing a cover plate.

NOTE

Disassembly of some of the modules, and the front panel assemblies, is a complex procedure and in some cases requires special tools. Since these less-likely procedures are beyond the scope of this manual at present, we recommend returning the instrument to Tektronix should service be necessary.

The phase lock system housing contributes greatly to the 7L18 stability. Four crystal-controlled oscillators are completely rf-isolated to ensure spurious-free response, yet are in close proximity to minimize cable losses and interactions with other functions. Other elements of the system are mounted back-to-back in the remaining compartments. All compartments are enclosed on both sides by mu-metal plates, and all interconnections between front and rear sides of the extrusion are made by feedthroughs rather than cables. If components in this housing are accessed, be sure that the shields and covers are properly reinstalled.

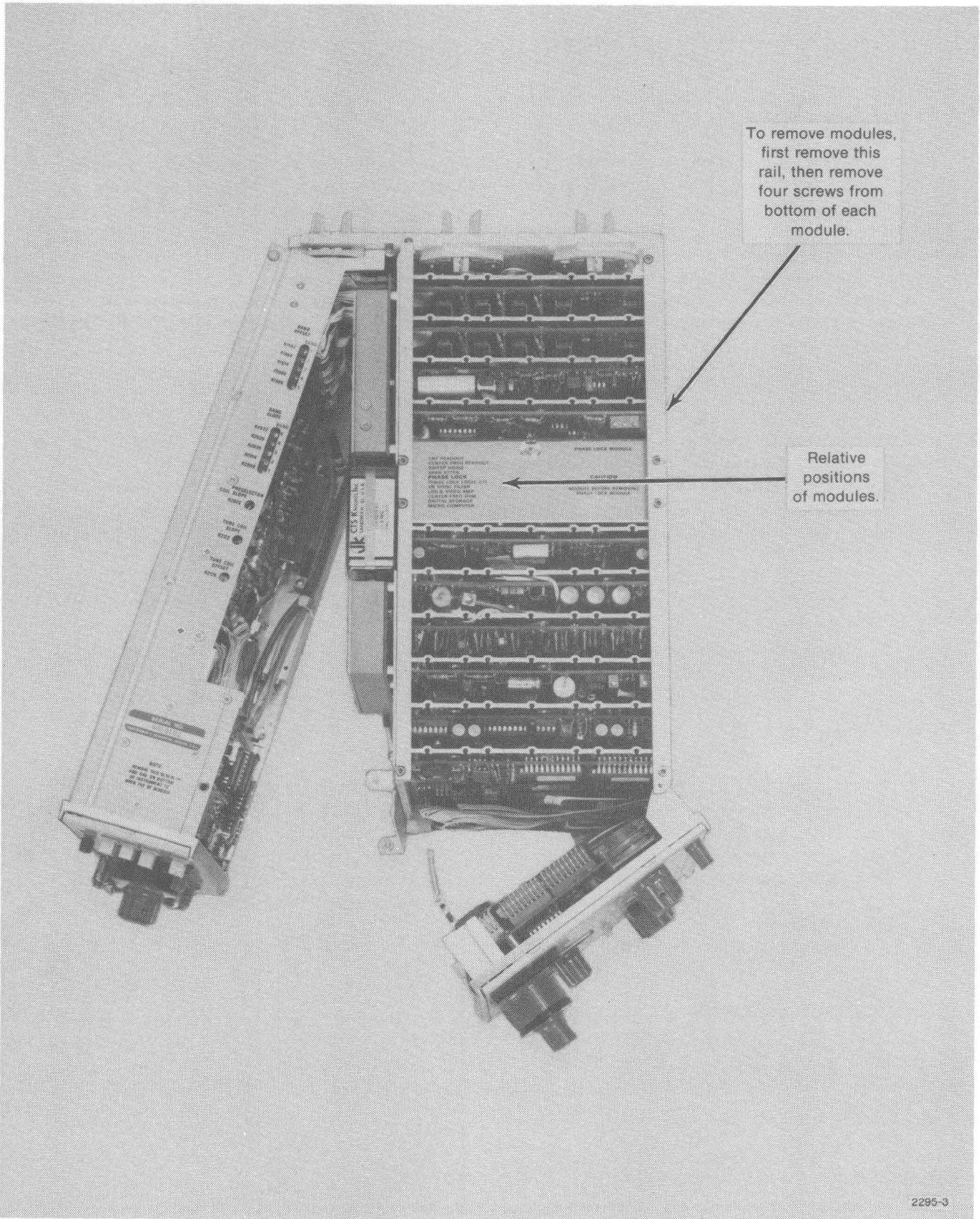

Figure 3-1. 7L18 Extended for servicing.

TEST FIXTURES

The following test fixtures allow operation of the 7L18 out of the mainframe, with some of its modules extended if desired, for calibration or troubleshooting purposes. In addition to this equipment, an extensive array of sophisticated instrumentation may be required for some troubleshooting or calibration procedures, both of which are beyond the scope of this interim manual at present. We therefore recommend that the instrument be returned to Tektronix for **all** repair or calibration.

Flexible Plug-in Extenders (three required)	067-0616-00
---	-------------

NOTE

The plug-in extenders above may need minor modification in order to fit properly on some spectrum analyzers. Consult a Tektronix Service Center for procedure if necessary.

Phase Lock Module Extender	067-0868-00
Standard Module Extender	067-0869-00
Narrow Module Extender	067-0870-00
7L18 Service Kit (includes all three extenders listed above)	006-2487-00

SETTING THE CONSTANT K

When the B-SAVE A display mode is selected, the constant K describes the position of the trace vertically when B equals A. The range of K is from 0 to 255, and is factory set to 192. (Zero is below the baseline, but the trace is clamped at baseline in the Log Amplifier. 255 is off the top of the screen.)

Figure 3-2 shows the positions and relative values of the selection resistors, R3561 through R3568. The numbers given are actually exponents of two, and are selected by setting the respective resistor to the +5 V bus. For example, $192 = 2^7 + 2^6 = 1\ 100\ 000_2$. Therefore, R3564 and R3568 are connected to +5 V; the rest are connected to ground (refer also to Digital Storage Diagram 25).

ELAPSED TIME METER

The 7L18 elapsed time meter is located on the bottom of the mother board. The meter is activated whenever power is applied to the instrument, and has a total recording time of 5000 hours. After this time has elapsed, the meter can be replaced if desired.

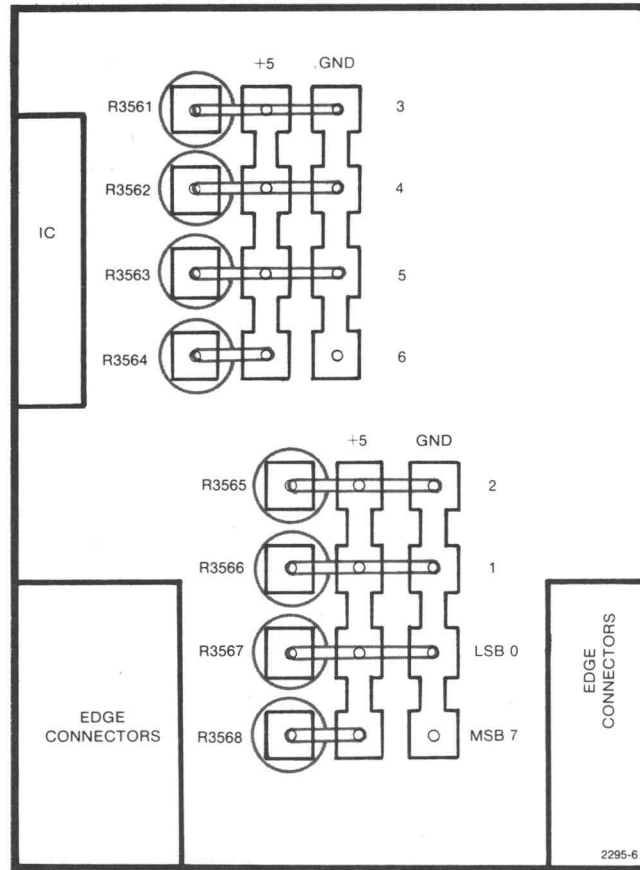

Figure 3-2. Locations and relative values of trace positioning resistors in B-SAVE A mode.

LOSS OF SIGNALS ON DISPLAY

If the analyzer seems to be working properly but no signal appears, check the two fuses located in the First LO and Preselector Driver board. To do this, open the RF Module, remove the fuses, and test them with an ohmmeter. See Figure 3-3.

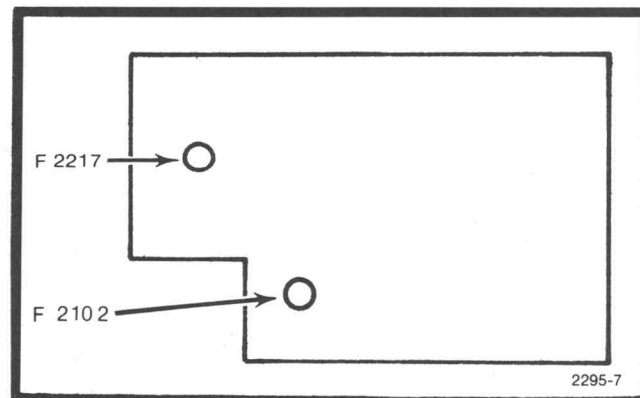

Figure 3-3. Location of F2217 and F2102 on First LO and Preselector Driver Board.

REPLACEMENT OF YIG OSCILLATOR

Two selected resistors, R2270 and R2276, located on the First LO and Preselector Driver board (diagram 13), may need to be replaced if the YIG oscillator is replaced. These resistors control the voltage required for the YIG oscillator to be within its second harmonic specification; this voltage is marked on the YIG oscillator housing. Refer to Table 3-1 to determine the resistor values, then replace the resistors with 1%, T0, 1/8 W types.

Table 3-1

Voltage	R2270	R2276
11.0 to 11.4	14 k Ω	3.01 k Ω
11.5 to 11.9	16.5 k Ω	2.94 k Ω
12.0 to 12.4	20 k Ω	2.87 k Ω
12.5 to 12.9	24.9 k Ω	2.8 k Ω
13.0 to 13.4	32.4 k Ω	2.8 k Ω
13.5 to 13.9	45.3 k Ω	2.74 k Ω
14.0 to 14.5	76.8 k Ω	2.67 k Ω
14.6 to 15.0	not installed	2.61 k Ω



CALIBRATION

Introduction

This section consists of two parts: a Performance Check and a listing of Adjustment Procedures. Part 1 is used to determine the instrument's functional condition and to verify its performance with respect to given specifications. Part 2 provides the adjustment instructions for returning out-of-tolerance performance to specifications.

Do not arbitrarily perform an adjustment step without first establishing a need with the Performance Check; some adjustments may interact with the performance of other circuits. After performing any adjustment, always conduct a Performance Check to verify conformance with specifications.

TABLE OF CONTENTS

	Page
INTRODUCTION	4-1
Equipment Required for Calibration (Table 4-1)	4-2
PART 1 PERFORMANCE CHECK	
List of Performance Checks (Table 4-2)	4-4
List of Figures (Table 4-3)	4-5
Performance Check Record	4-6
Performance Check Steps	4-7
PART 2 ADJUSTMENT PROCEDURES	
List of Adjustment Steps (Table 4-7)	4-24
Instrument Construction	4-24
Flexible Plug-in Extenders and Module Assembly Extenders	4-25
Adjustment or Component Access	4-25
Microcomputer Component Access	4-28
Adjustment Procedures	4-31

Equipment Required for Calibration

The equipment listed in Table 4-1 is required for the Calibration of a 7L18 Spectrum Analyzer. The characteristics specified are minimum requirements. Substitute equipment must meet or exceed these characteristic requirements.

All items manufactured by Tektronix, Inc. may be ordered through your local Tektronix Field Office or representative.

Table 4-1
EQUIPMENT REQUIRED FOR CALIBRATION

Equipment or Test Fixture	Characteristics Required	Type or Model Recommended
PERFORMANCE CHECK		
7000-Series Oscilloscope with read-out	7000-Series interface with frequency bandwidth ≥ 50 MHz.	TEKTRONIX 7000-Series mainframe.
Test Oscilloscope	Vertical sensitivity, 50 mV to 5 V/Div.	Any TEKTRONIX 7000-Series oscilloscope with plug-in units for a real-time display such as: a. 7A11, Single Trace Amplifier b. 7B50A, Time Base
Time Mark Generator	Marker outputs, 1 s to 1 μ s; accuracy, 0.001%.	TEKTRONIX TM 501 and TM 500-Series Power Module.
Function or Signal Generator	1 Hz to 3 MHz.	TEKTRONIX FG 503 Function Generator and TM 500-Series Power Module.
Variable Voltage Source	0 to ± 12 V dc.	TEKTRONIX PS 501-1 Power Supply and TM 500-Series Power Module.
Digital Frequency Counter	10 Hz to 1 GHz sensitivity, ≤ -35 dBm.	Hewlett Packard Model 5340A.
Signal Generator(s)	800 MHz to 4500 MHz with output power \geq dBm.	Hewlett Packard Model 8614A. Hewlett Packard Model 8616A.
Sweep Oscillator	Minimum coverage, 2 GHz to 18 GHz; desirable coverage, 1.5 GHz to 18 GHz.	Hewlett Packard Model 8620C mainframe and Hewlett Packard Model 8629A Sweep Oscillator.
Power Meter with Power Sensor	Measures from -60 to -20 dBm full scale; frequency range, dc to 18 GHz.	Hewlett Packard Models 436A and 8482A.
Step Attenuators	Range, 0—110 dB in 10 dB steps; accuracy, ± 0.1 dB; frequency range, dc to 18 GHz.	Step attenuator such as Hewlett Packard Model 8496B calibrated by precision standard attenuators such as Weinschell Model AS-6.
2 GHz Bandpass	Filter must have a -40 dB response at ± 500 MHz.	
Harmonic Modulator		Tektronix Calibration Fixture, Part No. 067-0640-00.
N Male to BNC Female		Tektronix Part No. 103-0045-00.

Table 4-1 (cont)

Equipment or Test Fixture	Characteristics Required	Type or Model Recommended
ADJUSTMENTS		
All the items listed above plus the following are required for the adjustment procedures.		
Spectrum Analyzer	Frequency range to 2.0 GHz.	TEKTRONIX 7L18.
Signal Generator(s)	10 MHz to 520 MHz with calibrated output level to 0 dBm.	Hewlett-Packard Model 8624A.
Return Loss Bridge	10 MHz to 1 GHz, 50 ohms.	Wiltron VSWR Bridge Model 62NF50.
3 dB Miniature Attenuator	Frequency to 5 GHz; 5 mA connectors.	NARDA Model 4779 with male-to-male connectors.
Comb Generator	+10 dBm at 1 GHz	Tektronix Calibration Fixture, Part No. 067-0885-00.
DC Block		Tektronix Part No. 015-0221-00.
BNC Female-to-Selectro male		Tektronix Part No. 013-0180-00.
BNC-to-Selectro Adapter		Tektronix Part No. 175-0419-00.
BNC Female-to-SMA male		Tektronix Part No. 015-1018-00.
8" cable Tip Plugs to BNC		Tektronix Part No. 175-1178-00.
8" Coaxial Cable		Tektronix Part No. 012-0208-00.
8" Cable BNC to Harmonica		Must be fabricated; see drawing below.
Tuning Screwdriver		
Screwdriver, Flat		6" with 1/8" blade.
Screwdriver, Phillips type		No. 1.
Allen Wrenches		3/32", 5/64", 7/64".

PART 1—PERFORMANCE CHECK

The tolerances listed with each Performance Check Step are taken from the instrument specifications as described in Section 1 of this manual. Table 4-2 is a listing of the Performance Check steps.

Table 4-2
LIST OF PERFORMANCE CHECKS

Performance Check Step	Page
1. Check Calibrator (CAL OUT) Frequency	4-7
2. Check Calibrator (CAL OUT) Output Level	4-7
3. Check RF Attenuator Accuracy	4-8
4. Check LOG 2 dB/DIV and LIN Display Modes	4-9
5. Check Frequency Readout Accuracy	4-10
6. Check Resolution Bandwidth and Shape Factor	4-11
7. Check the REF VARIable and Gain Selector Range	4-11
8. Check Sensitivity	4-12
9. Check Stability	4-13
10. Check Incidental FM	4-14
11. Digital Storage	4-15
12. Check Frequency Response	4-15
13. Check Intermodulation Distortion	4-16
14. Check Triggering Operation and Sensitivity	4-17
15. Check External Horizontal Input Voltage Requirements	4-18
16. Check Video Output Level	4-19
17. Check Frequency Span Accuracy and Linearity	4-21
18. Check Sweep Rate	4-22
19. Check Preselector's Ultimate Rejection	4-23

Table 4-3
LIST OF FIGURES

Fig. No.	Description	Page
4-1	Calibrator Output Level Test Setup	4-7
4-2	RF Attenuator Test Setup	4-9
4-3	Display Mode Test Setup	4-10
4-4	Display Mode Log	4-11
4-5	Display Mode 10 dB/DIV	4-11
4-6	Measuring Average Noise Level as an Indication of Sensitivity	4-12
4-7	Measuring Stability Using MAX HOLD Feature of 7L18	4-13
4-8	Measuring Incidental FM	4-14
4-9	Using Digital Storage Feature to Measure Differential Between Two Displays	4-15
4-10	Frequency Response Test Setup	4-16
4-11	Intermodulation Distortion Check Test Setup	4-17

Table 4-3 (cont)

Fig. No.	Description	Page
4-12	Intermodulation Products (Distortion)	4-17
4-13	Triggering Operation and Sensitivity Test Setup	4-18
4-14	External Horizontal Input Voltage Test Setup	4-19
4-15	Video Output Level Test Setup	4-20
4-16	Video Output Test Waveshape	4-20
4-17	Freq. Span/Div Test Setup	4-21
4-18	Sweep Rate Test Setup	4-22
4-19	7L18 and 7000-Series Oscilloscope with Accessories and Tools used When Making Calibration Adjustments	4-25
4-20	Location of Side Panel and Retaining Rail Screws that must be moved to Gain Access to Calibration Adjustments	4-26
4-21	7L18 Showing how Two Sections are Hinged Together and Separated for Servicing	4-27
4-22	Location of the Hexagonal Head Screws that hold the Plug-in Module Assemblies	4-29
4-23	Location of Front Panel Securing Screws	4-30
4-24	Span Attenuator Test Points and Adjustments	4-31
4-25	Equipment Setup for Calibrating Sweep Timing	4-32
4-26	Time Marks Displayed for Calibrating Sweep Timing	4-33
4-27	Equipment Setup to Adjust and Calibrate Drive to FM Coil of the 1st LO	4-33
4-28	1 MHz Beat Notes as seen on the Display for Calibrating the 1st LO FM Coil Drive	4-34
4-29	Adjustments and Test Point Location on the 1st LO and Preselector Driver . . .	4-35
4-30	Location of Reference Voltage Adjust and P2520	4-36
4-31	Location of Adjustments on Center Frequency DVM	4-37
4-32	Log and Video Amplifier Module on an Extender, Ready for Calibration	4-38
4-33	Log and Video Amplifier Test Points and Adjustments	4-39
4-34	Test Setup for Calibrating Phase Lock Control	4-40
4-35	Phase Lock Logic Control Test Points and Adjustments	4-41
4-36	Test Setup for Calibrating VR Circuits	4-42
4-37	Location of Connectors and Adjustments used When Calibrating the VR Circuits	4-43
4-38	Location of P2484 and 3-Cavity Filter	4-44
4-39	Bottom of 7L18 Showing Location of 510 MHz IF Module	4-45
4-40	Test Setup for Calibrating 510 MHz IF	4-46
4-41	Location of J2824, J2816 and Adjustments on Microcomputer Interface Board .	4-47
4-42	Location of C2821 and C2815	4-48
4-43	500 MHz Calibrator and 2nd Mixer Adjustment and T.P. Locations	4-49
4-44	Digital Storage Calibration Adjustments	4-51
4-45	Location of B—SAVE A Reference Level Positioning Resistor Matrix	4-52
4-46	Adjustments for 300 kHz Filter, 300 kHz Noise Filter, and 3 MHz Noise Filter . .	4-53
4-47	Location of 3 MHz, Three-Section Filter Adjustments	4-54
4-48	Preselector Driver Adjustment and T.P. Locations	4-55
4-49	Vertical Microcomputer Interface Adjustment and T.P. Locations	4-56
4-50	Location of Preselector Driver Slope and Offset Correction Resistors Listed in Table 4-7	4-57
4-51	Test Setup for Calibrating Gain of the Waveguide Bands	4-61

Table 4-4
PERFORMANCE CHECK RECORD

Tektronix, Inc. gives permission to reproduce this Performance Check Record.

Performance Check Step	Tolerance	Reading
1. Check Calibrator Frequency	2.0 GHz \pm 0.01%	_____
2. Check Calibrator Output Level	-30 dBm \pm 0.5 dB	_____
3. Check RF Attenuator Accuracy	\pm 0.3 dB or 1% to 4 GHz; \pm 0.5 dB or 2% to 8 GHz.	_____ _____
4. Check LOG 2 dB/DIV and LIN Display Modes	LOG 2 dB/DIV, \pm 0.4 dB/2 dB; LIN, Linear within 10% full screen.	_____ _____
5. Check Frequency Readout Accuracy	\pm 5 MHz +20% of Span/Div.	_____
6. Check Resolution Bandwidth and Shape Factor	Bandwidth, 3 MHz to 30 Hz \pm 20%; Shape Factor, 12:1 or less—30 Hz; Resolution, 4:1 or less—other Bandwidths.	_____ _____ _____
7. Check RF VARIABLE and Gain Selector Range	VAR, at least 10 dB. Gain, 90 dB in 10 dB steps.	_____ _____
8. Check Sensitivity	-127 to -52 dBm.	_____
9. Check Stability	Within 2 kHz/hr x n, phaselocked. Within 50 kHz/hr x n, not phaselocked.	_____ _____
10. Check Incidental FM	\geq 10 Hz x n, phaselocked. \geq 10 kHz x n, not phaselocked.	_____ _____
11. Digital Storage	no tolerance	_____
12. Check Frequency Response	\pm 5 dB	_____
13. Check Intermodulation Distortion	1.5 to 1.8 GHz, down 70 dB with -40 dBm signals. 1.8 to 18 GHz, down 70 dB with -30 dBm signals.	_____ _____
14. Check Triggering, Sensitivity	Internal, \geq 1 division. External, +0.5 Volt to 50 V peak. (15 Hz—1 MHz).	_____ _____
15. Check External Horizontal Input Voltage Requirement	0 V to 10 V \pm 1 V.	_____
16. Check Video Output Level	500 mV \pm 5%/Div above baseline.	_____
17. Check Frequency Span, Accuracy and Linearity	Accuracy, 5% of Span; Linearity, 5% over center 8 div.	_____ _____
18. Check Sweep Rate Accuracy	Within 5% of sweep rate.	_____
19. Check Preselectors Ultimate Rejection	At least 70 dB less on adjacent band.	_____

DETAILED PERFORMANCE CHECKS

Allow the instrument to warm up at least 30 minutes before proceeding with the Performance Checks.

1. Check Calibrator Frequency (Accuracy, 2.000 GHz \pm 0.01%)

The CAL OUT signal frequency can be measured by connecting it directly to the input of an accurate frequency counter such as the Hewlett-Packard 5340-A Digital Counter. The fundamental frequency of the CAL OUT signal is 500 MHz \pm 50 kHz.

2. Check Calibrator Output Level (-30 dBm \pm 0.5 dB)

The output level of the calibrator can be checked by either of two methods. The first is the power meter method, the second is a comparison method. Both of these are described below:

a. Power Meter Method

1. Connect the test setup as shown in Fig. 4-1. Set the 7L18 front panel controls as follows:

CENTER FREQUENCY	2.0 GHz
Display Mode	LOG 2 dB/DIV
REFERENCE LEVEL	-20 dBm
RF Attenuation	10 dB
TRIGGERING	FREE RUN
Digital Storage	Display A/Display B
Band Selection	1.5—3.5
BASE LINE CLIPPER	Fully cw
TIME/DIV	AUTO
FREQ SPAN/DIV	500 kHz
RESOLUTION BANDWIDTH	3 MHz

NOTE

Insertion loss of the filter, with attenuators (pads), measured at 2.0 GHz \pm 200 MHz, must be determined to within \pm 0.3 dB. Use approximately 3 dB minimum-loss matching pads on either side of the filter to ensure a 50-ohm impedance match.

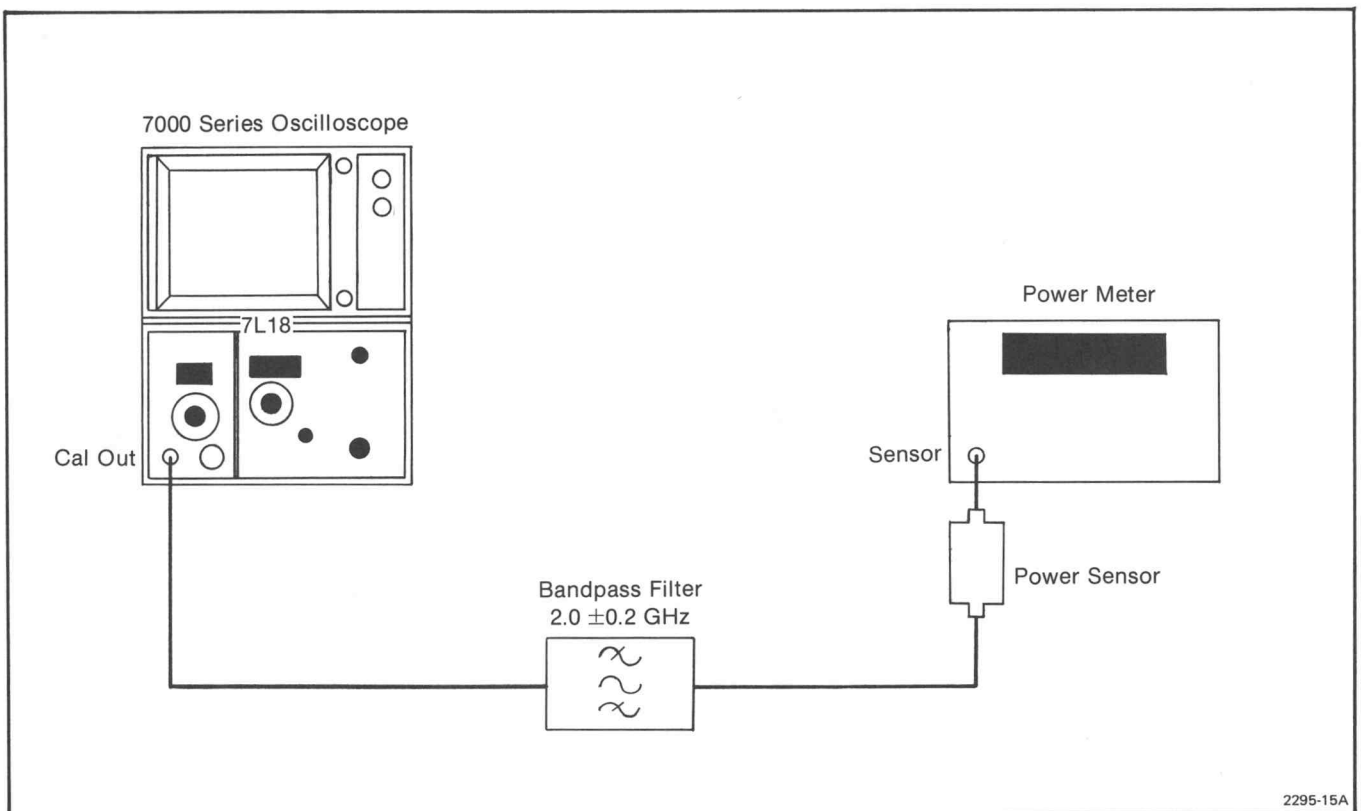

Fig. 4-1. Calibrator Output Level Test Setup.

2. Connect the power meter through the filter to the CAL OUT connector and note the power reading. Power reading plus loss through filter and pads must equal $-30 \text{ dBm} \pm 2.55 \text{ dB}$.

3. Disconnect the test equipment to the 7L18.

b. Signal Substitution Method

NOTE

A power meter is used to verify the output level of the reference signal. Signal Generator harmonic distortion must be less than +30 dB.

1. Apply the output of a 2.0 GHz signal generator, through a 3 dB attenuator, to the power meter and set the output level of the generator for a -30 dBm reading. Then disconnect the meter and (using the same instrument cable and attenuator), apply the calibrated reference signal to the RF INput of the 7L18.

2. Tune the signal to center screen and adjust the REF VAR control to position the top of the signal to a graticule line (2nd or 3rd from the reference-level line). Store the reference display by depressing the SAVE A pushbutton. It may be advisable to decrease the SPAN/DIV to obtain a broad display for a more accurate measurement.

3. Disconnect the -30 dBm reference signal, then apply the 7L18 CAL OUT signal to the RF INput.

4. Depress the B—SAVE A pushbutton and note the displacement of 7L18 CAL OUT signal amplitude from the reference stored in A memory. The displacement of the 7L18 calibrator 2.0 GHz signal level from the reference signal should not exceed $\pm 0.5 \text{ dB}$ (1.25 minor divisions with a 2 dB/DIV display mode).

NOTE

If greater accuracy is desired, the video can be amplified through an external amplifier, such as the 7A15, to increase the vertical sensitivity. This is done by connecting the VIDEO OUT signal to the external amplifier input and selecting the vertical amplification and TIME/DIV values that provide the degree of measurement accuracy desired.

3. Check RF Attenuator Accuracy (Incremental accuracy is $\pm 0.3 \text{ dB}$ or 1% of dB setting, whichever is greater, to 4 GHz; $\pm 0.5 \text{ dB}$ or 2% of dB setting, whichever is greater, from 4 GHz to 18 GHz.)

NOTE

Incremental accuracy tolerance values are not cumulative.

CAUTION

The RF Attenuator accuracy is checked at the factory to ensure that it is within specifications. Any change in attenuation should be large enough to notice during normal operation. If the exact attenuation error of the selector is required, a reference attenuator calibrated by the user or manufacturer to more rigid specifications than the 7L18 must be used. If there is any doubt about the accuracy of the available attenuators, this check should be omitted.

a. Connect the test setup as shown in Fig. 4-2. Set the front panel controls as follows:

CENTER FREQUENCY	2.0 GHz
Display Mode	LOG 2 dB/DIV
REFERENCE LEVEL	-80 dBm
RF Attenuation	0 dB
TRIGGERING	FREE RUN
Digital Storage	Display A/Display B
Band Selection	1.5—3.5
BASE LINE CLIPPER	Fully cw
TIME/DIV	AUTO
FREQ SPAN/DIV	As required
RESOLUTION BANDWIDTH	AUTO

b. Set the step attenuator to 90 dB. Apply a -0 dBm , 2.0 GHz signal from the signal generator through the step attenuator to the RF INput. Tune the CENTER FREQUENCY to the signal and adjust the REF VARIable control for a reference signal amplitude of four divisions.

c. Actuate the DIGITAL STORAGE SAVE A function to store this reference signal level for comparison with subsequent signals.

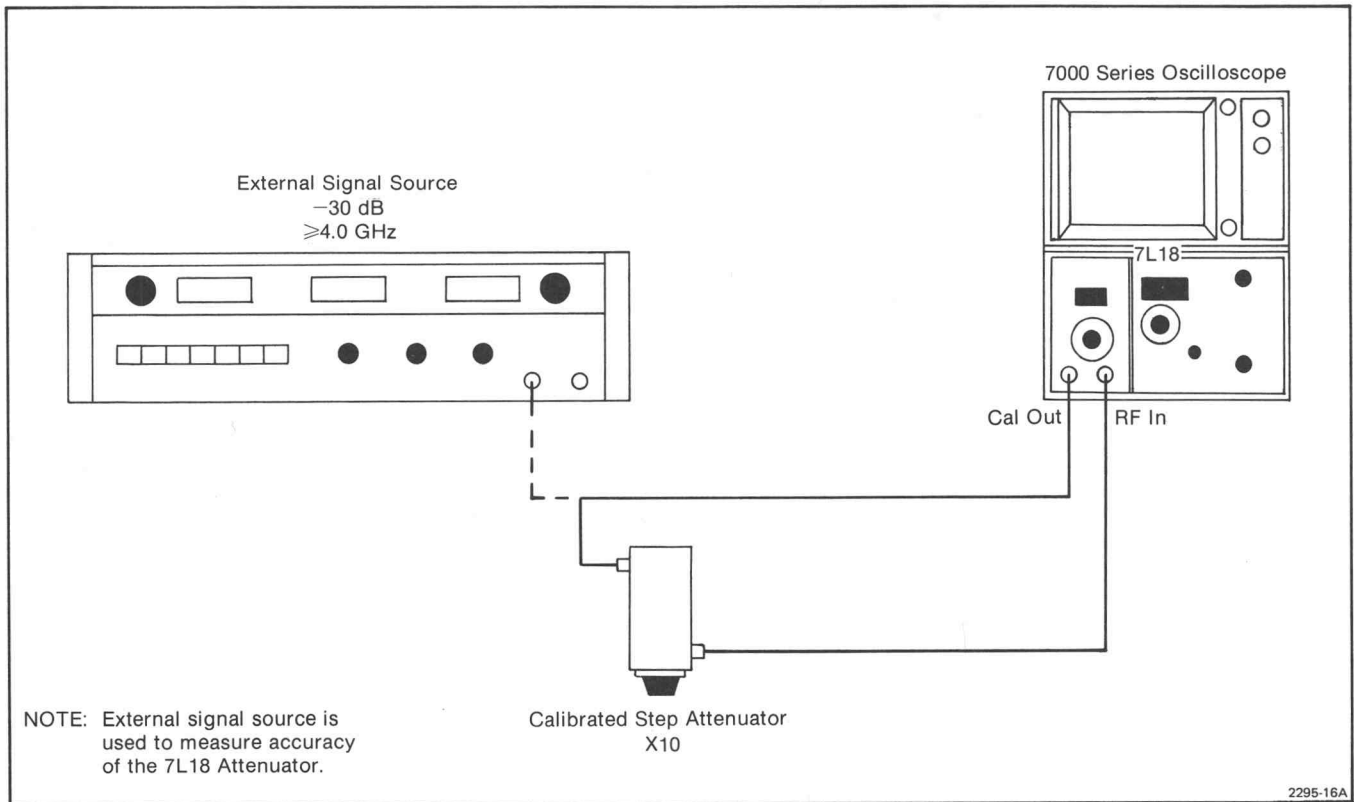

Fig. 4-2. RF Attenuator Test Setup.

d. Check the 7L18 RF Attenuator accuracy by increasing the RF attenuation setting in 10 dB increments while decreasing the reference step attenuator in 10 dB increments. The display amplitude should remain at four divisions ± 0.3 dB or 1% of the RF attenuator setting, whichever is greater.

e. Using the external -0 dBm, 4.0 GHz or higher signal source, repeat this procedure to check attenuator accuracy above 4 GHz.

f. Disconnect test equipment to the 7L18.

4. Check LOG 2 dB/DIV and LIN Display Modes (LOG 2 dB/DIV accuracy is within ± 0.4 dB/2 dB with a maximum error of 1.0 dB over any 10 dB range. LIN provides a linear display within 10% of full screen over the eight-division graticule height.)

The 10 dB/DIV display mode is checked under Operator's Functional Check procedure in the Operators manual.

The performance procedure for the LOG 2 dB/DIV display is presented first followed by the LIN display procedure.

a. LOG 2 dB/DIV Display Mode

1. Connect the test setup as shown in Fig. 4-3. Set the front panel controls as follows:

CENTER FREQUENCY	2.0 GHz
RESOLUTION BANDWIDTH	3 MHz
Display Mode	LOG 2 dB/DIV
FREQ SPAN/DIV	1 MHz
RF Attenuation	10 dB
REFERENCE LEVEL	-30 dBm
Digital Storage	Display A/Display B

2. Tune the CENTER FREQUENCY to the signal. Adjust the REF VARIABLE control for a full-screen display (eight divisions) and switch 2 dB of attenuation into the circuit using the external 1 dB step attenuator.

3. Check that the displayed signal amplitude decreases by 1.0 ± 0.2 division.

4. Increase the step attenuator setting in 2 dB steps and check that the signal amplitude decreases 1.0 ± 0.2 division for each step. Total error over any 10 dB range must not exceed 1.0 dB (± 0.5 div).

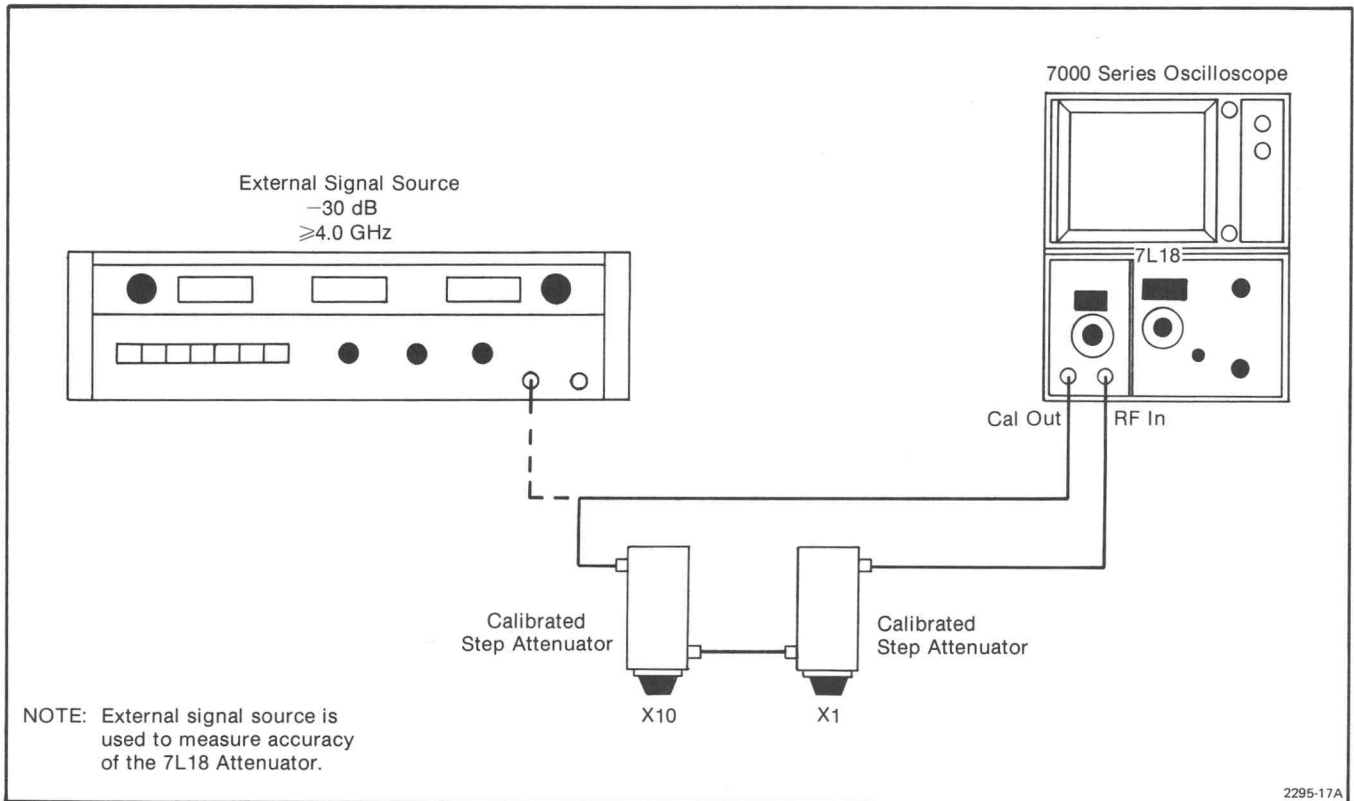

Fig. 4-3. Display Mode Test Setup.

b. LIN Display Mode

1. Reset the RF attenuator and step attenuator to 0 dB.
2. Set the display mode to LIN. Adjust the REF VARIable control for a full-screen display (eight divisions).
3. Switch the external attenuator to 6 dB.
4. Check that the signal amplitude decreases half screen or to 4.0 ± 0.8 division.
5. Increase the external attenuation to 12 dB.
6. Check that the signal amplitude decreases to 2.0 ± 0.8 division.
7. Disconnect the test equipment to the 7L18.

5. Check Frequency Readout Accuracy $\pm(5 \text{ MHz} + 20\% \text{ of Span/Div}) \times n$

NOTE

Due to hysteresis in the tuning system and residual magnetism buildup in the first (YIG) oscillator tuning coils, accuracy of the frequency readout should be checked by approaching each check point from the same direction (low to high). Degauss the tuning coil by pressing the DEGAUSS button within a few megahertz of the check point.

- a. With the Center Frequency readout calibrated at 2.000 GHz as described under Initial Operation and the SPAN/DIV at 1 MHz, tune the CENTER FREQUENCY to center the 2 GHz calibrator marker on screen. Press the DEGAUSS button and adjust PEAKING as the signal is tuned to center screen.

b. Check—the indicated frequency readout. Readout should be within 1.995 and 2.005 GHz or within ± 5.2 MHz of 2.000 GHz.

c. Repeat this procedure to check accuracy of the readout at the 3.0 GHz and 3.5 GHz markers. Accuracy must be within $\pm (5 \text{ MHz} + 20\% \text{ of } 1 \text{ MHz}) \times n$.

d. Switch to Band 2 (2.5—4.5 GHz) and repeat the procedure to check readout accuracy at 3.0 GHz, 3.5 GHz, and 4.0 GHz.

e. Since the other bands operate on harmonics of the oscillator fundamental, accuracy or error will be the same as that measured for the fundamental (bands 1 and 2) multiplied by the harmonic number (n) of the band.

NOTE

In some cases the calibrator harmonic may be very small or missing. Either ignore the check point or try reducing the resolution bandwidth (e.g., 30 kHz) to increase the signal to noise ratio or sensitivity. Adjust PEAKING at each check point.

6. Check Resolution Bandwidth and Shape Factor: (Bandwidth 3 MHz to 30 Hz $\pm 20\%$. Shape factor 12:1 or less for 30 Hz resolution and 4:1 or less for the other bandwidths.)

a. With the 7L18 tuned to the 2.000 GHz Calibrator signal and the Reference Level at -30 dBm, set the FREQ SPAN/DIV at 1 MHz and push the 3 MHz RESOLUTION BANDWIDTH button.

b. Switch the display mode to 2 dB/Div and adjust the REF VAR control so the signal amplitude level is full screen.

c. Measure the 6 dB bandwidth (see Fig. 4-4). Bandwidth must equal 3 MHz ± 600 kHz.

d. Switch the display mode to 10 dB/DIV, FREQ SPAN/DIV to 2 MHz, and the TIME/DIV to 0.5 s.

e. Estimate the -60 dB bandwidth by extending the slope of the response down through the noise level to the -60 dB graticule line. Calculate the shape factor (see Fig. 4-5). Shape factor must equal 4:1 or less.

f. Switch to 300 kHz RESOLUTION BANDWIDTH and 200 kHz Span/Div, then check the bandwidth and shape factor of the 300 kHz filter by repeating the foregoing procedure.

g. Switch to each remaining RESOLUTION BANDWIDTH selections, decrease the FREQ SPAN/DIV selection as necessary to check the bandwidth and shape factor of each selection. Bandwidth must be within 20% of that selected, shape factor is 4:1 or less except the 30 Hz filter which is 12:1 or less.

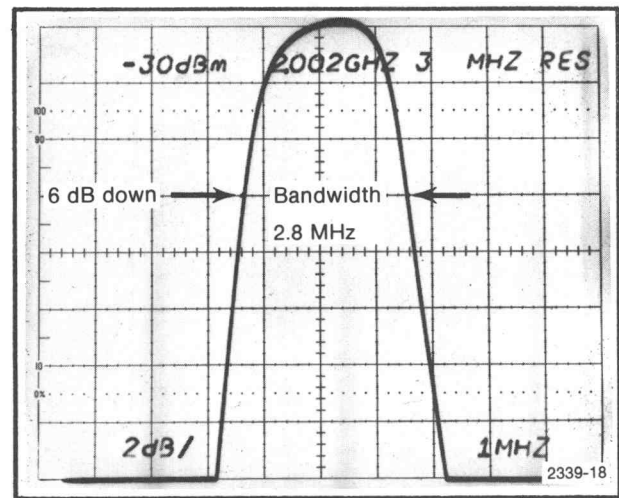

Fig. 4-4. Display Mode Log.

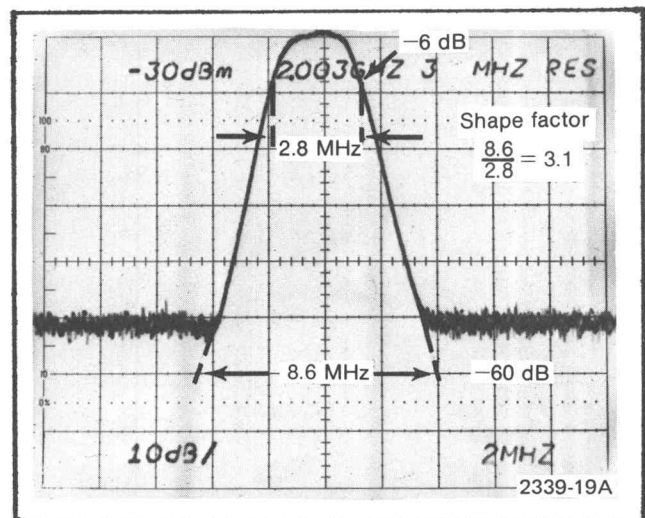

Fig. 4-5. Display Mode 10 dB/DIV.

7. Check the REF VARIABLE and Gain Selector Range: (Variable range is at least 10 dB, IF Gain selector range is 90 dB in 10 dB steps)

a. With the controls set as described in step 6 and the SPAN/DIV at 2 kHz, increase the RF Attenuator setting to 50 dB (Reference Level of $+20$ dBm).

b. Rotate the REF VAR control through its range and note signal amplitude change.

Calibration—7L18 Service

c. Check—REF VAR control range should increase the signal level 10 dB or more. Return the control to its CAL detent.

d. Check—that the IF Gain selector increases the signal amplitude 10 dB \pm 1 dB for each increment in the blue (10 dB/Div) sector and decreases the gain 10 dB \pm 1 dB in the amber (gain reduction) sector. Overall deviation should not exceed 2 dB.

e. Change the display mode to 2 dB/DIV. Insert or add a 20 dB attenuator between the CAL OUT and RF Input connector. Set the RF Attenuator at 20 dB and the Gain selector for -50 dBm reference level readout (last position in the blue sector). Adjust the signal level to a graticule reference line (one or two divisions below center screen) with the REF VAR control.

f. Increase the RF Attenuator and IF Gain selector in 10 dB steps and check that each step of the IF Gain selector, in the 2 dB/Div portion (white sector), increases the calibrator signal amplitude 10 dB \pm 1 dB.

NOTE

Resolution bandwidth and frequency span must be reduced to check the last two Gain selector steps.

g. Return the RF Attenuator to 20 dB, the IF Gain selector for a Reference Level readout of -50 dBm, SPAN/DIV to 2 kHz, and RESOLUTION BANDWIDTH to 3 kHz. Adjust the Calibrator signal amplitude to a graticule reference line with the REF VAR control.

h. Check—gain variation as different resolution bandwidths are selected. Variation must not exceed 0.5 dB (1/4 div).

NOTE

When checking the 30 Hz resolution bandwidth, reduce the SPAN/DIV to 0.2 kHz.

i. Return the RF Attenuator to 0 dB, IF Gain selector for a Reference Level readout of -30 dBm, SPAN/DIV to 2 kHz, RESOLUTION BANDWIDTH to 3 kHz, and REF VAR control to CAL detent.

8. Check Sensitivity: (-127 to -52 dBm, depending on resolution bandwidth and frequency band)

NOTE

Sensitivity for the 7L18 is specified according to the input or average noise level. The 7L18 calibrator is the reference used to calibrate the display. Accuracy of this reference can be verified using a 2.0 GHz bandpass filter with known loss and an accurate power meter.

a. Set the front panel controls as follows:

CENTER FREQUENCY	Within Band 1 (1.5 to 3.5 GHz)
Display Mode	10 dB/DIV
RF Attenuator	0 dB
REFERENCE LEVEL	-30 dBm
FREQ SPAN/DIV	2 kHz
RESOLUTION BANDWIDTH	3 MHz
TIME/DIV	0.5 s
PEAK/AVERAGE Cursor	Top of Screen
Digital Storage	Display A/Display B

b. Disconnect the calibrator signal from the RF Input.

c. Check—noise level below the -30 dBm reference level (see Fig. 4-6). Must not exceed -79 dBm (see Table 4-5).

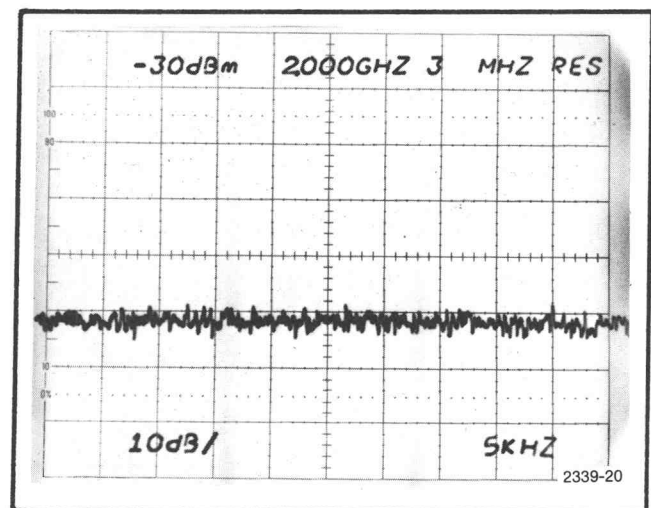

Fig. 4-6. Measuring Average Noise Level as an Indication of Sensitivity.

Table 4-5
7L18 SENSITIVITY

Frequency Range (GHz)	Average Noise Level dBm (max.) Resolution Bandwidth					
	3 MHz	0.3 MHz	30 kHz	3 kHz	300 Hz	30 Hz
1.5 to 3.5	-79	-89	-99	-109	-119	-127
2.5 to 4.5	-79	-89	-99	-109	-119	-127
3.5 to 7.5	-69	-79	-89	-99	-109	-117
6.5 to 12.5	-67	-77	-87	-97	-107	-115
9.5 to 18.0	-52	-62	-72	-82	-92	
12.5 to 18.0	-50	-60	-70	-80	-90	
18.0 to 26.5 ^a	-60	-70	-80	-90	-100	
26.5 to 40 ^a	-55	-65	-75	-85	-95	
40 to 60.5 ^a	-45	-55	-65	-75	-85	

^aHigh performance type mixers.

d. Check—noise level for 300 kHz and 30 kHz resolution bandwidths. Compare this level with the characteristics listed in Table 4-5.

e. Increase the IF Gain for a REFERENCE LEVEL of -60 dBm and reduce TIME/DIV to 10 s.

f. Check—average noise level for 3 kHz, 300 Hz, and 30 Hz resolution bandwidths. Compare these levels with characteristics listed in Table 4-5.

g. Repeat this procedure for each coaxial (internal) mixer band (1—5).

b. Switch PHASE LOCK to AUTO and then decrease the SPAN/DIV to 500 Hz keeping the signal centered on screen with the tuning controls.

c. Activate MAX HOLD. Do **NOT** disturb the instrument for one hour.

d. Check—stability or drift as the width of the response (see Fig. 4-7) over the specified time period. Drift must not exceed 2 kHz.

e. Deactivate MAX HOLD, switch PHASE LOCK to OFF, SPAN/DIV to 20 kHz, re-center the calibrator signal, then reactivate MAX HOLD.

f. Check—stability over one hour period with phase lock inoperative. Drift must not exceed 50 kHz.

NOTE

This procedure may be used to check sensitivity characteristics for optional external waveguide mixers when an accurate signal source is used to establish a reference.

9. Check Stability: (Within 2 kHz/hr x n, when phase locked; and within 50 kHz/hr x n when phase lock is inoperative)

NOTE

Stability is checked only after a 2 hour warmup period at a fixed frequency.

a. Set the Display Mode to 10 dB/DIV, SPAN/DIV to 1 MHz, RESOLUTION BANDWIDTH and TIME/DIV at AUTO. Tune the Calibrator signal to center screen, and push DEGAUSS button.

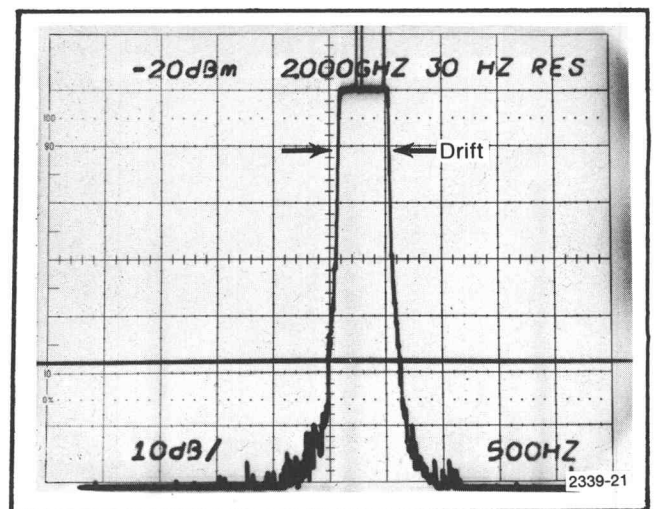

Fig. 4-7. Measuring Stability Using MAX HOLD Feature of 7L18.

10. Check Incidental FM: (≤ 10 Hz x n when phase locked; ≤ 10 kHz x n when not phase locked)

NOTE

This measurement is dependent on oscillator stability; therefore, the instrument must have at least a 2 hour warmup period. Recommend performing this check after stability has been checked.

a. Set the 7L18 controls as follows:

CENTER FREQUENCY	1.00
FREQ SPAN/DIV	100 kHz
RESOLUTION BANDWIDTH	30 kHz
TIME/DIV	AUTO
Display Mode	LIN
REFERENCE LEVEL	-30 dBm
Digital Storage	ON
PHASE LOCK	AUTO

b. With the calibrator signal tuned to center screen, decrease SPAN/DIV to 10 kHz and then position the signal with the FINE tune control, so the slope (horizontal span versus vertical excursion) or the filter response can be measured over four divisions of amplitude (see Fig. 4-8).

c. Calculate the frequency excursion per division of amplitude (e.g., if the horizontal excursion is 5 kHz over the four divisions, the slope equals 1.25 kHz/Div).

d. Switch PHASE LOCK to "OFF", decrease SPAN/DIV to 0 Hz, in steps, keeping the signal centered with the tuning control. At 0 Hz span, carefully tune so the display is near mid screen (see Fig. 4-8). Set TIME/DIV to 0.5 s.

e. Check—the peak-to-peak amplitude deviation over a 3 second (6 division) span. Deviation must not exceed 10 kHz (8 divisions at 1.25 kHz/div).

NOTE

Disregard radical excursions caused by frequency drift of the oscillator. Since FM is a multiple of "n" or the oscillator harmonic, there is no need to check bands above 4.5 GHz.

f. Switch PHASE LOCK to AUTO, SPAN/DIV to 10 kHz, TIME/DIV to AUTO, and RESOLUTION BANDWIDTH to 3 kHz.

g. Keep the calibrator signal centered with the FINE tuning control as the SPAN/DIV is reduced to 0.2 kHz and the RESOLUTION BANDWIDTH to 300 Hz.

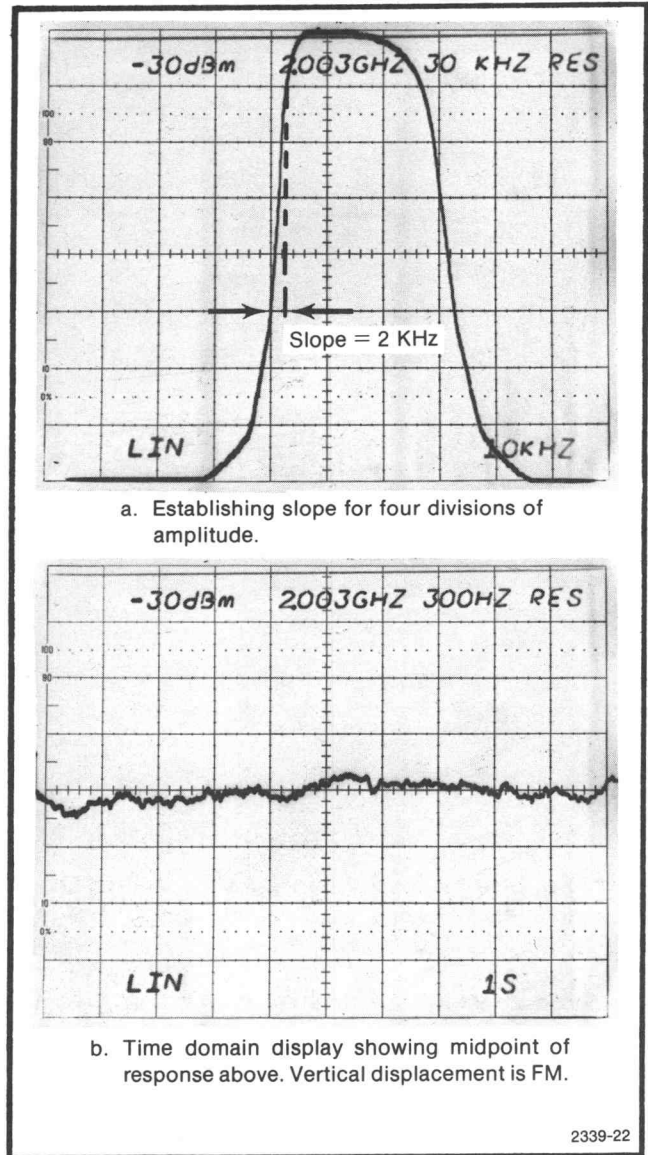

Fig. 4-8. Measuring Incidental FM.

h. Again calculate the frequency excursion per division of display (e.g., 60 Hz ÷ 4 = 15 Hz/div).

i. Decrease the FREQ SPAN/DIV to 0 Hz and carefully adjust the FINE tuning to center the response. Set TIME/DIV to 0.5 s.

j. Check—the peak-to-peak deviation over six divisions (3 seconds) of span. Must not exceed 10 Hz (3/4 of a division as per the example in part h).

11. Digital Storage

a. Set the 7L18 controls as follows:

CENTER FREQUENCY	2.000 (1.500) GHz
Display Mode	10 dB/DIV
RF Attenuator	30 dB
REFERENCE LEVEL	+0 dBm
TIME/DIV	0.2 s
FREQ SPAN/DIV	1 MHz
RESOLUTION BANDWIDTH	3 MHz
Digital Storage	Display A

b. With the calibrator signal applied to the RF Input, tune the signal to center screen and activate SAVE A.

c. Change the RF Attenuator to 40 dB and activate DISPLAY B digital storage. Display B of the Calibrator signal should be 10 dB less than display A.

d. Activate B—(SAVE A).

e. Check—B—(SAVE A) display should be the difference between display B and display A (approximately 10 dB), see Fig. 4-9.

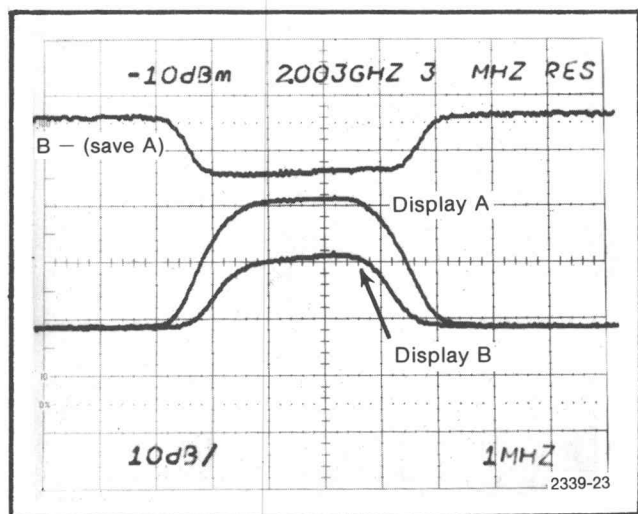

Fig. 4-9. Using Digital Storage Feature to Measure Differential Between Two Displays.

f. Deactivate SAVE A and B—(SAVE A) functions and activate MAX HOLD.

g. Change the RF Attenuator and CENTER FREQUENCY settings and then note that the MAX HOLD function retains and holds the maximum signal amplitude and frequency excursion.

h. Deactivate MAX HOLD and select DISPLAY A. Select AUTO BANDWIDTH resolution and reduce the SPAN/DIV to 100 kHz keeping the signal centered on screen with the tuning controls.

i. Vary the PEAK/AVERAGE control to shift the cursor over the screen and note that signal and noise are averaged below the cursor.

12. Check Frequency Response (Frequency Response from 1.5 GHz to 18 GHz is within ± 5 dB)

Frequency Response is the peak-to-peak variation of the displayed amplitude over a specified center frequency range, measured at the center frequency.

An exact measurement of frequency response over the 1.5 GHz to 18 GHz range would require setting each discrete frequency within the range to Center Frequency, maximizing the display with the PEAKING control, and noting the displayed amplitude. A procedure that is not exact but more expeditious and provides an indication of the instrument performance with respect to frequency response may be conducted as follows. First, perform a flatness check over the full frequency span with the PEAKING control set to the grey area. Note any segments of the display that are outside the ± 5 dB specification. Second, tune to the center of these segments, reduce the span as necessary to encompass the segment, then adjust the PEAKING control for optimum response and recheck the flatness of the segment for conformance with the specification.

NOTE

Because cable losses become significant at frequencies above 1.0 GHz, use short (25 inch or less) semi-rigid cable, with precision Type N fittings between the signal generator and the 7L18 RF Input connector. Impedance match between the source and the RF Input is important; refer to "Signal Application" under General Operating Information for more details.

a. Connect the test setup as shown in Fig. 4-10. Set the front panel controls as follows:

CENTER FREQUENCY	9.5 GHz
Band Selection	9.5—18.0
Display Mode	2 dB/DIV
REFERENCE LEVEL	-30 dBm
RF Attenuation	10 dB
TRIGGERING	FREE RUN
Digital Storage	Display A/Display B
BASE LINE CLIPPER	Fully cw
TIME/DIV	50 ms
FREQ SPAN/DIV	MAX
RESOLUTION BANDWIDTH	AUTO
PEAKING	Center of grey area

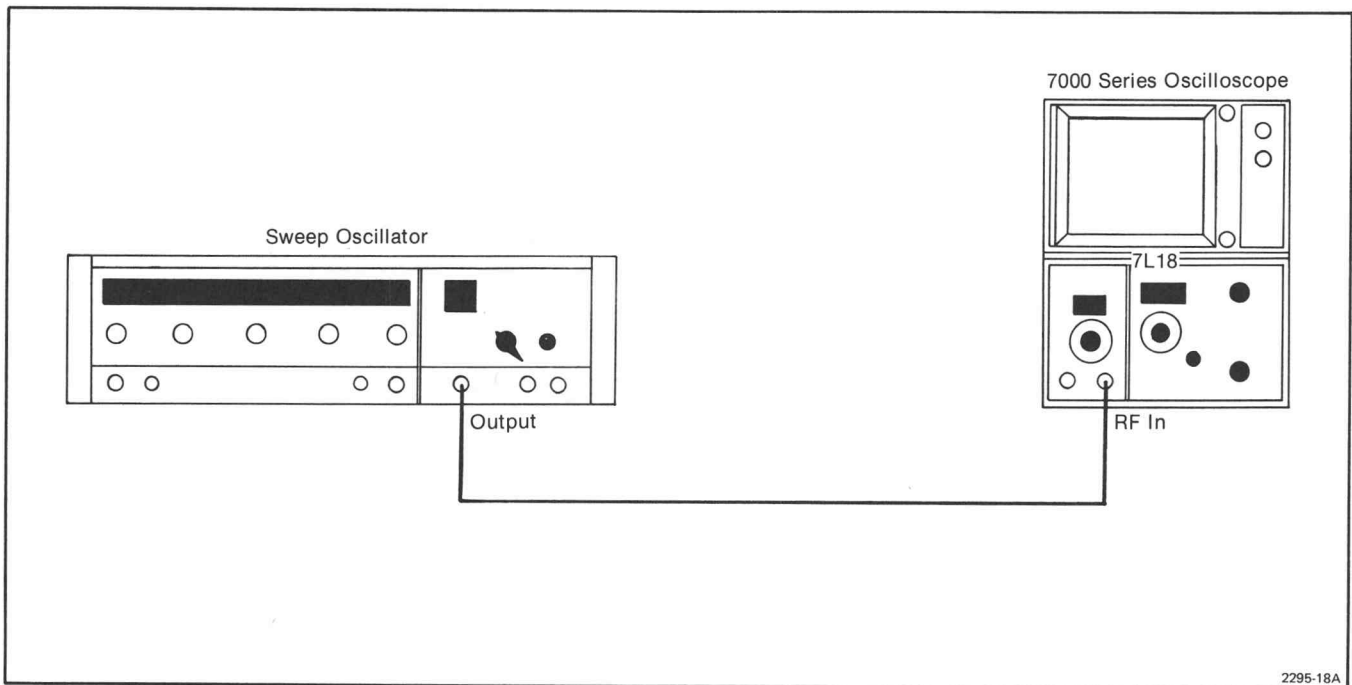

Fig. 4-10. Frequency Response Test Setup.

NOTE

Use power meter (see Calibration Output Level Check) to check flatness of the sweeper and cable before proceeding.

b. Set the frequency sweeper to sweep from 9.5 GHz to 18.0 GHz. Apply the sweeper output to the RF INput of the 7L18 and adjust the output for a mean average about a graticule line.

c. Check the flatness across the full frequency span. Note any segments where the flatness varies more than ± 5 dB with respect to the mean reference level. Total allowable deviation is 10 dB.

d. Tune to the center of an out of tolerance segment, reduce the SPAN/DIV as necessary, optimize the response with the PEAKING control, and recheck the flatness of the segment.

e. Change Band Selection to 6.5—12.5 GHz. Change the Sweeper controls to produce the appropriate frequencies, and repeat parts c and d.

f. Repeat this procedure for each Band Selection.

13. Check Intermodulation Distortion (Third-order products are down 70 dB or more from any two -40 dBm signals for 1.5 to 1.8 GHz, and 70 dB or more from any -30 dBm signals for 1.8 to 18 GHz, referenced to the input mixer, when the IF gain is not in the gain-reduced, red, position.)

a. Connect the test setup as shown in Fig. 4-11. Set the front panel controls as follows:

CENTER FREQUENCY	2.0 GHz
Display Mode	LOG 10 dB/DIV
REFERENCE LEVEL	-30 dBm
RF Attenuation	10 dB
TRIGGERING	FREE RUN
Digital Storage	DisplayA/Display B
Band Selection	1.5—3.5
BASE LINE CLIPPER	Fully cw
TIME/DIV	AUTO
FREQ SPAN/DIV	1 MHz
RESOLUTION BANDWIDTH	30 kHz

b. Apply a 2.001 GHz, -10 dBm signal from No. 1 signal generator through a 20 dB attenuator and the "T" connector to the RF INput. The displayed signal should appear about one division to the right of center screen.

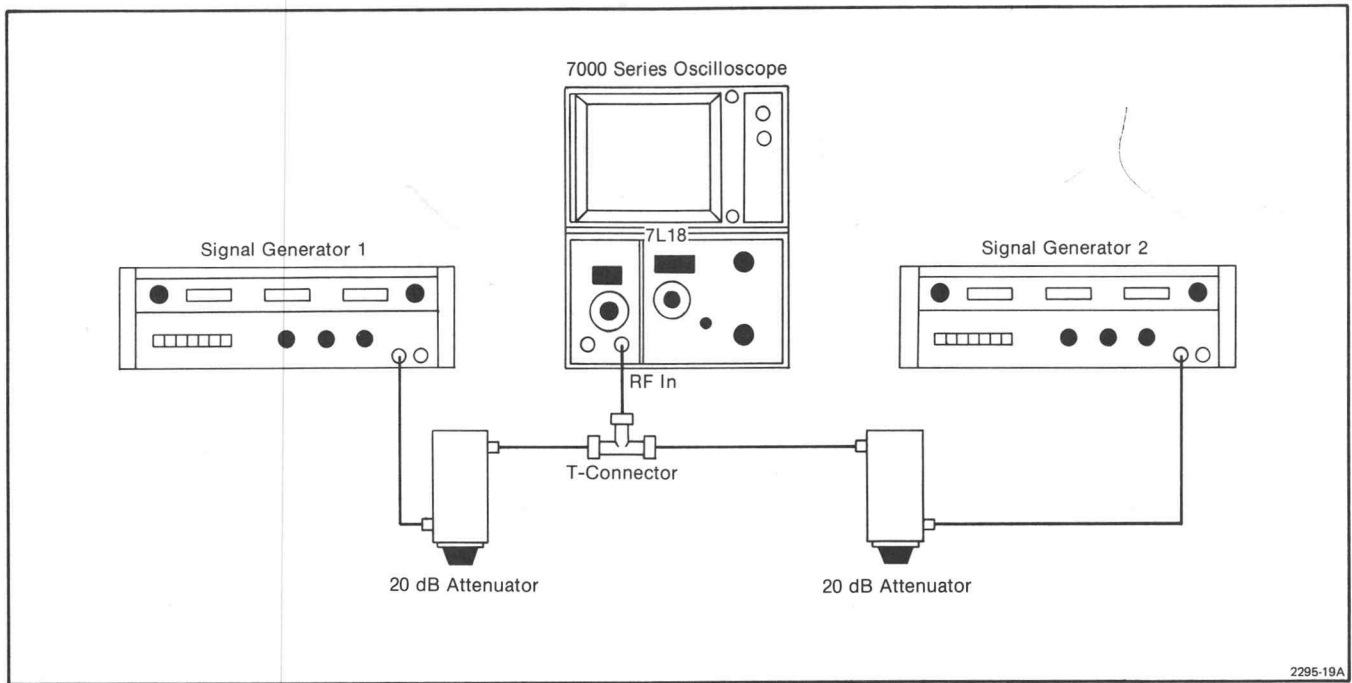

Fig. 4-11. Intermodulation Distortion Check Test Setup.

c. Apply a 2.000 GHz, -10 dBm signal from No. 2 signal generator through a 20 dB attenuator and the "T" connector to the RF INPUT. The displayed signal should appear at center screen over the center frequency line. Adjust the output level of the signal generators so that both signals are full screen (eight divisions).

d. Reduce the RESOLUTION BANDWIDTH to 300 Hz.

e. Check that the third order intermodulation product (about three divisions from center screen) are at least 7.0 divisions (-70 dB) below the full-screen signals (see Fig. 4-12).

f. Increase RF Attenuation to 20 dB.

g. Decrease the signal generator frequencies to check IM below 1.8 GHz. IM products must be down 70 dB or more below the reference signals.

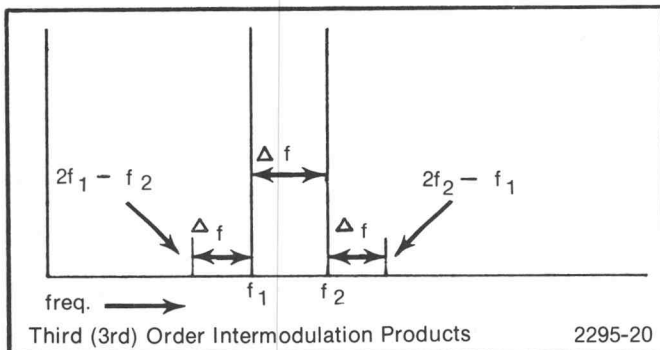

Fig. 4-12. Intermodulation Products (Distortion).

h. Increase the input frequencies to check IM distortion above 2.0 GHz using the preceding procedures. IM products must be down 70 dB or more below the reference signals.

i. Disconnect the test equipment to the 7L18.

14. Check Triggering Operation and Sensitivity (Internal trigger sensitivity ≥ 1 division, external trigger sensitivity +0.5 V to 50 V peak, 15 Hz—1 MHz.)

a. Connect the test setup as shown in Fig. 4-13. Set the 7L18 front panel controls as follows:

CENTER FREQUENCY	2.0 GHz
Display Mode	LIN
REFERENCE LEVEL	-30 dBm
RF Attenuation	0 dB
TRIGGERING	INT/EXT
Digital Storage	Display A/Display B
Band Selection	1.5—3.5
BASE LINE CLIPPER	Fully cw
TIME/DIV	20 ms
FREQ SPAN/DIV	500 MHz
RESOLUTION BANDWIDTH	3 MHz

b. Apply a 2.0 GHz signal from the UHF signal generator to the RF INPUT of the 7L18 and tune the CENTER FREQUENCY to the signal.

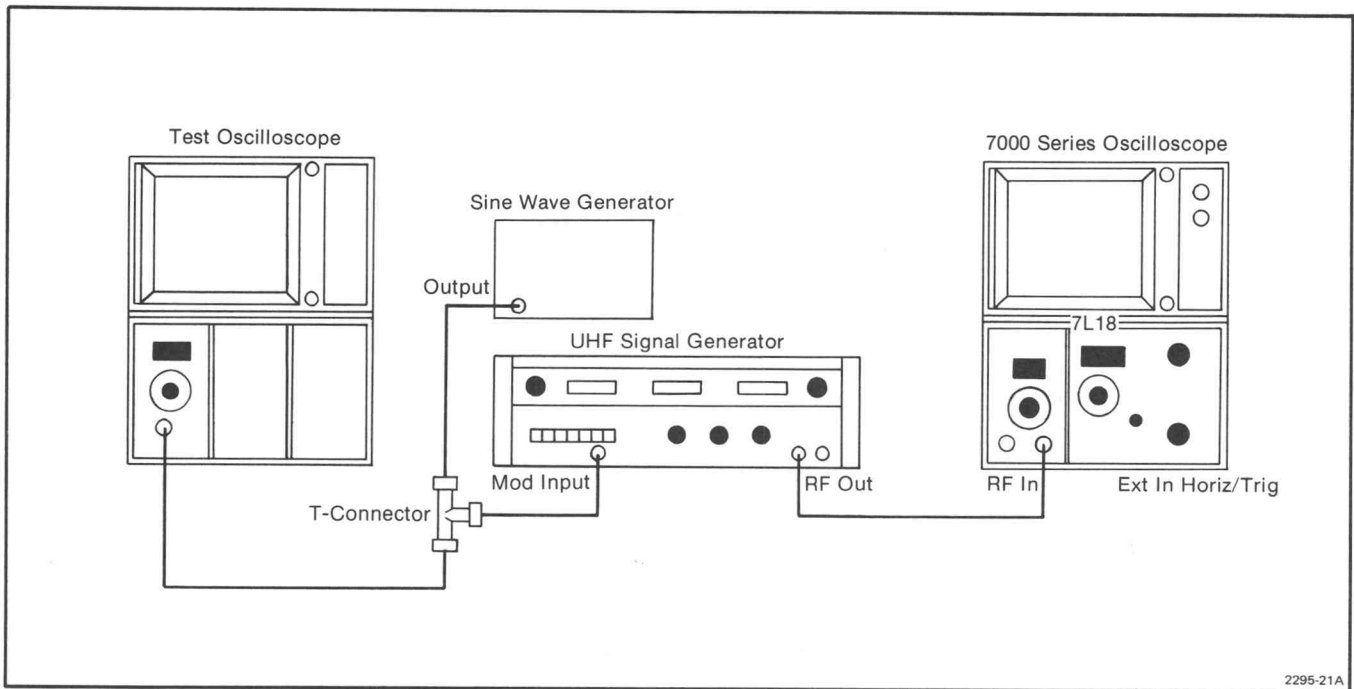

Fig. 4-13. Triggering Operation and Sensitivity Test Setup.

c. Apply the output of a sine-wave signal generator to the modulation input of the UHF generator. Reduce the RESOLUTION BANDWIDTH to 300 kHz, then decrease the FREQ SPAN/DIV to 0, keeping the CENTER FREQUENCY tuned to the UHF signal. Tune to the side of the signal with the FINE tuning adjustment so the display amplitude is about half screen.

d. Modulate the UHF signal with 15 Hz, adjusting the sine-wave generator output until the display amplitude of the 15 Hz modulation equals one division.

e. Check internal trigger operation by tuning through the 15 Hz to 1 MHz frequency range and noting that the display remains synchronized over the frequency range of the trigger input.

NOTE

At the upper limit (1 MHz) it may be necessary to detune the center frequency to obtain a modulation envelope of one division.

f. Remove the cables connecting the sine-wave generator to the UHF generator and the UHF generator to the 7L18. Return the RESOLUTION BANDWIDTH to 3 MHz.

g. Apply a 1 kHz signal from the sine-wave generator through a BNC to pin-jack cable to the EXT IN HORIZ/TRIG jacks on the 7L18. Using the test oscilloscope to monitor the generator output, set the sine-wave generator output level for 1.0 V peak-to-peak. Activate the SGL SWP function.

h. Check external triggering by depressing the SGL SWP pushbutton and checking for a single sweep each time the sweep button is depressed. As the applied trigger signal frequency is increased from 15 Hz to 1 MHz, ensure that the input level remains at 0.5 V peak.

i. At some frequency within the 15 Hz to 1 MHz range, increase the input level to 50 V peak and note that the display remains triggered.

j. Disconnect the test equipment to the 7L18.

15. Check External Horizontal Input Voltage Requirement (0 V to 10 V \pm 1 V should sweep the analyzer the full frequency span)

a. Connect the test setup as shown in Fig. 4-14. Set the 7L18 TIME/DIV to EXT IN, TRIGGERING to FREE RUN, FREQ SPAN/DIV to 500 MHz, and RESOLUTION BANDWIDTH to 300 kHz.

b. With the EXT IN HORIZ/TRIG pin-jack grounded, position the crt beam of the 7L18 oscilloscope to the left graticule edge to establish a zero voltage reference.

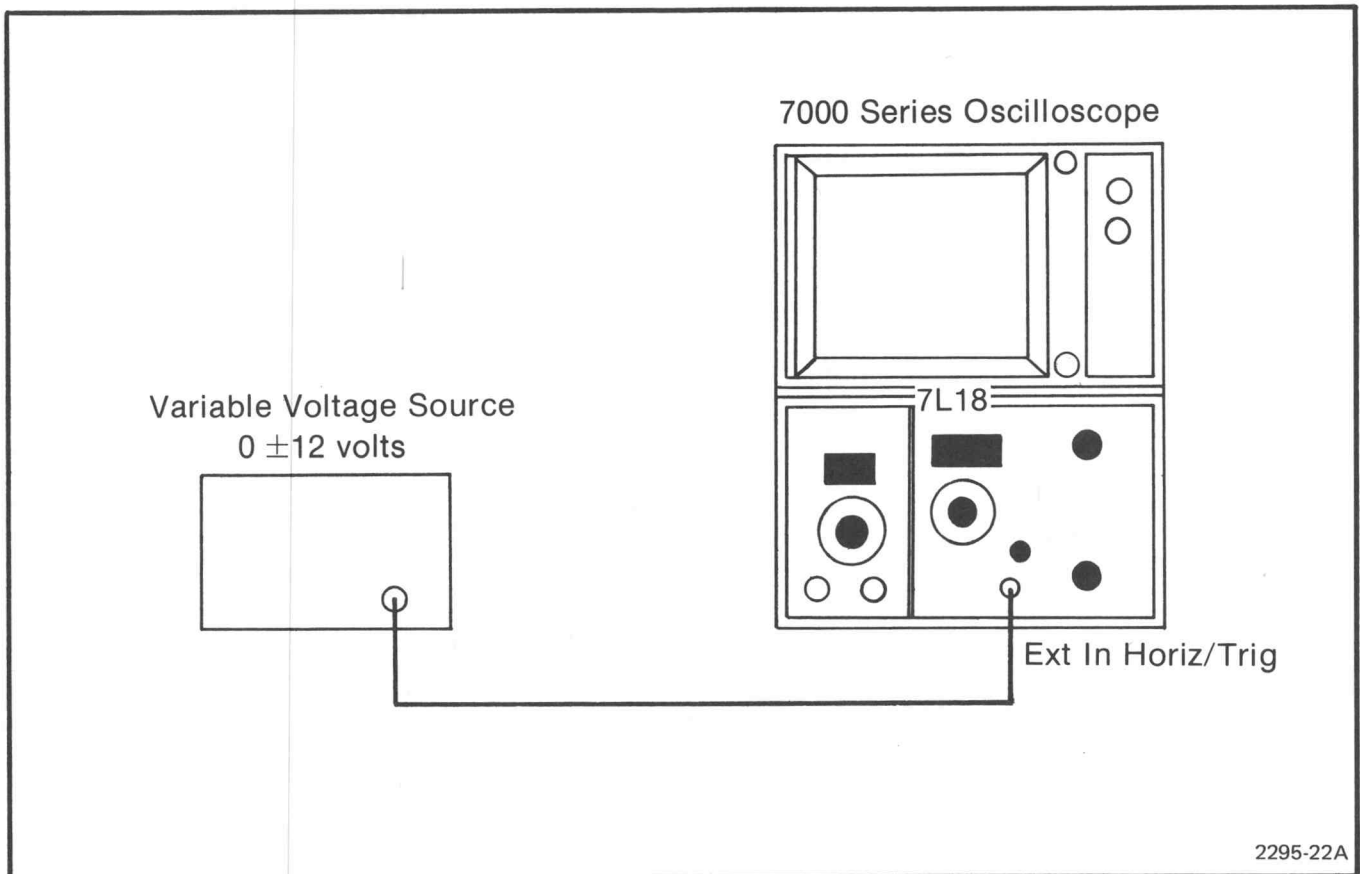

2295-22A

Fig. 4-14. External Horizontal Input Voltage Test Setup.

c. Apply a variable voltage source, such as the variable power supply, to the EXT IN HORIZ/TRIG pin-jacks and adjust the voltage output so the beam is deflected the full 10-division span.

d. Check—the voltage source should equal $+10\text{ V} \pm 1\text{ V}$.

NOTE

An alternate method using a sine wave to check external sweep operation is as follows:

1. After the crt beam has been positioned to the zero voltage reference as described in part b, apply a 1 kHz sine wave with an amplitude of 10 V peak (20 V p-p, referenced at 0 V) to the EXT IN HORIZ/TRIG connector.

2. The crt beam should sweep the full 10 divisions (+0.1 division) of the graticule when the input voltage is 10 V peak $\pm 1\text{ V}$.

e. Disconnect the voltage or signal source to the EXT IN HORIZ/TRIG connector and return the TIME/DIV selector to AUTO.

16. Check Video Output Level ($500\text{ mV} \pm 5\%$ of video signal per division of display above the baseline)

a. Connect the test setup as shown in Fig. 4-15. Apply the VIDEO OUT signal of the 7L18 to the input of a dc-coupled test oscilloscope with sensitivity set to 1 V/div. Set the 7L18 Display Mode to LOG 2 dB/DIV, REFERENCE LEVEL to -20 dBm , TIME/DIV to AUTO, FREQ SPAN/DIV to 100 kHz, and RESOLUTION BANDWIDTH to 300 kHz.

b. Position the base of the CAL OUT signal on the bottom graticule line of the 7L18 display using the VERTICAL POSITION control and adjust the REF VARIABLE control for eight divisions of signal amplitude.

c. Check the amplitude of the video output signal using the test oscilloscope. Note the dc zero volt level. Video amplitude should equal 4.0 volts $\pm 0.2\text{ volt}$ as measured from the zero voltage reference level. See Fig. 4-16.

d. Disconnect the test equipment to the 7L18.

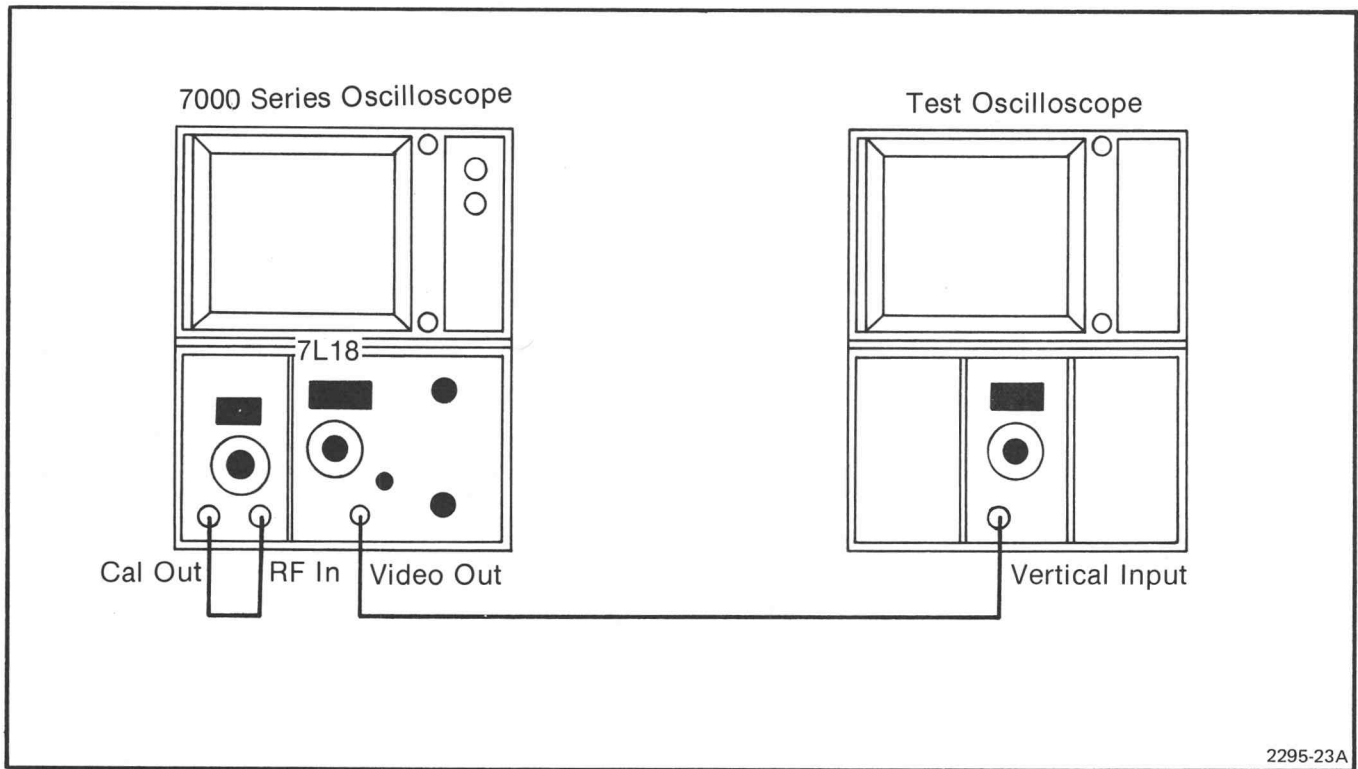

Fig. 4-15. Video Output Level Test Setup.

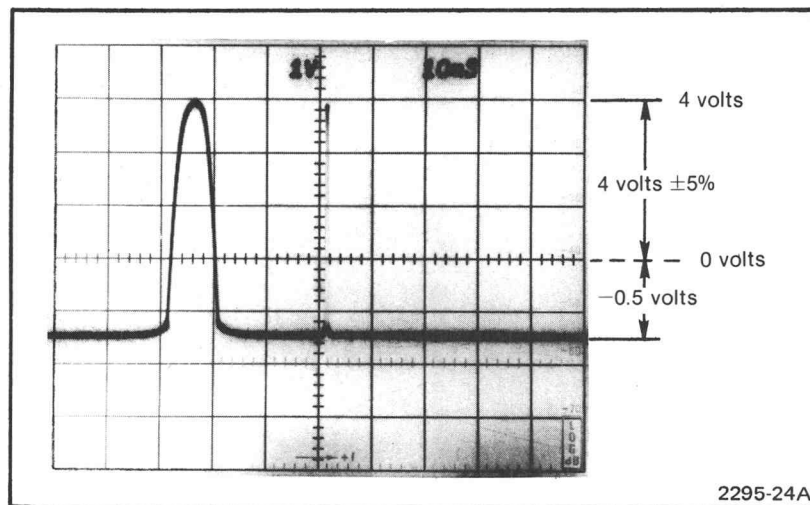

Fig. 4-16. Video Output Test Waveshape.

17. Check Frequency Span Accuracy and Linearity (Accuracy within 5% of span selected; linearity within 5% over the center eight divisions)

Span Accuracy is the displacement error of calibrator markers from the center screen reference over ± 10 divisions of span. Linearity is the displacement error between successive markers with respect to the SPAN/DIV setting.

a. Connect the test setup as shown in Fig. 4-17. Set the 7L18 front-panel controls as follows:

CENTER FREQUENCY	2.0 GHz
Display Mode	LOG 10 dB/DIV
REFERENCE LEVEL	-30 dBm
RF Attenuation	0 dB
TRIGGERING	FREE RUN
Digital Storage	Display A/Display B
Band Selection	1.5—3.5
BASE LINE CLIPPER	Fully cw
TIME/DIV	AUTO
FREQ SPAN/DIV	200 MHz
RESOLUTION BANDWIDTH	AUTO

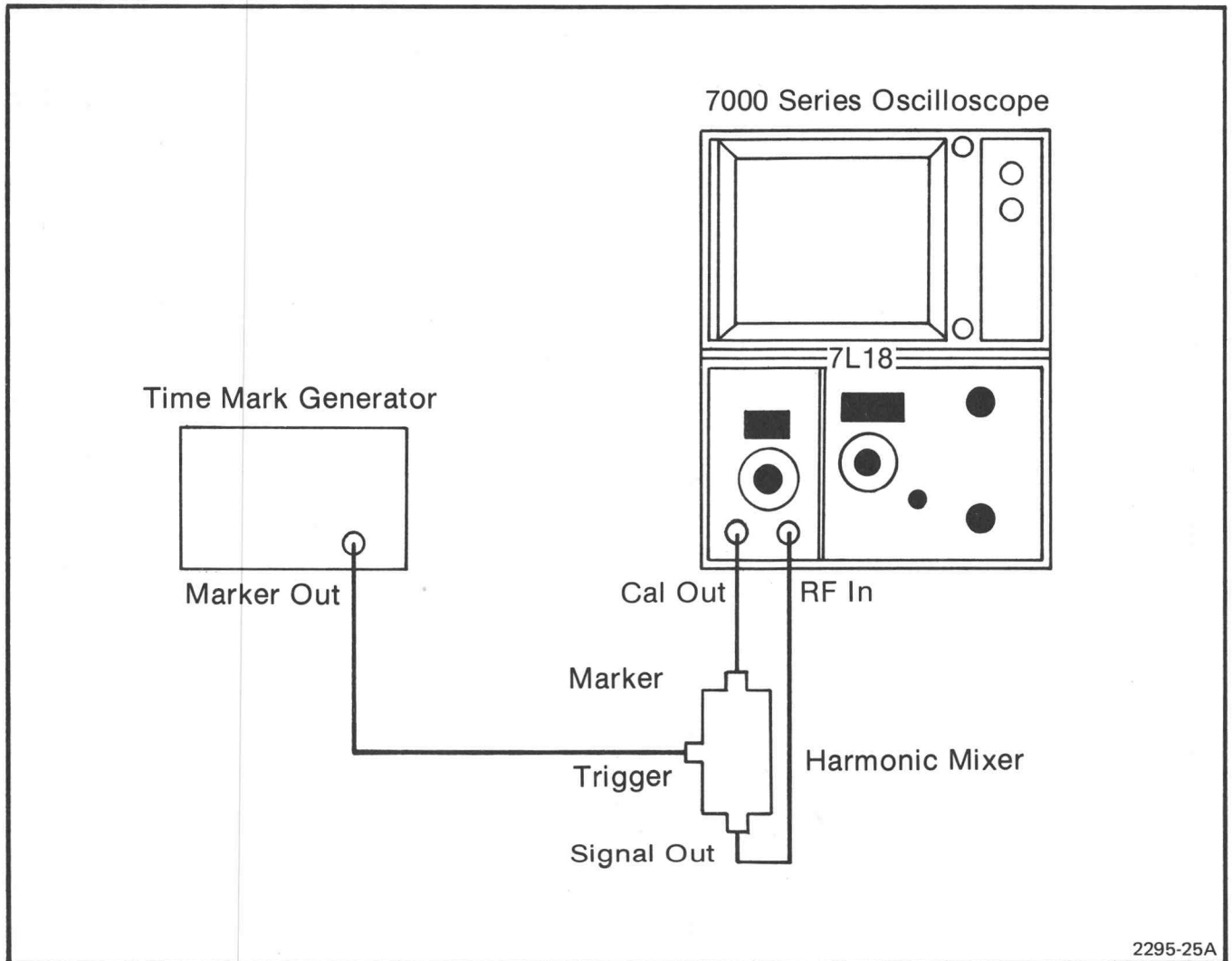

Fig. 4-17. Freq. Span/Div Test Setup.

Table 4-6

FREQUENCY SPAN/DIVISION MARKERS/DIVISION

Freq Span/Div	Resolution	Time Mark Generator	
		Marker Out	Markers/Div
500 MHz	3 MHz	0	1 per div ^a
200 MHz	3 MHz	10	2 per div ^b
100 MHz	3 MHz	10 ns	1 per div
50 MHz	300 kHz	20 ns	1 per div
20 MHz	300 kHz	50 ns	1 per div
10 MHz	300 kHz	100 ns	1 per div
5 MHz	300 kHz	200 ns	1 per div
2 MHz	30 kHz	500 ns	1 per div
1 MHz	30 kHz	1 μ s	1 per div
500 kHz	3 kHz	2 μ s	1 per div
200 kHz	3 kHz	5 μ s	1 per div
100 kHz	3 kHz	10 μ s	1 per div
50 kHz	3 kHz	20 μ s	1 per div
20 kHz	300 Hz	50 μ s	1 per div
10 kHz	300 Hz	100 μ s	1 per div
5 kHz	300 Hz	200 μ s	1 per div
2 kHz	30 Hz	500 μ s	1 per div
1 kHz	30 Hz	1 ms	1 per div
500 Hz	30 Hz	2 ms	1 per div
200 Hz	30 Hz	5 ms	1 per div

^a500 MHz calibration markers available between graticule lines 4 through 8 because of analyzer frequency range.

^b100 MHz markers available between graticule lines 2 through 7 because of analyzer frequency range.

b. Apply 10 ns markers through the Harmonic Mixer to the RF INput. Verify span/division and linearity accuracy by noting two (100 MHz) markers per division, $\pm 5\%$.

c. Change the FREQ SPAN/DIV to 100 MHz. Verify accuracy by noting one (100 MHz) marker per division, $\pm 5\%$.

d. Apply markers and set the FREQ SPAN/DIV control as directed in Table 4-6. Verify frequency span and linearity accuracy by noting the markers per division and dispersment across the full span for each setting. Adjust the RESOLUTION BANDWIDTH as required to optimize marker resolution.

18. Check Sweep Rate (TIME/DIV) Accuracy (Accuracy within 5% of the sweep rate selected)

a. Connect the test setup as shown in Fig. 4-18. Set the front panel controls as per test 10.

b. Apply a 2.0 GHz, -30 dBm signal from the UHF signal generator to the RF Input of the 7L18 and tune the CENTER FREQUENCY to the signal. Modulate the UHF carrier with time markers by connecting the Marker Out of the Time-Mark Generator to the External AM Inputs of the UHF signal generator.

c. With the CENTER FREQUENCY tuned to the 2.0 GHz signal from the UHF signal generator, reduce the FREQ

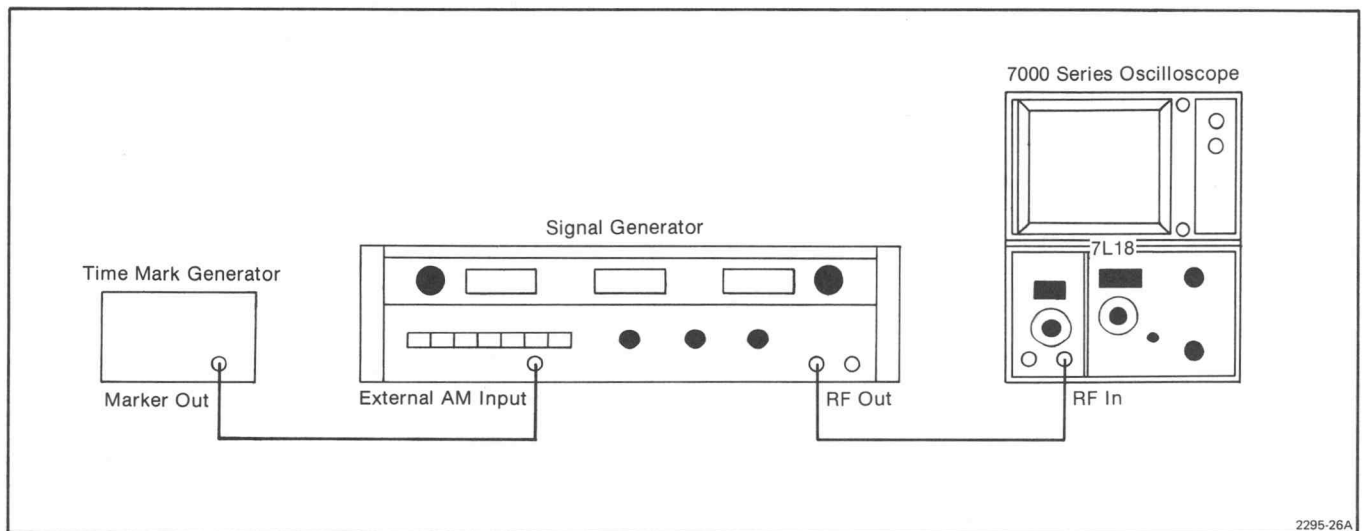

Fig. 4-18. Sweep Rate Test Setup.

SPAN/DIV to 0 for a time-domain display. If the markers are not clearly visible, it may be necessary to detune the center frequency with the FINE control.

d. Set the TIME/DIV to 0.1 ms. Adjust the UHF signal generator for a display amplitude of approximately two divisions. If the 7L18 is tuned to 2.0 GHz, a -30 dBm signal may be off screen at a setting of 0 SPAN/DIV. Reposition on the screen by using the VERTICAL POSITION control. Detune center frequency slightly with the FINE tune control.

e. Check the accuracy of the TIME/DIV selections by applying appropriate markers from the Time-Mark Generator for the TIME/DIV selection and noting the displacement between the time markers and their respective graticule divisions over the center eight divisions. The error displacement must be within 5% of the TIME/DIV selected.

NOTE

Use the HORIZ POSITION control to position a marker on the first graticule line, then note the displacement error between each marker and its respective graticule line.

f. Disconnect the test equipment to the 7L18.

19. Check the Preselector's Ultimate Rejection (at least 70 dB less on adjacent Band)

a. Connect the CAL OUT to the RF Input.

b. Set the front-panel controls as follows:

CENTER FREQUENCY	2.0 GHz
Display Mode	LOG 10 dB/DIV
Reference Level	-30 dBm
RF Attenuation	0 dB
TRIGGERING	FREE RUN
Digital Storage	Display A/Display B
Band Selection	1.5—3.5
BASE LINE CLIPPER	Fully cw
TIME/DIV	AUTO
FREQ SPAN/DIV	100 kHz
RESOLUTION BANDWIDTH	30 kHz

c. Adjust PEAKING for maximum signal amplitude.

d. Change Band selection to 2.5—4.5.

e. Any signal appearing on screen must be at least 70 dB less than the amplitude of the CAL OUT signal as it appeared on Band 1.5—3.5.

f. If this condition is not met, replace the Preselector.

PART 2—ADJUSTMENT PROCEDURES

When the 7L18 is not within the tolerance for a particular specification, determine the cause, repair as necessary, then use the appropriate adjustment procedure to return the instrument to its specification. After performing any adjustment, repeat the Performance Check to verify instrument conformance with specifications.

Allow instrument operation for at least 30 minutes in ambient air of +20°C to +30°C before performing an adjustment.

Waveform illustrations used in these instructions are often idealized. They are not intended to be representative of specification tolerances.

The numerical listing of the adjustment procedures is not an order of performance. Each procedure is independent.

Adjustments that are known to interact are noted and reference is made to the affected circuit.

Table 4-7

List of Adjustment Steps	Page
1. Adjust Sweep Amplitude and Timing	4-31
2. Adjust or Calibrate the Drive to 1st Local Oscillator FM Coil	4-33
3. Adjust 1st Local Oscillator Tuning Coil Drive Voltage and Calibrate the DVM readout	4-34
4. Calibration of the Log Amplifier	4-38
5. Calibration of the Phase Lock Control	4-40
6. Presetting the Variable Resolution Gain Adjustments	4-42
7. Calibration of the 510 MHz IF and Local Oscillators	4-44
8. Calibration of the 500 MHz Local Oscillator	4-45
9. Calibration of Digital Storage	4-50
10. Setting the constant "K" for the Zero Reference of the B-Save A Display	4-50
11. Calibration of the Resolution Bandwidth and Shape Factor	4-53
12. Input Compression Check (≥ -22 dBm, 1.5—1.8 GHz; ≥ -18 dBm, 1.8—18 GHz)	4-54
13. Adjustment of the Preselector Offset	4-54
14. Adjustment of Preselector Tracking and Flatness	4-55
15. Calibrate the Gain for Coaxial Bands 1 through 5	4-60
16. Calibrate the Gain for Waveguide Bands 6 through 10	4-60

Instrument Construction

The 7L18 is constructed to provide easy access to all adjustments while the instrument is operational, and to provide access to most components when repairs are necessary. In these procedures, the two major sections are referred to as Left and Right (see Fig. 4-19); the Right

section contains several interlocking Module Assemblies that have circuit adjustments and test points. All of these modules can be operated on extenders. Operation of the 7L18 outside the oscilloscope mainframe is through the use of three flexible plug-in extenders (see Fig. 4-19). Table 4-8 lists the items required to access all the adjustments and test points while the 7L18 is operational.

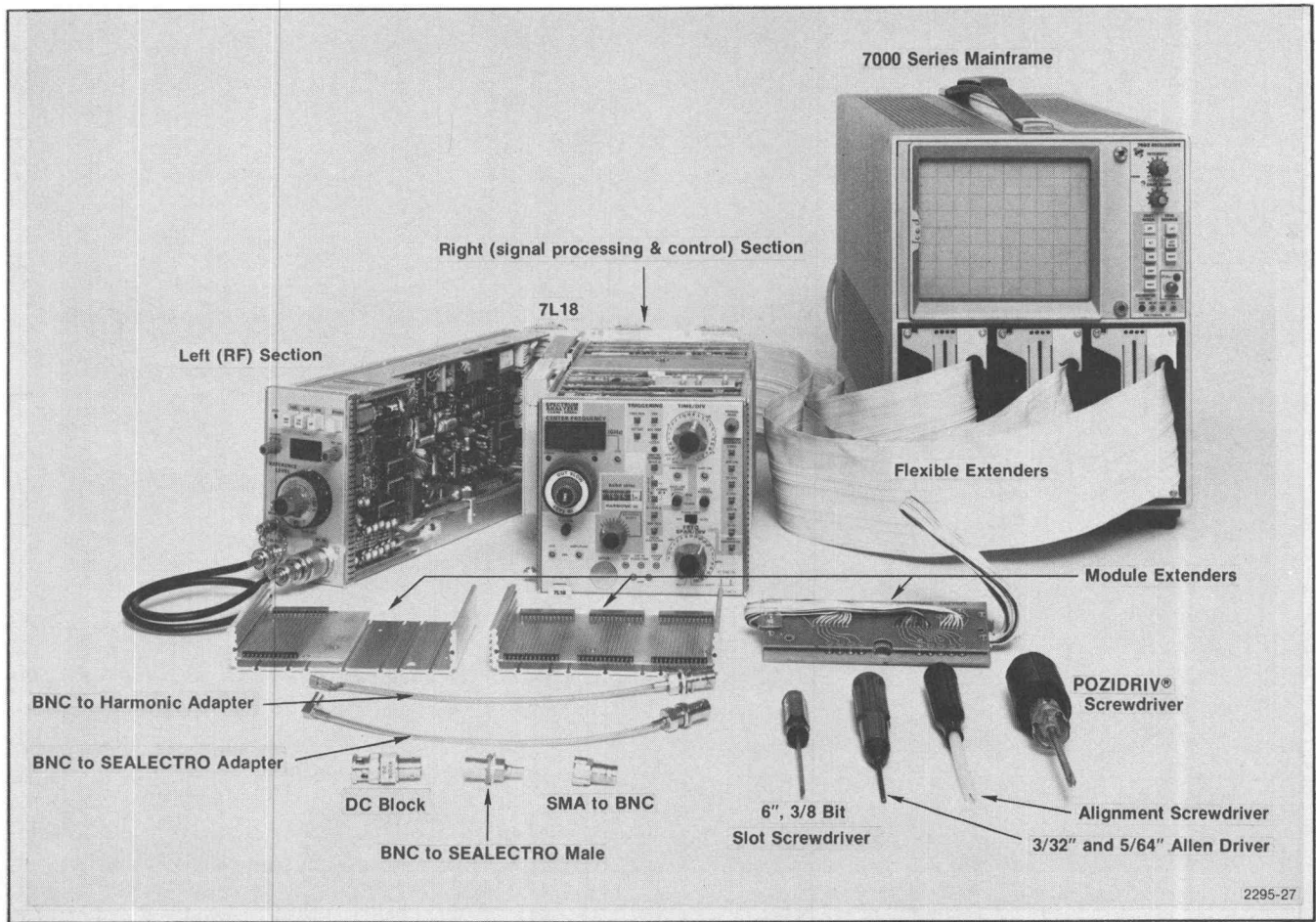

Fig. 4-19. 7L18 and 7000-Series Oscilloscope with Accessories and Tools Used When Making Calibration Adjustments.

Table 4-8

FLEXIBLE PLUG-IN EXTENDERS AND MODULE ASSEMBLY EXTENDERS

Item	Part Number	Remarks
Flexible Plug-in Extender	067-0616-00	Requires three each.
7L18 Module Extender Service Kit	006-2487-00	This Kit contains the extender types and an extractor tool.
Phase Lock Module Extender	067-0868-00	
Standard Module Extender	067-0869-00	
Narrow Module Extender	067-0870-00	
Module Extractor	003-0863-00	

Adjustment or Component Access

To access adjustments, test points, or components located on the inner sides of the Left and Right sections, separate the two sections as follows:

a. With the 7L18 outside the oscilloscope mainframe and power to the instrument turned off, remove the perforated side panel of the Left section by taking out four

Phillips-head screws. Two of these are located near the bottom edge of the side panel and two extend through the rear of the instrument into the side panel (see Fig. 4-20).

b. Remove the two screws that extend through the Left section into tabs on the Right section. These screws are located, top and bottom, near the front of the Left section and they are identified on the instrument by notes that describe their use (see Figs. 4-20 and 4-21).

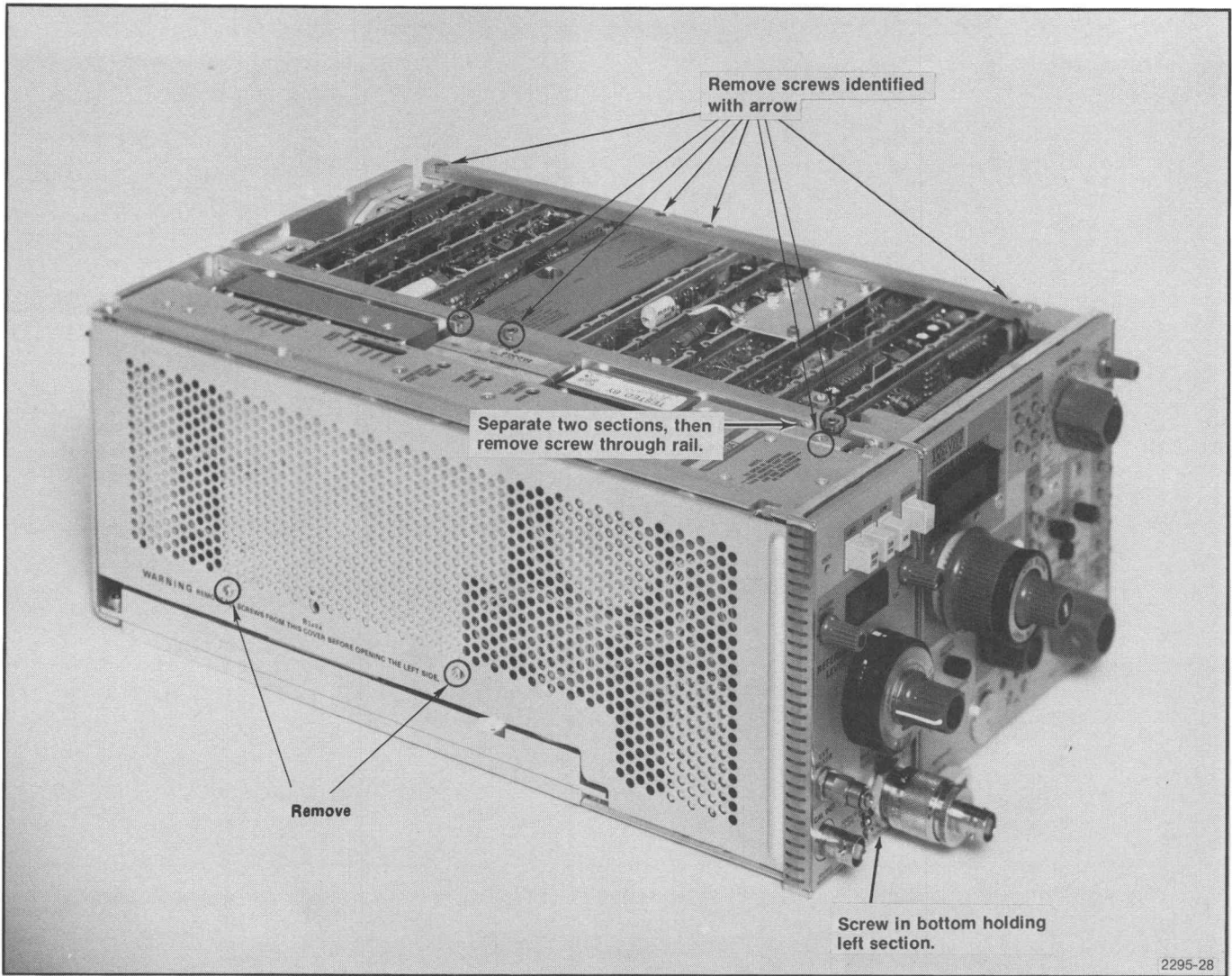

Fig. 4-20. Location of Side Panel and Retaining Rail Screws That Must be Removed to Gain Access to Calibration Adjustments.

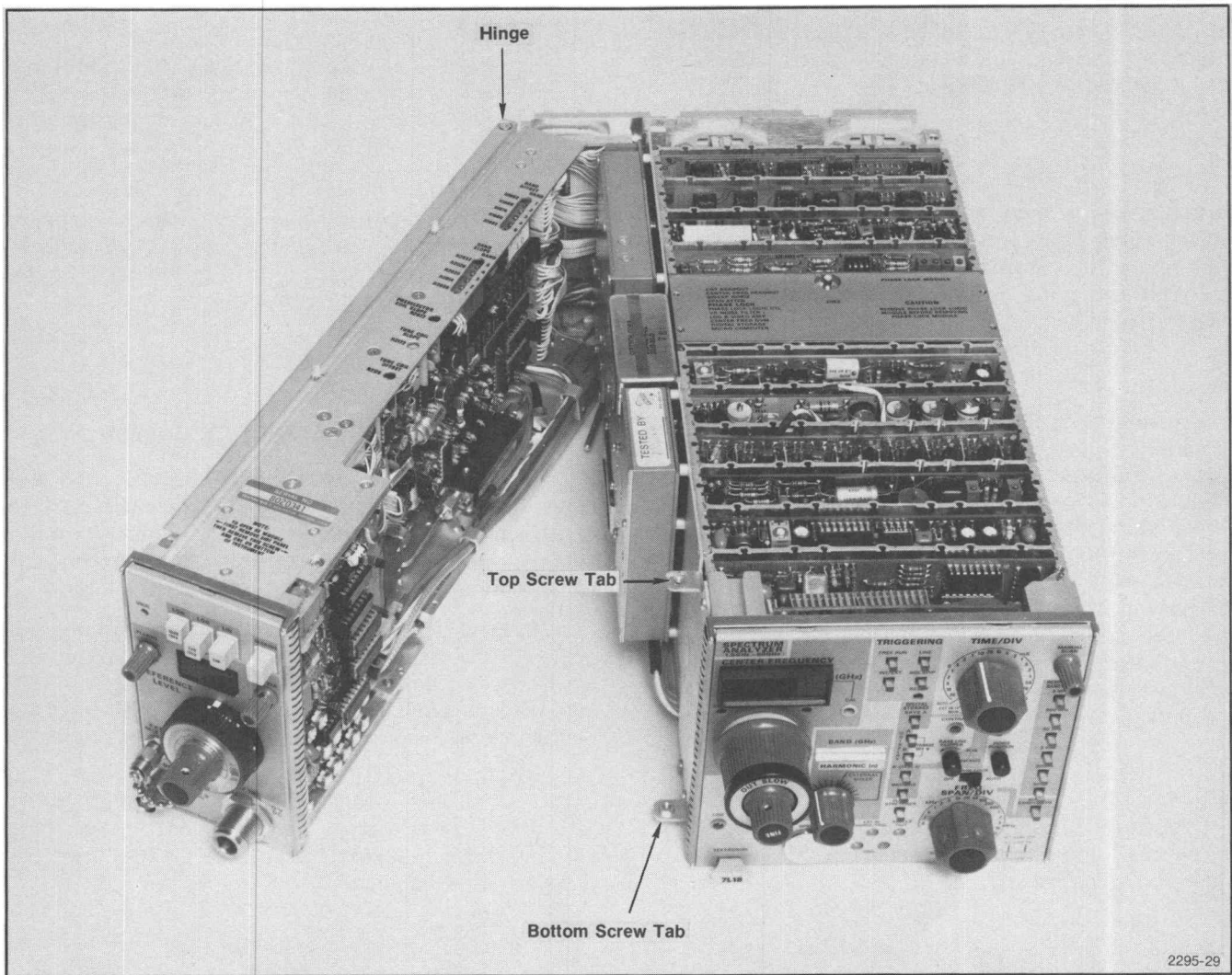

Fig. 4-21. 7L18 Showing How Two Sections are Hinged Together and Separated for Servicing.

Calibration—7L18 Service

c. The two sections can now be moved apart to expose the inner sides. The sections are mechanically and electrically connected by a hinge and cables at the rear of the instrument (see Fig. 4-21).

d. To separate a Module Assembly from the Right section, begin by removing the two retaining rails that are located along the top outside edges of the assemblies. Each rail is secured with four screws. Access to one of these screws requires that the Left section be moved apart from the Right section (see Fig. 4-20).

e. Invert the 7L18 and for any module, except Digital Storage, remove the four screws (see Fig. 4-22) that extend through the bottom of the instrument into the module being separated from the Right section. The Digital Storage Module is also fastened with four screws through the bottom of the instrument, but one is captive (see Fig. 4-22) between the outside-bottom rail and the instrument chassis. To remove this module, first remove the three non-captive screws, then unscrew the captive screw. The screw will remain in place, but the unscrewing action will force the module away from the bottom of the instrument.

f. Set the 7L18 upright and use the extractor tool to pull the selected module out of its seated position to service or plug it on an extender.

NOTE

The Phase Lock module may be pulled from the Right section by partially inserting two rail-holding screws to use as anchor pins for lifting the module.

g. A Module Assembly may be operated outside its normal position by using the appropriate Module Extender and connecting the 7L18 to the oscilloscope mainframe via Flexible Plug-in Extenders.

Access to the MICROCOMPUTER Components

The front panel of the Right section is hinged and connected to the main chassis via flexible cables. This construction provides the means to gain access to the Microcomputer components and the back side of the front panel. To open the front panel, proceed as follows:

a. With the 7L18 out of the oscilloscope mainframe and power to the instrument turned off, move the Left and Right sections apart to provide access to two Pozidriv® screws located at the top and bottom near the front of the instrument (see Fig. 4-23). Remove these two screws.

b. Invert the instrument and disconnect the retaining spring (see Fig. 4-22) to the front panel LATCH. The front panel can now be opened.

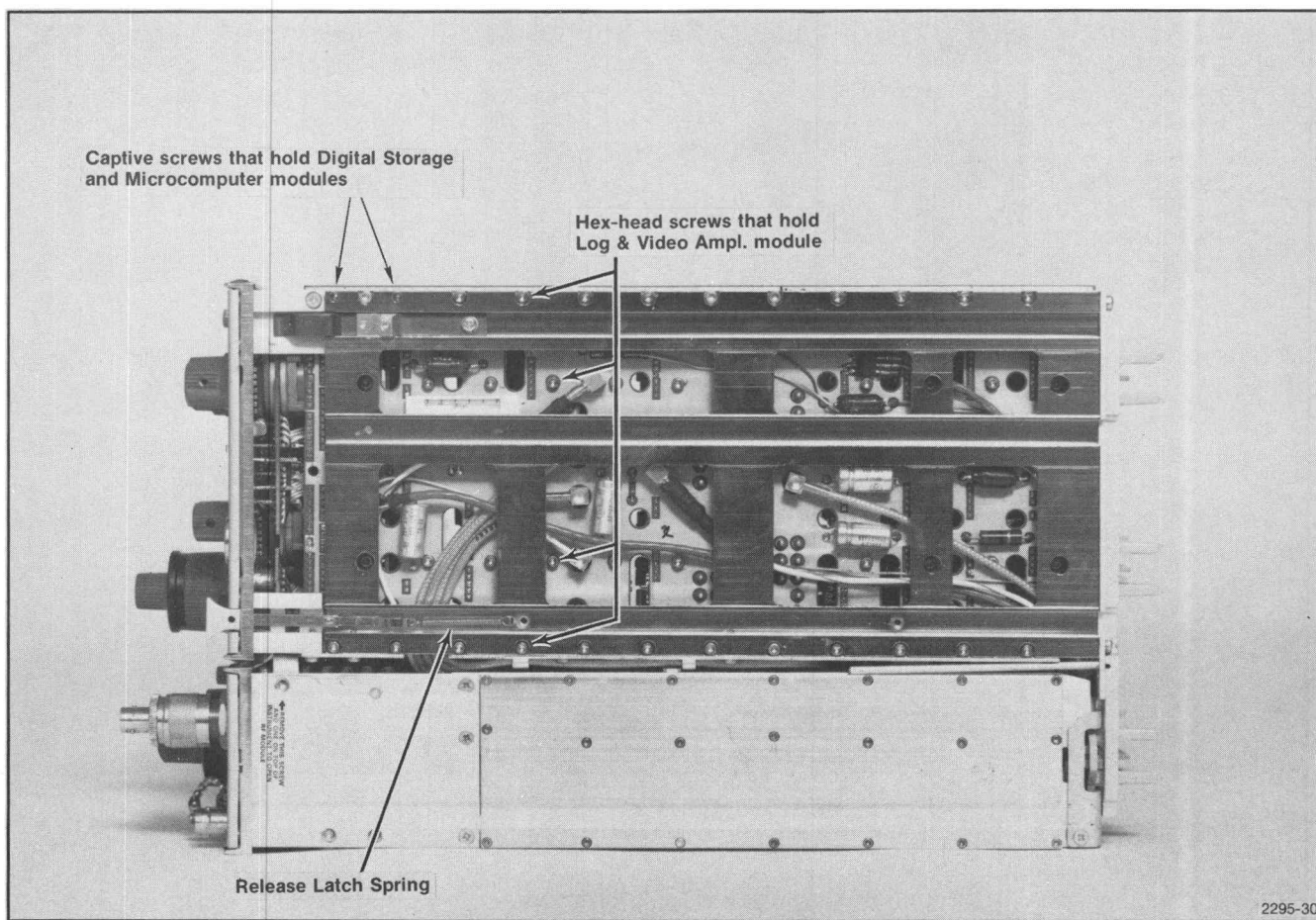

Fig. 4-22. Location of the Hexagonal Head Screws That Hold the Plug-in Module Assemblies.

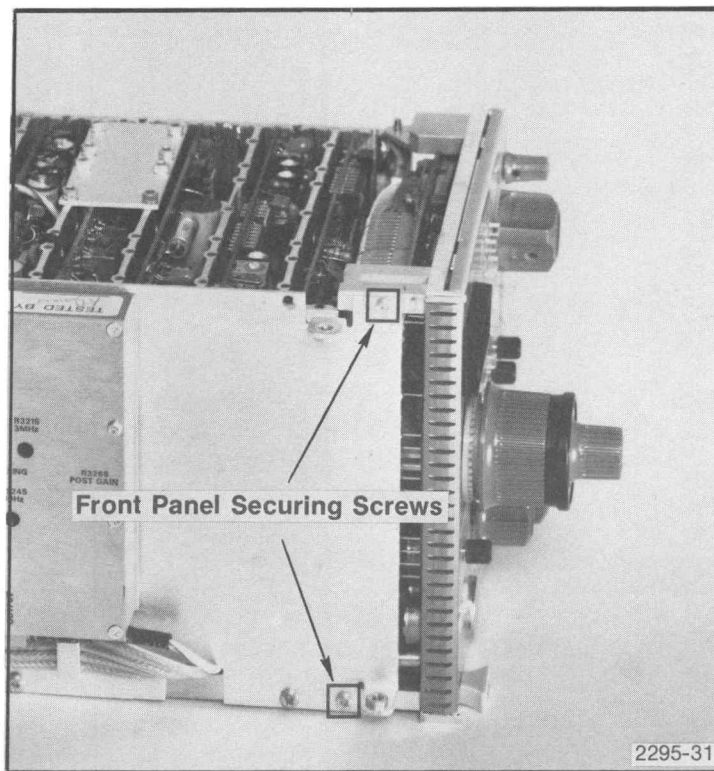

Fig. 4-23. Location of Front Panel Securing Screws.

ADJUSTMENT PROCEDURE

1. Adjust Sweep Amplitude and Timing

a. Set the following controls to the positions indicated.

7L18

FREQ SPAN/DIV	5 MHz
TIME/DIV	1 ms

Test Oscilloscope

TIME/DIV	0.1 ms
VOLTS/DIV	5 V
Input Coupling	dc

b. Remove the Span Attenuator module and use an extender to make the test points and adjustments accessible.

c. Connect the test oscilloscope probe to Zero Center Sweep, TP1340 (see Fig. 4-24). Set test oscilloscope Time/Div control to 10 ms.

d. Adjust Sweep Gain, R1308, and Sweep Centering, R1312 (see Fig. 4-30) for a 22 volt ramp centered at 0 volt.

e. Set the FREQ SPAN/DIV to 0 and connect the test oscilloscope probe to TP1370 (see Fig. 4-24).

f. Adjust the Sweep Offset, R1342, for 0 V at TP1370.

g. Remove the test oscilloscope probe.

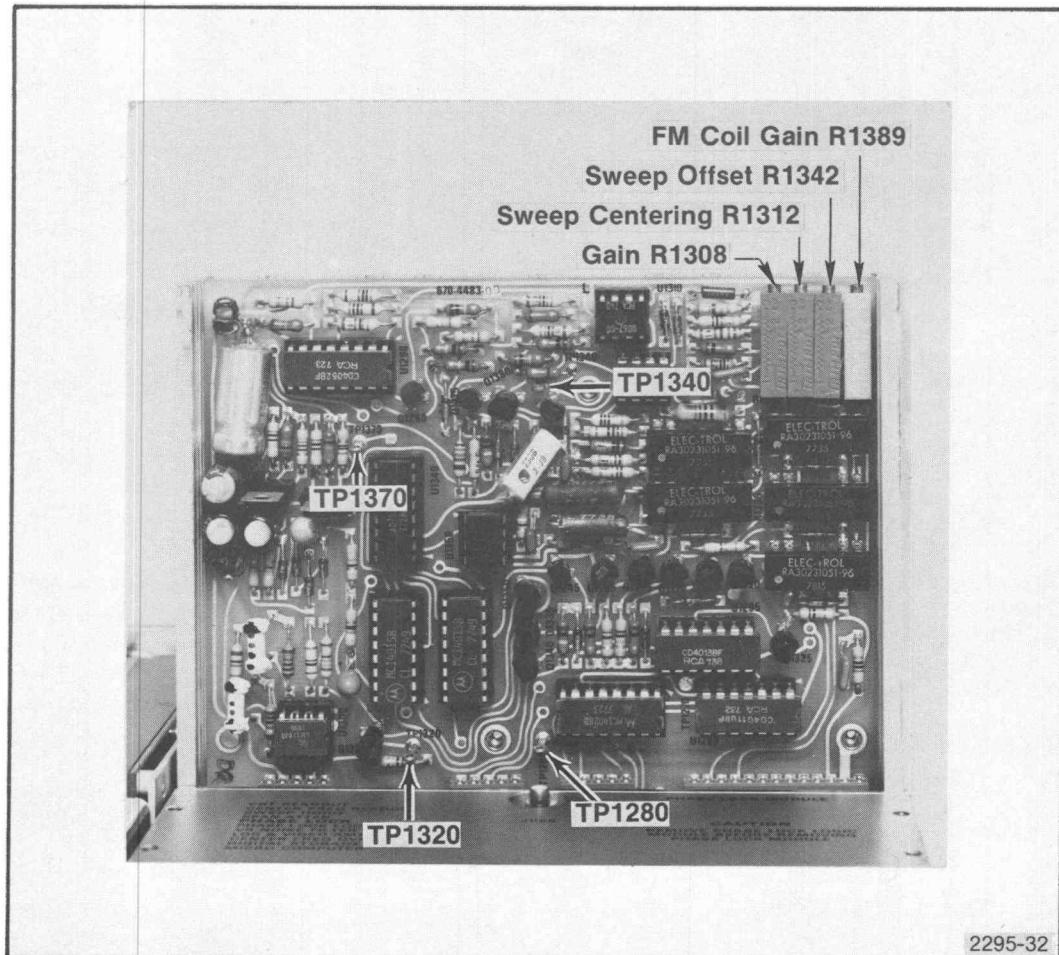
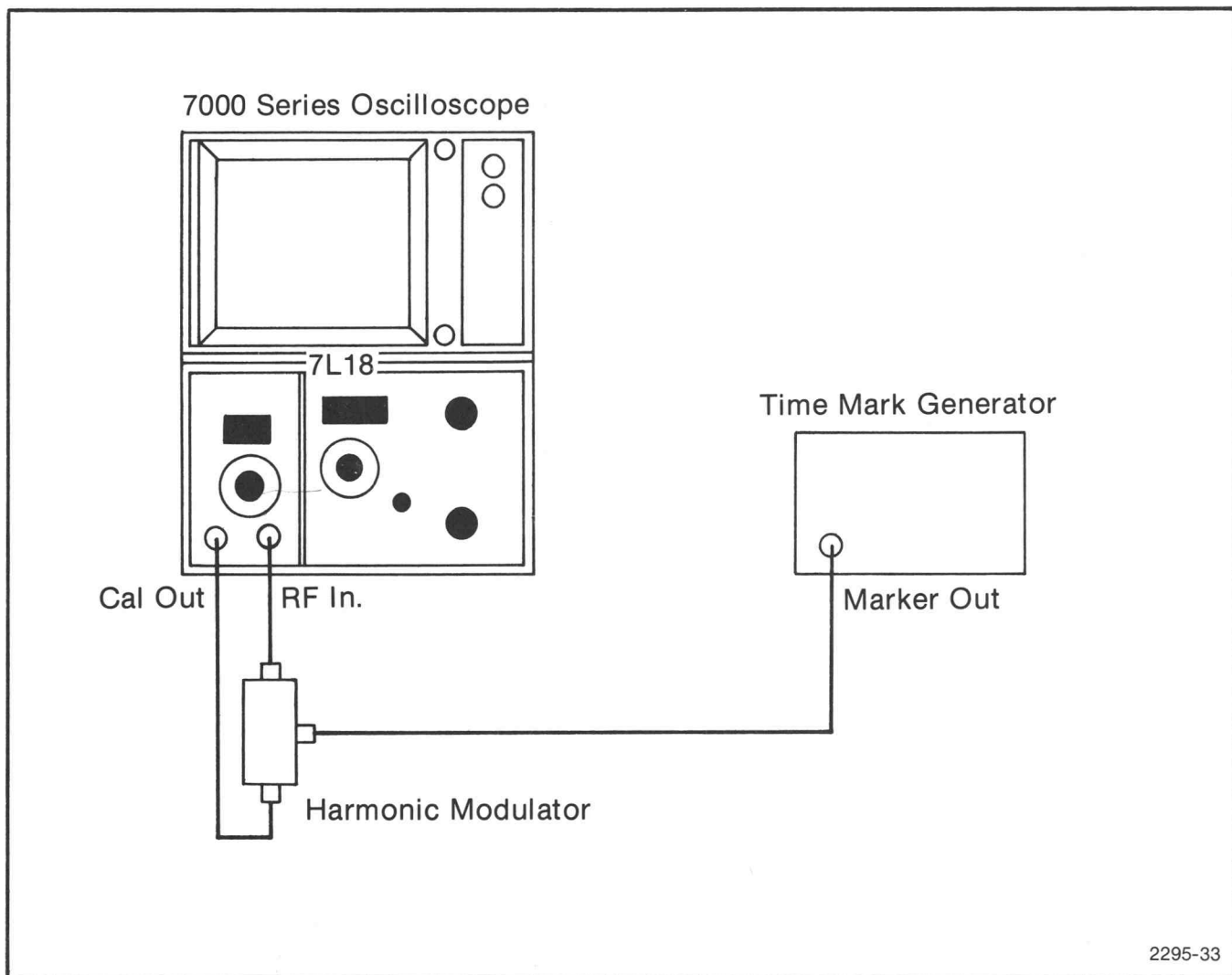

Fig. 4-24. Span Attenuator Test Points and Adjustments.



2295-33

Fig. 4-25. Equipment Setup for Calibrating Sweep Timing.

h. Connect test setup as shown in Fig. 4-25. The input signal to the 7L18 will be modulated by time-markers. Set the 7L18 front panel controls as follows:

CENTER FREQUENCY	2.0 GHz
Display Mode	10 dB/DIV
REFERENCE LEVEL	-30 dBm
RF Attenuator	0 dB
TRIGGERING	INT/EXT
TIME/DIV	20 ms
FREQ SPAN/DIV	2 MHz
RESOLUTION BANDWIDTH	300 kHz
Digital Storage	Off
PHASE LOCK	Off
PULSE STRETCHER	On

i. Apply 20 ms time marks to modulate the 2.0 GHz calibrator signal. Tune the signal to center screen. Change the Display Mode to 2 dB/DIV and reduce the FREQ SPAN/DIV to 0, keeping time markers on screen with the Center Frequency tuning control.

j. Detune the center frequency so positive trigger pulses are displayed and adjust the REF VAR for a triggered display (see Fig. 4-26).

k. Use the HORIZ POSITION control to align time marks to their respective graticule lines while adjusting the front panel SWP CAL for 1 marker/div.

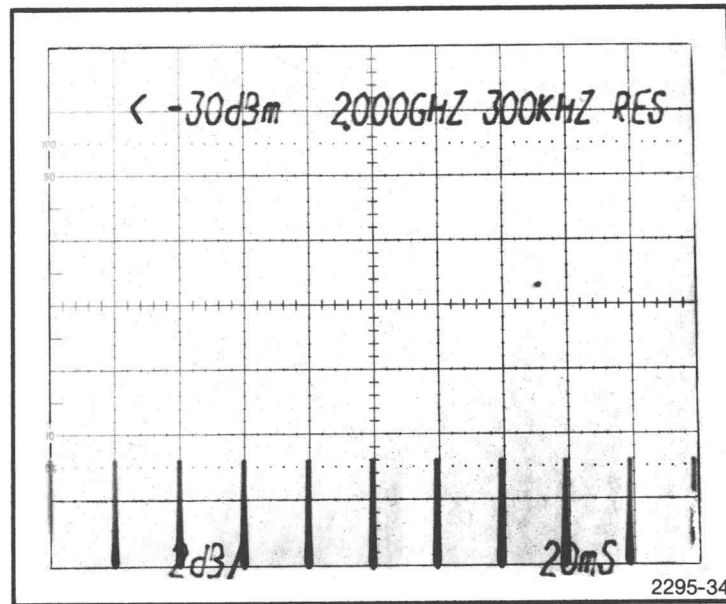

Fig. 4-26. Time Marks Displayed for Calibrating Sweep Timing.

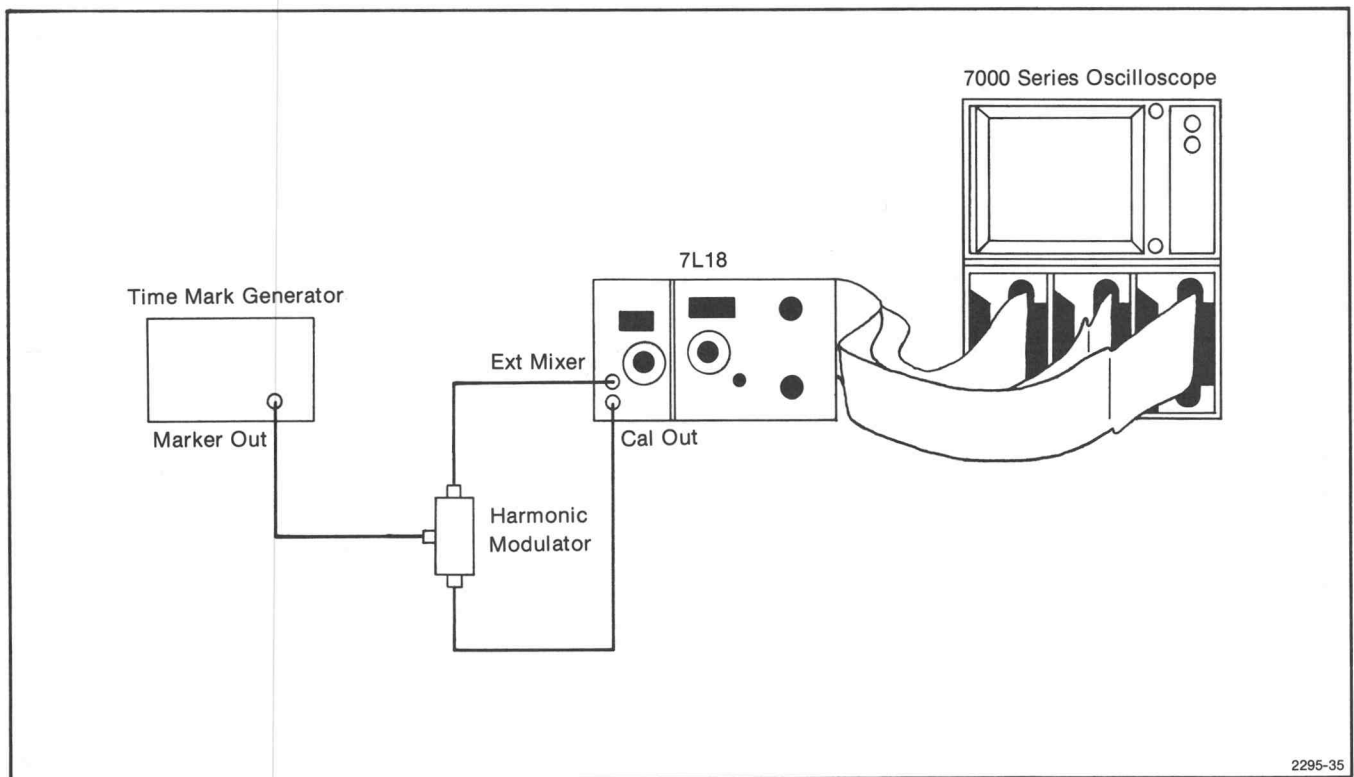

Fig. 4-27. Equipment Setup to Adjust and Calibrate Drive to FM Coil of the 1st LO.

2. Adjust or Calibrate the Drive to the 1st Local Oscillator FM Coil

NOTE

This adjustment procedure requires the sweep amplitude and timing to be within specifications. See Step 1.

a. Connect the test setup as shown in Fig. 4-27. Set the front panel controls as follows:

FREQ SPAN/DIV	1 MHz
Display Mode	10 dB/DIV
RESOLUTION BANDWIDTH	AUTO
TIME/DIV	AUTO
PEAKING	centered

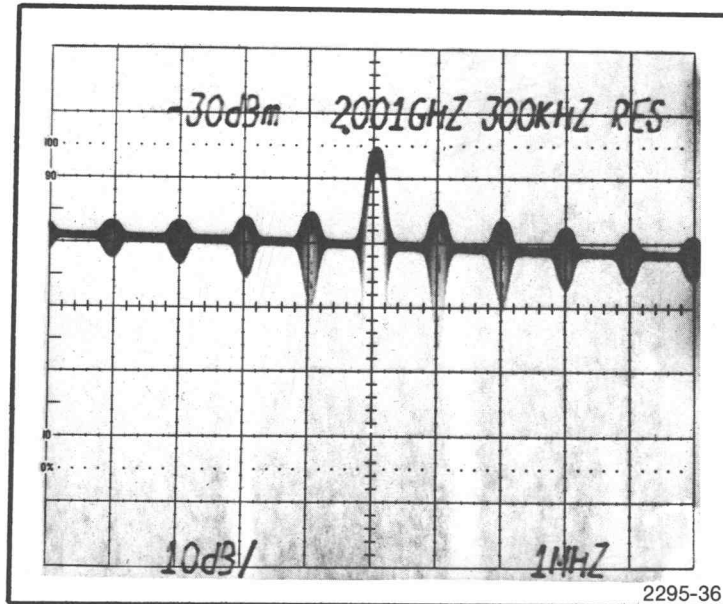

Fig. 4-28. 1 MHz Beat Notes as Seen on the Display for Calibrating the 1st LO FM Coil Drive.

b. Apply 1 μ s markers through the Harmonic Modulator to the 7L18 R.F. input.

c. Tune the CENTER FREQUENCY to keep the beat nodes aligned with the graticule lines while the FM Coil Gain, R1389, (see Fig. 4-24) is adjusted for one marker/div (see Fig. 4-28).

d. Disconnect the test equipment to the 7L18.

3. Adjust the 1st Local Oscillator Tuning Coil Drive Voltage and Calibrate Digital Voltmeter Readout

a. Set the front panel controls as follows:

Display Mode	LOG 10 dB/DIV
TIME/DIV	AUTO or 10 ms
Band Selection	1.5—3.5 (Band 1)
RESOLUTION BANDWIDTH	AUTO or 3 MHz
Reference Level	-30 dBm
FREQ SPAN/DIV	100 MHz
Digital Storage	Off

b. Apply the output of a 100 MHz Comb generator to the 7L18 RF INPUT. If a Comb generator is not available, apply the CAL OUT signal to the RF INPUT. If the CAL OUT is used, first verify that its performance is within specifications.

c. Adjust Tune Coil Slope R2172 (see Fig. 4-29) for 100 MHz markers per division. If using the Cal Out signal, adjust for 500 MHz per five divisions.

d. Using a DVM or a dc-coupled test oscilloscope, adjust RF Voltage (Adj R2352) on the Reference Voltage board (see Fig. 4-30) -10.0 volts between pin W and Tune Ref Gnd (pin J) on the Preselector Driver board (see Fig. 4-29).

e. Change the FREQ SPAN/DIV to 2 MHz and measure the voltage at pin T of the Preselector Driver board (see Fig. 4-29). Adjust CENTER FREQUENCY control for a reading of 0 volt (center frequency is not at the center of the band, or 2.490 GHz).

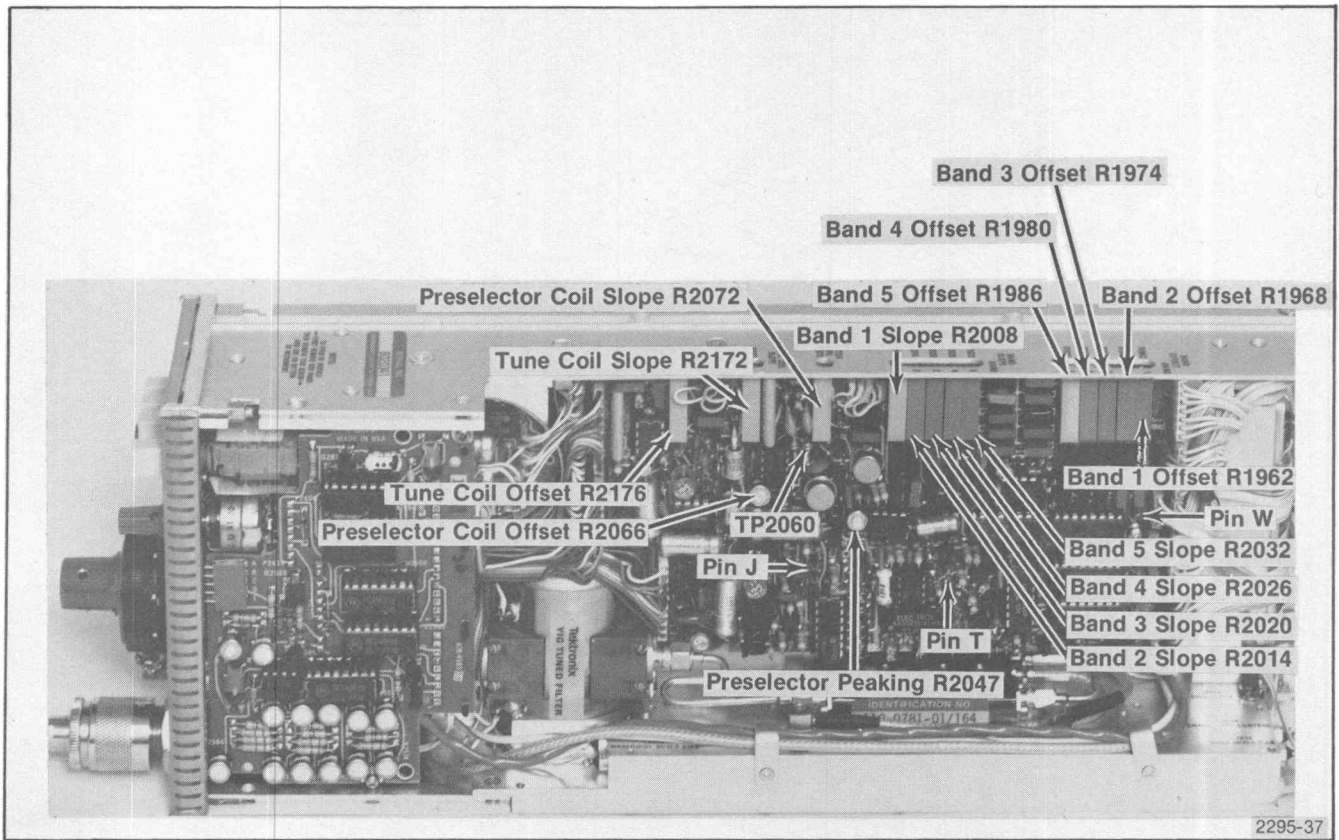

Fig. 4-29. Adjustments and Test Point Location on the 1st LO and Preselector Driver.

f. Adjust Tune Coil Offset R2176 (see Fig. 4-29) so the 2.5 GHz marker is on the far right graticule line. This is 10 MHz above center.

g. Press and release DEGAUSS. The 2.5 GHz marker should return to the far right graticule line. If it does not, readjust R2176 as necessary.

NOTE

If the preselector will not pass a signal, proceed to part n of this step. If it will pass a signal, continue with part h of this step.

h. Midrange the front panel Center Frequency CAL adjustment.

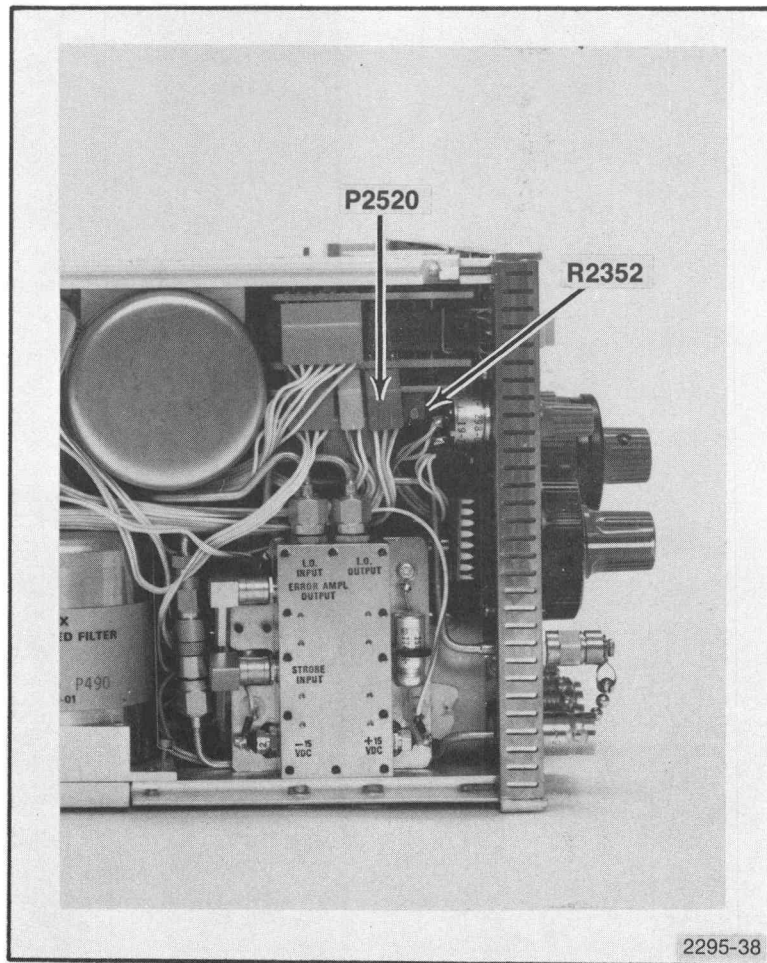

Fig. 4-30. Location of Reference Voltage Adjust and P2520.

i. Adjust Offset R475 (see Fig. 4-31) for a Center Frequency readout of 2.490 GHz.

j. Increase the span to 100 MHz/div and tune the 1.5 GHz signal to center screen.

k. Press the DEGAUSS button and decrease the SPAN/DIV to 2 MHz, keeping the signal centered with the tuning control.

l. Adjust Gain R455 on the Center Frequency DVM board (see Fig. 4-31) for a readout of 1.5 GHz.

m. Repeat parts i through l of this step to minimize interaction.

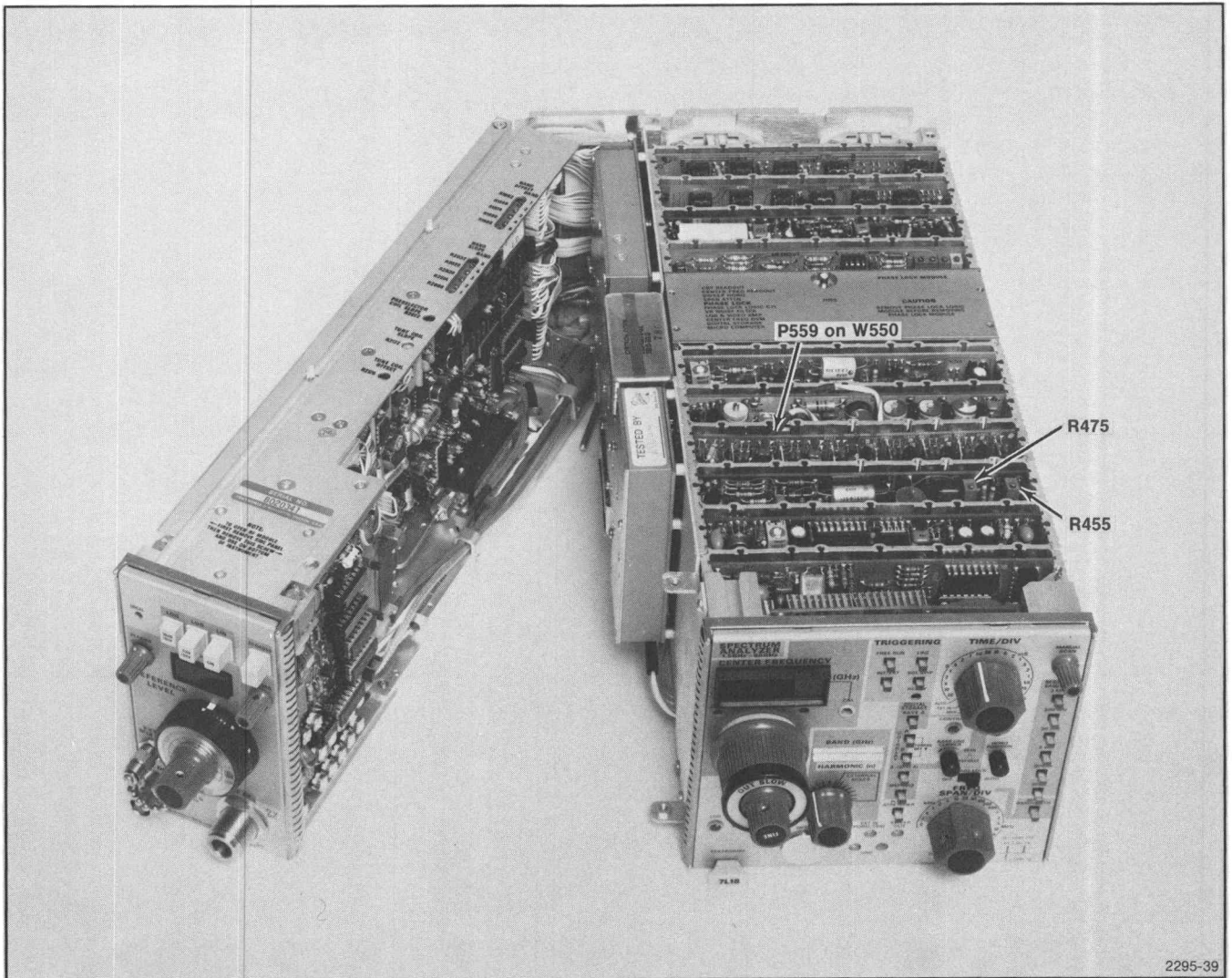

Fig. 4-31. Location of Adjustments on Center Frequency DVM.

n. Use the following procedure to calibrate the DVM only if the pre-selector will not pass a signal.

1. Apply the CAL OUT signal to the EXT MIXER input through a coaxial cable and BNC to SMA adapter.

2. With the FREQ SPAN/DIV at 2 MHz and the CENTER FREQUENCY set for 0 V at pin T of the Preselector Driver (see Fig. 4-29), the display should contain both the 2.5 GHz calibrator signal and its lower image response.

3. Press and release DEGAUSS, then adjust Tune Coil Offset R2176 (see Fig. 4-29) to position the 2.5 GHz marker on the far right graticule line.

4. With the front panel CAL adjustment centered, adjust Center Frequency DVM Offset R475 (see Fig. 4-31) for a readout of 2.490 GHz.

5. Tune the 1.5 GHz signal to center screen. As the 1.5 GHz signal approaches center screen, press and release DEGAUSS.

6. Adjust DVM Gain R555 (see Fig. 4-31) for a readout of 1.5 GHz.

7. Remove the Cal signal to the EXT MIXER input and replace the 50 Ω terminator.

4. Calibration of the Log Amplifier

a. To gain access to the adjustable components of this circuitry, the Log and Video Amp Module Assembly must be extended from the instrument. Remove the shield plate between the Log and Video Amplifier and Center Frequency DVM modules, then remove the Log and Video Amplifier module as previously described. Test equipment setup is shown in Fig. 4-32.

b. Disconnect the signal cable, W550, between the Log Amplifier board input and the output from the VR Noise Filter board (see Fig. 4-31).

c. Set the 7L18 front panel controls as follows:

FREQ SPAN/DIV	1 MHz
RESOLUTION BANDWIDTH	AUTO
RF ATTENUATOR	0 dB
REFERENCE LEVEL	-60 dBm
TIME/DIV	AUTO
Digital Storage	Off
REF VAR	CAL detent
Display Mode	Switches disengaged (out)

d. Apply a -50 dBm, 10 MHz signal from a signal generator through 10 dB and 1 dB step attenuators, to the input of the Log Amplifier, pins 1 and 2 of J559 (refer to Fig. 31 or 32).

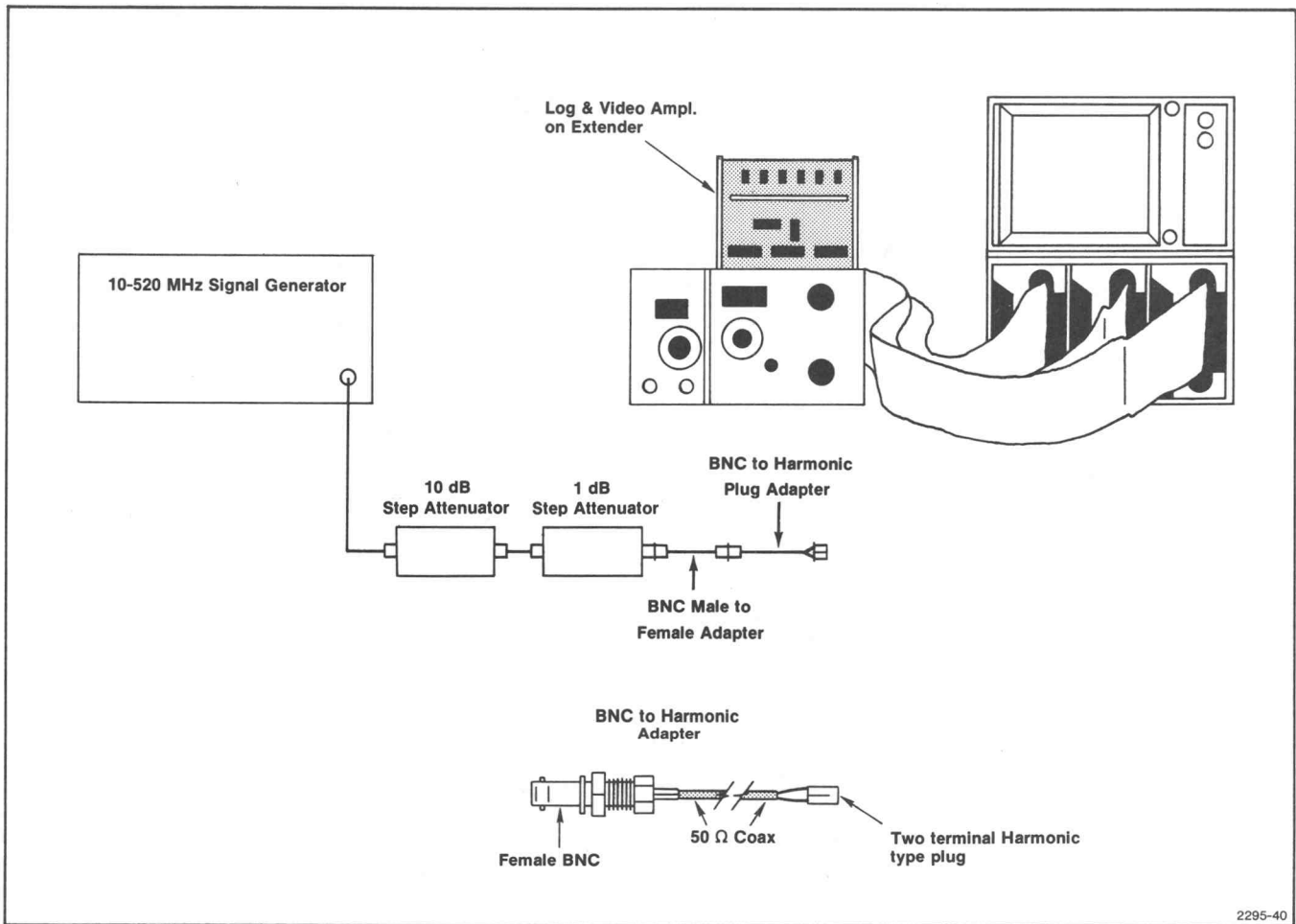

Fig. 4-32. Log and Video Amplifier Module on an Extender, Ready for Calibration.

e. Switch the REFERENCE LEVEL from -60 dBm to -100 dBm in 10 dB steps while adjusting front panel LOG CAL for one division increase per step.

f. Reconnect P2520 to the Display Mode board, set the REFERENCE LEVEL to -30 dBm, the Display Mode to 2 dB/DIV, and the signal generator output to 0 dBm.

g. Change the REFERENCE LEVEL 10 dB by switching to -20 dBm and adjust 2 dB/Div, R805, (see Fig. 4-33) for five divisions of change.

h. Set the Display Mode to 10 dB/DIV and the REFERENCE LEVEL to -30 dBm. Ensure the signal generator output is still 0 dBm.

i. Switch in 70 dB of attenuation in 10 dB steps and set 10 dB/div adjust, R725, (see Fig. 4-33) for the best 10 dB/div accuracy.

j. Return the step attenuators to 0 dB. Adjust 10 dB/div Reference Level R775 (see Fig. 4-33) for full screen signal.

k. Change the Display Mode to 2 dB/DIV. Adjust 2 dB/div Reference Level, R780, (see Fig. 4-33) for full screen signal.

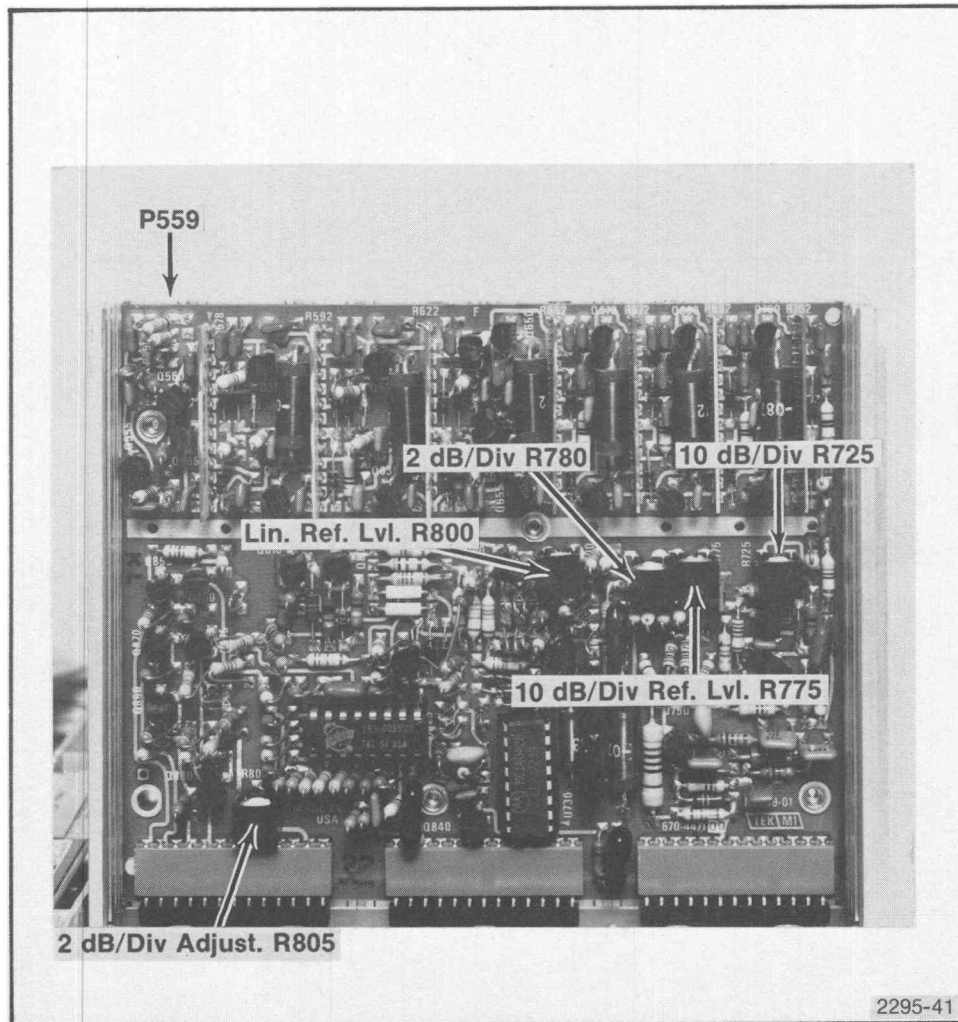

Fig. 4-33. Log and Video Amplifier Test Points and Adjustments.

l. Change the Display Mode to LIN. Adjust LIN Reference Level, R800, (see Fig. 4-33) for full screen signal.

m. Disconnect test setup, and reconnect cable W550 between the Noise Filter output and the input to the Log Amplifier board. Remove the extender and return the Log and Video Amplifier module to its normal position.

CAUTION

Ensure that the interconnect cable, W550, is in the VR Noise Filter board notch before installing the shield plate between the two module assemblies.

5. Calibration of the Phase Lock Control

The Phase Lock module must be operative and the Phase Lock Logic Control module on an extender. Test setup is shown in Fig. 4-34. This procedure checks beat-note levels into the Phase Lock Control, sets the loop gain and the 50 kHz span for phase lock operation.

a. Set Loop Gain, R1184, (see Fig. 4-35) fully counterclockwise (ccw).

b. Set the front panel FREQ SPAN/DIV to 50 kHz, and the Band selector to 1.5—3.5 GHz.

c. Replace the 50-ohm termination on the EXT MIXER port with a 3 dB miniature fixed attenuator.

d. Connect a voltage probe, from the test oscilloscope, to the junction of H24 and R1182 (see Fig. 4-35) on the Phase Lock Logic Control board.

e. Tune across band 1 for the lowest beat-note level as observed on the test oscilloscope (use the coarse position of the Center Frequency tuning control).

f. Remove the voltage probe from the junction of R1182-H24 and connect it to the center tap of R1184. Use a shorting strap to ground TP1190 (see Fig. 4-35).

g. Adjust R1184 for a 1 ± 0.2 V peak-to-peak beat signal.

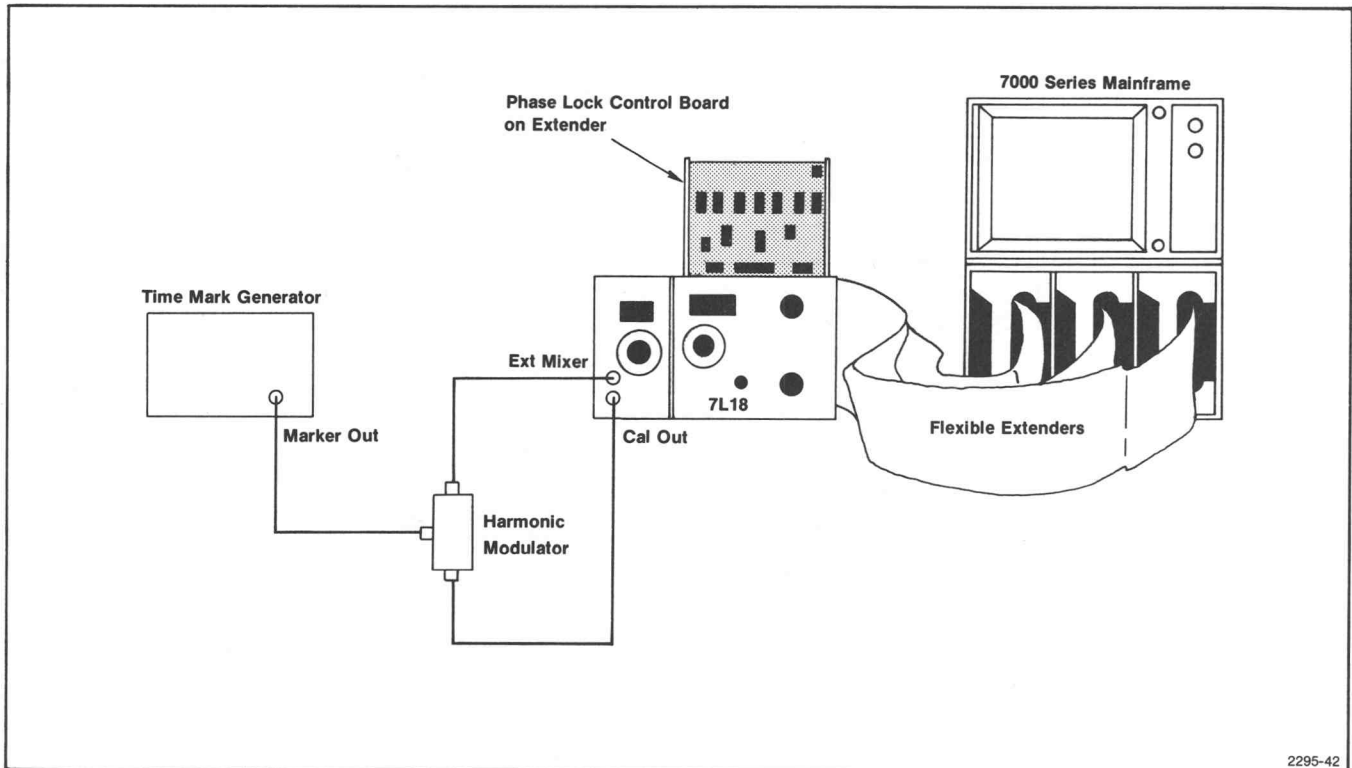

Fig. 4-34. Test Setup for Calibrating Phase Lock Control.

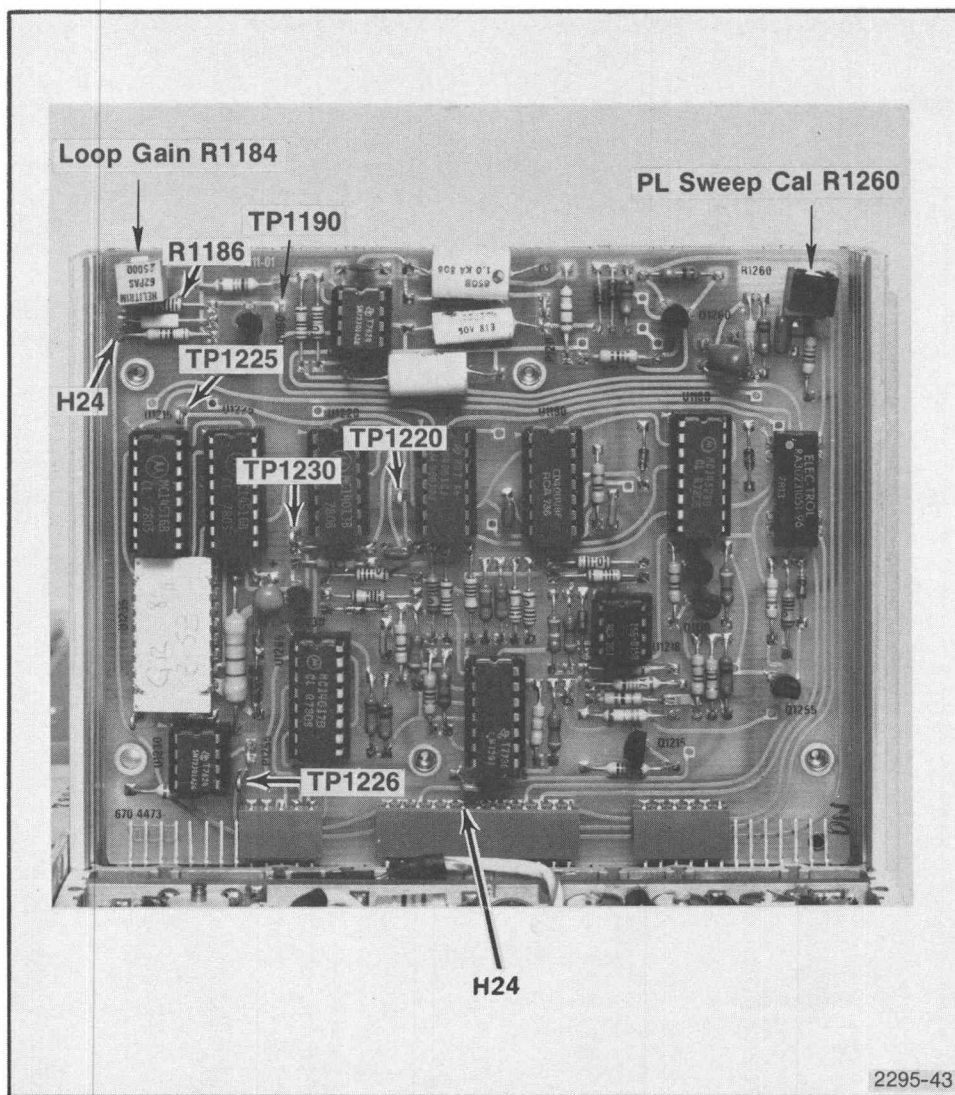

Fig. 4-35. Phase Lock Logic Control Test Points and Adjustments.

h. Remove the ground strap to TP1190 and replace the 3 dB attenuator with the 50-ohm TERMINATION.

i. Apply the CAL OUT signal through the Harmonic Modulator to the RF INPUT so the Calibrator signal is modulated with 20 μ s markers from the Time-Mark Generator (see Fig. 4-34).

j. With a 10 dB/DIV display, tune the 2.0 GHz calibrator signal to center screen; then reduce the FREQ SPAN/DIV to 50 kHz and the RESOLUTION BANDWIDTH to 3 kHz. Ensure PHASE LOCK is in the AUTO position. Set the TIME/DIV to 5 ms.

k. Adjust span for one marker/division with R1260 (see Fig. 4-35).

l. Change the SPAN/DIV to .2 MHz, and the Time-Mark Generator output to 5 μ s.

m. Adjust R1389 on the Span Attenuator (see Fig. 4-24) for one marker/division.

NOTE

R1389 is also an adjustment for the Sweep Amplitude and Timing (step 1 of this procedure). This readjustment ensures that the oscillator FM coil frequency span is correct over the center portion of the crt display.

n. Disconnect and remove external test equipment.

6. Presetting the Variable Resolution Gain Adjustments

- a. Test equipment setup is as shown in Fig. 4-36.
- b. Set the 7L18 controls as follows:

CENTER FREQUENCY	2.0 GHz
REFERENCE LEVEL	-30 dBm
TIME/DIV	5 ms
FREQ SPAN/DIV	0
RESOLUTION	300 Hz
Display Mode	2 dB/DIV
Digital Storage	Off

- c. Disconnect P3455 from the output of the VR Noise Filter (see Fig. 4-36) and connect a power meter (i.e., HP 435A/8489A) to connector J3455. (Use a bnc-to-harmonic adapter such as that described for Adjusting Log Amplifier

module.) Disconnect P3174 (cable is input to 300 Hz Filter, see Fig. 4-36 or 4-37) on the VR module. Apply a 10 MHz, -10 dBm signal, from the signal generator, through a coaxial cable and bnc-to-male Sealectro adapter to the cable plug, P3174.

d. Set the 30 Hz Level, R3245 (Fig. 4-37), about 10° from the full clockwise position and set R3235, 300 Hz Gain, to mid-range.

e. Adjust the frequency of the signal generator for maximum indication on the power meter, then adjust VR Gain R3265 (see Fig. 4-37) for 0 dBm reading on the power meter.

f. Disconnect the power meter from connector J3455 and reconnect the cable (W550) to J3455.

g. Remove the signal generator signal from P3174 and reconnect P3174 to J3174.

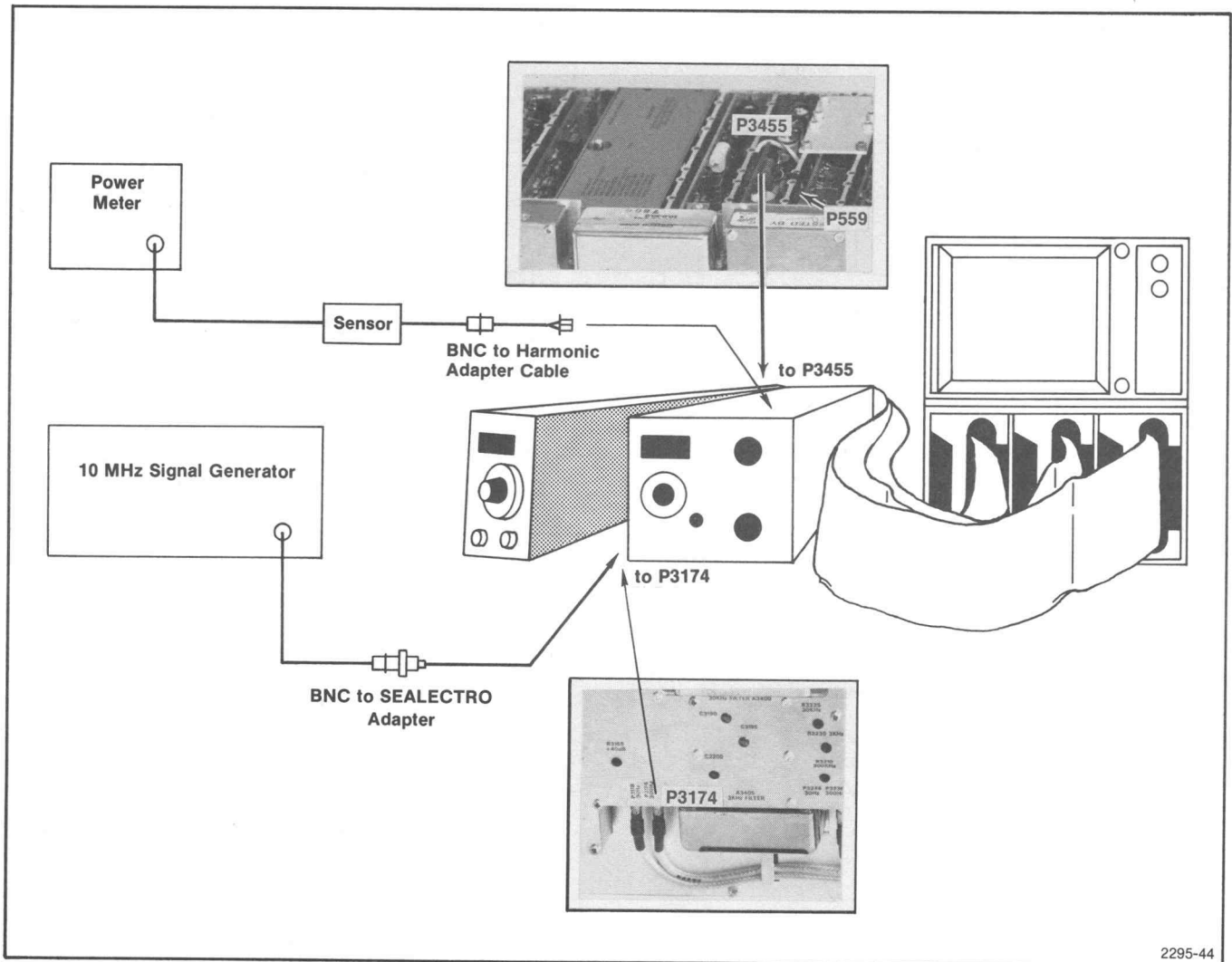

Fig. 4-36. Test Setup for Calibrating VR Circuits.

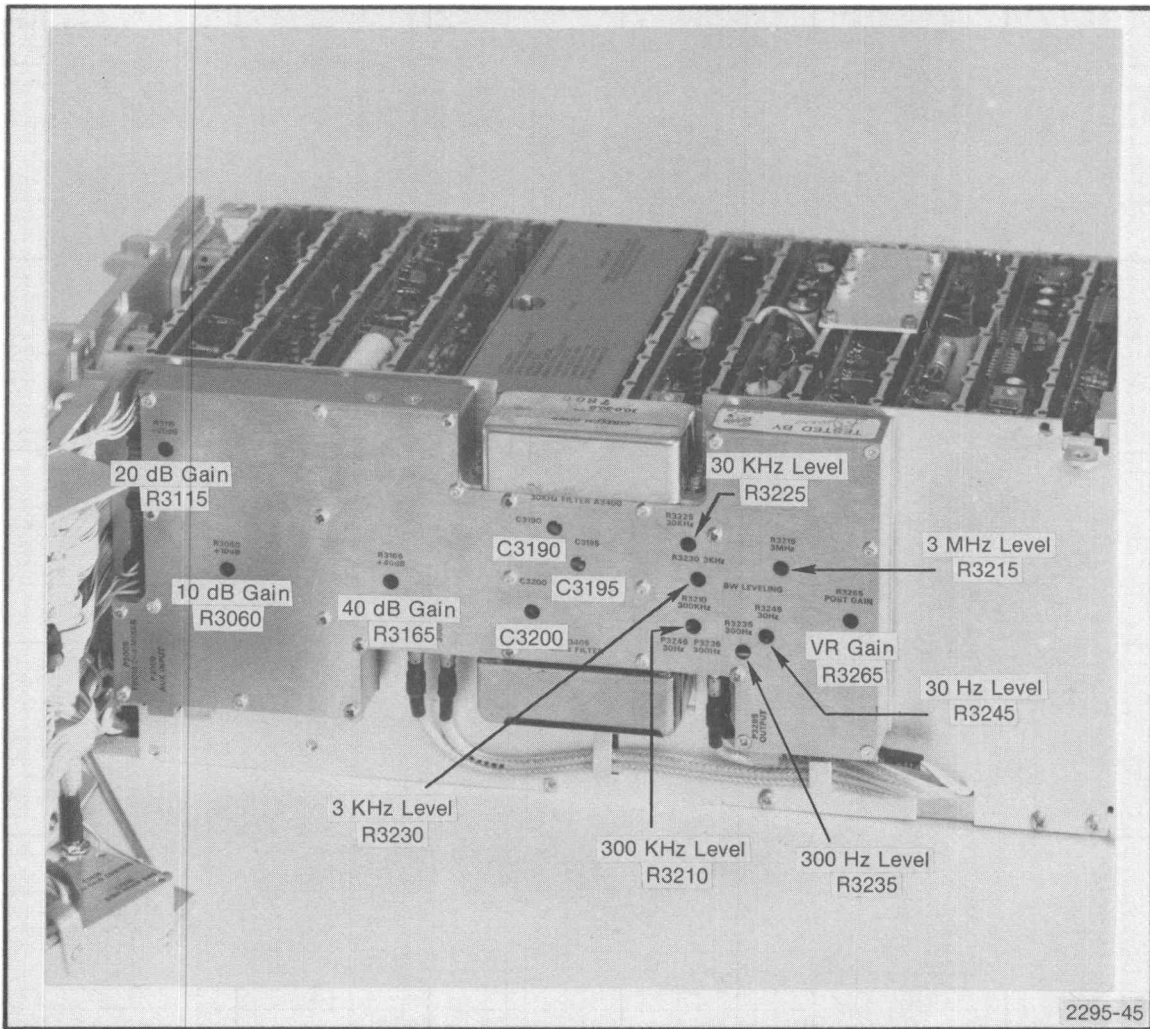

Fig. 4-37. Location of Connectors and Adjustments used When Calibrating the VR Circuits.

h. Disconnect P2484 (10 MHz Output on the 2nd Mixer assembly, see Fig. 4-38), then apply 10 MHz, -30 dBm signal from the signal generator through a 10 dB step attenuator and bnc-to-Sealectro adapter, to P2484.

i. Change the RESOLUTION BANDWIDTH to 30 Hz and adjust the frequency of the signal generator for maximum amplitude on the crt display.

j. Adjust the generator output gain for a display amplitude of seven (7) divisions. This will be the VR reference level for the other bandwidth selections.

k. Switch the RESOLUTION BANDWIDTH to 300 Hz and adjust the filter output gain, with 300 Hz Level R3235, (see Fig. 4-37), so the amplitude of the display equals the reference level established in part j.

l. Adjust the output of the remaining resolution bandwidth filters to the reference level with the following level adjustments (see Fig. 4-37):

3 kHz—adjust R3230

30 kHz—adjust R3225

300 kHz—peak C3190, C3195, and C3200; then adjust R3210

3 MHz—adjust R3215

m. Return the RESOLUTION BANDWIDTH to 300 Hz, then reduce the signal level 10 dB with the step attenuator and decrease the gain 10 dB by changing the REFERENCE LEVEL to -40 dBm.

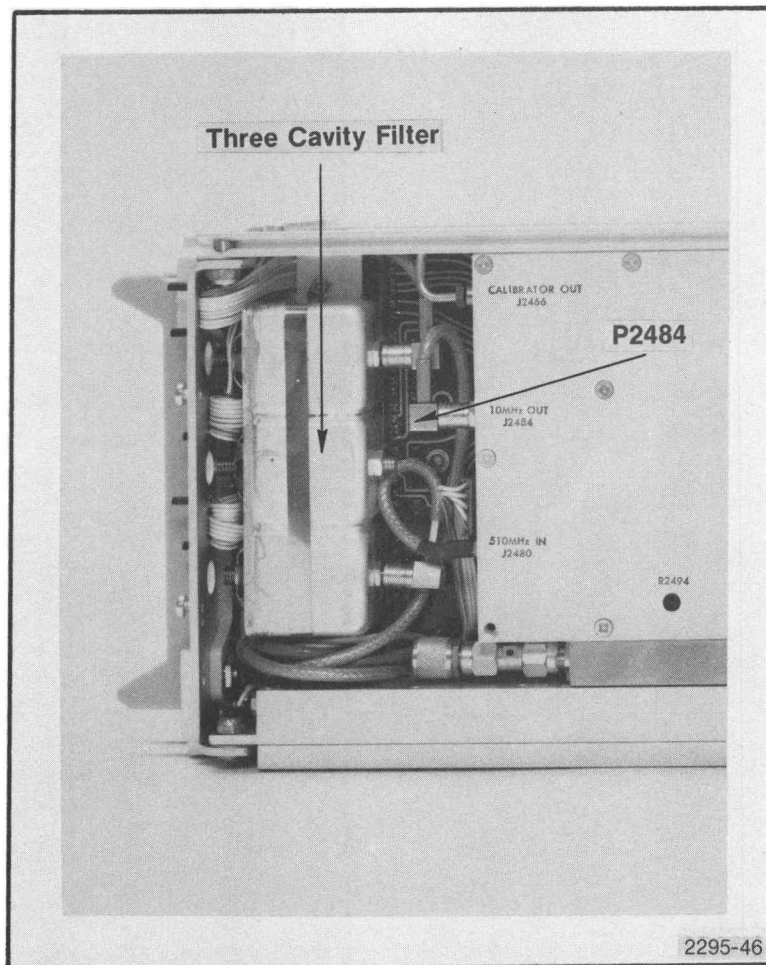

Fig. 4-38. Location of P2484 and 3-Cavity Filter.

n. Adjust 10 dB Gain R3060 (see Fig. 4-37) for a calibrated 10 dB of gain increase.

o. Reduce the input signal level an additional 10 dB for 20 dB of attenuation and set the REFERENCE LEVEL to -50 dB.

p. Adjust 20 dB Gain R3115 (see Fig. 4-37) for a calibrated 20 dB of gain increase.

q. Set the step attenuator for 80 dB of attenuation, the 7L18 REFERENCE LEVEL to -110 dBm.

r. Adjust 40 dB Gain R3165 (see Fig. 4-37) for a gain increase of 80 dB.

s. Disconnect the test equipment setup, replace P2484 to the output of the 2nd Mixer.

7. Calibration of the 510 MHz IF and Local Oscillators

NOTE

The 510 MHz IF circuits (chain) should only require calibration when the IF amplifier, waveguide band, or coaxial band resonator have been replaced and there is a problem getting the 7L18 to meet frequency response characteristics. A Return Loss Bridge is used to set the return loss.

a. This procedure requires the removal of the cover plate shown in Fig. 4-39. Use a 5/64" Allen driver to remove the 21 screws.

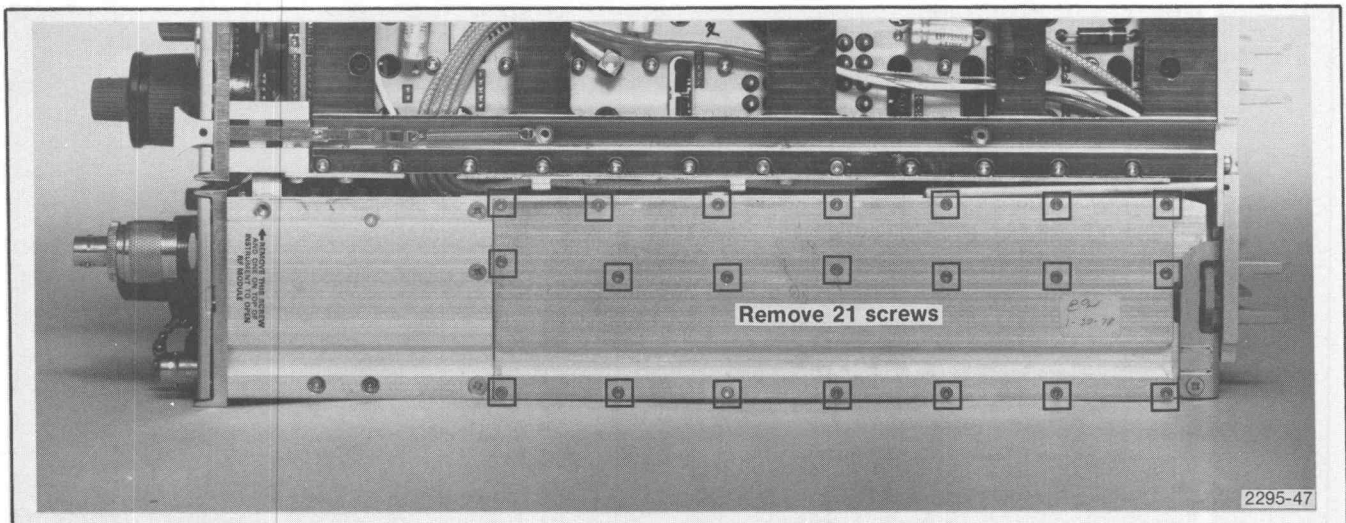

Fig. 4-39. Bottom of 7L18 Showing Location of 510 MHz IF Module.

- b. Test equipment setup is shown in Fig. 4-40A.
- c. Disconnect P40 and P44 from J2824 and J2816 (Fig. 4-40 or 4-41).
- d. Apply a 510 MHz, -50 dBm signal from a 50Ω signal source through a dc blocking capacitor to J2824 (Fig. 4-40A).
- e. Set the 7L18 band selector to 1.5—3.5 GHz and adjust REFERENCE LEVEL for an on-screen indication. It may be necessary to adjust Band 1 Gain R2574 on the Vertical Microcomputer Interface board (see Fig. 4-43), to midrange if a signal is not on-screen.
- f. Adjust Coaxial Resonator input tuning with C2821 (see Fig. 4-42) for maximum deflection.
- g. Remove the signal from J2824 and reconnect P40 to J2824, then apply the 510 MHz signal to J2816 (Fig. 4-41).
- h. Adjust Waveguide REsonator input tuning with C2815 (Fig. 4-42) for maximum deflection.
- i. Remove the signal from J2816 and reconnect P44 to J2816.

NOTE

After the proper gain has been established through the 510 MHz IF, a return loss bridge should be used to adjust the return loss in the coaxial and waveguide resonators of the 510 MHz IF. If the return loss is not correct, noise levels and gain levels could be in error.

j. Connect test equipment as shown in Fig. 4-40B. Apply a 510 MHz, -20 dBm signal through a vswr bridge to a test spectrum analyzer. Set the test spectrum analyzer Resolution Bandwidth to 3 MHz, Reference Level to -30 dBm, and Span/Div to 1 MHz. Set the signal level on the test spectrum analyzer to the top graticule line with the REF VAR control. Connect the second vswr output through a dc blocking capacitor to J2816 of the spectrum analyzer under test.

k. Measure the return loss at 510 MHz. If return loss is less than 12 dB down from the reference, adjust C2815 (Fig. 4022) until the loss is at least 12 dB down.

l. Remove the signal from J2816 and reconnect P44; then remove P40 from J2824 and apply the signal to J2824. Measure the vswr of the coaxial band resonator.

m. If the return loss is less than 12 dB, adjust C2821 (Fig. 4-42) until the loss is at least 12 dB at 510 MHz.

Disconnect the signal to J2824 and reconnect P40. Reinstall the 510 MHz IF amplifier cover assembly and disconnect the test equipment.

8. Calibration of the 500 MHz Local Oscillator (CAL OUT)

a. Turn the POWER off, remove the cover plate on the 2nd Mixer and 500 MHz Local Oscillator assembly and the copper shield over the 2nd Mixer section (see Fig. 4-43). Set the front panel controls as follows:

CENTER FREQUENCY	2.0 GHz
FREQ SPAN/DIV	1 MHz
RESOLUTION BANDWIDTH	AUTO
TIME/DIV	AUTO
Display Mode	2 dB/DIV

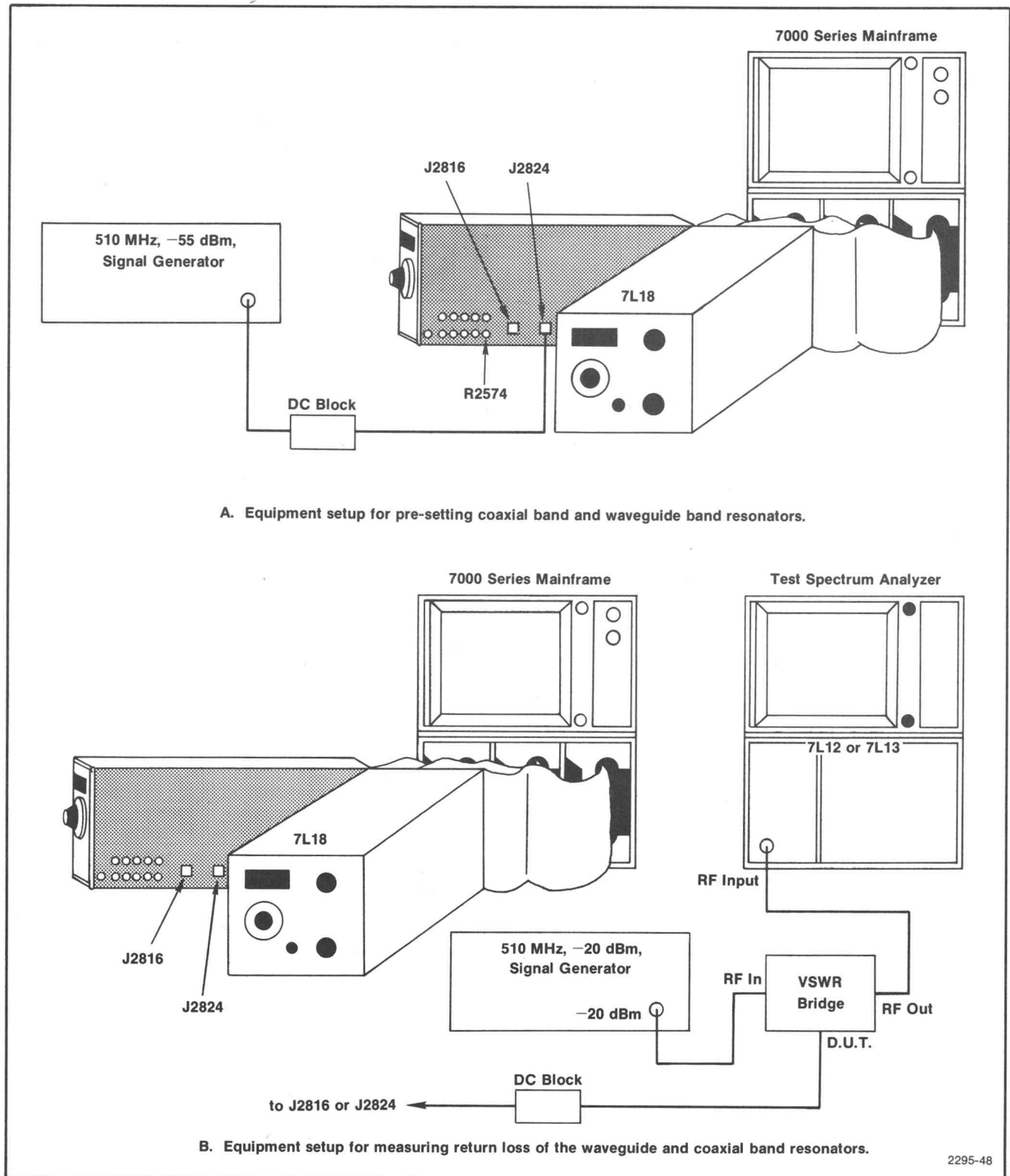

Fig. 4-40. Test Setup for Calibrating 510 MHz IF.

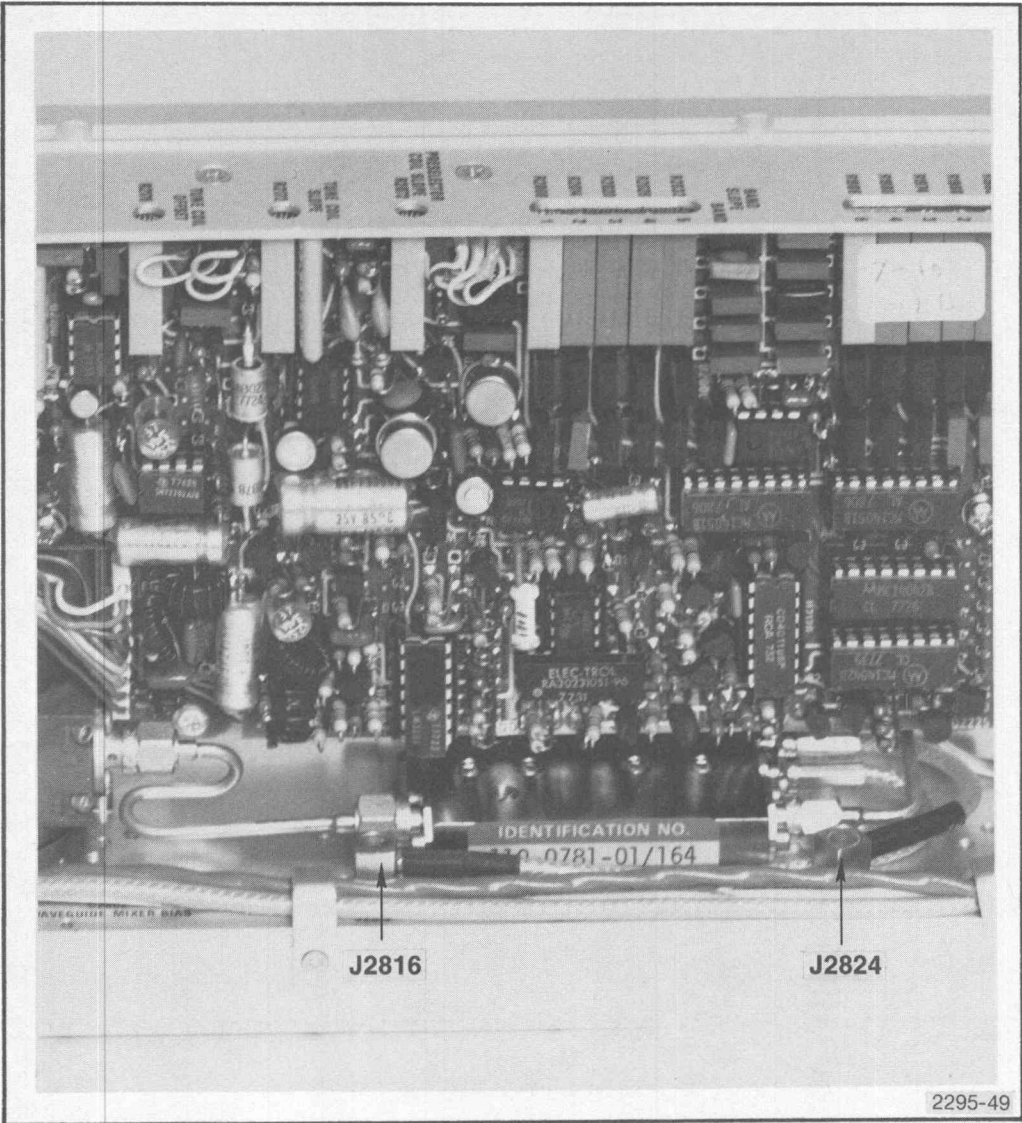

Fig. 4-41. Location of J2824, J2816 and Adjustments on Microcomputer Interface Board.

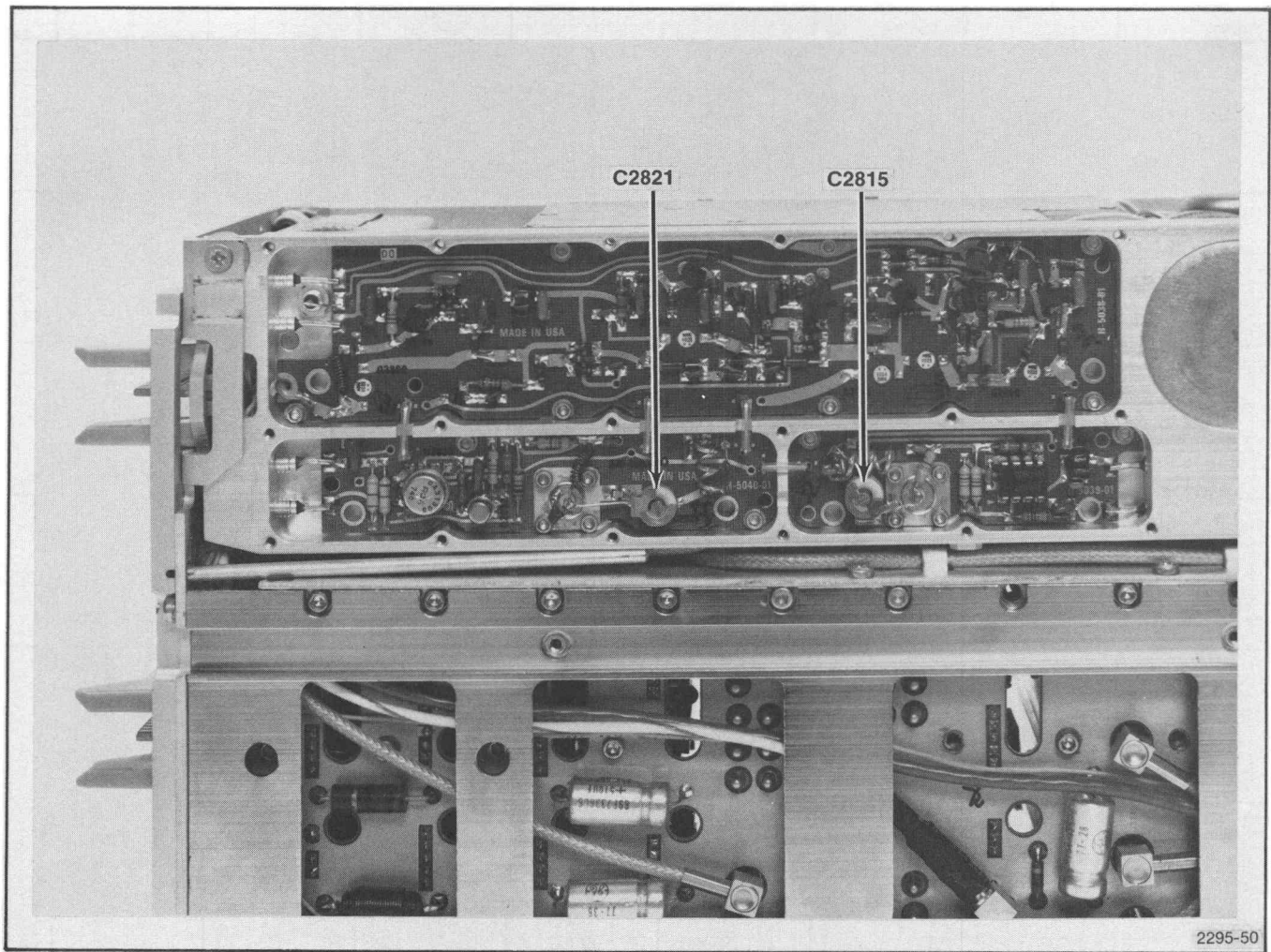
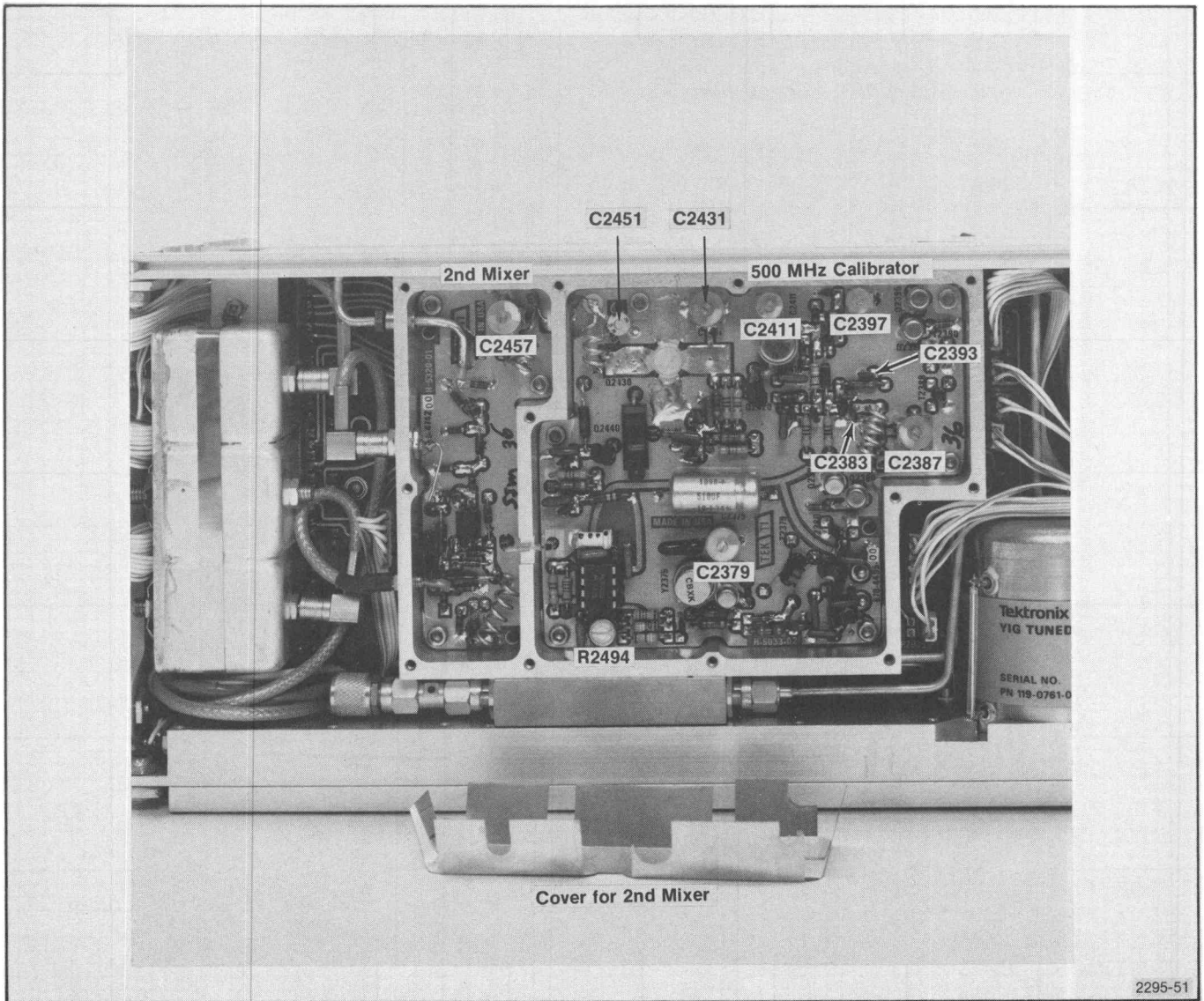

Fig. 4-42. Location of C2821 and C2815.



2295-51

Fig. 4-43. 500 MHz Calibrator and 2nd Mixer Adjustment and T.P. Locations.

Calibration—7L18 Service

b. Turn Power on. Use a voltmeter or test oscilloscope voltage probe to measure the voltage across C2383, and adjust C2379 for a voltage dip (see Fig. 4-43). The voltage value at the dip can be expected to be approximately 13.8 volts.

c. Measure the voltage across C2393 as C2387 is adjusted for a voltage dip. The voltage at the dip can be expected to be approximately 13.8 volts. Adjust R2494 ccw.

d. Apply the CAL OUT signal to the RF INPUT of the 7L18 or to a test spectrum analyzer and tune one of the 500 MHz markers to center screen.

e. Adjust the remaining trimmer capacitors (C2397, C2431, C2451, C2457, and C2411) for maximum signal amplitude (see Fig. 4-43).

f. Replace the shield and cover, tune the test spectrum analyzer to 2.0 GHz, and note the output level of the CAL OUT signal. Adjust R2494 for an indicated -30 dBm output.

g. Now use the procedure described in the Performance Check part to measure the calibration output (refer to step 2), calibrate the output to an accurate -30 dBm, 2.0 GHz with R2494.

9. Calibration of Digital Storage

a. Apply the CAL OUT signal to the RF Input and set the front panel controls as follows:

Display Mode	LOG 10 dB/DIV
Band Selection	1.5—3.5
CENTER FREQUENCY	2.5 GHz
TIME/DIV	AUTO
RESOLUTION BANDWIDTH	AUTO
FREQ SPAN/DIV	200 MHz
BASELINE CLIPPER	Fully cw

b. Tune the 2.5 GHz calibrator signal to center screen so the display covers the 1.5 to 3.5 GHz span. Activate and de-activate DISPLAY A and adjust Horiz Offset R3507 (see Fig. 4-44) until the stored 2.5 GHz signal is at the same horizontal point as the non-stored display.

d. Repeat as necessary to compensate for any interaction between the Horiz Offset and Horiz Gain adjustments.

e. Change the REFERENCE LEVEL to -20 dBm, switch to the non-store mode and tune the 2.0 GHz signal to center screen. Reduce the SPAN/DIV to 100 kHz, switch the RESOLUTION BANDWIDTH to 300 kHz, and the Display Mode to 2 dB/DIV.

f. Adjust PEAKING for maximum signal amplitude. Signal amplitude should be about three divisions.

g. Activate and de-activate DISPLAY A as the Vert Offset is adjusted with R3519, (see Fig. 4-44) until the stored signal amplitude is the same as the non-store amplitude.

h. Return the REFERENCE LEVEL to -30 dBm and with DISPLAY A de-activated (storage off), note the amplitude of the signal (approximately eight divisions).

i. Activate and de-activate DISPLAY A as the Vert Gain is adjusted with R3510, (see Fig. 4-44) so the stored display amplitude equals the non-store display.

j. Because of interaction, these two adjustments should be repeated until the stored display is calibrated to that of the non-store display.

10. Setting the Constant "K" for the Zero Reference of the B-SAVE A Display

When B-SAVE A is selected, the expression implemented is (B-SAVE A)-k, where "K" is a constant set by the input data for an 8 to 4 line encoder, U3566. Each bit will move the reference level about 0.2 of a minor division. The following procedure sets the value of "K" to move the B-SAVE A reference level.

a. Estimate the amount of shift and direction the reference level is to be shifted.

b. Turn the POWER off and remove the Digital Storage module.

NOTE

Refer to the Adjustment or Component Access instructions at the beginning of this part.

c. Separate the Digital Storage board from the Interface board. Pull the boards apart from their interconnecting pins evenly so the pins are not bent.

d. Connect or disconnect resistors R3561 through R3568 (see Fig. 4-45) to acquire the desired "K" factor or reference level.

e. Replace circuit boards and check operation.

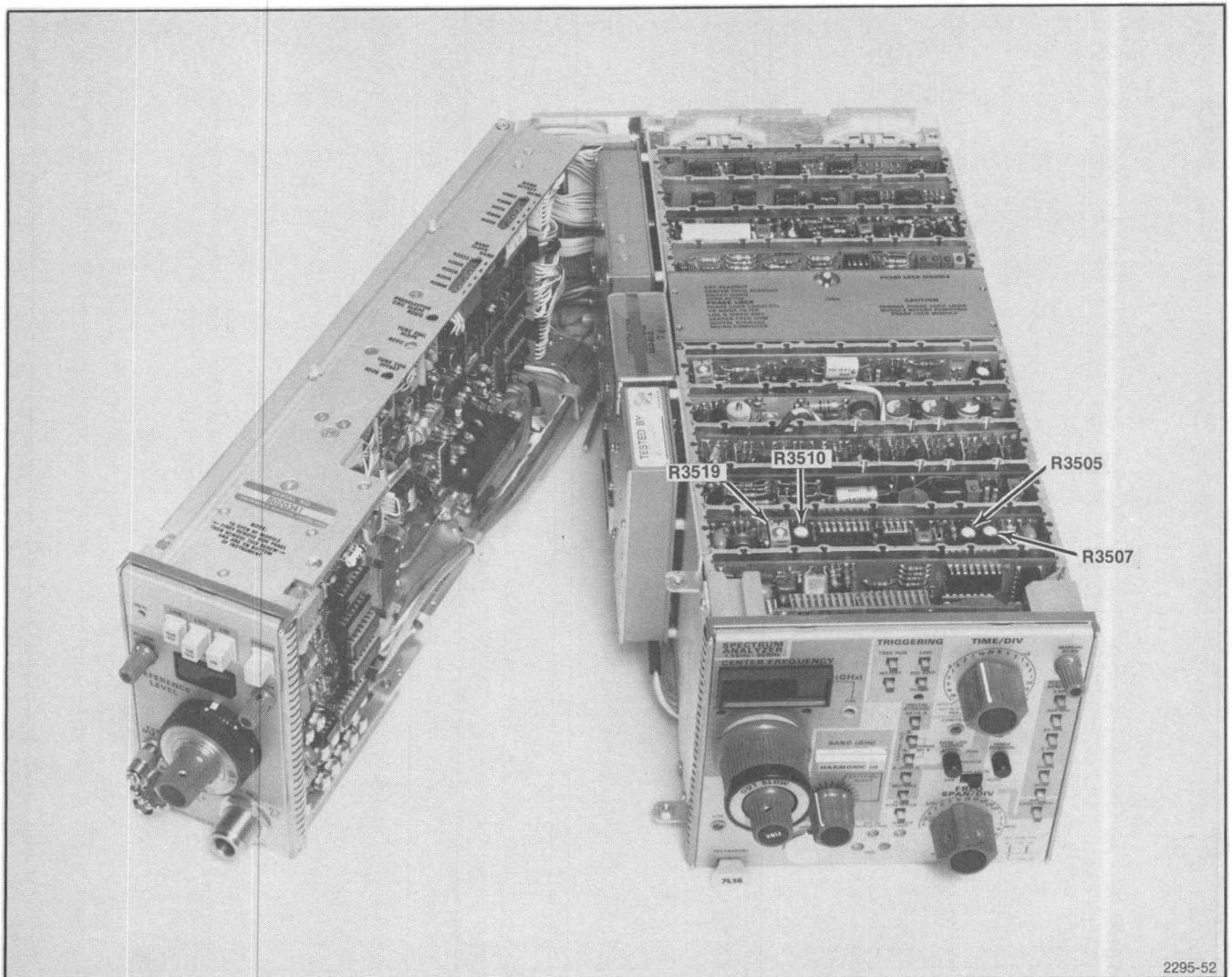

2295-52

Fig. 4-44. Digital Storage Calibration Adjustments.

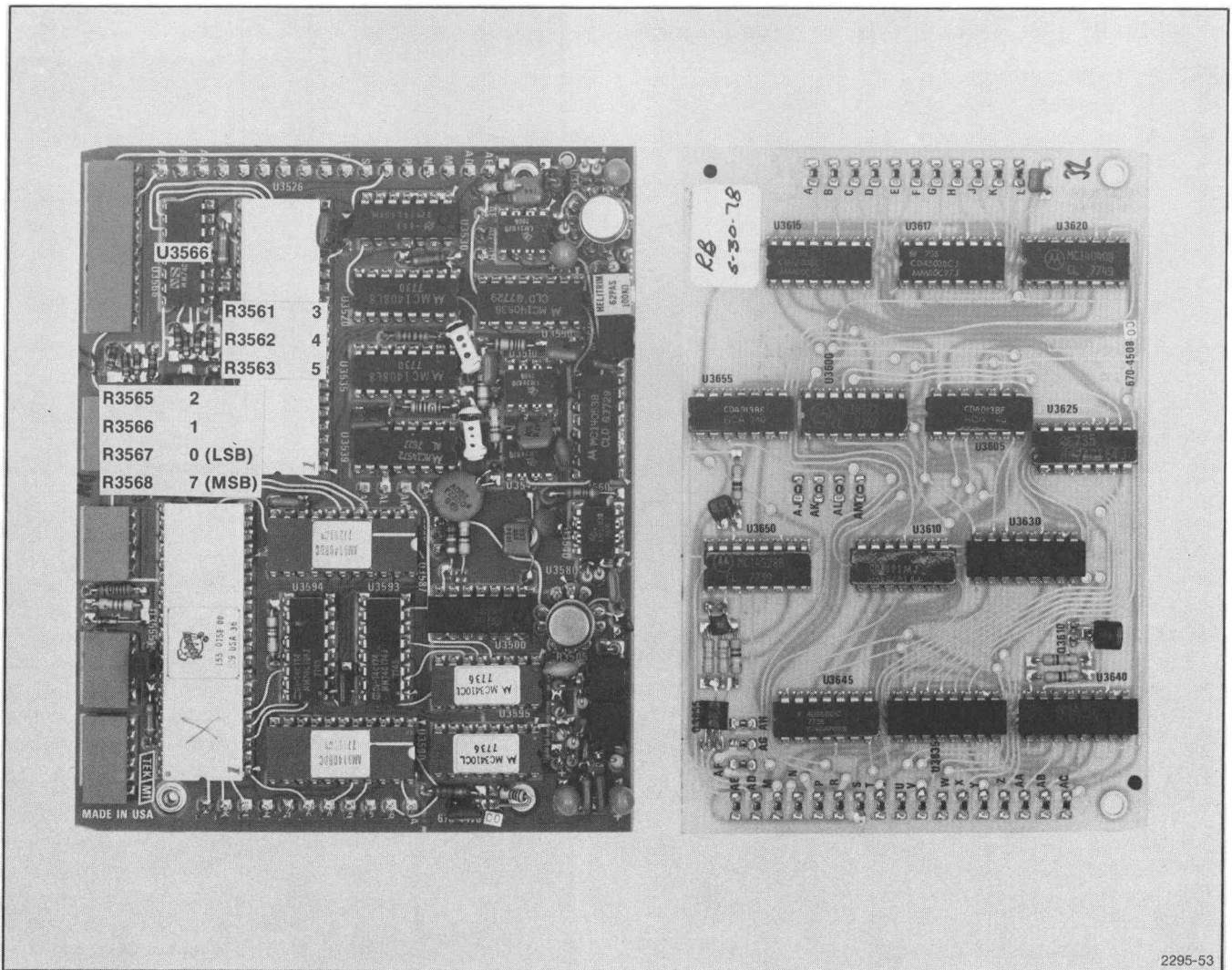

Fig. 4-45. Location of B-SAVE A Reference Level Positioning Resistor Matrix.

11. Calibration of the Resolution Bandwidth and Shape Factor

a. Set the front panel controls as follows:

CENTER FREQUENCY	2.0 GHz
FREQ SPAN/DIV	5 MHz
RESOLUTION	300 kHz
Vertical Mode	2 dB/DIV
REFERENCE LEVEL	-30 dBm
TIME/DIV	20 ms
DIGITAL STORAGE	DISPLAY A/DISPLAY B
PHASE LOCK	AUTO

b. Apply the CAL OUT signal to the RF INPUT and tune the Calibrator signal to center screen, then decrease the SPAN/DIV to 50 kHz, RESOLUTION BANDWIDTH to 30 kHz.

c. Tune the signal to center screen to establish filter center, then increase the RESOLUTION BANDWIDTH to 300 kHz.

NOTE

If the 3 MHz filter is out of calibration, a satisfactory display of the 300 kHz filter may not be possible. If this is the case, adjust the 3 MHz filter and then proceed with the 300 kHz filter adjustments.

d. Adjust the 300 kHz filter and the 300 kHz Noise Filter with C3190, C3195, C3200, C3425, C3436, and C3446 (see Fig. 4-46) for the best amplitude, symmetry, and shape around the 3 kHz reference center frequency.

e. Change the SPAN/DIV to 1 MHz and tune the signal to center screen with a RESOLUTION BANDWIDTH of 30 kHz.

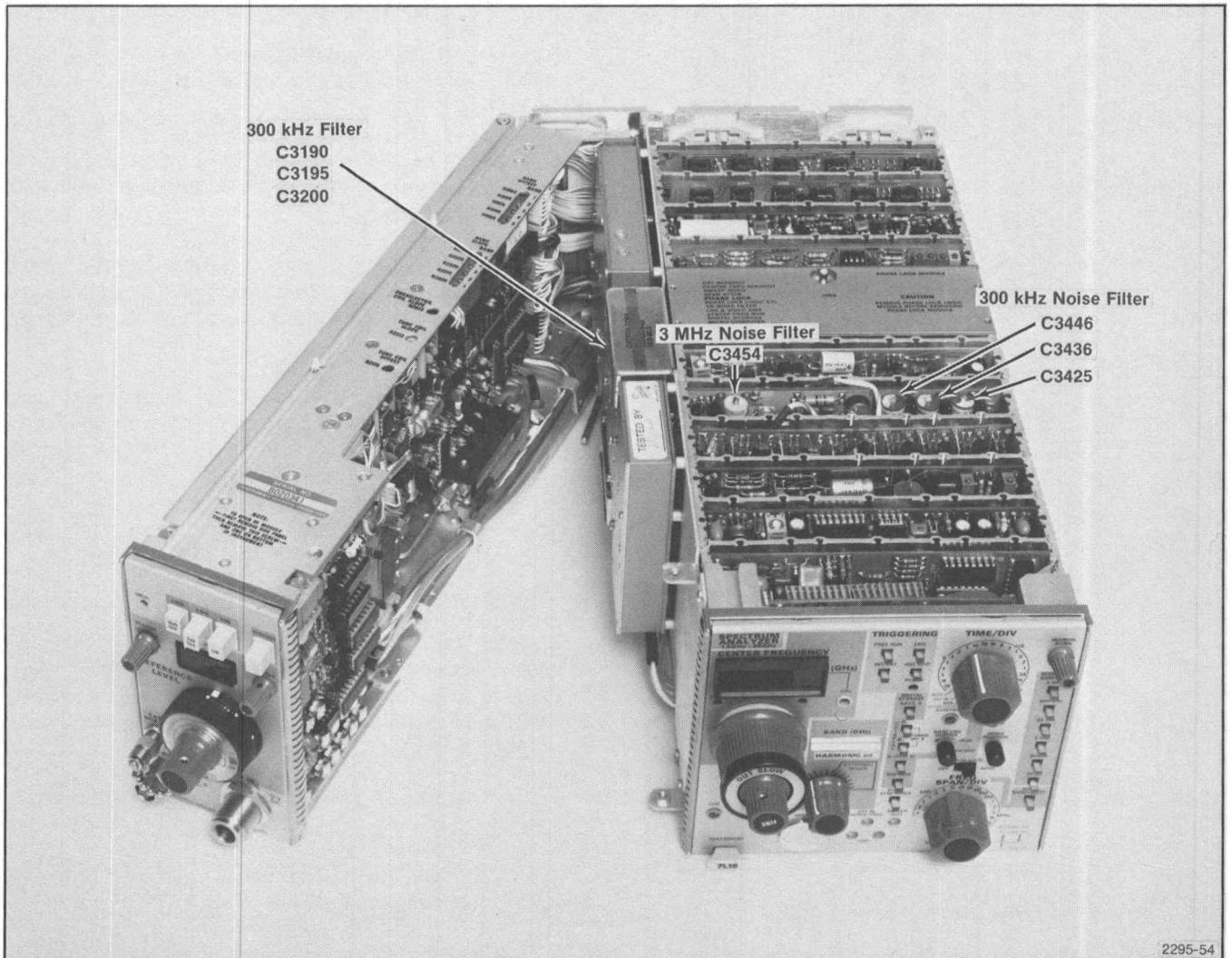

Fig. 4-46. Adjustments for 300 kHz Filter, 300 kHz Noise Filter, and 3 MHz Noise Filter.

2295-54

f. Change the RESOLUTION BANDWIDTH to 3 MHz, then adjust the three cavity filter (see Fig. 4-47) with a 7/64" Allen drive wrench, and the 3 MHz Noise Filter with C3454 (see Fig. 4-45) for the best amplitude, symmetry, and shape around the 30 kHz reference center frequency.

g. Re-adjust filter amplitude levels, using 30 Hz filter amplitude as the reference. Refer to Step 6 for this procedure.

h. Check all filters for characteristic bandwidth $\pm 20\%$.

i. Check 3 MHz, 300 kHz, 30 kHz, 3 kHz, and 300 Hz for a shape factor of 4:1 or better (refer to Performance Check portion of this procedure). Check 30 Hz filter for shape factor of 12:1 or better.

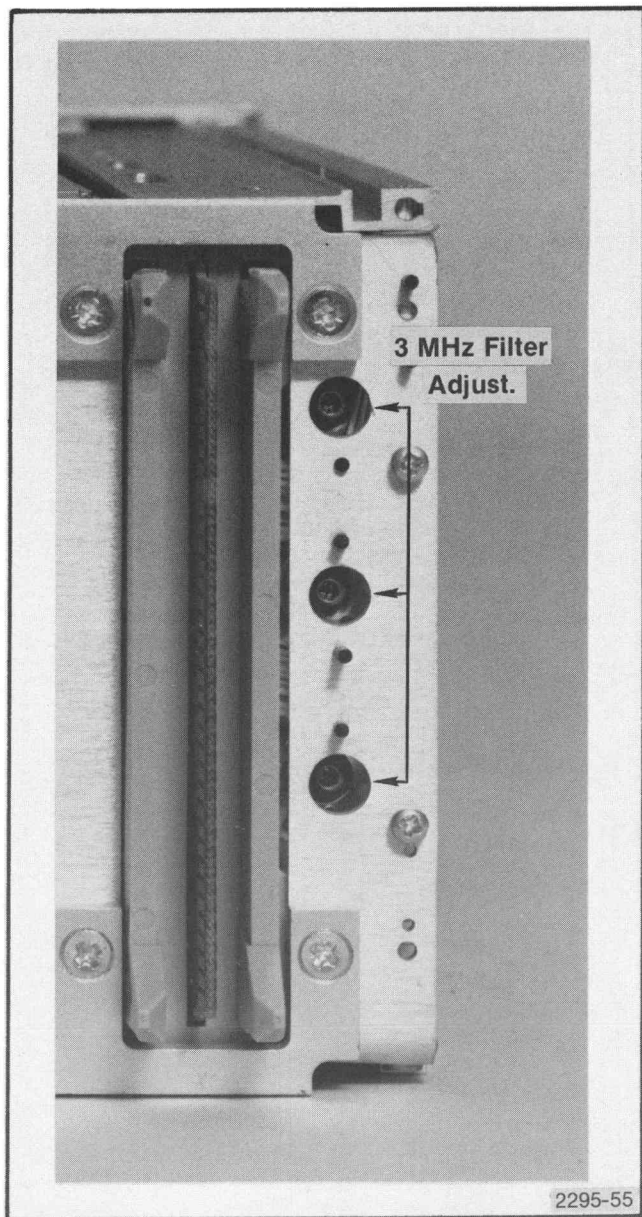

Fig. 4-47. Location of 3 MHz, Three-Section Filter Adjustments.

12. Input compression Check (≥ -22 dBm, 1.5—1.8 GHz; ≥ -18 dBm, 1.8—18 GHz)

a. Apply the CAL OUT signal to the RF INPUT and set the front panel controls as follows:

CENTER FREQUENCY	2.0 GHz
Vertical Display	2 dB/DIV
FREQ SPAN/DIV	2 MHz
RESOLUTION BANDWIDTH	3 MHz
RF ATTEN	0 dB
REFERENCE LEVEL	-30 dBm
TIME/DIV	AUTO

b. Tune the calibrator signal to center screen, peak the signal amplitude with the PEAKING control, then adjust the AMPLITUDE CAL for a signal amplitude of six divisions.

c. Change the REFERENCE LEVEL to -20 dBm and note the reference amplitude.

d. Remove the CAL signal to the RF INPUT and apply a -30 dBm, 2 GHz signal from a UHF signal generator to the RF INPUT.

e. Adjust the signal generator level until the 2.0 GHz signal is the same amplitude as the reference, established in part c of this step.

f. Increase the signal generator output until the signal compresses 1 dB (e.g., a -18 dBm signal display reduces to -19 dBm). Signal compression point must not occur before -18 dBm.

g. Use the signal generator as a 1.5 GHz signal source to establish the reference, then use the above procedure to determine the 1 dB compression point at 1.5 GHz. Signal compression must not occur before -22 dBm.

13. Adjustment of the Preselector Offset

a. On the 1st LO and Preselector Driver board, remove Q2070, connect a shorting strap across TP2060 and TP2065, and connect a voltmeter or dc coupled test oscilloscope probe between connector P and ground (see Fig. 4-48).

b. Set the 7L18 FREQUENCY RANGE to Band 6 (12.5 to 24.5 GHz).

c. Adjust the PEAKING control for zero volt between point P and ground.

d. Connect the voltmeter or test scope probe across TP2065 and Pin J. Adjust R2066 for zero volt between TP2065 and Pin J.

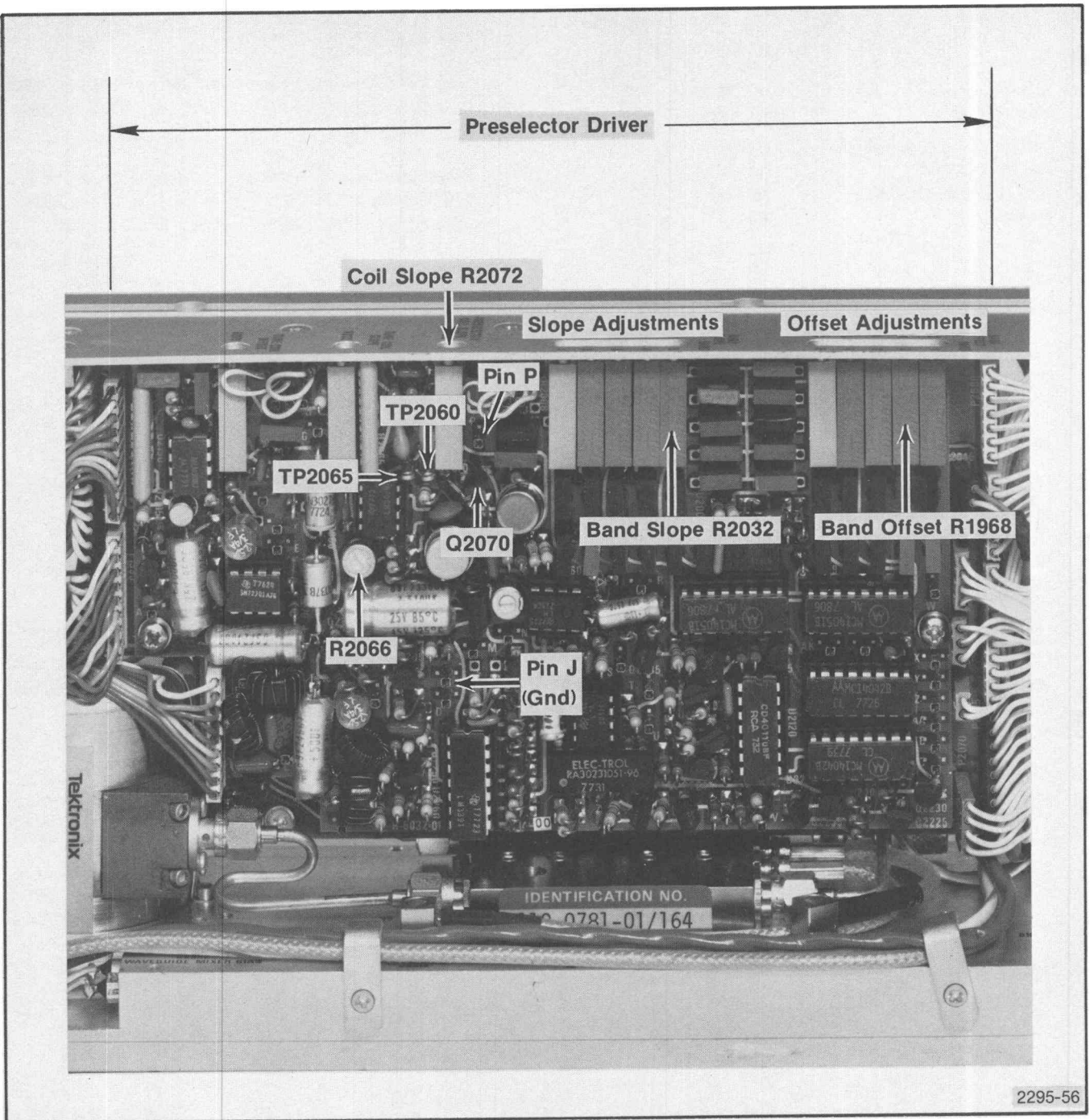

Fig. 4-48. Preselector Driver Adjustment and T.P. Locations.

NOTE

This adjustment will be in the millivolt range; use the appropriate scale.

- e. Remove the shorting strap and replace Q2070.

14. Adjust Preselector Tracking and Flatness

This two part procedure consists of preliminary and final adjustments. In most cases the preliminary adjustments are required only if the YIG preselector is replaced; otherwise, only the final (beginning with part m) adjustments are required.

Preliminary

a. Set the front panel controls as follows:

Vertical Mode	10 dB/DIV
TIME/DIV	AUTO
RESOLUTION BANDWIDTH	AUTO
RF Attenuation	40 dB
FREQ SPAN/DIV	MAX
BAND	5 (9.5—18.0 GHz)

b. Adjust the PEAKING control for +7.5 volts at its center tap (midrange).

c. Set the following Preselector Driver and Vertical Microcomputer Interface adjustments to midrange (see Figs. 4-48 and 4-49).

Band 1 through 5 Offset adjustment—R1962, R1970, R1976, R1980 and R1986 (Fig. 4-48). Band 1 through 5 Slope adjustments—R2008, R2014, R2020, R2026, and

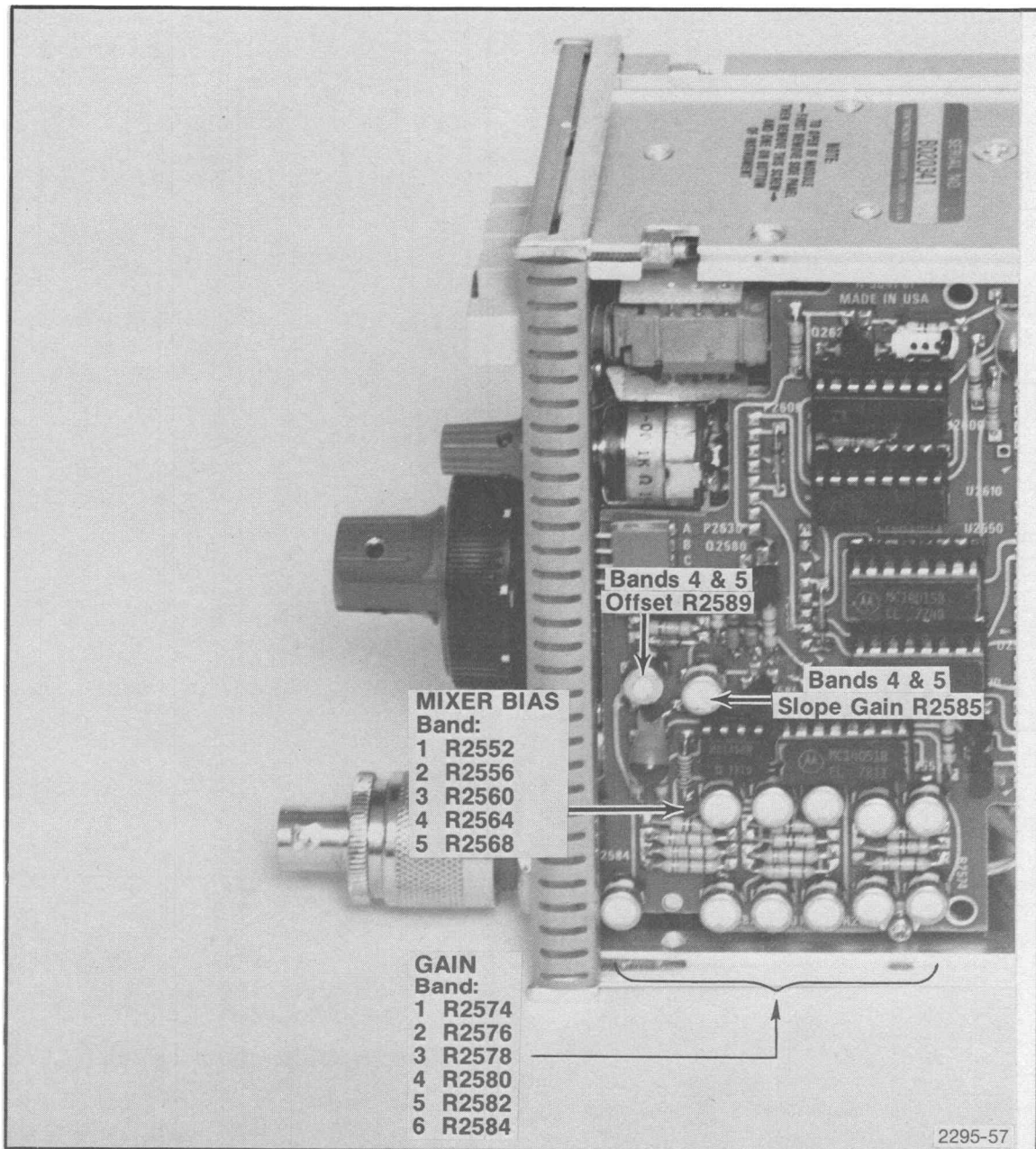

Fig. 4-49. Vertical Microcomputer Interface Adjustment and T.P. Locations.

R2032 (Fig. 4-48). Band 1 through 6 Gain adjustments—R2574, R2576, R2578, R2580, R2582, and R2584 (Fig. 4-49). Mixer Bias adjustments—R2560 and R2568 (see Fig. 4-49).

d. Set the following adjustments fully counterclockwise (see Fig. 4-49):

Band 1, 2, and 4 mixer Bias—R2552, R2556, and R2564.

e. Set the RF Attenuator to 10 dB. Connect the output of a Comb Generator (e.g., 067-0885-00) to the RF INPUT. (Ensure that the RF Attenuator is set for 40 dB of attenuation.) The output pulses of the Comb Generator should appear as a comb of 500 MHz markers on the display.

f. Adjust Preselector Coil Slope R2072 (see Fig. 4-48) to center the comb of markers on the display.

g. Change BAND selector to 2 (2.5 to 4.5 GHz) and adjust Band Offset R1968 (see Fig. 4-48) to center the comb envelope on the display.

NOTE

If an adjustment range is limited to the extent that the comb envelope cannot be centered, readjust Coil Slope R2072 and repeat the adjustment step. If this procedure is unsuccessful, it may be necessary to add correction resistors to change the adjustment range of the Slope and Offset adjustments for Bands 1 through 5. Suggested correction values for each adjustment are listed in Table 4-9. If an adjustment range is limited in the clockwise direction, add a series resistor to increase the voltage. If the range is limited in the counterclockwise direction, add a parallel resistor. The resistance values listed in Table 4-9 were chosen to provide for an adjustment range increase of 50% or 100%. If some other percentage of adjustment range increase is desired, add a resistor of the appropriate value.

The Preselector Driver board has two rows of pads (see Fig. 4-50) that are to be used when installing correction resistors. The row of pads labeled SER, for series, have shorting straps located on the back side of the board. These straps must be removed before the resistor is installed. The row of pads labeled PAR, for parallel, does not have shorting straps.

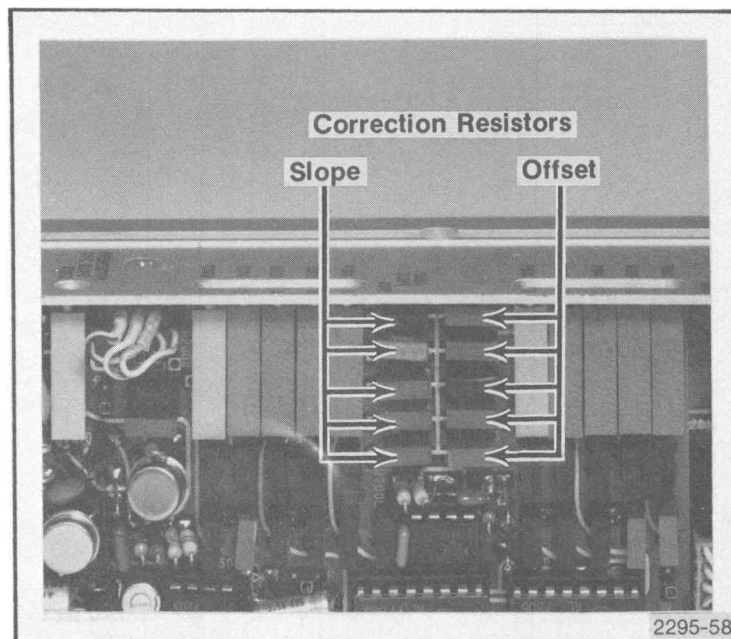

Fig. 4-50. Location of Preselector Driver Slope and Offset Correction Resistors Listed in Table 4-7.

Table 4-9

Control	Fixed Resistor	Series cw Limited		Parallel ccw Limited	
		50%	100%	50%	100%
Band 1 Offset	R1992	1.291K	2.32K	330K	162K
Band 2 Offset	R1994	931	1.87K	249K	111K
Band 3 Offset	R1996	590	1.15K	150K	72.3K
Band 4 Offset	R1998	335.6	650.4	90K	42K
Band 5 Offset	R2000	250	455	61.73K	27.4K
Band 1 Slope	R2038	3.04K	6.04K	731.3K	400K
Band 2 Slope	R2040	3.04K	6.04K	731.3K	400K
Band 3 Slope	R2042	1.56K	3.04K	400K	187K
Band 4 Slope	R2044	1K	2K	277.8K	121K
Band 5 Slope	R2046	650.4	1.24K	162K	72.3K

NOTE

Part numbers for resistors with the suggested values are listed in Table 4-10. If a resistor is used that is not listed, observe the tolerance and temperature requirements for the suggested resistor.

Table 4-10

Tektronix Part Numbers and Tolerance Values for Corrective Resistors

Value	Part Number
250	0.1% T9 321-0928-07
335.6	0.1% T9 321-0814-07
455	0.1% T9 321-0812-07
590	1% T9 321-0171-09
650.4	0.25% T9 321-0650-00
931	1% T9 321-0190-09
1.00K	0.1% T9 321-0193-07
1.15K	0.25% T9 321-0199-06
1.24K	1% T9 321-0202-09
1.291K	0.1% T9 321-0915-07
1.56K	1% T9 321-1211-09
1.87K	1% T9 321-0219-09
2.0K	1% T9 321-0222-09
2.32K	1% T9 321-0228-09
3.04K	0.1% T9 321-0666-07
6.04K	1% T9 321-0268-09
27.4K	1% T9 321-0331-09
42K	0.25% T9 321-0820-06
61.73K	0.25% T9 321-1622-06
72.3K	0.25% T9 321-1642-06
90K	0.1% T9 321-0993-07

Table 4-10 (cont)

Value	Part Number
111K	0.1% T9 321-1389-07
121K	1% T9 321-0393-09
150K	1% T9 321-0402-09
162K	1% T9 321-0405-09
187K	0.25% T9 321-0701-00
249K	1% T9 321-0423-09
277.8K	0.25% T9 321-1625-06
330K	0.1% T9 321-0856-07
400K	0.25% T9 321-0781-06
731.3K	0.25% T9 321-1627-06

h. Set Band selector to 5 and adjust Band 5 Slope R2032 to equalize the amplitude of the high and low segments of the comb. Select that combination of Band 5 Slope and Band 5 Offset adjustments to produce a maximum peak value for the comb line display. If the Slope is adjusted properly, adjusting the Offset should affect the amplitude and direction of all comb markers equally.

i. Adjust Band 5 Bias R2568 (see Fig. 4-49) for overall flatness of the comb display. Use the RF Attenuator, if needed, to avoid over-driving the preselector.

j. Switch to Band 4 (6.5 to 12.5 GHz) and adjust Band 4 Offset R1980 (Fig. 4-48) and Bias R2564 (Fig. 4-49) for maximum comb amplitude and flatness. Use the same procedure as that described for Band 5.

k. Using the foregoing procedure, adjust Bands 3, 2, and 1 Offset, Slope, and Bias for the best tracking and flatness on each band.

l. Disconnect the Comb Generator from the RF INPUT and return the RF Attenuator setting to 10 dB.

FINAL

m. Apply a -30 dBm signal from a leveled sweep generator with an output power meter to the 7L18 input mixer. If the generator output level is too high (e.g., 0 dBm minimum), use an external attenuator or add appropriate attenuation with the 7L18 RF Attenuator.

NOTE

If an external attenuator is used, ensure that its frequency specifications exceed 18 GHz. The PEAKING control should still be centered (+7.5 V at its center terminal) as directed in part b.

n. Set the 7L18 and signal generator controls as follows:

7L18

FREQ SPAN/DIV	MAX
RESOLUTION BANDWIDTH	AUTO
TIME/DIV	AUTO
BAND	9.5 to 18 GHz (5)
RF Attenuation	10 dB above setting for part m of this step
REFERENCE LEVEL	-20 dBm
Display Mode	2 dB/DIV
Digital Storage	DISPLAY A/DISPLAY B

Sweep Generator

Trigger	Int or Single
Time	100 s or slower
Sweep Function	Auto
Start Marker	9.5 GHz
Stop Marker	18.0 GHz
Power Level	0 dBm or lower

o. Position adjustments R2047 (Preselector Peaking) and R2589 (Band Offset) to midrange (Figs. 4-48 and 4-49). Set the amplitude of the sweep generator display to midscreen with the REF VAR control. Observe the stored display after one full sweep.

p. Adjust R2043 (Band 5 Slope) R1986 (Offset), and R2568 (Mixer Bias), for best overall flatness. If flatness rolls off at the high end, adjust the overall Slope Gain with R2585 (Fig. 4-49). R2585 also affects Band 4 flatness. Slope adjustment R2032 (Fig. 4-48) affects the gain slope or the high end of the frequency range. Mixer bias should be adjusted for best sensitivity at the high end and Offset adjustment R1968 should shift the overall response about the center of the span.

q. Adjust preselector peaking with R2042 (see Fig. 4-48) for maximum response at the high end of Band 5. This calibrates the position of the front panel PEAKING control at midrange.

r. Change the sweep generator span to sweep from 6.5 to 12.5 GHz and the 7L18 to Band 4 (6.5 to 12.5 GHz). Note the flatness.

s. Adjust Band 4 Slope R2026, Offset R1980 (Fig. 4-48), and Mixer Bias R2564 (Fig. 4-49), for the best overall flatness using the procedure outlined in p of this step. Since R2585 and R2589 affect flatness for both Bands 4 and 5, it may be necessary to set these for the best compromise between the two.

t. Set the 7L18 Band to 3 and the sweep generator to sweep from 3.5 to 7.5 GHz. Note the flatness.

u. Adjust Band 3 Slope R2020, Offset R2026, and Mixer Bias R2560, for best overall flatness.

v. Change the 7L18 frequency range to Band 2 and the sweep generator to sweep from 2.5 to 4.5 GHz. Note the flatness.

w. Adjust Band 2 Slope R2014, Offset R1968, and Mixer Bias R2556 (Figs. 4-48 and 4-49), for best overall flatness.

x. Set the 7L18 frequency range to Band 1 and change the sweep generator frequency to sweep from 1.5 to 3.5 GHz. Check the flatness.

NOTE

It may be necessary to change sweep generators to cover the frequency span of Band 1.

y. Adjust Band 1 Slope R2008, Offset R1962, and Mixer Bias R2582, for best flatness.

NOTE

Flatness is not specified but is typically ±1 dB worse than the frequency response. Frequency response is determined for each band with the PEAKING control adjusted to maximize the response. Frequency response is ±5 dB from 1.5 to 18.0 GHz.

15. Calibrate the Gain for Coaxial Bands 1 through 5

NOTE

The mean value of the flatness response for all bands is set to a -30 dBm, 2.0 GHz reference.

a. Set the front panel controls as follows:

CENTER FREQUENCY	2.0 GHz
BAND Selection	1.5 to 3.5 GHz (1)
Display Mode	2 dB/DIV
RF Attenuation	10 dB
REFERENCE LEVEL	-20 dBm
FREQ SPAN/DIV	MAX
RESOLUTION BANDWIDTH	AUTO
TIME/DIV	AUTO
Digital Storage	Display A/Display B

b. Preset Band 1 Gain R2574 (see Fig. 4-48) approximately 10% above its fully ccw position.

c. Apply a calibrated -30 dBm, 2.0 GHz reference signal to the RF INPUT. Use the 7L18 Calibrator signal if accuracy has been verified; or, measure the output of the sweep generator at 2.0 GHz with an accurate power meter. Measure at the cable end of the output to ensure -30 dBm level into the 7L18 RF INPUT.

d. Adjust the PEAKING control for maximum signal amplitude; then set the signal peak at the -30 dBm graticule reference line with the front panel AMPLITUDE adjustment (five divisions below the reference, top, graticule line with -20 dBm REFERENCE LEVEL).

e. Remove the -30 dBm calibrated source if the Calibrator was used; then apply the output of a power leveled sweep generator to the RF INPUT. Set the frequency to 2.0 GHz and the output to the -30 dBm reference established in part d of this step.

f. Set the 7L18 BAND selector to Band 2 (2.5 to 4.5 GHz), and set the generator for a sweep from 2.5 to 4.5 GHz.

g. Adjust the Band 2 Gain R2576 (see Fig. 4-49) so the mean average level of the display is at the -30 dBm reference.

h. Change the 7L18 BAND selector to Band 3 (3.5 to 7.5 GHz) and the sweep generator for a sweep from 3.5 to 7.5 GHz.

i. Adjust Band 3 Gain R2578 (see Fig. 4-49) so the mean level (arithmetic average between maximum and minimum excursions) of the display is at the -30 dBm reference.

j. Change the BAND selector to Band 4 (6.5 to 12.5 GHz) and the sweep generator for a sweep that covers Band 4.

k. Adjust Band 4 Gain R2580 (Fig. 4-49) so the mean (average) level of the display is at the -30 dBm reference.

l. Set the 7L18 BAND selector to 5 (9.5 to 18.0 GHz) and the sweep generator for a sweep that covers Band 5.

m. Adjust Band 5 Gain R2582 (Fig. 4-49) so the display mean amplitude level is at the -30 dBm reference.

n. Disconnect and remove the test equipment setup.

16. Calibrate the Gain of the Waveguide Bands (6 through 10)

a. Set the 7L18 BAND selector to Band 6 (12.5 to 24.5 GHz), the RF Attenuator at 0 dB, and the REFERENCE LEVEL for -30 dBm. Set FREQ SPAN/DIV to 200 MHz, RESOLUTION BANDWIDTH and TIME/DIV to AUTO.

b. Apply a calibrated -60 dBm, 510 MHz signal from a UHF signal generator, through a dc blocking capacitor (e.g., Tektronix Part No. 015-0021-00) to the EXT MIXER input of the 7L18 (see Fig. 4-51).

NOTE

The baseline of the display will rise when the 510 MHz signal is applied to the EXT MIXER input port.

c. Adjust waveguide band Gain R2584 (see Fig. 4-49) so the display amplitude is at the -30 dBm reference established in step 15.

d. Return the BAND selector to 1 (1.5 to 3.5 GHz); disconnect the signal generator from the MIXER INPUT and reconnect the 50 ohm termination to the EXT MIXER bias port.

This concludes the adjustment part of the Calibration Procedure. After performing any adjustment procedure recheck the 7L18 performance to ensure it is operating within specifications.

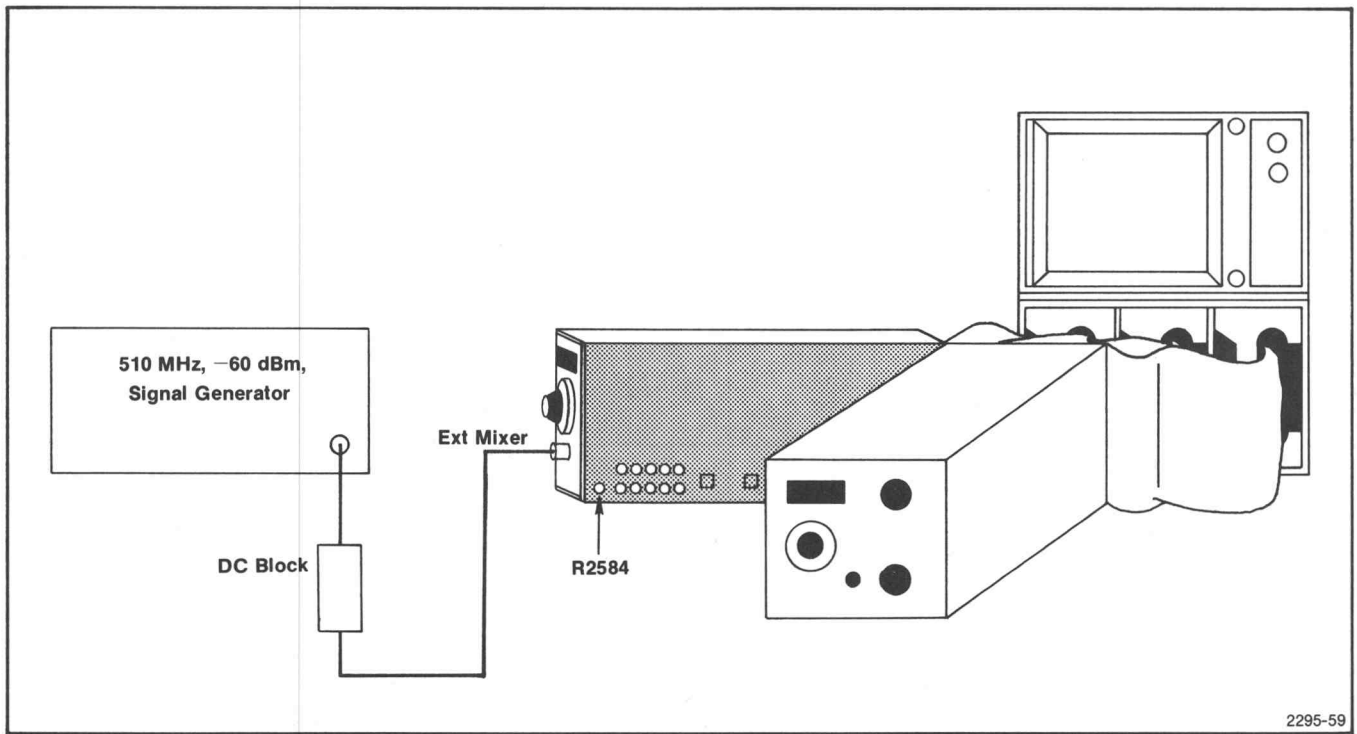

2295-59

Fig. 4-51. Test Setup for Calibrating Gain of the Waveguide Bands.

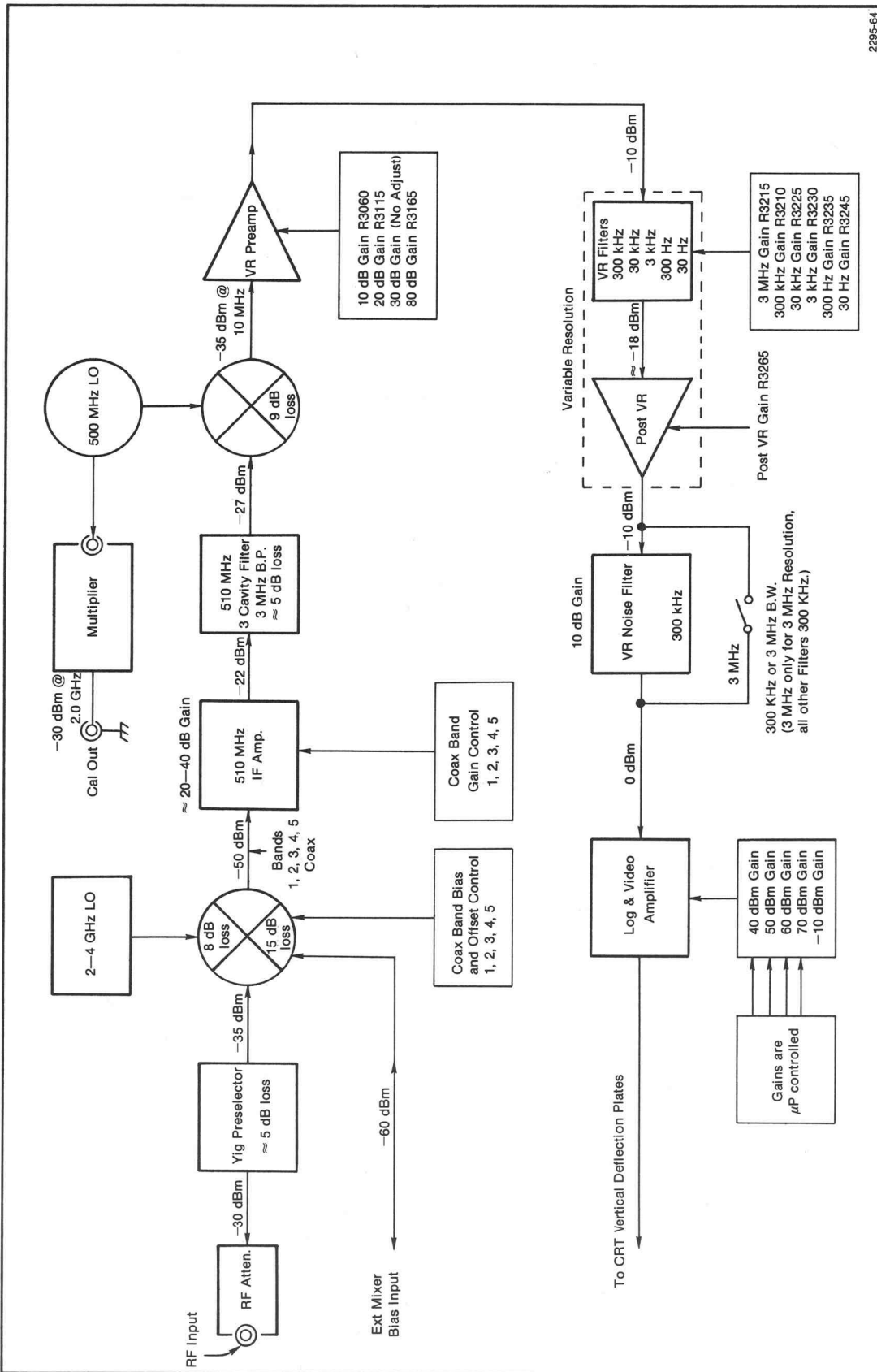

Fig. 4-52. Typical signal levels of the signal path through the 7L18.

REPLACEABLE ELECTRICAL PARTS

PARTS ORDERING INFORMATION

Replacement parts are available from or through your local Tektronix, Inc. Field Office or representative.

Changes to Tektronix instruments are sometimes made to accommodate improved components as they become available, and to give you the benefit of the latest circuit improvements developed in our engineering department. It is therefore important, when ordering parts, to include the following information in your order: Part number, instrument type or number, serial number, and modification number if applicable.

If a part you have ordered has been replaced with a new or improved part, your local Tektronix, Inc. Field Office or representative will contact you concerning any change in part number.

Change information, if any, is located at the rear of this manual.

SPECIAL NOTES AND SYMBOLS

X000 Part first added at this serial number
00X Part removed after this serial number

ITEM NAME

In the Parts List, an Item Name is separated from the description by a colon (:). Because of space limitations, an Item Name may sometimes appear as incomplete. For further Item Name identification, the U.S. Federal Cataloging Handbook H6-1 can be utilized where possible.

ABBREVIATIONS

ACTR	ACTUATOR	PLSTC	PLASTIC
ASSY	ASSEMBLY	QTZ	QUARTZ
CAP	CAPACITOR	RECP	RECEPTACLE
CER	CERAMIC	RES	RESISTOR
CKT	CIRCUIT	RF	RADIO FREQUENCY
COMP	COMPOSITION	SEL	SELECTED
CONN	CONNECTOR	SEMICOND	SEMICONDUCTOR
ELCTLT	ELECTROLYTIC	SENS	SENSITIVE
ELEC	ELECTRICAL	VAR	VARIABLE
INCAND	INCANDESCENT	WW	WIREWOUND
LED	LIGHT EMITTING DIODE	XFMR	TRANSFORMER
NONWIR	NON WIREWOUND	XTAL	CRYSTAL

CROSS INDEX—MFR. CODE NUMBER TO MANUFACTURER

Mfr. Code	Manufacturer	Address	City, State, Zip
00853	SANGAMO ELECTRIC CO., S. CAROLINA DIV.	P O BOX 128	PICKENS, SC 29671
01121	ALLEN-BRADLEY COMPANY	1201 2ND STREET SOUTH	MILWAUKEE, WI 53204
01295	TEXAS INSTRUMENTS, INC., SEMICONDUCTOR GROUP	P O BOX 5012, 13500 N CENTRAL EXPRESSWAY	DALLAS, TX 75222
02111	SPECTROL ELECTRONICS CORPORATION	17070 EAST GALE AVENUE	CITY OF INDUSTRY, CA 91745
02735	RCA CORPORATION, SOLID STATE DIVISION	ROUTE 202	SOMERVILLE, NY 08876
03508	GENERAL ELECTRIC COMPANY, SEMI-CONDUCTOR PRODUCTS DEPARTMENT	ELECTRONICS PARK	SYRACUSE, NY 13201
04222	AVX CERAMICS, DIVISION OF AVX CORP.	P O BOX 867, 19TH AVE. SOUTH	MYRTLE BEACH, SC 29577
04713	MOTOROLA, INC., SEMICONDUCTOR PROD. DIV.	5005 E MCDOWELL RD, PO BOX 20923	PHOENIX, AZ 85036
05828	GENERAL INSTRUMENT CORP ELECTRONIC SYSTEMS DIV.	600 W JOHN ST.	HICKSVILLE LI, NY 11802
07088	KELVIN ELECTRIC COMPANY	5907 NOBLE AVENUE	VAN NUYS, CA 91411
07263	FAIRCHILD SEMICONDUCTOR, A DIV. OF FAIRCHILD CAMERA AND INSTRUMENT CORP.	464 ELLIS STREET	MOUNTAIN VIEW, CA 94042
10389	CHICAGO SWITCH, INC.	2035 WABANSIA AVE.	CHICAGO, IL 60647
12697	CLAROSTAT MFG. CO., INC.	LOWER WASHINGTON STREET	DOVER, NH 03820
12969	UNITRODE CORPORATION	580 PLEASANT STREET	WATERTOWN, MA 02172
14433	ITT SEMICONDUCTORS	3301 ELECTRONICS WAY P O BOX 3049	WEST PALM BEACH, FL 33402
14552	MICRO SEMICONDUCTOR CORP.	2830 E FAIRVIEW ST.	SANTA ANA, CA 92704
14752	ELECTRO CUBE INC.	1710 S. DEL MAR AVE.	SAN GABRIEL, CA 91776
14936	GENERAL INSTRUMENT CORP., SEMICONDUCTOR PRODUCTS GROUP	P.O. BOX 600, 600 W. JOHN ST.	HICKSVILLE, NY 11802
15238	ITT SEMICONDUCTORS, A DIVISION OF INTER NATIONAL TELEPHONE AND TELEGRAPH CORP.	P.O. BOX 168, 500 BROADWAY	LAWRENCE, MA 01841
17856	SILICONIX, INC.	2201 LAURELWOOD DRIVE	SANTA CLARA, CA 95054
18324	SIGNETICS CORP.	811 E. ARQUES	SUNNYVALE, CA 94086
18583	CURTIS INSTRUMENTS, INC.	200 KISCO AVE.	MOUNT KISCO, NY 10549
24355	ANALOG DEVICES INC.	RT 1 INDUSTRIAL PK, P O BOX 280	NORWOOD, MA 02062
24546	CORNING GLASS WORKS, ELECTRONIC COMPONENTS DIVISION	550 HIGH STREET	BRADFORD, PA 16701
27014	NATIONAL SEMICONDUCTOR CORP.	2900 SEMICONDUCTOR DR.	SANTA CLARA, CA 95051
32159	WEST-CAP ARIZONA	2201 E. ELVIRA ROAD	TUCSON, AZ 85706
32997	BOURNS, INC., TRIMPOT PRODUCTS DIV.	1200 COLUMBIA AVE.	RIVERSIDE, CA 92507
34371	HARRIS SEMICONDUCTOR, DIV. OF HARRIS CORPORATION	P. O. BOX 883	MELBOURNE, FL 32901
34630	TYCO FILTERS DIV., INC.	3940 W. MONTECITO	PHOENIX, AZ 85019
50101	GHZ DEVICES, INC.	16 MAPLE ROAD	SOUTH CHELMSFORD, MA 01824
50434	HEWLETT-PACKARD COMPANY	640 PAGE MILL ROAD	PALO ALTO, CA 94304
50579	LITRONIX INC.	19000 HOMESTEAD RD.	CUPERTINO, CA 95014
51642	CENTRE ENGINEERING INC.	2820 E COLLEGE AVENUE	STATE COLLEGE, PA 16801
52769	SPRAGUE GOODMAN ELEC., INC.	134 FULTON AVENUE	GARDEN CITY PARK, NY 11040
53184	XCITON CORPORATION	5 HEMLOCK STREET	LATHAM, NY 12110
55680	NICHICON/AMERICA/CORP.	6435 N PROESEL AVENUE	CHICAGO, IL 60645
56289	SPRAGUE ELECTRIC CO.	87 MARSHALL ST.	NORTH ADAMS, MA 01247
59660	TUSONIX INC.	2155 N FORBES BLVD	TUCSON, AZ 85705
71034	BLILEY ELECTRIC CO.	2545 W. GRANDVIEW BLVD.	ERIE, PA 16512
72136	ELECTRO MOTIVE CORPORATION, SUB OF INTERNATIONAL ELECTRONICS CORPORATION	LAUTER AVE, P O BOX 7600	FLORENCE, SC 29501
72982	ERIE TECHNOLOGICAL PRODUCTS, INC.	644 W. 12TH ST.	ERIE, PA 16512
73138	BECKMAN INSTRUMENTS, INC., HELIPOT DIV.	2500 HARBOR BLVD.	FULLERTON, CA 92634
74970	JOHNSON, E. F., CO.	299 10TH AVE. S. W.	WASECA, MN 56093
75042	TRW ELECTRONIC COMPONENTS, IRC FIXED RESISTORS, PHILADELPHIA DIVISION	401 N. BROAD ST.	PHILADELPHIA, PA 19108
75915	LITTELFUSE, INC.	800 E. NORTHWEST HWY	DES PLAINES, IL 60016
76493	BELL INDUSTRIES, INC., MILLER, J. W., DIV.	19070 REYES AVE., P O BOX 5825	COMPTON, CA 90224
80009	TEKTRONIX, INC.	P O BOX 500	BEAVERTON, OR 97077
80031	ELECTRA-MIDLAND CORP., MEPCO DIV.	22 COLUMBIA ROAD	MORRISTOWN, NJ 07960
90201	MALLORY CAPACITOR CO., DIV. OF P. R. MALLORY AND CO., INC.	3029 E. WASHINGTON STREET P. O. BOX 372	INDIANAPOLIS, IN 46206
91637	DALE ELECTRONICS, INC.	P. O. BOX 609	COLUMBUS, NE 68601
95275	VITRAMON, INC.	P O BOX 544	BRIDGEPORT, CT 06601
95348	GORDOS CORPORATION	250 GLENWOOD AVENUE	BLOOMFIELD, NJ 07003

Replaceable Electrical Parts—7L18 Service

Ckt No.	Tektronix Part No.	Serial/Model No. Eff	Dscont	Name & Description	Mfr Code	Mfr Part Number
A10	119-0790-00			ATTENUATOR ASSY:	80009	119-0790-00
A20	119-0761-00	B010100	B020293	YIG TUNED FLTR:	80009	119-0761-00
A20	119-0761-01	B020294		YIG TUNED FLTR:	80009	119-0761-01
A40	119-0781-01			FIRST CONV ASSY:	80009	119-0781-01
A45	119-0972-02			DIODE ASSY:1ST CONVERTER	80009	119-0972-02
A50	119-0776-00			HYBRID CKT ASSY:	80009	119-0776-00
A60	119-0819-01			OSCILLATOR,RF:W/CAN	80009	119-0819-01
A60A1	670-4785-00			CKT BOARD ASSY:YIG OSCILLATOR	80009	670-4785-00
A100A1	670-4487-00			CKT BOARD ASSY:FRONT PANEL #1	80009	670-4487-00
A100A2	672-0590-00			CKT BOARD ASSY:FRONT PANEL #2	80009	672-0590-00
A100A2A1	670-4492-00			CKT BOARD ASSY:FRONT PANEL #2	80009	670-4492-00
A300	670-4505-00	B010100	B020162	CKT BOARD ASSY:MICROCOMPUTER	80009	670-4505-00
A300	670-4505-01	B020163		CKT BOARD ASSY:MICROCOMPUTER	80009	670-4505-01
A400	670-4470-00			CKT BOARD ASSY:DIGITAL STORAGE	80009	670-4470-00
A450	670-4472-00			CKT BOARD ASSY:CENTER FREQUENCY DVM	80009	670-4472-00
A550	670-4471-00			CKT BOARD ASSY:LOG AMPLIFIER AND VERTICAL	80009	670-4471-00
A940	644-0085-00			LOCK ASSY:HONEYCOMB	80009	644-0085-00
A940A1	670-4475-00	B010100	B020664	CKT BOARD ASSY:REFERENCE OSCILLATOR	80009	670-4475-00
A940A1	670-4475-01	B020665		CKT BOARD ASSY:REFERENCE OSCILLATOR	80009	670-4475-01
A940A2	670-4477-00			CKT BOARD ASSY:MIXER	80009	670-4477-00
A940A3	670-4476-00			CKT BOARD ASSY:PHASE/FREQUENCY DETECTOR	80009	670-4476-00
A940A4	670-4478-00			CKT BOARD ASSY:CONTROLLED OSCILLATOR	80009	670-4478-00
A940A5	670-4481-00			CKT BOARD ASSY:16MHZ FILTER	80009	670-4481-00
A940A6	670-4480-00			CKT BOARD ASSY:STROBE DRIVER	80009	670-4480-00
A940A7A1	670-4479-00			CKT BOARD ASSY:OFFSET OSCILLATOR	80009	670-4479-00
A940A7A2	670-4507-00			CKT BOARD ASSY:OSCILLATOR RESONATOR	80009	670-4507-00
A1170	670-4473-00			CKT BOARD ASSY:PHASE LOCK LOGIC CONTROL	80009	670-4473-00
A1270	670-4483-00			CKT BOARD ASSY:SPAN ATTENUATOR	80009	670-4483-00
A1390	670-4484-00			CKT BOARD ASSY:HORIZONTAL	80009	670-4484-00
A1650	670-4485-00	B010100	B020629	CKT BOARD ASSY:CENTER FREQUENCY READOUT	80009	670-4485-00
A1650	670-4485-01	B020630		CKT BOARD ASSY:CENTER FREQUENCY READOUT	80009	670-4485-01
A1750	670-4486-00			CKT BOARD ASSY:CRT READOUT	80009	670-4486-00
A1962	670-4494-00			CKT BOARD ASSY:YIG DRIVER	80009	670-4494-00
A2316	670-4488-00			CKT BOARD ASSY:REFERENCE SUPPLIES	80009	670-4488-00
A2360	644-0093-00			LOCAL OSC ASSY:500MHZ	80009	644-0093-00
A2360A1	670-4495-00			CKT BOARD ASSY:500MHZ LO	80009	670-4495-00
A2360A2	670-4742-00			CKT BOARD ASSY:SECOND MIXER	80009	670-4742-00
A2500	672-0582-00			CKT BOARD ASSY:DISPLAY MODE	80009	672-0582-00
A2550	670-4503-00			CKT BOARD ASSY:VERT MICROCOMPUTER INTFC	80009	670-4503-00
A2640	670-4499-00			CKT BOARD ASSY:RF FRONT PANEL	80009	670-4499-00
A2690	644-0087-00			IF ASSY:510MHZ	80009	644-0087-00
A2690A1	670-4500-00			CKT BOARD ASSY:510MHZ AMPLIFIER	80009	670-4500-00
A2690A2	670-4501-00			CKT BOARD ASSY:WAVE GUIDE BAND RESONATOR	80009	670-4501-00
A2690A3	670-4502-00			CKT BOARD ASSY:COAX BAND RESONATOR	80009	670-4502-00
A2850	670-4489-00			CKT BOARD ASSY:VERTICAL INTERFACE	80009	670-4489-00
A2860	670-4490-00			CKT BOARD ASSY:CENTER INTERFACE	80009	670-4490-00
A2870	670-4491-00			CKT BOARD ASSY:HORIZONTAL INTERFACE	80009	670-4491-00
A2880	670-4493-00	B010100	B020533	CKT BOARD ASSY:MOTHER	80009	670-4493-00
A2880	670-4493-01	B020534		CKT BOARD ASSY:MOTHER	80009	670-4493-01
A2890	670-4498-00			CKT BOARD ASSY:YIG DRIVER MOTHER	80009	670-4498-00
A3000	644-0463-00			VAR RESOLN MDLE:	80009	644-0463-00
A3000A1	670-4635-00			CKT BOARD ASSY:VR INPUT	80009	670-4635-00
A3000A2	670-4636-00			CKT BOARD ASSY:VR PREAMPLIFIER	80009	670-4636-00
A3000A3	670-4637-00			CKT BOARD ASSY:VR AMPLIFIER	80009	670-4637-00
A3000A4	670-4638-00			CKT BOARD ASSY:300KHZ FILTER	80009	670-4638-00
A3000A5	670-4639-00			CKT BOARD ASSY:POST VR AMPLIFIER	80009	670-4639-00
A3000A6	670-4504-00			CKT BOARD ASSY:VR MOTHER	80009	670-4504-00

Replaceable Electrical Parts—7L18 Service

Ckt No.	Tektronix Part No.	Serial/Model No. Eff	Dscont	Name & Description	Mfr Code	Mfr Part Number
A3400	119-0276-01			FILTER, BANDPASS: 30KHZ	34630	10.0-30-6
A3405	119-0278-01			FILTER, BANDPASS: 3KHZ	34630	10.0-3.0
A3410	119-0780-00			FILTER, BANDPASS: 300HZ	80009	119-0780-00
A3415	119-0779-00			FILTER, BANDPASS: 30HZ	80009	119-0779-00
A3420	670-4474-00			CKT BOARD ASSY: VR NOISE FILTER	80009	670-4474-00
A4508	670-4508-00			CKT BOARD ASSY: STORAGE INTERFACE	80009	670-4508-00
C50	290-0309-00			CAP., FXD, ELCTLT: 100UF, 20%, 25V	56289	109D107X0025F2
C52	290-0309-00			CAP., FXD, ELCTLT: 100UF, 20%, 25V	56289	109D107X0025F2
C90	290-0513-00			CAP., FXD, ELCTLT: 510UF, +75-10%, 25V	56289	109D575
C92	290-0513-00			CAP., FXD, ELCTLT: 510UF, +75-10%, 25V	56289	109D575
C100	290-0531-00			CAP., FXD, ELCTLT: 100UF, 20%, 10V	90201	TDC107M010WLC
C102	290-0531-00			CAP., FXD, ELCTLT: 100UF, 20%, 10V	90201	TDC107M010WLC
C104	290-0535-01			CAP., FXD, ELCTLT: 33UF, 20%, 10V	56289	196D336X0010KA1
C158	283-0156-00			CAP., FXD, CER DI: 1000PF, +100-0%, 200V	72982	8111A208Z5U0102Z
C160	283-0058-00			CAP., FXD, CER DI: 0.027UF, 10%, 100V	72982	8131N147X7R0273K
C172	290-0536-00			CAP., FXD, ELCTLT: 10UF, 20%, 25V	90201	TDC106M025FL
C174	290-0536-00			CAP., FXD, ELCTLT: 10UF, 20%, 25V	90201	TDC106M025FL
C182	283-0058-00			CAP., FXD, CER DI: 0.027UF, 10%, 100V	72982	8131N147X7R0273K
C185	283-0150-00			CAP., FXD, CER DI: 650PF, 5%, 200V	59660	835-515B651J
C200	290-0534-00			CAP., FXD, ELCTLT: 1UF, 20%, 35V	56289	196D105X0035HA1
C202	290-0574-00			CAP., FXD, ELCTLT: 47UF, 10%, 20V	90201	TDC476K020CL
C204	290-0574-00			CAP., FXD, ELCTLT: 47UF, 10%, 20V	90201	TDC476K020CL
C205	290-0534-00			CAP., FXD, ELCTLT: 1UF, 20%, 35V	56289	196D105X0035HA1
C208	290-0574-00			CAP., FXD, ELCTLT: 47UF, 10%, 20V	90201	TDC476K020CL
C210	290-0534-00			CAP., FXD, ELCTLT: 1UF, 20%, 35V	56289	196D105X0035HA1
C224	283-0000-00			CAP., FXD, CER DI: 0.001UF, +100-0%, 500V	59660	831-519-Z5U-102P
C226	290-0534-00			CAP., FXD, ELCTLT: 1UF, 20%, 35V	56289	196D105X0035HA1
C230	290-0534-00			CAP., FXD, ELCTLT: 1UF, 20%, 35V	56289	196D105X0035HA1
C242	283-0150-00	B010100	B010149	CAP., FXD, CER DI: 650PF, 5%, 200V	59660	835-515B651J
C242	283-0088-00	B010150		CAP., FXD, CER DI: 1100PF, 5%, 500V	56289	20C285
C246	290-0536-00			CAP., FXD, ELCTLT: 10UF, 20%, 25V	90201	TDC106M025FL
C248	290-0536-00			CAP., FXD, ELCTLT: 10UF, 20%, 25V	90201	TDC106M025FL
C250	290-0536-00			CAP., FXD, ELCTLT: 10UF, 20%, 25V	90201	TDC106M025FL
C252	290-0536-00			CAP., FXD, ELCTLT: 10UF, 20%, 25V	90201	TDC106M025FL
C254	283-0198-00			CAP., FXD, CER DI: 0.22UF, 20%, 50V	72982	8121N083Z5U0224M
C256	283-0330-00			CAP., FXD, CER DI: 100PF, 5%, 50V	51642	150-050-NP0-101J
C258	283-0198-00			CAP., FXD, CER DI: 0.22UF, 20%, 50V	72982	8121N083Z5U0224M
C260	283-0000-00			CAP., FXD, CER DI: 0.001UF, +100-0%, 500V	59660	831-519-Z5U-102P
C262	283-0000-00			CAP., FXD, CER DI: 0.001UF, +100-0%, 500V	59660	831-519-Z5U-102P
C312	290-0718-00			CAP., FXD, ELCTLT: 22UF, 20%, 35V	56289	196D226X0035PE4
C331	283-0177-00			CAP., FXD, CER DI: 1UF, +80-20%, 25V	56289	273C5
C333	290-0534-00			CAP., FXD, ELCTLT: 1UF, 20%, 35V	56289	196D105X0035HA1
C335	283-0603-00			CAP., FXD, MICA D: 113PF, 2%, 300V	00853	D153F1130G0
C337	283-0631-00			CAP., FXD, MICA D: 95PF, 1%, 100V	00853	D151E950F0
C351	283-0212-00			CAP., FXD, CER DI: 2UF, 20%, 50V	72982	8141N064Z5U205M
C375	290-0309-00	B010100	B020299	CAP., FXD, ELCTLT: 100UF, 20%, 25V	56289	109D107X0025F2
C375	290-0747-00	B020300		CAP., FXD, ELCTLT: 100UF, +50-10%, 25V	56289	500D148
C377	290-0534-00			CAP., FXD, ELCTLT: 1UF, 20%, 35V	56289	196D105X0035HA1
C456	281-0523-00			CAP., FXD, CER DI: 100PF, +/-20PF, 500V	72982	301-000U2M0101M
C466	281-0523-00			CAP., FXD, CER DI: 100PF, +/-20PF, 500V	72982	301-000U2M0101M
C472	285-0894-00			CAP., FXD, PLSTC: 5UF, 5%, 50V	56289	LP68A1A505J
C476	281-0508-00			CAP., FXD, CER DI: 12PF, +/-0.6PF, 500V	59660	301-000C0G0120J
C478	283-0670-00			CAP., FXD, MICA D: 375PF, 1%, 500V	00853	D155F3750F0
C480	281-0523-00			CAP., FXD, CER DI: 100PF, +/-20PF, 500V	72982	301-000U2M0101M
C488	283-0204-00			CAP., FXD, CER DI: 0.01UF, 20%, 50V	72982	8121N061Z5U0103M
C490	290-0158-00			CAP., FXD, ELCTLT: 50UF, +75-15%, 25V	56289	109D506C7025F2
C492	290-0574-00			CAP., FXD, ELCTLT: 47UF, 10%, 20V	90201	TDC476K020CL

Ckt No.	Tektronix Part No.	Serial/Model No. Eff	Dscont	Name & Description	Mfr Code	Mfr Part Number
C494	290-0158-00			CAP., FXD, ELCTLT: 50UF, +75-15%, 25V	56289	109D506C7025F2
C496	290-0158-00			CAP., FXD, ELCTLT: 50UF, +75-15%, 25V	56289	109D506C7025F2
C498	290-0574-00			CAP., FXD, ELCTLT: 47UF, 10%, 20V	90201	TDC476K020CL
C500	290-0527-00			CAP., FXD, ELCTLT: 15UF, 20%, 20V	90201	TDC156M020FL
C511	283-0107-00			CAP., FXD, CER DI: 51PF, 5%, 200V	72982	8121B232C0G0510J
C520	281-0523-00			CAP., FXD, CER DI: 100PF, +/-20PF, 500V	72982	301-000U2M0101M
C526	283-0204-00			CAP., FXD, CER DI: 0.01UF, 20%, 50V	72982	8121N061Z5U0103M
C527	283-0177-00			CAP., FXD, CER DI: 1UF, +80-20%, 25V	56289	273C5
C532	290-0527-00			CAP., FXD, ELCTLT: 15UF, 20%, 20V	90201	TDC156M020FL
C534	283-0198-00			CAP., FXD, CER DI: 0.022UF, 20%, 50V	72982	8121N083Z5U0224M
C538	283-0680-00			CAP., FXD, MICA D: 330PF, 1%, 500V	00853	D155E331F0
C544	283-0177-00			CAP., FXD, CER DI: 1UF, +80-20%, 25V	56289	273C5
C548	283-0111-00	B010100	B020249	CAP., FXD, CER DI: 0.1UF, 20%, 50V	72982	8121-N088Z5U104M
C548	283-0203-00	B020250		CAP., FXD, CER DI: 0.47UF, 20%, 50V	72982	8131N075E474M
C554	283-0204-00			CAP., FXD, CER DI: 0.01UF, 20%, 50V	72982	8121N061Z5U0103M
C555	283-0191-00			CAP., FXD, CER DI: 0.022UF, 20%, 50V	72982	8121N075Z5U0223M
C556	283-0191-00			CAP., FXD, CER DI: 0.022UF, 20%, 50V	72982	8121N075Z5U0223M
C561	283-0204-00			CAP., FXD, CER DI: 0.01UF, 20%, 50V	72982	8121N061Z5U0103M
C571	283-0191-00			CAP., FXD, CER DI: 0.022UF, 20%, 50V	72982	8121N075Z5U0223M
C573	283-0204-00			CAP., FXD, CER DI: 0.01UF, 20%, 50V	72982	8121N061Z5U0103M
C575	283-0191-00			CAP., FXD, CER DI: 0.022UF, 20%, 50V	72982	8121N075Z5U0223M
C581	283-0204-00			CAP., FXD, CER DI: 0.01UF, 20%, 50V	72982	8121N061Z5U0103M
C583	283-0191-00			CAP., FXD, CER DI: 0.022UF, 20%, 50V	72982	8121N075Z5U0223M
C591	283-0204-00			CAP., FXD, CER DI: 0.01UF, 20%, 50V	72982	8121N061Z5U0103M
C601	283-0204-00			CAP., FXD, CER DI: 0.01UF, 20%, 50V	72982	8121N061Z5U0103M
C603	283-0191-00			CAP., FXD, CER DI: 0.022UF, 20%, 50V	72982	8121N075Z5U0223M
C607	283-0191-00			CAP., FXD, CER DI: 0.022UF, 20%, 50V	72982	8121N075Z5U0223M
C613	283-0204-00			CAP., FXD, CER DI: 0.01UF, 20%, 50V	72982	8121N061Z5U0103M
C617	283-0191-00			CAP., FXD, CER DI: 0.022UF, 20%, 50V	72982	8121N075Z5U0223M
C621	283-0204-00			CAP., FXD, CER DI: 0.01UF, 20%, 50V	72982	8121N061Z5U0103M
C631	283-0204-00			CAP., FXD, CER DI: 0.01UF, 20%, 50V	72982	8121N061Z5U0103M
C633	283-0191-00			CAP., FXD, CER DI: 0.022UF, 20%, 50V	72982	8121N075Z5U0223M
C637	283-0191-00			CAP., FXD, CER DI: 0.022UF, 20%, 50V	72982	8121N075Z5U0223M
C639	283-0111-00			CAP., FXD, CER DI: 0.1UF, 20%, 50V	72982	8121-N088Z5U104M
C641	283-0111-00			CAP., FXD, CER DI: 0.1UF, 20%, 50V	72982	8121-N088Z5U104M
C643	283-0204-00			CAP., FXD, CER DI: 0.01UF, 20%, 50V	72982	8121N061Z5U0103M
C645	283-0111-00			CAP., FXD, CER DI: 0.1UF, 20%, 50V	72982	8121-N088Z5U104M
C647	283-0191-00			CAP., FXD, CER DI: 0.022UF, 20%, 50V	72982	8121N075Z5U0223M
C649	283-0111-00			CAP., FXD, CER DI: 0.1UF, 20%, 50V	72982	8121-N088Z5U104M
C651	283-0204-00			CAP., FXD, CER DI: 0.01UF, 20%, 50V	72982	8121N061Z5U0103M
C653	283-0204-00			CAP., FXD, CER DI: 0.01UF, 20%, 50V	72982	8121N061Z5U0103M
C655	283-0191-00			CAP., FXD, CER DI: 0.022UF, 20%, 50V	72982	8121N075Z5U0223M
C657	283-0204-00			CAP., FXD, CER DI: 0.01UF, 20%, 50V	72982	8121N061Z5U0103M
C667	283-0191-00			CAP., FXD, CER DI: 0.022UF, 20%, 50V	72982	8121N075Z5U0223M
C671	283-0204-00			CAP., FXD, CER DI: 0.01UF, 20%, 50V	72982	8121N061Z5U0103M
C673	283-0204-00			CAP., FXD, CER DI: 0.01UF, 20%, 50V	72982	8121N061Z5U0103M
C675	283-0191-00			CAP., FXD, CER DI: 0.022UF, 20%, 50V	72982	8121N075Z5U0223M
C677	283-0204-00			CAP., FXD, CER DI: 0.01UF, 20%, 50V	72982	8121N061Z5U0103M
C687	283-0191-00			CAP., FXD, CER DI: 0.022UF, 20%, 50V	72982	8121N075Z5U0223M
C691	283-0204-00			CAP., FXD, CER DI: 0.01UF, 20%, 50V	72982	8121N061Z5U0103M
C693	283-0204-00			CAP., FXD, CER DI: 0.01UF, 20%, 50V	72982	8121N061Z5U0103M
C695	283-0191-00			CAP., FXD, CER DI: 0.022UF, 20%, 50V	72982	8121N075Z5U0223M
C697	283-0204-00			CAP., FXD, CER DI: 0.01UF, 20%, 50V	72982	8121N061Z5U0103M
C698	283-0191-00			CAP., FXD, CER DI: 0.022UF, 20%, 50V	72982	8121N075Z5U0223M
C701	283-0204-00			CAP., FXD, CER DI: 0.01UF, 20%, 50V	72982	8121N061Z5U0103M
C703	283-0204-00			CAP., FXD, CER DI: 0.01UF, 20%, 50V	72982	8121N061Z5U0103M
C705	283-0191-00			CAP., FXD, CER DI: 0.022UF, 20%, 50V	72982	8121N075Z5U0223M

Replaceable Electrical Parts—7L18 Service

Ckt No.	Tektronix Part No.	Serial/Model No. Eff	Dscont	Name & Description	Mfr Code	Mfr Part Number
C707	283-0204-00			CAP., FXD, CER DI: 0.01UF, 20%, 50V	72982	8121N061Z5U0103M
C721	283-0204-00			CAP., FXD, CER DI: 0.01UF, 20%, 50V	72982	8121N061Z5U0103M
C723	283-0201-00			CAP., FXD, CER DI: 27PF, 10%, 200V	72982	8101B210X7R0270K
C731	283-0177-00			CAP., FXD, CER DI: 1UF, +80-20%, 25V	56289	273C5
C733	283-0111-00			CAP., FXD, CER DI: 0.1UF, 20%, 50V	72982	8121-N088Z5U104M
C739	283-0177-00			CAP., FXD, CER DI: 1UF, +80-20%, 25V	56289	273C5
C741	283-0000-00			CAP., FXD, CER DI: 0.001UF, +100-0%, 500V	59660	831-519-Z5U-102P
C743	283-0191-00			CAP., FXD, CER DI: 0.022UF, 20%, 50V	72982	8121N075Z5U0223M
C746	283-0177-00			CAP., FXD, CER DI: 1UF, +80-20%, 25V	56289	273C5
C749	283-0177-00			CAP., FXD, CER DI: 1UF, +80-20%, 25V	56289	273C5
C753	283-0191-00			CAP., FXD, CER DI: 0.022UF, 20%, 50V	72982	8121N075Z5U0223M
C761	283-0648-00			CAP., FXD, MICA D: 10PF, 5%, 100V	00853	D151C100D0
C763	283-0728-00			CAP., FXD, MICA D: 120PF, 1%, 500V	00853	D155F121F03
C765	283-0641-00			CAP., FXD, MICA D: 180PF, 1%, 100V	00853	D151E181F0
C767	283-0639-00			CAP., FXD, MICA D: 56PF, 1%, 100V	00853	D151E560F0
C769	283-0599-00			CAP., FXD, MICA D: 98PF, 5%, 500V	00853	D105E980J0
C825	283-0191-00			CAP., FXD, CER DI: 0.022UF, 20%, 50V	72982	8121N075Z5U0223M
C827	283-0177-00			CAP., FXD, CER DI: 1UF, +80-20%, 25V	56289	273C5
C828	283-0647-00			CAP., FXD, MICA D: 70PF, 1%, 100V	00853	D151E700F0
C829	283-0177-00			CAP., FXD, CER DI: 1UF, +80-20%, 25V	56289	273C5
C837	283-0204-00			CAP., FXD, CER DI: 0.01UF, 20%, 50V	72982	8121N061Z5U0103M
C841	283-0000-00			CAP., FXD, CER DI: 0.001UF, +100-0%, 500V	59660	831-519-Z5U-102P
C941	281-0806-00			FILTER, HF EMI: 1750PF, 250VDC	72982	1214-037
C942	283-0191-00			CAP., FXD, CER DI: 0.022UF, 20%, 50V	72982	8121N075Z5U0223M
C944	283-0191-00			CAP., FXD, CER DI: 0.022UF, 20%, 50V	72982	8121N075Z5U0223M
C946	290-0158-00			CAP., FXD, ELCTLT: 50UF, +75-15%, 25V	56289	109D506C7025F2
C948	283-0111-00			CAP., FXD, CER DI: 0.1UF, 20%, 50V	72982	8121-N088Z5U104M
C958	283-0204-00			CAP., FXD, CER DI: 0.01UF, 20%, 50V	72982	8121N061Z5U0103M
C959	283-0204-00			CAP., FXD, CER DI: 0.001UF, 20%, 50V	72982	8121N061Z5U0103M
C960	290-0534-00			CAP., FXD, ELCTLT: 1UF, 20%, 35V	56289	196D105X0035HA1
C961	281-0806-00			FILTER, HF EMI: 1750PF, 250VDC	72982	1214-037
C962	290-0536-00			CAP., FXD, ELCTLT: 10UF, 20%, 25V	90201	TDC106M025FL
C963	281-0806-00			FILTER, HF EMI: 1750PF, 250VDC	72982	1214-037
C964	283-0204-00			CAP., FXD, CER DI: 0.01UF, 20%, 50V	72982	8121N061Z5U0103M
C965	281-0806-00			FILTER, HF EMI: 1750PF, 250VDC	72982	1214-037
C966	283-0204-00			CAP., FXD, CER DI: 0.01UF, 20%, 50V	72982	8121N061Z5U0103M
C967	281-0806-00			FILTER, HF EMI: 1750PF, 250VDC	72982	1214-037
C969	281-0806-00			FILTER, HF EMI: 1750PF, 250VDC	72982	1214-037
C994	283-0114-00			CAP., FXD, CER DI: 0.0015UF, 5%, 200V	72982	805-509B152J
C996	283-0100-00	B010100	B020159X	CAP., FXD, CER DI: 0.0047UF, 10%, 200V	56289	273C3
C1000	290-0534-00			CAP., FXD, ELCTLT: 1UF, 20%, 35V	56289	196D105X0035HA1
C1002	283-0100-00	B010100	B020159	CAP., FXD, CER DI: 0.0047UF, 10%, 200V	56289	273C3
C1002	283-0238-00	B020160		CAP., FXD, CER DI: 0.01UF, 10%, 50V	72982	8121N075X7R0103K
C1003	283-0111-00	XB020160		CAP., FXD, CER DI: 0.1UF, 20%, 50V	72982	8121-N088Z5U104M
C1004	283-0100-00			CAP., FXD, CER DI: 0.0047UF, 10%, 200V	56289	273C3
C1006	283-0204-00			CAP., FXD, CER DI: 0.01UF, 20%, 50V	72982	8121N061Z5U0103M
C1007	290-0574-00			CAP., FXD, ELCTLT: 47UF, 10%, 20V	90201	TDC476K020CL
C1008	283-0204-00			CAP., FXD, CER DI: 0.01UF, 20%, 50V	72982	8121N061Z5U0103M
C1009	290-0574-00			CAP., FXD, ELCTLT: 47UF, 10%, 20V	90201	TDC476K020CL
C1010	283-0204-00			CAP., FXD, CER DI: 0.01UF, 20%, 50V	72982	8121N061Z5U0103M
C1012	283-0198-00	B010100	B010119	CAP., FXD, CER DI: 0.22UF, 20%, 50V	72982	8121N083Z5U0224M
C1012	290-0512-00	B010120		CAP., FXD, ELCTLT: 22UF, 20%, 15V	56289	196D226X0015KA1
C1014	283-0114-00			CAP., FXD, CER DI: 0.0015UF, 5%, 200V	72982	805-509B152J
C1016	283-0114-00			CAP., FXD, CER DI: 0.0015UF, 5%, 200V	72982	805-509B152J
C1018	283-0326-00			CAP., FXD, CER DI: 0.082UF, 10%, 50V	72982	8121N075X7R0823K
C1020	283-0326-00			CAP., FXD, CER DI: 0.082UF, 10%, 50V	72982	8121N075X7R0823K
C1021	281-0806-00			FILTER, HF EMI: 1750PF, 250VDC	72982	1214-037

Ckt No.	Tektronix Part No.	Serial/Model No. Eff	Dscont	Name & Description	Mfr Code	Mfr Part Number
C1022	283-0204-00			CAP., FXD, CER DI:0.01UF, 20%, 50V	72982	8121N061Z5U0103M
C1023	281-0806-00			FILTER, HF EMI:1750PF, 250VDC	72982	1214-037
C1024	283-0159-00			CAP., FXD, CER DI:18PF, 5%, 50V	72982	8111B065C0G0180J
C1025	281-0806-00			FILTER, HF EMI:1750PF, 250VDC	72982	1214-037
C1026	283-0204-00			CAP., FXD, CER DI:0.01UF, 20%, 50V	72982	8121N061Z5U0103M
C1028	283-0198-00	B010100	B010119	CAP., FXD, CER DI:0.22UF, 20%, 50V	72982	8121N083Z5U0224M
C1028	290-0512-00	B010120		CAP., FXD, ELCTLT:22UF, 20%, 15V	56289	196D226X0015KA1
C1030	281-0806-00			FILTER, HF EMI:1750PF, 250VDC	72982	1214-037
C1032	290-0534-00			CAP., FXD, ELCTLT:1UF, 20%, 35V	56289	196D105X0035HA1
C1034	290-0534-00			CAP., FXD, ELCTLT:1UF, 20%, 35V	56289	196D105X0035HA1
C1036	290-0513-00			CAP., FXD, ELCTLT:510UF, +75-10%, 25V	56289	109D575
C1040	281-0562-00			CAP., FXD, CER DI:39PF, 10%, 500V	59660	301-000U2J0390K
C1042	283-0204-00			CAP., FXD, CER DI:0.01UF, 20%, 50V	72982	8121N061Z5U0103M
C1044	283-0204-00			CAP., FXD, CER DI:0.01UF, 20%, 50V	72982	8121N061Z5U0103M
C1049	283-0204-00			CAP., FXD, CER DI:0.01UF, 20%, 50V	72982	8121N061Z5U0103M
C1050	283-0204-00			CAP., FXD, CER DI:0.01UF, 20%, 50V	72982	8121N061Z5U0103M
C1062	283-0080-00			CAP., FXD, CER DI:0.022UF, +80-20%, 25V	56289	19C611
C1064	283-0080-00			CAP., FXD, CER DI:0.022UF, +80-20%, 25V	56289	19C611
C1065	281-0204-00			CAP., VAR, PLSTC:2-22PF, 100V	80031	287C00222MJ02
C1066	281-0519-00			CAP., FXD, CER DI:47PF, +/-4.7PF, 500V	59660	308-000C0G0470K
C1070	281-0504-00			CAP., FXD, CER DI:10PF, +/-1PF, 500V	59660	301-055C0G0100F
C1072	283-0150-00			CAP., FXD, CER DI:650PF, 5%, 200V	59660	835-515B651J
C1080	-----			(FURNISHED AS A UNIT WITH A940A5)		
C1082	-----			(FURNISHED AS A UNIT WITH A940A5)		
C1084	-----			(FURNISHED AS A UNIT WITH A940A5)		
C1085	-----			(FURNISHED AS A UNIT WITH A940A5)		
C1086	-----			(FURNISHED AS A UNIT WITH A940A5)		
C1088	-----			(FURNISHED AS A UNIT WITH A940A5)		
C1090	283-0204-00			CAP., FXD, CER DI:0.01UF, 20%, 50V	72982	8121N061Z5U0103M
C1092	283-0000-00			CAP., FXD, CER DI:0.001UF, +100-0%, 500V	59660	831-519-Z5U-102P
C1094	283-0204-00			CAP., FXD, CER DI:0.01UF, 20%, 50V	72982	8121N061Z5U0103M
C1096	281-0806-00			FILTER, HF EMI:1750PF, 250VDC	72982	1214-037
C1097	290-0727-00			CAP., FXD, ELCTLT:47UF, 20%, 50V	56289	500D307G025EH7
C1098	281-0806-00			FILTER, HF EMI:1750PF, 250VDC	72982	1214-037
C1100	290-0513-00			CAP., FXD, ELCTLT:510UF, +75-10%, 25V	56289	109D575
C1102	283-0203-00			CAP., FXD, CER DI:0.47UF, 20%, 50V	72982	8131N075E474M
C1104	283-0087-00			CAP., FXD, CER DI:300PF, 10%, 1000V	56289	403637
C1110	283-0115-00			CAP., FXD, CER DI:47PF, 5%, 200V	59660	805-519-C0G0470J
C1112	281-0523-00			CAP., FXD, CER DI:100PF, +/-20PF, 500V	72982	301-000U2M0101M
C1122	283-0198-00			CAP., FXD, CER DI:0.22UF, 20%, 50V	72982	8121N083Z5U0224M
C1123	290-0513-00			CAP., FXD, ELCTLT:510UF, +75-10%, 25V	56289	109D575
C1124	281-0806-00			FILTER, HF EMI:1750PF, 250VDC	72982	1214-037
C1126	281-0806-00			FILTER, HF EMI:1750PF, 250VDC	72982	1214-037
C1130	281-0806-00			FILTER, HF EMI:1750PF, 250VDC	72982	1214-037
C1131	281-0806-00			FILTER, HF EMI:1750PF, 250VDC	72982	1214-037
C1132	281-0806-00			FILTER, HF EMI:1750PF, 250VDC	72982	1214-037
C1133	281-0806-00			FILTER, HF EMI:1750PF, 250VDC	72982	1214-037
C1134	281-0806-00			FILTER, HF EMI:1750PF, 250VDC	72982	1214-037
C1135	283-0201-00			CAP., FXD, CER DI:27PF, 10%, 200V	72982	8101B210X7R0270K
C1136	281-0806-00			FILTER, HF EMI:1750PF, 250VDC	72982	1214-037
C1137	281-0806-00			FILTER, HF EMI:1750PF, 250VDC	72982	1214-037
C1138	281-0806-00			FILTER, HF EMI:1750PF, 250VDC	72982	1214-037
C1139	281-0806-00			FILTER, HF EMI:1750PF, 250VDC	72982	1214-037
C1141	283-0201-00			CAP., FXD, CER DI:27PF, 10%, 200V	72982	8101B210X7R0270K
C1142	283-0111-00			CAP., FXD, CER DI:0.1UF, 20%, 50V	72982	8121-N088Z5U104M
C1144	283-0111-00			CAP., FXD, CER DI:0.1UF, 20%, 50V	72982	8121-N088Z5U104M
C1145	283-0177-00			CAP., FXD, CER DI:1UF, +80-20%, 25V	56289	273C5
C1148	290-0391-00			CAP., FXD, ELCTLT:15UF, 10%, 30V	56289	109D156X9030C2

Replaceable Electrical Parts—7L18 Service

Ckt No.	Tektronix Part No.	Serial/Model No. Eff	Dscont	Name & Description	Mfr Code	Mfr Part Number
C1149	-----			(FURNISHED AS A UNIT WITH A940A7A2)		
C1150	283-0204-00			CAP., FXD, CER DI:0.01UF, 20%, 50V	72982	8121N061Z5U0103M
C1151	-----			(FURNISHED AS A UNIT WITH A940A7A2)		
C1152	-----			(FURNISHED AS A UNIT WITH A940A7A2)		
C1153	283-0198-00			CAP., FXD, CER DI:0.22UF, 20%, 50V	72982	8121N083Z5U0224M
C1154	-----			(FURNISHED AS A UNIT WITH A940A7A2)		
C1155	283-0193-00			CAP., FXD, CER DI:510PF, 2%, 100V	72982	8121N130C0G0511G
C1158	283-0177-00			CAP., FXD, CER DI:1UF, +80-20%, 25V	56289	273C5
C1160	290-0513-00			CAP., FXD, ELCTLT:510UF, +75-10%, 25V	56289	109D575
C1164	283-0198-00			CAP., FXD, CER DI:0.22UF, 20%, 50V	72982	8121N083Z5U0224M
C1167	283-0198-00			CAP., FXD, CER DI:0.22UF, 20%, 50V	72982	8121N083Z5U0224M
C1168	283-0198-00			CAP., FXD, CER DI:0.22UF, 20%, 50V	72982	8121N083Z5U0224M
C1169	290-0721-00			CAP., FXD, ELCTLT:100UF, 20%, 20V	56289	196D107X0020TE3
C1173	290-0721-00			CAP., FXD, ELCTLT:100UF, 20%, 20V	56289	196D107X0020TE3
C1177	290-0721-00			CAP., FXD, ELCTLT:100UF, 20%, 20V	56289	196D107X0020TE3
C1179	283-0111-00			CAP., FXD, CER DI:0.1UF, 20%, 50V	72982	8121-N088Z5U104M
C1200	283-0212-00			CAP., FXD, CER DI:2UF, 20%, 50V	72982	8141N064Z5U205M
C1205	283-0070-00			CAP., FXD, CER DI:30PF, 10%, 50V	72982	8121-060C0G0300K
C1207	285-0919-00			CAP., FXD, PLSTC:0.22UF, 10%, 100V	56289	LP66A1B224K002
C1209	285-0809-00			CAP., FXD, PLSTC:1UF, 10%, 50V	56289	LP66A1A105K
C1211	285-0905-00			CAP., FXD, PLSTC:0.33UF, 5%, 50V	56289	LP66A1A334J002
C1225	283-0204-00			CAP., FXD, CER DI:0.01UF, 20%, 50V	72982	8121N061Z5U0103M
C1230	283-0070-00			CAP., FXD, CER DI:30PF, 10%, 50V	72982	8121-060C0G0300K
C1232	290-0536-00			CAP., FXD, ELCTLT:10UF, 20%, 25V	90201	TDC106M025FL
C1233	283-0156-00			CAP., FXD, CER DI:1000PF, +100-0%, 200V	72982	8111A208Z5U0102Z
C1244	283-0191-00			CAP., FXD, CER DI:0.022UF, 20%, 50V	72982	8121N075Z5U0223M
C1247	290-0573-00			CAP., FXD, ELCTLT:2.7UF, 20%, 50V	56289	196D275X0050JA1
C1257	283-0111-00			CAP., FXD, CER DI:0.1UF, 20%, 50V	72982	8121-N088Z5U104M
C1262	283-0177-00			CAP., FXD, CER DI:1UF, +80-20%, 25V	56289	273C5
C1273	290-0804-00			CAP., FXD, ELCTLT:10UF, +50-10%, 25V	55680	25ULA10V-T
C1276	283-0204-00			CAP., FXD, CER DI:0.01UF, 20%, 50V	72982	8121N061Z5U0103M
C1277	290-0513-00			CAP., FXD, ELCTLT:510UF, +75-10%, 25V	56289	109D575
C1281	283-0111-00			CAP., FXD, CER DI:0.1UF, 20%, 50V	72982	8121-N088Z5U104M
C1283	290-0535-00			CAP., FXD, ELCTLT:33UF, 20%, 10V	56289	196D336X0010KA1
C1297	283-0191-00			CAP., FXD, CER DI:0.022UF, 20%, 50V	72982	8121N075Z5U0223M
C1299	283-0010-00			CAP., FXD, CER DI:0.05UF, +100-20%, 50V	56289	273C20
C1300	281-0508-00			CAP., FXD, CER DI:12PF, +/-0.6PF, 500V	59660	301-000C0G0120J
C1301	281-0510-00			CAP., FXD, CER DI:22PF, +/-4.4PF, 500V	59660	301-000C0G0220M
C1341	290-0535-00			CAP., FXD, ELCTLT:33UF, 20%, 10V	56289	196D336X0010KA1
C1347	283-0010-00			CAP., FXD, CER DI:0.05UF, +100-20%, 50V	56289	273C20
C1349	283-0191-00			CAP., FXD, CER DI:0.022UF, 20%, 50V	72982	8121N075Z5U0223M
C1351	285-1076-00			CAP., FXD, PLSTC:0.2UF, 5%, 100V	14752	230B1B204J
C1359	290-0804-00			CAP., FXD, ELCTLT:10UF, +50-10%, 25V	55680	25ULA10V-T
C1363	290-0804-00			CAP., FXD, ELCTLT:10UF, +50-10%, 25V	55680	25ULA10V-T
C1365	283-0177-00			CAP., FXD, CER DI:1UF, +80-20%, 25V	56289	273C5
C1393	283-0177-00			CAP., FXD, CER DI:1UF, +80-20%, 25V	56289	273C5
C1395	283-0177-00			CAP., FXD, CER DI:1UF, +80-20%, 25V	56289	273C5
C1397	283-0177-00			CAP., FXD, CER DI:1UF, +80-20%, 25V	56289	273C5
C1398	281-0572-00			CAP., FXD, CER DI:6.8PF, +/-0.5PF, 500V	59660	301-000C0H0689D
C1410	290-0536-00			CAP., FXD, ELCTLT:10UF, 20%, 25V	90201	TDC106M025FL
C1411	283-0191-00	XB010120		CAP., FXD, CER DI:0.022UF, 20%, 50V	72982	8121N075Z5U0223M
C1423	283-0198-00			CAP., FXD, CER DI:0.22UF, 20%, 50V	72982	8121N083Z5U0224M
C1425	283-0213-00			CAP., FXD, CER DI:300PF, 5%, 100V	72982	8121N130C0G0301J
C1433	283-0177-00			CAP., FXD, CER DI:1UF, +80-20%, 25V	56289	273C5
C1461	281-0523-00			CAP., FXD, CER DI:100PF, +/-20PF, 500V	72982	301-000U2M0101M
C1483	283-0177-00			CAP., FXD, CER DI:1UF, +80-20%, 25V	56289	273C5
C1489	290-0536-00			CAP., FXD, ELCTLT:10UF, 20%, 25V	90201	TDC106M025FL

Ckt No.	Tektronix Part No.	Serial/Model No. Eff	Dscont	Name & Description	Mfr Code	Mfr Part Number	
C1499	283-0198-00			CAP., FXD, CER DI:0.22UF, 20%, 50V	72982	8121N083Z5U0224M	
C1501	283-0177-00			CAP., FXD, CER DI:1UF, +80-20%, 25V	56289	273C5	
C1509	283-0198-00			CAP., FXD, CER DI:0.22UF, 20%, 50V	72982	8121N083Z5U0224M	
C1531	283-0212-00			CAP., FXD, CER DI:2UF, 20%, 50V	72982	8141N064Z5U0205M	
C1541	283-0154-00	XB020163		CAP., FXD, CER DI:22PF, 5%, 50V	72982	8111B061COG220J	
C1543	290-0525-00			CAP., FXD, ELCTLT:4.7UF, 20%, 50V	56289	196D475X0050KA1	
C1545	290-0527-00			CAP., FXD, ELCTLT:15UF, 20%, 20V	90201	TDC156M020FL	
C1547	283-0088-00			CAP., FXD, CER DI:1100PF, 5%, 500V	56289	20C285	
C1549	281-0638-00			CAP., FXD, CER DI:240PF, 5%, 500V	72982	301000Z5D241J	
C1555	285-1052-00			CAP., FXD, PLSTC:10UF, 1%, 100V	14752	230B1B106F	
C1557	285-0596-00		CAP., FXD, PLSTC:0.01UF, 1%, 100V	14752	410B1B103F		
C1559	283-0631-00		CAP., FXD, MICA D:95PF, 1%, 100V	00853	D151E950F0		
C1562	290-0527-00			CAP., FXD, ELCTLT:15UF, 20%, 20V	90201	TDC156M020FL	
C1563	283-0523-00			CAP., FXD, MICA D:500PF, 5%, 500V	72136	CM19C501J	
C1565	281-0536-00			CAP., FXD, CER DI:1000PF, 10%, 500V	72982	301000 X 5P0102K	
C1569	283-0198-00			CAP., FXD, CER DI:0.22UF, 20%, 50V	72982	8121N083Z5U0224M	
C1595	281-0523-00			CAP., FXD, CER DI:100PF, +/-20PF, 500V	72982	301-000U2M0101M	
C1595	281-0504-00			CAP., FXD, CER DI:10PF, +/-1PF, 500V	59660	301-055COG0100F	
C1602	281-0504-00			CAP., FXD, CER DI:10PF, +/-1PF, 500V	59660	301-055COG0100F	
C1605	283-0201-00			CAP., FXD, CER DI:27PF, 10%, 200V	72982	8101B210X7R0270K	
C1632	290-0536-00			CAP., FXD, ELCTLT:10UF, 20%, 25V	90201	TDC106M025FL	
C1635	283-0177-00			CAP., FXD, CER DI:1UF, +80-20%, 25V	56289	273C5	
C1635	283-0177-00			CAP., FXD, CER DI:1UF, +80-20%, 25V	56289	273C5	
C1643	283-0177-00			CAP., FXD, CER DI:1UF, +80-20%, 25V	56289	273C5	
C1645	283-0198-00			CAP., FXD, CER DI:0.22UF, 20%, 50V	72982	8121N083Z5U0224M	
C1647	283-0177-00			CAP., FXD, CER DI:1UF, +80-20%, 25V	56289	273C5	
C1649	290-0535-00			CAP., FXD, ELCTLT:33UF, 20%, 10V	56289	196D336X0010KA1	
C1650	290-0721-00			CAP., FXD, ELCTLT:100UF, 20%, 20V	56289	196D107X0020TE3	
C1652	290-0721-00			CAP., FXD, ELCTLT:100UF, 20%, 20V	56289	196D107X0020TE3	
C1654	290-0721-00			CAP., FXD, ELCTLT:100UF, 20%, 20V	56289	196D107X0020TE3	
C1656	290-0721-00			CAP., FXD, ELCTLT:100UF, 20%, 20V	56289	196D107X0020TE3	
C1658	283-0000-00			CAP., FXD, CER DI:0.001UF, +100-0%, 500V	59660	831-519-Z5U-102P	
C1660	283-0000-00			CAP., FXD, CER DI:0.001UF, +100-0%, 500V	59660	831-519-Z5U-102P	
C1662	283-0000-00			CAP., FXD, CER DI:0.001UF, +100-0%, 500V	59660	831-519-Z5U-102P	
C1664	283-0000-00			CAP., FXD, CER DI:0.001UF, +100-0%, 500V	59660	831-519-Z5U-102P	
C1704	290-0535-00	XB020320		CAP., FXD, ELCTLT:33UF, 20%, 10V	56289	196D336X0010KA1	
C1706	283-0000-00			CAP., FXD, CER DI:0.001UF, +100-0%, 500V	59660	831-519-Z5U-102P	
C1708	283-0000-00			CAP., FXD, CER DI:0.001UF, +100-0%, 500V	59660	831-519-Z5U-102P	
C1721	283-0000-00			CAP., FXD, CER DI:0.001UF, +100-0%, 500V	59660	831-519-Z5U-102P	
C1728	283-0000-00			CAP., FXD, CER DI:0.001UF, +100-0%, 500V	59660	831-519-Z5U-102P	
C1736	283-0000-00			CAP., FXD, CER DI:0.001UF, +100-0%, 500V	59660	831-519-Z5U-102P	
C1741	283-0000-00			CAP., FXD, CER DI:0.001UF, +100-0%, 500V	59660	831-519-Z5U-102P	
C1745	283-0000-00				CAP., FXD, CER DI:0.001UF, +100-0%, 500V	59660	831-519-Z5U-102P
C1752	283-0000-00				CAP., FXD, CER DI:0.001UF, +100-0%, 500V	59660	831-519-Z5U-102P
C1753	283-0000-00				CAP., FXD, CER DI:0.001UF, +100-0%, 500V	59660	831-519-Z5U-102P
C1755	283-0000-00				CAP., FXD, CER DI:0.001UF, +100-0%, 500V	59660	831-519-Z5U-102P
C1756	283-0000-00				CAP., FXD, CER DI:0.001UF, +100-0%, 500V	59660	831-519-Z5U-102P
C1757	283-0000-00			CAP., FXD, CER DI:0.001UF, +100-0%, 500V	59660	831-519-Z5U-102P	
C1781	283-0330-00			CAP., FXD, CER DI:100PF, 5%, 50V	51642	150-050-NP0-101J	
C2005	283-0191-00			CAP., FXD, CER DI:0.022UF, 20%, 50V	72982	8121N075Z5U0223M	
C2007	283-0010-00			CAP., FXD, CER DI:0.05UF, +100-20%, 50V	56289	273C20	
C2063	283-0000-00			CAP., FXD, CER DI:0.001UF, +100-0%, 500V	59660	831-519-Z5U-102P	
C2065	283-0000-00			CAP., FXD, CER DI:0.001UF, +100-0%, 500V	59660	831-519-Z5U-102P	
C2067	283-0070-00			CAP., FXD, CER DI:30PF, 10%, 50V	72982	8121-060COG0300K	
C2069	283-0150-00			CAP., FXD, CER DI:650PF, 5%, 200V	59660	835-515B651J	
C2070	283-0191-00			CAP., FXD, CER DI:0.022UF, 20%, 50V	72982	8121N075Z5U0223M	
C2071	283-0198-00			CAP., FXD, CER DI:0.22UF, 20%, 50V	72982	8121N083Z5U0224M	

Replaceable Electrical Parts—7L18 Service

Ckt No.	Tektronix Part No.	Serial/Model No. Eff	Dscont	Name & Description	Mfr Code	Mfr Part Number
C2101	290-0513-00			CAP.,FXD,ELCTLT:510UF,+75-10%,25V	56289	109D575
C2145	283-0111-00			CAP.,FXD,CER DI:0.1UF,20%,50V	72982	8121-N088Z5U104M
C2153	281-0605-00			CAP.,FXD,CER DI:200PF,10%,500V	04222	7001-1375
C2163	283-0191-00			CAP.,FXD,CER DI:0.022UF,20%,50V	72982	8121N075Z5U0223M
C2165	283-0010-00			CAP.,FXD,CER DI:0.05UF,+100-20%,50V	56289	273C20
C2191	283-0330-00			CAP.,FXD,CER DI:100PF,5%,50V	51642	150-050-NP0-101J
C2198	283-0191-00			CAP.,FXD,CER DI:0.022UF,20%,50V	72982	8121N075Z5U0223M
C2215	290-0650-00			CAP.,FXD,ELCTLT:1000UF,20%,10V	56289	109D108X0010T2
C2271	283-0077-00			CAP.,FXD,CER DI:330PF,5%,500V	59660	831-500B331J
C2280	290-0309-00			CAP.,FXD,ELCTLT:100UF,20%,25V	56289	109D107X0025F2
C2281	290-0340-00			CAP.,FXD,ELCTLT:10UF,10%,50V	56289	109D106X9050C2
C2305	290-0158-00			CAP.,FXD,ELCTLT:50UF,+75-15%,25V	56289	109D506C7025F2
C2307	283-0177-00			CAP.,FXD,CER DI:1UF,+80-20%,25V	56289	273C5
C2311	290-0158-00			CAP.,FXD,ELCTLT:50UF,+75-15%,25V	56289	109D506C7025F2
C2313	283-0177-00			CAP.,FXD,CER DI:1UF,+80-20%,25V	56289	273C5
C2315	283-0177-00			CAP.,FXD,CER DI:1UF,+80-20%,25V	56289	273C5
C2321	290-0718-00			CAP.,FXD,ELCTLT:22UF,20%,35V	56289	196D226X0035PE4
C2322	290-0718-00			CAP.,FXD,ELCTLT:22UF,20%,35V	56289	196D226X0035PE4
C2325	283-0330-00			CAP.,FXD,CER DI:100PF,5%,50V	51642	150-050-NP0-101J
C2330	283-0204-00			CAP.,FXD,CER DI:0.01UF,20%,50V	72982	8121N061Z5U0103M
C2339	290-0309-00	B010100	B010105	CAP.,FXD,ELCTLT:100UF,20%,25V	56289	109D107X0025F2
C2339	290-0721-00	B010106		CAP.,FXD,ELCTLT:100UF,20%,20V	56289	196D107X0020TE3
C2345	283-0330-00			CAP.,FXD,CER DI:100PF,5%,50V	51642	150-050-NP0-101J
C2350	283-0204-00			CAP.,FXD,CER DI:0.01UF,20%,50V	72982	8121N061Z5U0103M
C2355	283-0111-00			CAP.,FXD,CER DI:0.1UF,20%,50V	72982	8121-N088Z5U104M
C2360	281-0806-00			FILTER,HF EMI:1750PF,250VDC	72982	1214-037
C2361	283-0111-00			CAP.,FXD,CER DI:0.1UF,20%,50V	72982	8121-N088Z5U104M
C2362	283-0111-00			CAP.,FXD,CER DI:0.1UF,20%,50V	72982	8121-N088Z5U104M
C2363	283-0111-00			CAP.,FXD,CER DI:0.1UF,20%,50V	72982	8121-N088Z5U104M
C2364	281-0806-00			FILTER,HF EMI:1750PF,250VDC	72982	1214-037
C2365	283-0111-00			CAP.,FXD,CER DI:0.1UF,20%,50V	72982	8121-N088Z5U104M
C2367	283-0156-00			CAP.,FXD,CER DI:1000PF,+100-0%,200V	72982	8111A208Z5U0102Z
C2369	283-0139-00			CAP.,FXD,CER DI:150PF,20%,50V	51642	W100-050-X5F151M
C2371	283-0238-00			CAP.,FXD,CER DI:0.01UF,10%,50V	72982	8121N075X7R0103K
C2372	290-0513-00			CAP.,FXD,ELCTLT:510UF,+75-10%,25V	56289	109D575
C2375	283-0637-00			CAP.,FXD,MICA D:20PF,2.5%,100V	00853	D151E200D0
C2377	283-0185-00			CAP.,FXD,CER DI:2.5PF,5%,50V	72982	8101B057C0K0295B
C2379	281-0202-00			CAP.,VAR,PLSTC:1.5-5.5PF,100V	80031	2807C1R406MM02F
C2380	290-0309-00			CAP.,FXD,ELCTLT:100UF,20%,25V	56289	109D107X0025F2
C2381	283-0156-00			CAP.,FXD,CER DI:1000PF,+100-0%,200V	72982	8111A208Z5U0102Z
C2383	283-0156-00			CAP.,FXD,CER DI:1000PF,+100-0%,200V	72982	8111A208Z5U0102Z
C2387	281-0185-00			CAP.,VAR,PLSTC:2-18PF,250V	80031	2808D00218MH02F0
C2391	283-0156-00			CAP.,FXD,CER DI:1000PF,+100-0%,200V	72982	8111A208Z5U0102Z
C2393	283-0156-00			CAP.,FXD,CER DI:1000PF,+100-0%,200V	72982	8111A208Z5U0102Z
C2397	281-0178-00			CAP.,VAR,PLSTC:1-3.5PF,500V	80031	2805D013R5BH02F0
C2399	283-0200-00			CAP.,FXD,CER DI:10PF,10%,50V	51642	RB055-050Y5R100K
C2403	283-0156-00			CAP.,FXD,CER DI:1000PF,+100-0%,200V	72982	8111A208Z5U0102Z
C2407	283-0139-00			CAP.,FXD,CER DI:150PF,20%,50V	51642	W100-050-X5F151M
C2409	283-0139-00			CAP.,FXD,CER DI:150PF,20%,50V	51642	W100-050-X5F151M
C2411	281-0182-00			CAP.,VAR,PLSTC:1.8-10PF,500V	80031	2805D1R810BH02F0
C2413	283-0156-00			CAP.,FXD,CER DI:1000PF,+100-0%,200V	72982	8111A208Z5U0102Z
C2415	283-0111-00			CAP.,FXD,CER DI:0.1UF,20%,50V	72982	8121-N088Z5U104M
C2417	283-0156-00			CAP.,FXD,CER DI:1000PF,+100-0%,200V	72982	8111A208Z5U0102Z
C2421	283-0111-00			CAP.,FXD,CER DI:0.1UF,20%,50V	72982	8121-N088Z5U104M
C2423	283-0111-00			CAP.,FXD,CER DI:0.1UF,20%,50V	72982	8121-N088Z5U104M
C2425	283-0156-00			CAP.,FXD,CER DI:1000PF,+100-0%,200V	72982	8111A208Z5U0102Z
C2427	283-0156-00			CAP.,FXD,CER DI:1000PF,+100-0%,200V	72982	8111A208Z5U0102Z

Ckt No.	Tektronix Part No.	Serial/Model No. Eff	Dscont	Name & Description	Mfr Code	Mfr Part Number
C2429	283-0200-00			CAP., FXD, CER DI:10PF, 10%, 50V	51642	RB055-050Y5R100K
C2431	281-0185-00			CAP., VAR, PLSTC: 2-18PF, 250V	80031	2808D00218MH02FO
C2433	283-0111-00			CAP., FXD, CER DI:0.1UF, 20%, 50V	72982	8121-N088Z5U104M
C2435	283-0156-00			CAP., FXD, CER DI:1000PF, +100-0%, 200V	72982	8111A208Z5U0102Z
C2441	283-0111-00			CAP., FXD, CER DI:0.1UF, 20%, 50V	72982	8121-N088Z5U104M
C2443	283-0156-00			CAP., FXD, CER DI:1000PF, +100-0%, 200V	72982	8111A208Z5U0102Z
C2445	283-0111-00			CAP., FXD, CER DI:0.1UF, 20%, 50V	72982	8121-N088Z5U104M
C2447	283-0156-00			CAP., FXD, CER DI:1000PF, +100-0%, 200V	72982	8111A208Z5U0102Z
C2449	283-0181-00			CAP., FXD, CER DI:1.8PF, 10%, 100V	72982	8101B121COK0189B
C2451	281-0221-00			CAP., VAR, CER DI:2-10PF, 100V	72982	0513013A 2.0-10
C2453	283-0348-00			CAP., FXD, CER DI:0.5PF, +/-0.1PF, 100V	51642	100-100-NP0-508B
C2455	283-0348-00			CAP., FXD, CER DI:0.5PF, +/-0.1PF, 100V	51642	100-100-NP0-508B
C2457	281-0202-00			CAP., VAR, PLSTC: 1.5-5.5PF, 100V	80031	2807C1R406MM02F
C2461	283-0309-00			CAP., FXD, CER DI:150PF, 10%, 50V	04222	ULA355A151K1T60
C2464	283-0156-00	B010100	B010129X	CAP., FXD, CER DI:1000PF, +100-0%, 200V	72982	8111A208Z5U0102Z
C2473	283-0069-00			CAP., FXD, CER DI:15PF, 20%, 50V	72982	811-059C0G0150M
C2475	283-0069-00			CAP., FXD, CER DI:15PF, 20%, 50V	72982	811-059C0G0150M
C2483	283-0672-00			CAP., FXD, MICA D:200PF, 1%, 500V	00853	D155F2010FO
C2484	283-0325-00			CAP., FXD, CER DI:47PF, 10%, 100V	72982	A02AL9A4LC1G470K
C2485	283-0325-00			CAP., FXD, CER DI:47PF, 10%, 100V	72982	A02AL9A4LC1G470K
C2491	283-0177-00			CAP., FXD, CER DI:1UF, +80-20%, 25V	56289	273C5
C2493	283-0177-00			CAP., FXD, CER DI:1UF, +80-20%, 25V	56289	273C5
C2495	281-0523-00			CAP., FXD, CER DI:100PF, +/-20PF, 500V	72982	301-000U2M0101M
C2497	283-0177-00			CAP., FXD, CER DI:1UF, +80-20%, 25V	56289	273C5
C2591	290-0718-00			CAP., FXD, ELCTLT:22UF, 20%, 35V	56289	196D226X0035PE4
C2601	290-0527-00			CAP., FXD, ELCTLT:15UF, 20%, 20V	90201	TDC156M020FL
C2603	290-0527-00			CAP., FXD, ELCTLT:15UF, 20%, 20V	90201	TDC156M020FL
C2620	281-0504-00			CAP., FXD, CER DI:10PF, +/-1PF, 500V	59660	301-055C0G0100F
C2661	290-0531-00			CAP., FXD, ELCTLT:100UF, 20%, 10V	90201	TDC107M010WLC
C2663	290-0531-00			CAP., FXD, ELCTLT:100UF, 20%, 10V	90201	TDC107M010WLC
C2690	283-0111-00			CAP., FXD, CER DI:0.1UF, 20%, 50V	72982	8121-N088Z5U104M
C2691	283-0111-00			CAP., FXD, CER DI:0.1UF, 20%, 50V	72982	8121-N088Z5U104M
C2692	281-0697-00			CAP., FXD, CER DI:5000PF, +100-0%, 100V	80009	281-0697-00
C2695	283-0111-00			CAP., FXD, CER DI:0.1UF, 20%, 50V	72982	8121-N088Z5U104M
C2699	283-0156-00			CAP., FXD, CER DI:1000PF, +100-0%, 200V	72982	8111A208Z5U0102Z
C2701	283-0111-00			CAP., FXD, CER DI:0.1UF, 20%, 50V	72982	8121-N088Z5U104M
C2704	281-0697-00			CAP., FXD, CER DI:5000PF, +100-0%, 100V	80009	281-0697-00
C2705	283-0156-00			CAP., FXD, CER DI:1000PF, +100-0%, 200V	72982	8111A208Z5U0102Z
C2711	283-0140-00			CAP., FXD, CER DI:4.7PF, 5%, 50V	72982	8101E003A479C
C2717	283-0111-00			CAP., FXD, CER DI:0.1UF, 20%, 50V	72982	8121-N088Z5U104M
C2723	283-0156-00			CAP., FXD, CER DI:1000PF, +100-0%, 200V	72982	8111A208Z5U0102Z
C2725	283-0111-00			CAP., FXD, CER DI:0.1UF, 20%, 50V	72982	8121-N088Z5U104M
C2733	283-0111-00			CAP., FXD, CER DI:0.1UF, 20%, 50V	72982	8121-N088Z5U104M
C2734	283-0156-00			CAP., FXD, CER DI:1000PF, +100-0%, 200V	72982	8111A208Z5U0102Z
C2739	283-0318-00			CAP., FXD, CER DI:10PF, 100V	04222	ULA151A100K2
C2743	283-0111-00			CAP., FXD, CER DI:0.1UF, 20%, 50V	72982	8121-N088Z5U104M
C2744	281-0697-00			CAP., FXD, CER DI:5000PF, +100-0%, 100V	80009	281-0697-00
C2749	283-0156-00			CAP., FXD, CER DI:1000PF, +100-0%, 200V	72982	8111A208Z5U0102Z
C2753	283-0309-00			CAP., FXD, CER DI:150PF, 10%, 50V	04222	ULA355A151K1T60
C2757	283-0156-00			CAP., FXD, CER DI:1000PF, +100-0%, 200V	72982	8111A208Z5U0102Z
C2759	283-0309-00			CAP., FXD, CER DI:150PF, 10%, 50V	04222	ULA355A151K1T60
C2761	283-0111-00			CAP., FXD, CER DI:0.1UF, 20%, 50V	72982	8121-N088Z5U104M
C2767	283-0111-00			CAP., FXD, CER DI:0.1UF, 20%, 50V	72982	8121-N088Z5U104M
C2771	283-0156-00			CAP., FXD, CER DI:1000PF, +100-0%, 200V	72982	8111A208Z5U0102Z
C2773	283-0318-00			CAP., FXD, CER DI:10PF, 100V	04222	ULA151A100K2
C2775	283-0156-00			CAP., FXD, CER DI:1000PF, +100-0%, 200V	72982	8111A208Z5U0102Z
C2781	283-0309-00			CAP., FXD, CER DI:150PF, 10%, 50V	04222	ULA355A151K1T60

Replaceable Electrical Parts—7L18 Service

Ckt No.	Tektronix Part No.	Serial/Model No. Eff	Dscont	Name & Description	Mfr Code	Mfr Part Number
C2785	283-0156-00			CAP., FXD, CER DI:1000PF, +100-0%, 200V	72982	8111A208Z5U0102Z
C2787	283-0309-00			CAP., FXD, CER DI:150PF, 10%, 50V	04222	ULA355A151K1T60
C2789	283-0111-00			CAP., FXD, CER DI:0.1UF, 20%, 50V	72982	8121-N088Z5U104M
C2795	283-0111-00			CAP., FXD, CER DI:0.1UF, 20%, 50V	72982	8121-N088Z5U104M
C2799	283-0156-00			CAP., FXD, CER DI:1000PF, +100-0%, 200V	72982	8111A208Z5U0102Z
C2800	283-0156-00			CAP., FXD, CER DI:1000PF, +100-0%, 200V	72982	8111A208Z5U0102Z
C2801	283-0309-00			CAP., FXD, CER DI:150PF, 10%, 50V	04222	ULA355A151K1T60
C2802	281-0697-00			CAP., FXD, CER DI:5000PF, +100-0%, 100V	80009	281-0697-00
C2803	283-0111-00			CAP., FXD, CER DI:0.1UF, 20%, 50V	72982	8121-N088Z5U104M
C2807	283-0156-00			CAP., FXD, CER DI:1000PF, +100-0%, 200V	72982	8111A208Z5U0102Z
C2808	283-0156-00			CAP., FXD, CER DI:1000PF, +100-0%, 200V	72982	8111A208Z5U0102Z
C2813	283-0318-00			CAP., FXD, CER DI:10PF, 100V	04222	ULA151A100K2
C2814	283-0158-00			CAP., FXD, CER DI:1PF, 10%, 50V	72982	8101B057C0K0109B
C2815	281-0168-00			CAP., VAR, AIR DI:1.3-5.4PF, 250V	74970	187-0103-035
C2816	283-0156-00			CAP., FXD, CER DI:1000PF, +100-0%, 200V	72982	8111A208Z5U0102Z
C2817	283-0156-00			CAP., FXD, CER DI:1000PF, +100-0%, 200V	72982	8111A208Z5U0102Z
C2818	281-0697-00			CAP., FXD, CER DI:5000PF, +100-0%, 100V	80009	281-0697-00
C2820	283-0158-00			CAP., FXD, CER DI:1PF, 10%, 50V	72982	8101B057C0K0109B
C2821	281-0168-00			CAP., VAR, AIR DI:1.3-5.4PF, 250V	74970	187-0103-035
C2823	283-0318-00			CAP., FXD, CER DI:10PF, 100V	04222	ULA151A100K2
C2825	283-0193-00			CAP., FXD, CER DI:510PF, 2%, 100V	72982	8121N130C0G0511G
C2828	283-0111-00			CAP., FXD, CER DI:0.1UF, 20%, 50V	72982	8121-N088Z5U104M
C2829	283-0193-00			CAP., FXD, CER DI:510PF, 2%, 100V	72982	8121N130C0G0511G
C2833	283-0348-00	XB020350		CAP., FXD, CER DI:0.5PF, +/-0.1PF, 100V	51642	100-100-NP0-508B
C2834	281-0697-00			CAP., FXD, CER DI:5000PF, +100-0%, 100V	80009	281-0697-00
C2836	281-0697-00			CAP., FXD, CER DI:5000PF, +100-0%, 100V	80009	281-0697-00
C2837	283-0111-00			CAP., FXD, CER DI:0.1UF, 20%, 50V	72982	8121-N088Z5U104M
C2880	290-0513-00			CAP., FXD, ELCTLT:510UF, +75-10%, 25V	56289	109D575
C2894	290-0513-00	XB020165		CAP., FXD, ELCTLT:510UF, +75-10%, 25V	56289	109D575
C2900	-----			(FURNISHED AS A UNIT WITH 672-0589-00)		
C3000	283-0204-00			CAP., FXD, CER DI:0.01UF, 20%, 50V	72982	8121N061Z5U0103M
C3004	283-0204-00			CAP., FXD, CER DI:0.01UF, 20%, 50V	72982	8121N061Z5U0103M
C3010	283-0204-00			CAP., FXD, CER DI:0.01UF, 20%, 50V	72982	8121N061Z5U0103M
C3011	283-0111-00			CAP., FXD, CER DI:0.1UF, 20%, 50V	72982	8121-N088Z5U104M
C3012	283-0204-00			CAP., FXD, CER DI:0.01UF, 20%, 50V	72982	8121N061Z5U0103M
C3018	283-0111-00			CAP., FXD, CER DI:0.1UF, 20%, 50V	72982	8121-N088Z5U104M
C3022	283-0111-00			CAP., FXD, CER DI:0.1UF, 20%, 50V	72982	8121-N088Z5U104M
C3024	283-0204-00			CAP., FXD, CER DI:0.01UF, 20%, 50V	72982	8121N061Z5U0103M
C3028	283-0204-00			CAP., FXD, CER DI:0.01UF, 20%, 50V	72982	8121N061Z5U0103M
C3040	283-0111-00			CAP., FXD, CER DI:0.1UF, 20%, 50V	72982	8121-N088Z5U104M
C3044	283-0111-00			CAP., FXD, CER DI:0.1UF, 20%, 50V	72982	8121-N088Z5U104M
C3046	281-0562-00			CAP., FXD, CER DI:39PF, 10%, 500V	59660	301-000U2J0390K
C3056	283-0204-00			CAP., FXD, CER DI:0.01UF, 20%, 50V	72982	8121N061Z5U0103M
C3060	283-0204-00			CAP., FXD, CER DI:0.01UF, 20%, 50V	72982	8121N061Z5U0103M
C3062	283-0204-00			CAP., FXD, CER DI:0.01UF, 20%, 50V	72982	8121N061Z5U0103M
C3068	283-0111-00			CAP., FXD, CER DI:0.1UF, 20%, 50V	72982	8121-N088Z5U104M
C3078	283-0204-00			CAP., FXD, CER DI:0.01UF, 20%, 50V	72982	8121N061Z5U0103M
C3080	283-0204-00			CAP., FXD, CER DI:0.01UF, 20%, 50V	72982	8121N061Z5U0103M
C3086	283-0204-00			CAP., FXD, CER DI:0.01UF, 20%, 50V	72982	8121N061Z5U0103M
C3088	283-0111-00			CAP., FXD, CER DI:0.1UF, 20%, 50V	72982	8121-N088Z5U104M
C3092	283-0204-00			CAP., FXD, CER DI:0.01UF, 20%, 50V	72982	8121N061Z5U0103M
C3098	283-0204-00			CAP., FXD, CER DI:0.01UF, 20%, 50V	72982	8121N061Z5U0103M
C3100	283-0204-00			CAP., FXD, CER DI:0.01UF, 20%, 50V	72982	8121N061Z5U0103M
C3102	283-0204-00			CAP., FXD, CER DI:0.01UF, 20%, 50V	72982	8121N061Z5U0103M
C3106	281-0562-00			CAP., FXD, CER DI:39PF, 10%, 500V	59660	301-000U2J0390K
C3110	283-0204-00			CAP., FXD, CER DI:0.01UF, 20%, 50V	72982	8121N061Z5U0103M
C3132	283-0111-00			CAP., FXD, CER DI:0.1UF, 20%, 50V	72982	8121-N088Z5U104M

Ckt No.	Tektronix Part No.	Serial/Model No. Eff	Dscont	Name & Description	Mfr Code	Mfr Part Number
C3134	283-0111-00			CAP., FXD, CER DI:0.1UF, 20%, 50V	72982	8121-N088Z5U104M
C3138	283-0111-00			CAP., FXD, CER DI:0.1UF, 20%, 50V	72982	8121-N088Z5U104M
C3142	283-0204-00			CAP., FXD, CER DI:0.01UF, 20%, 50V	72982	8121N061Z5U0103M
C3150	283-0204-00			CAP., FXD, CER DI:0.01UF, 20%, 50V	72982	8121N061Z5U0103M
C3154	283-0204-00			CAP., FXD, CER DI:0.01UF, 20%, 50V	72982	8121N061Z5U0103M
C3156	283-0204-00			CAP., FXD, CER DI:0.01UF, 20%, 50V	72982	8121N061Z5U0103M
C3157	283-0204-00			CAP., FXD, CER DI:0.01UF, 20%, 50V	72982	8121N061Z5U0103M
C3158	283-0204-00			CAP., FXD, CER DI:0.01UF, 20%, 50V	72982	8121N061Z5U0103M
C3160	283-0191-00			CAP., FXD, CER DI:0.022UF, 20%, 50V	72982	8121N075Z5U0223M
C3162	283-0204-00			CAP., FXD, CER DI:0.01UF, 20%, 50V	72982	8121N061Z5U0103M
C3164	283-0204-00			CAP., FXD, CER DI:0.01UF, 20%, 50V	72982	8121N061Z5U0103M
C3170	283-0204-00			CAP., FXD, CER DI:0.01UF, 20%, 50V	72982	8121N061Z5U0103M
C3172	283-0204-00			CAP., FXD, CER DI:0.01UF, 20%, 50V	72982	8121N061Z5U0103M
C3174	283-0204-00			CAP., FXD, CER DI:0.01UF, 20%, 50V	72982	8121N061Z5U0103M
C3176	283-0204-00			CAP., FXD, CER DI:0.01UF, 20%, 50V	72982	8121N061Z5U0103M
C3178	283-0204-00			CAP., FXD, CER DI:0.01UF, 20%, 50V	72982	8121N061Z5U0103M
C3179	283-0204-00			CAP., FXD, CER DI:0.01UF, 20%, 50V	72982	8121N061Z5U0103M
C3190	281-0092-00	B010100	B020399	CAP., VAR, CER DI:9-35PF, 200V	72982	538-011 D9-35
C3190	281-0167-00	B020400		CAP., VAR, CER DI:9-45PF, 200V	72982	538-011-D 9-45
C3192	283-0600-00			CAP., FXD, MICA D:43PF, 5%, 500V	00853	D105E430J0
C3194	283-0603-00	B010100	B020399	CAP., FXD, MICA D:113PF, 2%, 300V	00853	D153F1130G0
C3194	283-0649-00	B020400		CAP., FXD, MICA D:105PF, 1%, 300V	00853	D153F1050F0
C3195	281-0092-00	B010100	B020399	CAP., VAR, CER DI:9-35PF, 200V	72982	538-011 D9-35
C3195	281-0167-00	B020400		CAP., VAR, CER DI:9-45PF, 200V	72982	538-011-D 9-45
C3196	281-0615-00			CAP., FXD, CER DI:3.9PF, +/-0.5PF, 200V	59660	374001C0J0399D
C3197	283-0647-00	XB020400		CAP., FXD, MICA D:70PF, 1%, 100V	00853	D151E700F0
C3198	283-0644-00	B010100	B020399	CAP., FXD, MICA D:150PF, 1%, 500V	00853	D155E151F0
C3198	283-0647-00	B020400		CAP., FXD, MICA D:70PF, 1%, 100V	00853	D151E700F0
C3200	281-0092-00	B010100	B020399	CAP., VAR, CER DI:9-35PF, 200V	72982	538-011 D9-35
C3200	281-0167-00	B020400		CAP., VAR, CER DI:9-45PF, 200V	72982	538-011-D 9-45
C3202	281-0615-00			CAP., FXD, CER DI:3.9PF, +/-0.5PF, 200V	59660	374001C0J0399D
C3204	283-0618-00	B010100	B020399	CAP., FXD, MICA D:130PF, 2%, 400V	00853	D155E131G0
C3204	283-0728-00	B020400		CAP., FXD, MICA D:120PF, 1%, 500V	00853	D155F121F03
C3206	283-0642-00			CAP., FXD, MICA D:33PF, +/-0.5PF, 300V	00853	D10-5E330G
C3212	283-0204-00			CAP., FXD, CER DI:0.01UF, 20%, 50V	72982	8121N061Z5U0103M
C3213	283-0204-00			CAP., FXD, CER DI:0.01UF, 20%, 50V	72982	8121N061Z5U0103M
C3216	283-0204-00			CAP., FXD, CER DI:0.01UF, 20%, 50V	72982	8121N061Z5U0103M
C3224	283-0204-00			CAP., FXD, CER DI:0.01UF, 20%, 50V	72982	8121N061Z5U0103M
C3226	283-0204-00			CAP., FXD, CER DI:0.01UF, 20%, 50V	72982	8121N061Z5U0103M
C3228	283-0204-00			CAP., FXD, CER DI:0.01UF, 20%, 50V	72982	8121N061Z5U0103M
C3234	283-0204-00			CAP., FXD, CER DI:0.01UF, 20%, 50V	72982	8121N061Z5U0103M
C3240	283-0204-00			CAP., FXD, CER DI:0.01UF, 20%, 50V	72982	8121N061Z5U0103M
C3242	283-0204-00			CAP., FXD, CER DI:0.01UF, 20%, 50V	72982	8121N061Z5U0103M
C3246	283-0204-00			CAP., FXD, CER DI:0.01UF, 20%, 50V	72982	8121N061Z5U0103M
C3248	283-0204-00			CAP., FXD, CER DI:0.01UF, 20%, 50V	72982	8121N061Z5U0103M
C3250	283-0204-00			CAP., FXD, CER DI:0.01UF, 20%, 50V	72982	8121N061Z5U0103M
C3260	283-0204-00			CAP., FXD, CER DI:0.01UF, 20%, 50V	72982	8121N061Z5U0103M
C3262	283-0111-00			CAP., FXD, CER DI:0.1UF, 20%, 50V	72982	8121-N088Z5U104M
C3266	283-0204-00			CAP., FXD, CER DI:0.01UF, 20%, 50V	72982	8121N061Z5U0103M
C3270	283-0204-00			CAP., FXD, CER DI:0.01UF, 20%, 50V	72982	8121N061Z5U0103M
C3272	283-0204-00			CAP., FXD, CER DI:0.01UF, 20%, 50V	72982	8121N061Z5U0103M
C3274	283-0204-00			CAP., FXD, CER DI:0.01UF, 20%, 50V	72982	8121N061Z5U0103M
C3278	283-0204-00			CAP., FXD, CER DI:0.01UF, 20%, 50V	72982	8121N061Z5U0103M
C3280	283-0204-00			CAP., FXD, CER DI:0.01UF, 20%, 50V	72982	8121N061Z5U0103M
C3284	283-0204-00			CAP., FXD, CER DI:0.01UF, 20%, 50V	72982	8121N061Z5U0103M
C3286	283-0204-00			CAP., FXD, CER DI:0.01UF, 20%, 50V	72982	8121N061Z5U0103M
C3300	283-0111-00			CAP., FXD, CER DI:0.1UF, 20%, 50V	72982	8121-N088Z5U104M

Replaceable Electrical Parts—7L18 Service

Kct No.	Tektronix Part No.	Serial/Model No. Eff Dscont	Name & Description	Mfr Code	Mfr Part Number
C3301	283-0353-00		CAP., FXD, CER DI:0.1UF, 10%, 50V	95275	VJ1210Y104K-H
C3302	283-0111-00		CAP., FXD, CER DI:0.1UF, 20%, 50V	72982	8121-N088Z5U104M
C3303	283-0353-00		CAP., FXD, CER DI:0.1UF, 10%, 50V	95275	VJ1210Y104K-H
C3304	283-0111-00		CAP., FXD, CER DI:0.1UF, 20%, 50V	72982	8121-N088Z5U104M
C3305	283-0204-00		CAP., FXD, CER DI:0.01UF, 20%, 50V	72982	8121N061Z5U0103M
C3306	283-0111-00		CAP., FXD, CER DI:0.1UF, 20%, 50V	72982	8121-N088Z5U104M
C3308	283-0353-00		CAP., FXD, CER DI:0.1UF, 10%, 50V	95275	VJ1210Y104K-H
C3309	283-0353-00		CAP., FXD, CER DI:0.1UF, 10%, 50V	95275	VJ1210Y104K-H
C3310	283-0204-00		CAP., FXD, CER DI:0.01UF, 20%, 50V	72982	8121N061Z5U0103M
C3311	283-0204-00		CAP., FXD, CER DI:0.01UF, 20%, 50V	72982	8121N061Z5U0103M
C3312	283-0204-00		CAP., FXD, CER DI:0.01UF, 20%, 50V	72982	8121N061Z5U0103M
C3313	283-0204-00		CAP., FXD, CER DI:0.01UF, 20%, 50V	72982	8121N061Z5U0103M
C3314	283-0204-00		CAP., FXD, CER DI:0.01UF, 20%, 50V	72982	8121N061Z5U0103M
C3315	283-0111-00		CAP., FXD, CER DI:0.1UF, 20%, 50V	72982	8121-N088Z5U104M
C3316	283-0204-00		CAP., FXD, CER DI:0.01UF, 20%, 50V	72982	8121N061Z5U0103M
C3317	283-0204-00		CAP., FXD, CER DI:0.01UF, 20%, 50V	72982	8121N061Z5U0103M
C3318	283-0204-00		CAP., FXD, CER DI:0.01UF, 20%, 50V	72982	8121N061Z5U0103M
C3319	283-0204-00		CAP., FXD, CER DI:0.01UF, 20%, 50V	72982	8121N061Z5U0103M
C3320	283-0204-00		CAP., FXD, CER DI:0.01UF, 20%, 50V	72982	8121N061Z5U0103M
C3321	283-0204-00		CAP., FXD, CER DI:0.01UF, 20%, 50V	72982	8121N061Z5U0103M
C3322	283-0204-00		CAP., FXD, CER DI:0.01UF, 20%, 50V	72982	8121N061Z5U0103M
C3323	283-0204-00		CAP., FXD, CER DI:0.01UF, 20%, 50V	72982	8121N061Z5U0103M
C3324	283-0204-00		CAP., FXD, CER DI:0.01UF, 20%, 50V	72982	8121N061Z5U0103M
C3325	283-0204-00		CAP., FXD, CER DI:0.01UF, 20%, 50V	72982	8121N061Z5U0103M
C3326	283-0204-00		CAP., FXD, CER DI:0.01UF, 20%, 50V	72982	8121N061Z5U0103M
C3327	283-0204-00		CAP., FXD, CER DI:0.01UF, 20%, 50V	72982	8121N061Z5U0103M
C3328	283-0204-00		CAP., FXD, CER DI:0.01UF, 20%, 50V	72982	8121N061Z5U0103M
C3329	283-0204-00		CAP., FXD, CER DI:0.01UF, 20%, 50V	72982	8121N061Z5U0103M
C3330	283-0204-00		CAP., FXD, CER DI:0.01UF, 20%, 50V	72982	8121N061Z5U0103M
C3331	283-0204-00		CAP., FXD, CER DI:0.01UF, 20%, 50V	72982	8121N061Z5U0103M
C3332	283-0204-00		CAP., FXD, CER DI:0.01UF, 20%, 50V	72982	8121N061Z5U0103M
C3333	283-0111-00		CAP., FXD, CER DI:0.1UF, 20%, 50V	72982	8121-N088Z5U104M
C3334	283-0204-00		CAP., FXD, CER DI:0.01UF, 20%, 50V	72982	8121N061Z5U0103M
C3335	283-0353-00		CAP., FXD, CER DI:0.1UF, 10%, 50V	95275	VJ1210Y104K-H
C3336	283-0204-00		CAP., FXD, CER DI:0.01UF, 20%, 50V	72982	8121N061Z5U0103M
C3337	283-0353-00		CAP., FXD, CER DI:0.1UF, 10%, 50V	95275	VJ1210Y104K-H
C3338	283-0204-00		CAP., FXD, CER DI:0.01UF, 20%, 50V	72982	8121N061Z5U0103M
C3339	283-0204-00		CAP., FXD, CER DI:0.01UF, 20%, 50V	72982	8121N061Z5U0103M
C3340	283-0204-00		CAP., FXD, CER DI:0.01UF, 20%, 50V	72982	8121N061Z5U0103M
C3341	283-0353-00		CAP., FXD, CER DI:0.1UF, 10%, 50V	95275	VJ1210Y104K-H
C3342	283-0204-00		CAP., FXD, CER DI:0.01UF, 20%, 50V	72982	8121N061Z5U0103M
C3343	283-0353-00		CAP., FXD, CER DI:0.1UF, 10%, 50V	95275	VJ1210Y104K-H
C3344	283-0204-00		CAP., FXD, CER DI:0.01UF, 20%, 50V	72982	8121N061Z5U0103M
C3345	283-0111-00		CAP., FXD, CER DI:0.1UF, 20%, 50V	72982	8121-N088Z5U104M
C3346	283-0204-00		CAP., FXD, CER DI:0.01UF, 20%, 50V	72982	8121N061Z5U0103M
C3347	283-0353-00		CAP., FXD, CER DI:0.1UF, 10%, 50V	95275	VJ1210Y104K-H
C3348	283-0204-00		CAP., FXD, CER DI:0.01UF, 20%, 50V	72982	8121N061Z5U0103M
C3349	283-0204-00		CAP., FXD, CER DI:0.01UF, 20%, 50V	72982	8121N061Z5U0103M
C3350	283-0204-00		CAP., FXD, CER DI:0.01UF, 20%, 50V	72982	8121N061Z5U0103M
C3352	283-0204-00		CAP., FXD, CER DI:0.01UF, 20%, 50V	72982	8121N061Z5U0103M
C3353	283-0204-00		CAP., FXD, CER DI:0.01UF, 20%, 50V	72982	8121N061Z5U0103M
C3354	283-0204-00		CAP., FXD, CER DI:0.01UF, 20%, 50V	72982	8121N061Z5U0103M
C3355	283-0204-00		CAP., FXD, CER DI:0.01UF, 20%, 50V	72982	8121N061Z5U0103M
C3358	283-0204-00		CAP., FXD, CER DI:0.01UF, 20%, 50V	72982	8121N061Z5U0103M
C3362	283-0111-00		CAP., FXD, CER DI:0.1UF, 20%, 50V	72982	8121-N088Z5U104M
C3366	283-0204-00		CAP., FXD, CER DI:0.01UF, 20%, 50V	72982	8121N061Z5U0103M
C3368	283-0204-00		CAP., FXD, CER DI:0.01UF, 20%, 50V	72982	8121N061Z5U0103M

Ckt No.	Tektronix Part No.	Serial/Model No. Eff	Dscont	Name & Description	Mfr Code	Mfr Part Number
C3370	283-0204-00			CAP., FXD, CER DI:0.01UF, 20%, 50V	72982	8121N061Z5U0103M
C3372	283-0204-00			CAP., FXD, CER DI:0.01UF, 20%, 50V	72982	8121N061Z5U0103M
C3374	283-0204-00			CAP., FXD, CER DI:0.01UF, 20%, 50V	72982	8121N061Z5U0103M
C3376	283-0204-00			CAP., FXD, CER DI:0.01UF, 20%, 50V	72982	8121N061Z5U0103M
C3420	283-0238-00			CAP., FXD, CER DI:0.01UF, 10%, 50V	72982	8121N075X7R0103K
C3422	283-0238-00			CAP., FXD, CER DI:0.01UF, 10%, 50V	72982	8121N075X7R0103K
C3424	283-0728-00	B010100	B020399	CAP., FXD, MICA D:120PF, 1%, 500V	00853	D155F121F03
C3424	283-0630-00	B020400		CAP., FXD, MICA D:110PF, 1%, 100V	00853	D151E111F0
C3425	281-0097-00	B010100	B020399	CAP., VAR, CER DI:9-35PF, 200V	72982	538-006-D9-35
C3425	281-0240-00	B020400		CAP., VAR, CER DI:9-45PF, 200V	72982	538-006-D9-45
C3426	283-0600-00			CAP., FXD, MICA D:43PF, 5%, 500V	00853	D105E430J0
C3428	281-0615-00			CAP., FXD, CER DI:3.9PF, +/-0.5PF, 200V	59660	374001C0J0399D
C3430	283-0238-00			CAP., FXD, CER DI:0.01UF, 10%, 50V	72982	8121N075X7R0103K
C3432	283-0238-00			CAP., FXD, CER DI:0.01UF, 10%, 50V	72982	8121N075X7R0103K
C3434	283-0640-00	B010100	B020399	CAP., FXD, MICA D:160PF, 1%, 100V	00853	D151E161F0
C3434	283-0644-00	B020400		CAP., FXD, MICA D:150PF, 1%, 500V	00853	D155E151F0
C3436	281-0097-00	B010100	B020399	CAP., VAR, CER DI:9-35PF, 200V	72982	538-006-D9-35
C3436	281-0240-00	B020400		CAP., VAR, CER DI:9-45PF, 200V	72982	538-006-D9-45
C3438	281-0615-00			CAP., FXD, CER DI:3.9PF, +/-0.5PF, 200V	59660	374001C0J0399D
C3440	283-0238-00			CAP., FXD, CER DI:0.01UF, 10%, 50V	72982	8121N075X7R0103K
C3442	283-0642-00			CAP., FXD, MICA D:33PF, +/-0.5PF, 300V	00853	D10-5E330G
C3444	283-0618-00	B010100	B020399	CAP., FXD, MICA D:130PF, 2%, 400V	00853	D155E131G0
C3444	283-0728-00	B020400		CAP., FXD, MICA D:120PF, 1%, 500V	00853	D155F121F03
C3446	281-0097-00	B010100	B020399	CAP., VAR, CER DI:9-35PF, 200V	72982	538-006-D9-35
C3446	281-0240-00	B020400		CAP., VAR, CER DI:9-45PF, 200V	72982	538-006-D9-45
C3449	283-0238-00			CAP., FXD, CER DI:0.01UF, 10%, 50V	72982	8121N075X7R0103K
C3450	283-0111-00			CAP., FXD, CER DI:0.1UF, 20%, 50V	72982	8121-N088Z5U104M
C3451	283-0111-00			CAP., FXD, CER DI:0.1UF, 20%, 50V	72982	8121-N088Z5U104M
C3452	283-0238-00			CAP., FXD, CER DI:0.01UF, 10%, 50V	72982	8121N075X7R0103K
C3453	283-0594-00			CAP., FXD, MICA D:0.001UF, 1%, 100V	00853	D151F102F0
C3454	281-0226-00			CAP., VAR, PLSTC:5.5-65PF, 100V	52769	GXD38000
C3455	283-0111-00			CAP., FXD, CER DI:0.1UF, 20%, 50V	72982	8121-N088Z5U104M
C3456	283-0111-00			CAP., FXD, CER DI:0.1UF, 20%, 50V	72982	8121-N088Z5U104M
C3457	283-0642-00			CAP., FXD, MICA D:33PF, +/-0.5PF, 300V	00853	D10-5E330G
C3458	283-0624-00			CAP., FXD, MICA D:1300PF, 2%, 500V	00853	D195E132G0
C3459	283-0604-00			CAP., FXD, MICA D:304PF, 2%, 300V	00853	D153F3040G0
C3462	283-0111-00			CAP., FXD, CER DI:0.1UF, 20%, 50V	72982	8121-N088Z5U104M
C3464	283-0111-00			CAP., FXD, CER DI:0.1UF, 20%, 50V	72982	8121-N088Z5U104M
C3466	283-0111-00			CAP., FXD, CER DI:0.1UF, 20%, 50V	72982	8121-N088Z5U104M
C3468	283-0111-00			CAP., FXD, CER DI:0.1UF, 20%, 50V	72982	8121-N088Z5U104M
C3480	283-0111-00			CAP., FXD, CER DI:0.1UF, 20%, 50V	72982	8121-N088Z5U104M
C3481	283-0167-00			CAP., FXD, CER DI:0.1UF, 10%, 100V	72982	8131N145X5R0104K
C3482	283-0167-00			CAP., FXD, CER DI:0.1UF, 10%, 100V	72982	8131N145X5R0104K
C3484	283-0167-00			CAP., FXD, CER DI:0.1UF, 10%, 100V	72982	8131N145X5R0104K
C3486	283-0111-00			CAP., FXD, CER DI:0.1UF, 20%, 50V	72982	8121-N088Z5U104M
C3492	283-0077-00			CAP., FXD, CER DI:330PF, 5%, 500V	59660	831-500B331J
C3494	281-0629-00			CAP., FXD, CER DI:33PF, 5%, 600V	04222	7027-0260
C3498	290-0340-00			CAP., FXD, ELCTLT:10UF, 10%, 50V	56289	109D106X9050C2
C3500	283-0000-00			CAP., FXD, CER DI:0.001UF, +100-0%, 500V	59660	831-519-Z5U-102P
C3516	283-0204-00			CAP., FXD, CER DI:0.01UF, 20%, 50V	72982	8121N061Z5U0103M
C3520	281-0509-00			CAP., FXD, CER DI:15PF, +/-1.5PF, 500V	59660	301-000C0G0150K
C3524	283-0203-00			CAP., FXD, CER DI:0.47UF, 20%, 50V	72982	8131N075E474M
C3529	283-0154-00	XB020300		CAP., FXD, CER DI:22PF, 5%, 50V	72982	8111B061C0G220J
C3532	283-0197-00	XB020200		CAP., FXD, CER DI:470PF, 5%, 100V	72982	8121N075C0G0471J
C3533	283-0177-00			CAP., FXD, CER DI:1UF, +80-20%, 25V	56289	273C5
C3534	283-0203-00			CAP., FXD, CER DI:0.47UF, 20%, 50V	72982	8131N075E474M
C3536	281-0509-00			CAP., FXD, CER DI:15PF, +/-1.5PF, 500V	59660	301-000C0G0150K

Replaceable Electrical Parts—7L18 Service

Ckt No.	Tektronix Part No.	Serial/Model No. Eff	Dscont	Name & Description	Mfr Code	Mfr Part Number
C3540	283-0176-00	B010100	B010159	CAP., FXD, CER DI:0.0022UF, 20%, 50V	72982	8121B058X7R0222M
C3540	283-0119-00	B010160		CAP., FXD, CER DI:2200PF, 5%, 200V	59660	855-536Y5E0222J
C3546	283-0177-00			CAP., FXD, CER DI:1UF, +80-20%, 25V	56289	273C5
C3547	283-0177-00			CAP., FXD, CER DI:1UF, +80-20%, 25V	56289	273C5
C3548	283-0203-00			CAP., FXD, CER DI:0.47UF, 20%, 50V	72982	8131N075E474M
C3549	283-0203-00			CAP., FXD, CER DI:0.47UF, 20%, 50V	72982	8131N075E474M
C3550	283-0156-00	B010100	B010159	CAP., FXD, CER DI:1000PF, +100-0%, 200V	72982	8111A208Z5U0102Z
C3550	283-0084-00	B010160		CAP., FXD, CER DI:270PF, 5%, 1000V	72982	838-533B271J
C3552	283-0177-00			CAP., FXD, CER DI:1UF, +80-20%, 25V	56289	273C5
C3553	283-0154-00			CAP., FXD, CER DI:22PF, 5%, 50V	72982	8111B061COG220J
C3554	283-0177-00			CAP., FXD, CER DI:1UF, +80-20%, 25V	56289	273C5
C3556	290-0527-00			CAP., FXD, ELCTLT:15UF, 20%, 20V	90201	TDC156M020FL
C3557	283-0203-00			CAP., FXD, CER DI:0.47UF, 20%, 50V	72982	8131N075E474M
C3558	290-0527-00			CAP., FXD, ELCTLT:15UF, 20%, 20V	90201	TDC156M020FL
C3559	283-0203-00			CAP., FXD, CER DI:0.47UF, 20%, 50V	72982	8131N075E474M
C3560	290-0527-00			CAP., FXD, ELCTLT:15UF, 20%, 20V	90201	TDC156M020FL
C3561	283-0203-00			CAP., FXD, CER DI:0.47UF, 20%, 50V	72982	8131N075E474M
C3562	290-0527-00			CAP., FXD, ELCTLT:15UF, 20%, 20V	90201	TDC156M020FL
C3563	283-0203-00			CAP., FXD, CER DI:0.47UF, 20%, 50V	72982	8131N075E474M
C3564	283-0156-00	B010100	B010159	CAP., FXD, CER DI:1000PF, +100-0%, 200V	72982	8111A208Z5U0102Z
C3564	283-0084-00	B010160		CAP., FXD, CER DI:270PF, 5%, 1000V	72982	838-533B271J
C3565	283-0203-00			CAP., FXD, CER DI:0.47UF, 20%, 50V	72982	8131N075E474M
C3571	283-0203-00			CAP., FXD, CER DI:0.47UF, 20%, 50V	72982	8131N075E474M
C3580	283-0204-00			CAP., FXD, CER DI:0.01UF, 20%, 50V	72982	8121N061Z5U0103M
C3581	283-0156-00			CAP., FXD, CER DI:1000PF, +100-0%, 200V	72982	8111A208Z5U0102Z
C3620	283-0111-00			CAP., FXD, CER DI:0.1UF, 20%, 50V	72982	8121-N088Z5U104M
C3651	283-0156-00			CAP., FXD, CER DI:1000PF, +100-0%, 200V	72982	8111A208Z5U0102Z
C3653	283-0176-00			CAP., FXD, CER DI:0.0022UF, 20%, 50V	72982	8121B058X7R0222M
CR5A, B	152-0664-00			SEMICON D DEVICE:SWITCHING, SI, 70V	50434	5082-2800
CR130	152-0141-02			SEMICON D DEVICE:SILICON, 30V, 150MA	01295	1N4152R
CR134	152-0141-02			SEMICON D DEVICE:SILICON, 30V, 150MA	01295	1N4152R
CR141	152-0322-00			SEMICON D DEVICE:SILICON, 15V, HOT CARRIER	50434	5082-2672
CR160	152-0141-02			SEMICON D DEVICE:SILICON, 30V, 150MA	01295	1N4152R
CR176	152-0141-02			SEMICON D DEVICE:SILICON, 30V, 150MA	01295	1N4152R
CR178	152-0141-02			SEMICON D DEVICE:SILICON, 30V, 150MA	01295	1N4152R
CR180	152-0141-02			SEMICON D DEVICE:SILICON, 30V, 150MA	01295	1N4152R
CR181	152-0141-02			SEMICON D DEVICE:SILICON, 30V, 150MA	01295	1N4152R
CR182	152-0141-02			SEMICON D DEVICE:SILICON, 30V, 150MA	01295	1N4152R
CR183	152-0141-02			SEMICON D DEVICE:SILICON, 30V, 150MA	01295	1N4152R
CR184	152-0141-02			SEMICON D DEVICE:SILICON, 30V, 150MA	01295	1N4152R
CR186	152-0141-02			SEMICON D DEVICE:SILICON, 30V, 150MA	01295	1N4152R
CR187	152-0141-02			SEMICON D DEVICE:SILICON, 30V, 150MA	01295	1N4152R
CR188	152-0141-02			SEMICON D DEVICE:SILICON, 30V, 150MA	01295	1N4152R
CR190	152-0141-02			SEMICON D DEVICE:SILICON, 30V, 150MA	01295	1N4152R
CR191	152-0141-02			SEMICON D DEVICE:SILICON, 30V, 150MA	01295	1N4152R
CR192	152-0141-02			SEMICON D DEVICE:SILICON, 30V, 150MA	01295	1N4152R
CR193	152-0141-02			SEMICON D DEVICE:SILICON, 30V, 150MA	01295	1N4152R
CR194	152-0141-02			SEMICON D DEVICE:SILICON, 30V, 150MA	01295	1N4152R
CR198	152-0141-02			SEMICON D DEVICE:SILICON, 30V, 150MA	01295	1N4152R
CR200	152-0141-02			SEMICON D DEVICE:SILICON, 30V, 150MA	01295	1N4152R
CR202	152-0141-02			SEMICON D DEVICE:SILICON, 30V, 150MA	01295	1N4152R
CR204	152-0141-02			SEMICON D DEVICE:SILICON, 30V, 150MA	01295	1N4152R
CR206	152-0141-02			SEMICON D DEVICE:SILICON, 30V, 150MA	01295	1N4152R
CR208	152-0141-02			SEMICON D DEVICE:SILICON, 30V, 150MA	01295	1N4152R
CR210	152-0141-02			SEMICON D DEVICE:SILICON, 30V, 150MA	01295	1N4152R
CR212	152-0141-02			SEMICON D DEVICE:SILICON, 30V, 150MA	01295	1N4152R
CR214	152-0141-02			SEMICON D DEVICE:SILICON, 30V, 150MA	01295	1N4152R

Replaceable Electrical Parts—7L18 Service

Ckt No.	Tektronix Part No.	Serial/Model No. Eff	Dscont	Name & Description	Mfr Code	Mfr Part Number
CR216	152-0141-02			SEMICON D DEVICE: SILICON, 30V, 150MA	01295	1N4152R
CR218	152-0141-02			SEMICON D DEVICE: SILICON, 30V, 150MA	01295	1N4152R
CR220	152-0141-02			SEMICON D DEVICE: SILICON, 30V, 150MA	01295	1N4152R
CR222	152-0141-02			SEMICON D DEVICE: SILICON, 30V, 150MA	01295	1N4152R
CR224	152-0141-02			SEMICON D DEVICE: SILICON, 30V, 150MA	01295	1N4152R
CR226	152-0141-02			SEMICON D DEVICE: SILICON, 30V, 150MA	01295	1N4152R
CR228	152-0141-02			SEMICON D DEVICE: SILICON, 30V, 150MA	01295	1N4152R
CR230	152-0141-02			SEMICON D DEVICE: SILICON, 30V, 150MA	01295	1N4152R
CR232	152-0141-02			SEMICON D DEVICE: SILICON, 30V, 150MA	01295	1N4152R
CR240	152-0141-02			SEMICON D DEVICE: SILICON, 30V, 150MA	01295	1N4152R
CR260	152-0075-00			SEMICON D DEVICE: GE, 25V, 40MA	14433	G866
CR309	152-0141-02			SEMICON D DEVICE: SILICON, 30V, 150MA	01295	1N4152R
CR335	152-0141-02			SEMICON D DEVICE: SILICON, 30V, 150MA	01295	1N4152R
CR353	152-0141-02			SEMICON D DEVICE: SILICON, 30V, 150MA	01295	1N4152R
CR364	152-0141-02	XB010131		SEMICON D DEVICE: SILICON, 30V, 150MA	01295	1N4152R
CR366	152-0141-02	XB010131		SEMICON D DEVICE: SILICON, 30V, 150MA	01295	1N4152R
CR368	152-0141-02	XB010131		SEMICON D DEVICE: SILICON, 30V, 150MA	01295	1N4152R
CR370	152-0141-02	XB010131		SEMICON D DEVICE: SILICON, 30V, 150MA	01295	1N4152R
CR371	152-0075-00			SEMICON D DEVICE: GE, 25V, 40MA	14433	G866
CR372	152-0141-02	XB010131		SEMICON D DEVICE: SILICON, 30V, 150MA	01295	1N4152R
CR373	152-0075-00			SEMICON D DEVICE: GE, 25V, 40MA	14433	G866
CR374	152-0141-02	XB010131		SEMICON D DEVICE: SILICON, 30V, 150MA	01295	1N4152R
CR376	152-0141-02	XB010131		SEMICON D DEVICE: SILICON, 30V, 150MA	01295	1N4152R
CR381	152-0075-00			SEMICON D DEVICE: GE, 25V, 40MA	14433	G866
CR383	152-0075-00			SEMICON D DEVICE: GE, 25V, 40MA	14433	G866
CR385	152-0075-00			SEMICON D DEVICE: GE, 25V, 40MA	14433	G866
CR387	152-0075-00			SEMICON D DEVICE: GE, 25V, 40MA	14433	G866
CR389	152-0075-00			SEMICON D DEVICE: GE, 25V, 40MA	14433	G866
CR391	152-0075-00			SEMICON D DEVICE: GE, 25V, 40MA	14433	G866
CR393	152-0075-00			SEMICON D DEVICE: GE, 25V, 40MA	14433	G866
CR395	152-0075-00			SEMICON D DEVICE: GE, 25V, 40MA	14433	G866
CR466	152-0246-00			SEMICON D DEVICE: SW, SI, 40V, 200MA	03508	DE140
CR468	152-0246-00			SEMICON D DEVICE: SW, SI, 40V, 200MA	03508	DE140
CR476	152-0141-02			SEMICON D DEVICE: SILICON, 30V, 150MA	01295	1N4152R
CR489	152-0075-00			SEMICON D DEVICE: GE, 25V, 40MA	14433	G866
CR526	152-0075-00			SEMICON D DEVICE: GE, 25V, 40MA	14433	G866
CR544	152-0141-02			SEMICON D DEVICE: SILICON, 30V, 150MA	01295	1N4152R
CR546	152-0141-02			SEMICON D DEVICE: SILICON, 30V, 150MA	01295	1N4152R
CR563	152-0322-00			SEMICON D DEVICE: SILICON, 15V, HOT CARRIER	50434	5082-2672
CR565	152-0322-00			SEMICON D DEVICE: SILICON, 15V, HOT CARRIER	50434	5082-2672
CR571	152-0322-00			SEMICON D DEVICE: SILICON, 15V, HOT CARRIER	50434	5082-2672
CR573	152-0322-00			SEMICON D DEVICE: SILICON, 15V, HOT CARRIER	50434	5082-2672
CR595	152-0322-00			SEMICON D DEVICE: SILICON, 15V, HOT CARRIER	50434	5082-2672
CR597	152-0322-00			SEMICON D DEVICE: SILICON, 15V, HOT CARRIER	50434	5082-2672
CR601	152-0322-00			SEMICON D DEVICE: SILICON, 15V, HOT CARRIER	50434	5082-2672
CR603	152-0322-00			SEMICON D DEVICE: SILICON, 15V, HOT CARRIER	50434	5082-2672
CR625	152-0322-00			SEMICON D DEVICE: SILICON, 15V, HOT CARRIER	50434	5082-2672
CR627	152-0322-00			SEMICON D DEVICE: SILICON, 15V, HOT CARRIER	50434	5082-2672
CR631	152-0322-00			SEMICON D DEVICE: SILICON, 15V, HOT CARRIER	50434	5082-2672
CR633	152-0322-00			SEMICON D DEVICE: SILICON, 15V, HOT CARRIER	50434	5082-2672
CR650	152-0322-00			SEMICON D DEVICE: SILICON, 15V, HOT CARRIER	50434	5082-2672
CR652	152-0322-00			SEMICON D DEVICE: SILICON, 15V, HOT CARRIER	50434	5082-2672
CR670	152-0322-00			SEMICON D DEVICE: SILICON, 15V, HOT CARRIER	50434	5082-2672
CR672	152-0322-00			SEMICON D DEVICE: SILICON, 15V, HOT CARRIER	50434	5082-2672
CR690	152-0322-00			SEMICON D DEVICE: SILICON, 15V, HOT CARRIER	50434	5082-2672
CR692	152-0322-00			SEMICON D DEVICE: SILICON, 15V, HOT CARRIER	50434	5082-2672
CR700	152-0322-00			SEMICON D DEVICE: SILICON, 15V, HOT CARRIER	50434	5082-2672

Replaceable Electrical Parts—7L18 Service

Ckt No.	Tektronix Part No.	Serial/Model No. Eff	Dscont	Name & Description	Mfr Code	Mfr Part Number
CR702	152-0322-00			SEMICON D DEVICE:SILICON,15V,HOT CARRIER	50434	5082-2672
CR733	152-0322-00			SEMICON D DEVICE:SILICON,15V,HOT CARRIER	50434	5082-2672
CR735	152-0322-00			SEMICON D DEVICE:SILICON,15V,HOT CARRIER	50434	5082-2672
CR737	152-0322-00			SEMICON D DEVICE:SILICON,15V,HOT CARRIER	50434	5082-2672
CR739	152-0322-00			SEMICON D DEVICE:SILICON,15V,HOT CARRIER	50434	5082-2672
CR742	152-0141-02			SEMICON D DEVICE:SILICON,30V,150MA	01295	1N4152R
CR743	152-0141-02			SEMICON D DEVICE:SILICON,30V,150MA	01295	1N4152R
CR744	152-0141-02			SEMICON D DEVICE:SILICON,30V,150MA	01295	1N4152R
CR745	152-0141-02			SEMICON D DEVICE:SILICON,30V,150MA	01295	1N4152R
CR746	152-0141-02			SEMICON D DEVICE:SILICON,30V,150MA	01295	1N4152R
CR747	152-0141-02			SEMICON D DEVICE:SILICON,30V,150MA	01295	1N4152R
CR783	152-0141-02			SEMICON D DEVICE:SILICON,30V,150MA	01295	1N4152R
CR793	152-0141-02			SEMICON D DEVICE:SILICON,30V,150MA	01295	1N4152R
CR801	152-0141-02			SEMICON D DEVICE:SILICON,30V,150MA	01295	1N4152R
CR810	152-0322-00			SEMICON D DEVICE:SILICON,15V,HOT CARRIER	50434	5082-2672
CR813	152-0322-00			SEMICON D DEVICE:SILICON,15V,HOT CARRIER	50434	5082-2672
CR814	152-0322-00			SEMICON D DEVICE:SILICON,15V,HOT CARRIER	50434	5082-2672
CR818	152-0141-02			SEMICON D DEVICE:SILICON,30V,150MA	01295	1N4152R
CR819	152-0141-02	XB020400		SEMICON D DEVICE:SILICON,30V,150MA	01295	1N4152R
CR825	152-0141-02			SEMICON D DEVICE:SILICON,30V,150MA	01295	1N4152R
CR826	152-0141-02			SEMICON D DEVICE:SILICON,30V,150MA	01295	1N4152R
CR844	152-0141-02	XB020595		SEMICON D DEVICE:SILICON,30V,150MA	01295	1N4152R
CR846	152-0141-02	XB020595		SEMICON D DEVICE:SILICON,30V,150MA	01295	1N4152R
CR893	152-0141-02			SEMICON D DEVICE:SILICON,30V,150MA	01295	1N4152R
CR898	152-0141-02			SEMICON D DEVICE:SILICON,30V,150MA	01295	1N4152R
CR899	152-0141-02			SEMICON D DEVICE:SILICON,30V,150MA	01295	1N4152R
CR992	152-0322-00			SEMICON D DEVICE:SILICON,15V,HOT CARRIER	50434	5082-2672
CR994	152-0322-00			SEMICON D DEVICE:SILICON,15V,HOT CARRIER	50434	5082-2672
CR996	152-0322-00			SEMICON D DEVICE:SILICON,15V,HOT CARRIER	50434	5082-2672
CR998	152-0322-00			SEMICON D DEVICE:SILICON,15V,HOT CARRIER	50434	5082-2672
CR1014	152-0322-00			SEMICON D DEVICE:SILICON,15V,HOT CARRIER	50434	5082-2672
CR1024	152-0141-02			SEMICON D DEVICE:SILICON,30V,150MA	01295	1N4152R
CR1036	152-0141-02			SEMICON D DEVICE:SILICON,30V,150MA	01295	1N4152R
CR1068	152-0622-00			SEMICON D DEVICE:VVC,SI,15V,155PF	50101	V34-4203
CR1096	152-0322-00			SEMICON D DEVICE:SILICON,15V,HOT CARRIER	50434	5082-2672
CR1105	152-0141-02			SEMICON D DEVICE:SILICON,30V,150MA	01295	1N4152R
CR1151	-----	-----		(FURNISHED AS A UNIT WITH A940A7A2)		
CR1152	-----	-----		(FURNISHED AS A UNIT WITH A940A7A2)		
CR1153	152-0141-02			SEMICON D DEVICE:SILICON,30V,150MA	01295	1N4152R
CR1155	152-0322-00			SEMICON D DEVICE:SILICON,15V,HOT CARRIER	50434	5082-2672
CR1165	152-0322-00			SEMICON D DEVICE:SILICON,15V,HOT CARRIER	50434	5082-2672
CR1182	152-0141-02			SEMICON D DEVICE:SILICON,30V,150MA	01295	1N4152R
CR1187	152-0141-02			SEMICON D DEVICE:SILICON,30V,150MA	01295	1N4152R
CR1216	152-0141-02			SEMICON D DEVICE:SILICON,30V,150MA	01295	1N4152R
CR1231	152-0141-02			SEMICON D DEVICE:SILICON,30V,150MA	01295	1N4152R
CR1255	152-0141-02			SEMICON D DEVICE:SILICON,30V,150MA	01295	1N4152R
CR1260	152-0141-02			SEMICON D DEVICE:SILICON,30V,150MA	01295	1N4152R
CR1296	152-0141-02			SEMICON D DEVICE:SILICON,30V,150MA	01295	1N4152R
CR1298	152-0141-02			SEMICON D DEVICE:SILICON,30V,150MA	01295	1N4152R
CR1319	152-0141-02			SEMICON D DEVICE:SILICON,30V,150MA	01295	1N4152R
CR1320	152-0141-02			SEMICON D DEVICE:SILICON,30V,150MA	01295	1N4152R
CR1324	152-0141-02			SEMICON D DEVICE:SILICON,30V,150MA	01295	1N4152R
CR1329	152-0141-02			SEMICON D DEVICE:SILICON,30V,150MA	01295	1N4152R
CR1348	152-0141-02			SEMICON D DEVICE:SILICON,30V,150MA	01295	1N4152R
CR1349	152-0141-02			SEMICON D DEVICE:SILICON,30V,150MA	01295	1N4152R
CR1350	152-0141-02			SEMICON D DEVICE:SILICON,30V,150MA	01295	1N4152R
CR1351	152-0141-02			SEMICON D DEVICE:SILICON,30V,150MA	01295	1N4152R

Ckt No.	Tektronix Part No.	Serial/Model No. Eff	Dscont	Name & Description	Mfr Code	Mfr Part Number
CR1353	152-0141-02			SEMICON D DEVICE:SILICON,30V,150MA	01295	1N4152R
CR1354	152-0141-02			SEMICON D DEVICE:SILICON,30V,150MA	01295	1N4152R
CR1355	152-0141-02			SEMICON D DEVICE:SILICON,30V,150MA	01295	1N4152R
CR1360	152-0141-02			SEMICON D DEVICE:SILICON,30V,150MA	01295	1N4152R
CR1365	152-0141-02			SEMICON D DEVICE:SILICON,30V,150MA	01295	1N4152R
CR1370	152-0141-02			SEMICON D DEVICE:SILICON,30V,150MA	01295	1N4152R
CR1375	152-0141-02			SEMICON D DEVICE:SILICON,30V,150MA	01295	1N4152R
CR1390	152-0141-02			SEMICON D DEVICE:SILICON,30V,150MA	01295	1N4152R
CR1400	152-0141-02			SEMICON D DEVICE:SILICON,30V,150MA	01295	1N4152R
CR1401	152-0141-02			SEMICON D DEVICE:SILICON,30V,150MA	01295	1N4152R
CR1403	152-0141-02			SEMICON D DEVICE:SILICON,30V,150MA	01295	1N4152R
CR1421	152-0141-02			SEMICON D DEVICE:SILICON,30V,150MA	01295	1N4152R
CR1434	152-0141-02			SEMICON D DEVICE:SILICON,30V,150MA	01295	1N4152R
CR1435	152-0141-02			SEMICON D DEVICE:SILICON,30V,150MA	01295	1N4152R
CR1460	152-0141-02			SEMICON D DEVICE:SILICON,30V,150MA	01295	1N4152R
CR1466	152-0141-02			SEMICON D DEVICE:SILICON,30V,150MA	01295	1N4152R
CR1467	152-0075-00			SEMICON D DEVICE:GE,25V,40MA	14433	G866
CR1469	152-0075-00			SEMICON D DEVICE:GE,25V,40MA	14433	G866
CR1474	152-0141-02			SEMICON D DEVICE:SILICON,30V,150MA	01295	1N4152R
CR1480	152-0141-02			SEMICON D DEVICE:SILICON,30V,150MA	01295	1N4152R
CR1493	152-0141-02			SEMICON D DEVICE:SILICON,30V,150MA	01295	1N4152R
CR1494	152-0141-02			SEMICON D DEVICE:SILICON,30V,150MA	01295	1N4152R
CR1500	152-0141-02			SEMICON D DEVICE:SILICON,30V,150MA	01295	1N4152R
CR1516	152-0141-02			SEMICON D DEVICE:SILICON,30V,150MA	01295	1N4152R
CR1525	152-0075-00			SEMICON D DEVICE:GE,25V,40MA	14433	G866
CR1530	152-0141-02			SEMICON D DEVICE:SILICON,30V,150MA	01295	1N4152R
CR1545	152-0141-02			SEMICON D DEVICE:SILICON,30V,150MA	01295	1N4152R
CR1546	152-0141-02	XB010440		SEMICON D DEVICE:SILICON,30V,150MA	01295	1N4152R
CR1548	152-0141-02	XB010440		SEMICON D DEVICE:SILICON,30V,150MA	01295	1N4152R
CR1561	152-0141-02			SEMICON D DEVICE:SILICON,30V,150MA	01295	1N4152R
CR1585	152-0141-02			SEMICON D DEVICE:SILICON,30V,150MA	01295	1N4152R
CR1691	152-0141-02			SEMICON D DEVICE:SILICON,30V,150MA	01295	1N4152R
CR1693	152-0141-02			SEMICON D DEVICE:SILICON,30V,150MA	01295	1N4152R
CR1695	152-0141-02			SEMICON D DEVICE:SILICON,30V,150MA	01295	1N4152R
CR1697	152-0141-02			SEMICON D DEVICE:SILICON,30V,150MA	01295	1N4152R
CR1699	152-0141-02			SEMICON D DEVICE:SILICON,30V,150MA	01295	1N4152R
CR1701	152-0141-02			SEMICON D DEVICE:SILICON,30V,150MA	01295	1N4152R
CR1703	152-0141-02			SEMICON D DEVICE:SILICON,30V,150MA	01295	1N4152R
CR1705	152-0141-02			SEMICON D DEVICE:SILICON,30V,150MA	01295	1N4152R
CR1706	152-0141-02			SEMICON D DEVICE:SILICON,30V,150MA	01295	1N4152R
CR1707	152-0141-02			SEMICON D DEVICE:SILICON,30V,150MA	01295	1N4152R
CR1708	152-0141-02			SEMICON D DEVICE:SILICON,30V,150MA	01295	1N4152R
CR1749	152-0141-02			SEMICON D DEVICE:SILICON,30V,150MA	01295	1N4152R
CR1820	152-0141-02			SEMICON D DEVICE:SILICON,30V,150MA	01295	1N4152R
CR1821	152-0141-02			SEMICON D DEVICE:SILICON,30V,150MA	01295	1N4152R
CR1822	152-0141-02			SEMICON D DEVICE:SILICON,30V,150MA	01295	1N4152R
CR1823	152-0141-02			SEMICON D DEVICE:SILICON,30V,150MA	01295	1N4152R
CR1969	152-0075-00			SEMICON D DEVICE:GE,25V,40MA	14433	G866
CR1971	152-0075-00			SEMICON D DEVICE:GE,25V,40MA	14433	G866
CR2002	152-0141-02			SEMICON D DEVICE:SILICON,30V,150MA	01295	1N4152R
CR2004	152-0141-02			SEMICON D DEVICE:SILICON,30V,150MA	01295	1N4152R
CR2019	152-0075-00			SEMICON D DEVICE:GE,25V,40MA	14433	G866
CR2021	152-0075-00			SEMICON D DEVICE:GE,25V,40MA	14433	G866
CR2047	152-0141-02			SEMICON D DEVICE:SILICON,30V,150MA	01295	1N4152R
CR2065	152-0333-00			SEMICON D DEVICE:SILICON,55V,200MA	07263	FDH-6012
CR2067	152-0353-00			SEMICON D DEVICE:SILICON,RECT,800V,1W	05828	GP10K-014
CR2139	152-0141-02			SEMICON D DEVICE:SILICON,30V,150MA	01295	1N4152R

Replaceable Electrical Parts—7L18 Service

Ckt No.	Tektronix Part No.	Serial/Model No. Eff	Dscont	Name & Description	Mfr Code	Mfr Part Number
CR2156	152-0141-02			SEMICON D DEVICE:SILICON,30V,150MA	01295	1N4152R
CR2158	152-0141-02			SEMICON D DEVICE:SILICON,30V,150MA	01295	1N4152R
CR2193	152-0333-00			SEMICON D DEVICE:SILICON,55V,200MA	07263	FDH-6012
CR2197	152-0353-00			SEMICON D DEVICE:SILICON,RECT,800V,1W	05828	GP10K-014
CR2251	152-0141-02			SEMICON D DEVICE:SILICON,30V,150MA	01295	1N4152R
CR2263	152-0141-02			SEMICON D DEVICE:SILICON,30V,150MA	01295	1N4152R
CR2265	152-0141-02			SEMICON D DEVICE:SILICON,30V,150MA	01295	1N4152R
CR2280	152-0141-02			SEMICON D DEVICE:SILICON,30V,150MA	01295	1N4152R
CR2282	152-0066-00			SEMICON D DEVICE:SILICON,400V,750MA	14433	LG4016
CR2283	152-0141-02			SEMICON D DEVICE:SILICON,30V,150MA	01295	1N4152R
CR2330	152-0141-02			SEMICON D DEVICE:SILICON,30V,150MA	01295	1N4152R
CR2331	152-0141-02			SEMICON D DEVICE:SILICON,30V,150MA	01295	1N4152R
CR2350	152-0141-02			SEMICON D DEVICE:SILICON,30V,150MA	01295	1N4152R
CR2351	152-0141-02			SEMICON D DEVICE:SILICON,30V,150MA	01295	1N4152R
CR2399	152-0579-00			SEMICON D DEVICE:SILICON,100V,2.5A	12969	UM6601B
CR2407	152-0579-00			SEMICON D DEVICE:SILICON,100V,2.5A	12969	UM6601B
CR2459	152-0322-00			SEMICON D DEVICE:SILICON,15V,HOT CARRIER	50434	5082-2672
CR2461	152-0322-00			SEMICON D DEVICE:SILICON,15V,HOT CARRIER	50434	5082-2672
CR2472	152-0322-00			SEMICON D DEVICE:SILICON,15V,HOT CARRIER	50434	5082-2672
CR2474	152-0322-00			SEMICON D DEVICE:SILICON,15V,HOT CARRIER	50434	5082-2672
CR2508	152-0075-00			SEMICON D DEVICE:GE,25V,40MA	14433	G866
CR2585	152-0141-02			SEMICON D DEVICE:SILICON,30V,150MA	01295	1N4152R
CR2626	152-0141-02			SEMICON D DEVICE:SILICON,30V,150MA	01295	1N4152R
CR2636	152-0141-02			SEMICON D DEVICE:SILICON,30V,150MA	01295	1N4152R
CR2746	152-0579-00			SEMICON D DEVICE:SILICON,100V,2.5A	12969	UM6601B
CR2752	152-0579-00			SEMICON D DEVICE:SILICON,100V,2.5A	12969	UM6601B
CR2778	152-0579-00			SEMICON D DEVICE:SILICON,100V,2.5A	12969	UM6601B
CR2780	152-0579-00			SEMICON D DEVICE:SILICON,100V,2.5A	12969	UM6601B
CR2870	152-0141-02	B010100	B020399X	SEMICON D DEVICE:SILICON,30V,150MA	01295	1N4152R
CR2880	152-0066-00			SEMICON D DEVICE:SILICON,400V,750MA	14433	LG4016
CR2882	152-0066-00			SEMICON D DEVICE:SILICON,400V,750MA	14433	LG4016
CR2884	152-0066-00			SEMICON D DEVICE:SILICON,400V,750MA	14433	LG4016
CR2886	152-0066-00			SEMICON D DEVICE:SILICON,400V,750MA	14433	LG4016
CR2888	152-0066-00			SEMICON D DEVICE:SILICON,400V,750MA	14433	LG4016
CR2894	152-0066-00			SEMICON D DEVICE:SILICON,400V,750MA	14433	LG4016
CR2900	-----			(FURNISHED AS A UNIT WITH 672-0589-00)		
CR2901	-----			(FURNISHED AS A UNIT WITH 672-0589-00)		
CR2902	-----			(FURNISHED AS A UNIT WITH 672-0589-00)		
CR2903	-----			(FURNISHED AS A UNIT WITH 672-0589-00)		
CR2904	-----			(FURNISHED AS A UNIT WITH 672-0589-00)		
CR2905	-----			(FURNISHED AS A UNIT WITH 672-0589-00)		
CR2906	-----			(FURNISHED AS A UNIT WITH 672-0589-00)		
CR2990	152-0066-00			SEMICON D DEVICE:SILICON,400V,750MA	14433	LG4016
CR2992	152-0066-00			SEMICON D DEVICE:SILICON,400V,750MA	14433	LG4016
CR3004	152-0141-02			SEMICON D DEVICE:SILICON,30V,150MA	01295	1N4152R
CR3010	152-0524-00			SEMICON D DEVICE:SILICON,100V,100MA	80009	152-0524-00
CR3018	152-0141-02			SEMICON D DEVICE:SILICON,30V,150MA	01295	1N4152R
CR3022	152-0141-02			SEMICON D DEVICE:SILICON,30V,150MA	01295	1N4152R
CR3076	152-0141-02			SEMICON D DEVICE:SILICON,30V,150MA	01295	1N4152R
CR3092	152-0141-02			SEMICON D DEVICE:SILICON,30V,150MA	01295	1N4152R
CR3140	152-0153-00	B010100	B020624X	SEMICON D DEVICE:SILICON,15V,50MA	07263	FD7003
CR3142	152-0153-00	B010100	B020624X	SEMICON D DEVICE:SILICON,15V,50MA	07263	FD7003
CR3144	152-0153-00	B010100	B020624X	SEMICON D DEVICE:SILICON,15V,50MA	07263	FD7003
CR3146	152-0153-00	B010100	B020624X	SEMICON D DEVICE:SILICON,15V,50MA	07263	FD7003
CR3148	152-0107-04	B010100	B020664	SEMICON D DEVICE:SILICON,400V,400MA,SEL	14936	GPD-011
CR3148	152-0728-00	B020665		SEMICON D DEVICE:SILICON,PIN SWITCH	80009	152-0728-00
CR3150	152-0107-04	B010100	B020664	SEMICON D DEVICE:SILICON,400V,400MA,SEL	14936	GPD-011
CR3150	152-0728-00	B020665		SEMICON D DEVICE:SILICON,PIN SWITCH	80009	152-0728-00

Ckt No.	Tektronix Part No.	Serial/Model No. Eff	Dscont	Name & Description	Mfr Code	Mfr Part Number
CR3152	152-0107-04	B010100	B020664	SEMICON D DEVICE: SILICON, 400V, 400MA, SEL	14936	GPD-011
CR3152	152-0728-00	B020665		SEMICON D DEVICE: SILICON, PIN SWITCH	80009	152-0728-00
CR3154	152-0107-04	B010100	B020664	SEMICON D DEVICE: SILICON, 400V, 400MA, SEL	14936	GPD-011
CR3154	152-0728-00	B020665		SEMICON D DEVICE: SILICON, PIN SWITCH	80009	152-0728-00
CR3156	152-0107-04	B010100	B020664	SEMICON D DEVICE: SILICON, 400V, 400MA, SEL	14936	GPD-011
CR3156	152-0728-00	B020665		SEMICON D DEVICE: SILICON, PIN SWITCH	80009	152-0728-00
CR3158	152-0107-04	B010100	B020664	SEMICON D DEVICE: SILICON, 400V, 400MA, SEL	14936	GPD-011
CR3158	152-0728-00	B020665		SEMICON D DEVICE: SILICON, PIN SWITCH	80009	152-0728-00
CR3170	152-0107-04	B010100	B020664	SEMICON D DEVICE: SILICON, 400V, 400MA, SEL	14936	GPD-011
CR3170	152-0728-00	B020665		SEMICON D DEVICE: SILICON, PIN SWITCH	80009	152-0728-00
CR3172	152-0107-04	B010100	B020664	SEMICON D DEVICE: SILICON, 400V, 400MA, SEL	14936	GPD-011
CR3172	152-0728-00	B020665		SEMICON D DEVICE: SILICON, PIN SWITCH	80009	152-0728-00
CR3174	152-0107-04	B010100	B020664	SEMICON D DEVICE: SILICON, 400V, 400MA, SEL	14936	GPD-011
CR3174	152-0728-00	B020665		SEMICON D DEVICE: SILICON, PIN SWITCH	80009	152-0728-00
CR3176	152-0107-04	B010100	B020664	SEMICON D DEVICE: SILICON, 400V, 400MA, SEL	14936	GPD-011
CR3176	152-0728-00	B020665		SEMICON D DEVICE: SILICON, PIN SWITCH	80009	152-0728-00
CR3178	152-0107-04	B010100	B020664	SEMICON D DEVICE: SILICON, 400V, 400MA, SEL	14936	GPD-011
CR3178	152-0728-00	B020665		SEMICON D DEVICE: SILICON, PIN SWITCH	80009	152-0728-00
CR3179	152-0107-04	B010100	B020664	SEMICON D DEVICE: SILICON, 400V, 400MA, SEL	14936	GPD-011
CR3179	152-0728-00	B020665		SEMICON D DEVICE: SILICON, PIN SWITCH	80009	152-0728-00
CR3212	152-0107-04			SEMICON D DEVICE: SILICON, 400V, 400MA, SEL	14936	GPD-011
CR3214	152-0107-04			SEMICON D DEVICE: SILICON, 400V, 400MA, SEL	14936	GPD-011
CR3216	152-0107-04			SEMICON D DEVICE: SILICON, 400V, 400MA, SEL	14936	GPD-011
CR3218	152-0107-04			SEMICON D DEVICE: SILICON, 400V, 400MA, SEL	14936	GPD-011
CR3224	152-0107-04			SEMICON D DEVICE: SILICON, 400V, 400MA, SEL	14936	GPD-011
CR3226	152-0107-04			SEMICON D DEVICE: SILICON, 400V, 400MA, SEL	14936	GPD-011
CR3238	152-0107-04			SEMICON D DEVICE: SILICON, 400V, 400MA, SEL	14936	GPD-011
CR3240	152-0107-04			SEMICON D DEVICE: SILICON, 400V, 400MA, SEL	14936	GPD-011
CR3242	152-0107-04			SEMICON D DEVICE: SILICON, 400V, 400MA, SEL	14936	GPD-011
CR3248	152-0107-04			SEMICON D DEVICE: SILICON, 400V, 400MA, SEL	14936	GPD-011
CR3250	152-0107-04			SEMICON D DEVICE: SILICON, 400V, 400MA, SEL	14936	GPD-011
CR3252	152-0107-04			SEMICON D DEVICE: SILICON, 400V, 400MA, SEL	14936	GPD-011
CR3272	152-0524-00			SEMICON D DEVICE: SILICON, 100V, 100MA	80009	152-0524-00
CR3360	152-0141-02			SEMICON D DEVICE: SILICON, 30V, 150MA	01295	1N4152R
CR3362	152-0141-02			SEMICON D DEVICE: SILICON, 30V, 150MA	01295	1N4152R
CR3364	152-0141-02			SEMICON D DEVICE: SILICON, 30V, 150MA	01295	1N4152R
CR3424	152-0141-02			SEMICON D DEVICE: SILICON, 30V, 150MA	01295	1N4152R
CR3426	152-0141-02			SEMICON D DEVICE: SILICON, 30V, 150MA	01295	1N4152R
CR3427	152-0141-02			SEMICON D DEVICE: SILICON, 30V, 150MA	01295	1N4152R
CR3440	152-0141-02			SEMICON D DEVICE: SILICON, 30V, 150MA	01295	1N4152R
CR3443	152-0141-02			SEMICON D DEVICE: SILICON, 30V, 150MA	01295	1N4152R
CR3444	152-0141-02			SEMICON D DEVICE: SILICON, 30V, 150MA	01295	1N4152R
CR3557	152-0141-02			SEMICON D DEVICE: SILICON, 30V, 150MA	01295	1N4152R
CR3559	152-0141-02			SEMICON D DEVICE: SILICON, 30V, 150MA	01295	1N4152R
DS105	150-1011-03			LAMP, LED RDOUT: RED, 7 SEG, 1.0DIGIT, SEL	80009	150-1011-03
DS110	150-1011-03			LAMP, LED RDOUT: RED, 7 SEG, 1.0DIGIT, SEL	80009	150-1011-03
DS115	150-1011-03			LAMP, LED RDOUT: RED, 7 SEG, 1.0DIGIT, SEL	80009	150-1011-03
DS120	150-1011-03			LAMP, LED RDOUT: RED, 7 SEG, 1.0DIGIT, SEL	80009	150-1011-03
DS125	150-1011-03			LAMP, LED RDOUT: RED, 7 SEG, 1.0DIGIT, SEL	80009	150-1011-03
DS130	150-1031-00			LT EMITTING DIO: RED, 650NM, 40MA MAX	53184	XC209R
DS132	150-1031-00			LT EMITTING DIO: RED, 650NM, 40MA MAX	53184	XC209R
DS138	150-1050-00	B010100	B020449	LT EMITTING DIO: RED	50579	RL-T1
DS138	150-1068-00	B020450		LT EMITTING DIO: RED	50434	HLMP-6320
DS140	150-1050-00	B010100	B020449	LT EMITTING DIO: RED	50579	RL-T1
DS140	150-1068-00	B020450		LT EMITTING DIO: RED	50434	HLMP-6320
DS144	150-1050-00	B010100	B020449	LT EMITTING DIO: RED	50579	RL-T1

Replaceable Electrical Parts—7L18 Service

Ckt No.	Tektronix Part No.	Serial/Model No. Eff	Dscont	Name & Description	Mfr Code	Mfr Part Number
DS144	150-1068-00	B020450		LT EMITTING DIO:RED	50434	HLMP-6320
DS146	150-1050-00	B010100	B020449	LT EMITTING DIO:RED	50579	RL-T1
DS146	150-1068-00	B020450		LT EMITTING DIO:RED	50434	HLMP-6320
DS150	150-1050-00	B010100	B020449	LT EMITTING DIO:RED	50579	RL-T1
DS150	150-1068-00	B020450		LT EMITTING DIO:RED	50434	HLMP-6320
DS154	150-1050-00	B010100	B020449	LT EMITTING DIO:RED	50579	RL-T1
DS154	150-1068-00	B020450		LT EMITTING DIO:RED	50434	HLMP-6320
DS162	150-1050-00	B010100	B020449	LT EMITTING DIO:RED	50579	RL-T1
DS162	150-1068-00	B020450		LT EMITTING DIO:RED	50434	HLMP-6320
DS164	150-1050-00	B010100	B020449	LT EMITTING DIO:RED	50579	RL-T1
DS164	150-1068-00	B020450		LT EMITTING DIO:RED	50434	HLMP-6320
DS166	150-1050-00	B010100	B020449	LT EMITTING DIO:RED	50579	RL-T1
DS166	150-1068-00	B020450		LT EMITTING DIO:RED	50434	HLMP-6320
DS168	150-1050-00	B010100	B020449	LT EMITTING DIO:RED	50579	RL-T1
DS168	150-1068-00	B020450		LT EMITTING DIO:RED	50434	HLMP-6320
DS170	150-1031-00			LT EMITTING DIO:RED,650NM,40MA MAX	53184	XC209R
DS178	150-1050-00	B010100	B020449	LT EMITTING DIO:RED	50579	RL-T1
DS178	150-1068-00	B020450		LT EMITTING DIO:RED	50434	HLMP-6320
DS180	150-1050-00	B010100	B020449	LT EMITTING DIO:RED	50579	RL-T1
DS180	150-1068-00	B020450		LT EMITTING DIO:RED	50434	HLMP-6320
DS182	150-1050-00	B010100	B020449	LT EMITTING DIO:RED	50579	RL-T1
DS182	150-1068-00	B020450		LT EMITTING DIO:RED	50434	HLMP-6320
DS184	150-1050-00	B010100	B020449	LT EMITTING DIO:RED	50579	RL-T1
DS184	150-1068-00	B020450		LT EMITTING DIO:RED	50434	HLMP-6320
DS186	150-1050-00	B010100	B020449	LT EMITTING DIO:RED	50579	RL-T1
DS186	150-1068-00	B020450		LT EMITTING DIO:RED	50434	HLMP-6320
DS188	150-1050-00	B010100	B020449	LT EMITTING DIO:RED	50579	RL-T1
DS188	150-1068-00	B020450		LT EMITTING DIO:RED	50434	HLMP-6320
DS190	150-1050-00	B010100	B020449	LT EMITTING DIO:RED	50579	RL-T1
DS190	150-1068-00	B020450		LT EMITTING DIO:RED	50434	HLMP-6320
DS2650	150-1012-05	B010105	B020399	LAMP,LED RDOU:RED,7 SEG,4.0 DIGIT,SEL	80009	150-1012-05
DS2650	150-1012-06	B020400		LAMP,LED RDOU:RED,7 SEG,4.0DIGIT W/FR	80009	150-1012-06
DS2658	150-1033-00			LT EMITTING DIO:YELLOW,585NM,40MA MAX	50434	5082-4584
E3050	276-0543-00	XB010140		SHLD BEAD,ELEK:FERRITE	80009	276-0543-00
FL30	119-0791-00			FILTER,BANDPASS:510MHZ	80009	119-0791-00
F2102	159-0094-00			FUSE,WIRE LEAD:32V,0.75A.FAST BLOW	75915	273-750
F2217	159-0094-00			FUSE,WIRE LEAD:32V,0.75A.FAST BLOW	75915	273-750
K1155	148-0064-00			RELAY,REED:SPST	95348	CB-831A-26
K1255	148-0064-00			RELAY,REED:SPST	95348	CB-831A-26
K1330	148-0064-00			RELAY,REED:SPST	95348	CB-831A-26
K1355	148-0064-00			RELAY,REED:SPST	95348	CB-831A-26
K1360	148-0064-00			RELAY,REED:SPST	95348	CB-831A-26
K1365	148-0064-00			RELAY,REED:SPST	95348	CB-831A-26
K1370	148-0064-00			RELAY,REED:SPST	95348	CB-831A-26
K2251	148-0064-00			RELAY,REED:SPST	95348	CB-831A-26
K2286	148-0076-00			RELAY,REED:1 FORM A,5V,0.25A,100V	95348	F81-1447
K3076	148-0107-01			RELAY,ARMATURE:18VDC COIL	80009	148-0107-01
K3076S1	148-0107-01			RELAY,ARMATURE:18VDC COIL	80009	148-0107-01
K3076S2	148-0107-01			RELAY,ARMATURE:18VDC COIL	80009	148-0107-01
L90	108-0422-00			COIL,RF:FIXED,82UH	80009	108-0422-00
L100	108-0395-00	B010100	B010149X	COIL,RF:64UH	80009	108-0395-00
L102	108-0395-00	B010100	B010149X	COIL,RF:64UH	80009	108-0395-00
L202	108-0395-00			COIL,RF:64UH	80009	108-0395-00
L204	108-0395-00			COIL,RF:64UH	80009	108-0395-00
L254	108-0395-00			COIL,RF:64UH	80009	108-0395-00

Replaceable Electrical Parts—7L18 Service

Ckt No.	Tektronix Part No.	Serial/Model No. Eff	Dscont	Name & Description	Mfr Code	Mfr Part Number
L258	108-0395-00			COIL, RF: 64UH	80009	108-0395-00
L338	108-0226-00			COIL, RF: 100UH	76493	DWG B4257
L490	108-0598-00			COIL, RF: 200UH	80009	108-0598-00
L494	108-0598-00			COIL, RF: 200UH	80009	108-0598-00
L496	108-0598-00			COIL, RF: 200UH	80009	108-0598-00
L583	108-0872-00			COIL, RF: FIXED, 30.3UH	80009	108-0872-00
L617	108-0872-00			COIL, RF: FIXED, 30.3UH	80009	108-0872-00
L639	108-0395-00			COIL, RF: 64UH	80009	108-0395-00
L645	108-0395-00			COIL, RF: 64UH	80009	108-0395-00
L647	108-0872-00			COIL, RF: FIXED, 30.3UH	80009	108-0872-00
L667	108-0872-00			COIL, RF: FIXED, 30.3UH	80009	108-0872-00
L687	108-0872-00			COIL, RF: FIXED, 30.3UH	80009	108-0872-00
L698	108-0872-00			COIL, RF: FIXED, 30.3UH	80009	108-0872-00
L761	108-0702-00			COIL, RF: 36UH	80009	108-0702-00
L767	108-0443-00			COIL, RF: 25UH	80009	108-0443-00
L992	108-0170-01			COIL, RF: FIXED, 360NH	80009	108-0170-01
L994	108-0231-00			COIL, RF: 4.5UH	80009	108-0231-00
L1002	108-0231-00			COIL, RF: 4.5UH	80009	108-0231-00
L1012	108-0551-00			COIL, RF: 14UH	80009	108-0551-00
L1028	108-0551-00			COIL, RF: 14UH	80009	108-0551-00
L1054	108-0395-00			COIL, RF: 64UH	80009	108-0395-00
L1056	108-0395-00			COIL, RF: 64UH	80009	108-0395-00
L1057	108-0395-00			COIL, RF: 64UH	80009	108-0395-00
L1070	108-0174-00			COIL, RF: 245UH	80009	108-0174-00
L1080	-----			(FURNISHED AS A UNIT WITH A940A5)		
L1086	-----			(FURNISHED AS A UNIT WITH A940A5)		
L1100	108-0395-00			COIL, RF: 64UH	80009	108-0395-00
L1122	108-0551-00			COIL, RF: 14UH	80009	108-0551-00
L1158	108-0887-00			COIL, RF: FIXED, 23.6UH	80009	108-0887-00
L1168	108-0551-00			COIL, RF: 14UH	80009	108-0551-00
L1271	108-0551-00			COIL, RF: 14UH	80009	108-0551-00
L1278	108-0551-00			COIL, RF: 14UH	80009	108-0551-00
L1501	108-0395-00			COIL, RF: 64UH	80009	108-0395-00
L2305	108-0597-00			COIL, RF: TOROIDAL, 425UH	80009	108-0597-00
L2307	108-0881-00			COIL, RF: FIXED, 40.1UH	80009	108-0881-00
L2311	108-0597-00			COIL, RF: TOROIDAL, 425UH	80009	108-0597-00
L2313	108-0881-00			COIL, RF: FIXED, 40.1UH	80009	108-0881-00
L2315	108-0598-00			COIL, RF: 200UH	80009	108-0598-00
L2360	108-0551-00			COIL, RF: 14UH	80009	108-0551-00
L2364	108-0551-00			COIL, RF: 14UH	80009	108-0551-00
L2380	108-0870-00			COIL, RF: FIXED, 44NH	80009	108-0870-00
L2448	108-0550-00			COIL, RF: 110NH	80009	108-0550-00
L2450	108-0869-00			COIL, RF: FIXED, 23NH	80009	108-0869-00
L2458	108-0869-00			COIL, RF: FIXED, 23NH	80009	108-0869-00
L2474	108-0870-00			COIL, RF: FIXED, 44NH	80009	108-0870-00
L2482	108-0181-01			COIL, RF: 0.2UH	80009	108-0181-01
L2484	108-0262-00			COIL, RF: FIXED, 510MH	80009	108-0262-00
L2690	108-0551-00			COIL, RF: 14UH	80009	108-0551-00
L2800	108-0871-00			COIL, RF: FIXED, 60NH	80009	108-0871-00
L2814	108-0869-00			COIL, RF: FIXED, 23NH	80009	108-0869-00
L2818	108-0551-00			COIL, RF: 14UH	80009	108-0551-00
L2820	108-0869-00			COIL, RF: FIXED, 23NH	80009	108-0869-00
L2824	108-0871-00			COIL, RF: FIXED, 60NH	80009	108-0871-00
L2880	108-0422-00			COIL, RF: FIXED, 82UH	80009	108-0422-00
L2894	108-0422-00			COIL, RF: FIXED, 82UH	80009	108-0422-00
L3102	108-0226-00			COIL, RF: 100UH	76493	DWG B4257
L3192	108-0701-00			COIL, RF: 1.3UH	80009	108-0701-00

Replaceable Electrical Parts—7L18 Service

Ckt No.	Tektronix Part No.	Serial/Model No. Eff	Dscont	Name & Description	Mfr Code	Mfr Part Number
L3196	108-0701-00			COIL,RF:1.3UH	80009	108-0701-00
L3200	108-0701-00			COIL,RF:1.3UH	80009	108-0701-00
L3300	108-0395-00			COIL,RF:64UH	80009	108-0395-00
L3302	108-0395-00			COIL,RF:64UH	80009	108-0395-00
L3304	108-0395-00			COIL,RF:64UH	80009	108-0395-00
L3306	108-0395-00			COIL,RF:64UH	80009	108-0395-00
L3420	108-0226-00			COIL,RF:100UH	76493	DWG B4257
L3424	108-0317-00			COIL,RF:FIXED,15UH	32159	71501M
L3426	108-0701-00			COIL,RF:1.3UH	80009	108-0701-00
L3432	108-0317-00			COIL,RF:FIXED,15UH	32159	71501M
L3436	108-0701-00			COIL,RF:1.3UH	80009	108-0701-00
L3440	108-0317-00			COIL,RF:FIXED,15UH	32159	71501M
L3446	108-0701-00			COIL,RF:1.3UH	80009	108-0701-00
L3450	108-0317-00			COIL,RF:FIXED,15UH	32159	71501M
L3452	108-0436-00	B010100	B010109	COIL,RF:FIXED,240NH	80009	108-0436-00
L3452	108-0182-00	B010110		COIL,RF:0.3UH	80009	108-0182-00
L3454	108-0231-00			COIL,RF:4.5UH	80009	108-0231-00
L3457	108-0436-00			COIL,RF:FIXED,240NH	80009	108-0436-00
L3459	108-0736-00			COIL,RF:810NH	80009	108-0736-00
L3462	108-0395-00			COIL,RF:64UH	80009	108-0395-00
L3466	108-0395-00			COIL,RF:64UH	80009	108-0395-00
L3480	108-0551-00			COIL,RF:14UH	80009	108-0551-00
L3552	108-0598-00			COIL,RF:200UH	80009	108-0598-00
L3553	108-0598-00			COIL,RF:200UH	80009	108-0598-00
L3554	108-0598-00			COIL,RF:200UH	80009	108-0598-00
M2896	149-0030-00	B010100	B020533	METER,T TOTAL:ELAPSED TIME,DC,CKT BD MT	18583	21985-000
M2896	149-0046-01	B020534		METER,T TOTAL:500 HRS,55-700 VDC	80009	149-0046-01
Q105	151-0281-00			TRANSISTOR:SILICON,NPN	03508	X16P4039
Q110	151-0281-00			TRANSISTOR:SILICON,NPN	03508	X16P4039
Q115	151-0281-00			TRANSISTOR:SILICON,NPN	03508	X16P4039
Q120	151-0281-00			TRANSISTOR:SILICON,NPN	03508	X16P4039
Q125	151-0281-00			TRANSISTOR:SILICON,NPN	03508	X16P4039
Q130	151-0188-00			TRANSISTOR:SILICON,PNP	04713	SPS6868K
Q210	151-0190-00			TRANSISTOR:SILICON,NPN	07263	S032677
Q320	151-0405-00			TRANSISTOR:SILICON,NPN,SEL FROM MJE800	04713	SJE943
Q345	151-0190-00			TRANSISTOR:SILICON,NPN	07263	S032677
Q460	151-1005-00			TRANSISTOR:SILICON,JFE,N-CHANNEL	80009	151-1005-00
Q495	151-0190-00			TRANSISTOR:SILICON,NPN	07263	S032677
Q497	151-0188-00			TRANSISTOR:SILICON,PNP	04713	SPS6868K
Q530	151-0190-00			TRANSISTOR:SILICON,NPN	07263	S032677
Q535	151-0190-00			TRANSISTOR:SILICON,NPN	07263	S032677
Q538	151-0188-00			TRANSISTOR:SILICON,PNP	04713	SPS6868K
Q555	151-0190-00			TRANSISTOR:SILICON,NPN	07263	S032677
Q560	151-0190-00			TRANSISTOR:SILICON,NPN	07263	S032677
Q585	151-0190-00			TRANSISTOR:SILICON,NPN	07263	S032677
Q590	151-0190-00			TRANSISTOR:SILICON,NPN	07263	S032677
Q615	151-0190-00			TRANSISTOR:SILICON,NPN	07263	S032677
Q620	151-0190-00			TRANSISTOR:SILICON,NPN	07263	S032677
Q635	151-0190-00			TRANSISTOR:SILICON,NPN	07263	S032677
Q650	151-0190-00			TRANSISTOR:SILICON,NPN	07263	S032677
Q655	151-0190-00			TRANSISTOR:SILICON,NPN	07263	S032677
Q670	151-0190-00			TRANSISTOR:SILICON,NPN	07263	S032677
Q685	151-0190-00			TRANSISTOR:SILICON,NPN	07263	S032677
Q690	151-0190-00			TRANSISTOR:SILICON,NPN	07263	S032677
Q695	151-0190-00			TRANSISTOR:SILICON,NPN	07263	S032677
Q700	151-0190-00			TRANSISTOR:SILICON,NPN	07263	S032677

Ckt No.	Tektronix Part No.	Serial/Model No. Eff	Dscont	Name & Description	Mfr Code	Mfr Part Number
Q710	151-0190-00			TRANSISTOR:SILICON,NPN	07263	S032677
Q730	151-0192-00			TRANSISTOR:SILICON,NPN,SEL FROM MPS6521	04713	SPS8801
Q735	151-0221-00			TRANSISTOR:SILICON,PNP	04713	SPS246
Q750	151-0221-00			TRANSISTOR:SILICON,PNP	04713	SPS246
Q790	151-0190-00			TRANSISTOR:SILICON,NPN	07263	S032677
Q800	151-1006-00			TRANSISTOR:SILICON,JFE,N-CHANNEL	80009	151-1006-00
Q810	151-1006-00			TRANSISTOR:SILICON,JFE,N-CHANNEL	80009	151-1006-00
Q818	151-0435-00	B010100	B020399	TRANSISTOR:SILICON,PNP	04713	SPS8335
Q818	151-0221-00	B020400		TRANSISTOR:SILICON,PNP	04713	SPS246
Q840	151-0190-00			TRANSISTOR:SILICON,NPN	07263	S032677
Q850	151-0190-00			TRANSISTOR:SILICON,NPN	07263	S032677
Q855	151-0190-00			TRANSISTOR:SILICON,NPN	07263	S032677
Q860	151-0188-00			TRANSISTOR:SILICON,PNP	04713	SPS6868K
Q870	151-0188-00			TRANSISTOR:SILICON,PNP	04713	SPS6868K
Q875	151-0188-00			TRANSISTOR:SILICON,PNP	04713	SPS6868K
Q880	151-0190-00			TRANSISTOR:SILICON,NPN	07263	S032677
Q940	151-0367-00			TRANSISTOR:SILICON,NPN,SEL FROM 3571TP	01295	SKA6516
Q945	151-0442-00			TRANSISTOR:SILICON,NPN	80009	151-0442-00
Q950	151-0442-00			TRANSISTOR:SILICON,NPN	80009	151-0442-00
Q955	151-0442-00			TRANSISTOR:SILICON,NPN	80009	151-0442-00
Q959	151-1097-00	XB020385		TRANSISTOR:SILICON,FE	04713	SPF713
Q960	151-0367-00			TRANSISTOR:SILICON,NPN,SEL FROM 3571TP	01295	SKA6516
Q963	151-1097-00	XB020385		TRANSISTOR:SILICON,FE	04713	SPF713
Q964	151-1097-00	XB020385		TRANSISTOR:SILICON,FE	04713	SPF713
Q965	151-0190-00			TRANSISTOR:SILICON,NPN	07263	S032677
Q967	151-1097-00	XB020385		TRANSISTOR:SILICON,FE	04713	SPF713
Q970	151-0190-00			TRANSISTOR:SILICON,NPN	07263	S032677
Q975	151-0442-00			TRANSISTOR:SILICON,NPN	80009	151-0442-00
Q980	151-0190-00			TRANSISTOR:SILICON,NPN	07263	S032677
Q985	151-0190-00			TRANSISTOR:SILICON,NPN	07263	S032677
Q1000	151-0190-00			TRANSISTOR:SILICON,NPN	07263	S032677
Q1005	151-0190-00			TRANSISTOR:SILICON,NPN	07263	S032677
Q1010	151-0442-00			TRANSISTOR:SILICON,NPN	80009	151-0442-00
Q1030	151-0190-00			TRANSISTOR:SILICON,NPN	07263	S032677
Q1040	151-0188-00			TRANSISTOR:SILICON,PNP	04713	SPS6868K
Q1050	151-0188-00			TRANSISTOR:SILICON,PNP	04713	SPS6868K
Q1055	151-0188-00			TRANSISTOR:SILICON,PNP	04713	SPS6868K
Q1060	151-0190-00			TRANSISTOR:SILICON,NPN	07263	S032677
Q1065	151-0190-00			TRANSISTOR:SILICON,NPN	07263	S032677
Q1090	151-0442-00			TRANSISTOR:SILICON,NPN	80009	151-0442-00
Q1095	151-0442-00			TRANSISTOR:SILICON,NPN	80009	151-0442-00
Q1100	151-0327-00			TRANSISTOR:SILICON,PNP	80009	151-0327-00
Q1145	151-1021-00			TRANSISTOR:SILICON,JFE	17856	FN815
Q1150	151-0327-00			TRANSISTOR:SILICON,PNP	80009	151-0327-00
Q1155	151-1012-00			TRANSISTOR:SILICON,FE,N-CHANNEL	80009	151-1012-00
Q1165	151-0442-00			TRANSISTOR:SILICON,NPN	80009	151-0442-00
Q1170	151-0188-00			TRANSISTOR:SILICON,PNP	04713	SPS6868K
Q1180	151-0190-00			TRANSISTOR:SILICON,NPN	07263	S032677
Q1190	151-1066-00			TRANSISTOR:SILICON,FE,P-CHANNEL	80009	151-1066-00
Q1215	151-1066-00			TRANSISTOR:SILICON,FE,P-CHANNEL	80009	151-1066-00
Q1230	151-0190-00			TRANSISTOR:SILICON,NPN	07263	S032677
Q1255	151-0342-00			TRANSISTOR:SILICON,PNP	07263	S035928
Q1260	151-1066-00			TRANSISTOR:SILICON,FE,P-CHANNEL	80009	151-1066-00
Q1280	151-0432-00			TRANSISTOR:SILICON,NPN	80009	151-0432-00
Q1320	151-0190-00			TRANSISTOR:SILICON,NPN	07263	S032677
Q1325	151-0190-00			TRANSISTOR:SILICON,NPN	07263	S032677
Q1330	151-0190-00			TRANSISTOR:SILICON,NPN	07263	S032677

Replaceable Electrical Parts—7L18 Service

Ckt No.	Tektronix Part No.	Serial/Model No. Eff	Dscont	Name & Description	Mfr Code	Mfr Part Number
Q1335	151-0190-00			TRANSISTOR: SILICON, NPN	07263	S032677
Q1340	151-0190-00			TRANSISTOR: SILICON, NPN	07263	S032677
Q1345	151-0190-00			TRANSISTOR: SILICON, NPN	07263	S032677
Q1350	151-0190-00			TRANSISTOR: SILICON, NPN	07263	S032677
Q1355	151-0190-00			TRANSISTOR: SILICON, NPN	07263	S032677
Q1359	151-0391-00			TRANSISTOR: SILICON, PNP	80009	151-0391-00
Q1360	151-0190-00			TRANSISTOR: SILICON, NPN	07263	S032677
Q1363	151-0390-00			TRANSISTOR: SILICON, NPN	04713	SPS3414
Q1365	151-0190-00			TRANSISTOR: SILICON, NPN	07263	S032677
Q1370	151-0190-00			TRANSISTOR: SILICON, NPN	07263	S032677
Q1375	151-0188-00			TRANSISTOR: SILICON, PNP	04713	SPS6868K
Q1380	151-0190-00			TRANSISTOR: SILICON, NPN	07263	S032677
Q1385	151-0188-00			TRANSISTOR: SILICON, PNP	04713	SPS6868K
Q1420	151-0432-00			TRANSISTOR: SILICON, NPN	80009	151-0432-00
Q1425	151-0503-00			SCR: SILICON, TO-92	04713	SCR5138
Q1470	151-0432-00			TRANSISTOR: SILICON, NPN	80009	151-0432-00
Q1475	151-0432-00			TRANSISTOR: SILICON, NPN	80009	151-0432-00
Q1480	151-0432-00			TRANSISTOR: SILICON, NPN	80009	151-0432-00
Q1485	151-0432-00			TRANSISTOR: SILICON, NPN	80009	151-0432-00
Q1490	151-0188-00			TRANSISTOR: SILICON, PNP	04713	SPS6868K
Q1495	151-0432-00			TRANSISTOR: SILICON, NPN	80009	151-0432-00
Q1500	151-0188-00			TRANSISTOR: SILICON, PNP	04713	SPS6868K
Q1510	151-0190-00			TRANSISTOR: SILICON, NPN	07263	S032677
Q1525	151-0190-00			TRANSISTOR: SILICON, NPN	07263	S032677
Q1530	151-0432-00			TRANSISTOR: SILICON, NPN	80009	151-0432-00
Q1535	151-0190-00			TRANSISTOR: SILICON, NPN	07263	S032677
Q1536	151-0190-00			TRANSISTOR: SILICON, NPN	07263	S032677
Q1540	151-0190-00			TRANSISTOR: SILICON, NPN	07263	S032677
Q1545	151-0432-00			TRANSISTOR: SILICON, NPN	80009	151-0432-00
Q1570	151-0216-00			TRANSISTOR: SILICON, PNP	04713	SPS8803
Q1580	151-1078-00			TRANSISTOR: SILICON, JFE, N-CHANNEL	17856	J2133
Q1585	151-0188-00			TRANSISTOR: SILICON, PNP	04713	SPS6868K
Q1595	151-1066-00			TRANSISTOR: SILICON, FE, P-CHANNEL	80009	151-1066-00
Q1610	151-1022-00			TRANSISTOR: FET, N-CHAN, SI, F1782, TO-18	80009	151-1022-00
Q1630	151-0432-00			TRANSISTOR: SILICON, NPN	80009	151-0432-00
Q1665	151-0188-00			TRANSISTOR: SILICON, PNP	04713	SPS6868K
Q1670	151-0188-00			TRANSISTOR: SILICON, PNP	04713	SPS6868K
Q1675	151-0188-00			TRANSISTOR: SILICON, PNP	04713	SPS6868K
Q1680	151-0188-00			TRANSISTOR: SILICON, PNP	04713	SPS6868K
Q1685	151-0188-00			TRANSISTOR: SILICON, PNP	04713	SPS6868K
Q1690	151-0188-00			TRANSISTOR: SILICON, PNP	04713	SPS6868K
Q1705	151-0190-00			TRANSISTOR: SILICON, NPN	07263	S032677
Q1710	151-0190-00			TRANSISTOR: SILICON, NPN	07263	S032677
Q1715	151-0190-00			TRANSISTOR: SILICON, NPN	07263	S032677
Q1720	151-0190-00			TRANSISTOR: SILICON, NPN	07263	S032677
Q1725	151-0190-00			TRANSISTOR: SILICON, NPN	07263	S032677
Q1730	151-0190-00			TRANSISTOR: SILICON, NPN	07263	S032677
Q1749	151-0190-00			TRANSISTOR: SILICON, NPN	07263	S032677
Q1750	151-0190-00			TRANSISTOR: SILICON, NPN	07263	S032677
Q1760	151-0221-00			TRANSISTOR: SILICON, PNP	04713	SPS246
Q1764	151-0221-00			TRANSISTOR: SILICON, PNP	04713	SPS246
Q1768	151-0221-00			TRANSISTOR: SILICON, PNP	04713	SPS246
Q1772	151-0221-00			TRANSISTOR: SILICON, PNP	04713	SPS246
Q1776	151-0221-00			TRANSISTOR: SILICON, PNP	04713	SPS246
Q1786	151-0188-00			TRANSISTOR: SILICON, PNP	04713	SPS6868K
Q1790	151-0188-00			TRANSISTOR: SILICON, PNP	04713	SPS6868K
Q1794	151-0188-00			TRANSISTOR: SILICON, PNP	04713	SPS6868K

Ckt No.	Tektronix Part No.	Serial/Model No. Eff	Discont	Name & Description	Mfr Code	Mfr Part Number
Q1798	151-0188-00			TRANSISTOR:SILICON,PNP	04713	SPS6868K
Q1802	151-0188-00			TRANSISTOR:SILICON,PNP	04713	SPS6868K
Q1806	151-0188-00			TRANSISTOR:SILICON,PNP	04713	SPS6868K
Q1810	151-0188-00			TRANSISTOR:SILICON,PNP	04713	SPS6868K
Q1994	151-0188-00			TRANSISTOR:SILICON,PNP	04713	SPS6868K
Q2070	151-1045-00			TRANSISTOR:SILICON,JFE,P-CHANNEL	04713	SPS628
Q2075	151-0406-00			TRANSISTOR:SILICON,PNP	04713	OBD
Q2080	151-0426-00			TRANSISTOR:SILICON,NPN	03508	X44H242
Q2100	151-1066-00			TRANSISTOR:SILICON,FE,P-CHANNEL	80009	151-1066-00
Q2130	151-1066-00			TRANSISTOR:SILICON,FE,P-CHANNEL	80009	151-1066-00
Q2135	151-0432-00			TRANSISTOR:SILICON,NPN	80009	151-0432-00
Q2136	151-0432-00			TRANSISTOR:SILICON,NPN	80009	151-0432-00
Q2140	151-0190-00			TRANSISTOR:SILICON,NPN	07263	S032677
Q2150	151-1066-00			TRANSISTOR:SILICON,FE,P-CHANNEL	80009	151-1066-00
Q2195	151-1022-00			TRANSISTOR:FET,N-CHAN,SI,F1782,T0-18	80009	151-1022-00
Q2200	151-0415-00			TRANSISTOR:SILICON,NPN	04713	SJE419
Q2205	151-0188-00			TRANSISTOR:SILICON,PNP	04713	SPS6868K
Q2210	151-0432-00			TRANSISTOR:SILICON,NPN	80009	151-0432-00
Q2225	151-0432-00			TRANSISTOR:SILICON,NPN	80009	151-0432-00
Q2230	151-0432-00			TRANSISTOR:SILICON,NPN	80009	151-0432-00
Q2235	151-1066-00			TRANSISTOR:SILICON,FE,P-CHANNEL	80009	151-1066-00
Q2240	151-1066-00			TRANSISTOR:SILICON,FE,P-CHANNEL	80009	151-1066-00
Q2245	151-0190-00			TRANSISTOR:SILICON,NPN	07263	S032677
Q2250	151-0188-00			TRANSISTOR:SILICON,PNP	04713	SPS6868K
Q2275	151-0188-00			TRANSISTOR:SILICON,PNP	04713	SPS6868K
Q2280	151-0190-00			TRANSISTOR:SILICON,NPN	07263	S032677
Q2285	151-0188-00			TRANSISTOR:SILICON,PNP	04713	SPS6868K
Q2290	151-1045-00			TRANSISTOR:SILICON,JFE,P-CHANNEL	04713	SPS628
Q2330	151-0302-00			TRANSISTOR:SILICON,NPN	07263	S038487
Q2350	151-0301-00			TRANSISTOR:SILICON,PNP	27014	2N2907A
Q2370	151-0441-00			TRANSISTOR:SILICON,NPN	04713	SRF501
Q2380	151-0282-00			TRANSISTOR:SILICON,NPN	80009	151-0282-00
Q2385	151-0282-00			TRANSISTOR:SILICON,NPN	80009	151-0282-00
Q2390	151-0282-00			TRANSISTOR:SILICON,NPN	80009	151-0282-00
Q2395	151-0282-00			TRANSISTOR:SILICON,NPN	80009	151-0282-00
Q2410	151-0446-00			TRANSISTOR:SILICON,NPN	80009	151-0446-00
Q2420	151-0410-00			TRANSISTOR:SILICON,PNP	80009	151-0410-00
Q2430	151-0617-00			TRANSISTOR:SILICON,NPN	80009	151-0617-00
Q2440	151-0410-00			TRANSISTOR:SILICON,PNP	80009	151-0410-00
Q2570	151-0188-00			TRANSISTOR:SILICON,PNP	04713	SPS6868K
Q2580	151-0432-00			TRANSISTOR:SILICON,NPN	80009	151-0432-00
Q2585	151-1066-00			TRANSISTOR:SILICON,FE,P-CHANNEL	80009	151-1066-00
Q2590	151-0432-00			TRANSISTOR:SILICON,NPN	80009	151-0432-00
Q2620	151-0223-00			TRANSISTOR:SILICON,NPN	04713	SPS8026
Q2650	151-0188-00			TRANSISTOR:SILICON,PNP	04713	SPS6868K
Q2655	151-0190-00			TRANSISTOR:SILICON,NPN	07263	S032677
Q2660	151-0190-00			TRANSISTOR:SILICON,NPN	07263	S032677
Q2665	151-0190-00			TRANSISTOR:SILICON,NPN	07263	S032677
Q2670	151-0190-00			TRANSISTOR:SILICON,NPN	07263	S032677
Q2675	151-0190-00			TRANSISTOR:SILICON,NPN	07263	S032677
Q2680	151-0190-00			TRANSISTOR:SILICON,NPN	07263	S032677
Q2690	151-0658-00			TRANSISTOR:SILICON,NPN	80009	151-0658-00
Q2700	151-0410-00			TRANSISTOR:SILICON,PNP	80009	151-0410-00
Q2710	151-0341-00			TRANSISTOR:SILICON,NPN	07263	S040065
Q2715	151-0410-00			TRANSISTOR:SILICON,PNP	80009	151-0410-00
Q2720	151-0658-00			TRANSISTOR:SILICON,NPN	80009	151-0658-00
Q2730	151-0410-00			TRANSISTOR:SILICON,PNP	80009	151-0410-00

Replaceable Electrical Parts—7L18 Service

Ckt No.	Tektronix Part No.	Serial/Model No. Eff	Dscont	Name & Description	Mfr Code	Mfr Part Number
Q2735	151-0658-00			TRANSISTOR: SILICON, NPN	80009	151-0658-00
Q2740	151-0341-00			TRANSISTOR: SILICON, NPN	07263	S040065
Q2760	151-0658-00			TRANSISTOR: SILICON, NPN	80009	151-0658-00
Q2770	151-0410-00			TRANSISTOR: SILICON, PNP	80009	151-0410-00
Q2790	151-0410-00			TRANSISTOR: SILICON, PNP	80009	151-0410-00
Q2800	151-0658-00			TRANSISTOR: SILICON, NPN	80009	151-0658-00
Q2830	151-0302-00			TRANSISTOR: SILICON, NPN	07263	S038487
Q3010	151-0442-00			TRANSISTOR: SILICON, NPN	80009	151-0442-00
Q3015	151-0442-00			TRANSISTOR: SILICON, NPN	80009	151-0442-00
Q3040	151-0442-00			TRANSISTOR: SILICON, NPN	80009	151-0442-00
Q3050	151-0442-00			TRANSISTOR: SILICON, NPN	80009	151-0442-00
Q3060	151-0220-00			TRANSISTOR: SILICON, PNP	07263	S036228
Q3070	151-0341-00			TRANSISTOR: SILICON, NPN	07263	S040065
Q3075	151-0188-00			TRANSISTOR: SILICON, PNP	04713	SPS6868K
Q3090	151-0442-00			TRANSISTOR: SILICON, NPN	80009	151-0442-00
Q3100	151-0442-00			TRANSISTOR: SILICON, NPN	80009	151-0442-00
Q3130	151-0288-00			TRANSISTOR: SILICON, NPN	80009	151-0288-00
Q3135	151-0288-00			TRANSISTOR: SILICON, NPN	80009	151-0288-00
Q3165	151-0190-00			TRANSISTOR: SILICON, NPN	07263	S032677
Q3265	151-0220-00			TRANSISTOR: SILICON, PNP	07263	S036228
Q3270	151-0220-00			TRANSISTOR: SILICON, PNP	07263	S036228
Q3350	151-0341-00			TRANSISTOR: SILICON, NPN	07263	S040065
Q3355	151-0341-00			TRANSISTOR: SILICON, NPN	07263	S040065
Q3360	151-0341-00			TRANSISTOR: SILICON, NPN	07263	S040065
Q3430	151-0190-00			TRANSISTOR: SILICON, NPN	07263	S032677
Q3435	151-0190-00			TRANSISTOR: SILICON, NPN	07263	S032677
Q3440	151-0188-00			TRANSISTOR: SILICON, PNP	04713	SPS6868K
Q3450	151-0446-00			TRANSISTOR: SILICON, NPN	80009	151-0446-00
Q3490	151-0192-00			TRANSISTOR: SILICON, NPN, SEL FROM MPS6521	04713	SPS8801
Q3495	151-0405-00			TRANSISTOR: SILICON, NPN, SEL FROM MJE800	04713	SJE943
Q3550	151-0190-00			TRANSISTOR: SILICON, NPN	07263	S032677
Q3555	151-0190-00			TRANSISTOR: SILICON, NPN	07263	S032677
Q3610	151-0190-00			TRANSISTOR: SILICON, NPN	07263	S032677
Q3655	151-0188-00			TRANSISTOR: SILICON, PNP	04713	SPS6868K
R5A, B	311-1878-00			RES., VAR, WW: PNL, 2 X 2K OHM, 1W	32997	3541S-410-202/202
R50	315-0470-00			RES., FXD, CMPSN: 47 OHM, 5%, 0.25W	01121	CB4705
R52	315-0470-00			RES., FXD, CMPSN: 47 OHM, 5%, 0.25W	01121	CB4705
R92	303-0150-00			RES., FXD, CMPSN: 15 OHM, 5%, 1W	01121	GB1505
R100	315-0300-00	B010100	B020272	RES., FXD, CMPSN: 30 OHM, 5%, 0.25W	01121	CB3005
R100	315-0201-00	B020273	B020350	RES., FXD, CMPSN: 200 OHM, 5%, 0.25W	01121	CB2015
R100	315-0300-00	B020351		RES., FXD, CMPSN: 30 OHM, 5%, 0.25W	01121	CB3005
R101	307-0103-00	XB010150		RES., FXD, CMPSN: 2.7 OHM, 5%, 0.25W	01121	CB27G5
R102	315-0300-00	B010100	B020272	RES., FXD, CMPSN: 30 OHM, 5%, 0.25W	01121	CB3005
R102	315-0201-00	B020273	B020350	RES., FXD, CMPSN: 200 OHM, 5%, 0.25W	01121	CB2015
R102	315-0300-00	B020351		RES., FXD, CMPSN: 30 OHM, 5%, 0.25W	01121	CB3005
R103	307-0103-00	XB010150		RES., FXD, CMPSN: 2.7 OHM, 5%, 0.25W	01121	CB27G5
R104	315-0300-00	B010100	B020272	RES., FXD, CMPSN: 30 OHM, 5%, 0.25W	01121	CB3005
R104	315-0201-00	B020273	B020350	RES., FXD, CMPSN: 200 OHM, 5%, 0.25W	01121	CB2015
R104	315-0300-00	B020351		RES., FXD, CMPSN: 30 OHM, 5%, 0.25W	01121	CB3005
R106	315-0300-00	B010100	B020272	RES., FXD, CMPSN: 30 OHM, 5%, 0.25W	01121	CB3005
R106	315-0201-00	B020273	B020350	RES., FXD, CMPSN: 200 OHM, 5%, 0.25W	01121	CB2015
R106	315-0300-00	B020351		RES., FXD, CMPSN: 30 OHM, 5%, 0.25W	01121	CB3005
R108	315-0300-00	B010100	B020272	RES., FXD, CMPSN: 30 OHM, 5%, 0.25W	01121	CB3005
R108	315-0201-00	B020273	B020350	RES., FXD, CMPSN: 200 OHM, 5%, 0.25W	01121	CB2015
R108	315-0300-00	B020351		RES., FXD, CMPSN: 30 OHM, 5%, 0.25W	01121	CB3005
R110	315-0300-00	B010100	B020272	RES., FXD, CMPSN: 30 OHM, 5%, 0.25W	01121	CB3005
R110	315-0201-00	B020273	B020350	RES., FXD, CMPSN: 200 OHM, 5%, 0.25W	01121	CB2015

Ckt No.	Tektronix Part No.	Serial/Model No. Eff	Dscont	Name & Description	Mfr Code	Mfr Part Number
R110	315-0300-00	B020351		RES., FXD, CMPSN: 30 OHM, 5%, 0.25W	01121	CB3005
R112	315-0300-00	B010100	B020272	RES., FXD, CMPSN: 30 OHM, 5%, 0.25W	01121	CB3005
R112	315-0201-00	B020273	B020350	RES., FXD, CMPSN: 200 OHM, 5%, 0.25W	01121	CB2015
R112	315-0300-00	B020351		RES., FXD, CMPSN: 30 OHM, 5%, 0.25W	01121	CB3005
R114	315-0510-00			RES., FXD, CMPSN: 51 OHM, 5%, 0.25W	01121	CB5105
R116	315-0303-00			RES., FXD, CMPSN: 30K OHM, 5%, 0.25W	01121	CB3035
R118	315-0303-00			RES., FXD, CMPSN: 30K OHM, 5%, 0.25W	01121	CB3035
R120	315-0303-00			RES., FXD, CMPSN: 30K OHM, 5%, 0.25W	01121	CB3035
R122	315-0303-00			RES., FXD, CMPSN: 30K OHM, 5%, 0.25W	01121	CB3035
R124	315-0303-00			RES., FXD, CMPSN: 30K OHM, 5%, 0.25W	01121	CB3035
R126	315-0103-00			RES., FXD, CMPSN: 10K OHM, 5%, 0.25W	01121	CB1035
R128	315-0103-00			RES., FXD, CMPSN: 10K OHM, 5%, 0.25W	01121	CB1035
R129	315-0432-00			RES., FXD, CMPSN: 4.3K OHM, 5%, 0.25W	01121	CB4325
R130	315-0271-00			RES., FXD, CMPSN: 270 OHM, 5%, 0.25W	01121	CB2715
R132	315-0271-00			RES., FXD, CMPSN: 270 OHM, 5%, 0.25W	01121	CB2715
R134	315-0107-00			RES., FXD, CMPSN: 100M OHM, 5%, 0.25W	01121	CB1075
R136	315-0271-00			RES., FXD, CMPSN: 270 OHM, 5%, 0.25W	01121	CB2715
R138	315-0511-00			RES., FXD, CMPSN: 510 OHM, 5%, 0.25W	01121	CB5115
R140	315-0271-00			RES., FXD, CMPSN: 270 OHM, 5%, 0.25W	01121	CB2715
R142	315-0511-00			RES., FXD, CMPSN: 510 OHM, 5%, 0.25W	01121	CB5115
R144	315-0271-00			RES., FXD, CMPSN: 270 OHM, 5%, 0.25W	01121	CB2715
R145	315-0511-00			RES., FXD, CMPSN: 510 OHM, 5%, 0.25W	01121	CB5115
R146	315-0271-00			RES., FXD, CMPSN: 270 OHM, 5%, 0.25W	01121	CB2715
R148	315-0511-00			RES., FXD, CMPSN: 510 OHM, 5%, 0.25W	01121	CB5115
R150	315-0271-00			RES., FXD, CMPSN: 270 OHM, 5%, 0.25W	01121	CB2715
R152	315-0511-00			RES., FXD, CMPSN: 510 OHM, 5%, 0.25W	01121	CB5115
R154	315-0271-00			RES., FXD, CMPSN: 270 OHM, 5%, 0.25W	01121	CB2715
R156	315-0511-00			RES., FXD, CMPSN: 510 OHM, 5%, 0.25W	01121	CB5115
R158	315-0107-00			RES., FXD, CMPSN: 100M OHM, 5%, 0.25W	01121	CB1075
R160	315-0164-00			RES., FXD, CMPSN: 160K OHM, 5%, 0.25W	01121	CB1645
R162	315-0431-00			RES., FXD, CMPSN: 430 OHM, 5%, 0.25W	01121	CB4315
R164	315-0431-00			RES., FXD, CMPSN: 430 OHM, 5%, 0.25W	01121	CB4315
R166	315-0431-00			RES., FXD, CMPSN: 430 OHM, 5%, 0.25W	01121	CB4315
R168	315-0431-00			RES., FXD, CMPSN: 430 OHM, 5%, 0.25W	01121	CB4315
R170	315-0271-00			RES., FXD, CMPSN: 270 OHM, 5%, 0.25W	01121	CB2715
R172	315-0102-00			RES., FXD, CMPSN: 1K OHM, 5%, 0.25W	01121	CB1025
R174	315-0102-00			RES., FXD, CMPSN: 1K OHM, 5%, 0.25W	01121	CB1025
R176	315-0511-00			RES., FXD, CMPSN: 510 OHM, 5%, 0.25W	01121	CB5115
R178	315-0511-00			RES., FXD, CMPSN: 510 OHM, 5%, 0.25W	01121	CB5115
R180	315-0511-00			RES., FXD, CMPSN: 510 OHM, 5%, 0.25W	01121	CB5115
R182	315-0164-00			RES., FXD, CMPSN: 160K OHM, 5%, 0.25W	01121	CB1645
R184	315-0511-00			RES., FXD, CMPSN: 510 OHM, 5%, 0.25W	01121	CB5115
R185	315-0510-00			RES., FXD, CMPSN: 51 OHM, 5%, 0.25W	01121	CB5105
R186	315-0511-00			RES., FXD, CMPSN: 510 OHM, 5%, 0.25W	01121	CB5115
R188	315-0271-00			RES., FXD, CMPSN: 270 OHM, 5%, 0.25W	01121	CB2715
R190	315-0271-00			RES., FXD, CMPSN: 270 OHM, 5%, 0.25W	01121	CB2715
R192	315-0271-00			RES., FXD, CMPSN: 270 OHM, 5%, 0.25W	01121	CB2715
R194	315-0271-00			RES., FXD, CMPSN: 270 OHM, 5%, 0.25W	01121	CB2715
R196	315-0271-00			RES., FXD, CMPSN: 270 OHM, 5%, 0.25W	01121	CB2715
R197	315-0271-00			RES., FXD, CMPSN: 270 OHM, 5%, 0.25W	01121	CB2715
R198	315-0271-00			RES., FXD, CMPSN: 270 OHM, 5%, 0.25W	01121	CB2715
R200	311-1884-00			RES., VAR, NONWIR: CKT BD, 10K OHM, 0.5W	12697	CM40978
R201	315-0102-00			RES., FXD, CMPSN: 1K OHM, 5%, 0.25W	01121	CB1025
R203	321-0187-00			RES., FXD, FILM: 866 OHM, 1%, 0.125W	91637	MFF1816G866R0F
R204	315-0512-00			RES., FXD, CMPSN: 5.1K OHM, 5%, 0.25W	01121	CB5125
R205	311-1886-00			RES., VAR, NONWIR: CKT BD, 10K OHM, 0.5W	12697	CM40980
R208	315-0513-00			RES., FXD, CMPSN: 51K OHM, 5%, 0.25W	01121	CB5135

Replaceable Electrical Parts—7L18 Service

Ckt No.	Tektronix Part No.	Serial/Model No. Eff	Dscont	Name & Description	Mfr Code	Mfr Part Number
R210	311-1885-00			RES.,VAR, NONWIR:CKT BD,10K OHM,0.5W	12697	CM40979
R212	315-0512-00			RES.,FXD,CMPSN:5.1K OHM,5%,0.25W	01121	CB5125
R215	311-1886-00			RES.,VAR, NONWIR:CKT BD,10K OHM,0.5W	12697	CM40980
R217	315-0102-00			RES.,FXD,CMPSN:1K OHM,5%,0.25W	01121	CB1025
R220	311-1887-00			RES.,VAR, NONWIR:CKT BD,1K OHM,0.5W	12697	CM40981
R222	321-0295-00			RES.,FXD,FILM:11.5K OHM,1%,0.125W	91637	MFF1816G11501F
R223	315-0201-00			RES.,FXD,CMPSN:200 OHM,5%,0.25W	01121	CB2015
R224	315-0201-00			RES.,FXD,CMPSN:200 OHM,5%,0.25W	01121	CB2015
R225	311-1887-00			RES.,VAR, NONWIR:CKT BD,1K OHM,0.5W	12697	CM40981
R230	311-1887-00			RES.,VAR, NONWIR:CKT BD,1K OHM,0.5W	12697	CM40981
R231	315-0510-00			RES.,FXD,CMPSN:51 OHM,5%,0.25W	01121	CB5105
R232	315-0511-00			RES.,FXD,CMPSN:510 OHM,5%,0.25W	01121	CB5115
R234	315-0511-00			RES.,FXD,CMPSN:510 OHM,5%,0.25W	01121	CB5115
R235	311-1886-00			RES.,VAR, NONWIR:CKT BD,10K OHM,0.5W	12697	CM40980
R236	315-0102-00			RES.,FXD,CMPSN:1K OHM,5%,0.25W	01121	CB1025
R238	315-0511-00			RES.,FXD,CMPSN:510 OHM,5%,0.25W	01121	CB5115
R240	311-1884-00			RES.,VAR, NONWIR:CKT BD,10K OHM,0.5W	12697	CM40978
R243	315-0201-00			RES.,FXD,CMPSN:200 OHM,5%,0.25W	01121	CB2015
R244	315-0821-00			RES.,FXD,CMPSN:820 OHM,5%,0.25W	01121	CB8215
R246	315-0102-00			RES.,FXD,CMPSN:1K OHM,5%,0.25W	01121	CB1025
R248	315-0102-00			RES.,FXD,CMPSN:1K OHM,5%,0.25W	01121	CB1025
R250	315-0102-00			RES.,FXD,CMPSN:1K OHM,5%,0.25W	01121	CB1025
R252	315-0102-00			RES.,FXD,CMPSN:1K OHM,5%,0.25W	01121	CB1025
R254	315-0103-00			RES.,FXD,CMPSN:10K OHM,5%,0.25W	01121	CB1035
R256	315-0103-00			RES.,FXD,CMPSN:10K OHM,5%,0.25W	01121	CB1035
R258	315-0103-00			RES.,FXD,CMPSN:10K OHM,5%,0.25W	01121	CB1035
R260	315-0103-00			RES.,FXD,CMPSN:10K OHM,5%,0.25W	01121	CB1035
R300	308-0102-00	B010100	B010131X	RES.,FXD,WW:1.25K OHM,5%,.25W	91637	HL25022612500J
R302	315-0102-00	B010100	B010131X	RES.,FXD,CMPSN:1K OHM,5%,0.25W	01121	CB1025
R304	315-0102-00	B010100	B010131X	RES.,FXD,CMPSN:1K OHM,5%,0.25W	01121	CB1025
R308	308-0141-00			RES.,FXD,WW:1 OHM,5%,0.5W	80009	308-0141-00
R310	315-0222-00			RES.,FXD,CMPSN:2.2K OHM,5%,0.25W	01121	CB2225
R312	315-0752-00			RES.,FXD,CMPSN:7.5K OHM,5%,0.25W	01121	CB7525
R313	315-0752-00			RES.,FXD,CMPSN:7.5K OHM,5%,0.25W	01121	CB7525
R314	308-0240-00			RES.,FXD,WW:2 OHM,5%,3W	91637	RS2B-D2R000J
R316	321-0126-00			RES.,FXD,FILM:200 OHM,1%,0.125W	91637	MFF1816G200R0F
R318	321-0205-00			RES.,FXD,FILM:1.33K OHM,1%,0.125W	91637	MFF1816G13300F
R320	321-0356-00	B010100	B010119	RES.,FXD,FILM:49.9K OHM,1%,0.125W	91637	MFF1816G49901F
R320	321-0260-00	B010120		RES.,FXD,FILM:4.99K OHM,1%,0.125W	91637	MFF1816G49900F
R322	315-0102-00	B010100	B010131X	RES.,FXD,CMPSN:1K OHM,5%,0.25W	01121	CB1025
R324	315-0102-00	B010100	B010131X	RES.,FXD,CMPSN:1K OHM,5%,0.25W	01121	CB1025
R326	321-0289-00			RES.,FXD,FILM:10K OHM,1%,0.125W	91637	MFF1816G10001F
R328	321-0260-00			RES.,FXD,FILM:4.99K OHM,1%,0.125W	91637	MFF1816G49900F
R330	315-0154-00			RES.,FXD,CMPSN:150K OHM,5%,0.25W	01121	CB1545
R342	315-0102-00	B010100	B010131X	RES.,FXD,CMPSN:1K OHM,5%,0.25W	01121	CB1025
R344	315-0102-00	B010100	B010131X	RES.,FXD,CMPSN:1K OHM,5%,0.25W	01121	CB1025
R345	315-0392-00			RES.,FXD,CMPSN:3.9K OHM,5%,0.25W	01121	CB3925
R346	315-0471-00			RES.,FXD,CMPSN:470 OHM,5%,0.25W	01121	CB4715
R348	315-0754-00			RES.,FXD,CMPSN:750K OHM,5%,0.25W	01121	CB7545
R350	315-0102-00	B010100	B010131X	RES.,FXD,CMPSN:1K OHM,5%,0.25W	01121	CB1025
R351	315-0103-00			RES.,FXD,CMPSN:10K OHM,5%,0.25W	01121	CB1035
R352	315-0512-00			RES.,FXD,CMPSN:5.1K OHM,5%,0.25W	01121	CB5125
R353	315-0393-00			RES.,FXD,CMPSN:39K OHM,5%,0.25W	01121	CB3935
R354	315-0512-00			RES.,FXD,CMPSN:5.1K OHM,5%,0.25W	01121	CB5125
R356	315-0103-00			RES.,FXD,CMPSN:10K OHM,5%,0.25W	01121	CB1035
R358	315-0103-00			RES.,FXD,CMPSN:10K OHM,5%,0.25W	01121	CB1035
R360	315-0103-00			RES.,FXD,CMPSN:10K OHM,5%,0.25W	01121	CB1035

Replaceable Electrical Parts—7L18 Service

Ckt No.	Tektronix Part No.	Serial/Model No. Eff	Dscont	Name & Description	Mfr Code	Mfr Part Number
R362	315-0103-00			RES., FXD, CMPSN:10K OHM, 5%, 0.25W	01121	CB1035
R364	315-0103-00	XB010131		RES., FXD, CMPSN:10K OHM, 5%, 0.25W	01121	CB1035
R366	315-0103-00	XB010131		RES., FXD, CMPSN:10K OHM, 5%, 0.25W	01121	CB1035
R368	315-0103-00	XB010131		RES., FXD, CMPSN:10K OHM, 5%, 0.25W	01121	CB1035
R370	315-0103-00	XB010131		RES., FXD, CMPSN:10K OHM, 5%, 0.25W	01121	CB1035
R372	315-0103-00			RES., FXD, CMPSN:10K OHM, 5%, 0.25W	01121	CB1035
R373	315-0103-00	XB010131		RES., FXD, CMPSN:10K OHM, 5%, 0.25W	01121	CB1035
R374	315-0103-00	XB010131		RES., FXD, CMPSN:10K OHM, 5%, 0.25W	01121	CB1035
R375	301-0150-00			RES., FXD, CMPSN:15 OHM, 5%, 0.50W	01121	EB1505
R376	315-0103-00	XB010131		RES., FXD, CMPSN:10K OHM, 5%, 0.25W	01121	CB1035
R380	315-0103-00	XB010131		RES., FXD, CMPSN:10K OHM, 5%, 0.25W	01121	CB1035
R382	315-0103-00	XB010131		RES., FXD, CMPSN:10K OHM, 5%, 0.25W	01121	CB1035
R384	315-0103-00	XB010131		RES., FXD, CMPSN:10K OHM, 5%, 0.25W	01121	CB1035
R386	315-0103-00	XB010131		RES., FXD, CMPSN:10K OHM, 5%, 0.25W	01121	CB1035
R388	315-0103-00	XB010131		RES., FXD, CMPSN:10K OHM, 5%, 0.25W	01121	CB1035
R390	307-0475-00	XB010131		RES, NTWK, FXD, FI:10K OHM, (15)RES, DIP 16 LD	32997	4116R-002-103
R450	321-0753-06			RES., FXD, FILM:9K OHM, 0.25%, 0.125W	91637	MFF1816C90000C
R452	321-0753-06			RES., FXD, FILM:9K OHM, 0.25%, 0.125W	91637	MFF1816C90000C
R454	321-0289-06			RES., FXD, FILM:10K OHM, 0.25%, 0.125W	91637	MFF1816C10001C
R455	311-1337-00			RES., VAR, NONWIR:25K OHM, 10%, 0.50W	73138	89-129-1
R456	321-0289-06			RES., FXD, FILM:10K OHM, 0.25%, 0.125W	91637	MFF1816C10001C
R458	321-1358-07			RES., FXD, FILM:53K OHM, 0.1%, 0.125W	91637	MFF1816C53001B
R460	321-0644-00			RES., FXD, FILM:100K OHM, 0.25%, 0.125W	91637	MFF1816C10002C
R462	321-1644-00			RES., FXD, FILM:2.22M OHM, 1%, 0.125W	91637	HFF188G22203F
R464	321-0230-00			RES., FXD, FILM:2.43K OHM, 1%, 0.125W	91637	MFF1816G24300F
R466	321-0264-00			RES., FXD, FILM:5.49K OHM, 1%, 0.125W	91637	MFF1816G54900F
R468	308-0439-00			RES., FXD, WW:5.83K OHM, 0.5%, 3W	91637	RS2B-110-58300D
R470	321-0193-00			RES., FXD, FILM:1K OHM, 1%, 0.125W	91637	MFF1816G10000F
R472	321-0728-06			RES., FXD, FILM:136K OHM, 0.25%, 0.125W	91637	MFF1816C13602C
R474	321-1330-07			RES., FXD, FILM:27.1K OHM, 0.1%, 0.125W	91637	MFF1816C27101B
R475	311-1337-00			RES., VAR, NONWIR:25K OHM, 10%, 0.50W	73138	89-129-1
R476	321-0423-09			RES., FXD, FILM:249K OHM, 1%, 0.125W	24546	NE55E2493F
R478	321-0332-07			RES., FXD, FILM:28K OHM, 0.1%, 0.125W	91637	MFF1816C28001B
R479	315-0103-00			RES., FXD, CMPSN:10K OHM, 5%, 0.25W	01121	CB1035
R480	321-0294-00			RES., FXD, FILM:11.3K OHM, 1%, 0.125W	91637	MFF1816G11301F
R482	315-0512-00			RES., FXD, CMPSN:5.1K OHM, 5%, 0.25W	01121	CB5125
R484	321-0385-00			RES., FXD, FILM:100K OHM, 1%, 0.125W	91637	MFF1816G10002F
R486	315-0105-00			RES., FXD, CMPSN:1M OHM, 5%, 0.25W	01121	CB1055
R488	315-0472-00			RES., FXD, CMPSN:4.7K OHM, 5%, 0.25W	01121	CB4725
R489	315-0473-00			RES., FXD, CMPSN:47K OHM, 5%, 0.25W	01121	CB4735
R490	315-0470-00			RES., FXD, CMPSN:47 OHM, 5%, 0.25W	01121	CB4705
R493	321-0306-00			RES., FXD, FILM:15K OHM, 1%, 0.125W	91637	MFF1816G15001F
R494	321-0197-00			RES., FXD, FILM:1.1K OHM, 1%, 0.125W	91637	MFF1816G11000F
R495	315-0470-00			RES., FXD, CMPSN:47 OHM, 5%, 0.25W	01121	CB4705
R496	315-0150-00			RES., FXD, CMPSN:15 OHM, 5%, 0.25W	01121	CB1505
R497	315-0470-00			RES., FXD, CMPSN:47 OHM, 5%, 0.25W	01121	CB4705
R498	321-0197-00			RES., FXD, FILM:1.1K OHM, 1%, 0.125W	91637	MFF1816G11000F
R499	321-0306-00			RES., FXD, FILM:15K OHM, 1%, 0.125W	91637	MFF1816G15001F
R500	321-0332-07			RES., FXD, FILM:28K OHM, 0.1%, 0.125W	91637	MFF1816C28001B
R511	315-0103-00			RES., FXD, CMPSN:10K OHM, 5%, 0.25W	01121	CB1035
R520	321-0332-07			RES., FXD, FILM:28K OHM, 0.1%, 0.125W	91637	MFF1816C28001B
R522	321-0332-07			RES., FXD, FILM:28K OHM, 0.1%, 0.125W	91637	MFF1816C28001B
R523	315-0103-00			RES., FXD, CMPSN:10K OHM, 5%, 0.25W	01121	CB1035
R524	321-0332-07			RES., FXD, FILM:28K OHM, 0.1%, 0.125W	91637	MFF1816C28001B
R526	315-0103-00			RES., FXD, CMPSN:10K OHM, 5%, 0.25W	01121	CB1035
R527	315-0472-00			RES., FXD, CMPSN:4.7K OHM, 5%, 0.25W	01121	CB4725
R528	315-0473-00			RES., FXD, CMPSN:47K OHM, 5%, 0.25W	01121	CB4735

Replaceable Electrical Parts—7L18 Service

Ckt No.	Tektronix Part No.	Serial/Model No. Eff	Dscont	Name & Description	Mfr Code	Mfr Part Number
R529	315-0472-00			RES.,FXD,CMPSN:4.7K OHM,5%,0.25W	01121	CB4725
R530	321-0289-00			RES.,FXD,FILM:10K OHM,1%,0.125W	91637	MFF1816G10001F
R532	321-0289-00			RES.,FXD,FILM:10K OHM,1%,0.125W	91637	MFF1816G10001F
R533	321-0289-00			RES.,FXD,FILM:10K OHM,1%,0.125W	91637	MFF1816G10001F
R534	321-0236-00			RES.,FXD,FILM:2.8K OHM,1%,0.125W	91637	MFF1816G28000F
R536	315-0182-00			RES.,FXD,CMPSN:1.8K OHM,5%,0.25W	01121	CB1825
R538	321-0271-00			RES.,FXD,FILM:6.49K OHM,1%,0.125W	91637	MFF1816G64900F
R539	321-0342-00			RES.,FXD,FILM:35.7K OHM,1%,0.125W	91637	MFF1816G35701F
R540	321-0271-00			RES.,FXD,FILM:6.49K OHM,1%,0.125W	91637	MFF1816G64900F
R542	315-0202-00			RES.,FXD,CMPSN:2K OHM,5%,0.25W	01121	CB2025
R550	315-0510-00			RES.,FXD,CMPSN:51 OHM,5%,0.25W	01121	CB5105
R551	315-0510-00	B010100	B010149	RES.,FXD,CMPSN:51 OHM,5%,0.25W	01121	CB5105
R551	321-0090-00	B010150		RES.,FXD,FILM:84.5 OHM,1%,0.125W	91637	MFF1816G84R50F
R552	315-0101-00	B010100	B010149	RES.,FXD,CMPSN:100 OHM,5%,0.25W	01121	CB1015
R552	321-0087-00	B010150		RES.,FXD,FILM:78.7 OHM,1%,0.125W	91637	MFF1816G78R70F
R554	315-0122-00			RES.,FXD,CMPSN:1.2K OHM,5%,0.25W	01121	CB1225
R555	315-0432-00			RES.,FXD,CMPSN:4.3K OHM,5%,0.25W	01121	CB4325
R556	315-0681-00			RES.,FXD,CMPSN:680 OHM,5%,0.25W	01121	CB6815
R557	315-0680-00			RES.,FXD,CMPSN:68 OHM,5%,0.25W	01121	CB6805
R572	321-0305-00			RES.,FXD,FILM:14.7K OHM,1%,0.125W	91637	MFF1816G14701F
R576	321-0210-00			RES.,FXD,FILM:1.5K OHM,1%,0.125W	91637	MFF1816G15000F
R578	307-1079-00			PATT,RES,COND:LOG AMPLIFIER	80009	307-1079-00
R579	321-0234-00			RES.,FXD,FILM:2.67K OHM,1%,0.125W	91637	MFF1816G26700F
R580	321-0339-00			RES.,FXD,FILM:33.2K OHM,1%,0.125W	91637	MFF1816G33201F
R592	307-1079-00			PATT,RES,COND:LOG AMPLIFIER	80009	307-1079-00
R606	321-0296-00			RES.,FXD,FILM:11.8K OHM,1%,0.125W	91637	MFF1816G11801F
R608	315-0300-00			RES.,FXD,CMPSN:30 OHM,5%,0.25W	01121	CB3005
R612	321-0257-00			RES.,FXD,FILM:4.64K OHM,1%,0.125W	91637	MFF1816G46400F
R622	307-1079-00			PATT,RES,COND:LOG AMPLIFIER	80009	307-1079-00
R636	321-0276-00			RES.,FXD,FILM:7.32K OHM,1%,0.125W	91637	MFF1816G73200F
R638	315-0430-00			RES.,FXD,CMPSN:43 OHM,5%,0.25W	01121	CB4305
R642	321-0234-00			RES.,FXD,FILM:2.67K OHM,1%,0.125W	91637	MFF1816G26700F
R652	307-1079-00			PATT,RES,COND:LOG AMPLIFIER	80009	307-1079-00
R660	321-0111-00			RES.,FXD,FILM:140 OHM,1%,0.125W	91637	MFF1816G140R0F
R672	307-1079-00			PATT,RES,COND:LOG AMPLIFIER	80009	307-1079-00
R680	321-0111-00			RES.,FXD,FILM:140 OHM,1%,0.125W	91637	MFF1816G140R0F
R692	307-1079-00			PATT,RES,COND:LOG AMPLIFIER	80009	307-1079-00
R700	321-0111-00			RES.,FXD,FILM:140 OHM,1%,0.125W	91637	MFF1816G140R0F
R702	307-1079-00			PATT,RES,COND:LOG AMPLIFIER	80009	307-1079-00
R703	321-0389-00	B010100	B010149	RES.,FXD,FILM:110K OHM,1%,0.125W	91637	MFF1816G11002F
R703	321-0404-00	B010150		RES.,FXD,FILM:158K OHM,1%,0.125W	91637	MFF1816G15802F
R704	321-0423-00	B010100	B010149	RES.,FXD,FILM:249K OHM,1%,0.125W	91637	MFF1816G24902F
R704	321-0429-00	B010150		RES.,FXD,FILM:287K OHM,1%,0.125W	91637	MFF1816G28702F
R708	321-0111-00			RES.,FXD,FILM:140 OHM,1%,0.125W	91637	MFF1816G140R0F
R720	321-0181-00			RES.,FXD,FILM:750 OHM,1%,0.125W	91637	MFF1816G750R0F
R722	321-0389-00			RES.,FXD,FILM:110K OHM,1%,0.125W	91637	MFF1816G11002F
R724	315-0560-00			RES.,FXD,CMPSN:56 OHM,5%,0.25W	01121	CB5605
R725	311-1279-00			RES.,VAR,NONWIR:500 OHM,10%,0.50W	32997	3329W-L58-501
R726	315-0302-00			RES.,FXD,CMPSN:3K OHM,5%,0.25W	01121	CB3025
R727	321-0411-00	XB010150		RES.,FXD,FILM:187K OHM,1%,0.125W	91637	MFF1816G18702F
R728	321-0193-00			RES.,FXD,FILM:1K OHM,1%,0.125W	91637	MFF1816G10000F
R729	321-0436-00	XB010150		RES.,FXD,FILM:340K OHM,1%,0.125W	91637	MFF1816G34002F
R730	321-0268-00			RES.,FXD,FILM:6.04K OHM,1%,0.125W	91637	MFF1816G60400F
R731	321-0193-00			RES.,FXD,FILM:1K OHM,1%,0.125W	91637	MFF1816G10000F
R732	321-0289-00			RES.,FXD,FILM:10K OHM,1%,0.125W	91637	MFF1816G10001F
R733	315-0510-00			RES.,FXD,CMPSN:51 OHM,5%,0.25W	01121	CB5105
R734	321-0126-00			RES.,FXD,FILM:200 OHM,1%,0.125W	91637	MFF1816G200R0F

Replaceable Electrical Parts—7L18 Service

Ckt No.	Tektronix Part No.	Serial/Model No. Eff	Dscont	Name & Description	Mfr Code	Mfr Part Number
R736	321-0126-00			RES., FXD, FILM:200 OHM, 1%, 0.125W	91637	MFF1816G200ROF
R738	315-0751-00			RES., FXD, CMPSN:750 OHM, 5%, 0.25W	01121	CB7515
R740	315-0910-00			RES., FXD, CMPSN:91 OHM, 5%, 0.25W	01121	CB9105
R742	315-0181-00			RES., FXD, CMPSN:180 OHM, 5%, 0.25W	01121	CB1815
R744	315-0300-00			RES., FXD, CMPSN:30 OHM, 5%, 0.25W	01121	CB3005
R746	321-0041-00			RES., FXD, FILM:26.1 OHM, 1%, 0.125W	91637	MFF1816G26R10F
R747	323-0126-00			RES., FXD, FILM:200 OHM, 1%, 0.50W	75042	CECT0-2000F
R748	301-0102-00			RES., FXD, CMPSN:1K OHM, 5%, 0.50W	01121	EB1025
R750	315-0101-00			RES., FXD, CMPSN:100 OHM, 5%, 0.25W	01121	CB1015
R752	315-0300-00			RES., FXD, CMPSN:30 OHM, 5%, 0.25W	01121	CB3005
R754	321-0235-00			RES., FXD, FILM:2.74K OHM, 1%, 0.125W	91637	MFF1816G27400F
R756	321-0223-00			RES., FXD, FILM:2.05K OHM, 1%, 0.125W	91637	MFF1816G20500F
R758	321-0439-00			RES., FXD, FILM:365K OHM, 1%, 0.125W	91637	MFF1816G36502F
R759	321-0235-00			RES., FXD, FILM:2.74K OHM, 1%, 0.125W	91637	MFF1816G27400F
R760	321-0441-00			RES., FXD, FILM:383K OHM, 1%, 0.125W	91637	MFF1816G38302F
R762	321-0164-00			RES., FXD, FILM:499 OHM, 1%, 0.125W	91637	MFF1816G499ROF
R764	321-0440-00			RES., FXD, FILM:374K OHM, 1%, 0.125W	91637	MFF1816G37402F
R766	321-0411-00			RES., FXD, FILM:187K OHM, 1%, 0.125W	91637	MFF1816G18702F
R768	321-0164-00			RES., FXD, FILM:499 OHM, 1%, 0.125W	91637	MFF1816G499ROF
R774	321-0423-00			RES., FXD, FILM:249K OHM, 1%, 0.125W	91637	MFF1816G24902F
R775	311-1286-00			RES., VAR, NONWIR:50K OHM, 10%, 0.5W	32997	3329W-L58-503
R780	311-1286-00			RES., VAR, NONWIR:50K OHM, 10%, 0.5W	32997	3329W-L58-503
R782	321-0451-00			RES., FXD, FILM:487K OHM, 1%, 0.125W	91637	MFF1816G48702F
R784	321-0396-00			RES., FXD, FILM:130K OHM, 1%, 0.125W	91637	MFF1816G13002F
R786	315-0104-00			RES., FXD, CMPSN:100K OHM, 5%, 0.25W	01121	CB1045
R788	315-0104-00			RES., FXD, CMPSN:100K OHM, 5%, 0.25W	01121	CB1045
R790	321-0337-00			RES., FXD, FILM:31.6K OHM, 1%, 0.125W	91637	MFF1816G31601F
R792	321-0444-00			RES., FXD, FILM:412K OHM, 1%, 0.125W	91637	MFF1816G41202F
R793	315-0104-00			RES., FXD, CMPSN:100K OHM, 5%, 0.25W	01121	CB1045
R794	315-0105-00			RES., FXD, CMPSN:1M OHM, 5%, 0.25W	01121	CB1055
R798	315-0106-00			RES., FXD, CMPSN:10M OHM, 5%, 0.25W	01121	CB1065
R799	315-0104-00			RES., FXD, CMPSN:100K OHM, 5%, 0.25W	01121	CB1045
R800	311-1286-00			RES., VAR, NONWIR:50K OHM, 10%, 0.5W	32997	3329W-L58-503
R801	321-0430-00			RES., FXD, FILM:294K OHM, 1%, 0.125W	91637	MFF1816G29402F
R802	321-0438-00			RES., FXD, FILM:357K OHM, 1%, 0.125W	91637	MFF1816G35702F
R803	321-0289-00			RES., FXD, FILM:10K OHM, 1%, 0.125W	91637	MFF1816G10001F
R804	321-0451-00			RES., FXD, FILM:487K OHM, 1%, 0.125W	91637	MFF1816G48702F
R805	311-1277-00			RES., VAR, NONWIR:100 OHM, 10%, 0.5W	32997	3329W-L58-101
R806	321-0371-00			RES., FXD, FILM:71.5K OHM, 1%, 0.125W	91637	MFF1816G71501F
R807	321-0289-00			RES., FXD, FILM:10K OHM, 1%, 0.125W	91637	MFF1816G10001F
R808	321-0336-00			RES., FXD, FILM:30.9K OHM, 1%, 0.125W	91637	MFF1816G30901F
R809	315-0391-00	B010100	B010119	RES., FXD, CMPSN:390 OHM, 5%, 0.25W	01121	CB3915
R809	315-0301-00	B010120	B020299	RES., FXD, CMPSN:300 OHM, 5%, 0.25W	01121	CB3015
R809	315-0361-00	B020300		RES., FXD, CMPSN:360 OHM, 5%, 0.25W	01121	CB3615
R810	321-0298-00			RES., FXD, FILM:12.4K OHM, 1%, 0.125W	91637	MFF1816G12401F
R811	321-0336-00			RES., FXD, FILM:30.9K OHM, 1%, 0.125W	91637	MFF1816G30901F
R812	321-0250-00			RES., FXD, FILM:3.92K OHM, 1%, 0.125W	91637	MFF1816G39200F
R813	321-0276-00			RES., FXD, FILM:7.32K OHM, 1%, 0.125W	91637	MFF1816G73200F
R814	321-0336-00			RES., FXD, FILM:30.9K OHM, 1%, 0.125W	91637	MFF1816G30901F
R815	315-0104-00			RES., FXD, CMPSN:100K OHM, 5%, 0.25W	01121	CB1045
R816	321-0213-00			RES., FXD, FILM:1.62K OHM, 1%, 0.125W	91637	MFF1816G16200F
R817	315-0512-00			RES., FXD, CMPSN:5.1K OHM, 5%, 0.25W	01121	CB5125
R818	315-0122-00			RES., FXD, CMPSN:1.2K OHM, 5%, 0.25W	01121	CB1225
R819	315-0393-00			RES., FXD, CMPSN:39K OHM, 5%, 0.25W	01121	CB3935
R826	315-0470-00			RES., FXD, CMPSN:47 OHM, 5%, 0.25W	01121	CB4705
R827	321-0157-00			RES., FXD, FILM:422 OHM, 1%, 0.125W	91637	MFF1816G422ROF
R828	315-0303-00			RES., FXD, CMPSN:30K OHM, 5%, 0.25W	01121	CB3035

Replaceable Electrical Parts—7L18 Service

Ckt No.	Tektronix Part No.	Serial/Model No. Eff Dscont	Name & Description	Mfr Code	Mfr Part Number
R830	315-0303-00		RES., FXD, CMPSN: 30K OHM, 5%, 0.25W	01121	CB3035
R832	315-0470-00		RES., FXD, CMPSN: 47 OHM, 5%, 0.25W	01121	CB4705
R834	315-0202-00		RES., FXD, CMPSN: 2K OHM, 5%, 0.25W	01121	CB2025
R838	315-0332-00		RES., FXD, CMPSN: 3.3K OHM, 5%, 0.25W	01121	CB3325
R842	315-0152-00		RES., FXD, CMPSN: 1.5K OHM, 5%, 0.25W	01121	CB1525
R844	321-0238-00		RES., FXD, FILM: 2.94K OHM, 1%, 0.125W	91637	MFF1816G29400F
R846	315-0433-00		RES., FXD, CMPSN: 43K OHM, 5%, 0.25W	01121	CB4335
R848	315-0333-00		RES., FXD, CMPSN: 33K OHM, 5%, 0.25W	01121	CB3335
R850	315-0391-00		RES., FXD, CMPSN: 390 OHM, 5%, 0.25W	01121	CB3915
R852	315-0431-00		RES., FXD, CMPSN: 430 OHM, 5%, 0.25W	01121	CB4315
R854	321-0193-00		RES., FXD, FILM: 1K OHM, 1%, 0.125W	91637	MFF1816G10000F
R856	315-0302-00		RES., FXD, CMPSN: 3K OHM, 5%, 0.25W	01121	CB3025
R858	315-0511-00		RES., FXD, CMPSN: 510 OHM, 5%, 0.25W	01121	CB5115
R860	321-0195-00		RES., FXD, FILM: 1.05K OHM, 1%, 0.125W	91637	MFF1816G10500F
R862	315-0471-00		RES., FXD, CMPSN: 470 OHM, 5%, 0.25W	01121	CB4715
R864	315-0302-00		RES., FXD, CMPSN: 3K OHM, 5%, 0.25W	01121	CB3025
R866	321-0068-00		RES., FXD, FILM: 49.9 OHM, 1%, 0.125W	91637	MFF1816G49R90F
R868	321-0068-00		RES., FXD, FILM: 49.9 OHM, 1%, 0.125W	91637	MFF1816G49R90F
R870	321-0068-00		RES., FXD, FILM: 49.9 OHM, 1%, 0.125W	91637	MFF1816G49R90F
R872	321-0068-00		RES., FXD, FILM: 49.9 OHM, 1%, 0.125W	91637	MFF1816G49R90F
R876	321-0281-00		RES., FXD, FILM: 8.25K OHM, 1%, 0.125W	91637	MFF1816G82500F
R878	321-0224-00		RES., FXD, FILM: 2.1K OHM, 1%, 0.125W	91637	MFF1816G21000F
R880	315-0222-00		RES., FXD, CMPSN: 2.2K OHM, 5%, 0.25W	01121	CB2225
R882	315-0131-00		RES., FXD, CMPSN: 130 OHM, 5%, 0.25W	01121	CB1315
R883	315-0103-00		RES., FXD, CMPSN: 10K OHM, 5%, 0.25W	01121	CB1035
R884	315-0513-00		RES., FXD, CMPSN: 51K OHM, 5%, 0.25W	01121	CB5135
R890	315-0912-00		RES., FXD, CMPSN: 9.1K OHM, 5%, 0.25W	01121	CB9125
R892	315-0512-00		RES., FXD, CMPSN: 5.1K OHM, 5%, 0.25W	01121	CB5125
R894	315-0823-00		RES., FXD, CMPSN: 82K OHM, 5%, 0.25W	01121	CB8235
R896	315-0432-00		RES., FXD, CMPSN: 4.3K OHM, 5%, 0.25W	01121	CB4325
R897	315-0823-00		RES., FXD, CMPSN: 82K OHM, 5%, 0.25W	01121	CB8235
R898	315-0432-00		RES., FXD, CMPSN: 4.3K OHM, 5%, 0.25W	01121	CB4325
R899	315-0623-00		RES., FXD, CMPSN: 62K OHM, 5%, 0.25W	01121	CB6235
R940	315-0361-00		RES., FXD, CMPSN: 360 OHM, 5%, 0.25W	01121	CB3615
R942	315-0241-00		RES., FXD, CMPSN: 240 OHM, 5%, 0.25W	01121	CB2415
R944	315-0152-00		RES., FXD, CMPSN: 1.5K OHM, 5%, 0.25W	01121	CB1525
R946	315-0301-00		RES., FXD, CMPSN: 300 OHM, 5%, 0.25W	01121	CB3015
R947	315-0101-00		RES., FXD, CMPSN: 100 OHM, 5%, 0.25W	01121	CB1015
R952	315-0470-00		RES., FXD, CMPSN: 47 OHM, 5%, 0.25W	01121	CB4705
R954	315-0470-00		RES., FXD, CMPSN: 47 OHM, 5%, 0.25W	01121	CB4705
R956	315-0470-00		RES., FXD, CMPSN: 47 OHM, 5%, 0.25W	01121	CB4705
R960	315-0621-00		RES., FXD, CMPSN: 620 OHM, 5%, 0.25W	01121	CB6215
R961	315-0102-00		RES., FXD, CMPSN: 1K OHM, 5%, 0.25W	01121	CB1025
R962	315-0102-00		RES., FXD, CMPSN: 1K OHM, 5%, 0.25W	01121	CB1025
R964	315-0512-00		RES., FXD, CMPSN: 5.1K OHM, 5%, 0.25W	01121	CB5125
R966	315-0512-00		RES., FXD, CMPSN: 5.1K OHM, 5%, 0.25W	01121	CB5125
R968	315-0512-00		RES., FXD, CMPSN: 5.1K OHM, 5%, 0.25W	01121	CB5125
R970	315-0512-00		RES., FXD, CMPSN: 5.1K OHM, 5%, 0.25W	01121	CB5125
R972	315-0471-00		RES., FXD, CMPSN: 470 OHM, 5%, 0.25W	01121	CB4715
R974	315-0103-00		RES., FXD, CMPSN: 10K OHM, 5%, 0.25W	01121	CB1035
R976	315-0471-00		RES., FXD, CMPSN: 470 OHM, 5%, 0.25W	01121	CB4715
R978	315-0103-00		RES., FXD, CMPSN: 10K OHM, 5%, 0.25W	01121	CB1035
R980	315-0470-00		RES., FXD, CMPSN: 47 OHM, 5%, 0.25W	01121	CB4705
R982	315-0471-00		RES., FXD, CMPSN: 470 OHM, 5%, 0.25W	01121	CB4715
R984	315-0103-00		RES., FXD, CMPSN: 10K OHM, 5%, 0.25W	01121	CB1035
R986	315-0471-00		RES., FXD, CMPSN: 470 OHM, 5%, 0.25W	01121	CB4715
R988	315-0103-00		RES., FXD, CMPSN: 10K OHM, 5%, 0.25W	01121	CB1035

Ckt No.	Tektronix Part No.	Serial/Model No. Eff	Dscont	Name & Description	Mfr Code	Mfr Part Number
R992	321-0068-00			RES., FXD, FILM:49.9 OHM, 1%, 0.125W	91637	MFF1816G49R90F
R994	321-0068-00			RES., FXD, FILM:49.9 OHM, 1%, 0.125W	91637	MFF1816G49R90F
R996	321-0068-00			RES., FXD, FILM:49.9 OHM, 1%, 0.125W	91637	MFF1816G49R90F
R998	321-0068-00			RES., FXD, FILM:49.9 OHM, 1%, 0.125W	91637	MFF1816G49R90F
R1000	315-0510-00			RES., FXD, CMPSN:51 OHM, 5%, 0.25W	01121	CB5105
R1002	315-0101-00			RES., FXD, CMPSN:100 OHM, 5%, 0.25W	01121	CB1015
R1004	315-0302-00			RES., FXD, CMPSN:3K OHM, 5%, 0.25W	01121	CB3025
R1006	315-0152-00			RES., FXD, CMPSN:1.5K OHM, 5%, 0.25W	01121	CB1525
R1008	315-0101-00			RES., FXD, CMPSN:100 OHM, 5%, 0.25W	01121	CB1015
R1010	315-0151-00			RES., FXD, CMPSN:150 OHM, 5%, 0.25W	01121	CB1515
R1011	315-0102-00	XB010120		RES., FXD, CMPSN:1K OHM, 5%, 0.25W	01121	CB1025
R1012	315-0561-00			RES., FXD, CMPSN:560 OHM, 5%, 0.25W	01121	CB5615
R1014	315-0102-00			RES., FXD, CMPSN:1K OHM, 5%, 0.25W	01121	CB1025
R1016	315-0102-00			RES., FXD, CMPSN:1K OHM, 5%, 0.25W	01121	CB1025
R1018	315-0102-00			RES., FXD, CMPSN:1K OHM, 5%, 0.25W	01121	CB1025
R1020	315-0102-00			RES., FXD, CMPSN:18K OHM, 5%, 0.25W	01121	CB1025
R1022	321-0251-00			RES., FXD, FILM:4.02K OHM, 1%, 0.125W	91637	MFF1816G40200F
R1024	321-0251-00			RES., FXD, FILM:4.02K OHM, 1%, 0.125W	91637	MFF1816G40200F
R1030	315-0471-00			RES., FXD, CMPSN:470 OHM, 5%, 0.25W	01121	CB4715
R1032	315-0470-00			RES., FXD, CMPSN:47 OHM, 5%, 0.25W	01121	CB4705
R1034	315-0471-00			RES., FXD, CMPSN:470 OHM, 5%, 0.25W	01121	CB4715
R1040	315-0220-00			RES., FXD, CMPSN:22 OHM, 5%, 0.25W	01121	CB2205
R1042	315-0183-00			RES., FXD, CMPSN:18K OHM, 5%, 0.25W	01121	CB1835
R1045	315-0220-00			RES., FXD, CMPSN:22 OHM, 5%, 0.25W	01121	CB2205
R1046	315-0622-00			RES., FXD, CMPSN:6.2K OHM, 5%, 0.25W	01121	CB6225
R1047	315-0113-00			RES., FXD, CMPSN:11K OHM, 5%, 0.25W	01121	CB1135
R1048	315-0122-00			RES., FXD, CMPSN:1.2K OHM, 5%, 0.25W	01121	CB1225
R1049	315-0182-00			RES., FXD, CMPSN:1.8K OHM, 5%, 0.25W	01121	CB1825
R1050	315-0301-00			RES., FXD, CMPSN:300 OHM, 5%, 0.25W	01121	CB3015
R1051	315-0220-00			RES., FXD, CMPSN:22 OHM, 5%, 0.25W	01121	CB2205
R1052	315-0201-00			RES., FXD, CMPSN:200 OHM, 5%, 0.25W	01121	CB2015
R1053	315-0151-00			RES., FXD, CMPSN:150 OHM, 5%, 0.25W	01121	CB1515
R1054	315-0510-00			RES., FXD, CMPSN:51 OHM, 5%, 0.25W	01121	CB5105
R1055	315-0113-00			RES., FXD, CMPSN:11K OHM, 5%, 0.25W	01121	CB1135
R1056	315-0200-00			RES., FXD, CMPSN:20 OHM, 5%, 0.25W	01121	CB2005
R1057	315-0112-00			RES., FXD, CMPSN:1.1K OHM, 5%, 0.25W	01121	CB1125
R1058	315-0101-00			RES., FXD, CMPSN:100 OHM, 5%, 0.25W	01121	CB1015
R1060	315-0182-00			RES., FXD, CMPSN:1.8K OHM, 5%, 0.25W	01121	CB1825
R1062	315-0100-00			RES., FXD, CMPSN:10 OHM, 5%, 0.25W	01121	CB1005
R1064	315-0391-00			RES., FXD, CMPSN:390 OHM, 5%, 0.25W	01121	CB3915
R1070	321-0193-00			RES., FXD, FILM:1K OHM, 1%, 0.125W	91637	MFF1816G10000F
R1072	315-0512-00			RES., FXD, CMPSN:5.1K OHM, 5%, 0.25W	01121	CB5125
R1080	-----			(FURNISHED AS A UNIT WITH A940A5)		
R1082	-----			(FURNISHED AS A UNIT WITH A940A5)		
R1084	-----			(FURNISHED AS A UNIT WITH A940A5)		
R1090	315-0301-00			RES., FXD, CMPSN:300 OHM, 5%, 0.25W	01121	CB3015
R1091	315-0220-00			RES., FXD, CMPSN:22 OHM, 5%, 0.25W	01121	CB2205
R1092	315-0152-00			RES., FXD, CMPSN:1.5K OHM, 5%, 0.25W	01121	CB1525
R1093	315-0220-00			RES., FXD, CMPSN:22 OHM, 5%, 0.25W	01121	CB2205
R1094	315-0621-00			RES., FXD, CMPSN:620 OHM, 5%, 0.25W	01121	CB6215
R1095	315-0102-00			RES., FXD, CMPSN:1K OHM, 5%, 0.25W	01121	CB1025
R1096	315-0751-00			RES., FXD, CMPSN:750 OHM, 5%, 0.25W	01121	CB7515
R1098	315-0302-00			RES., FXD, CMPSN:3K OHM, 5%, 0.25W	01121	CB3025
R1100	315-0470-00			RES., FXD, CMPSN:47 OHM, 5%, 0.25W	01121	CB4705
R1102	321-0174-00			RES., FXD, FILM:634 OHM, 1%, 0.125W	91637	MFF1816G634R0F
R1103	315-0220-00			RES., FXD, CMPSN:22 OHM, 5%, 0.25W	01121	CB2205
R1104	315-0201-00			RES., FXD, CMPSN:200 OHM, 5%, 0.25W	01121	CB2015

Replaceable Electrical Parts—7L18 Service

Ckt No.	Tektronix Part No.	Serial/Model No. Eff	Dscont	Name & Description	Mfr Code	Mfr Part Number
R1112	321-0154-00			RES., FXD, FILM: 392 OHM, 1%, 0.125W	91637	MFF1816G392R0F
R1130	321-0891-00			RES., FXD, FILM: 800K OHM, 1%, 0.125W	91637	MFF1816G80002F
R1131	323-0289-00			RES., FXD, FILM: 10K OHM, 1%, 0.50W	75042	CECT0-1002F
R1132	321-0289-09			RES., FXD, FILM: 10K OHM, 1%, 0.125W	91637	MFF1816G10001F
R1133	323-0289-00			RES., FXD, FILM: 10K OHM, 1%, 0.50W	75042	CECT0-1002F
R1134	321-0424-00			RES., FXD, FILM: 255K OHM, 1%, 0.125W	91637	MFF1816G25502F
R1135	321-0276-00			RES., FXD, FILM: 7.32K OHM, 1%, 0.125W	91637	MFF1816G73200F
R1137	321-0311-00			RES., FXD, FILM: 16.9K OHM, 1%, 0.125W	91637	MFF1816G16901F
R1138	321-0313-09			RES., FXD, FILM: 17.8K OHM, 1%, 0.125W	24546	NE55E1782F
R1139	321-0298-09			RES., FXD, FILM: 12.4K OHM, 1%, 0.125W	24546	NE55E1242F
R1140	315-0101-00			RES., FXD, CMPSN: 100 OHM, 5%, 0.25W	01121	CB1015
R1141	321-0402-00			RES., FXD, FILM: 150K OHM, 1%, 0.125W	24546	NA55D1503F
R1142	315-0101-00			RES., FXD, CMPSN: 100 OHM, 5%, 0.25W	01121	CB1015
R1143	321-0289-09			RES., FXD, FILM: 10K OHM, 1%, 0.125W	91637	MFF1816G10001F
R1144	321-0241-00			RES., FXD, FILM: 3.16K OHM, 1%, 0.125W	91637	MFF1816G31600F
R1145	315-0470-00			RES., FXD, CMPSN: 47 OHM, 5%, 0.25W	01121	CB4705
R1146	321-0356-00			RES., FXD, FILM: 49.9K OHM, 1%, 0.125W	91637	MFF1816G49901F
R1147	321-0295-00			RES., FXD, FILM: 11.5K OHM, 1%, 0.125W	91637	MFF1816G11501F
R1150	315-0470-00	B010100	B010149	RES., FXD, CMPSN: 47 OHM, 5%, 0.25W	01121	CB4705
R1150	315-0201-00	B010150		RES., FXD, CMPSN: 200 OHM, 5%, 0.25W	01121	CB2015
R1152	321-0165-00			RES., FXD, FILM: 511 OHM, 1%, 0.125W	91637	MFF1816G511R0F
R1153	315-0105-00			RES., FXD, CMPSN: 1M OHM, 5%, 0.25W	01121	CB1055
R1154	321-0047-00			RES., FXD, FILM: 30.1 OHM, 1%, 0.125W	91637	MFF1816G30R10F
R1155	315-0102-00			RES., FXD, CMPSN: 1K OHM, 5%, 0.25W	01121	CB1025
R1156	321-0165-00	B010100	B010149X	RES., FXD, FILM: 511 OHM, 1%, 0.125W (SN B010150 & UP R1156 IS REPL W/A WIRE STRAP)	91637	MFF1816G511R0F
R1157	315-0513-00			RES., FXD, CMPSN: 51K OHM, 5%, 0.25W	01121	CB5135
R1158	315-0202-00			RES., FXD, CMPSN: 2K OHM, 5%, 0.25W	01121	CB2025
R1159	315-0821-00			RES., FXD, CMPSN: 820 OHM, 5%, 0.25W	01121	CB8215
R1160	321-0164-00			RES., FXD, FILM: 499 OHM, 1%, 0.125W	91637	MFF1816G499R0F
R1167	315-0561-00			RES., FXD, CMPSN: 560 OHM, 5%, 0.25W	01121	CB5615
R1168	315-0561-00			RES., FXD, CMPSN: 560 OHM, 5%, 0.25W	01121	CB5615
R1169	315-0100-00			RES., FXD, CMPSN: 10 OHM, 5%, 0.25W	01121	CB1005
R1170	315-0103-00			RES., FXD, CMPSN: 10K OHM, 5%, 0.25W	01121	CB1035
R1171	315-0103-00			RES., FXD, CMPSN: 10K OHM, 5%, 0.25W	01121	CB1035
R1172	315-0103-00			RES., FXD, CMPSN: 10K OHM, 5%, 0.25W	01121	CB1035
R1173	315-0100-00			RES., FXD, CMPSN: 10 OHM, 5%, 0.25W	01121	CB1005
R1174	315-0103-00			RES., FXD, CMPSN: 10K OHM, 5%, 0.25W	01121	CB1035
R1176	315-0472-00			RES., FXD, CMPSN: 4.7K OHM, 5%, 0.25W	01121	CB4725
R1177	315-0100-00			RES., FXD, CMPSN: 10 OHM, 5%, 0.25W	01121	CB1005
R1179	315-0100-00			RES., FXD, CMPSN: 10 OHM, 5%, 0.25W	01121	CB1005
R1180	315-0105-00	B010100	B010119	RES., FXD, CMPSN: 1M OHM, 5%, 0.25W	01121	CB1055
R1180	315-0103-00	B010120		RES., FXD, CMPSN: 10K OHM, 5%, 0.25W	01121	CB1035
R1182	321-0155-00			RES., FXD, FILM: 402 OHM, 1%, 0.125W	91637	MFF1816G402R0F
R1184	311-1281-00			RES., VAR, NONWIR: 2.5K OHM, 10%, 0.5W	32997	3329W-L58-252
R1186	321-0193-00			RES., FXD, FILM: 1K OHM, 1%, 0.125W	91637	MFF1816G10000F
R1188	315-0105-00			RES., FXD, CMPSN: 1M OHM, 5%, 0.25W	01121	CB1055
R1200	315-0102-00			RES., FXD, CMPSN: 1K OHM, 5%, 0.25W	01121	CB1025
R1204	321-0280-00			RES., FXD, FILM: 8.06K OHM, 1%, 0.125W	91637	MFF1816G80600F
R1206	321-0114-00			RES., FXD, FILM: 150 OHM, 1%, 0.125W	91637	MFF1816G150R0F
R1208	321-0385-00			RES., FXD, FILM: 100K OHM, 1%, 0.125W	91637	MFF1816G10002F
R1210	321-0360-00			RES., FXD, FILM: 54.9K OHM, 1%, 0.125W	91637	MFF1816G54901F
R1212	321-0406-00			RES., FXD, FILM: 165K OHM, 1%, 0.125W	91637	MFF1816G16502F
R1214	321-0443-00			RES., FXD, FILM: 402K OHM, 1%, 0.125W	91637	MFF1816G40202F
R1216	315-0104-00			RES., FXD, CMPSN: 100K OHM, 5%, 0.25W	01121	CB1045
R1218	321-0440-00			RES., FXD, FILM: 374K OHM, 1%, 0.125W	91637	MFF1816G37402F
R1219	321-0318-00			RES., FXD, FILM: 20K OHM, 1%, 0.125W	91637	MFF1816G20001F

Ckt No.	Tektronix Part No.	Serial/Model No. Eff	Dscont	Name & Description	Mfr Code	Mfr Part Number
R1220	321-0397-00			RES.,FXD,FILM:133K OHM,1%,0.125W	91637	MFF1816G13302F
R1221	315-0201-00			RES.,FXD,CMPSN:200 OHM,5%,0.25W	01121	CB2015
R1223	315-0105-00			RES.,FXD,CMPSN:1M OHM,5%,0.25W	01121	CB1055
R1224	321-0350-00			RES.,FXD,FILM:43.2K OHM,1%,0.125W	91637	MFF1816G43201F
R1225	321-0289-00			RES.,FXD,FILM:10K OHM,1%,0.125W	91637	MFF1816G10001F
R1226	321-0289-00			RES.,FXD,FILM:10K OHM,1%,0.125W	91637	MFF1816G10001F
R1227	321-0335-00			RES.,FXD,FILM:30.1K OHM,1%,0.125W	91637	MFF1816G30101F
R1228	315-0303-00			RES.,FXD,CMPSN:30K OHM,5%,0.25W	01121	CB3035
R1229	321-0335-00			RES.,FXD,FILM:30.1K OHM,1%,0.125W	91637	MFF1816G30101F
R1230	315-0103-00			RES.,FXD,CMPSN:10K OHM,5%,0.25W	01121	CB1035
R1232	323-0257-00			RES.,FXD,FILM:4.64K OHM,1%,0.50W	91637	MFF12226G46400F
R1233	321-0397-09			RES.,FXD,FILM:133K OHM,1%,0.125W	24546	NE55E1333F
R1234	315-0471-00			RES.,FXD,CMPSN:470 OHM,5%,0.25W	01121	CB4715
R1236	315-0471-00			RES.,FXD,CMPSN:470 OHM,5%,0.25W	01121	CB4715
R1238	315-0471-00			RES.,FXD,CMPSN:470 OHM,5%,0.25W	01121	CB4715
R1240	315-0154-00			RES.,FXD,CMPSN:15K OHM,5%,0.25W	01121	CB1545
R1241	321-0289-00			RES.,FXD,FILM:10K OHM,1%,0.125W	91637	MFF1816G10001F
R1242	321-0289-00			RES.,FXD,FILM:10K OHM,1%,0.125W	91637	MFF1816G10001F
R1243	315-0433-00			RES.,FXD,CMPSN:43K OHM,5%,0.25W	01121	CB4335
R1244	315-0103-00			RES.,FXD,CMPSN:10K OHM,5%,0.25W	01121	CB1035
R1246	315-0103-00			RES.,FXD,CMPSN:10K OHM,5%,0.25W	01121	CB1035
R1248	315-0334-00			RES.,FXD,CMPSN:330K OHM,5%,0.25W	01121	CB3345
R1252	315-0472-00			RES.,FXD,CMPSN:4.7K OHM,5%,0.25W	01121	CB4725
R1254	321-0222-00			RES.,FXD,FILM:2K OHM,1%,0.125W	91637	MFF1816G20000F
R1256	315-0103-00			RES.,FXD,CMPSN:10K OHM,5%,0.25W	01121	CB1035
R1260	311-1279-00			RES.,VAR,NONWIR:500 OHM,10%,0.50W	32997	3329W-L58-501
R1261	315-0105-00			RES.,FXD,CMPSN:1M OHM,5%,0.25W	01121	CB1055
R1262	315-0201-00			RES.,FXD,CMPSN:200 OHM,5%,0.25W	01121	CB2015
R1263	315-0102-00			RES.,FXD,CMPSN:1K OHM,5%,0.25W	01121	CB1025
R1265	315-0474-00			RES.,FXD,CMPSN:470K OHM,5%,0.25W	01121	CB4745
R1266	315-0102-00			RES.,FXD,CMPSN:1K OHM,5%,0.25W	01121	CB1025
R1267	315-0474-00			RES.,FXD,CMPSN:470K OHM,5%,0.25W	01121	CB4745
R1269	315-0474-00			RES.,FXD,CMPSN:470K OHM,5%,0.25W	01121	CB4745
R1270	315-0471-00			RES.,FXD,CMPSN:470 OHM,5%,0.25W	01121	CB4715
R1272	321-0673-07			RES.,FXD,FILM:17K OHM,0.1%,0.125W	91637	MFF1816C17001B
R1274	315-0163-00			RES.,FXD,CMPSN:16K OHM,5%,0.25W	01121	CB1635
R1275	321-0289-00			RES.,FXD,FILM:10K OHM,1%,0.125W	91637	MFF1816G10001F
R1276	315-0133-00			RES.,FXD,CMPSN:13K OHM,5%,0.25W	01121	CB1335
R1278	315-0163-00			RES.,FXD,CMPSN:16K OHM,5%,0.25W	01121	CB1635
R1279	315-0104-00			RES.,FXD,CMPSN:100K OHM,5%,0.25W	01121	CB1045
R1280	315-0133-00			RES.,FXD,CMPSN:13K OHM,5%,0.25W	01121	CB1335
R1281	315-0100-00			RES.,FXD,CMPSN:10 OHM,5%,0.25W	01121	CB1005
R1282	315-0104-00			RES.,FXD,CMPSN:100K OHM,5%,0.25W	01121	CB1045
R1283	315-0470-00			RES.,FXD,CMPSN:47 OHM,5%,0.25W	01121	CB4705
R1284	321-0816-00			RES.,FXD,FILM:5K OHM,1%,0.125W	24546	NA55D5001F
R1286	321-0816-00			RES.,FXD,FILM:5K OHM,1%,0.125W	24546	NA55D5001F
R1288	321-0932-00			RES.,FXD,FILM:2.5K OHM,1%,0.125W	24546	NA55D2501F
R1292	321-0932-00			RES.,FXD,FILM:2.5K OHM,1%,0.125W	24546	NA55D2501F
R1294	321-0932-00			RES.,FXD,FILM:2.5K OHM,1%,0.125W	24546	NA55D2501F
R1296	315-0103-00			RES.,FXD,CMPSN:10K OHM,5%,0.25W	01121	CB1035
R1297	315-0390-00			RES.,FXD,CMPSN:39 OHM,5%,0.25W	01121	CB3905
R1298	321-0289-00			RES.,FXD,FILM:10K OHM,1%,0.125W	91637	MFF1816G10001F
R1299	315-0100-00			RES.,FXD,CMPSN:10 OHM,5%,0.25W	01121	CB1005
R1300	321-0303-00			RES.,FXD,FILM:14K OHM,1%,0.125W	91637	MFF1816G14001F
R1301	321-0289-00			RES.,FXD,FILM:10K OHM,1%,0.125W	91637	MFF1816G10001F
R1302	315-0153-00			RES.,FXD,CMPSN:15K OHM,5%,0.25W	01121	CB1535
R1303	321-0247-00			RES.,FXD,FILM:3.65K OHM,1%,0.125W	91637	MFF1816G36500F

Replaceable Electrical Parts—7L18 Service

Ckt No.	Tektronix Part No.	Serial/Model No. Eff	Dscont	Name & Description	Mfr Code	Mfr Part Number
R1304	321-0355-08			RES., FXD, FILM:48.7K OHM, 1%, 0.125W	24546	NC55C4872F
R1306	321-0781-06			RES., FXD, FILM:400K OHM, 0.25%, 0.125W	91637	MFF1816C40002C
R1308	311-1337-00			RES., VAR, NONWIR: 25K OHM, 10%, 0.50W	73138	89-129-1
R1310	321-0420-00			RES., FXD, FILM:232K OHM, 1%, 0.125W	91637	MFF1816G23202F
R1312	311-1337-00			RES., VAR, NONWIR: 25K OHM, 10%, 0.50W	73138	89-129-1
R1314	315-0105-00			RES., FXD, CMPSN:1M OHM, 5%, 0.25W	01121	CB1055
R1316	321-0282-00			RES., FXD, FILM:8.45K OHM, 1%, 0.125W	91637	MFF1816G84500F
R1318	321-0289-00			RES., FXD, FILM:10K OHM, 1%, 0.125W	91637	MFF1816G10001F
R1322	315-0104-00			RES., FXD, CMPSN:100K OHM, 5%, 0.25W	01121	CB1045
R1324	315-0103-00			RES., FXD, CMPSN:10K OHM, 5%, 0.25W	01121	CB1035
R1326	315-0103-00			RES., FXD, CMPSN:10K OHM, 5%, 0.25W	01121	CB1035
R1328	315-0103-00			RES., FXD, CMPSN:10K OHM, 5%, 0.25W	01121	CB1035
R1332	315-0103-00			RES., FXD, CMPSN:10K OHM, 5%, 0.25W	01121	CB1035
R1334	315-0103-00			RES., FXD, CMPSN:10K OHM, 5%, 0.25W	01121	CB1035
R1336	315-0103-00			RES., FXD, CMPSN:10K OHM, 5%, 0.25W	01121	CB1035
R1338	315-0104-00			RES., FXD, CMPSN:100K OHM, 5%, 0.25W	01121	CB1045
R1340	315-0104-00			RES., FXD, CMPSN:100K OHM, 5%, 0.25W	01121	CB1045
R1341	315-0470-00			RES., FXD, CMPSN:47 OHM, 5%, 0.25W	01121	CB4705
R1342	311-1337-00			RES., VAR, NONWIR: 25K OHM, 10%, 0.50W	73138	89-129-1
R1344	321-0469-04			RES., FXD, FILM:750K OHM, 0.1%, 0.125W	91637	MFF1816D75002B
R1346	321-0237-00			RES., FXD, FILM:2.87K OHM, 1%, 0.125W	91637	MFF1816G28700F
R1348	315-0100-00			RES., FXD, CMPSN:10 OHM, 5%, 0.25W	01121	CB1005
R1350	315-0390-00			RES., FXD, CMPSN:39 OHM, 5%, 0.25W	01121	CB3905
R1352	315-0431-00			RES., FXD, CMPSN:430 OHM, 5%, 0.25W	01121	CB4315
R1354	315-0431-00			RES., FXD, CMPSN:430 OHM, 5%, 0.25W	01121	CB4315
R1356	315-0203-00			RES., FXD, CMPSN:20K OHM, 5%, 0.25W	01121	CB2035
R1358	315-0200-00			RES., FXD, CMPSN:20 OHM, 5%, 0.25W	01121	CB2005
R1360	315-0300-00			RES., FXD, CMPSN:30 OHM, 5%, 0.25W	01121	CB3005
R1362	315-0300-00			RES., FXD, CMPSN:30 OHM, 5%, 0.25W	01121	CB3005
R1364	315-0200-00			RES., FXD, CMPSN:20 OHM, 5%, 0.25W	01121	CB2005
R1366	315-0203-00			RES., FXD, CMPSN:20K OHM, 5%, 0.25W	01121	CB2035
R1368	321-0097-07			RES., FXD, FILM:100 OHM, 0.1%, 0.125W	24546	NE55E1000B
R1370	321-0754-07			RES., FXD, FILM:900 OHM, 0.1%, 0.125W	91637	MFF1816C900ROB
R1372	308-0807-00			RES., FXD, WW:10 OHM, 0.1%, 0.25W	91637	RS1/4 B10RO0B
R1374	315-0104-00			RES., FXD, CMPSN:100K OHM, 5%, 0.25W	01121	CB1045
R1376	315-0104-00			RES., FXD, CMPSN:100K OHM, 5%, 0.25W	01121	CB1045
R1378	321-0895-07			RES., FXD, FILM:90 OHM, 0.1%, 0.125W	01121	0BD
R1380	315-0513-00			RES., FXD, CMPSN:51K OHM, 5%, 0.25W	01121	CB5135
R1382	321-0895-07			RES., FXD, FILM:90 OHM, 0.1%, 0.125W	01121	0BD
R1384	308-0772-00			RES., FXD, WW:9 OHM, 0.1%, 3W	91637	RS2B-B9R000B
R1386	321-1699-07			RES., FXD, FILM:99 OHM, 0.1%, 0.125W	91637	MFF1816C999RO0B
R1387	322-0704-07	B010100	B010115	RES., FXD, FILM:121.2 OHM, 0.1%, 0.25W	91637	MFF1421C121R2B
R1387	322-0097-00	B010116		RES., FXD, FILM:100 OHM, 1%, 0.25W	75042	CEBT0-1000F
R1388	308-0770-00			RES., FXD, WW:1 OHM, 0.1%, 3W	91637	RLS2B-6-B1R000B
R1389	311-1149-00	B010100	B010115	RES., VAR, NONWIR:50 OHM, 10%, 0.75W	73138	89-122-1
R1389	311-1488-00	B010116		RES., VAR, NONWIR:100 OHM, 10%, 0.75W	73138	89-135-1
R1390	315-0103-00			RES., FXD, CMPSN:10K OHM, 5%, 0.25W	01121	CB1035
R1391	315-0102-00			RES., FXD, CMPSN:1K OHM, 5%, 0.25W	01121	CB1025
R1392	315-0103-00			RES., FXD, CMPSN:10K OHM, 5%, 0.25W	01121	CB1035
R1393	321-0068-00			RES., FXD, FILM:49.9 OHM, 1%, 0.125W	91637	MFF1816G49R90F
R1394	315-0104-00			RES., FXD, CMPSN:100K OHM, 5%, 0.25W	01121	CB1045
R1395	321-0068-00			RES., FXD, FILM:49.9 OHM, 1%, 0.125W	91637	MFF1816G49R90F
R1396	315-0104-00			RES., FXD, CMPSN:100K OHM, 5%, 0.25W	01121	CB1045
R1398	315-0302-00			RES., FXD, CMPSN:3K OHM, 5%, 0.25W	01121	CB3025
R1402	315-0104-00			RES., FXD, CMPSN:100K OHM, 5%, 0.25W	01121	CB1045
R1404	315-0103-00			RES., FXD, CMPSN:10K OHM, 5%, 0.25W	01121	CB1035
R1406	315-0105-00			RES., FXD, CMPSN:1M OHM, 5%, 0.25W	01121	CB1055

Ckt No.	Tektronix Part No.	Serial/Model No. Eff	Dscont	Name & Description	Mfr Code	Mfr Part Number
R1410	315-0471-00			RES.,FXD,CMPSN:470 OHM,5%,0.25W	01121	CB4715
R1412	315-0123-00			RES.,FXD,CMPSN:12K OHM,5%,0.25W	01121	CB1235
R1414	315-0104-00			RES.,FXD,CMPSN:100K OHM,5%,0.25W	01121	CB1045
R1416	315-0203-00			RES.,FXD,CMPSN:20K OHM,5%,0.25W	01121	CB2035
R1420	315-0202-00			RES.,FXD,CMPSN:2K OHM,5%,0.25W	01121	CB2025
R1422	315-0102-00			RES.,FXD,CMPSN:1K OHM,5%,0.25W	01121	CB1025
R1424	315-0101-00			RES.,FXD,CMPSN:100 OHM,5%,0.25W	01121	CB1015
R1425	315-0102-00			RES.,FXD,CMPSN:1K OHM,5%,0.25W	01121	CB1025
R1426	315-0513-00			RES.,FXD,CMPSN:51K OHM,5%,0.25W	01121	CB5135
R1428	315-0103-00			RES.,FXD,CMPSN:10K OHM,5%,0.25W	01121	CB1035
R1432	315-0102-00			RES.,FXD,CMPSN:1K OHM,5%,0.25W	01121	CB1025
R1434	315-0105-00			RES.,FXD,CMPSN:1M OHM,5%,0.25W	01121	CB1055
R1438	321-0638-00			RES.,FXD,FILM:7.96K OHM,1%,0.125W	24546	NA55D7961F
R1442	321-0223-00			RES.,FXD,FILM:2.05K OHM,1%,0.125W	91637	MFF1816G20500F
R1444	315-0512-00			RES.,FXD,CMPSN:5.1K OHM,5%,0.25W	01121	CB5125
R1446	321-0289-00			RES.,FXD,FILM:10K OHM,1%,0.125W	91637	MFF1816G10001F
R1448	321-0351-00			RES.,FXD,FILM:44.2K OHM,1%,0.125W	91637	MFF1816G44201F
R1450	315-0433-00			RES.,FXD,CMPSN:43K OHM,5%,0.25W	01121	CB4335
R1452	315-0240-00			RES.,FXD,CMPSN:24 OHM,5%,0.25W	01121	CB2405
R1454	315-0184-00			RES.,FXD,CMPSN:180K OHM,5%,0.25W	01121	CB1845
R1455	315-0822-00			RES.,FXD,CMPSN:8.2K OHM,5%,0.25W	01121	CB8225
R1456	315-0752-00			RES.,FXD,CMPSN:7.5K OHM,5%,0.25W	01121	CB7525
R1458	315-0240-00			RES.,FXD,CMPSN:24 OHM,5%,0.25W	01121	CB2405
R1462	315-0103-00			RES.,FXD,CMPSN:10K OHM,5%,0.25W	01121	CB1035
R1464	315-0203-00			RES.,FXD,CMPSN:20K OHM,5%,0.25W	01121	CB2035
R1466	315-0393-00			RES.,FXD,CMPSN:39K OHM,5%,0.25W	01121	CB3935
R1468	315-0472-00			RES.,FXD,CMPSN:4.7K OHM,5%,0.25W	01121	CB4725
R1470	315-0472-00			RES.,FXD,CMPSN:4.7K OHM,5%,0.25W	01121	CB4725
R1471	315-0473-00			RES.,FXD,CMPSN:47K OHM,5%,0.25W	01121	CB4735
R1472	315-0204-00			RES.,FXD,CMPSN:200K OHM,5%,0.25W	01121	CB2045
R1473	315-0473-00			RES.,FXD,CMPSN:47K OHM,5%,0.25W	01121	CB4735
R1474	315-0472-00			RES.,FXD,CMPSN:4.7K OHM,5%,0.25W	01121	CB4725
R1476	315-0103-00			RES.,FXD,CMPSN:10K OHM,5%,0.25W	01121	CB1035
R1478	315-0103-00			RES.,FXD,CMPSN:10K OHM,5%,0.25W	01121	CB1035
R1480	315-0822-00			RES.,FXD,CMPSN:8.2K OHM,5%,0.25W	01121	CB8225
R1482	315-0103-00			RES.,FXD,CMPSN:10K OHM,5%,0.25W	01121	CB1035
R1484	315-0100-00			RES.,FXD,CMPSN:10 OHM,5%,0.25W	01121	CB1005
R1486	315-0103-00			RES.,FXD,CMPSN:10K OHM,5%,0.25W	01121	CB1035
R1488	315-0103-00			RES.,FXD,CMPSN:10K OHM,5%,0.25W	01121	CB1035
R1490	315-0302-00			RES.,FXD,CMPSN:3K OHM,5%,0.25W	01121	CB3025
R1492	315-0182-00			RES.,FXD,CMPSN:1.8K OHM,5%,0.25W	01121	CB1825
R1494	315-0471-00			RES.,FXD,CMPSN:470 OHM,5%,0.25W	01121	CB4715
R1496	315-0222-00			RES.,FXD,CMPSN:2.2K OHM,5%,0.25W	01121	CB2225
R1498	315-0100-00			RES.,FXD,CMPSN:10 OHM,5%,0.25W	01121	CB1005
R1500	315-0271-00			RES.,FXD,CMPSN:270 OHM,5%,0.25W	01121	CB2715
R1502	315-0682-00			RES.,FXD,CMPSN:6.8K OHM,5%,0.25W	01121	CB6825
R1504	321-0355-00			RES.,FXD,FILM:48.7K OHM,1%,0.125W	91637	MFF1816G48701F
R1508	321-0398-00			RES.,FXD,FILM:137K OHM,1%,0.125W	91637	MFF1816G13702F
R1510	315-0472-00			RES.,FXD,CMPSN:4.7K OHM,5%,0.25W	01121	CB4725
R1511	307-0442-00			RES.,FXD,FILM:BIAS OF 8	80009	307-0442-00
R1512	321-0227-00			RES.,FXD,FILM:2.26K OHM,1%,0.125W	91637	MFF1816G22600F
R1514	321-0193-00			RES.,FXD,FILM:1K OHM,1%,0.125W	91637	MFF1816G10000F
R1516	315-0510-00			RES.,FXD,CMPSN:51K OHM,5%,0.25W	01121	CB5105
R1518	315-0203-00			RES.,FXD,CMPSN:20K OHM,5%,0.25W	01121	CB2035
R1522	315-0513-00			RES.,FXD,CMPSN:51K OHM,5%,0.25W	01121	CB5135
R1524	315-0513-00			RES.,FXD,CMPSN:51K OHM,5%,0.25W	01121	CB5135
R1526	315-0622-00			RES.,FXD,CMPSN:6.2K OHM,5%,0.25W	01121	CB6225

Replaceable Electrical Parts—7L18 Service

Ckt No.	Tektronix Part No.	Serial/Model No. Eff	Dscont	Name & Description	Mfr Code	Mfr Part Number
R1529	315-0473-00			RES., FXD, CMPSN:47K OHM, 5%, 0.25W	01121	CB4735
R1530	321-0289-00			RES., FXD, FILM:10K OHM, 1%, 0.125W	91637	MFF1816G10001F
R1531	315-0473-00			RES., FXD, CMPSN:47K OHM, 5%, 0.25W	01121	CB4735
R1532	321-0351-00			RES., FXD, FILM:44.2K OHM, 1%, 0.125W	91637	MFF1816G44201F
R1534	315-0433-00			RES., FXD, CMPSN:43K OHM, 5%, 0.25W	01121	CB4335
R1535	321-0298-00			RES., FXD, FILM:12.4K OHM, 1%, 0.125W	91637	MFF1816G12401F
R1536	315-0104-00			RES., FXD, CMPSN:100K OHM, 5%, 0.25W	01121	CB1045
R1537	315-0433-00			RES., FXD, CMPSN:43K OHM, 5%, 0.25W	01121	CB4335
R1538	321-0391-00	B010100	B020259	RES., FXD, FILM:115K OHM, 1%, 0.125K	91637	MFF1816G11502F
R1538	321-0388-00	B020260		RES., FXD, FILM:107K OHM, 1%, 0.125W	91637	MFF1816G10702F
R1540	315-0473-00			RES., FXD, CMPSN:47K OHM, 5%, 0.25W	01121	CB4735
R1542	321-1706-01	B010100	B020259	RES., FXD FILM:56.5K OHM, 0.5%, 0.125W	91637	MFF1816G56501D
R1542	321-0355-08	B020260		RES., FXD, FILM:48.7K OHM, 1%, 0.125W	24546	NC55C4872F
R1544	321-0420-00	B010100	B020259	RES., FXD, FILM:232K OHM, 1%, 0.125W	91637	MFF1816G23202F
R1544	321-0418-02	B020260		RES., FXD, FILM:221K OHM, 0.5%, 0.125W	91637	MFF1816D22102D
R1546	321-1487-01			RES., FXD FILM:1.17M OHM, 0.5%, 0.125W	91637	HFF188G11703D
R1548	321-1707-01	B010100	B020259	RES., FXD, FILM:585K OHM, 0.5%, 0.125W	91637	MFF1816G58502D
R1548	321-0458-00	B020260		RES., FXD, FILM:576K OHM, 1%, 0.125W	91637	MFF1816G57602F
R1552	321-1516-01			RES., FXD, FILM:2.34 OHM, 0.5%, 0.125W	91637	HFF188G23403D
R1554	315-0221-00			RES., FXD, CMPSN:220 OHM, 5%, 0.25W	01121	CB2215
R1556	321-0342-00			RES., FXD, FILM:35.7K OHM, 1%, 0.125W	91637	MFF1816G35701F
R1558	315-0472-00			RES., FXD, CMPSN:4.7K OHM, 5%, 0.25W	01121	CB4725
R1562	315-0561-00			RES., FXD, CMPSN:560 OHM, 5%, 0.25W	01121	CB5615
R1564	321-0282-00			RES., FXD, FILM:8.45K OHM, 1%, 0.125W	91637	MFF1816G84500F
R1565	315-0561-00			RES., FXD, CMPSN:560 OHM, 5%, 0.25W	01121	CB5615
R1566	321-0271-00			RES., FXD, FILM:6.49K OHM, 1%, 0.125W	91637	MFF1816G64900F
R1568	315-0223-00			RES., FXD, CMPSN:22K OHM, 5%, 0.25W	01121	CB2235
R1569	307-0107-00			RES., FXD, CMPSN:5.6 OHM, 5%, 0.25W	01121	CB56G5
R1570	315-0913-00			RES., FXD, CMPSN:91K OHM, 5%, 0.25W	01121	CB9135
R1571	315-0682-00			RES., FXD, CMPSN:6.8K OHM, 5%, 0.25W	01121	CB6825
R1572	315-0104-00			RES., FXD, CMPSN:100K OHM, 5%, 0.25W	01121	CB1045
R1573	315-0433-00			RES., FXD, CMPSN:43K OHM, 5%, 0.25W	01121	CB4335
R1574	315-0201-00			RES., FXD, CMPSN:200 OHM, 5%, 0.25W	01121	CB2015
R1576	321-0691-00			RES., FXD, FILM:42.7K OHM, 0.5%, 0.125W	91637	MFF1816G42701D
R1578	321-0402-01			RES., FXD, FILM:150K OHM, 0.5%, 0.125W	91637	MFF1816G15002D
R1580	315-0221-00			RES., FXD, CMPSN:220 OHM, 5%, 0.25W	01121	CB2215
R1582	315-0221-00			RES., FXD, CMPSN:220 OHM, 5%, 0.25W	01121	CB2215
R1584	315-0753-00			RES., FXD, CMPSN:75K OHM, 5%, 0.25W	01121	CB7535
R1594	315-0391-00	B010100	B020259	RES., FXD, CMPSN:390 OHM, 5%, 0.25W	01121	CB3915
R1594	317-0202-00	B020260		RES., FXD, CMPSN:2K OHM, 5%, 0.125W	01121	BB2025
R1595	315-0105-00			RES., FXD, CMPSN:1M OHM, 5%, 0.25W	01121	CB1055
R1596	321-0673-07			RES., FXD, FILM:17K OHM, 0.1%, 0.125W	91637	MFF1816C17001B
R1597	321-0222-00	B010100	B020259	RES., FXD, FILM:2K OHM, 1%, 0.125W	91637	MFF1816G20000F
R1597	321-0289-00	B020260		RES., FXD, FILM:10K OHM, 1%, 0.125W	91637	MFF1816G10001F
R1598	321-0286-00			RES., FXD, FILM:9.31K OHM, 1%, 0.125W	91637	MFF1816G93100F
R1600	321-0311-00			RES., FXD, FILM:16.9K OHM, 1%, 0.125W	91637	MFF1816G16901F
R1602	321-0291-00			RES., FXD, FILM:10.5K OHM, 1%, 0.125W	91637	MFF1816G10501F
R1604	321-0271-00			RES., FXD, FILM:6.49K OHM, 1%, 0.125W	91637	MFF1816G64900F
R1606	321-0286-00			RES., FXD, FILM:9.31K OHM, 1%, 0.125W	91637	MFF1816G93100F
R1608	315-0101-00			RES., FXD, CMPSN:100 OHM, 5%, 0.25W	01121	CB1015
R1609	321-0209-00			RES., FXD, FILM:1.47K OHM, 1%, 0.125W	91637	MFF1816G14700F
R1610	315-0204-00			RES., FXD, CMPSN:200K OHM, 5%, 0.25W	01121	CB2045
R1612	315-0204-00			RES., FXD, CMPSN:200K OHM, 5%, 0.25W	01121	CB2045
R1614	315-0153-00			RES., FXD, CMPSN:15K OHM, 5%, 0.25W	01121	CB1535
R1616	321-0677-07			RES., FXD, FILM:30.4K OHM, 0.1%, 0.125W	91637	MFF1816C30401B
R1618	321-0264-07			RES., FXD, FILM:5.49K OHM, 0.1%, 0.125W	91637	MFF1816C54900B
R1620	321-0697-07			RES., FXD, FILM:18.9K OHM, 0.1%, 0.125W	91637	MFF1816C18901B

Ckt No.	Tektronix Part No.	Serial/Model No. Eff	Dscont	Name & Description	Mfr Code	Mfr Part Number
R1622	321-1698-07			RES., FXD, FILM: 170K OHM, 0.1%, 0.125W	91637	MFF1816C17002B
R1624	321-0248-00			RES., FXD, FILM: 3.74K OHM, 1%, 0.125W	91637	MFF1816G37400F
R1626	315-0682-00			RES., FXD, CMPSN: 6.8K OHM, 5%, 0.25W	01121	CB6825
R1632	321-0265-00			RES., FXD, FILM: 5.62K OHM, 1%, 0.125W	91637	MFF1816G56200F
R1634	315-0100-00			RES., FXD, CMPSN: 10 OHM, 5%, 0.25W	01121	CB1005
R1636	321-0816-00			RES., FXD, FILM: 5K OHM, 1%, 0.125W	24546	NA55D5001F
R1638	321-0816-00			RES., FXD, FILM: 5K OHM, 1%, 0.125W	24546	NA55D5001F
R1640	315-0822-00			RES., FXD, CMPSN: 8.2K OHM, 5%, 0.25W	01121	CB8225
R1642	315-0100-00			RES., FXD, CMPSN: 10 OHM, 5%, 0.25W	01121	CB1005
R1644	315-0473-00			RES., FXD, CMPSN: 47K OHM, 5%, 0.25W	01121	CB4735
R1646	315-0100-00			RES., FXD, CMPSN: 10 OHM, 5%, 0.25W	01121	CB1005
R1648	315-0473-00			RES., FXD, CMPSN: 47K OHM, 5%, 0.25W	01121	CB4735
R1649	315-0470-00			RES., FXD, CMPSN: 47 OHM, 5%, 0.25W	01121	CB4705
R1650	315-0100-00			RES., FXD, CMPSN: 10 OHM, 5%, 0.25W	01121	CB1005
R1652	315-0100-00			RES., FXD, CMPSN: 10 OHM, 5%, 0.25W	01121	CB1005
R1654	315-0100-00			RES., FXD, CMPSN: 10 OHM, 5%, 0.25W	01121	CB1005
R1656	315-0100-00			RES., FXD, CMPSN: 10 OHM, 5%, 0.25W	01121	CB1005
R1658	315-0511-00			RES., FXD, CMPSN: 510 OHM, 5%, 0.25W	01121	CB5115
R1660	315-0511-00			RES., FXD, CMPSN: 510 OHM, 5%, 0.25W	01121	CB5115
R1662	315-0511-00			RES., FXD, CMPSN: 510 OHM, 5%, 0.25W	01121	CB5115
R1664	315-0511-00			RES., FXD, CMPSN: 510 OHM, 5%, 0.25W	01121	CB5115
R1665	315-0623-00			RES., FXD, CMPSN: 62K OHM, 5%, 0.25W	01121	CB6235
R1666	315-0154-00			RES., FXD, CMPSN: 150K OHM, 5%, 0.25W	01121	CB1545
R1668	315-0513-00			RES., FXD, CMPSN: 51K OHM, 5%, 0.25W	01121	CB5135
R1670	315-0623-00			RES., FXD, CMPSN: 62K OHM, 5%, 0.25W	01121	CB6235
R1671	315-0154-00			RES., FXD, CMPSN: 150K OHM, 5%, 0.25W	01121	CB1545
R1672	315-0513-00			RES., FXD, CMPSN: 51K OHM, 5%, 0.25W	01121	CB5135
R1674	315-0513-00			RES., FXD, CMPSN: 51K OHM, 5%, 0.25W	01121	CB5135
R1675	315-0623-00			RES., FXD, CMPSN: 62K OHM, 5%, 0.25W	01121	CB6235
R1676	315-0154-00			RES., FXD, CMPSN: 150K OHM, 5%, 0.25W	01121	CB1545
R1678	315-0513-00			RES., FXD, CMPSN: 51K OHM, 5%, 0.25W	01121	CB5135
R1680	315-0623-00			RES., FXD, CMPSN: 62K OHM, 5%, 0.25W	01121	CB6235
R1681	315-0154-00			RES., FXD, CMPSN: 150K OHM, 5%, 0.25W	01121	CB1545
R1682	315-0513-00			RES., FXD, CMPSN: 51K OHM, 5%, 0.25W	01121	CB5135
R1684	315-0513-00			RES., FXD, CMPSN: 51K OHM, 5%, 0.25W	01121	CB5135
R1685	315-0623-00			RES., FXD, CMPSN: 62K OHM, 5%, 0.25W	01121	CB6235
R1686	315-0154-00			RES., FXD, CMPSN: 150K OHM, 5%, 0.25W	01121	CB1545
R1689	321-0399-00			RES., FXD, FILM: 140K OHM, 1%, 0.125W	91637	MFF1816G14002F
R1690	315-0623-00			RES., FXD, CMPSN: 62K OHM, 5%, 0.25W	01121	CB6235
R1691	321-0399-00			RES., FXD, FILM: 140K OHM, 1%, 0.125W	91637	MFF1816G14002F
R1693	321-0370-00			RES., FXD, FILM: 69.8K OHM, 1%, 0.125W	91637	MFF1816G69801F
R1694	315-0154-00			RES., FXD, CMPSN: 150K OHM, 5%, 0.25W	01121	CB1545
R1695	321-0341-00			RES., FXD, FILM: 34.8K OHM, 1%, 0.125W	91637	MFF1816G34801F
R1696	315-0222-00			RES., FXD, CMPSN: 2.2K OHM, 5%, 0.25W	01121	CB2225
R1697	321-0312-00			RES., FXD, FILM: 17.4K OHM, 1%, 0.125W	91637	MFF1816G17401F
R1699	321-0308-00			RES., FXD, FILM: 15.8K OHM, 1%, 0.125W	91637	MFF1816G15801F
R1702	315-0153-00			RES., FXD, CMPSN: 15K OHM, 5%, 0.25W	01121	CB1535
R1703	315-0103-00			RES., FXD, CMPSN: 10K OHM, 5%, 0.25W	01121	CB1035
R1704	315-0102-00	XB020320		RES., FXD, CMPSN: 1K OHM, 5%, 0.25W	01121	CB1025
R1705	315-0103-00			RES., FXD, CMPSN: 10K OHM, 5%, 0.25W	01121	CB1035
R1706	315-0364-00			RES., FXD, CMPSN: 360K OHM, 5%, 0.25W	01121	CB3645
R1707	315-0303-00			RES., FXD, CMPSN: 30K OHM, 5%, 0.25W	01121	CB3035
R1708	315-0103-00			RES., FXD, CMPSN: 10K OHM, 5%, 0.25W	01121	CB1035
R1710	315-0513-00			RES., FXD, CMPSN: 51K OHM, 5%, 0.25W	01121	CB5135
R1711	315-0154-00			RES., FXD, CMPSN: 150K OHM, 5%, 0.25W	01121	CB1545
R1712	321-0356-00			RES., FXD, FILM: 49.9K OHM, 1%, 0.125W	91637	MFF1816G49901F
R1713	315-0154-00			RES., FXD, CMPSN: 150K OHM, 5%, 0.25W	01121	CB1545

Replaceable Electrical Parts—7L18 Service

Ckt No.	Tektronix Part No.	Serial/Model No. Eff	Dscont	Name & Description	Mfr Code	Mfr Part Number
R1715	315-0513-00			RES., FXD, CMPSN: 51K OHM, 5%, 0.25W	01121	CB5135
R1717	315-0154-00			RES., FXD, CMPSN: 150K OHM, 5%, 0.25W	01121	CB1545
R1718	321-0327-00			RES., FXD, FILM: 24.9K OHM, 1%, 0.125W	91637	MFF1816G24901F
R1719	315-0154-00			RES., FXD, CMPSN: 150K OHM, 5%, 0.25W	01121	CB1545
R1720	315-0513-00			RES., FXD, CMPSN: 51K OHM, 5%, 0.25W	01121	CB5135
R1721	315-0511-00			RES., FXD, CMPSN: 510 OHM, 5%, 0.25W	01121	CB5115
R1722	315-0154-00			RES., FXD, CMPSN: 150K OHM, 5%, 0.25W	01121	CB1545
R1724	315-0154-00			RES., FXD, CMPSN: 150K OHM, 5%, 0.25W	01121	CB1545
R1725	315-0513-00			RES., FXD, CMPSN: 51K OHM, 5%, 0.25W	01121	CB5135
R1726	321-0315-00			RES., FXD, FILM: 18.7K OHM, 1%, 0.125W	91637	CMF55-116G18701F
R1727	315-0154-00			RES., FXD, CMPSN: 150K OHM, 5%, 0.25W	01121	CB1545
R1728	315-0511-00			RES., FXD, CMPSN: 510 OHM, 5%, 0.25W	01121	CB5115
R1729	315-0154-00			RES., FXD, CMPSN: 150K OHM, 5%, 0.25W	01121	CB1545
R1730	315-0513-00			RES., FXD, CMPSN: 51K OHM, 5%, 0.25W	01121	CB5135
R1732	315-0154-00			RES., FXD, CMPSN: 150K OHM, 5%, 0.25W	01121	CB1545
R1733	321-0356-00			RES., FXD, FILM: 49.9K OHM, 1%, 0.125W	91637	MFF1816G49901F
R1734	315-0154-00			RES., FXD, CMPSN: 150K OHM, 5%, 0.25W	01121	CB1545
R1736	315-0511-00			RES., FXD, CMPSN: 510 OHM, 5%, 0.25W	01121	CB5115
R1737	321-0335-00			RES., FXD, FILM: 30.1K OHM, 1%, 0.125W	91637	MFF1816G30101F
R1739	321-0344-00			RES., FXD, FILM: 37.4K OHM, 1%, 0.125W	91637	MFF1816G37401F
R1741	315-0511-00			RES., FXD, CMPSN: 510 OHM, 5%, 0.25W	01121	CB5115
R1742	321-0344-00			RES., FXD, FILM: 37.4K OHM, 1%, 0.125W	91637	MFF1816G37401F
R1744	321-0335-00			RES., FXD, FILM: 30.1K OHM, 1%, 0.125W	91637	MFF1816G30101F
R1745	315-0511-00			RES., FXD, CMPSN: 510 OHM, 5%, 0.25W	01121	CB5115
R1747	307-0499-00			RES., FXD, FILM: 100K OHM, 5%, 0.125W	91637	MSP10A01104J
R1749	315-0104-00			RES., FXD, CMPSN: 100K OHM, 5%, 0.25W	01121	CB1045
R1750	315-0103-00			RES., FXD, CMPSN: 10K OHM, 5%, 0.25W	01121	CB1035
R1751	315-0303-00			RES., FXD, CMPSN: 30K OHM, 5%, 0.25W	01121	CB3035
R1752	315-0103-00			RES., FXD, CMPSN: 10K OHM, 5%, 0.25W	01121	CB1035
R1753	315-0511-00			RES., FXD, CMPSN: 510 OHM, 5%, 0.25W	01121	CB5115
R1754	315-0511-00			RES., FXD, CMPSN: 510 OHM, 5%, 0.25W	01121	CB5115
R1755	315-0511-00			RES., FXD, CMPSN: 510 OHM, 5%, 0.25W	01121	CB5115
R1756	315-0511-00			RES., FXD, CMPSN: 510 OHM, 5%, 0.25W	01121	CB5115
R1757	315-0511-00			RES., FXD, CMPSN: 510 OHM, 5%, 0.25W	01121	CB5115
R1758	315-0432-00			RES., FXD, CMPSN: 4.3K OHM, 5%, 0.25W	01121	CB4325
R1760	315-0622-00			RES., FXD, CMPSN: 6.2K OHM, 5%, 0.25W	01121	CB6225
R1762	315-0153-00			RES., FXD, CMPSN: 15K OHM, 5%, 0.25W	01121	CB1535
R1763	315-0432-00			RES., FXD, CMPSN: 4.3K OHM, 5%, 0.25W	01121	CB4325
R1764	315-0622-00			RES., FXD, CMPSN: 6.2K OHM, 5%, 0.25W	01121	CB6225
R1766	315-0153-00			RES., FXD, CMPSN: 15K OHM, 5%, 0.25W	01121	CB1535
R1767	315-0432-00			RES., FXD, CMPSN: 4.3K OHM, 5%, 0.25W	01121	CB4325
R1768	315-0622-00			RES., FXD, CMPSN: 6.2K OHM, 5%, 0.25W	01121	CB6225
R1770	315-0153-00			RES., FXD, CMPSN: 15K OHM, 5%, 0.25W	01121	CB1535
R1771	315-0432-00			RES., FXD, CMPSN: 4.3K OHM, 5%, 0.25W	01121	CB4325
R1772	315-0622-00			RES., FXD, CMPSN: 6.2K OHM, 5%, 0.25W	01121	CB6225
R1774	315-0153-00			RES., FXD, CMPSN: 15K OHM, 5%, 0.25W	01121	CB1535
R1775	315-0432-00			RES., FXD, CMPSN: 4.3K OHM, 5%, 0.25W	01121	CB4325
R1776	315-0622-00			RES., FXD, CMPSN: 6.2K OHM, 5%, 0.25W	01121	CB6225
R1778	315-0153-00			RES., FXD, CMPSN: 15K OHM, 5%, 0.25W	01121	CB1535
R1782	315-0202-00			RES., FXD, CMPSN: 2K OHM, 5%, 0.25W	01121	CB2025
R1785	315-0513-00			RES., FXD, CMPSN: 51K OHM, 5%, 0.25W	01121	CB5135
R1786	315-0623-00			RES., FXD, CMPSN: 62K OHM, 5%, 0.25W	01121	CB6235
R1788	315-0154-00			RES., FXD, CMPSN: 150K OHM, 5%, 0.25W	01121	CB1545
R1789	315-0513-00			RES., FXD, CMPSN: 51K OHM, 5%, 0.25W	01121	CB5135
R1790	315-0623-00			RES., FXD, CMPSN: 62K OHM, 5%, 0.25W	01121	CB6235
R1792	315-0154-00			RES., FXD, CMPSN: 150K OHM, 5%, 0.25W	01121	CB1545
R1793	315-0513-00			RES., FXD, CMPSN: 51K OHM, 5%, 0.25W	01121	CB5135

Ckt No.	Tektronix Part No.	Serial/Model No. Eff	Dscont	Name & Description	Mfr Code	Mfr Part Number
R1794	315-0623-00			RES.,FXD,CMPSN:62K OHM,5%,0.25W	01121	CB6235
R1796	315-0154-00			RES.,FXD,CMPSN:150K OHM,5%,0.25W	01121	CB1545
R1797	315-0513-00			RES.,FXD,CMPSN:51K OHM,5%,0.25W	01121	CB5135
R1798	315-0623-00			RES.,FXD,CMPSN:62K OHM,5%,0.25W	01121	CB6235
R1800	315-0154-00			RES.,FXD,CMPSN:150K OHM,5%,0.25W	01121	CB1545
R1801	315-0513-00			RES.,FXD,CMPSN:51K OHM,5%,0.25W	01121	CB5135
R1802	315-0623-00			RES.,FXD,CMPSN:62K OHM,5%,0.25W	01121	CB6235
R1804	315-0154-00			RES.,FXD,CMPSN:150K OHM,5%,0.25W	01121	CB1545
R1805	315-0513-00			RES.,FXD,CMPSN:51K OHM,5%,0.25W	01121	CB5135
R1806	315-0623-00			RES.,FXD,CMPSN:62K OHM,5%,0.25W	01121	CB6235
R1807	315-0222-00			RES.,FXD,CMPSN:2.2K OHM,5%,0.25W	01121	CB2225
R1808	315-0154-00			RES.,FXD,CMPSN:150K OHM,5%,0.25W	01121	CB1545
R1809	315-0513-00			RES.,FXD,CMPSN:51K OHM,5%,0.25W	01121	CB5135
R1810	315-0623-00			RES.,FXD,CMPSN:62K OHM,5%,0.25W	01121	CB6235
R1812	315-0154-00			RES.,FXD,CMPSN:150K OHM,5%,0.25W	01121	CB1545
R1814	321-0399-00			RES.,FXD,FILM:140K OHM,1%,0.125W	91637	MFF1816G14002F
R1815	321-0333-00			RES.,FXD,FILM:28.7K OHM,1%,0.125W	91637	MFF1816G28701F
R1816	321-0399-00			RES.,FXD,FILM:140K OHM,1%,0.125W	91637	MFF1816G14002F
R1817	321-0370-00			RES.,FXD,FILM:69.8K OHM,1%,0.125W	91637	MFF1816G69801F
R1818	321-0341-00			RES.,FXD,FILM:34.8K OHM,1%,0.125W	91637	MFF1816G34801F
R1819	321-0312-00			RES.,FXD,FILM:17.4K OHM,1%,0.125W	91637	MFF1816G17401F
R1820	321-0373-00			RES.,FXD,FILM:75K OHM,1%,0.125W	91637	MFF1816G75001F
R1821	321-0305-00			RES.,FXD,FILM:14.7K OHM,1%,0.125W	91637	MFF1816G14701F
R1822	321-0399-00			RES.,FXD,FILM:140K OHM,1%,0.125W	91637	MFF1816G14002F
R1823	321-0402-00			RES.,FXD,FILM:150K OHM,1%,0.125W	24546	NA55D1503F
R1824	321-0327-00			RES.,FXD,FILM:24.9K OHM,1%,0.125W	91637	MFF1816G24901F
R1825	321-0344-00			RES.,FXD,FILM:37.4K OHM,1%,0.125W	91637	MFF1816G37401F
R1826	321-0321-00			RES.,FXD,FILM:21.5K OHM,1%,0.125W	91637	MFF1816G21501F
R1827	321-0344-00			RES.,FXD,FILM:37.4K OHM,1%,0.125W	91637	MFF1816G37401F
R1828	321-0402-00			RES.,FXD,FILM:150K OHM,1%,0.125W	24546	NA55D1503F
R1829	321-0356-00			RES.,FXD,FILM:49.9K OHM,1%,0.125W	91637	MFF1816G49901F
R1830	321-0308-00			RES.,FXD,FILM:15.8K OHM,1%,0.125W	91637	MFF1816G15801F
R1836	321-0402-00			RES.,FXD,FILM:150K OHM,1%,0.125W	24546	NA55D1503F
R1837	321-0402-00			RES.,FXD,FILM:150K OHM,1%,0.125W	24546	NA55D1503F
R1838	321-0327-00			RES.,FXD,FILM:24.9K OHM,1%,0.125W	91637	MFF1816G24901F
R1839	321-0320-00			RES.,FXD,FILM:21K OHM,1%,0.125W	91637	MFF1816G21001F
R1840	321-0344-00			RES.,FXD,FILM:37.4K OHM,1%,0.125W	91637	MFF1816G37401F
R1842	321-0356-00			RES.,FXD,FILM:49.9K OHM,1%,0.125W	91637	MFF1816G49901F
R1844	321-0335-00			RES.,FXD,FILM:30.1K OHM,1%,0.125W	91637	MFF1816G30101F
R1846	321-0344-00			RES.,FXD,FILM:37.4K OHM,1%,0.125W	91637	MFF1816G37401F
R1848	321-0344-00			RES.,FXD,FILM:37.4K OHM,1%,0.125W	91637	MFF1816G37401F
R1850	321-0335-00			RES.,FXD,FILM:30.1K OHM,1%,0.125W	91637	MFF1816G30101F
R1852	321-0310-00			RES.,FXD,FILM:16.5K OHM,1%,0.125W	91637	MFF1816G16501F
R1854	321-0306-00			RES.,FXD,FILM:15K OHM,1%,0.125W	91637	MFF1816G15001F
R1856	321-0356-00			RES.,FXD,FILM:49.9K OHM,1%,0.125W	91637	MFF1816G49901F
R1858	321-0306-00			RES.,FXD,FILM:15K OHM,1%,0.125W	91637	MFF1816G15001F
R1860	321-0344-00			RES.,FXD,FILM:37.4K OHM,1%,0.125W	91637	MFF1816G37401F
R1862	321-0402-00			RES.,FXD,FILM:150K OHM,1%,0.125W	24546	NA55D1503F
R1864	321-0344-00			RES.,FXD,FILM:37.4K OHM,1%,0.125W	91637	MFF1816G37401F
R1896	321-0304-00			RES.,FXD,FILM:14.3K OHM,1%,0.125W	91637	MFF1816G14301F
R1898	321-0402-00			RES.,FXD,FILM:150K OHM,1%,0.125W	24546	NA55D1503F
R1900	321-0373-00			RES.,FXD,FILM:75K OHM,1%,0.125W	91637	MFF1816G75001F
R1902	321-0373-00			RES.,FXD,FILM:75K OHM,1%,0.125W	91637	MFF1816G75001F
R1904	321-0356-00			RES.,FXD,FILM:49.9K OHM,1%,0.125W	91637	MFF1816G49901F
R1906	321-0327-00			RES.,FXD,FILM:24.9K OHM,1%,0.125W	91637	MFF1816G24901F
R1908	321-0327-00			RES.,FXD,FILM:24.9K OHM,1%,0.125W	91637	MFF1816G24901F
R1910	321-0320-00			RES.,FXD,FILM:21K OHM,1%,0.125W	91637	MFF1816G21001F

Replaceable Electrical Parts—7L18 Service

Ckt No.	Tektronix Part No.	Serial/Model No. Eff	Dscont	Name & Description	Mfr Code	Mfr Part Number
R1912	321-0402-00			RES., FXD, FILM:150K OHM, 1%, 0.125W	24546	NA55D1503F
R1914	321-0373-00			RES., FXD, FILM:75K OHM, 1%, 0.125W	91637	MFF1816G75001F
R1916	321-0402-00			RES., FXD, FILM:150K OHM, 1%, 0.125W	24546	NA55D1503F
R1918	321-0335-00			RES., FXD, FILM:30.1K OHM, 1%, 0.125W	91637	MFF1816G30101F
R1920	321-0356-00			RES., FXD, FILM:49.9K OHM, 1%, 0.125W	91637	MFF1816G49901F
R1922	321-0335-00			RES., FXD, FILM:30.1K OHM, 1%, 0.125W	91637	MFF1816G30101F
R1923	321-0344-00			RES., FXD, FILM:37.4K OHM, 1%, 0.125W	91637	MFF1816G37401F
R1924	321-0373-00			RES., FXD, FILM:75K OHM, 1%, 0.125W	91637	MFF1816G75001F
R1925	321-0373-00			RES., FXD, FILM:75K OHM, 1%, 0.125W	91637	MFF1816G75001F
R1926	321-0356-00			RES., FXD, FILM:49.9K OHM, 1%, 0.125W	91637	MFF1816G49901F
R1927	321-0344-00			RES., FXD, FILM:37.4K OHM, 1%, 0.125W	91637	MFF1816G37401F
R1928	321-0356-00			RES., FXD, FILM:49.9K OHM, 1%, 0.125W	91637	MFF1816G49901F
R1961	315-0100-00			RES., FXD, CMPSN:10 OHM, 5%, 0.25W	01121	CB1005
R1962	311-1339-00			RES., VAR, NONWIR:5K OHM, 10%, 0.50W	73138	89-131-1
R1964	325-0272-00			RES., FXD, FILM:67.1K OHM, 0.25%, 0.3W	07088	K747 67.1 K OHM
R1966	325-0261-00			RES., FXD, FILM:8.29K OHM, 0.25%, 0.3W	07088	K747 8.29 K OHM
R1968	311-1339-00			RES., VAR, NONWIR:5K OHM, 10%, 0.50W	73138	89-131-1
R1969	315-0102-00			RES., FXD, CMPSN:1K OHM, 5%, 0.25W	01121	CB1025
R1970	325-0272-00			RES., FXD, FILM:67.1K OHM, 0.25%, 0.3W	07088	K747 67.1 K OHM
R1972	325-0261-00			RES., FXD, FILM:8.29K OHM, 0.25%, 0.3W	07088	K747 8.29 K OHM
R1973	315-0393-00			RES., FXD, CMPSN:39K OHM, 5%, 0.25W	01121	CB3935
R1974	311-1339-00			RES., VAR, NONWIR:5K OHM, 10%, 0.50W	73138	89-131-1
R1976	325-0272-00			RES., FXD, FILM:67.1K OHM, 0.25%, 0.3W	07088	K747 67.1 K OHM
R1978	325-0261-00			RES., FXD, FILM:8.29K OHM, 0.25%, 0.3W	07088	K747 8.29 K OHM
R1980	311-1339-00			RES., VAR, NONWIR:5K OHM, 10%, 0.50W	73138	89-131-1
R1982	325-0272-00			RES., FXD, FILM:67.1K OHM, 0.25%, 0.3W	07088	K747 67.1 K OHM
R1984	325-0261-00			RES., FXD, FILM:8.29K OHM, 0.25%, 0.3W	07088	K747 8.29 K OHM
R1986	311-1339-00			RES., VAR, NONWIR:5K OHM, 10%, 0.50W	73138	89-131-1
R1988	325-0272-00			RES., FXD, FILM:67.1K OHM, 0.25%, 0.3W	07088	K747 67.1 K OHM
R1990	325-0261-00			RES., FXD, FILM:8.29K OHM, 0.25%, 0.3W	07088	K747 8.29 K OHM
R1992	325-0267-00			RES., FXD, FILM:21.7K OHM, 0.25%, 0.3W	07088	K747 21.7 K OHM
R1994	325-0265-00			RES., FXD, FILM:15.6K OHM, 0.25%, 0.3W	07088	K747 15.6 K OHM
R1996	325-0262-00			RES., FXD, FILM:9.79K OHM, 0.25%, 0.3W	07088	K747 9.79 K OHM
R1998	325-0258-00			RES., FXD, FILM:5.62K OHM, 0.25%, 0.3W	07088	K747 5.62 K OHM
R2000	325-0255-00			RES., FXD, FILM:3.75K OHM, 0.25%, 0.3W	07088	K747 3.75K OHM
R2002	325-0268-00			RES., FXD, FILM:17.8K OHM, 0.25%, 0.3W	07088	K747 17.8 K OHM
R2004	315-0390-00			RES., FXD, CMPSN:39 OHM, 5%, 0.25W	01121	CB3905
R2006	315-0100-00			RES., FXD, CMPSN:10 OHM, 5%, 0.25W	01121	CB1005
R2008	311-1339-00			RES., VAR, NONWIR:5K OHM, 10%, 0.50W	73138	89-131-1
R2010	325-0272-00			RES., FXD, FILM:67.1K OHM, 0.25%, 0.3W	07088	K747 67.1 K OHM
R2012	325-0261-00			RES., FXD, FILM:8.29K OHM, 0.25%, 0.3W	07088	K747 8.29 K OHM
R2014	311-1339-00			RES., VAR, NONWIR:5K OHM, 10%, 0.50W	73138	89-131-1
R2016	325-0272-00			RES., FXD, FILM:67.1K OHM, 0.25%, 0.3W	07088	K747 67.1 K OHM
R2018	325-0261-00			RES., FXD, FILM:8.29K OHM, 0.25%, 0.3W	07088	K747 8.29 K OHM
R2019	315-0472-00			RES., FXD, CMPSN:4.7K OHM, 5%, 0.25W	01121	CB4725
R2020	311-1339-00			RES., VAR, NONWIR:5K OHM, 10%, 0.50W	73138	89-131-1
R2022	325-0272-00			RES., FXD, FILM:67.1K OHM, 0.25%, 0.3W	07088	K747 67.1 K OHM
R2023	315-0102-00			RES., FXD, CMPSN:1K OHM, 5%, 0.25W	01121	CB1025
R2024	325-0261-00			RES., FXD, FILM:8.29K OHM, 0.25%, 0.3W	07088	K747 8.29 K OHM
R2026	311-1339-00			RES., VAR, NONWIR:5K OHM, 10%, 0.50W	73138	89-131-1
R2028	325-0272-00			RES., FXD, FILM:67.1K OHM, 0.25%, 0.3W	07088	K747 67.1 K OHM
R2030	325-0261-00			RES., FXD, FILM:8.29K OHM, 0.25%, 0.3W	07088	K747 8.29 K OHM
R2032	311-1339-00			RES., VAR, NONWIR:5K OHM, 10%, 0.50W	73138	89-131-1
R2034	325-0272-00			RES., FXD, FILM:67.1K OHM, 0.25%, 0.3W	07088	K747 67.1 K OHM
R2036	325-0261-00			RES., FXD, FILM:8.29K OHM, 0.25%, 0.3W	07088	K747 8.29 K OHM
R2038	325-0271-00			RES., FXD, FILM:51.1K OHM, 0.25%, 0.3W	07088	K747 51.1 K OHM
R2040	325-0271-00			RES., FXD, FILM:51.1K OHM, 0.25%, 0.3W	07088	K747 51.1 K OHM

Replaceable Electrical Parts—7L18 Service

Ckt No.	Tektronix Part No.	Serial/Model No. Eff Dscont	Name & Description	Mfr Code	Mfr Part Number
R2042	325-0270-00		RES., FXD, FILM: 25.7K OHM, 0.25%, 0.3W	07088	K747 25.7 K OHM
R2044	325-0266-00		RES., FXD, FILM: 17.2K OHM, 0.25%, 0.3W	07088	K747 17.2 K OHM
R2046	325-0264-00		RES., FXD, FILM: 10.43K OHM, 0.25%, 0.3W	07088	K747 10.43K OHM
R2047	311-1271-00		RES., VAR, NONWIR: 50K OHM, 10%, 0.50W	32997	3329P-L58-503
R2048	315-0225-00		RES., FXD, CMPSN: 2.2M OHM, 5%, 0.25W	01121	CB2255
R2049	321-0469-04		RES., FXD, FILM: 750K OHM, 0.1%, 0.125W	91637	MFF1816D75002B
R2056	325-0259-00		RES., FXD, FILM: 6.77K OHM, 0.5%, 0.3W	07088	K747 6.77K OHM
R2058	325-0257-00		RES., FXD, FILM: 1.09K OHM, 0.5%, 0.3W	07088	K747 1.09K OHM
R2061	315-0102-00		RES., FXD, CMPSN: 1K OHM, 5%, 0.25W	01121	CB1025
R2062	321-0753-06		RES., FXD, FILM: 9K OHM, 0.25%, 0.125W	91637	MFF1816C90000C
R2063	315-0222-00		RES., FXD, CMPSN: 2.2K OHM, 5%, 0.25W	01121	CB2225
R2064	321-0753-06		RES., FXD, FILM: 9K OHM, 0.25%, 0.125W	91637	MFF1816C90000C
R2066	311-1264-00		RES., VAR, NONWIR: 1.5K OHM, 10%, 0.50W	32997	3329P-L58-152
R2068	315-0512-00		RES., FXD, CMPSN: 5.1K OHM, 5%, 0.25W	01121	CB5125
R2069	321-0381-00		RES., FXD, FILM: 90.9K OHM, 1%, 0.125W	91637	MFF1816G90901F
R2070	315-0102-00		RES., FXD, CMPSN: 1K OHM, 5%, 0.25W	01121	CB1025
R2071	321-0289-00		RES., FXD, FILM: 10K OHM, 1%, 0.125W	91637	MFF1816G10001F
R2072	311-1339-00		RES., VAR, NONWIR: 5K OHM, 10%, 0.50W	73138	89-131-1
R2074	310-0705-00		RES., FXD, WW: 3 OHM, 0.25%, 2W	80009	310-0705-00
R2075	315-0102-00		RES., FXD, CMPSN: 1K OHM, 5%, 0.25W	01121	CB1025
R2096	315-0105-00		RES., FXD, CMPSN: 1M OHM, 5%, 0.25W	01121	CB1055
R2126	321-0473-00		RES., FXD, FILM: 825K OHM, 1%, 0.125W	91637	MFF1816G82502F
R2128	321-0316-00		RES., FXD, FILM: 19.1K OHM, 1%, 0.125W	91637	MFF1816G19101F
R2132	315-0105-00		RES., FXD, CMPSN: 1M OHM, 5%, 0.25W	01121	CB1055
R2134	315-0274-00		RES., FXD, CMPSN: 270K OHM, 5%, 0.25W	01121	CB2745
R2136	315-0473-00		RES., FXD, CMPSN: 47K OHM, 5%, 0.25W	01121	CB4735
R2138	315-0153-00		RES., FXD, CMPSN: 15K OHM, 5%, 0.25W	01121	CB1535
R2142	315-0274-00		RES., FXD, CMPSN: 270K OHM, 5%, 0.25W	01121	CB2745
R2144	315-0105-00		RES., FXD, CMPSN: 1M OHM, 5%, 0.25W	01121	CB1055
R2150	321-0328-00		RES., FXD, FILM: 25.5K OHM, 1%, 0.125W	91637	MFF1816G25501F
R2152	321-0266-00		RES., FXD, FILM: 5.76K OHM, 1%, 0.125W	91637	MFF1816G57600F
R2154	325-0268-00		RES., FXD, FILM: 17.8K OHM, 0.25%, 0.3W	07088	K747 17.8 K OHM
R2156	321-0328-00		RES., FXD, FILM: 25.5K OHM, 1%, 0.125W	91637	MFF1816G25501F
R2160	321-0270-00		RES., FXD, FILM: 6.34K OHM, 1%, 0.125W	91637	MFF1816G63400F
R2162	315-0390-00		RES., FXD, CMPSN: 39 OHM, 5%, 0.25W	01121	CB3905
R2164	315-0100-00		RES., FXD, CMPSN: 10 OHM, 5%, 0.25W	01121	CB1005
R2168	325-0269-00		RES., FXD, FILM: 22K OHM, 1%, 0.3W	07088	K747 22 K OHM 1%
R2170	321-0376-09		RES., FXD, FILM: 80.6K OHM, 1%, 0.125W	91637	MFF1816C80601F
R2172	311-1337-00		RES., VAR, NONWIR: 25K OHM, 10%, 0.50W	73138	89-129-1
R2174	325-0260-00		RES., FXD, FILM: 7.26K OHM, 1%, 0.3W	07088	K747 7.26KOHM 1%
R2176	311-1319-00		RES., VAR, NONWIR: 10K OHM, 10%, 0.75W	73138	89-126-1
R2178	321-1329-03		RES., FXD, FILM: 26.4K OHM, 0.25%, 0.125W	91637	MFF1816D26401C
R2180	321-0097-07		RES., FXD, FILM: 100 OHM, 0.1%, 0.125W	24546	NE55E1000B
R2182	325-0256-00		RES., FXD, FILM: 3.42K OHM, 1%, 0.3W	07088	K747 3.42KOHM 1%
R2184	310-0704-00		RES., FXD, WW: 35 OHM, 0.5%, 2W	80009	310-0704-00
R2186	321-0241-00		RES., FXD, FILM: 3.16K OHM, 1%, 0.125W	91637	MFF1816G31600F
R2194	315-0222-00		RES., FXD, CMPSN: 2.2K OHM, 5%, 0.25W	01121	CB2225
R2196	315-0123-00		RES., FXD, CMPSN: 12K OHM, 5%, 0.25W	01121	CB1235
R2198	315-0102-00		RES., FXD, CMPSN: 1K OHM, 5%, 0.25W	01121	CB1025
R2202	315-0104-00		RES., FXD, CMPSN: 100K OHM, 5%, 0.25W	01121	CB1045
R2204	315-0623-00		RES., FXD, CMPSN: 62K OHM, 5%, 0.25W	01121	CB6235
R2206	315-0393-00		RES., FXD, CMPSN: 39K OHM, 5%, 0.25W	01121	CB3935
R2208	315-0104-00		RES., FXD, CMPSN: 100K OHM, 5%, 0.25W	01121	CB1045
R2212	315-0274-00		RES., FXD, CMPSN: 270K OHM, 5%, 0.25W	01121	CB2745
R2222	315-0274-00		RES., FXD, CMPSN: 270K OHM, 5%, 0.25W	01121	CB2745
R2224	315-0105-00		RES., FXD, CMPSN: 1M OHM, 5%, 0.25W	01121	CB1055
R2226	315-0274-00		RES., FXD, CMPSN: 270K OHM, 5%, 0.25W	01121	CB2745

Replaceable Electrical Parts—7L18 Service

Ckt No.	Tektronix Part No.	Serial/Model No. Eff Dscont	Name & Description	Mfr Code	Mfr Part Number
R2228	315-0105-00		RES., FXD, CMPSN: 1M OHM, 5%, 0.25W	01121	CB1055
R2234	321-0386-07		RES., FXD, FILM: 102K OHM, 0.1%, 0.125W	91637	MFF1816C10202B
R2238	321-0289-07		RES., FXD, FILM: 10K OHM, 0.1%, 0.125W	91637	MFF1816C10001B
R2242	315-0513-00		RES., FXD, CMPSN: 51K OHM, 5%, 0.25W	01121	CB5135
R2244	315-0302-00		RES., FXD, CMPSN: 3K OHM, 5%, 0.25W	01121	CB3025
R2246	315-0182-00		RES., FXD, CMPSN: 1.8K OHM, 5%, 0.25W	01121	CB1825
R2248	315-0101-00		RES., FXD, CMPSN: 100 OHM, 5%, 0.25W	01121	CB1015
R2252	321-0274-00		RES., FXD, FILM: 6.98K OHM, 1%, 0.125W	91637	MFF1816G69800F
R2254	315-0514-00		RES., FXD, CMPSN: 510K OHM, 5%, 0.25W	01121	CB5145
R2256	315-0182-00		RES., FXD, CMPSN: 1.8K OHM, 5%, 0.25W	01121	CB1825
R2258	315-0182-00		RES., FXD, CMPSN: 1.8K OHM, 5%, 0.25W	01121	CB1825
R2260	315-0514-00		RES., FXD, CMPSN: 510K OHM, 5%, 0.25W	01121	CB5145
R2261	321-0257-00		RES., FXD, FILM: 4.64K OHM, 1%, 0.125W	91637	MFF1816G46400F
R2262	315-0153-00		RES., FXD, CMPSN: 15K OHM, 5%, 0.25W	01121	CB1535
R2264	315-0153-00		RES., FXD, CMPSN: 15K OHM, 5%, 0.25W	01121	CB1535
R2266	315-0104-00		RES., FXD, CMPSN: 100K OHM, 5%, 0.25W	01121	CB1045
R2268	315-0102-00		RES., FXD, CMPSN: 1K OHM, 5%, 0.25W	01121	CB1025
R2270	321-0310-00		RES., FXD, FILM: 16.5K OHM, 1%, 0.125W (NOMINAL VALUE, SELECTED)	91637	MFF1816G16501F
R2271	321-0212-00		RES., FXD, FILM: 1.58K OHM, 1%, 0.125W	91637	MFF1816G15800F
R2272	315-0103-00		RES., FXD, CMPSN: 10K OHM, 5%, 0.25W	01121	CB1035
R2274	321-0233-00		RES., FXD, FILM: 2.61K OHM, 1%, 0.125W	91637	MFF1816G26100F
R2276	321-0238-00		RES., FXD, FILM: 2.94K OHM, 1%, 0.125W (NOMINAL VALUE, SELECTED)	91637	MFF1816G29400F
R2278	315-0302-00		RES., FXD, CMPSN: 3K OHM, 5%, 0.25W	01121	CB3025
R2280	315-0100-00		RES., FXD, CMPSN: 10 OHM, 5%, 0.25W	01121	CB1005
R2282	315-0182-00		RES., FXD, CMPSN: 1.8K OHM, 5%, 0.25W	01121	CB1825
R2284	315-0105-00		RES., FXD, CMPSN: 1M OHM, 5%, 0.25W	01121	CB1055
R2290	321-0327-00		RES., FXD, FILM: 24.9K OHM, 1%, 0.125W	91637	MFF1816G24901F
R2292	321-0308-00		RES., FXD, FILM: 15.8K OHM, 1%, 0.125W	91637	MFF1816G15801F
R2294	321-0343-00		RES., FXD, FILM: 36.5K OHM, 1%, 0.125W	91637	MFF1816G36501F
R2296	321-0343-00		RES., FXD, FILM: 36.5K OHM, 1%, 0.125W	91637	MFF1816G36501F
R2298	321-0308-00		RES., FXD, FILM: 15.8K OHM, 1%, 0.125W	91637	MFF1816G15801F
R2311	315-0470-00		RES., FXD, CMPSN: 47 OHM, 5%, 0.25W	01121	CB4705
R2312	315-0182-00		RES., FXD, CMPSN: 1.8K OHM, 5%, 0.25W	01121	CB1825
R2316	325-0263-00		RES., FXD, FILM: 10.0K OHM, 0.5%, 0.3W	07088	K747 10.0 K OHM
R2318	315-0512-00		RES., FXD, CMPSN: 5.1K OHM, 5%, 0.25W	01121	CB5125
R2320	325-0263-00		RES., FXD, FILM: 10.0K OHM, 0.5%, 0.3W	07088	K747 10.0 K OHM
R2321	315-0470-00		RES., FXD, CMPSN: 47 OHM, 5%, 0.25W	01121	CB4705
R2322	315-0470-00		RES., FXD, CMPSN: 47 OHM, 5%, 0.25W	01121	CB4705
R2326	315-0102-00		RES., FXD, CMPSN: 1K OHM, 5%, 0.25W	01121	CB1025
R2328	315-0750-00		RES., FXD, CMPSN: 75 OHM, 5%, 0.25W	01121	CB7505
R2330	315-0100-00		RES., FXD, CMPSN: 10 OHM, 5%, 0.25W	01121	CB1005
R2332	321-0228-09		RES., FXD, FILM: 2.32K OHM, 1%, 0.125W	91637	MFF1816C23200F
R2334	321-0289-09		RES., FXD, FILM: 10K OHM, 1%, 0.125W	91637	MFF1816C10001F
R2336	323-0264-00		RES., FXD, FILM: 5.49K OHM, 1%, 0.50W	91637	MFF1226G54900F
R2338	321-0263-09		RES., FXD, FILM: 5.36K OHM, 1%, 0.125W	24546	NE55E5361F
R2340	321-0963-07		RES., FXD, FILM: 98.73K OHM, 0.1%, 0.125W	91637	MFF1816C98731B
R2346	315-0102-00		RES., FXD, CMPSN: 1K OHM, 5%, 0.25W	01121	CB1025
R2348	315-0750-00		RES., FXD, CMPSN: 75 OHM, 5%, 0.25W	01121	CB7505
R2350	315-0100-00		RES., FXD, CMPSN: 10 OHM, 5%, 0.25W	01121	CB1005
R2352	311-1340-00		RES., VAR, NONWIR: 1K OHM, 10%, 0.50W	02111	43P102T672
R2354	315-0101-00		RES., FXD, CMPSN: 100 OHM, 5%, 0.25W	01121	CB1015
R2356	315-0101-00		RES., FXD, CMPSN: 100 OHM, 5%, 0.25W	01121	CB1015
R2366	315-0470-00		RES., FXD, CMPSN: 47 OHM, 5%, 0.25W	01121	CB4705
R2368	317-0682-00		RES., FXD, CMPSN: 6.8K OHM, 5%, 0.125W	01121	BB6825
R2370	315-0102-00		RES., FXD, CMPSN: 1K OHM, 5%, 0.25W	01121	CB1025

Replaceable Electrical Parts—7L18 Service

Ckt No.	Tektronix Part No.	Serial/Model No. Eff	Dscont	Name & Description	Mfr Code	Mfr Part Number
R2372	315-0271-00			RES., FXD, CMPSN: 270 OHM, 5%, 0.25W	01121	CB2715
R2374	317-0101-00			RES., FXD, CMPSN: 100 OHM, 5%, 0.125W	01121	BB1015
R2382	315-0471-00			RES., FXD, CMPSN: 470 OHM, 5%, 0.25W	01121	CB4715
R2384	317-0101-00			RES., FXD, CMPSN: 100 OHM, 5%, 0.125W	01121	BB1015
R2392	315-0151-00			RES., FXD, CMPSN: 150 OHM, 5%, 0.25W	01121	CB1515
R2394	317-0330-00			RES., FXD, CMPSN: 33 OHM, 5%, 0.125W	01121	BB3305
R2400	317-0510-00			RES., FXD, CMPSN: 51 OHM, 5%, 0.125W	01121	BB5105
R2402	321-0275-00			RES., FXD, FILM: 7.15K OHM, 1%, 0.125W	91637	MFF1816G71500F
R2404	315-0100-00			RES., FXD, CMPSN: 10 OHM, 5%, 0.25W	01121	CB1005
R2408	317-0510-00			RES., FXD, CMPSN: 51 OHM, 5%, 0.125W	01121	BB5105
R2410	321-0231-00			RES., FXD, FILM: 2.49K OHM, 1%, 0.125W	91637	MFF1816G24900F
R2412	315-0100-00			RES., FXD, CMPSN: 10 OHM, 5%, 0.25W	01121	CB1005
R2414	317-0221-00			RES., FXD, CMPSN: 220 OHM, 5%, 0.125W	01121	BB2215
R2418	317-0821-00			RES., FXD, CMPSN: 820 OHM, 5%, 0.125W	01121	BB8215
R2420	315-0181-00			RES., FXD, CMPSN: 180 OHM, 5%, 0.25W	01121	CB1815
R2422	315-0222-00			RES., FXD, CMPSN: 2.2K OHM, 5%, 0.25W	01121	CB2225
R2424	315-0821-00			RES., FXD, CMPSN: 820 OHM, 5%, 0.25W	01121	CB8215
R2426	315-0100-00			RES., FXD, CMPSN: 10 OHM, 5%, 0.25W	01121	CB1005
R2432	315-0221-00			RES., FXD, CMPSN: 220 OHM, 5%, 0.25W	01121	CB2215
R2436	315-0821-00			RES., FXD, CMPSN: 820 OHM, 5%, 0.25W	01121	CB8215
R2438	315-0222-00			RES., FXD, CMPSN: 2.2K OHM, 5%, 0.25W	01121	CB2225
R2440	303-0620-00			RES., FXD, CMPSN: 62 OHM, 5%, 1W	01121	CB6205
R2442	315-0821-00			RES., FXD, CMPSN: 820 OHM, 5%, 0.25W	01121	CB8215
R2444	307-0103-00			RES., FXD, CMPSN: 2.7 OHM, 5%, 0.25W	01121	CB27G5
R2460	317-0301-00			RES., FXD, CMPSN: 300 OHM, 5%, 0.125W	01121	BB3015
R2462	317-0510-00			RES., FXD, CMPSN: 51 OHM, 5%, 0.125W	01121	BB5105
R2464	317-0111-00	B010100	B020162	RES., FXD, CMPSN: 110 OHM, 5%, 0.125W	01121	BB1115
R2464	317-0360-00	B020163		RES., FXD, CMPSN: 36 OHM, 5%, 0.125W	01121	BB3605
R2465	317-0151-00	XB020163		RES., FXD, CMPSN: 150 OHM, 5%, 0.125W	01121	BB1515
R2466	317-0131-00	B010100	B020162X	RES., FXD, CMPSN: 130 OHM, 5%, 0.125W	01121	BB1315
R2467	317-0151-00			RES., FXD, CMPSN: 150 OHM, 5%, 0.125W	01121	BB1515
R2468	317-0180-00			RES., FXD, CMPSN: 18 OHM, 5%, 0.125W	01121	BB1805
R2470	317-0301-00			RES., FXD, CMPSN: 300 OHM, 5%, 0.125W	01121	BB3015
R2476	317-0301-00			RES., FXD, CMPSN: 300 OHM, 5%, 0.125W	01121	BB3015
R2478	317-0180-00			RES., FXD, CMPSN: 18 OHM, 5%, 0.125W	01121	BB1805
R2480	317-0301-00			RES., FXD, CMPSN: 300 OHM, 5%, 0.125W	01121	BB3015
R2486	315-0154-00			RES., FXD, CMPSN: 150K OHM, 5%, 0.25W	01121	CB1545
R2488	321-0193-00			RES., FXD, FILM: 1K OHM, 1%, 0.125W	91637	MFF1816G10000F
R2490	321-0260-00			RES., FXD, FILM: 4.99K OHM, 1%, 0.125W	91637	MFF1816G49900F
R2492	321-0335-00			RES., FXD, FILM: 30.1K OHM, 1%, 0.125W	91637	MFF1816G30101F
R2494	311-1269-00			RES., VAR, NONWIR: 20K OHM, 10%, 0.50W	32997	3329P-L58-203
R2496	321-0356-00			RES., FXD, FILM: 49.9K OHM, 1%, 0.125W	91637	MFF1816G49901F
R2500	321-0402-00			RES., FXD, FILM: 150K OHM, 1%, 0.125W	24546	NA55D1503F
R2502	321-0373-00			RES., FXD, FILM: 75K OHM, 1%, 0.125W	91637	MFF1816G75001F
R2504	321-0327-00			RES., FXD, FILM: 24.9K OHM, 1%, 0.125W	91637	MFF1816G24901F
R2506	321-0321-00			RES., FXD, FILM: 21.5K OHM, 1%, 0.125W	91637	MFF1816G21501F
R2508	321-0344-00			RES., FXD, FILM: 37.4K OHM, 1%, 0.125W	91637	MFF1816G37401F
R2510	321-0344-00			RES., FXD, FILM: 37.4K OHM, 1%, 0.125W	91637	MFF1816G37401F
R2512	321-0344-00			RES., FXD, FILM: 37.4K OHM, 1%, 0.125W	91637	MFF1816G37401F
R2514	321-0402-00			RES., FXD, FILM: 150K OHM, 1%, 0.125W	24546	NA55D1503F
R2516	321-0373-00			RES., FXD, FILM: 75K OHM, 1%, 0.125W	91637	MFF1816G75001F
R2518	321-0356-00			RES., FXD, FILM: 49.9K OHM, 1%, 0.125W	91637	MFF1816G49901F
R2520	321-0327-00			RES., FXD, FILM: 24.9K OHM, 1%, 0.125W	91637	MFF1816G24901F
R2522	321-0321-00			RES., FXD, FILM: 21.5K OHM, 1%, 0.125W	91637	MFF1816G21501F
R2524	321-0344-00			RES., FXD, FILM: 37.4K OHM, 1%, 0.125W	91637	MFF1816G37401F
R2526	321-0344-00			RES., FXD, FILM: 37.4K OHM, 1%, 0.125W	91637	MFF1816G37401F
R2528	321-0344-00			RES., FXD, FILM: 37.4K OHM, 1%, 0.125W	91637	MFF1816G37401F

Replaceable Electrical Parts—7L18 Service

Ckt No.	Tektronix Part No.	Serial/Model No. Eff	Dscont	Name & Description	Mfr Code	Mfr Part Number
R2530	321-0402-00			RES.,FXD,FILM:150K OHM,1%,0.125W	24546	NA55D1503F
R2532	321-0356-00			RES.,FXD,FILM:49.9K OHM,1%,0.125W	91637	MFF1816G49901F
R2534	321-0356-00			RES.,FXD,FILM:49.9K OHM,1%,0.125W	91637	MFF1816G49901F
R2536	321-0373-00			RES.,FXD,FILM:75K OHM,1%,0.125W	91637	MFF1816G75001F
R2538	321-0335-00			RES.,FXD,FILM:30.1K OHM,1%,0.125W	91637	MFF1816G30101F
R2540	321-0402-00			RES.,FXD,FILM:150K OHM,1%,0.125W	24546	NA55D1503F
R2542	321-0335-00			RES.,FXD,FILM:30.1K OHM,1%,0.125W	91637	MFF1816G30101F
R2552	311-1268-00			RES.,VAR, NONWIR:10K OHM,10%,0.50W	32997	3329P-L58-103
R2554	315-0103-00			RES.,FXD,CMPSN:10K OHM,5%,0.25W	01121	CB1035
R2556	311-1268-00			RES.,VAR, NONWIR:10K OHM,10%,0.50W	32997	3329P-L58-103
R2558	315-0103-00			RES.,FXD,CMPSN:10K OHM,5%,0.25W	01121	CB1035
R2560	311-1268-00			RES.,VAR, NONWIR:10K OHM,10%,0.50W	32997	3329P-L58-103
R2562	315-0103-00			RES.,FXD,CMPSN:10K OHM,5%,0.25W	01121	CB1035
R2564	311-1268-00			RES.,VAR, NONWIR:10K OHM,10%,0.50W	32997	3329P-L58-103
R2566	315-0103-00			RES.,FXD,CMPSN:10K OHM,5%,0.25W	01121	CB1035
R2568	311-1268-00			RES.,VAR, NONWIR:10K OHM,10%,0.50W	32997	3329P-L58-103
R2570	315-0103-00			RES.,FXD,CMPSN:10K OHM,5%,0.25W	01121	CB1035
R2572	315-0104-00			RES.,FXD,CMPSN:100K OHM,5%,0.25W	01121	CB1045
R2574	311-1268-00			RES.,VAR, NONWIR:10K OHM,10%,0.50W	32997	3329P-L58-103
R2575	321-0385-00			RES.,FXD,FILM:100K OHM,1%,0.125W	91637	MFF1816G10002F
R2576	311-1268-00			RES.,VAR, NONWIR:10K OHM,10%,0.50W	32997	3329P-L58-103
R2577	315-0103-00			RES.,FXD,CMPSN:10K OHM,5%,0.25W	01121	CB1035
R2578	311-1268-00			RES.,VAR, NONWIR:10K OHM,10%,0.50W	32997	3329P-L58-103
R2579	315-0104-00			RES.,FXD,CMPSN:100K OHM,5%,0.25W	01121	CB1045
R2580	311-1268-00			RES.,VAR, NONWIR:10K OHM,10%,0.50W	32997	3329P-L58-103
R2581	315-0274-00			RES.,FXD,CMPSN:270K OHM,5%,0.25W	01121	CB2745
R2582	311-1268-00			RES.,VAR, NONWIR:10K OHM,10%,0.50W	32997	3329P-L58-103
R2583	315-0563-00			RES.,FXD,CMPSN:56K OHM,5%,0.25W	01121	CB5635
R2584	311-1268-00			RES.,VAR, NONWIR:10K OHM,10%,0.50W	32997	3329P-L58-103
R2585	311-1274-00			RES.,VAR, NONWIR:500K OHM,10%,0.50W	32997	3329P-L58-504
R2586	321-0318-00			RES.,FXD,FILM:20K OHM,1%,0.125W	91637	MFF1816G20001F
R2587	315-0105-00			RES.,FXD,CMPSN:1M OHM,5%,0.25W	01121	CB1055
R2588	321-0312-00			RES.,FXD,FILM:17.4K OHM,1%,0.125W	91637	MFF1816G17401F
R2589	311-1267-00			RES.,VAR, NONWIR:5K OHM,10%,0.50W	32997	3329P-L58-502
R2590	321-0312-00			RES.,FXD,FILM:17.4K OHM,1%,0.125W	91637	MFF1816G17401F
R2591	315-0470-00			RES.,FXD,CMPSN:47 OHM,5%,0.25W	01121	CB4705
R2592	321-0312-00			RES.,FXD,FILM:17.4K OHM,1%,0.125W	91637	MFF1816G17401F
R2594	321-0312-00			RES.,FXD,FILM:17.4K OHM,1%,0.125W	91637	MFF1816G17401F
R2596	321-0312-00			RES.,FXD,FILM:17.4K OHM,1%,0.125W	91637	MFF1816G17401F
R2598	321-0312-00			RES.,FXD,FILM:17.4K OHM,1%,0.125W	91637	MFF1816G17401F
R2600	315-0470-00			RES.,FXD,CMPSN:47 OHM,5%,0.25W	01121	CB4705
R2602	321-0348-00			RES.,FXD,FILM:41.2K OHM,1%,0.125W	91637	MFF1816G41201F
R2603	315-0470-00			RES.,FXD,CMPSN:47 OHM,5%,0.25W	01121	CB4705
R2620	315-0103-00			RES.,FXD,CMPSN:10K OHM,5%,0.25W	01121	CB1035
R2622	315-0302-00			RES.,FXD,CMPSN:3K OHM,5%,0.25W	01121	CB3025
R2624	315-0302-00			RES.,FXD,CMPSN:3K OHM,5%,0.25W	01121	CB3025
R2626	315-0302-00			RES.,FXD,CMPSN:3K OHM,5%,0.25W	01121	CB3025
R2628	311-0771-00			RES.,VAR, NONWIR:PNL,1K OHM,0.5W/SW	12697	381-CM39686
R2630	315-0302-00			RES.,FXD,CMPSN:3K OHM,5%,0.25W	01121	CB3025
R2638	311-1298-00			RES.,VAR, NONWIR:10K OHM,20%,0.50W	01121	W-7909
R2642	317-0201-00			RES.,FXD,CMPSN:200 OHM,5%,0.125W	01121	BB2015
R2644	317-0201-00			RES.,FXD,CMPSN:200 OHM,5%,0.125W	01121	BB2015
R2646	317-0201-00			RES.,FXD,CMPSN:200 OHM,5%,0.125W	01121	BB2015
R2648	317-0201-00			RES.,FXD,CMPSN:200 OHM,5%,0.125W	01121	BB2015
R2650	317-0201-00			RES.,FXD,CMPSN:200 OHM,5%,0.125W	01121	BB2015
R2652	317-0201-00			RES.,FXD,CMPSN:200 OHM,5%,0.125W	01121	BB2015
R2654	317-0201-00			RES.,FXD,CMPSN:200 OHM,5%,0.125W	01121	BB2015

Replaceable Electrical Parts—7L18 Service

Ckt No.	Tektronix Part No.	Serial/Model No. Eff	Dscont	Name & Description	Mfr Code	Mfr Part Number
R2656	317-0101-00			RES.,FXD,CMPSN:100 OHM,5%,0.125W	01121	BB1015
R2660	317-0100-00			RES.,FXD,CMPSN:10 OHM,5%,0.125W	01121	BB1005
R2662	317-0100-00			RES.,FXD,CMPSN:10 OHM,5%,0.125W	01121	BB1005
R2692	317-0122-00			RES.,FXD,CMPSN:1.2K OHM,5%,0.125W	01121	BB1225
R2696	317-0182-00			RES.,FXD,CMPSN:1.8K OHM,5%,0.125W	01121	BB1825
R2699	317-0330-00			RES.,FXD,CMPSN:33 OHM,5%,0.125W	01121	BB3305
R2700	315-0151-00			RES.,FXD,CMPSN:150 OHM,5%,0.25W	01121	CB1515
R2701	317-0153-00			RES.,FXD,CMPSN:15K OHM,5%,0.125W	01121	BB1535
R2702	317-0100-00			RES.,FXD,CMPSN:10 OHM,5%,0.125W	01121	BB1005
R2704	317-0102-00			RES.,FXD,CMPSN:1K OHM,5%,0.125W	01121	BB1025
R2706	317-0103-00			RES.,FXD,CMPSN:10K OHM,5%,0.125W	01121	BB1035
R2708	317-0432-00			RES.,FXD,CMPSN:4.3K OHM,5%,0.125W	01121	BB4325
R2714	317-0222-00			RES.,FXD,CMPSN:2.2K OHM,5%,0.125W	01121	BB2225
R2716	317-0182-00			RES.,FXD,CMPSN:1.8K OHM,5%,0.125W	01121	BB1825
R2717	317-0153-00			RES.,FXD,CMPSN:15K OHM,5%,0.125W	01121	BB1535
R2718	317-0151-00			RES.,FXD,CMPSN:150 OHM,5%,0.125W	01121	BB1515
R2724	315-0151-00			RES.,FXD,CMPSN:150 OHM,5%,0.25W	01121	CB1515
R2726	317-0222-00			RES.,FXD,CMPSN:2.2K OHM,5%,0.125W	01121	BB2225
R2731	317-0153-00			RES.,FXD,CMPSN:15K OHM,5%,0.125W	01121	BB1535
R2732	317-0182-00			RES.,FXD,CMPSN:1.8K OHM,5%,0.125W	01121	BB1825
R2734	317-0222-00			RES.,FXD,CMPSN:2.2K OHM,5%,0.125W	01121	BB2225
R2740	317-0432-00			RES.,FXD,CMPSN:4.3K OHM,5%,0.125W	01121	BB4325
R2742	317-0103-00			RES.,FXD,CMPSN:10K OHM,5%,0.125W	01121	BB1035
R2744	317-0102-00			RES.,FXD,CMPSN:1K OHM,5%,0.125W	01121	BB1025
R2746	317-0510-00			RES.,FXD,CMPSN:51 OHM,5%,0.125W	01121	BB5105
R2748	321-0275-00			RES.,FXD,FILM:7.15K OHM,1%,0.125W	91637	MFF1816G71500F
R2750	317-0100-00			RES.,FXD,CMPSN:10 OHM,5%,0.125W	01121	BB1005
R2754	317-0510-00			RES.,FXD,CMPSN:51 OHM,5%,0.125W	01121	BB5105
R2756	321-0261-00			RES.,FXD,FILM:5.11K OHM,1%,0.125W	91637	MFF1816G51100F
R2758	317-0100-00			RES.,FXD,CMPSN:10 OHM,5%,0.125W	01121	BB1005
R2760	317-0122-00			RES.,FXD,CMPSN:1.2K OHM,5%,0.125W	01121	BB1225
R2762	317-0182-00			RES.,FXD,CMPSN:1.8K OHM,5%,0.125W	01121	BB1825
R2764	317-0432-00			RES.,FXD,CMPSN:4.3K OHM,5%,0.125W	01121	BB4325
R2766	317-0222-00			RES.,FXD,CMPSN:2.2K OHM,5%,0.125W	01121	BB2225
R2768	317-0100-00			RES.,FXD,CMPSN:10 OHM,5%,0.125W	01121	BB1005
R2770	315-0151-00			RES.,FXD,CMPSN:150 OHM,5%,0.25W	01121	CB1515
R2774	321-0275-00			RES.,FXD,FILM:7.15K OHM,1%,0.125W	91637	MFF1816G71500F
R2776	317-0100-00			RES.,FXD,CMPSN:10 OHM,5%,0.125W	01121	BB1005
R2778	317-0510-00			RES.,FXD,CMPSN:51 OHM,5%,0.125W	01121	BB5105
R2782	317-0510-00			RES.,FXD,CMPSN:51 OHM,5%,0.125W	01121	BB5105
R2784	321-0261-00			RES.,FXD,FILM:5.11K OHM,1%,0.125W	91637	MFF1816G51100F
R2786	317-0100-00			RES.,FXD,CMPSN:10 OHM,5%,0.125W	01121	BB1005
R2788	317-0122-00			RES.,FXD,CMPSN:1.2K OHM,5%,0.125W	01121	BB1225
R2790	317-0182-00			RES.,FXD,CMPSN:1.8K OHM,5%,0.125W	01121	BB1825
R2792	317-0432-00			RES.,FXD,CMPSN:4.3K OHM,5%,0.125W	01121	BB4325
R2794	317-0222-00			RES.,FXD,CMPSN:2.2K OHM,5%,0.125W	01121	BB2225
R2796	317-0100-00			RES.,FXD,CMPSN:10 OHM,5%,0.125W	01121	BB1005
R2798	315-0151-00			RES.,FXD,CMPSN:150 OHM,5%,0.25W	01121	CB1515
R2804	321-0289-00			RES.,FXD,FILM:10K OHM,1%,0.125W	91637	MFF1816G10001F
R2806	321-0276-00			RES.,FXD,FILM:7.32K OHM,1%,0.125W	91637	MFF1816G73200F
R2808	315-0470-00			RES.,FXD,CMPSN:47 OHM,5%,0.25W	01121	CB4705
R2810	321-0388-00			RES.,FXD,FILM:107K OHM,1%,0.125W	91637	MFF1816G10702F
R2812	315-0471-00			RES.,FXD,CMPSN:470 OHM,5%,0.25W	01121	CB4715
R2827	315-0331-00			RES.,FXD,CMPSN:330 OHM,5%,0.25W	01121	CB3315
R2828	315-0222-00			RES.,FXD,CMPSN:2.2K OHM,5%,0.25W	01121	CB2225
R2831	315-0331-00			RES.,FXD,CMPSN:330 OHM,5%,0.25W	01121	CB3315
R2832	315-0681-00			RES.,FXD,CMPSN:680 OHM,5%,0.25W	01121	CB6815

Replaceable Electrical Parts—7L18 Service

Ckt No.	Tektronix Part No.	Serial/Model No. Eff	Dscont	Name & Description	Mfr Code	Mfr Part Number
R2833	321-0289-00			RES.,FXD,FILM:10K OHM,1%,0.125W	91637	MFF1816G10001F
R2834	321-0356-00			RES.,FXD,FILM:49.9K OHM,1%,0.125W	91637	MFF1816G49901F
R2835	317-0510-00	XB020600		RES.,FXD,CMPSN:51 OHM,5%,0.125W	01121	BB5105
R2836	321-0356-00			RES.,FXD,FILM:49.9K OHM,1%,0.125W	91637	MFF1816G49901F
R2860	315-0510-00			RES.,FXD,CMPSN:51 OHM,5%,0.25W	01121	CB5105
R2862	315-0510-00			RES.,FXD,CMPSN:51 OHM,5%,0.25W	01121	CB5105
R2870	315-0102-00	XB020625		RES.,FXD,CMPSN:1K OHM,5%,0.25W	01121	CB1025
R2880	315-0102-00			RES.,FXD,CMPSN:1K OHM,5%,0.25W	01121	CB1025
R2896	321-0509-00	B010100	B010159	RES.,FXD,FILM:1.96M OHM,1%,0.125W	91637	MFF1813G19603F
R2896	315-0205-00	B010160	B020533	RES.,FXD,CMPSN:2M OHM,5%,0.25W	01121	CB2055
R2896	321-0436-00	B020534		RES.,FXD,FILM:340K OHM,1%,0.125W	91637	MFF1816G34002F
R2900	-----			(FURNISHED AS A UNIT WITH 672-0589-00)		
R3000	315-0182-00			RES.,FXD,CMPSN:1.8K OHM,5%,0.25W	01121	CB1825
R3002	315-0301-00			RES.,FXD,CMPSN:300 OHM,5%,0.25W	01121	CB3015
R3004	321-0277-00			RES.,FXD,FILM:7.5K OHM,1%,0.125W	91637	MFF1816G75000F
R3006	315-0620-00			RES.,FXD,CMPSN:62 OHM,5%,0.25W	01121	CB6205
R3008	315-0220-00			RES.,FXD,CMPSN:22 OHM,5%,0.25W	01121	CB2205
R3010	315-0222-00			RES.,FXD,CMPSN:2.2K OHM,5%,0.25W	01121	CB2225
R3011	315-0222-00			RES.,FXD,CMPSN:2.2K OHM,5%,0.25W	01121	CB2225
R3014	315-0220-00			RES.,FXD,CMPSN:22 OHM,5%,0.25W	01121	CB2205
R3016	315-0620-00			RES.,FXD,CMPSN:62 OHM,5%,0.25W	01121	CB6205
R3018	315-0301-00			RES.,FXD,CMPSN:300 OHM,5%,0.25W	01121	CB3015
R3020	315-0222-00			RES.,FXD,CMPSN:2.2K OHM,5%,0.25W	01121	CB2225
R3022	315-0301-00			RES.,FXD,CMPSN:300 OHM,5%,0.25W	01121	CB3015
R3024	315-0152-00			RES.,FXD,CMPSN:1.5K OHM,5%,0.25W	01121	CB1525
R3026	315-0152-00			RES.,FXD,CMPSN:1.5K OHM,5%,0.25W	01121	CB1525
R3028	315-0222-00			RES.,FXD,CMPSN:2.2K OHM,5%,0.25W	01121	CB2225
R3040	321-0177-00			RES.,FXD,FILM:681 OHM,1%,0.125W	91637	MFF1816G681ROF
R3042	321-0143-00			RES.,FXD,FILM:301 OHM,1%,0.125W	91637	MFF1816G301ROF
R3044	315-0331-00			RES.,FXD,CMPSN:330 OHM,5%,0.25W	01121	CB3315
R3046	315-0220-00			RES.,FXD,CMPSN:22 OHM,5%,0.25W	01121	CB2205
R3048	315-0100-00			RES.,FXD,CMPSN:10 OHM,5%,0.25W	01121	CB1005
R3050	315-0220-00			RES.,FXD,CMPSN:22 OHM,5%,0.25W	01121	CB2205
R3052	315-0100-00			RES.,FXD,CMPSN:10 OHM,5%,0.25W	01121	CB1005
R3054	321-0202-00			RES.,FXD,FILM:1.24K OHM,1%,0.125W	91637	MFF1816G12400F
R3056	321-0158-00			RES.,FXD,FILM:432 OHM,1%,0.125W	91637	MFF1816G432ROF
R3058	315-0391-00			RES.,FXD,CMPSN:390 OHM,5%,0.25W	01121	CB3915
R3060	311-1259-00			RES.,VAR,NONWIR:100 OHM,10%,0.50W	32997	3329P-L58-101
R3062	315-0222-00			RES.,FXD,CMPSN:2.2K OHM,5%,0.25W	01121	CB2225
R3064	315-0472-00			RES.,FXD,CMPSN:4.7K OHM,5%,0.25W	01121	CB4725
R3066	315-0390-00			RES.,FXD,CMPSN:39 OHM,5%,0.25W	01121	CB3905
R3068	315-0223-00			RES.,FXD,CMPSN:22K OHM,5%,0.25W	01121	CB2235
R3070	315-0202-00			RES.,FXD,CMPSN:2K OHM,5%,0.25W	01121	CB2025
R3072	315-0102-00			RES.,FXD,CMPSN:1K OHM,5%,0.25W	01121	CB1025
R3074	315-0122-00			RES.,FXD,CMPSN:1.2K OHM,5%,0.25W	01121	CB1225
R3076	315-0682-00			RES.,FXD,CMPSN:6.8K OHM,5%,0.25W	01121	CB6825
R3078	315-0103-00			RES.,FXD,CMPSN:10K OHM,5%,0.25W	01121	CB1035
R3080	315-0105-00			RES.,FXD,CMPSN:1M OHM,5%,0.25W	01121	CB1055
R3082	315-0105-00			RES.,FXD,CMPSN:1M OHM,5%,0.25W	01121	CB1055
R3084	321-0072-00			RES.,FXD,FILM:54.9 OHM,1%,0.125W	91637	MFF1816G54901F
R3086	321-0177-00			RES.,FXD,FILM:681 OHM,1%,0.125W	91637	MFF1816G681ROF
R3088	321-0143-00			RES.,FXD,FILM:301 OHM,1%,0.125W	91637	MFF1816G301ROF
R3090	315-0220-00			RES.,FXD,CMPSN:22 OHM,5%,0.25W	01121	CB2205
R3092	321-0277-00			RES.,FXD,FILM:7.5K OHM,1%,0.125W	91637	MFF1816G75000F
R3094	315-0100-00			RES.,FXD,CMPSN:10 OHM,5%,0.25W	01121	CB1005
R3096	321-0202-00			RES.,FXD,FILM:1.24K OHM,1%,0.125W	91637	MFF1816G12400F
R3098	321-0158-00			RES.,FXD,FILM:432 OHM,1%,0.125W	91637	MFF1816G432ROF

Ckt No.	Tektronix Part No.	Serial/Model No. Eff	Dscont	Name & Description	Mfr Code	Mfr Part Number
R3100	321-0072-00			RES., FXD, FILM: 54.9 OHM, 1%, 0.125W	91637	MFF1816G54R90F
R3102	315-0161-00			RES., FXD, CMPSN: 160 OHM, 5%, 0.25W	01121	CB1615
R3104	315-0220-00			RES., FXD, CMPSN: 22 OHM, 5%, 0.25W	01121	CB2205
R3106	315-0431-00			RES., FXD, CMPSN: 430 OHM, 5%, 0.25W	01121	CB4315
R3108	315-0100-00			RES., FXD, CMPSN: 10 OHM, 5%, 0.25W	01121	CB1005
R3110	315-0391-00			RES., FXD, CMPSN: 390 OHM, 5%, 0.25W	01121	CB3915
R3112	315-0680-00			RES., FXD, CMPSN: 68 OHM, 5%, 0.25W	01121	CB6805
R3115	311-1260-00			RES., VAR, NONWIR: 250 OHM, 10%, 0.50W	32997	3329P-L58-251
R3130	321-0131-00			RES., FXD, FILM: 226 OHM, 1%, 0.125W	91637	MFF1816G226R0F
R3132	307-0106-00			RES., FXD, CMPSN: 4.7 OHM, 5%, 0.25W	01121	CB47G5
R3134	303-0561-00			RES., FXD, CMPSN: 560 OHM, 5%, 1W	01121	GB5615
R3136	307-0106-00			RES., FXD, CMPSN: 4.7 OHM, 5%, 0.25W	01121	CB47G5
R3138	303-0561-00			RES., FXD, CMPSN: 560 OHM, 5%, 1W	01121	GB5615
R3140	321-0077-00			RES., FXD, FILM: 61.9 OHM, 1%, 0.125W	91637	MFF1816G61R90F
R3142	321-0155-00			RES., FXD, FILM: 402 OHM, 1%, 0.125W	91637	MFF1816G402R0F
R3144	321-0108-00			RES., FXD, FILM: 130 OHM, 1%, 0.125W	91637	MFF1816G130R0F
R3146	321-0164-00			RES., FXD, FILM: 499 OHM, 1%, 0.125W	91637	MFF1816G499R0F
R3150	321-0155-00			RES., FXD, FILM: 402 OHM, 1%, 0.125W	91637	MFF1816G402R0F
R3154	321-0155-00			RES., FXD, FILM: 402 OHM, 1%, 0.125W	91637	MFF1816G402R0F
R3158	321-0155-00			RES., FXD, FILM: 402 OHM, 1%, 0.125W	91637	MFF1816G402R0F
R3160	315-0104-00			RES., FXD, CMPSN: 100K OHM, 5%, 0.25W	01121	CB1045
R3164	315-0102-00			RES., FXD, CMPSN: 1K OHM, 5%, 0.25W	01121	CB1025
R3165	311-1259-00			RES., VAR, NONWIR: 100 OHM, 10%, 0.50W	32997	3329P-L58-101
R3166	315-0102-00			RES., FXD, CMPSN: 1K OHM, 5%, 0.25W	01121	CB1025
R3172	321-0155-00			RES., FXD, FILM: 402 OHM, 1%, 0.125W	91637	MFF1816G402R0F
R3174	321-0155-00			RES., FXD, FILM: 402 OHM, 1%, 0.125W	91637	MFF1816G402R0F
R3176	321-0155-00			RES., FXD, FILM: 402 OHM, 1%, 0.125W	91637	MFF1816G402R0F
R3210	311-1259-00			RES., VAR, NONWIR: 100 OHM, 10%, 0.50W	32997	3329P-L58-101
R3212	321-0097-00			RES., FXD, FILM: 100 OHM, 1%, 0.125W	91637	MFF1816G100R0F
R3213	321-0155-00			RES., FXD, FILM: 402 OHM, 1%, 0.125W	91637	MFF1816G402R0F
R3214	321-0037-00			RES., FXD, FILM: 23.7 OHM, 1%, 0.125W	91637	MFF1816G23R70F
R3215	311-1259-00			RES., VAR, NONWIR: 100 OHM, 10%, 0.50W	32997	3329P-L58-101
R3216	321-0097-00			RES., FXD, FILM: 100 OHM, 1%, 0.125W	91637	MFF1816G100R0F
R3220	321-0017-00			RES., FXD, FILM: 14.7 OHM, 1%, 0.125W	91637	MFF1816G14R70F
R3222	321-0097-00			RES., FXD, FILM: 100 OHM, 1%, 0.125W	91637	MFF1816G100R0F
R3224	321-0037-00			RES., FXD, FILM: 23.7 OHM, 1%, 0.125W	91637	MFF1816G23R70F
R3225	311-1259-00			RES., VAR, NONWIR: 100 OHM, 10%, 0.50W	32997	3329P-L58-101
R3226	321-0155-00			RES., FXD, FILM: 402 OHM, 1%, 0.125W	91637	MFF1816G402R0F
R3228	321-0155-00			RES., FXD, FILM: 402 OHM, 1%, 0.125W	91637	MFF1816G402R0F
R3230	311-1259-00			RES., VAR, NONWIR: 100 OHM, 10%, 0.50W	32997	3329P-L58-101
R3232	321-0097-00			RES., FXD, FILM: 100 OHM, 1%, 0.125W	91637	MFF1816G100R0F
R3235	311-1259-00			RES., VAR, NONWIR: 100 OHM, 10%, 0.50W	32997	3329P-L58-101
R3236	321-0092-00			RES., FXD, FILM: 88.7 OHM, 1%, 0.125W	91637	MFF1816G88R70F
R3238	321-0037-00			RES., FXD, FILM: 23.7 OHM, 1%, 0.125W	91637	MFF1816G23R70F
R3240	321-0155-00			RES., FXD, FILM: 402 OHM, 1%, 0.125W	91637	MFF1816G402R0F
R3242	321-0105-00			RES., FXD, FILM: 121 OHM, 1%, 0.125W	91637	MFF1816G121R0F
R3244	321-0155-00			RES., FXD, FILM: 402 OHM, 1%, 0.125W	91637	MFF1816G402R0F
R3245	311-1259-00			RES., VAR, NONWIR: 100 OHM, 10%, 0.50W	32997	3329P-L58-101
R3246	321-0092-00			RES., FXD, FILM: 88.7 OHM, 1%, 0.125W	91637	MFF1816G88R70F
R3248	321-0105-00			RES., FXD, FILM: 121 OHM, 1%, 0.125W	91637	MFF1816G121R0F
R3250	321-0155-00			RES., FXD, FILM: 402 OHM, 1%, 0.125W	91637	MFF1816G402R0F
R3260	315-0182-00			RES., FXD, CMPSN: 1.8K OHM, 5%, 0.25W	01121	CB1825
R3262	315-0151-00			RES., FXD, CMPSN: 150 OHM, 5%, 0.25W	01121	CB1515
R3264	321-0039-00			RES., FXD, FILM: 24.9 OHM, 1%, 0.125W	91637	MFF1816G24R90F
R3265	311-1260-00			RES., VAR, NONWIR: 250 OHM, 10%, 0.50W	32997	3329P-L58-251
R3266	321-0164-00			RES., FXD, FILM: 499 OHM, 1%, 0.125W	91637	MFF1816G499R0F
R3270	315-0162-00			RES., FXD, CMPSN: 1.6K OHM, 5%, 0.25W	01121	CB1625

Replaceable Electrical Parts—7L18 Service

Ckt No.	Tektronix Part No.	Serial/Model No. Eff Dscont	Name & Description	Mfr Code	Mfr Part Number
R3272	315-0301-00		RES., FXD, CMPSN: 300 OHM, 5%, 0.25W	01121	CB3015
R3274	315-0103-00		RES., FXD, CMPSN: 10K OHM, 5%, 0.25W	01121	CB1035
R3276	315-0621-00		RES., FXD, CMPSN: 620 OHM, 5%, 0.25W	01121	CB6215
R3278	315-0821-00		RES., FXD, CMPSN: 820 OHM, 5%, 0.25W	01121	CB8215
R3280	315-0471-00		RES., FXD, CMPSN: 470 OHM, 5%, 0.25W	01121	CB4715
R3282	315-0102-00		RES., FXD, CMPSN: 1K OHM, 5%, 0.25W	01121	CB1025
R3284	315-0222-00		RES., FXD, CMPSN: 2.2K OHM, 5%, 0.25W	01121	CB2225
R3286	315-0201-00		RES., FXD, CMPSN: 200 OHM, 5%, 0.25W	01121	CB2015
R3310	315-0101-00		RES., FXD, CMPSN: 100 OHM, 5%, 0.25W	01121	CB1015
R3314	315-0101-00		RES., FXD, CMPSN: 100 OHM, 5%, 0.25W	01121	CB1015
R3318	315-0101-00		RES., FXD, CMPSN: 100 OHM, 5%, 0.25W	01121	CB1015
R3320	315-0101-00		RES., FXD, CMPSN: 100 OHM, 5%, 0.25W	01121	CB1015
R3324	315-0101-00		RES., FXD, CMPSN: 100 OHM, 5%, 0.25W	01121	CB1015
R3328	315-0101-00		RES., FXD, CMPSN: 100 OHM, 5%, 0.25W	01121	CB1015
R3330	315-0101-00		RES., FXD, CMPSN: 100 OHM, 5%, 0.25W	01121	CB1015
R3334	315-0101-00		RES., FXD, CMPSN: 100 OHM, 5%, 0.25W	01121	CB1015
R3338	315-0101-00		RES., FXD, CMPSN: 100 OHM, 5%, 0.25W	01121	CB1015
R3340	315-0101-00		RES., FXD, CMPSN: 100 OHM, 5%, 0.25W	01121	CB1015
R3344	315-0101-00		RES., FXD, CMPSN: 100 OHM, 5%, 0.25W	01121	CB1015
R3346	315-0332-00		RES., FXD, CMPSN: 3.3K OHM, 5%, 0.25W	01121	CB3325
R3348	315-0101-00		RES., FXD, CMPSN: 100 OHM, 5%, 0.25W	01121	CB1015
R3350	315-0102-00		RES., FXD, CMPSN: 1K OHM, 5%, 0.25W	01121	CB1025
R3352	315-0102-00		RES., FXD, CMPSN: 1K OHM, 5%, 0.25W	01121	CB1025
R3353	315-0332-00		RES., FXD, CMPSN: 3.3K OHM, 5%, 0.25W	01121	CB3325
R3356	315-0332-00		RES., FXD, CMPSN: 3.3K OHM, 5%, 0.25W	01121	CB3325
R3358	315-0102-00		RES., FXD, CMPSN: 1K OHM, 5%, 0.25W	01121	CB1025
R3364	315-0332-00		RES., FXD, CMPSN: 3.3K OHM, 5%, 0.25W	01121	CB3325
R3366	315-0332-00		RES., FXD, CMPSN: 3.3K OHM, 5%, 0.25W	01121	CB3325
R3368	315-0332-00		RES., FXD, CMPSN: 3.3K OHM, 5%, 0.25W	01121	CB3325
R3370	315-0332-00		RES., FXD, CMPSN: 3.3K OHM, 5%, 0.25W	01121	CB3325
R3372	315-0332-00		RES., FXD, CMPSN: 3.3K OHM, 5%, 0.25W	01121	CB3325
R3374	315-0332-00		RES., FXD, CMPSN: 3.3K OHM, 5%, 0.25W	01121	CB3325
R3376	315-0332-00		RES., FXD, CMPSN: 3.3K OHM, 5%, 0.25W	01121	CB3325
R3420	315-0151-00		RES., FXD, CMPSN: 150 OHM, 5%, 0.25W	01121	CB1515
R3426	315-0270-00		RES., FXD, CMPSN: 27 OHM, 5%, 0.25W	01121	CB2705
R3430	315-0223-00		RES., FXD, CMPSN: 22K OHM, 5%, 0.25W	01121	CB2235
R3432	315-0101-00		RES., FXD, CMPSN: 100 OHM, 5%, 0.25W	01121	CB1015
R3434	315-0270-00		RES., FXD, CMPSN: 27 OHM, 5%, 0.25W	01121	CB2705
R3435	315-0102-00		RES., FXD, CMPSN: 1K OHM, 5%, 0.25W	01121	CB1025
R3436	301-0271-00		RES., FXD, CMPSN: 270 OHM, 5%, 0.50W	01121	EB2715
R3440	315-0202-00		RES., FXD, CMPSN: 2K OHM, 5%, 0.25W	01121	CB2025
R3442	315-0102-00		RES., FXD, CMPSN: 1K OHM, 5%, 0.25W	01121	CB1025
R3444	315-0333-00		RES., FXD, CMPSN: 33K OHM, 5%, 0.25W	01121	CB3335
R3448	315-0301-00		RES., FXD, CMPSN: 300 OHM, 5%, 0.25W	01121	CB3015
R3449	315-0180-00		RES., FXD, CMPSN: 18 OHM, 5%, 0.25W	01121	CB1805
R3450	301-0101-00		RES., FXD, CMPSN: 100 OHM, 5%, 0.50W	01121	EB1015
R3451	315-0681-00		RES., FXD, CMPSN: 680 OHM, 5%, 0.25W	01121	CB6815
R3454	315-0301-00		RES., FXD, CMPSN: 300 OHM, 5%, 0.25W	01121	CB3015
R3456	307-0105-00		RES., FXD, CMPSN: 3.9 OHM, 5%, 0.25W	01121	CB39G5
R3458	315-0560-00		RES., FXD, CMPSN: 56 OHM, 5%, 0.25W	01121	CB5605
R3460	303-0331-00		RES., FXD, CMPSN: 330 OHM, 5%, 1W	01121	GB3315
R3480	321-0264-00		RES., FXD, FILM: 5.49K OHM, 1%, 0.125W	91637	MFF1816G54900F
R3482	315-0203-00		RES., FXD, CMPSN: 20K OHM, 5%, 0.25W	01121	CB2035
R3484	315-0103-00		RES., FXD, CMPSN: 10K OHM, 5%, 0.25W	01121	CB1035
R3486	308-0441-00		RES., FXD, WW: 3 OHM, 5%, 3W	91637	CW2B-3R00J
R3488	308-0441-00		RES., FXD, WW: 3 OHM, 5%, 3W	91637	CW2B-3R00J
R3490	315-0331-00		RES., FXD, CMPSN: 330 OHM, 5%, 0.25W	01121	CB3315

Ckt No.	Tektronix Part No.	Serial/Model No. Eff	Dscont	Name & Description	Mfr Code	Mfr Part Number
R3492	315-0103-00			RES., FXD, CMPSN:10K OHM, 5%, 0.25W	01121	CB1035
R3494	321-0310-00			RES., FXD, FILM:16.5K OHM, 1%, 0.125W	91637	MFF1816G16501F
R3496	321-0093-00			RES., FXD, FILM:90.9 OHM, 1%, 0.125W	91637	MFF1816G90R90F
R3498	315-0102-00			RES., FXD, CMPSN:1K OHM, 5%, 0.25W	01121	CB1025
R3499	308-0441-00			RES., FXD, WW:3 OHM, 5%, 3W	91637	CW2B-3R00J
R3500	315-0222-00			RES., FXD, CMPSN:2.2K OHM, 5%, 0.25W	01121	CB2225
R3501	321-0231-00			RES., FXD, FILM:2.49K OHM, 1%, 0.125W	91637	MFF1816G24900F
R3502	321-0256-00			RES., FXD, FILM:4.53K OHM, 1%, 0.125W	91637	MFF1816G45300F
R3503	321-0277-00			RES., FXD, FILM:7.5K OHM, 1%, 0.125W	91637	MFF1816G75000F
R3504	321-0164-00			RES., FXD, FILM:4.99 OHM, 1%, 0.125W	91637	MFF1816G499R0F
R3505	311-1280-00			RES., VAR, NONWIR:1K OHM, 10%, 0.50W	32997	3329W-L58-102
R3506	321-0222-00			RES., FXD, FILM:2K OHM, 1%, 0.125W	91637	MFF1816G20000F
R3507	311-1281-00			RES., VAR, NONWIR:2.5K OHM, 10%, 0.5W	32997	3329W-L58-252
R3508	315-0622-00			RES., FXD, CMPSN:6.2K OHM, 5%, 0.25W	01121	CB6225
R3510	311-1280-00			RES., VAR, NONWIR:1K OHM, 10%, 0.50W	32997	3329W-L58-102
R3512	315-0362-00			RES., FXD, CMPSN:3.6K OHM, 5%, 0.25W	01121	CB3625
R3513	321-0260-00	XB020300		RES., FXD, FILM:4.99K OHM, 1%, 0.125W	91637	MFF1816G49900F
R3514	315-0102-00			RES., FXD, CMPSN:1K OHM, 5%, 0.25W	01121	CB1025
R3515	315-0102-00			RES., FXD, CMPSN:1K OHM, 5%, 0.25W	01121	CB1025
R3516	315-0134-00	B010100	B020159	RES., FXD, CMPSN:130K OHM, 5%, 0.25W	01121	CB1345
R3516	321-0383-00	B020160		RES., FXD, FILM:95.3K OHM, 1%, 0.125W	91637	MFF1816G95301F
R3517	315-0103-00			RES., FXD, CMPSN:10K OHM, 5%, 0.25W	01121	CB1035
R3518	315-0123-00			RES., FXD, CMPSN:12K OHM, 5%, 0.25W	01121	CB1235
R3519	311-1286-00	B010100	B020159	RES., VAR, NONWIR:50K OHM, 10%, 0.5W	32997	3329W-L58-503
R3519	311-1287-00	B020160		RES., VAR, NONWIR:TRMR, 100K OHM, 0.50W	32997	3329W-L58-104
R3521	321-0303-00			RES., FXD, FILM:14K OHM, 1%, 0.125W	91637	MFF1816G14001F
R3522	321-0193-00			RES., FXD, FILM:1K OHM, 1%, 0.125W	91637	MFF1816G10000F
R3524	321-0193-00			RES., FXD, FILM:1K OHM, 1%, 0.125W	91637	MFF1816G10000F
R3530	315-0273-00			RES., FXD, CMPSN:27K OHM, 5%, 0.25W	01121	CB2735
R3532	315-0101-00	XB020200		RES., FXD, CMPSN:100 OHM, 5%, 0.25W	01121	CB1015
R3533	315-0152-00			RES., FXD, CMPSN:1.5K OHM, 5%, 0.25W	01121	CB1525
R3534	321-0193-00			RES., FXD, FILM:1K OHM, 1%, 0.125W	91637	MFF1816G10000F
R3535	315-0104-00			RES., FXD, CMPSN:100K OHM, 5%, 0.25W	01121	CB1045
R3536	315-0912-00			RES., FXD, CMPSN:9.1K OHM, 5%, 0.25W	01121	CB9125
R3537	315-0154-00			RES., FXD, CMPSN:150K OHM, 5%, 0.25W	01121	CB1545
R3538	315-0472-00			RES., FXD, CMPSN:4.7K OHM, 5%, 0.25W	01121	CB4725
R3540	321-0251-00			RES., FXD, FILM:4.02K OHM, 1%, 0.125W	91637	MFF1816G40200F
R3550	315-0473-00			RES., FXD, CMPSN:47K OHM, 5%, 0.25W	01121	CB4735
R3555	315-0473-00			RES., FXD, CMPSN:47K OHM, 5%, 0.25W	01121	CB4735
R3557	321-0318-00			RES., FXD, FILM:20K OHM, 1%, 0.125W	91637	MFF1816G20001F
R3559	315-0152-00			RES., FXD, CMPSN:1.5K OHM, 5%, 0.25W	01121	CB1525
R3561	317-0104-00	B010100	B020349	RES., FXD, CMPSN:100K OHM, 5%, 0.125W	01121	BB1045
R3561	317-0471-00	B020350		RES., FXD, CMPSN:470 OHM, 5%, 0.125W	01121	BB4715
R3562	317-0104-00	B010100	B020349	RES., FXD, CMPSN:100K OHM, 5%, 0.125W	01121	BB1045
R3562	317-0471-00	B020350		RES., FXD, CMPSN:470 OHM, 5%, 0.125W	01121	BB4715
R3563	317-0104-00	B010100	B020349	RES., FXD, CMPSN:100K OHM, 5%, 0.125W	01121	BB1045
R3563	317-0471-00	B020350		RES., FXD, CMPSN:470 OHM, 5%, 0.125W	01121	BB4715
R3564	317-0104-00	B010100	B020349	RES., FXD, CMPSN:100K OHM, 5%, 0.125W	01121	BB1045
R3564	317-0471-00	B020350		RES., FXD, CMPSN:470 OHM, 5%, 0.125W	01121	BB4715
R3565	317-0104-00	B010100	B020349	RES., FXD, CMPSN:100K OHM, 5%, 0.125W	01121	BB1045
R3565	317-0471-00	B020350		RES., FXD, CMPSN:470 OHM, 5%, 0.125W	01121	BB4715
R3566	317-0104-00	B010100	B020349	RES., FXD, CMPSN:100K OHM, 5%, 0.125W	01121	BB1045
R3566	317-0471-00	B020350		RES., FXD, CMPSN:470 OHM, 5%, 0.125W	01121	BB4715
R3567	317-0104-00	B010100	B020349	RES., FXD, CMPSN:100K OHM, 5%, 0.125W	01121	BB1045
R3567	317-0471-00	B020350		RES., FXD, CMPSN:470 OHM, 5%, 0.125W	01121	BB4715
R3568	317-0104-00	B010100	B020349	RES., FXD, CMPSN:100K OHM, 5%, 0.125W	01121	BB1045
R3568	317-0471-00	B020350		RES., FXD, CMPSN:470 OHM, 5%, 0.125W	01121	BB4715

Replaceable Electrical Parts—7L18 Service

Ckt No.	Tektronix Part No.	Serial/Model No. Eff	Discont	Name & Description	Mfr Code	Mfr Part Number
R3570	321-0193-00			RES., FXD, FILM:1K OHM, 1%, 0.125W	91637	MFF1816G10000F
R3571	321-0222-00			RES., FXD, FILM:2K OHM, 1%, 0.125W	91637	MFF1816G20000F
R3573	321-0300-00			RES., FXD, FILM:13K OHM, 1%, 0.125W	91637	MFF1816G13001F
R3574	315-0102-00			RES., FXD, CMPSN:1K OHM, 5%, 0.25W	01121	CB1025
R3579	315-0102-00			RES., FXD, CMPSN:1K OHM, 5%, 0.25W	01121	CB1025
R3580	315-0102-00			RES., FXD, CMPSN:1K OHM, 5%, 0.25W	01121	CB1025
R3582	321-0210-00			RES., FXD, FILM:1.5K OHM, 1%, 0.125W	91637	MFF1816G15000F
R3584	321-0402-00			RES., FXD, FILM:150K OHM, 1%, 0.125W	24546	NA55D1503F
R3594	315-0104-00			RES., FXD, CMPSN:100K OHM, 5%, 0.25W	01121	CB1045
R3595	321-0193-00			RES., FXD, FILM:1K OHM, 1%, 0.125W	91637	MFF1816G10000F
R3598	315-0153-00			RES., FXD, CMPSN:15K OHM, 5%, 0.25W	01121	CB1535
R3599	315-0104-00			RES., FXD, CMPSN:100K OHM, 5%, 0.25W	01121	CB1045
R3610	315-0103-00			RES., FXD, CMPSN:10K OHM, 5%, 0.25W	01121	CB1035
R3617	315-0302-00			RES., FXD, CMPSN:3K OHM, 5%, 0.25W	01121	CB3025
R3650	315-0104-00			RES., FXD, CMPSN:100K OHM, 5%, 0.25W	01121	CB1045
R3652	315-0473-00	B010100	B010137	RES., FXD, CMPSN:47K OHM, 5%, 0.25W	01121	CB4735
R3652	315-0104-00	B010138		RES., FXD, CMPSN:100K OHM, 5%, 0.25W	01121	CB1045
R3656	315-0473-00			RES., FXD, CMPSN:47K OHM, 5%, 0.25W	01121	CB4735
R3658	315-0473-00			RES., FXD, CMPSN:47K OHM, 5%, 0.25W	01121	CB4735
S100	260-0960-01			SWITCH, SLIDE:0.5A, 120VDC, CKT BD MT	10389	23-021-043
S138	263-0019-00	B010100	B020449	SWITCH PB ASSY:MOMENTARY	80009	263-0019-00
S138	263-0019-09	B020450		SWITCH PB ASSY:MOMENTARY	80009	263-0019-09
S140	263-0019-00	B010100	B020449	SWITCH PB ASSY:MOMENTARY	80009	263-0019-00
S140	263-0019-09	B020450		SWITCH PB ASSY:MOMENTARY	80009	263-0019-09
S144	263-0019-00	B010100	B020449	SWITCH PB ASSY:MOMENTARY	80009	263-0019-00
S144	263-0019-09	B020450		SWITCH PB ASSY:MOMENTARY	80009	263-0019-09
S146	263-0019-00	B010100	B020449	SWITCH PB ASSY:MOMENTARY	80009	263-0019-00
S146	263-0019-09	B020450		SWITCH PB ASSY:MOMENTARY	80009	263-0019-09
S150	263-0019-00	B010100	B020449	SWITCH PB ASSY:MOMENTARY	80009	263-0019-00
S150	263-0019-09	B020450		SWITCH PB ASSY:MOMENTARY	80009	263-0019-09
S154	263-0019-00	B010100	B020449	SWITCH PB ASSY:MOMENTARY	80009	263-0019-00
S154	263-0019-09	B020450		SWITCH PB ASSY:MOMENTARY	80009	263-0019-09
S162	263-0019-00	B010100	B020449	SWITCH PB ASSY:MOMENTARY	80009	263-0019-00
S162	263-0019-09	B020450		SWITCH PB ASSY:MOMENTARY	80009	263-0019-09
S164	263-0019-00	B010100	B020449	SWITCH PB ASSY:MOMENTARY	80009	263-0019-00
S164	263-0019-09	B020450		SWITCH PB ASSY:MOMENTARY	80009	263-0019-09
S166	263-0019-00	B010100	B020449	SWITCH PB ASSY:MOMENTARY	80009	263-0019-00
S166	263-0019-09	B020450		SWITCH PB ASSY:MOMENTARY	80009	263-0019-09
S168	263-0019-00	B010100	B020449	SWITCH PB ASSY:MOMENTARY	80009	263-0019-00
S168	263-0019-09	B020450		SWITCH PB ASSY:MOMENTARY	80009	263-0019-09
S178	263-0019-00	B010100	B020449	SWITCH PB ASSY:MOMENTARY	80009	263-0019-00
S178	263-0019-09	B020450		SWITCH PB ASSY:MOMENTARY	80009	263-0019-09
S180	263-0019-00	B010100	B020449	SWITCH PB ASSY:MOMENTARY	80009	263-0019-00
S180	263-0019-09	B020450		SWITCH PB ASSY:MOMENTARY	80009	263-0019-09
S182	263-0019-00	B010100	B020449	SWITCH PB ASSY:MOMENTARY	80009	263-0019-00
S182	263-0019-09	B020450		SWITCH PB ASSY:MOMENTARY	80009	263-0019-09
S184	263-0019-00	B010100	B020449	SWITCH PB ASSY:MOMENTARY	80009	263-0019-00
S184	263-0019-09	B020450		SWITCH PB ASSY:MOMENTARY	80009	263-0019-09
S186	263-0019-00	B010100	B020449	SWITCH PB ASSY:MOMENTARY	80009	263-0019-00
S186	263-0019-09	B020450		SWITCH PB ASSY:MOMENTARY	80009	263-0019-09
S188	263-0019-00	B010100	B020449	SWITCH PB ASSY:MOMENTARY	80009	263-0019-00
S188	263-0019-09	B020450		SWITCH PB ASSY:MOMENTARY	80009	263-0019-09
S190	263-0019-00	B010100	B020449	SWITCH PB ASSY:MOMENTARY	80009	263-0019-00
S190	263-0019-09	B020450		SWITCH PB ASSY:MOMENTARY	80009	263-0019-09
S200	263-0059-00			SW ROTARY ASSY:PANCAKE, BANDWIDTH	80009	263-0059-00
S210	263-0060-00			SW ROTARY ASSY:PANCAKE, TIME/DIVISION	80009	263-0060-00

Ckt No.	Tektronix Part No.	Serial/Model No. Eff	Dscont	Name & Description	Mfr Code	Mfr Part Number
S220	263-0061-00			SW ROTARY ASSY:PANCAKE,SPAN/DIVISION	80009	263-0061-00
S2500	260-1852-00	B010100	B020199	SWITCH,PUSH:6 POLE,3 BUTTON	80009	260-1852-00
S2510						
S2520						
S2500	260-1852-01	B020200		SWITCH,PUSH:6 POLE,3 BUTTON	80009	260-1852-01
S2510						
S2520	260-1851-00	B010100	B020199	SWITCH,PUSH:2 POLE,SGL BUTTON	80009	260-1851-00
S2530	260-1851-01	B020200		SWITCH,PUSH:2 POLE,SGL BUTTON	80009	260-1851-01
S2901	-----			(FURNISHED AS A UNIT WITH 672-0589-00)		
S2903	-----			(FURNISHED AS A UNIT WITH 672-0589-00)		
T948	120-1011-00			XFMR,RF:TOROID,3 WINDINGS,TRIFILAR	80009	120-1011-00
T990	120-1011-00			XFMR,RF:TOROID,3 WINDINGS,TRIFILAR	80009	120-1011-00
T992	120-1011-00			XFMR,RF:TOROID,3 WINDINGS,TRIFILAR	80009	120-1011-00
T1062	120-1111-00			XFMR,RF:TOROID,2 WINDS	80009	120-1111-00
T1150	-----			(FURNISHED AS A UNIT WITH A940A7A2)		
T2379	120-1112-00			XFMR,RF:TOROID,2 WINDS	80009	120-1112-00
T2380	120-0318-00			XFMR,TOROID:6 TURNS BIFILAR	80009	120-0318-00
T2388	120-0318-00			XFMR,TOROID:6 TURNS BIFILAR	80009	120-0318-00
T2390	120-0318-00			XFMR,TOROID:6 TURNS BIFILAR	80009	120-0318-00
T2470	120-1113-00			XFMR,RF:BALUN,TD-343	80009	120-1113-00
T3002	120-0774-00			XFMR,TOROID:2 WINDINGS	80009	120-0774-00
T3006	120-0774-00			XFMR,TOROID:2 WINDINGS	80009	120-0774-00
T3014	120-0774-00			XFMR,TOROID:2 WINDINGS	80009	120-0774-00
T3044	120-0775-00			XFMR,TOROID:2 WINDINGS	80009	120-0775-00
T3090	120-0772-00			XFMR,TOROID:2 WINDINGS	80009	120-0772-00
T3100	120-0775-00			XFMR,TOROID:2 WINDINGS	80009	120-0775-00
T3130	120-0902-00			XFMR,TOROID:5 TURNS,BIFILAR	80009	120-0902-00
T3132	120-0903-00			XFMR,TOROID:3 WINDINGS,TRIFILAR	80009	120-0903-00
T3266	120-0773-00			XFMR,TOROID:2 WINDINGS	80009	120-0773-00
T3280	120-0774-00			XFMR,TOROID:2 WINDINGS	80009	120-0774-00
U100	156-0795-00			MICROCIRCUIT,DI:BCD 7-SEG LCHDCDR/DRVR	04713	MC14511BCL
U130	156-0387-00			MICROCIRCUIT,DI:DUAL J-K NEG EDGE TRIG	80009	156-0387-00
U170	156-0388-00			MICROCIRCUIT,DI:DUAL D-TYPE FLIP-FLOP	80009	156-0388-00
U200	156-0469-00			MICROCIRCUIT,DI:3-LINE TO 8-LINE DECODER	01295	SN74LS138N
U205	156-0951-00			MICROCIRCUIT,DI:QUAD D RGSTR	27014	DM74LS173N OR J
U210	156-0391-00			MICROCIRCUIT,DI:HEX LATCH WITH CLEAR	04713	74LS174(N OR J)
U215	156-0469-00			MICROCIRCUIT,DI:3-LINE TO 8-LINE DECODER	01295	SN74LS138N
U220	156-0469-00			MICROCIRCUIT,DI:3-LINE TO 8-LINE DECODER	01295	SN74LS138N
U225	156-0382-00			MICROCIRCUIT,DI:QUAD 2-INPUT NAND GATE	01295	SN74LS00(N OR J)
U230	156-0388-00			MICROCIRCUIT,DI:DUAL D-TYPE FLIP-FLOP	80009	156-0388-00
U235	156-0388-00			MICROCIRCUIT,DI:DUAL D-TYPE FLIP-FLOP	80009	156-0388-00
U240	156-0388-00			MICROCIRCUIT,DI:DUAL D-TYPE FLIP-FLOP	80009	156-0388-00
U245	156-0388-00			MICROCIRCUIT,DI:DUAL D-TYPE FLIP-FLOP	80009	156-0388-00
U250	156-0512-00	B010100	B010249	MICROCIRCUIT,LI:OPERATIONAL AMPLIFIER	27014	LM308N
U250	156-0512-02	B010250		MICROCIRCUIT,LI:OPERATIONAL AMPLIFIER,SEL	04713	LM308J-8DS
U305	156-0971-06	B010100	B010131X	MICROCIRCUIT,DI:512 X 8 PROM OPEN COLL	80009	156-0971-06
U311	156-0971-05	B010100	B010131X	MICROCIRCUIT,DI:512 X 8 PROM OPEN COLL	80009	156-0971-05
U321	156-0158-00			MICROCIRCUIT,LI:DUAL OPERATIONAL AMPLIFIER	18324	MC1458N
U325	156-0971-04	B010100	B010131X	MICROCIRCUIT,DI:512 X 8 PROM OPEN COLL	80009	156-0971-04
U330	156-0971-03	B010100	B010131X	MICROCIRCUIT,DI:512 X 8 PROM OPEN COLL	80009	156-0971-03
U335	156-0350-00			MICROCIRCUIT,DI:QUAD 2-INPUT NAND GATE	80009	156-0350-00
U340	156-0330-00			MICROCIRCUIT,DI:HEX.BUFFER	80009	156-0330-00
U345	156-0971-02	B010100	B010131X	MICROCIRCUIT,DI:512 X 8 PROM OPEN COLLECTOR	80009	156-0971-02
U350	156-0803-00			MICROCIRCUIT,DI:4-BIT,P-CHAN MICROPROCESSOR	80009	156-0803-00
U355	156-0931-00			MICROCIRCUIT,DI:QUAD D FF	80009	156-0931-00

Replaceable Electrical Parts—7L18 Service

Ckt No.	Tektronix Part No.	Serial/Model No. Eff	Dscont	Name & Description	Mfr Code	Mfr Part Number
U360	156-0971-01	B010100	B010131X	MICROCIRCUIT,DI:512 X 8 PROM OPEN COLLECTOR	80009	156-0971-01
U365	156-1113-00			MICROCIRCUIT,DI:STANDARD MEMORY INTERFACE	80009	156-1113-00
U367	156-1128-00	XB010131		MICROCIRCUIT,DI:2048 X 8 ROM,CUSTOM MASK	80009	156-1128-00
U369	156-1129-00	XB010131		MICROCIRCUIT,DI:2048 X 8 ROM,CUSTOM MASK	80009	156-1129-00
U370	156-0469-00	B010100	B010131X	MICROCIRCUIT,DI:3-LINE TO 8-LINE DECODER	01295	SN74LS138N
U371	156-0800-00	XB010131		MICROCIRCUIT,DI:QUAD LATCH	04713	MC14042BCL
U374	156-0349-00	XB010131		MICROCIRCUIT,DI:QUAD 2-INPUT NOR GATE	27014	CD4001CJ
U375	156-0797-00			MICROCIRCUIT,DI:320 BIT RAM,4BIT OUT	80009	156-0797-00
U376	156-0568-00	XB010131		MICROCIRCUIT,DI:STATIC SHIFT	02735	CD4014AE
U380	156-0494-00			MICROCIRCUIT,DI:HEX INVERTER/BUFFER	80009	156-0494-00
U385	156-0535-00			MICROCIRCUIT,DI:TRI-STATE HEX BUFF	27014	DM8097M
U450	156-0512-00	B010100	B010249	MICROCIRCUIT,LI:OPERATIONAL AMPLIFIER	27014	LM308N
U450	156-0512-02	B010250		MICROCIRCUIT,LI:OPERATIONAL AMPLIFIER,SEL	04713	LM308J-8DS
U455	156-0512-00	B010100	B010249	MICROCIRCUIT,LI:OPERATIONAL AMPLIFIER	27014	LM308N
U455	156-0512-02	B010250		MICROCIRCUIT,LI:OPERATIONAL AMPLIFIER,SEL	04713	LM308J-8DS
U470	156-0512-00	B010100	B010249	MICROCIRCUIT,LI:OPERATIONAL AMPLIFIER	27014	LM308N
U470	156-0512-02	B010250		MICROCIRCUIT,LI:OPERATIONAL AMPLIFIER,SEL	04713	LM308J-8DS
U475	156-0096-00			MICROCIRCUIT,LI:VOLTAGE COMPARATOR	27014	LM311H
U480	156-0366-00			MICROCIRCUIT,DI:DUAL D-TYPE F-F	80009	156-0366-00
U490	156-0306-00			MICROCIRCUIT,DI:4.5 DECADE COUNTER	07263	A7R381R19X
U500	156-0469-00			MICROCIRCUIT,DI:3-LINE TO 8-LINE DECODER	01295	SN74LS138N
U505	156-0469-00			MICROCIRCUIT,DI:3-LINE TO 8-LINE DECODER	01295	SN74LS138N
U510	156-0349-00			MICROCIRCUIT,DI:QUAD 2-INPUT NOR GATE	27014	CD4001CJ
U520	156-0512-00	B010100	B010249	MICROCIRCUIT,LI:OPERATIONAL AMPLIFIER	27014	LM308N
U520	156-0512-02	B010250		MICROCIRCUIT,LI:OPERATIONAL AMPLIFIER,SEL	04713	LM308J-8DS
U525	156-0494-00			MICROCIRCUIT,DI:HEX INVERTER/BUFFER	80009	156-0494-00
U540	156-0186-00			MICROCIRCUIT,DI:QUAD 2-INPUT NAND GATE	01295	SN7403N
U545	156-0186-00			MICROCIRCUIT,DI:QUAD 2-INPUT NAND GATE	01295	SN7403N
U730	156-0800-00			MICROCIRCUIT,DI:QUAD LATCH	04713	MC14042BCL
U825	155-0035-00			MICROCIRCUIT,LI:QUAD OPERATIONAL AMPL	80009	155-0035-00
U1010	156-0331-02			MICROCIRCUIT,DI:DUAL D EDGE TRIGGERED FLIP	80009	156-0331-02
U1015	156-0180-00			MICROCIRCUIT,DI:QUAD 2-INPUT NAND GATE	01295	SN74800(N OR J)
U1020	156-0317-00			MICROCIRCUIT,LI:OPERATIONAL AMPLIFIER	34371	HA2-2625-5
U1105	156-0331-02			MICROCIRCUIT,DI:DUAL D EDGE TRIGGERED FLIP	80009	156-0331-02
U1120	156-0366-00			MICROCIRCUIT,DI:DUAL D-TYPE F-F	80009	156-0366-00
U1135	156-0105-00	B010100	B010249	MICROCIRCUIT,LI:OPERATIONAL AMPLIFIER	27014	LM301AN
U1135	156-0105-02	B010250		MICROCIRCUIT,LI:OPERATIONAL AMPLIFIER,SEL	01295	LM301AJG4
U1140	156-0105-00	B010100	B010249	MICROCIRCUIT,LI:OPERATIONAL AMPLIFIER	27014	LM301AN
U1140	156-0105-02	B010250		MICROCIRCUIT,LI:OPERATIONAL AMPLIFIER,SEL	01295	LM301AJG4
U1155	156-0388-00			MICROCIRCUIT,DI:DUAL D-TYPE FLIP-FLOP	80009	156-0388-00
U1160	156-0388-00			MICROCIRCUIT,DI:DUAL D-TYPE FLIP-FLOP	80009	156-0388-00
U1165	156-0388-00			MICROCIRCUIT,DI:DUAL D-TYPE FLIP-FLOP	80009	156-0388-00
U1180	156-0578-00			MICROCIRCUIT,DI:DUAL 1 SHOT MULTIVIBRATOR	80009	156-0578-00
U1190	156-0350-00			MICROCIRCUIT,DI:QUAD 2-INPUT NAND GATE	80009	156-0350-00
U1205	156-0105-00	B010100	B010249	MICROCIRCUIT,LI:OPERATIONAL AMPLIFIER	27014	LM301AN
U1205	156-0105-02	B010250		MICROCIRCUIT,LI:OPERATIONAL AMPLIFIER,SEL	01295	LM301AJG4
U1210	156-0349-00			MICROCIRCUIT,DI:QUAD 2-INPUT NOR GATE	27014	CD4001CJ
U1215	156-0582-00			MICROCIRCUIT,DI:BINARY UP/DOWN COUNTER	04713	MC14516BCL
U1218	156-0158-00			MICROCIRCUIT,LI:DUAL OPERATIONAL AMPLIFIER	18324	MC1458N
U1220	156-0366-00			MICROCIRCUIT,DI:DUAL D-TYPE F-F	80009	156-0366-00
U1225	156-0582-00			MICROCIRCUIT,DI:BINARY UP/DOWN COUNTER	04713	MC14516BCL
U1230	156-0105-00	B010100	B010249	MICROCIRCUIT,LI:OPERATIONAL AMPLIFIER	27014	LM301AN
U1230	156-0105-02	B010250		MICROCIRCUIT,LI:OPERATIONAL AMPLIFIER,SEL	01295	LM301AJG4
U1235	307-0479-00			RES NTWK,FILM:LADDER 40K,80K & 78.5K OHM	80009	307-0479-00
U1245	156-0411-00	B010100	B010249	MICROCIRCUIT,LI:QUAD-COMP,SGL SUPPLY	27014	LM339N
U1245	156-0411-02	B010250		MICROCIRCUIT,LI:QUAD COMPARTOR,SEL	04713	LM339JDS
U1265	156-0799-00			MICROCIRCUIT,DI:DECADE CNTR/DTV	80009	156-0799-00

Ckt No.	Tektronix Part No.	Serial/Model No. Eff	Dscont	Name & Description	Mfr Code	Mfr Part Number
U1270	156-0756-00			MICROCIRCUIT,DI:BCD TO DECIMAL DECODER	80009	156-0756-00
U1275	156-0801-00			MICROCIRCUIT,DI:DUAL 4 BIT STATIC SR	04713	MC14015BCL
U1280	156-0801-00			MICROCIRCUIT,DI:DUAL 4 BIT STATIC SR	04713	MC14015BCL
U1285	156-0350-00			MICROCIRCUIT,DI:QUAD 2-INPUT NAND GATE	80009	156-0350-00
U1290	156-0514-00			MICROCIRCUIT,DI:DIFF 4-CHAN MUX	80009	156-0514-00
U1295	156-0366-00			MICROCIRCUIT,DI:DUAL D-TYPE F-F	80009	156-0366-00
U1300	156-0742-00	B010100	B010249	MICROCIRCUIT,LI:OPERATIONAL AMPLIFIER	27014	LM318N
U1300	156-0742-02	B010250		MICROCIRCUIT,LI:OPERATIONAL AMPLIFIER,SEL	01295	LM318P3
U1310	156-0067-00			MICROCIRCUIT,LI:OPERATIONAL AMPLIFIER	02735	85145
U1325	156-0685-00			MICROCIRCUIT,LI:OPERATIONAL AMPLIFIER	27014	LM725CN
U1340	156-0719-00			MICROCIRCUIT,LI:10 BIT MULTIPLYING DAC	24355	AD7533LN
U1350	156-0685-00			MICROCIRCUIT,LI:OPERATIONAL AMPLIFIER	27014	LM725CN
U1390	155-0035-00			MICROCIRCUIT,LI:QUAD OPERATIONAL AMPL	80009	155-0035-00
U1410	156-0411-00	B010100	B010249	MICROCIRCUIT,LI:QUAD-COMP,SGL SUPPLY	27014	LM339N
U1410	156-0411-02	B010250		MICROCIRCUIT,LI:QUAD COMPARATOR,SEL	04713	LM339JDS
U1450	156-0158-00			MICROCIRCUIT,LI:DUAL OPERATIONAL AMPLIFIER	18324	MC1458N
U1480	155-0056-00			MICROCIRCUIT,DI:SWEEP CONTROL	80009	155-0056-00
U1520	156-0756-00			MICROCIRCUIT,DI:BCD TO DECIMAL DECODER	80009	156-0756-00
U1525	156-0350-00			MICROCIRCUIT,DI:QUAD 2-INPUT NAND GATE	80009	156-0350-00
U1530	156-0801-00			MICROCIRCUIT,DI:DUAL 4 BIT STATIC SR	04713	MC14015BCL
U1540	156-0513-00			MICROCIRCUIT,DI:8-CHAN MUX	80009	156-0513-00
U1545	156-0514-00			MICROCIRCUIT,DI:DIFF 4-CHAN MUX	80009	156-0514-00
U1560	155-0028-00			MICROCIRCUIT,LI:ML,MILLER INTEGRATOR	80009	155-0028-00
U1595	156-0512-00	B010100	B010249	MICROCIRCUIT,LI:OPERATIONAL AMPLIFIER	27014	LM308N
U1595	156-0512-02	B010250		MICROCIRCUIT,LI:OPERATIONAL AMPLIFIER,SEL	04713	LM308J-8DS
U1610	156-0067-00			MICROCIRCUIT,LI:OPERATIONAL AMPLIFIER	02735	85145
U1650	156-0793-00			MICROCIRCUIT,DI:DUAL 4-INP NAND GATE	04713	MC14012BCL
U1655	156-0756-00			MICROCIRCUIT,DI:BCD TO DECIMAL DECODER	80009	156-0756-00
U1660	156-0350-00			MICROCIRCUIT,DI:QUAD 2-INPUT NAND GATE	80009	156-0350-00
U1665	156-0505-00			MICROCIRCUIT,DI:4 BIT AND/OR SEL	04713	MC14519BCL
U1666	156-0349-00	XB020630		MICROCIRCUIT,DI:QUAD 2-INPUT NOR GATE	27014	CD4001CJ
U1670	156-0681-00			MICROCIRCUIT,DI:18 STAGE STATIC SHIFT RGTR	80009	156-0681-00
U1675	156-0681-00			MICROCIRCUIT,DI:18 STAGE STATIC SHIFT RGTR	80009	156-0681-00
U1680	156-0350-00			MICROCIRCUIT,DI:QUAD 2-INPUT NAND GATE	80009	156-0350-00
U1685	156-0350-00			MICROCIRCUIT,DI:QUAD 2-INPUT NAND GATE	80009	156-0350-00
U1690	156-0289-00			MICROCIRCUIT,DI:QUAD BILATERAL SWITCH	07263	74LS95(PC OR DC)
U1695	156-0289-00			MICROCIRCUIT,DI:QUAD BILATERAL SWITCH	07263	74LS95(PC OR DC)
U1700	156-0349-00			MICROCIRCUIT,DI:QUAD 2-INPUT NOR GATE	27014	CD4001CJ
U1705	156-0799-00			MICROCIRCUIT,DI:DECADE CNTR/DTV	80009	156-0799-00
U1710	156-0799-00			MICROCIRCUIT,DI:DECADE CNTR/DTV	80009	156-0799-00
U1715	156-0366-00			MICROCIRCUIT,DI:DUAL D-TYPE F-F	80009	156-0366-00
U1720	156-0350-00			MICROCIRCUIT,DI:QUAD 2-INPUT NAND GATE	80009	156-0350-00
U1725	156-0350-00			MICROCIRCUIT,DI:QUAD 2-INPUT NAND GATE	80009	156-0350-00
U1730	156-0578-00			MICROCIRCUIT,DI:DUAL 1 SHOT MULTIVIBRATOR	80009	156-0578-00
U1735	156-0801-00			MICROCIRCUIT,DI:DUAL 4 BIT STATIC SR	04713	MC14015BCL
U1740	156-0494-00			MICROCIRCUIT,DI:HEX INVERTER/BUFFER	80009	156-0494-00
U1745	156-0577-00			MICROCIRCUIT,DI:QUAD 2 INPUT AND GATE	80009	156-0577-00
U1749	156-0753-00			MICROCIRCUIT,DI:EXPAN 4-W 2-INP AOI GATE	80009	156-0753-00
U1750	156-0505-00			MICROCIRCUIT,DI:4 BIT AND/OR SEL	04713	MC14519BCL
U1752	156-0624-00			MICROCIRCUIT,LI:CRYSTAL OSC	04713	MC12061P
U1754	156-0681-00			MICROCIRCUIT,DI:18 STAGE STATIC SHIFT RGTR	80009	156-0681-00
U1756	156-0681-00			MICROCIRCUIT,DI:18 STAGE STATIC SHIFT RGTR	80009	156-0681-00
U1758	156-0494-00			MICROCIRCUIT,DI:HEX INVERTER/BUFFER	80009	156-0494-00
U1780	156-0350-00			MICROCIRCUIT,DI:QUAD 2-INPUT NAND GATE	80009	156-0350-00
U1782	156-0350-00			MICROCIRCUIT,DI:QUAD 2-INPUT NAND GATE	80009	156-0350-00
U1814	156-0289-00			MICROCIRCUIT,DI:QUAD BILATERAL SWITCH	07263	74LS95(PC OR DC)
U1818	156-0289-00			MICROCIRCUIT,DI:QUAD BILATERAL SWITCH	07263	74LS95(PC OR DC)

Replaceable Electrical Parts—7L18 Service

Ckt No.	Tektronix Part No.	Serial/Model No. Eff	Dscont	Name & Description	Mfr Code	Mfr Part Number
U1820	156-0289-00			MICROCIRCUIT,DI:QUAD BILATERAL SWITCH	07263	74LS95(PC OR DC)
U1832	156-0801-00			MICROCIRCUIT,DI:DUAL 4 BIT STATIC SR	04713	MC14015BCL
U1834	156-0801-00			MICROCIRCUIT,DI:DUAL 4 BIT STATIC SR	04713	MC14015BCL
U1836	156-0289-00			MICROCIRCUIT,DI:QUAD BILATERAL SWITCH	07263	74LS95(PC OR DC)
U1838	156-0289-00			MICROCIRCUIT,DI:QUAD BILATERAL SWITCH	07263	74LS95(PC OR DC)
U1896	156-0289-00			MICROCIRCUIT,DI:QUAD BILATERAL SWITCH	07263	74LS95(PC OR DC)
U1906	156-0289-00			MICROCIRCUIT,DI:QUAD BILATERAL SWITCH	07263	74LS95(PC OR DC)
U1970	156-0513-00			MICROCIRCUIT,DI:8-CHAN MUX	80009	156-0513-00
U2000	156-0685-00			MICROCIRCUIT,LI:OPERATIONAL AMPLIFIER	27014	LM725CN
U2020	156-0513-00			MICROCIRCUIT,DI:8-CHAN MUX	80009	156-0513-00
U2060	156-0420-00			MICROCIRCUIT,LI:PREAMPLIFIER	27014	LM321H
U2065	156-0512-00	B010100	B010249	MICROCIRCUIT,LI:OPERATIONAL AMPLIFIER	27014	LM308N
U2065	156-0512-02	B010250		MICROCIRCUIT,LI:OPERATIONAL AMPLIFIER,SEL	04713	LM308J-8DS
U2110	156-0800-00			MICROCIRCUIT,DI:QUAD LATCH	04713	MC14042BCL
U2120	156-0350-00			MICROCIRCUIT,DI:QUAD 2-INPUT NAND GATE	80009	156-0350-00
U2155	156-0512-00	B010100	B010249	MICROCIRCUIT,LI:QUAD COMPARATOR,SEL	27014	LM308N
U2155	156-0512-02	B010250		MICROCIRCUIT,LI:OPERATIONAL AMPLIFIER,SEL	04713	LM308J-8DS
U2160	156-0685-00			MICROCIRCUIT,LI:OPERATIONAL AMPLIFIER	27014	LM725CN
U2190	156-0512-00	B010100	B010249	MICROCIRCUIT,LI:OPERATIONAL AMPLIFIER	27014	LM308N
U2190	156-0512-02	B010250		MICROCIRCUIT,LI:OPERATIONAL AMPLIFIER,SEL	04713	LM308J-8DS
U2220	156-0800-00			MICROCIRCUIT,DI:QUAD LATCH	04713	MC14042BCL
U2260	156-0411-00	B010100	B010249	MICROCIRCUIT,LI:QUAD-COMP, SGL SUPPLY	27014	LM339N
U2260	156-0411-02	B010250		MICROCIRCUIT,LI:QUAD COMPARATOR,SEL	04713	LM339JDS
U2270	156-0105-00	B010100	B010249	MICROCIRCUIT,LI:OPERATIONAL AMPLIFIER	27014	LM301AN
U2270	156-0105-02	B010250		MICROCIRCUIT,LI:OPERATIONAL AMPLIFIER,SEL	01295	LM301AJG4
U2320	156-0512-00	B010100	B010249	MICROCIRCUIT,LI:OPERATIONAL AMPLIFIER	27014	LM308N
U2320	156-0512-02	B010250		MICROCIRCUIT,LI:OPERATIONAL AMPLIFIER,SEL	04713	LM308J-8DS
U2340	156-0512-00	B010100	B010249	MICROCIRCUIT,LI:OPERATIONAL AMPLIFIER	27014	LM308N
U2340	156-0512-02	B010250		MICROCIRCUIT,LI:OPERATIONAL AMPLIFIER,SEL	04713	LM308J-8DS
U2490	156-0512-00	B010100	B010249	MICROCIRCUIT,LI:OPERATIONAL AMPLIFIER	27014	LM308N
U2490	156-0512-02	B010250		MICROCIRCUIT,LI:OPERATIONAL AMPLIFIER,SEL	04713	LM308J-8DS
U2550	156-0801-00			MICROCIRCUIT,DI:DUAL 4 BIT STATIC SR	04713	MC14015BCL
U2560	156-0801-00			MICROCIRCUIT,DI:DUAL 4 BIT STATIC SR	04713	MC14015BCL
U2570	156-0513-00			MICROCIRCUIT,DI:8-CHAN MUX	80009	156-0513-00
U2590	156-0158-00			MICROCIRCUIT,LI:DUAL OPERATIONAL AMPLIFIER	18324	MC1458N
U2600	156-0469-00			MICROCIRCUIT,DI:3-LINE TO 8-LINE DECODER	01295	SN74LS138N
U2610	156-0469-00			MICROCIRCUIT,DI:3-LINE TO 8-LINE DECODER	01295	SN74LS138N
U2640	156-0795-00			MICROCIRCUIT,DI:BCD 7-SEG LCHDCDR/DRVR	04713	MC14511BCL
U2660	156-0330-00			MICROCIRCUIT,DI:HEX. BUFFER	80009	156-0330-00
U2810	156-0105-00	B010100	B010249	MICROCIRCUIT,LI:OPERATIONAL AMPLIFIER	27014	LM301AN
U2810	156-0105-02	B010250		MICROCIRCUIT,LI:OPERATIONAL AMPLIFIER,SEL	01295	LM301AJG4
U2830	156-0686-00			MICROCIRCUIT,LI:OPNL AMPL,HIGH IMPEDANCE	02735	CA3130S
U3360	156-0513-00			MICROCIRCUIT,DI:8-CHAN MUX	80009	156-0513-00
U3480	156-0077-00			MICROCIRCUIT,LI:OPERATIONAL AMPLIFIER	27014	LM301AH
U3500	156-0495-00			MICROCIRCUIT,LI:OPNL AMPL	27014	LM324N
U3510	156-0742-00	B010100	B010249	MICROCIRCUIT,LI:OPERATIONAL AMPLIFIER	27014	LM318N
U3510	156-0742-02	B010250		MICROCIRCUIT,LI:OPERATIONAL AMPLIFIER,SEL	01295	LM318P3
U3515	156-0570-00			MICROCIRCUIT,LI:DUAL HIGH SPEED COMPARATOR	27014	LM319H
U3520	156-0509-00			MICROCIRCUIT,DI:8-BIT BINARY,MULT CUR	04713	MC1408L8
U3526	155-0157-00			MICROCIRCUIT,DI:DIGITAL STORAGE VERTICAL	80009	155-0157-00
U3530	156-0577-00	B010100	B020199	MICROCIRCUIT,DI:QUAD 2 INPUT AND GATE	80009	156-0577-00
U3530	156-0480-00	B020200		MICROCIRCUIT,DI:QUAD 2-INPUT AND GATE	01295	SN74LS08(N OR J)
U3533	156-0846-00			MICROCIRCUIT,LI:VOLTAGE REGULATOR	04713	MC7905CT
U3535	156-0509-00			MICROCIRCUIT,DI:8-BIT BINARY,MULT CUR	04713	MC1408L8
U3537	156-0742-00	B010100	B010249	MICROCIRCUIT,LI:OPERATIONAL AMPLIFIER	27014	LM318N
U3537	156-0742-02	B010250		MICROCIRCUIT,LI:OPERATIONAL AMPLIFIER,SEL	01295	LM318P3
U3539	156-0767-00			MICROCIRCUIT,DI:HEX GATE	04713	MC14572UBCP OR L

Ckt No.	Tektronix	Serial/Model No.		Name & Description	Mfr	Mfr Part Number
	Part No.	Eff	Dscont		Code	
U3540	156-0742-00	B010100	B010249	MICROCIRCUIT,LI:OPERATIONAL AMPLIFIER	27014	LM318N
U3540	156-0742-02	B010250		MICROCIRCUIT,LI:OPERATIONAL AMPLIFIER,SEL	01295	LM318P3
U3545	156-0742-00	B010100	B010249	MICROCIRCUIT,LI:OPERATIONAL AMPLIFIER	27014	LM318N
U3545	156-0742-02	B010250		MICROCIRCUIT,LI:OPERATIONAL AMPLIFIER,SEL	01295	LM318P3
U3550	156-0515-00			MICROCIRCUIT,DI:TRIPLE 3-CHAN MUX	80009	156-0515-00
U3560	156-0515-00			MICROCIRCUIT,DI:TRIPLE 3-CHAN MUX	80009	156-0515-00
U3566	156-0869-00	B010100	B020349	MICROCIRCUIT,DI:8 CHANNEL DGTL MUXER	80009	156-0869-00
U3566	156-0994-00	B020350		MICROCIRCUIT,DI:8 INPUT DATA SEL/MUX	01295	SN74LS151N OR J
U3570	156-0927-00			MICROCIRCUIT,LI:DIGITAL TO ANALOG CONVERTER	80009	156-0927-00
U3580	156-0570-00			MICROCIRCUIT,LI:DUAL HIGH SPEED COMPARATOR	27014	LM319H
U3585	155-0158-00			MICROCIRCUIT,DI:DIGITAL STORAGE HORIZONTAL	80009	155-0158-00
U3587	156-0987-00			MICROCIRCUIT,DI:4096 X 1 STATIC R/W RAM	80009	156-0987-00
U3590	156-0987-00			MICROCIRCUIT,DI:4096 X 1 STATIC R/W RAM	80009	156-0987-00
U3593	156-0682-00			MICROCIRCUIT,DI:HEX D FLIP-FLOP	80009	156-0682-00
U3594	156-0682-00			MICROCIRCUIT,DI:HEX D FLIP-FLOP	80009	156-0682-00
U3595	156-0927-00			MICROCIRCUIT,LI:DIGITAL TO ANALOG CONVERTER	80009	156-0927-00
U3600	156-0767-00			MICROCIRCUIT,DI:HEX GATE	04713	MC14572UBCP OR L
U3605	156-0366-00			MICROCIRCUIT,DI:DUAL D-TYPE F-F	80009	156-0366-00
U3610	156-0349-00	B010100	B020499	MICROCIRCUIT,DI:QUAD 2-INPUT NOR GATE	27014	CD4001CJ
U3610	156-0349-01	B020500		MICROCIRCUIT,DI:QUAD 2-INPUT NOR GATE	80009	156-0349-01
U3615	156-0649-00			MICROCIRCUIT,DI:3 STATE HEX. NON INVT BFR	80009	156-0649-00
U3617	156-0649-00			MICROCIRCUIT,DI:3 STATE HEX. NON INVT BFR	80009	156-0649-00
U3620	156-0545-00			MICROCIRCUIT,DI:12-BIT BINARY COUNTER	80009	156-0545-00
U3625	156-0572-00	B010100	B020499	MICROCIRCUIT,DI:8 BIT SERIAL IN-PRL OUT	80009	156-0572-00
U3625	156-0651-00	B020500		MICROCIRCUIT,DI:8-BIT PRL-OUT,SER SHF RGTR	01295	SN74LS164N
U3630	156-0951-00			MICROCIRCUIT,DI:QUAD D RGSTR	27014	DM74LS173N OR J
U3635	156-0951-00			MICROCIRCUIT,DI:QUAD D RGSTR	27014	DM74LS173N OR J
U3640	156-0951-00			MICROCIRCUIT,DI:QUAD D RGSTR	27014	DM74LS173N OR J
U3645	156-0925-00	B010100	B020499	MICROCIRCUIT,DI:DUAL 2 WIDE 2INP	02735	CD4085BF
U3645	156-0925-01	B020500		MICROCIRCUIT,DI:DUAL 2 WIDE 2 INP	07263	34085DC
U3650	156-0578-00			MICROCIRCUIT,DI:DUAL 1 SHOT MULTIVIBRATOR	80009	156-0578-00
U3655	156-0366-00			MICROCIRCUIT,DI:DUAL D-TYPE F-F	80009	156-0366-00
U3730	156-0951-00			MICROCIRCUIT,DI:QUAD D RGSTR	27014	DM74LS173N OR J
VR482	152-0195-00			SEMICONV DEVICE:ZENER,0.4W,5.1V,5%	04713	SZ11755
VR500	152-0171-00			SEMICONV DEVICE:ZENER,0.5W,11.7V,5%	80009	152-0171-00
VR548	152-0278-00			SEMICONV DEVICE:ZENER,0.4W,3V,5%	04713	SZG35009K20
VR946	152-0123-00			SEMICONV DEVICE:ZENER,0.5W,9V,5%	04713	SZ11530RL
VR961	152-0123-00			SEMICONV DEVICE:ZENER,0.5W,9V,5%	04713	SZ11530RL
VR1032	152-0508-00			SEMICONV DEVICE:ZENER,0.4W,12.6V,5%	80009	152-0508-00
VR1136	152-0456-00			SEMICONV DEVICE:ZENER,0.4W,6.2V,5%	04713	1N827
VR1211	152-0395-00			SEMICONV DEVICE:ZENER,0.4W,4.3V,5%	14552	TD332317
VR1212	152-0395-00			SEMICONV DEVICE:ZENER,0.4W,4.3V,5%	14552	TD332317
VR1232	152-0456-00			SEMICONV DEVICE:ZENER,0.4W,6.2V,5%	04713	1N827
VR1234	152-0124-00			SEMICONV DEVICE:ZENER,0.5W,9V,5%	80009	152-0124-00
VR1438	152-0168-00			SEMICONV DEVICE:ZENER,0.4W,12V,5%	04713	SZG35009K4
VR1561	152-0306-00			SEMICONV DEVICE:ZENER,0.4W,9.1V,5%	15238	Z5409
VR1645	152-0306-00			SEMICONV DEVICE:ZENER,0.4W,9.1V,5%	15238	Z5409
VR1973	152-0304-00			SEMICONV DEVICE:ZENER,0.4W,20V,5%	15238	Z5411
VR2067	152-0291-00			SEMICONV DEVICE:ZENER,1W,20V,5%	04713	1N3027B
VR2199	152-0150-00			SEMICONV DEVICE:ZENER,0.75W,5% 51V	04713	1N3037B
VR2273	152-0280-00			SEMICONV DEVICE:ZENER,0.4W,6.2V,5%	80009	152-0280-00
VR2314	152-0227-00			SEMICONV DEVICE:ZENER,0.4W,6.2V,5%	04713	SZ13903
VR2337	152-0174-00			SEMICONV DEVICE:ZENER,0.5W,9V,5%	80009	152-0174-00
VR3346	152-0481-00			SEMICONV DEVICE:ZENER,1W,5.1V,5%	80009	152-0481-00
VR3480	152-0456-00			SEMICONV DEVICE:ZENER,0.4W,6.2V,5%	04713	1N827
W245	175-1954-00			CABLE ASSY,RF:50 OHM COAX,17.0 L	80009	175-1954-00

Replaceable Electrical Parts—7L18 Service

Ckt No.	Tektronix Part No.	Serial/Model No. Eff	Dscont	Name & Description	Mfr Code	Mfr Part Number
W550	175-1964-00			CABLE ASSY,RF:50 OHM COAX,13.0 L	80009	175-1964-00
W1120	175-1963-00			CABLE ASSY,RF:50 OHM COAX,21.0 L	80009	175-1963-00
W1180	175-1955-00			CABLE ASSY,RF:50 OHM COAX,28.0 L	80009	175-1955-00
W1389	175-1960-00			CABLE ASSY,RF:50 OHM COAX,19.5 L	80009	175-1960-00
W2484	175-1962-00			CABLE ASSY,RF:50 OHM COAX,7.5 L	80009	175-1962-00
W3175	175-1956-00			CABLE ASSY,RF:50 OHM COAX,10.0 L	80009	175-1956-00
W3180	175-2036-00			CABLE ASSY,RF:50 OHM COAX,10.0 L	80009	175-2036-00
W3235	175-1957-00			CABLE ASSY,RF:50 OHM COAX,14.0 L	80009	175-1957-00
W3245	175-2037-00			CABLE ASSY,RF:50 OHM COAX,12.5 L	80009	175-2037-00
W3420	175-1958-00			CABLE ASSY,RF:50 OHM COAX,9.0 L	80009	175-1958-00
Y960	158-0131-00			XTAL UNIT,QTZ:15.8MHZ 0.001% SERIES	80009	158-0131-00
Y962	158-0132-00			XTAL UNIT,QTZ:15.808MHZ 0.001% SERIES	80009	158-0132-00
Y964	158-0133-00			XTAL UNIT,QTZ:15.816MHZ 0.001% SERIES	80009	158-0133-00
Y966	158-0134-00			XTAL UNIT,QTZ:15.824MHZ 0.001% SERIES	80009	158-0134-00
Y1080	-----			(FURNISHED AS A UNIT WITH A940A5)		
Y2375	158-0137-00			XTAL UNIT,QTZ:125MHZ,0.01%,SERIES	71034	BK3-1B

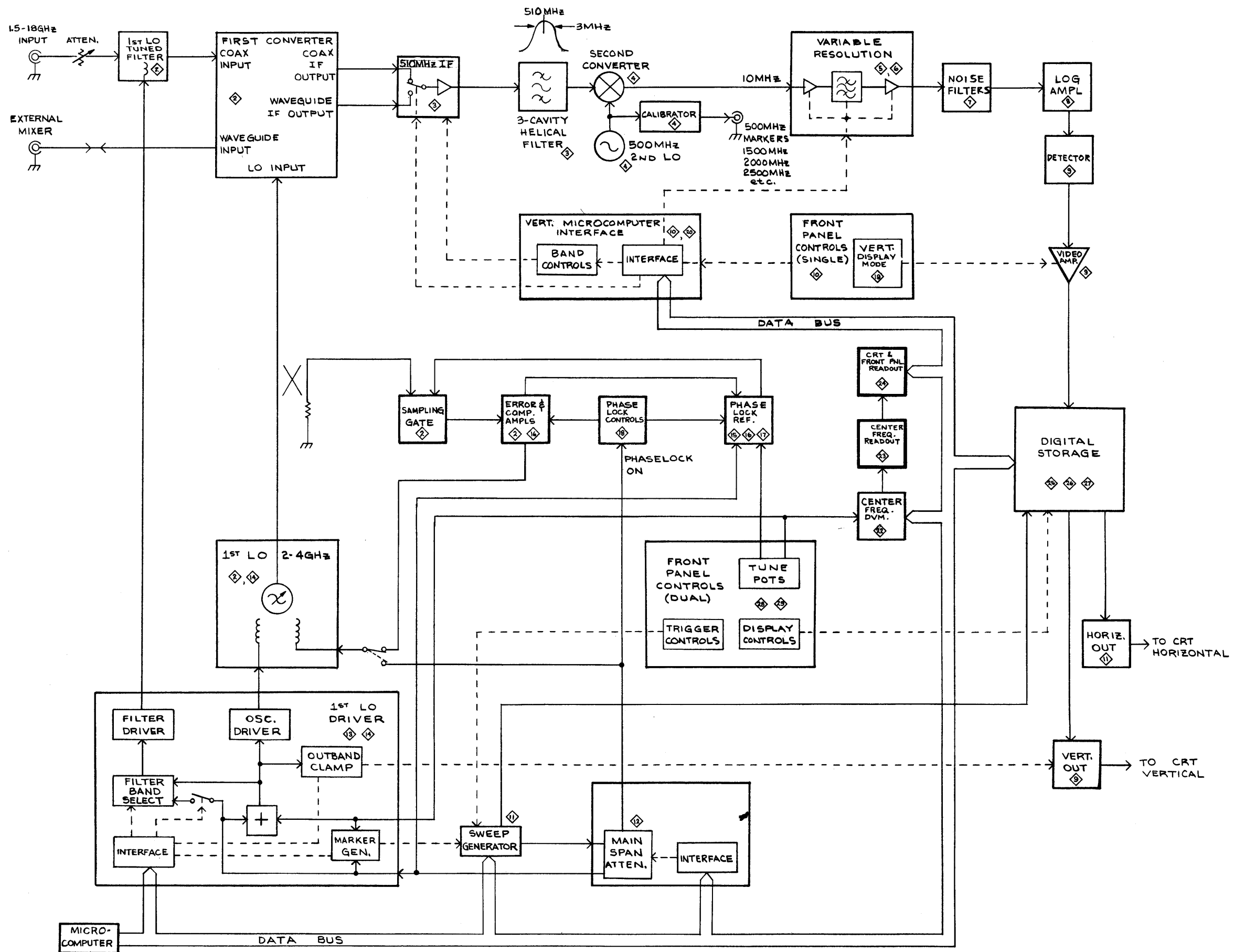

7L18 SIMPLIFIED BLOCK DIAGRAM

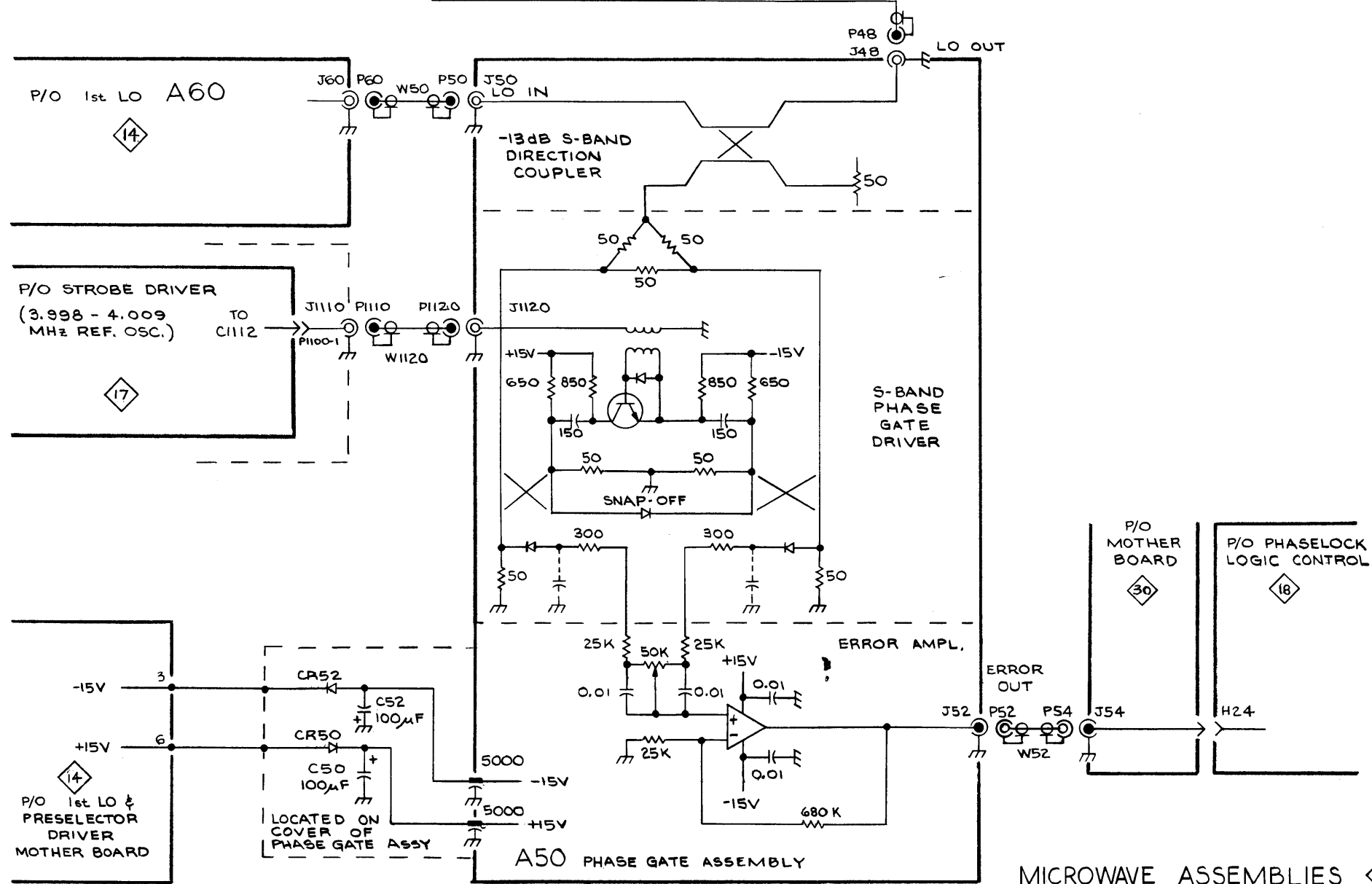
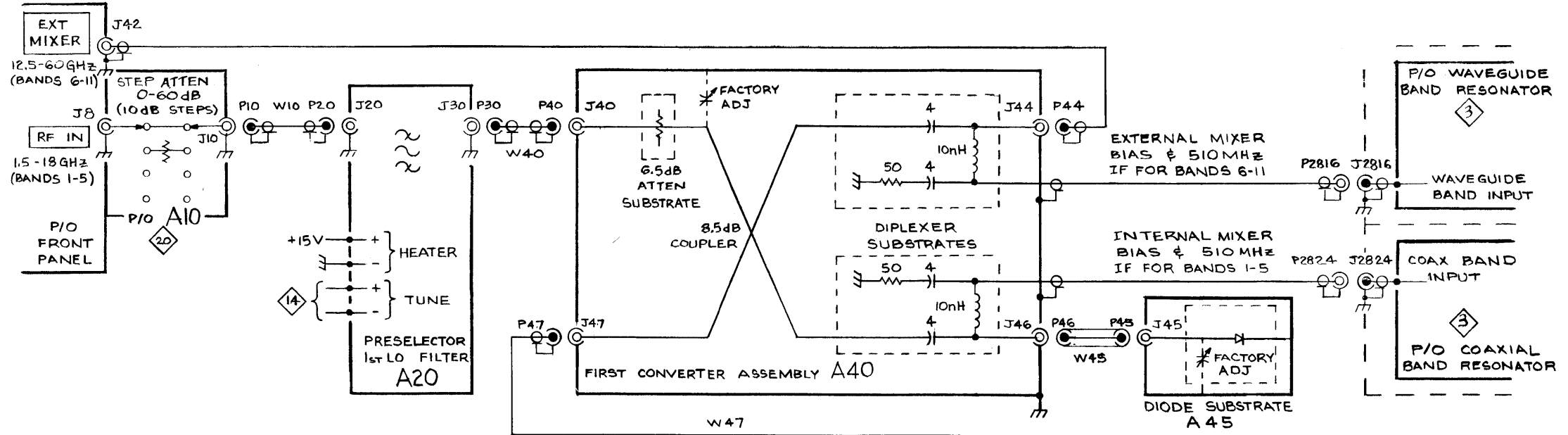
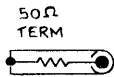

7L18

MICROWAVE ASSEMBLIES 2

MICROWAVE ASSEMBLIES

2

510 MHz IF

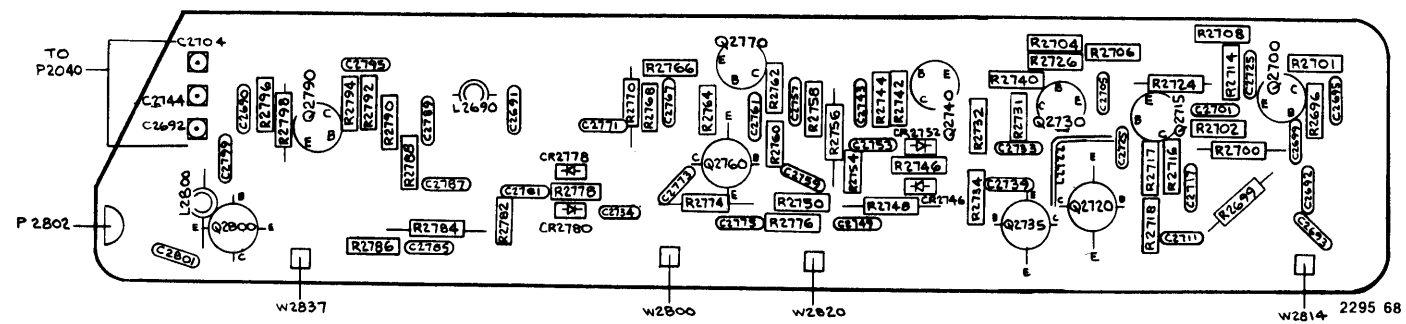

7L18 H-5038-01 A2690A1 510MHz AMPLIFIER

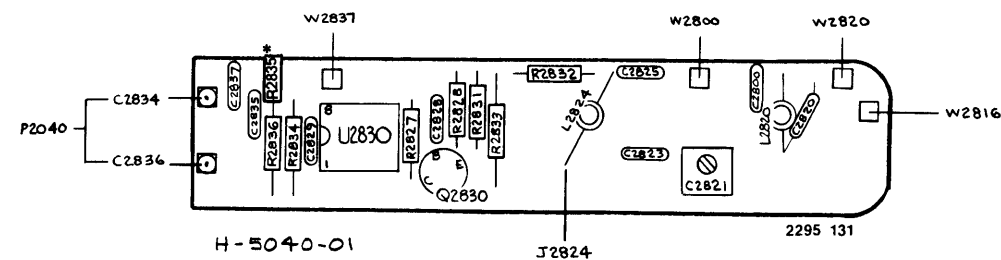

H-5040-01 J2824 7L18 A2690A3 COAXIAL BAND RESONATOR

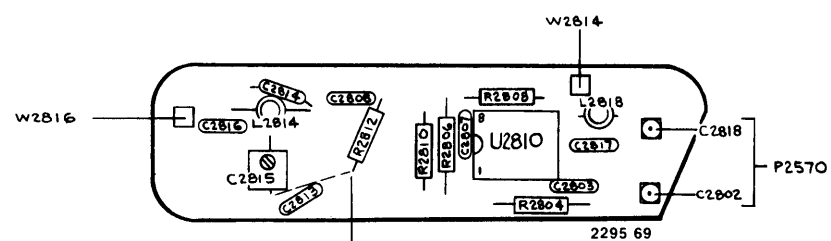

H-5039-01 J2816 7L18 A2690A2 WAVEGUIDE BAND RESONATOR

*See Parts List for serial number ranges.

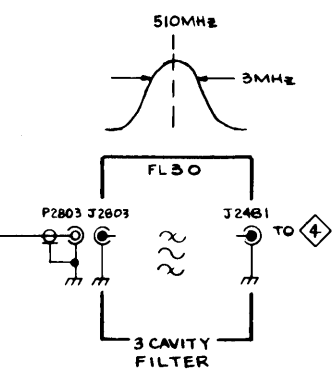
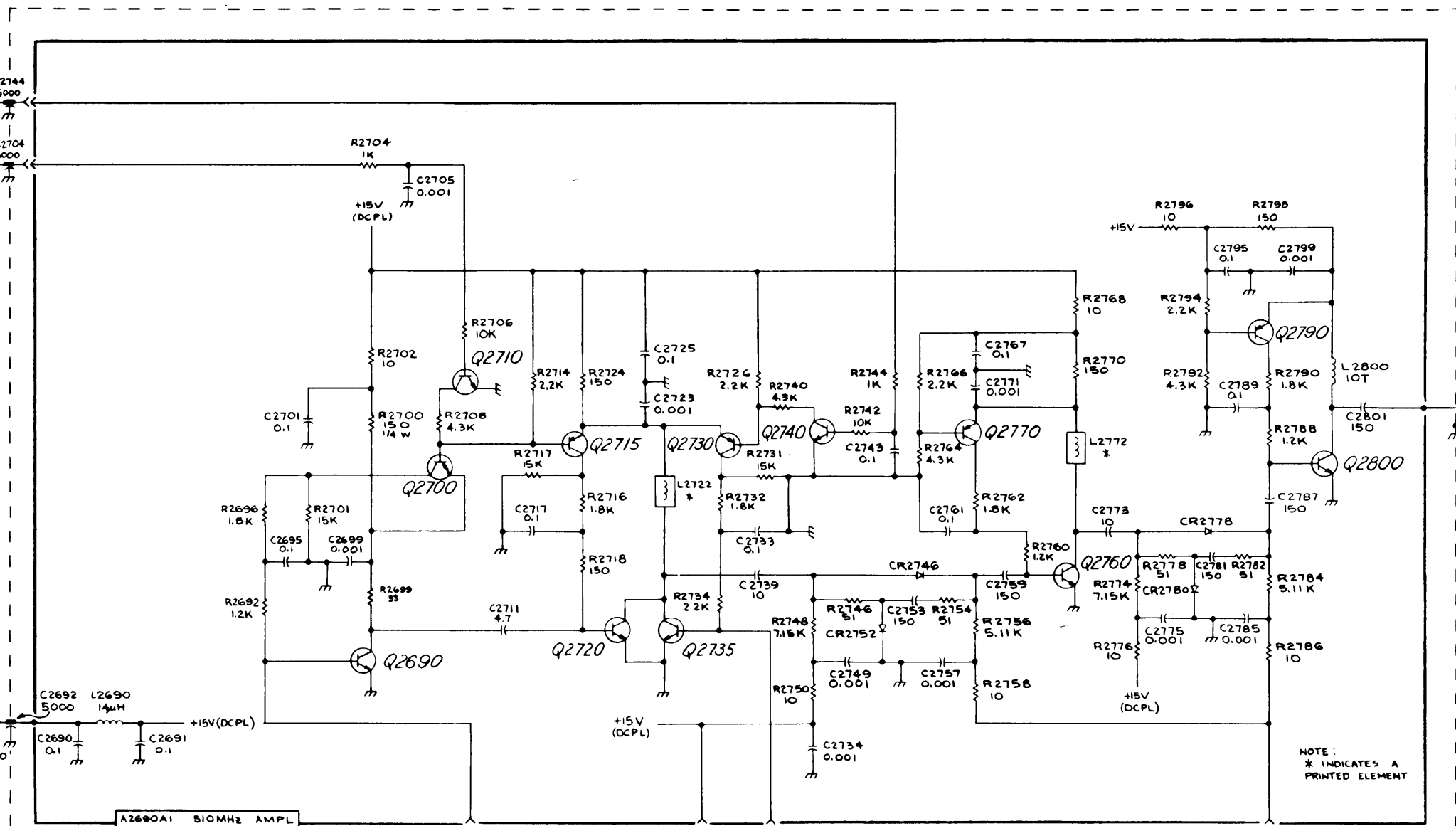
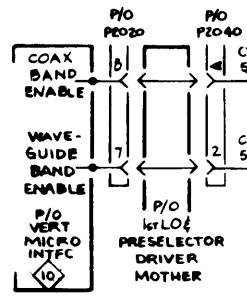

SEE PARTS LIST FOR EARLIER VALUES AND SERIAL NUMBER RANGES OF PARTS OUTLINED OR DEPICTED IN GREY.

NOTE: * INDICATES A PRINTED ELEMENT

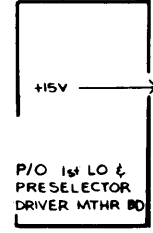

A2690A1 510MHz AMPL

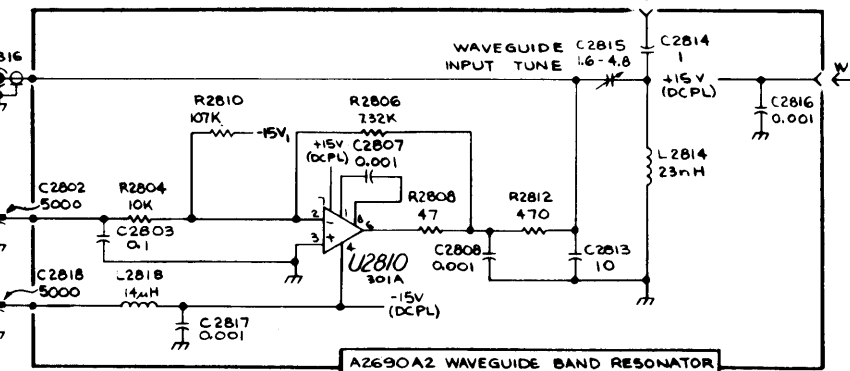
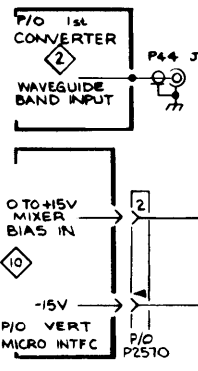

A2690A2 WAVEGUIDE BAND RESONATOR

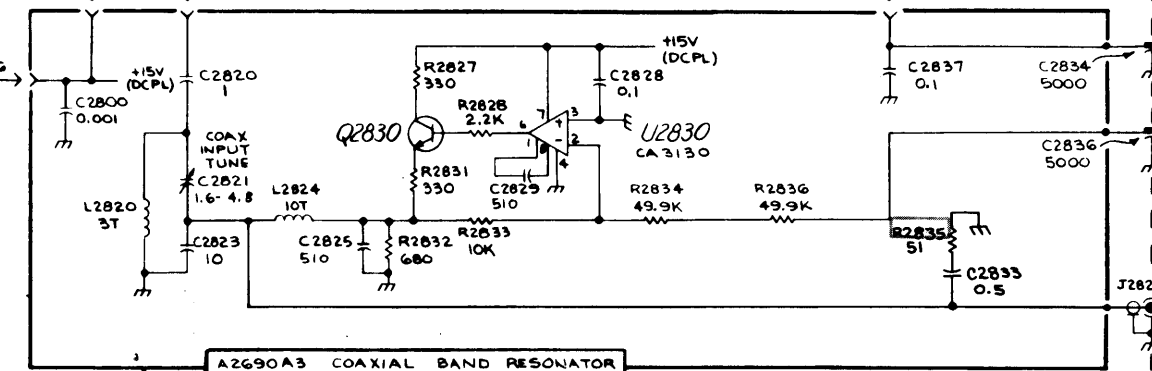

A2690A3 COAXIAL BAND RESONATOR

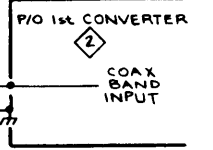
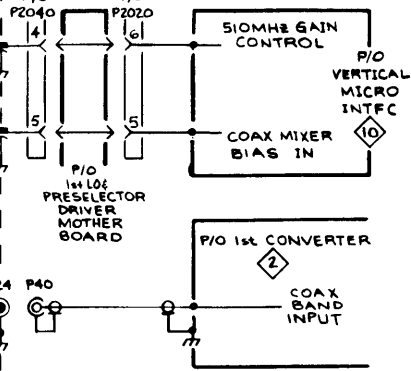

A2690 510MHz IF AMPLIFIER

7L18

2295-70

510 MHz IF AMPLIFIER

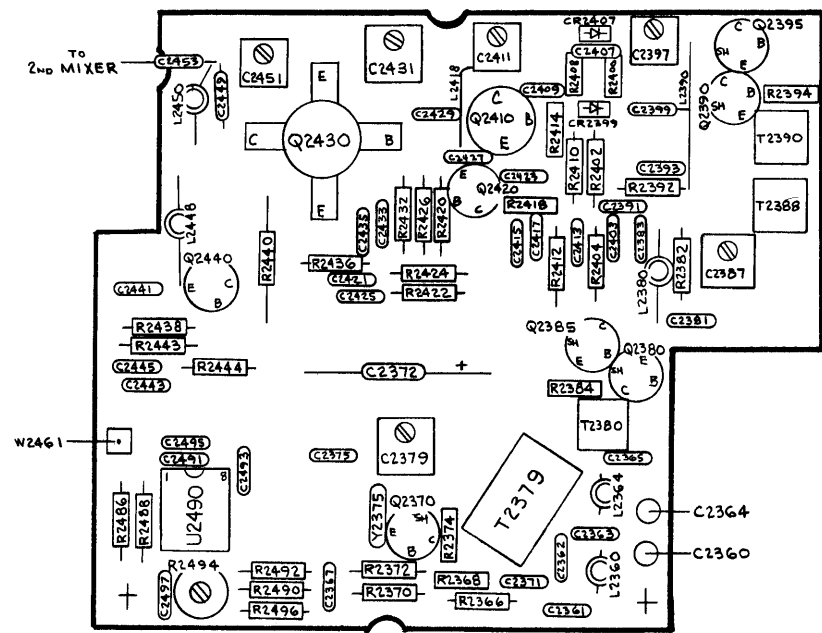

7L18 H-5033-02 A2360A1 500MHz LO

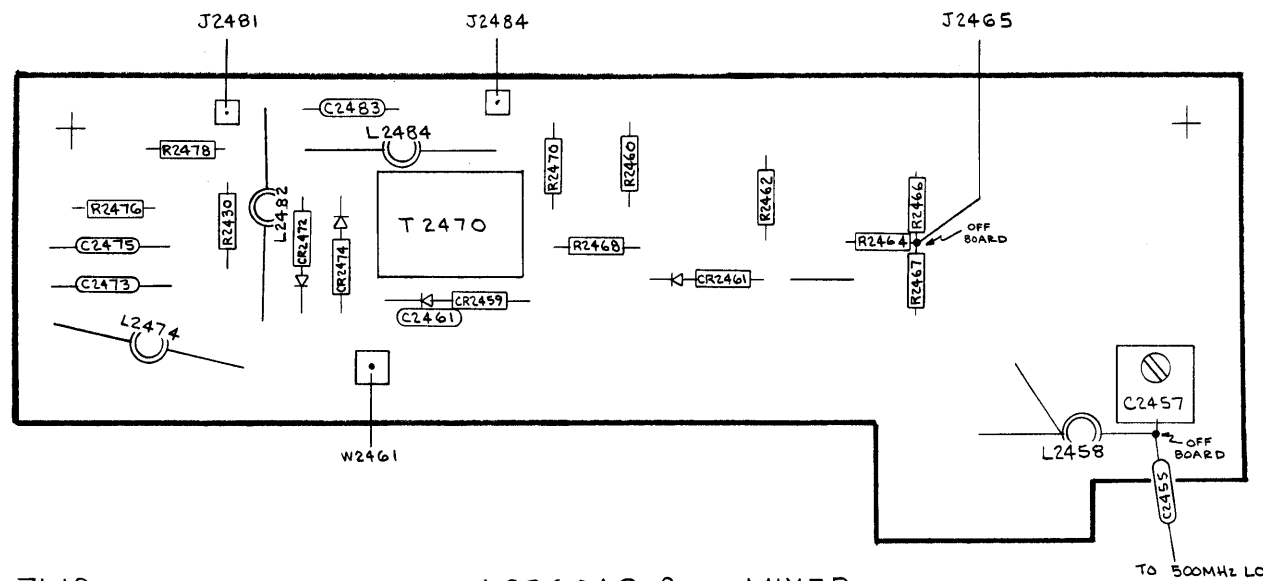

7L18 H-5320-01 A2360A2 2ND MIXER

500 MHz LO/2ND MIXER

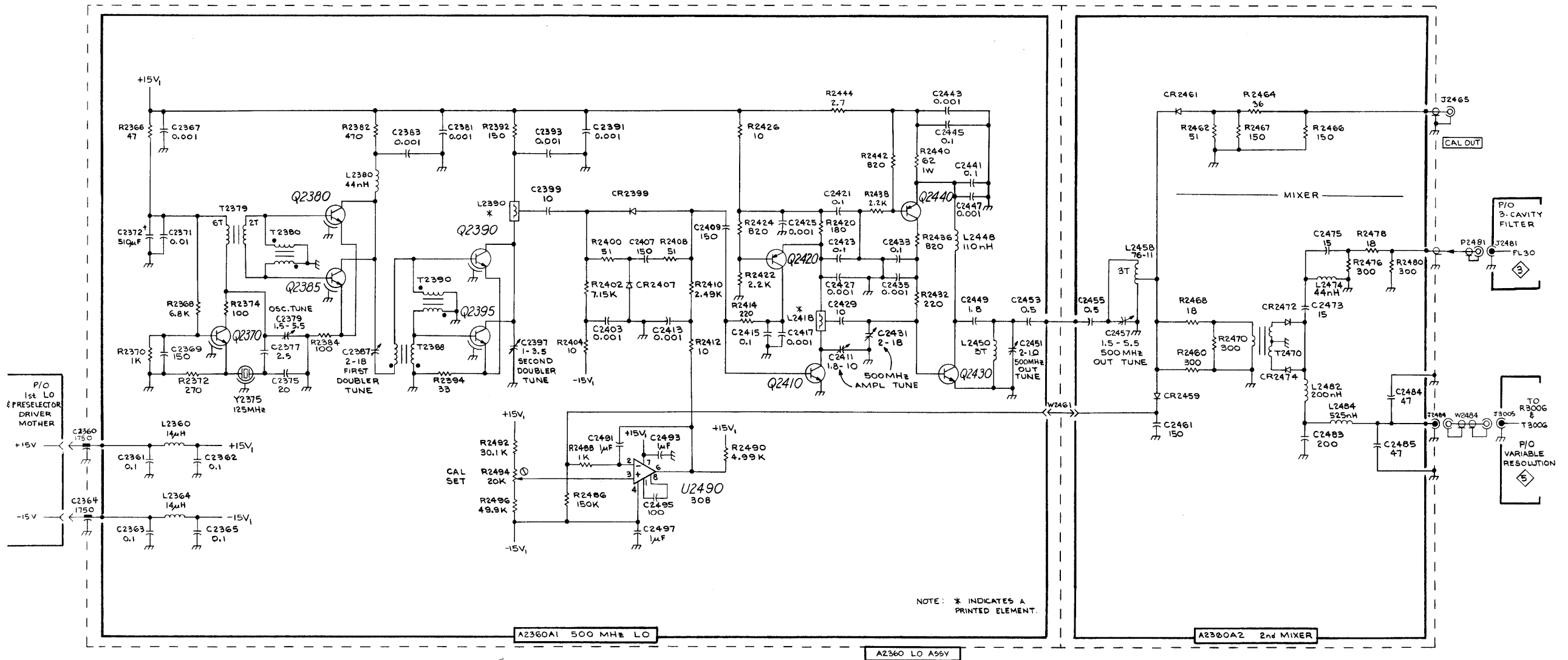

7L18

500MHz LO CHAIN & MIXER

500 MHz LO CHAIN & MIXER

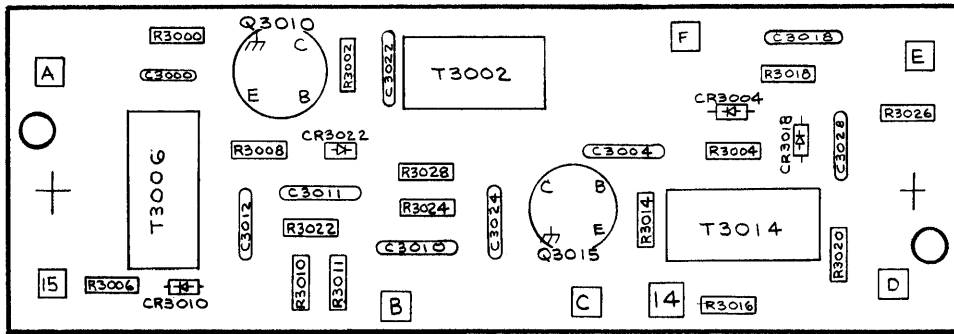

7L18 A3000A1 VARIABLE RESOLUTION INPUT
H-5204-01

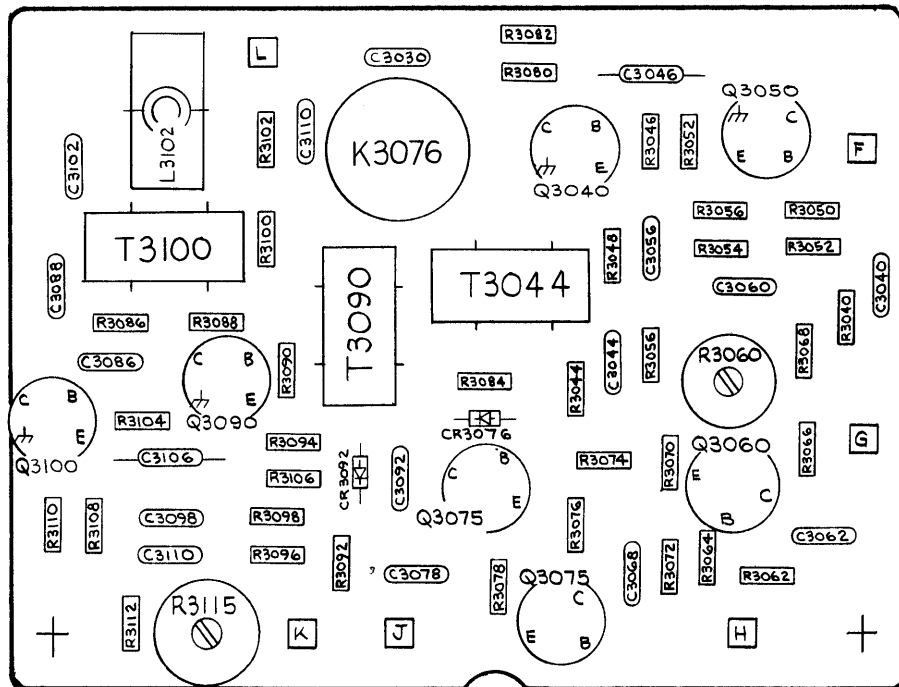

7L18 A3000A2 VARIABLE RESOLUTION PRE-AMPLIFIER
H-5205-00

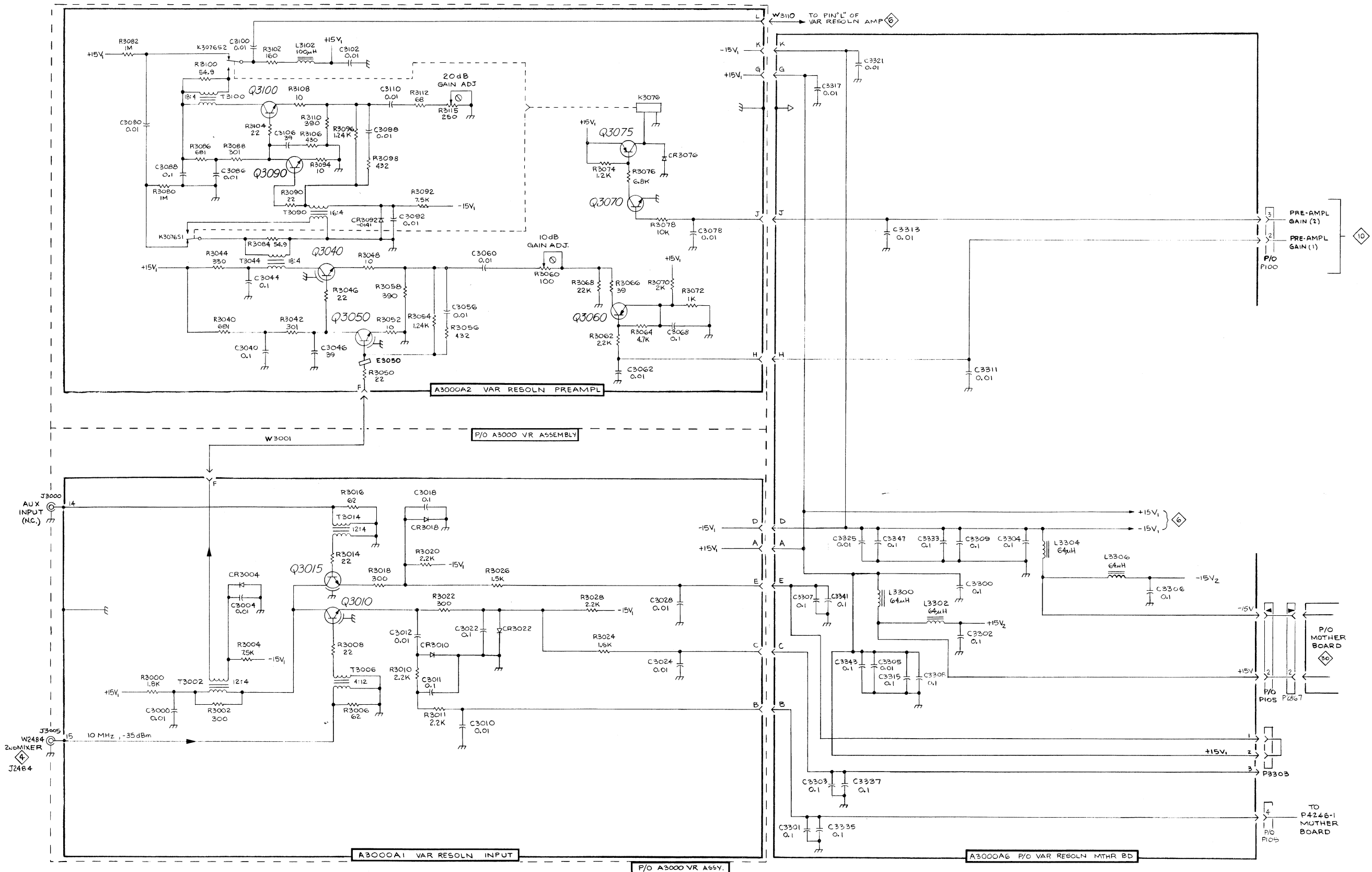

7L18

A3000 VARIABLE RESOLUTION 5

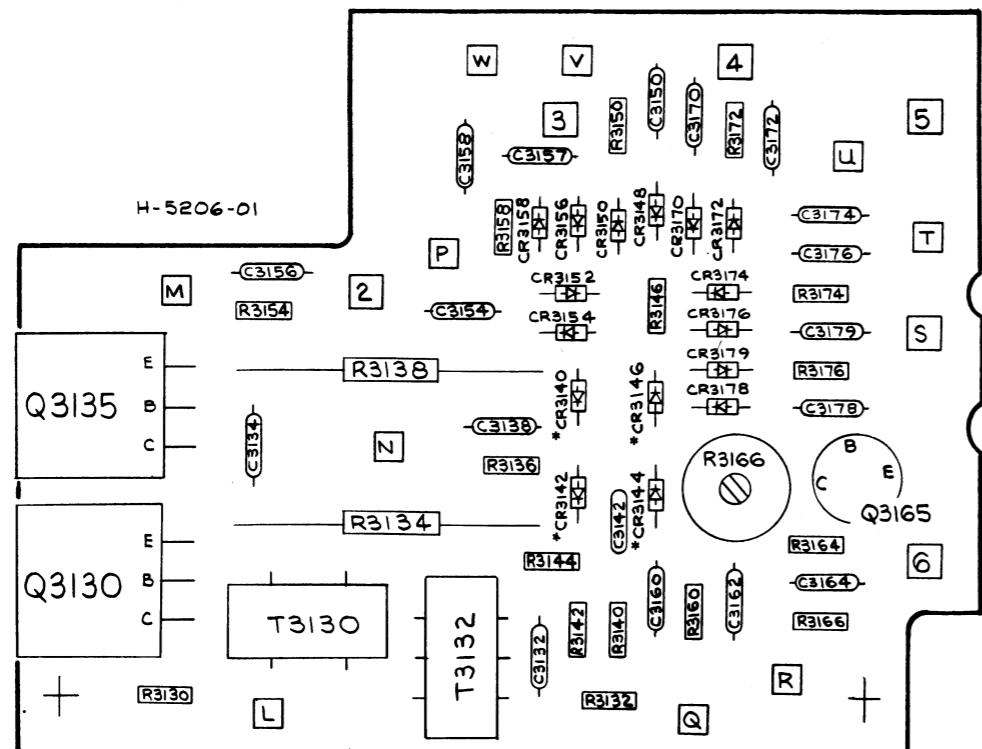

7L18 A3000A3 VARIABLE RESOLUTION AMPLIFIER 2295 77

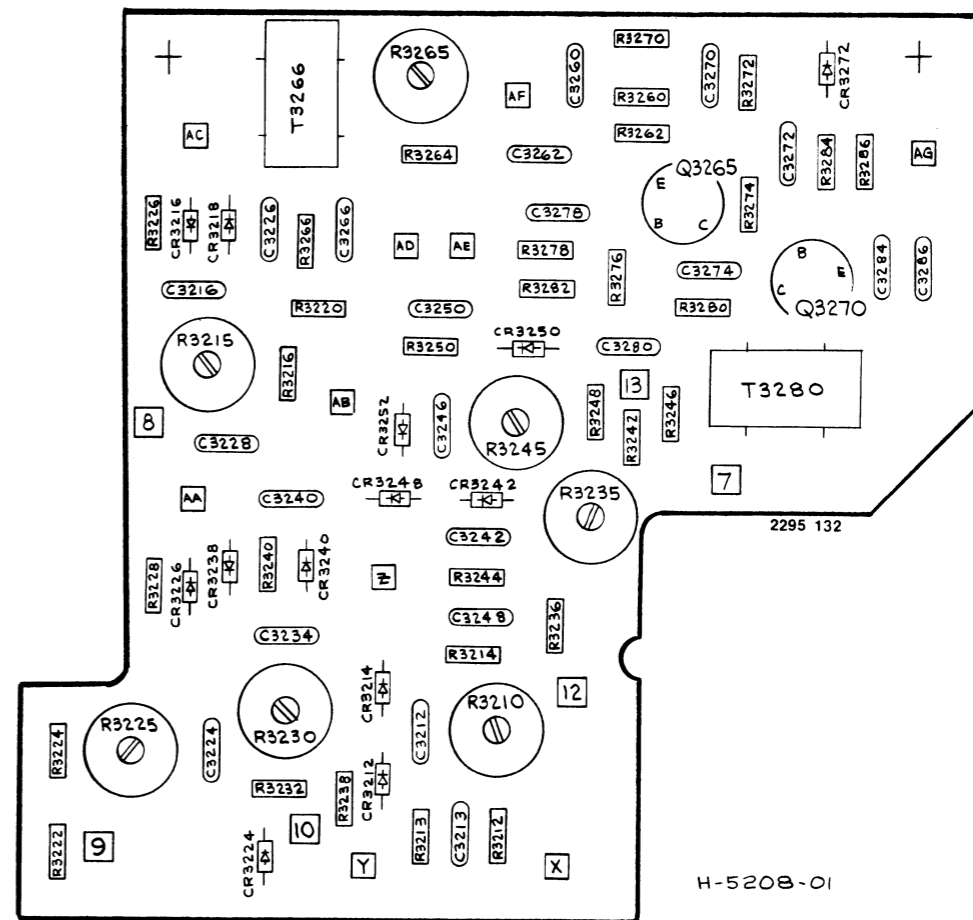

7L18 A3000A5 POST VARIABLE RESOLUTION AMPLIFIER 2295 132

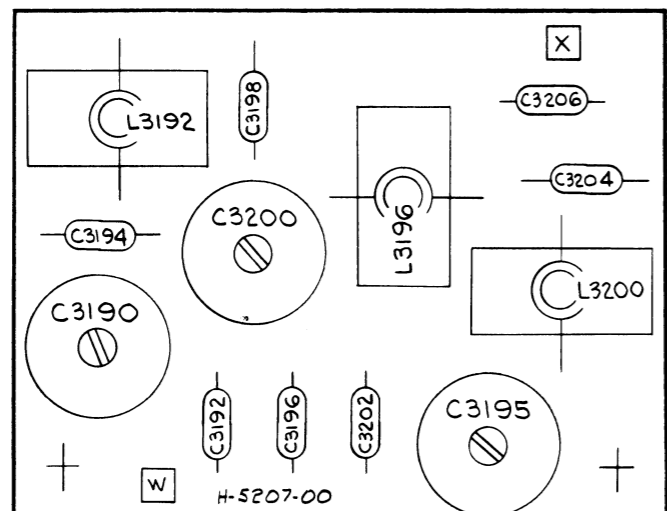

7L18 A3000A4 300kHz FILTER 2295 78

*See Parts List for
serial number ranges.

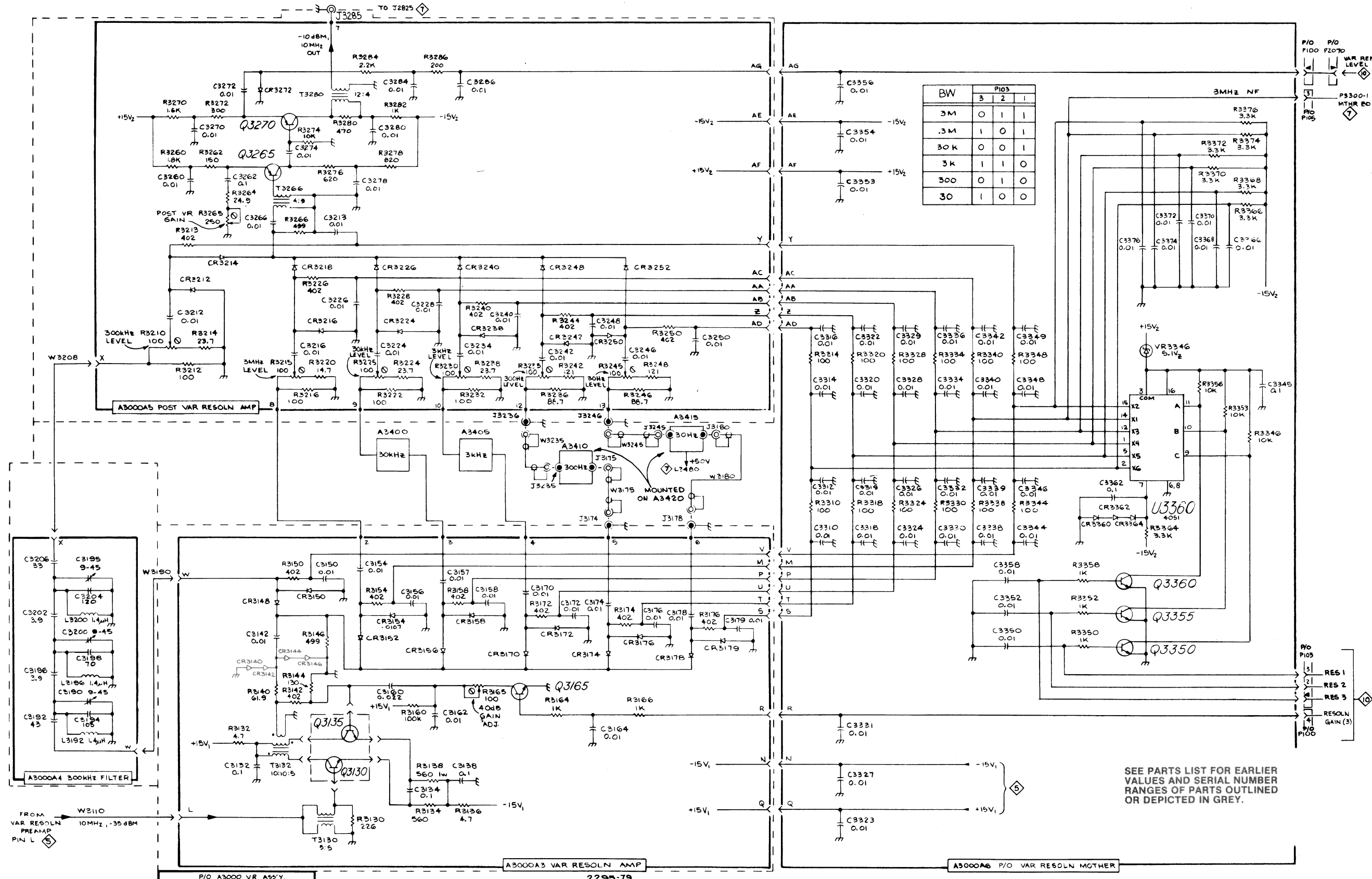

BW	P103		
	3	2	1
3M	0	1	1
.3M	1	0	1
30K	0	0	1
300	0	1	0
30	1	0	0

SEE PARTS LIST FOR EARLIER VALUES AND SERIAL NUMBER RANGES OF PARTS OUTLINED OR DEPICTED IN GREY.

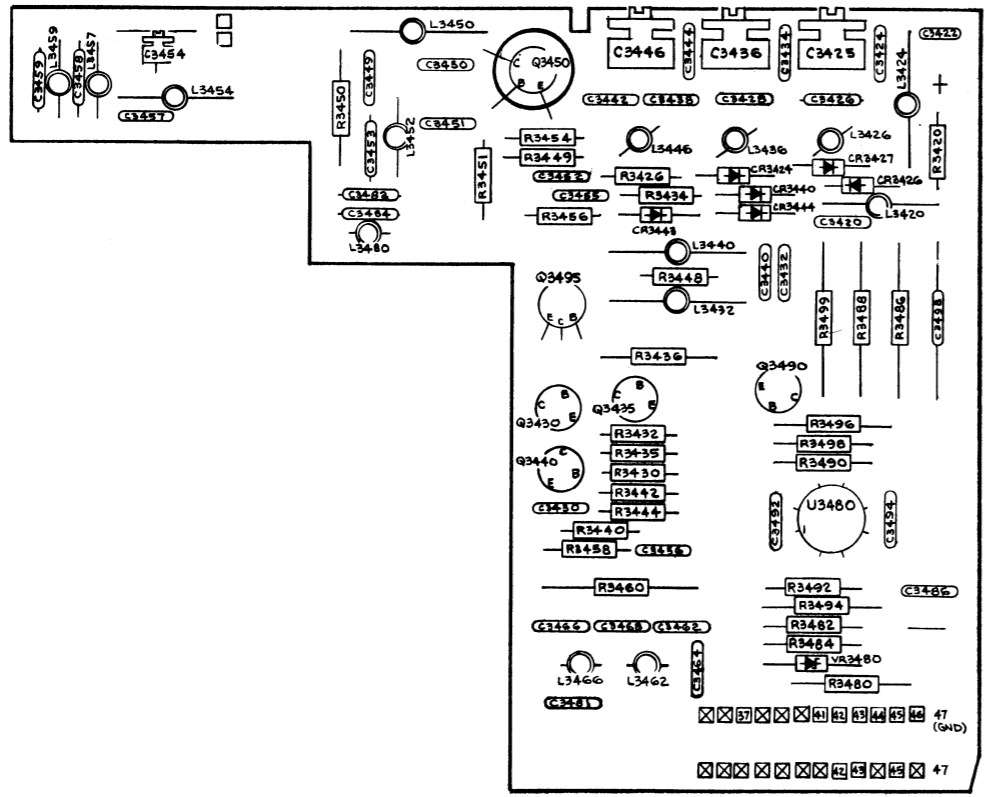

7L18 H-5012-02 A3420 VARIABLE RESOLUTION NOISE FILTER

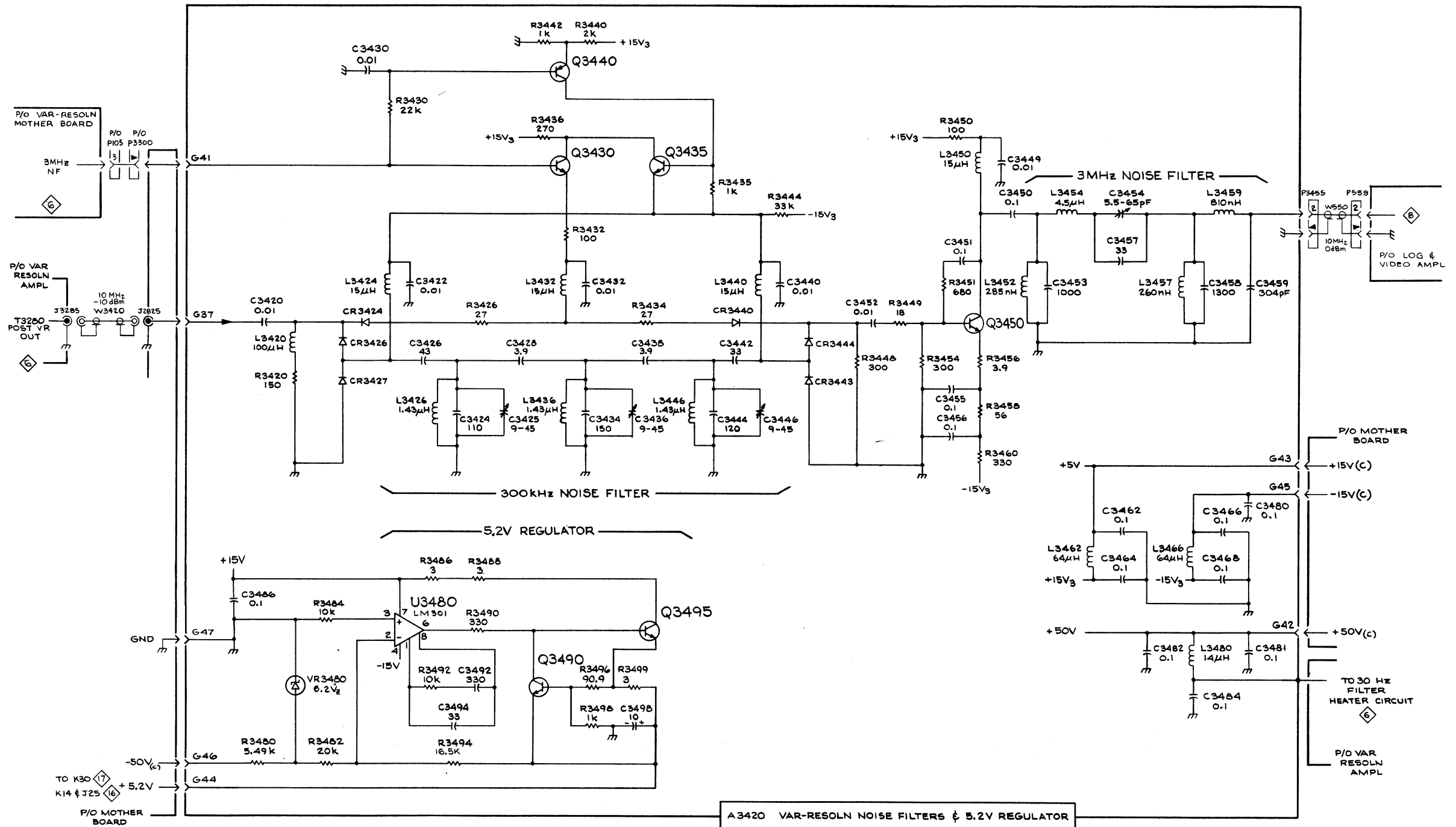

7L18

VAR-RESOLN NOISE FILTERS & 5.2V REGULATOR

VAR NOISE FILTERS & 5.2V REGULATOR

7

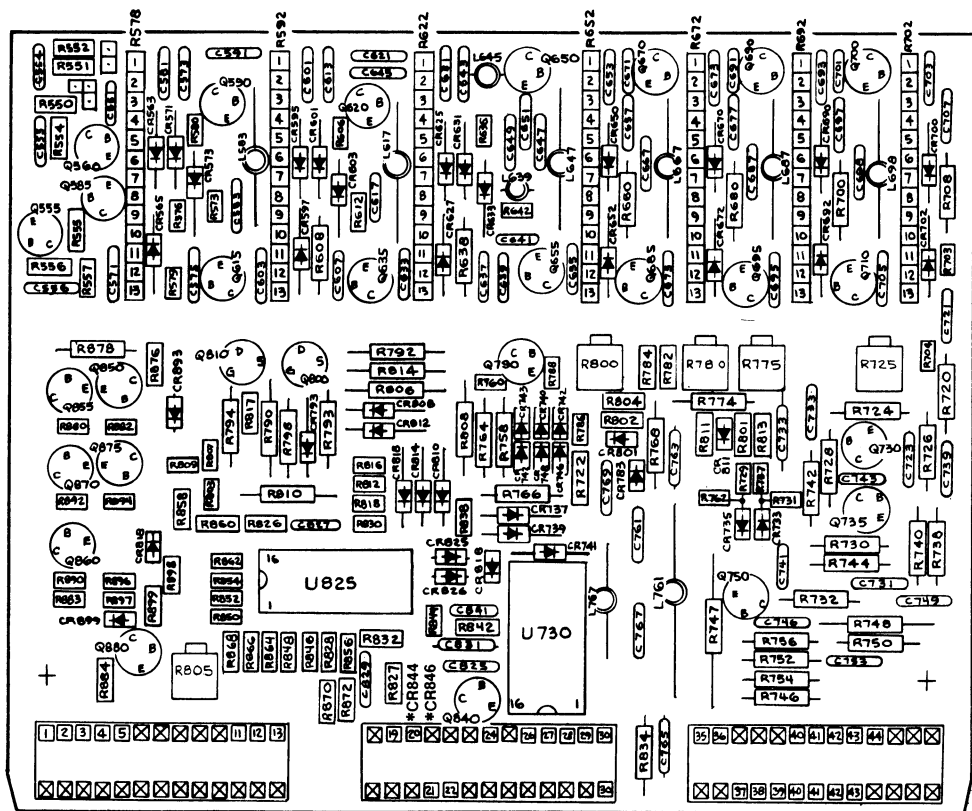

2295 82

7L18 H-5009-00 A550 LOG & VIDEO AMPLIFIER

*See Parts List for serial number ranges.

LOG AMPLIFIER

Measurements
in $\mu\text{P}/\mu\text{K}$

10db Logging

	Q700	Q690	Q670	Q650	Q620	Q590	Q710
Input	Base	Base	Base	Base	Base	Base	Coll.
0.6m	5.8	5.2	4.7	3.6	2.8	2.2	4.2
-10	5.1	4.5	3.9	2.8	2.2	1.4	3.8
-20	4.4	3.7	3.1	2.15	1.4	.8	3.2
-30	3.6	3.0	2.2	1.4	.8	.29	2.8
-40	2.8	2.2	1.4	.72	.25	.1	2.25
-50	2.0	1.4	.72	.25	.095	.03	1.75
-60	1.25	.7	.24	.09	.03	.007	1.7
-70	1.7	.25	.085	.03	.007	.007	1.65

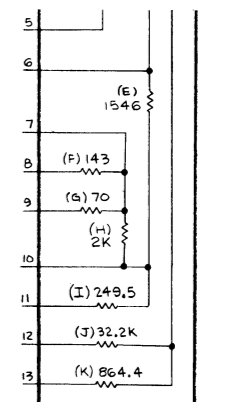
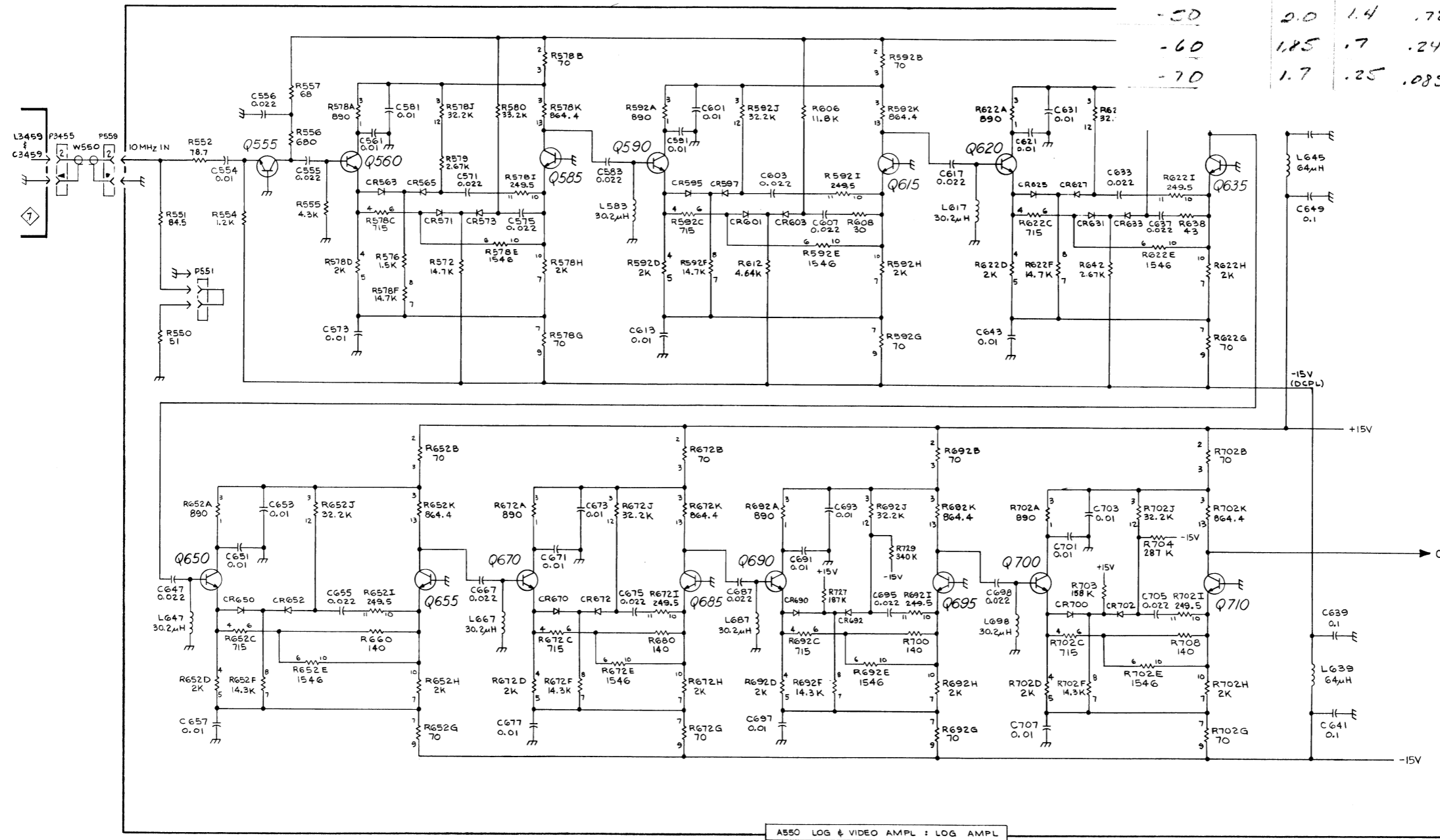

LOG AMPLIFIER ASSEMBLY
TYPICAL OF:
R578, R592, R622, R652,
R672, R692 & R702

A850 LOG & VIDEO AMPL : LOG AMPL

7L18

LOG & VIDEO AMPL : LOG AMPL

LOG AMPLIFIER

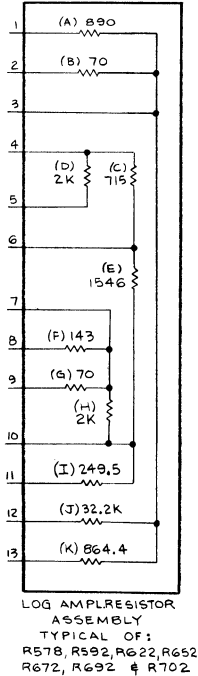
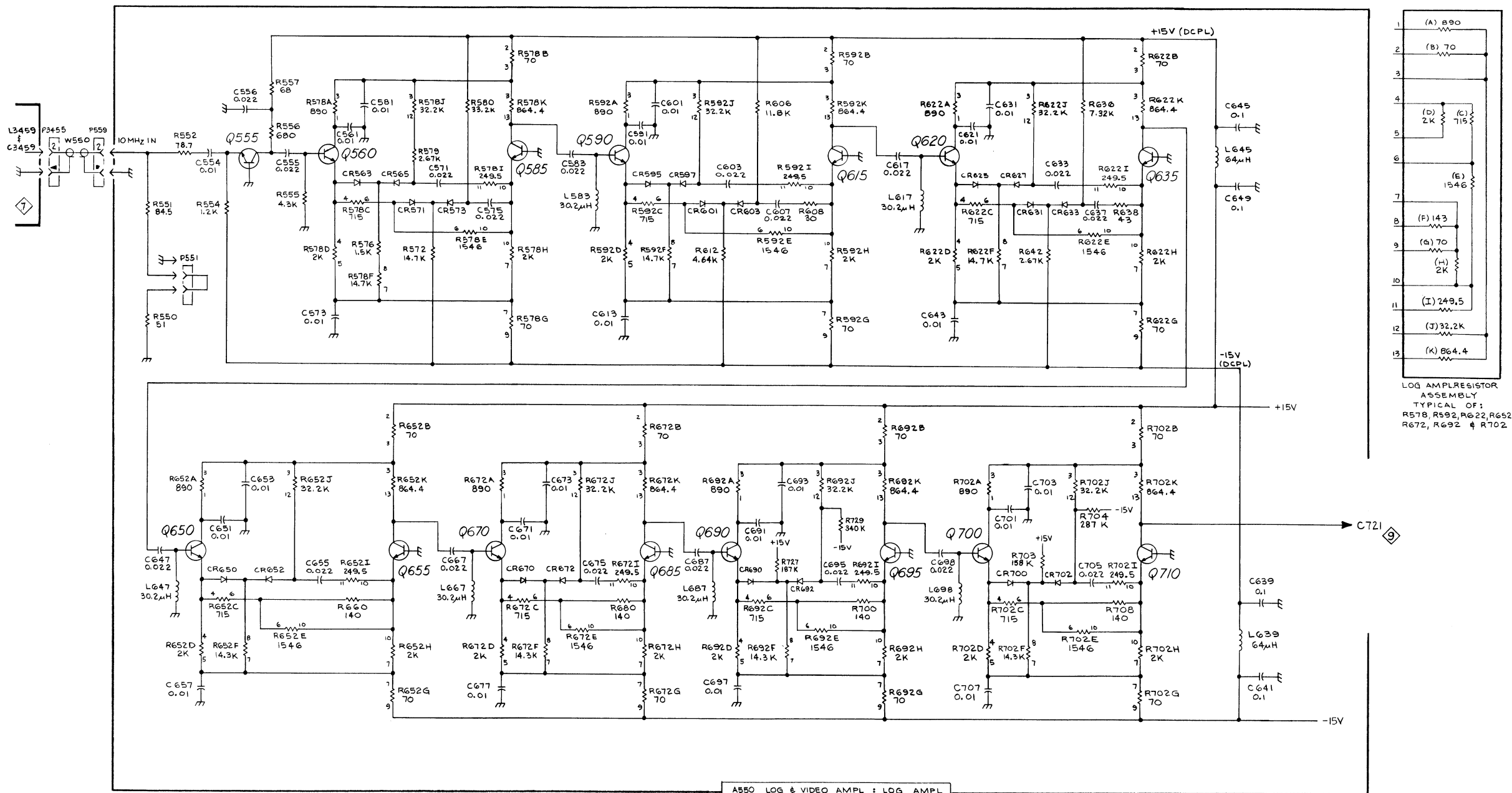

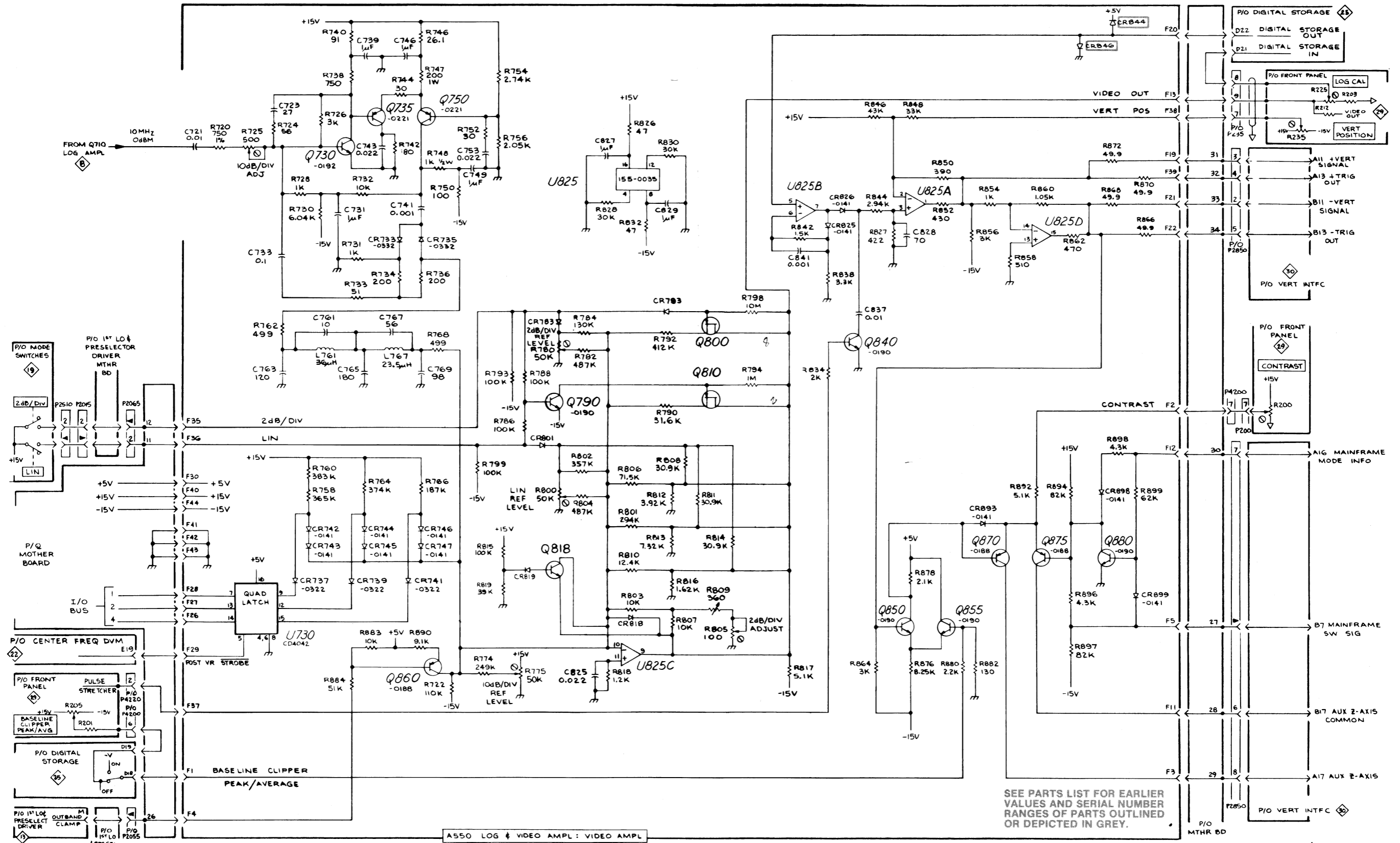

SEE PARTS LIST FOR EARLIER VALUES AND SERIAL NUMBER RANGES OF PARTS OUTLINED OR DEPICTED IN GREY.

A550 LOG & VIDEO AMPL : VIDEO AMPL

2295-84

LOG & VIDEO AMPL : VIDEO AMPL

7L18

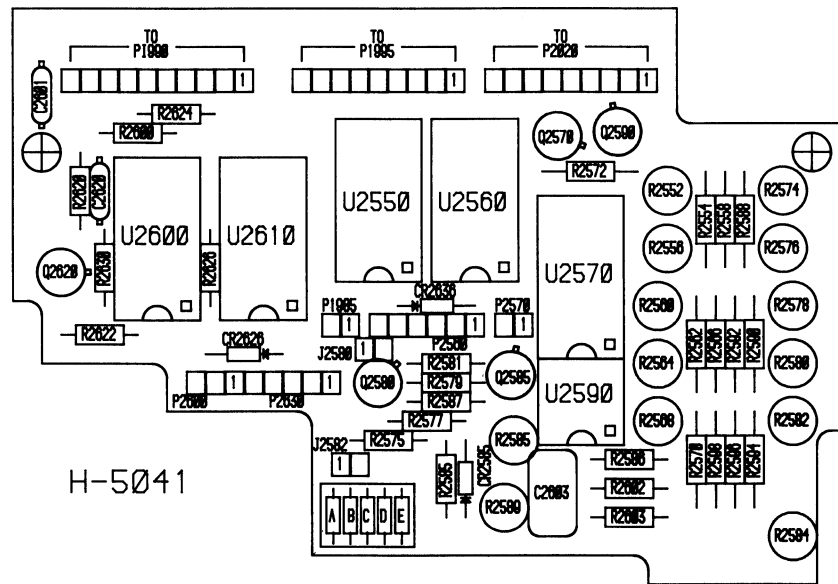

A2550 VERTICAL MICROCOMPUTER INTERFACE

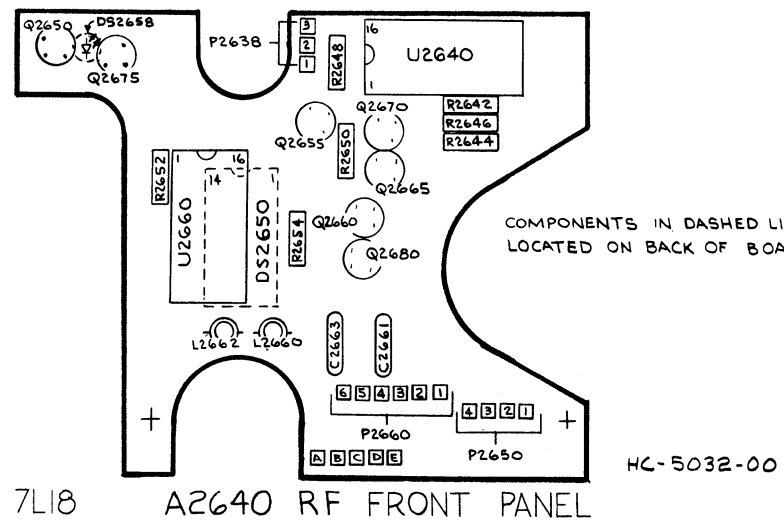

7L18 A2640 RF FRONT PANEL

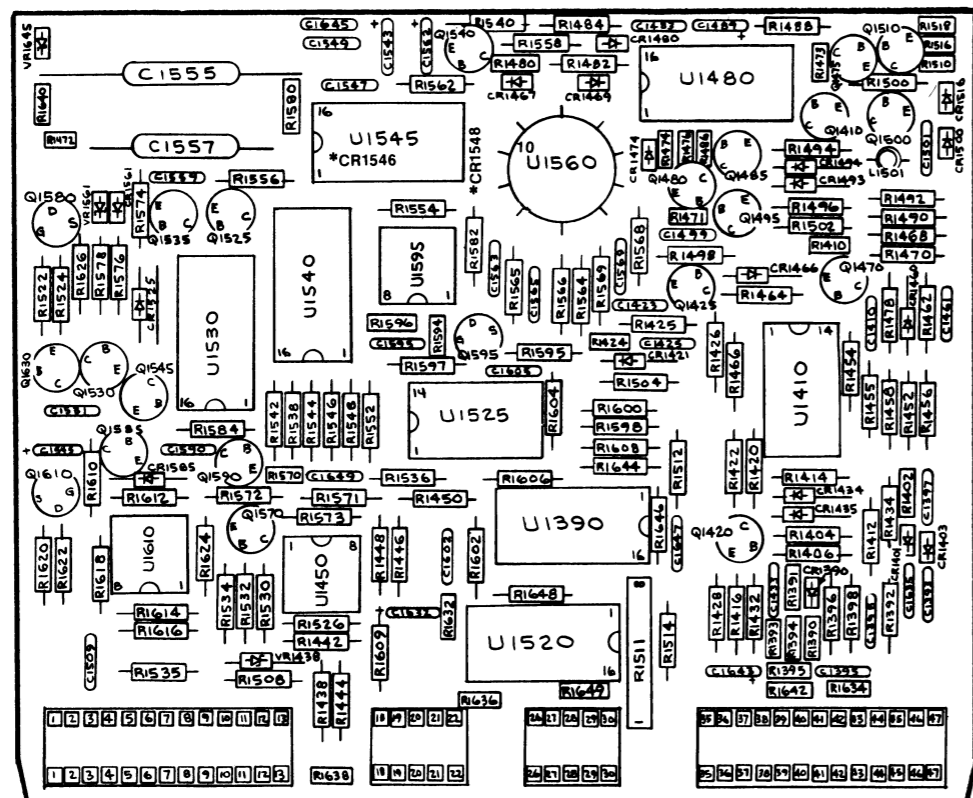

7L18 H-5022-01 A1390 HORIZONTAL SWEEP 2295 88

*See Parts List for serial number ranges.

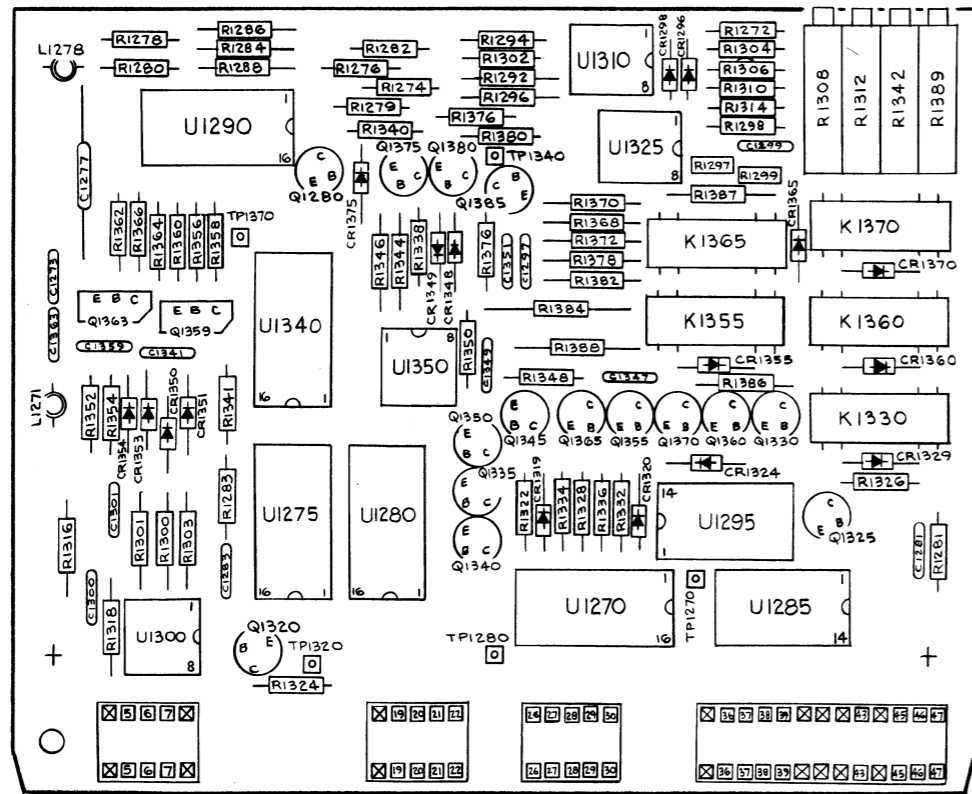

7L18

H-5021-02

AI270 SPAN ATTENUATOR

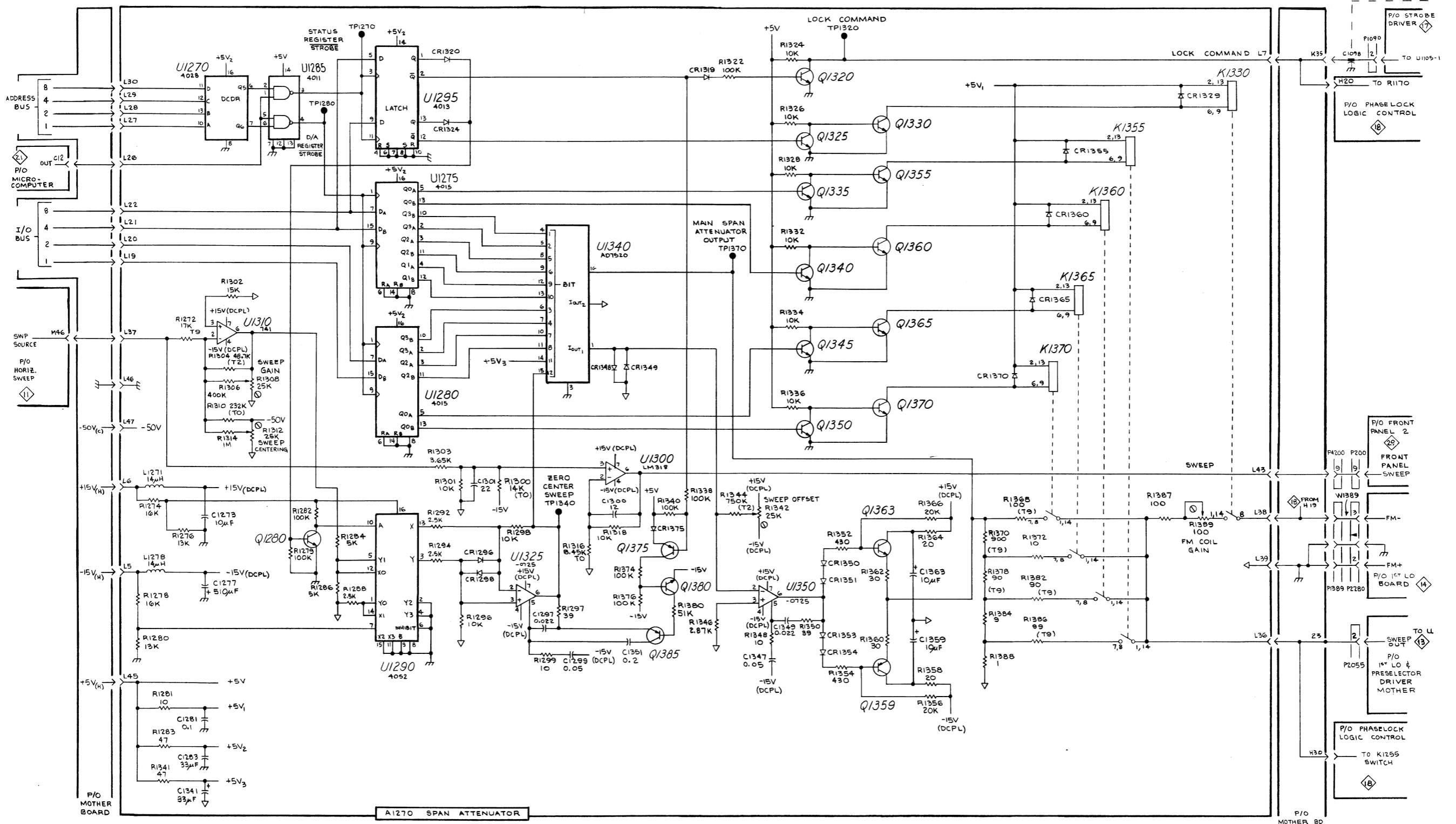

7L18

SPAN ATTENUATOR (2)

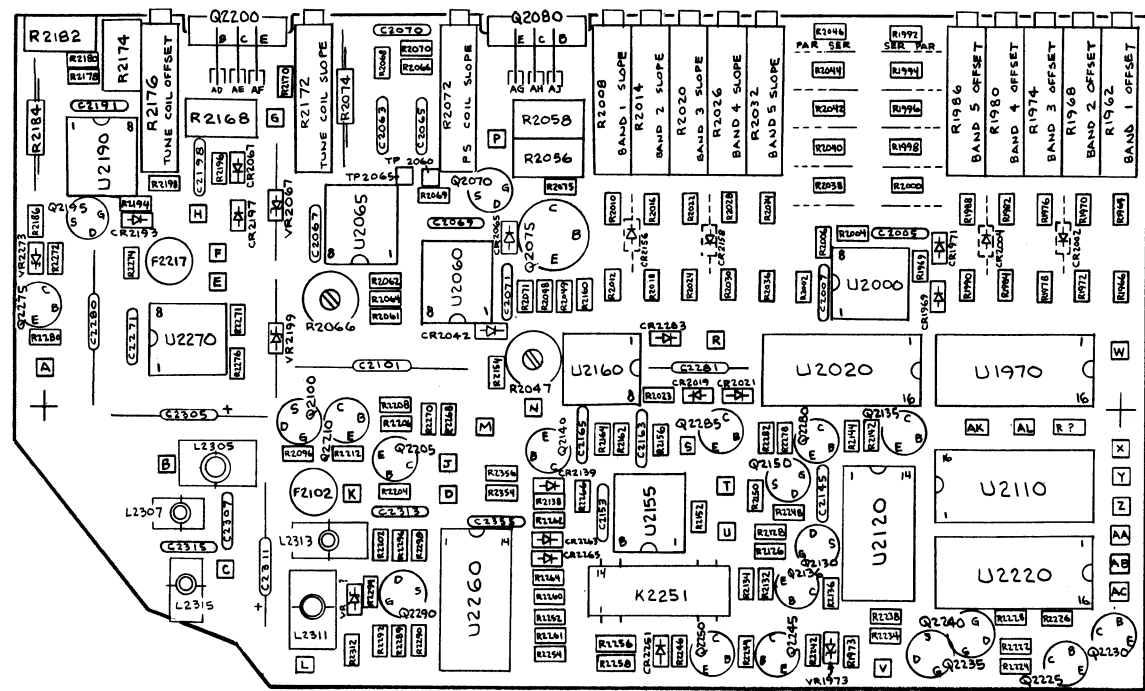

7L18 H-5032-01 A1962 1ST LO/PRESELECTOR DRIVER

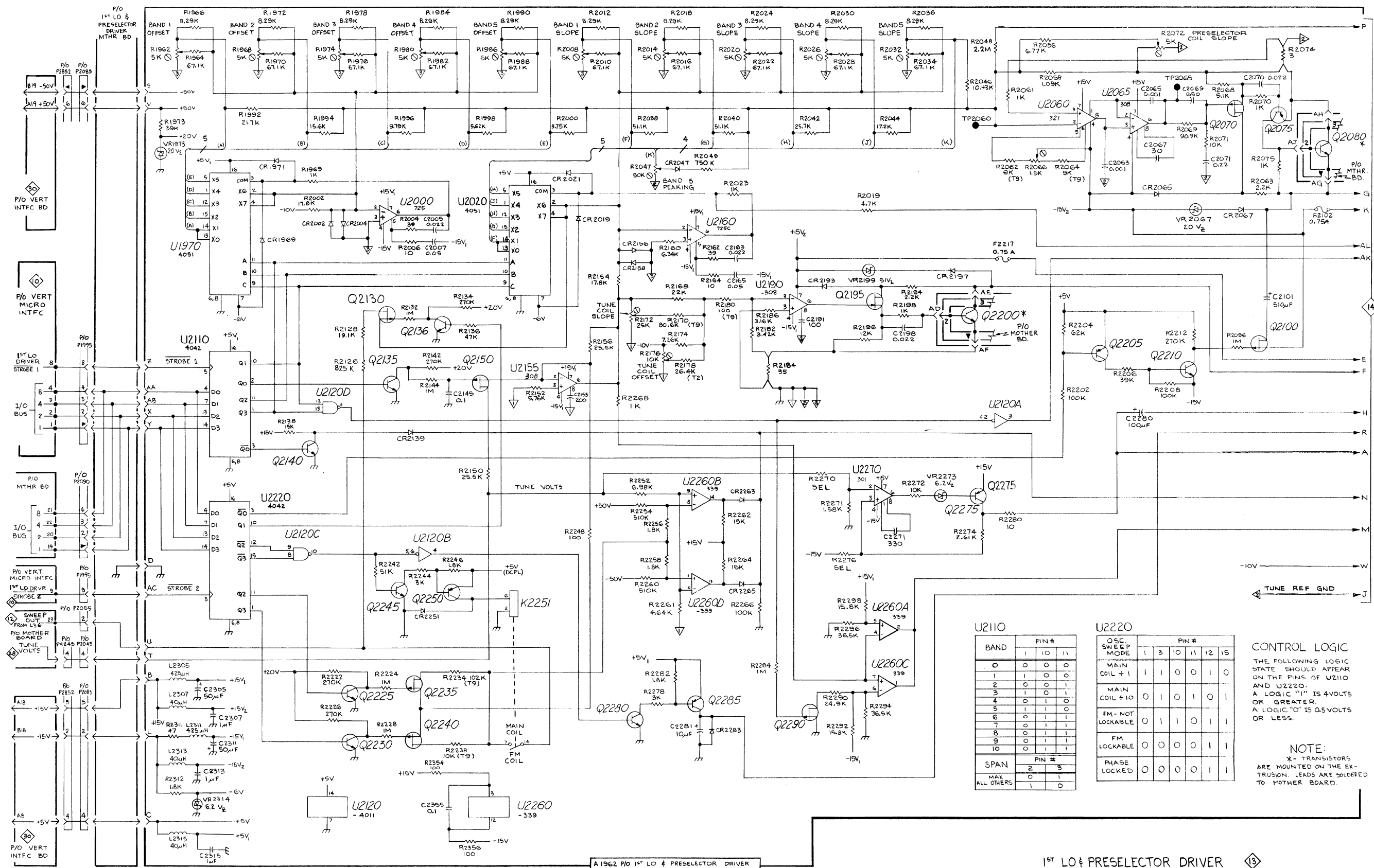

U2110

BAND	PIN #		
	1	10	11
0	0	0	0
1	1	0	0
2	0	0	1
3	1	0	1
4	0	1	0
5	1	1	0
6	0	1	1
7	0	1	1
8	0	1	1
9	0	1	1
10	0	1	1
SPAN	PIN #		
MAX	0	1	
ALL OTHERS	1	0	

U2220

OSC SWEEP MODE	PIN #				
	1	3	10	11	12
MAIN COIL + 1	1	1	0	0	1
MAIN COIL + 10	0	1	0	1	0
FM - NOT LOCKABLE	0	1	1	0	1
FM LOCKABLE	0	0	0	0	1
PHASE LOCKED	0	0	0	0	1

CONTROL LOGIC

THE FOLLOWING LOGIC STATE SHOULD APPEAR ON THE PINS OF U2110 AND U2220. A LOGIC "1" IS 4VOLTS OR GREATER. A LOGIC "0" IS 0.5VOLTS OR LESS.

NOTE:

*- TRANSISTORS ARE MOUNTED ON THE EXTENSION BOARD. LEADS ARE SOLDERED TO MOTHER BOARD.

A1962 P/O 1ST LO & PRESELECTOR DRIVER

1ST LO & PRESELECTOR DRIVER

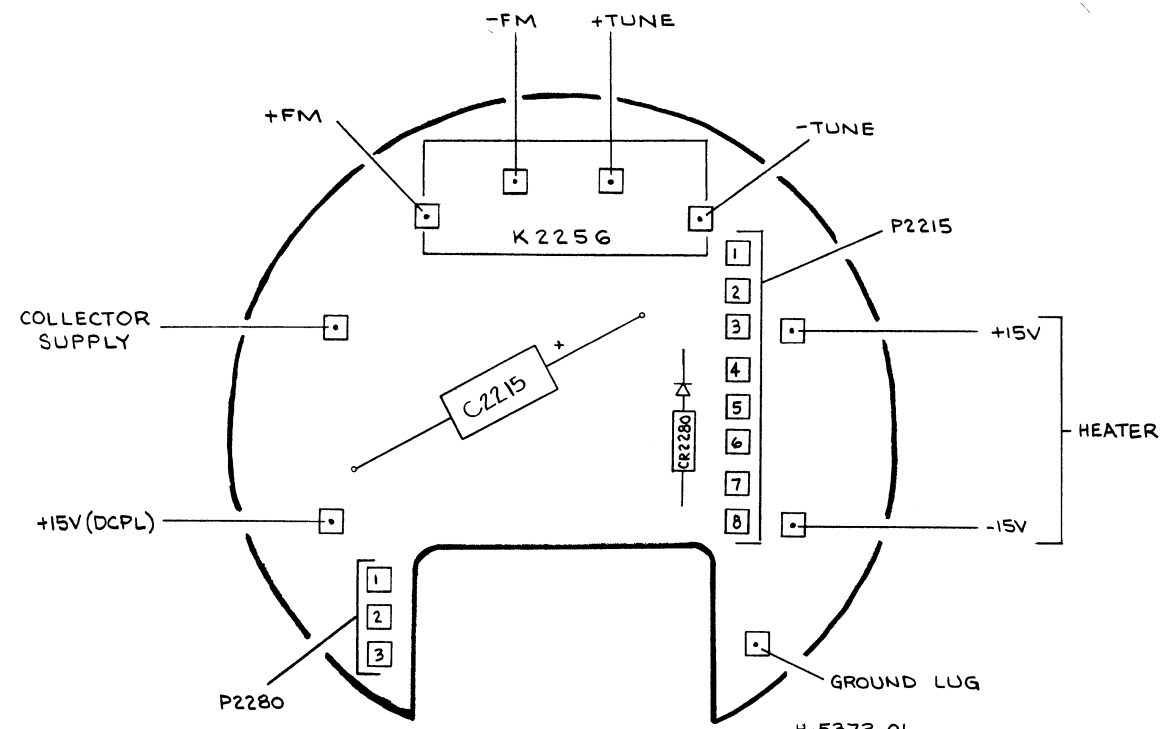

7L18 A60A1 1ST LO BOARD

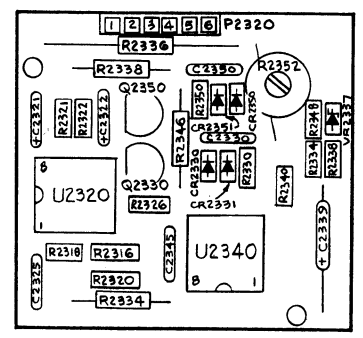

H-5026-01
7L18 A2316 REFERENCE VOLTAGES

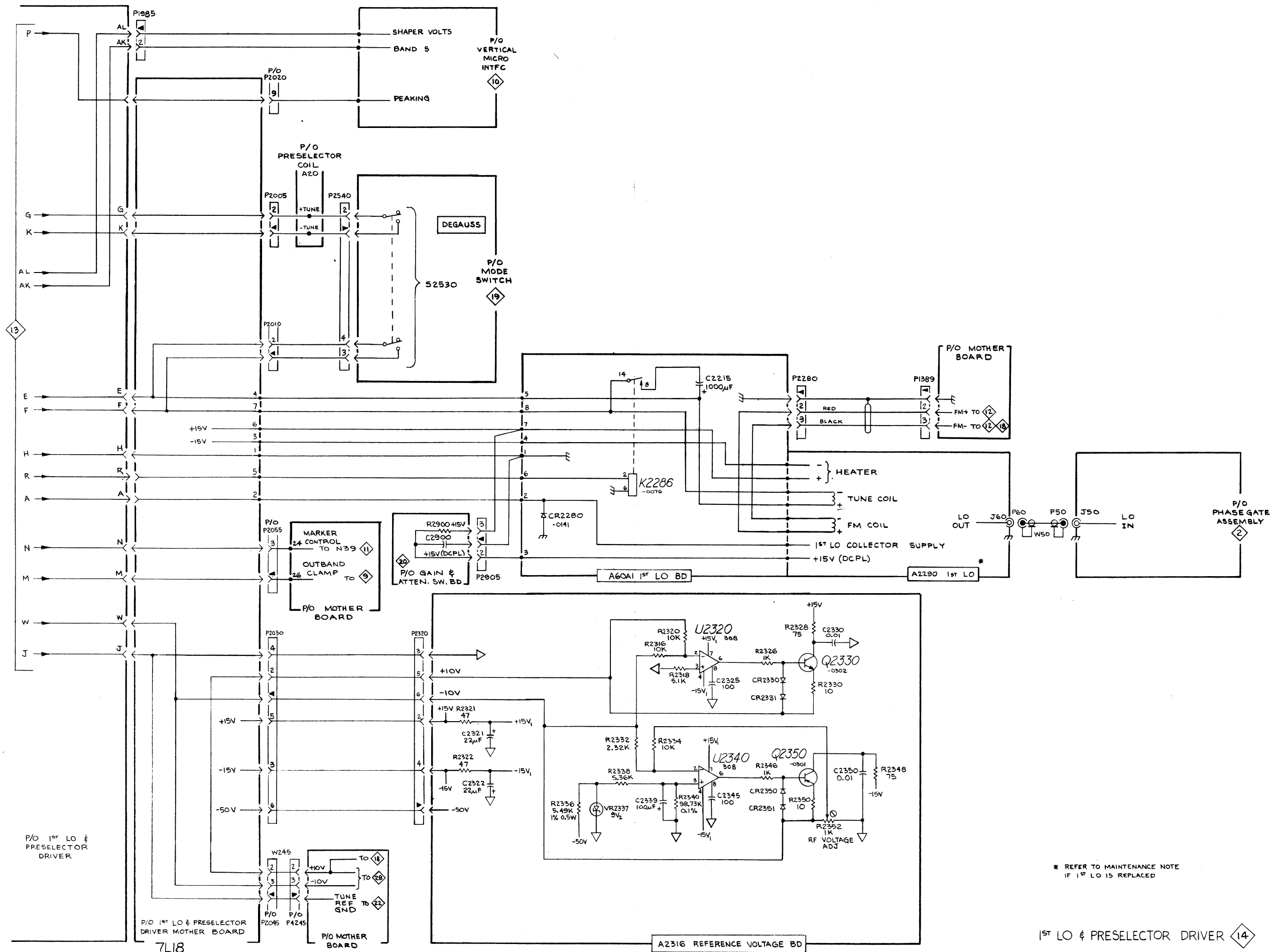

* REFER TO MAINTENANCE NOTE
IF 1st LO IS REPLACED

1st LO & PRESELECTOR DRIVER 14

1st LO & REFERENCE
VOLTAGE BOARD

14

13

7L18

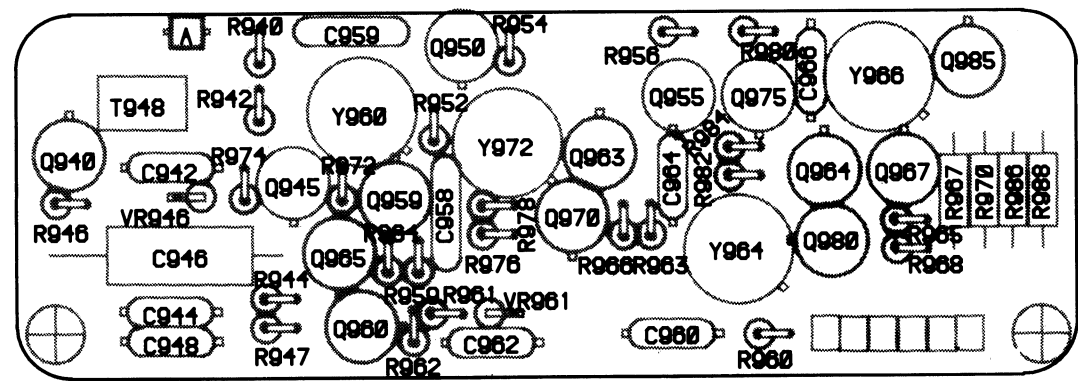

2295 97
A940A1 H-5013-02 REFERENCE OSCILLATOR

7LI8

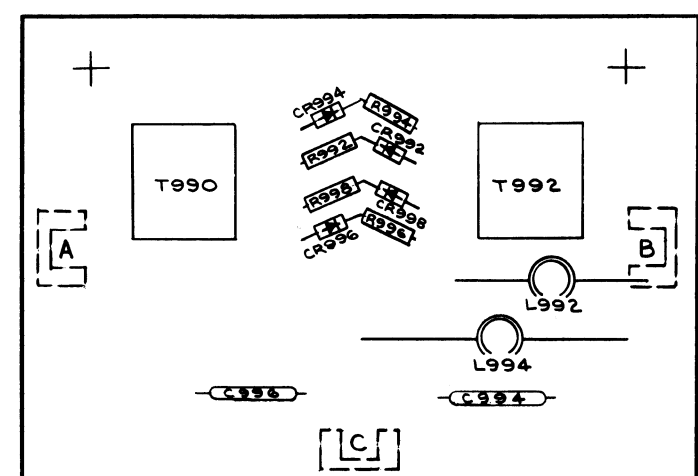

2295 98
H-5013-01 A940A2 MIXER

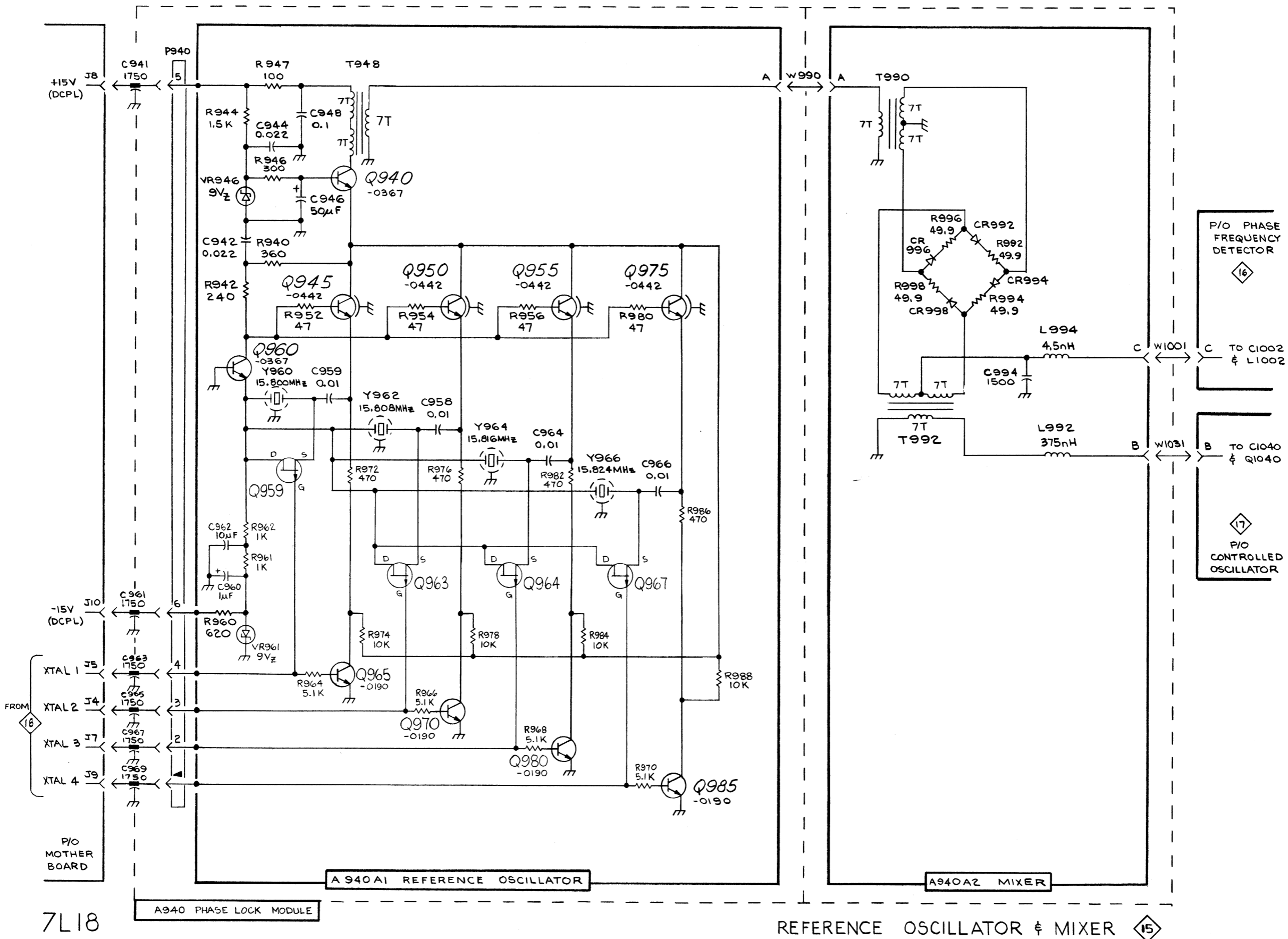

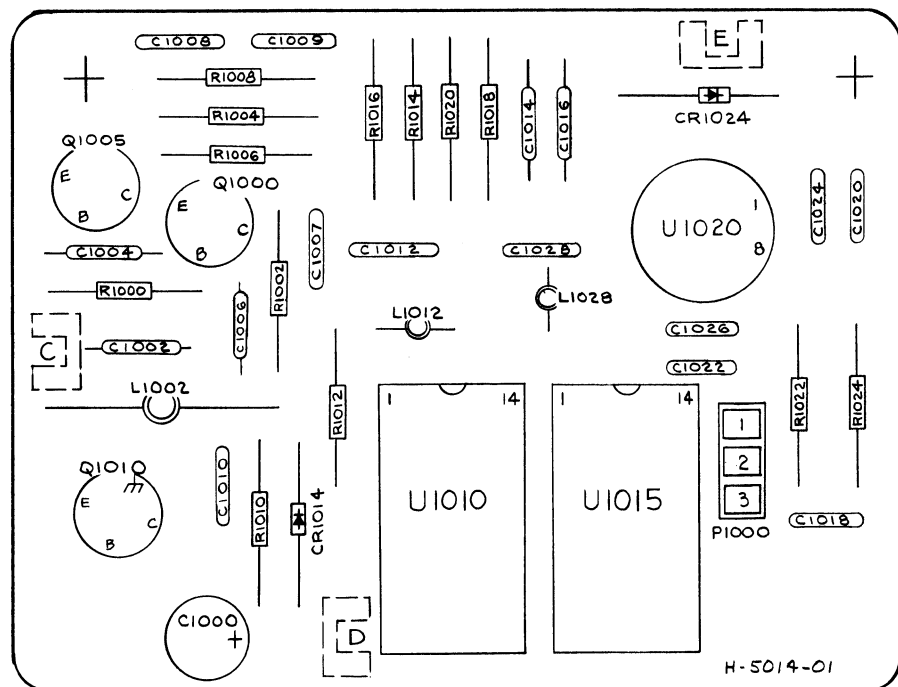

7L18 A940A3 PHASE/FREQUENCY DETECTOR

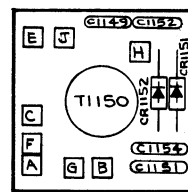

7L18 H-5045-01
A940A7A2 OFFSET OSCILLATOR RESONATOR

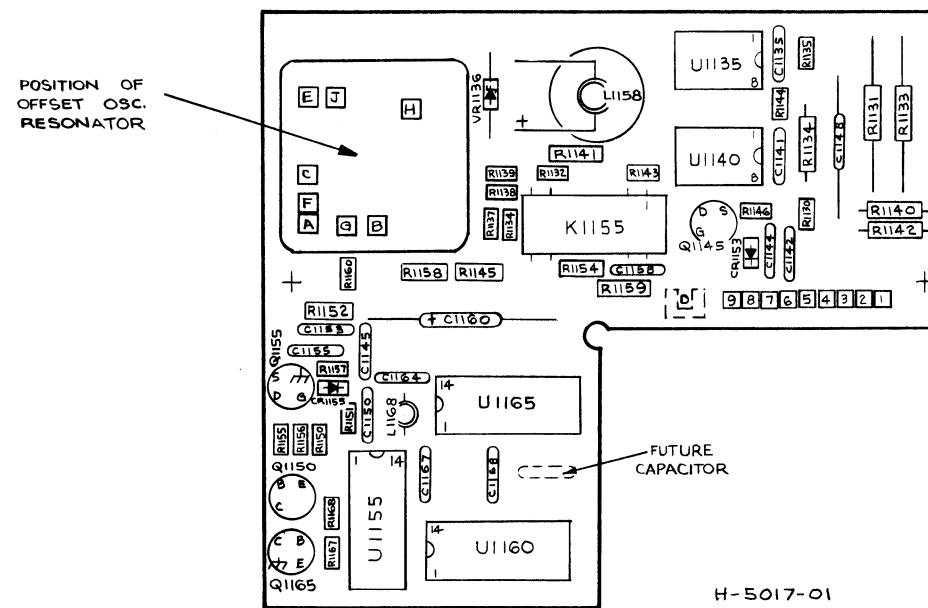

7L18 A940A7A1 OFFSET OSCILLATOR

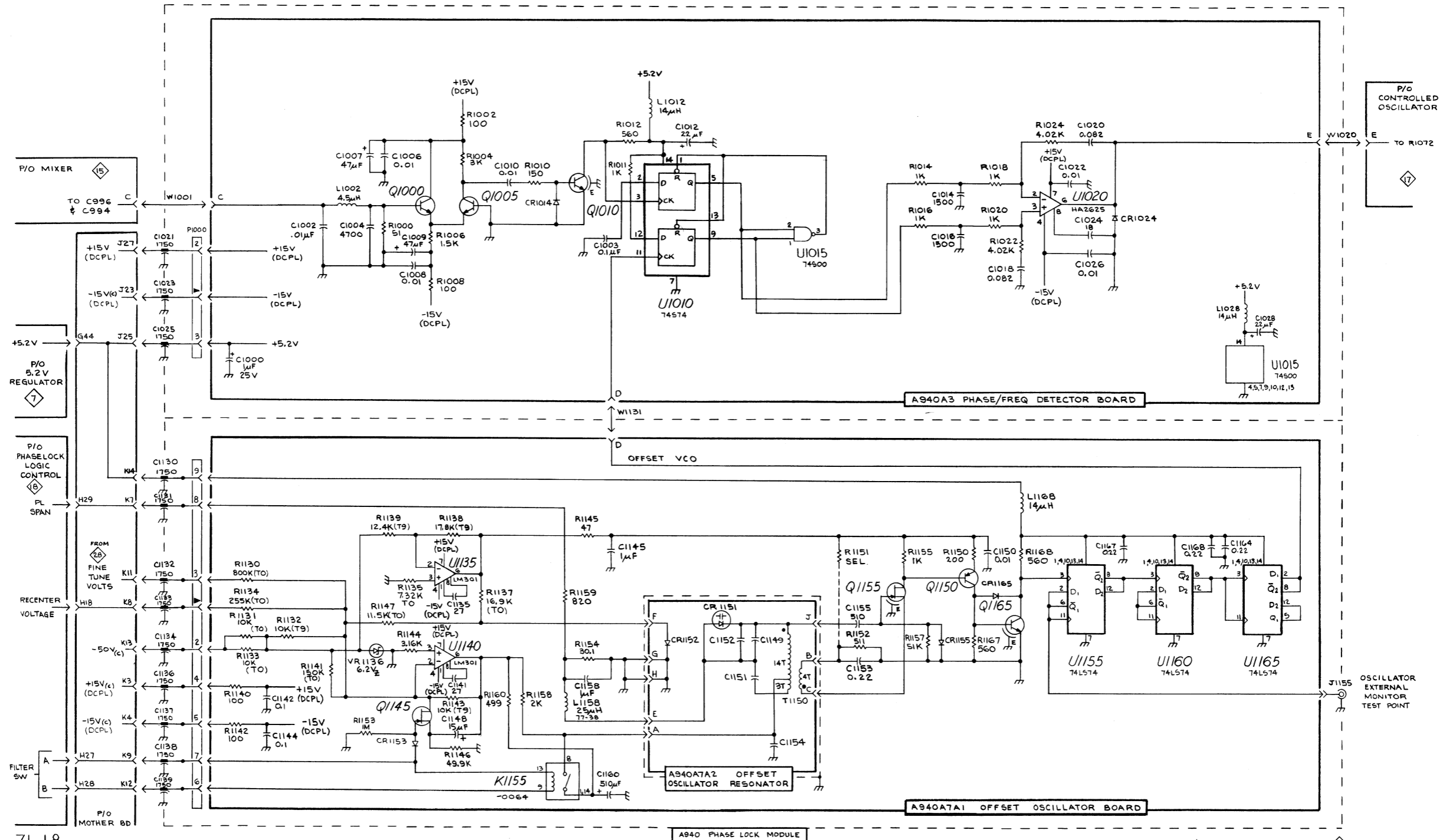

7L18

OFFSET OSCILLATOR, PHASE/FREQ. DETECTOR 16

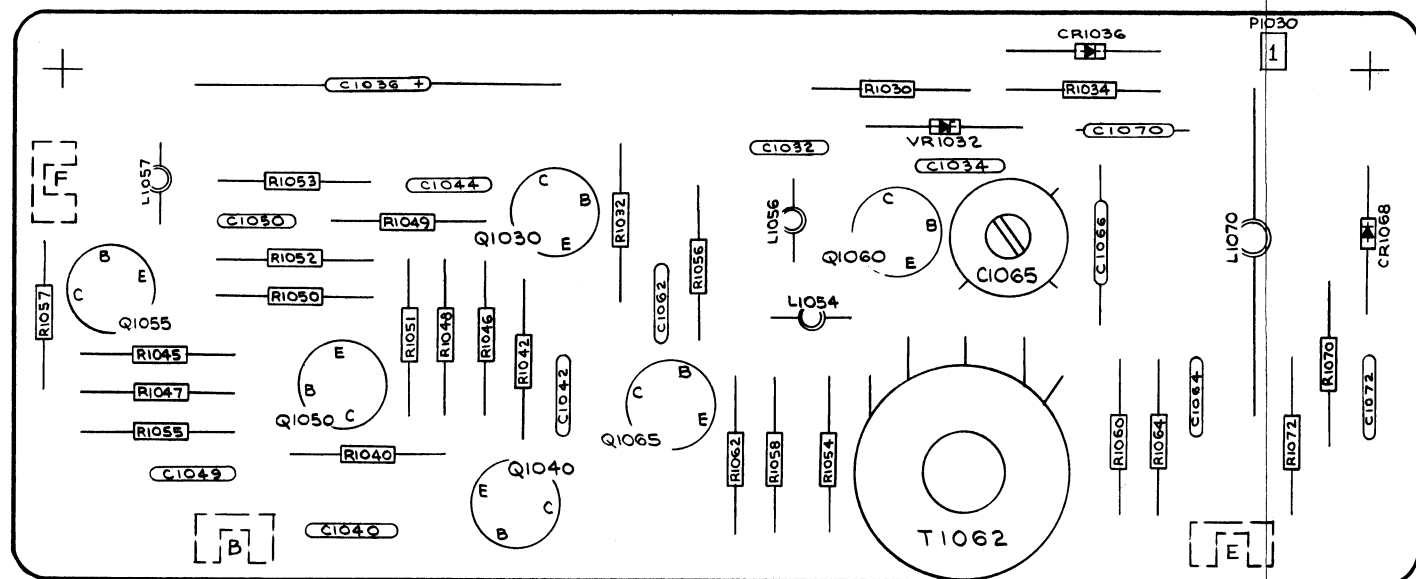

7L18

H-5016-01

A940A4 CONTROLLED OSCILLATOR

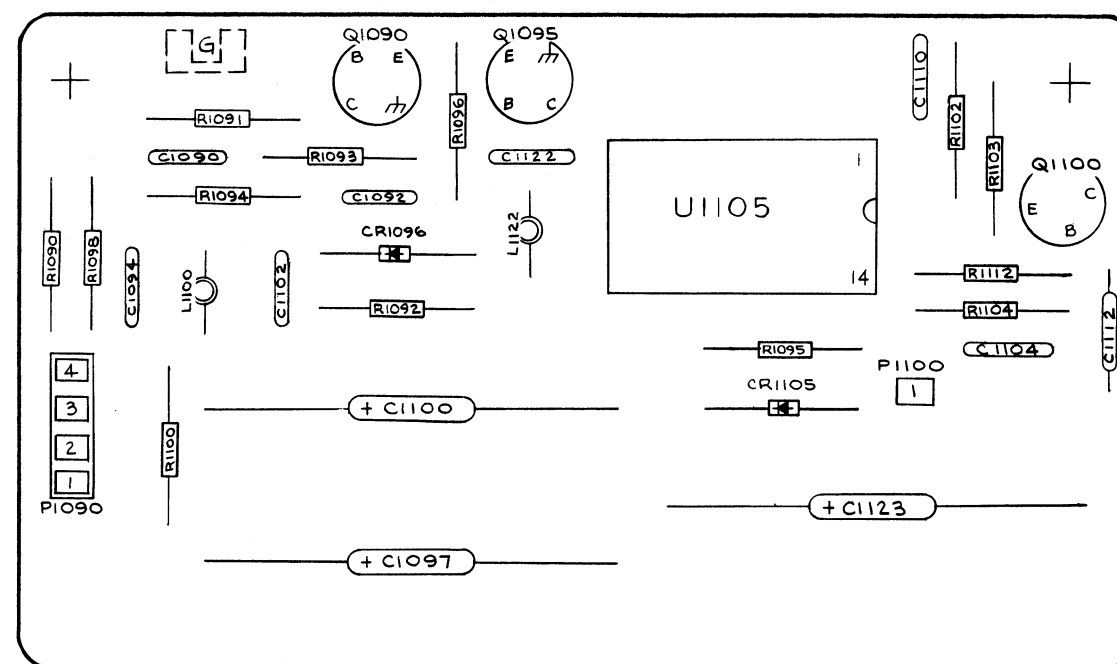

7L18

H-5018-01

A940A6 STROBE DRIVER

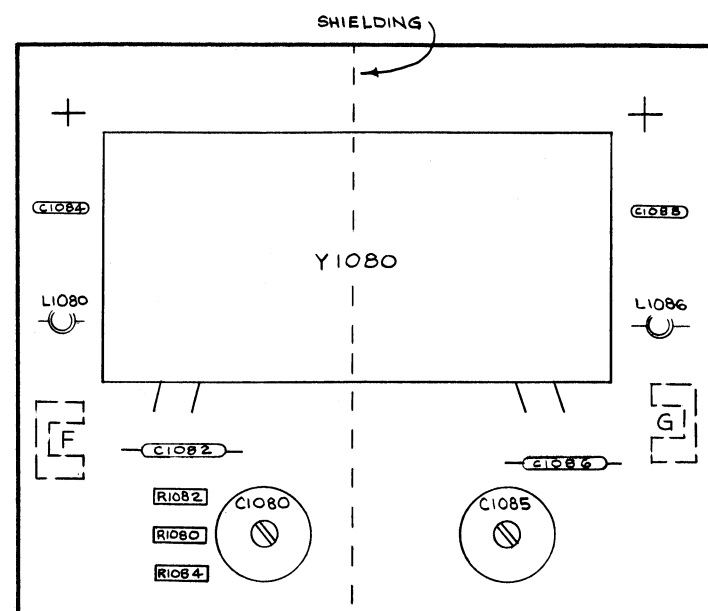

7L18 H-5019-01 A940A5 16MHz FILTER

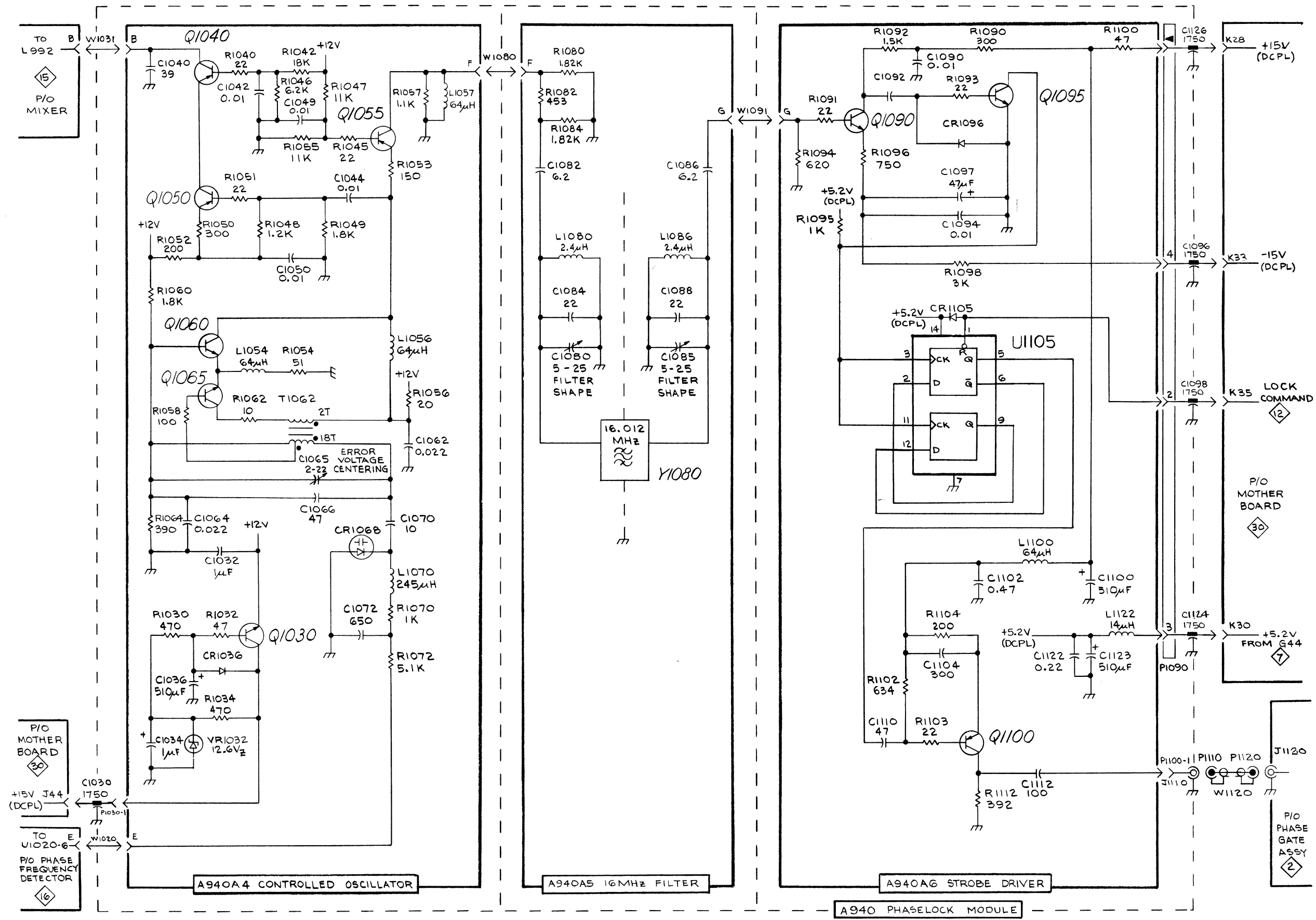

7L18

CONTROLLED OSCILLATOR, 16MHz FILTER & STROBE DRIVER

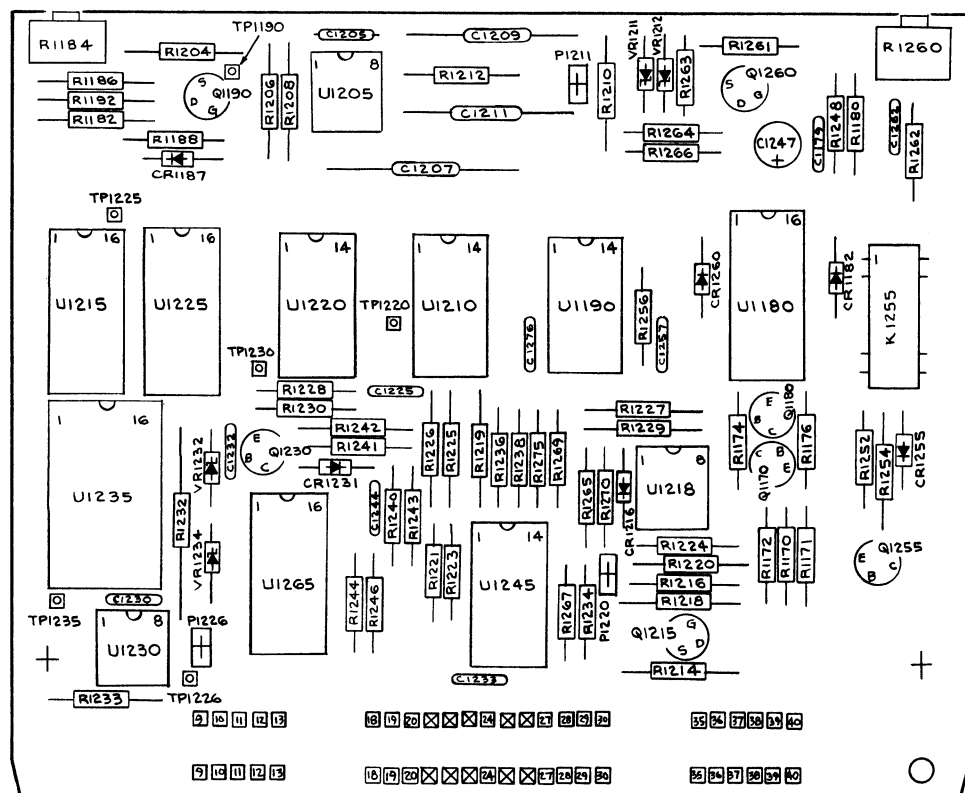

7L18 H-5011-01 A1170 PHASELOCK LOGIC CONTROL

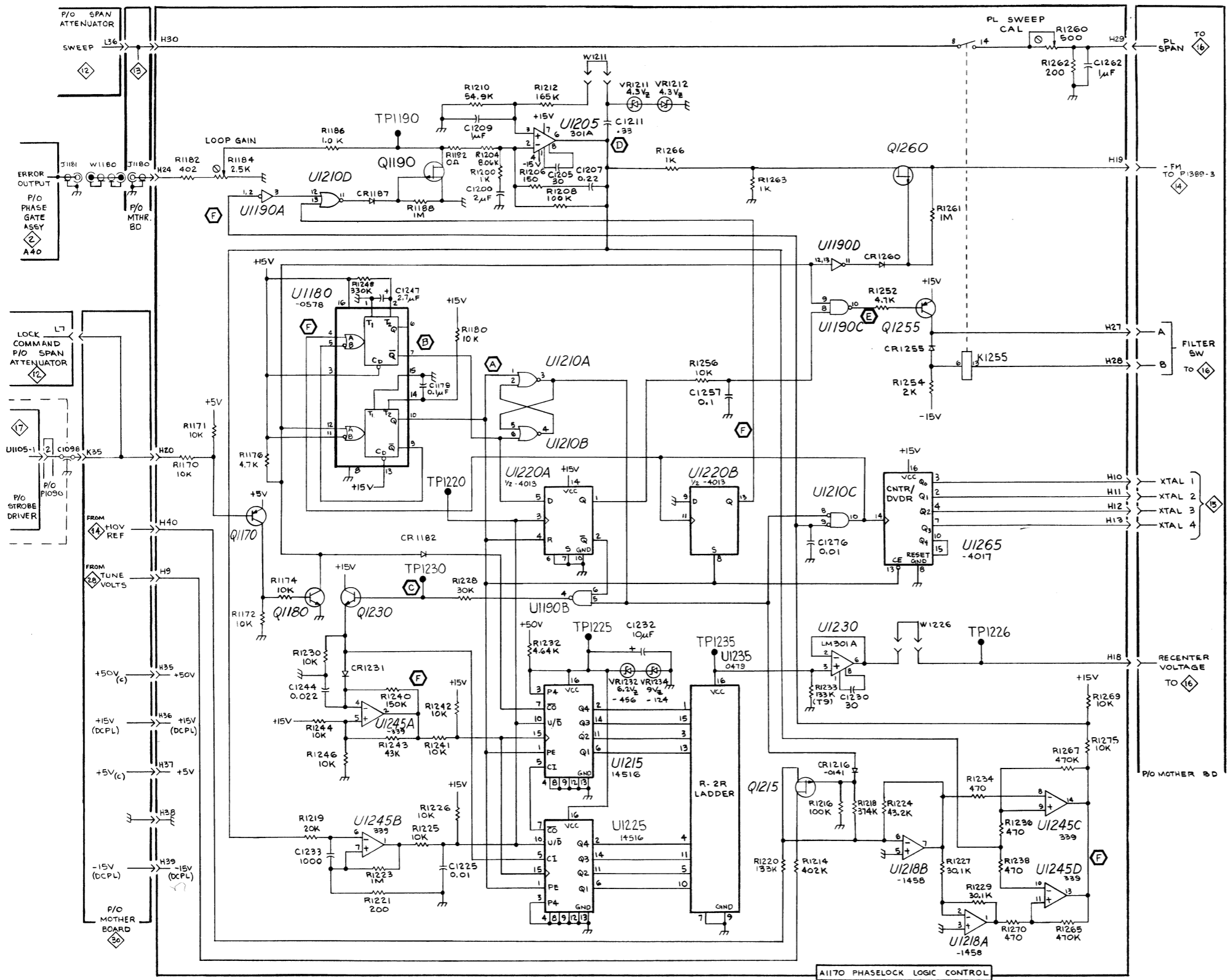

PHASELOCK LOGIC TIMING DIAGRAM

PHASELOCK ON PL 5 PL 15	
INITIAL T.D. & PRESET	
U1210A PIN 3 COMMUTATE SWITCH	
LOCK SENSE	
CLOCK SWITCH	
SEARCH	
SPAN SW & FILTER SW	
LOCK RANGE	
XTAL 1	
XTAL 2	
XTAL 3	
XTAL 4	

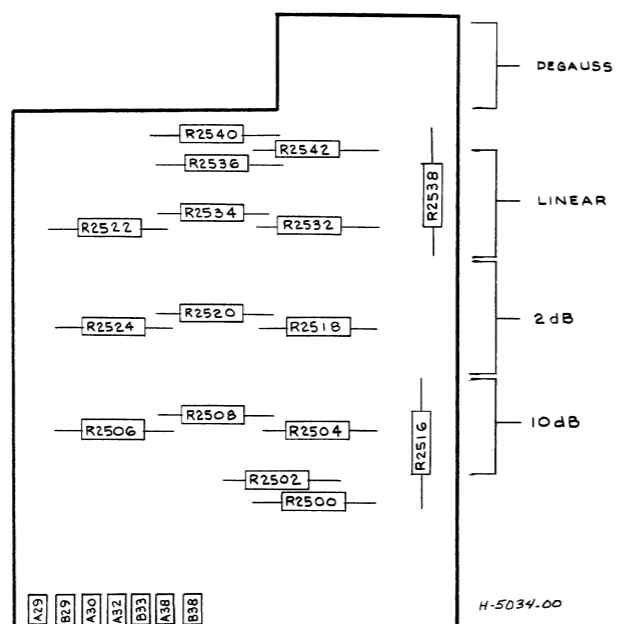

7L18 A2500 DISPLAY MODE SWITCHES (TOP) H-5034-00

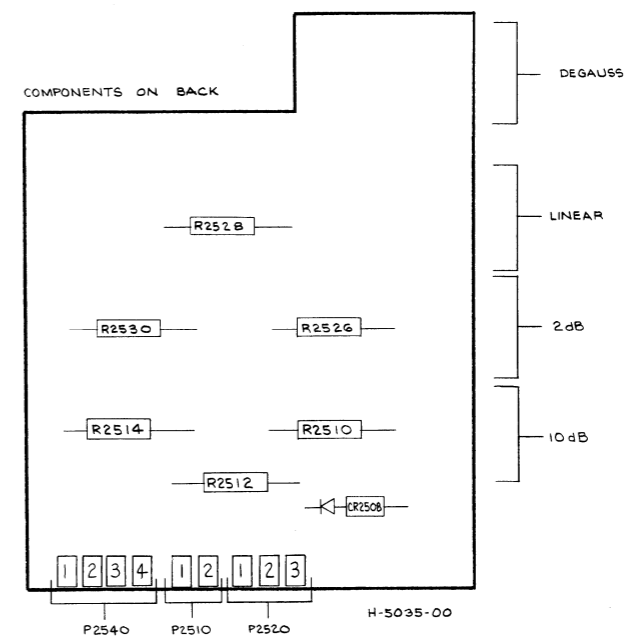

7L18 A2500 DISPLAY MODE SWITCHES (BOTTOM) H-5035-00

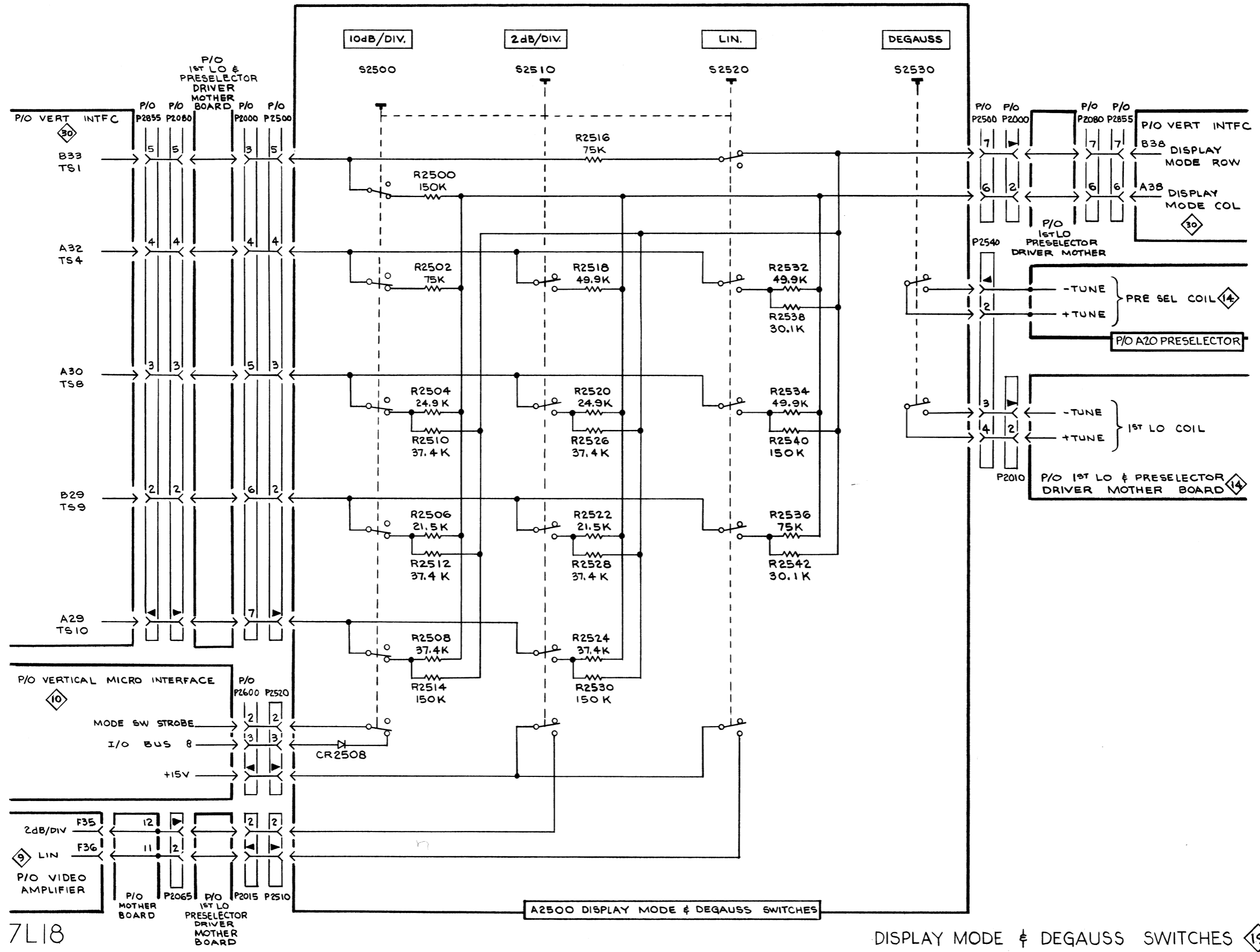

7L18

DISPLAY MODE & DEGAUSS SWITCHES 19

DISPLAY MODE & DEGAUSS SWITCHES

19

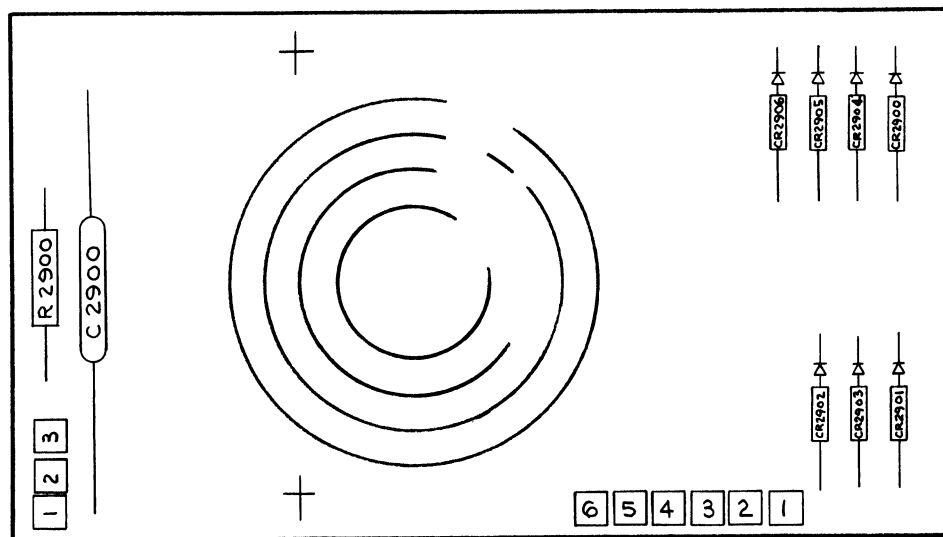

H-5044-01

7L18

AIO RF ATTEN & IF GAIN SWITCH

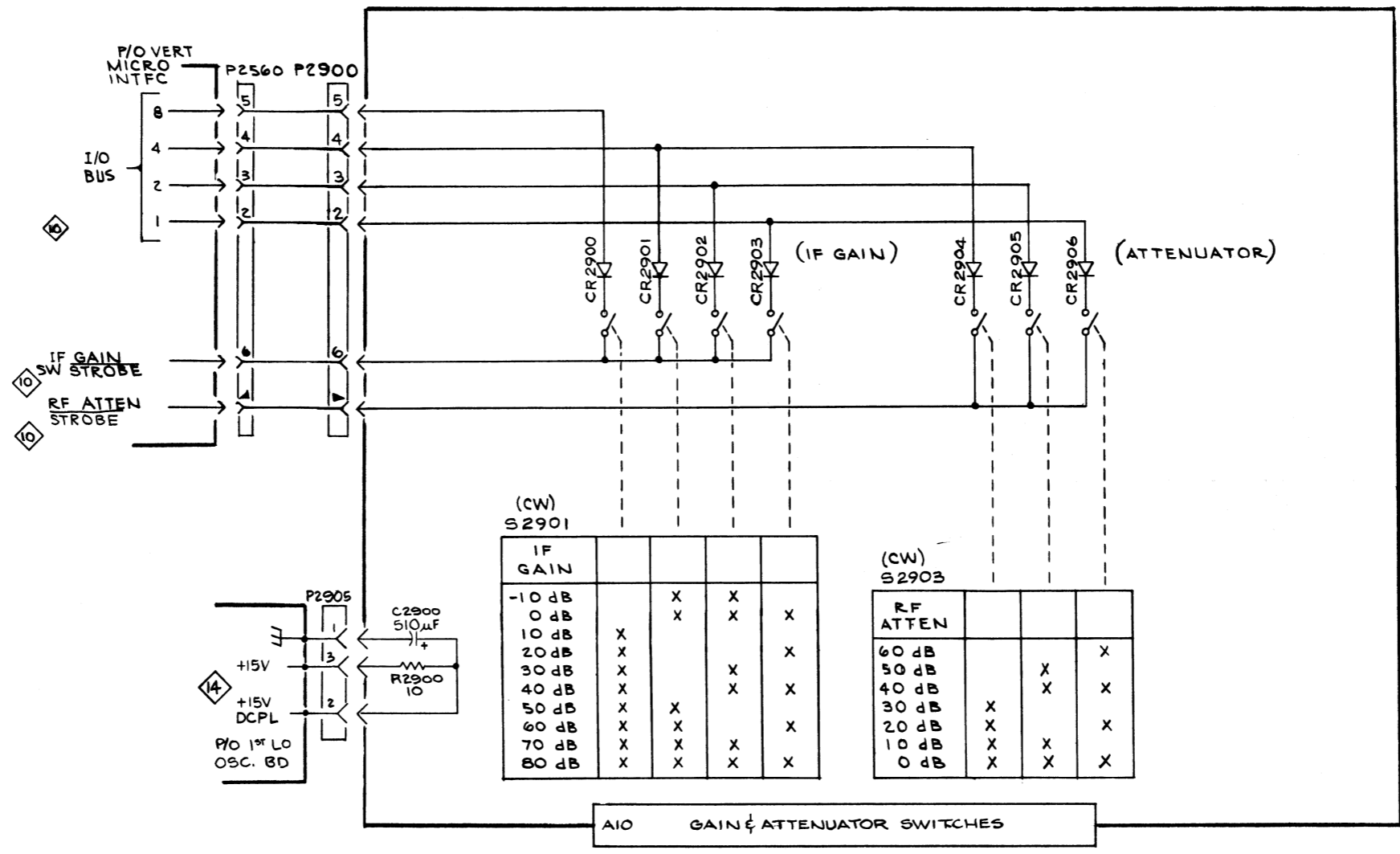

IF GAIN				
-10 dB		X	X	X
0 dB		X	X	X
10 dB	X			
20 dB	X			X
30 dB	X		X	X
40 dB	X		X	X
50 dB	X	X		
60 dB	X	X		X
70 dB	X	X	X	
80 dB	X	X	X	X

RF ATTEN			
60 dB			X
50 dB		X	
40 dB		X	X
30 dB			
20 dB	X		X
10 dB	X	X	
0 dB	X	X	X

7L18

GAIN & ATTENUATOR SWITCHES 20

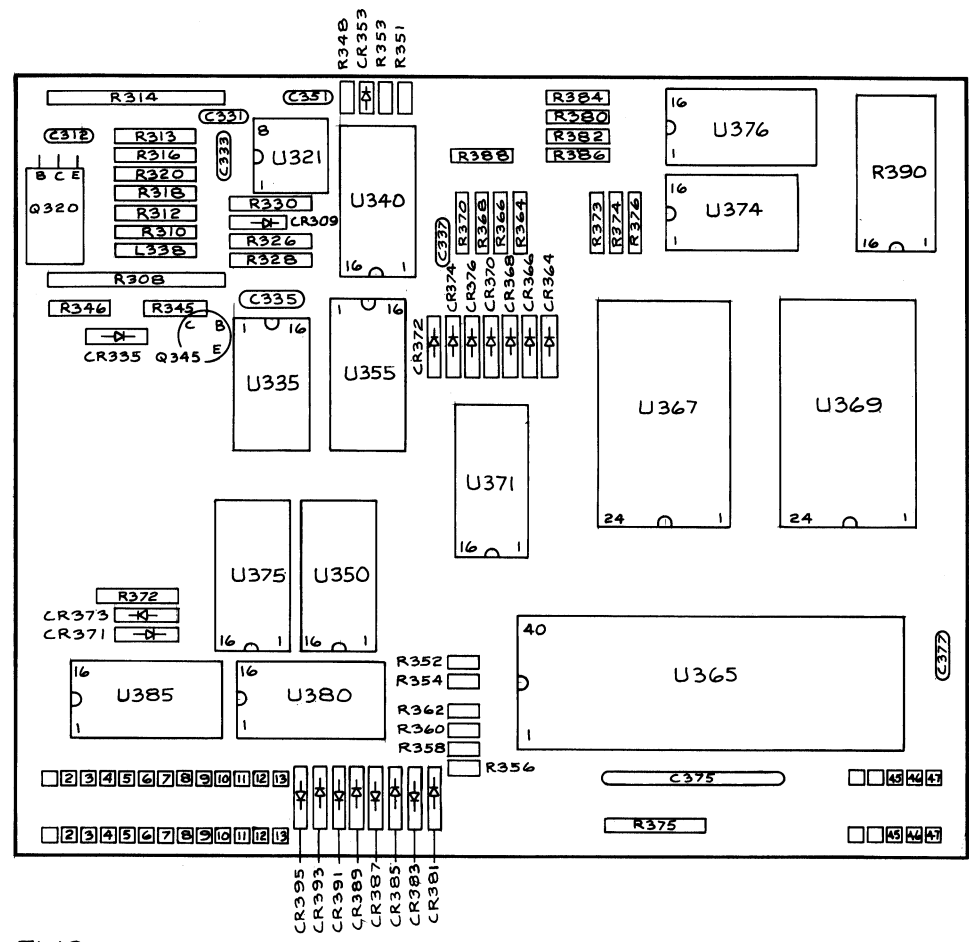

7L18

H-5043-03

A300 MICROCOMPUTER

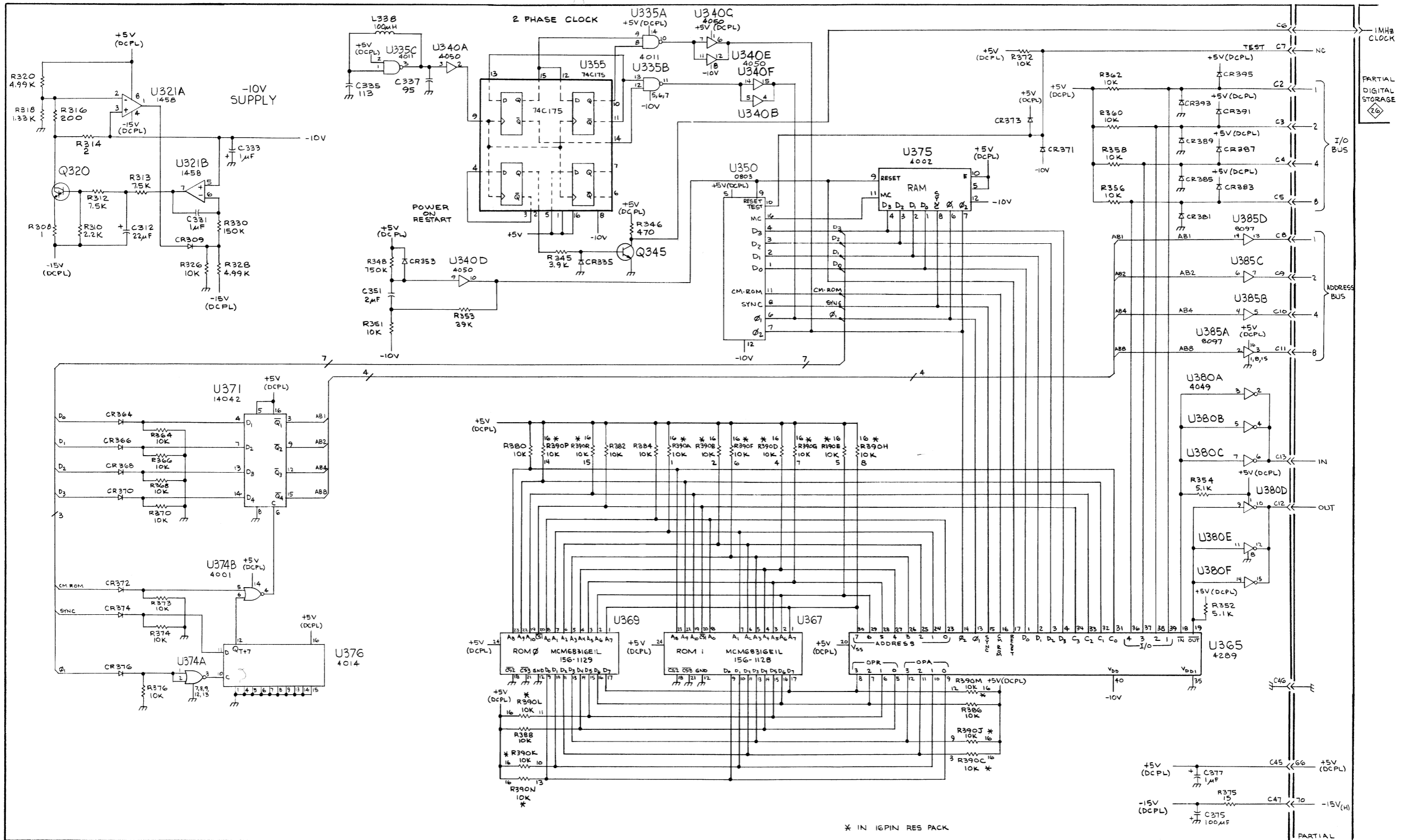

* IN 16PIN RES PACK

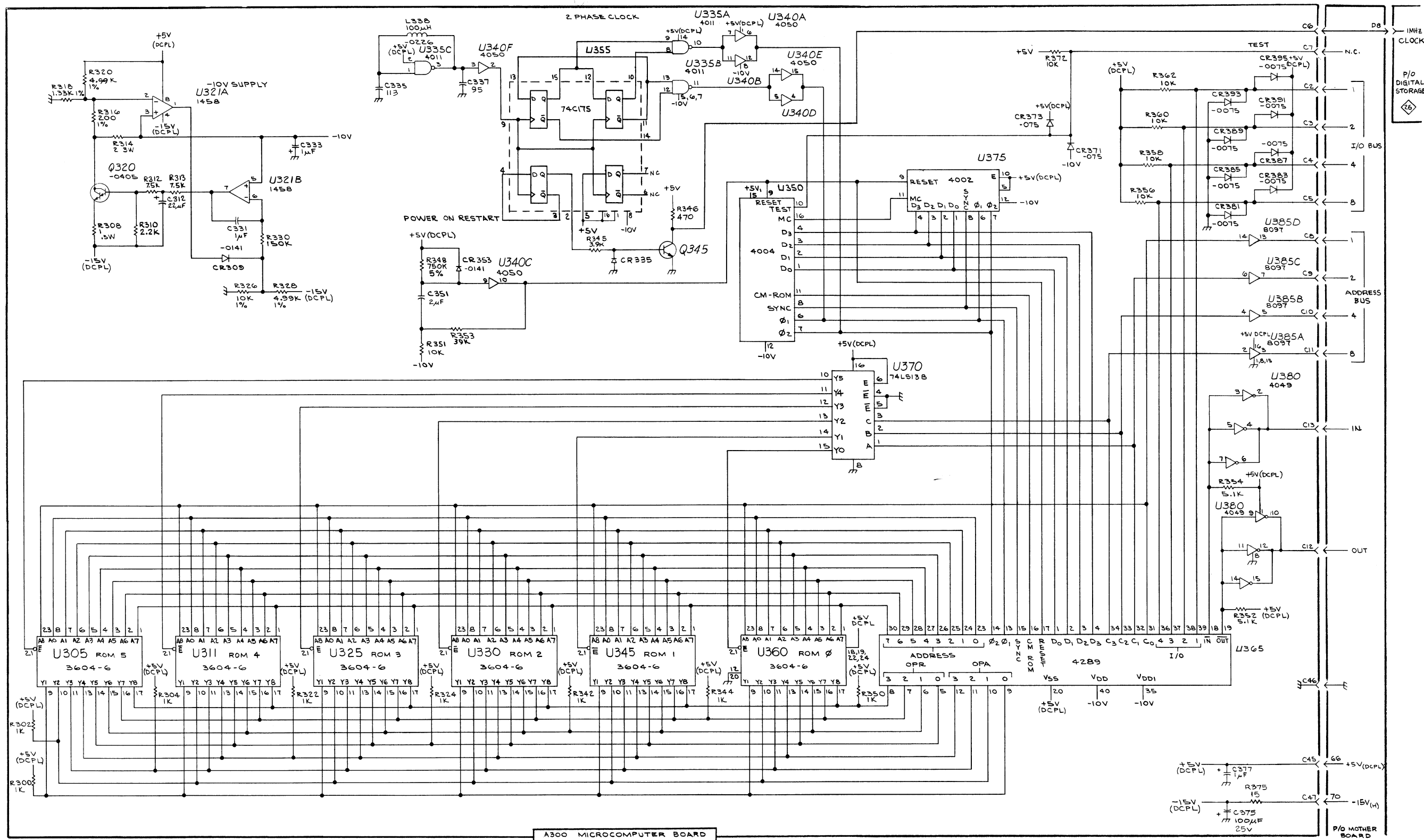

7L18

670-4505-00
MICROCOMPUTER

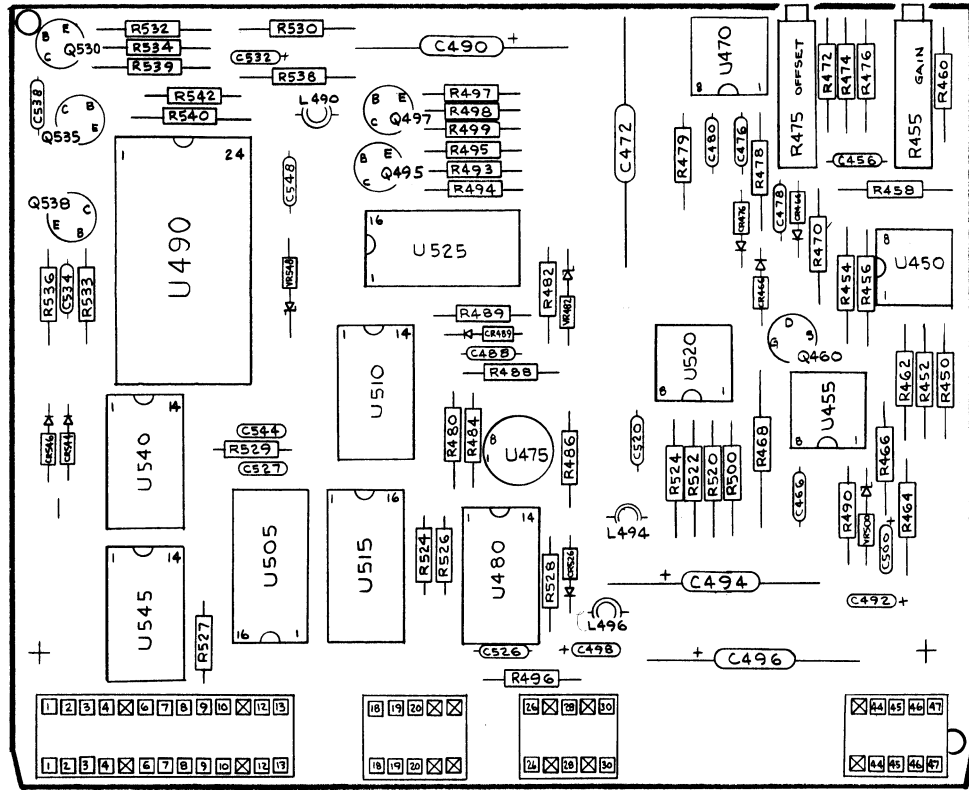

7L18 H-5010-01 A450 CENTER FREQUENCY DVM

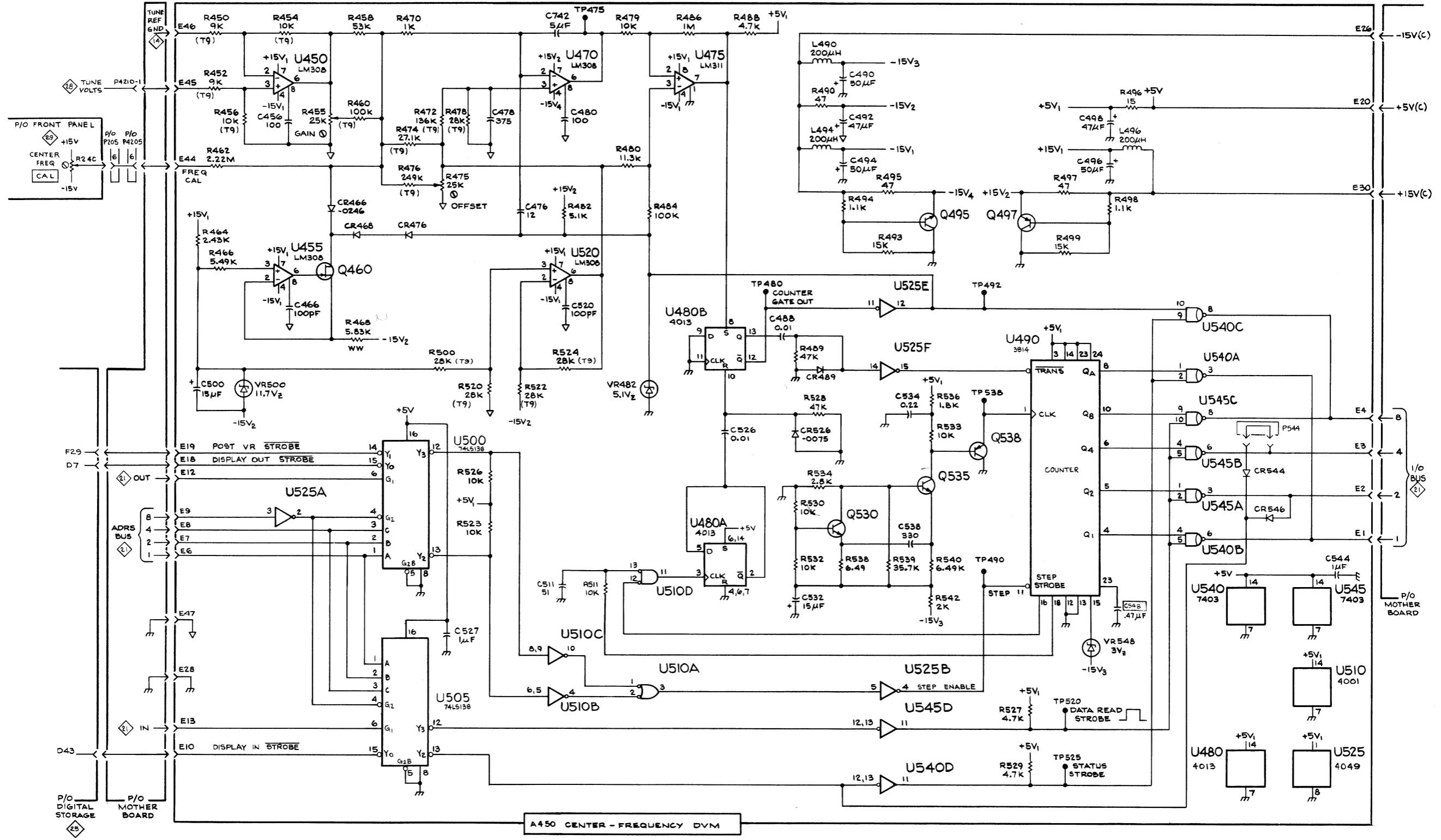

7L18

A450 CENTER-FREQUENCY DVM

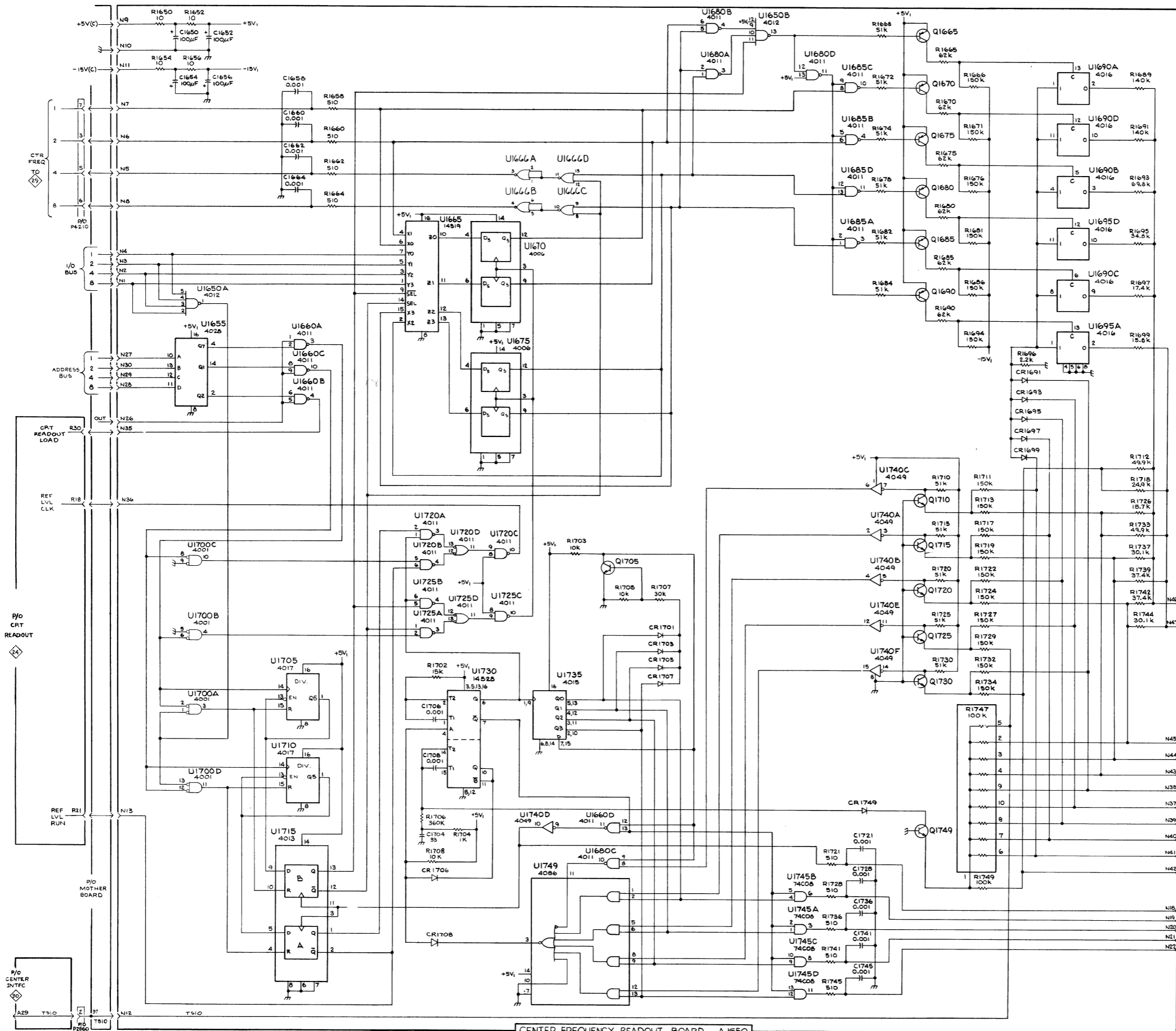

CKT SYM	DEVICE	NAME	VCC	GND	VDD
U1700	4001	QUAD NOR GATE	14	7	
U1670, U1675	4006	SHIFT REGISTER	14	7	
U1660, U1680, U1685, U1720, U1725	4011	QUAD NAND GATE	14	7	
U1650	4012	DUAL NAND GATE	14	7	
U1715	4013	DUAL 'D' FLIP-FLOP	14	7	
U1735	4015	SHIFT REGISTER	16	8	
U1690, U1695	4016	QUAD BILATERAL SW	7	14	
U1705, U1710	4017	DECADE COUNT/DIVIDE	16	8	
U1655	4028	BCD-DECIMAL DECODER	16	8	
U1740	4049	HEX BUFFER	1	8	
U1749	4086	AND-OR-INVERT	14	7	
U1665	14519	AND-OR-SELECT	16	8	
U1730	14528	DUAL 1-SHOT MUX	16	8	
U1745	74C08	INPUT AND GATE	14	7	

ALL DIODES 152-0141

CENTER FREQUENCY READOUT BOARD A1650

CENTER FREQUENCY READOUT

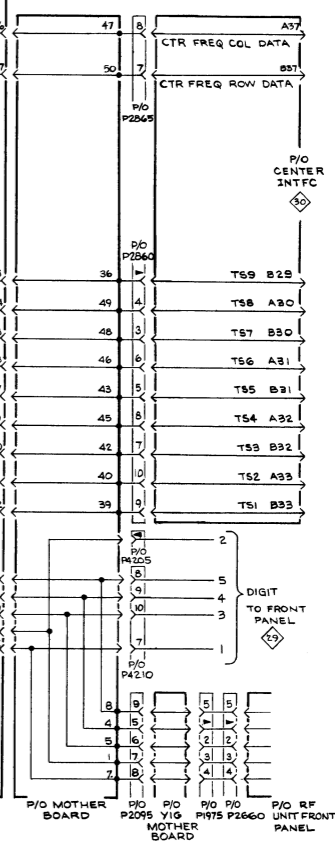

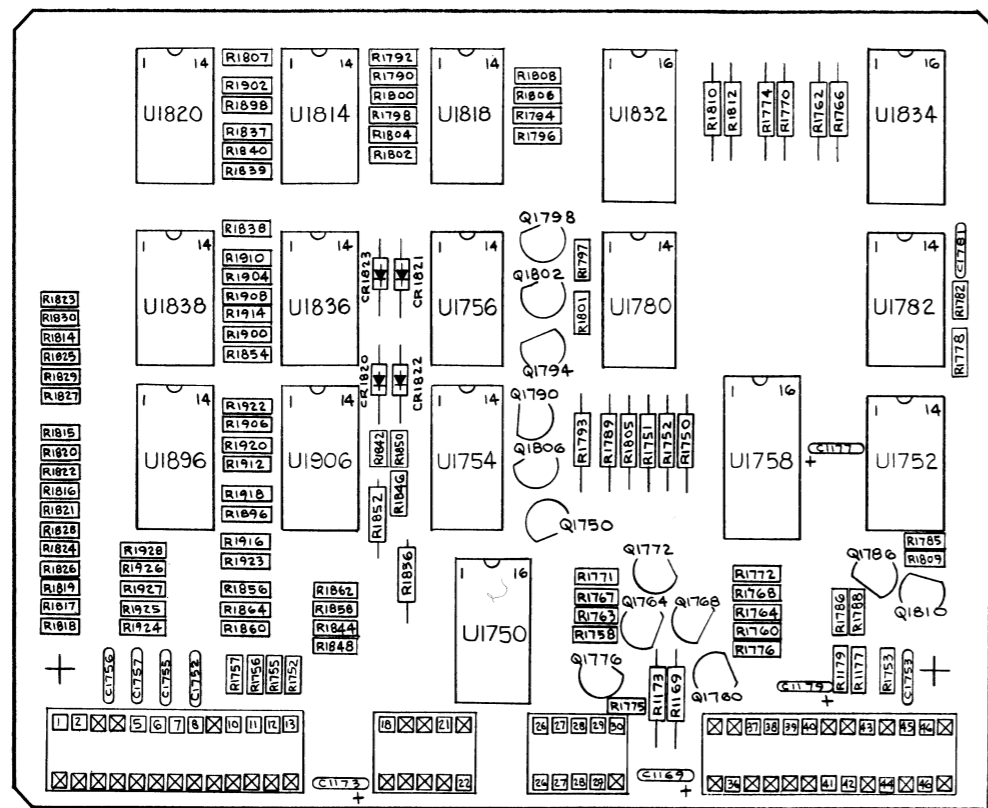

7L18

H-5024-02

AI750 CRT READOUT

CRT READOUT

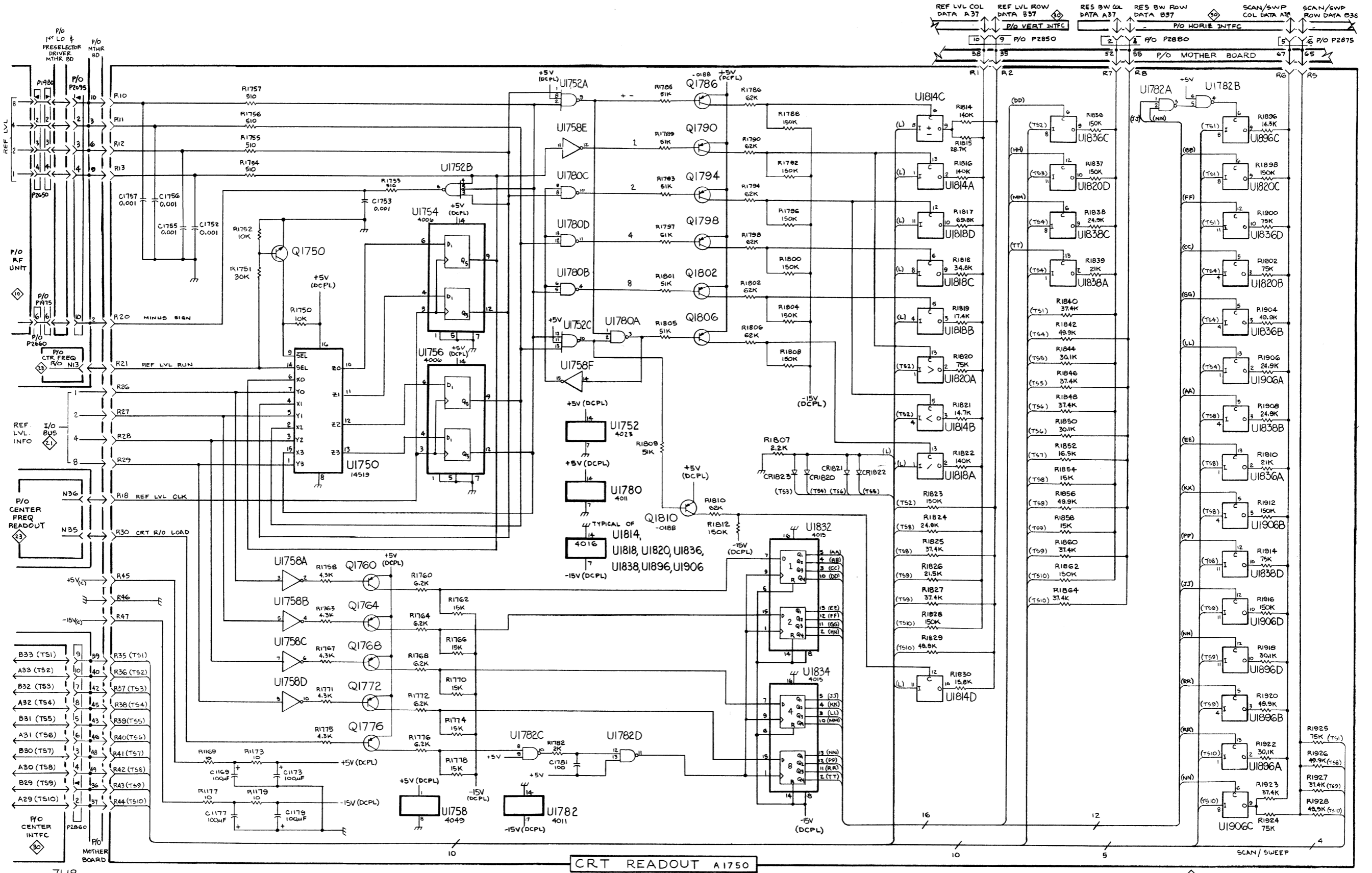

7L18

CRT READOUT A1750

CRT READOUT

CRT READOUT

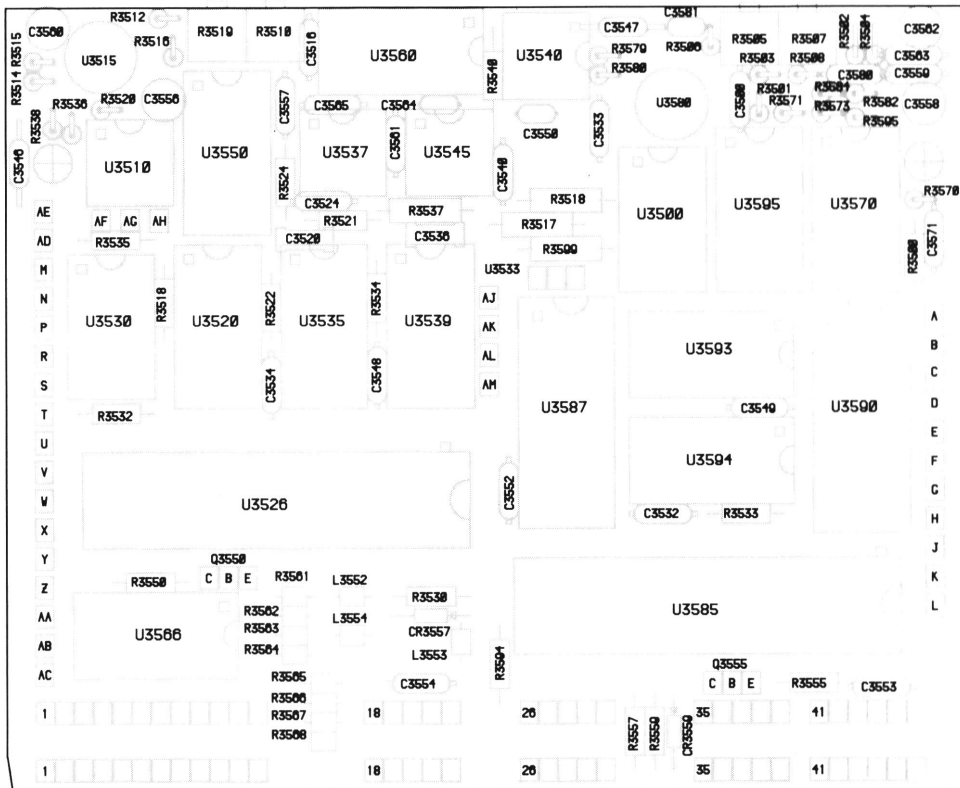

2295 121

7L18

H-500B-01 DIGITAL STORAGE A40

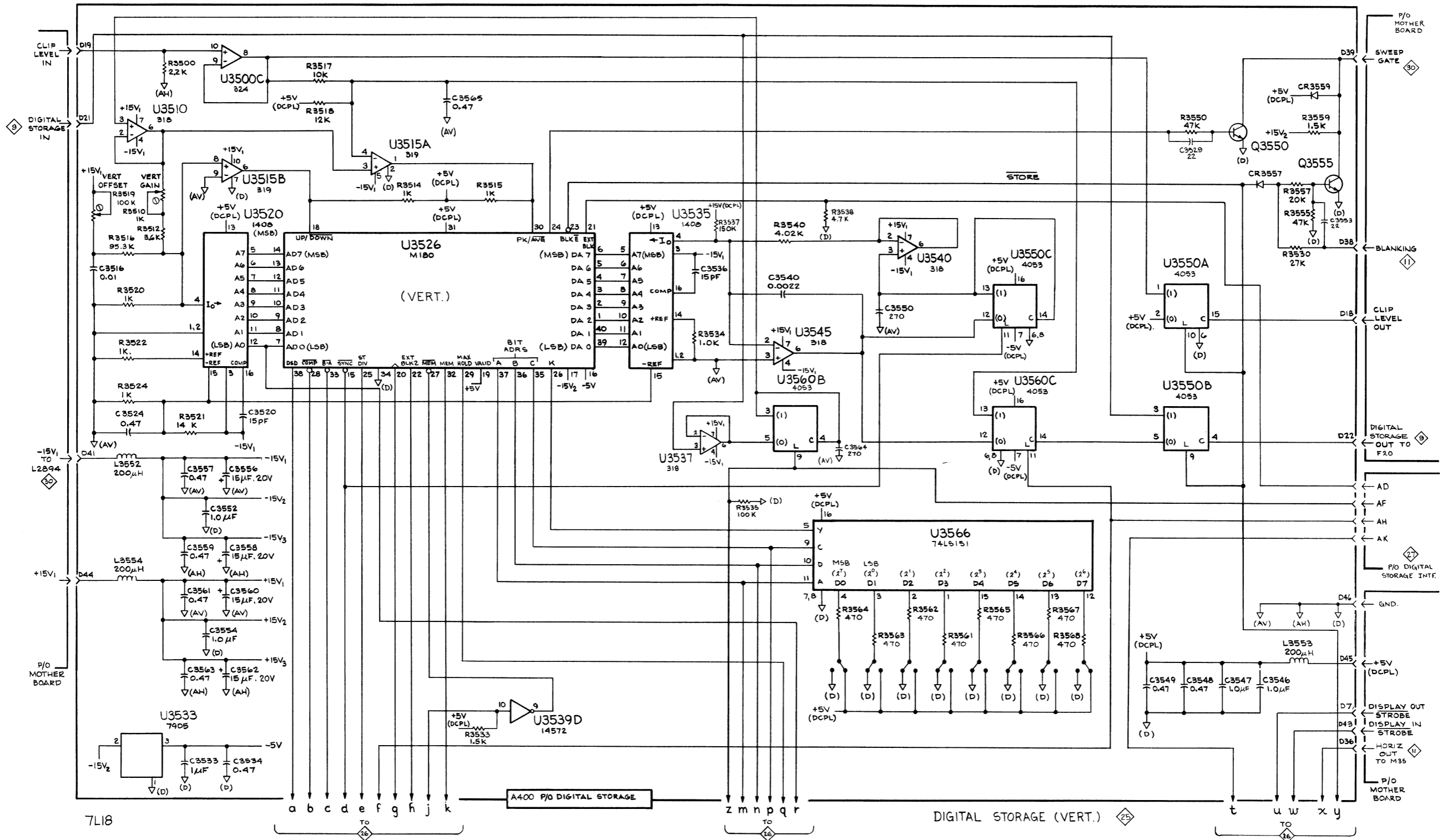

7L18

DIGITAL STORAGE (VERT.)

29

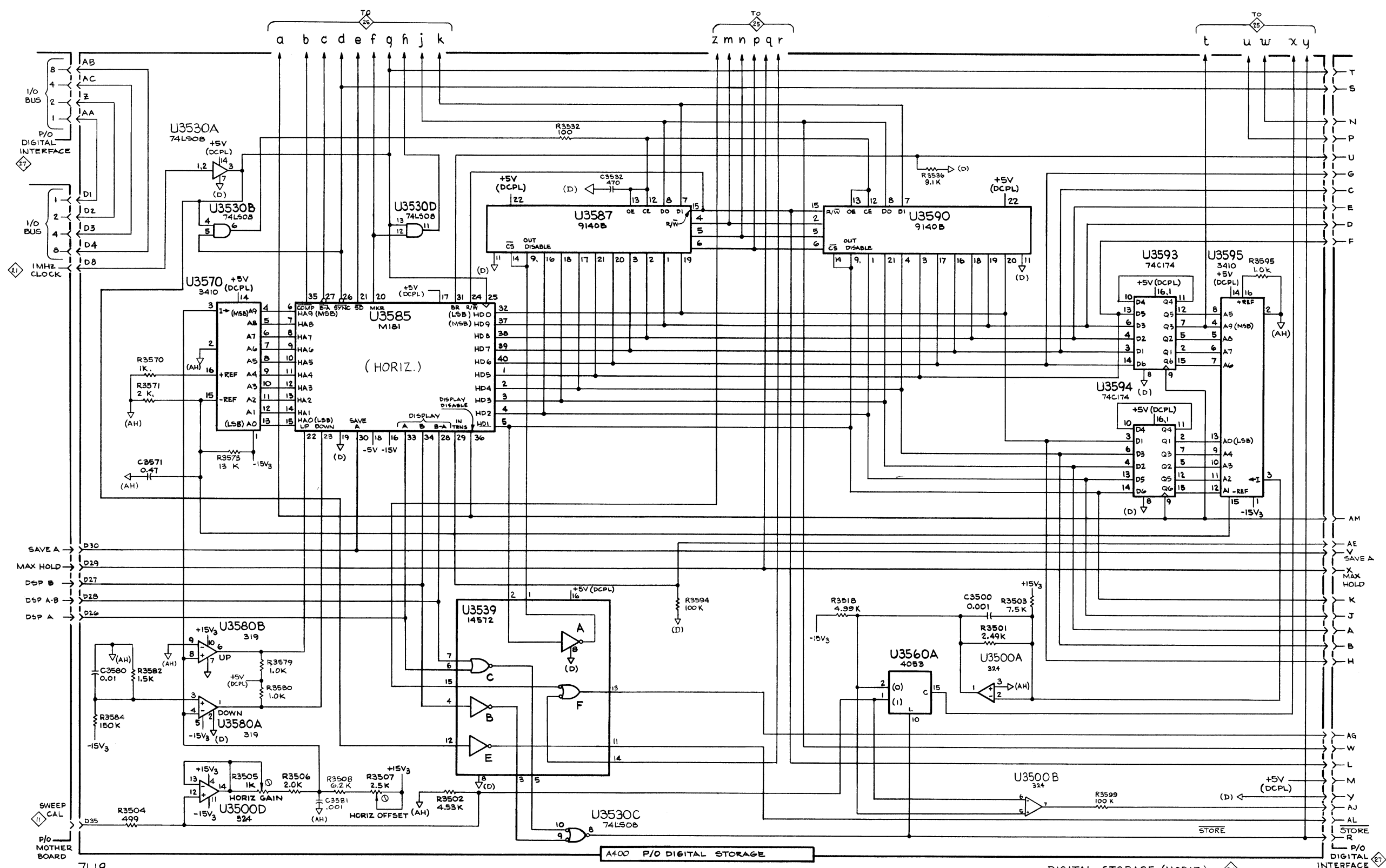

7L18

A400 P/O DIGITAL STORAGE

DIGITAL STORAGE (HORIZ)

INTERFACE

DIGITAL STORAGE

25

26

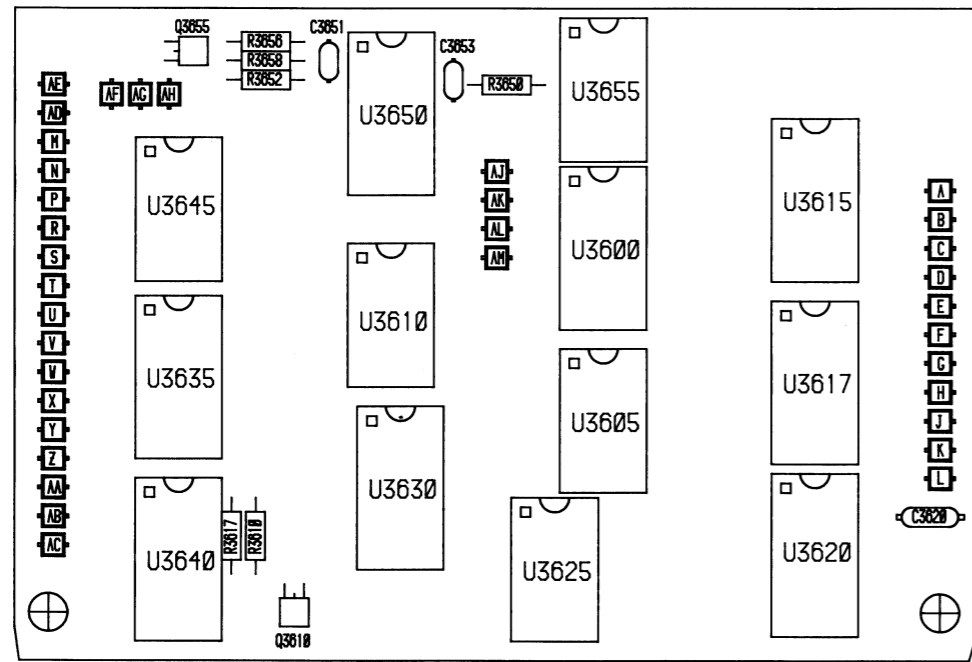

H-4969 DIGITAL STORAGE INTERFACE

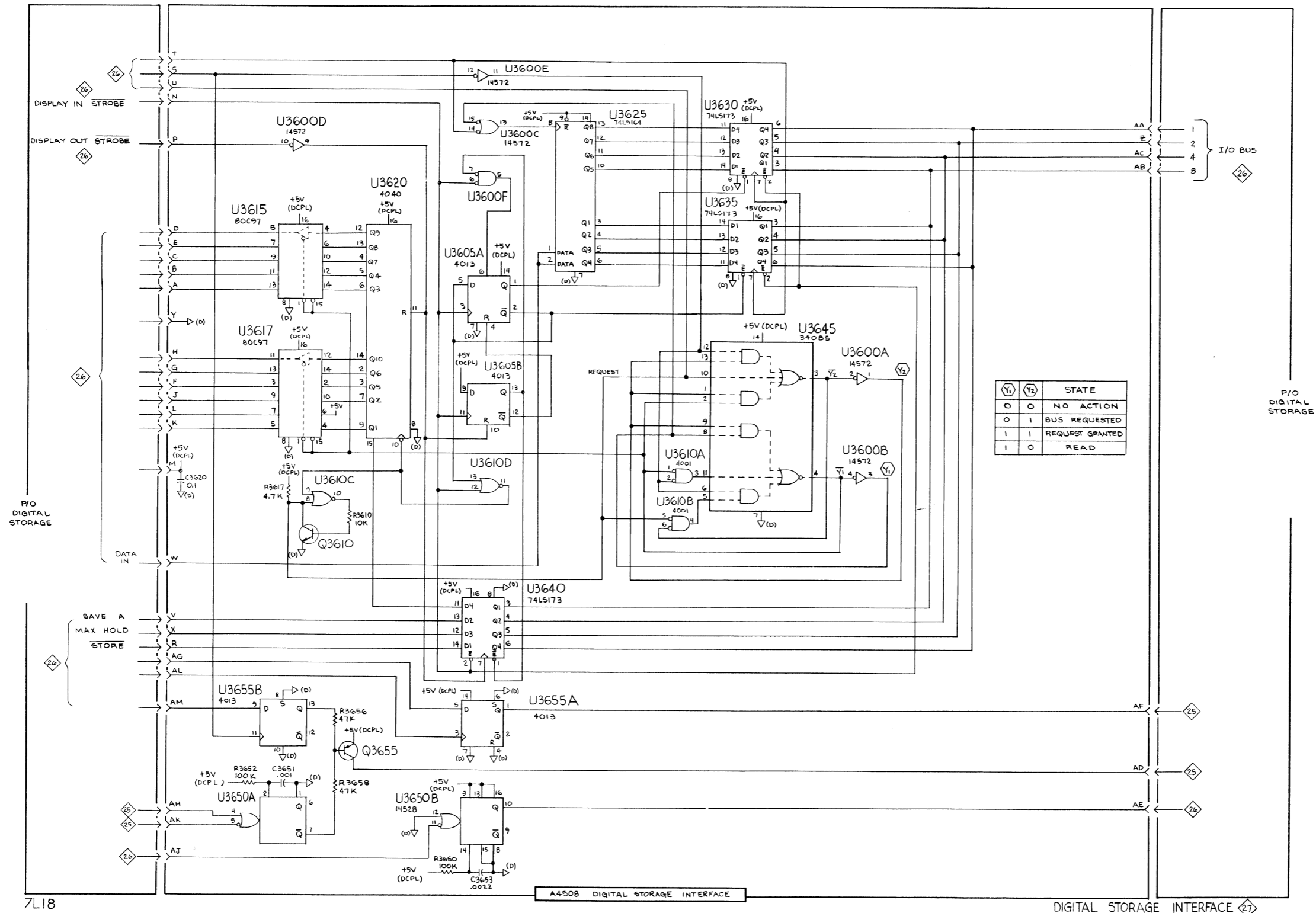

Y ₁	Y ₂	STATE
0	0	NO ACTION
0	1	BUS REQUESTED
1	1	REQUEST GRANTED
1	0	READ

7L18

A450B DIGITAL STORAGE INTERFACE

DIGITAL STORAGE INTERFACE

DIGITAL STORAGE INTERFACE

27

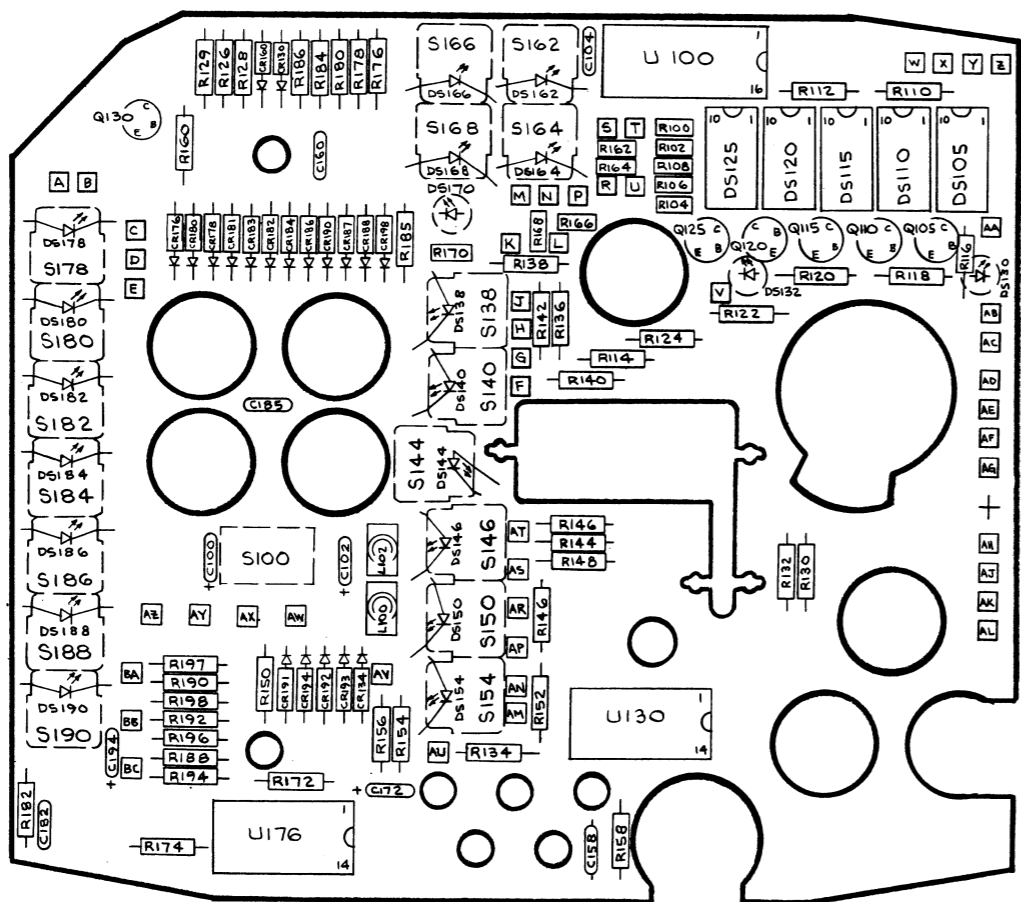

7L18 H-5025-01 A100AI FRONT PANEL BOARD #1

FRONT PANEL #1

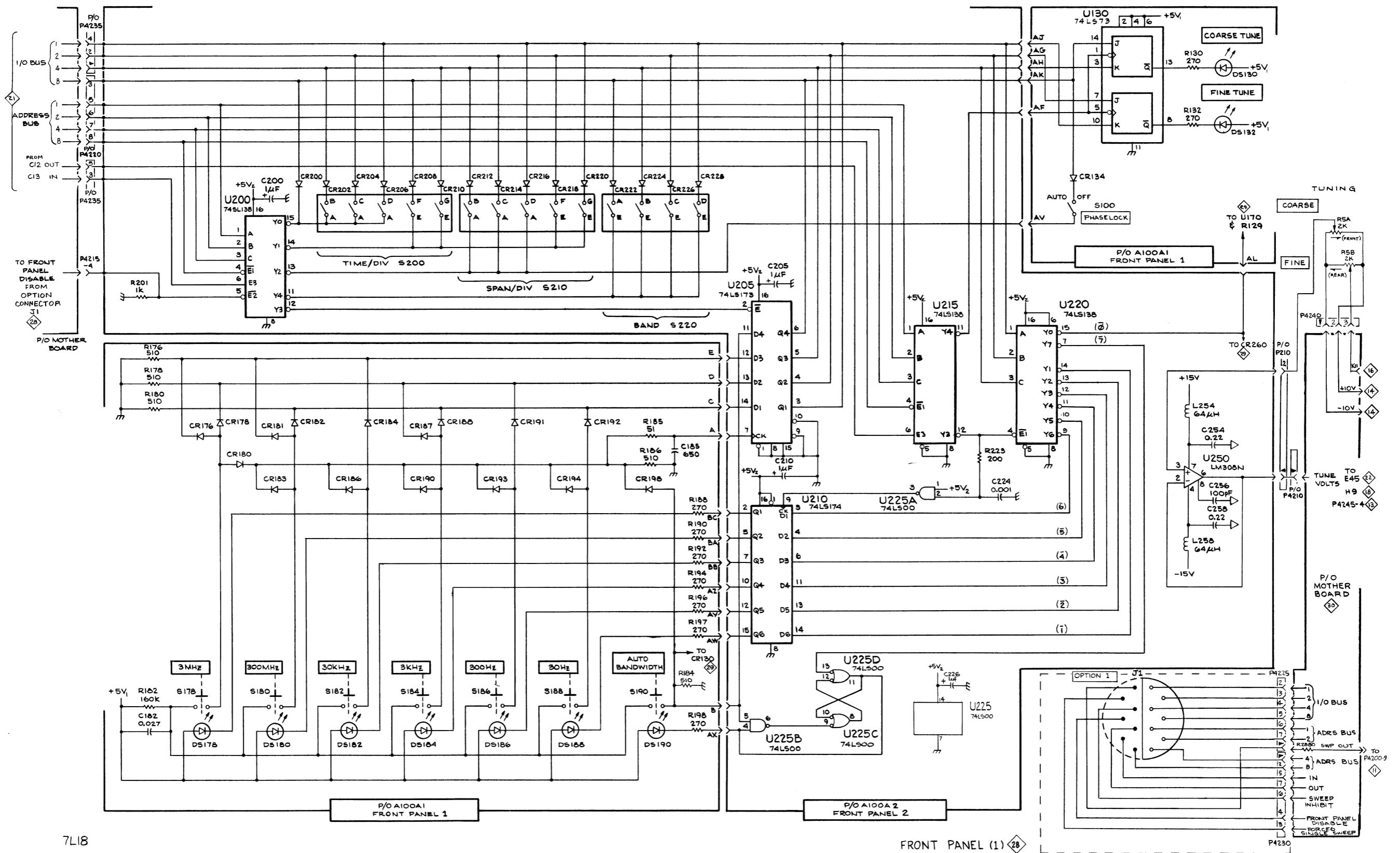

7L18

FRONT PANEL (1) 28

FRONT PANEL FUNCTIONS

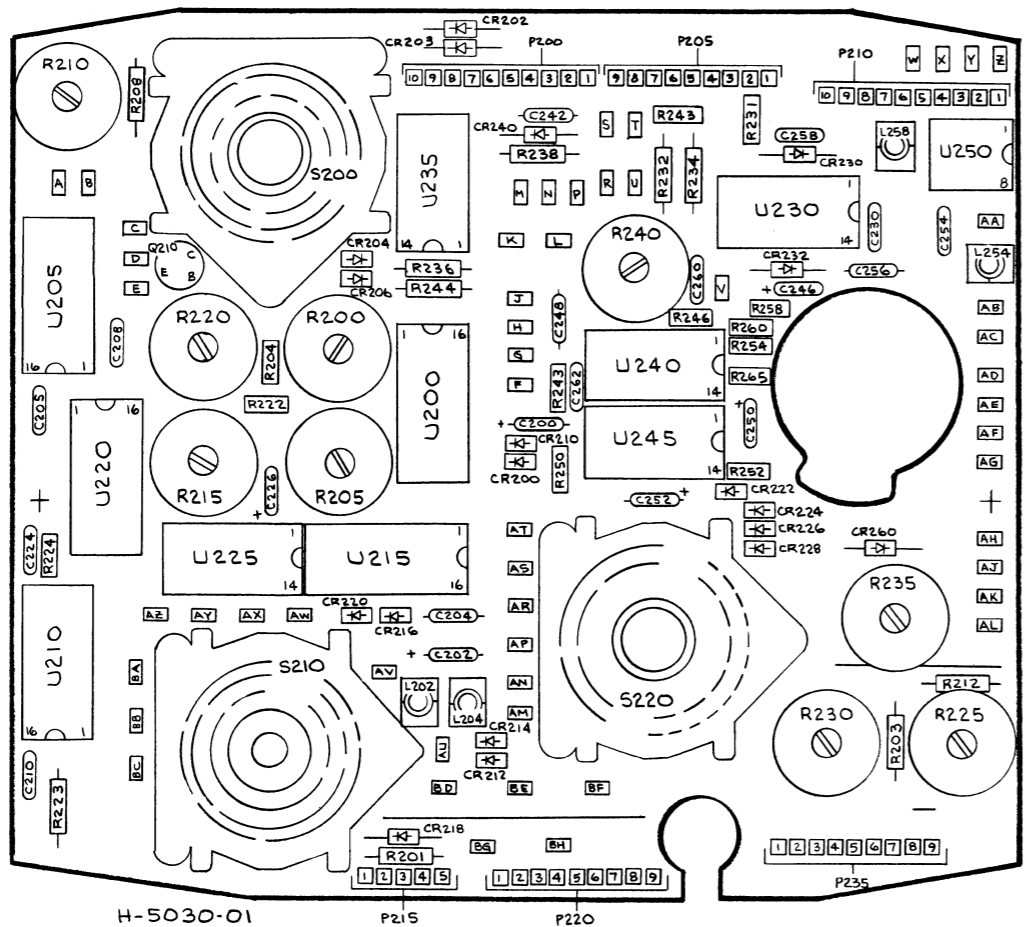

7L18 A100A2 FRONT PANEL BOARD # 2

FRONT PANEL #2

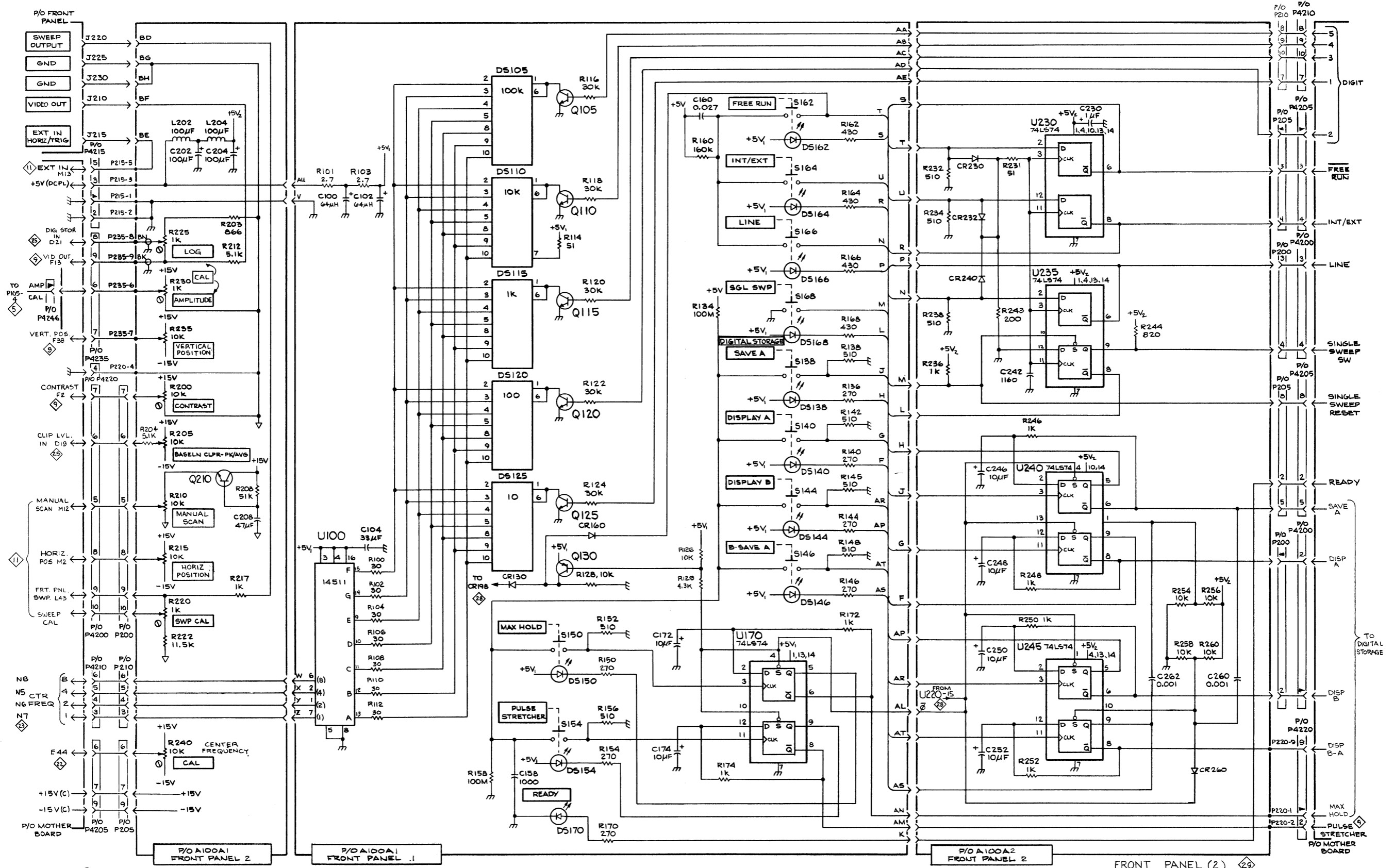

7L18

FRONT PANEL (2)

TO DIGITAL STORAGE

P/O MOTHER BOARD

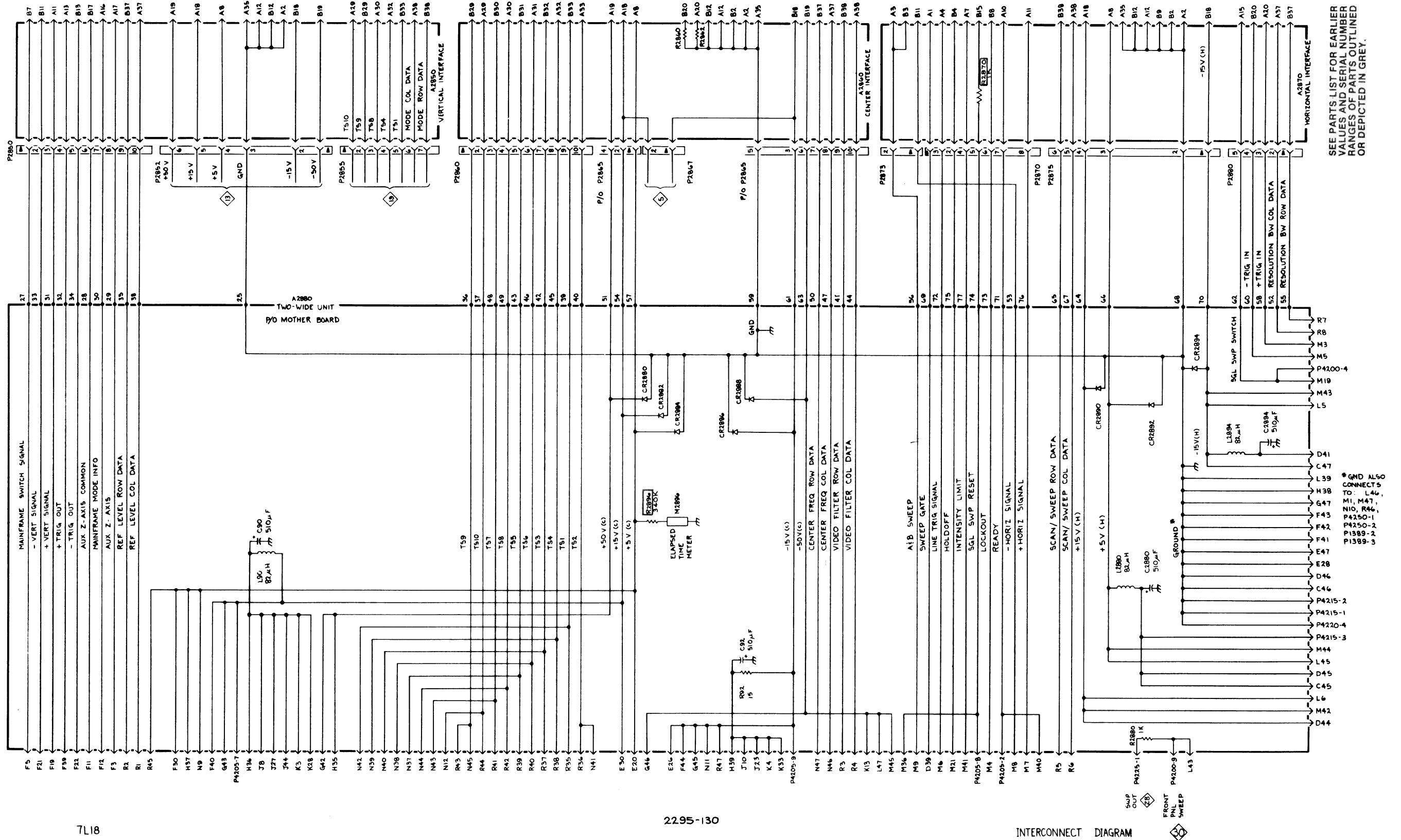

SEE PARTS LIST FOR EARLIER VALUES AND SERIAL NUMBER RANGES OF PARTS OUTLINED OR DEPICTED IN GREY.

* GND ALSO CONNECT TO:
 M10, M47, L46, M11, M47, R46, P4230-1, P4230-2, P4230-3, P4230-4, P4230-5

REPLACEABLE MECHANICAL PARTS

PARTS ORDERING INFORMATION

Replacement parts are available from or through your local Tektronix, Inc. Field Office or representative.

Changes to Tektronix instruments are sometimes made to accommodate improved components as they become available, and to give you the benefit of the latest circuit improvements developed in our engineering department. It is therefore important, when ordering parts, to include the following information in your order: Part number, instrument type or number, serial number, and modification number if applicable.

If a part you have ordered has been replaced with a new or improved part, your local Tektronix, Inc. Field Office or representative will contact you concerning any change in part number.

Change information, if any, is located at the rear of this manual.

SPECIAL NOTES AND SYMBOLS

X000 Part first added at this serial number
00X Part removed after this serial number

FIGURE AND INDEX NUMBERS

Items in this section are referenced by figure and index numbers to the illustrations.

INDENTATION SYSTEM

This mechanical parts list is indented to indicate item relationships. Following is an example of the indentation system used in the description column.

```

1 2 3 4 5           Name & Description
Assembly and/or Component
Attaching parts for Assembly and/or Component
    --- * ---
Detail Part of Assembly and/or Component
Attaching parts for Detail Part
    --- * ---
Parts of Detail Part
Attaching parts for Parts of Detail Part
    --- * ---
  
```

Attaching Parts always appear in the same indentation as the item it mounts, while the detail parts are indented to the right. Indented items are part of, and included with, the next higher indentation. The separation symbol --- * --- indicates the end of attaching parts.

Attaching parts must be purchased separately, unless otherwise specified.

ITEM NAME

In the Parts List, an Item Name is separated from the description by a colon (:). Because of space limitations, an Item Name may sometimes appear as incomplete. For further Item Name identification, the U.S. Federal Cataloging Handbook H6-1 can be utilized where possible.

ABBREVIATIONS

"	INCH	ELCTRN	ELECTRON	IN	INCH	SE	SINGLE END
#	NUMBER SIZE	ELEC	ELECTRICAL	INCAND	INCANDESCENT	SECT	SECTION
ACTR	ACTUATOR	ELCTLT	ELECTROLYTIC	INSUL	INSULATOR	SEMICOND	SEMICONDUCTOR
ADPTR	ADAPTER	ELEM	ELEMENT	INTL	INTERNAL	SHLD	SHIELD
ALIGN	ALIGNMENT	EPL	ELECTRICAL PARTS LIST	LPHLDR	LAMPHOLDER	SHLDR	SHOULDERED
AL	ALUMINUM	EQPT	EQUIPMENT	MACH	MACHINE	SKT	SOCKET
ASSEM	ASSEMBLED	EXT	EXTERNAL	MECH	MECHANICAL	SL	SLIDE
ASSY	ASSEMBLY	FIL	FILLISTER HEAD	MTG	MOUNTING	SLFLKG	SELF-LOCKING
ATTEN	ATTENUATOR	FLEX	FLEXIBLE	NIP	NIPPLE	SLVG	SLEEVING
AWG	AMERICAN WIRE GAGE	FLH	FLAT HEAD	NON WIRE	NOT WIRE WOUND	SPR	SPRING
BD	BOARD	FLTR	FILTER	OBD	ORDER BY DESCRIPTION	SQ	SQUARE
BRKT	BRACKET	FR	FRAME or FRONT	OD	OUTSIDE DIAMETER	SST	STAINLESS STEEL
BRS	BRASS	FSTNR	FASTENER	OVB	OVAL HEAD	STL	STEEL
BRZ	BRONZE	FT	FOOT	PH BRZ	PHOSPHOR BRONZE	SW	SWITCH
BSHG	BUSHING	FXD	FIXED	PL	PLAIN or PLATE	T	TUBE
CAB	CABINET	GSKT	GASKET	PLSTC	PLASTIC	TERM	TERMINAL
CAP	CAPACITOR	HDL	HANDLE	PN	PART NUMBER	THD	THREAD
CER	CERAMIC	HEX	HEXAGON	PNH	PAN HEAD	THK	THICK
CHAS	CHASSIS	HEX HD	HEXAGONAL HEAD	PWR	POWER	TNSN	TENSION
CKT	CIRCUIT	HEX SOC	HEXAGONAL SOCKET	RCPT	RECEPTACLE	TPG	TAPPING
COMP	COMPOSITION	HLCPS	HELICAL COMPRESSION	RES	RESISTOR	TRH	TRUSS HEAD
CONN	CONNECTOR	HLEXT	HELICAL EXTENSION	RGD	RIGID	V	VOLTAGE
COV	COVER	HV	HIGH VOLTAGE	RLF	RELIEF	VAR	VARIABLE
CPLG	COUPLING	IC	INTEGRATED CIRCUIT	RTNR	RETAINER	W/	WITH
CRT	CATHODE RAY TUBE	ID	INSIDE DIAMETER	SCH	SOCKET HEAD	WSHR	WASHER
DEG	DEGREE	IDNT	IDENTIFICATION	SCOPE	OSCILLOSCOPE	XFMR	TRANSFORMER
DWR	DRAWER	IMPLR	IMPELLER	SCR	SCREW	XSTR	TRANSISTOR

CROSS INDEX—MFR. CODE NUMBER TO MANUFACTURER

Mfr. Code	Manufacturer	Address	City, State, Zip
000AH	STANDARD PRESSED STEEL CO., UNBRAKO DIV.	8535 DICE ROAD	SANTA FE SPRINGS, CA 90670
000BK	STAUFFER SUPPLY	105 SE TAYLOR	PORTLAND, OR 97214
000CY	NORTHWEST FASTENER SALES, INC.	7923 SW CIRRUSS DRIVE	BEAVERTON, OR 97005
00779	AMP, INC.	P O BOX 3608	HARRISBURG, PA 17105
01295	TEXAS INSTRUMENTS, INC., SEMICONDUCTOR GROUP	P O BOX 5012, 13500 N CENTRAL EXPRESSWAY	DALLAS, TX 75222
05820	WAKEFIELD ENGINEERING, INC.	AUDUBON ROAD	WAKEFIELD, MA 01880
08261	SPECTRA-STRIP CORP.	7100 LAMPSON AVE.	GARDEN GROVE, CA 92642
12327	FREEWAY CORPORATION	9301 ALLEN DRIVE	CLEVELAND, OH 44125
12360	ALBANY PRODUCTS CO., DIV. OF PNEUMODYNAMICS CORPORATION	145 WOODWARD AVENUE	SOUTH NORWALK, CT 06586
13257	AMERACE, LTD.	10 ESNA PARK DRIVE	MARKHAM, ONTARIO, CANADA
18203	ENGELMANN MICROWAVE CO.	SKYLINE DR.	MONTVILLE, NJ 07045
22526	BERG ELECTRONICS, INC.	YOUNG EXPRESSWAY	NEW CUMBERLAND, PA 17070
22599	ESNA, DIV. OF AMERACE CORPORATION	16150 STAGG STREET	VAN NUYS, CA 91409
24931	SPECIALITY CONNECTOR CO., INC.	2620 ENDRESS PLACE	GREENWOOD, IN 46142
26365	GRIES REPRODUCER CO., DIV. OF COATS AND CLARK, INC.	125 BEECHWOOD AVE.	NEW ROCHELLE, NY 10802
26805	OMNI SPECTRA INC., MICROWAVE CONNECTOR DIV.	140 FOURTH AVE	WALTHAM, MA 02154
31223	MICRO PLASTICS, INC.	20821 DEARBORN STREET	CHATSWORTH, CA 91311
45722	USM CORP., PARKER-KALON FASTENER DIV.		CAMPBELLSVILLE, KY 42718
49671	RCA CORPORATION	30 ROCKEFELLER PLAZA	NEW YORK, NY 10020
55210	GETTIG ENG. AND MFG. COMPANY	PO BOX 85, OFF ROUTE 45	SPRING MILLS, PA 16875
70276	ALLEN MFG. CO.	P. O. DRAWER 570	HARTFORD, CT 06101
71279	CAMBRIDGE THERMIONIC CORP.	445 CONCORD AVE.	CAMBRIDGE, MA 02138
71785	TRW, CINCH CONNECTORS	1501 MORSE AVENUE	ELK GROVE VILLAGE, IL 60007
73743	FISCHER SPECIAL MFG. CO.	446 MORGAN ST.	CINCINNATI, OH 45206
73803	TEXAS INSTRUMENTS, INC., METALLURGICAL MATERIALS DIV.	34 FOREST STREET	ATTLEBORO, MA 02703
74445	HOLO-KROME CO.	31 BROOK ST. WEST	HARTFORD, CT 06110
74921	ITEN FIBRE CO.,	4001 BENEFIT AVE., P O BOX 9	ASHTABULA, OH 44004
77250	PHEOLL MANUFACTURING CO., DIVISION OF ALLIED PRODUCTS CORP.	5700 W. ROOSEVELT RD.	CHICAGO, IL 60650
79136	WALDES, KOHINOOR, INC.	47-16 AUSTEL PLACE	LONG ISLAND CITY, NY 11101
80009	TEKTRONIX, INC.	P O BOX 500	BEAVERTON, OR 97077
83309	ELECTRICAL SPECIALITY CO., SUBSIDIARY OF BELDEN CORP.	213 E. HARRIS AVE. SOUTH	SAN FRANCISCO, CA 94080
83330	SMITH, HERMAN H., INC.	812 SNEDIKER AVE.	BROOKLYN, NY 11207
83385	CENTRAL SCREW CO.	2530 CRESCENT DR.	BROADVIEW, IL 60153
86928	SEASTROM MFG. COMPANY, INC.	701 SONORA AVENUE	GLENDALE, CA 91201
87308	N. L. INDUSTRIES, INC., SOUTHERN SCREW DIV.	P. O. BOX 1360	STATESVILLE, NC 28677
91836	KINGS ELECTRONICS CO., INC.	40 MARBLEDALE ROAD	TUCKAHOE, NY 10707
93907	TEXTRON INC. CAMCAR DIV	600 18TH AVE	ROCKFORD, IL 61101
98159	RUBBER TECK, INC.	19115 HAMILTON AVE., P O BOX 389	GARDENA, CA 90247
98291	SEAELECTRO CORP.	225 HOYT	MAMARONECK, NY 10544

Replaceable Mechanical Parts—7L18 Service

Fig. & Index No.	Tektronix Part No.	Serial/Model No.		Qty	1 2 3 4 5	Name & Description	Mfr	
		Eff	Dscont				Code	Mfr Part Number
1-1	366-1727-00			1		KNOB:GRAY,0.127 ID X 0.706 OD X 0.614	80009	366-1727-00
	213-0153-00			1		. SETSCREW:5-40 X 0.125,STL BK OXD,HEX SKT	000CY	OBD
-2	366-1716-00	B010100	B010399	1		KNOB:GRAY,0.874 ID X 1.396 OD X 0.714	80009	366-1716-01
	366-1716-01	B010400		1		KNOB:GY,0.874 ID X 1.396 OD X 0.7 H	80009	366-1716-01
	213-0048-00			2		. SETSCREW:4-40 X 0.125 INCH,HEX SOC STL	74445	OBD
-3	401-0361-00			1		GEAR,INTERNAL:80 TOOTH,DELTRIN	80009	401-0361-00
-4	214-2742-00	XB010400		1		SPRING,HLEXT:0.088 OD X 1.246 L XLOOP	80009	214-2742-00
-5	401-0362-00	B010100	B010399	1		GEAR,SPUR:80 TOOTH,PLASTIC	80009	401-0362-01
	401-0362-01	B010400		1		GEAR,SPUR:80 TOOTH,PLASTIC	80009	401-0362-01
						(ATTACHING PARTS)		
-6	213-0153-00			2		SETSCREW:5-40 X 0.125,STL BK OXD,HEX SKT	000CY	OBD
						- - - * - - -		
-7	432-0116-00	B010100	B010399	1		BASE,KNOB:0.65 ID X 1.187 OD,PLASTIC	80009	432-0116-01
	432-0116-01	B010400		1		BASE,KNOB:0.65 ID X 0.44 THK,PLASTIC	80009	432-0116-01
						(ATTACHING PARTS)		
-8	210-1264-00			1		NUT,SHOULDER:0.375 ID X 0.641 OD,BRS	80009	210-1264-00
-9	210-1271-00			1		WASHER,FLAT:0.453 ID X 0.644 OD,BRS	80009	210-1271-00
						- - - * - - -		
-10	210-1260-00			1		WASHER,SPR TNSN:0.856 ID	86928	5806-65-2
-11	210-1284-00	XB010400		1		WASHER,FLAT:0.45 ID X 1.10 OD,TEFLON	86928	A362-117-110
-12	358-0301-00	B010100	B020632	5		BUSHING,SLEEVE:FOR 0.185 DIA HOLE,GRAY	80009	358-0301-00
	358-0301-03	B020633		5		BUSHING,SLEEVE:0.16 ID X 0.125 L,GY DELTRIN	80009	358-0301-03
-13	366-1190-00			1		KNOB:GRAY	80009	366-1190-00
	213-0153-00			2		. SETSCREW:5-40 X 0.125,STL BK OXD,HEX SKT	000CY	OBD
-14	200-2054-00			1		COVER,HOLE:BRASS	80009	200-2054-00
						(ATTACHING PARTS)		
-15	210-0410-00			1		NUT,PLAIN,HEX.:10-32 X 0.312 INCH,BRS	73743	2X20003-402
-16	210-1182-00			1		WSHR,SPR TNSN:0.218 ID X 0.69 INCH OD	80009	210-1182-00
						- - - * - - -		
-17	366-1030-00			2		KNOB:ASSEMBLY	80009	366-1030-00
	-----			-		EACH KNOB INCLUDES:		
	213-0153-00			2		. SETSCREW:5-40 X 0.125,STL BK OXD,HEX SKT	000CY	OBD
-18	366-1389-00			3		KNOB:GRAY	80009	366-1389-00
	-----			-		EACH KNOB INCLUDES:		
	213-0306-00			1		. SETSCREW:2-56 X 0.062 INCH,OX STL	74445	OBD
-19	366-1540-00			1		KNOB:GRAY	80009	366-1540-00
	213-0140-00			2		. SETSCREW:2-56 X 0.94 INCH,HEX SOC STL	70276	OBD
-20	366-1058-72			1		KNOB:GRAY	80009	366-1058-72
						(ATTACHING PARTS)		
-21	214-1095-00			1		PIN,SPG,SPLIT:0.094 OD X 0.187 INCH LONG	22599	52-022-094-0187
						- - - * - - -		
-22	333-2181-00	B010100	B020799	1		PANEL,FRONT:	80009	333-2181-00
	333-2181-01	B020800		1		PANEL,FRONT:	80009	333-2181-01
-23	343-0640-00			1		RTNR,LIGHT FLTR:CTR FREQ READOUT,ABX,BLACK	80009	343-0640-00
-24	378-0854-00	B010100	B020399	1		FILTER,LIGHT:1.495 L X 0.56 W,RED	80009	378-0854-00
	378-0854-01	B020400		1		FILTER,LIFHT:1.495 L X 0.56 W,RED	80009	378-0854-01
-25	378-0855-00			1		LENS,BAND SW:CLEAR	80009	378-0855-00
-26	214-2617-00			5		SPRING,GROUND:0.248 ID,COPPER BERYLLIUM	80009	214-2617-00
-27	136-0387-00			5		JACK,TIP:GRAY	71279	450-4352-01-0318
	342-0453-00	B010100	B020449X	1		INSULATOR,FILM:CKT BD,POLYESTER	80009	342-0453-00
	342-0454-00	B010100	B020449X	1		INSULATOR,FILM:CKT BD,POLYESTER	80009	342-0454-00
-28	131-0787-00			5		CONTACT,ELEC:0.64 INCH LONG	22526	47359
-29	376-0180-00			5		CPLG,SHAFT,RGD:0.042 ID X 0.052,BRASS	80009	376-0180-00
-30	351-0496-00			1		GUIDE,PLUG-IN:TOP LEFT	80009	351-0496-00
						(ATTACHING PARTS)		
-31	211-0007-00			1		SCREW,MACHINE:4-40 X 0.188 INCH,PNH STL	83385	OBD
-32	211-0531-00			2		SCREW,MACHINE:6-32 X 0.375,FIL,STL	83385	OBD
						- - - * - - -		
-33	351-0497-00			1		GUIDE,PLUG-IN:LOWR LEFT	80009	351-0497-00
						(ATTACHING PARTS)		
-34	211-0007-00			1		SCREW,MACHINE:4-40 X 0.188 INCH,PNH STL	83385	OBD
-35	211-0531-00			2		SCREW,MACHINE:6-32 X 0.375,FIL,STL	83385	OBD
						- - - * - - -		
-36	214-1054-02			1		SPRING,DETENT:LATCH	80009	214-1054-02
-37	105-0076-00			1		REL BAR,LATCH:PLUG-IN UNIT	80009	105-0076-00

Replaceable Mechanical Parts—7L18 Service

Fig. & Index No.	Tektronix Part No.	Serial/Model No. Eff Dscont	Qty	1	2	3	4	5	Name & Description	Mfr Code	Mfr Part Number
1-38	105-0075-00		1						BOLT, LATCH: 7A & 7B SER PL-IN	80009	105-0075-00
-39	214-1280-00		1						SPRING, HLCPS: 0.14 OD X 1.126" L, 0.16" DIA W	80009	214-1280-00
-40	214-2462-00		1						HEAT SINK, XSTR: TOP RIGHT (ATTACHING PARTS)	80009	214-2462-00
-41	211-0531-00		2						SCREW, MACHINE: 6-32 X 0.375, FIL, STL - - - * - - -	83385	OBD
-42	214-2463-00		1						HINGE BLOCK: LOWER RIGHT (ATTACHING PARTS)	80009	214-2463-00
-43	211-0507-00		1						SCREW, MACHINE: 6-32 X 0.312 INCH, PNH STL	83385	OBD
-44	211-0531-00		1						SCREW, MACHINE: 6-32 X 0.375, FIL, STL	83385	OBD
-45	211-0038-00		1						SCREW, MACHINE: 4-40 X 0.312, FLH, 100 DEG	83385	OBD
-46	401-0237-00		1						BEARING, SLEEVE: 0.125 ID X 0.23 L, SST - - - * - - -	80009	401-0237-00
	672-0590-00		1						CKT BOARD ASYS: FRONT PANEL #2 (ATTACHING PARTS)	80009	672-0590-00
-47	211-0081-00		4						SCREW, MACHINE: 2-56 X 0.562, PNH STL - - - * - - -	83385	OBD
-48	-----		-						CKT BOARD ASSY INCLUDES: 1 . CKT BOARD ASSY: FR PANEL POT (SEE A100A2A1 REPL)		
	198-3538-00		1						. . WIRE KIT, ELEC:	22526	75691-005
-49	131-0707-00		23						. . . CONNECTOR, TERM: 22-26 AWG, BRS& CU BE GOLD	22526	47439
-50	352-0167-00		1						. . . HLD, TERM CONN: 9 WIRE BLACK	80009	352-0167-00
	352-0167-07		1						. . . CONN BODY, PL, EL: 9 WIRE VIOLET	80009	352-0167-07
-51	352-0163-06		1						. . . CONN BODY, PL, EL: 5 WIRE BLUE	80009	352-0163-06
-52	175-0832-00		FT						. . . WIRE, ELECTRICAL: 9 WIRE RIBBON	08261	SS-0926(1061)0C
-53	175-0830-00		FT						. . . WIRE, ELECTRICAL: 7 WIRE RIBBON	08261	SS-0726-710610C
-54	175-0828-00		FT						. . . WIRE, ELECTRICAL: 5 WIRE RIBBON	08261	SS-0526-710610C
-55	136-0514-00		1						. . SKT, PL-IN ELEC: MICROCIRCUIT, 8 DIP	73803	CS9002-8
-56	136-0260-02		5						. . SKT, PL-IN ELEC: MICROCIRCUIT, 16 DIP, LOW CLE	71785	133-51-92-008
-57	136-0263-04		54						. . SOCKET, PIN TERM: FOR 0.025 INCH SQUARE PIN	22526	75377-001
-58	131-0608-00		29						. . TERMINAL, PIN: 0.365 L X 0.025 PH BRZ GOLD	22526	47357
-59	136-0252-07	B010100 B020499X	3						. . SOCKET, PIN CONN: W/O DIMPLE	22526	75060-012
-60	352-0495-00	B010100 B010100X	3						. . HOLDER, WIRE: STRIN RELIEF, VINYL	80009	352-0495-00
-61	136-0269-02		5						. . SKT, PL-IN ELEC: MICROCIRCUIT, 14 DIP, LOW CLE	73803	CS9002-14
-62	361-0788-00		4						. . SPACER, SLEEVE: 0.431 L X 0.113, BRASS	80009	361-0788-00
	-----		1						. SW ROTARY, ASSY: (SEE S220 REPL)		
-63	401-0341-01		1						. . BEARING, RTRY SW: REAR, 0.252 ID	80009	401-0341-01
-64	352-0457-01		1						. . HOLDER, CONTACT: 1 CONTACT, GRAY	80009	352-0457-01
-65	352-0457-05		1						. . HOLDER, CONTACT: 1 CONTACT	80009	352-0457-05
-66	384-1432-02		1						. . SHAFT, ROTARY SW: W/DETENT, 28 POSN, 23 STOPS	80009	384-1432-02
-67	401-0340-01		1						. . BEARING, RTRY SW: FRONT, 0.375 DIA	80009	401-0340-01
-68	214-1127-00		2						. . ROLLER, DETENT: 0.125 DIA X 0.125, SST	80009	214-1127-00
-69	214-1126-01		2						. . SPRING, FLAT: 0.7 X 0.125, CU BE GRN CLR	80009	214-1126-01
-70	210-0053-00		3						. . WASHER, LOCK: INTL, 0.092 ID X 0.175" OD, STL	83385	OBD
-71	213-0759-00		3						. . SCR, TPG, THD FOR: 2-28 X 0.437 INCH, PNH, STL	93907	OBD
	-----		1						. SW ROTARY, ASSY: (SEE S210 REPL)		
-72	401-0341-01		1						. . BEARING, RTRY SW: REAR, 0.252 ID	80009	401-0341-01
-73	352-0457-01		1						. . HOLDER, CONTACT: 1 CONTACT, GRAY	80009	352-0457-01
-74	352-0457-05		1						. . HOLDER, CONTACT: 1 CONTACT	80009	352-0457-05
-75	384-1432-01		1						. . SHAFT, ROTARY SW: W/DETENT, 28 POSN, 26 STOPS	80009	384-1432-01
-76	401-0340-01		1						. . BEARING, RTRY SW: FRONT, 0.375 DIA	80009	401-0340-01
-77	214-1126-01		2						. . SPRING, FLAT: 0.7 X 0.125, CU BE GRN CLR	80009	214-1126-01
-78	214-1127-00		2						. . ROLLER, DETENT: 0.125 DIA X 0.125, SST	80009	214-1127-00
-79	213-0759-00		3						. . SCR, TPG, THD FOR: 2-28 X 0.437 INCH, PNH, STL	93907	OBD
-80	210-0053-00		3						. . WASHER, LOCK: INTL, 0.092 ID X 0.175" OD, STL	83385	OBD
	-----		1						. SW ROTARY, ASSY: (SEE S200 REPL)		
-81	401-0341-01		1						. . BEARING, RTRY SW: REAR, 0.252 ID	80009	401-0341-01
-82	352-0457-03		1						. . HOLDER, CONTACT: 2 CONTACT, GRAY	80009	352-0457-03
-83	384-1432-03		1						. . SHAFT, ROTARY SW: W/DETENT, 28 POSN, 12 STOPS	80009	384-1432-03
-84	401-0340-01		1						. . BEARING, RTRY SW: FRONT, 0.375 DIA	80009	401-0340-01
-85	214-1127-00		2						. . ROLLER, DETENT: 0.125 DIA X 0.125, SST	80009	214-1127-00
-86	214-1126-01		2						. . SPRING, FLAT: 0.7 X 0.125, CU BE GRN CLR	80009	214-1126-01
-87	210-0053-00		3						. . WASHER, LOCK: INTL, 0.092 ID X 0.175" OD, STL	83385	OBD
-88	213-0759-00		3						. . SCR, TPG, THD FOR: 2-28 X 0.437 INCH, PNH, STL	93907	OBD
-89	342-0454-00	B010100 B020449	1						INSULATOR, FILM: CKT BD POLYESTER	80009	342-0454-00

Replaceable Mechanical Parts—7L18 Service

Fig. & Index No.	Tektronix Part No.	Serial/Model No. Eff	Dscont	Qty	1	2	3	4	5	Name & Description	Mfr Code	Mfr Part Number
1-90	342-0453-00	B010100	B020449	1						INSULATOR, FILM:CKT BD POLYESTER	80009	342-0453-00
-91	-----			1						CKT BOARD ASSY:FRONT PANEL(SEE A100A1 REPL)		
-92	131-0590-00			49						. CONTACT,ELEC:0.71 INCH LONG	22526	47351
-93	136-0252-04	B010100	B020450X	16						. SOCKET,PIN TERM:U/W 0.016-0.018 DIA PINS	22526	75060-007
-94	136-0269-02			1						. SKT,PL-IN ELEK:MICROCIRCUIT,14 DIP,LOW CLE	73803	CS9002-14
-95	131-2193-00	B010100	B020450X	34						. TERMINAL,PIN:BRASS	80009	131-2193-00
-96	-----			17						SWITCH PB ASSY:(SEE S138,140,144,146,150,154, S162,164,166,168,178,180,182,184,186,188,190, REPL)		
-97	348-0235-00			2						SHLD GSKT,ELEC:4.734 INCH LONG	80009	348-0235-00
-98	386-1858-10			1						SUBPANEL,FRONT:	80009	386-1858-10
-99	214-2616-00			2						CONTACT,ELEC:GROUNDING CU BE	80009	214-2616-00
-100	354-0392-00			2						RING,RETAINING:	79136	5555-12MD
-101	210-1011-00			2						WASHER,NONMETAL:0.13 ID X 0.375 " OD,PLSTC	83309	OBD
-102	401-0130-00			1						PULLEY,GROOVE:0.71 OD,W/0.700 GROOVE,BRASS (ATTACHING PARTS)	80009	401-0130-00
-103	213-0022-00			2						SETSCREW:4-40 X 0.188 INCH,HEX SOC STL	74445	OBD
-104	214-1601-00			1						PIN,WIRE TAKE-U:PULLEY ASSEMBLY	80009	214-1601-00
-105	354-0430-00			1						RING,LOCKING:ATTENUATOR	80009	354-0430-00
-106	342-0380-00			1						INSUL,WASHER:0.25 ID X 0.715 OD,PLASTIC	80009	342-0380-00
-107	210-0992-00			2						WASHER,FLAT:0.265 ID X 0.01 THK,TEFLON	80009	210-0992-00
-108	384-1434-00			1						SHAFT,PULLY:IDLER (ATTACHING PARTS)	80009	384-1434-00
-109	354-0350-00			1						RING,RETAINING:0.073"FREE ID X 0.015",STL	79136	5133-9MD
-110	401-0357-00			2						PULLEY,FLAT:BAND SWITCH	80009	401-0357-00
-111	384-1438-00			1						SHAFT,BAND SW:0.132 ID X 0.248 OD,BRASS	80009	384-1438-00
-112	354-0219-00			1						RING,RETAINING:FOR 0.25 INCH SHAFT	79136	5103-25-MD-R
-113	-----			1						RESISTOR,VAR:(SEE R5A AND R5B REPL)		
-114	386-3576-00			2						SUPPORT,DIAL:	80009	386-3576-00
-115	384-1437-00			2						SHAFT,IDLER:0.125 OD X 0.375 INCH LONG	80009	384-1437-00
	334-2868-00			1						MARKER,IDENT:MKD INPUT	80009	334-2868-00
-116	175-0947-01			1						CABLE,DIAL:9.0 L,5 PER PACKAGE	80009	175-0947-01
-117	331-0417-00			1						DIAL,BAND SW: (ATTACHING PARTS)	80009	331-0417-00
	354-0350-00			2						RING,RETAINING:0.073"FREE ID X 0.015",STL	79136	5133-9MD
	198-3135-00			1						WIRE KIT,ELEC:FRONT PANEL ASSEMBLY	80009	198-3135-00
-118	131-0707-00			2						. CONNECTOR,TERM:22-26 AWG,BRS& CU BE GOLD	22526	47439
-119	352-0168-00			2						. CONN BODY,PL,EL:10 WIRE BLACK	80009	352-0168-00
	352-0168-03			3						. CONN BODY,PL,EL:10 WIRE ORANGE	80009	352-0168-03
-120	352-0167-02			2						. CONN BODY,PL,EL:9 WIRE RED	80009	352-0167-02
-121	352-0161-04			1						. CONN BODY,PL,EL:3 WIRE YELLOW	80009	352-0161-04
-122	175-0833-00			FT						. WIRE,ELECTRICAL:10 WIRE RIBBON	08261	SS-1026-7
-123	175-0832-00			FT						. WIRE,ELECTRICAL:9 WIRE RIBBON	08261	SS-0926(1061)OC
-124	175-0826-00			FT						. WIRE,ELECTRICAL:3 WIRE RIBBON	80009	175-0826-00
-125	200-1990-00			1						COVER,CKT BOARD:VAR RESOLUTION (ATTACHING PARTS)	80009	200-1990-00
-126	211-0087-01			23						SCREW,MACHINE:2-56 X 0.188,FLH 82 DEG,STL	83385	OBD
-127	131-0593-00			4						CONTACT,ELEC:1.15 INCH LONG	22526	47354
-128	-----			1						CKT BOARD ASSY:POST VR AMP(SEE A3000A5 REPL) (ATTACHING PARTS)		
-129	211-0007-00			4						SCREW,MACHINE:4-40 X 0.188 INCH,PNH STL	83385	OBD
	-----			-						CKT BOARD ASSY INCLUDES:		
-130	136-0263-04			10						. SOCKET,PIN TERM:FOR 0.025 INCH SQUARE PIN	22526	75377-001
-131	136-0252-04	B010100	B020499X	6						. SOCKET,PIN TERM:U/W 0.016-0.018 DIA PINS	22526	75060-007
-132	-----			1						CKT BOARD ASSY:300KHZ FILTER(SEE A3000A4 REPL) (ATTACHING PARTS)		
-133	211-0007-00			3						SCREW,MACHINE:4-40 X 0.188 INCH,PNH STL	83385	OBD
	-----			-						CKT BOARD ASSY INCLUDES:		
-134	136-0263-04			2						. SOCKET,PIN TERM:FOR 0.025 INCH SQUARE PIN	22526	75377-001

Replaceable Mechanical Parts—7L18 Service

Fig. & Index No.	Tektronix Part No.	Serial/Model No. Eff Dscont	Qty	1	2	3	4	5	Name & Description	Mfr Code	Mfr Part Number
1-135	214-1611-00		2						HEAT SINK,ELEC:0.280 ID,W/ 4-40 THREADS (ATTACHING PARTS)	05820	260-4T5E-C4631
-136	211-0105-00		2						SCREW,MACHINE:4-40 X 0.188,100 DEG,FLH STL	83385	OBD
-137	-----		1						CKT BOARD ASSY:VR AMPLIFIER(SEE A3000A3 REPL) (ATTACHING PARTS)		
-138	211-0007-00		5						SCREW,MACHINE:4-40 X 0.188 INCH,PNH STL	83385	OBD
-139	214-0579-00		-						CKT BOARD ASSY INCLUDES:		
-140	136-0263-04		11						. TERM,TEST POINT:BRS CD PL	80009	214-0579-00
-141	136-0252-04	B010100 B020499X	9						. SOCKET,PIN TERM:FOR 0.025 INCH SQUARE PIN	22526	75377-001
-142	346-0152-00		2						STRAP,RETAINING:FILTER,SST (ATTACHING PARTS FOR EACH)	80009	346-0152-00
-143	211-0237-00		2						SCREW,CAP:2-56 X 0.25,HEX SOC,STL,CD PL	000CY	OBD
-144	210-0053-00	B010100 B020449	2						WASHER,LOCK:INTL,0.092 ID X 0.175"OD,STL	83385	OBD
	210-0053-00	B020450	4						WASHER,LOCK:INTL,0.092 ID X 0.175"OD,STL	83385	OBD
	131-2517-00	XB020450	1						CONTACT,ELEC:GROUNDING,CU BE,CU TIN ZN	80009	131-2517-00
-145	-----		1						CKT BOARD ASSY:VR PREAMP(SEE A3000A2 REPL) (ATTACHING PARTS)		
-146	211-0007-00		4						SCREW,MACHINE:4-40 X 0.188 INCH,PNH STL	83385	OBD
-147	136-0252-04	B010100 B020499X	25						. SOCKET,PIN TERM:U/W 0.016-0.018 DIA PINS	22526	75060-007
-148	214-0579-00		2						. TERM,TEST POINT:BRS CD PL	80009	214-0579-00
-149	136-0263-04		6						. SOCKET,PIN TERM:FOR 0.025 INCH SQUARE PIN	22526	75377-001
-150	337-2434-00		1						SHIELD,ELEC:VR INPUT	80009	337-2434-00
-151	342-0364-00		2						INSULATOR,PLATE:TRANSISTOR SOCKET,PLASTIC	80009	342-0364-00
-152	-----		1						CKT BOARD ASSY:VR INPUT(SEE A3000A1 REPL) (ATTACHING PARTS)		
-153	211-0007-00		3						SCREW,MACHINE:4-40 X 0.188 INCH,PNH STL	83385	OBD
-154	136-0252-04	B010100 B020499X	8						. SOCKET,PIN TERM:U/W 0.016-0.018 DIA PINS	22526	75060-007
-155	136-0263-04		6						. SOCKET,PIN TERM:FOR 0.025 INCH SQUARE PIN	22526	75377-001
-156	214-0579-00		2						. TERM,TEST POINT:BRS CD PL	80009	214-0579-00
-157	407-1825-00		1						BRKT,VERT SECT: (ATTACHING PARTS)	80009	407-1825-00
-158	211-0008-00		5						SCREW,MACHINE:4-40 X 0.25 INCH,PNH STL	83385	OBD
-159	211-0112-00		10						SCREW,MACHINE:2-56 X 0.375,FLH,100 DEG	83385	OBD
-160	-----		1						CKT BOARD ASSY:VR MOTHER(SEE A3000A6 REPL) (ATTACHING PARTS)		
-161	211-0180-00		13						SCR,ASSEM WSHR:2-56 X 0.25 INCH,PNH BRS	83385	OBD
-162	136-0252-04	B010100 B020499X	9						. SOCKET,PIN TERM:U/W 0.016-0.018 DIA PINS	22526	75060-007
-163	136-0260-02		1						. SKT,PL-IN ELEK:MICROCIRCUIT,16 DIP,LOW CLE	71785	133-51-92-008
-164	131-0787-00		27						. CONTACT,ELEC:0.64 INCH LONG	22526	47359
-165	131-0608-00		14						. TERMINAL,PIN:0.365 L X 0.025 PH BRZ GOLD	22526	47357
-166	131-0993-00		1						BUS,CONDUCTOR:2 WIRE BLACK	00779	530153-2
-167	131-1971-00		4						CONN,RCPT,ELEC:SNAP CATCH,STRAIGHT	98291	51-045-0459
-168	131-1972-00		3						CONN,RCPT,ELEC:SNAP CATCH,RIGHT ANGLE	98291	51-047-0239
-169	-----		1						CABLE ASSY,RF:(SEE W2484 REPL)		
-170	380-0489-01		1						HSG,ELEC SHIELD:W/CONNECTOR,ALUMINUM	80009	380-0489-01
	105-0404-03		1						SPRITE,CATCH:W/SPRING & HARDWARE (ATTACHING PARTS)	80009	105-0404-03
-171	211-0097-00		1						SCREW,MACHINE:4-40 X 0.312 INCH,PNH STL	83385	OBD
-172	210-1002-00		1						WASHER,FLAT:0.125 ID X 0.25 INCH OD,BRS	12327	OBD
-173	214-2634-00		1						LATCH ASSY INCLUDES:		
									. SPRING,LATCH:STAINLESS STEEL (ATTACHING PARTS)	80009	214-2634-00
-174	211-0005-00		1						. SCREW,MACHINE:4-40 X 0.125 INCH,PNH STL	83385	OBD
-175	211-0008-00		1						. SCREW,MACHINE:4-40 X 0.25 INCH,PNH STL	83385	OBD

Replaceable Mechanical Parts—7L18 Service

Fig. & Index No.	Tektronix Part No.	Serial/Model No. Eff Dscont	Qty	1	2	3	4	5	Name & Description	Mfr Code	Mfr Part Number
1-176	105-0404-02		1	.					SPRIKE, CATCH:	80009	105-0404-02
-177	200-2124-00		1						COVER, PLUG-IN:	80009	200-2124-00
									(ATTACHING PARTS)		
-178	213-0743-00		23						SCREW, TPG, TF:4-40 X 0.75 INCH, HEX SKT	83385	OBD
									- - - * - - -		
-179	426-1323-00		1						FRAME SECT, CAB:LOWER RIGHT	80009	426-1323-00
									(ATTACHING PARTS)		
-180	211-0225-00		1						SCR, CAP, SOC HD:4-40 X 0.312 INCH, STL	000AH	OBD
-181	213-0744-00		1						SCREW, TPG, TF:4-40 X 0.5 INCH, HEX SKT	83385	OBD
									- - - * - - -		
-182	-----		1						CKT BOARD ASSY:MOTHER(SEE A2880 REPL)		
									(ATTACHING PARTS)		
-183	213-0744-00		21						SCREW, TPG, TF:4-40 X 0.5 INCH, HEX SKT	83385	OBD
									- - - * - - -		
			-						CKT BOARD ASSY INCLUDES:		
-184	131-1931-00		2						CONN, RCPT, ELEC:SNAP CPLG, R ANGLE		
-185	136-0234-00		23						SOCKET, PIN TERM:0.088 OD X 0.247 INCH L	00779	380598-1
-186	131-1425-00		1						CONTACT SET, ELE:R ANGLE, 0.150" L, STR OF 36	22526	65521-136
-187	131-0608-00		71						TERMINAL, PIN:0.365 L X 0.025 PH BRZ GOLD	22526	47357
-188	131-0787-00		229						CONTACT, ELEC:0.64 INCH LONG	22526	47359
	198-3134-00		1						WIRE KIT, ELEC:MOTHER BOARD	80009	198-3134-00
-189	175-0825-00		FT						WIRE, ELECTRICAL:2 WIRE RIBBON	80009	175-0825-00
-190	175-0827-00		FT						CABLE, SP, ELEC:4, 26 AWG, STRD, PVC JKT, RBN	08261	SS04267(1061)OC
-191	175-0828-00		FT						WIRE, ELECTRICAL:5 WIRE RIBBON	08261	SS-0526-71061OC
-192	175-0829-00		FT						WIRE, ELECTRICAL:6 WIRE RIBBON	08261	SS-0626-71061OC
-193	175-0831-00		FT						WIRE, ELECTRICAL:8 WIRE RIBBON	08261	SS-0826-71061OC
-194	175-0833-00		FT						WIRE, ELECTRICAL:10 WIRE RIBBON	08261	SS-1026-7
-195	131-0707-00		77						CONNECTOR, TERM:22-26 AWG, BRS& CU BE GOLD	22526	47439
-196	352-0169-06		2						CONN BODY, PL, EL:2 WIRE BLUE	80009	352-0169-06
-197	352-0162-08		1						CONN BODY, PL, EL:4 WIRE GRAY	80009	352-0162-08
-198	352-0163-01		1						CONN BODY, PL, EL:5 WIRE BROWN	80009	352-0163-01
-199	352-0164-04		1						CONN BODY, PL, EL:6 WIRE YELLOW	80009	352-0164-04
-200	352-0166-06		1						CONN BODY, PL, EL:8 WIRE BLUE	80009	352-0166-06
-201	352-0168-00		1						CONN BODY, PL, EL:10 WIRE BLACK	80009	352-0168-00
	352-0168-02		1						CONN BODY, PL, EL:10 WIRE RED	80009	352-0168-02
	352-0168-03		1						CONN BODY, PL, EL:10 WIRE ORANGE	80009	352-0168-03
	352-0168-05		1						CONN BODY, PL, EL:10 WIRE GREEN	80009	352-0168-05
	352-0168-07		1						CONN BODY, PL, EL:10 WIRE VIOLET	80009	352-0168-07
-202	175-1960-00		1						CABLE ASSY, RF:50 OHM COAX, 19.5 L	80009	175-1960-00
-203	175-1954-00		1						CABLE ASSY, RF:50 OHM COAX, 17.0 L	80009	175-1954-00
-204	175-1958-00		1						CABLE ASSY, RF:50 OHM COAX, 9.0 L	80009	175-1958-00
-205	175-1955-00		1						CABLE ASSY, RF:50 OHM COAX, 28.0 L	80009	175-1955-00
-206	175-1963-00		1						CABLE ASSY, RF:50 OHM COAX, 21.0 L	80009	175-1963-00

הנהגות המנהל (הנהגות המנהל) (הנהגות המנהל) (הנהגות המנהל) (הנהגות המנהל)

Replaceable Mechanical Parts—7L18 Service

Fig. & Index No.	Tektronix Part No.	Serial/Model No. Eff Dscont	Qty	1 2 3 4 5	Name & Description	Mfr Code	Mfr Part Number
2-1	-----		1		CKT BOARD ASSY:MICRO COMPUTER(SEE A300 REPL) (ATTACHING PARTS)		
-2	211-0087-01		2		SCREW,MACHINE:2-56 X 0.188,FLH 82 DEG,STL	83385	OBD
-3	210-0405-00		1		NUT,PLAIN,HEX.:2-56 X 0.188 INCH,BRS	73743	12157-50
-4	210-1122-00		1		WASHER,LOCK:0.12 ID,DISHED,0.025 THK	86928	OBD
-5	211-0034-00		1		SCREW,MACHINE:2-56 X 0.50 INCH,PNH	83385	OBD
					- - - * - - -		
					- CKT BOARD ASSY INCLUDES:		
-6	131-2002-00		1		. CONN,RCPT,ELEC:CKT BOARD,5 CONT,FEMALE	22526	65001-110
-7	131-1881-00		1		. CONN,RCPT,ELEC:CKT BD,13 FEM,SINGLE ROW	22526	65001-011
-8	136-0252-04	B010100 B020499	315		. SOCKET,PIN TERM:U/W 0.016-0.018 DIA PINS	22526	75060-007
	136-0252-07	B020500	71		. SOCKET,PIN CONN:W/O DIMPLE	22526	75060-012
-9	342-0202-00		2		INSULATOR,PLATE:TRANSISTOR	01295	10-21-023-106
-10	214-2467-00		1		PIN HINGE:0.081 DIA X 0.5 LONG,SST	80009	214-2467-00
-11	352-0458-02		1		HOLDER,CKT BD:MICRO COMPUTER	80009	352-0458-02
-12	-----				- CKT BOARD ASSY:STOR INTFC(SEE A4508 REPL)		
-13	136-0252-04	B010100 B020499	171		. SOCKET,PIN TERM:U/W 0.016-0.018 DIA PINS	22526	75060-007
	136-0252-07	B020500	165		. SOCKET,PIN CONN:W/O DIMPLE	22526	75060-012
-14	136-0263-04		26		. SOCKET,PIN TERM:FOR 0.025 INCH SQUARE PIN	22526	75377-001
-15	-----				- CKT BOARD ASSY:DIGITAL STORAGE(SEE A400 REPL) (ATTACHING PARTS)		
-16	211-0022-00		5		SCREW,MACHINE:2-56 X 0.188 INCH,PNH STL	83385	OBD
					- - - * - - -		
					- CKT BOARD ASSY INCLUDES:		
-17	131-1771-00		1		. CONNECTOR,RCPT,:CIRCUIT CARD,6 FEMALE	22526	65001-111
-18	131-2002-00		3		. CONN,RCPT,ELEC:CKT BOARD,5 CONT,FEMALE	22526	65001-110
-19	131-1633-00		1		. CONNECTOR,RCPT,:CKT CARD MTG	22526	65001-009
-20	136-0252-04	B010100 B020499	373		. SOCKET,PIN TERM:U/W 0.016-0.018 DIA PINS	22526	75060-007
	136-0252-07	B020500	287		. SOCKET,PIN CONN:W/O DIMPLE	22526	75060-012
-21	131-0787-00		26		. CONTACT,ELEC:0.64 INCH LONG	22526	47359
-22	136-0260-02		2		. SKT,PL-IN ELEK:MICROCIRCUIT,16 DIP,LOW CLE	71785	133-51-92-008
-23	210-1181-00		1		WASHER,SHLDR:1.22 ID X 0.20D	31223	OBD
-24	342-0202-00		2		INSULATOR,PLATE:TRANSISTOR	01295	10-21-023-106
-25	352-0458-05		1		HOLDER,CKT BD:DIGITAL STORAGE	80009	352-0458-05
-26	-----				- CKT BOARD ASSY:CTR FREQ DVM(SEE A450 REPL) (ATTACHING PARTS)		
-27	211-0087-01		4		SCREW,MACHINE:2-56 X 0.188,FLH 82 DEG,STL	83385	OBD
					- - - * - - -		
					- CKT BOARD ASSY INCLUDES:		
-28	136-0260-02		3		. SKT,PL-IN ELEK:MICROCIRCUIT,16 DIP,LOW CLE	71785	133-51-92-008
-29	131-2002-00		3		. CONN,RCPT,ELEC:CKT BOARD,5 CONT,FEMALE	22526	65001-110
-30	136-0269-02		4		. SKT,PL-IN ELEK:MICROCIRCUIT,14 DIP,LOW CLE	73803	CS9002-14
-31	131-1881-00		1		. CONN,RCPT,ELEC:CKT BD,13 FEM,SINGLE ROW	22526	65001-011
-32	136-0252-04	B010100 B020499	28		. SOCKET,PIN TERM:U/W 0.016-0.018 DIA PINS	22526	75060-007
	136-0252-07	B020500	10		. SOCKET,PIN CONN:W/O DIMPLE	22526	75060-012
-33	131-1493-00		1		. CONTACT,ELEC:TEST POINT STRAP	80009	131-1493-00
-34	214-0579-00		7		. TERM,TEST POINT:BRS CD PL	80009	214-0579-00
-35	136-0578-00		1		. SKT,PL-IN ELEK:MICROCKT,24 PIN,LOW PROFILE	73803	C S9002-24
-36	136-0514-00		4		. SKT,PL-IN ELEK:MICROCIRCUIT,8 DIP	73803	CS9002-8
-37	352-0458-00		1		HOLDER,CKT BD:	80009	352-0458-00
-38	200-2117-00		4		COVER,CKT BD:	80009	200-2117-00
					(ATTACHING PARTS)		
-39	211-0225-00		8		SCR,CAP,SOC HD:4-40 X 0.312 INCH,STL	000AH	OBD
					- - - * - - -		
-40	175-1964-00		1		CABLE ASSY,RF:50 OHM COAX,13.0 L	80009	175-1964-00
-41	-----				- CKT BOARD ASSY:LOG & VERT AMPL(SEE A550 REPL) (ATTACHING PARTS)		
-42	211-0087-01		4		. SCREW,MACHINE:2-56 X 0.188,FLH 82 DEG,STL	83385	OBD
					- - - * - - -		
					- CKT BOARD ASSY INCLUDES:		
-43	342-0147-00		12		. INSULATOR,BSHG:	80009	342-0147-00
-44	136-0260-02	B010100 B020499	2		. SKT,PL-IN ELEK:MICROCIRCUIT,16 DIP,LOW CLE	71785	133-51-92-008
	136-0260-02	B020500	1		. SKT,PL-IN ELEK:MICROCIRCUIT,16 DIP,LOW CLE	71785	133-51-92-008
-45	131-1881-00		3		. CONN,RCPT,ELEC:CKT BD,5 CONTACT FEMALE	22526	65001-011
-46	136-0252-04	B010100 B020499	89		. SOCKET,PIN TERM:U/W 0.016-0.018 DIA PINS	22526	75060-007
	136-0252-07	B020500	50		. SOCKET,PIN CONN:W/O DIMPLE	22526	75060-012

Replaceable Mechanical Parts—7L18 Service

Fig. & Index No.	Tektronix Part No.	Serial/Model No. Eff Dscont	Qty	1	2	3	4	5	Name & Description	Mfr Code	Mfr Part Number
2-47	131-1493-00		1						. CONTACT,ELEC:TEST POINT STRAP	80009	131-1493-00
-48	131-1425-00		1						. CONTACT SET,ELE:R ANGLE,0.150" L,STR OF 36	22526	65521-136
-49	352-0458-04		1						HOLDER,CKT BD:LOG AMPL AND VERTICAL	80009	352-0458-04
-50	175-2037-00		1						CABLE ASSY,RF:50 OHM COAX,12.5 L	80009	175-2037-00
-51	175-1957-00		1						CABLE ASSY,RF:50 OHM COAX,14.0 L	80009	175-1957-00
-52	175-2036-00		1						CABLE ASSY,RF:50 OHM COAX,10.0 L	80009	175-2036-00
-53	175-1956-00		1						CABLE ASSY,RF:50 OHM COAX,10.0 L	80009	175-1956-00
-54	-----		1						FILTER,BANDPASS:(SEE A3415 REPL) (ATTACHING PARTS)		
-55	210-0405-00		2						NUT,PLAIN,HEX.:2-56 X 0.188 INCH,BRS	73743	12157-50
-56	210-1002-00		2						WASHER,FLAT:0.125 ID X 0.25 INCH OD,BRS	12327	OBD
									-----*		
-57	-----		1						FILTER,BANDPASS:(SEE A3410 REPL) (ATTACHING PARTS)		
-58	211-0008-00		2						SCREW,MACHINE:4-40 X 0.25 INCH,PNH STL	83385	OBD
									-----*		
-59	214-1611-00		1						HEAT SINK,ELEC:0.280 ID,W/ 4-40 THREADS (ATTACHING PARTS)	05820	260-4T5E-C4631
-60	211-0007-00		1						SCREW,MACHINE:4-40 X 0.188 INCH,PNH STL	83385	OBD
									-----*		
-61	-----		1						CKT BOARD ASSY:VR NOISE FLTR(SEE A3420 REPL) (ATTACHING PARTS)		
-62	211-0087-01		2						SCREW,MACHINE:2-56 X 0.188,FLH 82 DEG,STL	83385	OBD
-63	210-0405-00		1						NUT,PLAIN,HEX.:2-56 X 0.188 INCH,BRS	73743	12157-50
-64	210-1122-00		1						WASHER,LOCK:0.12 ID,DISHED,0.025 THK	86928	OBD
-65	211-0034-00		1						SCREW,MACHINE:2-56 X 0.50 INCH,PNH	83385	OBD
									-----*		
									CKT BOARD ASSY INCLUDES:		
-66	131-1881-00		1						. CONN,RCPT,ELEC:CKT BD,13 FEM,SINGLE ROW	22526	65001-011
-67	136-0252-04	B010100 B020499	23						. SOCKET,PIN TERM:U/W 0.016-0.018 DIA PINS	22526	75060-007
	136-0252-07	B020500	3						. SOCKET,PIN CONN:W/O DIMPLE	22526	75060-012
-68	131-1425-00		1						. CONTACT SET,ELE:R ANGLE,0.150" L,STR OF 36	22526	65521-136
-69	342-0202-00	B010100 B020319	2						INSULATOR,PLATE:TRANSISTOR	01295	10-21-023-106
	342-0202-00	B020320	4						INSULATOR,PLATE:TRANSISTOR	01295	10-21-023-106
-70	352-0458-03		1						HOLDER,CKT BD:300KHZ FILTER	80009	352-0458-03
-71	-----		1						CKT BD ASSY:PHASE LOCK LGC CNTRL(SEE A1170 REPL) (ATTACHING PARTS)		
-72	211-0087-01		4						SCREW,MACHINE:2-56 X 0.188,FLH 82 DEG,STL	83385	OBD
									-----*		
									CKT BOARD ASSY INCLUDES:		
-73	131-1771-00		1						. CONNECTOR,RCPT :CIRCUIT CARD,6 FEMALE	22526	65001-111
-74	131-1881-00		1						. CONN,RCPT,ELEC:CKT BD,13 FEM,SINGLE ROW	22526	65001-011
-75	131-2002-00		1						. CONN,RCPT,ELEC:CKT BOARD,5 CONT,FEMALE	22526	65001-110
-76	136-0269-02		4						. SKT,PL-IN ELEC:MICROCIRCUIT,14 DIP,LOW CLE	73803	CS9002-14
-77	136-0260-02		4						. SKT,PL-IN ELEC:MICROCIRCUIT,16 DIP,LOW CLE	71785	133-51-92-008
-78	136-0252-04	B010100 B020499	49						. SOCKET,PIN TERM:U/W 0.016-0.018 DIA PINS	22526	75060-007
	136-0252-07	B020500	20						. SOCKET,PIN CONN:W/O DIMPLE	22526	75060-012
-79	131-1493-00		2						. CONTACT,ELEC:TEST POINT STRAP	80009	131-1493-00
-80	214-0579-00		6						. TERM,TEST POINT:BRS CD PL	80009	214-0579-00
-81	136-0514-00		3						. SKT,PL-IN ELEC:MICROCIRCUIT,8 DIP	73803	CS9002-8
-82	352-0458-00		1						HOLDER,CKT BD:	80009	352-0458-00
-83	200-2011-00		1						COVER,MODULE:PHASE LOCK (ATTACHING PARTS)	80009	200-2011-00
-84	211-0087-01		12						SCREW,MACHINE:2-56 X 0.188,FLH 82 DEG,STL	83385	OBD
-85	211-0022-00		4						SCREW,MACHINE:2-56 X 0.188 INCH,PNH STL	83385	OBD
									-----*		
-86	342-0391-00		1						INSULATOR,SHLD:CKT BD,REF OSC,POLYESTER	80009	342-0391-00
-87	337-2328-00		1						SHIELD,ELEC:CKT BD,REFERENCE OSC	80009	337-2328-00
-88	337-2329-00		1						SHIELD,ELEC:CKT BD,MIXER	80009	337-2329-00
-89	342-0391-00		1						INSULATOR,SHLD:CKT BD,REF OSC,POLYESTER	80009	342-0391-00
-90	337-2330-00		1						SHIELD,ELEC:CKT BD,PHASE FREQ DETECTOR	80009	337-2330-00
-91	342-0391-00		1						INSULATOR,SHLD:CKT BD,REF OSC,POLYESTER	80009	342-0391-00
-92	337-2331-00		1						SHIELD,ELEC:CKT BD,CONTROLLED OSC	80009	337-2331-00
-93	131-1612-01		5						TERMINAL,FEEDTH:W/INSULATOR	80009	131-1612-01
-94	-----		1						CKT BOARD ASSY:REFERENCE OSC(SEE A940A1 REPL) (ATTACHING PARTS)		
-95	211-0007-00		6						SCREW,MACHINE:4-40 X 0.188 INCH,PNH STL	83385	OBD
									-----*		

Replaceable Mechanical Parts—7L 18 Service

Fig. & Index No.	Tektronix Part No.	Serial/Model No. Eff Dscont	Qty	1 2 3 4 5	Name & Description	Mfr Code	Mfr Part Number
2-	-----		-		CKT BOARD ASSY INCLUDES:		
-96	136-0263-04		1		. SOCKET, PIN TERM: FOR 0.025 INCH SQUARE PIN	22526	75377-001
-97	136-0252-04	B010100 B020499	46		. SOCKET, PIN TERM: U/W 0.016-0.018 DIA PINS	22526	75060-007
	136-0252-07	B020500	12		. SOCKET, PIN CONN: W/O DIMPLE	22526	75060-012
-98	131-0608-00		6		. TERMINAL, PIN: 0.365 L X 0.025 PH BRZ GOLD	22526	47357
-99	214-0579-00		2		. TERM, TEST POINT: BRS CD PL	80009	214-0579-00
	131-0566-00	XB020665	1		. BUS CONDUCTOR: DUMMY RES, 2.375, 22 AWG	55210	L-2007-1
-100	-----		1		CKT BOARD ASSY: MIXER (SEE A940A2 REPL) (ATTACHING PARTS)		
-101	211-0007-00		4		SCREW, MACHINE: 4-40 X 0.188 INCH, PNH STL	83385	OBD
	-----				- - - * - - -		
-102	136-0263-04		3		. SOCKET, PIN TERM: FOR 0.025 INCH SQUARE PIN	22526	75377-001
-103	214-0579-00		2		. TERM, TEST POINT: BRS CD PL	80009	214-0579-00
-104	-----		1		CKT BOARD ASSY: PH/FREQ DET (SEE A940A3 REPL) (ATTACHING PARTS)		
-105	211-0007-00		4		SCREW, MACHINE: 4-40 X 0.188 INCH, PNH STL	83385	OBD
	-----				- - - * - - -		
-106	136-0269-02		2		. SKT, PL-IN ELEK: MICROCIRCUIT, 14 DIP, LOW CLE	73803	CS9002-14
-107	131-0608-00		3		. TERMINAL, PIN: 0.365 L X 0.025 PH BRZ GOLD	22526	47357
-108	214-0579-00		2		. TERM, TEST POINT: BRS CD PL	80009	214-0579-00
-109	136-0252-04	B010100 B020499	18		. SOCKET, PIN TERM: U/W 0.016-0.018 DIA PINS	22526	75060-007
	136-0252-07	B020500	8		. SOCKET, PIN CONN: W/O DIMPLE	22526	75060-012
-110	136-0263-04		3		. SOCKET, PIN TERM: FOR 0.025 INCH SQUARE PIN	22526	75377-001
-111	-----		1		CKT BOARD ASSY: CONTROLLED OSC (SEE A940A4 REPL) (ATTACHING PARTS)		
-112	211-0007-00		6		SCREW, MACHINE: 4-40 X 0.188 INCH, PNH STL	83385	OBD
	-----				- - - * - - -		
-113	131-0608-00		1		. TERMINAL, PIN: 0.365 L X 0.025 PH BRZ GOLD	22526	47357
-114	136-0252-04	B010100 B020499X	18		. SOCKET, PIN TERM: U/W 0.016-0.018 DIA PINS	22526	75060-007
-115	214-0579-00		1		. TERM, TEST POINT: BRS CD PL	80009	214-0579-00
-116	136-0263-04		3		. SOCKET, PIN TERM: FOR 0.025 INCH SQUARE PIN	22526	75377-001
-117	-----		1		. XFMR, RF: (SEE T1062 REPL) (ATTACHING PARTS)		
-118	210-0406-00		1		. NUT, PLAIN, HEX: 4-40 X 0.188 INCH, BRS	73743	12161-50
-119	211-0036-00		1		. SCREW, MACHINE: 4-40 X 0.500, BDGH, NYL, SLOT	26365	921-4120-0014
-120	210-0935-00		2		. WASHER, NONMETAL: FIBER, 0.14 IDX 0.375"OD	74921	OBD
	-----				- - - * - - -		
-121	214-2596-00		23		PIN, SPRING: 0.157 ID X 0.189 OD, BRASS	80009	214-2596-00
-122	131-0593-00		2		CONTACT, ELEC: 1.15 INCH LONG	22526	47354
-123	131-1170-00	B010100 B010519	2		CONN, RCPT, ELEC: SNAP-ON, MALE	98291	51-045-0249
	131-1170-01	B010520	2		CONN, RCPT, ELEC: SNAP-ON MALE		
-124	200-1989-00		1		COVER, MODULE: PHASE LOCK (ATTACHING PARTS)	80009	200-1989-00
-125	211-0087-01		7		SCREW, MACHINE: 2-56 X 0.188, FLH 82 DEG, STL	83385	OBD
-126	211-0022-00		8		SCREW, MACHINE: 2-56 X 0.188 INCH, PNH STL	83385	OBD
	-----				- - - * - - -		
-127	348-0557-00		1		PAD, CUSHIONING: 0.63 X 0.125 SILICONE RUBBER		
-128	337-2462-00		1		SHIELD, ELEC: OFFSET OSCILLATOR, TOP	80009	337-2462-00
-129	342-0390-00		1		INSULATOR, SHLD: CKT BD, OFFSET OSC	80009	342-0390-00
-130	337-2332-00		1		SHIELD, ELEC: CKT BD, 16MHZ FILTER	80009	337-2332-00
-131	342-0392-00		1		INSULATOR, SHLD: CKT BD, STROBE DRIVER	80009	342-0392-00
-132	337-2327-00		1		SHIELD, ELEC: CKT BD, STROBE DRIVER	80009	337-2327-00
-133	131-1612-01		1		TERMINAL, FEEDTH: W/INSULATOR	80009	131-1612-01
-134	-----		1		CKT BOARD ASSY: 16MHZ FILTER (SEE A940A5 REPL) (ATTACHING PARTS)		
-135	211-0007-00		4		SCREW, MACHINE: 4-40 X 0.188 INCH, PNH STL	83385	OBD
	-----				- - - * - - -		
-136	136-0263-04		2		. SOCKET, PIN TERM: FOR 0.025 INCH SQUARE PIN	22526	75377-001
-137	337-2325-00		1		. SHIELD, ELEC: CKT BD, 16MHZ FLTR DIVIDER	80009	337-2325-00
-138	-----		1		CKT BOARD ASSY: STROBE DRIVER (SEE A940A6 REPL) (ATTACHING PARTS)		
-139	211-0007-00		4		SCREW, MACHINE: 4-40 X 0.188 INCH, PNH STL	83385	OBD
	-----				- - - * - - -		

Replaceable Mechanical Parts—7L18 Service

Fig. & Index No.	Tektronix Part No.	Serial/Model No. Eff Dscont	Qty	1	2	3	4	5	Name & Description	Mfr Code	Mfr Part Number	
2-	-----	-----	-	CKT BOARD ASSY INCLUDES:								
-140	136-0263-04		1	. SOCKET,PIN TERM:FOR 0.025 INCH SQUARE PIN					22526	75377-001		
-141	136-0252-04	B010100 B020499X	11	. SOCKET,PIN TERM:U/W 0.016-0.018 DIA PINS					22526	75060-007		
-142	214-0579-00		2	. TERM,TEST POINT:BRS CD PL					80009	214-0579-00		
-143	131-0608-00		5	. TERMINAL,PIN:0.365 L X 0.025 PH BRZ GOLD					22526	47357		
-144	136-0269-02		1	. SKT,PL-IN ELEK:MICROCIRCUIT,14 DIP,LOW CLE					73803	CS9002-14		
-145	346-0150-00		1	STRAP,OF S OSC:1.368 INCH LONG,SST (ATTACHING PARTS)					80009	346-0150-00		
-146	211-0034-00		2	SCREW,MACHINE:2-56 X 0.50 INCH,PNH -----*					83385	OBD		
-147	-----	-----	1	CKT BOARD ASSY:OFFSET OSC(SEE A940A7A1 REPL) (ATTACHING PARTS)								
-148	211-0159-00		3	SCREW,MACHINE:2-56 X 0.375 INCH,PNH STL -----*					87308	OBD		
-149	214-0579-00		6	. TERM,TEST POINT:BRS CD PL					80009	214-0579-00		
-150	136-0514-00		2	. SKT,PL-IN ELEK:MICROCIRCUIT,8 DIP					73803	CS9002-8		
-151	131-0787-00		8	. CONTACT,ELEC:0.64 INCH LONG					22526	47359		
-152	136-0252-07	B010100 B020499	22	. SOCKET,PIN CONN:W/O DIMPLE					22526	75060-012		
-153	136-0252-07	B020500	4	. SOCKET,PIN CONN:W/O DIMPLE					22526	75060-012		
-154	211-0036-00		1	. SCREW,MACHINE:4-40 X 0.500,BDGH,NYL,SLOT					26365	921-4120-0014		
-155	210-0849-00		2	. WSHR,SHOULDERED:0.11 ID X 0.188"OD,FIBER -----*					83330	2151		
-156	131-0608-00		9	. TERMINAL,PIN:0.365 L X 0.025 PH BRZ GOLD					22526	47357		
-157	136-0263-04		1	. SOCKET,PIN TERM:FOR 0.025 INCH SQUARE PIN					22526	75377-001		
-158	136-0269-02		3	. SKT,PL-IN ELEK:MICROCIRCUIT,14 DIP,LOW CLE					73803	CS9002-14		
-159	337-2461-00		1	SHILED ELEC:OFFSETR OSCILLATOR, TOP					80009	337-2461-00		
-160	337-2463-00		1	SHIELD,ELEC:OFFSET OSCILLATOR,BOTTOM					80009	337-2463-00		
-161	380-0475-00		1	HOUSING,MODULE:PHASE LOCK					80009	380-0475-00		
-162	-----	-----	1	CKT BOARD ASSY:SPAN ATTEN(SEE A1270 REPL) (ATTACHING PARTS)								
-163	211-0087-01		4	SCREW,MACHINE:2-56 X 0.188,FLH 82 DEG,STL -----*					83385	OBD		
-164	131-1881-00		1	. CONN,RCPT,ELEC:CKT BD,13 FEM,SINGLE ROW					22526	65001-011		
-165	131-2002-00		3	. CONN,RCPT,ELEC:CKT BOARD,5 CONT,FEMALE					22526	65001-110		
-166	136-0269-02		2	. SKT,PL-IN ELEK:MICROCIRCUIT,14 DIP,LOW CLE					73803	CS9002-14		
-167	136-0514-00		4	. SKT,PL-IN ELEK:MICROCIRCUIT,8 DIP					73803	CS9002-8		
-168	136-0252-04	B010100 B020499X	85	. SOCKET,PIN TERM:U/W 0.016-0.018 DIA PINS					22526	75060-007		
-169	214-0579-00		5	. TERM,TEST POINT:BRS CD PL					80009	214-0579-00		
-170	136-0260-02		5	. SKT,PL-IN ELEK:MICROCIRCUIT,16 DIP,LOW CLE					71785	133-51-92-008		
-171	352-0458-01		1	HOLDER,CKT BD:SPAN					80009	352-0458-01		
-172	-----	-----	1	CKT BOARD ASSY:HORIZONTAL(SEE A1390 REPL) (ATTACHING PARTS)								
-173	211-0087-01		3	SCREW,MACHINE:2-56 X 0.188,FLH 82 DEG,STL					83385	OBD		
-174	211-0022-00		1	SCREW,MACHINE:2-56 X 0.188 INCH,PNH STL					83385	OBD		
-175	210-1289-00		1	WASHER,SHLDR:0.093 ID,0.085 L,FIBER/MICA -----*					86928	OBD		
-176	131-1881-00		2	. CONN,RCPT,ELEC:CKT BD,13 FEM,SINGLE ROW					22526	65001-011		
-177	131-2002-00		2	. CONN,RCPT,ELEC:CKT BOARD,5 CONT,FEMALE					22526	65001-110		
-178	136-0269-02		2	. SKT,PL-IN ELEK:MICROCIRCUIT,14 DIP,LOW CLE					73803	CS9002-14		
-179	136-0514-00		3	. SKT,PL-IN ELEK:MICROCIRCUIT,8 DIP					73803	CS9002-8		
-180	136-0252-04	B010100 B020499	73	. SOCKET,PIN TERM:U/W 0.016-0.018 DIA PINS					22526	75060-007		
-181	136-0252-07	B020500	10	. SOCKET,PIN CONN:W/O DIMPLE					22526	75060-012		
-182	136-0260-02		6	. SKT,PL-IN ELEK:MICROCIRCUIT,16 DIP,LOW CLE					71785	133-51-92-008		
-183	352-0458-00		1	HOLDER,CKT BD:					80009	352-0458-00		
-184	211-0087-01		4	CKT BOARD ASSY:CENTER FREQ RDOUT(SEE A1650 REPL) (ATTACHING PARTS)								
-185	131-1881-00		2	. CONN,RCPT,ELEC:CKT BD,13 FEM,SINGLE ROW					22526	65001-011		
-186	131-2002-00		2	. CONN,RCPT,ELEC:CKT BOARD,5 CONT,FEMALE					22526	65001-110		
-187	136-0260-02		7	. SKT,PL-IN ELEK:MICROCIRCUIT,16 DIP,LOW CLE					71785	133-51-92-008		

Replaceable Mechanical Parts—7L18 Service

Fig. & Index No.	Tektronix Part No.	Serial/Model No. Eff	Dscont	Qty	1	2	3	4	5	Name & Description	Mfr Code	Mfr Part Number
2-188	136-0252-07	B010100	B020499X	39	.					SOCKET, PIN CONN:W/O DIMPLE	22526	75060-012
-189	136-0269-02			14	.					SKT, PL-IN ELEK:MICROCIRCUIT, 14 DIP, LOW CLE	73803	CS9002-14
-190	352-0458-00			1						HOLDER, CKR BD:	80009	352-0458-00
-191	-----			1						CKT BOARD ASSY: CRT READOUT(SEE A1750 REPL) (ATTACHING PARTS)		
-192	211-0087-01			4						SCREW, MACHINE: 2-56 X 0.188, FLH 82 DEG, STL	83385	OBD
	-----									----- * -----		
-193	131-1881-00			2	.					CONN, RCPT, ELEC: CKT BD, 13 FEM, SINGLE ROW	22526	65001-011
-194	131-2002-00			2	.					CONN, RCPT, ELEC: CKT BOARD, 5 CONT, FEMALE	22526	65001-110
-195	136-0260-02			4	.					SKT, PL-IN ELEK: MICROCIRCUIT, 16 DIP, LOW CLE	71785	133-51-92-008
-196	136-0252-04	B010100	B020499X	39	.					SOCKET, PIN TERM: U/W 0.016-0.018 DIA PINS	22526	75060-007
-197	136-0269-02			12	.					SKT, PL-IN ELEK: MICROCIRCUIT, 14 DIP, LOW CLE	73803	CS9002-14
-198	352-0458-00			1						HOLDER, CKT BD:	80009	352-0458-00
-199	426-1321-00			1						FRAME SECT, CAB: UPPER RIGHT (ATTACHING PARTS)	80009	426-1321-00
-200	211-0183-00			1						SCREW, MACHINE: 4-40 X 0.50 INCH, SOC HEX HD	000AH	OBD
-201	211-0254-00			2						WASHER, FLAT: 0.119 ID X 0.025 THK, STL CD	000BK	OBD
	-----									----- * -----		
-202	-----			1						CKT BOARD ASSY: HORIZ INTFC(SEE A2870 REPL) (ATTACHING PARTS)		
-203	214-0660-00			2						PIN, STR, HDLS: 0.062 OD X 0.312" LONG, STL	22599	59-012-062-0312
	-----									----- * -----		
-204	131-0566-00	B010100	B020624X	1	.					BUS CONDUCTOR: DUMMY RES, 2.375, 22 AWG	55210	L-2007-1
-205	131-0608-00			21	.					TERMINAL, PIN: 0.365 L X 0.025 PH BRZ GOLD	22526	47357
-206	-----			1						CKT BOAD ASSY: CTR INTERFACE(SEE A2860 REPL) (ATTACHING PARTS)		
-207	214-0660-00			2						PIN, STR, HDLS: 0.062 OD X 0.312" LONG, STL	22599	59-012-062-0312
	-----									----- * -----		
-208	131-0827-00			2	.					CONTACT, ELEC: 0.55 INCH LONG	22526	48283-028
-209	131-0608-00			18	.					TERMINAL, PIN: 0.365 L X 0.025 PH BRZ GOLD	22526	47357
-210	-----			1						CKT BOARD ASSY: VERT INTERFACE(SEE A2850 REPL) (ATTACHING PARTS)		
-211	214-0660-00			2						PIN, STR, HDLS: 0.062 OD X 0.312" LONG, STL	22599	59-012-062-0312
	-----									----- * -----		
-212	131-0608-00			23	.					TERMINAL, PIN: 0.365 L X 0.025 PH BRZ GOLD	22526	47357
-213	384-1474-00			1						ROD, SUPPORT: 0.125 OD X 3.594 INCH LONG	80009	384-1474-00
-214	426-1322-00			1						FRAME SECT, CAB: UPPER LEFT (ATTACHING PARTS)	80009	426-1322-00
-215	211-0083-00			1						SCREW, MACHINE: 4-40 X 0.250, PNH, STL	83385	OBD
-216	211-0097-00			2						SCREW, MACHINE: 4-40 X 0.312 INCH, PNH STL	83385	OBD
-217	211-0254-00			1						WASHER, FLAT: 0.119 ID X 0.025 THK, STL CD	000BK	OBD
	-----									----- * -----		
-218	346-0032-00			3						STRAP, RETAINING: 0.075 DIA X 4.0 L, MLD RBR	98159	2859-75-4
-219	351-0217-03			2						GUIDE, CKT BD: 4.7 INCH LONG, SIL GRAY DLERIN (ATTACHING PARTS FOR EACH)	80009	351-0217-03
-220	211-0512-00			4						SCREW, MACHINE: 6-32 X 0.50" 100 DEG, FLH STL	83385	OBD
-221	220-0557-00			4						NUT, SLEEVE: 6-32 X 0.204 OD X 0.118 L BRS	80009	220-0557-00
	-----									----- * -----		
-222	351-0217-04			1						GUIDE, CKT BD: 4.7 INCH LONGSIL GRAY DELRIN (ATTACHING PARTS)	80009	351-0217-04
-223	211-0512-00			4						SCREW, MACHINE: 6-32 X 0.50" 100 DEG, FLH STL	83385	OBD
-224	220-0556-00			4						NUT, SLEEVE: 6-32 X 0.252 OD X 0.015"L BRS	80009	220-0556-00
	-----									----- * -----		
-225	214-2600-00			1						SPRING, SPRT ROD: (ATTACHING PARTS)	80009	214-2600-00
-226	211-0005-00			1						SCREW, MACHINE: 4-40 X 0.125 INCH, PNH STL	83385	OBD
	-----									----- * -----		
-227	386-2782-01	B010100	B020449	1						SPRT, REAR PANEL: UPPER	80009	386-2782-01
	386-2782-02		B020450	1						SPRT, REAR PANEL: UPPER	80009	386-2782-02
-228	386-2781-01	B010100	B020449	1						SPRT, REAR PANEL: LOWER	80009	386-2781-01
	386-2781-02		B020450	1						SPRT, REAR PANEL: LOWER	80009	386-2781-02

Replaceable Mechanical Parts—7L18 Service

Fig. & Index No.	Tektronix Part No.	Serial/Model No. Eff Dscont	Qty	1 2 3 4 5	Name & Description	Mfr Code	Mfr Part Number
2-229	333-2180-00		1		PANEL, REAR: (ATTACHING PARTS)	80009	333-2180-00
-230	213-0192-00		3		SCR, TPG, THD FOR: 6-32 X 0.50 INCH, PNH STL - - - * - - -	87308	0BD
	198-3137-00		1		WIRE KIT, ELEC: HORIZONTAL ASSEMBLY	80009	198-3137-00
-231	175-0826-00		FT		. WIRE, ELECTRICAL: 3 WIRE RIBBON	80009	175-0826-00
-232	175-0827-00		FT		. CABLE, SP, ELEC: 4, 26 AWG, STRD, PVC JKT, RBN	08261	SS04267(1061)0C
-233	175-0829-00		FT		. WIRE, ELECTRICAL: 6 WIRE RIBBON	08261	SS-0626-710610C
-234	175-0830-00		FT		. WIRE, ELECTRICAL: 7 WIRE RIBBON	08261	SS-0726-710610C
-235	131-0707-00		40		. CONNECTOR, TERM: 22-26 AWG, BRS& CU BE GOLD	22526	47439
-236	131-2084-00		8		. TERM, QUICK DISC: 26 AWG, COPPERNICKEL	00779	5250-207-2
-237	352-0171-00		2		. HLDR, TERM CONN: 1 WIRE BLACK	80009	352-0171-00
-238	352-0169-00		1		. HLDR, TERM CONN: 2 WIRE BLACK	80009	352-0169-00
-239	352-0161-07		2		. CONN BODY, PL, EL: 3 WIRE VIOLET	80009	352-0161-07
-240	352-0162-00		1		. HLDR, TERM CONN: 4 WIRE BLACK	80009	352-0162-00
	352-0162-02		2		. CONN BODY, PL, EL: 4 WIRE RED	80009	352-0162-02
-241	352-0164-03		2		. CONN BODY, PL, EL: 6 WIRE ORANGE	80009	352-0164-03
-242	352-0165-04		2		. CONN BODY, PL, EL: 7 WIRE YELLOW	80009	352-0165-04
	198-3138-00		1		WIRE KIT, ELEC: PHSE LOCK ASSEMBLY	80009	198-3138-00
	131-0707-00		4		. CONNECTOR, TERM: 22-26 AWG, BRS& CU BE GOLD	22526	47439
	131-2084-00		18		. TERM, QUICK DISC: 26 AWG, COPPERNICKEL	00779	5250-207-2
	175-0827-00		FT		. CABLE, SP, ELEC: 4, 26 AWG, STRD, PVC JKT, RBN	08261	SS04267(1061)0C
	352-0171-00		2		. HLDR, TERM CONN: 1 WIRE BLACK	80009	352-0171-00
	352-0161-00		1		. HLDR, TERM CONN: 3 WIRE, BLACK	80009	352-0161-00
	352-0162-00		1		. HLDR, TERM CONN: 4 WIRE BLACK	80009	352-0162-00
	352-0164-00		1		. CONN BODY, PL, EL: 6 WIRE BLACK	80009	352-0164-00
-243	352-0167-00		1		. HLDR, TERM CONN: 9 WIRE BLACK	80009	352-0167-00

Replaceable Mechanical Parts—7L18 Service

Fig. & Index No.	Tektronix Part No.	Serial/Model No. Eff Dscont	Qty	1 2 3 4 5	Name & Description	Mfr Code	Mfr Part Number
3-	644-0086-00		1		RF ASSY:VERTICAL (ATTACHING PARTS)	80009	644-0086-00
-1	211-0102-00		1		SCREW,MACHINE:4-40 X 0.500",FLH,STL	83385	OBD
-2	211-0025-00		3		SCREW,MACHINE:4-40 X 0.375 100 DEG,FLH STL	83385	OBD
-3	401-0237-00		2		BEARING,SLEEVE:0.125 ID X 0.23 LONG,SST	80009	401-0237-00
-4	210-0589-00		2		NUT,SELF LKG HE:4-40 X 0.250 INCH	13257	22 NM-40
-5	210-1098-00		2		WASHER,FLAT:0.219 ID X 0.406 OD,NYLON - - - * - - -		
-6	337-1064-10		1		VERTICAL ASSY INCLUDES: . SHILED,ELEC:BOTTOM	80009	337-1064-10
-7	426-0681-00		4		. FR,PUSH BUTTON:GRAY PLASTIC	80009	426-0681-00
-8	366-1389-00		1		. KNOB:GRAY	80009	366-1389-00
	213-0306-00		1		. SETSCREW:2-56 X 0.062 INCH,OX STL	74445	OBD
-9	366-1540-00		1		. KNOB:GRAY	80009	366-1540-00
	213-0140-00		2		. SETSCREW:2-56 X 0.94 INCH,HEX SOC STL	70276	OBD
-10	015-1025-01		1		. TERM.,COAX:3MM MALE,50 OHM,W/CH	18203	T186C5
-11	366-1054-00		1		. KNOB:GRAY	80009	366-1054-00
	213-0153-00		2		. SETSCREW:5-40 X 0.125,STL BK OXD,HEX SKT	000CY	OBD
-12	354-0418-01		1		. RING,KNOB SKIRT:CLEAR,VERT DISP	80009	354-0418-01
-13	366-1336-00		1		. KNOB:GY,0-30,0.25 ID X 1.452 OD	80009	366-1336-00
-14	354-0412-00		1		. RING,KNOB SKIRT:BLACK,1.453 OD (ATTACHING PARTS)	80009	354-0412-00
-15	210-0405-00		2		. NUT,PLAIN,HEX.:2-56 X 0.188 INCH,BRS - - - * - - -	73743	12157-50
-16	-----		1		. CKT BOARD ASSY:VERT MICROCOMP INTERFACE - . (SEE A2550 REPL) (ATTACHING PARTS)		
-17	211-0022-00		1		. SCREW,MACHINE:2-56 X 0.188 INCH,PNH STL - - - * - - -	83385	OBD
-18	136-0260-02		5		CKT BOARD ASSY INCLUDES: . SKT,PL-IN ELEK:MICROCIRCUIT,16 DIP,LOW CLE	71785	133-51-92-008
-19	136-0252-04	B010100 B020499	15		. SOCKET,PIN TERM:U/W 0.016-0.018 DIA PINS	22526	75060-007
	136-0252-07	B020500	11		. SOCKET,PIN CONN:W/O DIMPLE	22526	75060-012
	131-1493-00	XB020500	2		. CONTACT,ELEC:TEST POINT STRAP	80009	131-1493-00
-20	136-0514-00		1		. SKT,PL-IN ELEK:MICROCIRCUIT,8 DIP	73803	CS9002-8
-21	346-0032-00		3		. STRAP,RETAINING:0.075 DIA X 4.0 L,MLD RBR	98159	2859-75-4
-22	131-2002-00		1		. CONN,RCPT,ELEC:CKT BOARD,5 CONT,FEMALE	22526	65001-110
-23	131-1425-00		1		. CONTACT SET,ELE:R ANGLE,0.150" L,STR OF 36	22526	65521-136
-24	-----		1		. FILTER,BANDPASS:(SEE F30 REPL) (ATTACHING PARTS)		
-25	211-0069-00		2		. SCREW,MACHINE:2-56 X 0.125 INCH,PNH STL	77250	OBD
-26	346-0151-00		1		. STRAP,RETAINING:FILTER,3 CAVITY,SST - - - * - - -	80009	346-0151-00
-27	407-1885-00		1		. T,FILTER:3 CAVITY (ATTACHING PARTS)	80009	407-1885-00
-28	211-0087-01		2		. SCREW,MACHINE:2-56 X 0.188,FLH 82 DEG,STL	83385	OBD
-29	210-0405-00		2		. NUT,PLAIN,HEX.:2-56 X 0.188 INCH,BRS	73743	12157-50
-30	210-1008-00		2		. WASHER,FLAT:0.09 ID X 0.188" OD,BRS - - - * - - -	12360	OBD
-31	-----		1		. CKT BOARD ASSY:YIG DRIVER(SEE A1962 REPL) (ATTACHING PARTS)		
-32	211-0116-00		2		. SCR,ASSEM WSHR:4-40 X 0.312 INCH,PNH BRS - - - * - - -	83385	OBD
-33	136-0260-02		4		CKT BOARD ASSY INCLUDES: . SKT,PL-IN ELEK:MICROCIRCUIT,16 DIP,LOW CLE	71785	133-51-92-008
-34	136-0252-04	B010100 B020499	71		. SOCKET,PIN TERM:U/W 0.016-0.018 DIA PINS	22526	75060-007
	136-0252-07	B020500	7		. SOCKET,PIN CONN:W/O DIMPLE	22526	75060-012
-35	136-0263-04		34		. SOCKET,PIN TERM:FOR 0.025 INCH SQUARE PIN	22526	75377-001
-36	214-0579-00		2		. TERM,TEST POINT:BRN CD PL	80009	214-0579-00
-37	136-0269-02		2		. SKT,PL-IN ELEK:MICROCIRCUIT,14 DIP,LOW CLE	73803	CS9002-14
-38	136-0261-00		4		. SOCKET,PIN TERM:FOR 0.22 INCH PIN	00779	1-331677-6
-39	136-0514-00		7		. SKT,PL-IN ELEK:MICROCIRCUIT,8 DIP	73803	CS9002-8
	131-1493-00	XB020500	2		. CONTACT,ELEC:TEST POINT STRAP	80009	131-1493-00
-40	342-0378-00		1		. INSL,CKT BOARD:YIG DRIVER,MYLAR	80009	342-0378-00
-41	-----		1		. CKT BOARD ASSY:YIG DRVR MOTHER(SEE A2890 REPL) (ATTACHING PARTS)		
-42	211-0112-00		6		. SCREW,MACHINE:2-56 X 0.375,FLH,100 DEG - - - * - - -	83385	OBD

Replaceable Mechanical Parts—7L18 Service

Fig. & Index No.	Tektronix Part No.	Serial/Model No. Eff Dscont	Qty	1	2	3	4	5	Name & Description	Mfr Code	Mfr Part Number
3-	-----		-	CKT BOARD ASSY INCLUDES:		
-43	129-0106-00		2	POST,ELEC-MECH:0.218 OD X 0.125 INCH L,RRS	80009	129-0106-00
-44	386-1556-00		4	SUPPORT,CKT BD:0.215 H,ACETAL	80009	386-1556-00
-45	129-0620-00		6	SPACER,POST:0.219 INCH LONG,HEX BRS	80009	129-0620-00
-46	131-0787-00		33	CONTACT,ELEC:0.64 INCH LONG	22526	47359
-47	131-0608-00		132	TERMINAL,PIN:0.365 L X 0.025 PH BRZ GOLD	22526	47357
-48	200-1988-00		1	OVER,CKT BOARD:500MHZ LO (ATTACHING PARTS)	80009	200-1988-00
-49	211-0087-01		12	SCREW,MACHINE:2-56 X 0.188,FLH 82 DEG,STL -----*-----	83385	OBD
-50	131-0593-00		1	CONTACT,ELEC:1.15 INCH LONG	22526	47354
-51	-----		1	CKT BOARD ASSY:500MHZ LO(SEE A2360A1 REPL) (ATTACHING PARTS)		
-52	211-0196-00		6	SCREW,MACHINE:4-40 X 0.188,SCH,HEX,STL -----*-----	000AH	OBD
-53	136-0234-00		-	CKT BOARD ASSY INCLUDES:		
-54	136-0252-04	B010100 B020499	2	SOCKET,PIN TERM:0.088 OD X 0.247 INCH L	00779	380598-1
	136-0252-07	B020500	32	SOCKET,PIN TERM:U/W 0.016-0.018 DIA PINS	22526	75060-007
-55	136-0514-00		19	SOCKET,PIN CONN:W/O DIMPLE	22526	75060-012
-56	136-0263-04		1	SKT,PL-IN ELEC:MICROCIRCUIT,8 DIP	73803	CS9002-8
-57	131-0157-00		1	SOCKET,PIN TERM:FOR 0.025 INCH SQUARE PIN	22526	75377-001
-58	-----		1	TERMINAL,PIN:0.25 L X 0.04OD,BRS	98291	013-1001-000-479
-59	211-0196-00		1	CKT BOARD ASSY:2ND MIXER(SEE A2360A2 REPL) (ATTACHING PARTS)		
	-----		3	SCREW,MACHINE:4-40 X 0.188,SCH,HEX,STL -----*-----	000AH	OBD
-60	136-0263-04		-	CKT BOARD ASSY INCLUDES:		
-61	131-0372-00		1	SOCKET,PIN TERM:FOR 0.025 INCH SQUARE PIN	22526	75377-001
-62	131-0157-00		1	CONNECTOR,RCPT,:COAXIAL	98291	51-043-4300
-63	175-1959-00		1	TERMINAL,PIN:0.25 L X 0.04OD,BRS	98291	013-1001-000-479
-64	380-0487-00		1	ABLE ASSY,RF:50 OHM COAX,3.5 INCH LONG	80009	175-1959-00
-65	211-0237-00		1	HSG,LOCAL OSC: (ATTACHING PARTS)	80009	380-0487-00
-66	211-0105-00		2	SCREW,CAP:2-56 X 0.25,HEX SOC,STL,CD PL	000CY	OBD
	-----		2	SCREW,MACHINE:4-40 X 0.188,100 DEG,FLH STL -----*-----	83385	OBD
-67	175-1900-00	B010100 B020162	1	CABLE ASSY,RF:50 OHM COAX,15.888 INCH LONG	80009	175-1900-00
	175-1900-01	B020163	1	CABLE ASSY,RF:50 OHM COAX,12.387 INCH LONG	80009	175-1900-01
-68	307-0553-00	XB020163	1	ATTENUATOR,FXD:10 DB	18203	OBD
-69	175-2207-00	XB020163	1	CABLE ASSY,RF:50 OHM,3.962 INCH LONG (ATTACHING PARTS)	80009	175-2207-00
-70	210-0590-00		1	NUT,PLAIN,HEX.:0.375 X 0.438 INCH,STL -----*-----	73743	2X28269-402
-71	131-1124-00		-	CABLE ASSY INCLUDES:		
-72	175-1898-00		1	CONN,RCPT,ELEC:BNC,FEMALE	24931	28JS155-1
-73	175-1895-00		1	CABLE ASSY,RF:50 OHM COAX,13.25 L	80009	175-1898-00
-74	175-1899-00		1	CABLE ASSY,RF:50 OHM,COAX,10.0 L	80009	175-1895-00
-75	-----		1	CABLE ASSY,RF:50 OHM COAX,2.0 L	80009	175-1899-00
-76	015-1011-00		1	DIODE ASSY:1ST CONVERTER(SEE A45 REPL)		
-77	-----		1	ADAPTER,CONN:SMA MALE TO SMA MALE	26805	2081-0000
-78	175-1896-00		1	FIRST CONV ASSY:(SEE A40 REPL)		
-79	175-1897-00		1	CABLE ASSY,RF:50 OHM COAX,5.0 INCH LONG	80009	175-1896-00
-80	200-1993-00		1	CABLE ASSY,RF:50 OHM COAX,3.62 INCH LONG	80009	175-1897-00
	-----		1	COVER,RF FILTER:510MHZ (ATTACHING PARTS)	80009	200-1993-00
-81	211-0237-00		21	SCREW,CAP:2-56 X 0.25,HEX SOC,STL,CD PL -----*-----	000CY	OBD
-82	342-0365-00		1	INSULATOR,PLATE:TRANSISTOR, SOCKET, PLASTIC	80009	342-0365-00
-83	342-0364-00		3	INSULATOR,PLATE:TRANSISTOR, SOCKET, PLASTIC	80009	342-0364-00
-84	131-0593-00		4	CONTACT,ELEC:1.15 INCH LONG	22526	47354
-85	-----		1	CKT BOARD ASSY:WG BND RESN8SEE A2690A2 REPL) (ATTACHING PARTS)		
-86	211-0162-00		6	SCREW,MACHINE:2-56 X 0.188 INCH,SCH,SST -----*-----	000AH	OBD

Replaceable Mechanical Parts—7L18 Service

Fig. & Index No.	Tektronix Part No.	Serial/Model No. Eff Dscont	Qty	1	2	3	4	5	Name & Description	Mfr Code	Mfr Part Number
3-	-----		-	CKT BOARD ASSY INCLUDES:		
-87	136-0252-04	B010100 B020499X	8	SOCKET,PIN TERM:U/W 0.016-0.018 DIA PINS	22526	75060-007
-88	131-0391-01		1	CONNECTOR,RCPT,:50 OHM,COAX,SNAP-ON MALE	98291	51-051-0119
-89	136-0263-04		2	SOCKET,PIN TERM:FOR 0.025 INCH SQUARE PIN	22526	75377-001
-90	-----		1	CKT BOARD ASSY:COAX BND RESN(SEE A2690A3 REPL) (ATTACHING PARTS)		
-91	211-0162-00		6	SCREW,MACHINE:2-56 X 0.188 INCH,SCH,SST	000AH	OBD
	-----		-	CKT BOARD ASSY INCLUDES:		
-92	136-0263-04		4	SOCKET,PIN TERM:FOR 0.025 INCH SQUARE PIN	22526	75377-001
-93	131-0391-01		1	CONNECTOR,RCPT,:50 OHM,COAX,SNAP-ON MALE	98291	51-051-0119
-94	136-0252-04	B010100 B020499X	11	SOCKET,PIN TERM:U/W 0.016-0.018 DIA PINS	22526	75060-007
-95	-----		1	CKT BOARD ASSY:510MHZ AMP(SEE A2690A1 REPL) (ATTACHING PARTS)		
-96	211-0162-00		7	SCREW,MACHINE:2-56 X 0.188 INCH,SCH,SST	000AH	OBD
	-----		-	CKT BOARD ASSY INCLUDES:		
-97	136-0263-04		4	SOCKET,PIN TERM:FOR 0.025 INCH SQUARE PIN	22526	75377-001
-98	136-0252-04	B010100 B020499X	21	SOCKET,PIN TERM:U/W 0.016-0.018 DIA PINS	22526	75060-007
-99	343-0708-00		2	CLAMP,CABLE: (ATTACHING PARTS FOR EACH)	80009	343-0708-00
-100	211-0087-01		1	SCREW,MACHINE:2-56 X 0.188,FLH 82 DEG,STL	83385	OBD
-101	175-1902-00		1	CABLE ASSY,RF:50 OHM COAX,1.752 INCH LONG	80009	175-1902-00
-102	-----		1	YIG TUNED FLTR:8SEE A20 REPL (ATTACHING PARTS)		
-103	211-0162-00		2	SCREW,MACHINE:2-56 X 0.188 INCH,SCH,SST	000AH	OBD
-104	346-0140-00		1	STRAP,RETAINING:PRESELECTOR,SST	80009	346-0140-00
-105	210-0850-00		2	WASHER,FLAT:0.093 ID X 0.281 INCH OD	12327	OBD
-106	220-0815-00		2	NUT,SLEEVE:2-56 X 0.125 OD X 0.25 LONG,SST	80009	220-0815-00
-107	380-0476-00		1	HOUSING,MODULE:510MHZ IF (ATTACHING PARTS)	80009	380-0476-00
-108	211-0038-00		3	SCREW,MACHINE:4-40 X 0.312,FLH,100 DEG	83385	OBD
-109	175-1961-00		1	CABLE ASSY,RF:50 OHM COAX,6.5 INCH LONG	80009	175-1961-00
-110	175-1901-00		1	CABLE ASSY,RF:50 OHM COAX,3.876 INCH LONG	80009	175-1901-00
-111	-----		1	PHASE GATE ASSY:(SEE A50 REPL) (ATTACHING PARTS)		
-112	211-0162-00		2	SCREW,MACHINE:2-56 X 0.188 INCH,SCH,SST	000AH	OBD
-113	346-0032-00		1	STRAP,RETAINING:0.075 DIA X 4.0 L,MLD RBR	98159	2859-75-4
-114	-----		1	ATTENUATOR ASSY:(SEE A10 REPL)		
-115	342-0395-00		1	INSULATOR,ATTEN:	80009	342-0395-00
-116	401-0359-00		1	PULLEY,FLAT:IDLER,ATTENUATOR	80009	401-0359-00
-117	401-0358-00		2	GEAR,SPUR:DRIVE,ATTENUATOR	80009	401-0358-00
-118	384-1439-00		1	SHAFT,GEAR:ATTENUATOR,IDLER	80009	384-1439-00
-119	214-2527-00		1	BELT,POS DRIVE:55 TOOTH,0.188 WIDE		
-120	131-0608-00		12	TERMINAL,PIN:0.365 L X 0.025 PH BRZ GOLD	22526	47357
-121	214-1126-01		2	SPRING,FLAT:0.7 X 0.125,CU BE GRN CLR	80009	214-1126-01
-122	214-1127-00		2	ROLLER,DETENT:0.125 DIA X 0.125,SST	80009	214-1127-00
-123	-----		1	CKT BOARD ASSY:RF FRONT PANEL(SEE A2640 REPL) (ATTACHING PARTS)		
-124	211-0022-00		4	SCREW,MACHINE:2-56 X 0.188 INCH,PNH STL	83385	OBD
	-----		-	CKT BOARD ASSY INCLUDES:		
-125	136-0252-07	B010100 B020499X	21	SOCKET,PIN CONN:W/O DIMPLE	22526	75060-012
-126	136-0260-02	B010100 B020499X	1	SKT,PL-IN ELEK:MICROCIRCUIT,16 DIP,LOW CLE	71785	133-51-92-008
-127	131-0787-00		5	CONTACT,ELEC:0.64 INCH LONG	22526	47359
-128	136-0608-00		13	SKT,PL-IN ELEK:ELECTRON TUBE,14 CONT	80009	136-0608-00
-129	-----		1	RESISTOR,VAR:(SEE R2628 REPL) (ATTACHING PARTS)		
-130	210-0583-00		2	NUT,PLAIN,HEX:0.25-32 X 0.312 INCH,BRS	73743	2X20317-402

Replaceable Mechanical Parts—7L18 Service

Fig. & Index No.	Tektronix Part No.	Serial/Model No. Eff	Dscont	Qty	1	2	3	4	5	Name & Description	Mfr Code	Mfr Part Number
3-131	-----	-----		1	.					RESISTOR, VAR: (SEE R2638 REPL) (ATTACHING PARTS)		
-132	210-0583-00			2	.					NUT, PLAIN, HEX: 0.25-32 X 0.312 INCH, BRS	73743	2X20317-402
-133	210-1010-00			1	.					WASHER, FLAT: 0.643 ID X 0.875 INCH OD	83385	OBD
										- - - * - - - -		
-134	333-2182-00	B010100	B020162	1	.					PANEL, FRONT: RF VERT	80009	333-2182-00
	333-2182-01	B020163		1	.					PANEL, FRONT:	80009	333-2182-01
-135	386-1447-83			1	.					SUBPANEL, FRONT: LEFT	80009	386-1447-83
										(ATTACHING PARTS)		
-136	213-0192-00			2	.					SCR, TPG, THD FOR: 6-32 X 0.50 INCH, PNH STL	87308	OBD
-137	211-0532-00			2	.					SCREW, MACHINE: 6-32 X 0.75 INCH, FILH STL	83385	OBD
-138	210-0561-00			2	.					NUT, PLAIN, HEX: 0.188 INCH L, 0.188 HEX BRS	80009	210-0561-00
-139	210-0407-00			2	.					NUT, PLAIN, HEX: 6-32 X 0.25 INCH, BRS	73743	3038-0228-402
										- - - * - - - -		
-140	348-0235-00			2	.					SHLD GSKT, ELEC: 4.734 INCH LONG	80009	348-0235-00
-141	426-1320-00			1	.					FR SECT, PLUG-IN: LOWER	80009	426-1320-00
-142	366-1257-62			1	.					PUSH BUTTON: SIL GY, 10 DB/DIV	80009	366-1257-62
-143	366-1257-61			1	.					PUSH BUTTON: SIL GY, 2 DB/DIV	80009	366-1257-61
-144	366-1257-89			1	.					PUSH BUTTON: SIL GY, LIN	80009	366-1257-89
-145	366-1257-00			1	.					PUSH BUTTON: GRAY PLASTIC	80009	366-1257-00
-146	-----			1	.					CKT BOARD ASSY: REF SUPPLIES (SEE A2316 REPL)		
-147	136-0252-04	B010100	B020499X	6	.					SOCKET, PIN TERM: U/W 0.016-0.018 DIA PINS	22526	75060-007
-148	136-0514-00	B010100	B020499X	2	.					SKT, PL-IN ELEC: MICROCIRCUIT, 8 DIP	73803	CS9002-8
-149	131-0608-00			6	.					TERMINAL, PIN: 0.365 L X 0.025 PH BRZ GOLD	22526	47357
-150	-----			1	.					CKT BOARD ASSY: DISPLAY MODE (SEE A2500 REPL) (ATTACHING PARTS)		
-151	211-0087-01			3	.					SCREW, MACHINE: 2-56 X 0.188, FLH 82 DEG, STL	83385	OBD
										- - - * - - - -		
	-----									CKT BOARD ASSY INCLUDES:		
-152	131-0608-00			16	.					TERMINAL, PIN: 0.365 L X 0.025 PH BRZ GOLD	22526	47357
-153	220-0785-00			1	.					NUT BLOCK: (2) 4-40 X 0.625 INCH LONG (ATTACHING PARTS)	80009	220-0785-00
-154	211-0101-00			2	.					SCREW, MACHINE: 4-40 X 0.25, 100 DEG, FLH STL	83385	OBD
										- - - * - - - -		
-155	346-0139-00			1	.					STRAP, RETAINING: YIG OSCILLATOR (ATTACHING PARTS)	80009	346-0139-00
-156	213-0038-00			2	.					SCREW, DRIVE: #0 X 0.125 INCH, STL	45722	OBD
										- - - * - - - -		
-157	386-3574-00			1	.					SUPPORT, YIG OSC: (ATTACHING PARTS)	80009	386-3574-00
-158	211-0541-00			2	.					SCREW, MACHINE: 6-32 X 0.25" 100 DEG, FLH STL	83385	OBD
										- - - * - - - -		
-159	361-0787-00			1	.					SPACER, PLATE: 0.05 X 1.5 X 1.0 INCH	80009	361-0787-00
-160	-----			1	.					OSCILLATOR, RF: W/CAN (SEE A2290 REPL)		
-161	-----			1	.					CKT BOARD ASSY: YIG OSC (SEE A2290A1 REPL)		
-162	136-0252-04			4	.					SOCKET, PIN TERM: U/W 0.016-0.018 DIA PINS	22526	75060-007
-163	131-0608-00			11	.					TERMINAL, PIN: 0.365 L X 0.025 PH BRZ GOLD	22526	47357
-164	129-0511-00			2	.					POST, ELEC-MECH: 0.35 " LONG, HEX BRS (ATTACHING PARTS FOR EACH)	80009	129-0511-00
-165	211-0180-00			1	.					SCR, ASSEM WSHR: 2-56 X 0.25 INCH, PNH BRS	83385	OBD
										- - - * - - - -		
-166	-----			1	.					TRANSISTOR: (SEE Q2200 REPL) (ATTACHING PARTS)		
-167	210-0406-00			1	.					NUT, PLAIN, HEX: 4-40 X 0.188 INCH, BRS	73743	12161-50
-168	211-0101-00			1	.					SCREW, MACHINE: 4-40 X 0.25, 100 DEG, FLH STL	83385	OBD
										- - - * - - - -		
-169	-----			1	.					TRANSISTOR: (SEE Q2080 REPL) (ATTACHING PARTS)		
-170	210-0405-00			1	.					NUT, PLAIN, HEX: 2-56 X 0.188 INCH, BRS	73743	12157-50
-171	210-1178-00			1	.					WASHER, SHLDR: U/W T0-220 TRANSISTOR	49671	DF137A
-172	211-0101-00			1	.					SCREW, MACHINE: 4-40 X 0.25, 100 DEG, FLH STL	83385	OBD
										- - - * - - - -		
-173	342-0202-00			2	.					INSULATOR, PLATE: TRANSISTOR	01295	10-21-023-106
-174	426-1319-00			1	.					FR SECT, PLUG-IN: UPPER	80009	426-1319-00

Replaceable Mechanical Parts—7L18 Service

Fig. & Index No.	Tektronix Part No.	Serial/Model No. Eff Dscont	Qty	1	2	3	4	5	Name & Description	Mfr Code	Mfr Part Number
3-	198-3139-00		1						WIRE KIT,ELEC:	80009	198-3139-00
-175	175-0825-00		FT	.					WIRE,ELECTRICAL:2 WIRE RIBBON	80009	175-0825-00
-176	175-0826-00		FT	.					WIRE,ELECTRICAL:3 WIRE RIBBON	80009	175-0826-00
-177	175-0827-00		FT	.					CABLE,SP,ELEC:4,26 AWG,STRD,PVC JKT,RBN	08261	SS04267(1061)0C
-178	175-0828-00		FT	.					WIRE,ELECTRICAL:5 WIRE RIBBON	08261	SS-0526-710610C
-179	175-0829-00		FT	.					WIRE,ELECTRICAL:6 WIRE RIBBON	08261	SS-0626-710610C
-180	175-0830-00		FT	.					WIRE,ELECTRICAL:7 WIRE RIBBON	08261	SS-0726-710610C
-181	352-0169-00		1	.					HLDR,TERM CONN:2 WIRE BLACK	80009	352-0169-00
	352-0169-02		1	.					CONN BODY,PL,EL:2 WIRE RED	80009	352-0169-00
	352-0169-03		2	.					CONN BODY,PL,EL:2 WIRE ORANGE	80009	352-0169-03
	352-0169-06		1	.					CONN BODY,PL,EL:2 WIRE BLUE	80009	352-0169-06
	352-0169-07		1	.					CONN BODY,PL,EL:2 WIRE PURPLE	80009	352-0169-07
	352-0169-09		1	.					CONN BODY,PL,EL:2 WIRE WHITE	80009	352-0169-09
-182	352-0161-00		2	.					HLDR,TERM CONN:3 WIRE,BLACK	80009	352-0161-00
	352-0161-01		2	.					CONN BODY,PL,EL:3 WIRE BROWN	80009	352-0161-01
	352-0161-05		1	.					CONN BODY,PL,EL:3 WIRE GREEN	80009	352-0161-05
-183	352-0162-00		2	.					HLDR,TERM CONN:4 WIRE BLACK	80009	352-0162-00
	352-0162-02		1	.					CONN BODY,PL,EL:4 WIRE RED	80009	352-0162-02
-184	352-0163-05		1	.					CONN BODY,PL,EL:5 WIRE GREEN	80009	352-0163-05
-185	352-0164-00		2	.					CONN BODY,PL,EL:6 WIRE BLACK	80009	352-0164-00
	352-0164-06		2	.					CONN BODY,PL,EL:6 WIRE BLUE	80009	352-0164-06
	352-0164-07		2	.					HLDR,TERM CONN:6 WIRE VIOLET	80009	352-0164-07
-186	352-0165-08		2	.					CONN BODY,PL,EL:7 WIRE GRAY	80009	352-0165-08
-187	131-0707-00		93	.					CONNECTOR,TERM:22-26 AWG,BRS& CU BE GOLD	22526	47439
	198-3136-00		1	.					WIRE KIT,ELEC:	80009	198-3136-00
	131-0707-00		8	.					CONNECTOR,TERM:22-26 AWG,BRS& CU BE GOLD	22526	47439
	175-0826-00		FT	.					WIRE,ELECTRICAL:3 WIRE RIBBON	80009	175-0826-00
	175-0828-00		FT	.					WIRE,ELECTRICAL:5 WIRE RIBBON	08261	SS-0526-710610C
	352-0161-00		1	.					HLDR,TERM CONN:3 WIRE,BLACK	80009	352-0161-00
	352-0163-00		1	.					CONN BODY,PL,EL:5 WIRE BLACK	80009	352-0163-00
	198-3370-00		1	.					WIRE KIT,ELEC:	80009	198-3370-00

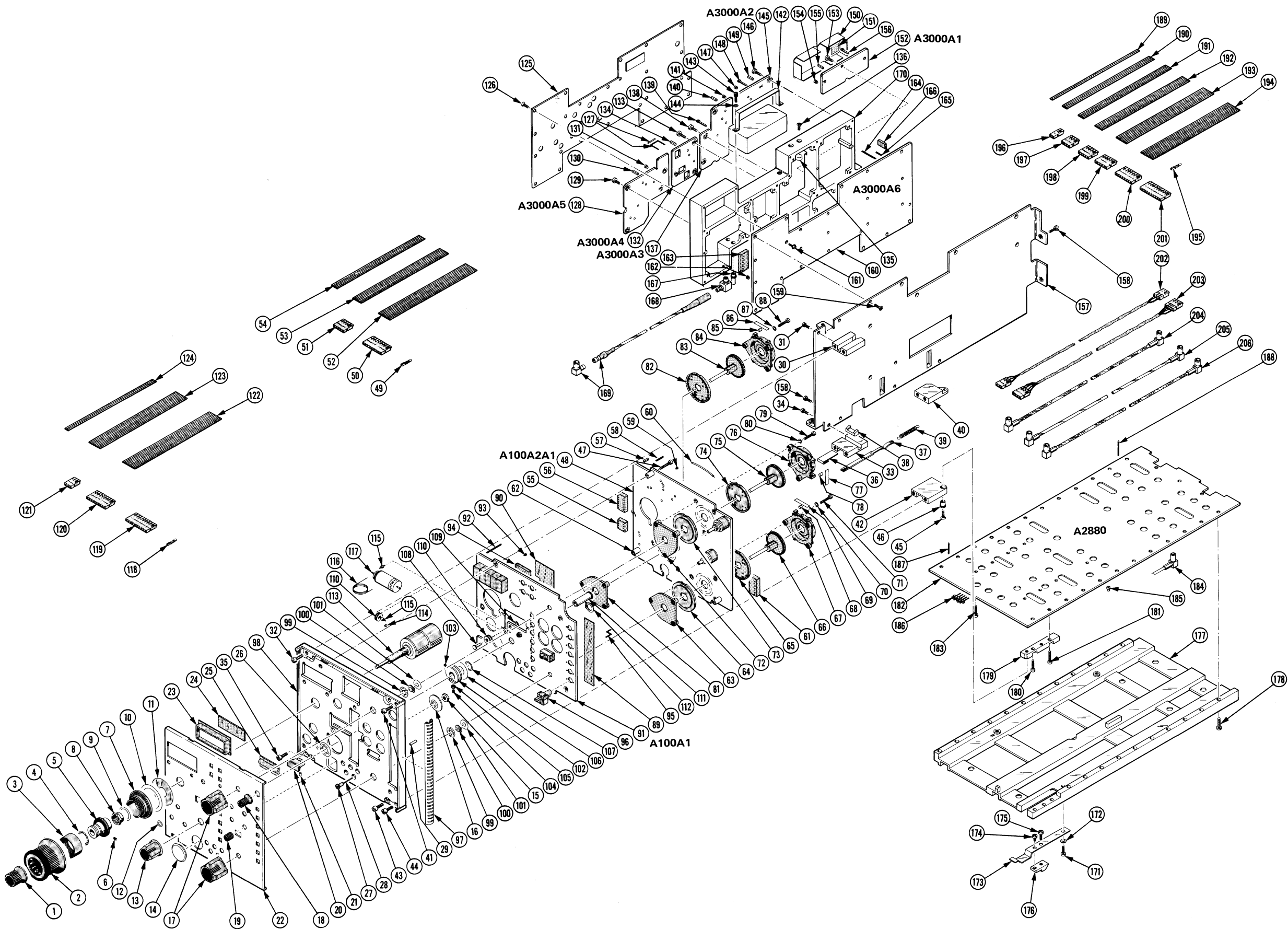

7L18 SPECTRUM ANALYZER

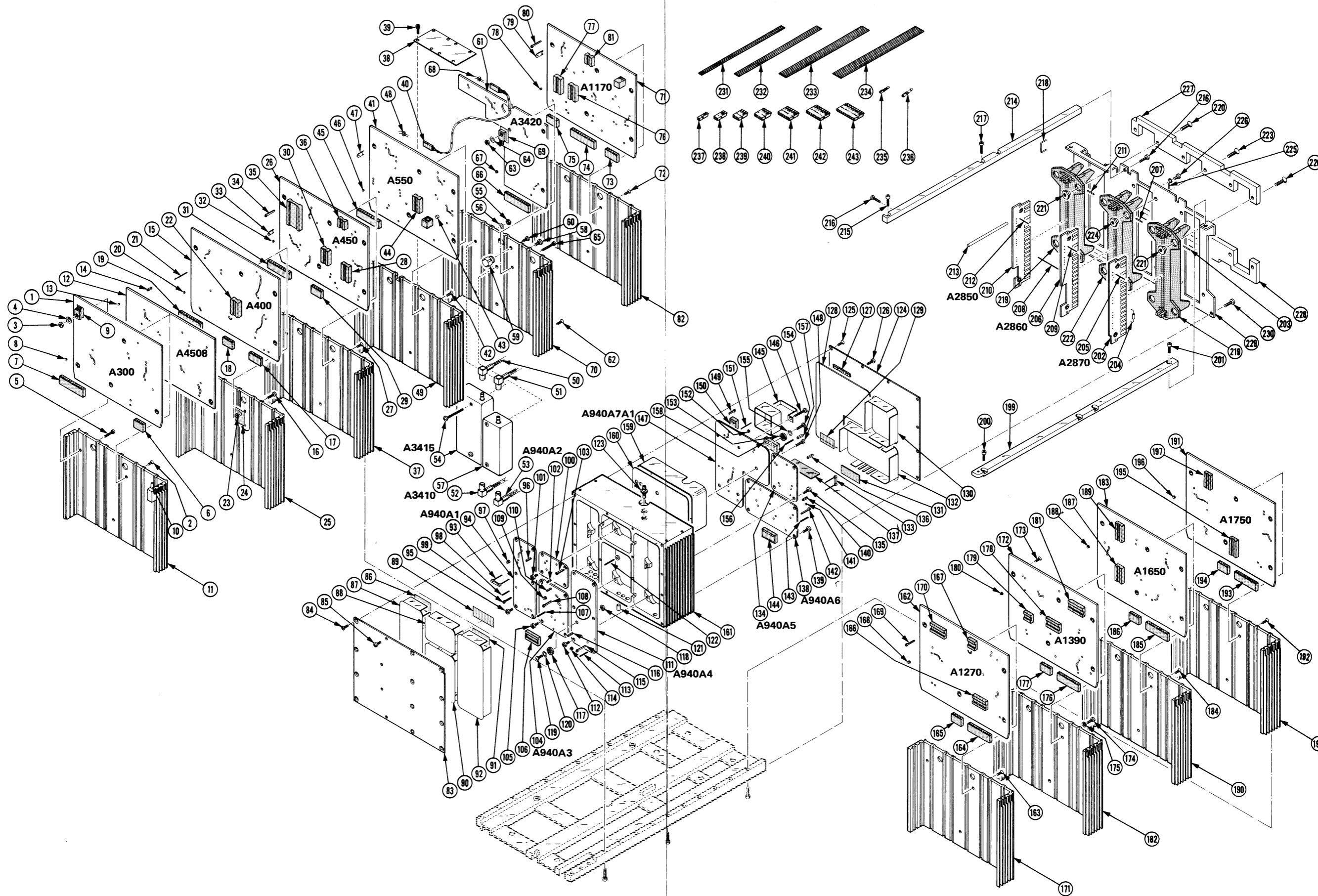

7L18 SPECTRUM ANALYZER

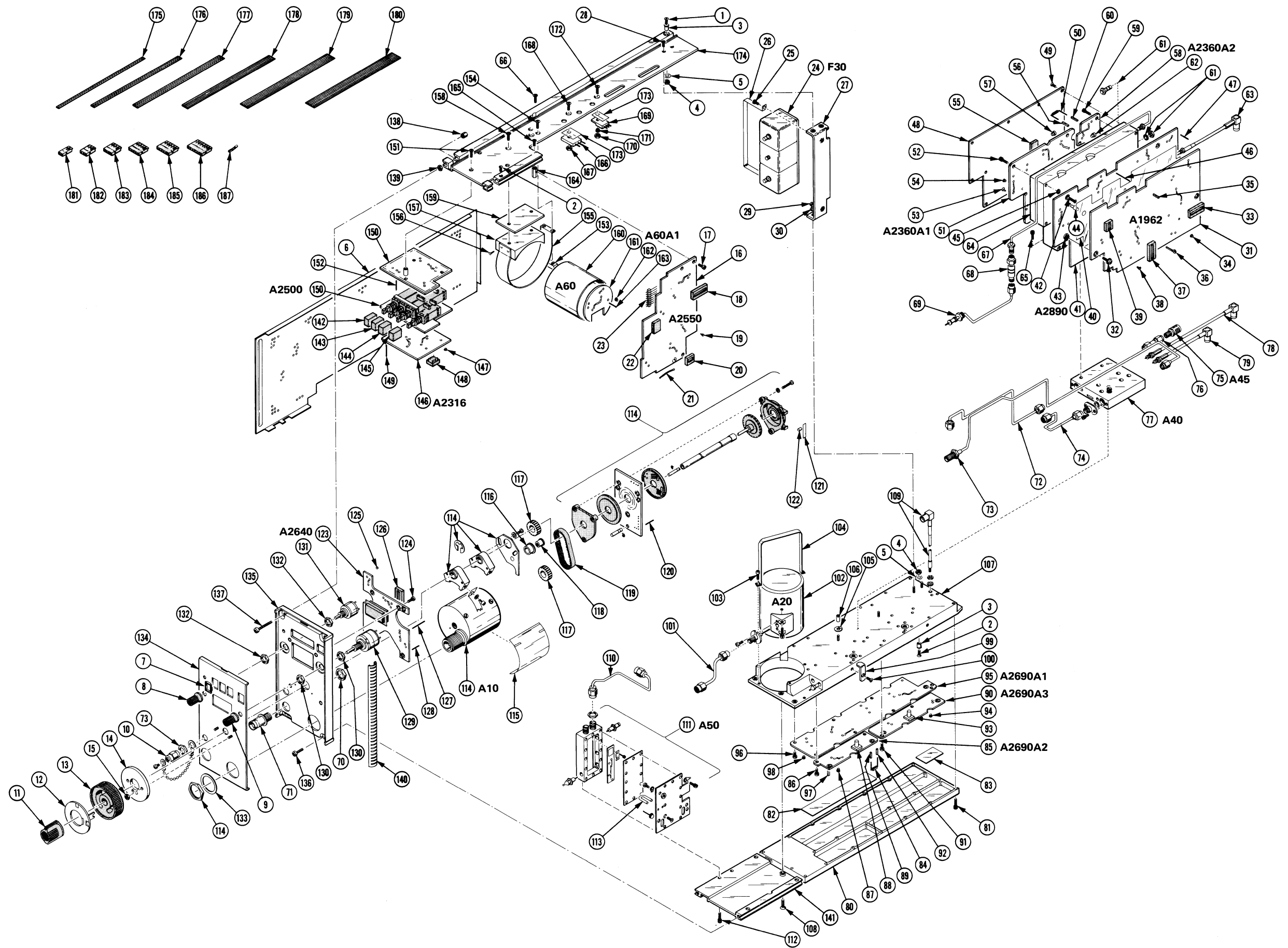

FIG 3 VERTICAL ASSEMBLY

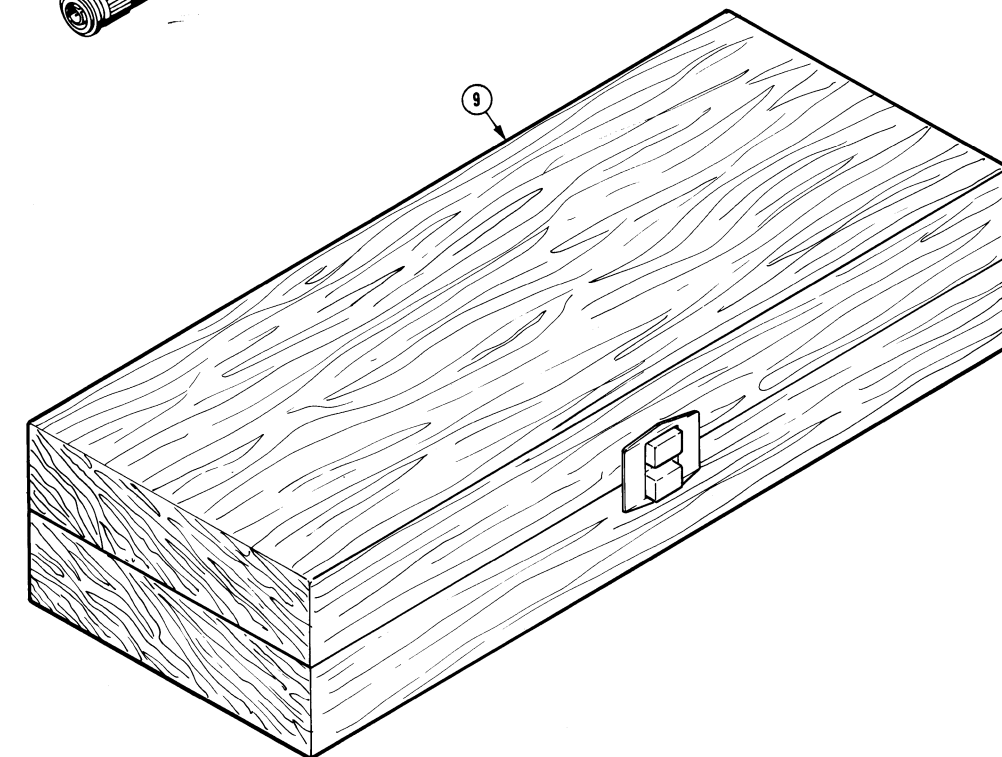
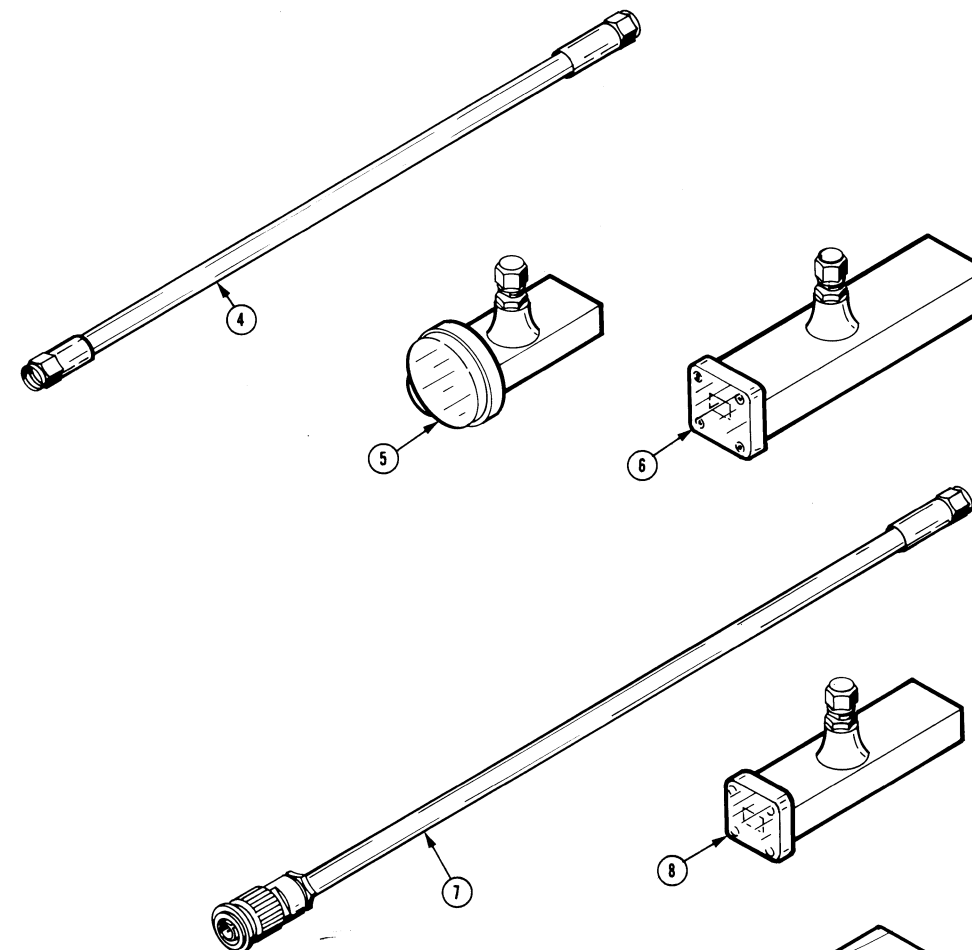
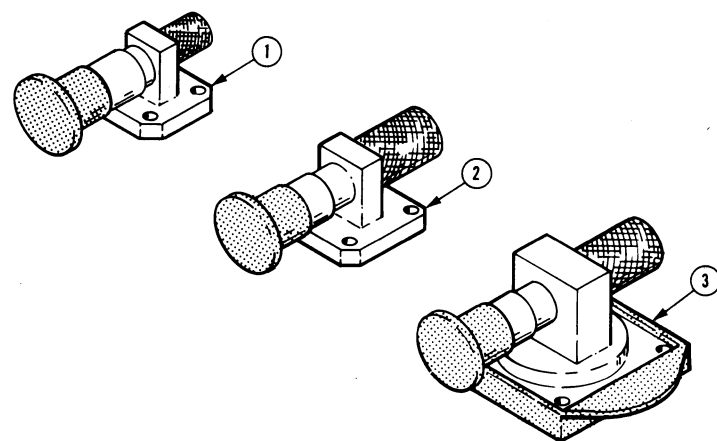

Fig. & Index No.	Tektronix Part No.	Serial/Model No. Eff	Dscont	Qty	1	2	3	4	5	Name & Description	Mfr Code	Mfr Part Number
OPTION 20												
4-1	119-0099-00			1						MIXER,XTAL,WG:26.5-40.0 GHZ	80009	119-0099-00
-2	119-0098-00			1						MIXER,XTAL,WG:18.0-26.5 GHZ	80009	119-0098-00
-3	119-0097-00			1						MIXER,XTAL,WG:12.4-18.0 GHZ	80009	119-0097-00
-4	012-0748-00			1						CABLE,INTCON:28.5 L	19505	80-9901-202
OPTION 21												
-5	WM490-2 WM490K			1						WG MIXER SET:HI PERFORMANCE 18-40 GHZ	80009	WM490-2
-6	WM490A			1						. WAVEGUIDE MIXER:18 TO 26.5 GHZ - . (SEE 070-3731-00 MANUAL FOR PARTS BKDN)	80009	WM490K
-7	012-0649-00 016-0465-01 070-3731-00			1						. WAVEGUIDE MIXER:26.5 TO 40 GHZ - . (SEE 070-3731-00 MANUAL FOR PARTS BKDN)	80009	WM490A
				1						CABLE ASSY,RF:50 OHM COAX,28.5 INCH LONG	80009	012-0649-00
				1						CASE STORAGE:12.5 X 4.68 X 2.75,WOOD	80009	016-0465-01
				1						MANUAL,TECH:INSTRUCTION	80009	070-3731-00
OPTION 22												
-8	WM490-3 WM490K			1						WG MIXER SET:HI PERFORMANCE,18 TO 60 GHZ	80009	WM490-3
	WM490A			1						. WAVEGUIDE MIXER:18 TO 26.5GHZ - . (SEE 070-3731-00 MANUAL FOR PARTS BKDN)	80009	WM490K
				1						. WAVEGUIDE MIXER:26.5 TO 40GHZ - . (SEE 070-3731-00 MANUAL FOR PARTS BKDN)	80009	WM490A
				1						WAVE GUIDE MIXER:40 TO 60GHZ	80009	WM490U
-9	012-0649-00 016-0465-01 070-3731-00			1						CABLE ASSY,RF:50 OHM COAX,28.5 INCH LONG	80009	012-0649-00
				1						CASE STORAGE:12.5 X 4.68 X 2.75,WOOD	80009	016-0465-01
				1						MANUAL,TECH:INSTRUCTION	80009	070-3731-00

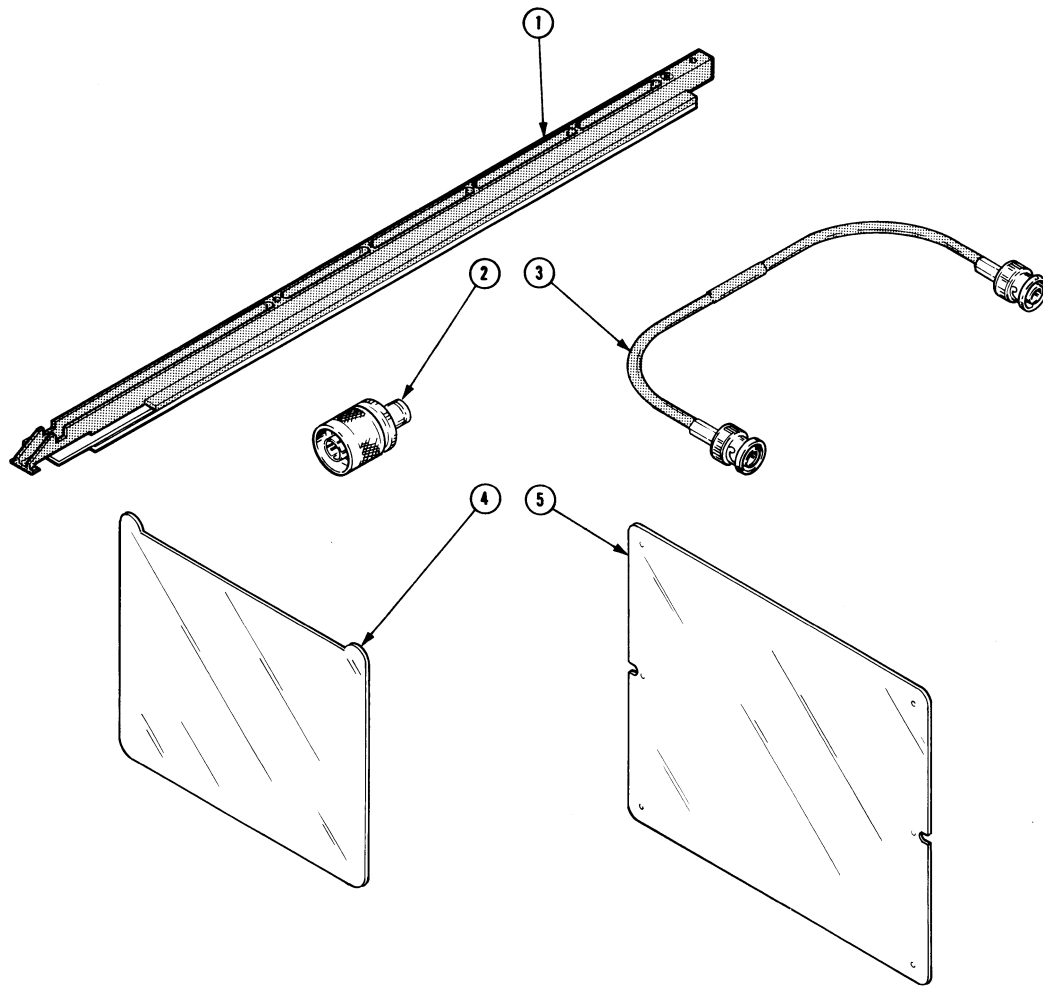

Fig. & Index No.	Tektronix Part No.	Serial/Model No.		Qty						Name & Description	Mfr Code	Mfr Part Number
		Eff	Dscont		1	2	3	4	5			
-1	016-0637-00			1							80009	016-0637-00
-2	103-0045-00			1							91836	KN99-35
-3	012-0208-00			1							80009	012-0208-00
-4	337-1159-02			1							80009	337-1159-02
-5	337-1439-01			1							80009	337-1439-01
	070-2295-00			1							80009	070-2295-00
	070-2339-00			1							80009	070-2339-00

MANUAL CHANGE INFORMATION

At Tektronix, we continually strive to keep up with latest electronic developments by adding circuit and component improvements to our instruments as soon as they are developed and tested.

Sometimes, due to printing and shipping requirements, we can't get these changes immediately into printed manuals. Hence, your manual may contain new change information on following pages.

A single change may affect several sections. Since the change information sheets are carried in the manual until all changes are permanently entered, some duplication may occur. If no such change pages appear following this page, your manual is correct as printed.

DESCRIPTION

EFF SN B010440

SCHEMATIC CORRECTION

Add a diode CR1546 from pin 4 to pin 3 of U1545, cathode to pin 4. Add a diode CR1548 from pin 11 to pin 8 of U1545, cathode to pin 11. The above parts are added to the A1390 TRIGGER, SWEEP & HORIZONTAL AMPLIFIER board and shown on

Diagram 11 HORIZONTAL SWEEP - Partial

