

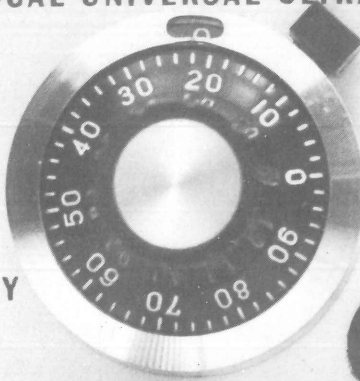





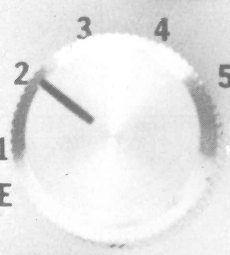
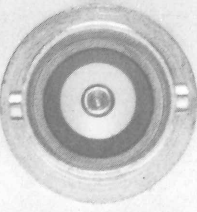
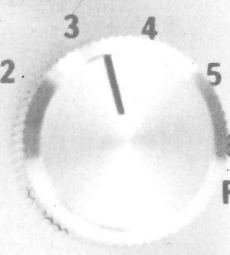
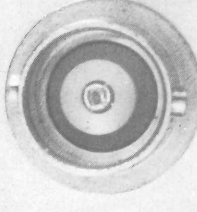

DUAL UNIVERSAL ULTRASONIC WINDOW GENERATOR

DELAY  POWER  WIDTH

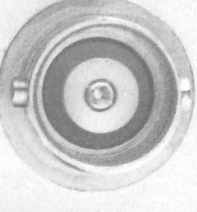
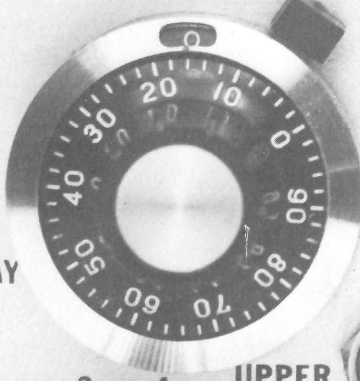
RANGE  SYNC. IN  RANGE 

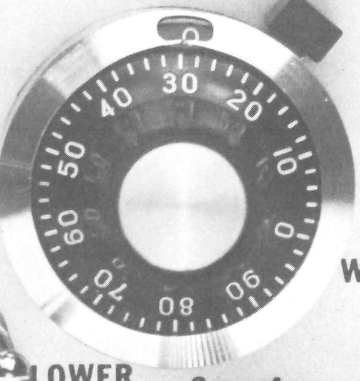
GATE OUT  WIDTH ONLY  DELAY AND WIDTH  GATE OUT

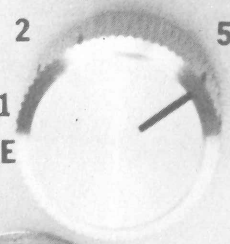
DELAY  OFF  LOWER  WIDTH

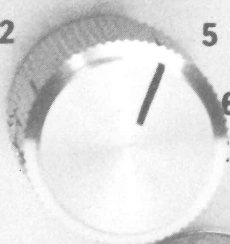
RANGE  UPPER  Z-AXIS  DELAY AND WIDTH  RANGE

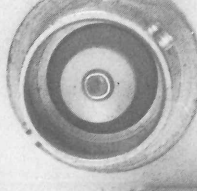
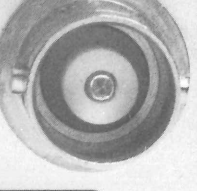
GATE OUT  GATE OUT 

TEKTRONIX

106-013

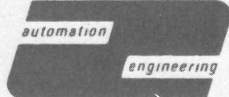

MODEL AE-106



THEORY OF OPERATION

for

DUAL UNIVERSAL ULTRASONIC WINDOW GENERATOR

Model No. AE 106

The gate outputs of the window generator are driven by an adjustable monostable multivibrator (one shot). In the "width only" mode this one shot (IC 2, 4) is triggered by the positive going edge of the sync input. The pulse width is varied by the width selector switch, which changes the timing capacitor, and the width vernier potentiometer, which changes the timing resistance. In addition, the small trimmer capacitor on the right side varies the width in switch position 1, the shortest range.

In the "Width and Delay" mode the sync input is switched to the delay one shot IC 1, 3. The positive going edge of the sync pulse triggers IC 1, 3. The delay width is varied by the delay selector switch, which changes the timing capacitor, and the delay vernier pot, which changes the timing resistance. In addition, the small trimmer capacitor on the left side varies the delay in switch position 1, the shortest range. After timing out the negative going edge of the delay pulse triggers the input of the width IC 2, 4. The width of the delayed pulse is adjusted in the same manner as in paragraph above.

VR 1 provides the necessary regulated +5 V DC to provide power for the ICs.

OPERATING INSTRUCTIONS

for

DUAL UNIVERSAL ULTRASONIC WINDOW GENERATOR

Model No. AE 106

For purposes of discussion, only one section will be explained. The upper and lower sections are identical.

- A. Connect the trigger source to the "Sync In" input. This should be a TTL level pulse train of the desired repetition rate.
- B. Select "Width only" for output pulses triggered from positive going edge of sync input or "Delay and Width" for delayed pulses.
- C. Width: adjust width of output pulse for "Width" selector switch (Positions 1-5, pos. 6 is used for customer option) and "Width" vernier potentiometer. In addition the small trimmer capacitor on the right side varies the width in switch position 1.
- D. Delay and Width: adjust delay of output pulse with "Delay" selector switch (positions 1-5, pos. 6 is used for customer option) and "Delay" vernier potentiometer. In addition, small trimmer capacitor on left side varies delay in switch position 1.
- E. Width of delayed pulse is adjusted in the same manner as a normal pulse.
- F. Both "Gate Out" outputs per section are identical.
- G. Z Axis: upper position on Z axis switch connects upper outputs to Z axis output. Lower position on Z axis switch connects lower outputs to Z axis output. Center position disables Z axis output.

SPECIFICATIONS

for

DUAL UNIVERSAL ULTRASONIC WINDOW GENERATOR

Model No. AE 106

POWER INPUT

Voltage: +11.5 v DC (from TM500 mainframe)
Current: 100 ma maximum; 90 ma nominal

SYNC INPUT

Level: TTL compatible (low level: 0-.8v
high level: 2.0-5.0v)
Fan in: 2 TTL loads
Pulse width: 50 ns minimum
Repetition rate: 10 mhz maximum

OUTPUTS

Gate out: TTL compatible) Low Level: 0-.4v
Z Axis: TTL compatible) High Level: 2.4-5.0v
Fan Out: 10 per section (total of Gate Outs and
Z axis.)

Pulse Width: continuously adjustable

Range 1:	60 ns	300 ns
2:	100 ns	3.0 microsec
3:	1.0 microsec	30 microsec
4:	10 microsec	275 microsec
5:	100 microsec	2.9 ms
6:	customer option	

Pulse Delay: continuously adjustable

Range 1:	60 ns	300 ns
2:	180 ns	3.0 microsec
3:	1.1 microsec	30 microsec
4:	10 microsec	275 microsec
5:	100 microsec	2.9 ms
6:	customer option	

DIMENSIONS

2.50"w x 4.75"h x 10.0"d
6.35cm x 11.88cm x 25.4cm
(Standard TM-500 module)

WEIGHT

1 lb. 11.5 oz. (781 g.)

WARRANTY

for

DUAL UNIVERSAL ULTRASONIC WINDOW GENERATOR

Model No. AE 106

Automation Engineering, Inc. guarantees the Dual Universal Window Generator against defects in material and workmanship for a period of 90 days after date of shipment from factory.

Any defective units covered by warranty should be returned to:

Automation Engineering, Inc.
3621 Marine Dr.
Toledo, Ohio 43609

This Warranty applies only to original owner of this item. Contact factory for return authorization before shipping any defective items.

Factory service is available for repair parts and service after warranty.

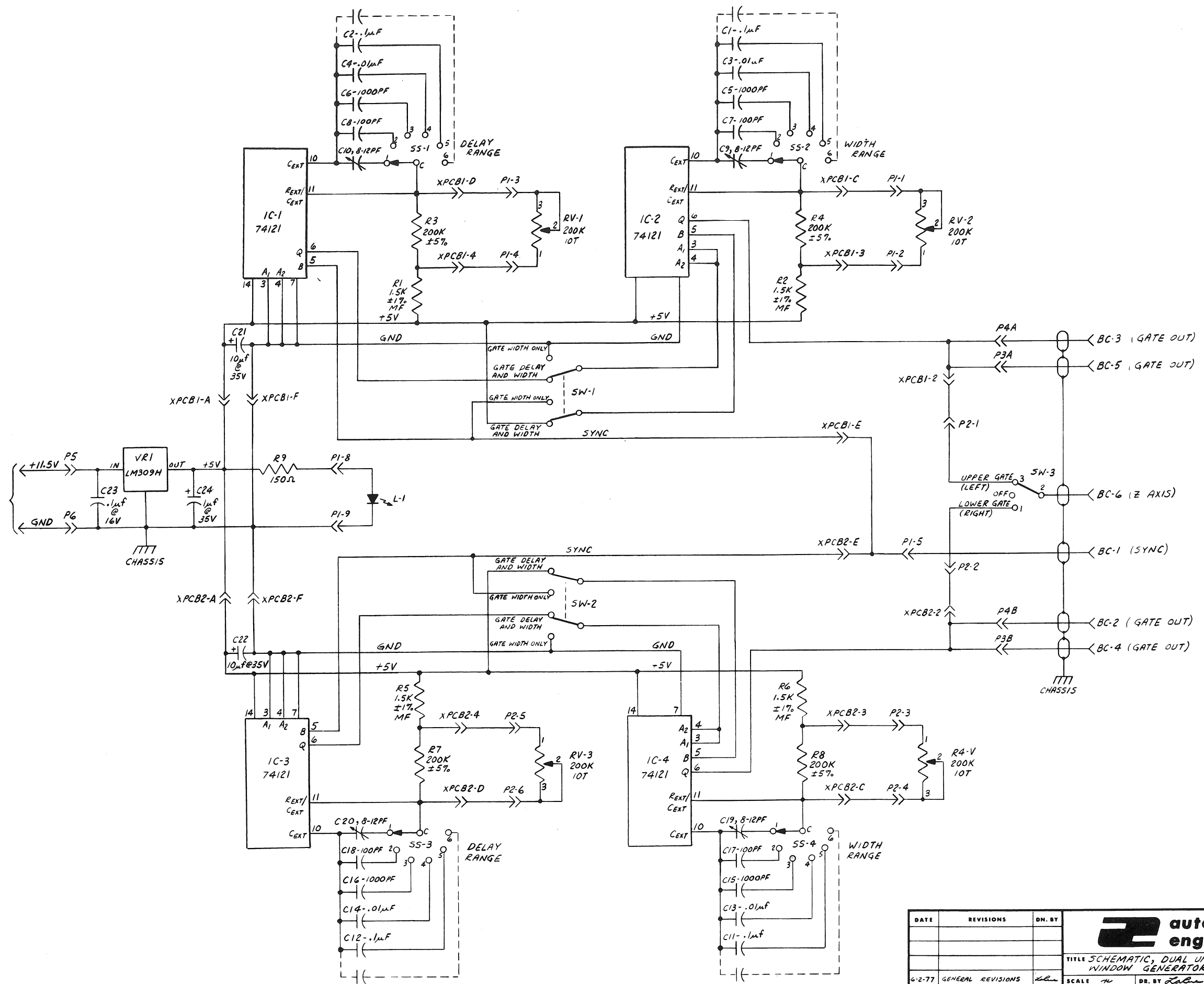

DATE	REVISIONS	DN. BY	automation engineering		
			TITLE SCHEMATIC, DUAL UNIVERSAL ULTRASONIC WINDOW GENERATOR		
6-2-77	GENERAL REVISIONS	slu	SCALE 1/4"	DR. BY Kaban	DWG. NO.
4-18-77	SW-1 & SW-2 POSITION TERMINOLOGY REVISED	slu	DATE 11-11-76	CK'D. BY	AEC-269