



RF Power Transistors

2N3478



SILICON N-P-N EPITAXIAL PLANAR TRANSISTOR

For VHF/UHF Applications
in Industrial and Commercial Equipment

Features:

- high gain-bandwidth product – $f_T = 900\text{ MHz typ.}$
- low noise figure
 $NF = 5\text{ dB typ. at } 470\text{ MHz}$
 $4.5\text{ dB max. at } 200\text{ MHz}$
 $2.5\text{ dB typ. at } 60\text{ MHz}$
- high unneutralized power gain
 $G_{pe} = 11.5\text{ dB min. at } 200\text{ MHz}$
- hermetically sealed four-lead package
- all active elements insulated from case
- low collector-to-base feedback capacitance, $C_{cb} 0.7\text{ pF max.}$

RCA-2N3478 is an epitaxial planar transistor of the silicon n-p-n type with characteristics which make it extremely useful as a general purpose rf amplifier at frequencies up to 470MHz. These characteristics include an exceptionally low noise figure at high frequencies, low leakage current, and a high gain-bandwidth product.

The 2N3478 utilizes a hermetically sealed four-lead package in which active elements of the transistor are insulated from the case. The case may be grounded by means of a fourth lead in applications requiring minimum feedback capacitance, shielding of the device, or both.

Maximum Ratings, Absolute-Maximum Values:

Collector-to-Base Voltage, V_{CBO}	30 max.	V
Collector-to-Emitter Voltage, V_{CEO}	15 max.	V
Emitter-to-Base Voltage, V_{EBO}	2 max.	V
Collector Current, I_C	limited by dissipation	
Transistor Dissipation, P_T :		
at ambient } up to 25°C	200 max.	mW
temperatures } above 25°C	See Fig. 1	
Temperature Range:		
Storage and Operating (Junction)	-65 to 200	$^\circ\text{C}$
Lead Temperature (During Soldering):		
At distances not closer than 1/32" to seating surface for 10 seconds max.	265 max.	$^\circ\text{C}$

ELECTRICAL CHARACTERISTICS, At an Ambient Temperature (T_A) of 25°C

Characteristics	Symbols	TEST CONDITIONS					LIMITS			Units
		Frequency f	DC Collector- to-Base Voltage V_{CB}	DC Collector- to-Emitter Voltage V_{CE}	DC Emitter Current I_E	DC Collector Current I_C	Type 2N3478			
		MHz	V	V	mA	mA	Min.	Typ.	Max.	
Collector-Cutoff Current	I_{CBO}		1		0		-	-	0.02	μA
Collector-to-Base Breakdown Voltage	BV_{CBO}				0	0.001	30	-	-	V
Collector-to-Emitter Breakdown Voltage	BV_{CEO}					0.001	15	-	-	V
Emitter-to-Base Breakdown Voltage	BV_{EBO}				-0.001	0	2	-	-	V
Static Forward-Current Transfer Ratio	h_{FE}			8		2	25	-	150	
Magnitude of Small-Signal Forward-Current Transfer Ratio	h_{fe}^a	100		8		2	7.5	9	16	
Collector-to-Base Feedback Capacitance	C_{cb}^b	1	10		0		-	-	1	pF
Small-Signal, Common-Emitter Power Gain in Unneutralized Amplifier Circuit (See Fig. 3)	G_{pe}^a	200		8		2	11.5	-	17	dB
Small-Signal, Common-Emitter Power Gain in Neutralized Amplifier Circuit	$G_{pe}^{a,c}$	470		6		1.5	-	12	-	dB
UHF Noise Figure	$NF^{a,c}$	470		6		1.5	-	5	-	dB
VHF Noise Figure (See Fig. 3)	NF^a $NF^{a,d}$	200 60		8 8		2 1	- -	- 2.5	4.5 -	dB dB

^a Fourth lead (case) grounded.

^b C_{cb} is a three terminal measurement of the collector-to-base capacitance with the emitter and case connected to the guard terminal.

^c Source Resistance, $R_s = 50$ ohms.

^d Source Resistance, $R_s = 400$ ohms.

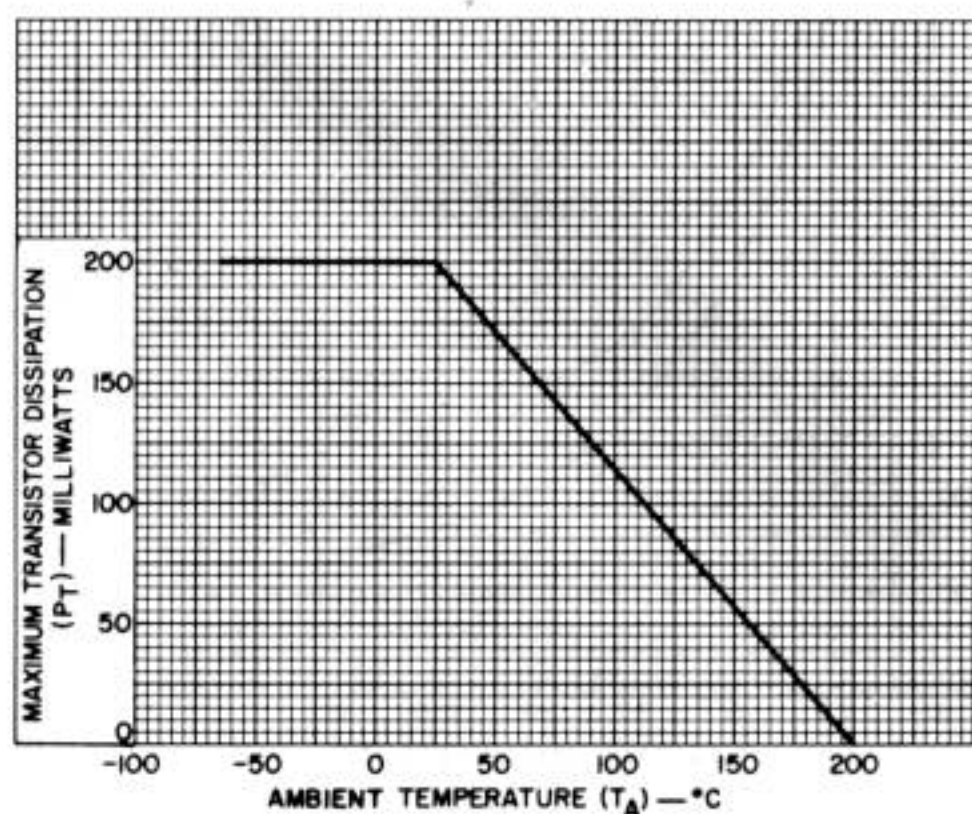

Fig. 1 - Rating chart for type 2N3478

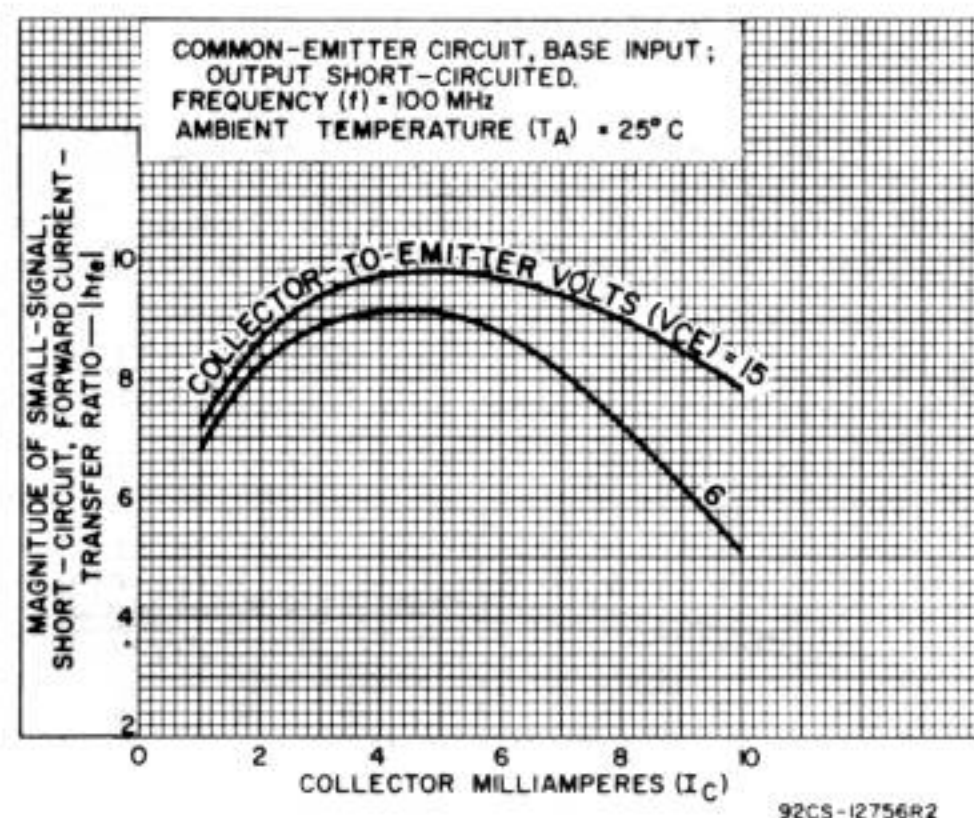
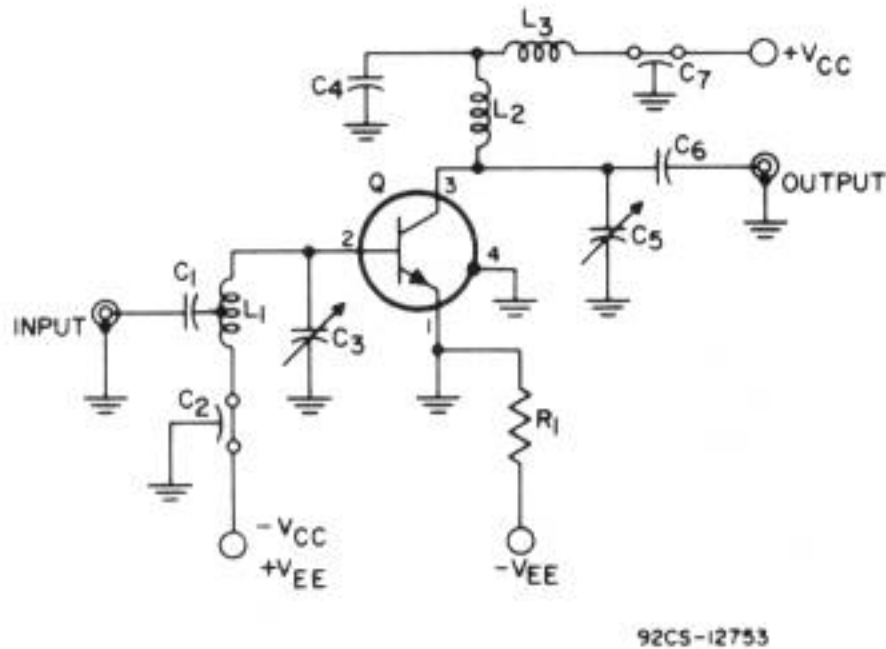

Fig. 2 - Typical small-signal beta characteristics for type 2N3478



92CS-12753

- $C_1, C_4 = 510 \text{ pF}$
- $C_2, C_7 = 2300 \text{ pF}$
- $C_3, C_5 = 2-25 \text{ pF}$
- $C_6 = 10 \text{ pF}$
- $R_1 = 2000 \text{ ohms}$
- $Q = 2N3478$
- $L_1 = \frac{1}{2} \text{ Turn \# 14 Formvar center tapped}$
- Length₁, $l_1 = 2 \text{ inches}$
- $L_2 = \frac{1}{2} \text{ Turn \# 14 Formvar}$
- Length₂, $l_2 = 1 \frac{1}{2} \text{ inches}$
- $L_3 = 1 \mu\text{H RRF choke}$
- Source (Generator) Resistance
- $R_g = 50 \text{ ohms}$
- Load Resistance $R_L = 50 \text{ ohms}$
- Trademark, Shawindian Products Corporation.

Fig. 3 - 200 MHz power gain and noise figure test circuit for type 2N3478

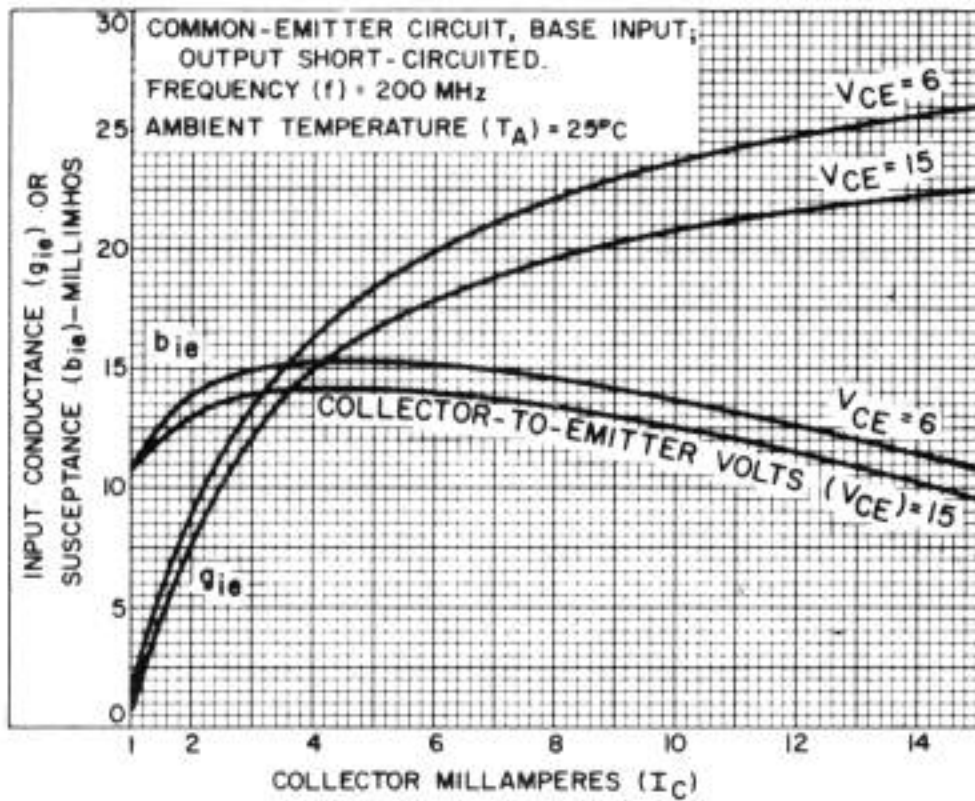

92CS-12757RI

Fig. 4 - Input admittance (y_{ie})

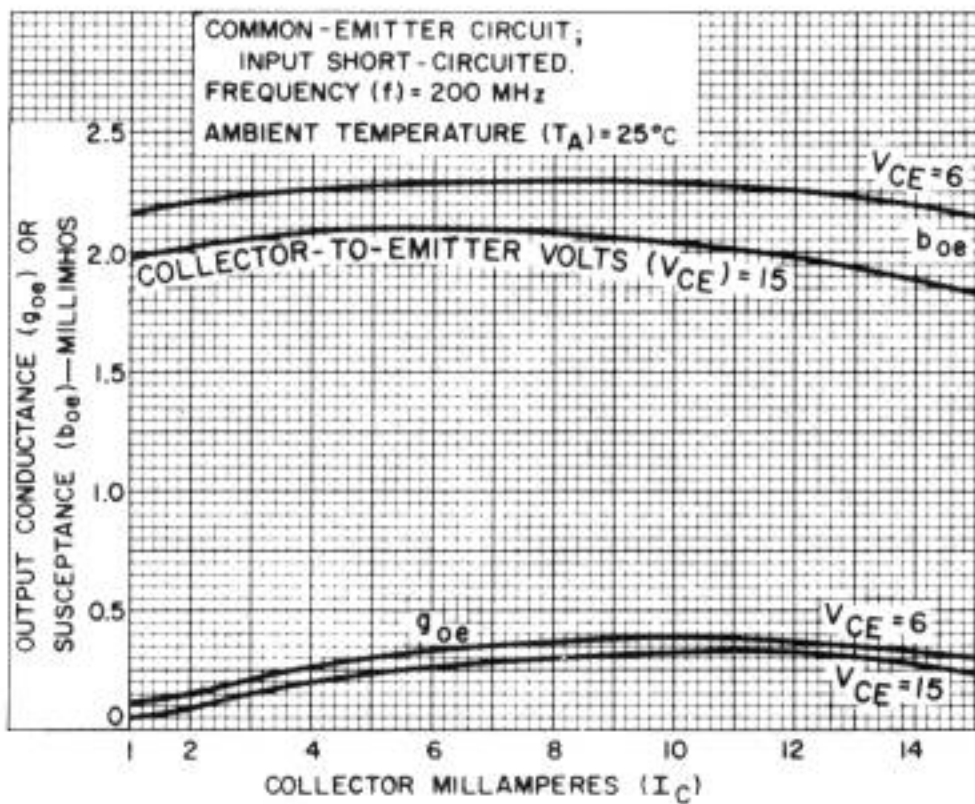

92CS-12758RI

Fig. 5 - Output admittance (y_{oe})

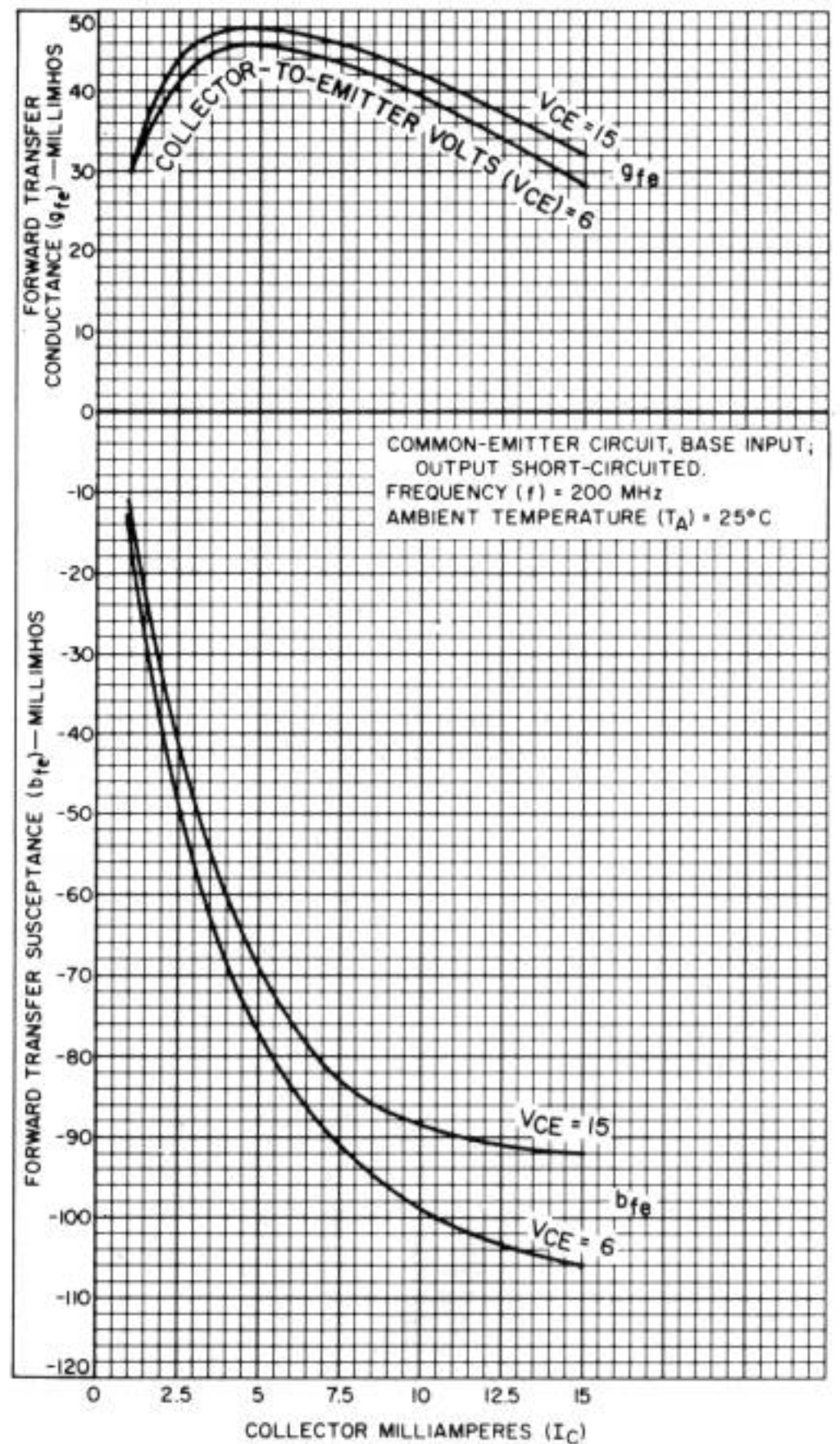

92CM-14172

Fig. 6 - Forward transadmittance (y_{fe})

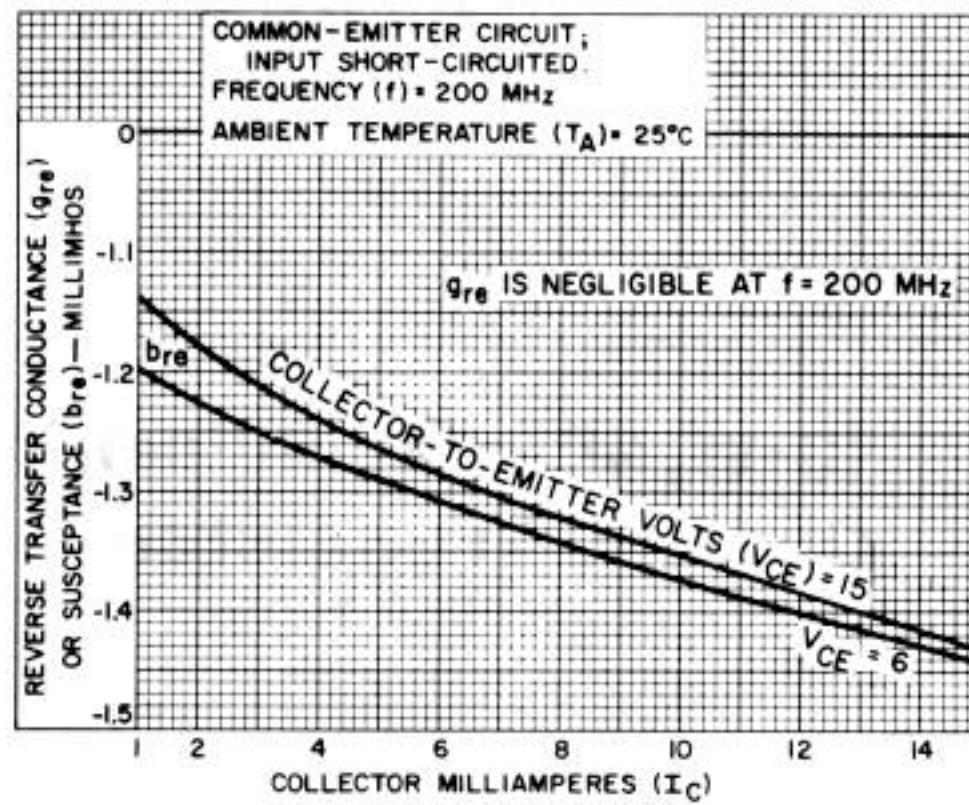

92CS-12760R1

Fig. 7 - Reverse transmittance (y_{re})

DIMENSIONAL OUTLINE

JEDEC TO-72

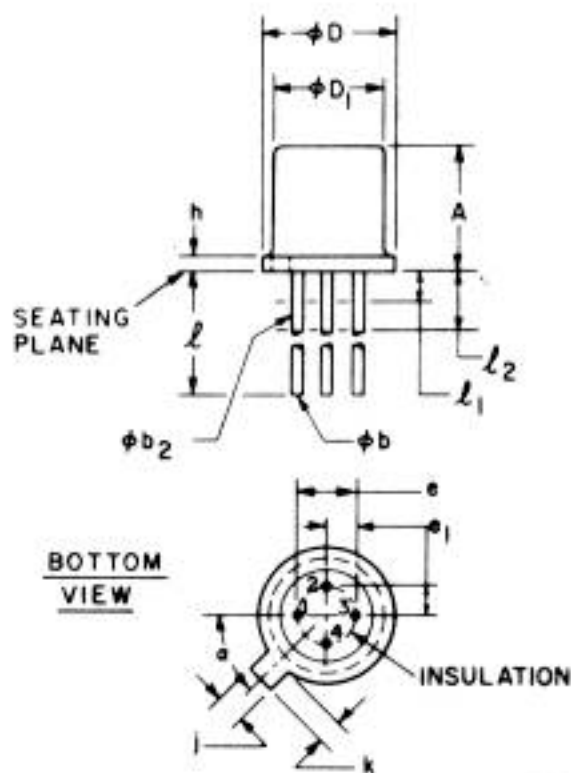

92CS-17444 R1

TERMINAL CONNECTIONS

- Lead 1 – Emitter
- Lead 2 – Base
- Lead 3 – Collector
- Lead 4 – Connected to case

SYMBOL	INCHES		MILLIMETERS		NOTES
	MIN.	MAX.	MIN.	MAX.	
A	0.170	0.210	4.32	5.33	
ϕb	0.016	0.021	0.406	0.533	2
ϕb_2	0.016	0.019	0.406	0.483	2
ϕD	0.209	0.230	5.31	5.84	
ϕD_1	0.178	0.195	4.52	4.95	
e	0.100 T.P.		2.54 T.P.		4
e1	0.050 T.P.		1.27 T.P.		4
h		0.030		0.762	
i	0.036	0.046	0.914	1.17	
k	0.028	0.048	0.711	1.22	3
l	0.500		12.70		2
l_1		0.050		1.27	2
l_2	0.250		6.35		2
a	45° T.P.		45° T.P.		4, 6

Note 1: (Four leads). Maximum number leads omitted in this outline, "none" (0). The number and position of leads actually present are indicated in the product registration. Outline designation determined by the location and minimum angular or linear spacing of any two adjacent leads.

Note 2: (All leads) ϕb_2 applies between l_1 and l_2 . ϕb applies between l_2 and 0.50 in. (12.70 mm) from seating plane. Diameter is uncontrolled in l_1 and beyond 0.50 in. (12.70 mm) from seating plane.

Note 3: Measured from maximum diameter of the product.

Note 4: Leads having maximum diameter 0.019 in. (0.484 mm) measured in gaging plane 0.054 in. (1.37 mm) +0.001 in. (0.025 mm) -0.000 in. (0.000 mm) below the seating plane of the product shall be within 0.007 in. (0.178 mm) of their true position relative to a maximum width tab.

Note 5: The product may be measured by direct methods or by gage.

Note 6: Tab centerline.