

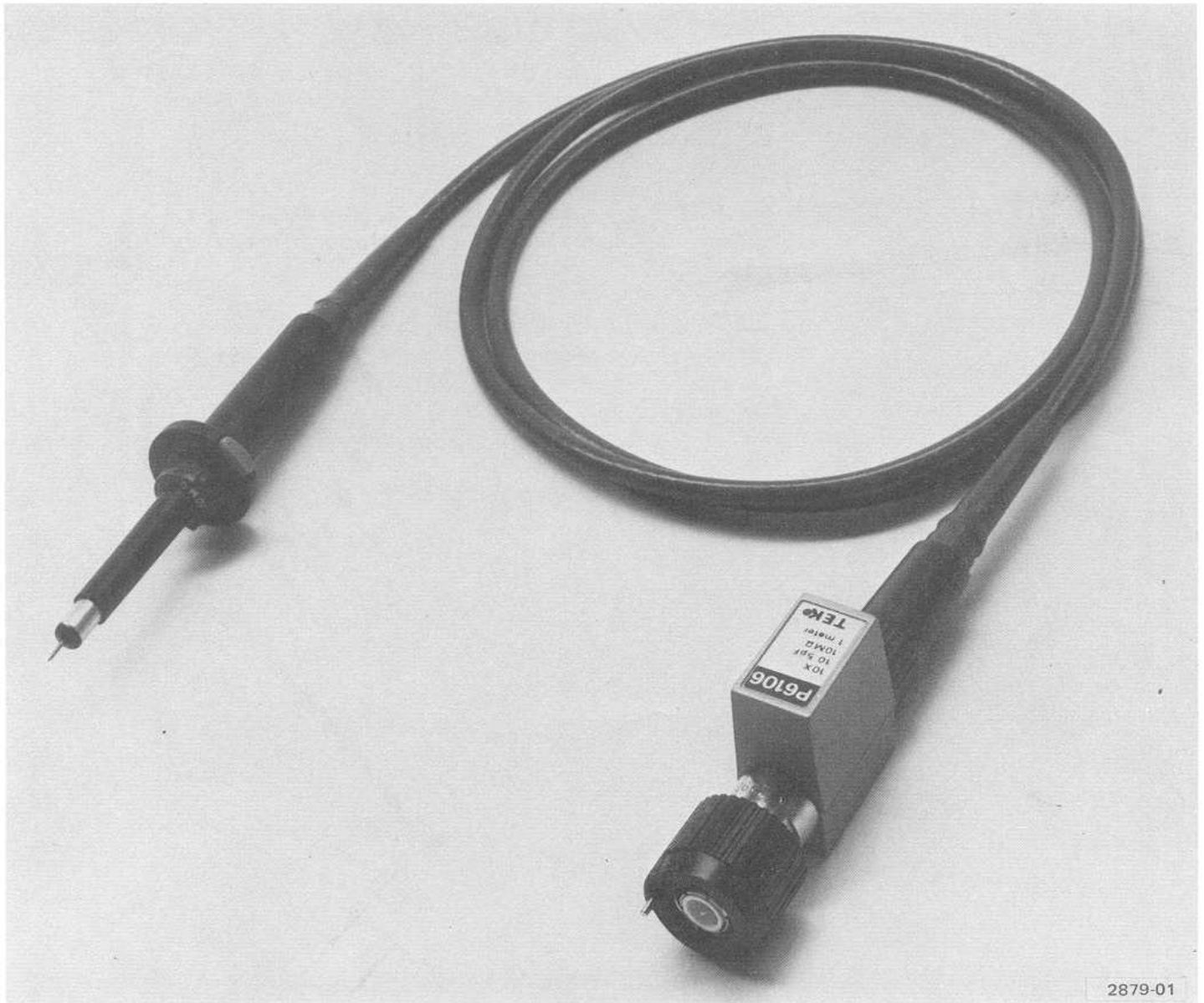

# Instructions

## P6106 Passive Probe

---



2879-01

## WARRANTY

This Tektronix product is warranted against defective materials and workmanship, under normal use, for a period of one year from date of initial shipment. Tektronix will repair or replace, at its option, those products determined to be defective within the warranty period and returned, freight prepaid, to a Tektronix Service Center. There is no implied warranty for fitness of purpose.

Please direct all requests for service or replacement parts to the nearest Tektronix Service Center or Field Office; include the type or part number of the product and its serial number.

Copyright © 1979 by Tektronix, Inc. All rights reserved. Contents of this publication may not be reproduced in any form without the permission of Tektronix, Inc.

Products of Tektronix, Inc. and its subsidiaries are covered by U.S. and foreign patents and/or pending patents.

TEKTRONIX, TEK, SCOPE-MOBILE, TELEQUIPMENT, and  are registered trademarks of Tektronix, Inc.

Printed in U.S.A. Specification and price change privileges are reserved.

# P6106 PASSIVE PROBE

## DESCRIPTION

The P6106 Probe is a miniature, 10X, passive probe for use with dc to 350 MHz oscilloscopes with an input capacitance range of 15-24 pF and an input resistance of 1 M $\Omega$ .

A ground reference push button on the probe head permits the user to obtain a ground reference or to determine a trace in a multitrace display. A coding pin on the bnc output connector activates the volts/div readout encoding of the oscilloscope to include the 10X attenuation of the probe.

### **WARNING**

*To avoid shock, do not disassemble the probe while it is connected to a signal or voltage source. Disassembly is a service operation only. Refer servicing to qualified service personnel.*

The compensating box houses an adjustable network that provides optimum transient response when used with oscilloscopes having bandwidths up to 350 MHz. The probe can be low-frequency compensated by adjusting the variable capacitor through the hole in the compensating box housing. Modular construction of the probe simplifies repairs, as both probe head and compensating box can be unplugged from the cable assembly.

The P6106 Probe is available in three lengths, and is identified by the colored strain relief at each end of the cable: blue, 1 meter (3.3 feet); yellow, 2 meters (6.6 feet); and red, 3 meters (9.9 feet).

# SPECIFICATION

The electrical characteristics listed below apply when the probe is used within the environmental conditions as stated in Table 2 and when the probe is calibrated and used with a calibrated oscilloscope system.

Items listed in the Performance Requirement column are verifiable qualitative or quantitative limits. Items listed in the Supplemental Information column are not verified in the Performance Check or Calibration Procedure in this manual; they are either explanatory notes, performance characteristics for which no absolute limits are specified, or characteristics that are impractical to check in routine maintenance.

**Table 1**  
**ELECTRICAL**

Characteristic	Performance Requirement	Supplemental Information
Attenuation	10X within 3%.	Oscilloscope input, $1\text{ M}\Omega \pm 2\%$ . P6106 series resistor, $9\text{ M}\Omega \pm 0.1\%$ .
Input Resistance		$10\text{ M}\Omega$ within 0.5%. Oscilloscope input, $1\text{ M}\Omega \pm 2\%$ .
Input Capacitance		Probe connected to instrument and properly compensated.
1 Meter (3.3 feet)		Approximately 10.5 pF.
2 Meters (6.6 feet)		Approximately 13.0 pF.
3 Meters (9.9 feet)		Approximately 15.5 pF. See Figs. 1 and 2 for Input Resistance ( $R_p$ ) and Parallel Reactance ( $X_p$ ) versus frequency.
Compensation Range	15 pF to 24 pF.	
Bandwidth (–3 dB)		Oscilloscope bandwidth, at least 255 MHz.
1 Meter	At least 250 MHz.	
2 Meters	At least 250 MHz.	
3 Meters	At least 150 MHz.	All three probes are useable on oscilloscopes with bandwidths up to 350 MHz. When the 1-meter probe is used with oscilloscopes having bandwidths of at least 325 MHz, the system bandwidth will typically be 300 MHz.
Aberrations		Typically +3%, –3%, or 5% peak-to-peak in addition to oscilloscope aberrations, when used with an oscilloscope having a bandwidth of 255 MHz or greater.

Table 1 (cont)

ELECTRICAL

Characteristic	Performance Requirement	Supplemental Information
Maximum Input Voltage	500 V (dc + peak ac) to 1.7 MHz, derated to 70 V at 100 MHz. This specification applies when the oscilloscope is set for dc coupling. See Fig. 3 for Voltage vs Frequency derating.	Impractical to check in routine maintenance.
Ground Reference Push Button	Oscilloscope input is referenced to ground by depressing this button.	Probe tip is isolated from ground by 9 MΩ.

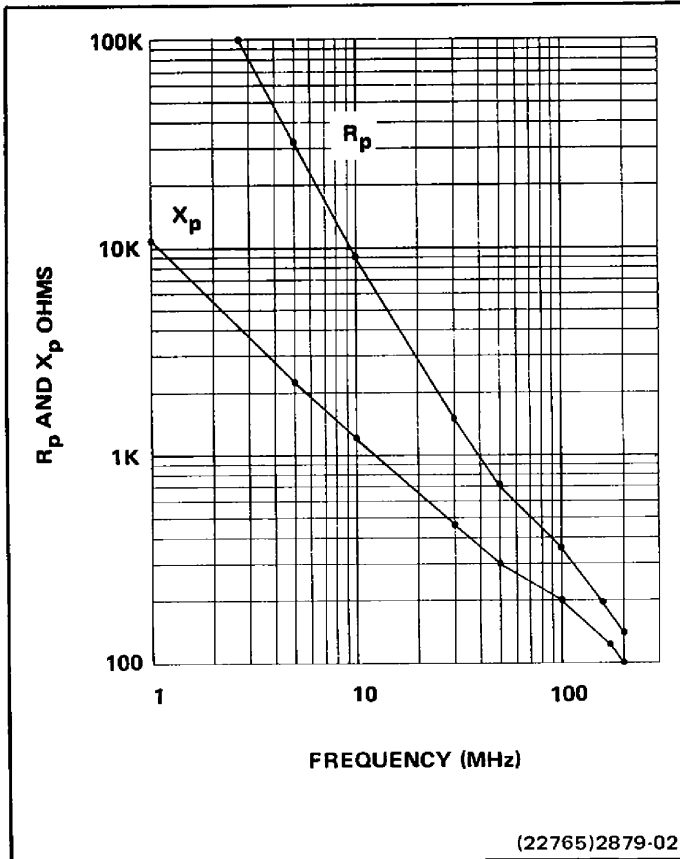

Fig. 1. P6106 Probe (1-meter cable), typical Xp, Rp versus frequency curves.

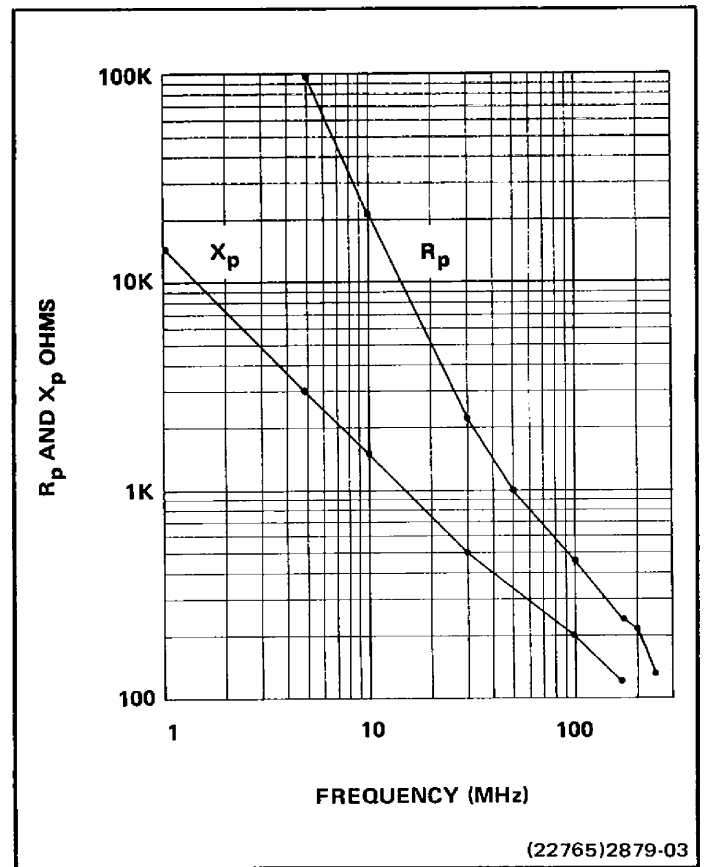

Fig. 2. P6106 Probe (2- and 3-meter cable), typical Xp, Rp versus frequency curves.

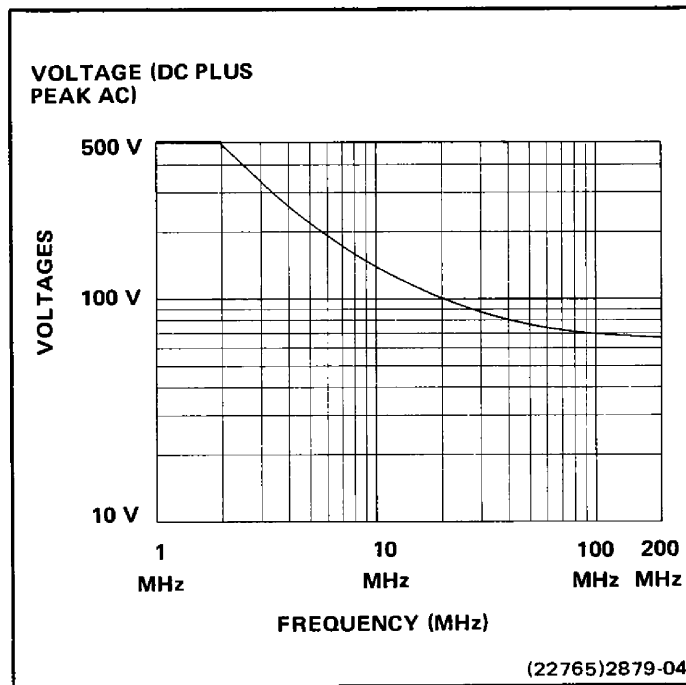

Fig. 3. P6106 Probe, typical voltage derating with frequency curve.

Table 2  
ENVIRONMENTAL

Characteristic	Information
Temperature Range Operating	-15°C to +75°C (+5°F to +167°F).
Altitude Operating	To 4,500 meters (15,000 feet).
Transportation	Qualifies under National Safe Transit Test Procedure 1A, 48-inch drop.

Table 3  
PHYSICAL

Characteristic	Information
Net Weight (Includes Accessories)	
1 Meter (3.3 feet) Probe	111 grams (3.9 ounces).
2 Meters (6.6 feet) Probe	136 grams (4.8 ounces).
3 Meters (9.9 feet) Probe	159 grams (5.6 ounces).

# OPERATING CONSIDERATIONS

## Probe Grounding

A passive probe is a capacitive divider for high-frequency signal components. Inductance introduced by a long signal lead or ground lead will form a series-resonant circuit that will ring, if driven by a signal containing significant frequency components, at or above circuit resonance. These oscillations can appear on the oscilloscope display and distort the true waveform. Ground leads and probe tip connections should be kept as short as possible to maintain the best fidelity.

## PROBE ACCESSORIES

A variety of items are supplied as standard accessories with the P6106 (see Accessories located in the parts list at the rear of this manual). These accessories are supplied to aid in connecting the probe into circuitry under test and to protect the probe against damage.

### Ground Leads

Two ground leads are supplied, one of 3.5-inch length and the other is a 5-inch length. The shorter lead should be used whenever possible to minimize the chance of ringing. The spring clip, at the end of the ground lead, clips over the metal sleeve just inside the plastic part in front of the flange on the probe head. The insulated miniature alligator clip screws onto the other end of the ground lead.

### Insulating Sleeve

The small tubular insulating sleeve supplied with the accessories should be placed over the metal sleeve of the probe tip when using the ground lead. This is intended to avoid inadvertently grounding circuitry under test. The sleeve should be left off when using either the retractable hook tip or the integrated circuit (IC) test tip.

## Retractable Hook Tip

The retractable hook tip provides a positive connection to a test point or component lead. The spring in the tip allows the user to leave the probe connected to the test point while making adjustments or performing functions elsewhere in the device under test. The tip is attached to the probe by sliding it on over the probe-head tip. To expose the tip end for connection, hold the probe head behind the head flange and pull the tip flange back toward the head flange. The spring in the tip pulls the connection snug when the flange is released.

## Probe Tip Adapter (IC Test)

This adapter is especially useful when probing the leads on a flat-pack type integrated circuit. The configuration prevents the probe tip from shorting adjacent leads together and insulates the ground surface of the metal sleeve at the probe tip.

## Probe Holder

The probe holder supplied has adhesive on the rear side for attachment to the oscilloscope cabinet side. Peel off the protective covering and attach to the cabinet side, preferably nearest the vertical inputs. The holder has receptacles for two probes. When the probe is not in use, place the tapered portion behind the probe head into the holder.

## Readout Connector

The bnc connector at the end of the probe cable is equipped with a spring-loaded contact finger that actuates the 10X readout multiplier resistor that is built into the connector. This resistor automatically advances the volts/division reading by 10X in oscilloscopes equipped with this feature so that the correct deflection factor at the probe tip is indicated.

## Ground Reference Push Button

A small, gray push-button switch is located on the outer ring of the flange on the probe head. Pressing this button provides a dc ground reference for the oscilloscope display. The probe tip is isolated from ground by 9 M $\Omega$ , which allows ground reference to be established without disconnecting the probe tip from circuitry under test.

# PROBE COMPENSATION AND PERFORMANCE CHECK

## WARNING

To avoid electrical shock, do not disassemble the probe when connected to a signal or voltage source.

Due to slight variations in the oscilloscope input capacitance, it is usually necessary to compensate the probe whenever it is transferred from one instrument to another, or from one channel to another for dual (multi-trace) units.

## TEST EQUIPMENT REQUIRED

The test equipment listed here was used in preparing this procedure. The measurement capabilities described (under Minimum Specification) are the minimum required to properly check and compensate the probe to the Performance Requirement listed under Specification. Each piece of test equipment is assumed to be operating within its stated specifications. If alternative equipment is used, it must meet or exceed these requirements.

Table 4

TEST EQUIPMENT REQUIRED

Description	Minimum Specification	Suggested Instrument
Oscilloscope System	Bandwidth, 255 MHz <sup>a</sup> or greater; deflection factor, 10 mV/div (0.1 V/div with probe); sweep rate, 1 ms/div to 10 ns/div.	TEKTRONIX 475A or 485.
Pulse or Square-Wave Generator	Pulse rise time, 1 ns or less; amplitude, 0.5 V or greater into 50 Ω; repetition rate, 100 kHz.  Square-wave frequency, 1 kHz; amplitude, 0.5 V and 50 mV into 1 MΩ; accuracy, ±0.25%.	TEKTRONIX PG 506 Calibration Generator <sup>b</sup> (supplies both fast-rise and standard-amplitude signals).  If available, a TEKTRONIX Type 106 Square-Wave Generator may be used for compensation adjustments. However, an amplitude calibrator is necessary if attenuation accuracy is to be checked. <sup>c</sup>
Leveled Sine-Wave Generator	Amplitude, adjustable from 0 V to at least 1 V peak-to-peak into 50 Ω; frequency, variable from 1 MHz to at least 250 MHz plus fixed 50 kHz reference.	TEKTRONIX SG 503 Leveled Sine Wave Generator. <sup>b</sup>
Cable with bnc Connectors	Coaxial, precision 50 Ω, 36-inch length.	Tektronix Part Number 012-0482-00.
Attenuator with bnc Connectors	Attenuation, 10X; impedance, 50 Ω; connectors, bnc.	Tektronix Part Number 011-0059-02.
Termination, Thru-Line with bnc Connectors	Impedance, 50 Ω; connectors, bnc.	Tektronix Part Number 011-0049-01.

<sup>a</sup> 475A bandwidth is typically in excess of 255 MHz as shipped from the factory.

<sup>b</sup> Requires TM 500-Series Power Module.

<sup>c</sup> Type 106 is no longer in production. If used in this procedure, appropriate cables, attenuator, and adapter/termination is required.

Table 4 (cont)

Description	Minimum Specification	Suggested Instrument
Termination Adapter, Miniature Probe Tip-to-GR	Must adapt P6106 probe tip to GR connector, with 50- $\Omega$ termination physically located directly at probe tip.	Tektronix Part Number 017-0088-00.
Adapter, GR-to-bnc Female	Must adapt GR termination adapter to bnc coaxial cable connector.	Tektronix Part Number 017-0063-00.

## PRELIMINARY SETUP

### NOTE

*In the following procedure, generic terms will be used to indicate test equipment in most cases. This will also apply to names of controls and signals.*

1. Set the test oscilloscope volts/div to 10 mV, and the time/div to 1 ms. Set the input coupling to dc, and the bandwidth switch to full bandwidth.

2. Set the calibration generator for a standard-amplitude output of 1.0 V (0.5 V into 50  $\Omega$  load). The signal output should be a square wave at approximately 1 kHz.

3. Turn the test oscilloscope and associated test equipment power on and allow enough warmup time for the equipment to stabilize (typically 20 minutes).

4. Install the P6106 Probe onto the test oscilloscope vertical input connector. Check that the test oscilloscope volts/div has automatically switched to indicate 0.1 V/div.

## PROCEDURE

### 1. Adjust Low-Frequency Compensation (C3)

a. Attach the probe tip-to-GR termination adapter to the P6106 Probe tip, the GR-to-bnc female adapter to the termination adapter, and then through the 50- $\Omega$  coaxial cable to the calibration generator standard-amplitude output connector.

b. Set the oscilloscope triggering controls for a stable, triggered display. The display should be approximately 10 cycles of square wave, with an amplitude of 5 divisions. Center the display on the screen.

c. ADJUST—the probe low-frequency compensation (C3, see Fig. 5). Use a low-reactance adjusting tool (e.g., nylon) when making any compensation adjustments in the P6106. Figure 4 shows the approximate range of adjustment, and the correct setting.

### 2. Adjust High-Frequency Compensation (C2, R2, R3, R4)

a. Disconnect the P6106 Probe from the test oscilloscope and the calibration generator.

b. Connect the positive-going fast-rise output of the calibration generator through the 50- $\Omega$  cable, 50- $\Omega$  10X attenuator, and 50- $\Omega$  thru-line termination to the test oscilloscope vertical input connector.

c. Set the calibration generator for a fast-rise output with a period (repetition rate) of 10  $\mu$ s (100 kHz).

d. Set the test oscilloscope time/div to 0.02  $\mu$ s, and the volts/div switch to 10 mV.

e. Set the calibration generator amplitude control for a 5-division display on the test oscilloscope, and set the oscilloscope triggering controls for a stable, triggered display. Center the display on the screen.

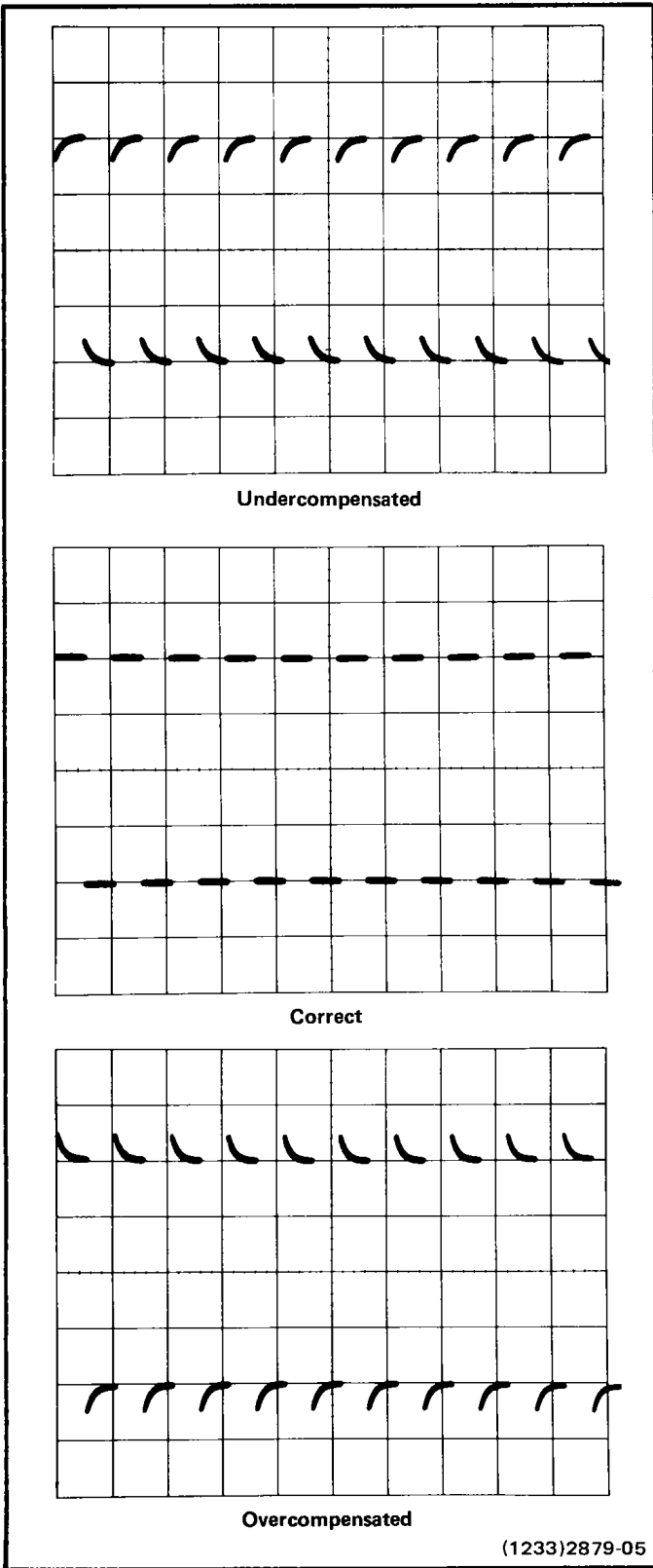

Fig. 4. Probe low-frequency compensation (C3).

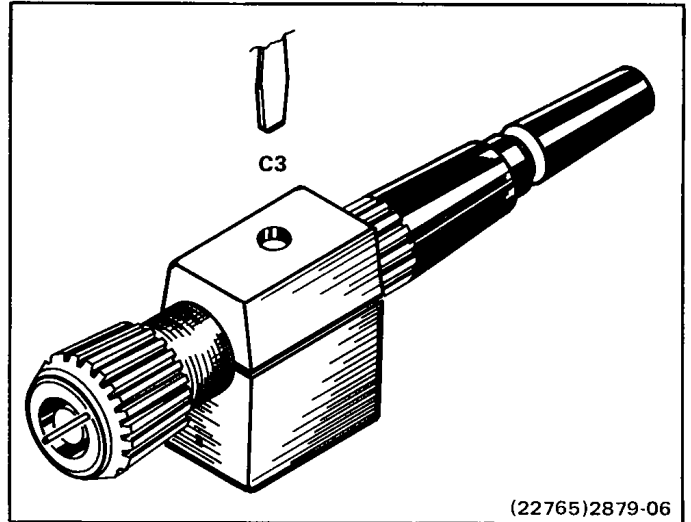

Fig. 5. Low-frequency adjustment location.

f. Note the pulse shape and aberrations. (For the 475A, typical maximum aberrations are +4%, -4%, and 4% p-p.) Figure 6 shows the pulse response of a typical 475A.

g. Move the coaxial-cable connection from the calibration-generator fast-rise output connector to the output connector on the leveled sine-wave generator. Set the sine-wave generator frequency range switch to Ref  $\approx .05$  (50 kHz), and the output amplitude to 0.6 V.

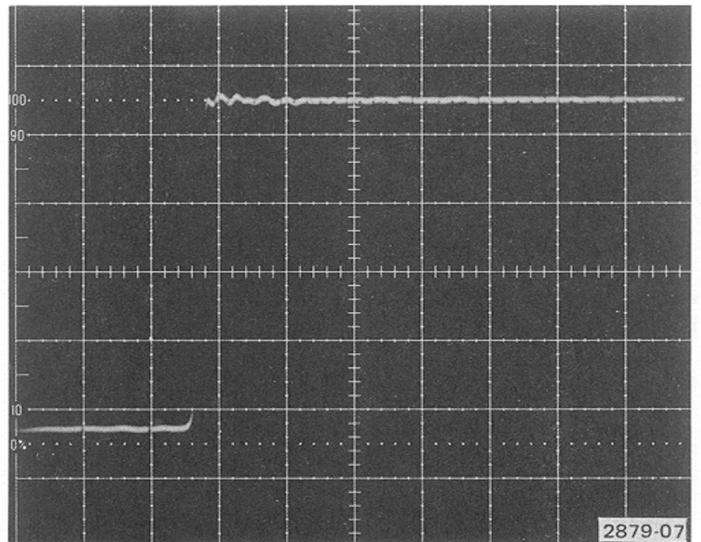

Fig. 6. Pulse response of a typical TEKTRONIX 475A Oscilloscope. Pulse source is the positive-going Fast Rise Output of a PG 506 Calibration Generator. The oscilloscope sweep rate is 10 ns/div, and the deflection factor is 10 mV/div.

h. Set the test oscilloscope time/div to 1 ms, the volts/div to 10 mV, and check that the bandwidth switch is set to full bandwidth.

i. Carefully set the sine-wave generator output amplitude for a 6-division display on the test oscilloscope screen. Center the display on the screen. See Fig. 7 (A).

j. Set the sine-wave generator frequency-range switch to the highest range (100-250 MHz), and slowly increase the setting of the variable frequency control until the display amplitude decreases to 4.2 divisions ( $-3$  dB). See Fig. 7 (B).

#### NOTE

*The variable frequency control may run out of range before the display amplitude drops to 4.2 divisions. This assures that the test oscilloscope is exceeding the minimum required bandwidth. Note the reading of the sine-wave generator frequency readout. This must be at least 255 MHz.*

k. If aberrations from part f are excessive, or if bandwidth from part j is insufficient, refer to the test oscilloscope calibration procedure and calibrate the instrument, as necessary, before proceeding.

l. Disconnect the cable, attenuator, and termination from the sine-wave generator output and the test oscilloscope input. Install the P6106 Probe on the test oscilloscope vertical input connector. (The probe compensation box cover should be removed. See instructions under Maintenance.)

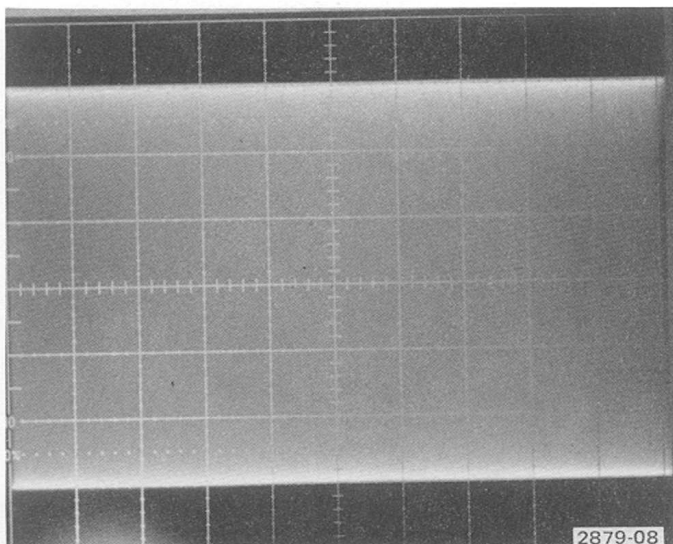

Fig. 7. Test oscilloscope displays when checking bandwidth. (A) 6-division display at reference frequency (50 kHz).

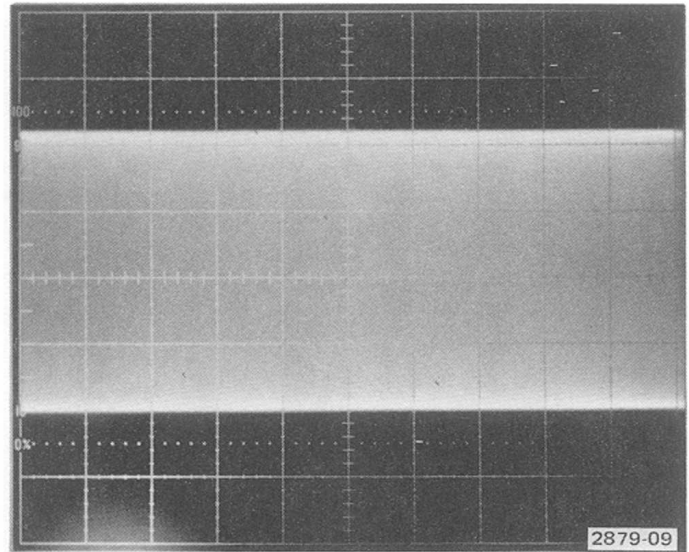

Fig. 7(B). 4.2-division display at upper bandwidth  $-3$  dB point (250 MHz).

m. Connect the probe tip to the positive-going fast-rise output on the calibration generator, using the probe tip-to-GR termination adapter, the GR-to-bnc female adapter, and the  $50\text{-}\Omega$  coaxial cable. See Fig. 8.

n. Set the generator for a fast-rise output with a period (repetition rate) of  $10\ \mu\text{s}$  (100 kHz).

o. Set the test oscilloscope time/div to  $0.02\ \mu\text{s}$ , and the volts/div to 0.1 V (includes 10X attenuation of P6106).

p. Set the generator amplitude control for a 5-division display on the test oscilloscope, and set the oscilloscope triggering controls for a stable, triggered display. Center the display on the screen.

q. CHECK—high-frequency aberrations. Typically, aberrations will not exceed  $+3\%$ ,  $-3\%$ , or  $5\%$  peak-to-peak (this is in addition to test oscilloscope aberrations, as noted in part f). Figures 9 and 10 show typical pulse response of the 1-meter and 2-meter probes, respectively, when adjusted to make 250 MHz bandwidth on the 475A.

#### NOTE

*The P6106 Probe is factory-compensated to meet the bandwidth specification, using a 475A with proper bandwidth. For best overall performance, the P6106 should be adjusted on the oscilloscope with which it is to be used.*

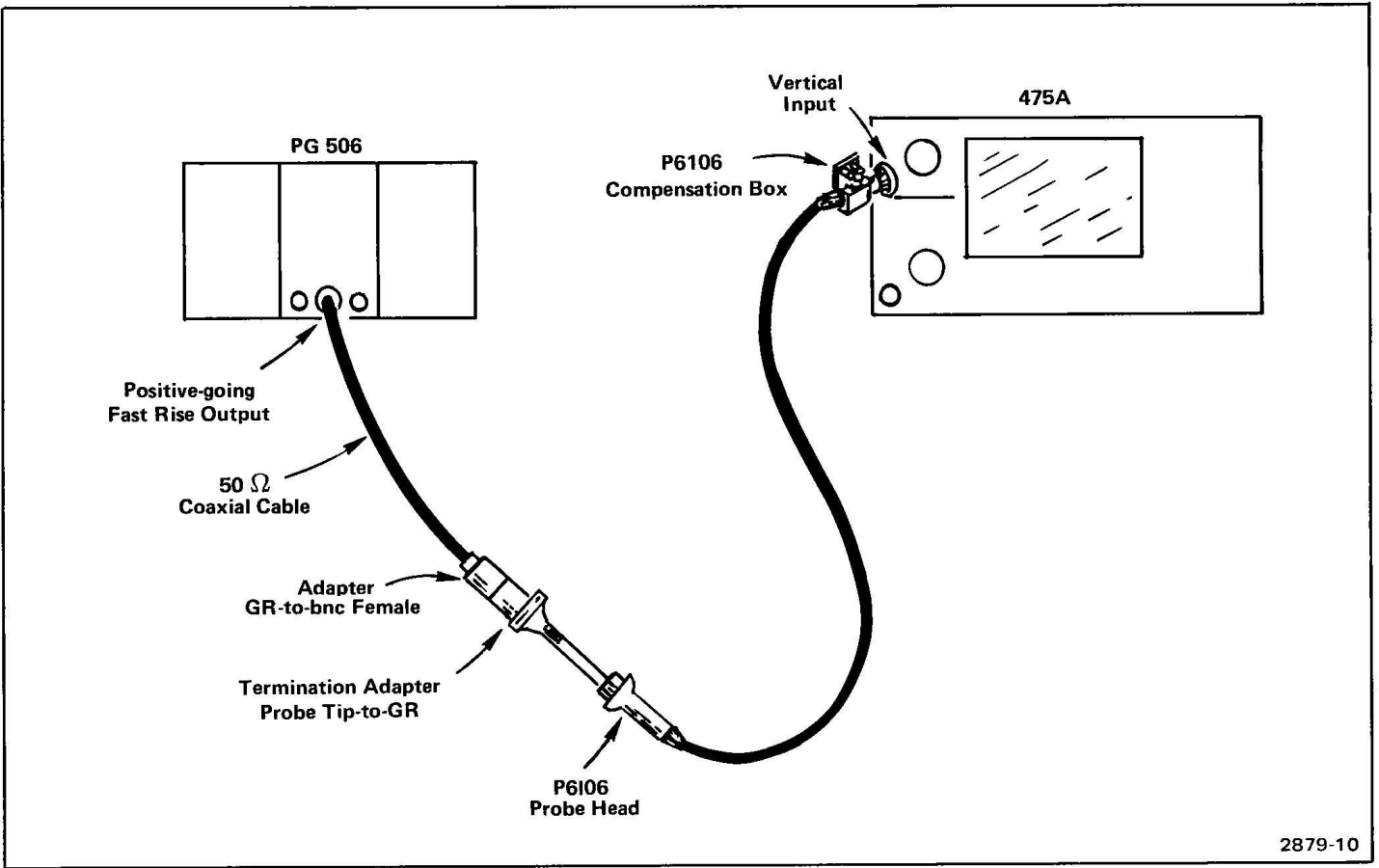

2879-10

Fig. 8. Equipment hookup for checking high-frequency compensation.

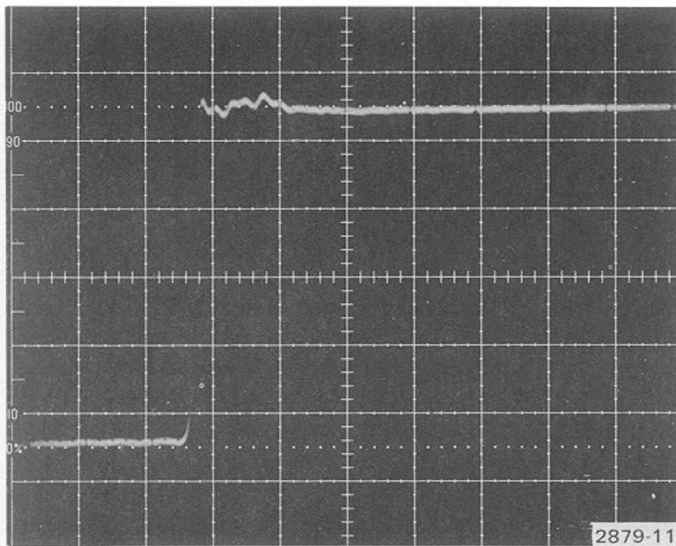

2879-11

Fig. 9. Typical pulse response of the 1-meter cable length P6106 when adjusted for 250-MHz bandwidth with the 475A.

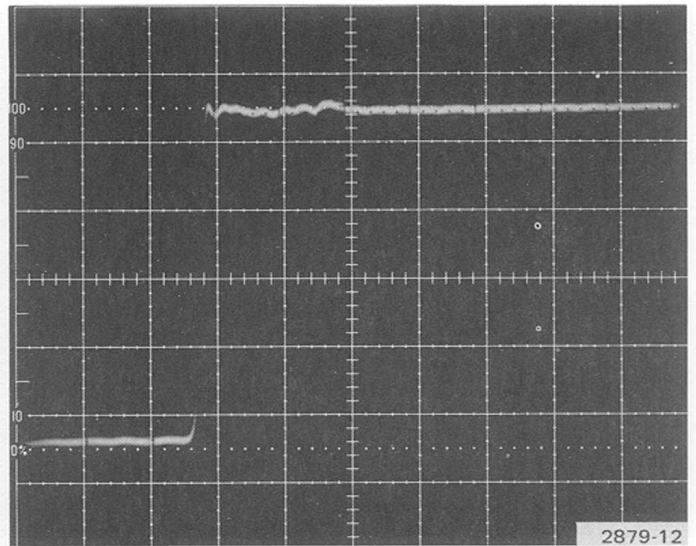

2879-12

Fig. 10. Typical pulse response of the 2-meter cable length P6106 when adjusted for 250-MHz bandwidth with the 475A.

If aberrations are excessive, proceed as follows:

r. ADJUST—R2 and R4 for best overall flat response. See Fig. 11 for details of area on waveform affected relative to each adjustment. Figures 12 and 13 show locations of adjustments in the 1-meter, 2-meter, and 3-meter length probes, respectively.

s. ADJUST—R3 and C2 for best corner response (without ringing). See Figs. 11, 12, and 13.

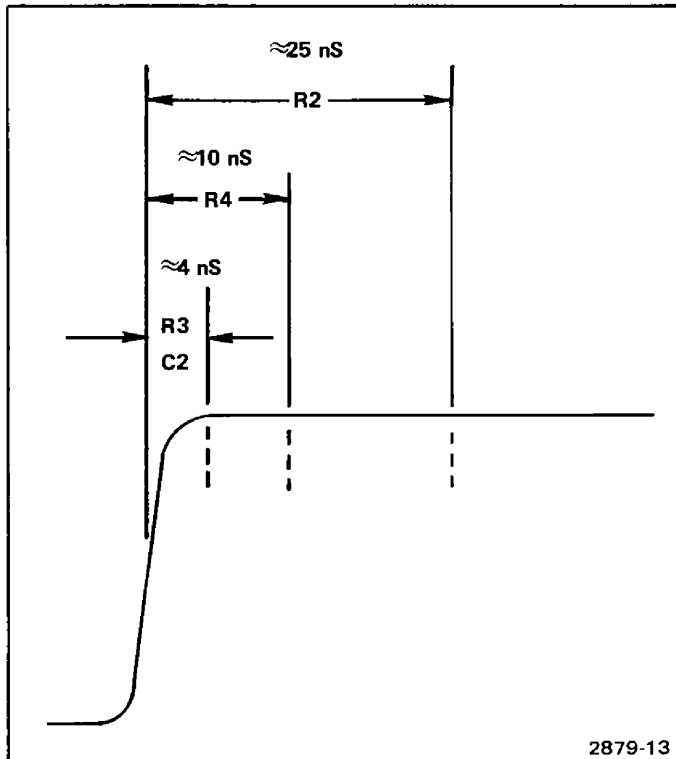

Fig. 11. High-frequency adjustments, relative to areas of the waveform that are affected by each adjustment.

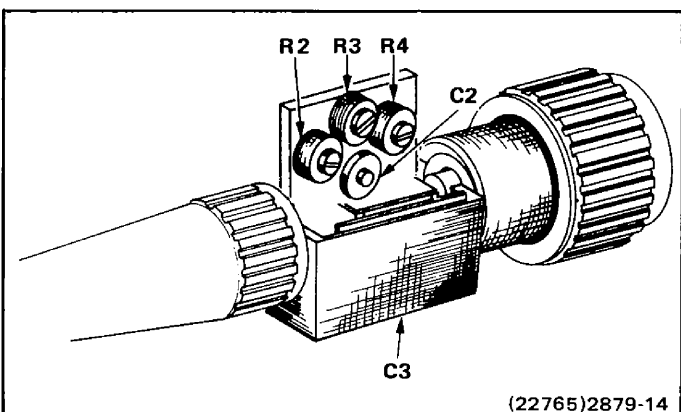

Fig. 12. High-frequency adjustment locations in the 1-meter cable length P6106.

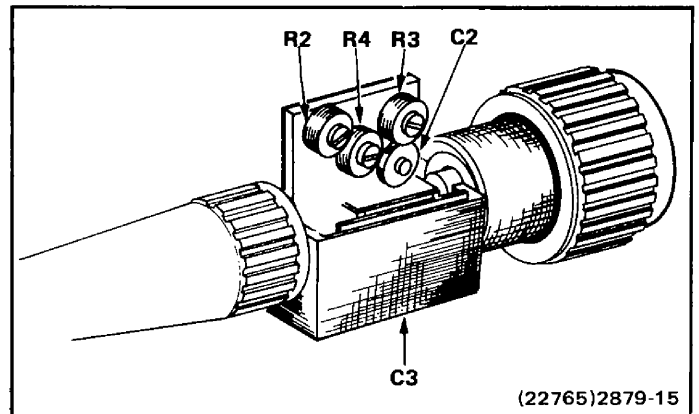

Fig. 13. High-frequency adjustment locations in the 2- and 3-meter cable length P6106.

### 3. Check Bandwidth

a. Move the coaxial cable connection from the calibration-generator output connector to the output connector on the leveled sine-wave generator. Set the sine-wave generator frequency-range switch to Ref  $\approx .05$  (50 kHz), and the output amplitude to 0.6 V.

b. Set the test oscilloscope time/div to 1 ms, the volts/div switch to 0.1 V (includes 10X attenuation of P6106), and check that the bandwidth switch is set to full bandwidth.

c. Carefully set the sine-wave generator output amplitude for a 6-division display on the test-oscilloscope screen. Center the display on the screen.

d. Set the generator frequency-range switch to the highest range (100-250 MHz), and slowly increase the setting of the variable frequency control until the display amplitude decreases to 4.2 divisions ( $-3$  dB).

e. CHECK—bandwidth of the P6106/475A system as indicated by the sine-wave generator frequency readout. If the reading is less than 250 MHz, repeat Step 2, parts I through s. (A small overshoot on the leading edge of the pulse after adjustment may be necessary to make the bandwidth specification. However, the overshoot should not exceed the typical aberrations as described in Step 2, part q. Remember that any aberration noted is in addition to that of the test oscilloscope. For example, if the test oscilloscope alone has 4% of overshoot at the leading corner, the probe is within normal limits if as much as 7% of overshoot exists on the same part of the pulse as the overshoot noted for the oscilloscope alone.)

#### **4. Check Probe Attenuation Accuracy**

a. Connect the calibration generator standard-amplitude output to the test oscilloscope vertical input via the 50- $\Omega$  coaxial cable, the 10X 50- $\Omega$  attenuator (with bnc connectors), and the 50- $\Omega$  bnc thru-line termination. Set the calibration generator for a standard-amplitude output of 1.0 V (0.5 V into 50  $\Omega$  load). With the 10X attenuator in the signal line, the amplitude at the oscilloscope input is 50 mV. The frequency should be approximately 1 kHz.

b. Set the test oscilloscope volts/div to 10 mV, the time/div to 1 ms, and set the triggering controls for a stable, triggered display.

c. Check the amplitude of the display. This should be 5 divisions. If not, the Variable Amplitude control can be set for an exact 5-division display, and the percent of error (high or low) will be indicated on the PG 506 Deflection Error readout. Leave the Variable Amplitude control at this same setting for the following sub-steps.

If an amplitude calibrator other than the PG 506 is used in this step, use the same procedure except note the error in terms of plus or minus difference from 5 divisions. The probe attenuation error (part f) is then measured from this reference level.

d. Disconnect the coaxial cable, attenuator, and termination at the test oscilloscope input. Remove the termination and attenuator from the end of the cable, leaving the other end still connected to the calibration generator output.

e. Attach the P6106 Probe to the test oscilloscope vertical input, and connect the probe tip, via the probe tip-to-GR termination adapter and the GR-to-bnc female adapter to the open end of the coaxial cable. Leave all controls set as established in parts a and b of this step.

f. CHECK—probe attenuation accuracy. The display should be 5 divisions,  $\pm 3\%$  ( $\pm 0.15$  division).

g. Replace the probe compensation box cover, and recheck the pulse response as described in Step 2, parts m through q.

#### **5. Check Ground Reference Push Button**

a. Leave all equipment connected and set as described in Step 4, part g. Set the test oscilloscope triggering to Auto mode.

b. Press in the Ground Reference push button on the P6106 Probe head.

c. CHECK—that the display changes to a single horizontal line on the screen. This line indicates the dc ground reference level.

This completes the Probe Compensation and Performance Check procedure. Disconnect all test equipment.

# MAINTENANCE

## WARNING

*To avoid electrical shock, do not disassemble the probe when connected to a voltage source. Only qualified service personnel should use the following service instructions. Unless you are qualified to do so, perform no servicing except that contained in the preceding operating instructions.*

The P6106 is designed to withstand normal usage, but may be damaged if treated carelessly. Avoid kinking or straining the cable, or subjecting the probe to extreme environmental conditions or excessive voltages (see Specification). When not in use, the probe should be stored in a drawer, or supported by the plastic holder supplied with the probe.

If the probe is damaged or fails, replacement modules are available through your local Tektronix Field Office or representative. The list at the rear of this manual provides the Tektronix part numbers and descriptions for replaceable parts.

Modular construction has been incorporated in the design of the P6106 to simplify repairs. The probe head and the compensating box assembly can be unplugged from the cable assembly, and each of these assemblies is available as a wired unit for replacement. Individual components within the probe head and the compensating box are not considered replaceable parts. However, the bnc connector with 10X readout is available for replacement.

## Replacing a Probe Assembly

When replacing probe assemblies, make sure to use the proper probe head and compensation box for the length of cable being used. Check that colors on the probe-head ground collar and the compensating box retainer nut match the cable strain reliefs. Color coding of the three lengths is as follows: blue, 1 meter; yellow, 2 meters; red, 3 meters.

## Removing the Compensation Box Cover

Removing the cover from the probe compensation box is simple and requires no tools. First, pull the cable end straight out from the box housing. Then, unscrew the compensation box cover retainer several turns ( $\approx 3/16$  inch). Lift the end of the cover (nearest the cable end) straight up and pull back, freeing the cover. Re-tighten the retainer and plug the cable end back into the housing, making sure that the connection is pressed in firmly. To replace the cover, reverse the procedure.

## Replacing the Probe Tip

If the probe tip becomes damaged, it can be replaced. A special probe tip remover tool is supplied with the P6106 standard accessories. See Fig. 14 for probe tip removal and replacement instructions.

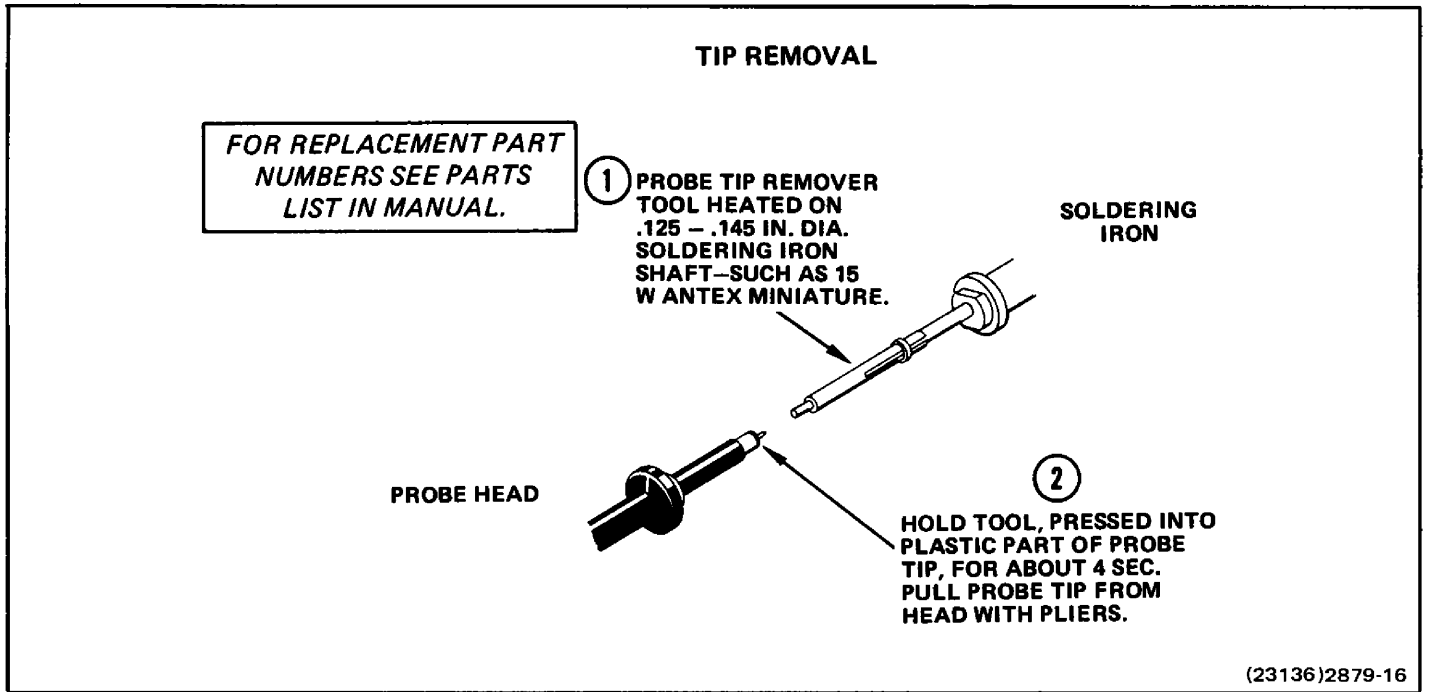

Fig. 14. Probe tip removal and replacement.

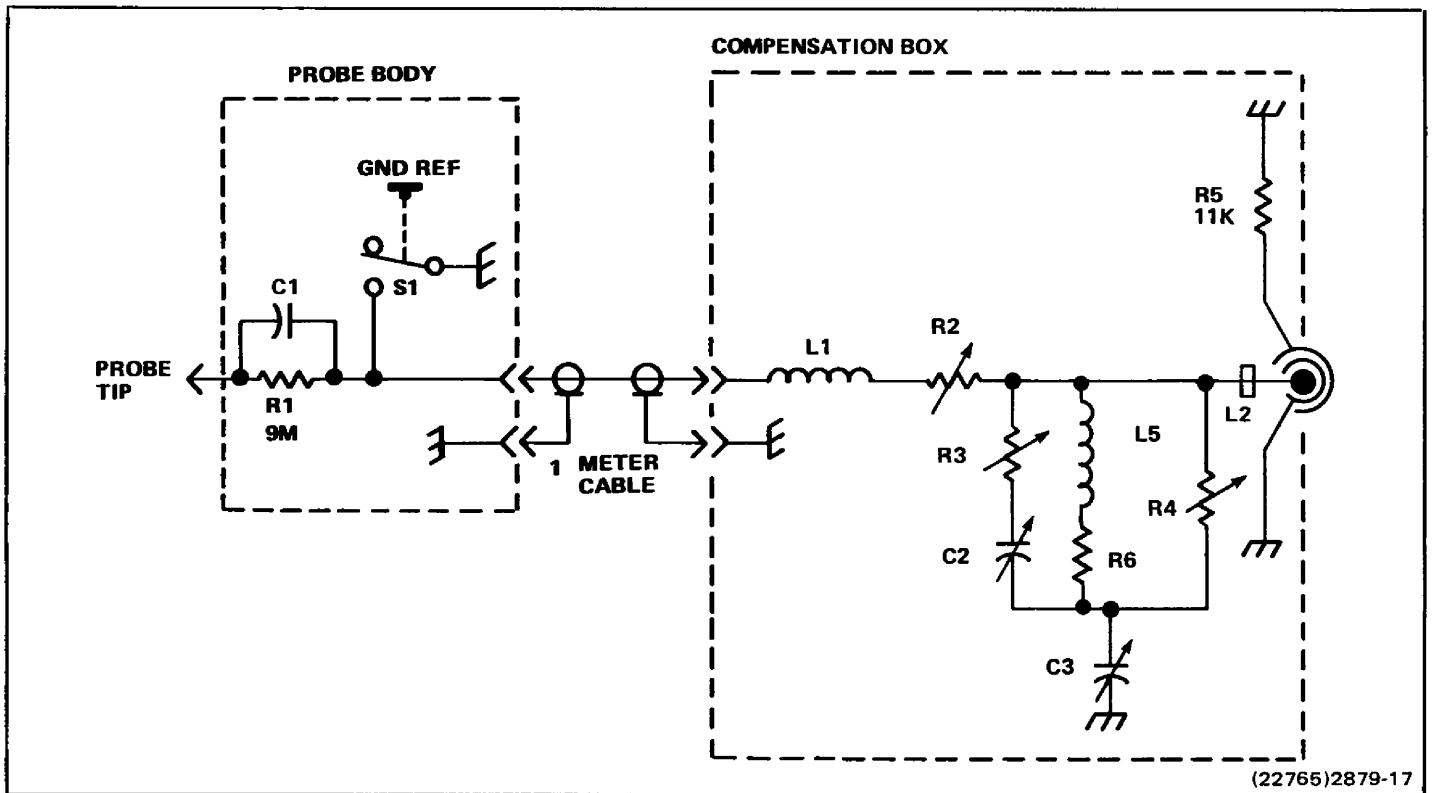

Fig. 15. Schematic diagram for the 1-meter P6106.

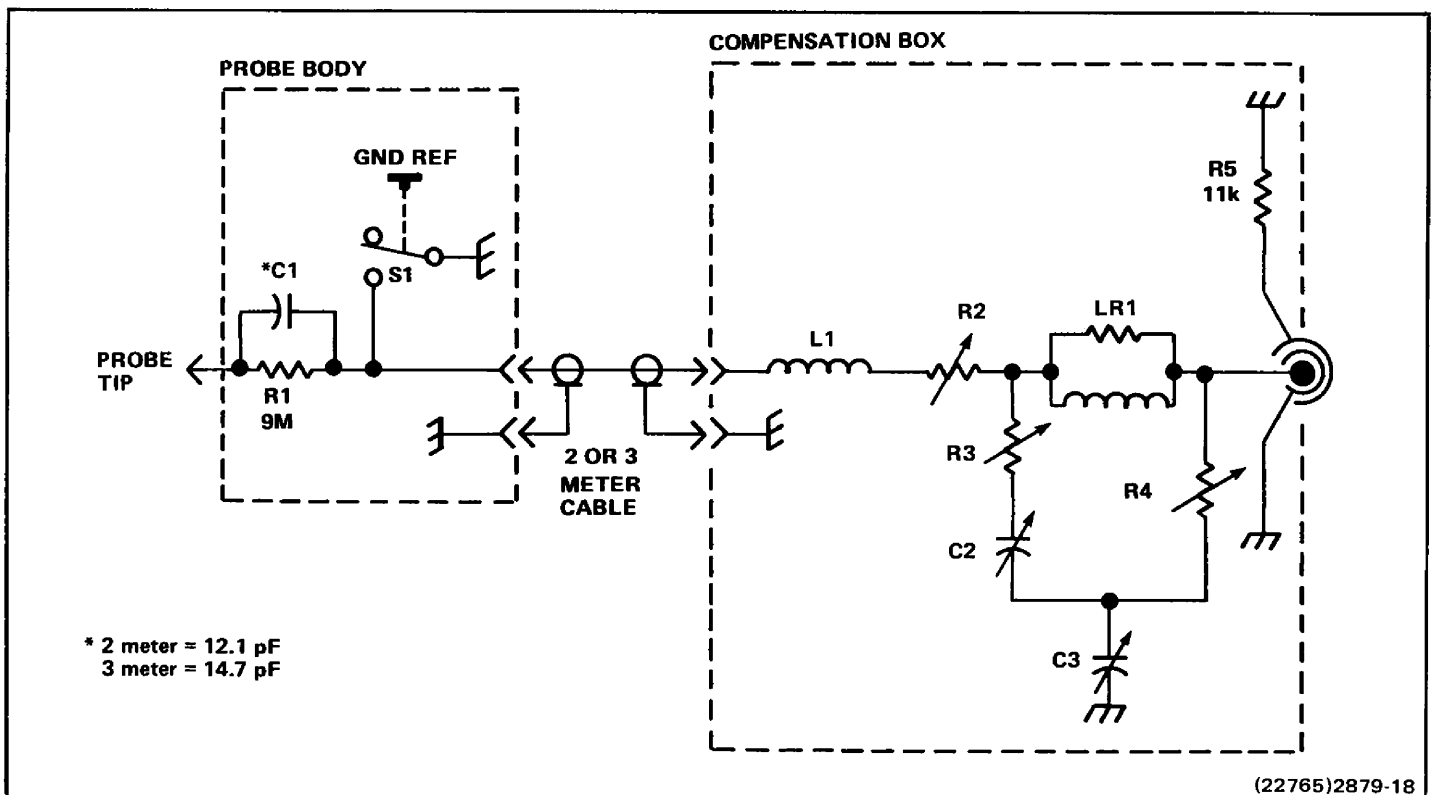

Fig. 16. Schematic diagram for the 2- and 3-meter P6106.

# REPLACEABLE PARTS LIST

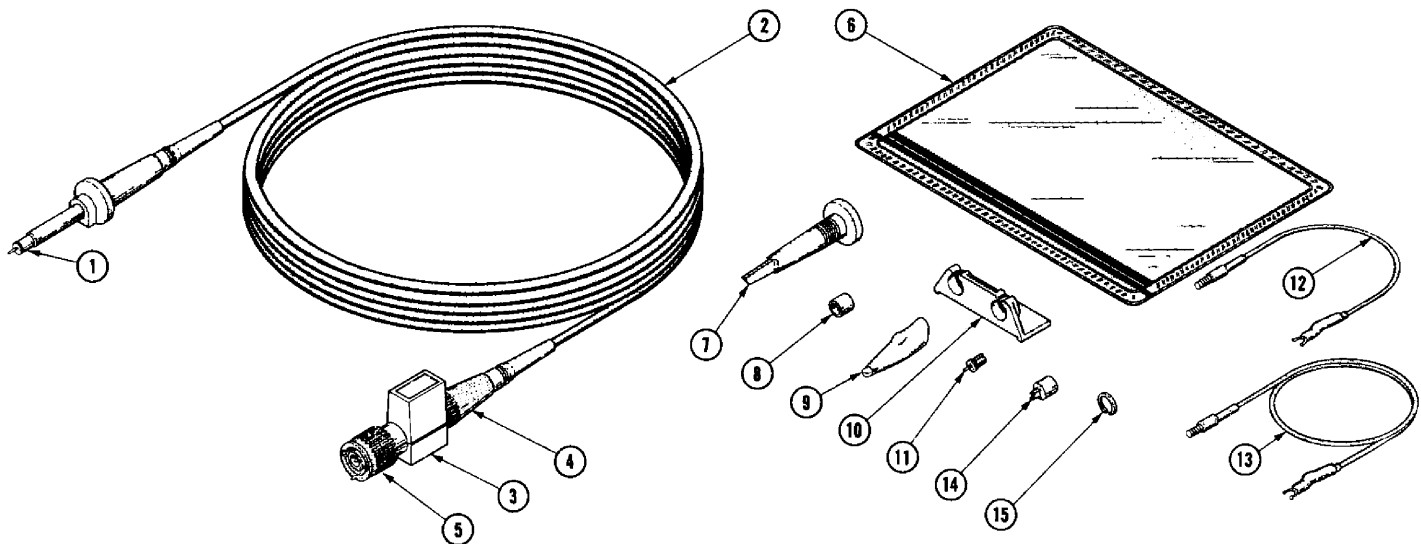

Fig. & Index No.	Tektronix Part No.	Serial/Model No. Eff	Dscont	Qty	1	2	3	4	5	Name & Description	Mfr Code	Mfr Part Number
------------------	--------------------	----------------------	--------	-----	---	---	---	---	---	--------------------	----------	-----------------

1 METER PROBE

	010-6106-01			1						LEAD,TEST:1 METER,BLUE,W/ACCESSORIES	80009	010-6106-01
	010-6106-00			1						. LEAD,TEST:1 METER,BLUE	80009	010-6106-00
-1	206-0191-01			1						. . . TIP,PROBE:SET OF 10	80009	206-0191-01
-2	175-1661-00			1						. . . CABLE,SP,ELEC:39 OHM COAX,40.72 LONG	80009	175-1661-00
-3	206-0237-00			1						. . . COMP BOX:1 METER,BLUE	80009	206-0237-00
-4	343-0570-00			1						. . . RETAINER,COVER:COMP BOX,1 METER,BLUE	80009	343-0570-00
-5	131-1799-01			1						. . . CONN,RCPT,ELEC:BNC,FEMALE W/READOUT 10X	80009	131-1799-01

2 METER PROBE

	010-6106-03			1						LEAD,TEST:2 METER,YELLOW,W/ACCESS	80009	010-6106-03
	010-6106-02			1						. LEAD,TEST:2 METER,YELLOW	80009	010-6106-02
-1	206-0191-01			1						. . . TIP,PROBE:SET OF 10	80009	206-0191-01
-2	175-1661-01			1						. . . CABLE,SP,ELEC:39 OHM COAX,79.75 LONG	80009	175-1661-01
-3	206-0238-00			1						. . . COMP BOX:2 METER,YELLOW	80009	206-0238-00
-4	343-0570-01			1						. . . RETAINER,COVER:COMP BOX,2 METER,YELLOW	80009	343-0570-01
-5	131-1799-01			1						. . . CONN,RCPT,ELEC:BNC,FEMALE W/READOUT 10X	80009	131-1799-01

3 METER PROBE

	010-6106-05			1						LEAD,TEST:3 METER,RED,W/ACCESSORIES	80009	010-6106-05
	010-6106-04			1						. LEAD,TEST:3 METER,RED	80009	010-6106-04
-1	206-0191-01			1						. . . TIP,PROBE:SET OF 10	80009	206-0191-01
-2	175-1661-02			1						. . . CABLE,SP,ELEC:39 OHM COAX,119.12 LONG	80009	175-1661-02
-3	206-0239-00			1						. . . COMP BOX:3 METER,RED	80009	206-0239-00
-4	343-0570-02			1						. . . RETAINER,COVER:COMP BOX,3 METER,RED	80009	343-0570-02
-5	131-1799-01			1						. . . CONN,RCPT,ELEC:BNC,FEMALE W/READOUT 10X	80009	131-1799-01

Fig. & Index No.	Tektronix Part No.	Serial/Model No. Eff	Dscont	Qty	1	2	3	4	5	Name & Description	Mfr Code	Mfr Part Number
ACCESSORIES												
-6	016-0521-00			1						POUCH, ACCESSORY:	05006	OBD
-7	013-0107-03			1						TIP, TEST PROD: RET HOOK ASSY	80009	013-0107-03
-8	166-0404-01			1						INS SLV, ELEC: FOR 0.188 DIA PROBE BSHG	80009	166-0404-01
-9	344-0046-00			2						CLIP, ELECTRICAL: ALLIGATOR TYPE, W/COVER	80009	344-0046-00
-10	352-0351-00			1						HOLDER, PROBE: BLACK	80009	352-0351-00
-11	206-0191-01			1						TIP, PROBE: SET OF 10	80009	206-0191-01
-12	175-0263-01			1						LEAD, ELECTRICAL: PROBE GND, 3 INCHES LONG	80009	175-0263-01
-13	175-0124-01			1						LEAD, ELECTRICAL: PROBE GND, 5 INCHES LONG	80009	175-0124-01
-14	015-0201-01			1						TIP, PROBE: IC TEST, PACK OF 10	80009	015-0201-01
	015-0201-02			-						TIP, PROBE: IC TEST, PACK OF 100	80009	015-0201-02
-15	334-2794-00			2						BAND, MARKER: 0.371 DIA, BLACK, PLASTIC	80009	334-2794-00
	334-2794-01			2						BAND, MARKER: 0.371 DIA, WHITE, PLASTIC	80009	334-2794-01
	334-2794-02			2						BAND, MARKER: 0.371 DIA, SILVER GRAY, PLASTIC	80009	334-2794-02
	062-1803-00			1						PROBE CARD: (NOT SHOWN)	80009	062-1803-00
STANDARD ACCESSORIES												
	070-2879-00			1						MANUAL, TECH: INSTRUCTION, P6106 (NOT SHOWN)	80009	070-2879-00

CROSS INDEX—MFR. CODE NUMBER TO MANUFACTURER

Mfr. Code	Manufacturer	Address	City, State, Zip
05006	TWENTIETH CENTURY PLASTICS, INC.	415 E WASHINGTON BLVD.	LOS ANGELES, CA 90015
80009	TEKTRONIX, INC.	P O BOX 500	BEAVERTON, OR 97077