

TELEQUIPMENT
OSCILLOSCOPE
TYPE D61

MANUAL

D61 Issue 5

Amendment List 1

The following changes have been introduced.

Manual page 4/2

Paragraph 4.3.4 Vertical amplifier.

- 1.2 Last sentences should read
See para. 4.3.4 Op. 5. Disconnect test meter.
- 3.2 Last sentence should read
See para 4.3.4 Op. 6.
- 5.0 Should read Channel 1 gain (R613).

Manual page 5/6

The part numbers for circuit reference T401 have been changed to 120-0839-01 (200-240 V) or 120-0840-01 (100-120 V).

Manual figure 4

The waveform shown at the junction of R41 and TR24 collector, no longer applies.



OSCILLOSCOPE

TYPE D61

Illustrated above is the registered trade mark
of the TELEQUIPMENT division of TEKTRONIX U.K. LIMITED.

TEKTRONIX, INC.,
P.O. Box 500,
Beaverton,
Oregon (97005).

Telephone: 01-882 1166

Telephone: (503) 644-0161

Telex: 262004

Telex: 36-0485

Cables: TELEQUIPT LONDON N.14

Cables: TEKTRONIX.

© Copyright, Tektronix U.K. Ltd. (1974)

All rights reserved

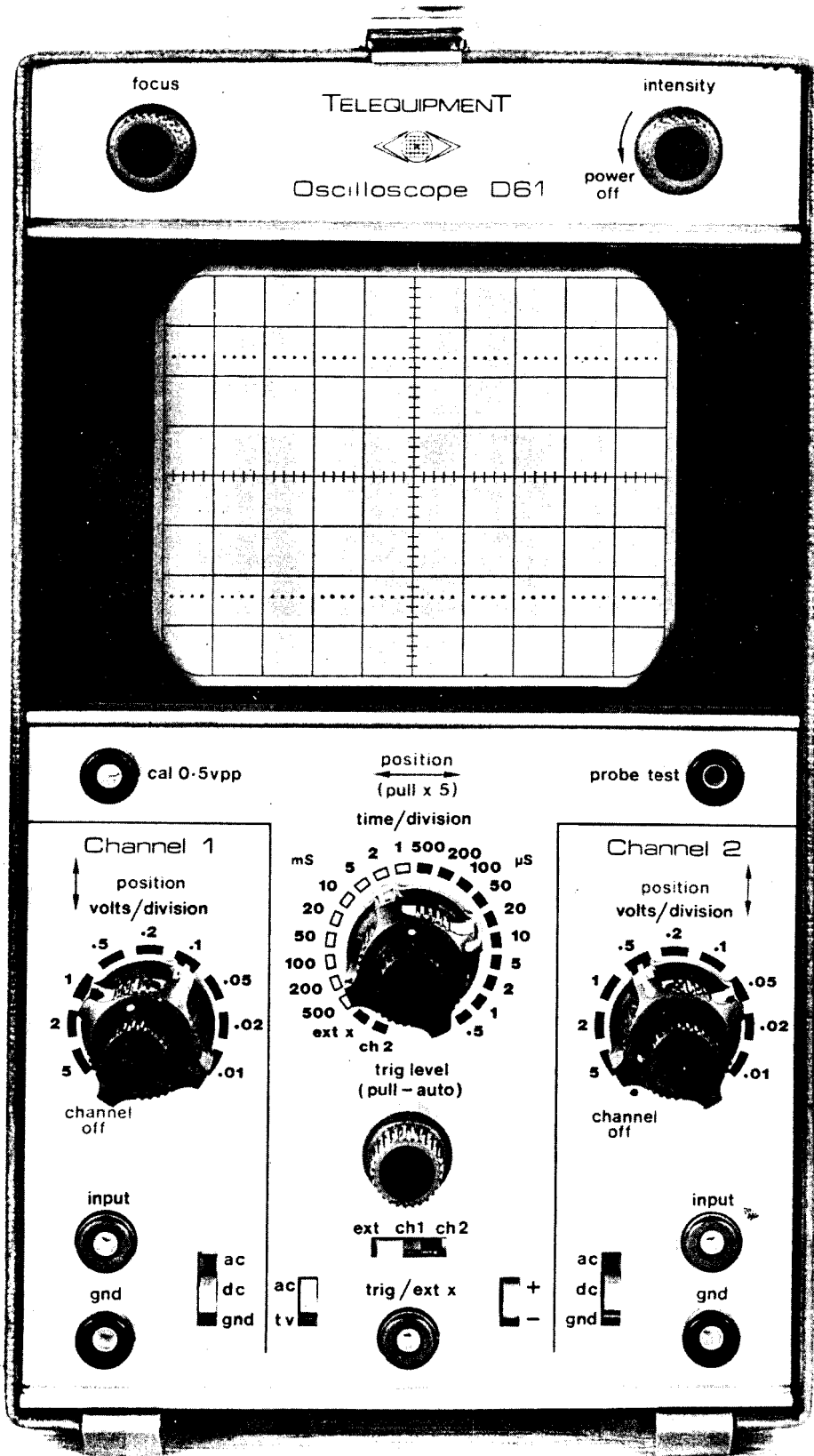

focus

TELEQUIPMENT

intensity

Oscilloscope D61

power off

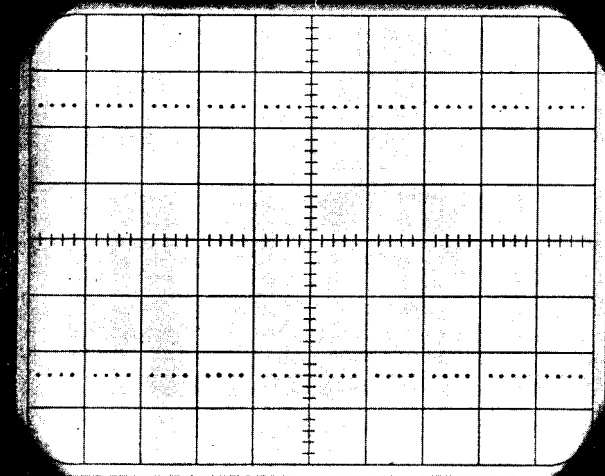

cal 0.5vpp

position
(pull x 5)

probe test

Channel 1
position
volts/division
.5 .2 .1
1 .05
2 .02
5 .01
channel off

time/division
ms 5 2 1 500 200 µs
10 20 50 100 200
500 ext x
ch 2

Channel 2
position
volts/division
.5 .2 .1
1 .05
2 .02
5 .01
channel off

trig level
(pull - auto)

input

gnd

ac
dc
gnd

ac
tv

ext ch1 ch2

trig/ext x

+
-

input

gnd

ac
dc
gnd

INTRODUCTION

The D61 is a 10 MHz all solid-state dual trace oscilloscope. An 8 x 10 cm CRT provides a bright and clear display. The vertical amplifier has a dual trace facility and displays either channel separately or alternates or chops between Channels. Channel 2 can be switched to become the horizontal amplifier to provide an X-Y display. The solid-state design using FET input circuitry provides minimum drift and fast stabilization time.

The design of this instrument is subject to continuous development and improvement, consequently this instrument may incorporate minor changes in detail from the information contained herein. This would, in the main, affect the Component List and Circuit Diagrams. The reader should pay particular attention to the notes at the beginning of Chapter 5.

NOTICE TO OWNER

In the event of this instrument being returned to TELEQUIPMENT for servicing: the owner is requested NOT to send the following items unless they are suspect, in order to prevent damage during transit and facilitate packaging:

Manual

Probes

Plug Assemblies

CONTENTS

CHAPTER		Page	CHAPTER		Page
1	SPECIFICATION		4	MAINTENANCE AND CALIBRATION	
	Cathode Ray Tube (CRT)	1/2		Calibration	
	Cooling	1/2		Astigmatism and Geometry	4/1
	Horizontal System	1/1		Calibrator	4/3
	Outputs, Front Panel	1/2		Horizontal Amplifier	4/1
	Power Supply	1/2		Initial Setting	4/1
	Size	1/2		Supply Line Voltages	4/1
	Temperature Limits	1/2		Trigger and Sweep	4/3
	Trigger	1/1		Vertical Amplifier	4/1
	Vertical System	1/1		Mechanical	
	Weight	1/2		Access to Interior	4/1
				CRT	
				Fitting	4/1
				Removal	4/1
2	OPERATING INSTRUCTIONS		5	COMPONENT LIST	
	Connectors			Assemblies	5/9
	Input	2/1		Electrical	5/2
	Output	2/1		Mechanical	5/9
	Controls				
	CRT	2/1			
	Sweep	2/1			
	Vertical	2/1			
	Operation	2/1			
	Pre-operational Checks	2/1			
	Probe Compensation	2/2			
3	CIRCUIT DESCRIPTIONS		6	CIRCUIT DIAGRAMS	Figure
	Attenuator	3/1		Power Supply & C.R.T.	5
	Bright Line Auto Circuit	3/1		Printed Circuit Board P.C.156	7
	CRT Circuit	3/2		Sweep Generator	4
	Horizontal Amplifier	3/1		Time/Div. Switch)	
	Power Supply	3/2		Volts/Div. Switch)	6
	Timebase Circuit	3/1		Trig. Input & Horizontal Amplifier	3
	Trigger Circuit	3/1		Volts/Div. Switch & Vert. Input	
	Unblanking Circuit	3/1		Amplifier	
	Vertical Amplifier			CH1	1A
	Input	3/1		CH2	1B
	Output	3/1		Wafers	
				'Y' Amplifier	2

CHAPTER 1

SPECIFICATION

1.1 VERTICAL SYSTEM

Operating Modes	Channel 1 Channel 2 Channels 1 & 2 Alternate (at time/div speeds between 1 ms and 0.5 μ s) Chop (100 kHz approx. at time/div between 500 ms and 2 ms and on EXT X) X-Y
3 dB bandwidth	
D.C. coupled	D.C. — 10 MHz
A.C. coupled	2 Hz — 10 MHz
Risetime	35 ns
Max. amplitude	5 div at 10 MHz
X-Y	Via CH1 with CH2 input selected via TIME/DIV switch as horizontal amplifier
Bandwidth (3 dB)	D.C. — 1 MHz
Deflection factors	
Calibrated (9 ranges 1, 2 & 5 sequence)	10 mV/div — 5 V/div \pm 5%
Input impedance	1 M Ω and 35 pF in parallel
Maximum input	400 V peak

1.2 HORIZONTAL SYSTEM

Sweep generator rates (19 ranges 1, 2 & 5 sequence) X5 magnification	500 ms — 0.5 μ s/div \pm 5% \geq 200 ns/div \pm 7% 100 ns/div \pm 10%
External horizontal amplifier	
3 dB bandwidth	2 Hz — 1 MHz
Deflection factor	100 mV/div approximately
Input impedance	1 M Ω and 10 pF in parallel

1.3 TRIGGER

Level	Variable Variable with auto free running in absence of trigger signal
Coupling	A.C. or TV field for sweep ranges up to 100 μ s/div and TV line from 50 μ s/div to 0.5 μ s/div
Source	CH1, CH2 or external. All positive or negative

Sensitivity

Internal

40 Hz – 1 MHz

0.5 div,
falling 1 div at 10 MHz

External

40 Hz – 1 MHz

1 MHz – 10 MHz

100 mV

1 V

1.4 CATHODE RAY TUBE (CRT)

Display area

8 x 10 cm

Phosphor

Standard

Special order

P31

P7

Overall accelerating potential

3.5 kV

1.5 OUTPUTS FRONT PANEL

Calibrator peak to peak

500 mV squarewave $\pm 2\%$ at supply frequency

Probe test

2.5 V approx. rectangular pulse at sweep repetition rate
and sweep width.

1.6 POWER SUPPLY

Voltage Model 1

100 – 120 in 10 V steps

Voltage Model 2

200 – 240 in 20 V steps

Frequency

48 – 400 Hz

Consumption

25 VA

1.7 SIZE

Height

280 mm

Width

160 mm

Depth

420 mm

1.8 WEIGHT

6.5 Kg

1.9 COOLING

Convection

1.10 TEMPERATURE LIMITS, ambient

Operating

-15 to +40°C

Non-operating

-25 to +70°C

CHAPTER 2

OPERATING INSTRUCTIONS

2.1 FUNCTION OF CONTROLS AND CONNECTORS

These are situated on the front panel except when otherwise specified.

To operate slide switches, press and slide.

2.1.1 CRT

INTENSITY varies the intensity of the display and serves as the power ON-OFF switch.

FOCUS controls the definition of the display.

2.1.2 VERTICAL

VOLTS/DIVISION provides nine steps of attenuation of the input signal. In the X-Y mode, CH1 provides the vertical input and CH2 the horizontal input.

POSITION moves the respective trace in the vertical axis and serves as the channel ON-OFF switch.

AC-DC-GND selects the input signal coupling. In the DC position, the signal from the INPUT connector is coupled directly to the attenuator. In the AC position a capacitor is inserted in series.

In the GND position the input to the amplifier is grounded; this position enables the 0 V D.C. level of a trace to be ascertained.

When not in use should be set to GND.

2.1.3 SWEEP

TIME/DIVISION selects —
Sweep speeds
EXT X
CH2 (X-Y) mode (see VOLTS/DIV)
CHOP between 500 ms/div and 2 ms/div, and on EXT X.
ALTERNATE between 1 ms/div and 0.5 μ s/div.

POSITION moves the trace in the horizontal axis and when pulled provides X5 magnification on the horizontal axis.

LEVEL selects the point on the signal waveform at which the sweep starts. When pulled selects AUTO where the timebase free runs if the level control is set beyond the range in which triggering occurs.

EXT-CH1-CH2 enables the sweep to be triggered either externally or internally from either channel of the vertical amplifier.

\pm selects triggering from the positive or negative-going slope of a waveform.

AC-TV selects either normal AC coupled triggering or triggering from:—
(1) TV field (frame) at sweep speeds between 500 ms and 100 μ s.
(2) TV line at sweep speeds between 50 μ s and 0.5 μ s.

2.1.4 CONNECTORS

INPUTS

INPUT (CH1 & CH2) the sockets connect the signal to be viewed to the respective vertical amplifiers.

TRIG/EXT X the socket connects either a triggering or EXT X signal to the trigger or horizontal circuits. Dependent on the TIME/DIV switch.

Z MOD situated on the rear panel and connected via an isolating capacitor to the CRT grid. A positive-going signal is necessary to intensify the trace while a negative-going signal will blank it. 10 V signal will give a good contrast.

CAL socket provides a waveform for checking the calibration of the vertical channels or for triggering the sweep at supply frequency.

PROBE TEST provides a rectangular pulse at timebase frequency to facilitate calibration of probes. For probe compensation, see page 2/2.

GND this is connected to the chassis of the instrument.

2.2 PRE-OPERATION CHECKS

2.2.1 SUPPLY

- Check the following:
1. Rear voltage-selector is indicating the local supply voltage or nearest value.
 2. Fuse fitted is a 500 mA on 100–120 V model and 250 mA on 200–240 V model.

Note: The 3-core supply lead is colour-coded as follows:

	LINE	NEUTRAL	GND (Chassis)
Model 1	Black	White	Green
Model 2	Brown	Blue	Green/Yellow

2.2.2 Set controls as follows:

1. CRT
 - INTENSITY Fully anti-clockwise
 - FOCUS Mid-range
2. HORIZONTAL
 - TIME/DIV 2 ms
 - POSITION Mid-range and push-in
 - TRIG LEVEL Mid-range and out
 - \pm +
 - AC/TV AC
 - EXT-CH1-CH2 CH1
3. VERTICAL
 - CH 1 & 2 0.1 V
 - POSITION (CH1 & CH2) Mid-range
 - AC-DC-GND DC

2.3 OPERATION

1. Plug into supply; turn INTENSITY clockwise — POWER ON.
2. Connect CAL to both INPUTs via co-axial cables.
3. Allow a few minutes for CRT to warm up.
4. Set TRIG for locked display.
5. Observe two traces of 5 divisions amplitude.

PROBE COMPENSATION

When using PROBE TEST output for probe compensation: apply the output via x10 probe for compensation. Select AUTO and turn TRIG LEVEL fully anticlockwise. Set TIME/DIVISION and VOLTS/DIVISION to 500 μ s and 0.05 V respectively and adjust the probe trimmer so that the leading corner of the displayed step is completely free from under and over-shoots.

The adjacent illustration shows three conditions: (A) over-compensated; (B) correctly compensated; (C) undercompensated.

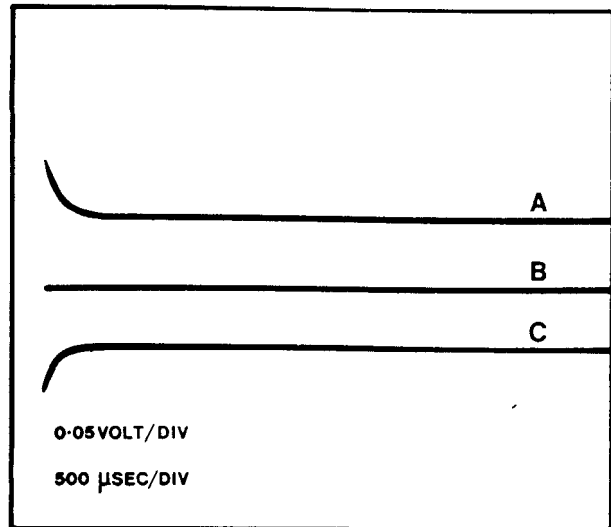

CHAPTER 3

CIRCUIT DESCRIPTION

3.0 ATTENUATOR AND VERTICAL INPUT AMPLIFIER Figures 1A & 1B

CH1 and CH2 are identical and the following description covers both channels.

The input to the attenuator is connected via C901 to the input socket SK901 on AC, directly to the input socket on DC or to ground on GND. The capacity compensated attenuator is switched by S902 wafer 1 in steps of 100, 10 and 1 and the output is fed to the gate of TR601 via C601 and R602 which, together with D601, protect the input against overloads up to ± 400 V. TR601 is a F.E.T. source follower whose output DC level is adjusted to zero by R604 and R608. The output is then attenuated in steps of 5, 2 and 1 selected by S902 wafer 2 F and fed to the base of TR603 which together with TR604 forms a longtailed pair. The diodes D602 and D603 in the emitters increase the signal handling capacity without affecting the change in gain which remains directly proportional to current and, therefore, to supply voltage. This compensates for the CRT sensitivity which is inversely proportional to supply voltage and hence the overall vertical sensitivity remains independent of supply voltage. Vertical shift is fed to the base of TR604. The gain of the channel is set up by R613 which controls the total stage emitter current. The collector currents of TR603 and TR604 pass through thermal compensating networks R611, C602 and R614, C603 and also through grounded base stage TR602 to the output stages. TR602 isolates the channel switching waveforms from the input circuit.

3.1 VERTICAL OUTPUT AMPLIFIER Figure 2

The collector currents of the selected channel pass through diodes D637 and D638 for Channel 1, or D642 and D643 for Channel 2, to the bases of shunt feedback stages TR633 and TR636. The outputs of TR633 and TR636 are fed to the bases of TR634 and TR635, a longtailed pair whose collectors feed the Y plates of the CRT. C641 and R671 in the emitter circuit are adjusted for the best pulse response and TR631 compensates for the temperature coefficient of the input stages. The appropriate channel is selected either manually by S631 and S632 which are ganged to the vertical shift controls, or automatically by the Chop/Alternate circuit TR631 and TR632. On EXT X and Time/Div speeds of 2 ms/div and slower, TR631 and TR632 operate as a free-running multivibrator at a frequency of approx. 100 kHz. When TR632 conducts D635 and D636 conduct and turn off D637 and D638 thus disconnecting Channel 1. Conversely when TR631 conducts D639 and D641 conduct and turn off D642 and D643 thus disconnecting Channel 2. C632 and C634 feed pulses to the unblanking amplifier to blank out the trace during the transitions. On Time/Div speeds above 2 ms/div, TR631 and TR632 operate as a bistable whose state is changed at the end of each timebase sweep by an edge from the emitter of TR34. The network L631, C640, R640 in CH1 and L632, C649, R669 in CH2 delay the transitions until the trace is blanked. The vertical output amplifier current supplies the +13 V line which is decoupled by C645 and also the +7.5 V line which is stabilized by zener diode D644. The +7.5 V is used as a reference for the -7.5 V line which is a shunt stabilizer circuit consisting of TR637, R659, R666, R667 and R668. R658 compensates for variations in the -13 V line and reduces the effect of supply voltage variations on the -7.5 V line.

3.2 TRIGGER CIRCUIT Figures 3 & 4

This consists of a longtailed pair TR23 and TR25 similar to the Vertical Amplifier input stage but with temperature compensation in its emitter circuit. On the CH2 position the input is connected to CH2 and on EXT X position via C20, C21, C22 and R23 to the TRIG/EXT X socket. On all other positions of

the Time/Div switch the input is connected to S20 which selects either the EXT TRIG Socket, CH1 or CH2 signal. The output from the appropriate collector, selected either by the Polarity switch S21 or the Time/Div switch S1, is connected via diode D27 or D31 to the emitter of common base stage TR26. The collector of TR26 is connected via D54, D33 and D34 to the input of the Horizontal Amplifier on CH2 and EXT X positions of the Time/Div switch S1. On other positions of the Time/Div switch the collector of TR26 is AC coupled via D32 to the base of TR21, a shunt feedback stage whose output swing is limited by diodes D21, D22 and D23. The output of TR21 is fed to the Schmitt trigger circuit, TR22 and TR24, which provides a constant amplitude trigger signal to the timebase and bright line auto circuit on the AC position of S22. On the TV position of S22, TR22 is converted to a sync separator and TR24 on TIME/DIV speeds slower than 100 μ s has a long time constant in the emitter circuit which provides positive differentiated field pulses of much greater amplitude than the line pulses. The timebase therefore triggers on the field pulses. On TIME/DIV speeds faster than 100 μ s, the emitter time constant is reduced by R50 so that the differentiated field and line pulses are of equal amplitude and the timebase therefore triggers at line frequency.

3.3 TIMEBASE, UNBLANKING AND BRIGHT LINE AUTO CIRCUIT Figure 4

3.3.1 The differentiated positive pulse from the trigger circuit is fed via D36 to the base of TR27 which together with TR29 forms a bistable. The positive pulse turns on TR27 which in turn cuts off the clamping transistor TR34. The timebase, a F.E.T. Miller circuit, then runs up linearly charging up the hold-off capacitor via D47 and resetting the bistable via R114. When TR27 cuts off, TR34 conducts and discharges the timing capacitor until D45 conducts and reduces the current in TR34 to the value required by the timing resistor. At this point the flyback stops. During the flyback the hold-off capacitor discharges through R114 until D48 conducts. At this point the action is complete and the timebase can be triggered by the next triggering pulse.

3.3.2 If the Trig level control is in the Auto position and no trigger pulses are present, TR35 and D49 conduct and reduce the potential at the anode of D48. This allows the hold-off capacitor to discharge further and re-trigger the bistable. The timebase then free-runs. If trigger pulses are present at the anode of D43 the positive pulses trigger the monostable TR32 and TR35. When triggered at frequencies above about 10 Hz the average collector current of TR35 is low and D49 is cut off returning the timebase to the normal triggered condition.

3.3.3 The collector current of TR29 which is cut off during the sweep is fed to the input of TR28. The collector of TR28 goes negative at the beginning of the sweep until diode D38 conducts and clamps the collector potential at about 3 V, thus unblanking the sweep. When TR29 conducts at the end of the sweep TR28 collector goes positive blanking the trace. On chop positions of the sweep negative edges from the chop circuit are fed to the base of TR28 to blank the trace during the transitions.

3.4 HORIZONTAL AMPLIFIER Figure 3

This consists of a shunt feedback stage TR31 with switched feedback resistors to give X5 expansion. The sweep and horizontal shift currents are mixed at the input of the shunt feedback stage and the output is fed to a longtailed pair, TR33 and TR37, which feeds the horizontal deflection plates of the CRT. D44 clamps the collector of TR33 and prevents it from bottoming.

On the EXT X and CH2 positions of the Time/Div switch the input of TR31 is switched to the collector of TR26 via D33, D34 and D54 and the X5 feedback resistor is shorted out by diodes D33, D34, D35 and D37. The trace is then deflected horizontally via the EXT X socket or from Channel 2. On these positions the gate of TR36 is connected to the cathode of D47 which clamps the output of the timebase at about +1 V and turns off TR29 thus unblanking the trace.

3.5 CRT CIRCUIT AND POWER SUPPLY Figure 5

The supply voltage is fed via the power ON/OFF switch S401, the fuse FS401 and the voltage selector SK401 to the appropriate primary tapping on T401.

- 3.5.1 The -13 V line is obtained from a full wave rectifier circuit consisting of D405, D406, C402 and R403.
- 3.5.2 The +117 V line is obtained from a bridge rectifier D401, D402, D403 and D404 with reservoir capacitor C403 and smoothed by R406 and C408 to provide the +110 V line and by R407 and C406 to provide the +80V line.

3.5.3 The -1050 V line is obtained from a half wave rectifier circuit consisting of D407, C409, C411 and C412.

3.5.4 The +2500 V line is obtained from a voltage doubler circuit consisting of D408, D409, C401 and C404.

3.5.5 The calibrator circuit provides a 0.5 V squarewave at supply frequency. It is produced by a diode switching circuit in which a current derived from the stabilized -7.5 V line is passed through D413 and R408 during negative half cycles of the AC voltage from the 13 V transformer winding. On positive half cycles D413 is cut off and the current passes through D412 and R402. The output voltage is set by R405. The temperature coefficient of the diode D413 is compensated for by the negative temperature coefficient of the output resistor R408 giving an output voltage which is nominally independent of temperature.

3.5.6 The grid voltage of the CRT is derived from a zener diode connected between the CRT cathode and the -1050 V supply. The voltage is varied by the Intensity control R301. The Intensity of the trace may be varied by signals fed via the Z Mod socket SK301 and C301 to the grid of the CRT.

CHAPTER 4

MAINTENANCE AND CALIBRATION

4.1 INTRODUCTION

4.1.1 The solid-state design of the instrument makes frequent adjustment of the internal preset components unnecessary. The appropriate part of the Calibration Procedure should be performed whenever the instrument fails to meet its specification in some particular or whenever a defective component is replaced. The Circuit Description, Chapter 3, will assist in deciding which part of the circuit requires adjustment.

4.1.2 The internal 0.5 V calibrator allows the accuracy of voltage measurement to be checked. The timing accuracy can also be checked with the internal calibrator, though it should be remembered that the frequency and frequency accuracy of the calibrator are those of the A.C. supply line.

4.1.3 To carry out the whole calibration procedure, the following tools and equipment are required:—

- Low-capacitance trimming tool (for preset capacitors).
- Small screwdriver (for preset potentiometers).
- Amplitude Calibrator, providing 1 kHz squarewave, amplitude 50 mV, amplitude accuracy within 0.25%.
- Time-mark Generator, providing markers of 1 ms, 1 μ S and, preferably, 0.5 μ S.
Accuracy within 0.1%.
- Squarewave Generator, providing outputs of 1 kHz and 10 kHz, 50 mV to 50 V.
- Squarewave Generator, providing outputs of 10 kHz, 100 kHz and 1 MHz with rise-time less than 10 ns.
- Coaxial cable and terminating resistor for the above.
- Monitor Oscilloscope, complete with X10 passive probe, and having a sweep output socket.
- Passive Probe, X10 attenuation, suitable for input capacities of 25 to 35 pF.
- Test Meter, 20,000 Ω /volt or higher, accuracy within 2% 2.5 V DC to 2500 V DC.
- Sinewave Generator, 1 kHz, 10 kHz and 50 kHz.
- Coaxial leads allowing the same signal to be connected to Channel 1, Channel 2 and the EXT socket.

4.2 MECHANICAL

4.2.1 ACCESS TO INTERIOR

The cabinet covers are removed as follows:—

1. Disconnect instrument from power supply.
2. Slacken handle-securing screws.
3. Withdraw cover from the handle ends.
4. Disengage cover from the feet pegs.

4.2.2 CRT REMOVAL

1. Remove cabinet covers as detailed in para. 4.2.1 above.
2. Earth PDA connector with a screwdriver, then disconnect.
3. Remove CRT rear cover, 3 screws.
4. Disconnect rear socket from CRT.
5. Remove the 2 clamp securing screws.
6. Remove left-hand fixing bracket (1 screw) and clamp.
7. Remove the right-hand clamp (1 screw) and move rear of CRT outwards then front end to the left and forward, removing CRT and screen from the instrument.
8. Remove tape.
9. Withdraw CRT from the screen.

4.2.3 CRT FITTING

Reverse the order detailed in para. 4.2.2 above.

4.3 CALIBRATION PROCEDURE

4.3.1 INITIAL SETTING

1. Remove side covers, reference para. 4.2.1. Connect to a suitable A.C. power source and switch the instrument on.

2. Set the front panel controls as follows:—

CH1 and CH2,	GND
AC-DC-GND	.01
VOLTS/DIV	Mid-position
POSITION	1 ms
TIME/DIV	Mid-position, push in
Horizontal POSITION	Mid-position, out (AUTO)
TRIG LEVEL	+
±	+
EXT-CH1-CH2	EXT
AC-TV	AC
FOCUS	Adjust for well defined low brilliance trace
INTENSITY	

4.3.2 SUPPLY LINE VOLTAGES (R668)

D.C. supply line voltages should normally lie within the prescribed limits when A.C. power source voltage coincides with the setting of the line voltage selector on the rear of the instrument.

The -7.5 V line is adjustable by means of R668. It should normally only require resetting when TR637 has been replaced. Note, however, that any adjustment of this line necessitates the carrying out of the entire Calibration Procedure as detailed in this Chapter.

Supply Line	Test Point	Limits
-7.5 V	CH1 POSITION potentiometer violet-blue wire	-7.3 V to -7.7 V
$+7.5$ V	CH1 POSITION potentiometer orange-white wire	$+7.1$ V to $+7.9$ V
-13 V	Horizontal POSITION potentiometer mauve-white wire	-12.4 V to -13.6 V
$+13$ V	Test point 3	$+11.9$ V to $+12.1$ V
$+80$ V	Test point 22	$+75$ V to $+85$ V
$+110$ V	Test point 29	$+107$ V to $+117$ V
-1050 V	Test point 156/7	-1060 V to -1160 V
$+2500$ V	Test point 156/K	$+2400$ V to $+2500$ V

4.3.3 ASTIGMATISM AND GEOMETRY (R305 and R307)

1. Set TIME/DIV to 100 μ s and display a 10 kHz sinewave signal on one channel only at 6 divisions vertical amplitude. Adjust FOCUS and R305 (Astigmatism) for best definition of display. Leave 10 kHz signal connected.
2. Set TIME/DIV to 1 ms. Ensure that AUTO is selected and no signal is connected to EXT. Set EXT-CH1-CH2 switch to EXT so that display becomes an unsynchronised raster. Adjust R307 so that the raster becomes as nearly as possible rectangular. Disconnect 10 kHz signal.

4.3.4 VERTICAL AMPLIFIER

- 1.0 **Channel 1 VOLTS/DIV balance (R604 and R608).**
- 1.1 Check that Channel 1 input switch is set to GND and VOLTS/DIV to 0.01. Turn Channel 1 on, Channel 2 off.
- 1.2 Connect test meter between test point C3 and chassis. Adjust R604 for zero reading.
It should normally be necessary to adjust R604 only when TR601 has been replaced. After adjustment of R604, R613 must be checked and re-adjusted if necessary. See para. 4.3.4 Op. 6. Disconnect test meter.
- 1.3 Switch Channel 1 VOLTS/DIV between 0.01, 0.02 and 0.05 positions. Adjust R608 to eliminate vertical movement of the trace.

- 2.0 **Channel 1 position balance (R618).**
- 2.1 Connect test meter between Channel 1 POSITION potentiometer moving contact (red-blue wire) and chassis. Adjust POSITION for zero reading.
- 2.2 Adjust R618 to bring the trace to the centre of the screen. Disconnect test meter.

- 3.0 **Channel 2 VOLTS/DIV balance (R704 and R708).**
- 3.1 Check that Channel 2 input switch is set to GND and VOLTS/DIV to 0.01. Turn Channel 2 on and Channel 1 off.
- 3.2 Connect test meter between test point C33 and the chassis. Adjust R704 for zero reading. Disconnect test meter. It should normally be necessary to adjust R704 only when TR701 has been replaced. After adjustment of R704, R713 must be checked and re-adjusted if necessary. See para. 4.3.4. Op. 7.
- 3.3 Switch Channel 2 VOLTS/DIV between 0.01, 0.02 and 0.05 positions. Adjust R708 to eliminate vertical movement of the trace.

- 4.0 **Channel 2 position balance (R718).**
- 4.1 Connect test meter between Channel 2 POSITION potentiometer moving contact (red-blue wire) and chassis. Adjust POSITION for zero meter reading.
- 4.2 Adjust R718 to bring the trace to the centre of the screen. Disconnect test meter.

- 5.0 **Channel 1 gain (R163).**
- 5.1 Set Channel 1 VOLTS/DIV to 0.01 and Amplitude Calibrator output to 50 mV. Display Amplitude Calibrator output on Channel 1. Adjust the amplitude of the display to exactly 5 divisions with R613. Disconnect Amplitude Calibrator.

- 6.0 **Channel 2 gain (R713).**
- 6.1 Set Channel 2 VOLTS/DIV to 0.01 and Amplitude Calibrator output to 50 mV. Display Amplitude Calibrator output on Channel 2. Adjust the amplitude of the display to exactly 5 divisions with R713. Disconnect Amplitude Calibrator.

- 7.0 **Pulse response (C641, R671 and R653)**
- 7.1 Set both VOLTS/DIV to 0.01 and display a 1 MHz squarewave signal simultaneously on both channels. (Ensure that the co-axial cable connecting the signal to the instrument is correctly terminated.)
- 7.2 Adjust C641 and R671 to optimise squarewave response on both channels. If the response of the channels is not exactly the same, adjust for best compromise.
- 7.3 Adjust R653 to minimize the change in squarewave response occurring when either POSITION control is adjusted. Disconnect squarewave signal.

- 8.0 **Attenuators (C902, C903, C904 and C905).**
Channel 1 and Channel 2 attenuators and input selector circuits are electrically identical. Corresponding components in these parts of the two channels carry the same component references.
- 8.1 Set Channel 1 input switch to DC. Display a 10 kHz squarewave of 0.5 V amplitude on Channel 1, using the 0.1 VOLTS/DIV position of the attenuator. Adjust C905 for the best response (square corner without overshoot or undershoot).
- 8.2 Set Channel 1 attenuator to 1 VOLTS/DIV and increase the amplitude of the squarewave to 5 V. Adjust C904 for best response. Disconnect squarewave signal.
- 8.3 Connect a X10 passive probe to the input of Channel 1. Set the Channel 1 VOLTS/DIV to 0.01 and display a 1 kHz squarewave of 0.5 amplitude via the probe. Adjust the probe compensation for the best squarewave response.
- 8.4 Set VOLTS/DIV to 0.1 and increase the amplitude of the squarewave to 5 V. Without altering the probe compensation, adjust C903 for the best squarewave response.
- 8.5 Set VOLTS/DIV to 1 and increase the amplitude of the squarewave to 50 V. Adjust C902 for best squarewave response. Disconnect signal and probe.
- 8.6 Repeat Ops 8.1 to 8.5 for Channel 2.

4.3.5 HORIZONTAL AMPLIFIER

- 1.0 **Output Stage balance (R108 and R113).**
- 1.1 With TIME/DIV set to 2 ms, display a 1 kHz signal (sine-wave or squarewave) on Channel 1. Adjust the horizontal POSITION control to the point where the left-hand end of the trace does not move when the X5 switch is operated. Without re-adjusting the POSITION control, bring the left-hand end of the trace to the centre vertical graticule line by adjustment of R113.
- 1.2 Position the trace centrally on the screen with the horizontal POSITION control. Adjust R108 for the best horizontal linearity at the right- and left-hand extremities of the CRT screen.

- 2.0 **Pre-amplifier balance (R37, R49 and R80).**
This operation should not be performed until any necessary adjustments to R604, R608, R704 and R708 have been done. See para. 4.3.4 Ops 1 and 3.
- 2.1 Set TIME/DIV to 2 ms, Channel 1 input switch to GND and EXT-CH1-CH2 switch to CH1. Connect test meter between test point H(+) and Chassis (-). Adjust R49 so that the test meter reading is independent of the position of the \pm switch. Disconnect the test meter.
- 2.2 Set TIME/DIV to 1 ms and adjust the left-hand end of the trace to the left-hand edge of the graticule by means of the POSITION control. Now turn TIME/DIV to CH2 and bring the spot to the centre vertical graticule line by adjusting R80.
- 2.3 Set TIME/DIV to EXT X and bring the spot to the central graticule line by adjusting R37.

- 3.0 **Channel 2 horizontal gain (R104).**
- 3.1 Set TIME/DIV to CH2. Set the output of the Amplitude Calibrator to 50 mV and connect to the input of Channel 2. Set Channel 1 input switch to GND, channel 2 input switch to DC and Channel 2 VOLTS/DIV to 0.01. Set horizontal deflection to exactly 5 divisions with R104. Disconnect Calibrator.

- 4.0 **Pulse response (C22, C26, C40 and C45).**
- 4.1 Display a 100 kHz squarewave on the monitor oscilloscope and connect the same squarewave to the D61 Channel 2 input. Connect the sweep output of the monitor oscilloscope to Channel 1 of the D61. Set TIME/DIV to CH2 and Channel 2 VOLTS/DIV to 0.01. Adjust squarewave amplitude and the remaining D61 controls to display a horizontal squarewave of about 4 divisions amplitude on a vertical timebase.
- 4.2 Adjust C40 for best response, then reduce the squarewave frequency to 10 kHz and adjust C45 (twisted wire capacitor) for the best response. Repeat the alternate adjustment of C40 at 100 kHz and C45 at 10 kHz until the response cannot be improved.

- 4.3 Disconnect the squarewave signal from the Channel 2 input and connect to the EXT socket. Set the TIME/DIV switch to EXT X and adjust the amplitude of the squarewave for a horizontal display amplitude of about 4 divisions.

With squarewave frequency of 10 kHz, adjust C25 (twisted wire capacitor) for the best response. With squarewave frequency at 100 kHz, adjust C22 (twisted wire capacitor) for best response. Repeat alternate adjustment of C22 and C26 until no further improvement is possible. Remove connexions to Channel 1 and EXT input.

4.3.6 TRIGGER AND SWEEP

1. **Trigger sensitivity (R31).**

Set EXT-CH1-CH2 switch to CH1 and display a 50 kHz sinewave signal on Channel 1. Turn R74 to its anticlockwise limit so that the timebase stops. Examine the signal at test point C66 with the monitor oscilloscope.

Adjust the input signal for an amplitude at test point C66 of about 0.5 V. Adjust the LEVEL control so that the trigger pulses occur symmetrically about the centre of the sinewave. Adjust R31 so that trigger pulses occur 25 mV apart. Disconnect Monitor Oscilloscope.

2. **Sweep stability (R74).**

Turn R74 clockwise, setting to the centre of the range in which stable triggering occurs. (This can be determined accurately by noting the change of sweep length with R74 setting.) Disconnect sinewave signal.

3. **1 ms/div sweep accuracy (R89).**

This adjustment should not be performed until any necessary adjustments have been made to R104. See para. 4.3.5 Op. 3.

Set TIME/DIV to 1 ms and display 1 ms markers from the Time Marker Generator on Channel 1. Adjust R89 so that markers are exactly one major division apart over the centre 8 divisions. Leave Time Marker Generator connected.

4. **Sweep Length (R77).**

Adjust sweep length to 10.5 divisions with R77. Leave Time Marker Generator connected.

5. **0.5 μ s/div sweep accuracy (C2).**

Set Time Marker Generator to 0.5 μ s and TIME/DIV to 0.5 μ s. Adjust C2 (mounted on TIME/DIV switch) so that one marker occurs for each major division over the centre 8 divisions. (Alternatively, set Time Marker Generator to 1 μ s and adjust for one marker every 2 divisions). Disconnect Time Marker Generator.

4.3.7 INTERNAL CALIBRATOR (R405).

The internal calibrator amplitude should be adjusted only after Channel 1 and 2 vertical gain has been checked and corrected. See para. 4.3.6 Ops 6 and 7. Set Channel 1 and 2 input switches to DC, both VOLTS/DIV switches to 0.1 and display internal calibrator signal on both channels simultaneously. Adjust the mean amplitude of the Channel 1 and 2 displays to exactly 5 divisions with R405.

CHAPTER 5

COMPONENTS LIST

Values of resistors are stated in ohms or multiples of ohms; ratings at 70°C are in watts or sub-multiples of watts. Values of capacitors are stated in sub-multiples of farads; ratings at 70°C are in volts or kilovolts.

Whenever possible, exact replacements for components should be used, although locally available alternative may be satisfactory for standard components.

Any order for replacement parts should include:

- | | |
|--------------------------------|--------------------------|
| 1. Instrument type | 4. Component part number |
| 2. Instrument serial number | 5. Component value |
| 3. Component circuit reference | |

CIRCUIT REFERENCE BLOCKS

The table below gives the blocks of circuit references, so that the reader can relate the items listed in this chapter and their location in the circuitry and printed circuit boards in Chapter 6.

Circuit Reference		Circuit	Fig.
From	To		
1	300	Horiz. Amplifier	3
		Sweep & Time/div Switch	4
301	400	CRT	5
401	600	Power Supply	
601	650	Vertical input	1A
701	750		1B
651	900	Vertical amplifier	2
901	1000	Volts/div switch	1

ABBREVIATIONS

BM Button mica	CMP Cermet preset	PS Polystyrene
C Carbon	E Electrolytic	Se Selenium
CP Carbon preset	Ge Germanium	Si Silicon
CV Carbon variable	MF Metal Film	SM Silver mica
CER Ceramic	MO Metal oxide	WW Wire-wound
CT Ceramic Trimmer	PE Polyester	WWP Wire-wound preset
CM Cermet thick film	PP Polypropylene	WWW Wire-wound variable

TELEQUIPMENT, division of TEKTRONIX U.K. LIMITED

313 Chase Road Southgate London N14 6JJ England

Telephone: 01-882 1166 Telex: 262004 Cables: TELEQUIPT LONDON N14

All requests for repairs or replacement parts should be directed to the Tektronix Field Office or representative in your area. This procedure will assure you the fastest possible service.

CIR REF	PART NUMBER	VALUE F	DESCRIPTION		
			TYPE	TOL %	RATING V
C1	285-0867-00	20 p	PS	1 p	350
C2	281-0137-00	6-30 p	CT		350
C3	285-0943-00	1.0 μ	PC	1	63
C4	285-0942-00	10 n	PS	1	125
C5	285-1057-00	50 p	PS	1 p	350
C6	285-0791-00	470 n	PE	10	125
C7	285-0792-00	4.7 n	PE	20	125
C20	281-0696-00	0.75 p	CER	0.1 p	500
C21	285-0773-00	100 n	PE	20	400
C22		Twisted pair			
C23	290-0623-00	4.7 μ	E		25
C24	281-0711-00	3.9 p	CER	0.25 p	750
C25	281-0723-00	1.8 p	CER	0.1 p	500
C26		Twisted pair			
C27	285-0759-00	2.2 n	PS	5	125
(1162) C28	285-0850-00	1 n	PS	5	125
C29	285-0869-00	47 p	PS	2 p	350
(1058) C30	285-0759-00	2.2 n	PS	5	125
C32	285-0854-00	100 p	PS	2 p	350
C33	290-0546-00	15 μ	E		16
C34	285-0759-00	2.2 n	PS	5	125
C35	281-0676-00	2.2 p	CER	0.1 p	500
(1077) C36	285-0887-00	1.5 n	PS	5	125
C37	285-0982-00	82 p	PS	1 p	350
C38	290-0664-00	4.7 μ	E		160
C39	285-0776-00	27 p	PS	1 p	350
C40	281-0157-00	5.5-65 p	PP		500
C41	285-0779-00	470 n	PE	20	100
C42	285-1063-00	390 p	PS	5	160
C43	290-0625-00	4.7 μ	E		160
C44	285-0887-00	1.5 n	PS	5	125
C45		Twisted pair			
C46	281-0710-00	10 n	CER		250
C48	285-0866-00	10 p	PS	1 p	350
C49	281-0710-00	10 n	CER		250
C51	281-0710-00	10 n	CER		250
C52	281-0734-00	100 n	CER		30
(1058) C53	281-0710-00	10 n	CER		250
(1164) C54	285-0867-00	20 p	PS	1 p	350
C55	285-0869-00	47 p	PS	2 p	350
C56	290-0664-00	4.7 μ	E		160
C57	281-0710-00	10 n	CER		250
C58	290-0669-00	330 μ	E		16
(1069) C59	285-0915-00	100 n	PE	20	100
C301	281-0677-00	10 n	CER		2 k
C302	281-0710-00	10 n	CER		250
C303	281-0710-00	10 n	CER		250
C304	285-0788-00	100 n	PE	10	125
C401	281-0706-00	30 n	CER		1.5 k
C402	290-0659-00	2.2/2.2 m	E		16
C403	290-0400-00	330 μ	E		160
C404	281-0681-00	10 n	CER		4 k
C405	285-0874-00	470 p	PS	5	125
C406	290-0660-00	100 μ	E		100
C408	290-0400-00	330 μ	E		160

CIR REF	PART NUMBER	VALUE F	DESCRIPTION		
			TYPE	TOL %	RATING V
C409	290-0540-00	15 μ	E		450
C411	290-0540-00	15 μ	E		450
C412	290-0540-00	15 μ	E		450
C601	285-1058-00	10 n	PE	20	400
C602	285-0850-00	1 n	PS	5	125
C603	285-0847-00	560 p	PS	5	125
C630	285-0810-00	820 p	PS	5	125
C631	285-0854-00	100 p	PS	2 p	350
C632	285-1063-00	390 p	PS	5	160 (1069)
C633	285-1015-00	4.7 n	PE	20	160
C634	285-1063-00	390 p	PS	5	160 (1069)
C635	285-0872-00	180 p	PS	2	350
C636	281-0710-00	10 n	CER		250
C637	285-0854-00	100 p	PS	2 p	350
C638	281-0678-00	3 p	CER	0.1 p	500
C639	285-0810-00	820 p	PS	5	125
C640	285-0760-00	330 p	PS	5	125
C641	281-0157-00	5.5-65.5 p	PP		500
C642	285-0872-00	180 p	PS	2	350 (1128)
C643	285-0915-00	100 n	PE	20	100
C644	281-0678-00	3 p	CER	0.1 p	500 (1069)
C645	290-0579-00	1 m	E		16
C646	290-0663-00	470 μ	E		10
C647	290-0627-00	22 μ	E		40
C648	290-0663-00	470 μ	E		10
C649	285-0760-00	330 p	PS	5	125
C650	281-0710-00	10 n	CER		250
C652	285-0872-01	180 p	PS	2	350
C653	281-0710-00	10 n	CER		250
C654	281-0710-00	10 n	CER		250
C701	285-1058-00	10 n	PE	20	400
C702	285-0850-00	1 n	PS	5	125
C703	285-0847-00	560 p	PS	5	125
C704	281-0710-00	10 n	CER		250
C901	285-0772-00	100 n	PE	10	400
C902	281-0137-00	6-30 p	CT		350
C903	281-0137-00	6-30 p	CT		350
C904	281-0137-00	6-30 p	CT		350
C905	281-0137-00	6-30 p	CT		350
C906	285-0854-00	100 p	PS	2	350
C907	285-0850-00	1 n	PS	5	125

CIR REF	PART NUMBER	VALUE	DESCRIPTION	TYPE	TOL %	RATING
D21	152-0062-01	75 V	1N914	Si		50 mA
D22	152-0062-01	75 V	1N914	Si		50 mA
D23	152-0062-01	75 V	1N914	Si		50 mA
D24	152-0062-01	75 V	1N914	Si		50 mA
D25	152-0062-01	75 V	1N914	Si		50 mA
D26	152-0062-01	75 V	1N914	Si		50 mA
D27	152-0062-01	75 V	1N914	Si		50 mA
D28	152-0062-01	75 V	1N914	Si		50 mA
D29	152-0062-01	75 V	1N914	Si		50 mA
D30	152-0062-01	75 V	1N914	Si		50 mA
D31	152-0062-01	75 V	1N914	Si		50 mA
D32	152-0062-01	75 V	1N914	Si		50 mA
D33	152-0062-01	75 V	1N914	Si		50 mA
D34	152-0062-01	75 V	1N914	Si		50 mA
D35	152-0062-01	75 V	1N914	Si		50 mA
D36	152-0062-01	75 V	1N914	Si		50 mA
D37	152-0062-01	75 V	1N914	Si		50 mA
D38	152-0062-01	75 V	1N914	Si		50 mA
D39	152-0062-01	75 V	1N914	Si		50 mA
D40	152-0062-01	75 V	1N914	Si		50 mA
D41	152-0062-01	75 V	1N914	Si		50 mA
D42	152-0062-01	75 V	1N914	Si		50 mA
D43	152-0062-01	75 V	1N914	Si		50 mA
D44	152-0062-01	75 V	1N914	Si		50 mA
D45	152-0062-01	75 V	1N914	Si		50 mA
D46	152-0062-01	75 V	1N914	Si		50 mA
D47	152-0062-01	75 V	1N914	Si		50 mA
D48	152-0062-01	75 V	1N914	Si		50 mA
D49	152-0062-01	75 V	1N914	Si		50 mA
D51	152-0062-01	75 V	1N914	Si		50 mA
D52	152-0062-01	75 V	1N914	Si		50 mA
D53	152-0062-01	75 V	1N914	Si		50 mA
D54	152-0062-01	75 V	1N914	Si		50 mA
D55	152-0062-01	75 V	1N914	Si		50 mA
(1128) D301	152-0610-00	82 V	Zener	Si	5	770 mW
D401	152-0566-00	200 V	SD2	Si		1 A
D402	152-0566-00	200 V	SD2	Si		1 A
D403	152-0566-00	200 V	SD2	Si		1 A
D404	152-0566-00	200 V	SD2	Si		1 A
D405	152-0339-00	50 V	1N4001	Si		500 mA
D406	152-0339-00	50 V	1N4001	Si		500 mA
D407	152-0567-00	3 kV	SCM30	Si		
D408	152-0567-00	3 kV	SCM30	Si		
D409	152-0567-00	3 kV	SCM30	Si		
D411	152-0062-01	75 V	1N914	Si		50 mA
D412	152-0062-01	75 V	1N914	Si		50 mA
D413	152-0062-01	75 V	1N914	Si		50 mA
D601	152-0483-00	10 V	C1104	Si		50 mA
(1209) D602	152-0062-02	75 V	1N4148T	Si		50 mA
(1209) D603	152-0062-02	75 V	1N4148T	Si		50 mA

CIR REF	PART NUMBER	VALUE	DESCRIPTION	TYPE	TOL %	RATING
D631	152-0062-01	75 V	1N914	Si		50 mA
D632	152-0062-01	75 V	1N914	Si		50 mA
D633	152-0062-01	75 V	1N914	Si		50 mA
D634	152-0062-01	75 V	1N914	Si		50 mA
(1160) D635	152-0614-00	75 V	1N4448	Si		50 mA
(1160) D636	152-0614-00	75 V	1N4448	Si		50 mA
(1162) D637	152-0614-00	75 V	1N4448	Si		50 mA
(1162) D638	152-0614-00	75 V	1N4448	Si		50 mA
(1160) D639	152-0614-00	75 V	1N4448	Si		50 mA
(1160) D641	152-0614-00	75 V	1N4448	Si		50 mA
(1162) D642	152-0614-00	75 V	1N4448	Si		50 mA
(1162) D643	152-0614-00	75 V	1N4448	Si		50 mA
D644	152-0347-00	7.5 V	Zener	Si	5	330 mW
D645	152-0062-01	75 V	1N914	Si		50 mA
D646	152-0062-01	75 V	1N914	Si		50 mA
D701	152-0483-00	10 V	C1104	Si		50 mA
(1209) D702	152-0062-02	75 V	1N4148T	Si		50 mA
(1209) D703	152-0062-02	75 V	1N4148T	Si		50 mA

CIR REF	PART NUMBER	VALUE	DESCRIPTION
(1187) FB23	276-0597-00		Ferrite bead
FS401	159-0077-00	250 mA	Fuse Delay 1.25" 200-240V
or	159-0079-00	500 mA	Fuse Delay 1.25" 100-120V
(1162) L21	108-0483-00	16 μH	Fixed Inductor
L631	108-0482-00	160 μH	Fixed Inductor
L632	108-0482-00	160 μH	Fixed Inductor

CIR REF	PART NUMBER	VALUE	DESCRIPTION	TOL %	RATING W
(1128) R1	325-0175-00	2.37 M	MF	1	1
(1128) R2	325-0174-00	787 k	MF	1	500 m
(1128) R3	325-0173-00	392 k	MF	1	250 m
(1128) R4	325-0172-00	237 k	MF	1	250 m
(1128) R5	325-0171-00	78.7 k	MF	1	250 m
(1128) R6	325-0171-00	78.7 k	MF	1	250 m

(1283) R20	317-0474-01	470 k	C	5	125 m
(1283) R21	311-1734-00	47 k	CV	20	150 m
R22	317-0473-01	47 k	C	5	125 m
R23	317-0914-01	910 k	C	5	125 m
(1283) R24	317-0623-01	62 k	C	5	125 m
R25	317-0332-01	3.3 k	C	5	125 m
(1283) R26	317-0333-01	33 k	C	5	125 m
R27	317-0332-01	3.3 k	C	5	125 m
(1162) R28	317-0752-01	7.5 k	C	5	125 m

CIR REF	PART NUMBER	VALUE Ohms	DESCRIPTION TYPE	TOL %	RATING W
R29	317-0223-01	22 k	C	5	125 m
R30	317-0271-01	270	C	5	125 m (1162)
R31	311-1503-00	100	C	20	75 m
R32	317-0824-01	820 k	C	5	125 m
R33	317-0332-01	3.3 k	C	5	125 m
R34	317-0682-01	6.8 k	C	5	125 m
R35	317-0392-01	3.9 k	C	5	125 m
R36	317-0103-01	10 k	C	5	125 m
R37	311-1513-00	47 k	CP	20	75 m
R38	317-0330-01	33	C	5	125 m
R39	317-0224-01	220 k	C	5	125 m (1077)
R41	317-0561-01	560	C	5	125 m (1162)
R42	317-0151-01	150	C	5	125 m (1162)
R43	317-0332-01	3.3 k	C	5	125 m
R44	317-0682-01	6.8 k	C	5	125 m
R45	317-0392-00	3.9 k	C	5	125 m
R46	317-0221-01	220	C	5	125 m
R47	317-0332-01	3.3	C	5	125 m
R48	317-0183-01	18 k	C	5	125 m
R49	311-1512-00	22 k	CP	20	75 m
R50	317-0474-01	470 k	C	5	125 m (1077)
R51	317-0103-01	10 k	C	5	125 m (1162)
R52	317-0512-01	5.1 k	C	5	125 m
R53	317-0682-01	6.8 k	C	5	125 m
R54	317-0393-01	39 k	C	5	125 m
R55	317-0682-01	6.8 k	C	5	125 m
R56	317-0183-01	18 k	C	5	125 m
R57	317-0822-01	8.2 k	C	5	125 m
R58	317-0273-01	27 k	C	5	125 m
R59	317-0512-01	5.1 k	C	5	125 m

CIR REF	PART NUMBER	VALUE Ohms	DESCRIPTION		
			TYPE	TOL %	RATING W
R60	317-0100-01	10	C	5	125 m
R61	317-0332-01	3.3 k	C	5	125 m
R62	317-0243-01	24 k	C	5	125 m
R63	317-0104-01	100 k	C	5	125 m
R64	317-0222-01	2.2 k	C	5	125 m
R65	317-0123-01	12 k	C	5	125 m
R66	317-0183-01	18 k	C	5	125 m
R67	303-0113-01	11 k	C	5	1
R68	321-0306-48	15 k	MF	1	125 m
R69	311-1525-00	22 k	CV	20	250 m
R70	317-0470-01	47	C	5	125 m
R71	317-0272-01	2.7 k	C	5	125 m
(1193) R72	317-0302-01	3 k	C	5	125 m
R73	317-0203-01	20 k	C	5	125 m
R74	311-1510-00	10 k	CP	20	75 m
R75	317-0123-01	12 k	C	5	125 m
R76	317-0222-01	2.2 k	C	5	125 m
R77	311-1510-00	10 k	CP	20	75 m
R78	317-0103-01	10 k	C	5	125 m
R79	315-0393-02	39 k	C	5	250 m
R80	311-1511-00	15 k	CP	20	75 m
R81	317-0102-01	1 k	C	5	125 m
R82	321-1257-48	4.7 k	MF	1	125 m
R83	317-0183-01	18 k	C	5	125 m
R84	317-0203-01	20 k	C	5	125 m
R85	317-0332-01	3.3 k	C	5	125 m
R86	317-0103-01	10 k	C	5	125 m
R87	317-0334-01	330 k	C	5	125 m
R88	317-0512-01	5.1 k	C	5	125 m
R89	311-1512-00	22 k	CP	20	75 m
1067) R90	317-0151-01	150	C	5	125 m
R91	317-0432-01	4.3 k	C	5	125 m
R92	307-0143-00	5.6 k	MO	5	1.5
R93	315-0122-02	1.2 k	C	5	250 m
R94	317-0431-01	430	C	5	125 m
R95	317-0274-01	270 k	C	5	125 m
R96	317-0224-01	220 k	C	5	125 m
R97	317-0822-01	8.2 k	C	5	125 m
1160) R98	317-0101-01	100	C	5	125 m
(1128) R99	317-0203-01	20 k	C	5	125 m
R101	317-0471-01	470	C	5	125 m
R102	317-0564-01	560 k	C	5	125 m
R103	317-0101-01	100	C	5	125 m
R104	311-1505-00	220	CP	20	75 m
R105	301-0203-01	20 k	C	5	500 m
R107	315-0122-02	1.2 k	C	5	250 m
R108	311-1507-00	1 k	CP	20	75 m
R109	307-0143-00	5.6 k	MO	5	1.5
R111	301-0223-01	22 k	C	5	500 m
R112	317-0561-01	560	C	5	125 m
R113	311-1532-00	330	CP	20	75 m
R114	317-0473-01	47 k	C	5	125 m
R115	317-0103-01	10 k	C	5	125 m
R116	317-0223-01	22 k	C	5	125 m
R117	317-0391-01	390	C	5	125 m
R118	317-0123-01	12 k	C	5	125 m
R119	317-0100-01	10	C	5	125 m
R121	317-0105-01	1 M	C	5	125 m
R123	317-0303-01	30 k	C	5	125 m
R124	317-0562-01	5.6 k	C	5	125 m
1058) R125	317-0100-01	10	C	5	125 m
1058) R126	317-0100-01	10	C	5	125 m

CIR REF	PART NUMBER	VALUE Ohms	DESCRIPTION		
			TYPE	TOL %	RATING W
R301	311-1020-00	1.0 M	CV	20	250 m
R302	316-0155-01	1.5 M	C	10	250 m
R303	311-1516-00	1 M	CV	20	250 m
R304	317-0394-01	390 k	C	5	125 m
R305	311-1514-00	220 k	CP	20	75 m
R306	317-0105-01	1 M	C	5	125 m
R307	311-1514-00	220 k	CP	20	75 m
R308	316-0106-01	10 M	C	10	250 m
R309	315-0222-01	2.2 k	C	5	250 m (1105)
*R401	316-0563-01	56 k	C	10	250 m
R401	316-0184-01	180 k	C	10	250 m
R402	317-0103-01	10 k	C	5	125 m
R403	317-0220-01	22	C	5	125 m
R404	321-1325-48	24 k	MF	1	125 m
R405	311-1510-00	10 k	CP	20	75 m
R406	315-0201-03	200	C	5	250 m
R407	308-0753-00	620	WW	5	3
R408	317-0222-01	2.2 k	C	5	125 m
R601	321-0481-48	1 M	MF	1	125 m
R602	317-0104-01	100 k	C	5	125 m
R603	317-0101-01	100	C	5	125 m
R604	311-1504-00	150	CP	20	75 m
R605	317-0132-01	1.3 k	C	5	125 m
R608	311-1510-00	10 k	CP	20	75 m
R611	317-0562-01	5.6 k	C	5	125 m
R612	317-0432-01	4.3 k	C	5	125 m
R613	311-1509-00	4.7 k	CP	20	75 m
R614	317-0123-01	12 k	C	5	125 m
R615	317-0223-01	22 k	C	5	125 m
R616	317-0223-01	22 k	C	5	125 m
R617	317-0181-01	180	C	5	125 m
R618	311-1512-00	22 k	CP	20	75 m
R619	311-1526-00	22 k	CV	20	250 m
R621	317-0223-01	22 k	C	5	125 m

CIR REF	PART NUMBER	VALUE Ohms	DESCRIPTION		
			TYPE	TOL %	RATING W
R631	317-0184-01	180 k	C	5	125 m
R632	317-0103-01	10 k	C	5	125 m
R633	317-0223-01	22 k	C	5	125 m
(1211) R634	317-0203-01	20 k	C	5	125 m
R635	317-0331-01	330	C	5	125 m
(1211) R636	315-0103-01	10 k	C	5	250 m
R637	317-0122-01	1.2 k	C	5	125 m
R638	317-0123-01	12 k	C	5	125 m
(1211) R639	317-0203-01	20 k	C	5	125 m
R640	317-0681-01	680	C	5	125 m
R641	317-0331-01	330	C	5	125 m
R642	317-0184-01	180 k	C	5	125 m
R643	317-0103-01	10 k	C	5	125 m
R644	317-0223-01	22 k	C	5	125 m
R645	317-0302-01	3 k	C	5	125 m
(1128) R647	315-0103-01	10 k	C	5	250 m
R648	317-0682-01	6.8 k	C	5	125 m
R649	307-0407-00	1.3 k	MO	5	1.5
R651	315-0911-01	910	C	5	250 m
R652	317-0560-01	56	C	5	125 m
R653	311-1507-00	1 k	CP	20	75 m
R654	317-0330-01	33	C	5	125 m
R655	307-0407-00	1.3 k	MO	5	1.5
R656	315-0911-01	910	C	5	250 m
R657	317-0682-01	6.8 k	C	5	125 m
R658	317-0683-01	68 k	C	5	125 m
(1058) R659	315-0181-01	180	C	5	250 m
(1128) R661	315-0103-01	10 k	C	5	250 m
R663	317-0162-01	1.6 k	C	5	125 m
R664	317-0302-01	3 k	C	5	125 m
R665	317-0271-01	270	C	5	125 m
R666	317-0752-01	7.5 k	C	5	125 m
R667	317-0682-01	6.8 k	C	5	125 m
R668	311-1508-00	2.2 k	CP	20	75 m
R669	317-0681-01	680	C	5	125 m
(1058) R671	311-1532-00	330	CP	20	75 m
R672	317-0274-01	270 k	C	5	125 m
R673	317-0123-01	12 k	C	5	125 m
R674	317-0274-01	270 k	C	5	125 m
R701	321-0481-48	1 M	MF	1	125 m
R702	317-0104-01	100 k	C	5	125 m
R703	317-0101-01	100	C	5	125 m
R704	311-1504-00	150	CP	20	75 m
R705	317-0132-01	1.3 k	C	5	125 m
R708	311-1510-00	10 k	CP	20	75 m
R711	317-0562-01	5.6 k	C	5	125 m
R712	317-0432-01	4.3 k	C	5	125 m
R713	311-1509-00	4.7 k	CP	20	75 m
R714	317-0123-01	12 k	C	5	125 m
R715	317-0223-01	22 k	C	5	125 m

CIR REF	PART NUMBER	VALUE Ohms	DESCRIPTION		
			TYPE	TOL %	RATING W
R716	317-0223-01	22 k	C	5	125 m
R717	317-0181-01	180	C	5	125 m
R718	311-1512-00	22 k	CP	20	75 m
R719	311-1526-00	22 k	CV	20	250 m
R721	317-0223-01	22 k	C	5	125 m
R722	317-0223-01	22 k	C	5	125 m
R900	317-0100-01	10	C	5	125 m
R901	321-0989-48	990 k	MF	1	125 m
R902	321-0988-48	900 k	MF	1	125 m
R903	321-1389-48	111 k	MF	1	125 m
R904	321-1289-48	10.1 k	MF	1	125 m
R905	325-0141-00	162	MF	1	250 m
R906	321-0843-48	270	MF	1	125 m
R907	321-0101-48	110	MF	1	125 m
R908	317-0750-01	75	C	5	125 m
R909	317-0622-01	6.2 k	C	5	125 m
R911	307-0382-00	7.5	C	5	125 m
S1	260-1535-00				Rotary Time/Div
S20	260-1307-00				Slide EXT-CH1-CH2
S21	260-1307-00				Slide + -
S22	260-1307-00				Slide AC-TV
S23	with R69/S1				Push-Pull X1 - X5
S24	with R21				Push-Pull AUTO
S401	with R301				Power On/Off
S631	with R719				Rotary CH2 - Off
S632	with R619				Rotary CH1 - Off
S901	260-1307-00				Slide AC GND DC
S902	260-1534-00				Rotary Volts/Div
SK301	136-0542-00				Socket Z Mod
SK401	136-0541-00				Volt Selector
SK901	131-1654-00				Socket Input
T401	120-0839-00 or 120-0840-00				Transformer 200 - 240 V Transformer 100 - 120 V
TH21	307-0408-00	50 Ω	VA1034	20	1/2 W
TH631	307-0408-00	50 Ω	VA1034	20	1/2 W

CJR REF	PART NUMBER	DESCRIPTION	TYPE	RATING
TR21	151-0127-02	BSX20	Si	NPN
TR22	151-0320-00	MPS 6518	Si	PNP
TR23	151-0317-01	BC109C	Si	NPN
TR24	151-0320-00	MPS 6518	Si	PNP
TR25	151-0326-01	BC107	Si	NPN
TR26	151-0320-00	MPS 6518	Si	PNP
TR27	151-0326-01	BC107	Si	NPN
TR28	151-0257-03	FRB 749	Si	NPN
TR29	151-0326-01	BC107	Si	NPN
TR31	151-0326-01	BC107	Si	NPN
TR32	151-0326-01	BC107	Si	NPN
TR33	151-0257-03	FRB 749	Si	NPN
TR34	151-0320-00	MPS 6518	Si	PNP
TR35	151-0326-01	BC107	Si	NPN
(1165) TR36	151-1076-00	F.E.T. TEL. SPEC.	Si	N.Channel
TR37	151-0257-03	FRB 749	Si	NPN
(1165) TR601	151-1076-00 } 151-1076-01 }	F.E.T. TEL. SPEC.	Si	N.Channel
TR602	151-0326-01	BC107	Si	NPN
TR603	151-0317-01	BC109C	Si	NPN
TR604	151-0326-01	BC107	Si	NPN
TR631	151-0320-00	MPS 6518	Si	PNP
TR632	151-0320-00	MPS 6518	Si	PNP
TR633	151-0127-02	BSX20	Si	NPN
TR634	151-0310-00	TEL. SPEC.	Si	NPN
TR635	151-0310-00	TEL. SPEC.	Si	NPN
TR636	151-0127-02	BSX20	Si	NPN
TR637	151-0401-00	BC263C	Si	PNP
(1165) TR701	151-1076-00 } 151-1076-01 }	F.E.T. TEL. SPEC.	Si	N.Channel
TR702	151-0326-01	BC107	Si	NPN
TR703	151-0317-01	BC109C	Si	NPN
TR704	151-0326-01	BC107	Si	NPN
V301	154-0693-00 154-0693-01	CRT G.E.C. Type 1324Y P31 CRT G.E.C. Type 1346Y P7		
V401	150-0105-00	Lamp Neon 34L. Power On		

focus



TELEQUIPMENT



Oscilloscope D61

intensity



power off

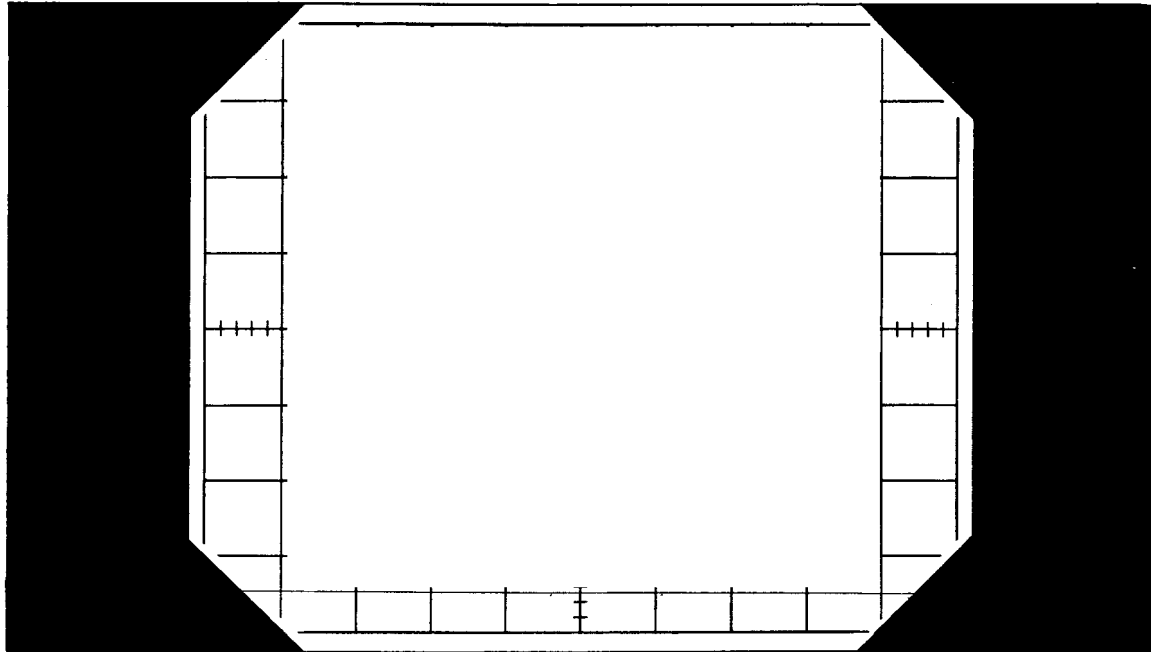

cal 0.5vpp

position
(pull x 5)

probe test

Channel 1

position
volts/division

.5 .2 .1 .05 .02 .01

1 2 3 4 5

channel off

input

gnd

ac dc

gnd tv

5

time/division

ms 2 1 500 200 100 50 20 10 5 2 1 .5

10 20 50 100 200 500

ext x ch 2

trig level
(pull - auto)

2

ext ch1 ch2

trig/ext x

6

Channel 2

position
volts/division

.5 .2 .1 .05 .02 .01

1 2 3 4 5

channel off

input

gnd

ac dc

gnd tv

5

PANEL, FRONT. LOWER.

MECHANICAL

PART NUMBER	DESCRIPTION	LOCATION
012-0168-00	Cable Input Head	Accessory
175-0805-00	Cable Red	Accessory
175-0806-00	Cable Black	Accessory
200-0927-00	Cap, PDA	
344-0253-00	Clip, neon	
344-0166-00	Clip Crocodile 4 off	Accessory
131-0644-00	Connector, button	CRT
	Cover, protective	
	upper	Accessory
437-0129-00	lower	Accessory
437-0158-00	Cover, side	
437-0155-00	Foot, LH	
(1291) 348-0357-02	RH	
291) 348-0357-03	raising member	
348-0358-00	Fuse holder	PCB
352-0265-00	Graticule	
	Standard, CRT	1
331-0347-01	P7, CRT	
331-0347-03	Handle	
367-0182-00	clip	
101-0024-00	Key, Allen 1.5 A/F	Accessory
003-0674-00	Knob, grey/black	2
366-1239-00	Knob, grey/black	3
366-1241-00	Knob, red	4
366-1355-01	Packaging	Accessory
004-0872-00	Plug 4 mm, single pole 4 off	Accessory
134-0098-00	Screw, set, 3 x 3 mm	2, 3, 4
213-0248-00	Sleeve Black 2 off	Accessory
200-0968-00	Sleeve Red 2 off	Accessory
200-0967-00	Socket	
	black	5
136-0542-00	CRT	
136-0302-00	red	6
136-0543-00	Wallet	Accessory
006-1197-00		

ASSEMBLIES

ASSEMBLY	PART NUMBER	INCLUDES CIRCUIT REFERENCES
PC 156	670-2928-00	All components except those* in chapter 6.
Switch AC-TV	262-0971-00	C28, C33, C36, R42, R45, R47, R50, R52, S22.
Switch TIME/DIV	262-0968-00	C1 to C7, R1 to R6, S1.
Switch VOLTS/DIV	262-0967-00	C901 to C907, R901 to R909, S902.

CHAPTER 6

CIRCUIT DIAGRAMS

To minimize the risk of misinterpretation of component values on circuit diagrams, the decimal point has been replaced by the multiplier or sub-multiplier of the basic unit. For instance, 2.2 megohms is shown as 2M2 and 1.8 picofarads is shown as 1p8.

To aid the reader further, in addition to the block Circuit Reference Table in Chapter 5.1, to locate a component in the circuit diagrams, a table is provided at the top of each circuit diagram, in which the circuit reference will appear, where practicable, directly above the component being sought.

STORS	901	902	903	904	905	906	907	908	909	910	911	912	913	914	915	916	917	918	919
ACATORS	601	602	603	604	605	606	607	608	609	610	611	612	613	614	615	616	617	618	619
IC	5901	5902	5903	5904	5905	5906	5907	5908	5909	5910	5911	5912	5913	5914	5915	5916	5917	5918	5919
D1*	TR601	TR602	TR603	TR604	TR605	TR606	TR607	TR608	TR609	TR610	TR611	TR612	TR613	TR614	TR615	TR616	TR617	TR618	TR619

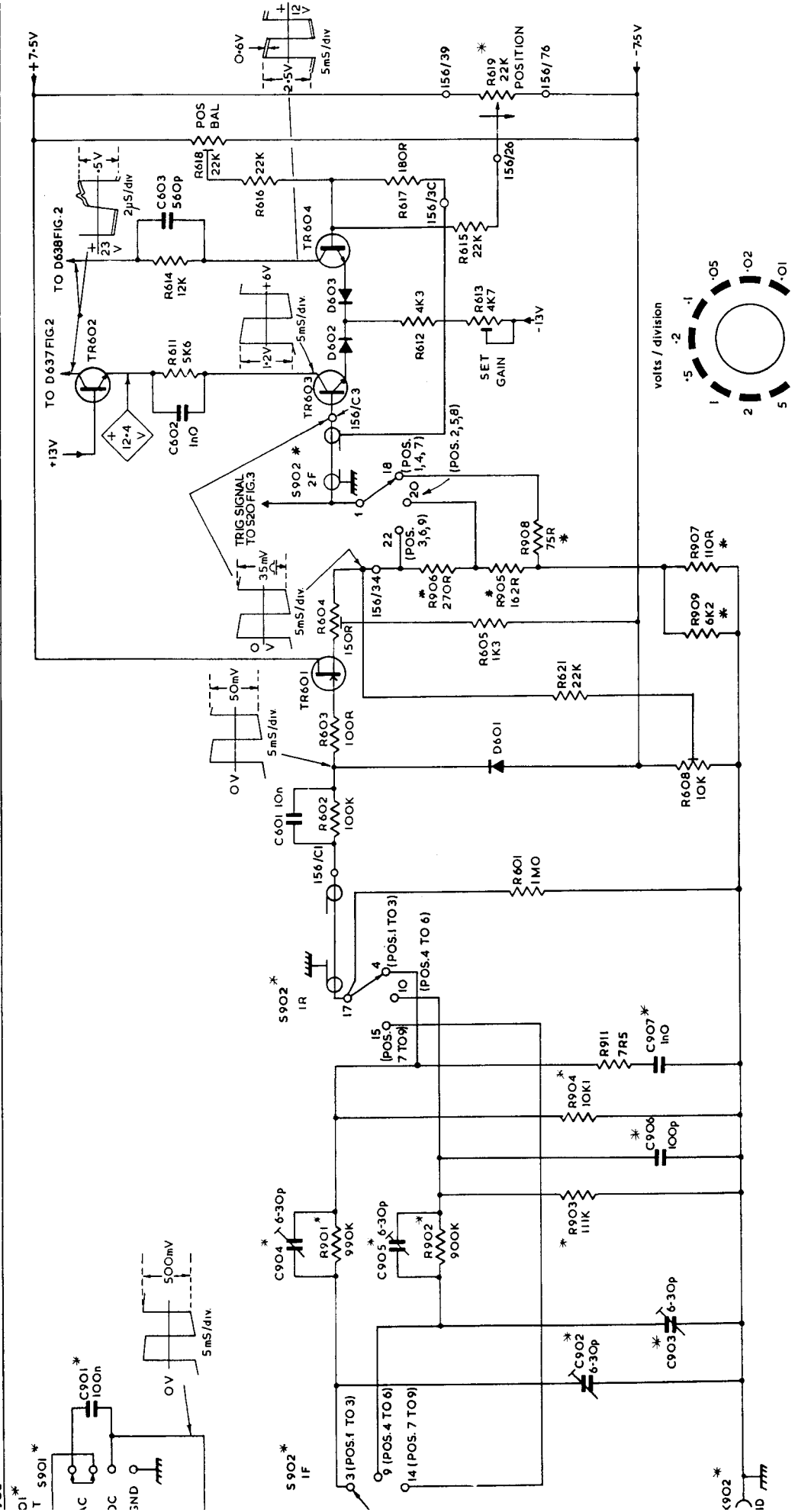

NOTES:

1. 156/CI DENOTES PC BOARD/EYELET OR TERMINAL No. CONNECTION
2. * DENOTES COMPONENTS NOT MOUNTED ON PC BOARD.
3. SWITCH IS SHOWN IN FULLY ANTICLOCKWISE POSITION.
4. ALL WAVEFORMS MEASURED WITH CAL WAVEFORM FED TO BOTH CHANNELS. VOLTS/DIV SET TO 0.1 TRIG SELECTOR TO CH.1 AND TIME/DIV. TO 2ms

FRONT PANEL MARKING

VOLTS/DIV. SWITCH. & VERT. INPUT AMPLIFIER CH.1 D61

FIG. 1A

RESISTORS	669	631 632	672 673	634	644	633	639	642 643	640
			635		636 637		641	674 638	
CAPACITORS	631	649	630 635	632	633	634	652 639	640	637 653 636
MISC.		L632 SI-2F S631 D632	TR631				TR632 SI-2F D646	L631 D634	S632

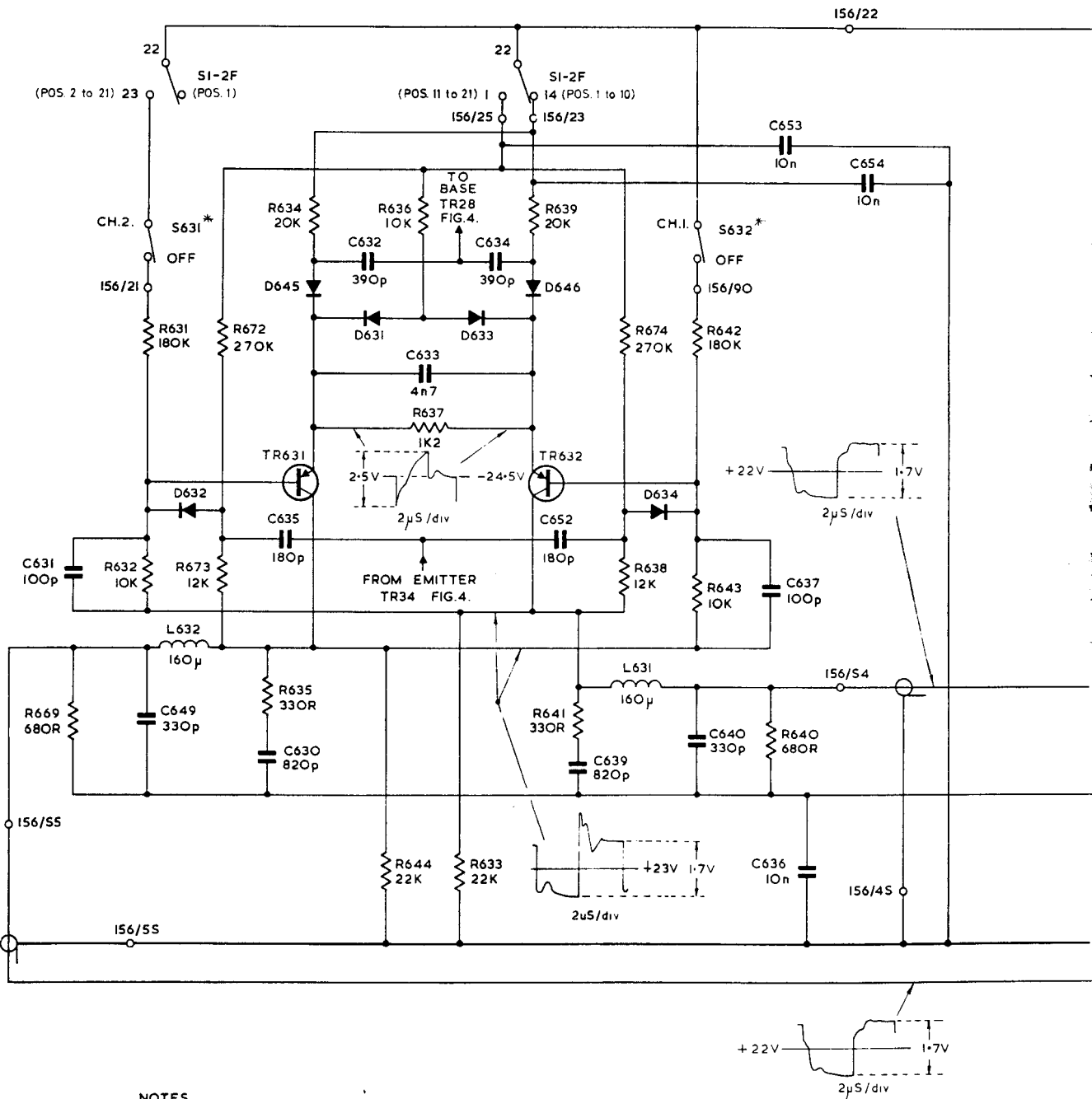

NOTES.

- * DENOTES COMPONENTS NOT MOUNTED ON P.C. BOARD.
- 156/55 DENOTES P.C. BOARD/EYELET OR TERMINAL No. CONNECTION.
- ALL WAVEFORMS MEASURED WITH CAL WAVEFORM FED TO BOTH CHANNELS VOLTS/DIV SET TO 0.1 TRIG SELECTOR TO CH.1 AND TIME/DIV TO 2mS.

664	661 653	647 663	645	648	649 651	652	671 665	654 658	655 656 668 667 666	657	659
					645	638	647	644			
					642 641	646 648				643	
	TR636	TR633			TR634			TH631	TR635		
	D635 D637	D638 D636	D643 D639	D641 D642					TR637		
							D644				

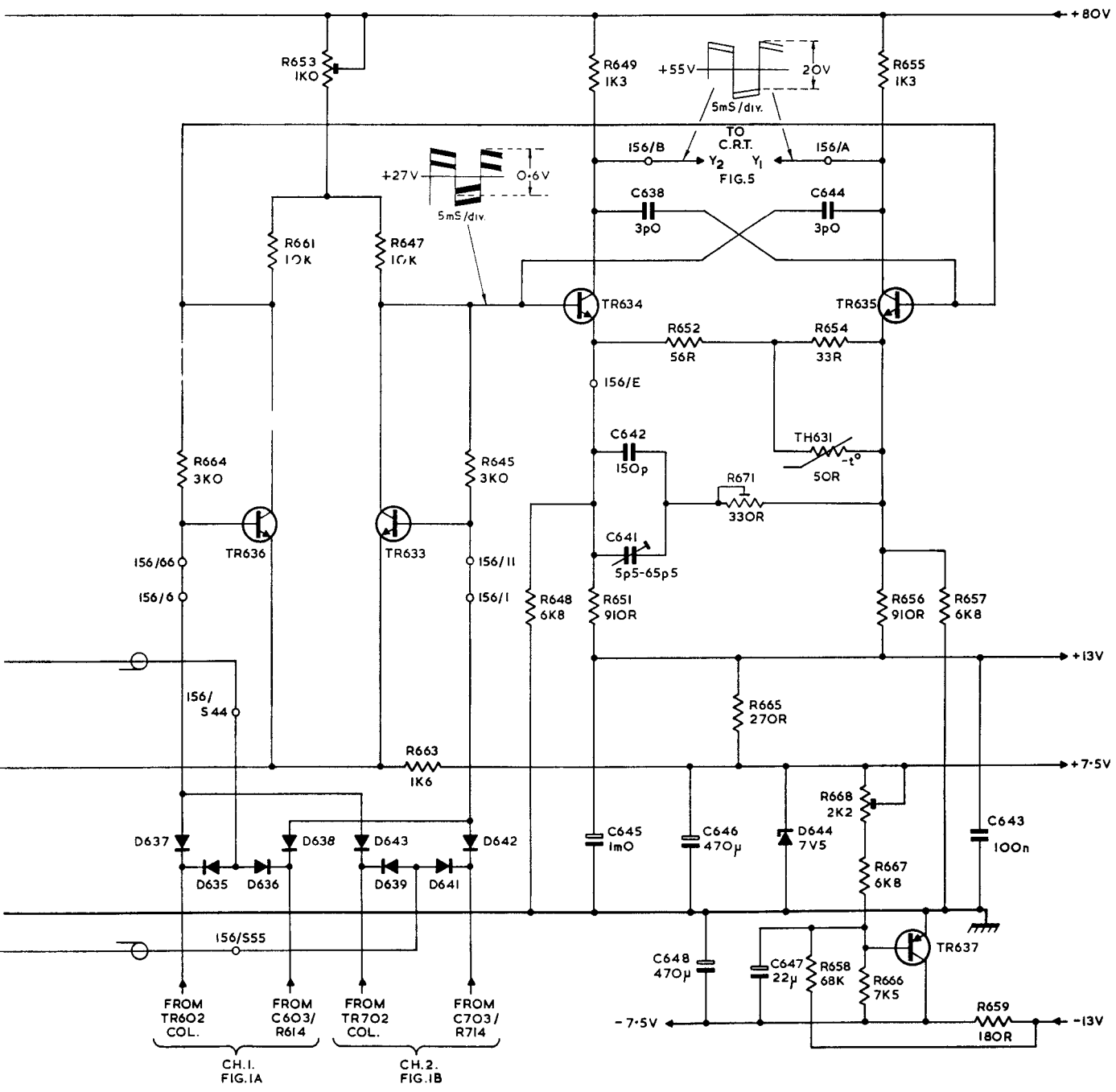

'Y' AMPLIFIER - D61
FIG. 2.

RESISTORS	23	37	32		33	38	43	46	48	49	52
					34		44				
		121			125		126				
CAPACITORS											
	21	20	22	26	25	27		34		51	
		61						30	35		
MISC.					FB23	TR23	TH21	TR25			
						D24	D26	D28			
						D25	D27	D29			
										D31	
SK21	S20	SI-IF		SI-IR	S21						

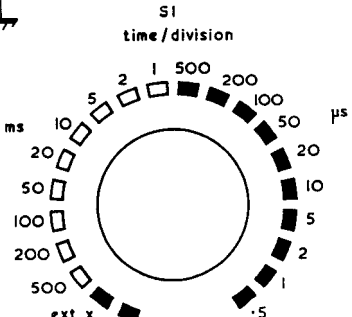
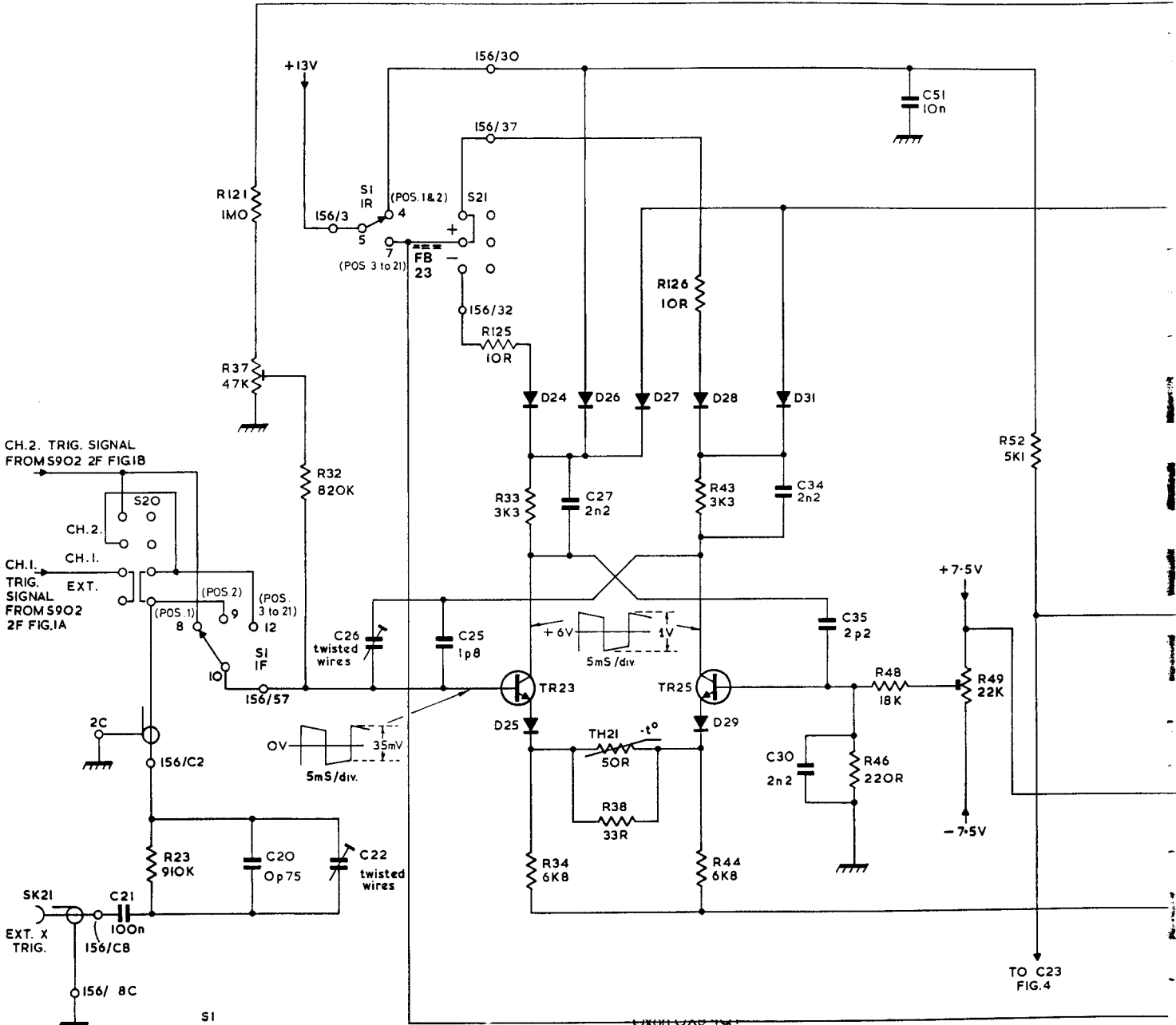

- NOTES.
- * DENOTES COMPONENTS NOT MOUNTED ON P.C. BOARD.
 - 156/C8 DENOTES P.C. BOARD/EYELET OR TERMINAL No.CONNECTION
 - SWITCH SHOWN IN FULLY ANTI-CLOCKWISE POSITION.
 - FOR SI SWITCH WAFERS SEE FIG.6.
 - ALL WAVEFORMS MEASURED WITH CAL WAVEFORM FED TO BOTH CHANNELS VOLTS/DIV. TO 0.1 TRIG SELECTOR TO CH.1 AND TIME/DIV TO 2ms.

RESISTORS	22	24	25	27	28	29	35	36	39	45	47	50
	21		26			31			41			71
CAPACITORS	23	59	24			29			32	33	28	51
										36		52
MISC.		D21	D22		TR21	TR22		TR24		S22		SI-2F
	S24		D23						L21	FB21		
	R20									FB22		D30

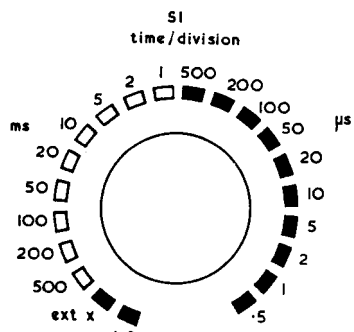
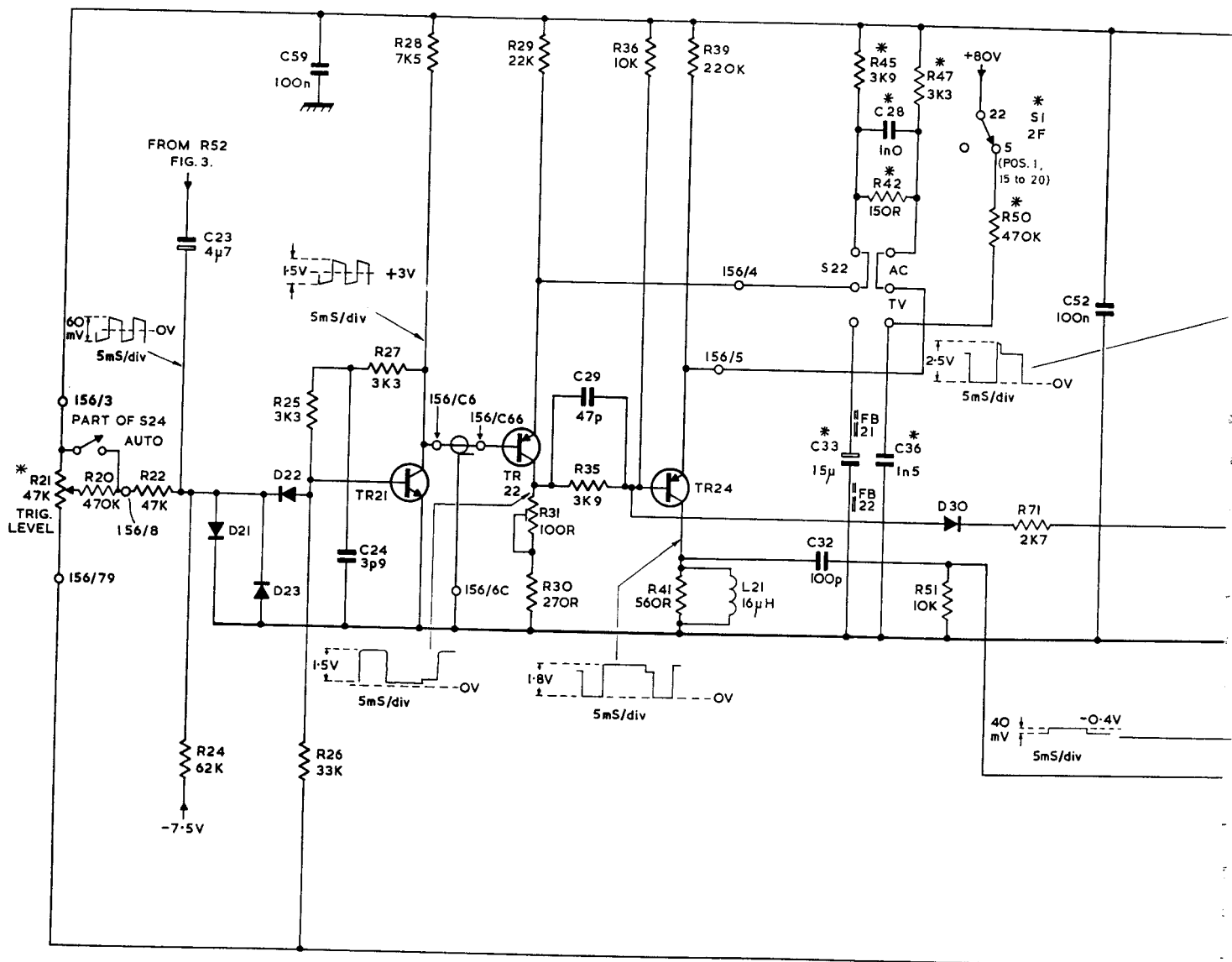

NOTES

- * DENOTES COMPONENTS NOT MOUNTED ON P.C. BOARD.
- 156/6C DENOTES P.C. BOARD/EYELET OR TERMINAL No. CONN.
- SWITCH SHOWN IN FULLY ANTI-CLOCKWISE POSITION.
- FOR SI SWITCH WAFERS SEE FIG. 6.
- ALL WAVEFORMS MEASURED WITH CAL. WAVEFORM FED TO BOTH CHANNELS, VOLTS/DIV. SET TO 0.1, AND TRIG. SELECTOR TO CH.1. AND TIME/DIV. TO 2MS.
- PUSH PULL SWITCH S24 IS SHOWN IN THE OUT POSITION

84	88	6	72	101	105	114	95	115	102	96	97	91	54	86
85		5					75	116					62	87
	61	4					73	117					58	67
	78	3	77				74	118					59	
	63	2												119
		1												
		39	3	4	5	7	6	54		43	41	38	57	
					49		48				46			
D36	D52	D53	SI-2R	SI-3R	D46	SI-3F	D48	D51	D49	S24		D40	D38	D43
SK22	D45				TR36	D47					TR35	TR32	D38	TR28
TR34	TR27				D39	TR29								

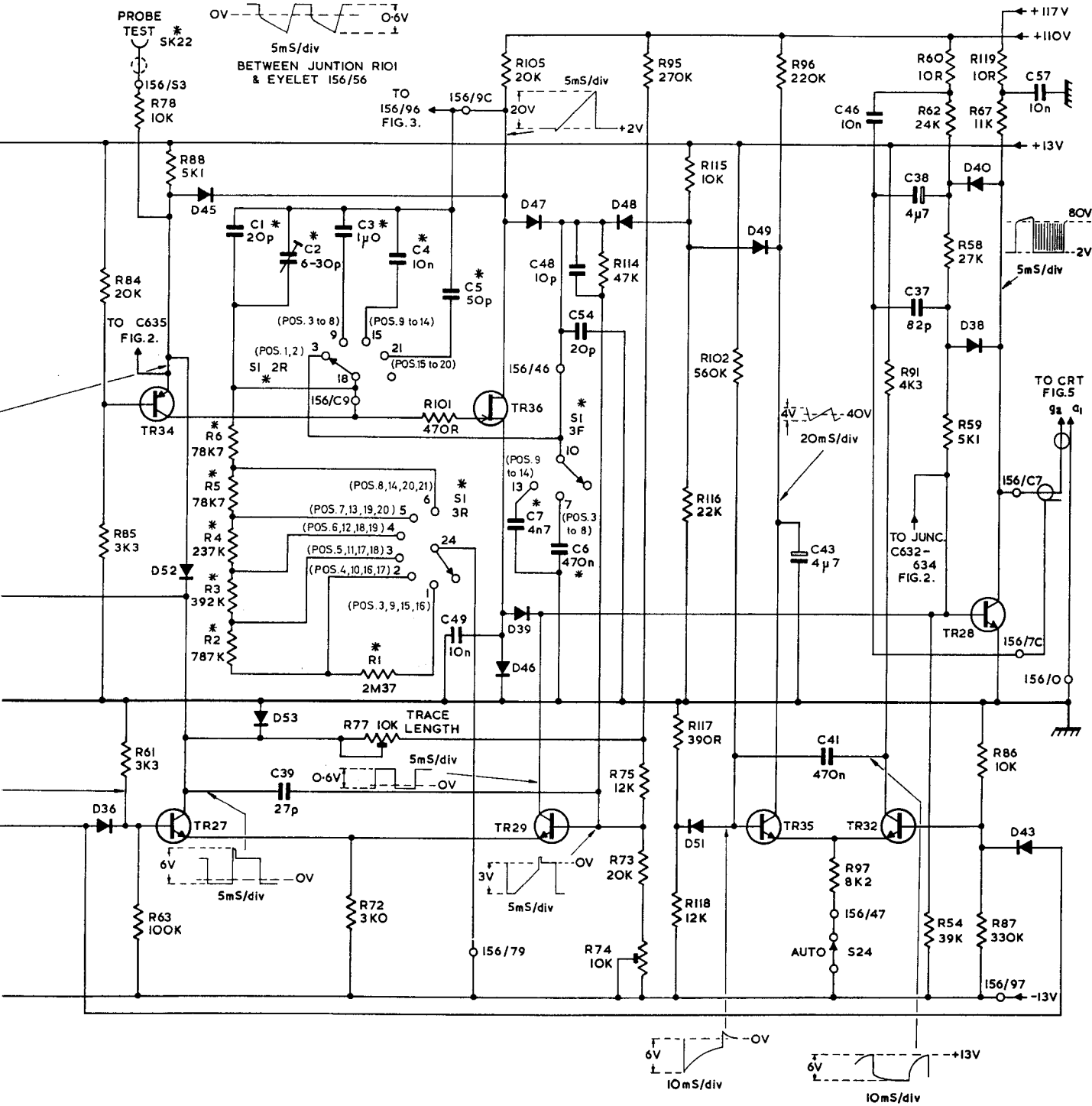

SWEEP GENERATOR D61
FIG. 4.

RESISTORS	401			402	403	404	405	406	407	408	
CAPACITORS			401		402	403	404	405		406	
MISC.	V401	FS401	SK401	T401	D401	D402	D408	D409	D411	D413	SK402
	S401				D404	D403			D412		
					D405	D407					
					D406						

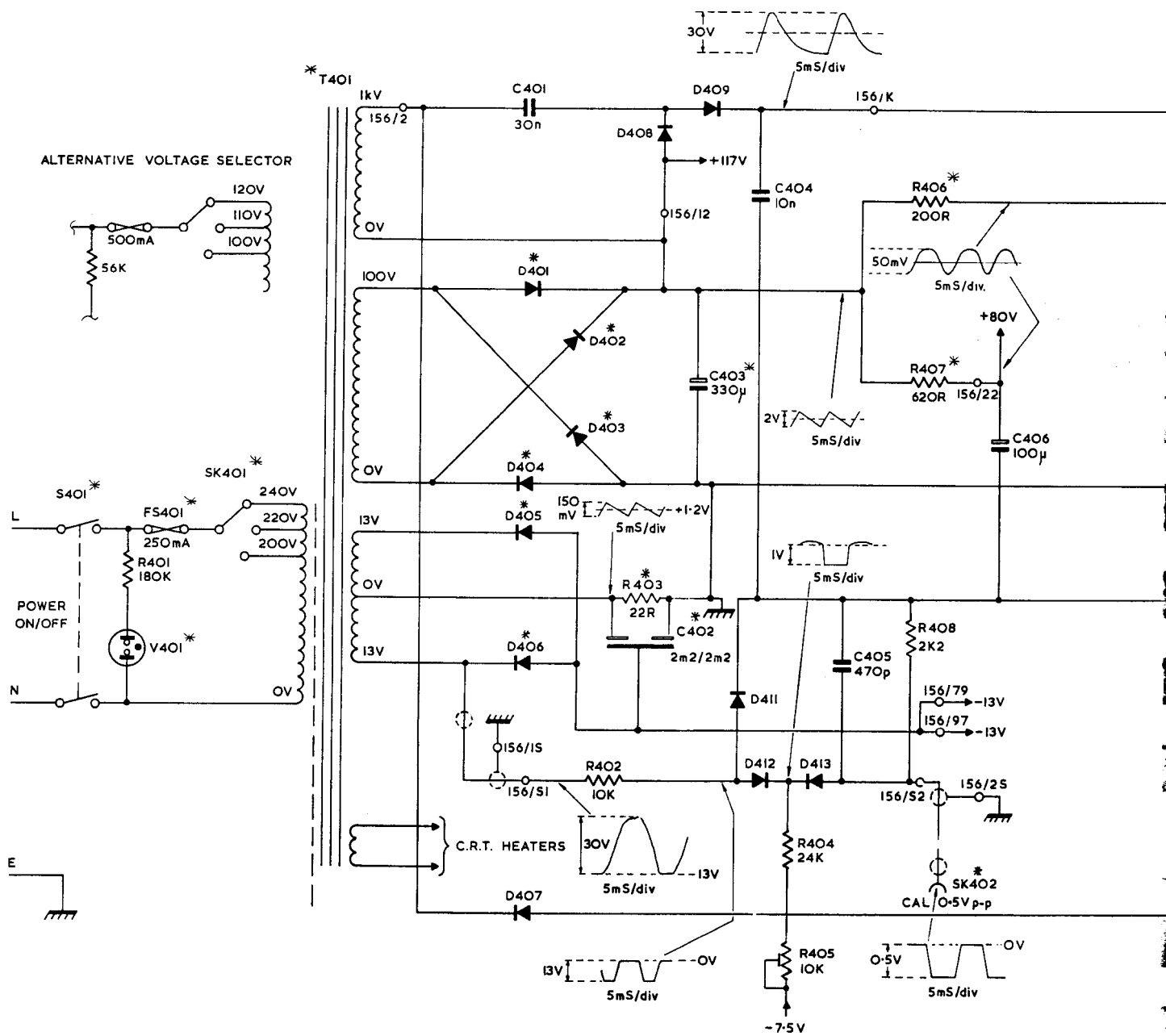

NOTES.

- * DENOTES COMPONENTS NOT MOUNTED ON P.C. BOARD.
- 156/2 DENOTES P.C. BOARD/EYELET OR TERMINAL No. CONNECTION
- ALL WAVEFORMS MEASURED WITH CAL. WAVEFORM FED TO BOTH CHANNELS, VOLTS/DIV. SET TO 0.1, AND TRIG. SELECTOR TO CH.1. AND TIME/DIV. TO 2mS.

	301 302 303 304	305 306	307 308
309			
408 409 411 412		302 301	303
		304	
D301		SK301	V301

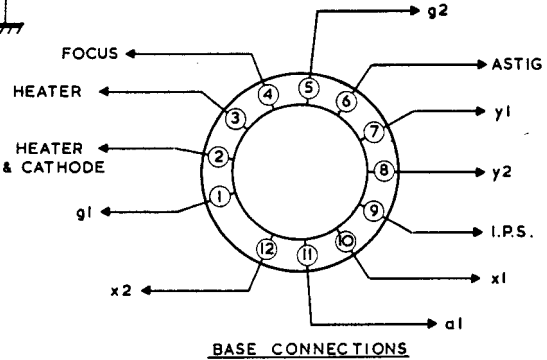
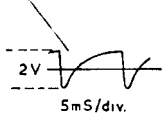
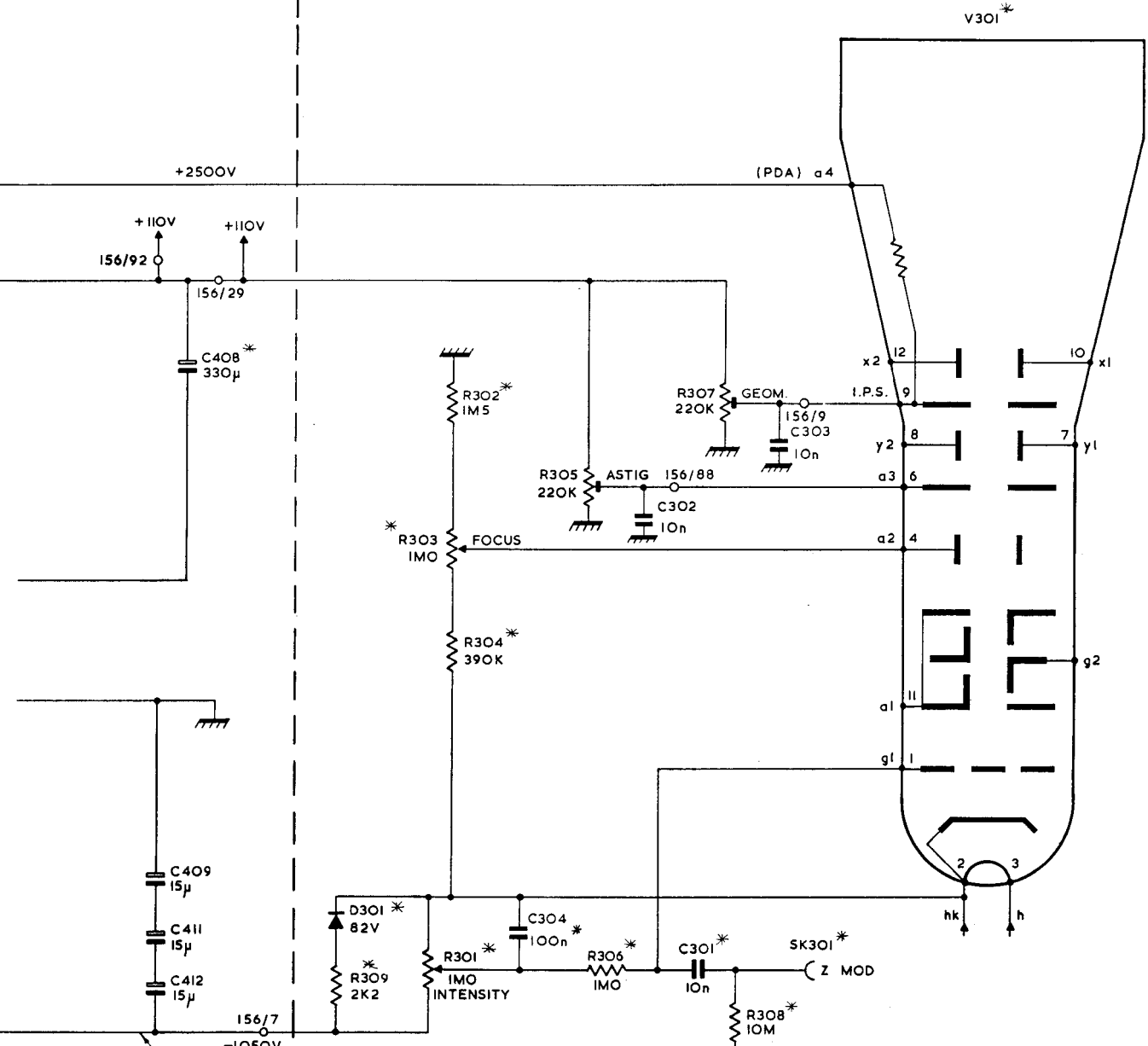

POWER SUPPLY & C.R.T. - D61

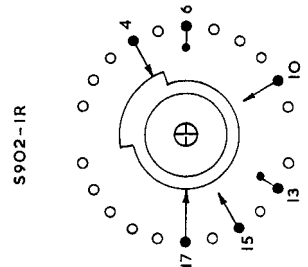
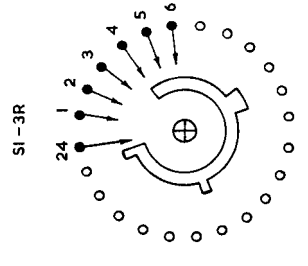
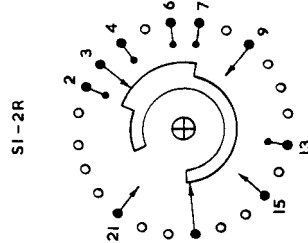
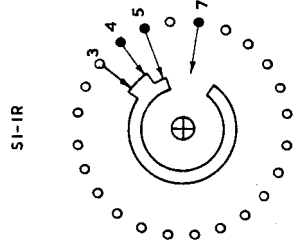
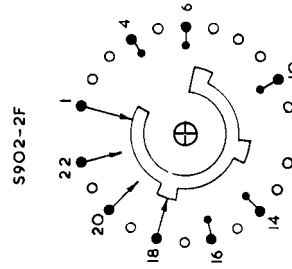
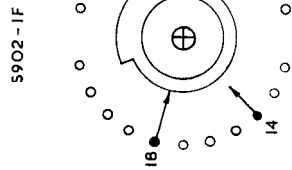
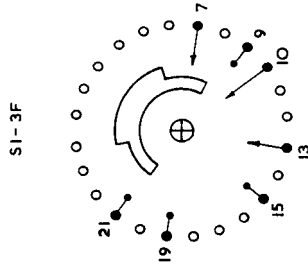
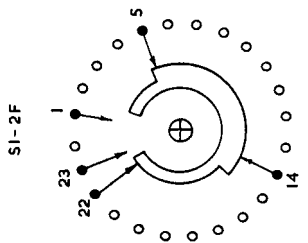
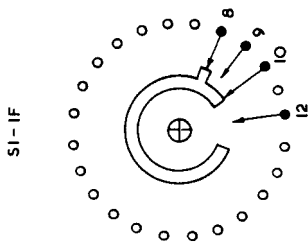

NOTES.
1. SWITCH IS SHOWN IN FULLY ANTICLOCKWISE POSITION
2. No. OF POSITIONS 21

NOTES.
1. SWITCH IS SHOWN IN FULLY ANTICLOCKWISE POSITION
2. No. OF POSITIONS 9

TIME/DIV. SWITCH

FIG. 6

VOLTS/DIV. SWITCH

