

component news

Aug. 24, 1979

COMPANY CONFIDENTIAL

Issue 273

Tantalum prices soar

Alternatives for tantalum caps sought

Tektronix uses over five million tantalum capacitors per year. This is mainly due to their small size, low ESR and DC leakage, and moderate price. Due to recent fantastic increases in the price of tantalum, only two of the above three advantages still hold true. In the past three months, the price of most solid tantalum caps has increased by 20% to 60%. The price of the ore has not stabilized, and may not for a long time, meaning further price increases are inevitable.

Tantalum is a dense refractory metal that is moderately common in nature. But sources for commercial ores are relatively scarce and much of the tantalum ore comes from third world countries. Their political instability has made it risky for companies to expand. Production in many of the established mines is on the decline, and new sources will be slow in coming on line.

Beginning in late 1973 the demand for tantalum ore outstripped the supply by a small margin, and this situation has continued to the present time. The recent price rise has been influenced by speculators responding to rumors that the US Government Services Administration was going to increase its strategic stockpile by an amount equal to one and one-half years of worldwide consumption.

Here's an example of the current market situation. Tantalum powder suppliers purchase ore (30% Ta₂O₅) on the London Metals Exchange. In 1973 it sold for \$6 per pound. By the fall of 1978 it

was \$28 per pound; in March of 1979 it increased to \$40 per pound, jumped to \$68 per pound in early May, and by June it was at \$88 per pound. It is expected to reach \$125 per pound by the end of the year, with price increases occurring about every three months.

This rapid increase in raw material price has overwhelmed any productivity increases that the manufacturers could make, and has led some manufacturers to increase prices three times this year. Most manufacturers have now instituted a "pass through" program where all ore price increases are directly passed on to the user. For example, one manufacturer of hermetically-sealed axial lead solid tantalums said that for every \$4.00 increase in ore price, there will be the following increases in finished product price:

Case A (dia. 0.125" x 0.25")	+ 2%
Case B (0.18" x 0.56")	+ 4%
Case C (0.29" x 0.69")	+ 5%
Case D (0.35" x 0.79")	+ 7%

Tantalum is used in chemical equipment because of its very stable oxide, and large quantities have been designed into the next generation of engines for commercial jets. Tantalum pentoxide is used as a dielectric in capacitors because it is very stable (long life), has a very high dielectric constant ($K \approx 25$), a high breakdown voltage, and can easily be electrochemically formed on tantalum metal foil or sintered powder slugs.

continued on page 2

Also in this issue

Capacitors, tubular variable
ESD damage
IC sockets

page 7
8
7

LED lamps
Line voltage selectors
Microprocessor manufacturers

page 6
8
13

About 60% of the tantalum capacitors used at Tek are dipped units, and these will have the largest price increase because the raw material is a larger percentage of the finished cost for these units. The cost increase will be large for the physically larger capacitors for the same reason. Our usage of tantalum foil and wet slug capacitors is small, but we will see price increases on these as well.

The following are price increases for some typical tantalum parts that we use in large quantities:

Part	Price		
	Feb. 78	May 79	Jun 79
1 μ F, 50V; dipped, case C	\$0.15	\$0.15	\$0.19
6.8 μ F, 35V; dipped, case D	0.13	0.15	0.21
100 μ F, 10V; dipped, case E	0.37	0.37	0.66
47 μ F, 25V; dipped, case E	0.72	0.60	1.19
100 μ F, 20V; dipped, case F	0.72	0.83	1.19
100 μ F, 20V; low ESR, axial lead	1.10	1.03	1.31

Case sizes for dipped parts:		
C 0.26" dia. x 0.36 H	E 0.40" dia. x 0.56 H	
D 0.34" dia. x 0.40 H	F 0.44" dia. x 0.68 H	

Because the demand for tantalum capacitors has outstripped the capacity of the manufacturers to produce them, chances are you may not be able to get the capacitors you can no longer afford! Lead times for some types of tantalum capacitors have stretched to 30 to 40 weeks, and several manufacturers are now allocating their production. Tektronix is a favored customer for most manufacturers and thus we should not see any major shortages of tantalum parts. If the predicted economic slowdown occurs, the demand for tantalum caps should ease, but until then the supplies will be very tight. Price increases are expected; unfortunately the timing and magnitude of these price hikes is anybody's guess.

Alternatives to tantalum capacitors

The best substitute for a dipped tantalum capacitor is a small, radial lead (single-ended) aluminum electrolytic capacitor. With proper selection you can find aluminum capacitors that will match most, but not all, of tantalum's characteristics, and they will cost less (sometimes up to a factor of ten less). The biggest difference between the two dielectric systems: the capacitance of aluminums is not as stable with time and temperature as tantalum caps.

continued on page 3

Figure 1
Hermetically sealed, axial lead tantalum capacitor

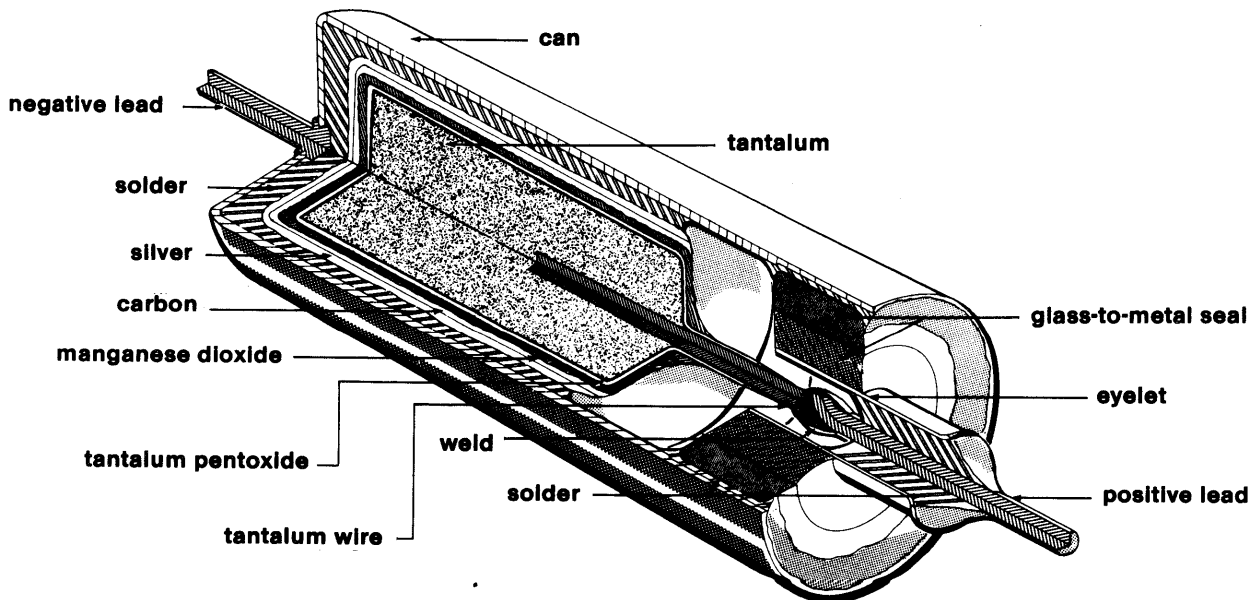
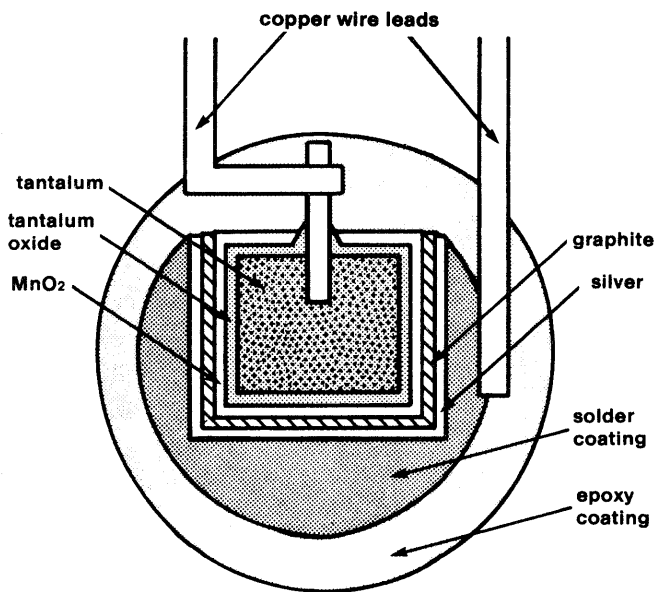
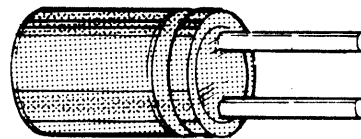

Figure 2
Dipped solid tantalum capacitor



Aluminum and Tantalum Capacitor Comparison

- 1. Capacitance stability** — Solid tantalum will vary -5% to $+5\%$ in the -40°C to $+85^{\circ}\text{C}$ temperature range and ΔC with life ranges between 0 and -4% . A typical aluminum will vary -20% to $+10\%$ between -40°C and $+85^{\circ}\text{C}$, and capacitance will slowly decrease with life.
- 2. Capacitance tolerance** — Tantalums are available in ± 20 , ± 10 and $\pm 5\%$ tolerance. Aluminums are available in $\pm 20\%$, with a very few available in $\pm 10\%$. The typical aluminum capacitor is -10% $+50\%$.
- 3. ESR** — The DF (dissipation factor, $\text{DF} = (\text{ESR}/X_C)$) of tantalums ranges between 5% and 10%, with the larger capacitance values having higher DF. The DF of aluminum ranges between 10% and 25%, although low ESR, non-aqueous electrolyte caps will have DFs that are the same or better than tantalum. Tantalums are better for high frequency bypassing because of their lower ESR and ESL (equivalent series inductance).
- 4. DC leakage** — DC leakage of tantalums is between $1\ \mu\text{A}$ and $20\ \mu\text{A}$, but their typical DC leakage is in the nanoamp range at room temperature. A low leakage aluminum will have leakage spec'd lower than the tantalum, but their typical DC leakage is not as low. A standard aluminum will have a leakage spec an order of magnitude higher than a tantalum.
- 5. Impedance at low temperatures** — A tantalum capacitor will show about a $+5\%$ impedance change at -40°C , and a typical aluminum will increase in impedance by a factor of three to six. Non-aqueous-electrolyte aluminums are almost as good as tantalums at low temperature.
- 6. Size** — Due to continuing improvements in the etching of aluminum foil and in packaging, it is now possible to buy Japanese-made aluminum electrolytics that are comparable in size with most tantalums. For a small CV product the tantalum part will be smaller, but for the larger CV products the aluminum cap may be smaller. Lead spacing is not exactly the same but is generally similar enough to be no problem.



Single-ended
(radial lead)
aluminum
capacitor

- 7. Life** — Dry tantalum capacitors have a very long life, although their most probable failure mode is a short circuit. The probability of failure increases if the capacitor is used in a low-impedance circuit where surge current is 0.3 amp or greater. If aluminum capacitors are adequately derated in voltage, ambient temperature and ripple current, they should have an operating life of ten years or greater. Dry tantalum capacitors have an almost indefinite shelf life, and aluminum capacitors should have a ten-year shelf life if they have DC leakage checked every three years, and are reformed when necessary.

continued on page 4

There are several families of aluminum capacitors that can be considered as replacements for tantalum capacitors. A number of Japanese manufacturers make tight tolerance, very low leakage, small aluminum electrolytic capacitors. Table 1 (page 5) is a copy of a representative data sheet from one of these manufacturers. There are other lines of capacitors that have a smaller size for the same CV product, or a lower ESR and higher ripple current capability.

Table 2 (below) compares two large dipped tantalum capacitors against four different lines of aluminum capacitors. The 290-0770-00 is a standard line of small, radial lead aluminum capacitors. The Z-series are designed to be tantalum replacements; the LS series is a new line of even smaller aluminum capacitors, and the 672D line is a non-aqueous-electrolyte aluminum capacitor designed for low ESR and high ripple current. It is available in can sizes up to 1" dia. x 3%" long

with very large CV products, and it is highly recommended for high ripple current, high frequency applications.

The aluminum electrolytic capacitor will successfully replace the dry tantalum capacitor in many applications with a very substantial cost savings.

For more information

If you have any questions about the tantalum price increase or some of the possible alternatives, please contact **Don Anderson (58-299), ext. 5415.**

continued on page 5

Table 2

Part	C	tol.	V	max. dia.	max. H	lead spacing	DF	DC leakage	ripple current	cost	
290-0721-00	100 μ F	± 20	20	.4"	.75"	.25"	10%	20 μ A	.34A	\$.80	tantalum
290-0519-00	100 μ F	± 20	20	.28 x .6	.8	.25	10%	20	.34A	1.15	tantalum
Z-series	100 μ F	± 20	25	.41	.65	.2	15%	6	.23A	.10	aluminum low leakage
290-0770-00	100 μ F	-10 +50	25	.41	.68	.2	17%	75	.23A	.07	aluminum
Panasonic LS	100 μ F	-10 +50	25	.33	.47	.14	15%	53	.23A	.07	aluminum small size
Sprague 672D	100 μ F	-10+100	25	.42	.83	.2	9.8%	45	.46A	.37	aluminum non-aqueous
290-0800-00	250 μ F	-10+100	20	.515	1.1	.2	5.5%	11	1.3A	.44	aluminum non-aqueous

Table 1

MINIATURE ALUMINUM ELECTROLYTICS

Z-SERIES

Specifications

Radial Lead Type

- Operating Temperature: -40 to +85°C
- Rated Working Voltage: 6.3 to 50VDC
- Rated Capacitance: 0.1 to 2200μF
- Capacitance Tolerance: ±20%

- Leakage Current: $I = 0.002CV + 1$ (μA) max.
Where, I : d-c leakage current (μA)
C : rated capacitance (μF)
V : d-c rated working voltage (V)
Leakage current shall be measured after 2-minute application of the rated d-c working voltage.

Dimensions: mm(inch)

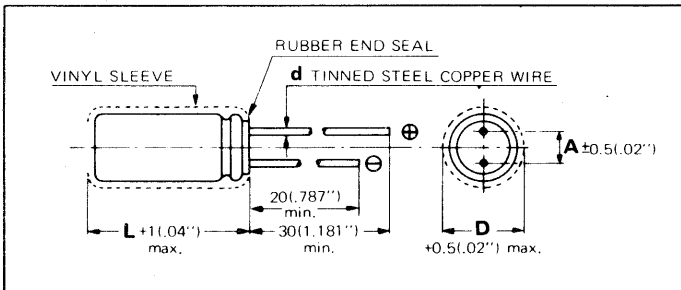

Body Dia. D	5 (.197)	6.3 (.248)	8 (.315)	10 (.394)	12.5 (.492)	16 (.630)	18 (.709)
Lead Dia. d	0.5 (.020)	0.6 (.024)	0.6 (.024)	0.6 (.024)	0.6 (.024)	0.8 (.032)	0.8 (.032)
Lead space, A	2 (.079)	2.5 (.098)	3.5 (.138)	5 (.197)	5 (.197)	7.5 (.295)	7.5 (.295)

■ Tan δ at 120 Hz:

WV DC	6.3	10	16	25	35	50	63	100
Tan δ	0.25	0.20	0.17	0.15	0.13	0.10	0.10	0.08

Ratings		Part Number	Dimensions : mm (inch)				Max. r-m-s Ripple Current (mA) @120Hz, 85°C	Max. Leakage Current (μA)
Voltage (V, DC)	Cap (μF)		D	L	A	d		
6.3	220	ECE-A6Z220	10.0(.394)	12.5(0.492)	5.0(.197)	0.6(.024)	250	3.7
	330	ECE-A6Z330	10.0(.394)	16 (0.630)	5.0(.197)	0.6(.024)	320	5.0
	470	ECE-A6Z470	10.0(.394)	21 (0.827)	5.0(.197)	0.6(.024)	380	6.7
	1000	ECE-A6Z102	12.5(.492)	26 (1.024)	5.0(.197)	0.6(.024)	530	13.0
	2200	ECE-A6Z222	16.0(.630)	26 (1.024)	7.5(.295)	0.8(.032)	800	27.4
10	22	ECE-A10Z22	5.0(.197)	11 (0.433)	2.0(.079)	0.5(.020)	60	1.5
	33	ECE-A10Z33	6.3(.248)	11 (0.433)	2.5(.098)	0.6(.024)	80	1.7
	47	ECE-A10Z47	6.3(.248)	11 (0.433)	2.5(.098)	0.6(.024)	100	1.9
	100	ECE-A10Z100	8.0(.315)	11 (0.433)	3.5(.138)	0.6(.024)	160	3.0
	220	ECE-A10Z220	10.0(.394)	16 (0.630)	5.0(.197)	0.6(.024)	250	5.4
	330	ECE-A10Z330	10.0(.394)	21 (0.827)	5.0(.197)	0.6(.024)	340	7.6
	470	ECE-A10Z470	12.5(.492)	21 (0.827)	5.0(.197)	0.6(.024)	400	10.4
	1000	ECE-A10Z102	12.5(.492)	26 (1.024)	5.0(.197)	0.6(.024)	580	21.0
	2200	ECE-A10Z222	16.0(.630)	33 (1.299)	7.5(.295)	0.8(.032)	850	45.0
16	6.8	ECE-A16Z6R8	5.0(.197)	11 (0.433)	2.0(.079)	0.5(.020)	30	1.3
	10	ECE-A16Z10	5.0(.197)	11 (0.433)	2.0(.079)	0.5(.020)	40	1.4
	22	ECE-A16Z22	6.3(.248)	11 (0.433)	2.5(.098)	0.6(.024)	70	1.7
	33	ECE-A16Z33	6.3(.248)	11 (0.433)	2.5(.098)	0.6(.024)	90	2.1
	47	ECE-A16Z47	8.0(.315)	11 (0.433)	3.5(.138)	0.6(.024)	110	2.5
	100	ECE-A16Z100	10.0(.394)	12.5(0.492)	5.0(.197)	0.6(.024)	220	4.2
	220	ECE-A16Z220	10.0(.394)	16 (0.630)	5.0(.197)	0.6(.024)	320	8.1
	330	ECE-A16Z330	10.0(.394)	21 (0.827)	5.0(.197)	0.6(.024)	405	11.6
	470	ECE-A16Z470	12.5(.492)	21 (0.827)	5.0(.197)	0.6(.024)	480	16.1
	1000	ECE-A16Z102	16.0(.630)	26 (1.024)	7.5(.295)	0.8(.032)	700	33.0
	2200	ECE-A16Z222	18.0(.709)	33 (1.299)	7.5(.295)	0.8(.032)	1000	71.4
25	3.3	ECE-A25Z3R3	5.0(.197)	11 (0.433)	2.0(.079)	0.5(.020)	20	1.2
	4.7	ECE-A25Z4R7	5.0(.197)	11 (0.433)	2.0(.079)	0.5(.020)	25	1.3
	6.8	ECE-A25Z6R8	6.3(.248)	11 (0.433)	2.5(.098)	0.6(.024)	35	1.4
	10	ECE-A25Z10	6.3(.248)	11 (0.433)	2.5(.098)	0.6(.024)	45	1.5
	22	ECE-A25Z22	8.0(.315)	11 (0.433)	3.5(.138)	0.6(.024)	80	2.1
	33	ECE-A25Z33	8.0(.315)	11 (0.433)	3.5(.138)	0.6(.024)	110	2.7
	47	ECE-A25Z47	10.0(.394)	12.5(0.492)	5.0(.197)	0.6(.024)	140	3.4
	100	ECE-A25Z100	10.0(.394)	16 (0.630)	5.0(.197)	0.6(.024)	230	6.0
	220	ECE-A25Z220	12.5(.492)	21 (0.827)	5.0(.197)	0.6(.024)	400	12.0
	330	ECE-A25Z330	12.5(.492)	26 (1.024)	5.0(.197)	0.6(.024)	500	17.5
	470	ECE-A25Z470	16.0(.630)	26 (1.024)	7.5(.295)	0.8(.032)	600	24.5
	1000	ECE-A25Z102	16.0(.630)	33 (1.299)	7.5(.295)	0.8(.032)	850	51.0
	50	0.1	ECE-A50ZR1	5.0(.197)	11 (0.433)	2.0(.079)	0.5(.020)	-
0.15		ECE-A50ZR15	5.0(.197)	11 (0.433)	2.0(.079)	0.5(.020)	-	1.1
0.22		ECE-A50ZR22	5.0(.197)	11 (0.433)	2.0(.079)	0.5(.020)	-	1.1
0.33		ECE-A50ZR33	5.0(.197)	11 (0.433)	2.0(.079)	0.5(.020)	-	1.1
0.47		ECE-A50ZR47	5.0(.197)	11 (0.433)	2.0(.079)	0.5(.020)	10	1.1
0.68		ECE-A50ZR68	5.0(.197)	11 (0.433)	2.0(.079)	0.5(.020)	10	1.1
1		ECE-A50Z1	5.0(.197)	11 (0.433)	2.0(.079)	0.5(.020)	10	1.1
1.5		ECE-A50Z1R5	5.0(.197)	11 (0.433)	2.0(.079)	0.5(.020)	10	1.2
2.2		ECE-A50Z2R2	5.0(.197)	11 (0.433)	2.0(.079)	0.5(.020)	18	1.3
3.3		ECE-A50Z3R3	5.0(.197)	11 (0.433)	2.0(.079)	0.5(.020)	25	1.4
4.7		ECE-A50Z4R7	6.3(.248)	11 (0.433)	2.5(.098)	0.6(.024)	35	1.5
6.8		ECE-A50Z6R8	8.0(.315)	11 (0.433)	3.5(.138)	0.6(.024)	45	1.7
10		ECE-A50Z10	8.0(.315)	11 (0.433)	3.5(.138)	0.6(.024)	60	2.0
22		ECE-A50Z22	10.0(.394)	12.5(0.492)	5.0(.197)	0.6(.024)	100	3.2
33		ECE-A50Z33	10.0(.394)	16 (0.630)	5.0(.197)	0.6(.024)	140	4.3
47		ECE-A50Z47	10.0(.394)	16 (0.630)	5.0(.197)	0.6(.024)	180	5.7
100		ECE-A50Z100	12.5(.492)	21 (0.827)	5.0(.197)	0.6(.024)	320	11.0
220		ECE-A50Z220	16.0(.630)	26 (1.024)	7.5(.295)	0.8(.032)	500	23.0
330		ECE-A50Z330	16.0(.630)	33 (1.299)	7.5(.295)	0.8(.032)	650	34.0
470		ECE-A50Z470	18.0(.709)	33 (1.299)	7.5(.295)	0.8(.032)	820	48.0

New LED lamps on the market

Several new styles of LEDs have recently been released. Most of them are interesting in shape — so interesting, in fact, that second sources are very difficult to find.

Most useful of these new displays are Monsanto's rectangular LEDs (Tek P/N 150-1070-00, red; 150-1073-00, yellow), which have evenly illuminated faces. The LEDs are available in two sizes — 0.125" x 0.220" suitable for backlighting legends, and 0.250" x 0.500" which has two LED chips in it rather than one. The smaller version is second-sourced by IEE.

Hewlett-Packard has countered with a "light-bar" series. These modules are also rectangular and come in a variety of sizes. Some of these are segmented (several rectangles connected end-to-end or side-to-side). HP also makes a rectangular LED with different construction than the light-bars which measures 0.100" x 0.285"

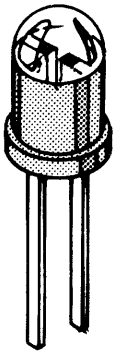

Monsanto LED
(note two chips)

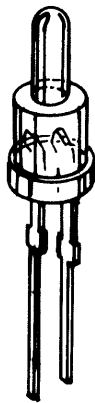

"Chimney" LED

Another introduction from Monsanto is an LED with two chips, one on the end of each post (lead), which are stitch-bonded in series. They are rated at 100 mA DC maximum current (when heat sunk) and specified at 40 mcd minimum at 100 mA. These LEDs appear very bright, but the two chips are clearly visible, as opposed to a diffused round spot of light. Stanley, Ltd. also offers LEDs specified at up to 80 mcd minimum at 20 mA. These are priced at 45¢ each in quantities of 1000, where Monsanto's parts sell for 75¢ each in similar quantities.

A four-digit stick display with digits about 1/4" tall has been released by Litronix. This display is interesting because it appears to be epoxy-filled (a more reliable type of construction), unlike most "sticks" presently available. Unfortunately, the pins come out of the part in a veritable forest. The display is designed for multiplexing.

Other interesting LED shapes we've seen recently include triangular parts, Debeso or "chimney" LEDs and round lamps with flat tops. Samples of most of the lamps mentioned here are available from Component Engineering. If you're interested in seeing them, or for more information, contact **Betty Lise Anderson (58-299), ext. 6389.**

Packaging Design moves to Merlo Road

The Packaging Design group recently moved to Merlo Road, delivery station 53-093. The telephone extensions for the group remain the same:

Mary Garcia	ext. 7615
Lane Gossett	ext. 6585
Jim Johnson	ext. 7615
Paul Phelps	ext. 6297

Please remember that there is no paging system in this building and it may be a little more difficult to reach us than in the past.

Lane Gossett, manager
Packaging Design

IC socket problem update

This is a follow-up article on the defective Texas Instruments C95 series sockets we received over a year ago. The C95 series face-grip sockets (see illustration) should **not** be used by any production areas.

The warehouse was purged of the C95 sockets several times last year, and to our knowledge the system is clear of them. Some of the trouble spots have been areas which over-schedule sockets and subsequently return them to stock for credit. Manufacturing Engineering has been inspecting all sockets returned to stock to help alleviate this problem. Other problems have arisen from farm-out areas and international operations because we have less visibility of these groups.

We have persuaded TI to mark the approved sockets with a scribed stripe on the top of the socket (see illustration). This marking is unique to the approved edge-grip socket and gives increased visibility to sockets already soldered into boards.

Insertion force with blunt IC leads is still a problem with this edge-grip socket, therefore soldering-in pretested ICs is still the recommended procedure for highest reliability (see **Component News 262**, pages 9-10 and **Component News 266**, pages 1-2).

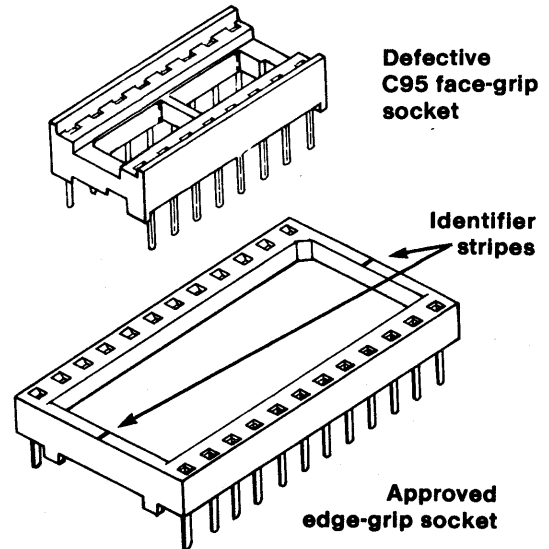

If you need further assistance please contact **Peter Butler (58-299), ext. 5417**.

Tubular ceramic variable capacitor availability

We have seven part numbers for tubular ceramic variable caps, and all were single-sourced to Mepco-Electra. Many months ago, Mepco said they would be discontinuing this style of capacitor, forcing Tek to use parts manufactured by Stettner Trush. Stettner's parts are very similar to the Mepco parts except the capacitance value on some part numbers is slightly different.

Since the qualification of Stettner Trush, Mepco has announced that they will resume production of four of the seven parts we use. (Mepco is resuming production because of customer protests.) The following list shows the new status for tubular ceramic variable caps.

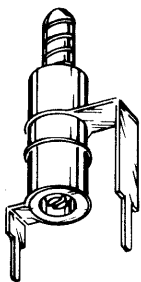

part number	sources?	C _{min}	C _{max}
281-0213-00*	2 sources	0.8	3.5
281-0214-00	2 sources	0.6	3.0
281-0215-00	1 source	1.2	10.0
281-0216-00	1 source	0.8	6.0
281-0217-00	1 source	0.6	3.5
281-0220-00	2 sources	1.0	5.0
281-0222-00	2 sources	1.0	6.0

*Stettner part is ≈ 0.075 " longer

If you need more information about the availability of these capacitors, contact **Alan LaValle (58-299), ext. 5415**.

Freon 12 freeze spray linked to ESD damage

Research by Murray Woods and Gary Gear, engineers at Intel, indicates that MOS IC devices in hermetic packages with non-conductive lids are damaged by freeze spraying with Freon 12 canned coolant. Freon 12 is used extensively for electronic troubleshooting and low-temperature testing.

Failure is induced by spraying the package lids with fresh cans of the coolant. Apparently only hermetically packaged parts with non-conductive lids are affected.

Damage occurs when positive charges from the freeze spray hitting the top of the lid induces a positive charge in the bottom of the insulating portion of the lid. The field produced in the air gap by this charge exceeds the breakdown strength of the air in the package. When breakdown occurs, positive and negative charges pass from die to lid causing circuit failure.

The method by which a positive charge is induced on the bottom of the lid by freeze spray is unknown. One possibility is that the combination of cold-induced stress and the positive charges from the Freon causes the lid to polarize.

Only fresh, fully-charged cans of Freon 12 cause failure. Strangely enough, cans with lower flow rates are negatively charged and do no damage!

Cooling alone is not a cause of the problem because dipping the packages in liquid nitrogen or freezing the lid top only in liquid nitrogen does not cause failures.

Failure can be prevented by grounding the bottom surface of the lid over the die, or by not subjecting these types of parts to Freon 12 freeze spray.

For additional information contact **Fred Fredricks, ext. 6890**, or refer to *IEEE Transactions on Electron Devices*, Vol ED-26, No. 1, Jan. 1979, pp. 16 - 21.

Dimension change on line voltage selectors

About a year ago, Switchcraft released a series of line voltage selectors which were designed to meet numerous safety requirements. We part-numbered four styles of this switch (see **Component News 261**, page 5), even though they were single-sourced. Now, Switchcraft has made major dimensional changes on the switch without any prior notification to Tektronix.

The dimension change affects the body height (from 0.551" to 0.690"), resulting in an overall height increase of 0.139". Although the part is still acceptable, this dimension change may cause problems in instruments where spacing is a concern.

Fortunately, we've found a replacement for the Switchcraft part which is better than the original. The switch is manufactured by Marquardt and is rated at 10A, 125V and 2A, 250V.

The chart below is a comparison of the two switches.

Tek P/N	Source	Mounting style/markings	Tek P/N	Comparable Replacement	
				Source	Mounting style/markings
260-1933-00	Switchcraft	Mounting tabs for panel mount; right angle PC terminals; marked 115/230			
260-1934-00	Switchcraft	Mounting tabs for panel mount; straight PC terminals; marked 115/230	→ 260-1967-00	Marquardt	Mounting tabs for panel mount; QC terminals; marked 115/230
260-1935-00	Switchcraft	No mounting tabs; straight PC terminals; marked Hi/Low	→ 260-1980-00	Marquardt	No mounting tabs; QC terminals; marked Hi/Low
260-1935-01	Switchcraft	No mounting tabs; straight PC terminals; marked 115/230	→ 260-1980-01	Marquardt	No mounting tabs; QC terminals; marked 115/230

Production areas report no problems soldering the "quick connect" (QC) terminals directly into boards. Also Marquardt should have a right-angle version of their switch available in January, 1980.

Please direct any questions concerning this switch to **Dennis Johnson (58-299), ext 5953**.

Joe Jonas
Electromechanical Component Engineering

TECHNICAL STANDARDS

The function of Technical Standards is to identify, describe, and document standard processes, procedures, and practices within the Tektronix complex, and to ensure these standards are consistent with established national and international standards. Technical Standards also provides a central repository for standards and specifications required at Tektronix.

Chuck Sullivan, manager (41-260)

use of component mounting details

Tektronix standards 062-1732-00 through -08 contain information on selecting and using mounting hole patterns. A definite cost savings for Tektronix derives from the ability to use existing patterns for new components when applicable, and to readily locate patterns for previously used part-numbered components.

To determine if a detail has been made for a known part number, consult standard 062-1732-00, where part numbers are in numerical order and detail numbers are identified. There is also a computerized listing by detail number, so applicable components can be identified.

Hole patterns are listed in the various suffix-numbered standards according to the number of holes in a pattern. When design requirements make it necessary to use a new detail, submit the part number of the component, along with a dimensioned and detailed sketch, to Technical Standards. A new detail number will be issued for use on drawings; as a result, a reproduction of the detail itself is required on the drawing (as explained in paragraph 2 of 062-1732-00).

Do not use arbitrarily-selected identifications (Detail "X," "Y," etc.) if a detail number exists. Pauline Whitmore, ext. 248, will be happy to provide assistance.

correction

In **Component News 272**, Component Standard: Reel Packaging of Axial Lead Components for Automatic Insertion, 062-3751-00, was identified as a replacement for 062-1688-00 and 062-1686-01. The correct numbers are 062-1686-00 and 062-1686-01.

new DOD standard

MIL-STD-100B was replaced by DOD-STD-100C, 22 Dec 78. The Department of Defense has announced that, whenever possible, it will use non-government documents which can satisfy military needs. DOD is also relating its drawing practices to an international standardization agreement with Great Britain, Canada, and Australia under the Quadripartite Standardization Agreement Army Standardization Agreement.

new standards available

ANSI/IEEE Std 260-1978 Letter Symbols for Units of Measurement

IEC 348 Safety Requirements for Electronic Measuring Apparatus 1978-Second Edition

IPC-TR-461 Final Task Group Report: Solderability Evaluation of Thick and Thin Fused Coatings

IPC-TR-468 Raw Materials Committee Report: Factors Affecting Insulation Resistance Performance of Printed Boards

IPC-TR-474 An Overview of Discrete Wiring Techniques

ISO/TC 95/SC 15 Proposal on Numeric and Alphanumeric Office Machines "Text Communication -- Function Symbols" (German Contribution)

NBS 440 COLOR: Universal Language and Dictionary of Names (U.S. Dept. of Commerce)

SAE HS J390 Society of Automotive Engineers Handbook Supplement -- Dual Dimensioning

continued on page 10

more TECHNICAL STANDARDS

revisions

For FCC Transmittal Sheet No. 10 to Vol. III of Rules and Regulations, August 1976 edition
 For UL 62, Eleventh Edition, Flexible Cord and Fixture Wire
 For UL 94, Second Edition, Tests for Flammability of Plastic Parts/Materials

military standards and specifications

DOD-STD-100C Engineering Drawing Practices, 1978 (Replaces MIL-STD-100B)
 MIL-STD-871A Electro-Chemical Stripping of Inorganic Finishes
 MIL-S-29180 Scaffolding Components, Steel (Tube and Coupler)
 MIL-T-49200 Test Set, Radio, AN/USM-306

Machine-Insertable Resistors

The Allen-Bradley 1/8 watt style BB carbon composition resistor (Tek P/N series 317-OXXX-00) is *not* machine-insertable. The resistor lead is only 0.015" in diameter, making it too flexible for automated insertion. The resistor lead is also too short for the sequencing equipment we use. A-B uses a miniature reel for this part.

The resistor series which can be machine inserted are 301, 302, 315, 316, 321, 322 and 323. Some of the 307 series are also machine-insertable, and are rated at 1/4 and 1/2 watt. Any part that is card-pack-only should not be used in a machine insertion application.

The 308 wirewound parts are machine-insertable if they meet the following requirements:

1. Round, tubular shaped body;
2. Axial leads;
3. Lead diameter at least 0.019" but not greater than 0.032". Board hole dimension is 0.035" nominal;
4. Body diameter does not exceed 0.250";
5. Body length does not exceed 0.675".

These requirements pertain to the 1/4, 1/2 and 3 watt sizes in the 308 series. However, you should note that some of the 1/2 and 1 watt sizes are too large for machine insertion.

The dolly index for the part numbers is on pages 0-8 and 0-9 of the November 1978 Resistor and Capacitor Parts Catalog. Three new dollies, all for 0.350" spacing, are now available. They are

D-206-1 Resistor, fixed, carbon, 1/8 watt 5% 10%
 D-227-1 Diode, D035 case
 D-389-1 Capacitor, fixed, small body

If you have any questions about which resistors can be machine inserted, contact **Ray Powell**, (58-299), ext. 6520.

ComponentNewsNewComponents

This column is designed to provide timely information regarding new components, vendors, availability and price. "New Components" can also be used as an informal update to the Common Design Parts Catalogs. Samples may or may not be available in Engineering Stock.

Vendor	No.	Description	When Available	P/N	Approx. Cost	Engineer to contact
analog devices						
Fairchild	2N4258	typePNP, dual, 400 MHz, 10V, 3pF	now	151-0467-00	\$.90	Matt Porter, 7461
National	92PU01A	NPN, TO-92 plus pkg., 40V, 2A, 50MHz	now	151-0710-00	.50	Matt Porter, 7461
National	92PU45A	NPN, TO-92 plus pkg., high current Darlington, 2A, 50V, 100MHz, HFE \approx 25K	Nov.	no P/N	.50	Matt Porter, 7461
National	LM1848	Demodulator, chroma, revised matrix output	now	156-1401-00	1.50	Matt Porter, 7461
RCA, Motorola, Plessey,	CA3046	Array, 5-transistor, selected for V_{CE} (sat) 10mA, 1mA 250mV max 25mA, 2.5mA 700mV max	now	156-0048-03	.80	Matt Porter, 7461
digital devices						
Rockwell, Synertek	6500 6500/EA	MOS μ P, 6500/1EAC emulator device, 14-pin DIP	now	156-1402-00	62.00	Carl Teale, 7148
electromechanical devices						
Littelfuse	3131012	Fuse, cartridge: 3 AG, 1.2A, 250V, slow blow: 25 sec.	Sept.	159-0158-00	.17	Dennis Johnson, 5953
GeneralElectric	C122B	SCR, 200V; 8A; TO-220 AB; high temp burn-in and screen	N/A	151-0521-01	N/A	Paul Johnson, 6365
optoelectronic devices						
Mallory	VPR	Capacitor, aluminum electrolytic, 800 μ F -10% +100%, 50V, low ESR, 4.8 amp ripple current, single-ended, 1" dia x 1 1/2"	Sept.	290-0901-00	1.52	Don Anderson, 5415
Mallory	VPR	Varistor, aluminum electrolytic, 1600 μ F -10% +100%, 50V, low ESR, 8.3A ripple current, single-ended 1" x 2 1/2"	Sept.	290-0900-00	1.75	Don Anderson, 5415
TRW	210	Capacitor, 0.06 μ F \pm 5%, 1000 VDC, metallized polypropylene	Sept.	285-1205-00	1.29	Don Anderson, 5415
Bourns	4308R101-471	Resistor, fixed film, SIP 8-7-470 Ω	now	307-0605-00	.39	Ray Powell, 6520
Bourns	4310R101-151	Resistor, fixed film, SIP 10-9-150 Ω	Oct.	no P/N	.39	Ray Powell, 6520
Clarostat	—	Resistor, variable, CP: 20K \pm 10%, linear rot. sw., SPDT w/detent, CCW; lug term	Nov.	311-2074-00	2.50	Gene Single, 5302
A-B, Clarostat	—	Resistor, model W, 382, variable, comp: 100 K Ω \pm 20%, linear, lug term	Nov.	no P/N	1.05	Gene Single, 5302

corrections

In **Component News 271**, under **analog devices**, a National Amplifier was listed as No. LF3520; the correct National number is LF352D. The Plessey comparator listed as SP9865 should be SP9685. The RCA transistor listed at \$100.00 should have been listed at \$1.00.

COMPONENT CHECKLIST

The "Component Checklist" is intended to draw attention to problems or changes that affect circuit design. This listing includes: catalog and spec changes or discrepancies; availability and price changes; production problems; design recommendations; and notification of when and how problems were solved. For those problems of a continuing nature, periodic reminders with additional details will be included as needed.

Tek P/N	Vendor	Description of part	Who to contact, ext.
none	Texas Instruments	GPIB controller	Jim Howe, 6303

Carl Hovey, TM500 Engineering, has uncovered another problem in the TI 9914 GPIB chip. It is possible for an unresolvable ambiguity to arise with respect to whether or not a particular output byte was actually accepted by the bus.

The 'BO' interrupt bit is set on entry into TACS whenever there is no byte in the data out register waiting to be sent (i.e., 'nba' is false). 'BO' is cleared by reading from the interrupt status register. It is possible to read and clear a 'BO' interrupt bit, and to then have the bit be set due to a sequence of Bus transitions, prior to writing to the data out register. There is a window of time from the time the interrupt status register is read until data is written to the data out register during which the chip is sensitive to the problem.

The problem is that if 'BO' is true when the write to the data out register occurs, then it is not possible to know whether the 'BO' is due to a byte having been sent or to some transition on the Bus prior to the write to the data out register.

Watching the handshake lines through the 9914 won't clear up the problem because of the case where ATN is true. In this case, the microprocessor will find 'BO' true and ATN true and will not be able to distinguish between two cases:

- a) the controller took control synchronously prior to the byte having been accepted,
- b) the controller took control after the byte was accepted.

Microprocessor Manufacturers

This chart outlines microprocessor manufacturers with the tradenames of microprocessors Tek emulates. Tek emulates the 8080, 6800, Z80, 9900, 8085, 3870 and F8. The 8001/8002A will support source and mask second source manufacturers.

	Intel	Rockwell	NEC	RCA	Motorola	Texas Inst.	Solid State Sci.	Hughes	Fairchild	National Semiconductor	Intersil	General Inst.	MOS Tech.	Mostek	Zilog	Signetics	Fujitsu	AMD	AMI	Synertek	Ferranti	Panasonic	Sharp	SMC	Hitachi
MN 1400																									
S2000																									
4004	■									▲															
4040	■																								
TMS 1000					▲																				
PPS-4		■																							
PPS-8		■																							
6500		●																							
6800					■				●				■												
6801					■				●																▲
6802					■				●																▲
6805					■																				
6809					■																				
SC/MP										■															
2650										●															
8008	■																								
8080	■				▲					▲															
8085	■				▲																				
9940					■																				
9980					■																				
Z8																									
Z80					▲																				
1802																									
1804																									
F8																									
3870																									
8048																									
9985																									
6100																									
1600																									
PACE																									
9900																									
8086																									
Z8000																									
F100L																									
MACS																									

■ SOURCE ● MASK SECOND SOURCE ▲ COPY SECOND SOURCE

Sealed trimmer caps prevent contamination

There is growing interest in purchasing ceramic trimmers in sealed or plastic cases. Probably the biggest advantage of a sealed trimmer (to Tek) is that it prevents the intrusion of solder flux and cleaning agents into the movable parts of the trimmer. Solder flux contamination continues to be a significant cause of plant failures, particularly when the trimmer is small or fragile.

Although the parts aren't hermetically sealed, the seal is good enough for the part to pass MIL-202E (106D), a ten-day humidity test. Some other benefits to be gained from these trimmers include:

- very sturdy construction and ease in handling,
- ability to retrofit many current applications (see lead spacing and case dimensions, below),
- very good electrical parameters,
- board runs could go under the trimmer (between the leads) without the concern of shorting to trimmer.

There are six standard values in this case size:

- 1.0 — 4.5 pF
- 2.5 — 10.0 pF
- 4 — 18 pF
- 5 — 25 pF
- 6 — 35 pF
- 7 — 40 pF

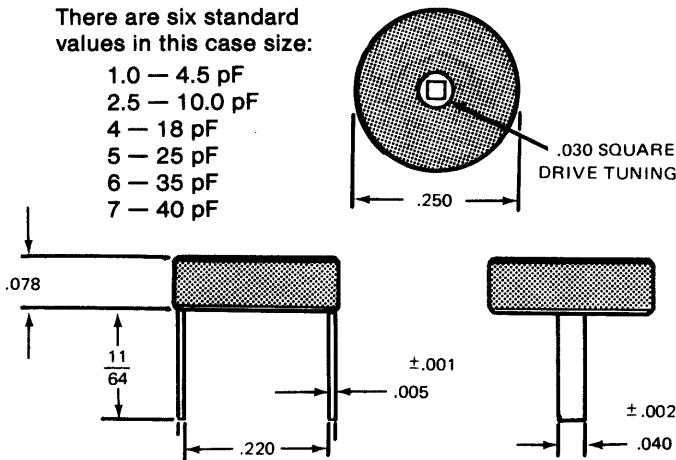

There are also two obvious disadvantages to these parts. They are square drive trimmers which would require special adjusting tools. In addition, there is currently only one source for the parts. The source is well-recognized and reliable, but we are discouraging sealed trimmer usage until there are at least two sources. A second source is progressing rapidly in the development of a sealed trimmer, so we should soon be able to recommend these parts for new design. Until then, I would appreciate any comments you might have concerning the acceptability of this type trimmer.

Alan LaValle
58-299, ext. 5415

More 062 ROM part numbers

There are two more ROM devices which have been assigned 062-XXXX-XX part numbers (see **Component News 272**, page 6 for details). If you have any questions about these parts, contact Bob Goetz (58-299), ext. 6302.

Part No.	Vendor No.	Manufacturer	Description
062-4170-00	SY2332	Synertek	S,T: M/C, DGTL; 4096 x 8 ROM, NMOS, 24-pin DIP. (CM)
062-4182-00	4732JL	TI	S,T: M/C, DGTL; 4096 x 8 ROM, NMOS, 24-pin DIP. (CM)

component news

Published by Technical Communications
58-299, ext. 6867

Jacque Calame, Editor
Birdie Dalrymple, Illustrator
Lola Janes, Writer

To submit an article, call Jacque on ext. 6867,
or stop by 58-299.

For mailing list changes, contact Kelly Turner at
19-123, ext. 5502.

COMPONENT NEWS

RICHARD DUNNFACE

92-701

company confidential