

INSTRUCTION MANUAL

MODIFICATION INSERT

Serial Number _____

7L12
MOD 139U

This insert is provided as a supplement to the instruction manual furnished with this modified instrument. The information given in this insert supersedes that given in the manual.

This insert material Copyright © 1973 by Tektronix, Inc., Beaverton, Oregon. Printed in the United States of America. All rights reserved. Contents of this insert may not be reproduced in any form without permission of the copyright owner.

U.S.A. and foreign Tektronix products covered by U.S. and foreign patents and/or patents pending.

7L12
MOD 139U

7L12
MOD 139U

This manual insert describes the features of MOD 139U as it applies to the 7L12 Spectrum Analyser plug-in unit. The input low-pass filter has been deleted and the center/start tuning range and the Max Span mode increased to 0 - 2.5 GHz. The Max Span mode has been changed from 180 to 250MHz/div, with center tuning changed from 900 to 1250 MHz.

CHARACTERISTICS

SPURIOUS RESPONSES. Because of the elimination of the input low-pass 1.8 GHz filter, certain spurious responses will be observed, as noted below:

1. IF FEEDTHROUGH. Untunable baseline lift in response to external 2.095 GHz input will be at least 25 dB below the response to a converted signal. Width of the response range will be determined by the RESOLUTION setting.
2. IMAGES. Image responses. (L.O. harmonics - 2 to 6 GHz input \approx 2.095 GHz, or 4.095 - 6.795 GHz input - L.O. \approx 2.095 GHz) are at least 10 dB below normal response.
3. INTERNAL SPURIOUS RESPONSES. For input signals 0 to 1.8 GHz, the limit is unchanged (-100 dBm). From 1.8 to 2.5 GHz, no greater than 60 dBm, principally at 2.2 GHz.

OTHER CHARACTERISTICS. Sensitivity, frequency tuning dial accuracy stability and incidental FM characteristics over the 0-2500 MHz range are within standard 7L12 limits for 0-1800 MHz. Flatness limits are increased from ± 1.5 to ± 2 dB over the 1800-2500 MHz range (only) referred to the 50 MHz response.

CALIBRATION

NOTE

The input low-pass filter has been deleted and the center/start tuning range and the Max Span mode is increased to 0 - 2.5 GHz.

Calibration is the same as standard except to adjust the 500 Ω pot (R1266 - located on added small circuit board which is mounted piggy-back on Sweep board) for 250 MHz/div when in Max Span mode.

PARTS LIST

Electrical

TRANSISTORS

Q1265	Add	151-1066-00	Silicon, FE, replaceable by P1086E
Q1270	Add	151-0190-00	Silicon, NPN, replaceable by 2N3904

7L12
MOD 139U

RESISTORS

R1265	Add	315-0102-00	1 k Ω , 1/4 W, 5%
R1266	Add	311-1261-00	500 Ω , Var, 1/2 W, 10%
R1268	Add	315-0103-00	10 k Ω , 1/4 W, 5%
R1269	Add	315-0203-00	20 k Ω , 1/4 W, 5%
R1270	Add	315-0333-00	33 k Ω , 1/4 W, 5%
R1272	Add	315-0104-00	100 k Ω , 1/4 W, 5%
R1440	Change	321-0345-00	38.3 k Ω , 1/8 W, 1%
R1447	Change	321-0160-00	453 Ω , 1/8 W, 1%

Mechanical

Max Spun Extender Circuit Board Assembly, film #M1119	Add	1	037-6198-00
Panel, front, film #7420-1	Change	1	034-0594-00
Filter, low-pass, 0 - 1.80 GHz	Delete	1	119-0294-00
Filter, low-pass, 0 - 2.5 GHz	Add	1	030-0899-02
Connector, terminal	Add	1	131-0589-00
Connector, terminal	Add	4	131-0591-00
Socket, terminal	Add	6	136-0252-04
Rotating Counter Assembly	Add	1	030-0900-02
Holder, terminal connector, 2-wire (black)	Add	1	352-0171-00

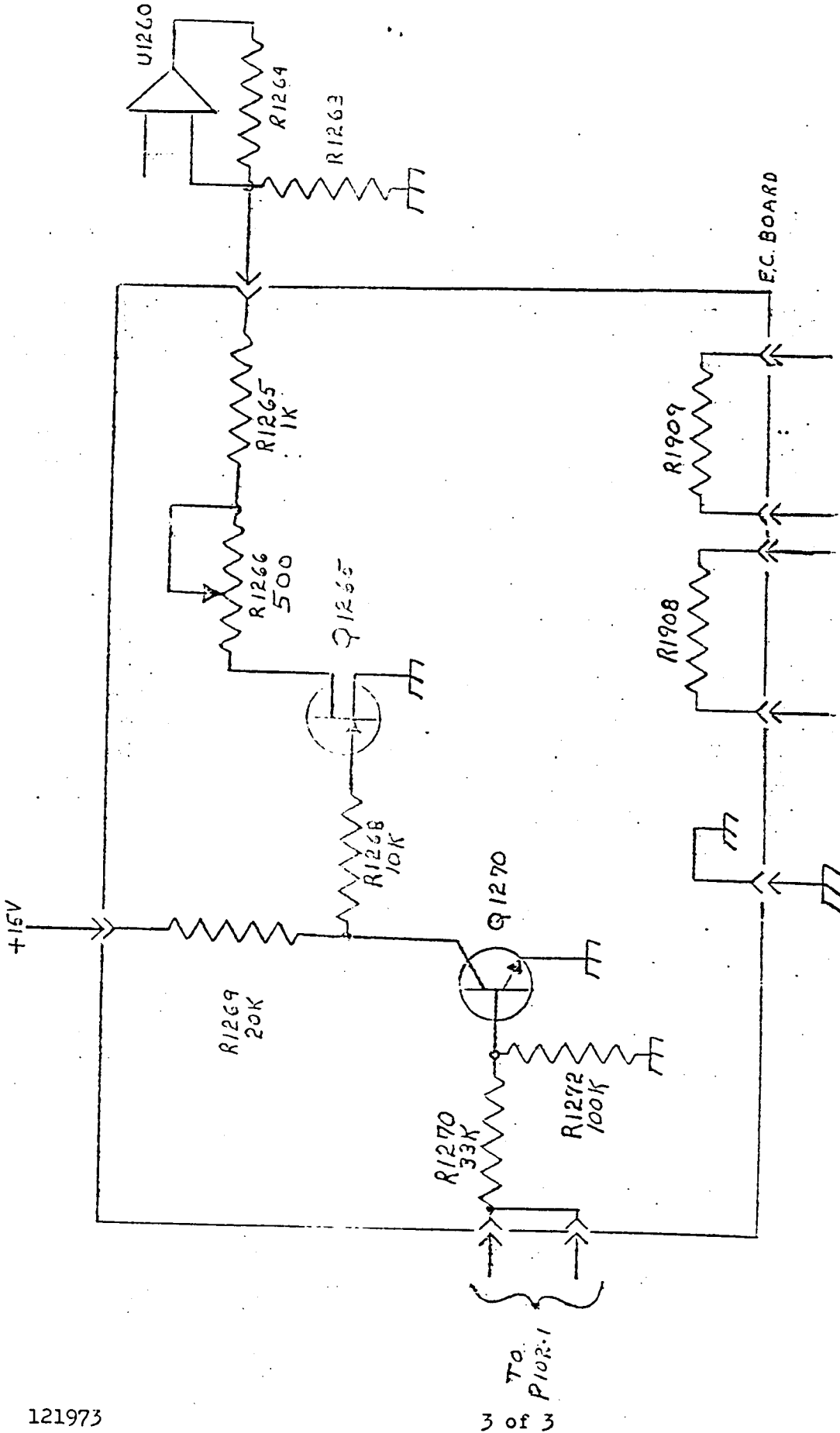

PART FREQ SPAN/DIV

9

CUSTOM MODIFICATION

INST 7L12 MOD 139U

BRIEF DESCRIPTION: Input filter deleted; tuning range and Max Span mode increased to 0 - 2500 MHz.

2850

PARTS LIST

EC Board Assembly Kit: (Max Span Extender).

<u>Qty</u>	<u>Part Number</u>	<u>Code</u>	<u>Description</u>
1	037-6198-00	1	EC Board film M1119, gold plate on .062 material.
1	131-0589-00		Connector terminal pin .406 long.
6	136-0252-04		Socket, terminal.
1	151-0190-00		Transistor, 2N3904.
1	151-1066-00		Transistor, FE, P1086E.
1	311-1261-00		Resistor, Var., 500 Ω , 1/2 W, 10 %.
1	315-0102-00		Resistor, Comp., 1 k, 1/4 W, 5 %.
1	315-0103-00		Resistor, Comp., 10 k, 1/4 W, 5 %.
1	315-0104-00		Resistor, Comp., 100 k, 1/4 W, 5 %.
1	315-0203-00		Resistor, Comp., 20 k, 1/4 W, 5 %.
1	315-0333-00		Resistor, Comp., 33 k, 1/4 W, 5 %.
1	321-0373-00		Resistor, prec., 75 k, 1/8 W, 1 %.
1	321-0402-00		Resistor, prec., 150 k, 1/8 W, 1 %.
1	352-0171-00		Holder, single-terminal, mini.

450

EC Board Wire Kit:

1	175-0731-00		2-1 #26 str. wire 2-1/2" long.
1	175-0733-00		0-N #26 str. wire 2-1/2" long.
1	175-0529-00		9-46 #26 str. wire 3" long.
1	175-0529-00		9-1 #26 str. wire 2-1/2" long with 131-0707-00 on one end.

Final Kit:

1	030-0899-02	2	Filter, low pass, 0 - 2.5 GHz.
1	030-0900-02	3	Counter Assy Rotating.
1	034-0594-00	4	Front Panel, film 7420-1, tooling as per 333-1459-01.
1	037-6198-00	1	EC board assembly (max span extender).
4	131-0591-00		Connector terminal pin .835 long.
1	321-0160-00		Resistor, prec., 453 Ω , 1/8 W, 1 %.
1	321-0345-00		Resistor, prec., 38.3 k, 1/8 W, 1 %.
1	334-1377-00		Label, ID adhesive-backed; marked; Mod 139U.

DATE
 PARTS LIST
 PAGE 1 OF 2
 REV.

CUSTOM MODIFICATION

INST 7L12 MOD 139U

Rebatch:

1	119-0294-00	Filter low pass 0 - 1.80 GHz.
1	333-1459-01	Front panel.

Code:

1. Order EC Board.
 - a. Order from Electro-Chem on a Job Request. Specify film number and gold plate on .062 material.
 - b. Assemble per Sample (see Build Procedure).
2. Order low-pass filter.
 - a. Obtain copy of assembly drawing from CME.
 - b. Coordinate order through Spectrum Analyzer Engineering Group.
3. Order the special Counter Rotating Assembly as follows:
 - a. Obtain copies of the following drawings from CME:
 - 030-0668-01
 - 030-0900-02
 - 030-0901-02
 - 030-0749-04
 - b. Send all drawing copies together with a Job Request, for part required, to Shop.
4. Order front panel.
 - a. Order from Electro-Chem on a Job Request. Specify film number and standard tooling.
5. Mark the ID label.
 - a. Use a typewriter with a carbon ribbon and type; 'Mod 139U' on the label.

APPROVED

DATE

PARIS LIST

PAGE 2 OF 2

REV

MODIFICATION

INST 7L12 MOD 139U

BUILD PROCEDURE: Assembly Outline: Assemble according to the standard procedure except to substitute the new low-pass filter and frequency counter control. The rest of the modification can be added to the completed unit.

1. Replace the Frequency Counter assembly with the special assembly 030-0900-02, from the kit.
2. Replace the 'Low-Pass' filter 119-0294-00 with the special Low-Pass filter from the kit (030-0899-02).
 - a. Due to the larger flange on each end, it will be impossible to slip the grommets and clamps over the filter as usual. It will be necessary to modify the clamp by removing a small 'wedge' of material and then 'cutting' the grommet, thus both can be fitted over the new filter.



3. Assembly the special EC board from the kit as follows:

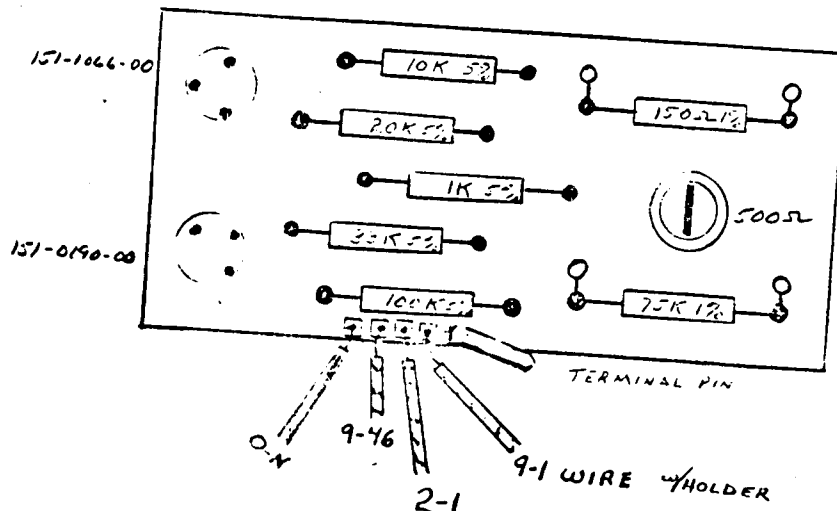

DATE

DATE 12-12-73

BUILD PROCEDURE

PAGE 1 OF 2

REV

CUSTOM MODIFICATION

INST 7L12 MOD 139U

4. Replace the 75 k 1/8 W 1 % resistor R1908, located just to the rear of P1032 on the Sweep EC board, with two long terminal pins, from the kit.
 - a. Solder a terminal pin in each of the resistor mounting holes.
5. Replace the 150 Ω 1/8 W 1 % resistor R1909, located just to the rear of P1032 on the Sweep EC board, with two long terminal pins, from the kit.
 - a. Solder a terminal pin in each of the resistor mounting holes.
6. Mount the special EC board assembly on top of the four terminal pins added to the Sweep EC board.
 - a. Position the special EC board assembly on the added terminal pins, with the two transistors toward the rear.
 - b. Solder the EC board to the terminal pins. (Solder to the top of the pins to provide maximum clearance underneath)
7. Unplug the single terminal holder, with the 9-1 wire, from P1021 of the Sweep EC board and then plug onto the single terminal pin, of the added EC board.
8. Plug the 9-1 wire with the single terminal holder, from the added EC board, onto the terminal pin of P1021.
9. Solder the 2-1 wire from the added EC board to the front solder pad (+15 V) of the 1.5 k 1/4 W 5 % resistor on the Sweep EC board (junction of R1155, R1156, and C1155). Pad is located directly under the new EC board.
10. Solder the 9-46 wire from the added EC board to the front solder pad for the 1.1 k 1/8 W 1 % resistor, on the Sweep EC board, located adjacent to P1037 at the rear of the added EC board (junction of R1264 and R1263).
11. Solder the 0-N wire from the added EC board to the solder pad, on the Sweep EC board, for the junction of pin 1, P1022 and the 0.1 μ F discap (GND).
12. Replace the 46.4 k, 1/8 W, 1 % resistor, R1440, located on the phase-lock EC board, with a 38.8 k 1/8 W 1 % resistor from the kit.
13. Replace the 750 Ω 1/8 W 1 % resistor from the kit. *? R1440*
14. Apply the adhesive-backed ID label marked; Mod 139U, on the lip of the upper left frame rail adjacent to the serial-number label.

This completes the modification.

Change to 38.3K

FORM

DATE

BUILD PROCEDURE

PAGE 2 OF 2

REV

CUSTOM MODIFICATION

INST 7L12 MOD 139U

CALIBRATION PROCEDURE: The Input Low Pass filter has been deleted and the center/start tuning range and the Max Span mode is increased to 0-2.5 GHz.

1. Calibration will be the same as standard except to adjust the added 500 Ω pot (R1266) for 250 MHz/div when in Max Span.

APP. #

DATE

CALIBRATION PROCEDURE

PAGE 1 OF 2

REV.

CUSTOM MODIFICATION

INST 7L12 MOD 139U

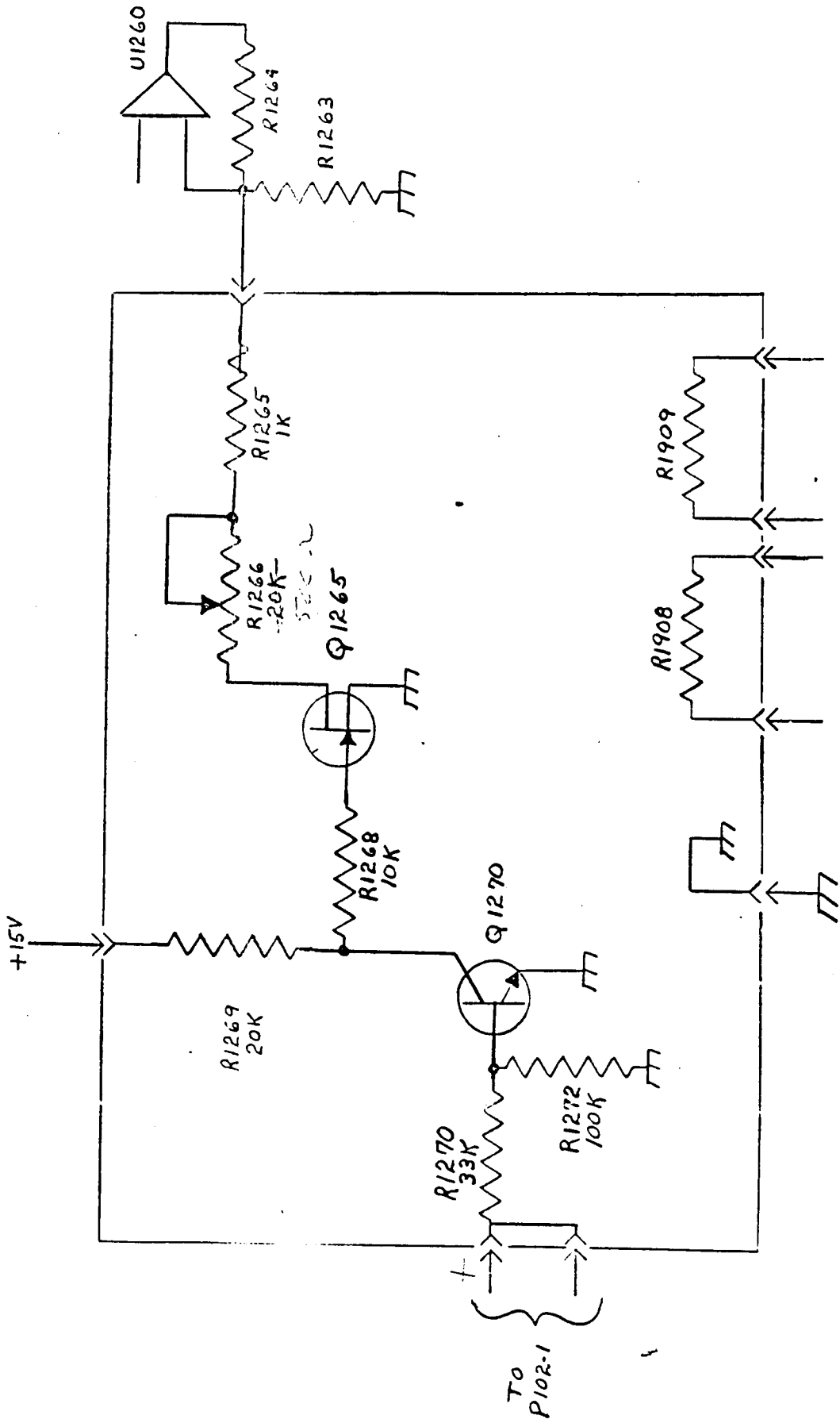

PART: FREQ SPAN/DIV

9

APPR. BY

DATE 12-12-73

CALIBRATION PROCEDURE

PAGE 2 OF 2 REV