

IIA34

Four Channel Amplifier

Service Reference



WARNING

The following servicing instructions are for use by qualified personnel only. To avoid personal injury, do not perform any servicing unless you are qualified to do so. Refer to the Safety Summary prior to performing any service.

Please check *for CHANGE INFORMA J/ON* at the rear of this manual.

TEK INTER-OFFICE COMMUNICATION

TO John Martin 94-540 DATE June 25, 1991
FROM Frank Gray, 50-PAT
SUBJECT GIDEP permit request

In response to the request to grant permission to the Government Industry Exchange Program (GIDEP) to reproduce Tektronix operator, service and instruction manuals, Tektronix, Inc. hereby grants such permission for distribution of such documents to any GIDEP user that is a full participant in the Metrology Data Interchange Data Base of GIDEP provided that all copies of the original work include the entire copyright notice and ownership statement exactly as it appears in the original, together with the Legend "Reproduced with permission."

This permission has been approved by the Intellectual Property Committee of Tektronix, and a copy of this memo may be provided to GIDEP to provide the requested permission.



Francis I. Gray
Group Patent Counsel

imp

INSTRUMENT SERIAL NUMBERS

Each instrument has a serial number on a panel insert, tag, or stamped on the chassis. The first number Or letter designates the country of manufacture. The **last** five digits of the Serial number ara assigned sequentially and are unique to each instrument. Those manufactured in the United **States have** six unique digits. The country of manufacture is identified as follows:

8000000	Tektronix, Inc. Beaverton , Oregon, USA
1000000	Tektronix Guernsey, Ltd., Channel Islands
2000000	Tektronix United Kingdom. Ltd., London
3000000	Sony/Tektronix , Japan
7000000	Tektronix Holland, NV, Heerenveen, The Netherlands

Copyright © Tektronix, Inc., 1987. All rights resewed. Tektronix products are covered by U.S. and foreign patents. issued and pending. TEKTRONIX, INC., SCOPEMOBILE and  are registered trademarks.

TEKPROBE® is a registered trademark of Tektronix, Inc.
Printed in U.S.A.

Contents

List of Illustrations	iii
List of Tables	iv
Safety Summary	v
Section I-General Information	
Introduction	1-1
Plug-in to Mainframe Compatibility	1-1
Initial Inspection	1-2
Installing and Removing the Plug-In	1-2
Instrument Options	1-3
Packaging for Shipment	1-4
Plug-In Memory Backup Power	1-4
Operating Environment	1-5
Operating Temperature	1-5
Section 2-Checks and Adjustments	
Using This Procedure	2-1
Menu Selections and Measurement Techniques	2-1
Plug-In Unit Installation and Removal	2-2
Initialized Setting	2-2
Test Equipment	2-2
Procedure Parts	2-2
Part 1-Initial Setup	2-5
Part 2a-Examine/Adjust Step Response: Standard Procedure	2-h
Examine Mainframe Step Response	2-7
Examine/Adjust Plug-In Step Response (A1R1027, A1R1029, A1R1041, A1R1043)	2-8
Part 2b-Examine/Adjust Srep Response: Alternative Procedure	2-10
Examine/Adjust Plug-In Step Response (A1R1027, A1R1029, A1R1041, A1R1043)	2-11
Part 3-Check Bandwidth	2-13
Part 4-Check Enhanced Accuracy	2-15
Part 5-Check DC Balance	2-17
Part 6-Check AV DC Accuracy	2-19
Part 7-Check DC Offset Accuracy	2-21
Section 3-Maintenance	
Preventive Maintenance	3-1
Plug-in Shield Removal	3-1
C l e a n i n g	3-1
E x t e r i o r	3-2
I n t e r i o r	3-2
Visual Inspection	3-2
Periodic Electrical Adjustment	3-2

Contents

Corrective Maintenance	3-3
Ordering Parts	3-3
Static-Sensitive Device Classification	3-3
Removing and Replacing FRUs	3-5
Semiconductor FRU Removal	3-7
Housekeeper Integrated Circuit ("Slam-Pack" ICs) ,	3-7
Amplifier Hybrids	3-g
EPROMIC	3-12
Processor IC	3-13
Circuit Board and Attenuator FRU Removal	3-15
Programming The Unit Identification	3-20
Multi-Pin Connectors	3-20
Troubleshooting	3-22
Diagnostic Troubleshooting	3-22
Diagnostics Overview	3-22
Kernel Diagnostics	3-22
Self Test/Extended Diagnostics	3-24
New Configuration Calibration	3-25
Field Replaceable Unit (FRU) Guide	3-25
Abbreviations of FRU Names	3-26
Abbreviations of Component and Module Names	3-26
Error Index Codes	3-26
Section 4-Theory of Operation	
Block Diagram Description	4-1
Signal Flow	4-1
Control Flow	4-3
Power	4-3
Section 5 -Replaceable Parts	
Change Information	
Related Documentation	
The Replaceable Parts section at the rear of this manual lists the Tektronix part numbers for all Standard Accessories provided with this product.	
Manuals (Standard Accessories)	
11A34 User's Reference Manual	
11A34 Incoming Inspection Procedure	

List of Illustrations

Figure 1-I.	Installing a plug-in in a mainframe oscilloscope .	1-3
Figure 2-1.	AI Main board adjustment locations.	2-9
Figure 3-I.	Field Replaceable Units (FRU) locator and AI Main board securing hardware .	3-6
	Semiconductor indexing diagram.	3-H
Figure 3-J.	Hypcon assembly removal and replacement.	3-10
Figure 3-K.	IC Insertion-Extraction Pliers.	3-14
Figure 3-L.	Location of screws and parts for removal of an attenuator.	3-17
Figure 3-M.	Location of a nut block securing the circuit board to the frame section .	3-18
Figure 3-N.	Indexing of multi-pin connectors.	3-21
Figure 3-O.	Sample LED fault code timing diagram.	3-23
Figure 4-1.	IIA34 Four-Channel Amplifier.	4-2

List of Tables

Table 2-1	Test Equipment	2-3
Table 2-2	11A34 Bandwidth Table	2-14
Table 2-3	11A34 DC Balance Table	2-18
Table 2-4	11A34 ΔV DC Accuracy Table	2-20
Table 2-5	11A34 DC Offset Accuracy Table	2-22
Table 3-1	Relative Susceptibility to Damage From Static Discharge	3-4

Safety Summary

The general safety information in **this** part of the summary is for both operating and servicing personnel. Specific warnings and cautions will be found throughout **the** manual **where** they apply, but may not appear in this summary.

Terms

In This Manual

CAUTION statements identify conditions or **practices** that could result in damage to the equipment or other property.

WARNING statements identify **conditions or** practices that could result in personal injury **or** loss of life.

As Marked on Equipment

CAUTION **indicates** personal injury hazard not immediately **accessible** as one reads the marking, or a hazard to property including the equipment itself.

DANGER **indicates** a personal **injury** hazard immediately **accessible** as one reads the marking.

Symbols

In This Manual



Static-Sensitive Devices,



This symbol indicates where **applicable** cautionary or other information is to be found.

As Marked on Equipment



DANGER-High Voltage.



Protective ground (earth) terminal.



ATTENTION- **refer** to manual.

Warnings

Power Source

This product is intended to operate in a mainframe connected to a **power source** that will not apply more than 250 V **rms** between **the** supply conductors or between either supply conductor and ground. A protective ground connection, by way of the grounding **conductor** in the mainframe power cord, is essential for safe operation.

Grounding the Product

This product is grounded through the grounding conductor of the mainframe power cord. To avoid electric shock, plug the mainframe power cord into a properly wired receptacle before connecting to the product input or output terminals. A **protective-ground** connection, by way of the grounding conductor in the mainframe power cord, is essential for safe operation.

Danger Arising from Loss of Ground

Upon loss of the protective-ground **connection**, all accessible conductive parts (including knobs and controls that may appear to be **insulating**), can render a" electric shock.

Do Not Operate in Explosive Atmospheres

To avoid explosion, do not operate this product in a" atmosphere of explosive gasses.

Do Not Service Alone

Do **not** perform internal service **or adjustment** of this product unless another person capable of rendering first aid and resuscitation is present.

Use Care When Servicing with Power On

Dangerous voltages exist **at** several points in this product. To avoid **personal** injury, do not touch **exposed** connections and components while power is on.

Disconnect power before removing protective panels, or replacing components.

Section 1

General Information

This section gives all the information needed to apply power to the 11A34 Four Channel Amplifier.

Information on installing and removing the plug-in, instrument options, packaging for shipment, as well as environmental conditions such as operating temperature and ventilation requirements is included here.

Introduction

This manual is designed for use by qualified service personnel. It contains information necessary to check, troubleshoot, and maintain the 11A34 Four Channel Amplifier. Troubleshooting is primarily based upon internal diagnostics. These diagnostics identify suspect FRUs (Field Replaceable Unit). Once the faulty FRU is identified, use the instructions provided in this manual to remove and replace it. Section 5, **Replaceable Parts** gives a complete list of the FRUs in this instrument.

The 11A34 plug-in is a four-channel, wide-bandwidth plug-in amplifier that plugs into any of the 11000-series plug-in mainframes. Commands from the mainframe control all the plug-in functions. The plug-in front panel has a momentary pushbutton and a back-lighted "display on" indicator for each input channel. Other controls and status indicators are located on the mainframe.

Input impedance of each channel is set independently to either 1 M Ω or 50 Ω . Bandwidth can be limited to 20 MHz or 100 MHz. Each channel provides a display and a trigger output to the host mainframe. Each of these outputs is comprised of any mainframe-specified combination of the input signals. The plug-in also provides an auxiliary output from each channel to the mainframe.

Each channel has a TEKPROBE[®] input connector. The TEKPROBE[®] input connector accepts a Level 1 or Level 2 TEKPROBE[®], a probe with a bnc connector, or a bnc connector. The plug-in detects the probe-encoding information and uses this information to automatically achieve the desired settings.

Plug-in to Mainframe Compatibility

The system bandwidth depends on the host mainframe. Details about bandwidth are included in Part 4. Specification, of the User's Reference Supplement, and in the Tektronix Corporate Catalog. Refer to the Tektronix Corporate Catalog for complete compatibility information.

Initial Inspection

This instrument was inspected mechanically and electrically before shipment. Therefore, the instrument should not have any marks or scratches and should meet all electrical specifications.

Inspect the plug-in for possible physical damage incurred in transit. Use the Incoming Inspection Procedure shipped with the instrument to verify instrument performance. If you find damage or deficiency, contact your local Tektronix Field Office or representative.

Installing and Removing the Plug-In

To install the plug-in in any 11000-series oscilloscope mainframe:

1. Set the mainframe ON/STANDBY switch to STANDBY to prevent damage to the instrument.

CAUTION

If the green indicator light remains ON when the STANDBY position is selected, then the switch has been left internally disabled after the servicing of the power supply. To enable the ON/STANDBY switch, refer to the Maintenance section of the mainframe Service Manual.

2. Align the grooves in the top and bottom of the plug-in with the guides in the mainframe plug-in compartment.
3. Insert the plug-in into the mainframe until its front panel is flush with the front panel of the mainframe.

To remove the plug-in from a mainframe.

1. Set the mainframe ON/STANDBY switch to STANDBY to prevent damage to the instrument.
2. Pull the release latch (see Fig. 1-1) to disengage the unit from the mainframe.
3. Pull the plug-in straight out of the plug-in compartment.

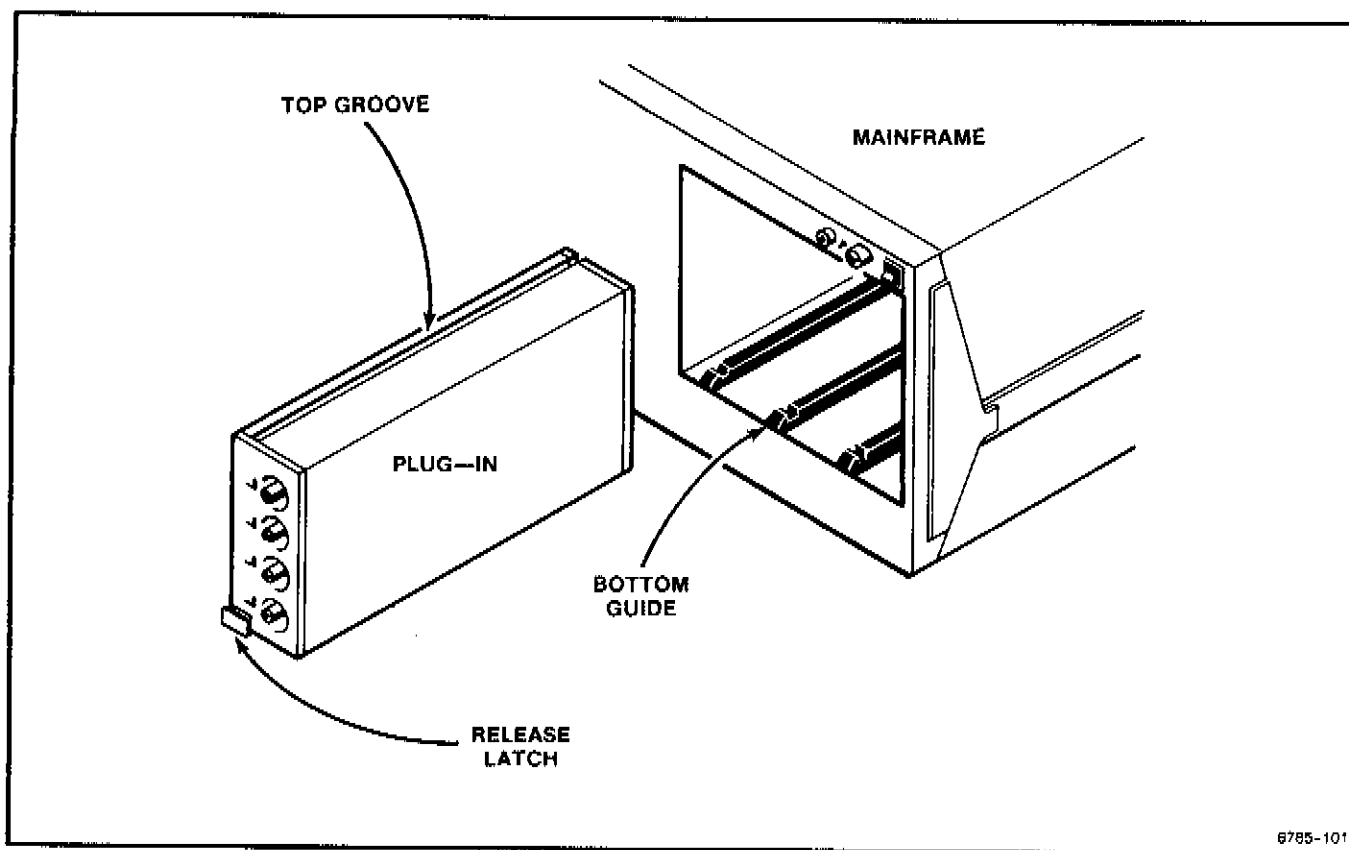

Figure 1-1. Installing a plug-in in a mainframe oscilloscope.

Instrument Options

The customer can order Option 23, which includes four P6134 probes.

Packaging for Shipment

If possible, save and reuse the original carton and packaging to package the instrument when shipping it by commercial transportation. Package and ship plug-in units and mainframes separately.

Attach a tag to the plug-in if it is shipped to a Tektronix Service Center for service or repair. Include the following information on the tag:

- Name and address of the instrument owner;
- Name of a person at your firm who can be contacted about the instrument;
- Complete instrument type and serial number; and
- A description of the service required.

Package the plug-in as follows, if the original package is not available or is not fit for use:

1. Obtain a corrugated cardboard carton with inside dimensions at least six inches greater than the instrument dimensions. Use a carton with a bursting test strength of at least 200 pounds per square inch.
2. Fully wrap the plug-in with anti-static sheeting, or its equivalent, to protect the finish.
3. Tightly pack dunnage or urethane foam between the carton and the instrument to cushion the plug-in on all sides. Allow three inches of packing on each side.
4. Seal the carton with shipping tape or with industrial staples.
5. Mark the address of the Tektronix Service Center and your return address on the carton in one or more prominent places.

Plug-In Memory Backup Power

The non-volatile RAM (A1U801 NV RAM) within the plug-in allows retention of the data in memory when the mainframe power is removed.

NV RAM stores system-configuration data such as the plug-in, mainframe, and probe IDs as well as the calibration constants. The data that the NV RAM stores, enable the plug-in to resume Enhanced Accuracy performance from a powered-down condition, without performing a full calibration (Enhanced Accuracy) operation.

The rated lifetime of the NV RAM's integral power source is ten years. If, on system power-up, the plug-in habitually loses Enhanced Accuracy status without a system configuration change (that is, the plug-in remains plugged into the same slot in the same mainframe), then the NV RAM might require replacement.

Operating Environment

The following environmental requirements are provided to ensure proper operation and long instrument life.

Operating Temperature

Operate the plug-in where the ambient air temperature is between 0° and +50° C. Store the plug-in unit in ambient temperatures from -40° to +75° C. After storage at temperatures outside the operating limits, allow the chassis to reach the operating temperature range before applying power.

Enhanced system accuracy is available after a 20-minute warmup period. After entry into Enhanced Accuracy, the instrument reverts to non-enhanced accuracy if the internal mainframe temperature changes more than 5° C.

Section 2

Checks and Adjustments

This section contains procedures to check electrical specifications and to manually set all internal adjustments. This procedure provides a logical sequence of check and adjustment steps, and is intended to return the instrument to specified operation following repair, or as a part of a routine maintenance program. Consult the User's Reference manual for more information about advertised specifications and instrument operation. Consult the test equipment manuals for information concerning test equipment setup or interconnection. The specifications or measurement limits are given at the beginning of each procedure.

Using This Procedure

In these procedures, capital letters within the body of text identify front-panel controls, indicators, and connectors (for example, MEASURE) on the mainframe and plug-in. Bold letters identify menu labels and display messages. Initial capital letters identify connectors, controls, and indicators (for example, Position) on associated test equipment. Initial capital letters also identify adjustments inside the plug-in (for example Vert Pos).

A heading system is used to readily identify the steps that contain performance verification and/or adjustment instructions. For example, if *CHECK* is the first word in the title of a step, an electrical specification is checked. If *ADJUST* appears in the title, the step involves an electrical adjustment. If *EXAMINE* is the first word in the step title, the step concerns measurement limits that indicate whether the instrument is operating properly; these limits are not to be interpreted as electrical specifications.

Menu Selections and Measurement Techniques

Details on measurement techniques and instructions for making menu selections are generally not included in this procedure. Comprehensive descriptions of menus and instrument features are located in the User's Reference manual.

The mainframe tutorial manual is strongly recommended to familiarize the first-time user with the mainframe controls and features.

Plug-In Unit Installation and Removal

CAUTION

To avoid instrument damage, set the mainframe ON/STANDBY switch to STANDBY before installing or removing plug-in units.

Initialized Setting

At the beginning of most steps, the user is instructed to Initialize the instrument as part of the setup. The Initialize feature, available through the Utility menu, presets all instrument controls and functions to known values. Initializing the instrument at the beginning of a step eliminates the possibility of settings from previous steps causing erroneous or confusing results. For more information on initialization, refer to the mainframe User's Reference manual.

Test Equipment

Table 2-1 contains suggested test equipment used with the Checks and Adjustment Procedure. Procedure steps are based on the test equipment examples given, but other equipment with similar specifications may be substituted. However, using other equipment could alter the test results, the setup information, or the related connectors and adapters required.

Procedure Parts

The procedure is divided into the following parts which should be performed sequentially:

1. Initial Setup
2. Examine/Adjust Step Response
3. Check Bandwidth
4. Check Enhanced Accuracy
5. Check DC Balance
6. Check ΔV DC Accuracy
7. Check DC Offset Accuracy

TABLE 2-1
Test Equipment

Description	Minimum Specification	Examples of Applicable Test Equipment
Power Module	Tektronix four-compartment power module.	TEKTRONIX TM 504 Power Module.
Leveled Sine Wave Generators	250 MHz to 1000 MHz, Leveled variable amplitude, 50 kHz or 6 MHz reference.	TEKTRONIX SG 504 Leveled Sine Wave Generator with a TM 500-series Power Module.
	250 kHz to 250 MHz, Leveled variable amplitude, 50 kHz reference.	TEKTRONIX SG 503 Leveled Sine Wave Generator with a TM 500-series Power Module.
Power Supply	Two supplies, continuously variable from 0-20 V; current limit, adjustable from 0-500 mA.	TEKTRONIX PS 503A Dual Power Supply with a TM 500-series Power Module.
Pulser	250 mV amplitude; ≤ 125 ps rise time; $< 1\%$ aberrations	TEKTRONIX 067-0681-01 Tunnel Diode Calibration Fixture.
Digital Voltmeter (w/test leads)	$\leq 0.01\%$ Accuracy.	Fluke 8842A Digital Voltmeter.
Signal Standardizer	Tektronix Calibration Fixture with interface connector modified for 11000-series use.	TEKTRONIX 067-0587-02 Signal Standardizer.
Calibration Generator	Period, 0.1 ms, Amplitude, -60 V.	TEKTRONIX PG 506 Calibration Generator with a TM 500-series Power Module.
Coaxial Cable (2 required)	50 Ω , 36-inch, male BNC connectors.	Tektronix Part 012-0482-00.
Adapter, BNC to Alligator Clips	BNC Female to clip leads.	Tektronix Part 013-0076-00.
Attenuator, 10X	Impedance: 50 Ω , one male and one female BNC connector	Tektronix Part 011-0059-02.
Adapter, BNC to Banana (2 required)	BNC Female to Dual Banana	Tektronix Part 103-0090-00.
Connector, T	BNC T: Two female and one male BNC connector.	Tektronix Part 103-0030-00.

TABLE 2-1 (cont)
Test Equipment

Description	Minimum Specification	Examples of Applicable Test Equipment
50 Ω Termination	Impedance: 50 Ω ; Accuracy, within 2%; connectors, BNC.	Tektronix Part 011-0049-01.
Resistor	510 Ω , 10% tolerance; power rating, 1 W.	Tektronix Part 303-0511-00.
Alignment Tool (insulated slot)	Insulated slot.	Tektronix Part 003-0675-01.
Magnetic Screwdriver	Holder for Torx tips.	Tektronix Part 003-0293-00.
Torx Screwdriver Tips	#6 tip #7 tip #8 tip #10 tip #15 tip	Tektronix Part 003-1415-00. Tektronix Part 003-1293-00. Tektronix Part 003-0964-00. Tektronix Part 003-0814-00. Tektronix Part 003-0966-00.
Integrated Circuit Extracting Tool	IC Insertion-Extraction Pliers 28-pin type	General Tool P/N U505BG or equiv.
Needle-nose pliers		
Tweezers		
Static Control Mat		Tektronix Part 006-3414-00.
Wrist Strap		Tektronix Part 006-3415-00.

Part 1 – Initial Setup

Description

Perform the Checks and Adjustment procedure within the ambient temperature range of +18° and +28° C, to assure proper instrument operation.

CAUTION

To avoid instrument damage, set the mainframe ON/STANDBY switch to STANDBY before installing or removing plug-in units.

Procedure

- a. Power on the following test equipment, so that it is warmed up with the instrument to be tested.
 - Power Supply
 - Calibration Generator
 - Leveled Sine Wave Generators
 - Digital Voltmeter
- b. With the ON/STANDBY switch set to STANDBY, connect the mainframe to a suitable power source.
- c. Install a Signal Standardizer in the Center plug-in compartment and the 11A34 in the Left plug-in compartment.
- d. Set the front-panel ON/STANDBY switch to ON.
- e. Allow the equipment to warm up for 20 minutes before continuing.

Part 2a – Examine/Adjust Step Response: Standard Procedure

Description

The Amplifier high frequency peaking is adjusted so that the bandwidth is adequate and that the aberrations are not excessive. The Standard Procedure requires the use of an 11402 mainframe to assure that the plug-in performs properly in any mainframe. If an 11402 mainframe is not available, use an 11401 to perform this procedure. If neither the 11401 nor 11402 mainframe is available, then use the Alternative Procedure at the end of this part.

First, the Signal Standardizer provides a reference waveform to characterize the mainframe. Mainframe aberrations are displayed at 2% per division.

Then, the waveform is compared with the characterizations of the waveform in the Examine Mainframe Step Response section to determine the plug-in's contribution.

Measurement Limits

The difference between the two waveform aberrations should not exceed 4.5% peak (2.25 divisions) and 7% (3.5 divisions) peak-to-peak. One major graticule division = 2%.

Examine Mainframe Step Response

Setup

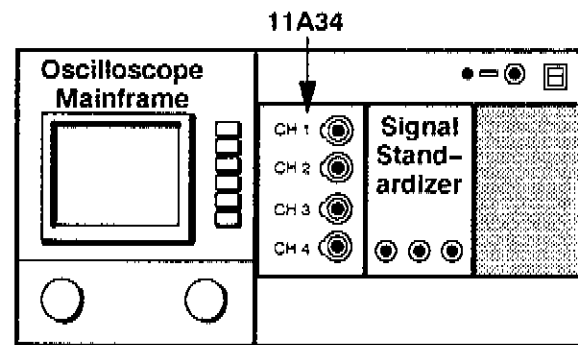

First Initialize the oscilloscope's settings, then perform the following in the order listed:

Oscilloscope Mainframe

Utility menu Instrument Options
 Waveform Scaling (Forced)
 Def Wfm C (center)
 Trigger menu Source Desc
 Main Trigger Source Description menu C (center)

Left Plug-In

Not used in this step.

Signal Standardizer

Test Vert or Horiz + Step Resp
 Rep Rate 100 kHz
 Position 12 o'clock
 Amplitude 9 o'clock

Oscilloscope Mainframe

Main Size 2 ns/div
 Trig Level 40%
 Main Pos position positive pulse transition
 one division from left edge of graticule

Acquire Description

Average N On
 Set Avg N 8

Signal Standardizer

Amplitude 5 div vertical step

Oscilloscope Mainframe

Vert Pos: Wfm position top of step on center
 horizontal graticule line
 Vert Mag: Wfm 100 mV

6785-205

Procedure

- Record the displayed waveform on graph paper or make a hardcopy of the display. This waveform is used in the following Examine/Adjust Plug-In Step Response procedure for comparison against the plug-in step response.
- Set the mainframe ON/STANDBY switch to STANDBY.
- Remove the Signal Standardizer from the Center plug-in compartment. Remove the 11A34 from the Left plug-in compartment.

Examine/Adjust Plug-In Step Response (A1R1027, A1R1029, A1R1041, A1R1043)

Setup

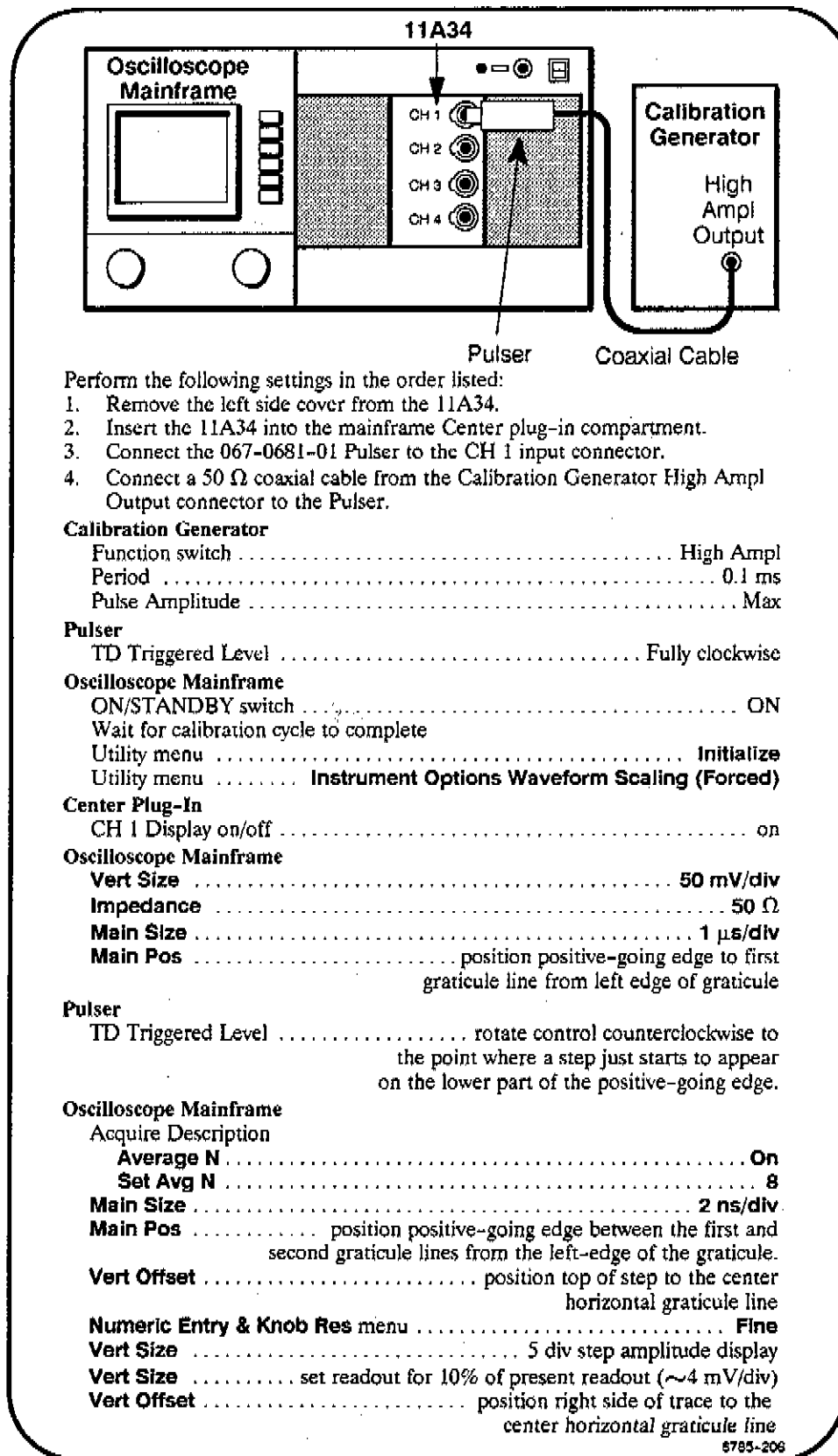

Perform the following settings in the order listed:

1. Remove the left side cover from the 11A34.
2. Insert the 11A34 into the mainframe Center plug-in compartment.
3. Connect the 067-0681-01 Pulser to the CH 1 input connector.
4. Connect a 50 Ω coaxial cable from the Calibration Generator High Ampl Output connector to the Pulser.

Calibration Generator

Function switch High Ampl
 Period 0.1 ms
 Pulse Amplitude Max

Pulser

TD Triggered Level Fully clockwise

Oscilloscope Mainframe

ON/STANDBY switch ON
 Wait for calibration cycle to complete
 Utility menu Initialize
 Utility menu Instrument Options Waveform Scaling (Forced)

Center Plug-In

CH 1 Display on/off on

Oscilloscope Mainframe

Vert Size 50 mV/div
 Impedance 50 Ω
 Main Size 1 μ s/div
 Main Pos position positive-going edge to first graticule line from left edge of graticule

Pulser

TD Triggered Level rotate control counterclockwise to the point where a step just starts to appear on the lower part of the positive-going edge.

Oscilloscope Mainframe

Acquire Description
 Average N On
 Set Avg N 8
 Main Size 2 ns/div
 Main Pos position positive-going edge between the first and second graticule lines from the left-edge of the graticule.
 Vert Offset position top of step to the center horizontal graticule line
 Numeric Entry & Knob Res menu Fine
 Vert Size 5 div step amplitude display
 Vert Size set readout for 10% of present readout (~ 4 mV/div)
 Vert Offset position right side of trace to the center horizontal graticule line

5785-206

Procedure

- a. **EXAMINE** – compare the displayed waveform with the waveform recorded in the previous Examine Mainframe Step Response procedure and examine the plug-in's contribution for aberrations within 4.5% peak (2.25 divisions) and 7% peak-to-peak (3.5 divisions).



DO NOT attempt to optimize the aberrations if they are within the stated limits. Proceed to step c.

- b. **ADJUST** – HF1, R1027 on the A1 Main board, so that the CH 1 aberrations are within 4.5% peak (2.25 divisions) and 7% peak-to-peak (3.5 divisions). Refer to Figure 2-1 for adjustment locations.
- c. Remove the displayed waveform.
- d. Move the Pulser to the CH 2 input connector. Then, repeat the Setup Procedure beginning at the Center Plug-In settings and proceeding through step a, b, and c in this procedure (the adjustment is performed using the HF2 adjustment, R1029).
- e. Move the Pulser to the CH 3 input connector. Then, repeat the Setup Procedure beginning at the Center Plug-In settings and proceeding through step a, b, and c in this procedure (the adjustment is performed using the HF3 adjustment, R1041).
- f. Move the Pulser to the CH 4 input connector. Then, repeat the Setup Procedure beginning at the Center Plug-In settings and proceeding through step a, b, and c in this procedure (the adjustment is performed using the HF4 adjustment, R1043).

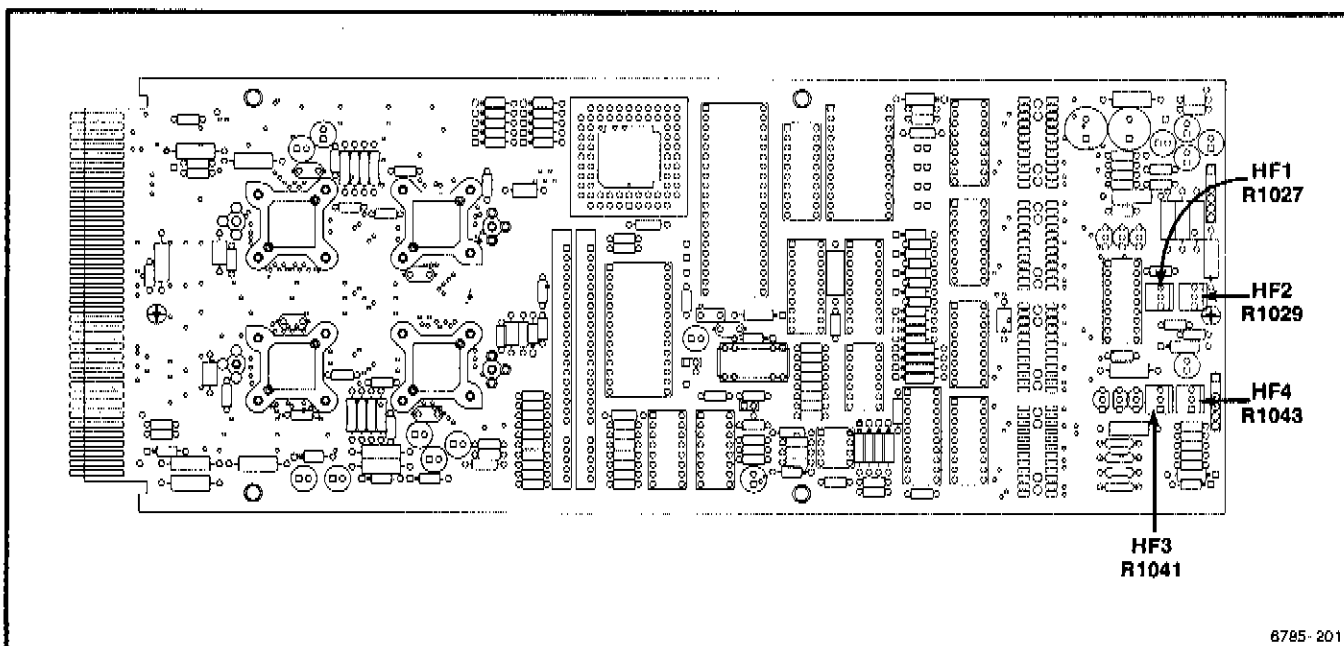

Figure 2-1. A1 Main board adjustment locations.

Part 2b – Examine/Adjust Step Response: Alternative Procedure

Description

The Amplifier high frequency peaking is adjusted so that the bandwidth is adequate and that the aberrations are not excessive. This procedure is used when neither the 11401 or the 11402 mainframe is available. Performance is assured only for the particular plug-in and mainframe combination examined and adjusted in this procedure.

Plug-in and mainframe aberrations are displayed at 20% per division.

Measurement Limits

The waveform aberrations should not exceed 4.5% peak (0.225 division) and 7% (0.35 division) peak-to-peak. One major graticule division = 20%.

Examine/Adjust Plug-In Step Response (A1R1027, A1R1029, A1R1041, A1R1043)

Setup

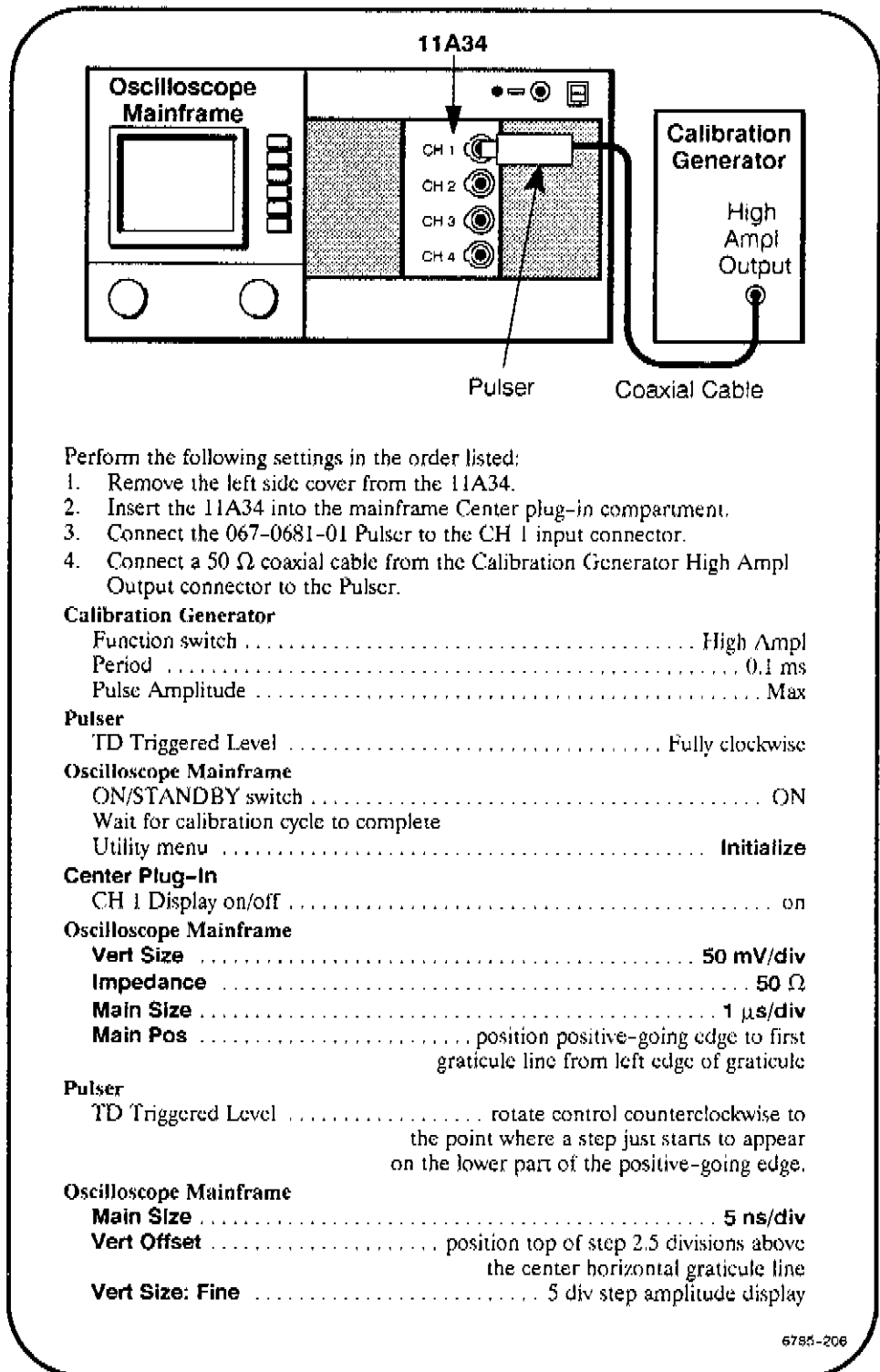

Perform the following settings in the order listed:

1. Remove the left side cover from the 11A34.
2. Insert the 11A34 into the mainframe Center plug-in compartment.
3. Connect the 067-0681-01 Pulsar to the CH 1 input connector.
4. Connect a 50 Ω coaxial cable from the Calibration Generator High Ampl Output connector to the Pulsar.

Calibration Generator

Function switch High Ampl
 Period 0.1 ms
 Pulse Amplitude Max

Pulsar

TD Triggered Level Fully clockwise

Oscilloscope Mainframe

ON/STANDBY switch ON
 Wait for calibration cycle to complete
 Utility menu Initialize

Center Plug-In

CH 1 Display on/off on

Oscilloscope Mainframe

Vert Size 50 mV/div
 Impedance 50 Ω
 Main Size 1 μ s/div
 Main Pos position positive-going edge to first
 graticule line from left edge of graticule

Pulsar

TD Triggered Level rotate control counterclockwise to
 the point where a step just starts to appear
 on the lower part of the positive-going edge.

Oscilloscope Mainframe

Main Size 5 ns/div
 Vert Offset position top of step 2.5 divisions above
 the center horizontal graticule line
 Vert Size: Fine 5 div step amplitude display

6785-206

Procedure

- a. **EXAMINE**—that the displayed waveform aberrations are less than 4.5% peak (0.225 division) and 7% peak-to-peak (0.35 division).



DO NOT attempt to optimize the aberrations if they are within the stated limits. Proceed to step c.

- b. **ADJUST**—HF1, R1027 on the A1 Main board, so that the CH 1 aberrations are within 4.5% peak (0.225 division) and 7% peak-to-peak (0.35 division). Refer to Figure 2-1 for adjustment locations.
- c. Remove the displayed waveform.
- d. Move the Pulser to the CH 2 input connector. Then repeat the Setup Procedure beginning at the Center Plug-In settings and proceeding through steps a, b, and c in this procedure (the adjustment is performed using the HF2 adjustment, R1029).
- e. Move the Pulser to the CH 3 input connector. Then repeat the Setup Procedure beginning at the Center Plug-In settings and proceeding through steps a, b, and c in this procedure (the adjustment is performed using the HF3 adjustment, R1041).
- f. Move the Pulser to the CH 4 input connector. Then repeat the Setup Procedure beginning at the Center Plug-In settings and proceeding through steps a, b, and c in this procedure (the adjustment is performed using the HF4 adjustment, R1043).

Part 3 – Check Bandwidth

Description

At 50 kHz the Leveled Sine Wave Generator amplitude is set for a displayed reference. The frequency is set to the specified bandwidth, and the displayed amplitude is checked for less than a 3 dB decrease.

Specified performance of the plug-in in all mainframes is assured only if the plug-in is tested in an 11402 mainframe. If the plug-in is tested in a mainframe of lower bandwidth, specified performance is assured only in mainframes of equal or lower bandwidth.

Specification

Refer to Table 2-2.

Setup

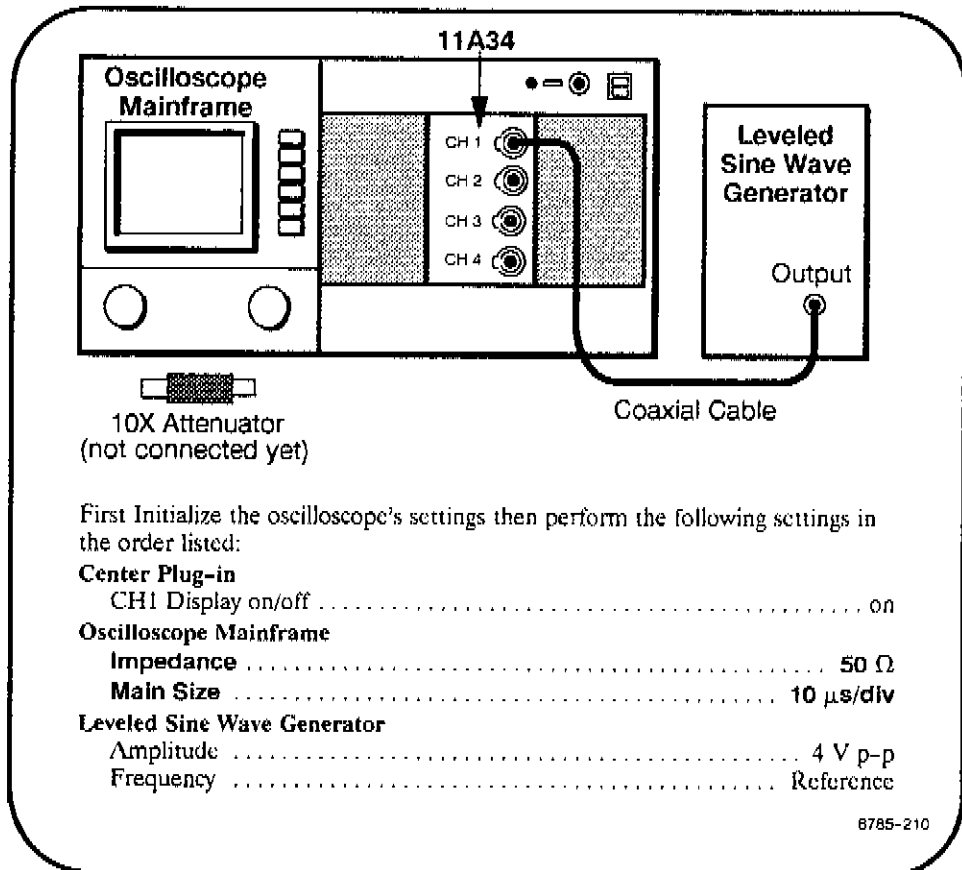

If the Leveled Sine Wave Generator has a remote leveling head, you must connect it to the plug-in input connector without additional coaxial cables.

The Reference frequency must be between 50 kHz and 6 Mhz.

Procedure

Perform this procedure for each Vertical Size listed in Table 2-2; then repeat for CH 2, CH 3, and CH 4.

This procedure may require the use of more than one Leveled Sine Wave Generator to test all the frequencies listed in Table 2-2.

If the Leveled Sine Wave Generator is not equipped with internal attenuators, then use two 10X Attenuators at the plug-in unit input when setting amplitude.

To measure the amplitude, either count the divisions, use the ΔV cursors, or use the peak-to-peak measurement function (11400 series mainframes only).

- a. Set the Leveled Sine Wave Generator amplitude as shown in the Reference Amplitude columns.
- b. Set the Leveled Sine Wave Generator frequency as shown in the Frequency column (according the mainframe type you are using).
- c. **CHECK**—that the displayed amplitude is at least the value shown in the CHECK Amplitude column.
- d. Set the Leveled Sine Wave Generator to the Reference frequency.
- e. Set Vertical Size as shown in the next line of Table 2-2.

TABLE 2-2
11A34 Bandwidth Table

Vertical Size V/div	Reference Amplitude		Frequency, MHz (Mainframe type:)				CHECK Amplitude	
	div	V	11402	11401	11302	11301	div	V
1	4	4	300	300	250	250	2.83	2.83
500 m	6	3	300	300	250	250	4.24	2.12
50 m	6	300 m	300	300	250	250	4.24	212 m
20 m	6	120 m	300	300	250	250	4.24	84.8 m
10 m	6	60 m	300	300	250	250	4.24	42.4 m
5 m	6	30 m	250	250	250	200	4.24	21.2 m
2 m	6	12 m	200	200	200	200	4.24	8.48 m
1 m	6	6 m	150	150	150	150	4.24	4.24 m

Part 4 – Check Enhanced Accuracy

Description

When displayed, the Enhanced Accuracy symbol (**EA**) indicates that the instrument is at its highest Accuracy state. The instrument saves the time of calibration and ambient temperature for use in maintaining the Enhanced Accuracy state.

For more information about the Enhanced Accuracy state, see Enhanced Measurement Accuracy Indicator in the mainframe User's Reference manual.

While Enhanced Accuracy is in effect, to verify the DC measurement Accuracy of the plug-in and mainframe system, apply and monitor test voltages, and compare these test voltages with the measurements made on the screen.

Specification

When invoked the self-calibration Activity executes successfully.

Setup

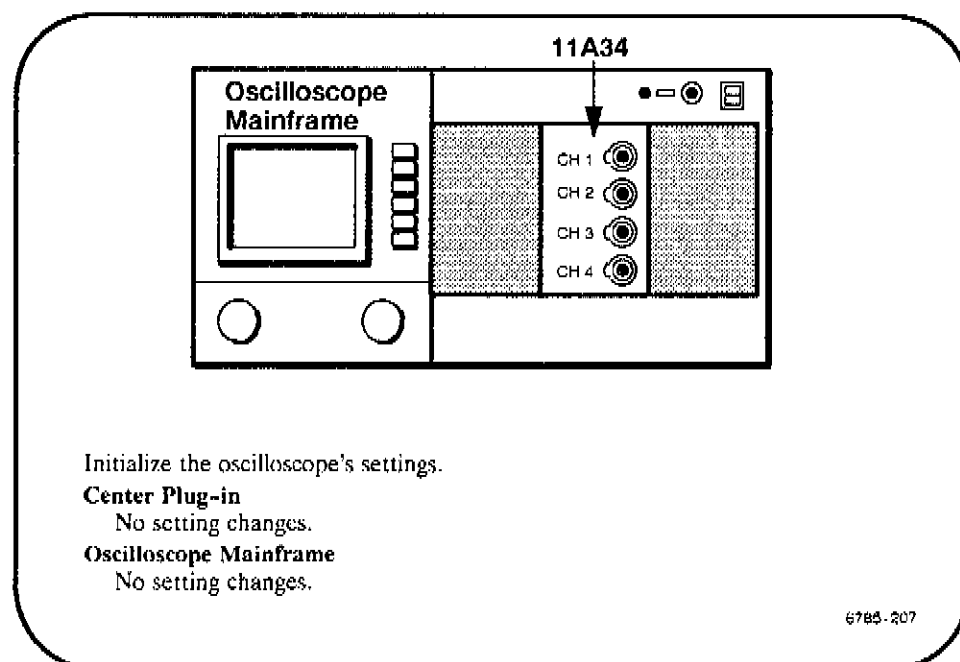

Procedure

- a. Twenty minutes after power up, the instrument must recalibrate itself to achieve the Enhanced Accuracy state. Press the ENHANCED ACCURACY button. Another prompt then appears on the display. Press the ENHANCED ACCURACY button again. Self-calibration takes a couple of minutes.

CAUTION

Turning the instrument power off during self-calibration may result in losing some of the Non-Volatile RAM data. This could cause diagnostic errors at the next power-up and affect normal instrument operation in unpredictable ways.

- b. **CHECK**—for the message, “**Calibration in Progress**” or “**Enhanced Accuracy in Progress**”, indicating that the instrument began self-calibration.
- c. **CHECK**—for the message, “**Calibration completed and passed**” or “**Self Calibration completed successfully**”, indicating successful self-calibration. The EA indicator appears on the display when calibration is finished.

Part 5 – Check DC Balance

Description

The position of the displayed trace with no input signal applied is examined.
The system must be in Enhanced Accuracy mode during this procedure.

Specification

Refer to Table 2-3.

Setup

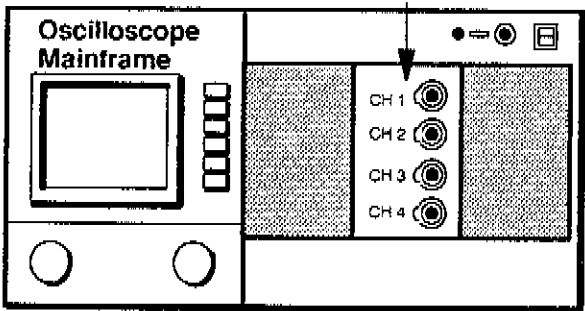

11A34

Oscilloscope Mainframe

CH 1
CH 2
CH 3
CH 4

First Initialize the oscilloscope's settings then perform the following settings in the order listed.

Center Plug-in
CH 1 Display on/off on

Oscilloscope Mainframe
Vert Size 10 V/div
BW Limit or HF Limit 20 MHz
Impedance 50 Ω

6765-207

Procedure

Perform this procedure for each channel.

CHECK— that the displayed trace position is at the center graticule line, within the value Shift listed in Table 2-3 for each Vert Size setting.

If you are using the 11301 or 11302 mainframe, use **Vertical cursors** to help measure the trace position.

If you are using the 11401 or 11402 mainframe, set **Average N** to **ON** and use **Mean (whole zone)** in the Measurement menu to help measure the trace position.

TABLE 2-3
11A34 DC Balance Table

Vert Size	1140L, 11402 Shift		11301, 11302 Shift (\pm div)
	(\pm div)	(\pm mV)	
10 V/div	0.063	630	0.093
5 V/div	0.065	330	0.095
2 V/div	0.073	146	0.103
1 V/div	0.085	85	0.115
0.5 V/div	0.065	33	0.095
0.2 V/div	0.073	14.6	0.103
0.1 V/div	0.085	8.3	0.115
50 mV/div	0.065	3.3	0.095
20 mV/div	0.073	1.46	0.103
10 mV/div	0.085	.83	0.115
5 mV/div	0.110	.55	0.140
2 mV/div	0.185	.37	0.215
1 mV/div	0.310	.31	0.340

Part 6 – Check ΔV DC Accuracy

Description

The system ΔV DC Accuracy is checked using a precision Digital Voltmeter and a Power Supply.

The system must be in Enhanced Accuracy mode during this procedure.

Specification

Refer to Table 2-4.

Setup

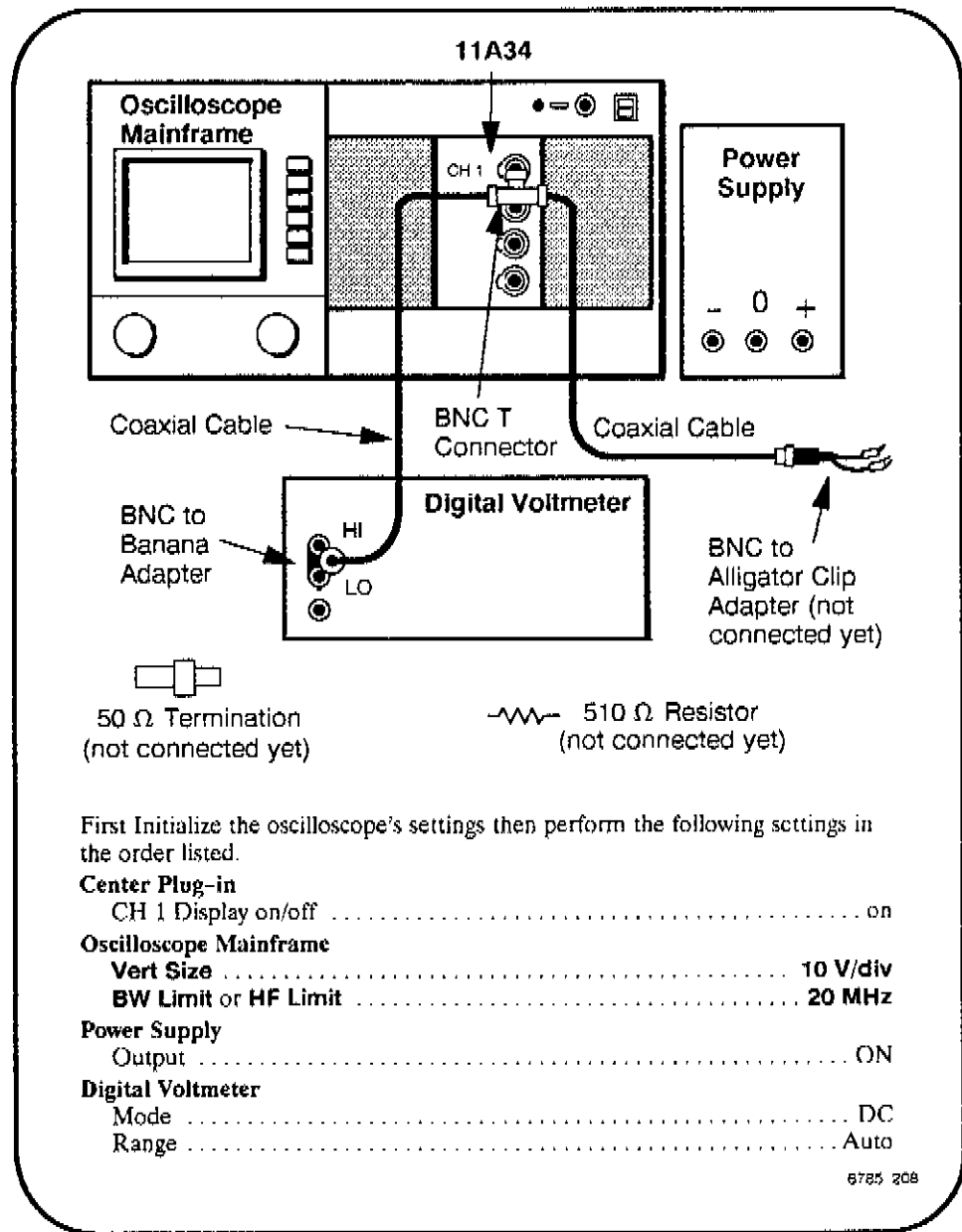

Procedure

Perform this procedure for each channel.

- a. If you use the 11301 or 11302 mainframe, then select **Vertical Cursors** and position the cursors for readouts of $\text{Vert Ref} = -30.0 \text{ V}$ and $\Delta\text{Vert} = 60.0 \text{ V}$.
If you use the 11401 or 11402 mainframe, then set **Average N** to **ON** and use **Mean (whole zone)** in the Measurements menu to help set the trace to the graticule marks.
- b. Connect the alligator clips to the Power Supply and set the voltage so that the trace is coincident with the 11301/11302 cursor at -3 divisions or the 11401/11402's fourth graticule mark below the center of the screen. Read the Digital Voltmeter (DVM) and record this value (V_1) on a copy of Table 2-4.
- c. Connect the alligator clips to the Power Supply and set the voltage so that the trace is coincident with the 11301/11302 cursor at $+3$ divisions or the 11401/11402's fourth graticule mark above the center of the screen. Read the DVM and record this value (V_2) on a copy of Table 2-4.
- d. Subtract $V_2 - V_1 = \Delta V$ and write the absolute value of the difference on the copy of Table 2-4.
- e. **CHECK**—that ΔV is within the tolerance given in the specification column of Table 2-4.
- f. **CHECK**—each **Vert Size** setting listed in Table 2-4 by repeating steps b through e. Set the **Vert Size** as directed. When testing with small voltages, it may help to install a resistor in series and a 50Ω termination in parallel between the power supply output and the coaxial cable so that you can set the voltages with better resolution.

NO CHARACTERIZATION FACTOR

TABLE 2-4
11A34 ΔV DC Accuracy Table

6390 1.2%

Vertical Size	Voltmeter Readings			Specification Limit	
	V_1 (from step b)	V_2 (from step c)	$\Delta V = V_2 - V_1 $ (from step d)	11401/11402 (ΔV)	11301/11302 (ΔV)
10 V/div	___ V	___ V	___ V	$80 \pm 0.504 \text{ V}$	$60 \pm 0.720 \text{ V}$
5 V/div	___ V	___ V	___ V	$40 \pm 0.252 \text{ V}$	$30 \pm 0.360 \text{ V}$
2 V/div	___ V	___ V	___ V	$16 \pm 0.101 \text{ V}$	$12 \pm 0.144 \text{ V}$
1 V/div	___ V	___ V	___ V	$8 \pm 0.0504 \text{ V}$	$6 \pm 0.720 \text{ V}$
0.5 V/div	___ V	___ V	___ V	$4 \pm 0.0252 \text{ V}$	$3 \pm 0.0360 \text{ V}$
0.2 V/div	___ mV	___ mV	___ mV	$1.6 \pm 0.0101 \text{ V}$	$1.2 \pm 0.0144 \text{ V}$
0.1 V/div	___ mV	___ mV	___ mV	$800 \pm 5.04 \text{ mV}$	$600 \pm 7.20 \text{ mV}$
50 mV/div	___ mV	___ mV	___ mV	$400 \pm 2.52 \text{ mV}$	$300 \pm 3.60 \text{ mV}$
49 mV/div	___ mV	___ mV	___ mV	$392 \pm 2.47 \text{ mV}$	$294 \pm 3.53 \text{ mV}$
23 mV/div	___ mV	___ mV	___ mV	$184 \pm 1.16 \text{ mV}$	$138 \pm 1.66 \text{ mV}$
20 mV/div	___ mV	___ mV	___ mV	$160 \pm 1.01 \text{ mV}$	$120 \pm 1.44 \text{ mV}$
10 mV/div	___ mV	___ mV	___ mV	$80 \pm .504 \text{ mV}$	$60 \pm 0.720 \text{ mV}$
5 mV/div	___ mV	___ mV	___ mV	$40 \pm 0.252 \text{ mV}$	$30 \pm 0.360 \text{ mV}$
2 mV/div	___ mV	___ mV	___ mV	$16 \pm 0.101 \text{ mV}$	$12 \pm 0.144 \text{ mV}$
1 mV/div	___ mV	___ mV	___ mV	$8 \pm 0.0504 \text{ mV}$	$6 \pm 0.0720 \text{ mV}$

Part 7 – Check DC Offset Accuracy

Description

The system DC Offset is checked using a precision Digital Voltmeter and a Power Supply.

The system must be in Enhanced Accuracy mode during this procedure.

Specification

Refer to Table 2-5.

Setup

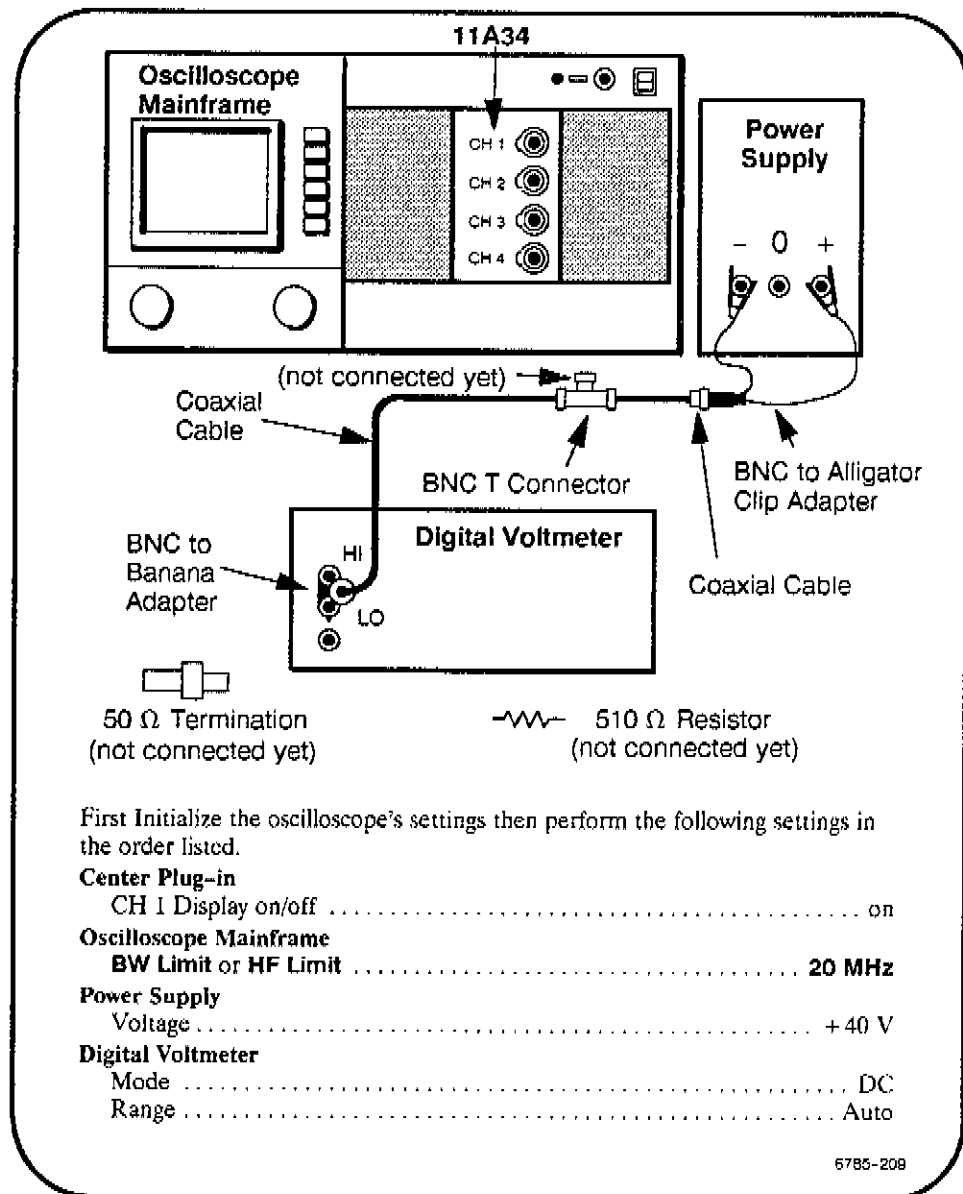

Procedure

Perform this procedure for each channel.

- a. Note the position of the displayed trace (it should be near the center of the graticule).
 If you are using the 11301 or 11302 mainframe, use **Vertical Cursors** to help measure and set the trace position.
 If you are using the 11401 or 11402 mainframe, set **Average N** to **ON** and use **Mean (whole zone)** in the Measurement menu to help measure and set the trace position.
- b. Connect the BNC T Connector to the CH 1 input connector, with the DVM connected.
- c. Set the **Vert Offset** to **40 V**. Connect the alligator clips to the Power Supply and set the voltage so that the displayed trace returns to the position noted in step a.
- d. **CHECK**—that the difference between the Vert Offset reading and the DVM reading is less than that shown in Table 2-5.
- e. Disconnect the Power Supply and set **Vert Offset** to **0**.
- f. Repeat steps a through e for each Vert Size and Offset shown in Table 2-5. When testing with small voltages, it may help to install a resistor in series and a 50 Ω termination in parallel between the power supply output and the coaxial cable so that you can set the voltages with better resolution.

TABLE 2-5
11A34 DC Offset Accuracy Table

Vertical Size	Vertical Offset	(Vertical Offset - DVM Reading) Limit (± Volts)
$\pm(0.25^{90}) + 50\text{ mV}$ 1 V/div	40 V	124 mV 50
$\pm(0.25^{90}) + 5\text{ mV}$ 0.1 V/div	10 V	24 mV
1 mV/div	1 V	2.0 mV
$\pm(0.20^{90}) + 5\text{ mV}$ 1 mV/div	800 mV	1.7 mV
1 mV/div	600 mV	1.4 mV
1 mV/div	400 mV	1.1 mV
1 mV/div	200 mV	0.8 mV

Section 3

Maintenance

This section contains information for performing preventive maintenance, corrective maintenance, testing and diagnostics. All support-related items mentioned in this manual are listed in Table 2-1.

Preventive Maintenance

Preventive maintenance performed regularly can prevent or forestall instrument breakdown and may improve instrument reliability. The severity of the environment to which the instrument is subjected determines the frequency of maintenance.

Plug-in Shield Removal

The side shields, top-and-bottom frames, and front panel reduce radiation of electromagnetic interference (EMI) from the instrument. The side shields are held in place by grooves in the frame.

To remove a shield, pry it out with your fingers, beginning at the rear of the appropriate side. To install a shield, position it over the frame rail grooves, then press down with your fingers until the shield snaps into place. Pressure must be applied along the full length of the frames to secure the shield.

The plug-in will not slide into the mainframe if the side shields are not fully seated in the frames.

Cleaning

The plug-in should be cleaned as often as operating conditions require. Accumulation of dirt on components acts as an insulating blanket and prevents efficient heat dissipation, which can cause overheating and component breakdown. Dirt also provides an electrical conduction path that can result in instrument failure.

The cabinet panels of the mainframe, in which the plug-in is installed, reduce the amount of dust reaching the interior of the instrument. Keep the cabinet panels in place for safety and cooling.

CAUTION

Avoid the use of chemical cleaning agents which might damage the materials used in this instrument. Use only Isopropyl alcohol or totally denatured ethyl alcohol. Before using any other type of cleaner, consult your Tektronix Service Center or representative.

Exterior

Loose dust accumulated on the outside of the instrument can be removed with a soft cloth or small brush. The brush is particularly useful for dislodging dirt in and around the side-shield ventilation holes and front-panel switches. Remove the side shields before cleaning them.

Interior

Cleaning the interior of the instrument should seldom be necessary. The best way to clean the interior is to blow off the accumulated dust with dry, low-velocity air (such as from a vacuum cleaner). Remove any dirt that remains with a soft brush or a cloth dampened with a mild solution of detergent and water. A cotton-tipped swab is useful for cleaning in narrow spaces, or for cleaning more delicate circuit components (refer to the topic Amplifier Hybrids, under Corrective Maintenance later in this section, for more information on Hypcon connectors).

CAUTION

Circuit boards and components must be dry before applying power to prevent damage from electrical shorts.

Visual Inspection

The plug-in should be inspected occasionally for loosely-seated or heat-damaged components. The corrective procedure for most visible defects is obvious. However, particular care must be taken if heat-damaged parts are found. Overheating usually indicates other problems in the instrument. Therefore, correcting the cause of overheating is important to prevent recurrence of the damage.

Periodic Electrical Adjustment

To ensure accurate measurements, check the electrical adjustment of this instrument after each 2,000 hours of operation, or every 24 months if used infrequently. Instructions are given in Section 2, Checks and Adjustments.

Corrective Maintenance

Corrective maintenance consists of Field Replaceable Unit (FRU) replacement and instrument repair. Special techniques required to replace FRUs in the plug-in are given here.

Ordering Parts

When ordering replacement parts from Tektronix, Inc., including the following information:

1. Instrument type
2. Instrument serial number
3. A description of the part (if electrical, include circuit number)
4. Tektronix part number

Static-Sensitive Device Classification

CAUTION

Static discharge can damage any semiconductor component in this instrument.

This instrument contains electrical components that are susceptible to damage from static discharge. Table 3-1 gives relative susceptibility of various classes of semiconductors. Static voltages of 1 kV to 30 kV are common in unprotected environments.

Observe the following precautions to avoid damage:

1. Minimize handling of static-sensitive components.
2. Transport and store static-sensitive components or assemblies in their original containers on a metal surface, or conductive foam. Label any package that contains static-sensitive assemblies or components.
3. Discharge the static voltage from your body by wearing a wrist strap while handling these components. Servicing static-sensitive assemblies or components should be performed only at a static-free work station by qualified service personnel. We recommend the use of the Static Control Mat and Wrist Strap.
4. Allow nothing capable of generating or holding a static charge on your work station surface.
5. Keep the component leads shorted together whenever possible.

6. Pick up components by the body, never by the leads.
7. Do not slide the components over any surface.
8. Avoid handling components in areas that have a floor or work-surface covering capable of generating a static charge.

TABLE 3-1
Relative Susceptibility to Damage From Static Discharge

Semiconductor Classes	Relative Susceptibility Levels ¹
MOS or CMOS microcircuits, and discrete or linear microcircuits with MOS inputs (most sensitive)	1
ECL	2
Schottky signal diodes	3
Schottky TTL	4
High-frequency bipolar transistors	5
JFETs	6
Linear microcircuits	7
Low-power Schottky TTL	8
TTL (least sensitive)	9

¹Voltage equivalent for levels.

1 = 100 to 500 V

2 = 200 to 500 V

3 = 250 V

4 = 500 V

5 = 400 to 600 V

6 = 600 to 800 V

7 = 400 to 1000 V (est.)

8 = 900 V

9 = 1200 V

(Voltage discharged from a 100 pF capacitor through a resistance of 100 ohms.)

Removing and Replacing FRUs

CAUTION

To avoid instrument damage, set the mainframe ON/STANDBY switch to STANDBY and remove the plug-in from the mainframe before removing or replacing FRUs.

To determine the location of a FRU, refer to Figure 3-1.

The side shields will have to be removed to gain access to the circuit boards and other FRUs.

The exploded-view drawing associated with the Replaceable Parts list may be helpful in the disassembly procedures that follow. This drawing is located in Section 5, at the end of this manual.

CAUTION

If the green light indicator remains lit when the STANDBY position is selected, then the switch has been left internally disabled after the servicing of the power supply. To enable the ON/STANDBY switch, refer to the Maintenance section of the mainframe Service Manual.

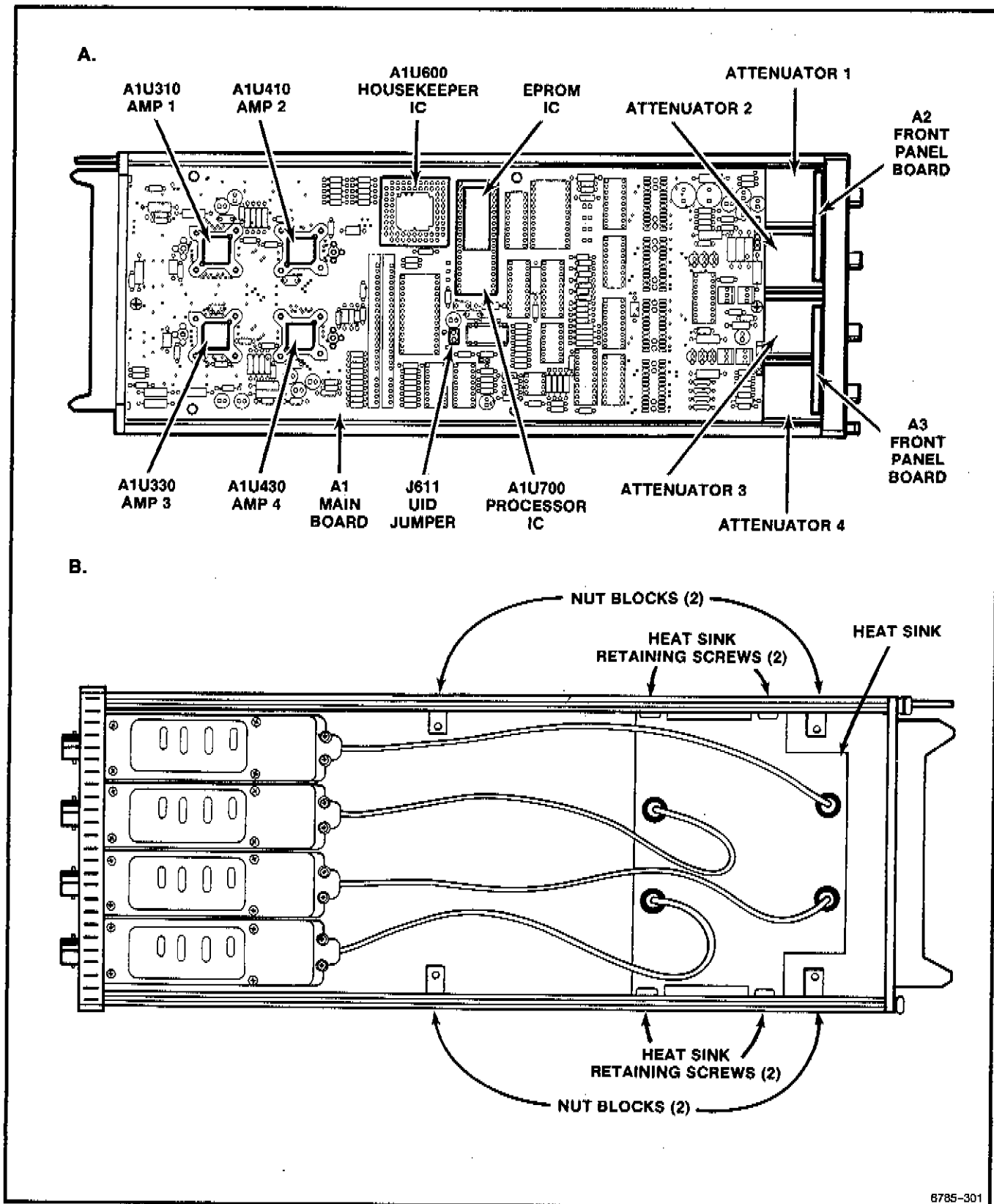

Figure 3-1. Field Replaceable Units (FRU) locator and A1 Main board securing hardware.

Semiconductor FRU Removal

CAUTION

Observe all the special precautions mentioned under the heading, "Static-Sensitive Device Classification," in this section.

Housekeeper Integrated Circuit ("Slam-Pack" ICs)

The Housekeeper IC (A1U600) is indexed to its socket by a beveled corner, as shown in Figure 3-2. The other corners are notched to fit the edges of the socket. The beveled corner aligns with a spring (small metal tab) at one corner of the socket.

Remove the Housekeeper IC as follows:

1. Unfasten the retaining clip by moving it across the tabs. It may help to push down slightly on the cover.
2. Remove the cover slowly to prevent the IC from falling out. Observe the index of the IC before removing it.
3. Remove the IC with tweezers.

CAUTION

Avoid touching the IC or the socket contacts with your fingers. Finger oils can lessen reliability.

Install the Housekeeper IC as follows:

1. Using tweezers, place the beveled corner of the replacement IC against the index spring.

CAUTION

Do not damage the spring with the beveled corner. Shorting of the two corner contacts could result.

2. Arrange the other IC corners, with the tweezers, to fit evenly at the edges of the socket.
3. Set the cover flat on the IC with its end tabs properly aligned with the mating recesses in the socket. (The cover is not symmetrical.)
4. Push the cover down, keeping it flat on the IC, and slide into place. Hold the cover in place while moving the retaining clip over the tabs on the other end.

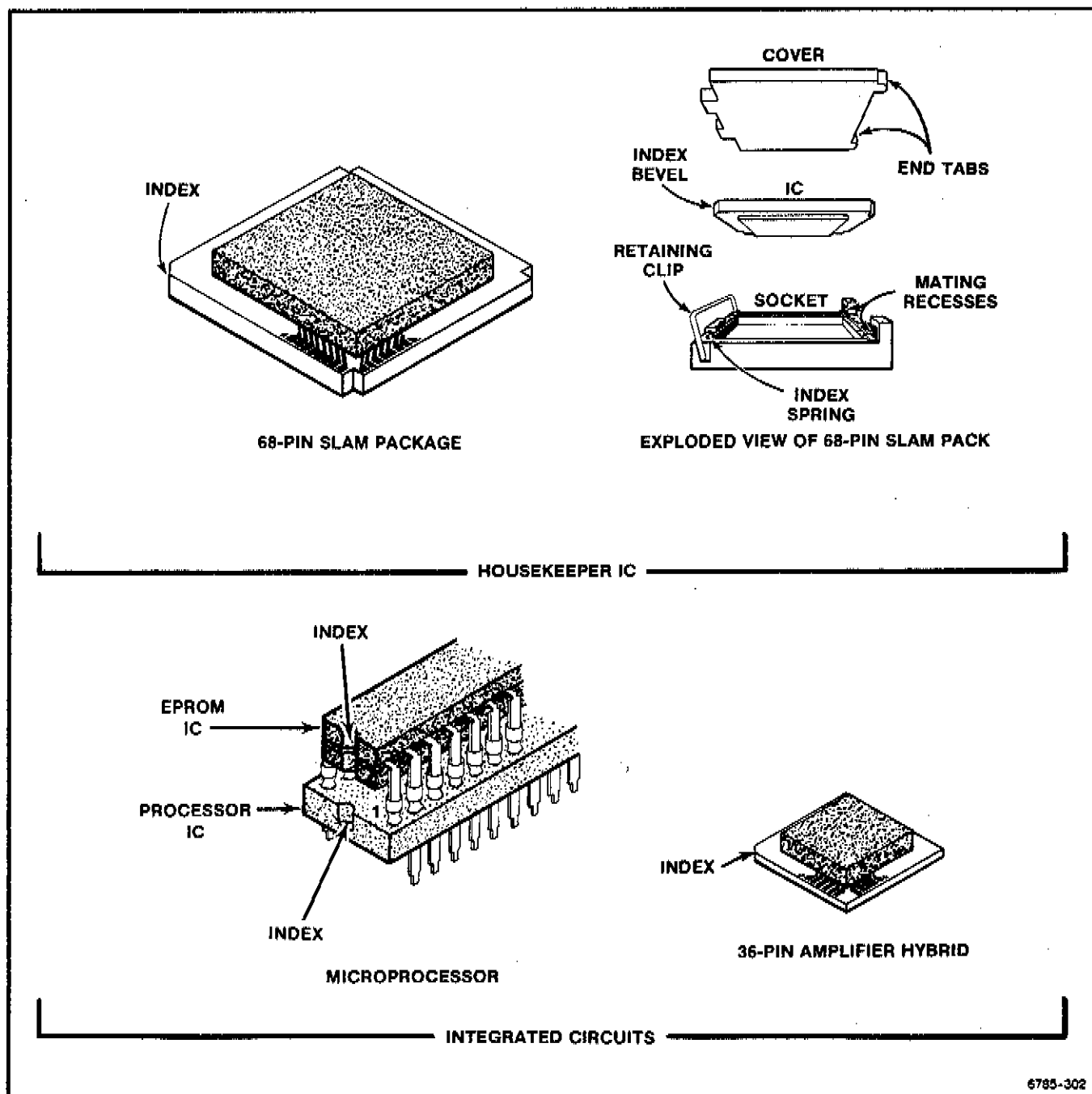

Figure 3-2. Semiconductor indexing diagram.

Amplifier Hybrids

Figure 3-3 shows an exploded view of the Hypcon (Hybrid-printed circuit connector) and gives disassembly and replacement instructions. When replacing the hybrid, do not touch the elastomer's gold-plated contacts with your fingers. Use a cleaner which will not lessen contact reliability. The Hypcon socket contacts are fragile. Use caution when removing and replacing a Hypcon to avoid damaging these contacts.

Before reinstallation, use a 4X (or greater) magnifying glass to examine the hybrid, elastomer, and the Hypcon contacts under light for dust, hair, lint, etc. If the etched circuit board surfaces require more cleaning, scrub with a soft rubber eraser. Blow or vacuum clean, while dusting the surface with a small clean brush.

If the hybrid and elastomer contact holder are contaminated, clean them by flushing or spraying with alcohol and oven dry at +50° C. **Do not scrub with a cotton-tipped swab or similar device.** (Cotton fibers may adhere to the contacts.) If the contact holder is excessively contaminated, replace it with a new one.

Tighten the mounting screws with two inch-pounds of torque (in the English Unit System) or 2.3 centimeters-kilograms (in the MKS Unit System) to secure the Hypcon to the circuit board.

Make sure that the elastomer is properly seated in the contact holder before re-mounting the assembly to the circuit board. Use care when mounting the whole assembly to the circuit board to prevent misalignment between the connector and board.

CAUTION

Because of close tolerances involved, special care must be taken to ensure correct index alignment of each Hypcon part during reassembly. (Fig. 3-3 shows the index locations.) Failure to do so can result in a cracked hybrid substrate.

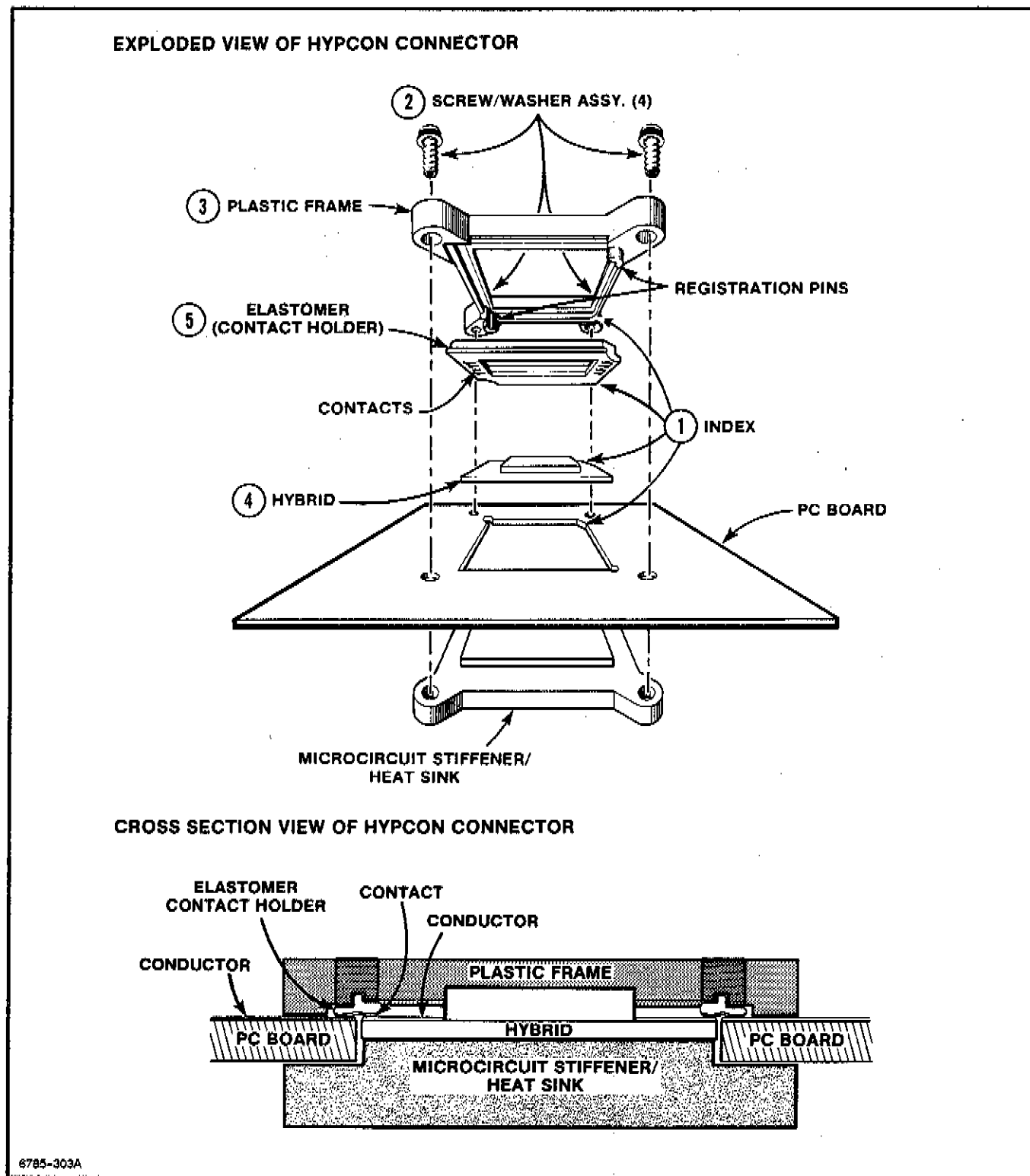

Figure 3-3. Hypcon assembly removal and replacement.

DISASSEMBLY AND REMOVAL

- 1 Notice index on circuit board (arrow) and plastic frame (pointed tab).
- 2 Unscrew and remove the 4 screw/washer assemblies.
- 3 Lift plastic frame from board.
- 4 Notice index location of hybrid and remove from circuit board with tweezers.

NOTE

Step 5 describes the removal of the elastomer from the plastic frame. This step is not necessary when replacing only the hybrid.

- 5 Notice index location of elastomer contact holder and remove from plastic frame by grasping corner with tweezers and lifting up. Do not touch the gold-plated contacts with your fingers.

REASSEMBLY AND REPLACEMENT

- a. Grasp a corner of the elastomer with tweezers and place it into plastic frame. Align keyed corner of elastomer with keyed corner of plastic frame. Tamp elastomer into plastic frame uniformly.

NOTE

Cleanliness is very important. Small hairs and elastomer flash under the contacts, which are almost invisible to the naked eye, will prevent good electrical contact. Most apparent failures of the hybrid are actually due to contamination of the Hypcon. Do not touch the gold-plated contacts with fingers.

- b. Place the hybrid into the square hole in circuit board. The hybrid is keyed so that it will fit into the circuit board in only one orientation. When the back of the hybrid rests on the heat sink pedestal, the top of the hybrid should be flush with the top of the circuit board.
- c. Place the plastic frame with elastomer installed over hybrid such that key (pointed tab) align with the corner arrow on the circuit board.
- d. Insert mounting hardware and apply two inch-pounds of torque (2.3 cm-kg) to secure connector assembly. Do not overtighten. To do so will strip the microcircuit stiffener/heat sink mounting threads.

6785-303B

Figure 3-3 (cont). Hypcon assembly removal and replacement.

EPROM IC

CAUTION

Do not remove the label affixed to the top of EPROMs. Removing this label will allow light into the chip, and may cause partial erasure of its data.

The EPROM IC is mounted on top of the Processor on the A1 Main board. (Refer to Fig. 3-1 for the location of this IC.)

Remove the EPROM IC as follows:

1. Use Insertion-Extraction Pliers (such as General Tool's Part Number U505BG, a 28-pin type) to remove the IC. An illustration of the pliers is shown in Figure 3-4.
2. Position the pliers around the outside of the IC. Squeeze the handles to grasp the IC and slowly pull it from the socket.

CAUTION

Avoid touching the removed IC pins or socket contacts with your fingers. Finger oils can lessen contact reliability.

Install the EPROM IC as follows:

1. Grasp the IC with the Insertion-Extraction Pliers. Check that all the IC pins are straight and evenly spaced.
2. Do not use the IC label as an index. Look for the index on the IC body. Align the index slot with that of the AIU700 Processor IC underneath it. (Figure 3-2 gives an illustration of this indexing.)
3. Align the pins with their respective socket contacts and slowly seat the IC.

Processor IC

The Processor IC (A1U700) is located on the A1 Main board. Refer to Figure 3-1 for its location. The EPROM IC is mounted on top of the Processor IC.

Remove the Processor IC as follows:

1. Remove the EPROM IC. Follow the removal instructions given in the preceding part of this section.
2. Use Insertion-Extraction Pliers (such as General Tool's Part Number U505BG, a 28-pin type) to remove the Processor IC.
3. Position the pliers around the outside of the IC. Squeeze the handles to grasp the IC and slowly pull it from the socket.

CAUTION

Do not damage the EPROM sockets with the pliers. Avoid touching the IC pins or the socket contacts with your fingers. Finger oils can lessen contact reliability.

Install the Processor IC as follows:

1. Grasp the replacement IC with the Insertion-Extraction Pliers. Check that all its pins are straight and evenly spaced.
2. Align the index slot on the IC with the corresponding index on its socket.
3. Align the IC pins with their respective socket contacts. Push down slowly and evenly on the IC to seat it.
4. Replace the EPROM IC on top of the Processor IC. Follow the EPROM replacement instructions given in the preceding part of this section.

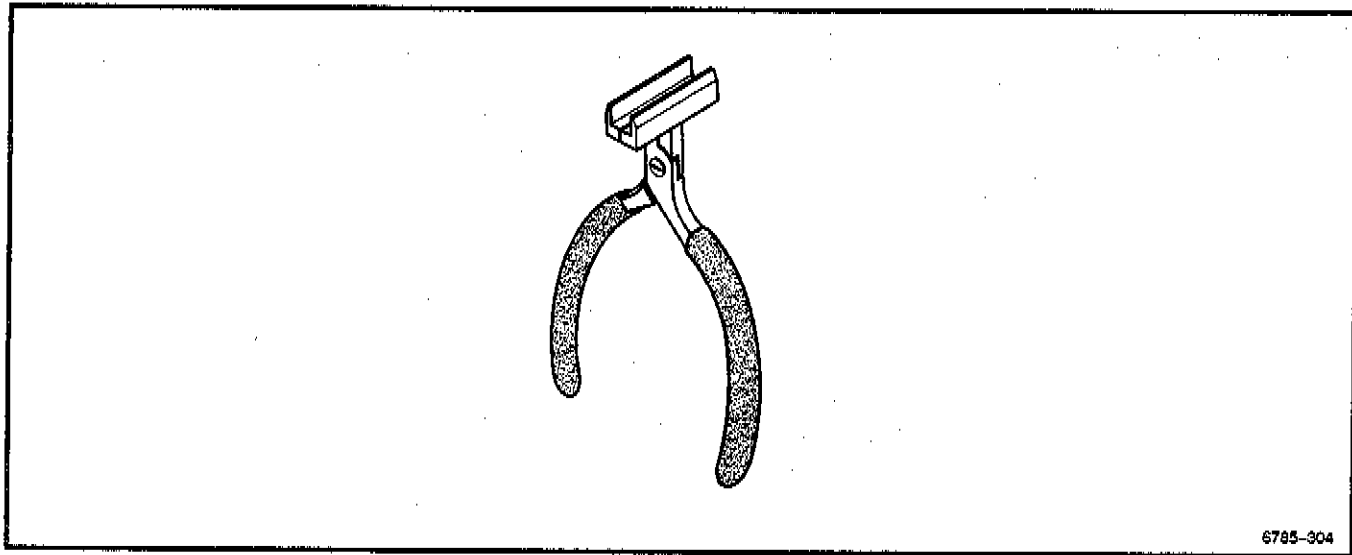

Figure 3-4. IC Insertion-Extraction Pliers.

Circuit Board and Attenuator FRU Removal

How to Remove the Front Panel

1. Unhook the return spring from the release bar, and set it aside.
2. Use a Torx T-8 screwdriver to remove the four screws that fasten the front subpanel to the top and bottom frames.
3. Pull the release bar as far out of the instrument as it will come, and leave it in that position.
4. Insert a slender, sharp-pointed tool, such as a scribe, between the front panel and the subpanel at the notch around the release bar. Gently separate the front panel from the subpanel. Use care to prevent bending the front panel.

How to Install the Front Panel

1. Check that the four screws that fasten the front subpanel to the top and bottom frames are removed.
2. Check that the release bar return spring is removed.
3. Set the plug-in on its side with the front panel facing you.
4. Pull the release bar as far out of the instrument as it will come, and leave it in that position.
5. Position the front panel so that the notch in the bottom fits over the release bar, then carefully insert the four front-panel tabs into the slots in the front subpanel. (You may need to pull the top and bottom frames away from the subpanel to allow the front-panel tabs to fit between the casting and the frames.)
6. Gently snap the edges of the front panel into place around the input connectors and the outer edges of the panel.
7. Use a Torx T-8 screwdriver to install the four screws that fasten the front subpanel to the top and bottom frames.
8. Install the release bar return spring. Orient the spring so that its loop fits over the frame hook correctly (flat against the frame section).

How to Remove and Install an A2 or A3 Front-Panel Board

1. Remove the front panel as outlined in "How to Remove the Front Panel."
2. Unplug the connector that provides electrical connection to the A1 Main board.
3. Use a Torx T-6 screwdriver to remove the two screws that fasten the A2 or A3 Front-Panel board to the front subpanel, and remove the A2 or A3 Front-Panel board.
4. To replace an A2 or A3 Front-Panel board, follow the preceding steps in reverse order.

How to Remove an Attenuator

The CH 1, CH 2, CH 3, and CH 4 Attenuators are identical.

1. Remove the front panel as outlined in "How to Remove the Front Panel."
2. Unplug the cable that connects the attenuator to the A1 Main board.
3. Use a Torx T-8 screwdriver to remove the two screws from the component side of the A1 Main board that fasten the subject attenuator (refer to Fig. 3-5).
4. Set the plug-in on its side with the attenuator bodies up.
5. Use a Torx T-6 screwdriver to remove the four screws that fasten the front of the attenuator to the front subpanel.
6. Lift up the rear end of the attenuator about 1/4-inch from the board then carefully withdraw the attenuator from the instrument.
7. Note that the two metal-on-elastomer (MOE) strips are sitting free in the MOE holder.

How to Install an Attenuator

1. Set the plug-in on its side with the pushbuttons down.
2. Put a metal-on-elastomer (MOE) strip holder on the Main board in the appropriate location (refer to Fig. 3-5).
3. Put the two new MOE strips in the holder. The exposed elastomer side of each strip should face the center of the holder.
4. Insert the BNC end of the attenuator through the hole in the front subpanel, then let it rest on the A1 Main board.
5. While holding the attenuator against the MOE assembly, turn the plug-in so that you can install the two screws that fasten the attenuator to the A1 Main board. These screws require a Torx T-8 screwdriver; **do not tighten them yet.**
6. Use a Torx T-6 screwdriver to install the four screws that fasten the attenuator to the front subpanel.
7. If presently installed, remove the four screws that fasten the top and bottom frames to the front subpanel.
8. Install the front panel as outlined in "How to Install the Front Panel."
9. Tighten the screws you installed in step 5.
10. Reattach the cable that connects the attenuator to the A1 Main board. Figure 3-1 shows the proper connection of the attenuator cables and the receptacles.

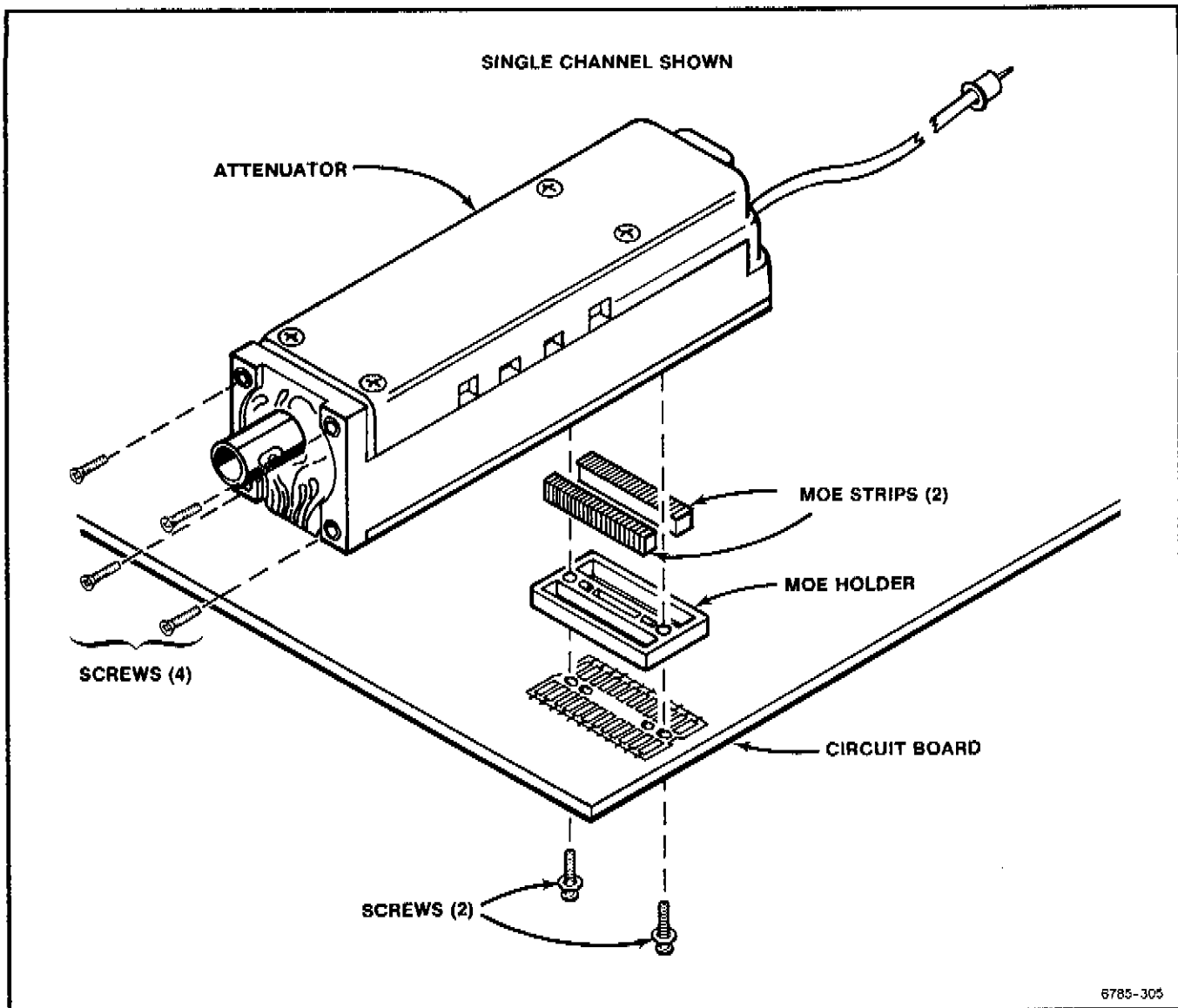

Figure 3-5. Location of screws and parts for removal of an attenuator.

How to Remove the A1 Main Board

1. Unplug the connector(s) from the Front-Panel board(s) at the A1 Main board.
2. Use a Torx T-8 screwdriver to remove the screws attaching the attenuators to the A1 Main board.
3. Unplug the cables that connect the attenuators to the A1 Main board.
4. Unhook the return spring from the release bar.
5. Use a Torx-8 screwdriver to remove the four screws that fasten the front panel to the top and bottom frames.
6. Remove the front panel and attenuators.
7. Remove the metal-on-elastomer (MOE) strips and holders.

8. Use a Torx T-15 screwdriver to remove the screws that attach the heat sink bracket to the A1 Main board.
9. Use a Torx T-10 screwdriver to remove the five screws and nut blocks that secure the A1 Main board to the top and bottom frames. Figures 3-1 and 3-6 show the nut blocks. Use a screwdriver with a narrow shaft because the screws have very little offset from the top and bottom frames.
10. Use a Torx T-15 screwdriver to remove the four screws that fasten the plastic rear panel to the top and bottom frames.
11. Carefully withdraw the A1 Main board from between the frames.
12. Remove the rear panel from the A1 Main board.

How to Install the A1 Main Board

1. Align the notches in the rear panel with the notches in the top and bottom frames. Reattach the rear panel to the replacement A1 Main board.
2. Carefully insert the A1 Main board between the frames until the plastic rear panel contacts the top and bottom frames. The board fits on the top of the center ridges of the top and bottom frames.
3. Use a Torx T-15 screwdriver to start the four screws that fasten the rear panel to the top and bottom frames.
4. Use a Torx T-10 screwdriver to start the five screws and nut blocks that clamp the A1 Main board to the top and bottom frames.
5. Use a Torx T-15 screwdriver to start the screws fastening the heat sink bracket to the A1 Main board.

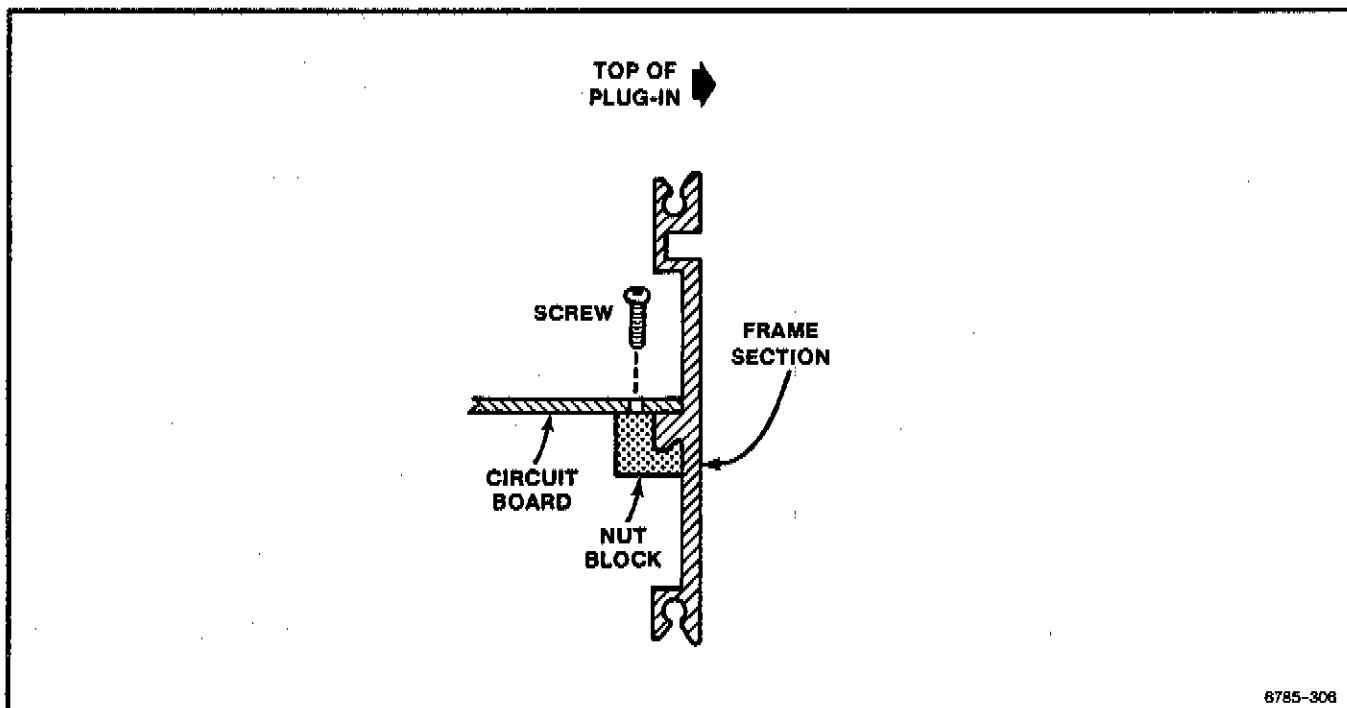

Figure 3-6. Location of a nut block securing the circuit board to the frame section.

6. Tighten the screws that you installed in steps 3, 4, and 5.
7. Replace the MOE holders on the bottom of the A1 Mother board and put MOE strips in the holders as shown in Figure 3-5.
8. Slide the front panel and attenuator assembly into position, being careful not to dislodge the MOE strips or holders.
9. Hold the attenuators against the MOE strips and start all of the screws which attach the attenuators to the A1 Main board.
10. Use a Torx T-8 screwdriver to install the four screws that fasten the front panel to the top and bottom frames.
11. Use a Torx T-8 screwdriver to tighten the screws installed in step 9.
12. Connect the cable(s) from the A2 Front-Panel board to the receptacle(s) on the A1 Main board.
13. Install the release bar return spring. Orient the spring so that its loop fits over the frame hook correctly (flat against the frame section).
14. If the A1 Main board has been replaced, then the Unit Identification (UID) number needs to be re-entered. Refer to instructions in the "Programming The Unit Identification" section, which follows.

Programming The Unit Identification

The Unit Identification (UID) is identical to the instrument's serial number and is stored in NV RAM. It is necessary to enter this number if the A1 Main board is replaced or if data in NV RAM becomes corrupted. If confirmation only of the UID is needed, then use the following procedure except skip step 4.

To enter the UID, use this procedure:

1. Connect a Terminal to the mainframe's RS-232-C port. (Refer to the mainframe User's Reference Manual for instructions on setting up the RS-232-C parameters.)
2. Inside the plug-in, move the jumper J611 (shown in Fig. 3-1) on the A1 Main board. The jumper should be vertical in its normal position. Remove the jumper and install it horizontally.
3. Install the plug-in into any compartment. Turn the power on. Wait until the Diagnostics checks are completed.
4. At the Terminal, type the command:

UID [Left|Center|Right]:“ < Serial Number > ”
 - Left|Center|Right refers to the name of the compartment.
5. At the terminal, type the command:

UID? [Left|Center|Right]
6. Set the ON/STANDBY switch to STANDBY.
7. Remove the plug-in.
8. Reinstall the jumper J611 to its vertical position on the A1 Main board.

Multi-Pin Connectors

Pin 1 on a multi-pin connector is designated with a triangle (or arrowhead) on the holder. A square pad on the circuit board denotes pin 1. When a connection is made to a circuit board, the indexing of the triangle on the multi-pin holder is determined by the square pad.

The multi-pin connector is keyed by a gap between pins 1 and 3 in the holder. (A small plastic plug covers the pin 2 position on the end of the holder.) There is a corresponding gap between pins 1 and 3 on the circuit board as shown in Figure 3-7. The female connector is illustrated by this view. (The male connector also has a similar pin arrangement, but it is not shown.)

Align the holder plug with the gap between the circuit board pins. The connector is then ready to be installed.

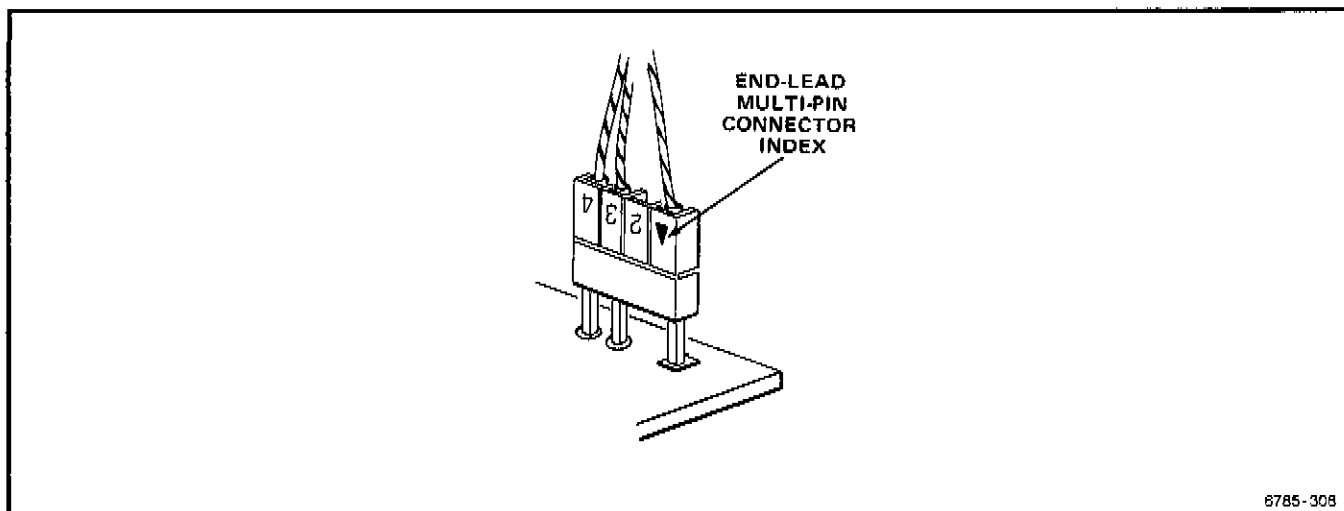

8785-308

Figure 3-7. Indexing of multi-pin connectors.

Troubleshooting

Diagnostic Troubleshooting

This section provides the information necessary to troubleshoot a faulty instrument to the Field Replaceable Unit (FRU) level. FRUs are circuit boards, attenuator modules, and integrated circuits or hybrids that are replaceable without soldering. The primary means for troubleshooting is to use the error index code output from the Diagnostics or Self-Tests and cross-reference them to the suspect FRU(s) in the FRU Guide tables. After an FRU is replaced, some recalibration of the instrument is normally required (this is discussed further below).

Diagnostics Overview

The processor runs a set of Kernel Tests prior to the Self-Tests. If this is successful, then the Self-Tests run to verify the functionality of each of the subsystems. Any failure causes the instrument to enter Extended Diagnostics and to display the error index code(s) in a diagnostic menu. Extended Diagnostics tests are a superset of the Self-Tests.

The Kernel Tests and Self-Tests/Extended Diagnostics produce and format error index codes differently, so they are covered separately.

Some of these tests that may indicate faulty FRUs are not run automatically during the Self-Tests (that is, some errors codes are only generated by manually selecting tests).

The next two subsections provide a quick overview of Kernel Tests and Extended Diagnostics.

Kernel Diagnostics

Each time the front-panel ON/STANDBY switch is set to ON, the mainframe and plug-ins perform Kernel Tests on their microprocessor subsystems and Self Test Diagnostics on all of their major circuits.

CAUTION

Turning the instrument power off during the execution of the Diagnostic tests may result in losing some or all of the non-volatile RAM data (such as stored settings, calibration constants, etc.). This could affect normal instrument operation in unpredictable ways.

After the plug-in is powered-up and the MPU has reset, the plug-in begins a sequence of test routines to determine if its kernel systems are operating properly. If any of these tests fails, then it is unlikely that the plug-in can communicate failure information to the mainframe. The flashing of a fault code on the front panel CH 1 and CH 2 LEDs indicates a particular failure. This fault code indicates which Kernel Test is failing.

The following description explains how to read the fault code:

If the plug-in Kernel Tests detect a fault, then the CH 2 LED is flashed eight times to display a fault code. Each time the CH 2 LED turns on, count the occurrences. If the CH 1 LED is lit during a cycle of the CH 2 LED, then the test corresponding to the current count accumulated is the one which failed. Refer to the timing diagram in Figure 3-8 for an example LED fault code. The timing diagram illustrates a test number 2 failure.

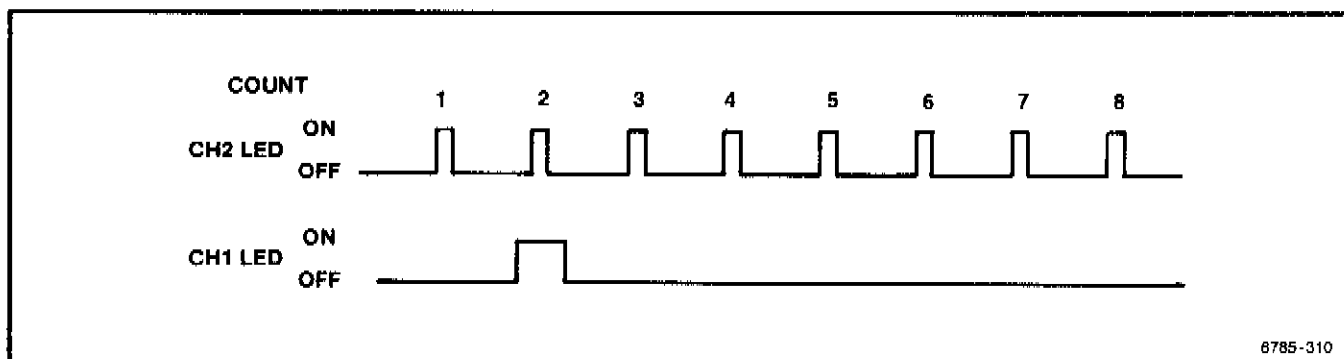

Figure 3-8. Sample LED fault code timing diagram.

The Kernel Tests are:

1. ROM Checksum Test
2. Non-volatile RAM Test
3. Housekeeper IC Test

1. The ROM Checksum Test computes a checksum of the content of the firmware ROM. This calculated checksum is then compared with a checksum stored in the ROM. If the checksums do not match, the test fails, and fault code 1 is reported. After the fault code is reported by flashing the front-panel LEDs, the plug-in attempts to begin normal operation, but it is unlikely that the instrument can function properly with a bad ROM Checksum.
2. The non-volatile RAM (NV RAM) Test verifies that the NV RAM is functioning properly. Since the NV RAM contains calibration information which must remain undamaged, this test does not alter critical data. If the testing algorithm detects a failure, then the plug-in reports a fault code of 2, and repeatedly loops the NV RAM Test. The instrument continues looping the NV RAM Test until the power is removed. Until the condition causing the NV RAM Test to fail is corrected, the mainframe does not recognize the plug-in.

The NV RAM Test could corrupt calibration data stored in the NV RAM if the power is cycled or removed during this test. If corruption occurs, then the Calconstant Checksum is corrupted as well. Furthermore, at the next power-up, the plug-in resets the calibration constants to default ROM settings and reports a plug-in calconstant checksum error during mainframe-invoked, Power-up Diagnostics. After the mainframe/plug-in system is run through an Enhanced Accuracy cycle, the plug-in is once again properly calibrated.

3. The Housekeeper IC Test verifies the functionality of the Housekeeper IC. The Housekeeper IC performs many 'housekeeping' chores of the amplifier, including channel sequencing, refreshing the analog control voltage system, latching amplifier step gain settings, and the communications with the mainframe. This test exercises this IC and records the IC's reactions using an algorithm similar to the algorithm that signature analysis uses. If the resulting signature of the Housekeeper IC does not match a known good signature, then the test fails and reports a fault code of 3. Also, the test is executed repeatedly if it fails. The instrument continues looping the Housekeeper IC Test until power is removed. Until the condition causing the Housekeeper IC Test to fail is corrected, the mainframe does not recognize the plug-in.

After all power-on Kernel Tests have completed and successfully passed, the plug-in initializes its settings and communicates with the mainframe.

Self Test/ Extended Diagnostics

First, the plug-in must successfully power-up, initialize its settings, and establish communication with the mainframe. Then, the mainframe requests that the plug-in execute its Self-Test routines (unless the mainframe's Self-Tests are disabled, in which case all the Self-Tests are ignored). Return to normal operation or entry into the New Configuration calibration, as discussed below, indicates successful completion of Self-Test Diagnostics. Any failures cause the instrument to display the Extended Diagnostics menu. Record the displayed error codes for the failed circuit block(s). You may have to step through several pages of the menu display to find all the failure codes.

The format of the error index codes is based on the Extended Diagnostics menu structure. The Extended Diagnostics menus are in a three level hierarchy with the Block menu at the highest level. Each plug-in is one Block. A Block is broken into a number of parts or circuit areas in the Area menu, the second level. Touching the Area label at the bottom of the menu displays the Area menu for the selected Block. Each circuit Area has a Routine menu, the third level, associated with it that has one or more selectable Routines. Routines are the smallest test units that are selectable and runnable. This Block, Area, and Routine menu hierarchy generates the error index codes.

Extended Diagnostics error index codes are five digit codes whose first character indicates the subsystem or plug-in unit tested. The last four digits are hexadecimal (hex) numbers that indicate the Block, Area, Routine and specific failure mode. For example, R1241 is decoded as follows:

- | | |
|---|--|
| R | Right Plug-in |
| 1 | Block name - plug-in |
| 2 | Area name - Group I |
| 4 | Routine name - Checksum Probe |
| 1 | Failure Identity - specific failure mode |

The subsystem character of an error index code is one of the following, and indicates the compartment in which the plug-in is installed. In the tables in this section, only the four digit failure code is listed; the prefix L, C, or R is omitted.

- | | |
|---|---------|
| L | -Left |
| C | -Center |
| R | -Right |

Front-panel controls are active during the Self-Test sequence and any disturbance causes a test failure.

Self-Test Diagnostics test the following:

- Attenuator relay driver
- Probe coding
- Calibration constant checksums
- Calibration constant values
- A/D and D/A converters
- Probe power fuses
- Signal path

Using the Self Tests/Extended Diagnostics

After all Extended Diagnostic/Self-Tests have run, any resultant error index codes appear on the display next to the associated circuit block names in the Extended Diagnostics menu. Each circuit block that had a failure gives the first error encountered and the number of failures in the Block. Select the label of a failed Block then select the Area label to get a more complete list of the error index codes in a Block. Selecting the Routine label shows the lowest level test routines in the selected Area. The currently selected Block, Area, and Routine are shown. Several operating mode selectors are available on the screen. When certain test routines are selected, some of these operating modes are unselectable.

Refer to the mainframe User's Reference manual for information on Extended Diagnostics or Extended Test menus and operation.

New Configuration Calibration

When a plug-in unit is first installed in a mainframe or when one is moved to a different compartment in the mainframe, the instrument is in a new configuration mode. After the instrument runs the Power-Up Diagnostics, it recalibrates itself for the new configuration. During this calibration, the message "**Powerup new configuration partial calibration occurring**" appears. If the calibration is successful (as indicated by a message), the instrument enters the normal operating mode.

Field Replaceable Unit (FRU) Guide

This section correlates error index codes resulting from Diagnostic tests with the hybrid, integrated circuit (IC), module, or board FRU(s) suspected of causing each error. The FRU(s) in each category are listed in most-to-least probable cause order (assuming only one error is indicated). If any diagnostic errors occur, inspect the suspect FRU for loose connections and components. Repeat the Diagnostic test. If any diagnostic errors occur again, replace the suspect FRU(s) with a known good FRU(s). Verify that the new FRU is a correct replacement for the old FRU. If the old FRU contains firmware, then verify that the new firmware version is either the same version as, or an upgraded version of, the old firmware version.

Abbreviations of FRU Names

All boards are listed here with the abbreviation used in the FRU tables below:

Abbreviation	Name	Designator
Main	Main board	A1
Front2	Front Panel board	A2
Front3	Front Panel board	A3

Abbreviations of Component and Module Names

All active components and modules are listed here with the abbreviation used in the FRU tables below.

Abbreviation	Name	Designator
MPU	Processor	A1U700
EPROM	Firmware	on A1U700
HK	Housekeeper	A1U600
Att1	Attenuator, channel 1	
Att2	Attenuator, channel 2	
Att3	Attenuator, channel 3	
Att4	Attenuator, channel 4	
Amp1	Amplifier, channel 1	A1U310
Amp2	Amplifier, channel 2	A1U410
Amp3	Amplifier, channel 3	A1U330
Amp4	Amplifier, channel 4	A1U430

Error Index Codes

This table lists the error codes possible in the Kernel Tests.

Error Code	Suspect Module, Hybrid, or IC FRU(s)	Suspect Board FRU(s)
1	EPROM, MPU	Main
2		Main
3	HK, MPU	Main

This table lists the error messages possible in the Self-Tests and Extended Diagnostics.

Error Index	Suspect Module, Hybrid, or IC FRU(s)	Suspect Board FRU(s)
-1111	Att	Main
-1121		Main
-1131		Main
-1141		Main
-1211		Main
-1221	Att	Main
-1311	HK	Main
-1811	Amp, HK	Main
-1821	Att, Amp, HK	Main

Interconnections are not listed but should be considered as possible problem sources.

This table lists the error messages resulting from Enhanced Accuracy. Enhanced Accuracy is available after the system has a 20-minute warmup period.

Test	Suspect Hybrid/ IC FRU(s)	Suspect Board FRU(s)
-1411	Att1	Main
-1421	Att1	
-1431	Amp1	
-1441	Amp1	
-1451	Att1, Amp1	
-1461	Amp1	
-1471	Att1, Amp1	
-1481	Amp1	
-1491	Amp1	
-14A1	Amp1	
-1511	Att2	Main
-1521	Att2	
-1531	Amp2	
-1541	Amp2	
-1551	Att2, Amp2	
-1561	Amp2	
-1571	Att2, Amp2	
-1581	Amp2	
-1591	Amp2	
-15A1	Amp2	

Troubleshooting

Test	Suspect Hybrid/ IC FRU(s)	Suspect Board FRU(s)
-1611	Att3	
-1621	Att3	
-1631	Amp3	Main
-1641	Amp3	Main
-1651	Att3, Amp3	Main
-1661	Amp3	Main
-1671	Att3, Amp3	Main
-1681	Amp3	Main
-1691	Amp3	Main
-16A1	Amp3	Main
-1711	Att4	
-1721	Att4	
-1731	Amp4	Main
-1741	Amp4	Main
-1751	Att4, Amp4	Main
-1761	Amp4	Main
-1771	Att4, Amp4	Main
-1781	Amp4	Main
-1791	Amp4	Main
-17A1	Amp4	Main

Section 4

Theory of Operation

This section describes and illustrates (refer to Fig. 4-1) the plug-in block diagram, including signal flow and control flow. This section also discusses the power supplies for the plug-in.

Block Diagram Description

Signal Flow

The CH 1, CH 2, CH 3 and CH 4 Amplifier circuits are identical, therefore this section describes only the CH 1 Amplifier.

The display of a signal begins with the inputting of a signal directly to the CH 1 input connector (perhaps with a probe) and proceeds as follows:

CH 1 input connector → CH 1 Attenuator →
→ CH 1 Aux Signal
CH 1 Amplifier → CH 1 Trigger Signal
→ CH 1 Display Signal

The input coupling mode is either AC, DC, or Off. In the AC and DC coupling modes, the input signal is coupled to the Attenuator. In the Off Coupling mode, the signal path is open.

During self-calibration, the mainframe supplies the signal to the CH 1 Attenuator.

The CH 1 Attenuator contains resistive dividers, capacitive dividers, an ac coupling capacitor, relays, and a buffer amplifier. The CH 1 Amplifier provides gain switching and bandwidth limit filters.

The plug-in contains a microprocessor (MPU) that communicates with the mainframe. The MPU also constantly monitors the input Overload Sense and the Probe Data communication lines. The operation of the MPU is through the internally stored program in its read only memory (ROM). The MPU stores the plug-in calibration constants in random access memory (RAM). A battery backs-up memory; therefore the internal calibration constants are not lost upon power-down. Also, when powering-down, the mainframe stores the oscilloscope's settings. When the system re-powers, the mainframe restores and transmits these settings to the plug-in.

The MPU communicates with the mainframe through a peripheral IC called the Housekeeper. The Housekeeper converts the 8-bit data bytes from the MPU into a serial data signal. This signal is sent to the mainframe. Conversely, the Housekeeper converts the serial data signal from the mainframe into 8-bit data bytes for the processor to read. The MPU stores the channel switching sequence in the Housekeeper. The Housekeeper also updates the analog control voltages.

The MPU uses an analog-to-digital (A/D) converter to read the value of the Overload Sense and Probe Data lines. The A/D converter is also used in the Self-Tests.

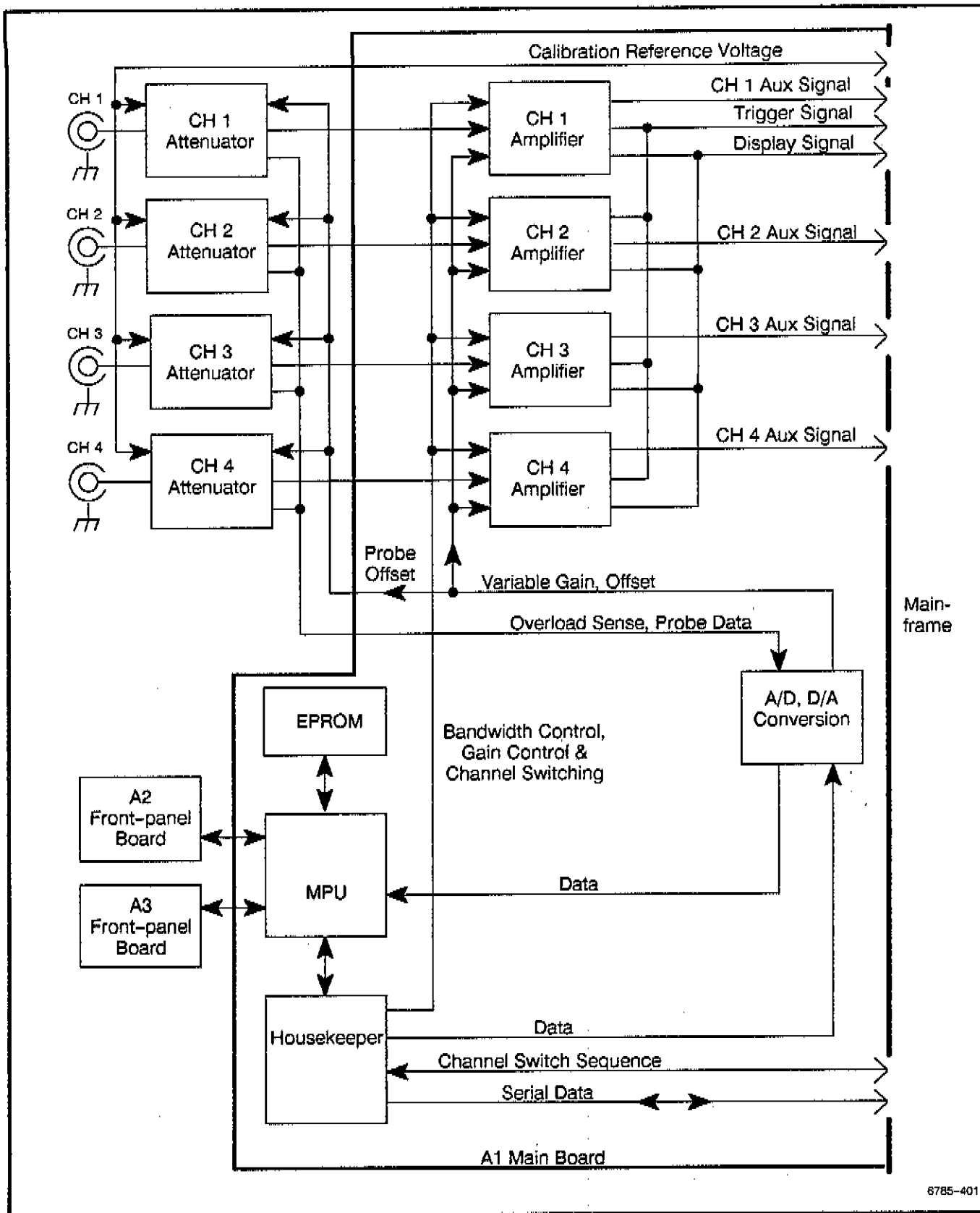

Figure 4-1. 11A34 Four-Channel Amplifier.

The MPU reads the front-panel pushbuttons. The MPU tells the mainframe when a front-panel button is pushed. Pushing a button selects that button's corresponding channel. The mainframe then tells the plug-in what action to take (for example, display the selected channel and turn on that channel's respective front-panel LED).

Control Flow

Under the control of the mainframe's channel switch sequencing signals, the Housekeeper sequentially turns a channel on or off. The MPU and Housekeeper control the settings of the amplifier and the attenuator.

Power

The mainframe supplies all the power to the plug-in.

REPLACEABLE PARTS

PARTS ORDERING INFORMATION

Replacement parts are available from or through your local Tektronix, Inc. Field Office or representative.

Changes to Tektronix instruments are sometimes made to accommodate improved components as they become available, and to give you the benefit of the latest circuit improvements developed in our engineering department. It is therefore important, when ordering parts, to include the following information in your order: Part number, instrument type or number, serial number, and modification number if applicable.

If a part you have ordered has been replaced with a new or improved part, your local Tektronix, Inc. Field Office or representative will contact you concerning any change in part number.

Change information, if any, is located at the rear of this manual.

ITEM NAME

In the Parts List, an Item Name is separated from the description by a colon (:). Because of space limitations, an Item Name may sometimes appear as incomplete. For further Item Name identification, the U.S. Federal Cataloging Handbook H6-1 can be utilized where possible.

FIGURE AND INDEX NUMBERS

Items in this section are referenced by figure and index numbers to the illustrations.

INDENTATION SYSTEM

This mechanical parts list is indented to indicate item relationships. Following is an example of the indentation system used in the description column.

```

1 2 3 4 5           Name & Description
Assembly and/or Component
Attaching parts for Assembly and/or Component
    **** END ATTACHING PARTS ****
Detail Part of Assembly and/or Component
Attaching parts for Detail Part
    **** END ATTACHING PARTS ****
Parts of Detail Part
Attaching parts for Parts of Detail Part
    **** END ATTACHING PARTS ****
  
```

Attaching Parts always appear in the same indentation as the item it mounts, while the detail parts are indented to the right. Indented items are part of, and included with, the next higher indentation. The separation symbol - - - * - - - indicates the end of attaching parts.

ABBREVIATIONS

INCH	ELECTRN	ELECTRON	IN	INCH	SE	SINGLE END
#	ELEC	ELECTRICAL	INCAND	INCANDESCENT	SECT	SECTION
ACTR	ELCTLT	ELECTROLYTIC	INSUL	INSULATOR	SEMICON	SEMICONDUCTOR
ADPTR	ELEM	ELEMENT	INTL	INTERNAL	SHLD	SHIELD
ALIGN	EPL	ELECTRICAL PARTS LIST	LPHLDR	LAMPHOLDER	SHLDR	SHOULDERED
AL	EQPT	EQUIPMENT	MACH	MACHINE	SKT	SOCKET
ASSEM	EXT	EXTERNAL	MECH	MECHANICAL	SL	SLIDE
ASSY	FIL	FILLISTER HEAD	MTG	MOUNTING	SLFLKG	SELF-LOCKING
ATTEN	FLEX	FLEXIBLE	NIP	NIPPLE	SLVG	SLEEVING
AWG	FLH	FLAT HEAD	NON WIRE	NOT WIRE WOUND	SPR	SPRING
BD	FLTR	FILTER	OBD	ORDER BY DESCRIPTION	SQ	SQUARE
BRKT	FR	FRAME or FRONT	OD	OUTSIDE DIAMETER	SST	STAINLESS STEEL
BRS	FSTNR	FASTENER	OVH	OVAL HEAD	STL	STEEL
BRZ	FT	FOOT	PH BRZ	PHOSPHOR BRONZE	SW	SWITCH
BSHG	FXD	FIXED	PL	PLAIN or PLATE	T	TUBE
CAB	GSKT	GASKET	PLSTC	PLASTIC	TERM	TERMINAL
CAP	HDL	HANDLE	PN	PART NUMBER	THD	THREAD
CER	HEX	HEXAGON	PNH	PAN HEAD	THK	THICK
CHAS	HEX HD	HEXAGONAL HEAD	PWR	POWER	TNSN	TENSION
CKT	HEX SOC	HEXAGONAL SOCKET	RCPT	RECEPTACLE	TPG	TAPPING
COMP	HLCPS	HELICAL COMPRESSION	RES	RESISTOR	TRH	TRUSS HEAD
CONN	HLEXT	HELICAL EXTENSION	RGD	RIGID	V	VOLTAGE
COV	HV	HIGH VOLTAGE	RLF	RELIEF	VAR	VARIABLE
CPLG	IC	INTEGRATED CIRCUIT	RTNR	RETAINER	W/	WITH
CRT	ID	INSIDE DIAMETER	SCH	SOCKET HEAD	WSHR	WASHER
DEG	IDNT	IDENTIFICATION	SCOPE	OSCILLOSCOPE	XFMR	TRANSFORMER
DWR	IMPLR	IMPELLER	SCR	SCREW	XSTR	TRANSISTOR

CROSS INDEX - MFR. CODE NUMBER TO MANUFACTURER

Mfr. Code	Manufacturer	Address	City, State, Zip Code
01536	TEXTRON INC CAMCAR DIV SEMS PRODUCTS UNIT	1818 CHRISTINA ST	ROCKFORD IL 61108
22599 80009	AMERACE CORP ESNA DIV TEKTRONIX INC	15201 BURBANK BLVD SUITE C 4900 S W GRIFFITH DR P O BOX 500	VAN NUYS CA 91411 BEAVERTON OR 97077
83385	MICRODOT MANUFACTURING INC GREER-CENTRAL DIV	3221 W BIG BEAVER RD	TROY MI 48098
91260 TK1326 TK1918	CONNOR SPRING AND MFG CO NORTHWEST FOURSLIDE INC SHIN-ETSU POLYMER AMERICA INC	1729 JUNCTION AVE 5858 WILLOW LANE 1181 NORTH 4TH ST	SAN JOSE CA 95112 LAKE OSWEGO OR 97034 SAN JOSE CA 95112

Fig. & Index No.	Tektronix Part No.	Serial/Assembly No.		Qty	12345 Name & Description	Mfr.	
		Effective	Dscont			Code	Mfr. Part No.
1-1	366-0600-00			4	PUSH BUTTON:0.269 X 0.409,ABS	80009	366-0600-00
-2	366-1058-00			1	KNOB:GRAY,0.625 X 0.255 X 0.485 (ATTACHING PARTS)	80009	366-1058-00
-3	214-1095-00			1	PIN,SPRING:0.187 L X 0.094 OD,STL,CD PL (END ATTACHING PARTS)	22599	52-022-094-0187
-4	105-0076-04			1	RELEASE BAR,LCH:PLUG-IN UNIT	80009	105-0076-04
-5	214-1280-00			1	SPRING,HLCPS:0.14 OD X 1.126 L,TWIST LOOP	91260	ORDER BY DESCR
-6	214-1054-00			1	SPRING,FLAT:0.825 X 0.322,SST	TK1326	ORDER BY DESCR
-7	105-0075-00			1	BOLT,LATCH:	80009	105-0075-00
-8	333-3164-00			1	PANEL,FRONT: (ATTACHING PARTS)	80009	333-3164-00
-9	211-0392-00			4	SCREW,MACHINE:4-40 X 0.25,FLH,82 DEG,STL (END ATTACHING PARTS)	80009	211-0392-00
-10	348-0235-00			2	SHLD GSKT,ELEK:FINGER TYPE,4.734 L	80009	348-0235-00
-11	386-5219-00			1	SUBPANEL,FRONT:	80009	386-5219-00
-12	670-9336-00			2	CIRCUIT BD ASSY:FRONT PANEL (SEE A2,A3) (ATTACHING PARTS)	80009	670-9336-00
-13	211-0390-00			4	SCREW,MACHINE:2-56 X 0.188,PH,STL CD PL (END ATTACHING PARTS)	80009	211-0390-00
-14	174-0159-00			2	CA ASSY,SP,ELEC:6,26 AWG,3.0 L,RIBBON	80009	174-0159-00
-15	426-2061-00			1	FR SECT,PLUG-IN:LOWER,ALUMINUM (ATTACHING PARTS)	80009	426-2061-00
-16	211-0392-00			2	SCREW,MACHINE:4-40 X 0.25,FLH,82 DEG,STL (END ATTACHING PARTS)	80009	211-0392-00
-17	334-3540-00			1	MARKER,IDENT:MARKED WARNING	80009	334-3540-00
-18	119-2000-00			4	ATENUATOR:ACTIVELY TRIMMED NOVAR ATTENUATOR & BUFFER AMPLIFIER (ATTACHING PARTS)	80009	119-2000-00
-19	211-0390-00			16	SCREW,MACHINE:2-56 X 0.188,PH,STL CD PL	80009	211-0390-00
-20	211-0391-00			8	SCREW,MACHINE:2-56 X 0.437,P4,STL CD PL (END ATTACHING PARTS)	80009	211-0391-00
-21	354-0654-00			4	RING,CONN ALIGN:BNC	80009	354-0654-00
-22	352-0780-00			4	HOLDER,CNDCT:ELASTOMERIC	80009	352-0780-00
-23	131-3383-01			8	CONN ASSY,ELEC:ELASTOMERIC,3.8MM X 3.0MM X 24.0MM,D.4MM L CONTACT PT	TK1918	.4PX24X3.8X3.0
-24	220-0022-00			4	NUT BLK:0.4 X 0.25 X 0.33,4-40 THRU,NI SIL (ATTACHING PARTS)	80009	220-0022-00
-25	211-0304-00			4	SCR,ASSEM WSHR:4-40 X 0.312,PNH,STL,T9 TORX (END ATTACHING PARTS)	01536	ORDER BY DESCR
-26	426-2060-00			1	FR SECT,PLUG-IN:UPPER,ALUMINUM (ATTACHING PARTS)	80009	426-2060-00
-27	211-0392-00			2	SCREW,MACHINE:4-40 X 0.25,FLH,82 DEG,STL (END ATTACHING PARTS)	80009	211-0392-00
-28	334-3438-00			1	MARKER,IDENT:MARKED TURN OFF POWER	80009	334-3438-00
-29	214-1061-00			1	CONTACT,ELEC:GROUNDING,CJ BE	80009	214-1061-00
-30	337-1064-12			2	SHIELD,ELEC:SIDE FOR PLUG-IN UNIT	80009	337-1064-12
-31	670-8976-00			1	CIRCUIT BD ASSY:MAIN (SEE A1)	80009	670-8976-00
-32	156-2962-00			1	.MICROCKT,DGTL:NMOS,MICROCOMPUTER,8 BIT W/ .SOCKET,EPROM	80009	156-2962-00
-33	160-4009-04			1	.MICROCKT,DGTL:HMOS,16385 X 8 EPROM,PRGM	80009	160-4009-04
-34	165-2089-04			4	.MICROCKT,LINEAR:VERT PREAMP,200 OHM	80009	165-2089-04
-35	156-2625-00			1	.MICROCKT,DGTL:NMOS,CUSTOM,SENESCHAL	80009	156-2625-00
-36	343-0543-00			2	RETAINER,MIRROR:LEFT & RIGHT,ABS BLACK	80009	343-0543-00
-37	407-3363-00			1	BRACKET,HEAT SK:ALUMINUM (ATTACHING PARTS)	80009	407-3363-00
-38	211-0711-00			4	SCR,ASSEM WSHR:6-32 X 0.25,PNH,STL,TORX,T15 (END ATTACHING PARTS)	01536	ORDER BY DESCR
-39	386-5296-00			1	PANEL,REAR: (ATTACHING PARTS)	80009	386-5296-00
-40	213-0904-00			4	SCREW,TPG,TR:6-32 X 0.5,PNH,STL (END ATTACHING PARTS)	83385	ORDER BY DESCR
					STANDARD ACCESSORIES		
	070-5921-00			1	MANUAL,TECH:USERS,11A34	80009	070-5921-00

Fig. & Index No.	Tektronix Part No.	Serial/Assembly No. Effective	Discort	Qty	12345 Name & Description	Mfr. Code	Mfr. Part No.
1-					OPTIONAL ACCESSORIES		
	070-6785-00			1	MANUAL, TECH:SERVICE REF, 11A34	80009	070-6785-00

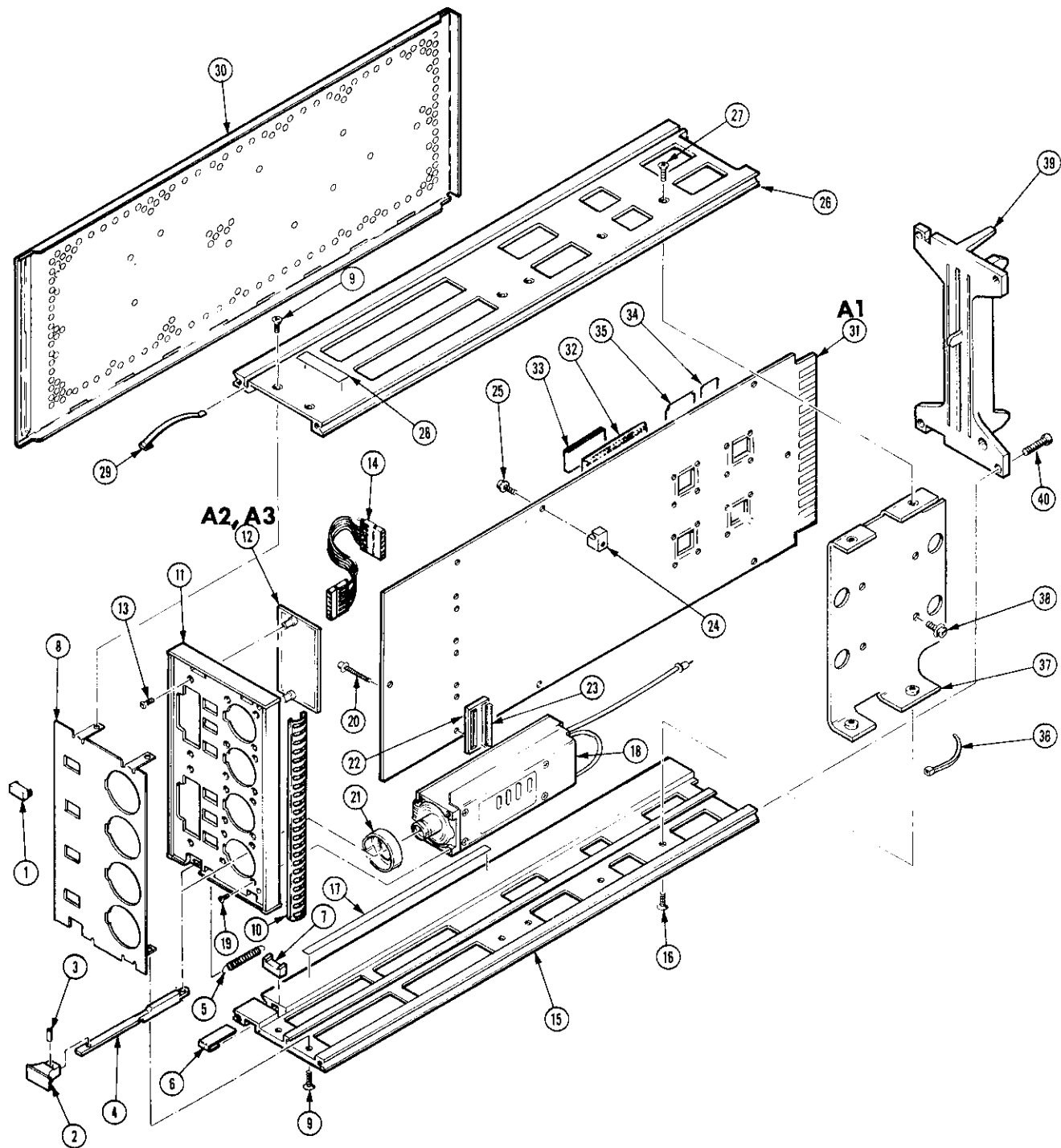

FIG. 1 EXPLODED
11A34