

SERVICETEKNOTES

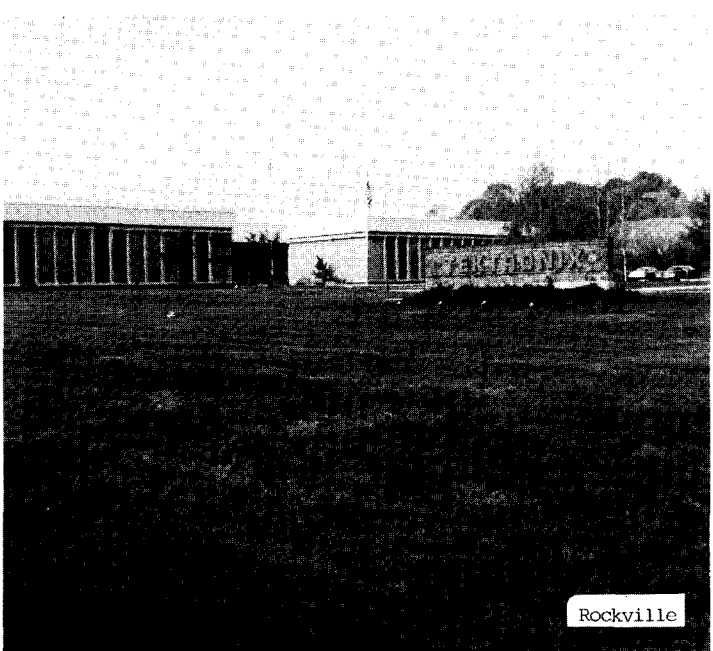

Philadelphia



Rockville

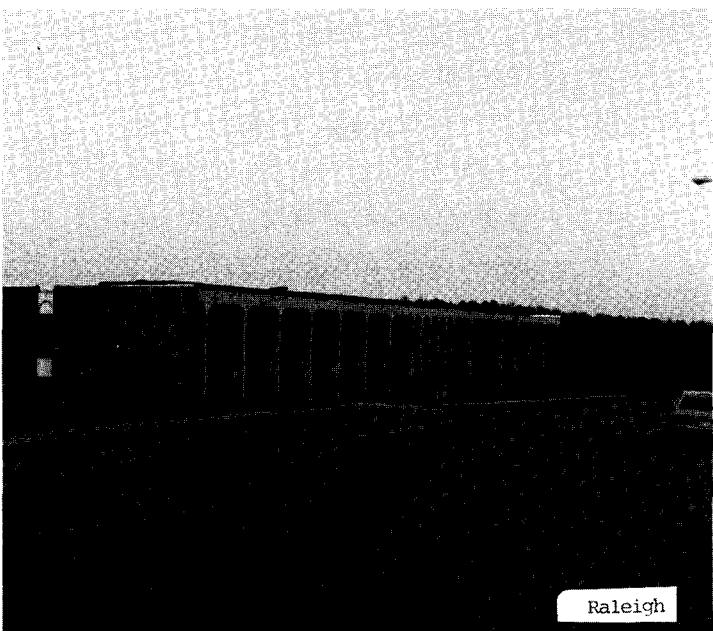

Raleigh



Detroit

TABLE OF CONTENTS

CG551AP TO CG5001 CONVERSION KIT. 1

C50 SERIES CAMERA SHUTTER TIMING. 1

DC510/DC5010 INCORRECT COUNTING ABOVE 300 MHZ 1

DM5010 VOLTAGE READING CHANGE ON 1000 VOLT AC RANGE 4

PARTS NEEDED TO CONVERT 1900 TO R1900 4

P7001: FIRST AND LAST BIT OF WAVEFORM DATA MAY BE DISPLACED VERTICALLY . . 4

SC502/SC504 HALO SUPPRESSION CRT MOD KIT. 4

SPG 1/2, 11/12 MODIFICATION 4

S-3200 CLOCK PHASE SIGNAL SPLITTERS, MODIFIED - M45960. 5

S-3200 VERDICT F050 5

S-3200 VERSION 4.2 AND 4.3 SOFTWARE 5

S-3200 2942 INSTRUCTION DECODE CARD MODIFICATION M46824 6

TSG 13 SYNC AMPLITUDE 7

WEIGHTING FILTERS FOR THE 380 7

19" AND 25" DVST DISPLAYS PIN 35 NAME CHANGED 8

69MXX SERIES THUMB LATCHES. 8

69M00/69M01/69M10 HORIZONTAL JITTER 8

147A/149A CABLE HARNESSSES 8

149A POWER SUPPLY 9

149A VIR DETECTOR TEMP STABILITY. 9

492/P SHAPE FACTOR SPECIFICATION CHANGE 9

492/P V.R. CIRCUIT BOARD REPLACEMENT. 9

492/P, 496/P - A58U4305 REPLACEMENT KIT 10

496/PAND 492/P MIXER DIODE A12A1 --- PART NUMBER INCORRECT. 10

4006-1/4051/4052 HARD COPY NOISE MOD #47967 11

4014/14-1, 4015/15-1, 4016-1 JACKSCREWS ADDENDUM. 11

4016-1 SMALLEST CHARACTERS LINE SPACING VARIES. 12

4023 DISPLAY -- HORIZONTAL ADJUSTMENTS. 12

604A CRT PART NUMBERS REVERSED. 12

650HR SERIES MODIFICATION 13

650HR SERIES RACK SLIDES. 13

690SR LINE RATE CHANGE. 13

690SR/6942 VIDEO AMP VMOS FETS. 14

1420 SERIES 15

1440 I3B, 147, 149, 1900 - TELETEXT DATA.15

1804 PRESSURE SWITCH S35.15

1885 DUAL STATION MULTIPLEXER, A10 MODULE REDESIGNED, M44285.16

1885 DUAL STATION MULTIPLEXER, A60 MODULE REDESIGNED, M44991.16

1980 RACK SLIDE LATCHES16

2213/2215 TRIGGER SYSTEM IMPROVEMENT MODIFICATION16

2942 TEST STATION INTERCONNECT (BUSSEL BOX) PARTS BREAKDOWN17

CG551AP TO CG5001 CONVERSION KIT

Serial Numbers Affected: All

CG551AP's can be converted to CG5001's for use in a TM5000 mainframe by installing kit P/N 040-1041-00.

W² Issue 12-18

C50 SERIES CAMERA SHUTTER TIMING

To improve shutter timing, the values of R21, R22 and R23 have been changed and are now selectable. Larger than nominal value will make the shutter timing longer and smaller than nominal value will make the timing shorter. Selection range should be within +500Ω of the nominal value.

	<u>New Nominal Value</u>	<u>P/N</u>	<u>Shutter Speed</u>
R21	3.01K	321-0239-00	1/60
R22	2.67K	321-0234-00	1/30
R23	5.11K	321-0261-00	1/15

Due to interaction the 1/60 speed resistor (R21) should be selected first.

W² Issue 12-19

DC510/DC5010 INCORRECT COUNTING ABOVE 300 MHZ

Serial Numbers:

- DC510 - B020200 and below
- DC510 Opt. 1 - B020240 and below
- DC5010 - B020550 and below
- DC5010 Opt. 1 - B020640 and below

Reference: Mod 47418, Schematics 2 and 3

Problems with ECL IC's, P/N 156-1032-00, will cause the counters not to work properly above 300 MHz. A new part number, 156-1032-04 which is a Hitachi only i.c., has been

W² Issue 12-18

set up for U1001 and U1110. If U1001 or U1110 fails or the counter will not meet specifications and U1001 or U1110 is replaced, check that U1001 and U1110 are both the -04 part. This new part will ensure correct operation of the counter when both U1001 and U1110 are the -04 part. There must not be a mismatch of the -04 part combined with the -00 part.

The following changes must be made when adding the new parts:

1. Ensure U1110 pins 9 and 10 are shorted together and pins 21 and 22 are shorted together. Remove A12C1502.
2. Add A12C1111 P/N 283-0220-00 .01microfarad between A12R1112 and A12R1113 as shown on the diagram.
3. Add A12C1141 P/N 283-0315-00 in series with pin 17 of U1110.
4. Add A12R1141 P/N 317-0102-00 from the junction of pin 17 of U1110 and A12C1141 to R1113 as shown in the diagram.
5. Add A12R1142 P/N 311-0644-00 to U1110 with the wiper connected to pin 17 and the other leads connected one to the junction of pin 9 and 10, and the other lead connected to the junction of pin 21 and 22.
6. Add A12R1143 P/N 311-2102-00. The wiper lead connects to the empty hole next to the anode of CR1111 (see diagram) and connect the other two leads to C1114, one on each side.

(ARTICLE CONTINUED ON THE NEXT PAGE)

DC510/DC5010 INCORRECT COUNTING ABOVE 300 MHZ (cont.)

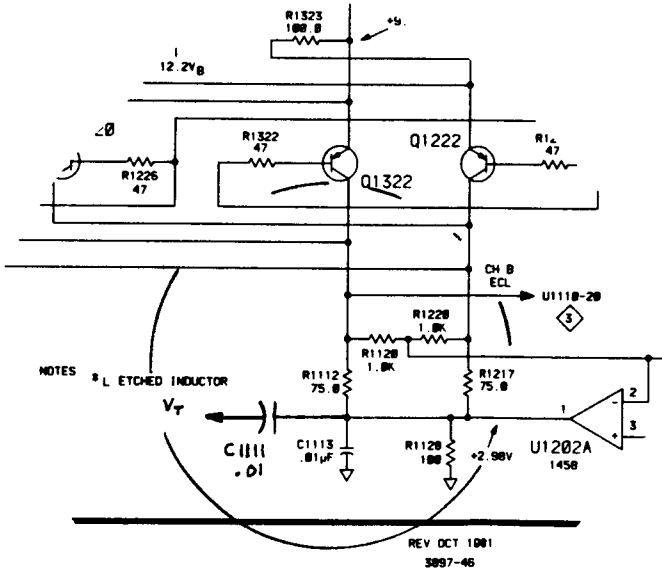

2

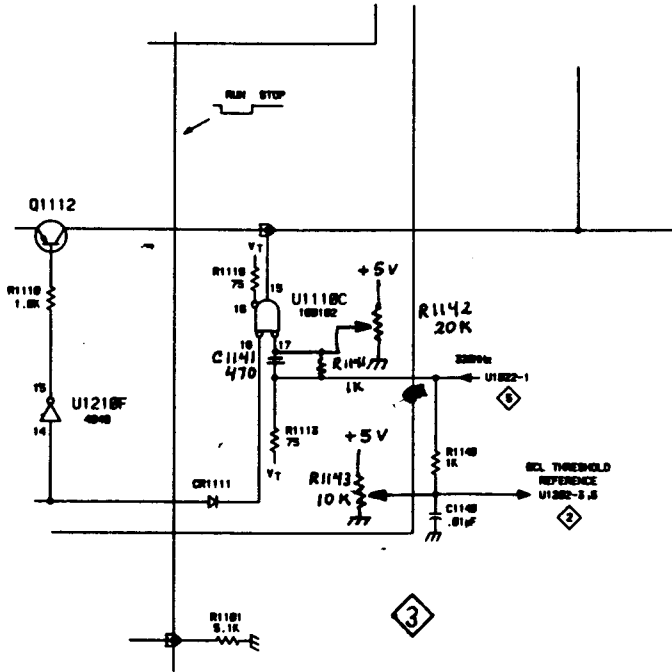

3

After the modification the following procedure is used for calibration. Adjust R1142 and R1143, ECL Threshold Reference Level. This procedure should only be performed if U1000, U1001, U1011, U1022, or U1110 have been replaced).

CHANNEL A and CHANNEL B
 TERM 50ohm
 ATTN X1
 SLOPE +
 COUPLING DC

1. Pre-set both variable resistors to mid-range (R1142 and R1143).
2. Set the DC510/DC5010 to TIME MAN.
3. Push MEASUREMENT START/STOP in.
4. ADJUST-R1142 until the instrument counts.
5. Connect a coaxial cable from the 1 MHz frequency standard output to the DC510/DC5010 CHANNEL A input. Adjust for a 100 mV signal.
6. Go to FREQ A mode and push in AUTO TRIG.
7. Check that the instrument counts correctly. Note that R1143 may need adjustment for proper counting. Remove the coaxial cable.
8. Connect a coaxial cable and X10 attenuator from the Signal Generator (SG504) to the CHANNEL A input.
9. Adjust the Signal Generator for a 350 MHz, 70mV peak-peak signal.
10. ADJUST-R1143 clock-wise and counter-clock-wise; noting the two extremes where the instrument still counts. Center R1143 between the extremes in that range.
11. Repeat the procedure of part j.; except for R1142.
12. Go to RATIO B/A mode.
13. Move the coaxial cable to the CHANNEL B input.

(ARTICLE CONTINUED ON THE NEXT PAGE)

DC510/DC5010 INCORRECT COUNTING ABOVE 300 MHZ (cont.)

14. Connect a coaxial cable from a second signal generator (SG503) to the CHANNEL A input.

15. Adjust the signal generator for a 10MHz, 1V(RMS) signal, and push in AUTO TRIG.

16. ADJUST-R1143 (staying within the set range) to get a correct and stable readout display.

NOTE: R1142 and R1143 will effect almost all parameters of the counter. After adjustment check the counter operation in all areas.

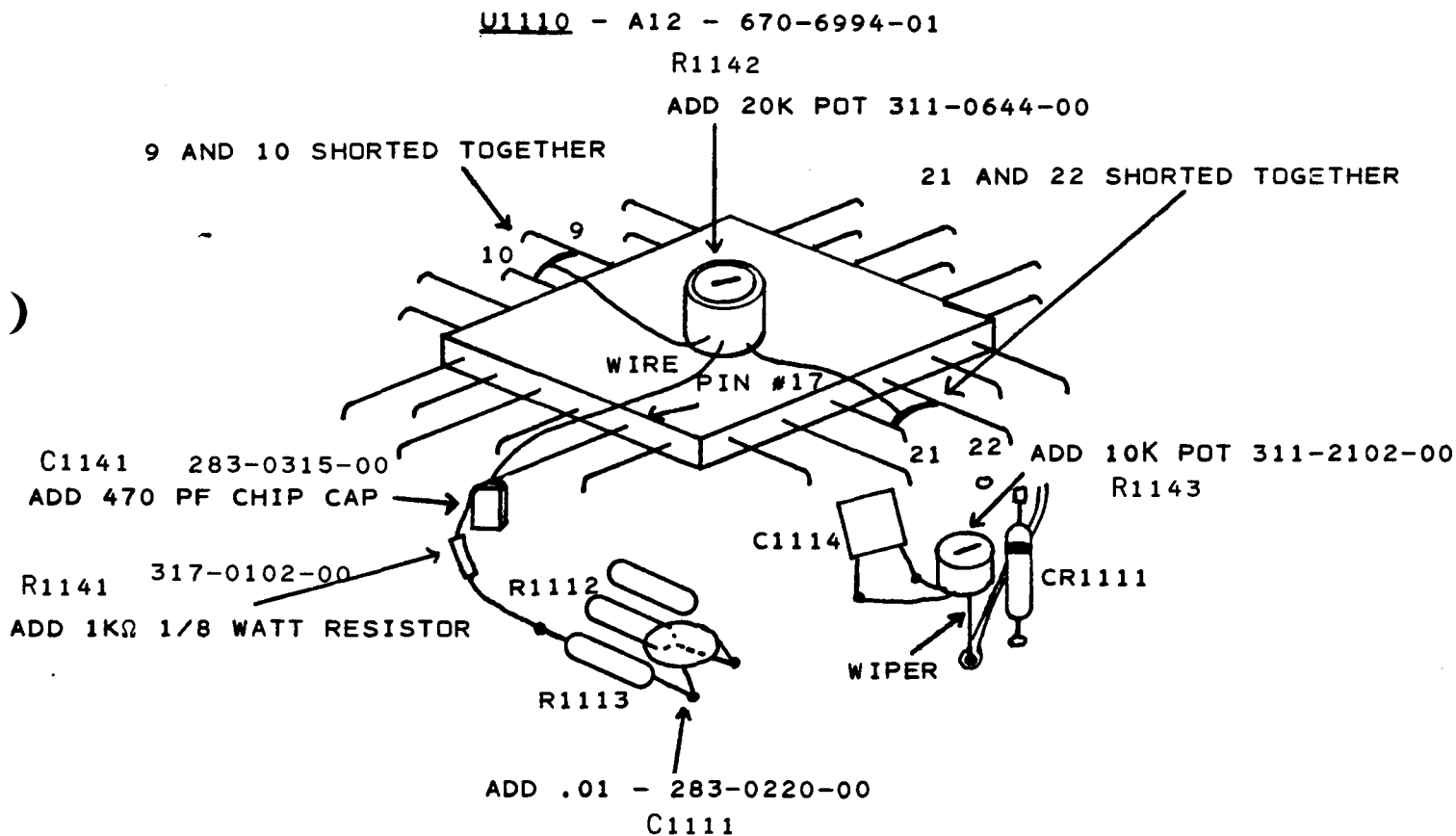

LIFT PIN #17 OF U1110 AND SOLDER 470 PF CHIP CAP (USING SILVER SOLDER) BETWEEN PIN #17 AND THE PAD ON THE BOARD.

DM5010 VOLTAGE READING CHANGE ON 1000 VOLT AC RANGE

Serial Number: B010710 and below

Reference: Schematic 3 RMS-Ohms input, Pilot Change 21

A16R1603 changes from a 2 meg ohm, 500V resistor to P/N 325-0385-00, a 2 meg ohm, 1000V resistor. The old resistor will change in value when subjected to 1000 volts. Even though the final value of the old resistor will stabilize, Manufacturing is changing to the new part number. The AC voltage range will have to be recalibrated after changing to the new part.

W² Issue 12-18

PARTS NEEDED TO CONVERT 1900 to R1900

<u>Part Number</u>	<u>Quantity</u>	<u>Description</u>
351-0636-00	1 Set	Rackmount Hardware
105-0786-01	2	Latch Cover
105-0787-00	2	Latch
212-0008-00	4	Screw 8-32x.5"
210-0008-00	4	Lock Washer
210-1018-00	2	Flat Washer
367-0264-01	1	Handle, Right
212-0559-00	4	Screw 10-32x.375"
210-1300-00	4	Flat Washer
351-0104-03	1 Set	Rack Slide
367-0263-01	1	Handle, Left

W² Issue 12-16

P7001: FIRST AND LAST BIT OF WAVEFORM DATA MAY BE DISPLACED VERTICALLY

REFERENCE: Manual 070-1599-00, page 2-4.

SYMPTOM: The first and last elements of a waveform array which has been acquired from a P7001 may contain erroneous data.

PROBLEM: The source of the erroneous data is briefly explained in the DPO Operators Manual (070-1599-00) on page 2-4; however, the last sentence of the second paragraph is in error. It should read: "The end points (0 and 511) should be considered invalid for measurement purposes."

SOLUTION: Generate a software routine which will predict the logical value of the first and last element of the waveform array, for example: First: A(1)=A(2)+(A(2)-A(3)) Last: A(1024)=A(1023)+(A(1023)-A(1022))

A routine of this type will introduce minimum error while maintaining a power-of-2 array size.

W² Issue 12-16

SC502/SC504 HALO SUPPRESSION CRT MOD KIT

Reference: M44232, M44233, P/N 154-0859-00

P/N 050-1601-00 is the mod kit which is used when replacing the CRT in SC502 and SC504. The old CRT P/N 154-0730-05 is no longer available.

W² Issue 12-17

SPG 1/2, 11/12 MODIFICATION

Reference: SPG 1/2 Manual 070-2104-00
SPG 11/12 Manual 070-2324-00
Mod M45165

Mod 45165 addresses two problems in the SPG Series.

(ARTICLE CONTINUED ON THE NEXT PAGE)

SPG 1/2, 11/12 MODIFICATION (cont.)

1) Due to a spacing problem between the Pulse Output board and the Sync Lock board, there were occasions where C848 (Pulse Output Board) could contact U329 (Sync Lock Board), thereby putting a +15 volt potential into U848 and several IC's, often destroying them. To remedy this problem, the socket under U329 has been removed, thereby allowing sufficient spacing.

2) Under certain conditions of SC/H phase, the SPG would not lock up immediately to an incoming signal upon power up. C279 has been made test selectable to solve this problem. The selection range is 0-200pf; nominal value 0pf (no cap installed).

W² Issue 12-17

S-3200 CLOCK PHASE SIGNAL SPLITTERS, MODIFIED - M45960

The Phase Splitters 015-0245-00 and 015-0246-00 have been made more reliable. Modification M45960 calls for replacing the set screws (213-0075-00) with a longer type (213-0022-00). Lock washers (210-0012-00) are also added behind the BNC connectors.

W² Issue 12-17

S-3200 VERDICT F050

Running F050 verdict test on a good system without an I/O short will result in the test passing starting at the 1mA reading. To understand why, refer to the Data Flow and Reed-Switch Manual, P/N 062-3397-01, the sector card manual for your system and the verdict program T1SI. A correction to the verdict manual is needed in the drawing of the test signal path. Contacts between OM and IM need to be drawn in as shown in Fig. 1.

Fig. 1

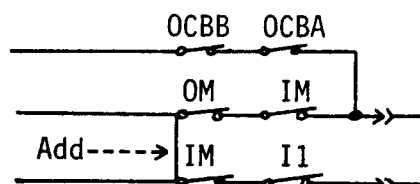

With the statement "Setup to force current on INS (Pin) from IS1"; reads I1 and IM close as well as channel 2 of the 50 ohm matrix to IS1. With the statement "Setup to measure current on Outs (Pin) from VS3" the following happens. From 1 A to 900 A the setup statement causes OCBA and OCBB reeds to close and O1 and OM are open. Without an I/O short the current path is broken and a failure will result. On the setup to measure statement starting at 1mA the reed O1 and OM close. This results in a current path through reed O1 and OM to OCBA and OCBB reeds then through the common bus to the DC subsystem. The current path allows the test to pass if everything in the system is good even if there is no I/O short on the sector card.

W² Issue 12-16

S-3200 VERSION 4.2 AND 4.3 SOFTWARE

The latest version of TekTest III Software is Version 4. If the system has RK05 disk drives then the operating system will be Version 4.2X. If the system has RL02 drives then the operating system will be Version 4.3X. The suffix versions will be alpha characters and at the time of this writing, the current versions are 4.2B and 4.3B. Version 4.3 also has the ability to use RL02 disk drives. Customers wishing to add RL02 disk drives must purchase BOTH the drive and the software. The sale of this software also

(ARTICLE CONTINUED ON THE NEXT PAGE)

S-3200 VERSION 4.2 AND 4.3 SOFTWARE
(cont.)

means that a new software license agreement must be signed. For this reason any customer who wants to use Version 4 with RL02 drives must place an order through their sales engineer.

TekTest III, starting with Version 4.2A and 4.3A have the ability to work with RS232 terminals. Prior to version 4.2A and 4.3A terminals having only RS232 interfaces could only be operated as a remote terminal. This will change some of the control keys that user's are familiar with. Most RS232 terminals issue an X ON (^Q) for Ready (screen cleared) and X OFF (^S) for Busy (screen full). This may cause some concern for some users. Control S (^S) has been used by TekTest for years as a means of stopping the computer program without exiting to the executive mode. A control S key stroke will now stop transmission of data to and from the terminal. If an operator presses Control S and is not aware of what to expect, they may then try Control C expecting to exit to the executive controller. The next concern will be that nothing is happening. It would appear that the computer has hung up. When in reality the terminal interface and software will only recognize Control Q (ready). In place of Control S TekTest now recognizes Control D. In TCM Control Q has been replaced by Control B.

Another feature of version 4.2 and 4.3 is that the system will now recognize lower case character commands. It will convert lower case characters to upper case unless the terminal attributes word is set; this is done with the OPTION program.

The Option program assists the user and service personnel in modifying the system terminal and line printer configuration. Information used by Options are interface address, interface vector, graphic (yes or no), software delay (yes or no), and upper-lower case control (yes or no).

The next update of version 4 will contain the Reboot command.

Reboot is very similar to the software boot routine that is used with RK05. The difference being that BOOT.RUN used by many is not a supportable piece of software. Reboot is a supportable software package.

Version 4.3 software contains DKCOPY. This program allows copying of RK05 to RK05 as well as RL02 to RL02. It will not allow RL02 to RK05 or RK05 to RL02 copying. However, when DK is specified, the virtual name is assumed and the transfers are made to the RK05 images regardless of the physical device, RK05 or RL02 Disk Drives:

It is worth mentioning the RL02 disk drive. The RL02 appears to the system as four RK05's. Each RK05 image contains its own Directory, Free list, and RK05 boot code. It can also contain the operating system on each RK05 image. TekTest drives or images at any given time. RK05 and RL02 drives can be used in the system together. All drives are accessed by their virtual names DKO through DK7.

Booting RL02:

When booting with RL02 the system will boot to the RL# entered from the terminal. On the RL02 there is a RL boot code. This code tells the system which RK05 image to boot up on. The RL boot code is controlled by the DLBOOT command. DLBOOT allows the operator to change the code on the disk to boot to the RK05 image desired. When the system boots to the RL02, it will boot to the RK05 image specified by the RL boot code.

W² Issue 12-18

S-3200 2942 INSTRUCTION DECODE
CARD MODIFICATION M46824

The Instruction Decode Card Assembly (700-7641-12) is modified by adding .083 feet of electrical 30 AWG wire (175-0929-00) between Pin 4 and Pin 12 of U8 on Module 2.

(ARTICLE CONTINUED ON THE NEXT PAGE)

S-3200 2942 INSTRUCTION DECODE CARD
MODIFICATION M46824 (cont.)

Make the wiring change and also correct the diagram shown on Diamond 12 in the 2942 Programmable Pattern Generator Manual (070-3193-00). The Pattern Generator was recognizing Set 'D' instructions when a LOAD command was issued. This change will prevent the Pattern Generator from recognizing the LOAD command as an Instruction Command which could send erroneous data to the DUT. The circuit board assembly part number revision level will not change, however, all production boards will include the modification.

W² Issue 12-16

TSG 13 SYNC AMPLITUDE

Reference: TSG 13 Manual 070-2330-00
Mod 44527

Calibration of master gain is addressed in the product manual in Step 1. Electrical design defines the sync amplitude as a portion of the signal affected by master gain, and is not separately adjustable. As a result, sync amplitude has been at the top end of its spec (40IRE, ±1%).

If sync specs cannot be met, Mod 44527 readjusts this total signal to sync ratio.

Remove R279 (Linearity Board, A40) and replace it with a parallel combo consisting of R279 (321-1705-04, 13.05Kohm, 1%) and R289 (321-0417-00, 215Kohm, 1%).

W² Issue 12-17

WEIGHTING FILTERS FOR THE 380

As you know, the tangential noise measurement on the 380 test monitor is unweighted or at least only limited by its bandwidth. Customers who wish a weighted

noise measurement can do so by applying external filters. There are two methods of applying external filters:

1. Cascade the chosen filters directly into the LOOP THRU input. This procedure subjects the signal feed to the poor return loss of the filters and requires proper isolation from the program line.
2. Connect the signal to be measured to LOOP THRU input, select the LOOP THRU for the signal output (Using the side panel switch), cascade the filters between the SIGNAL OUTPUT and the PROBE input, and use a feed-thru termination on the PROBE input. This provides complete isolation from the program line.

For those customers that want to make weighted noise measurements and don't already have weighting filters, you should advise them that CCIR recommendation 568 provides for measuring signal-to-weighted random noise on all international transmissions (both 525/60 and 625/50) with a 5.0MHz low pass filter and a unified noise weighting filter.

Low Pass 5.0MHz	015-0213-00
Unified Noise Weighting	015-0283-00

The NTC report number seven (3.16 random noise weighted) recommends the use of a 4.2MHz low pass filter, a noise weighting filter, and a 10KHz high pass filter.

Low Pass 4.2MHz	015-0214-00
Noise Weighting Filter	015-0212-00

A 10KHz high pass filter for coherent and random noise can be simulated by viewing the signal in the line select mode. Noncoherent, periodic and non-locked cross talk noise will not be filtered.

W² Issue 12-16

19" AND 25" DVST DISPLAYS PIN 35 NAME CHANGED

A 36 pin analog interface connector is found on the back panel of the 618, 619, 618 Mod DM and Option 34 versions of the GMA101A, GMA102A, GMA103 and GMA125. Pin 35 of this connector is variously called DIGITAL GROUND, TTL GROUND and PROGRAM GROUND. This has caused some confusion as this pin is not always a ground.

Pin 35 is used to tell the 067-0807-00 Display Exerciser whether it is connected to a 19" display or a 25" display. A ground on pin 35 indicates a 19" display and an open indicates a 25" display (the 067-0807-00 has a pull up resistor on this line). The exerciser then produces the appropriate pattern.

To better reflect its purpose, the name for pin 35 is being changed to DISPLAY SIZE on all the above mentioned 19" and 25" DVST displays. This change is being made in all affected Service manuals.

W² Issue 12-17

69MXX SERIES THUMB LATCHES

Reference: Mod 45940

The plug-in interface modules for the 690SR (69M00, 69M01, 69M10, 69M41) now call for new rear latches that are UL recognized. These latches replace the thumb latch with a screwdriver latch. The new latch is P/N 214-3161-01.

W² Issue 12-17

69M00/69M01/69M10 HORIZONTAL JITTER

Reference: 69M00 Manual 070-3657-00
69M01 Manual 070-3743-00
69M10 Manual 070-3744-00
Mod 47516

In 690SR monitors equipped with one of the above 69M Series plug-in interface modules, excessive horizontal jitter occurring while in the Horizontal Shift mode can be reduced by changing U539 (AFC board) to a 156-1195-01.

W² Issue 12-17

147A/149A CABLE HARNESSES

Reference: 147A/149A Manual
P/N 070-2029-00

A recent request from the field for part numbers for the individual wires of a cable harness brought up a problem that is not obvious to anyone doing a similar replacement. The request was for the coaxial cables that are a subpart of a cable harness, 179-1850-01.

In this cable assembly there are two types of coaxial cable used, 50 ohm and 75 ohm. From the outside, these cables are virtually identical--both types are white. It is *very important*, however, that the proper cable be used in the appropriate location to maintain desired electrical specifications, especially return loss.

If these cables are to be replaced, the following part numbers apply. NOTE: This is for bulk wire; specify lengths required when ordering (i.e. feet, yards, etc.).

175-1020-00	50 ohm Coaxial Cable
175-1087-00	75 ohm Coaxial Cable

To help you determine which type of wire to order, the "rule of thumb" is to look at the center conductor. A center conductor of silver colored stranded wire will be 50 ohm, while the 75 ohm type will have a solid conductor that is gold in color.

(ARTICLE CONTINUED ON THE NEXT PAGE)

147A/149A CABLE HARNESSSES (cont.)

NOTE: This "rule" only applies to the small (about 1/8") coaxial cable with the white outer jacket. Other sizes and colors will be different. Contact Service Support if you have any questions as to the particular cable you are replacing.

Also, it is not only important to replace the cable with one having the correct impedance. The new cable must be as close in overall length as the cable removed, to maintain return loss.

In new product manuals, we will endeavor to get accurate, and useful, cable diagrams. As far as older instruments are concerned, I will handle them on a case-by-case basis as required.

W² Issue 12-19

149A POWER SUPPLY

Reference: 147A/149A Manual
070-2029-00

For troubleshooting purposes, the nominal power supply currents for the 149A are as follows:

-15V	870 mA
+15V	500 mA
+5V	1.6 A

W² Issue 12-18

149A VIR DETECTOR TEMP STABILITY

Reference: 149A Instruction Manual
070-2029-00
Mod 46222

The VIR detector circuitry may exhibit intermittent ability to consistently recognize the presence of incoming VIR on the program line. This problem can be aggravated by elevated temperatures within the instrument.

A possible cause is C472 having too wide of a tolerance range, and therefore causing failures while still being a "good" component. The solution is to replace C472 with a 283-0238-00 (.01 μ fd, 10%, 50V) capacitor.

W² Issue 12-17

492/P SHAPE FACTOR SPECIFICATION CHANGE

RE: 492/P OPERATORS MANUAL
(P/N 070-2726-03).
492/P SERVICE VOL. # 1 S/N B03
& BELOW (P/N 070-2727-03)
492/P SERV. VOL. #1 S/N B03
& UP (P/N 070-3783-01)

Please change the Resolution specification on table 1-5 of the option 3 Electrical characteristics to read.

Performance Requirement

Additional resolution bandwidth of 100 Hz with 7.5:1 shape factor except instruments prior to B040000 that have the cavity 2nd LO A20, Part # 119-1022-00, 01 and 02. Shape factor for these instruments with 100 Hz resolution is 15:1.

W² Issue 12-15

492/P V.R. CIRCUIT BOARD REPLACEMENT KIT

RE: 492 S/N B020000 - B042199

This Parts Replacement Kit (P/N 050-1620-00) provides parts and instructions to replace circuit boards or assemblies as follows:

1. A69A1 #1 V.R. Mother circuit board, pn 670-5528-02, replaces #1 V.R. Mother circuit board, pn 670-5528-01.

(ARTICLE CONTINUED ON THE NEXT PAGE)

492/P V.R. CIRCUIT BOARD REPLACEMENT
KIT (cont.)

2. A69A3 1st Filter Select circuit board, pn 670-5530-03, replaces 1st Filter Select circuit boards, pn 670-5530-01, and 670-5530-02.
3. A69A4 10DB Gain Steps circuit board, pn 670-5531-04, replaces 10DB Gain Steps circuit board, pn 670-5531-02.
4. A69A5 20DB Gain Steps circuit board, pn 670-5532-03, replaces 20DB Gain Steps circuit board, pn 670-5532-02.
5. A68A2 2nd Filter Select circuit board, pn 670-5534-04, replaces 2nd Filter Select circuit board, pn 670-5534-01, 670-5534-02, and 670-5534-03.
6. A68A1 #2 V.R. Mother circuit board, pn 670-5536-02 replaces #2 V.R. Mother circuit board, pn 670-5536-01.
7. Variable Resolution Module #1 A69, pn 644-0140-02, replaces Variable Resolution Module #1 pn 644-0140-01.
8. Variable Resolution Module #2, pn 644-0141-02, replaces Variable Resolution Module #2, pn 644-0141-01.

NOTE

If the serial number of your Spectrum Analyzer is above those listed, or if this Parts Replacement kit or Parts Replacement kit, pn 050-1466-01, or 050-1467-01, has been installed, disregard the instructions and use the circuit board or V.R. assemblies listed above as direct replacements.

W² Issue 12-15

492/P, 496/P - A58U4305 REPLACEMENT
KIT

Re: 492 S/N B010100 - B031419
492/P S/N B010100 - B041659
496 S/N B010100 - B010110
496P S/N B010100 - B010110
M42650, M43249

The 050-1528-00 Parts Replacement Kit contains a Microcircuit, P/N 156-1086-00, a 220pF capacitor and a dummy resistor, which are required to replace U4035 to assure that the clock oscillator for the Processor will start at the correct frequency.

W² Issue 12-15

496/P AND 492/6 MIXER DIODE A12A1 ---
PART NUMBER INCORRECT

It has just been brought to our attention that the part number noted in the 496/P and 492/6 manuals for A12A1, Mixer Diode, is incorrect. Instead of the 155-0189-01 number listed, you should use part number 155-0232-01. Please correct all documentation immediately to show the correct part number, 155-0232-01.

The 496/P and 492/6 do not have an input limiter so the mixer diode will be easily damaged if the wrong part is installed. The 492/P uses the 155-0189-01 so the 492/P manuals are correct.

W² Issue 12-15

4006-1/4051/4052 HARD COPY NOISE MOD
#47967

REF: 4006-1 Service Manual 070-1892-01

4051 Service Manuals Vol 1
070-2065-01 Vol 2 070-2286-02

4052 Service Manuals 070-2829-01
070-2840-02

Information from our field technicians indicates some difficulties in obtaining good hard copies after a CRT or Display board has been replaced. This article is to inform the field of a modification and to review other items which will help obtain that good copy.

Modification 47967 eliminates a high voltage oscillation on the ground runs of the Display boards (672-0537-10 -- 4006-1, 672-0546-10 -- 4051/52). This oscillation caused hard copy noise and distorted the display. The modification consists of the following:

- 1) Connect a wire on the back of the board between J54 pin 7 and J55 pins 2 and 3.
- 2) Roll the Display boards to -11.

Other items can cause hard copy noise. The known ones are as follows:

- 1) Wizards Workshop article "4006-1/4051 Hard Copy Noise Problems" in issue 7-03 page 10 deals with a ground loop caused by the high voltage magnetic field. It involves Q432, C147, and R433 on the Display board.
- 2) The cable from J58 of the Display board to the CRT should be inserted into the mu-metal shield (toward the CRT) as far as possible. This provides the least amount of "antenna" to pick up high voltage radiations on the Op Level (this is the signal the Tarsig board reads).

- 3) On the Display board heatsink, all screws attaching the PCB to the heatsink should be installed and tight. Some of these screws connect chassis ground of the PCB to the terminals chassis.
- 4) The High Voltage shield should have all its attaching screws in and tight for good high voltage noise radiation grounding.
- 5) Last, but important, be sure the light filter's ground clips are in place and making good contact.

W² Issue 12-17

4014/14-1, 4015/15-1, 4016-1 JACKSCREWS
ADDENDUM

References: Wizards Article, Issue
12-10, page 12 --
"4014/14-1, 4015/15-1,
4016-1 Jackscrews."

4014/14-1, 4015/15-1 Ser-
vice Manual 070-2303-00

4016-1 Service Manual
070-2661-00

It has been brought to my attention that some are interpreting the above referenced article to include the 4014, 4015 internal display cable (p.n. 179-2248-03). This is not true, jackscrews should only be in the "desk-mount" cable that allows separating the Display from the Pedestal. Do NOT use these jackscrews to mechanically hold the Display to the Pedestal. There are other screws used along the front and back edges of the Pedestal-Display mounting plate. Please see installation instructions in the applicable Service manuals.

W² Issue 12-16

4016-1 SMALLEST CHARACTERS LINE SPACING VARIES

References: 4016-1 Service Manual
070-2661-00
Corporate Mod M43769

When the smallest character size is printed on the 4016-1 screen, the line spacing between lines will vary. A modification has been written and implemented to correct this abnormality. The modification is as follows:

1. On the 670-5811-02 (TC-1) board cut and lift pin 5 of U115B.
2. Solder a length of brown teflon coated wire (p.n. 175-0639-00) to the lifted pin.
3. Attach the other end of the wire (cut to the shortest possible length) to pin 9 of U321.
4. Roll board level to -03.

This modification became effective with serial number B061160 on the 4016-1.

W² Issue 12-16

4023 DISPLAY -- HORIZONTAL ADJUSTMENTS

Raster width and Horizontal linearity are affected by a combination of the low voltage supply, width coil L101 and the horizontal linearity sleeve located on the neck of the CRT beneath the yoke (see drawing below).

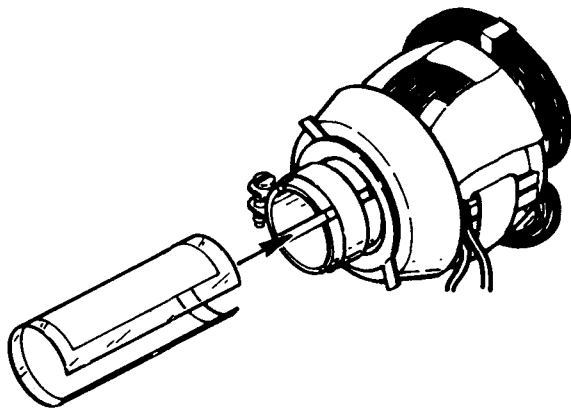

The following is a procedure for these adjustments.

1. Loosen the clamp screw on the yoke assembly.
2. Apply power and fill the screen with characters.
3. Adjust the horizontal linearity sleeve so that about 2/3 of its length is under the yoke.
4. Adjust the horizontal width coil, L101, for the desired width.
5. Insert the linearity sleeve farther under the yoke to obtain the best linearity. Although this adjustment will affect the raster width, it should not be used solely for that purpose.
6. Readjust L101 for proper width.
7. Observe final horizontal linearity and width, and touch up either adjustment if needed.
8. Tighten the yoke clamp screw.

If these adjustments do not give proper width or good linearity; as good or better than the previous part, I would suspect a defective replacement part.

W² Issue 12-16

604A CRT PART NUMBERS REVERSED

The part numbers of the standard and option 1 cathode ray tubes (V735) were inadvertently reversed in the latest printing of the 604A Service Manual, 070-2540-00. The standard CRT is part number 154-0674-05, and the option 1 CRT (internal graticule) is 154-0633-05.

W² Issue 12-17

650HR SERIES MODIFICATION

Reference 650HR Manual 070-2646-00
 Mod 43680
 Mod 45414

Mod 43680 introduced a new CRT to the 650HR series that is capable of higher resolution and has a slight phosphor color change, more closely matching EBU requirements. Mod 45414 changes various parts in several areas to take advantage of the capabilities of the new tube. The areas affected are:

<u>ECB</u>	<u>New Part Number</u>
Blanking	670-1603-05
Aperature	670-5032-02
NTSC Decoder	670-2611-11
(NTSC Instruments Only)	
Aperature Correction	670-4964-06
EHT	119-0320-08

This major modification occurred at about Serial Number B050000.

In a 650HR previous to B050000, where CRT replacement is necessary, it is not necessary to change the affected boards. However, if you use the new CRT (154-0858-00), the following numbers will allow proper colorimetry settings for the new tube. (Use the X10 setting on your J16.)

	<u>RED</u>	<u>GREEN</u>	<u>BLUE</u>
10IRE	.30	.38	.24
100IRE	.58	.71	.46

The EHT (119-0320-08) is the new direct replacement part for all 650A/650HR units where a single anode lead is used. The dual lead EHT for older 650/650A units is 119-0320-05.

The remainder of the instrument is basically the same as pre-B05.

650HR SERIES RACK SLIDES

Reference: 650HR Manual 070-2646-00
 Mod 46726

Due to a change in rack slide design, a safety feature that prevented the instrument from being inadvertently pulled from the rack slides was defeated.

The spring latches have been modified to prevent the instrument from being pulled out too far and possibly dropped.

Replace each latch (214-2538-01) with a new part (214-2538-02) where this complaint exists.

W² Issue 12-18

690SR LINE RATE CHANGE

The Horiz deflection circuit of the 690SR has been designed to run at any rate from 15 kHz to 37.8 kHz. This range can be divided up into 5 overlapping operating ranges, reachable by appropriate programming:

<u>Horiz Freq Range</u>	<u>Horiz Active Time Range</u>
15.0 kHz--16.6 kHz	60 --53.4 s
16.6 kHz--19.8 kHz	53.4--43.8 s
19.8 kHz--25.8 kHz	43.8--32.0 s
15.8 kHz--31.4 kHz	32.0--25.1 s
31.4 kHz--37.5 kHz	25.1--20.0 s

For power conservation reasons, certain amplifiers in the 690 are run at lower rates. When a change is being made to either of the highest 2 ranges, it will be necessary to increase the B+ supply to these amplifiers. This will be done with internal jumpers according to the chart below.

Convergence Output - Board A14A1, P853
 Pins 1 and 2 for hi rate (35V)
 Pins 2 and 3 for lo rate (15V)

W² Issue 12-18

(ARTICLE CONTINUED ON THE NEXT PAGE)

690SR LINE RATE CHANGE (cont.)

Vertical Deflection - Board A10A1, P542

- Pins 1 and 2 for hi rate (35V)
- Pins 2 and 3 for lo rate (15V)

Horiz Deflection - Board A11A1, P720

- pins 1 and 2 for lo rate (80V)
- Pins 2 and 4 for med rate (120V)
- Pins 2 and 3 for hi rate (200V)

In addition to the above 3 jumpers, "S" cap selection will be made on the Horizontal Delay Stabilizer board, A11A2, with H105, 205, 405 and 505 in accordance with the chart below.

Selection of the proper size "S" cap with jumpers J105, 205, 405 and 505 ensure display linearity for a given horiz scan rate range. The affect of the "S" cap changes with the rate of the horiz sweep. The faster the sweep rate, the smaller the capacitance required to produce a linear display.

Any of all of the below can be placed in parallel with an existing "S" cap already in the circuit to ensure display linearity.

	15.0 to 16.6kHz	16.6 to 19.8kHz	19.8 to 25.8kHz
J105	X	X	X
J205	X	X	X
J405	I	0	I
J505	I	I	0

	25.8 to 31.4kHz	31.5 to 37.5kHz
J105	X	X
J205	I	0
J405	0	0
J505	0	0

- X = Determined During Cal
- 0 = Jumper to left
- I = Jumper to right

- J105 Controls "S" cap A, 0.15 f
- J205 Controls "S" cap B, 0.35 f
- J405 Controls "S" cap C, 0.82 f
- J505 Controls "S" cap D, 1.84 f

As can be seen, J105 and J205 control caps small in size compared to J405 and J505. In the above chart where X's appear, a noticeable change probably won't be detachable without the use of a linearity graticule regardless of what position the jumper is in.

W² Issue 12-16

690SR/6942 VIDEO AMP VMOS FETS

RE: 690SR MANUAL, 070-3821-00
MOD 47840

In order to get a better yield from some VMOS parts, they will be purchased with a 4.2 Vgs spec. The new part number for Q291, Q491 and Q691 will be 151-1143-01.

In order to have the circuit biased properly for these parts, a 1.4K Resistor (P/N 323-0207-00) needs to be added to each channel as shown in the figure below (Green channel shown).

A kit has been set up to accomplish this change when one of the affected transistors needs to be replaced. 050-1674-00 will supply one transistor to replace the failed part and three resistors to put into the circuit, one for each channel (Red, Green and Blue). Kit 050-1674-00 need only be ordered where a previous kit, 050-1582-00, has already been installed. Of course, once 050-1674-00 has been installed, you need order only the failed transistor replacement for that channel.

(ARTICLE CONTINUED ON THE NEXT PAGE)

690SR/6942 VIDEO AMP VMOS FETS (cont.)

If kit 050-1582-00 has not been previously installed in the affected channel, you should order kit 050-1582-01. This kit contains the resistor necessary to make the changes needed for one transistor, plus other parts that were contained in the -00 version of the kit.

Note - unless 050-1582-00 has been installed in all channels, do not attempt to install the new resistor (1.4K) in the unmodified channels.

Any video amp boards, P/N 672-0875-03, will have these mods incorporated from the factory.

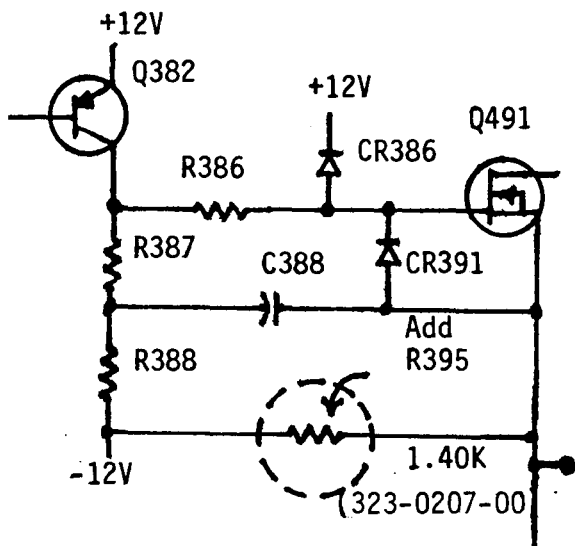

W² Issue 12-18

1420 SERIES

Reference: 1420 Manual 070-2032-00
Mod 45747

Due to the high probability of electrical shorts occurring because of the proximity fo the leads from the power switch and graticule lights to the chassis, it is recommended that heat-shrink tubing be added at these points. Use 162-0531-00 or 162-0561-00 tubing as necessary.

W² Issue 12-15

1440 I3B, 147, 149, 1900 - TELETEXT DATA

RE: 1440 I3B MANUAL INSERT,
061-1448-00

Very recently, NBC has started tests of Teletext transmissions on lines 15 and 16 of the vertical interval, and some problems have come up in relation to the applications where inserting equipment is used. In particular, the NBC affiliates have called several centers requesting information on how they might pass lines 15 and 16 without local deletion/regeneration.

On the 1440 Mod I3B, the vertical insertion timing is factory set to pass lines 17 and up by adjusting R7205 on the insertion timing board. In order to give this adjustment more range, it may be necessary to change R7200. A value of about 25K for R7200 will allow the vertical insertion timing to be adjusted to earlier than line 15, and thereby let lines 15 and 16 pass unaffected. (Consult the 1440 Mod I3B adjustment procedure, step 10g, and set R7205 so that the step blanking voltage occurs in line 13 or 14).

For the 147/149 and 1900 applications, insure that the generator is not programmed to put a signal on lines 15 or 16 and do not use the Delete mode (Rear panel connector).

W² Issue 12-18

1804 PRESSURE SWITCH S35

There are two pressure switches S35 referenced on Page 6-74 of the 1804 Test Stations, Volume 2, P/N 070-3331-01. The first switch referenced, P/N 260-1880-00, was replaced by the second switch referenced, P/N 260-2038-00. Any order for the old pressure switch will result in the newer switch being sent. Remove the listing for P/N 260-1880-00 from the manual.

W² Issue 12-19

1885 DUAL STATION MULTIPLEXER, A10
MODULE REDESIGNED, M44285

The A10 Module (670-6715-00) which is the Station Enable Buffer, was redesigned so that the Station Enabled line would go low only for the station being activated. The new circuit board, PN 670-6715-01, incorporates a Hex Buffer (156-0140-02) to buffer the lines from each station. After the Buffer the Station Enabled lines are wire "OR'd" as before the mod.

It is not recommended that this board be hand modified. The replacement 670-6715-01 is available through Tektronix.

W² Issue 12-17

1885 DUAL STATION MULTIPLEXER,
A60 MODULE REDESIGNED, M44991

The A60 Module, Dual Station Buffer Circuit Board Assembly P/N 670-6720-00, was redesigned to prevent crosstalk between the Test Station Control Unit Interface and the 1330 Test Station Master Control Unit. The replacement part number for the A60 Module, buffer number 6, is 670-6720-01.

W² Issue 12-17

1980 RACK SLIDE LATCHES

Reference: 1980 Service Manual
061-2290-00
Mod 46726

Due to a change in rack slide design, a safety feature that prevented the instrument from being inadvertently pulled from the rack slides was defeated.

The spring latch has been modified to prevent the instrument from being pulled out too far and possibly dropped.

Replace each latch (105-0833-00) with a new part (105-0833-01) where this complaint exists.

W² Issue 12-18

2213/2215 TRIGGER SYSTEM IMPROVEMENT
MODIFICATION

RE: P/N 040-1099-00
2213, SN B010100 - B025774
2215, SN B010100 - B025695
APPLICATION: AS REQUIRED,
ESPECIALLY USEFUL FOR TV
SIGNAL TRIGGERING

Mod kit 040-1099-00 is now orderable to improve the operation of the AUTO and TV FIELD trigger circuits. It improves triggering on Composite Video Sync pulses and on successive TV Fields in ALT mode. Holdoff time is reduced to decrease the trace flicker in ALT mode and increase display brightness.

W² Issue 12-19

2942 TEST STATION INTERCONNECT (BUSSEL BOX) PARTS BREAKDOWN

The following illustration is the replaceable parts for the Bussel box and interconnect cable. It is recommended that this page be inserted in the 2942 manual. On Figure 2 of the 2942 manual there is a blank page large enough to allow for this page.

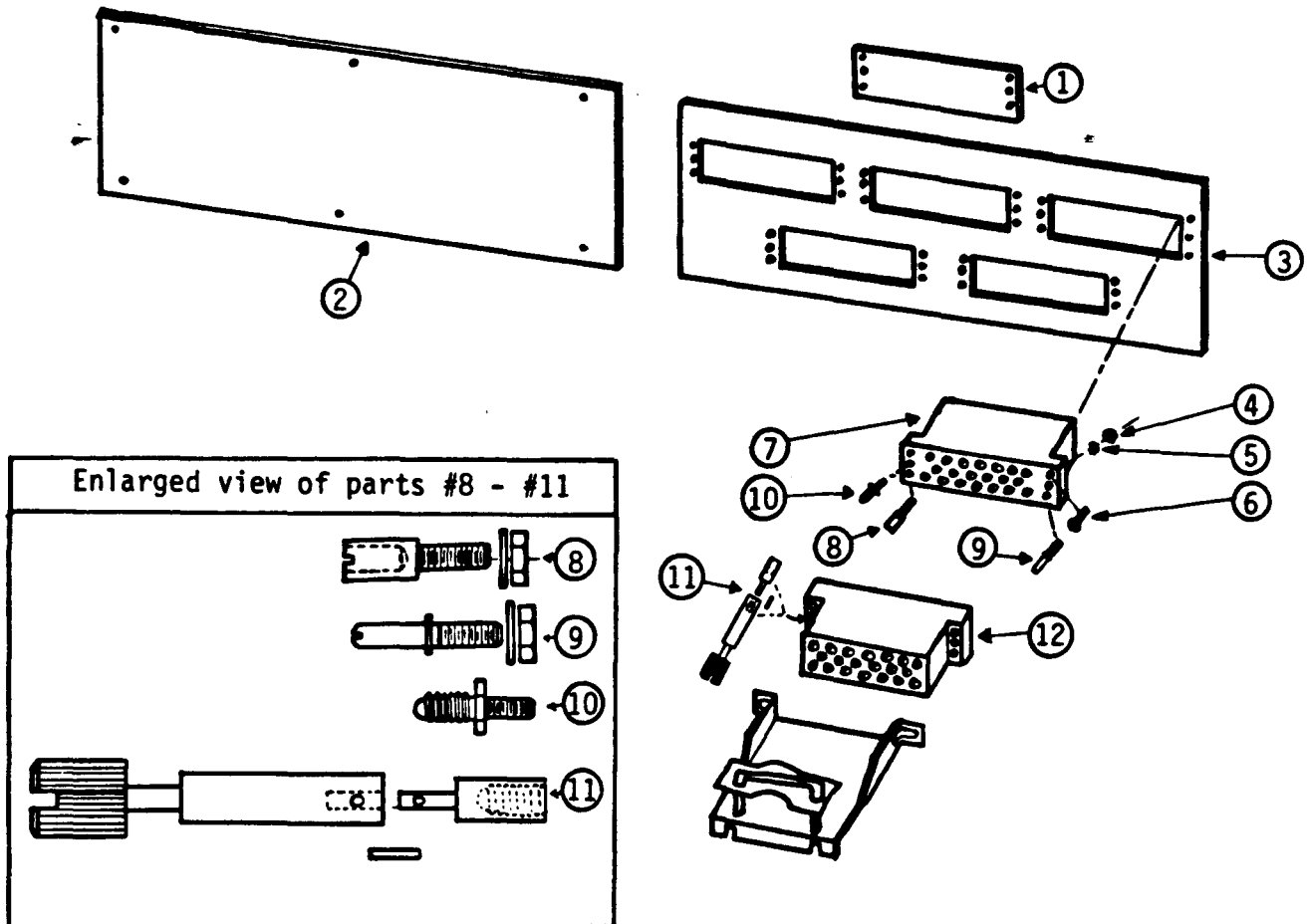

- | | | |
|----|-------------|--|
| 1 | 200-1791-00 | Plate, Connecting |
| 2 | 386-3235-00 | Plate, Connecting |
| 3 | 386-3320-00 | Plate, Connecting |
| 4 | 210-0406-00 | Nut, Hex |
| 5 | 210-0003-00 | Washer, Star Lock |
| 6 | 211-0013-00 | Screw, Machine |
| 7 | 204-0624-00 | Connector Body |
| 8 | 214-2169-00 | Pin, Guide Female |
| 9 | 214-2171-00 | Pin, Guide Male |
| 10 | 213-0488-00 | Jackscrew, Male |
| 11 | 213-0432-00 | Jackscrew, Female with Mixed Connector to Connector |
| 12 | 131-1753-00 | Connector Body |
| 13 | 380-0440-00 | (Not Shown) Bussel Box Frame |
| 14 | 200-1786-00 | (Not Shown) Bussel Box Top Cover |
| 15 | 003-0829-00 | Extraction Tool (Used to remove cables from Connector Body). |

The Tektronix Service Organization firmly supports a policy of assuring continued utility of products sold by Tektronix.

This publication is meant to provide technical information to the customer who has decided to maintain his own Tektronix products. It contains product servicing information and is written for the technician.

Articles are submitted primarily by Service Support Staff Engineers thoroughly familiar with the products they support. SERVICE TEKNOTES also encourages you, the user, to submit articles for publication. If you have knowledge of a technique, procedure or idea that enables you to service your Tektronix product more effectively, write it down so others may benefit from your experience.

Articles for publication should be submitted directly to:

Tektronix, Inc.
P.O. Box 500
Beaverton, Oregon 97077

Attention: Janet Hemenway
SERVICE TEKNOTES Editor
Delivery Station: 56-037

SERVICE TEKNOTES is distributed by Service Administrative Support free of charge to customers who maintain their own Tektronix equipment. A customer may be added to the distribution list by applying through his local Tektronix Sales Engineer.

Copyright ©1981, Tektronix, Inc. All rights reserved. Printed in U.S.A. Tektronix products are covered by U.S. and foreign patents, issued and pending. Information in this publication supersedes that in all previously published material. Specification and price change privileges reserved. TEKTRONIX, TEK, SCOPE-MOBILE, and  are registered trademarks of Tektronix, Inc. TELEQUIPMENT is a registered trademark of Tektronix U.K. Limited.

The Editor and staff of SERVICE TEKNOTES provide the material in this publication as a service to users of Tektronix Products. While we have tried to be diligent in assuring the accuracy of the material which we have printed, we cannot guarantee its accuracy. Neither SERVICE TEKNOTES, its editor and staff, Tektronix, Inc., nor its representatives assume any responsibility for the use of the material printed in SERVICE TEKNOTES; nor can we assume any responsibility for any errors or for the resulting effects of any errors.