

**User Manual**

**Tektronix**

**TAS 220 & TAS 250  
Analog Oscilloscopes**

**070-9186-02**

Copyright © Tektronix, Inc. 1994. All rights reserved.

Tektronix products are covered by U.S. and foreign patents, issued and pending. Information in this publication supercedes that in all previously published material. Specifications and price change privileges reserved.

Tektronix, Inc., P.O. Box 1000, Wilsonville, OR 97070-1000

TEKTRONIX and TEK are registered trademarks of Tektronix, Inc.

## WARRANTY

Tektronix warrants that this product will be free from defects in materials and workmanship for a period of one (1) year from the date of shipment. If any such product proves defective during this warranty period, Tektronix, at its option, either will repair the defective product without charge for parts and labor, or will provide a replacement in exchange for the defective product.

In order to obtain service under this warranty, Customer must notify Tektronix of the defect before the expiration of the warranty period and make suitable arrangements for the performance of service. Customer shall be responsible for packaging and shipping the defective product to the service center designated by Tektronix, with shipping charges prepaid. Tektronix shall pay for the return of the product to Customer if the shipment is to a location within the country in which the Tektronix service center is located. Customer shall be responsible for paying all shipping charges, duties, taxes, and any other charges for products returned to any other locations.

This warranty shall not apply to any defect, failure or damage caused by improper use or improper or inadequate maintenance and care. Tektronix shall not be obligated to furnish service under this warranty a) to repair damage resulting from attempts by personnel other than Tektronix representatives to install, repair or service the product; b) to repair damage resulting from improper use or connection to incompatible equipment; or c) to service a product that has been modified or integrated with other products when the effect of such modification or integration increases the time or difficulty of servicing the product.

**THIS WARRANTY IS GIVEN BY TEKTRONIX WITH RESPECT TO THIS PRODUCT IN LIEU OF ANY OTHER WARRANTIES, EXPRESSED OR IMPLIED. TEKTRONIX AND ITS VENDORS DISCLAIM ANY IMPLIED WARRANTIES OF MERCHANTABILITY OR FITNESS FOR A PARTICULAR PURPOSE. TEKTRONIX' RESPONSIBILITY TO REPAIR OR REPLACE DEFECTIVE PRODUCTS IS THE SOLE AND EXCLUSIVE REMEDY PROVIDED TO THE CUSTOMER FOR BREACH OF THIS WARRANTY. TEKTRONIX AND ITS VENDORS WILL NOT BE LIABLE FOR ANY INDIRECT, SPECIAL, INCIDENTAL, OR CONSEQUENTIAL DAMAGES IRRESPECTIVE OF WHETHER TEKTRONIX OR THE VENDOR HAS ADVANCE NOTICE OF THE POSSIBILITY OF SUCH DAMAGES.**

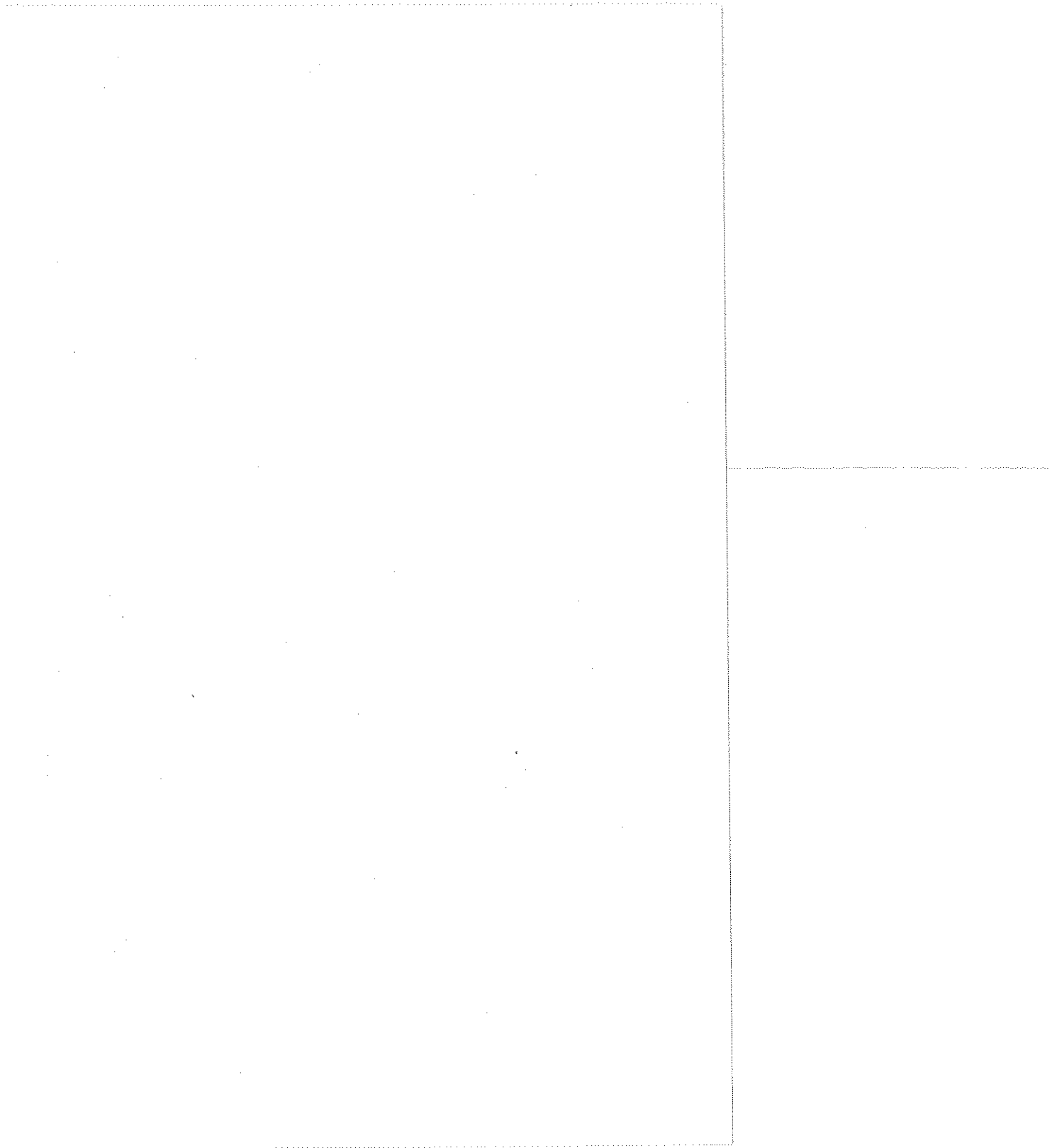

# Table of Contents

|   |           |
|---|-----------|
| <b>General Safety Summary</b> .....                   | <b>v</b>  |
| <b>Preface</b> .....                                  | <b>ix</b> |
| Organization .....                                    | ix        |
| <b>Getting Started</b> .....                          | <b>1</b>  |
| Product Description .....                             | 1         |
| Configuration .....                                   | 2         |
| Fuse Selection .....                                  | 3         |
| Setting the Operating Voltage .....                   | 3         |
| Rotating the Handle .....                             | 3         |
| Probe Compensation .....                              | 4         |
| Functional Check .....                                | 6         |
| <b>Operating Basics</b> .....                         | <b>9</b>  |
| Checking Display Status .....                         | 9         |
| Reading the On-Screen Display .....                   | 9         |
| Displaying CH1 or CH2 .....                           | 10        |
| Displaying CH1 and CH2 .....                          | 10        |
| Displaying the Sum or Difference of CH1 and CH2 ..... | 11        |
| Comparing Frequency and Phase .....                   | 12        |
| Setting Up Single-Sweep Operation .....               | 13        |
| Magnifying Waveform Events .....                      | 14        |
| Measuring Waveforms .....                             | 14        |
| Using the Trigger .....                               | 16        |
| Trigger Modes .....                                   | 16        |
| Triggering Sources .....                              | 16        |
| Trigger Coupling .....                                | 16        |
| Trigger Slope .....                                   | 16        |
| SET TO 50% .....                                      | 16        |
| Trigger Level .....                                   | 16        |
| Using HOLDOFF .....                                   | 16        |

## Table of Contents

---

|  |           |
|--|-----------|
| <b>Reference</b> .....                     | <b>17</b> |
| Front Panel Organization .....             | 17        |
| Display Controls .....                     | 18        |
| Vertical Controls .....                    | 19        |
| Horizontal Controls .....                  | 21        |
| Measurement and Readout Controls .....     | 22        |
| Trigger Controls .....                     | 23        |
| Input Connectors .....                     | 26        |
| Rear Panel Organization .....              | 27        |
| <b>Appendix A: Maintenance</b> .....       | <b>29</b> |
| Cleaning .....                             | 29        |
| Preparation for Shipment .....             | 29        |
| Replacing the Bezel .....                  | 30        |
| <b>Appendix B: Replaceable Parts</b> ..... | <b>33</b> |
| Standard Accessories .....                 | 33        |
| Optional Accessories .....                 | 33        |
| <b>Appendix C: Specifications</b> .....    | <b>35</b> |
| <b>Glossary</b> .....                      | <b>43</b> |
| <b>Index</b> .....                         | <b>47</b> |

## List of Figures

|   |    |
|---|----|
| Figure 1: Fuse Installation and Voltage Configuration ..... | 2  |
| Figure 2: Typical Compensation Waveforms .....              | 5  |
| Figure 3: Probe Compensation Adjustment .....               | 5  |
| Figure 4: Functional Check Display 1 .....                  | 6  |
| Figure 5: Functional Check Display 2 .....                  | 7  |
| Figure 6: Typical BOTH Waveform .....                       | 10 |
| Figure 7: Typical ADD Waveform .....                        | 11 |
| Figure 8: Typical X-Y Display .....                         | 12 |
| Figure 9: Typical $\Delta V$ Readout .....                  | 15 |
| Figure 10: Typical $\Delta T$ Readout .....                 | 15 |
| Figure 11: TAS220 and TAS250 Front Panel Organization ...   | 17 |
| Figure 12: Bezel Replacement (Step 3) .....                 | 30 |
| Figure 13: Bezel Replacement (Step 4) .....                 | 31 |
| Figure 14: Bezel Replacement (Step 6) .....                 | 31 |

## List of Tables

|   |    |
|---|----|
| Table 1: Standard Accessories .....                               | 33 |
| Table 2: Optional Accessories .....                               | 33 |
| Table 3: Accessory Power Cords .....                              | 34 |
| Table 4: Vertical Deflection Characteristics .....                | 36 |
| Table 5: Horizontal Characteristics .....                         | 37 |
| Table 6: Readout Characteristics .....                            | 37 |
| Table 7: Trigger Characteristics .....                            | 38 |
| Table 8: Typical Z-Axis Characteristics .....                     | 38 |
| Table 9: Typical X-Y Mode Operation .....                         | 39 |
| Table 10: Typical Probe Compensation Signal Characteristics ..... | 39 |
| Table 11: Environmental Characteristics .....                     | 40 |
| Table 12: Typical Mechanical Characteristics .....                | 41 |



## General Safety Summary

Review the following safety precautions to avoid injury and prevent damage to this product or any products connected to it.

### Injury Precautions

#### **Use Proper Power Cord**

To avoid fire hazard, use only the power cord specified for this product.

#### **Avoid Electric Overload**

To avoid electric shock or fire hazard, do not apply a voltage to a terminal that is outside the range specified for that terminal.

#### **Ground the Product**

This product is grounded through the grounding conductor of the power cord. To avoid electric shock, the grounding conductor must be connected to earth ground. Before making connections to the input or output terminals of the product, ensure that the product is properly grounded.

#### **Do Not Operate Without Covers**

To avoid electric shock or fire hazard, do not operate this product with covers or panels removed.

#### **Use Proper Fuse**

To avoid fire hazard, use only the fuse type and rating specified for this product.

## General Safety Summary

---

### **Do Not Operate in Wet/Damp Conditions**

To avoid electric shock, do not operate this product in wet or damp conditions.

### **Do Not Operate in Explosive Atmosphere**

To avoid injury or fire hazard, do not operate this product in an explosive atmosphere.

## Product Damage Precautions

### **Use Proper Power Source**

Do not operate this product from a power source that applies more than the voltage specified.

### **Use Proper Voltage Setting**

Before applying power, ensure that the line selector is in the proper position for the power source being used.

### **Do Not Immerse in Liquids**

Clean the probe using only a damp cloth. Refer to cleaning instructions.

## Safety Terms and Symbols

### Terms in This Manual

These terms may appear in this manual:



**WARNING.** Warning statements identify conditions or practices that could result in injury or loss of life.



**CAUTION.** Caution statements identify conditions or practices that could result in damage to this product or other property.

### Terms on the Product

These terms may appear on the product:

**DANGER** indicates an injury hazard immediately accessible as you read the marking.

**WARNING** indicates an injury hazard not immediately accessible as you read the marking.

**CAUTION** indicates a hazard to property including the product.

### Symbols on the Product

The following symbols may appear on the product:



**DANGER**  
High Voltage



Protective Ground  
(Earth) Terminal



**ATTENTION**  
Refer to  
Manual



Double  
Insulated

## Certifications and Compliances

### **CSA Certified Power Cords**

CSA Certification includes the products and power cords appropriate for use in the North America power network. All other power cords supplied are approved for the country of use.



## Preface

This manual describes the operation of both the TAS 220 and TAS 250 analog oscilloscopes. The optional *Service Manual* contains performance verification and adjustment information, as well as an expanded replaceable parts list.

### Organization

This manual is organized into six chapters:

#### **Getting Started**

This chapter provides information for the set up and first time use of the oscilloscope.

#### **Operating Basics**

This chapter describes the basic operation of the oscilloscope.

#### **Reference**

This chapter contains information on the location and function of the oscilloscope controls.

#### **Appendices**

This chapter describes maintenance procedures, specifications, and replaceable parts information.

#### **Glossary**

This chapter defines terms in the manual that may be unfamiliar to the reader.

#### **Index**

This chapter provides an alphabetical listing for information in the manual.

Preface

---

## Getting Started

This chapter describes how to set up your oscilloscope for first time use.

### Product Description

The TAS 220 and TAS 250 oscilloscopes are dual-channel products with frequency bandwidths of DC to 20 MHz and DC to 50 MHz respectively. They also feature a maximum sensitivity 1 mV/division with a maximum sweep speed of 10 ns/division.

Additionally, the oscilloscopes offer several other features:

- **Temperature Compensation:** The oscilloscope uses a temperature compensation circuit to reduce the drift of base lines and DC balance.
- **SET TO 50%:** This trigger feature automatically sets the trigger level to the 50% point of the signal.
- **TV Sync :** The oscilloscope has a sync separator circuit for triggering on composite signals. Vertical and horizontal signals are automatically selected by the SEC/DIV control.
- **Linear Focus:** The focus is automatically maintained regardless of intensity change after it has been adjusted to the optimum intensity.

## Configuration

Before operating the oscilloscope, install the correct fuse, set the correct operating voltage, and rotate the handle to a useful position.



**WARNING.** To avoid personal injury, disconnect the power cord before removing the fuse holder.

The oscilloscope operates off of a wide range of line voltages. Both the line voltage and input protection are selected by the fuse holder. To change the operating voltage or line fuse, gently remove the fuse holder. Refer to Figure 1.

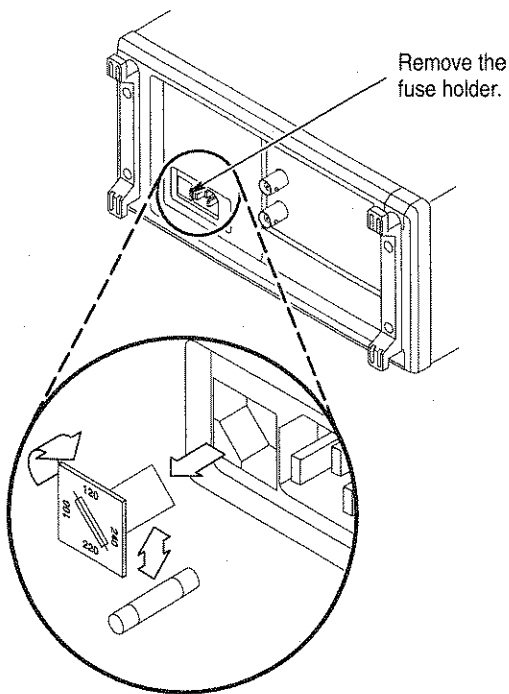

Figure 1: Fuse Installation and Voltage Configuration

### **Fuse Selection**

The value of the input fuse is determined by the operating voltage. Make sure that the correct fuse is installed for the operating voltage:

- 100 V–120 V 0.6 A
- 220 V–240 V 0.3 A

Refer to the *Replaceable Parts* section for ordering information.

### **Setting the Operating Voltage**

To set the operating voltage, remove and rotate the fuse holder so that it points to the operating voltage.

### **Rotating the Handle**

To rotate the handle, pull both sides away from the cabinet and rotate the handle to the desired position. The handle locks into place and can be used to carry the oscilloscope or support it for easy viewing.

## Probe Compensation

To minimize distortion in measured waveforms, check the compensation of your probes before using them. The probe compensation should be checked periodically and whenever the probes are moved to different input channels.

1. Install the probes onto the oscilloscope. (Press the BNC connector onto the channel input and rotate the connector to lock it into place.)
2. Set the probe slide switches to the **10X** position.
3. Set the **VERTICAL MODE** control to the **CH1** position.
4. Set the **PROBE X1/X10** button to the **X10** position.
5. Set the **VERTICAL MODE** control to the **CH2** position.
6. Set the **PROBE X1/X10** button to the **X10** position.
7. Attach the probe tips to the **PROBE COMP** connection on the front of the oscilloscope.
8. Adjust the oscilloscope controls to display both channels:

|                   |        |
|-------------------|--------|
| SEC/DIV           | 0.5 ms |
| VERTICAL MODE     | BOTH   |
| VERTICAL COUPLING | DC     |
| VOLTS/DIV         | 1 V    |
| TRIGGER MODE      | AUTO   |
| CHOP              | IN     |
9. Observe the displayed waveforms and compare them to the waveforms shown in Figure 2. If either probe needs to be adjusted, proceed to step 10. If either probe does not need to be adjusted, proceed to the Functional Check on page 6.

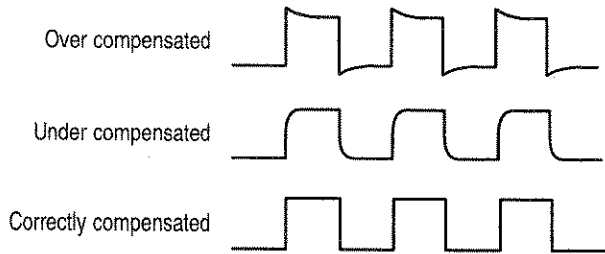

**Figure 2: Typical Compensation Waveforms**

10. Adjust the probe using a small, insulated screwdriver. Slowly rotate the adjustment control until the probe is properly compensated. Refer to Figure 3 for the location of the probe compensation adjust.

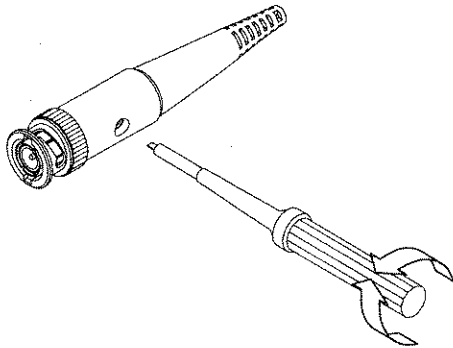

**Figure 3: Probe Compensation Adjustment**

## Functional Check

To check the operation of your oscilloscope for the first time, perform the following instructions:

1. Install the probes onto the **CH1** and **CH2** inputs.
2. Connect the probe tips to the **PROBE COMP** test point on the oscilloscope.
3. Adjust the oscilloscope controls to display both channels:

|                   |        |
|-------------------|--------|
| SEC/DIV           | 0.5 ms |
| VERTICAL MODE     | BOTH   |
| VERTICAL COUPLING | DC     |
| VOLTS/DIV         | 1 V    |
| TRIGGER MODE      | AUTO   |
| CHOP              | IN     |

Figure 4 illustrates a satisfactory display. The waveforms should be approximately 2 V<sub>p-p</sub> at a frequency of 1 kHz. This confirms the vertical and horizontal deflection functions of the oscilloscope.

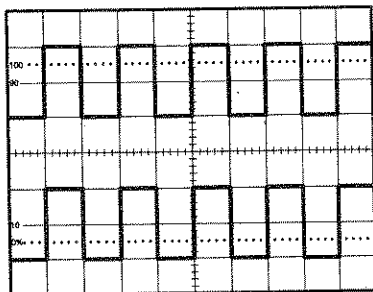
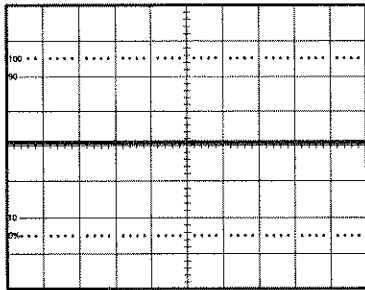

Figure 4: Functional Check Display 1

4. Set both **CH1** and **CH2 COUPLING** to **GND**.
5. Use the **VERTICAL POSITION** controls to align both traces on the center graticule.
6. Set the **CH2 INV** button to the **IN (ON)** position.

7. Set the **VERTICAL MODE** control to the **ADD** position.
8. Set both **CH1** and **CH2 COUPLING** to **DC**.
9. Figure 5 shows a satisfactory display. The display should show a flat trace located on the center graticule: this confirms the channel balance and **ADD** offset functions.



**Figure 5: Functional Check Display 2**

10. Set the **VERTICAL MODE** control to the **CH1** position.
11. Set the **CH2 INV** button to the **OUT (OFF)** position.
12. Set the **CHOP** button to the **OUT (OFF)** position.

## Getting Started

---

## Operating Basics

This chapter describes the basic operation of the oscilloscope.

### Checking Display Status

The oscilloscope CRT displays both control status and waveforms.

#### Reading the On-Screen Display

The status for each channel is displayed on the CRT. To add or remove the readouts from the display, press the PROBE X1/X10 and CURSOR ON/OFF buttons at the same time.

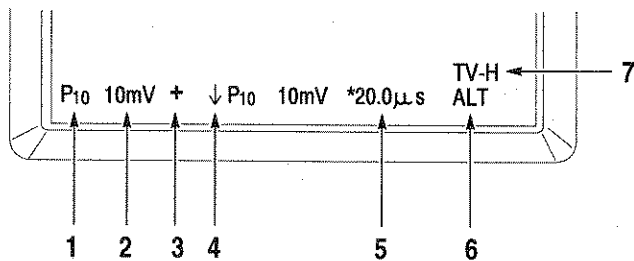

1. Indicates that the voltage readout (2) is scaled for a 10X probe.
2. Indicates the volts per division setting for the channel.  
A > symbol indicates that the channel VARIABLE control is off of the calibrated position.
3. Indicates that the vertical MODE switch is in the ADD position.
4. Indicates that CH2 is inverted.
5. Indicates the time base setting. A \* symbol indicates that the X10MAG button is pressed. A > symbol indicates that the SWP UNCAL button is pressed.
6. Indicates the display method when both signals are displayed.  
Either ALT or CHOP is displayed in the BOTH mode.
7. Indicates that triggering is in the TV-H or TV-V mode.

### Displaying CH1 or CH2

To display the signal from a single channel, place the **VERTICAL MODE** switch in either the **CH1** or **CH2** position.

### Displaying CH1 and CH2

To display both signals at the same time, follow these steps:

1. Set the **VERTICAL MODE** control to the **BOTH** position.  
Figure 6 shows two signals in the **BOTH** mode.
2. Adjust the **VERTICAL POSITION** control to position the two waveforms.
3. Press the **TRIG BOTH** button in the trigger section to stabilize the display of two nonsynchronous waveforms.

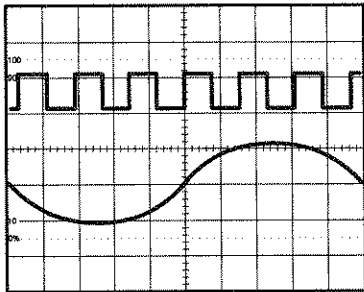

Figure 6: Typical BOTH Waveform

4. Press the **CHOP** button if the waveforms are flickering.

### Displaying the Sum or Difference of CH1 and CH2

To display the algebraic sum or difference of CH1 and CH2, follow these steps:

1. Set the **VERTICAL MODE** control to the **ADD** position.  
Figure 7 shows the sum of the waveforms from Figure 6.

---

**NOTE.** The internal triggering source signal is selected by **SOURCE** switch when in the **ADD** mode.

---

2. Press the **CH2 INV** button if necessary to display the difference waveform.
3. Adjust one of the the **VARIABLE** controls to adjust one channel to the other in the event of gain differences.

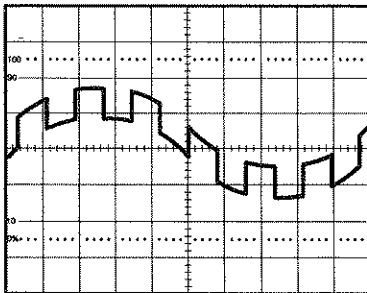

Figure 7: Typical ADD Waveform

### Comparing Frequency and Phase

To compare the frequency and phase between two signals, use the X-Y mode. The X-Y waveform displays differences in amplitude, frequency, and phase. Figure 8 shows a typical waveform made up of two signals that are of the same frequency and amplitude, but approximately 45° out of phase.

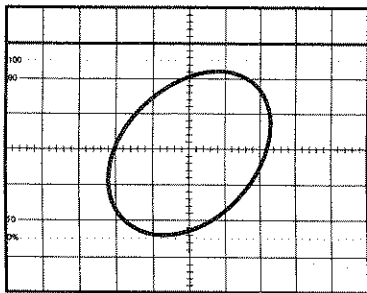

Figure 8: Typical X-Y Display

To use the oscilloscope in the X-Y mode, follow these steps:

1. Connect the horizontal or X-axis signal to the **CH1** input.
2. Connect the vertical or Y-axis signal to the **CH2** input.
3. Set the **X-Y** button to the in position.
4. Set the **VERTICAL MODE** control to **CH2**.
5. Set the **TRIGGER SOURCE** control to **CH1** or **CH2**.

Use the **HORIZONTAL POSITION** control to adjust the X-axis.

---

**NOTE.** When high frequency signals are displayed in the X-Y operation, note the frequency bandwidths and phase differences between X and Y axis. Refer to Table 9 on page 39 in the Specifications section for details.

---

### Setting Up Single-Sweep Operation

One-shot and nonrepetitive signals are difficult to view using repetitive sweep operation. These signals can be viewed by displaying them in the single-sweep mode and photographing them.

---

**NOTE.** *Single-sweep operation does not work in the dual-trace ALT mode. Set the CHOP button to the IN (ON) position and set the trigger controls to the desired trigger source.*

---

**One-shot Signals.** Use this method to view nonrecurring events:

1. Set the **TRIGGER MODE** to **NORM**.
2. Apply the **PROBE COMP** signal to the vertical input and adjust the triggering level to a value corresponding to the predicted amplitude of the measured signal.
3. Set the **TRIGGER MODE** to **SGL SWP** (all three mode buttons are out).
4. Remove the **PROBE COMP** signal from the vertical input and connect the signal to be viewed.
5. Press the **SGL SWP** button. The trigger circuit resets and the **READY** lamp lights.
6. As the event occurs, the sweep is triggered and the one-shot signal displayed on the CRT.

**Nonrepetitive Signals.** Use this method for recurring events that are not periodic.

1. Set the **TRIGGER MODE** to **NORM**.
2. Connect the signal to the channel input and adjust the trigger level.
3. Set the trigger mode to **SGL SWP** (all three mode buttons are out).
4. Press the **SGL SWP** button and the sweep passes only once.

### Magnifying Waveform Events

Use the X10 MAG control to view small portions of a waveform that are too far back from the starting point to view using the SEC/DIV control. To use the X10 MAG control, follow these steps.

1. Adjust the **SEC/DIV** control to the fastest sweep that displays the event.
2. Set the **X10 MAG** button to the **ON (IN)** position.
3. Rotate the **HORIZONTAL POSITION** control to display the event.

---

**NOTE.** *The CRT readout automatically displays the correct time per division when the X10 MAG button is used.*

---

### Measuring Waveforms

Use the cursors for accurate and easy of measurements of waveform characteristics. The cursors can be used to take either time, period, or voltage measurements.

To take a measurement using cursors, perform the following steps:

1. Press the **CURSOR ON/OFF** button to turn on the cursors and measurement readout.
2. Press the  **$\Delta V$   $\Delta T$ – $1/\Delta T$**  button to select the either the  $\Delta V$  or  $\Delta T$ – $1/\Delta T$  measurement function.
3. Press the **TRACKING** button to select the cursor(s) to be moved. The selected cursor is indicated by either a  $\blacklozenge$  or  $\bullet$  symbol. When both symbols are displayed the two cursors can be shifted simultaneously.
4. Rotate the cursor **POSITION** control to position the selected cursor(s).
5. Read the measurement value on the screen. Typical measurement readouts are shown in Figures 9 and 10. The measurement values are automatically controlled by the **VOLTS/DIV** and **SEC/DIV** control settings.

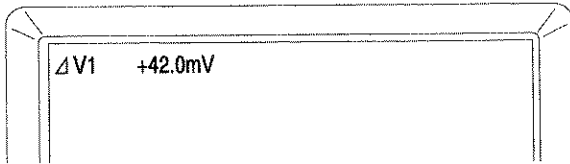

Figure 9: Typical  $\Delta V$  Readout

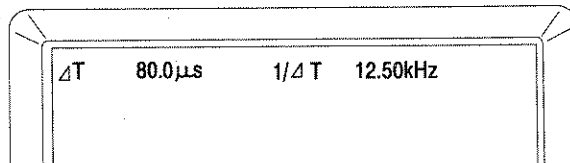

Figure 10: Typical  $\Delta T$  Readout

**NOTE.** When the SEC/DIV or the VOLTS/DIV controls are set to uncalibrated positions, the  $\Delta V$  and  $\Delta T$  measurement values are displayed with divisions.

When the VERTICAL MODE control is in the ADD position and the CH1 and CH2 VOLTS/DIV controls are set to different scales, the  $\Delta V$  measurement values are displayed with divisions.

When the Delta ( $\blacklozenge$ ) cursor is above the REF ( $\bullet$ ) cursor on the screen, the polarity display mode is +.

## Using the Trigger

To display a stable waveform for measurement, you must trigger it. Please take a moment to become familiar with these triggering features:

### Trigger Modes

Select one of the three triggering modes: AUTO, NORM, or SGL SWP.

### Triggering Sources

Set the SOURCE switch to select the triggering source signal.

Press the TRIG BOTH button to stabilize nonsynchronous waveforms when the VERTICAL MODE switch is in the BOTH or ADD positions.

### Trigger Coupling

Set the coupling of the triggering signal to the trigger circuit to AC, HF REJ, TV, or DC.

### Trigger Slope

Press the SLOPE button to select the triggering slope polarity.

### SET TO 50%

Press the SET TO 50% button to automatically set the triggering level to the 50% point on the signal.

### Trigger Level

Use the LEVEL control for setting the start point for the waveform in the NORM mode.

### Using HOLDOFF

Use the HOLDOFF control to trigger on signals with large duty-cycles.

## Reference

This chapter describes the organization and controls of the oscilloscope.

### Front Panel Organization

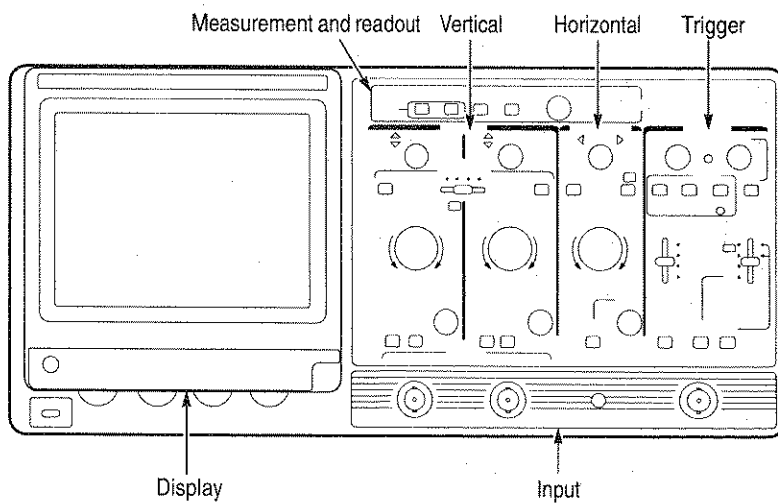

Figure 11: TAS220 and TAS250 Front Panel Organization

The front panel is divided into six sections:

- display controls
- vertical controls
- horizontal controls
- measurement and readout controls
- trigger controls
- input connectors

### Display Controls

The display controls adjust the on-screen appearance of the waveform and provides a probe compensation signal source.

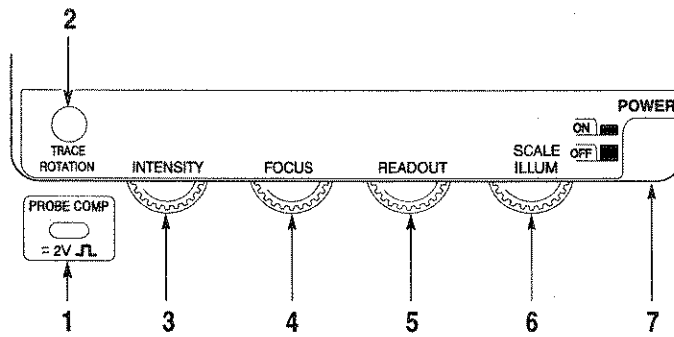

1. The PROBE COMP terminal provides a reference signal for probe adjustment. The signal is 2 Vp-p at 1 kHz.
2. The TRACE ROTATION potentiometer controls the horizontal angle of the trace.
3. The INTENSITY knob controls the brightness of the trace.
4. The FOCUS knob controls the clarity of the display.
5. The READOUT knob controls the brightness of the readout and cursors.
6. The SCALE ILLUM knob controls the graticule illumination brightness.
7. Main instrument power switch.

## Vertical Controls

The vertical controls select the signals that are displayed and control their amplitude characteristics.

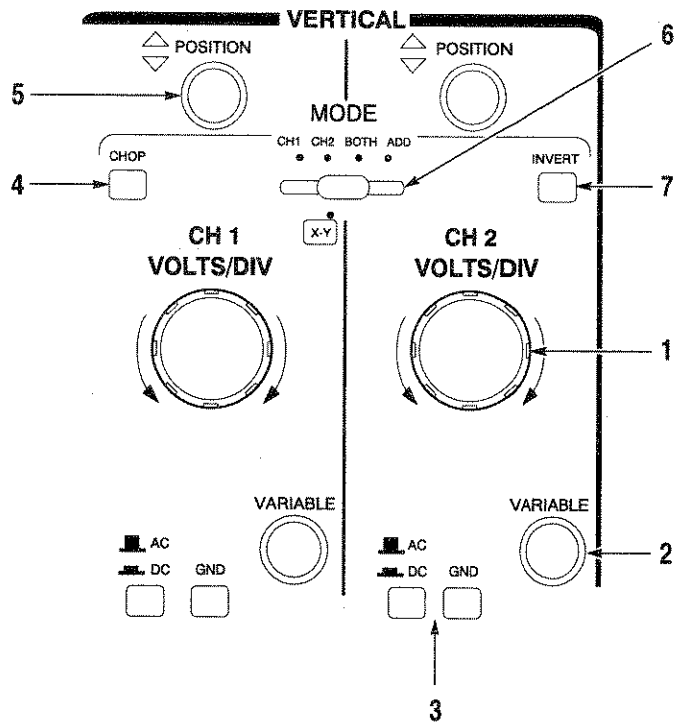

1. The VOLTS/DIV control adjusts the vertical axis sensitivity from 1 mV/DIV to 5 V/DIV with 12 ranges. (The ranges step in a 1-2-5 sequence.)
2. The VARIABLE control fine adjusts the VOLTS/DIV sensitivity. Set the VARIABLE control to the CAL position to set the scale to the calibrated VOLTS/DIV setting.

## Reference

---

3. The two coupling buttons select the coupling mode between input signal and vertical amplifier.

AC: Only the AC signal component is displayed.

DC: Both the AC and DC signal components are displayed.

GND: The input to the amplifier is grounded and disconnected from the signal input. Use this button to determine the ground reference level on the display.

4. The CHOP button selects the chop display method when both signals are being displayed.

Push in the CHOP button to use chopping for dual display on all sweep ranges. When the CHOP button is out, the oscilloscope automatically selects the display function based on the SEC/DIV control.

|       |                            |
|-------|----------------------------|
| CHOP: | 0.5 s/DIV – 5 ms/DIV       |
| ALT:  | 2 ms/DIV – 0.1 $\mu$ s/DIV |

---

**NOTE.** Use the CHOP function to reduce flickering at slow sweep speeds. Use the ALT mode if waveform distortion occurs.

---

5. The POSITION control adjusts the vertical position of the waveform.
6. The MODE control selects the channel or channels to be displayed. Either channel can be displayed individually, both channels can be displayed at the same time (BOTH), or both channels can be added together algebraically (ADD) to observe sum or difference characteristics.
7. The INVERT button inverts the phase of the CH2 signal 180° for use in sum or difference operations.

## Horizontal Controls

The horizontal controls adjust the horizontal scale, position, and magnification of the signal.

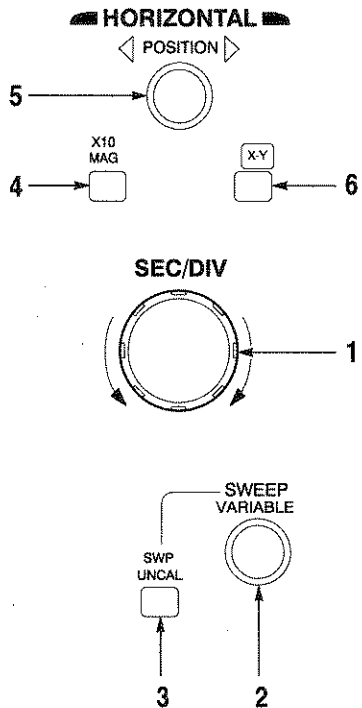

1. The SEC/DIV control selects the sweep period.
2. The SWEEP VARIABLE control fine adjusts the sweep time.
3. The SWP UNCAL button enables operation of the SWEEP VARIABLE control.
4. The X10 MAG button magnifies the sweep rate by a factor of ten.
5. The POSITION control adjusts the horizontal position of the trace.
6. The X-Y button enables X-Y operation.

### Measurement and Readout Controls

The measurement/readout section controls the on-screen readout and the cursor measurements. For more information on cursor operations, refer to page 14.

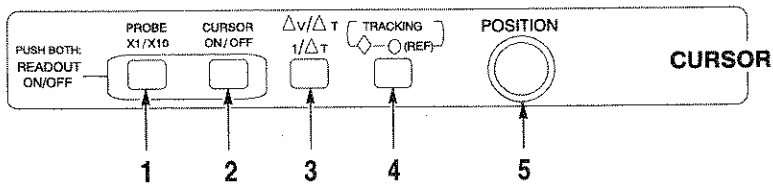

1. The PROBE X1/X10 button automatically scales the readout for either 1X or 10X probe attenuation. This control affects only the channels that are selected by the VERTICAL MODE switch. If both channels are selected, both scale factors toggle between scale factors of one and ten.
2. The CURSOR ON/OFF button turns the cursors and measurement readout on and off.
3. The  $\Delta T$   $1/\Delta T$   $\Delta V$  button selects either horizontal or vertical cursors.
4. The TRACKING button selects the cursor to be moved by the cursor POSITION control. The cursor(s) with the active symbol can be moved.
5. The POSITION knob controls the position of the selected cursor(s).

**NOTE.** To remove the readouts from the display, press the **PROBE X1/X10** and **CURSOR ON/OFF** buttons at the same time.

### Trigger Controls

The trigger controls determine the sweep start timing for both single and dual trace operation.

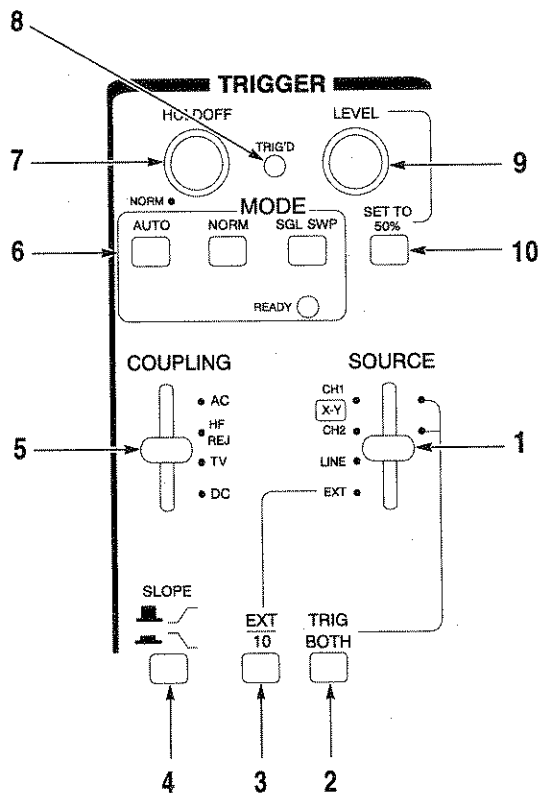

1. The SOURCE switch selects the triggering signal from one of four sources: CH1, CH2, LINE, or EXT.

The CH1 and CH2 trigger sources use the CH1 and CH2 signals as the trigger source.

The LINE trigger source uses the AC power line frequency signal as the triggering signal.

The EXT trigger source uses the external signal connected to the external trigger input. (The external signal must have a time relationship to the measured signal.)

2. The TRIG BOTH button stabilizes nonsynchronous waveforms when the VERTICAL MODE switch is in the BOTH or ADD positions.
3. The EXT/10 button attenuates the external trigger input by a factor of ten.
4. The SLOPE button selects the triggering slope polarity:
  - ↗ Positive slope triggering occurs when the triggering signal crosses the triggering level in positive-going direction.
  - ↘ Negative slope triggering occurs when the triggering signal crosses the triggering level in negative-going direction.
5. The COUPLING switch selects the trigger coupling mode: AC, HF REJ, TV, and DC.

AC: Removes signal components below 10 Hz (–3 dB). AC coupling can cause waveform jitter when the TRIG BOTH button is being used with a slow sweep speed. If this side effect is noticed, change the coupling to the DC.

HF REJ: Removes signal components above 50 kHz (–3 dB).

DC: Couples the trigger signal directly to the trigger circuit.

TV: Separates the video sync signal from the composite waveform and directs it to the triggering circuit. The TV trigger mode is set by the SEC/DIV control. The horizontal or vertical sync signals are selected based on the SEC/DIV setting:

TV V:           0.5 sec – 0.1 msec  
TV H:           50 μsec – 0.1 μsec

6. Three modes of triggering are available: AUTO, NORM, and SGL SWP.

AUTO: Sweeps even if no triggering signal is applied. AUTO is also used when the triggering signal frequency is less than 50 Hz.

NORM: Triggers only when a triggering signal is present. When no triggering signal is applied, the sweep is in a ready state and the trace is blanked.

SGL SWP: Triggers only once until manually reset.

READY: Indicates that the oscilloscope is ready for a single sweep event. (Press the SGL SWP button to reset the sweep circuit before each event.)

7. Use the HOLDOFF control to stabilize the trigger when the signal is too complex to trigger with the LEVEL control alone.
8. The TRIG'D indicator illuminates when the signal waveform is triggered.
9. Adjust the TRIGGER LEVEL control to the threshold point where the trigger circuit begins to display a new sweep. As the triggering signal passes the trigger level, the sweep is triggered and a waveform is displayed on the screen.
10. Press the SET TO 50% button to automatically set the trigger level to the 50% voltage point on the signal regardless of amplitude.

This feature is effective when the signal amplitude on the screen or the input voltage of the external triggering signal is within the following ranges:

TAS220: 50 Hz – 5 MHz: 1.0 DIV (0.15 V) or less  
5 MHz – 20 MHz: 2.0 DIV (0.25 V) or less

TAS250: 50 Hz – 10 MHz: 1.0 DIV (0.15 V) or less  
10 MHz – 40 MHz: 2.0 DIV (0.25 V) or less

### Input Connectors

The input section is where input signals are commonly connected to the oscilloscope.

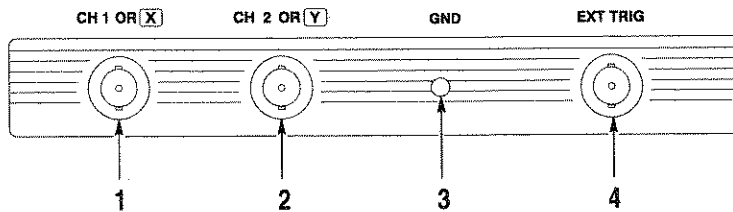

1. CH1 input. When in X-Y operation this is the X-axis input connection.
2. CH2 input. When in X-Y operation this is the Y-axis input connection.
3. Ground terminal to the oscilloscope mainframe.
4. External trigger input. Use this connection for both the external trigger and the external horizontal signal inputs. To use this connection, set SOURCE switch to the EXT position.

The maximum input voltages of the instrument input terminals and probe input terminals are listed in the *Specifications* section. Do not apply voltages higher than these limits.



**CAUTION.** To avoid instrument damage, do not exceed maximum input voltages. Maximum input voltages must have frequencies less than 1 kHz.

## Rear Panel Organization

The rear panel provides input power and additional signal connections.

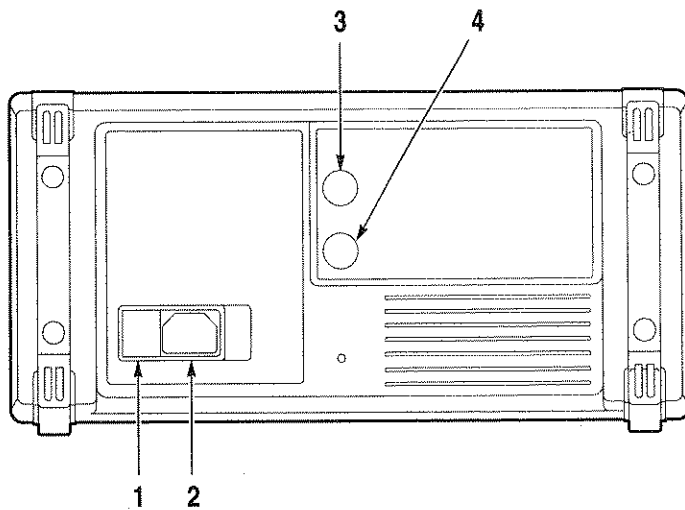

1. Line voltage selector and input fuse holder.
2. Input power connector for the instrument.
3. Z-axis input. This input externally controls the intensity signal.
4. CH1 output. This output may be used to connect to a frequency counter or other instrument.

The maximum input voltages of the instrument input terminals are listed in the *Specifications* section. Do not apply voltages higher than these limits.



**CAUTION.** To avoid instrument damage, do not exceed maximum input voltages. Maximum input voltages must have frequencies less than 1 kHz.

Reference

---

## Appendix A: Maintenance

This section provides the operator with information for the basic maintenance of the mechanical portions of the oscilloscope. The optional *Service Manual* contains performance verification and adjustment information.

### Cleaning

To clean the oscilloscope, use a soft cloth dampened in a solution of mild detergent and water. Do not spray cleaner directly onto the oscilloscope because it may leak into the cabinet and cause damage.

Do not use chemicals containing benzene, benzene, toluene, xylene, acetone, or similar solvents.

Do not use abrasive cleaners on any portion of the oscilloscope.

### Preparation for Shipment

If the original packaging is unfit for use or not available, use the following packaging guidelines:

1. Use a corrugated cardboard shipping carton having inside dimensions at least three inches greater than the oscilloscope dimensions.
2. Put the oscilloscope into a plastic bag or wrap to protect it from dampness and loose packing material.
3. Place the oscilloscope into the box and firmly stabilize it with packing material.
4. Seal the carton with shipping tape.

## Replacing the Bezel

To replace the bezel, perform the following steps:

1. Stand the oscilloscope upright.
2. Rotate the handle out of the way.
3. Press firmly with your thumbs on the top portion of the bezel and slide it upwards. Refer to Figure 12.

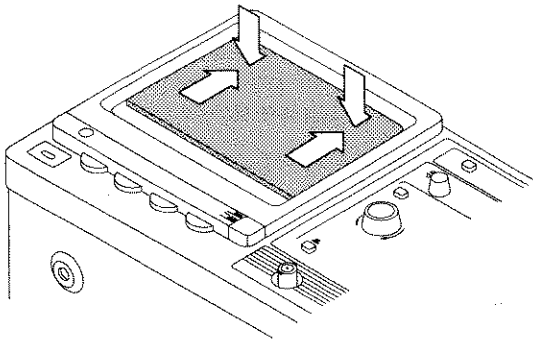
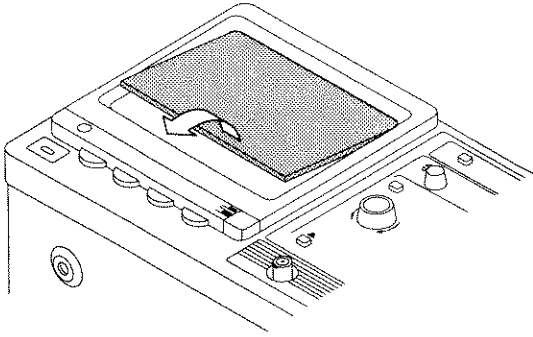

Figure 12: Bezel Replacement (Step 3)

4. Lift the bottom of the bezel and pull it down and out to remove it. Refer to Figure 13.



**Figure 13: Bezel Replacement (Step 4)**

5. Insert the replacement bezel into the frame with the top portion tucked under the top portion of the frame.
6. Gently press the bottom of the bezel until it snaps into the frame.

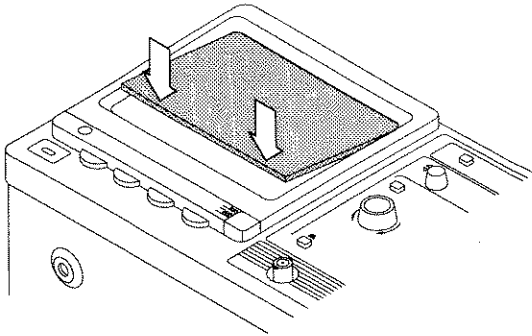

**Figure 14: Bezel Replacement (Step 6)**

Appendix A: Maintenance

## Appendix B: Replaceable Parts

The TAS 220 and TAS 250 replaceable parts may be ordered directly from your Tektronix authorized dealer. The optional *Service Manual* contains an expanded replaceable parts list.

### Standard Accessories

The following items are shipped with the oscilloscope:

**Table 1: Standard Accessories**

| Accessory                                       | Tektronix Part Number |
|---|-----------------------|
| Fuse, 0.6 A Slow Blow<br>100 – 120 V operation  | 159-0384-00           |
| Fuse, 0.3 A, Slow Blow<br>220 – 240 V operation | 159-0387-00           |
| Probes (two)                                    | YT5060                |
| User Manual                                     | 070-9186-XX           |
| Power Cord                                      | Refer to Table 3.     |

### Optional Accessories

The following items are available as optional accessories:

**Table 2: Optional Accessories**

| Accessory      | Tektronix Part Number |
|----------------|-----------------------|
| Service Manual | 070-9215-XX           |
| Bezel          | 378-2078-00           |
| Bottom Feet    | 348-1459-00           |

Appendix B: Replaceable Parts

The following power cords are available:

**Table 3: Accessory Power Cords**

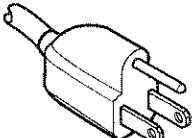
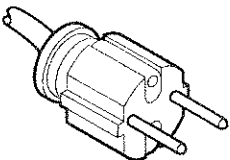
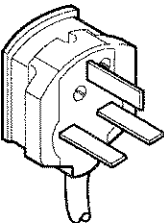
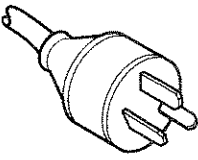
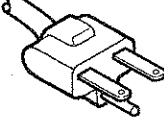
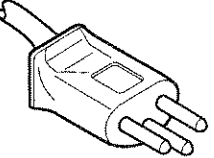
| Plug Configuration  | Normal Usage            | Tektronix Part Number |
|---|-------------------------|-----------------------|
|    | North America<br>115 V  | 161-0104-00           |
|    | Europe<br>230 V         | 161-0104-06           |
|   | United Kingdom<br>230 V | 161-0104-07           |
|  | Australia<br>230 V      | 161-0104-05           |
|  | North America<br>230 V  | 161-0104-08           |
|  | Switzerland<br>230 V    | 161-0167-00           |

## Appendix C: Specifications

The characteristics listed in this section are valid when the oscilloscope has been adjusted at an ambient temperature between +20°C and +30°C, has had a warm-up period of at least 20 minutes, and is operating at an ambient temperature between 0°C and +40°C (unless otherwise noted).

All characteristics are warranted unless noted as typical.

Warranted characteristics are guaranteed to the user. Typical characteristics are not guaranteed, but are provided for the convenience of the user.



---

**CAUTION.** *To avoid instrument damage, do not exceed maximum input voltages. Maximum input voltages must have frequencies less than 1 kHz.*

---

Table 4: Vertical Deflection Characteristics

| Characteristic                              | TAS 220  | TAS 250  |
|---|--|--|
| Frequency Bandwidth<br>(-3dB)               | DC – 20 MHz<br>5 mV – 5 V/DIV<br>(+5°C to 35°C)<br><br>DC – 15 MHz<br>(0 to +5°C, 35°C to<br>40°C)<br><br>DC – 10 MHz<br>1 mV – 2 mV/DIV | DC – 50 MHz<br>5 mV – 5 V/DIV<br>(+10°C to 35°C)<br><br>DC – 40 MHz<br>(0 to +10°C, 35°C to<br>40°C)<br><br>DC – 15 MHz<br>1 mV – 2 mV/DIV |
| Vertical Gain<br>(+15°C to +35°C)           | ±3% 5 mV – 5 V/DIV<br>±5% 1 mV – 2 mV/DIV  |  |
| Variable Gain (typical)                     | To 1/2.5 or less of readout indicated value  |  |
| Common Mode<br>Rejection Ratio<br>(typical) | >50:1 at 50 kHz<br>>10:1 at 10 MHz   |  |
| Input Impedance<br>(typical)                | 1 MΩ, 30 pF  |  |
| Vertical Linearity<br>(typical)             | ±0.1 division or less of amplitude change when<br>waveform of two divisions at graticule center is<br>moved vertically                   |  |
| DC Balance Shift<br>(typical)               | ±0.5 divisions<br>±2.0 divisions   | 5 mV – 5 V/DIV<br>1 mV – 2 mV/DIV  |
| Chopping Repetition<br>Frequency (typical)  | 250 kHz  |  |
| Maximum Input Voltage                       | 400 V (DC + peak AC)   |  |
| Channel Isolation<br>(typical)              | 1000:1 at 50 kHz<br>100:1 at 10 MHz<br>30:1 at 20 MHz  | 1000:1 at 50 kHz<br>100:1 at 10 MHz<br>30:1 at 50 MHz  |
| CH1 Signal Output<br>(typical)              | 100 mV/DIV open circuit<br>50 mV/DIV into 50Ω  |  |
| CH2 INV Balance<br>(typical)                | ≤1 division balanced point variation   |  |

## Appendix C: Specifications

**Table 5: Horizontal Characteristics**

|                               |   |
|-------------------------------|---|
| Standard Sweep Time Accuracy  | $\pm 3\%$ (+15°C to +35°C)<br>$\pm 4\%$ (0 to 15°C, 35°C to 40°C)   |
| Magnified Sweep Time Accuracy | $\pm 5\%$ (1 $\mu\text{s}$ – 0.5 sec/div)<br>$\pm 8\%$ (0.1 $\mu\text{s}$ – 0.5 $\mu\text{s}/\text{div}$ )    |
| Sweep Linearity               | Standard: $\pm 3\%$<br>X10 MAG: $\pm 5\%$<br>( $\pm 8\%$ , 0.1 $\mu\text{s}$ – 0.5 $\mu\text{s}/\text{div}$ ) |

**Table 6: Readout Characteristics**

|                    |  |
|--------------------|--|
| Readout Resolution | 1/25 division                          |
| Readout Accuracy   | $\pm 3\% + 1/25$ division              |
| Readout Modes      | $\Delta V$ , $\Delta T$ , $1/\Delta T$ |

**Table 7: Trigger Characteristics**

| Characteristic            | TAS 220  | TAS 250   |
|---------------------------|--|---|
| Sensitivity               | DC – 5 MHz<br>0.5 divisions (internal)<br>0.1 V (external)     | DC – 10 MHz<br>0.5 divisions (internal)<br>0.1 V (external)     |
|                           | 5 MHz – 20 MHz<br>1.5 divisions (internal)<br>0.2 V (external) | 10 MHz – 50 MHz<br>1.5 divisions (internal)<br>0.2 V (external) |
|                           | Video<br>2.0 divisions (internal)<br>0.2 V (external)          | Video<br>2.0 divisions (internal)<br>0.2 V (external)           |
| Input Impedance (typical) | 1 M $\Omega$ , 30 pF   |   |
| Maximum Input Signal      | 100 V (DC + peak AC)   |   |

**Table 8: Typical Z-Axis Characteristics**

|                       |  |
|-----------------------|--|
| Maximum Input Voltage | 50 V (DC + peak AC)                                  |
| Sensitivity           | 3 Vp-p (Trace becomes brighter with negative input.) |
| Frequency Bandwidth   | DC – 5 MHz   |
| Input Resistance      | 5 k $\Omega$   |

## Appendix C: Specifications

**Table 9: Typical X-Y Mode Operation**

| Characteristic       | TAS 220   | TAS 250                        |
|----------------------|---|--------------------------------|
| Sensitivity          | Same as CH1 vertical axis.                        |                                |
| Sensitivity Accuracy | $\pm 4\%$ 5 mV–5 V/DIV<br>$\pm 6\%$ 1 mV–2 mV/DIV |                                |
| Frequency Bandwidth  | DC – 1 MHz  | DC – 2 MHz                     |
| X–Y Phase Difference | $\leq 3^\circ$ at DC – 50 kHz                     | $\leq 3^\circ$ at DC – 100 kHz |
| EXT HOR Sensitivity  | 0.1 V/DIV   |                                |

**Table 10: Typical Probe Compensation Signal Characteristics**

|                   |                             |
|-------------------|-----------------------------|
| Waveform          | Positive-going square wave. |
| Frequency         | 1 kHz                       |
| Duty Ratio        | 50:50                       |
| Output Level      | 2 Vp-p                      |
| Output Resistance | 2 k $\Omega$                |

Appendix C: Specifications

**Table 11: Environmental Characteristics**

|                   |   |
|-------------------|---|
| Temperature       |   |
| Operating         | 0°C to +40°C  |
| Nonoperating      | -40°C to +70°C  |
|                   | Tested to MIL-T-28800D, paragraphs 4.5.5.1.3 and 4.5.5.1.4, except in 4.5.5.1.3 steps 4 and 5 (0°C operating test) are performed ahead of step 2 (-40°C nonoperating test). Equipment shall remain off upon return to room ambient during step 6. Excessive condensation shall be removed before operating during step 7. |
| Altitude          |   |
| Operating         | To 4,570 meters (15,000 feet). Maximum operating temperature decreased 1°C per 300 m (1,000 feet) above 1,500 m (5,000 feet).   |
| Nonoperating      | To 15,250 meters (50,000 feet).   |
| Relative Humidity |   |
| Operating         | +30°C to +40°C, 90% RH +0%, -5%   |
| Nonoperating      | +30°C to +60°C, 90% RH +0%, -5%   |
|                   | Five cycles (120 hours) referenced to MIL-T-28800D paragraph 4.5.1.2.2 for type III, class 5 instruments. Operating and nonoperating at 90%, +0%, -5% relative humidity (RH).   |

## Appendix C: Specifications

**Table 11: Environmental Characteristics (Cont.)**

|                                    |   |
|------------------------------------|---|
| Vibration (Operating)              | 15 minutes along each of three major axes at a total displacement of 0.015 inch p-p (2.4 g at 55 Hz) with frequency varied from 10 Hz to 55 Hz to 10 Hz in one minute sweeps. Hold for 10 minutes at 55 Hz in each of three major axes. All major resonances must be above 55 Hz. |
| Shock (Operating and nonoperating) | 30 g, half-sine, 11 ms duration, three shocks per axis each direction, for a total of 18 shocks.  |
| Safety Compliance                  | UL1244, CAN/CSA C22.2 No. 231   |

**Table 12: Typical Mechanical Characteristics**

|                     |  |
|---------------------|--|
| Dimensions          | 32.7 cm x 16.2 cm x 46.3 cm<br>(12.9 in x 6.38 in x 18.2 in)               |
| Weight              | 7.0 kg<br>(15.4 lbs)   |
| Operating Voltages  | 100 V, 120 V, 220 V, 240 V<br>10% variation from selector range permitted. |
| Operating Frequency | 50 Hz or 60 Hz   |
| Power Consumption   | 70 VA maximum  |

## Appendix C: Specifications

---

## Glossary

### **AC coupling**

A type of signal transmission that blocks the DC component of a signal but uses the dynamic (AC) component. Useful for observing an AC signal that is normally riding on a DC signal.

### **Accuracy**

The closeness of the indicated value to the true value.

### **Amplitude**

The high waveform value less the low waveform value.

### **Attenuation**

The degree the amplitude of a signal is reduced when it passes through an attenuating device such as a probe or attenuator. That is, the ratio of the input measure to the output measure. For example, a 10X probe will attenuate, or reduce, the input voltage of a signal by a factor of 10.

### **Automatic trigger mode**

A trigger mode that causes the oscilloscope to automatically display a sweep if triggerable events are not detected within a specified time period.

### **Bandwidth**

The highest frequency signal the oscilloscope can accurately display with no more than  $-3$  dB ( $\times .707$ ) attenuation of the original (reference) signal.

### **Channel**

An input used for coupling signals to oscilloscope.

### **Coupling**

The association of two or more circuits or systems in such a way that power or information can be transferred from one to the other. You can couple the input signal to the trigger and vertical systems several different ways.

**Cursors**

Paired markers that you can use to make measurements between two waveform locations. The oscilloscope displays the values (expressed in volts or time) of the position of the active cursor and the distance between the two cursors.

**DC coupling**

A mode that passes both AC and DC signal components to the circuit. Available for both the trigger system and the vertical system.

**Edge Trigger**

Triggering occurs when the oscilloscope detects the source passing through a specified voltage level in a specified direction (the trigger slope).

**Fall time**

A measurement of the time it takes for trailing edge of a pulse to fall from a high-ref value (typically 90%) to a low-ref value (typically 10%) of its amplitude.

**Frequency**

A timing measurement that is the reciprocal of the period. Measured in Hertz (Hz) where 1 Hz = 1 cycle per second.

**Graticule**

A grid on the display screen that creates the horizontal and vertical axes. You can use it to visually measure waveform parameters.

**Ground (GND) coupling**

Coupling option that disconnects the input signal from the vertical system.

**Holdoff, trigger**

A specified amount of time after a trigger signal that elapses before the trigger circuit will accept another trigger signal to help ensure a stable display.

**Horizontal bar cursors**

The two horizontal bars that you position to measure the voltage parameters of a waveform.

**Intensity**

Display brightness.

**Maximum amplitude**

Amplitude (voltage) measurement of the maximum amplitude. Typically the most positive peak voltage.

**Minimum amplitude**

Amplitude (voltage) measurement of the minimum amplitude. Typically the most negative peak voltage.

**Normal trigger mode**

A mode in which the oscilloscope does not display a waveform unless a valid trigger event occurs.

**Oscilloscope**

An instrument for making a graph of two factors. These are typically voltage versus time.

**Peak-to-Peak**

Amplitude (voltage) measurement of the absolute difference between the maximum and minimum amplitude.

**Period**

A timing measurement of the time covered by one complete signal cycle. It is the reciprocal of frequency and is measured in seconds.

**Phase**

A timing measurement between two waveforms of the amount one leads or lags the other in time. Phase is expressed in degrees, where 360° comprise one complete cycle of one of the waveforms. Waveforms measured should be of the same frequency or one waveform should be a harmonic of the other.

**Probe**

An oscilloscope input device.

**Probe compensation**

Adjustment that improves low-frequency response of a probe.

**Rise time**

The time it takes for a leading edge of a pulse to rise from the minimum value (typically 10%) to the maximum value (typically 90%) of its amplitude.

**Sweep speed**

See time base.

**Time base (SEC/DIV)**

The control that lets you define the timing of the sweep, expressed as seconds per division.

**Trigger**

An event that marks time zero in the waveform record. It results in acquisition and display of the waveform.

**Trigger level**

The vertical level the trigger signal must cross to generate a trigger.

**Vertical bar cursors**

The two vertical bars you position to measure the time parameter of a waveform.

**Waveform**

The shape or form (visible representation) of a signal.

**XY format**

A display format that compares the voltage level of two waveforms. It is useful for studying phase relationships between two waveforms.

**YT format**

The conventional oscilloscope display format. It shows the voltage of a waveform (on the vertical axis) as it varies over time (on the horizontal axis).

# Index

## C

### CHI Output

- location, 27
- specifications, 36

### Controls

- cursors, 14, 22
  - display, 18
  - horizontal, 21
  - inputs, 26
  - readout, 22
  - trigger, 23
  - vertical, 19
  - X10 MAG, 14
- Cursors, 14, 22

## D

### Definition

- ac coupling, 43
- accuracy, 43
- amplitude, 43
- attenuation, 43
- auto trigger, 43
- bandwidth, 43
- channel, 43
- coupling, 43
- cursors, 44
- dc coupling, 44
- edge trigger, 44
- fall time, 44
- frequency, 44
- gnd coupling, 44
- graticule, 44

- holdoff trigger, 44
- horizontal cursors, 45
- intensity, 45
- maximum amplitude, 45
- minimum amplitude, 45
- normal trigger, 45
- oscilloscope, 45
- peak-to-peak, 45
- period, 45
- phase, 45
- probe, 45
- probe compensation, 46
- rise time, 46
- sweep speed, 46
- time base, 46
- trigger, 46
- trigger level, 46
- vertical cursors, 46
- waveform, 46
- xy format, 46
- yt format, 46

## F

### Front Panel, 17

#### Fuse

- location, 2, 27
- removal, 2
- selection, 3

## H

- Handle, rotation, 3

## Index

---

### M

#### Maintenance

- bezel removal, 30
- cleaning, 29
- functional check, 6
- packing, 29

#### Measurements

- cursors, 14
- frequency, 12, 14, 22
- period, 14, 22
- phase, 12
- voltage, 14, 22

### O

#### Operating Voltage

- adjustment location, 2, 27
- selection, 3

### P

#### Power Input, 27

#### Probe Compensation, 4

### R

#### Readout, 9, 22

#### Rear Panel, 27

### S

#### Specifications

- CH1 output, 36
- environmental, 40
- horizontal, 37
- introduction, 35
- mechanical, 41
- probe comp signal, 39
- readout, 37
- trigger, 38
- vertical, 36
- x-y, 39
- z axis, 38

### T

#### Trigger

- coupling, 16
- holdoff, 16
- level, 16
- modes, 16
- operation, 16
- SET TO 50%, 16
- single sweep, 13
- slope, 16
- sources, 16

### Z

#### Z-Axis Input

- location, 27
- specifications, 38



