

# Tekniques

The 4050 Series Applications Library Newsletter

June 15, 1980

Vol. 4 No. 4

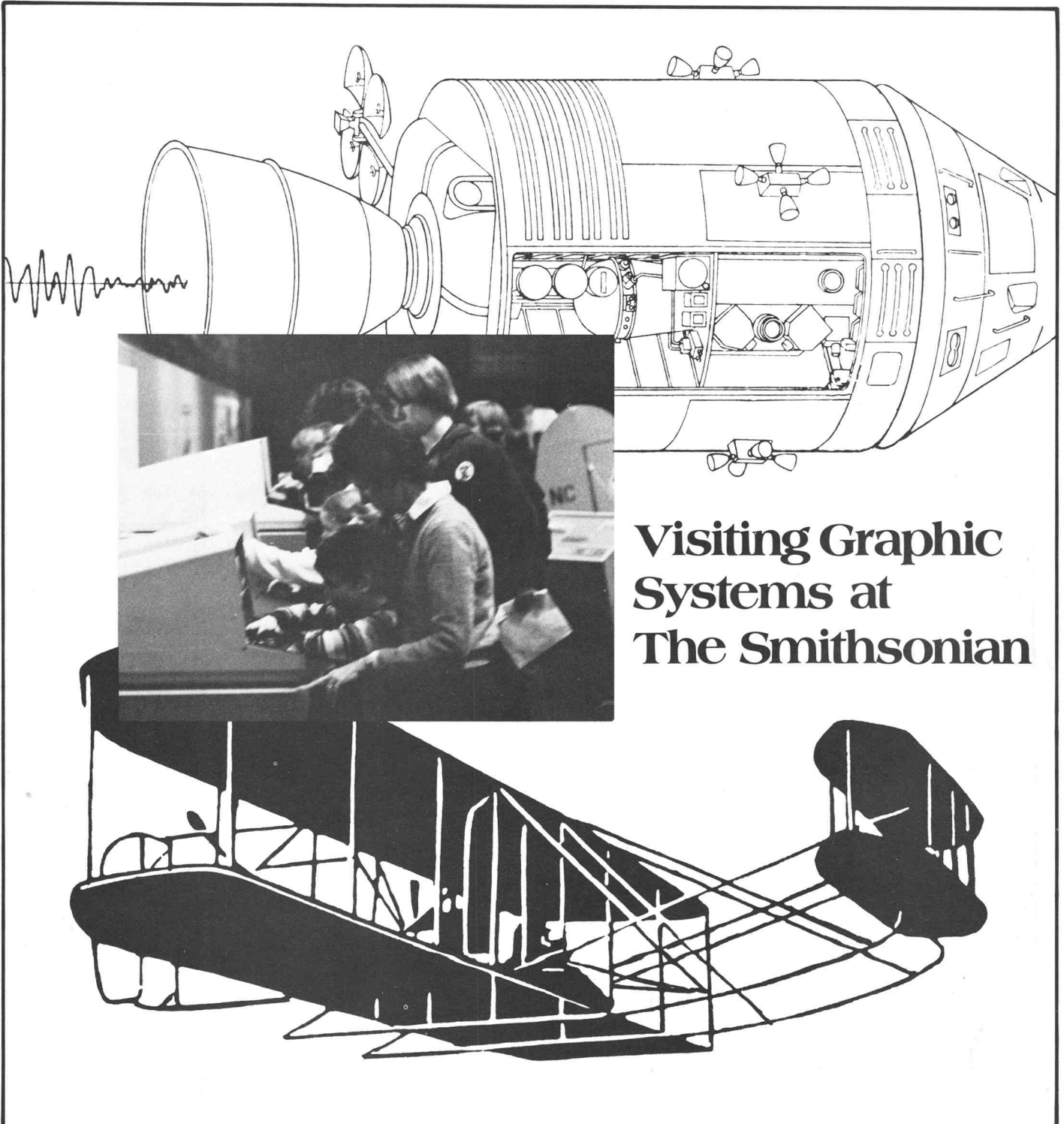

**Visiting Graphic  
Systems at  
The Smithsonian**

# Tekniques

## In This Issue

Visiting Graphic Systems at the Smithsonian.....	2
More at the Smithsonian: Behind the Scenes.....	4
Interfacing Contest Entrants Contribute Unique and Ingenious Programs to 4050 Applications Library.....	10
Transparency Kits Available for Presentation Aids Slides.....	11
4051 Aids in Study of Radioactive Elements.....	12
System Makes Signs for Rose Show.....	15
Editor's Note.....	16
Input/Output.....	17
PLOT 50 Easy Graphing:	
Command Files.....	19
Programming Tips.....	21
BASIC Bits.....	23
New Abstracts.....	24
Library Addresses.....	31

TEKniques, the 4050 Series Applications Library Newsletter, is published by the Information Display Division of Tektronix, Inc., Group 451, P.O. Box 500, Beaverton, Oregon 97077. It is distributed to TEKTRONIX 4050 Series users and members of the 4050 Series Applications Library.

Publishing Manager	Ben Buisman
Managing Editor	Patricia Kelley
Editor	Terence Davis
Technical Editor	Dan Taylor
Graphic Design	John Ellis
Circulation	Rory Gugliotta

Copyright © 1980, Tektronix, Inc.  
All rights reserved.

To submit articles to TEKniques or for information on reprinting articles, write to the above address. Changes of address should be sent to the 4050 Series Library serving your area (see Library addresses).

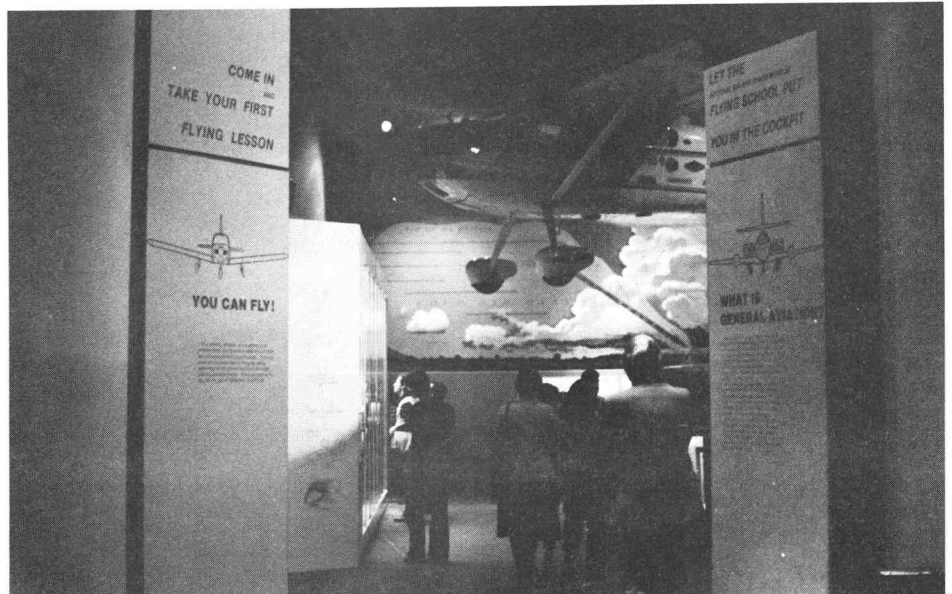

*This inviting entrance offers an experience that's down-to-Earth . . . almost!*



*Here is your ground school in Washington, D.C. The "instructors" are four 4051s programmed to test and teach you.*

### B).....CORRECT

THE AILERONS ON EACH WING SIMULTANEOUSLY MOVE IN OPPOSITE DIRECTIONS IN RESPONSE TO PILOT MOVEMENT OF THE COCKPIT CONTROL (STICK OR WHEEL).

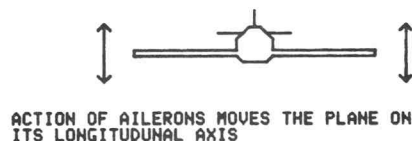

  
TRAILING POSITION

  
LOWERING AILERONS INCREASES LIFT AND RAISES WING

  
RAISING AILERON DECREASES LIFT AND LOWERS WING

STAND BY FOR QUESTION #3

# Visiting Graphic Systems at The Smithsonian

by **Dave Barnard**  
**Tektronix, Inc.**  
**Wilsonville, OR**

If your plans for the summer include a visit to the nation's capitol city, you'll find that the Smithsonian Institution is one of your sightseeing alternatives. Don't resist the urge to visit this historical and scientific archive. And while you're there, drop by the Institution's National Air and Space Museum; 4050 Series Graphic System users will find a familiar sight there.

The exhibits at the Air and Space Museum span the generations from man's first flight up to present-day space exploration. But in the Southwest corner of the museum is one part that will make 4050 System users feel right at home. This room is devoted to the relatively down-to-earth subject of general aviation; the invitation at the entrance, "Let the flying school put you in the cockpit," is reason enough to enter. And once you do, you'll find the exhibit similar to a real flight school in many ways—the flight trainer might be the first thing that catches your eye. And like all flight courses, this one has a ground school too. But this ground school is special.

The faculty of this ground school consists of four 4051 Graphic Systems, and they're ready to give each visitor individual instruction. You may have to wait, as these instructors get a lot of attention. But while you're waiting, check out the two 4051s in the corner. They're programmed to tell you about general aviation airfields near your home.

To find out about airfields, just enter your zip code from the keyboard of one of the systems. (One of the systems "knows" the lower half of the zip codes; the other knows the upper half.) I tested one with an obscure 97062; it replied with a long list of airports near home that are used by small aircraft. Some I'd not thought or known about before, though all were within commuting distance by car. The 4051 was equally unperplexed by 97077, its "home town."

When one of the ground school instructors is available, take a course ranging from pilot

licensing requirements to instrument flight. When you're ready, just press the appropriate function key (they're all labeled). The "instructor" will ask you a question, such as how to bank a plane for a turn. Since it's a multiple choice quiz, you can use trial and error, or you can use the thought-provoking clues provided for you. By the design of the quiz, you'll learn something either way.

When you give the correct answer, you don't just get words; your instructor is equally at ease with words or pictures on the same screen display. The text explains and reinforces what you just learned; a displayed sketch of the aircraft points out the important control surfaces. For the bank turn question, for instance, the display clearly shows that the ailerons are on the wings of the plane, while the text explains their importance in a turn operation. The 4051 will continue to quiz you in this manner until you've been there for a while; you'll then receive a polite reminder to let someone else have a turn.

When you first see the equipment, you may have some difficulty finding the TEKTRONIX label on the front, as some "face-lifting" has been done to protect the

equipment from the heavy use it receives there. A plastic cover replaces the bezel around the screen, and covers all but just a few keys on the keyboard. The remaining numeric keys, function keys, and the return key are sufficient for responding to the instructive questions in the quiz. Covering the unneeded keys, coupled with the clever programming of the Smithsonian staff, tunes the class into the subject of general aviation, rather than diverting them into programming. The white function keys in the upper left part of the keyboard may even seem to be specially contoured, worn a little as a result of the masses of eager learners using them seven days a week. While the systems may look a little weary from their constant use, a human instructor would be overwhelmed in no time by the continuous flow of people, sometimes three or four deep at each machine.

When you've completed your lesson, you'll have learned something about aviation. You'll have had another interesting experience, seeing the familiar 4051 Graphic Systems being used in a completely different way than you're likely used to. And whenever you think you're ready, you can test your new skills on one of the flight simulators. 



*This youngster appears to be helping mom brush up on her flying skills.*

*The Smithsonian staff makes learning fun – on a 4051 and in their many, many other exhibits.*

# More at The Smithsonian: Behind the Scenes.

by **Terry Davis**  
TEKniques staff

with **Patricia Kelley**  
TEKniques staff

## The National Air and Space Museum

There are a number of 4051 Graphic Systems at the National Air and Space Museum, many of them serving as interactive stations for the museum exhibits. Any many visitors are rightly impressed by the displays and their viewer quizzes. In fact, such a surface glance prompted us to look behind the scenes at the museum, and meet the people who make the displays happen. As we meet them, we'll also look more closely at what they're doing, and how.

## Setting Up An Exhibit

In the "classic" museum, displays are primarily artifacts, discovered or preserved, set up with appropriate lighting and a timely backdrop. But with many of the exhibits at the National Air and Space Museum, this isn't the case. Some exhibits are of space hardware or planetary relics, but often the displays relate on-going research or the discovery of concepts or relationships. To provide exhibits of such a nature, the audio-visual department is called upon to provide action or animated film, video tapes, or interactive displays.

Central control of the exhibits resides with Hernan Otano, Chief of Audio Visuals. His department puts exhibits together, obtaining equipment and configuring systems to fit the particular curator's design. The Audio-Visual Department, like the rest of the museum, operates under a philosophy of

self-sufficiency. That means they create their own displays, select the necessary equipment to assemble the exhibit, and maintain and repair the equipment as necessary. If there are programs to be written, they do that as well.

Otano's equipment interest ranges from the capabilities of the system down to the electro-mechanical make-up of the gear. This is important because he and his staff service all displays and the equipment that

they contain. With responsibilities from computer programming to building lighting, ease of maintenance is an important consideration.

Of the displays, Otano notes, "Our maxim is to teach. Not just provide a flashy display and a surface look, but to teach the many visitors something through their visit." He says that graphics and interactivity play a very important part in fulfilling that directive.



*Hernan Otano (center) is Chief of Audio-Visual Systems at the National Air and Space Museum. With him are Dick Wakefield (left) and John Hartman. They are shown in the control center which contains a PDP 11/40. The 11/40 monitors each audio-visual installation plus much of the track lighting. This continuous monitoring takes 34,000 operations, performed at five a second. The 11/40 also starts the exhibits in the morning and shuts them down at night. Otano says in the six years of operation, they have only had 1/2 hour of down time.*

As Mr. Otano's staff assembles an exhibit, they consider factors beyond the display of information, as the concern for maintainability might indicate. The traffic, for instance. The National Air and Space Museum operates 7 days a week, for an average of 10 hours a day (11 hours in the summer). This translates to over a million visitors in an average month. If any of the equipment in the exhibit fails under this load, the failure is usually corrected on the spot. Hernan Otano points out, "everyone on staff knows how to repair all of the equipment in this museum."

### An Example: The General Aviation Exhibit

One typical example of an interactive exhibit is the General Aviation exhibit (described in Dave Barnard's article elsewhere in this issue). In this exhibit, 4051 Graphic Systems were chosen because the exhibit required high-resolution graphic display capabilities to represent the concepts in a way that the audience would appreciate. The format allows visitors to interact with the exhibits, which is the key to success; Hernan Otano looks at the 4051's as "instructors" in a ground training school. And, of course, the program that drives the exhibit displays was written by John Hartman and other staff members on their 4051 Graphic Systems.



*A behind-the-scenes 4051 System located in the control center, is used by Hartman to develop programs for the exhibits, preview exhibit display text and other tasks.*

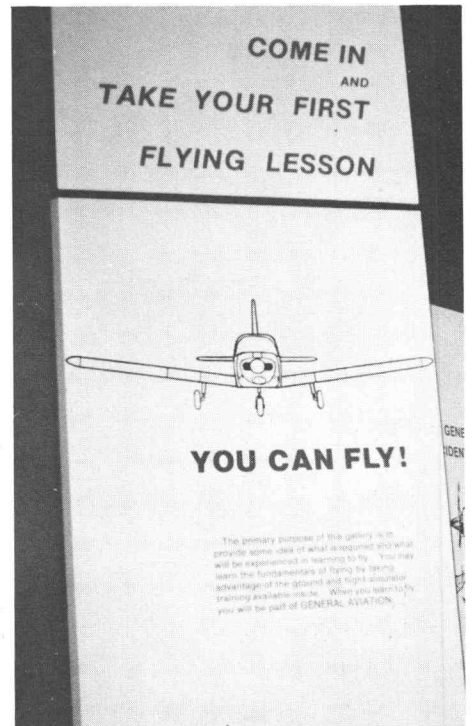

*In the General Aviation exhibit visitors may take a ground school lesson from a 4051 and then move on to a hands-on session in the Link Trainer. It's up to Otano and his staff to choose, install and maintain such equipment.*

The following displays illustrate some of the ground training visitors receive from the 4051s.

**QUIZ #1 QUESTION #1**  
 THE DRAWING SHOWS THE FOUR FORCES WHICH ACT UPON AN AIRPLANE WHICH IS IN STRAIGHT-AND-LEVEL FLIGHT AT A CONSTANT SPEED. THE FORCE AT [1] IS CALLED:

A) LIFT  
 B) THRUST  
 C) WEIGHT  
 D) DRAG

ANSWER)..... CORRECT .....

AN AIRPLANE MUST HAVE THRUST [1] TO PROPEL IT THROUGH THE AIR RAPIDLY ENOUGH TO MAINTAIN LIFT.

STAND BY FOR QUESTION #2

[2] WEIGHT  
 [3] DRAG  
 [4] LIFT

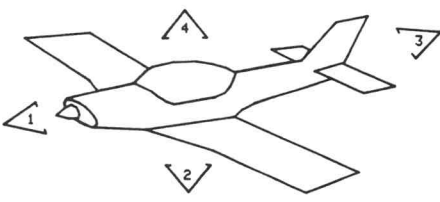

2) THE ANGLE DEFINED AS "THE ANGLE BETWEEN THE RELATIVE WIND AND THE WING CHORD" IS:

A..ANGLE OF ATTACK  
 B..ANGLE OF INCIDENCE  
 C..ANGLE OF SWEEPBACK  
 D..DIEDRAL



ANSWER B..INCORRECT..ANGLE OF INCIDENCE IS THE ANGLE FORMED BY THE LONGITUDINAL AXIS OF THE AIRPLANE AND THE CHORD OF THE WING. IT IS NORMALLY FIXED IN ANY GIVEN AIRPLANE. STAND BY TO TRY AGAIN.

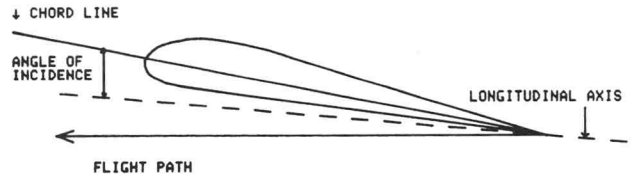

**QUIZ #1 QUESTION #3**  
 THE PITOT-STATIC SYSTEM IS A SOURCE OF AIR PRESSURE FOR OPERATION OF THE:

A)...ALTIMETER  
 B)...VERTICAL SPEED INDICATOR  
 C)...AIRSPEED INDICATOR  
 D)...ALL OF THE ABOVE

ANSWER?  
 D)...CORRECT...THE PITOT-STATIC SYSTEM PROVIDES IMPACT AND STATIC AIR PRESSURE TO THE AIRSPEED INDICATOR AND STATIC PRESSURE TO THE ALTIMETER AND VERTICAL SPEED INDICATOR.

SCHMATIC DIAGRAM OF PITOT HEAD

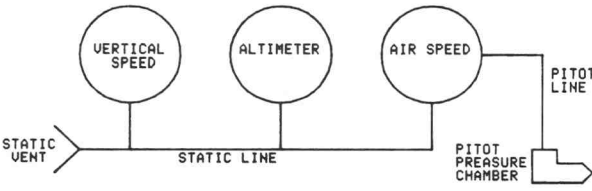

**QUIZ #2 QUESTION #3**  
 THE TYPE OF CLOUD CONSIDERED MOST DANGEROUS TO FLY THROUGH IS THE:

A..CIRROCUMULUS  
 B..ALTOCUMULUS  
 C..STRATOCUMULUS  
 D..CUMULONIMBUS

NAME AND ABBREV.	COMPOSITION	IDENTIFICATION AND WEATHER CHANGES THAT MAY OCCUR
CIRRO CUMULUS Cc	ICE CRYSTALS	HACKEREL SKY STORM APPROACHING.
ALTO CUMULUS Ac	ICE AND WATER	COLD FRONT COLD FRONT MAY BE NEARI OR COULD BE A THUNDERSTORM.
STRATO CUMULUS Sc	WATER	HEAVY ROLLS USUALLY NO ICING PRESENT.
CUMULO NIMBUS Cb	ICE AT TOP WATER	THUNDERHEAD (ANUL-LIKE TOP.)

D...CORRECT...A CUMULONIMBUS CLOUD IS A HEAVY MASS OF CLOUD WITH GREAT VERTICAL DEVELOPMENT. IT GENERALLY PRODUCES SHOWERS OF RAIN OR SNOW, SOMETIMES OF HAIL, AND OFTEN THUNDERSTORMS AS WELL. THE SENSIBLE PILOT NEVER ATTEMPTS TO FLY THROUGH OR UNDER SUCH A CLOUD.

APPROX. ALTITUDE 1,500' TO 50,000'

NAME AND ABBREV.	COMPOSITION	IDENTIFICATION AND WEATHER CHANGES THAT MAY OCCUR
CUMULUS Cu	WATER	FAIR WEATHER GENERALLY IMPROVING CONDITIONS.
CUMULO NIMBUS Cb	ICE AT TOP WATER	THUNDERHEAD (ANUL-LIKE TOP.) RAIN, HAIL, UIOLENT DRAFTS AND STRONG, GUSTY WINDS.

**QUIZ #2 QUESTION #1**  
 IF AN AIRCRAFT FLIES AT AN AIRSPEED OF 120 MPH INTO A DIRECT WIND OF 20 MPH:

A..GROUNDSPEED WILL BE 140 MPH  
 B..GROUNDSPEED WILL BE 100 MPH  
 C..AIRSPEED WILL BE 100 MPH  
 D..GROUNDSPEED WILL BE 120 MPH

STAND BY FOR QUESTION #2

ANSWER  
 B..CORRECT..MOTION OF THE AIR AFFECTS THE SPEED WITH WHICH AIRPLANES MOVE OVER THE EARTH'S SURFACE. AIRSPEED, THE RATE AT WHICH A PLANE MOVES THROUGH THE AIR, IS NOT AFFECTED BY AIR MOTION.

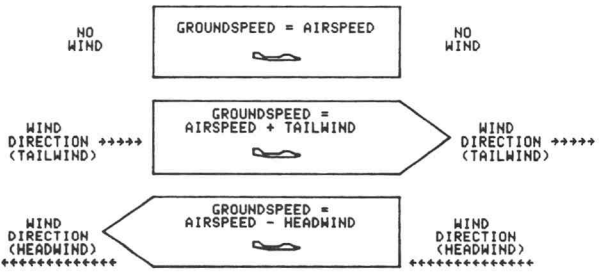

**QUIZ #6 QUESTION #2**  
 AIRPLANES OF 12,500 LBS. OR LESS MANUFACTURED AFTER 1945 AND CERTIFIED BY FAA ARE REQUIRED TO HAVE AIRSPEED INDICATORS THAT CONFORM TO A STANDARD COLOR-CODED MARKING SYSTEM, AS ILLUSTRATED, BELOW. IF A PILOT NOTES THAT HIS AIRSPEED NEEDLE IS IN THE GREEN ARC, HE IS FLYING AT WHICH OF THE FOLLOWING AIRSPEEDS?

A) POWER-OFF STALLING SPEED WITH THE WING FLAPS AND LANDING GEAR IN THE LANDING POSITION.  
 B) NORMAL OPERATING RANGE  
 C) CAUTION RANGE  
 D) NEVER-EXCEED SPEED



ANSWER  
 B)...CORRECT...THE AIRSPEED NEEDLE WOULD BE IN THE GREEN] ARC TO INDICATE NORMAL OPERATING AIRSPEED.

STAND BY FOR QUESTION #3

Even when the 4051 Graphic Systems are not physically included in an exhibit, chances are that one of the systems contributed in another way. For instance, Otano's staff is also automating the preparation of the basic exhibit script, the labels on the walls and around the displays that add further information to the display. By using Optical Character Recognition (OCR) type on the typewriters, each typewriter in the museum becomes a word processor. They need only type the desired script in the coded characters, then send it out to be automatically read and typeset; type size and style are the only manual inputs. They help eliminate trial and error in the final product by using the 4051 as a previewer. Here they use the graphics capabilities to size up text as an aid to the designer, to help determine in advance the best text arrangement for readability and impact.

### Merging Exhibits With Current Research

Dr. Robert Wolfe is a geologist with the National Air and Space Museum's Center for Earth and Planetary Studies. As a research scientist in the planetary sciences, his primary interest is Mars. His duties as a curator go beyond research, however. Perhaps the most visible of these is creating exhibits for the museum. The intent is to merge his research into the exhibit, in a way that is both interesting and informative to the public visiting the museum. Sometimes the two merge in their 4051 systems.

Six 4051 Graphic Systems are included in the exhibit gallery called "Exploring the Planets." The systems are programmed with a quiz about the display of the planets. The quiz is intended to be more than a fun test after the visit. In fact, it's a learning tool in itself, since the quiz responds to wrong answers with more than just the right answer. The correct answer is displayed, along with information about the incorrect answer, such as possible reasons why it was chosen. To provide this exhibit, Dr. Wolfe wrote a quiz which was then turned into a 4051 BASIC program by museum staff members. But Dr. Wolfe uses the capabilities of the 4051 system in his research, as well as in exhibits.

### Stand-Alone Research

Dr. Wolfe started out as mineralogist and crystallographer, areas where shape and pattern tell a lot. From that beginning, he has developed an interest in shapes and patterns that extends into space. The shapes of craters on planetary bodies are being examined, for instance, for what they can tell about the

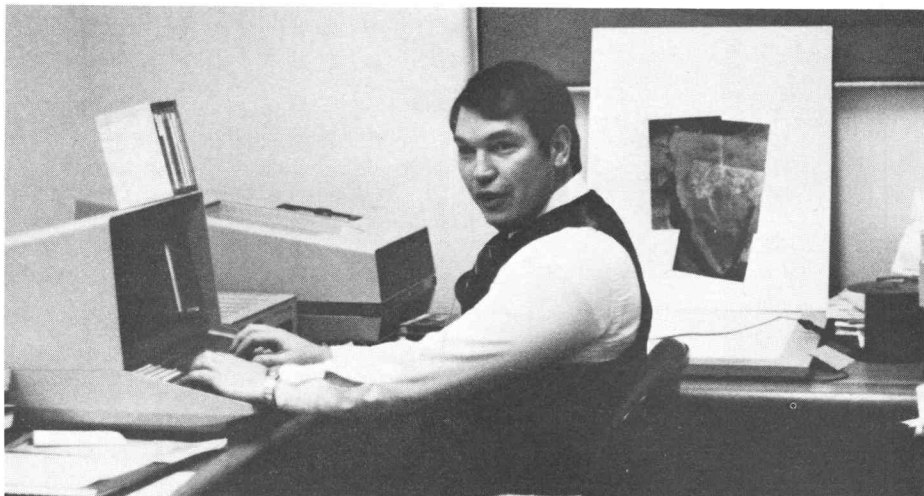

*Dr. Robert Wolfe, geologist for the National Air and Space Museum's Center for Earth and Planetary Studies, employs the 4051 to analyze craters on Mars.*

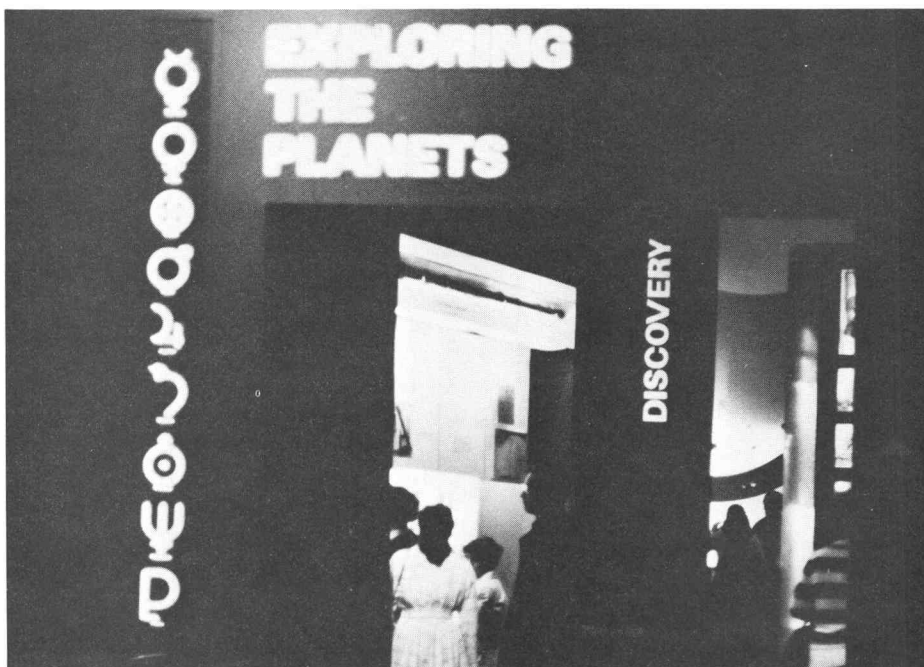

*In addition to his research Dr. Wolfe is responsible for the exhibit "Exploring the Planets."*

### UNUSUAL CRATERS

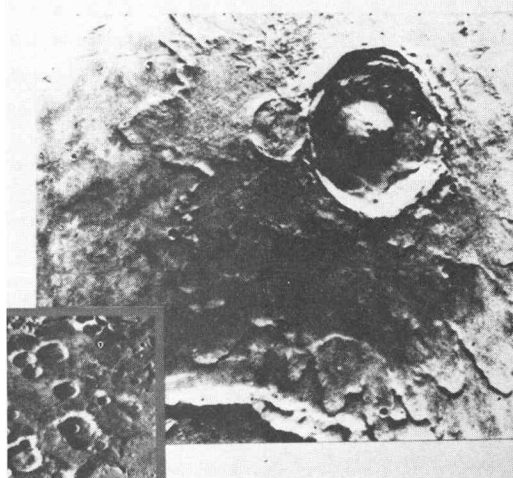

Some martian impact craters, such as the larger ones in this photograph, have unusual patterns of ejecta (material thrown from the crater). More typical impact craters [inset] are shown for comparison.

In the unusual craters, the ejecta appears to have flowed. One theory to explain these craters is that the heat produced by meteoroids striking the martian surface may have melted ice buried in the soil. Water then mixed with the ejecta and caused it to flow.

*Captivating exhibits share Dr. Wolfe's research with Smithsonian visitors.*



And at the end of the exhibit six 4051s encourage the visitor to demonstrate what he has learned.

WELCOME TO THE NATIONAL AIR AND SPACE MUSEUM

EXPLORING THE PLANETS  
 QUIZ SELECTION  
 A...SIMPLE FACTS  
 B...SPACECRAFT FIRSTS  
 C...THE RED PLANET  
 D...THE THIRD PLANET  
 E...GAS GIANTS

SELECT ONE QUIZ BY PUSHING BUTTON A, B, C, D, OR E.

SIMPLE FACTS

1. WHAT PLANET IS THE MOST DISTANT FROM THE SUN?

A. JUPITER  
 B. MERCURY  
 C. VENUS  
 D. PLUTO

THE CORRECT ANSWER IS: PLUTO.  
 FROM PLUTO, THE SUN WOULD APPEAR AS JUST A POINT OF LIGHT.  
 LIGHT FROM THE SUN TAKES 5 1/2 HOURS TO REACH PLUTO, MORE  
 THAN 3.5 BILLION MILES AWAY.

STAND-BY FOR NEXT QUESTION

GAS GIANTS

3. WHICH OF THE FOLLOWING PLANET(S) DOES NOT HAVE RINGS?

A. JUPITER  
 B. SATURN  
 C. URANUS  
 D. NEPTUNE

YOU SELECTED: JUPITER, WHICH IS INCORRECT  
 A RING WAS DISCOVERED AROUND JUPITER BY  
 VOYAGER IN MARCH 1979.  
 STAND BY TO TRY QUESTION #3 AGAIN.

body that caused the crater, and about the surface that the crater occurs in. To analyze these craters, Dr. Wolfe uses his 4051 along with a graphic tablet to input digitized graphic data from photos of planet surfaces.

The crater shapes to be analyzed are caused by the impact of a meteorite on the moon, or Mars, or any planetary body. To give an idea of scale, the craters we're talking about are caused by the hypervelocity impact of bodies that might weigh thousands of kilograms, slamming into Mars at a velocity of 20 kilometers per second. The impact forces that caused the larger ones are calculated in megatons; meteorite sizes range from sub-microscopic to those that might be tens of kilometers across.

To the untrained eye, there might seem to be little difference between one crater and another, except their relative sizes. The planimetric shape of most craters is circular, as they are generally seen. Oblong craters are caused by an oblique impact; these are rare because the meteorite would have to come in at angle less than 15 degrees to the planet surface. But there is a lot of information in those shapes and patterns; they have to be analyzed mathematically or statistically to see what the patterns really are.

And there are a number of algorithms that say something about the circularity of a crater, or any shape that is basically circular. The technique that Dr. Wolfe uses is based upon some work that was done to characterize the shape of sand grains, using Fourier analysis<sup>1</sup>. That work found several parameters that describe the specific shape they looked at. From this, they were able to characterize the various source environments of the sand grains, based on their specific shapes. Freshly eroded material, for instance, is sharper and more angular than sand that has been reworked by years of exposure.

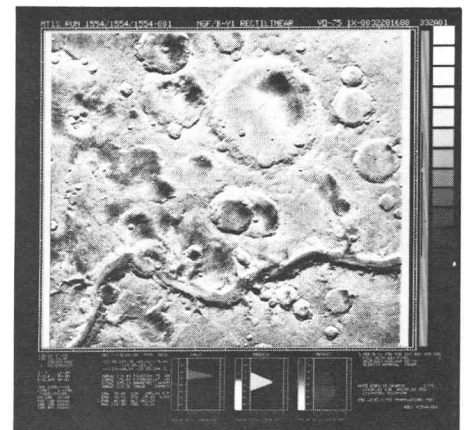

Photo obtained from NASA allows Dr. Wolfe to digitize and analyze craters on Mars.



Dr. Wolfe acquires information for the system by digitizing photographs or photo mosaics from the 4956 Graphics Tablet onto the system tape. That data is then used by his 4051 BASIC program to calculate the Fourier coefficients that will be used for Fourier analysis. (Another program uses some or all of the Fourier coefficients to redraw the shape, if desired.) In general, Fourier analysis recreates any wave form as a sum of several sine waves. In this case, the Fourier Series is not infinite in each direction (as is normally the case in Fourier analysis), but rather has ends that are connected. So this analysis uses polar coordinates, rather than cartesian coordinates.

Since there would be nothing to see if all of the craters were perfectly circular, the analysis looks for aberrations from circularity. There are various results from this analysis. For instance, the calculated parameters can be used as a basis for classifying the craters by type, or for comparing type against size. Eventually, he hopes to expand the analysis to include the crater depth, to see what that will reveal about the geologic characteristics of the impact site. Dr. Wolfe has published several papers concerning craters as probes of a planet's subsurface using other techniques.<sup>2</sup>

In some cases, the effect of the rocks on a crater's shape can be seen easily. For instance, one of the best known craters on Earth is the huge meteor crater in Arizona. Yet when you look at that crater, it seems nearly square. The reason for it's shape is the material in which the meteor impacted; it's rock that is highly jointed, containing lots of fractures and so forth, which have influenced the shape of the crater. Dr. Wolfe's research in this area is continuing; he expects to have a lot of work done, and a lot of information generated, by the end of the summer.

The Museum staff finds a lot of uses for their 4050 Series Graphic Computing Systems, from research to teaching, from discovery to

communication. Dr. Wolfe also uses his 4051 as a terminal, using the Option 1 interface to talk to the museum's Honeywell 6000 series computer; he says he prefers it over the other choices available on the system. Furthermore, he finds 4050 BASIC programming so easy to learn that graphic tasks are easily

accomplished using the 4051's own power. Dr. Wolfe says that new research assistants, even if they have little or no programming experience, can quickly program the 4051. He simply shows them how to Auto Load a tape, hands them the tutorial tape, and says "go." It's been very successful. 

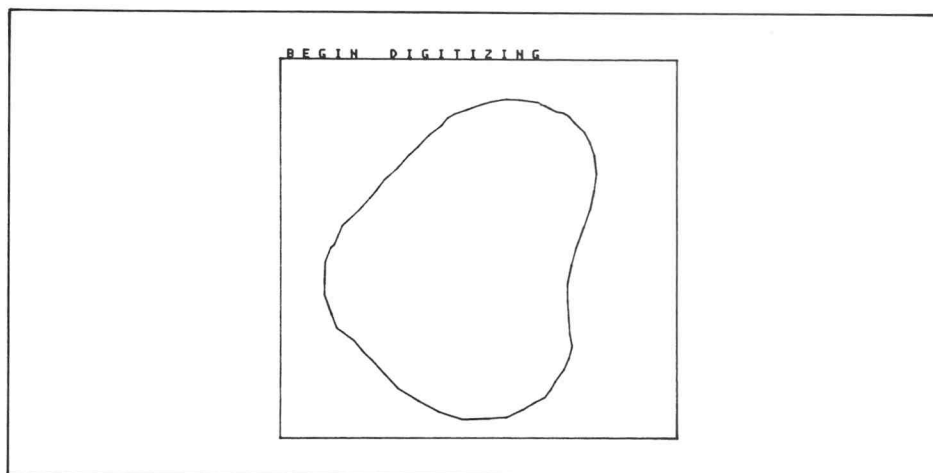

As the crater is digitized from the photo on the 4956 Tablet, its outline is traced on the 4051 graphic screen. Approximately 50 points are input.

CENTER COORDINATES = 0.48 0.47			
AREA = 0.83			
R0 = 0.36			
N	R(N)	RNORM	PHI
1	0.0077	0.0214	201.346
2	0.0620	0.1724	144.693
3	0.0450	0.1252	174.533
4	0.0028	0.0078	94.413
5	0.0037	0.0104	229.946
6	0.0016	0.0045	43.182
7	0.0029	0.0080	322.913
8	0.0016	0.0043	334.948
9	0.0013	0.0036	22.843
10	0.0012	0.0034	252.694

Running a Fourier series computation for unequally spaced data for 10 harmonics on the digitized crater produced the center of gravity, average area and average radius of the crater in the plane of interest. The amplitude, amplitude normalized for an average radius  $R_0$  of one, and the phase for each harmonic was also computed.

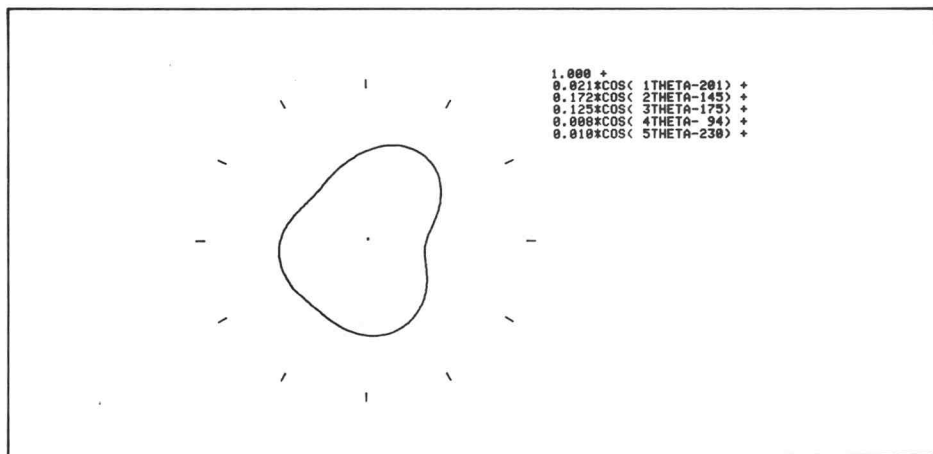

A third program performs a Fourier plot. Here the radius has been normalized to 1, five harmonics chosen with an increment of 2 degrees and the normalized amplitude and phase keyed in for each harmonic.

<sup>1</sup> Ehrlich, Robert and Weinberg, Bernard, "An exact method for Characterization of Grain Shape." *Journal of Sedimentary Petrology*, Vol. 40, No. 1: 205-212, and Eppler, Duane T., Nummedal, Dag, and Ehrlich, Robert, *Impact and Implosion Cratering* (New York: Permagon Press, 1977).

<sup>2</sup> Wolfe, R. W., "Crater morphology and subsurface layering in Mare Crisium (abs.)", *Conf. on Luna 24, The Lunar Science Institution, Houston*, p.204-206. (1977); Andre, C.G., Wolfe, R.W., and Adler, I., "Evidence for a high-magnesium subsurface basalt in Mare Crisium from orbital x-ray fluorescence data", *Proc. Conf. Luna 24*, pp 1-12 (1978).

# Interfacing Contest Entrants Contribute Unique and Ingenious Programs to 4050 Applications Library

by Patricia Kelley  
TEKniques Staff

Thirteen programs entered into the Interfacing Contest sponsored by TEKniques show once again the wide variety of applications and ingenuity of 4050 Series users.



## First Placings

Acquiring spectrophotometric data over the GPIB, automating FFT operations through the Option 1 Data Communications Interface, and sending digitized, scaled output over a specially built interface have earned users at the University of Tennessee, Virginia Polytechnic Institute and State University, and U.S. National Oceanic and Atmospheric Administration first prizes in the contest.

R.J. Peterson, D.L. Raschella, and J.R. Uchida developed the "On-Line Spectral Analysis" program in their work at Oak Ridge National Laboratory studying the basic properties of elements produced in nuclear reactors. An article detailing their application is included in this issue of TEKniques.

L.D. Mitchell, John H. Herold, and Donatus C. Ohanehi use a 4051 and Zonic Technical Laboratories 5003 FFT processor at the Department of Mechanical Engineering. Their program, "Controlling FFT Operations from Tape," speeds up their work remarkably.

William M. Retallack and John H. Taylor designed the special "20 ma Current Loop Interface" to send data to a Model 33 Teletype to reduce hard copy costs.



## Second Placings

D.L. Raschella, J.R. Uchida, and J.R. Peterson also garnered second place in the GPIB category. Another segment of their work at

Oak Ridge National Laboratories determines the heat liberated from transplutonium element samples when dissolved in a liquid. From this they developed the "On-Line Calorimetry Data Acquisition and Analysis" program.

Finding a method to track location graphically using a LORAN-C Receiver inspired Peter G. Mauro's "LORAN-C Receiver Interface to 4050." This application was detailed in TEKniques Vol. 3 No. 7.

The National Oceanic and Atmospheric Administration also captured second place in the special interface category. Animating graphs to show motions of particle populations in the earth's magnetosphere as a function of time led to the "Camera Triggering Circuit" interface sent in by William Retallack and Steven Fahnenstiel.



## Third Placings

From Dr. John Rolfe at the National Research Council at Ottawa, Canada, comes a program to control a digital voltmeter, Hewlett-Packard Multiprogrammer and optical apparatus through the GPIB. "Measurement of Absorption Spectra" also plots the acquired data on the 4050 screen, records it on the 4907 disc and prints it in tabular form.

Chuck Paulson who is in the Instrument Products, Biomedical Division, of E.I. DuPont Company has developed programs to drive an IEE-ARGUS Plasma Dot Matrix Display through the Option 1 Data Communications Interface. The "IEE-ARGUS Display Subsystem Interface" has proven to be a popular attention-getting application.

At the University of Oregon, Barry T. Bates is engaged in the study of biomechanics. Some of his subjects are athletes, construction workers and those injured on the job. Through his work he has evaluated running shoes, influenced new work habits and has developed legal evidence. He uses the "A/D Sampling and Modification" program to acquire data through a special ROM pack.



## Runners-Up

### GPIB

Barry Bates also contributed "Digitize and Modify Data" which brings data in from a digitizer over the GPIB, another program used extensively in his biomechanical studies at the University of Oregon.

An in-depth evaluation determining the capability of the Hewlett Packard 9835 and TEKTRONIX 4051 to communicate prompted the GPIB program sent in by Robert Cope of Atlantic Analysis Corporation.

### Option 1 Data Communications Interface

Several programs allowing the 4050 to interface with an Amdahl 470 V/6-II and a Hewlett-Packard 9810A programmable calculator were entered by Subarna B. Malakar at the State of Florida's Department of Natural Resources.

### Special Interface

"Two Factor Repeated Measures and Independent ANOVA" analyzes two factor repeated measure designs using an auxiliary memory manager. This program also arises from the work being done by Barry Bates at the University of Oregon's Department of Physical Education.

Detailed abstracts of all contest entries are included in the New Abstracts section of TEKniques.

### Support is Appreciated

We regret that prizes could not be given to all who entered the contest. The applications were good and kept the judges busy making their placings. 4050 Series users will benefit immensely from these programs, and the time the entrants took out of their busy schedules to document and send in their programs is sincerely appreciated. 

# Transparency Kits Available for Presentation Aids Slides

by **Byron Fisher**  
Tektronix, Inc.

Those of you who are using 4662 Digital Plotters are already aware of the way they condense computer data into presentable graphic information quickly and economically...directly onto paper. And many of you are using Slidemaker II, Presentation Aids II, or other 4050 Series Applications Library software to make plots, or even overhead transparency slides. As an aid in such applications, the Tektronix Transparency Kit is now available.

Designed for use with the 4662 Plotter, the kit allows you to produce colorful professional-looking overhead projection transparencies quickly and economically. Every plotter operation, from graphics to alphanumeric, can be imaged directly onto ready-to-project transparency film with the kit's contents. The resulting transparencies are stimulating, effective visuals that communicate powerfully in meetings and presentations.

The Transparency Kit contains all of the easy-to-use materials and how-to information that you'll need to add colorful impact to plotter-prepared overhead projection transparencies. Regardless of your subject area—technical, financial, educational—you'll add a brilliant new dimension to your total operation by professionalizing your presentations.

The Transparency Kit (Tektronix Part No. 020-0595-00) contains the following material:

Pre-framed	
Plotter Film	200 sheets
Plotter Pens	
black	1 pack (3 pens)
red	1 pack (3 pens)
green	1 pack (3 pens)
blue	1 pack (3 pens)
Solvent	1 bottle
Colored Background	
Film	
yellow	25 sheets
blue	25 sheets
Bar Graph Adhesive	
Strips	1 pack (6 pads)
Color Adhesive	
Film	
red	5 sheets
green	5 sheets
Transfer Symbols	
red	1 sheet
black	1 sheet
Pencil Knife	1
Visual Marking Pens	
(hand-held)	1 pkg (5 pens)
"Adding Color	
Impact" (booklet)	1

The pre-framed plotter film is 7 mils thick for easier use. The color background film adds solid colors for effect, while the bolder color adhesive film and bar graph adhesive strips add emphasis for brilliant visuals. Color mylar plotter pens are included, as well as hand-held marking pens to add emphasis to key points during or before a presentation.

The Tektronix Color Transparency Kit has everything you need to prepare the quality presentation aid you've wanted. For the complete story, contact your local Tektronix representative. Or call our toll-free automatic answering service at 1-800-547-1512. (Oregon residents call 644-9051 collect.) 

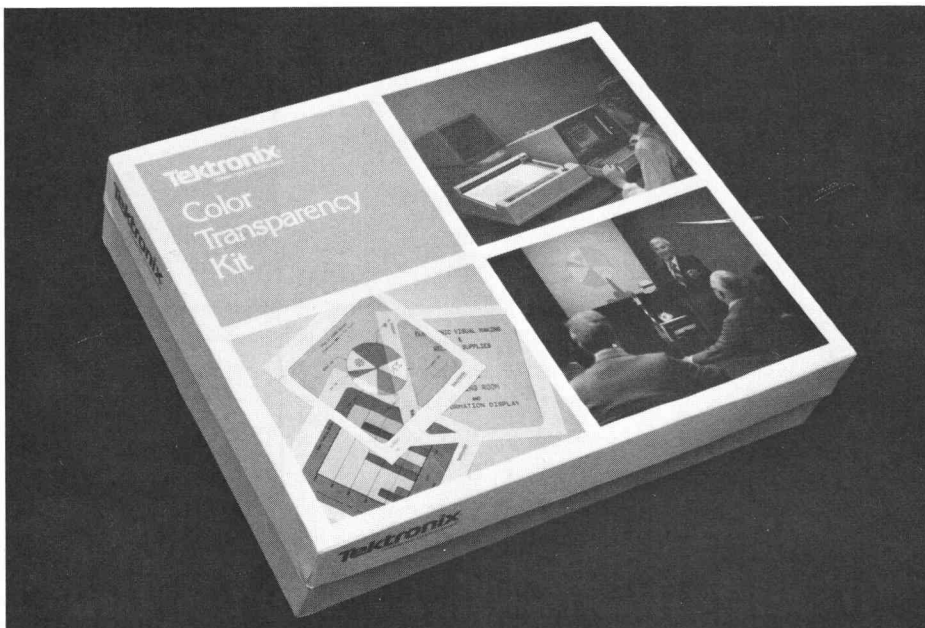

# 4051 Aids in Study of Radioactive Elements

by **D.L. Raschella**  
**J.R. Uchida**  
**J.R. Peterson**  
University of Tennessee  
Knoxville, Tenn.

## Background

The University of Tennessee participates in an ongoing national program to study the basic properties of elements produced in nuclear reactors. Dr. Peterson's group concentrates on the determination, interpretation, and correlation of the fundamental chemical and physical properties of the transplutonium elements. The elements include americium, curium, berkelium, californium, and einsteinium. Due to the availability of these elements at the Oak Ridge National Laboratory (ORNL) and the special facilities required to handle radioactive materials, our research is performed in the Transuranium Research Laboratory at ORNL. We'll report two of our investigative techniques that make significant use of a Tektronix 4051 Graphic System. This article describes the absorption spectroscopy program, while another details the 4051's role in our solution microcalorimetry research (to be published in the next issue of *TEKniques*).

Absorption spectroscopy is a widely employed analytical technique to characterize and to identify chemical compounds. Chemical species absorb light radiation in characteristic ways as a function of the wavelength of the light. Measurement of this characteristic absorption produces an absorption spectrum which serves as a "fingerprint" of that particular chemical species.

We use a unique application of absorption spectroscopy in the study of transplutonium element compounds, to follow their radioactive decay. Since radioactive decay can change one element into another, we can monitor with time the disappearance of the unique spectrum of the "parent" species and the ingrowth of the spectrum of the "daughter" species.

A spectrophotometer capable of focusing light onto an extremely small area has been constructed at ORNL. It's called a micro-

scope spectrophotometer since it employs microscopes both to focus the light striking our (typically) microgram-sized samples and to gather the light passing through the samples. A schematic diagram of the microscope spectrophotometer is given in Fig. 1.

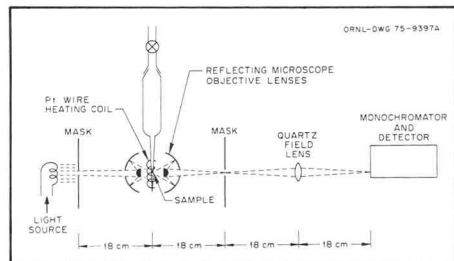

Fig. 1. Schematic diagram of microscope spectrophotometer.

The 4051 gave a tremendous boost to the spectroscopy program. It provides for a more-thorough analysis of the data, and greatly increases our productivity. Whereas before it took at least one day to collect the spectral data and to obtain a high-quality plot of the absorption spectrum, now with the 4051 the time is reduced to less than an hour! With the acquisition of a 4631 Hard Copy Unit to provide intermediate results, and a 4662 Interactive Digital Plotter for final plotting of the spectrum, our in-house graphics capability and flexibility greatly increased. The 4051 system is now indispensable in this program. Figure 2 shows Dr. Raschella with the microscope spectrophotometer and 4051 system.



Fig. 2. Microscope spectrophotometer and Tektronix 4051 system.

## System Hardware and Configuration.

Spectral information is obtained by digitizing the output of the photo-multiplier tube (detector) with a Dana Model 5000 digital voltmeter (DVM). The DVM is interfaced indirectly to the 4051 through a Dana Model 55 microprocessor, which converts the voltmeter's BCD output to the IEEE-488 standard; all interfacing is achieved through the GPIB. Data are collected on a real-time basis through the use of a TransEra Model 641 real-time clock, which is connected to the 4051 through a ROM port.

Data acquisition is under program control, with a wide range of available scanning rates. The configuration of the system hardware is shown in the block diagram in Fig. 3.

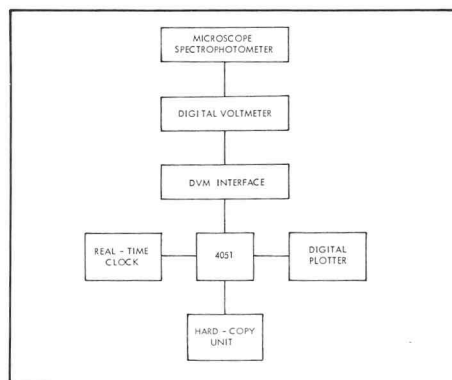

Fig. 3. Block diagram of system hardware configuration.

## On-Line Spectral Analysis Software.

The spectroscopy program is divided into four segments, each performing a specific function. These segments consist of the input, baseline fit, plotting, and display/edit routines. At the end of each segment the operator can initiate the overlaying of the next segment or branch to any other segment, simply by depressing the appropriate User-Definable Keys. An example of the acquisition and plotting of an absorption spectrum and a brief description of each program segment follow.

Loading the resident program initializes variables and appends the input (acquisition) routine. Prompts generated by the 4051 program are preceded by an asterisk and appear on the right side of the 4051's CRT; program status and general information appear on the left side of the screen. Figures 4 and 5 are examples of the CRT display when a sample spectrum is obtained. Scale changes are effected in the photomultiplier tube output amplification by turning a knob on the power supply/amplifier of the photomultiplier tube. These scale changes are marked in the digital data by depressing User-Definable Key 6 simultaneously with the manual adjustment of the knob on the power supply/amplifier.

```

* Enter 0 (to examine old file)
  or N (to create a new file) N
* Insert Data Tape
* Enter File Number
  to Store Raw data: 1
* Enter Spectrum Sample ID Number
  3903010000
* Enter Initial Wavelength
  (in Angstroms): 11000
...DELAY: 42
...Ready
...Scale Changes: 0 1 2
...End Of Scan
NUMBER OF DATA POINTS: 1576
* Enter Final Wavelength
  (in Angstroms): 3000
  
```

Fig. 4. User-definable keys' overlay card for spectrophotometer program.

```

3903010000
-----
Data Range (A)  No. Pts.  Increment (A)
-----
11000 - 3000    1576    5.0761
...Data Transfer To Tape File 1 complete
* Is This a Fluorescence Spectrum? N
  
```

Fig. 5. Spectral data summary and transfer of data to magnetic tape.

The end of the spectral scan is signaled to the 4051 by applying a larger-than-normal voltage across the voltmeter terminals. This is done by depressing a button on the photomultiplier tube power supply/amplifier and noting the wavelength of the monochromator at that moment. The voltage-time data are stored in memory until the spectral scan is completed and are then transferred to magnetic tape. A spectrum identification number, initial and final

wavelengths, and tape file number are entered by the operator. Since the monochromator scans the range of wavelengths at a constant rate, a simple program calculation converts the voltage-time output to voltage-wavelength data. Position and direction of scale changes are then displayed (Fig. 6). The

```

SCALE CHANGE SUMMARY
-----
DISPOSITION: M(more) L(less) D(delete) net(ok)
SC  PT #  VALUE  ML(A)  SENS  DISP
---  ---  ---    ---    ---   ---
1   1302  0.001000  4392  MORE  1:
2   1584  0.001000  3366  MORE  2:
3   1575  0.017232  3005  LESS  3:
List,Continue,or Save? C
SCALE CHANGES
to MORE sensitive scale: 4391 A at:1302
to MORE sensitive scale: 3365 A at:1584
* Enter Number of Points to Interpolate at Scale Change: 5
* Insert Program Tape
* Push Return for Baseline Fit or use User Def Keys
...Append Baseline Fit
  
```

Fig. 6. Summary of scale changes.

operator has the opportunity to alter or delete a scale change, in case an error was made during the data collection. Points around scale changes can be smoothed by interpolation of data points further away from the scale change.

Since our microscope spectrophotometer is a single-beam instrument, the observed sample spectrum must be corrected for contributions of the background. A baseline spectrum is obtained by running the spectrophotometer with an empty sample container. Several "standard" baseline spectra have been generated and are stored on tape, so the operator selects the most representative of these to serve for background removal, as shown in Fig. 7. The absorbance

```

BASELINE FITTING
-----
* Insert Baseline Tape
* Enter Baseline File: 0
ID NUMBER  DATA RANGE (A)  NO. PTS.
-----
BASELINE  4702010000    11000 - 2900    1618
SAMPLE    3903010000    11000 - 3000    1576
...Begin Fit
...Background Removed
* Insert Program Tape
* Press Return to Display or use User Def Keys
...Append Edit/Display Routine
  
```

Fig. 7. Example of baseline fitting routine.

(abs) of the sample as a function of wavelength ( $\lambda$ ) is then calculated by means of the relation.

$$\text{Abs}(\lambda) = \log \left\{ \frac{\text{Background voltage at } \lambda}{\text{Sample voltage at } \lambda} \right\}$$

The next section of the program, the display/edit routine, displays the absorption spectrum (absorbance vs wavelength in Å) on the 4051's CRT. Fast plot (Option 9 of the program) permits a quick review of the spectrum by plotting only every tenth point, as illustrated in Fig. 8. Higher resolution is

achieved by requesting option 2, which displays all data points (Fig. 9). Additionally, selected areas of the spectrum may be viewed separately, as shown in Fig. 10.

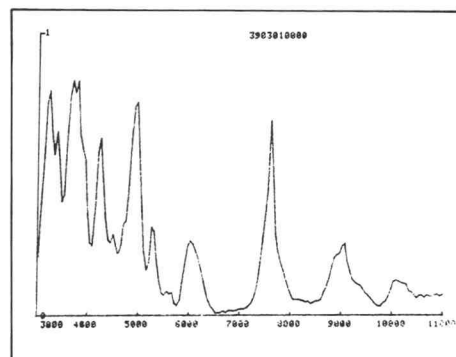

Fig. 8. Fast plot of sample spectrum 3903010000.

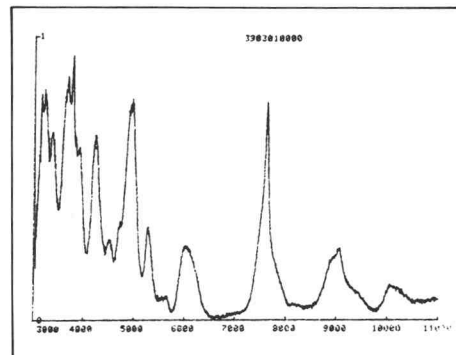

Fig. 9. Full resolution plot of sample spectrum 3903010000.

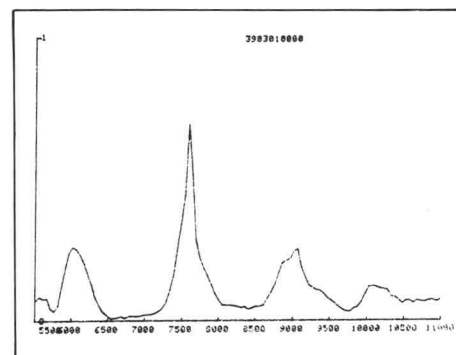



Fig. 10. Fast plot of expanded wavelength section of sample spectrum 3903010000.

Superior graphics, suitable for publication, are possible with the digital plotter. Option 7 appends the plotter routine. This routine is equipped with sufficient parameters to display the spectrum in a variety of styles. In addition to plotting the complete spectrum, sectional plots may be produced.

Expansion is possible in either the x or y direction. Absorbance and wavelength limits and absorbance step size (tic marks) can be operator specified or set automatically by the program. Up to four spectra, complete with titles, can be plotted on the same graph. The

plot shown in Fig. 11 is the absorption spectrum of einsteinium trifluoride ( $\text{EsF}_3$ ). For a more aesthetic presentation the spectrum can be flattened further. The line segments to which the spectrum will be flattened are selected either from the CRT with user-definable keys 1-5, or from the plotter by employing the GIN command. Upon flattening the  $\text{EsF}_3$  spectrum shown in Fig. 11, the spectrum reproduced in Fig. 12 was obtained. In addition, spectra can be normalized to any specified absorbance value, an option of particular use in our studies to follow the radioactive decay of transplutonium element samples. 

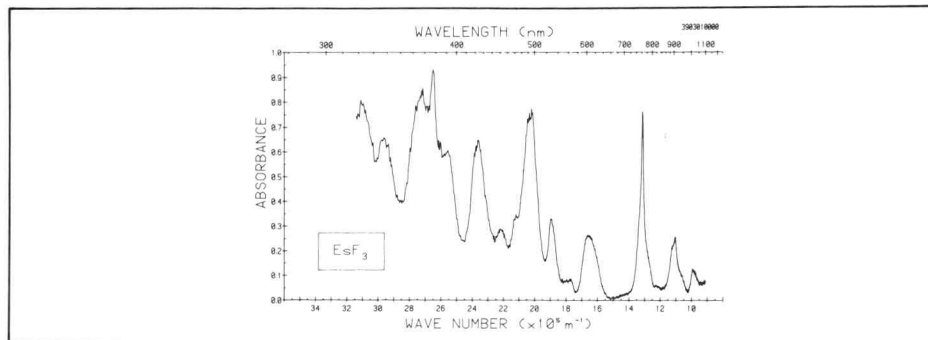

Fig. 11. Absorption spectrum of  $\text{EsF}_3$  .

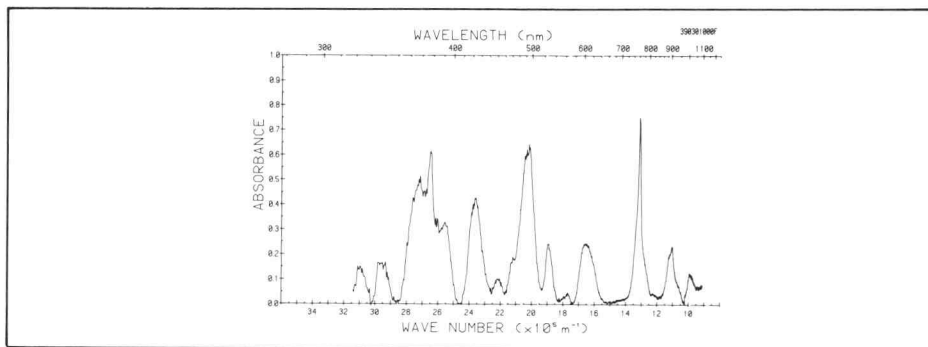

Fig. 12. Absorption spectrum (flattened) of  $\text{EsF}_3$  .



## System Makes Signs for Rose Show

by Terry Davis  
TEKniques staff

Most times, we find very serious uses for our 4050 Series Graphic Computing Systems, in research, in education, or in industry. But sometimes applications arise that are not in the mainstream, yet are important and bring enjoyment as well. Such is the case in a local application that recently came to our attention. The application is at the Portland Rose Society, for use in their Portland Rose Show. The show takes place in conjunction with the Portland Rose Festival.

The Portland Rose Festival has been a part of each June's festivities since 1907; the Portland Rose Society, which sponsors the Rose Show, predates the Rose Festival by 19 years. Most of the entrants in the Rose show are amateur gardeners from the local area, although entrants come from as far away as Montana and British Columbia.

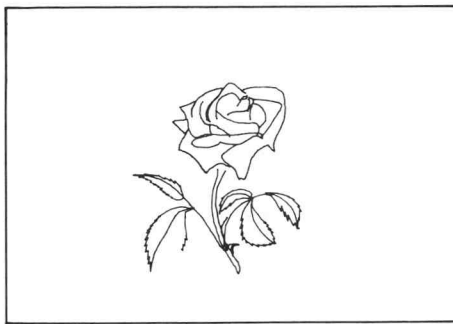

Fig. 1. The Portland Rose Society employs a 4051 to plot the roses for its Portland Rose Show exhibit tags.



SAPPORO TROPHY COMPETITION

Fig. 2. Incorporating the plotting program with a sign-making program results in a low-cost, unique label.

Last year the society again went to look for some signs that could be printed at a reasonable price; signs to be used to identify the roses and the growers in the many exhibits. When the lowest price seemed more than the society wanted to pay, an alternative was hit upon. Al Schamel, a Tektronix employee and present Rose Society president, suggested using a 4051 with a 4662 plotter. With that system they would be able to generate their own signs.

George Reis, also of Tektronix, generated a program to digitize a picture in two parts, so that it could be plotted out in two parts (and two colors). Al used the program to digitize a rose picture, and the resulting plot (Fig. 1) was used along with a sign-making program to create exhibit tags like the one shown in Fig. 2. The stems, of course, are plotted in green, while the rose color can change with the color theme of the Rose Show itself. And the appealing signs, with a little volunteer effort, were generated at less cost than the estimates for printed signs.

Last year's exhibit tags featured red roses, and were a big success. So much so that the program was called back this year for a

second appearance, plotting this year's yellow roses. This just goes to show that anywhere graphics are needed, the 4050 system can fill the bill. 

# Editor's Note



## Our Smithsonian Features

This issue features two articles about the Applications for 4050 Series Graphic Computing Systems at the Smithsonian Institution. Our interest was aroused when Dave Barnard, from the Tektronix Wilsonville offices, visited the National Air and Space Museum and submitted the first article on their applications. Pat Kelley, TEKniques Managing Editor, followed up with a trip to the Washington, D.C. area to look at the Smithsonian applications, and others, in more detail. We hope you enjoy these articles; perhaps you'll want to see these systems for yourselves.

We'd like to thank Steve Swindell of the Tektronix office in Rockville, MD, for his assistance in making arrangements for the visit. In addition, we'd like to thank Hernan Otano, John Hartman, Dr. Richard Benson, and Dr. Robert Wolfe, for giving their valuable time during the visits, and for their assistance in preparing our articles.

## Contest Winners Too

In this issue you'll also find the winning entries in the Interfacing Contest, in the New Abstracts section. In addition, there are brief biographical sketches of the winning entrants. We had a lot of very good entries in the contest, adding several excellent programs to the library. In fact, there were so many from the contest that we were unable to find space for all of the other new program abstracts in this issue. Those, however, are documented in the new Applications Library Catalog.

## Programming Tip Handbook is Coming

We're in the process of preparing a handbook of Programming Tips from the first three volumes of TEKniques. Our question-

naires, and other comments from library members, show that the Programming Tips are very popular, widely read, and often referred to. So we're collecting the tips from 1977-1979, to be published as a volume. Corrections from subsequent issues are being incorporated in the reprinted tips.

We expect the Programming Tip Handbook to be very popular; you may want to reserve your copy in advance. To get your name on the advance list, write to the address of the Applications Library serving you. The Programming Tip Handbook will be included in the Applications Library as reference material. Refer to number 51/00-7004/0 in your correspondence; the U.S. domestic price is \$10.

## Plot 50 Users?

Are you using TEKTRONIX 4050 Series/Plot 50 Software? If you are, we'd like to hear about your application as a potential feature article for TEKniques. 4050 Series/Plot 50 Software is designed to be flexible enough to fit lots of requirements; we'd like to print an article (or more) that shows what the software is capable of doing, by showing what you're doing with it.

If you would like to contribute information about your application, for an article in TEKniques, drop us a line at the TEKniques United States office, to the attention of the editor. We'll help you write the article, to whatever level you need. And we'll be very grateful for the assistance.

## Wanted: More Programs

The Applications Library staff is always looking for more programs to add to the 4050 Series Applications Library. By keeping the library growing in this way, we are able to aid more users by providing a bigger

base of information for all to share. And, of course, the source of more programs is you, the users who write them.

If you'd like to contribute your program to the library, refer to the information at the beginning of the Abstract section for instructions. And remember, you get three programs for each one accepted by the library, so you can't lose.

## Programming Tips

We'd also like to remind you that we're looking for your Programming Tips and BASIC Bits as well. You'll receive any one of 12 programs from the library in exchange for each of your Tips/Bits. Details are listed at the end of the BASIC Bits column in each issue.

## Your New Catalog

Your new 4050 Series Applications Library Catalog arrived accompanying this issue of TEKniques. It contains 66 new program abstracts, bringing the total number of library programs to 192.

We've also updated most of the previous abstracts. We went through the abstracts and compared them with the programs to find additional information that needed to be documented. Hopefully, we have pointed out the programs' features and limitations in the new edition. But since we can't be experts in all fields, your comments on individual abstracts (something missing when you received the program, etc.) would be helpful for others. Let us know about any such problems and we'll update the abstract accordingly.

In addition, if you should find a bug or a wrong formula in any program please let us know. We'll refer it to the author for necessary corrections. 



# INPUT / OUTPUT

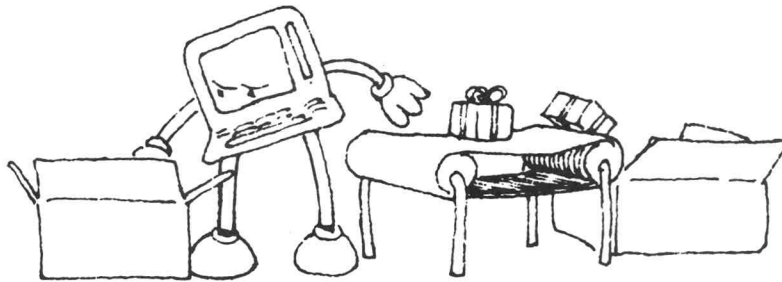

Nicholas Gessler, Paleosystems, Queen Charlotte City B.C., Canada, sent in his question about memory. Dan Taylor, Design Engineer at Tektronix and TEKniques' Technical Editor, explains.

I have had some problems when approaching a full memory on a TEKTRONIX 4051. The problem is infrequent, but nevertheless disconcerting.

While editing a large program the MEMORY FULL error message appeared. The use of edit keys and RUBOUT, the DELETE (line number), and (line number) RETURN procedures all failed to delete memory space with the MEMORY FULL message appearing after each attempt. LIST would give the same message as did all the other commands which I tried including immediate mode commands such as 2 plus 2 RETURN. The AUTO NUMBER key was the only way to read the program.

The problem worsened as I typed random three letter commands to the 4051: The first brought a SYNTAX ERROR. I cleared and typed in FON expecting another SYNTAX ERROR. At this point the cursor disappeared and the keyboard would not respond. The BREAK key caused the BREAK light to go on but the keyboard would still not respond.

Finally, after trying other keys, each eventually resulted in a BELL tone indicating, I assume, that the keyboard buffer was full. All keys produced this tone except MAKE COPY.

I eventually gave up, powering down, and losing all memory. Is there any way to recover from a memory so full that it apparently won't even delete.

**In program mode, when the 4051 sees that it is running out of memory, it will print the**

**memory full message on the screen. However, there should still be enough bytes left for you to take steps to save your program. These steps were outlined in TEKniques Vol. 2 No. 5. A step not mentioned is to key in INIT which would delete your variables (arrays and strings) and recover memory.**

**However, if the 4051 runs out of memory outside of program mode, there may not be enough bytes left to salvage anything. For example, if you have a large program in memory and are editing it—changing or inserting code—you could fill memory to the brim. The 4051 looks at the statement you are inputting. If it will overflow memory, you will receive the memory full message, but there will still be enough bytes to recover. However, if a statement doesn't exceed memory, it will be accepted, but there may not be enough bytes left to do any more editing.**

**Also, if you have a program in your 4050 system which is using almost all of memory and you key in strings or variables in immediate mode (without statement line numbers), you could also fill memory.**

**Other than breaking a program into smaller modules, the way to avoid overflowing memory when keying in a program or editing, is to use the MEMORY function once in a while to check to see how close you are to filling memory. Other safeguards are to periodically save your program (this will also save you in case of power failure). Use two different files to save it. If you only had one file and power failed while you were saving it, everything would be gone. And, when you save your program, check MEMORY at the same time.**

**James Okvist of Raytheon Company in Bedford, MA, is the new owner of a 4054 Graphics System. His questions relate to using the 4054 with existing programs run-**

ning on a large CYBER host. His programs currently use a TEKTRONIX 4014 terminal with tablet as the graphics hardware. They use TCS software for graphics output. Howard Sanders, Technical Support Specialist at Tektronix, Wilsonville, responds.

How do you record 4014 compatible graphics (received over the Option 1 RS-232 Interface) on the internal tape drive of the 4054 and redisplay the graphics under control?

The graphics (data) received on the screen of the 4054 from the host can be diverted to the internal tape drive. However, first the three environmental parameters in the routine CALL "RSTRIN" must be set up. These parameters define the character strings which will be sent from the host to tell the 4050 System:

- 1) prepare to receive and store a record on tape.
- 2) end of logical record
- 3) end of transmission

You can set the first two parameters to no characters, but the last parameter must be known and specified. For example, CALL "RESTRIN", "", "", "\*\*\*\*\*" would allow the 4050 System to accept any data coming from the host in one long string (no delimiters between records) and when it received the four asterisks prompt, stop receiving data.

If the host's prompt is unknown, have the host send the data to the screen after pressing UDK #11.<sup>1</sup> Look for the last character printed after the file is transferred, e.g., a ,\*\*\*\*, # or some such.

Now, once you've set up your normal parameters and CALL "RSTRIN" then type in CALL "TERMIN". Press UDK #13, enter

<sup>1</sup>Pressing UDK #11 before receiving data from the host allows the control characters to be printed on the screen, except carriage returns.

the file number in which to save the data and press RETURN. Enter the command to the host to send the data file and immediately press UDK#3 (don't press RETURN).. The host will send the file directly to the 4054 tape. (Be sure your file is MARKed long enough to hold the data.

There are two methods to display the graphics under local control. The first uses the self-test adapter which accompanies every Option 1 backpack. Plug in this adapter as described under CALL "CMTEST" in the option 1 Manual. Type in CALL "TERMIN". Press UDK #16 to set ECHO OFF and press UDK #1 to execute control characters received. Press UDK #13, enter the file number in which your data is stored, and press RETURN. Now press UDK #4 and the graphics will be sent to the 4050 Screen. Rather than pressing the User-Definable Keys, these steps could be accomplished by a small program running in your 4050 System.

```

100 INIT
110 CALL "RATE",1200,0,2
120 CALL "MARGIN",0,0,0
130 CALL "RCRLF",1,2,0
140 FIND 1
150 CALL "DSEND"

```

The graphics may be displayed at the highest baud rate.

The second method is quite a bit slower but doesn't require the Option 1 backpack and self-test adapter. It uses software to interpret the data into graphics. A program is in the 4050 Series Application Library, 51/00-9542/0, "4010 Style Graphic Character Data to GDU Conversion Routine" which accomplishes this.

Can you accept TCS output data over the Option 1 RS-232 Interface and divert the alpha portion to the Option 10 Interface while displaying the graphics portion on the 4054 display? This capability would allow a program to display the user dialogue on a printer while keeping his screen clear for graphics. Are there problems if the program communicates with the display at a higher baud rate than the Option 10 Interface can handle?

This is possible although it will require a modification to your host program. The 4050 Series has the unique ability to return to a resident BASIC operating program after entering terminal mode if it receives from the

host two consecutive "ESC" characters. Using this ability and a small program in your 4050 System, you can divert the alpha characters to the Option 10.

The following routine suggests a method to accomplish this. Statement 130 transfers control to the host. In your host program send two "ESC" characters to the 4054 prior to sending the alpha characters. This will return control to the 4054 at Statement 140. It will transmit the incoming data over the Option 10 (address 41 or 51) until it receives a terminating character, e.g., DONE in this case. This will prompt the 4054 to return control to the host.

```

100 INIT
110 PRINT @40,30:
120 CALL "RATE",2400,0,2
130 CALL "TERMIN"
140 INPUT @40:A$
150 IF A$="DONE" THEN 130
160 PRINT @51:A$
170 GO TO 140

```

This could be elaborated upon but these few lines give you the essentials from which to work.

The Option 10 can communicate at the same baud rate as the Option 1. However, the printer may be too slow to keep up with the host if it's transmitting at a high rate, resulting in data loss. Note: The 4050 Series tries to prevent data loss by providing a buffer area (up to full memory) which should accommodate most applications.

Can the host computer initiate a BASIC program on the 4054? We would like to emulate the tablet handling of a 4014 with a 4054 display and tablet on the GPIB interface. To allow for minimal user re-education, we prefer to control the display and tablet from the host rather than locally.

The BASIC program could be initiated with the same technique mentioned above. And while the 4054 program is running, it could also monitor the host for further instructions. Simply have the program in the 4054 routinely do an INPUT @40,0:A. This will return the number of CR's in the RS-232's input buffer. If that number is above 0 then the host is asking for a response. An INPUT @40:A\$ could then be done for instructions and the correct subroutine branched to in the 4054 program.

The tablet handling can be done in much the same way. It would require prompts in your host program in the appropriate locations

and a program similar to the one described above. With this type of programming the user would hardly notice a difference.

Editor's Note: For relative information refer to the programming tip in TEKniques Vol. 4 No. 1, p. 11, "Buffering Data Received Over the RS-232."

What is available for paper tape punch hardware and software to be driven on the GPIB bus?

TEKniques Vol. 1 No. 7 described the FACIT Paper Tape Punch and Reader and where to get more information. Software examples were included. 

# PLOT 50 Easy Graphing: Command Files

by Patricia Kelley  
TEKniques Staff

with Howard Mozeico  
Tektronix, Inc.  
Wilsonville, OR

Easy Graphing is the new and versatile PLOT 50 graphing package. TEKniques Vol. 4 No. 2 carried an overview of its capabilities. Vol. 4 No. 3 took an in-depth look at its commands. This article will discuss one of its most powerful features: Command Files.<sup>1</sup> And in conjunction with Command Files, we'll also use a couple of the UTILITIES routines.<sup>2</sup>

As you become familiar with Easy Graphing's capabilities and commands, you may extend your productivity through Command Files. Command Files allow you to specify a graph's format and then turn it over to others for periodic graphing with revised data. Your Command File(s) automatically handles the details according to your specifications but the task of keying in data may be handed to someone else.

As an introduction to what a Command file (or RUN file) is, let's look at one created automatically by Easy Graphing. When you SAVE a graph, Easy Graphing figures out what commands are required to re-display that graph and stores those commands along with your data and graph parameters. When you retrieve that graph (by typing RUN username), Easy Graphing locates the file on the disc, opens it and begins executing the commands.

For example, in the last Easy Graphing article the following commands created a graph and saved it as PERSINCOME.

```
ENTER MAIN 2419,4245,6030,7183
ENTER NEBR 2089,3657,5882,6720
ENTER IDMO 1812,3243,5179,5988
ENTER YEAR 1968,1970,1975,1977
GRAPH YEAR MAIN NEBR IDMO

VRANGE 1500,7500
XRANGE 1955 1980;XTIC 1955 5
SYMBOL 1 4;LINE 2 1;SYMBOL 2 5
BAR 3 3;BAR WIDTH 1
LEGEND 1 "Main";ILEGEND 2 "Nebraska"
LEGEND 3 "Idaho"
LEGEND 4 "Washington"
LEGEND 25 90
TITLE "PERSONAL INCOME PER CAPITA"
DATE "Data for Years 1968, 1970, 1975, 1977"
XTITLE "From STATISTICAL ABSTRACT OF THE UNITED STATES"
YTITLE "Dollars"
ENTER YR2 1960 1970 1975 1976 1977
ENTER WASH 2688 4317 6518 6772 7820
GRAPHIS 1
ADD YR2 WASH;LINE 4 1;SYMBOL 4 3;LEGEND 4 "Washington"

SAVE PERSINCOME
```

Fig. 1. The Easy Graphing commands above were keyed in for a custom-designed graph titled "PERSINCOME."

Using the Easy Graphing UTILITIES LISTING routine (not the Easy Graphing command LIST), we can look at PERSINCOME (or any file on the disc saved by Easy Graphing). To invoke this routine, type.

## UTILITIES LISTING

Easy Graphing prompts for the name of the Command (RUN) File.

```
EASY GRAPHING "LISTING" UTILITY
Do you want to list all RUN files (Yes, No or Exit) default No: NO
Do you want to specify the file names (Yes, No or Exit)
default: No: YES
Enter the name of the RUN file that you wish to list (RETURN if
done): PERSINCOME
```

then lists the contents of the file. The listing of PERSINCOME shows the series of commands Easy Graphing stored to reconstruct the graph. Compare the order of commands with how they were entered above; Easy Graphing optimized the command order when it SAVED the graph. Note that commands may be abbreviated, e.g., TITLE to TI, and so on.

```
Page 1 of PERSINCOME 28-MAY-88 10:17:00 AM
ENTER MAIN 2419 4245 6030 7183;4
ENTER NEBR 2089 3657 5882 6720;4
ENTER IDMO 1812 3243 5179 5988;4
ENTER YEAR 1968 1970 1975 1977;4
ENTER YR2 1960 1970 1975 1976 1977;4
ENTER WASH 2688 4317 6518 6772 7820;4
GRAPH YEAR MAIN NEBR IDMO;4
ADD YR2 WASH IN;4
BAR 3 3;4
BAR WIDTH 1;4
SYMBOL 1 4;SYMBOL 2 5;SYMBOL 4 3;4
LINE 2 1;LINE 4 1;4
LEGEND 1 "Main";ILEGEND 2 "Nebraska";ILEGEND 3 "Idaho";ILEGEND 4 &
"Washington";4
LEGEND 25 90;4
DR "Data for Years 1968, 1970, 1975, 1977";4
TI "PERSONAL INCOME PER CAPITA";4
XTIT "From STATISTICAL ABSTRACT OF THE UNITED STATES";4
YTIT "Dollars";4
XTIC 1955 5;4
XR 1955 1980;4
VR 1500 7500;4
Total of 22 lines in RUN file "PERSINCOME".
Listing Complete
You may now enter any Easy Graphing command, or press any User Key.
```

Fig. 2. A listing of the Easy Graphing Command File "PERSINCOME." Compare the command order to that in Fig. 1.

## How to Use Command Files

Now, let's turn our attention to a Command File created specifically to update the data for a weekly graph, display the past data as well as the new data, and save the updated data so the process may be repeated the following week.

First, let's assume we are the operator, the one who is updating the graph, and we don't know (or care) how it was created or even how the 4050 System works. We'll simply turn on the equipment, insert the Easy Graphing disc and tape, and press AUTO LOAD. Once Easy Graphing is loaded we know we are to type in RUN WEEKLY, then just answer the questions—four in this case.

```
Operator types in: RUN WEEKLY
4050 prompts: Enter this week number (1-52),
then press RETURN
Operator responds: 12
Second prompt: Enter amount of time spent on NSF projects,
then press RETURN.
Response: 12
Third prompt: Enter amount of time spent on NASA projects,
then press RETURN.
Response: 25
Fourth prompt: Enter amount of time spent on project control,
then press RETURN
Response: 3
```

The graph is updated and immediately displayed on the screen.

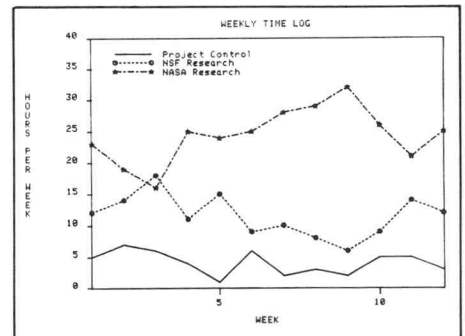

Fig. 3. Command Files allow you to design a graph but turn it over to others for updating. An operator had to respond to only four prompts to produce this updated graph.

As the operator, we had to know only a few steps: how to turn on the 4050 system and its peripherals, how to insert the disc and tape, and how to use the 4050 keyboard; all very simple.

## How a Command File Works

Now, using the UTILITIES LISTING routine, we'll take a look into the Command

<sup>1</sup>Because Command Files are executed by the Easy Graphing command RUN, they are also known as RUN files.

<sup>2</sup>Easy Graphing has eight UTILITIES routines which allow you to manipulate files.

File that accomplished this update—actually two Command Files are involved. The Command File WEEKLY contains the commands that drive the data update and display the graph. It calls another Command File, WEEKLYDATA, which handles the historical data input.

```

Page 1 of WEEKLY                                01-AUG-88 10:36:59 AM

RUN WEEKLYDATA
PRINT "Enter this week number (1-52), then press RETURN"
CHANGE WEEK 999.5 KEYBOARD
PRINT "Enter amount of time spent on NSF projects, then press RETURN."
CHANGE NSF 999.5 KEYBOARD
PRINT "Enter amount of time spent on NASA projects, then press RETURN."
CHANGE NASA 999.5 KEYBOARD
PRINT "Enter amount of time spent on project control, then press RETURN"
CHANGE CNTL 999.5 KEYBOARD
SAVE WEEKLYDATA
GRAPH WEEK CNTL NSF NASA, "WEEKLY TIME LOG", "WEEK", "HOURS PER WEEK";
LEGEND 1 "Project Control"; LEGEND 2 "NSF Research"; LEGEND 3 &
"NASA Research"; LEGEND 25 8914
YRANGE 0 40;XTIC 5;SYMBOL 2 5; SYMBOL 3 4

Total of 14 lines in RUN file "WEEKLY".
Listing Complete
You may now enter any Easy Graphing command, or press any User Key.

```

Fig. 4. The first of two Command Files used to produce the graph in Fig. 3.

```

Page 1 of WEEKLYDATA                            01-AUG-88 10:11:59 AM

ENTER WEEK 1 2 3 4 5 6 7 8 9 10 11
ENTER NSF 12 14 18 11 15 9 10 8 6 9 14
ENTER NASA 23 19 16 25 24 25 28 29 32 26 21
ENTER CNTL 5 7 6 4 1 6 2 3 2 5 3 1

Total of 4 lines in RUN file "WEEKLYDATA".
Press RETURN to continue...

```

Fig. 5. The second Command File above is called by first, i.e., 'RUN WEEKLYDATA' in Fig. 4.

Let's follow the execution of these Command Files. When the operator types in RUN WEEKLY, Easy Graphing locates the Command File WEEKLY on the disc, opens it and executes the first command which is. RUN WEEKLYDATA.

Easy Graphing locates WEEKLYDATA on the disc, opens it<sup>3</sup> and executes the commands. These commands ENTER the stored variables and data into Easy Graphing's memory.

Once these ENTER commands are executed, Easy Graphing closes the WEEKLYDATA file and returns to the next command within the still-open WEEKLY file—a PRINT statement.

Easy Graphing PRINTS the message on the screen and continues to the third command: CHANGE. When it sees CHANGE, it looks for the variable to change (WEEK), the location of the change<sup>4</sup>, and the data. When it sees KEYBOARD in the data position, it stops and waits for input from the keyboard. When it receives the input it's expecting (a CHANGE command requires numeric data as a parameter), it executes the CHANGE

<sup>3</sup>Up to 7 files may be open at one time.

<sup>4</sup>The arbitrary number of 999.5 ensures (in this case) that the data will be added after the last data position.

command (here by inserting the new data at the end of the data list for WEEK).

After all four variables have been updated (CHANGED), the command SAVE WEEKLYDATA is issued. When Easy Graphing executes a SAVE command, it saves all graphing parameters in its memory. The items in its memory at this point are the variables and the original data resulting from the ENTER commands, and the data added by the CHANGE commands. Thus, the updated data is now in the new WEEKLYDATA command file on disc (remember that a file on the disc with the same name as that in a SAVE command will be overwritten) (see Fig. 6.).

```

Page 1 of WEEKLYDATA                            01-AUG-88 10:38:56 AM

ENTER WEEK 1 2 3 4 5 6 7 8 9 10 11 12;
ENTER NSF 12 14 18 11 15 9 10 8 6 9 14 12;
ENTER NASA 23 19 16 25 24 25 28 29 32 26 21 25;
ENTER CNTL 5 7 6 4 1 6 2 3 2 5 3 1;

Total of 4 lines in RUN file "WEEKLYDATA".
Listing Complete
You may now enter any Easy Graphing command, or press any User Key.

```

Fig. 6. Notice the additional data in WEEKLYDATA above compared to that in Fig. 5.

The next commands in WEEKLY graph the X-axis (WEEK) and the three curves (CNTL, NSF, NASA), title the axes, add legends for each of the curves, set the Y-axis range and X-axis tic intervals and add symbols to the lines. Notice the default line styles are used.

Thus, the periodic report is easily done. You set it up once, and Easy Graphing and the Command Files handle all the details of the update. The person running the program has only been required to respond to a few questions about this week's data.

### Special Commands

The following are some special Easy Graphing commands which may be used in Command Files (in addition to the other Easy Graphing commands):

- BELL
- CONTINUE
- KEYBOARD
- PAUSE
- PRINT
- RUN
- SAVE

BELL causes the bell of the 4050 Series Graphic System to ring; a useful prompt in a Command File.

CONTINUE is used in conjunction with the PAUSE command.

KEYBOARD stops a command file and allows information to come from the 4050 keyboard. As soon as RETURN is pressed, it continues executing the Command File.

PAUSE stops a Command File until a CONTINUE is entered. PAUSE is similar to KEYBOARD in that it allows information to come from the 4050 keyboard. It is used instead of KEYBOARD when it is anticipated that one line of keyboard input will not be sufficient. The Command File remains suspended with information coming from the keyboard until CONTINUE is typed.

PRINT, just like the BASIC PRINT command, prints a message on the 4050 Screen.

RUN tells Easy Graphing to get a Command File from the disc and begin executing it.

SAVE instructs Easy Graphing to save all graph parameters in its memory on disc.

As you can see from the previous example in Fig. 4, KEYBOARD (as well as RUN, PAUSE and CONTINUE) may be embedded within another command. In this way the user's input, or the contents of another file, may be inserted into the command stream.

### How to Create a Command File

You create a Command File using the UTILITIES EDIT routine. To invoke the routine, type in UTILITIES EDIT. Easy Graphing responds with the EDIT command menu, which shows the commands at your disposal to create a Command File, and then prompts you for the name of the RUN (Command) File.

```

EASY GRAPHING "EDIT" UTILITY

COMMAND MENU
L - List to bottom of file          D - Go to top of file
C - Change text in current line    O - Delete current line
N - Print this command menu        Y - Save edited file or bail out
RETURN - Go to next line           I - Input after current line; null
                                   line to terminate

NOTE: An arrow (→) is printed to indicate the continuation of a long
line of text.
Enter RUN file name (RETURN to exit):

```

At this point, using the EDIT commands you may enter into the file any Easy Graphing commands and their parameters.

This completes the overview of PLOT 50 Easy Graphing. The first article described the components which aid you in using its command language:

- o EASY GRAPH Resource
- o TUTORIAL Resource
- o HELP Resource
- o User-Definable Key Syntax Resource
- o LIST Resource

The second article delved into its command language, familiarizing you with its capabilities. And in this article we looked at the Command Files. If you would like more information, or if you would like to see Easy Graphing in action, contact your local Tektronix Sales Engineer. 

# PROGRAMMING TIPS

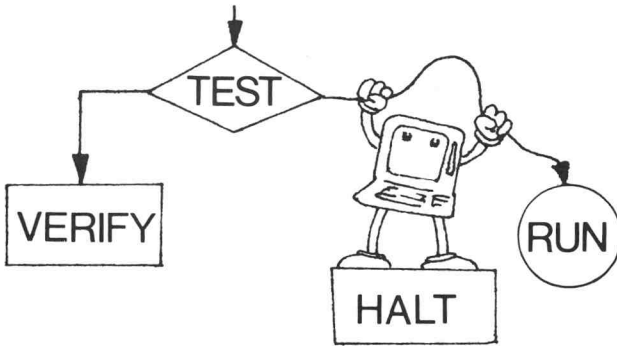

## Relocating a Subroutine

by Dan Taylor  
Tektronix, Inc.  
Wilsonville, OR

In the course of programming, often you'll want to relocate a subroutine. The following steps provide a method to move a subroutine around lines of code while maintaining the integrity of the statements referencing the subroutine.

1. REnumber your program to make room for the new location of the subroutine, if necessary.
2. SAve all.
3. DELEte all **except** the subroutine from 4050 memory.
4. REnumber the subroutine—carefully—to the desired location.
5. SAve the subroutine in another file.
6. OLD all of the original file (SAVED in Step 2).
7. DELEte the subroutine portion of the original statements.
8. Insert REMark statement at the beginning line number for the new subroutine location.
9. APPEND the subroutine to this REMark statement—don't specify an increment in the APPend statement.
10. Use the EDITOR in the PLOT 50 UTILITIES package or the EDITOR ROM Pack to fix the GOSUB's to the relocated subroutine, or do it manually.

Note. All GOTO, GOSUB, etc., statements **within** the subroutine to lines out of it or to lines within it are okay.

```

100 GOSUB 200
110 GO TO 300
200 PRINT USING 210:
210 IMAGE "Example of Moving Subroutine"
220 RETURN
300 REM
310 GOSUB 200
320 REM CONTINUE PROGRAM

Step 2 FIND 3
SAVE
  
```

Fig. 1. The subroutines contained in Statements 200 – 220 will be moved around the rest of the program to line numbers 1000 and above. In this case Step 1, REnumbering, isn't required. Save the original program.

```

Step 3 DEL 1,199
Step 4 DEL 300,65535
REN 1000

LIS
1000 PRINT USING 1010:
1010 IMAGE "Example of Moving Subroutine"
1020 RETURN

Step 5 FIND 4
SAVE
  
```

Fig. 2. Next delete all code before and after the subroutine to be moved. The listing illustrates that the REnumber in Step 4 also changed the line number reference in Statement 1000, i.e., from 210 (in Fig. 1) to 1010. Now save the REnumbered subroutine in another file.

```

Step 6 FIND 3
OLD

Step 7 DEL 200,299

LIS
100 GOSUB 200
110 GO TO 300
300 REM
310 GOSUB 200
320 REM CONTINUE PROGRAM
  
```

Fig. 3. OLD in the original program. DELEte the subroutine. The listing verifies that the subroutine is gone.

```

Step 8 1000 REM
Step 9 FIND 4
APPEND 1000
  
```

Fig. 4. Key in a REMark statement numbered with the beginning location of the subroutine and APPend the saved and renumbered subroutines.

```

Step 10: LIS
Change 100 GOSUB 200
110 GO TO 300
300 REM
Change 310 GOSUB 200
320 REM CONTINUE PROGRAM
1000 PRINT USING 1010:
1010 IMAGE "Example of Moving Subroutine"
1020 RETURN
  
```

Fig. 5. Now the GOSUB's, GOTO's, etc., referencing the relocated subroutine may be changed. Although this may be done manually, it's safer to use the EDITOR ROM Pack or the EDITOR program.

# Reconstructing a Header

by **Herman D'Hondt**  
Tektronix Australia Pty. Ltd.  
Sydney, Australia

and **David Walters**  
Tektronix, Inc.  
Orlando, FL

Anyone who has used the "non-header" tape mode (PRI@33,0:0,0,1) may at some time or another overwrite a file header with data or destroy it in some other manner. Consequently, this file won't be accessible in normal header mode, nor will you be able to do a TLIS of this file or any following. However, it is possible to reconstruct the file header so it is accessible again in header mode.

When the header is reconstructed, the program or data in the file may be accessed in the normal manner. However, if you have written data into the header itself and want to save it all, be sure to bring the data back into memory in non-header mode and transfer it to another tape. Reconstructing the header will overwrite the first 256 bytes of data.

The following routine prompts you for the information required to reconstruct your header. It is critical that you know how long your file was. If the new header specifies the file too long, you could overwrite the next

file when outputting a program or data. If the new header specifies the file too short, you won't be able to recover all your program or data. 

```
100 REM *** RECONSTRUCT HEADER FILE ***
110 INIT
120 PRINT "L"
130 FIND 0
140 PRINT @33,0:0,0,1
150 DIM Q$(1)
160 DIM A$(44)
170 A$="SEG("
180 REM *** C$ APPENDS REQUIRED CR AND DC3 TO HEADER ***
190 C$=CHR(13)
200 S$=CHR(19)
210 C#=C#&S$
220 A$=A#&C$
230 PRINT "WHICH FILE HAS THE DAMAGED HEADER? "I
240 INPUT F
250 F$=STR(F)
260 A$=REP(F$,1,LEN(F$))
270 PRINT "HOW LARGE WAS YOUR FILE MARKED (IE 1024, 5120, ETC.)? "I
280 INPUT L
290 L1=L/256
300 IF INT(L1)=L1 THEN 320
310 L1=INT(L1)+1
320 L$=STR(L1)
330 A$=REP(L$,36,LEN(L$))
340 PRINT "WAS YOUR FILE ASCII, BINARY, NEW OR LAST (A,B,N,L)? "I
350 INPUT T$
360 T=POS("ABNL",T$,1)
370 GOSUB T OF 440,460,480,500
380 IF T=2,5 THEN 570
390 PRINT "IS THE FILE PROGRAM, DATA OR TEXT (P,D,T) ?"I
400 INPUT P$
410 P=POS("PDT",P$,1)
420 GOSUB P OF 520,540,560
430 GO TO 570
440 A$=REP("ASCII",9,LEN("ASCII"))
450 RETURN
460 A$=REP("BINARY",17,LEN("BINARY"))
470 RETURN
480 A$=REP("NEW",9,LEN("NEW"))
490 RETURN
500 A$=REP("LAST",9,LEN("LAST"))
510 RETURN
520 A$=REP("PROGRAM",17,LEN("PROGRAM"))
530 RETURN
540 A$=REP("DATA",17,LEN("DATA"))
550 RETURN
560 A$=REP("TEXT",17,LEN("TEXT"))
570 PRINT "The File Header you have constructed is: ".A$
580 PRINT "(Your File Size is number of records * 256 or "L1*256:")
590 PRINT "Is this correct ?"I
600 INPUT Q$
610 IF Q$(1) THEN 100
620 FIND F
630 PRINT @33:A$
640 CLOSE
650 FIND 0
660 PRINT @33,0:0,0,0
665 TLIS
670 END
```

# BASIC BITS

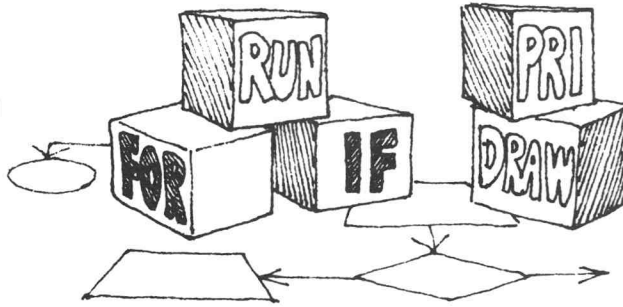

## Chaining GPIB Cables

by Patricia Kelley  
TEKniques Staff

Rather than connecting each of your GPIB peripheral cables to your 4050 Desktop Computer, resulting in a big stack of GPIB cables on the back of your 4050, you may chain them. For example, you can plug the GPIB cable from your 4907 into your 4050 GPIB port. Then to add a 4662 Plotter, simply plug it into the back of the GPIB cable in your 4907 port. Add a 4924 Tape Drive by plugging it into the GPIB cable of your 4662, and so on up to 15 peripherals. Any one cable, however, should not be longer than 20 meters. And, of course, for any GPIB interfacing, over one-half of the GPIB devices must be turned on for the system to operate correctly.

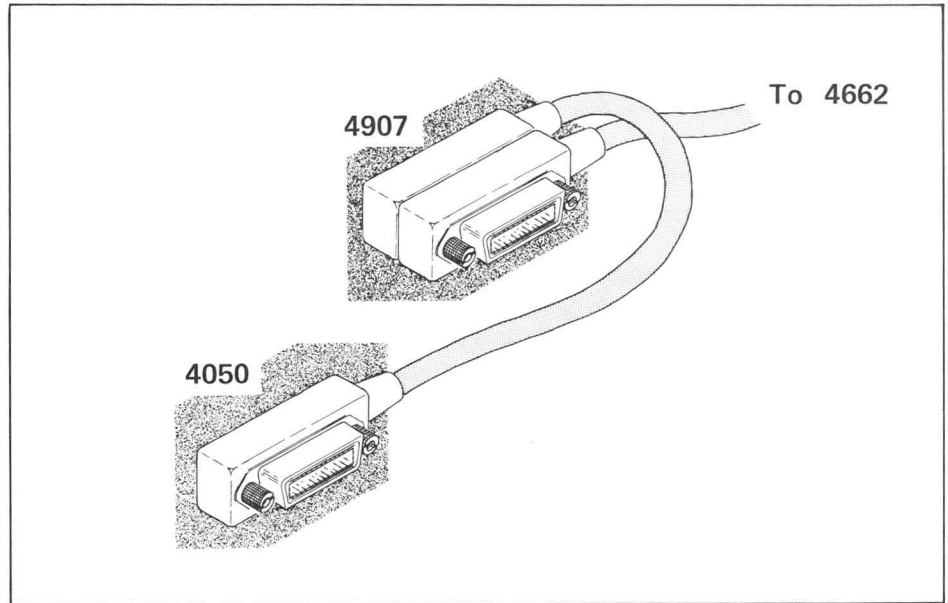

## Programming Tip Exchange

*Send in your programming tip. Any one of the following 4050 Series Applications Library programs\* will be yours when it's published. Simply jot down a brief description of the function, the code, and your choice of program. Mail it to the 4050 Series Applications Library serving you; Library addresses are listed at the back of each TEKniques issue.*

51/00-0501/0	51/00-6002/0
51/00-0901/0	51/00-8004/0
51/00-1403/0	51/00-8017/0
51/00-1603/0	51/00-8022/0
51/00-4002/0	51/00-9507/0
51/00-5204/0	51/00-9533/0

\*Documentation and listing only.



## 4050 Series Applications Library Program Abstracts

### Order

Documentation and program listings of each program are available for a nominal charge. Programs will be put on tape or disc for a small recording fee per program plus the charge for the tape cartridge or flexible disc. One tape/disc will hold several programs. Programs will be recorded on like media only, i.e., programs on tape cannot be sent on disc and vice versa unless so noted in the abstract.

(The program material contained herein is supplied without warranty or representation of any kind. Tektronix, Inc. assumes no responsibility and shall have no liability, consequential or otherwise, of any kind arising from the use of this program material or any part thereof.)

### Domestic U.S. Prices:

Documentation and listings	\$20 per program
Recording Fee	5 per program
Tape Cartridge	30 per tape
Flexible Disc	15 per disc

### Contribute

Contribute one program to the Library and receive three in exchange. Send in the membership card from your 4050 Series Graphic System Reference Manual to get the details. Or call us (503) 682-3411, ext. 3618.

### Forms

Please use the Applications Library Order Form. Order forms are included in the Membership Packet and are available from your local Tektronix Sales Engineer.

### Outside U.S.

Program contributions or orders outside the U.S. must be processed through the local Tektronix sales office or sent to one of the Libraries serving your area. See Library Addresses section.



### ABSTRACT #: 51/00-5205/0

Title: **On-Line Spectral Analysis (OLSA)**

Authors: R.J. Peterson,  
D.L. Raschella  
J.R. Uchida  
Dept. of Chemistry  
University of Tennessee  
Knoxville, TN

Memory Requirement: 32K

Peripherals: DVM  
Transera 641  
4662 Plotter

Statements: 1327

Files: 5 ASCII Program  
Requires a data tape

The program acquires spectrophotometric data from a digital voltmeter on a real-time basis. The data are recorded on magnetic tape and are subsequently analyzed and plotted. The resulting spectra may be displayed in several formats on either the 4050 Screen or the 4662 Plotter. Absorbance is plotted versus wave number and wave length. Scale expansions and spectrum flattening routines are provided.

The program is divided into four segments: input, baseline fit, plotting and display/edit routines. At the end of each segment, the operator can initiate the overlaying of the next segment or branching to another segment through the User-Definable Keys.

**Editor's Note:** See the article in this issue detailing the application, "4051 Aids in Study of Radioactive Elements".



### ABSTRACT #: 51/00-6113/0

Title: **Controlling FFT Operations from Tape**

Authors: L.D. Mitchell  
John H. Herold  
Donatus C. Ohanehi  
Mechanical Engineering Dept.  
Virginia Polytech. Inst.  
& State University  
Blacksburg, VA

Memory Requirements: 8K

Peripherals: Zonic Technical Laboratories  
FFT System Model 5003  
Option 1 Data Communications Interface

Statements: 147  
Files: 4 ASCII Program  
2 ASCII Data (examples)

These programs enable the user to automate FFT operations using the ZTL 5003 FFT machine. They also simulate the batch routine option available on ZTL's FFT.

Repetitive FFT operations may be controlled from tape. One program prompts the user to input FFT commands, delays to allow viewing, copying and transmitting of next commands and screen paging. These are stored in user-specified pre-marked data files.

A second program transmits FFT commands on tape to the FFT system, displays the commands and plots.

A third program loads FFT batch programs from 4050 tape into the FFT memory then allows interaction for editing or execution.

Theory, method and examples are all included in the documentation.



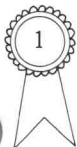

**ABSTRACT #: 51/00-6118/0**

Title: **20ma Current Loop Interface**

Authors: William M. Retallack  
John H. Taylor  
NOAA  
Boulder, CO

Memory Requirement: 8K  
Peripherals: Model 33 Teletype  
Statements: 52  
Files: 1 ASCII Program

One of the many different tasks we have in

data reduction is digitizing analog data and outputting long lists of X and Y values. To save on the cost of hard copy paper, a special interface was constructed. The analog data is digitized, scaled and the output is listed on a Model 33 Teletype. It has been in use for over three years and hasn't dropped a bit yet.

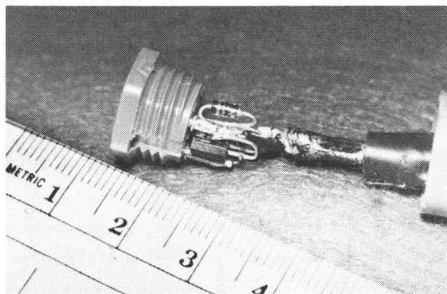

The interface connects through the RS-232 plug. Complete schematics are included in the documentation along with a short digitizer and output program.

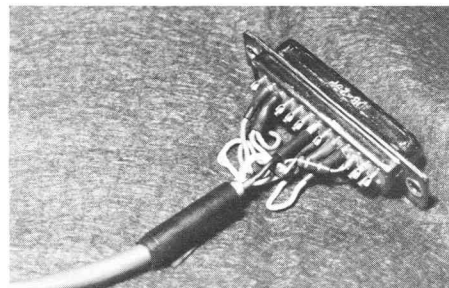

**ABSTRACT #: 51/00-5206/0**

Title: **On-Line Calorimetry Data Acquisition and Analysis (DCAL)**

Authors: J.R. Peterson  
D.L. Raschella  
J.R. Uchida  
Dept. of Chemistry  
University of Tennessee  
Knoxville, TN

Memory Requirement: 32K  
Peripherals: Digital Voltmeter  
Hewlett-Packard 3495A  
Transera 651  
4924 Tape Drive  
4662 Plotter

Statements: 1485  
Files: 6 ASCII Program  
Requires Data Tape  
(First 6 on tape or recode statements)

The program acquires calorimetric data from a digital voltmeter and an HP 3495A Scanner on a real-time basis. Using a thermistor in the microcalorimeter, the changes in temperature are detected as changes in resistance. A Wheatstone bridge is used to measure this resistance change. The change of resistance is monitored by the bridge detector. The output of the bridge detector and the voltages  $E_1$  and  $E_2$  are input to the 3495A Scanner. The 4051 commands the scanner to connect the appropriate channel. It then directs the DVM to read the voltage and send it to the 4051, where it's stored on tape. The program operates on an interrupt action by depressing appropriate User-Definable Keys. Reading rates may be altered. Experimental data that are collected consist of bridge calibrations, calibration heatings, and the dissolution reaction heat of the sample.

The data analysis/evaluation routine performs drift line extrapolations and all integrations; the results are stored on magnetic tape.



*Dr. D.L. Raschella operates the 4051 and microcalorimeter systems.*



**ABSTRACT #: 51/00-5902/0**

Title: **LORAN-C Receiver Interface to 4050**

Author: Peter G. Mauro  
Dept. of Transportation  
Cambridge, MA

Memory Requirement: 8K  
Peripherals: Northstar LORAN-C Model 6000 Receiver  
Northstar Interface Adaptor 6700  
Option 1 Data Communications Interface

Statements: 93  
Files: 1 ASCII Program

The program accepts serial information from a LORAN-C receiver and stores it on tape. It will plot the latitude and longitude position of the LORAN-C receiver on the 4050 Screen as both are driven along a roadway. It will plot directly from the receiver or from the data stored on tape.

It doesn't plot the latitude and longitude position directly but takes a running average of five consecutive readings to smooth out the plotted curve.

Areas of application include emergency vehicle dispatch and fishing craft path plotting.

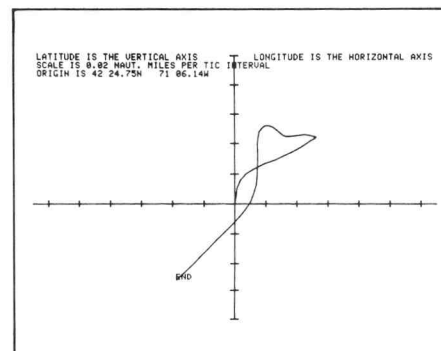



**ABSTRACT #: 51/00-6115/0**

Title: **Camera Triggering Circuit**

Authors: Steven Fahnenstiel  
William Retallack  
NOAA  
Boulder, CO

Memory Requirement: Determined by user program

Peripherals: User-built interface  
16-mm Camera

Statements: 14

Documentation Only

Animation has allowed us to show motions of particle populations in the earth's magnetosphere as a function of time, and provided a way to correlate data from two nearby satellites into a two-dimensional picture of boundary motion.

A surplus 16-mm single-frame camera with a 25-mm Angenieux lens is used for filming. The camera has a solenoid-operated guillotine shutter in which shutter speeds are determined by the duration of the applied current. The specially designed interface uses the signal lines from the GPIB. In 16-mm

format, plus-x reversal film at ASA 50 allows resolution limited only by that of the graphic system.

The camera is tripod mounted and roughly centered before the screen. Using a PRINT @32,21:65,50 statement, a reference point is drawn at the screen's center. Fine adjustment is done using a jig consisting of a square rod with two orthogonal vanes at its end. The camera is then positioned so that the vanes lie flush against the screen surface, with the rod aligned along the camera axis and centered on the screen. Camera-to-screen distance is 22 inches using f5.6 with a shutter speed of 1.5 sec.

A subroutine triggers the shutter one or more times in succession, followed by eight PAGE commands to reinitialize the automatic origin position.

Documentation includes interface schematics.

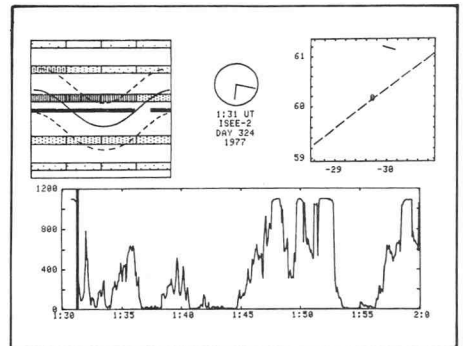
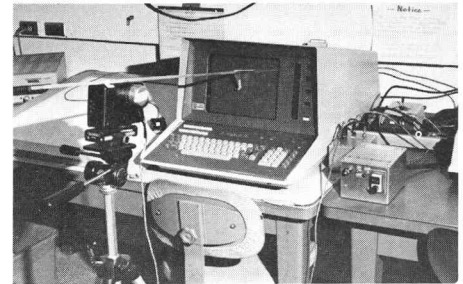
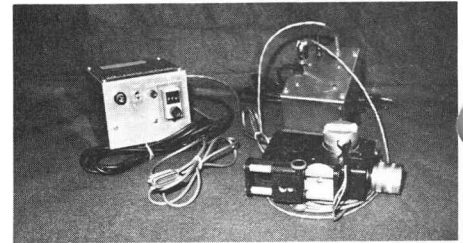

**ABSTRACT #: 51/07-5407/0**

Title: **Measurement of Absorption Spectra**

Author: John Rolfe  
National Research Council  
Ottawa Canada

Memory Requirement: 16K

Peripherals: 4907 File Manager  
GPIB Digital Voltmeter  
Hewlett-Packard 6940B  
Multiprogrammer  
300 Baud Printer  
Optical Apparatus

Statements: 349

Files: 1 Binary Program  
Requires Data Files

The apparatus controlled by this program measures optical transmittance of a sample as a function of wavelength. Wavelength is varied by a stepping motor on a monochromator. An analog circuit with a voltage output of 0 to +10 volts monitors the transmittance.

The program controls the stepping motor through HP 6940B with a 59500A GPIB Interface unit. The digital voltmeter used to read transmittance is a Systron-Donner 7344A. Program slews stepping motor to starting wavelength, scans through to ending wavelength in steps separated by time intervals. Step size and time intervals are calculated by the program for optimum information collection based on the monochromator band width (calculated from the slit width) and the time constant of the analog circuit.

The data is printed in tabular form, plotted on the 4050 screen and recorded on the 4907 disc as the run progresses. The main data file is random access binary, each record containing the transmittance. The wavelength is easily calculated from the record number since readings are taken at equal wavelength intervals. At the end of the experiment all parameters are written on a separate header file, a short sequential file which is useful for subsequent data processing.

User-Definable Keys allow for interruption or stopping the run, manual stepping of the monochromator, and some housekeeping functions.

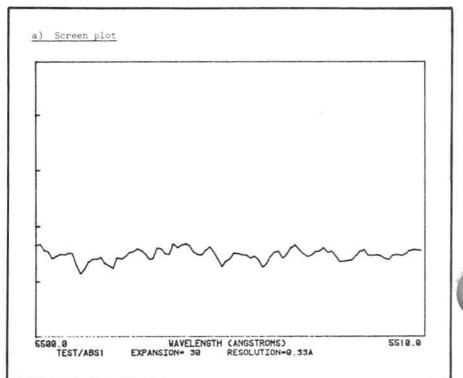
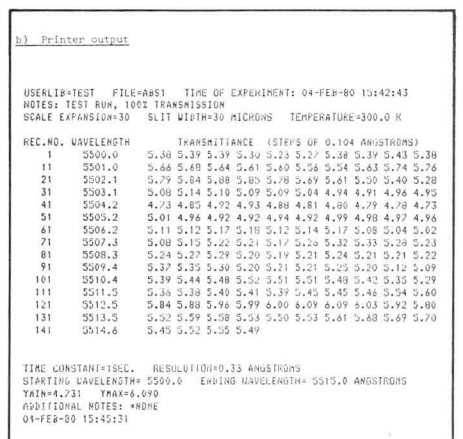



**ABSTRACT #: 51/00-6119/0**

**Title: 4050-ARGUS Display Subsystem Interface**

Author: Chuck Paulsen  
E.I. DuPont  
Newtown, CT

Memory Requirement: 8K  
Peripherals: Option 1 Data Communications Interface  
IEE-ARGUS Alphanumeric Display Subsystem (Plasma Dot Matrix)

Statements: 124  
Files: 5 ASCII Program  
1 Binary Data (example)  
Requires pre-marked data files

We use the 4051 to drive our ARGUS display. The first program prompts for the "pages" of 8-line messages to display and the time delay between messages. It converts the messages into the special six-bit code required by the display device, and stores the messages and display time on tape.

A second program reads the information from the data file and outputs one page at a time to the display.

File 1 is a directory. Files 2 and 3 contain the programs which have no REMark statements in order to conserve on memory. Files 4 and 5 contain the programs documented with REMark statements.

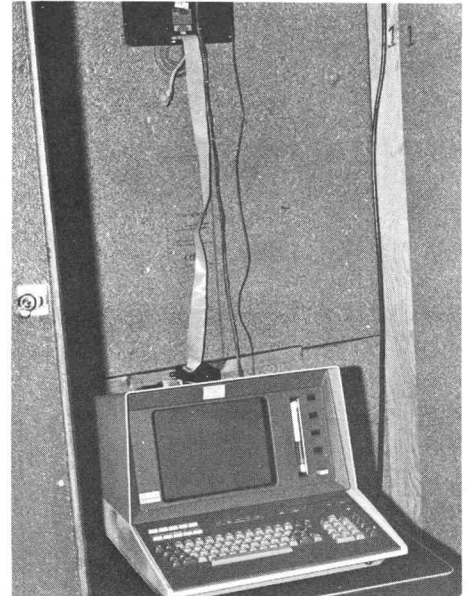
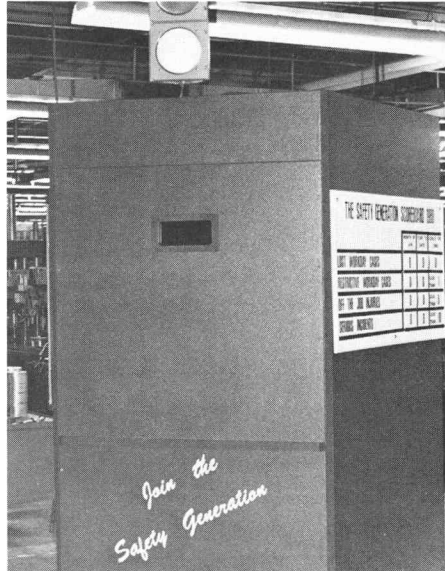

**ABSTRACT #: 51/00-6116/0**

Title: **A/D Sampling and Modification**  
Author: Barry T. Bates  
Dept. of Physical Education  
University of Oregon  
Eugene, OR

Memory Requirement: 24K, 32K best  
Peripherals: 4051R05 Binary ROM Pack  
Transera 652-ADC A/D Converter ROM Pack

Statements: 412  
Files: 1 ASCII Autoload  
1 Binary Program

Sixteen data channels can be monitored over three different voltage ranges of  $\pm 10$ , 2.4 and 0.3 volts with resolutions of 5, 1.2, and .16 millivolts. Single channel sampling rates of 38,819 and 23,496 samples/sec are possible with 8 bit and 12 bit mode respectively. Multi-channel sampling rates are limited to 9000 samples/sec.

The ROM Pack A/D provides 12 routines for operating, manipulating and displaying the data. In addition to controlling the ROM Pack routines through the User-Definable

Keys, the control program provides an additional five functions.

Initialize program

- Bit resolution
- Voltage Range
- Number of Channels
- Sampling order
- Sampling rate
- Sample total

Sampling

- Keyboard
- Automatic triggering
- Designate channel
- Input voltage
- Pre-trigger values

- Unpack data (string to array—floating point)
- Unpack 2 data (string to array—raw voltages)
- Pack data (array to string)
- Modify/scale data
- Graph data
- Print data
- Summarize/change parameters
- Data to tape
- Data from tape
- Delete data points



**ABSTRACT #: 51/00-8033/0**

Title: **Digitize and Modify Data**

Author: Barry T. Bates  
Dept. of Physical Education  
University of Oregon  
Eugene, OR

Memory Requirement: 16K  
Peripherals: 4051R05 Binary ROM Pack  
Digitizer using GPIB

Statements: 505  
Files: 1 ASCII Autoload  
1 Binary Program  
Data Files Required

The program inputs data from a digitizer and writes it to tape. Data may be stored in two forms: a) Two files per data point digitized, first file: I\$,N,T1,X1,T2,X2, ...; second file: I\$,N,T1,Y1,T2,Y2; or b) Single file: I\$,N,P,X1, Y1,X2,Y2 ...Xn,Yn,T1,T2, ...Tn; where T values are absolute time of occurrence or image number input as integer values and X and Y are the coordinates of the data points. Choice A is convenient if data are to be smoothed.

The user indicates the number of data points to be digitized per frame/image and the total number of frames/images is determined by memory. The data for each frame/image may be digitized once or several times and averaged for storage. In addition the user can input a reference point as the last data point

and all values can be shifted so they are identified relative to this point. This references all framed/images to a common coordinate system without reorientation of the coordinate system with each new frame/image. Program is terminated by a time or counter value greater than 99. The data may be corrected during or following digitizing. User-Definable Keys scale, shift, print and graph the data.

Parts of the program may be overlaid to increase memory for data.



**ABSTRACT #: 51/00-6117/0**

Title: **Tektronix/Hewlett-Packard 488 Interface**

Author: Robert Cope  
Michael Bowman  
Atlantic Analysis Corp.  
Norfolk, VA

Memory Requirement: 8K  
Peripherals: Hewlett-Packard 9835 or 9845  
Statements: 70  
Files: 1 ASCII Program

This program transfers messages input from the keyboard of an HP 9835 to a TEKTRONIX 4051 and vice versa. The purpose is to demonstrate the capability of the HP 9835 and TEKTRONIX 4051 to communicate using the standard IEEE-488 Interface bus and to demonstrate the interrupt capabilities and limitations of both computers. The configuration simulates an interconnection between a TEKTRONIX 4054 and a Hewlett-Packard 9845 which were not available at the time the evaluation was conducted.

Communications using the 488 bus will make it possible to off load the graphics processing load in ECLIPS tactical display systems to an intelligent graphics display

which will free the other computer for message processing and textual information display. The interrupt capabilities of the machines will make it possible for each processor to devote full time to their respective tasks, being interrupted only to service operation requests or intercomputer communications needs on a time available basis ensuring that the high priority message processing is never neglected.

The complete evaluation is included as part of the documentation.



**ABSTRACT #: 51/00-6120/0**

Title: **Hewlett-Packard-Tektronix-Amdahl Interface**

Author: Subarna B. Malakar  
Dept. of Natural Resources  
State of Florida  
Gainesville, FL

Memory Requirement: 8K  
Peripherals: Option 1 Data Communications Interface  
Hewlett-Packard 9810A programmable calculator  
Hewlett-Packard 11205A Interface  
Amdahl 470 V/6-II with OS/MVS Release 3.8 and JES2 NJE Release 3 of NERDC, U. of Fla.

Statements: 241  
Files: 5 ASCII Program  
1 ASCII Data (example)

The programs perform the following functions.

1. Directory.
2. TCP-SIGN ON—Allows 4051 to operate as a terminal to the host computer at 1200 baud. It prompts the user to sign-on to the host computer on TCP mode, and to execute select TCP commands by returning to BASIC.
3. TCP to TEK—Allows a TCP file from the host computer to be sent to a tape file on the 4051.
4. TEK TAPE to TCP—Allows data on 4051 tape to be sent to TCP **workfile**.
5. HP to TEK TAPE—Allows data from HP 9810A system cassette files to be

transferred and stored in 4051 tape files. External switching is required to change the interface to HP 9810A. Certain prompting control characters must be sent from HP 9810A through the PARAMETER LIST key for other conditions.



**ABSTRACT #: 51/00-5702/0**

Title: **Two Factor Repeated Measures and Independent ANOVA**

Author: Barry T. Bates  
Dept. of Physical Education  
University of Oregon  
Eugene, OR

Memory Requirement: 16K  
Peripherals: 4051R05 Binary ROM Pack  
Transera Auxiliary Memory  
Manager

Statements: 744  
Files: 1 ASCII Auto Load  
8 Binary Program  
Requires Pre-marked Data Files

This statistical package analyzes two factor repeated measure designs (AxBxS). Data may be input from the keyboard or from tape, and stored on tape. In addition to the

summary table, the marginal means of each of the three matrices can be evaluated as well as any of the simple main effects. A final feature collapses the data into a two-factor independent measures design (AxB) or simply analyzes two-factor independent measures data. All main effects and simple main effects can be evaluated.

The program is separated into eight sections. Although the sections are stored in the Auxiliary Memory Module, they could be called from tape or disc. User-Definable Keys drive the program:

- Data from keyboard
- Data from tape
- Data to tape
- Compute
- Matrix Computations

- Summary Table (R)
- Matrix Analysis (R)
- Simple Main Effects (R)
- Main Effects (I)
- Summary Table (I)
- Simple Main Effects (I)



3. INTERNAL DATA STORAGE	
a.	
Simple Variables	Used to Store . . .
S	Number of subjects
C	Levels of one factor (conditions)
T	Levels of other factor (trials)
N,K1	Counters
NI	S = T
CS, C9, R8, R9	Variables used to identify different degrees of freedom
SS, S9, T8, T9	F-ratio and file number for tape
F	Variables used to calculate partial values for F-ratio
X1, X2, X3, X4	Variables used to identify means for comparisons
Y1, Y2, Y3, Y4	
Z1, Z2, Z3, Z4	Temporary variables for S, C, T
W1, W2	Temporary variables for "M", "C", "M"
P, Q, R	Title of tape file
PS, OS, RS	Temporary string variables
IS	
CS, ZS	
Array Variables	Used to Store . . .
A(N1+1, C+1)	Raw data plus row and column sums
A1(3)	Sum of squares for C, S, T
A2(3)	Sum of Squares for CS, CT, ST
A4(1)	Sum of squared scores
B2(5)	Sums of scores for S factors
B3(7)	Sums of scores for T factors
A1, C+1	Sums of scores for C factors
C1(C*8)	Sums of scores for CS factors
C2(C*7)	Sums of scores for CT factors
A(N1+1, I)	Sums of scores for ST factors
S1(3)	Sums of squared scores divided by number of scores for C, S, T
S2(3)	Sum of squared scores divided by number of scores for CS, CT, ST
S3(1)	Sum of squared scores divided by number of scores for CST
S4(1)	Sum of squared scores
M(S)	Mean squares
M1(S+1, C+1)	Data plus row and column sums for SC matrix
M2(T+1, C+1)	Data plus row and column sums for TC matrix
M3(S+1, T+1)	Data plus row and column sums for ST matrix
M4(P+1, Q+1)	Temporary array for simple main effects analysis

## Other New Programs

The following programs are new with this issue of TEKniques. However, since they are described in the catalog which accompanies this issue, the complete abstract will not be presented here. They are categorized and the abstract number, the title, and the author are furnished to help you locate them in the catalog.

### Business

#### Accounting

**ABSTRACT #: 51/00-0104/0**

Title: **Project-Schedule Chart**

Author: Polly Jennings  
Tektronix, Inc.  
Beaverton, OR

#### Analysis

**ABSTRACT #: 51/00-0720/0**

Title: **Machinery Cost Analysis**

Author: Gene Laurel  
Ministry of Agriculture & Food  
Vineland Station, Ontario,  
CANADA

### Engineering

#### Civil

**ABSTRACT #: 51/00-1203/0**

Title: **PLAIMETER**

Author: Steve J. Czehura  
The Anaconda Copper Company  
Butte, MT

**ABSTRACT #: 51/0-1204/0**

Title: **Unit Traverse**

Author: U.S. Forest Service  
Six Rivers National Forest  
Eureka, CA

**ABSTRACT #: 51/00-1205/0**

Title: **Watershed Measurement**

Author: Gerald Zastera  
Nebraska Natural Resources  
Commission  
Lincoln, NE

### Scientific

#### Physics

**ABSTRACT #: 51/00-5408/0**

Title: **Simulation of the Millikan Oil**

zTitle: **Drop Experiment**

Author: D.D. Venable  
R. Blakey  
Hampton Institute  
Hampton, VA

### Mathematics

**ABSTRACT #: 51/00-5505/0**

Title: **Mixture Experiment & Contour**

Author: Connie Breithaupt  
Tektronix, Inc.  
Rockville, MD

**ABSTRACT #: 51/00-5506/0**

Title: **3-D Function Plot**

Author: Dony Robert  
Brussels, Belgium

### Miscellaneous

**ABSTRACT #: 51/00-6121/0**

Title: **Speak/Plot**

Author: Scott Adams  
State of Nevada  
Central Data Processing  
Carson City, NV

### Utility

**ABSTRACT #: 51/00-8012/1**

Title: **Leroy Character Generator**

Author: Mark Mehall  
Tektronix, Inc.  
Wilsonville, OR

**ABSTRACT #: 51/07-8034/0**

Title: **Variable Name Changer**

Author: Mallory M. Green  
U.S. Dept. of HUD  
Washington, D.C.

**ABSTRACT #: 51/00-8035/0**

Title: **REMark Outliner**

Author: Mallory M. Green  
U.S. Dept. of HUD  
Washington, D.C.

**ABSTRACT #: 51/00-8036/0**

Title: **Spider's Web Character Generator**

Author: Gene Lynch  
Tektronix, Inc.  
Wilsonville, OR

**ABSTRACT #: 51/00-8037/0**

Title: **Automatic Hardcopy File Listings**

Author: Roger Chan  
USV Pharmaceutical Corp.  
Tuckahoe, NY

**ABSTRACT #: 51/00-8038/0**

Title: **Text Editor**

Author: Dennis Ward  
Tektronix, Inc.  
Beaverton, OR

**ABSTRACT #: 51/00-8039/0**

Title: **Tape File Header Expander**

Author: Randy Bowling  
Tennessee Valley Authority  
Chattanooga, TN

**ABSTRACT #: 51/00-8040/0**

Title: **Variable Font Presentation Aid**

Author: William R. Sebra  
U.S. AMSAA  
Aberdeen Proving Ground, MD

**ABSTRACT #: 51/00-8041/0**

Title: **Binary Data File Duplicator**

Authors: R. Molins, Y. Juguet  
National Polytechnic Institute  
Grenoble, France

### Graphics

**ABSTRACT #: 51/07-9539/0**

Title: **Enhanced Pie Chart**

Author: Isaac C. Arthur, Jr.  
U.S. Dept. of HUD  
Washington, D.C.

**ABSTRACT #: 51/00-9540/0**

Title: **GAZINTAMAP**

Author: Gene Turner  
California State University  
Northridge, CA

**ABSTRACT #: 51/07-9541/0**

Title: **Negative/Positive Bargraph**

Author: Isaac C. Arthur, Jr.  
U.S. Dept. of HUD  
Washington, D.C.

**ABSTRACT #: 51/00-9542/0**

Title: **4010 Style Graphic Character  
Data to GDU Conversion Rewrite**

Author: Paul J. Kristof  
Tektronix, Inc.  
Wilsonville, OR



# 4050 Series Applications Libraries

## **Africa, Europe, Middle East**

Contact local sales office

## **Australia**

4050 Series Applications Library  
Tektronix Australia Pty. Limited  
Sydney  
80 Waterloo Road  
North Ryde, N.S.W. 2113

## **Canada**

4050 Series Applications Library  
Tektronix Canada Ltd.  
P.O. Box 6500  
Barrie, Ontario  
Canada L4M 4V3

## **Caribbean, Latin America and Far East (excl. Japan)**

IDD Group  
Export Marketing  
Tektronix, Inc.  
P.O. Box 500  
Beaverton, Oregon 97077  
U.S.A.

## **Japan**

4050 Series Applications Library  
Sony/Tektronix Corporation  
9-31 Kitashinagawa-5  
Tokyo 141 Japan

## **United States**

4050 Series Applications Library  
Tektronix, Inc.  
Group 451  
P.O. Box 500  
Beaverton, Oregon 97077

**Tektronix**<sup>®</sup>  
COMMITTED TO EXCELLENCE

**TEKTRONIX, INC.**  
**Information Display Division**  
**Applications Library**  
**Group 451**  
**P.O. Box 500**  
**Beaverton, Oregon 97077**

**ADDRESS CORRECTION REQUESTED**