

Oscilloscope Tube

D13-47..

GENERAL

This 5 inch diagonal rectangular tube with electrostatic focusing and deflection is designed for medium bandwidth applications and is capable of being deflected by transistor circuits. It incorporates a means of beam blanking at anode potential which avoids d.c. coupling to the grid.

Heater Voltage	V_h	6.3	V
Heater Current	I_h	0.3	A

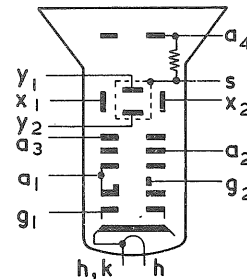

ABSOLUTE RATINGS

		Max	Min	
Fourth anode voltage	V_{a4}	7.0	2.5	kV
Third anode voltage	V_{a3}	1.75	0.6	kV
Second anode voltage	V_{a2}	1.0	0	kV
First anode voltage	V_{a1}	1.75	0.6	kV
Negative control grid voltage	$-V_{g1}$	200	1.0	V
Beam blanking voltage	V_{g2}	2.0	0.5	kV
Peak x plate to third anode voltage	$v_{x-a3(pk)}$	500	-	V
Peak y plate to third anode voltage	$v_{y-a3(pk)}$	500	-	V
x plate to third anode resistance	R_{x-a3}	5.0	-	$M\Omega$
y plate to third anode resistance	R_{y-a3}	100	-	$k\Omega$
Control grid to cathode resistance	R_{g1-k}	1.5	-	$M\Omega$
Second anode current	I_{a2}	10	-	μA
P.D.A. ratio (V_{a4}/V_{a3})		4:1		
Helix resistance		-	50	$M\Omega$

All voltages referred to cathode unless otherwise stated.

PHOSPHOR SCREEN

This type is usually supplied with GH phosphor (D13-47GH) giving a green trace of medium short persistence. Other phosphor screens can be made available to special order.

Thorn Radio Valves and Tubes Limited

Jan. 1970, Issue 3, Page 1

INTER - ELECTRODE CAPACITANCES

Grid to all	C_{g1-all}	10	pF
Grid 2 to all	C_{g2-all}	10	pF
Heater and cathode to all	$C_{h,k-all}$	4.0	pF
x ₁ plate to x ₂ plate	C_{x1-x2}	2.1	pF
y ₁ plate to y ₂ plate	C_{y1-y2}	1.6	pF
x ₁ plate to all, less x ₂ plate	$C_{x1-all, less x2}$	7.0	pF
x ₂ plate to all, less x ₁ plate	$C_{x2-all, less x1}$	6.7	pF
y ₁ plate to all, less y ₂ plate	$C_{y1-all, less y2}$	5.0	pF
y ₂ plate to all, less y ₁ plate	$C_{y2-all, less y1}$	5.0	pF
x ₁ , x ₂ plates to y ₁ , y ₂ plates	$C_{x1,x2-y1,y2}$	0.8	pF
Grid 1 to x ₁ , x ₂ , y ₁ , y ₂ plates	$C_{g1-x1,x2,y1,y2}$	1.3	pF
Grid 1 to Grid 2	C_{g1-g2}	0.6	pF

TYPICAL OPERATION - voltages with respect to cathode.

Fourth anode voltage	V_{a4}	3.0	4.0	6.0	kV
Mean deflector plate potential		750	1000	1500	V
Third anode voltage for optimum astigmatism correction	V_{a3}	750*	1000*	1500*	V
Second anode voltage for optimum focus	V_{a2}	125 to 300	175 to 400	260 to 600	V
First anode voltage	V_{a1}	750	1000	1500	V
Shield voltage for optimum raster shape	V_s	750*	1000*	1500*	V
Beam blanking voltage for cut-off	V_{g2}	700†	935†	1400†	V
Control grid voltage for cut-off	V_{g1}	-25 to -50	-35 to -65	-50 to -95	V
x deflection coefficient	D_x	10.5 to 13.2	14.5 to 17.5	21 to 26.2	V/cm
y deflection coefficient	D_y	5.0 to 6.2	6.7 to 8.3	10 to 12.5	V/cm
Minimum screen area		10 x 6	10 x 6	10 x 6	cm ²
Line width at centre] at 5 μ A beam current	0.5	0.45	0.4	mm
Line width at edge		0.9	0.8	0.8	mm

* The required voltage will not differ from the quoted value by more than $\pm 50V$.

† The beam is unblanked when $V_{g2} = V_{a1}$. This grid 2 electrode should not be used as a brilliance control.

RASTER DISTORTION AND ALIGNMENT

The total screen area is 10 cm x 6 cm measured about a point ± 3 mm from the centre of the tube face. The undeflected spot will fall in a circle of 6 mm radius about the centre of the tube face. The edges of a test raster will fall between two concentric rectangles 10 cm x 6 cm and 9.8 cm x 5.85 cm.

Rectangularity of x and y axes is $90^\circ \pm 1^\circ$. The horizontal trace will be parallel with the axis of the rectangular face-plate to within $\pm 5^\circ$. A twist coil will be required to effect accurate alignment. This should be mounted inside the magnetic shield approximately 90 mm from the face and should not extend more than 175 mm from the face. 24 ampere turns will suffice, with provision for reversing the current if necessary.

It is preferable that the mean x and y plate potentials are equal otherwise some deterioration in performance will occur. Under any circumstances the mean y plate potential should never differ from the mean x plate potential by more than 50V when the tube is operated at 4 kV.

MAGNETIC SHIELDING

Adequate magnetic shielding is required. In addition due attention should be paid to the position of the tube relative to transformers and chokes.

TUBE WEIGHT(approximate) - 960 g

MOUNTING POSITION unrestricted.

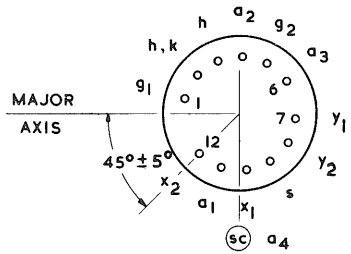
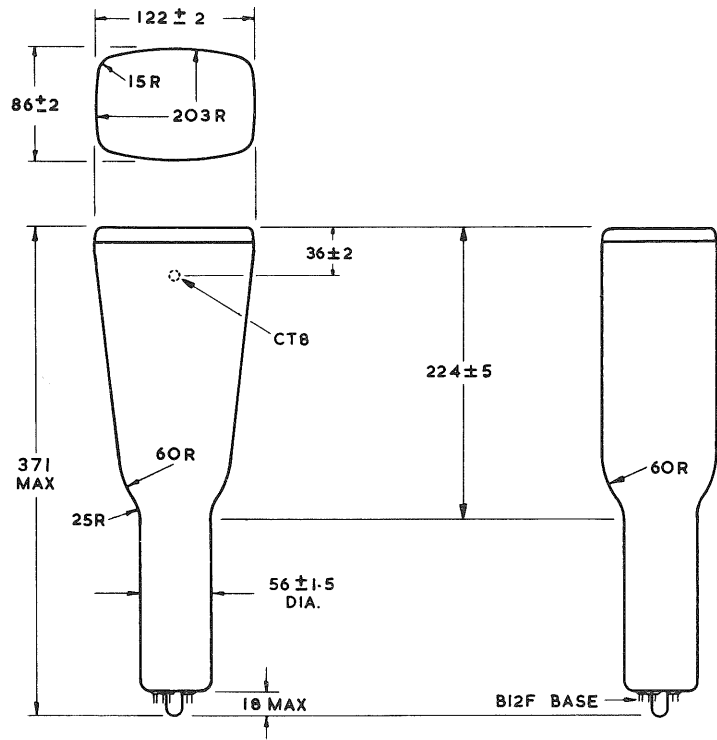

VIEW FROM PINS FREE END
(CT8 AT BOTTOM)

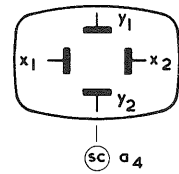

VIEWED FROM SCREEN END
(CT8 AT BOTTOM)

All dimensions in mm

Third angle projection

Not to be scaled

It is advisable to support the tube near the screen, and at a second point on the parallel neck near the base. The tube should not be subjected to any stress from the use of clamps and should not be suspended by the base. Connecting leads should not be soldered directly to the tube pins.

Oscilloscope Tube

D13-47..

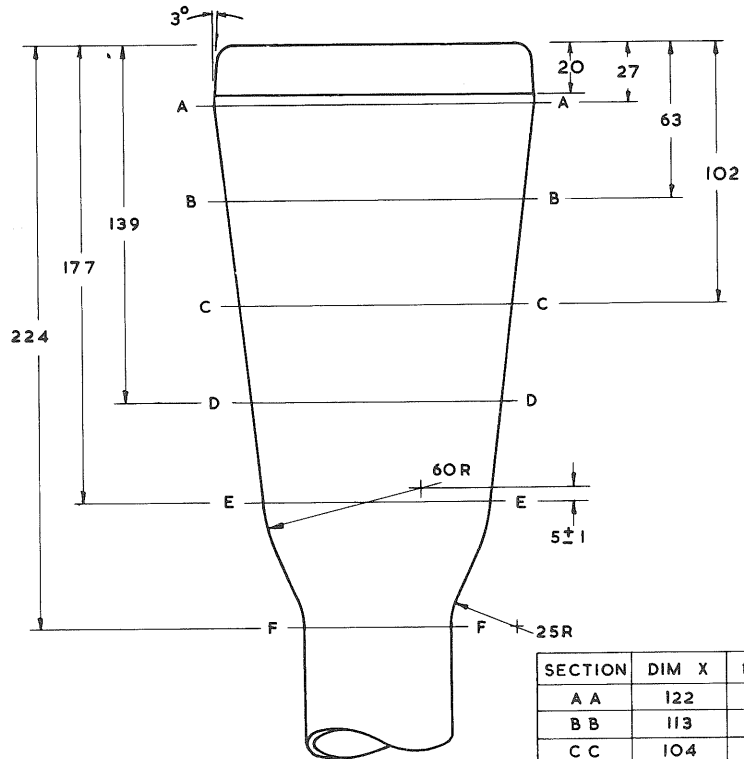
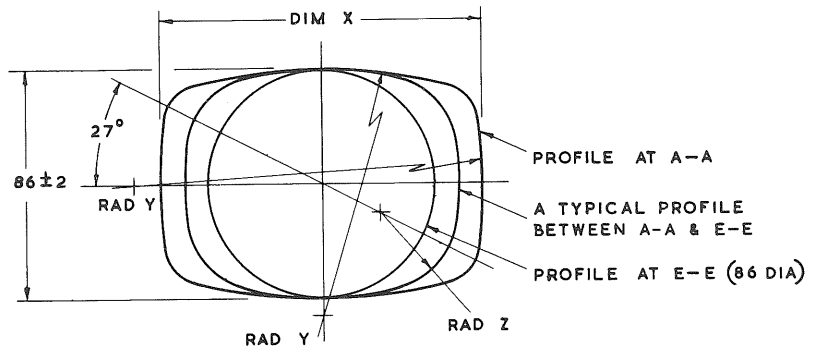

SECTION	DIM X	RAD Y	RAD Z
A A	122	203	15
B B	113	163	22
C C	104	123	29
D D	95	83	36
E E	86	43	43
F F	56	28	28

All dimensions in mm

Third angle projection

Not to be scaled

Jan. 1970, Issue 3, Page 5

Thorn Radio Valves and Tubes Limited

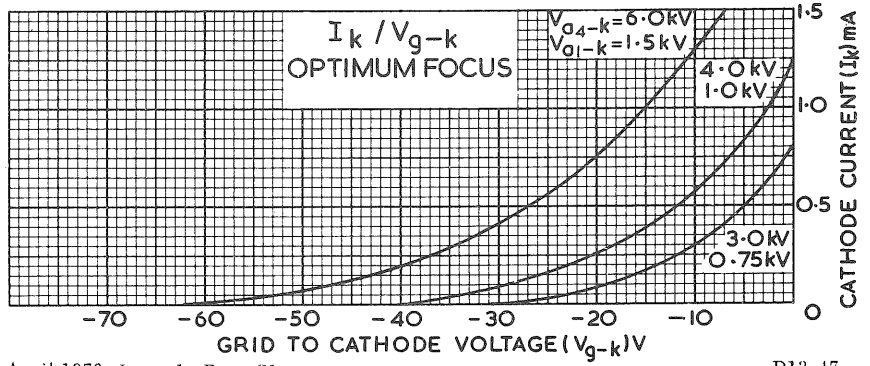
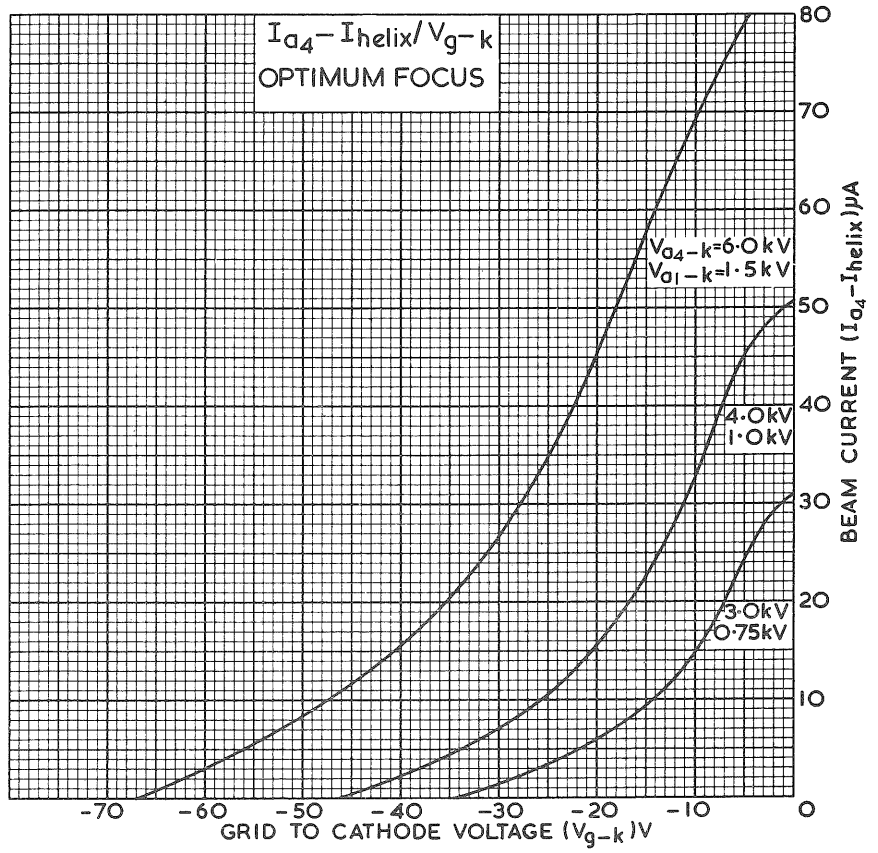

Magnetic Shield MS23

D13-47..

MATERIAL 0.65 Mumetal
4 LUGS 1.2 Mumetal spotwelded to shield
Each lug has M4 or 4BA hank
bushes fitted
METAL TOLERANCES ± 0.4
FINISH Silver hammer outside
Matt black inside
PADS Soft sponge neoprene
All dimensions in mm
Not to be scaled

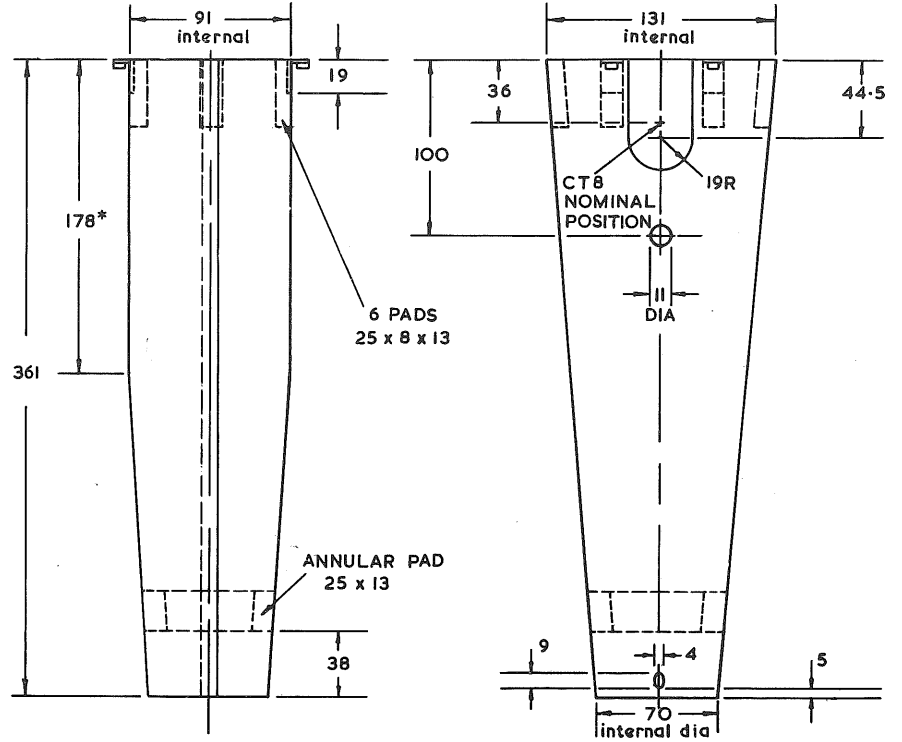
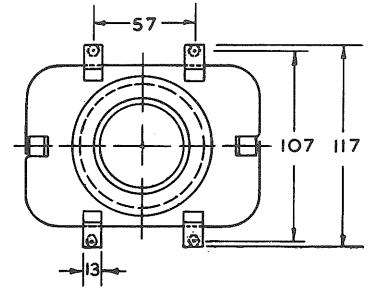

* Dimensions at this length are 92 outside x 102 outside with approx. 30R.

Thorn Radio Valves and Tubes Limited

Apr. 1972, Issue 1, Page E1





MANDREL FOR TWIST COIL TW30

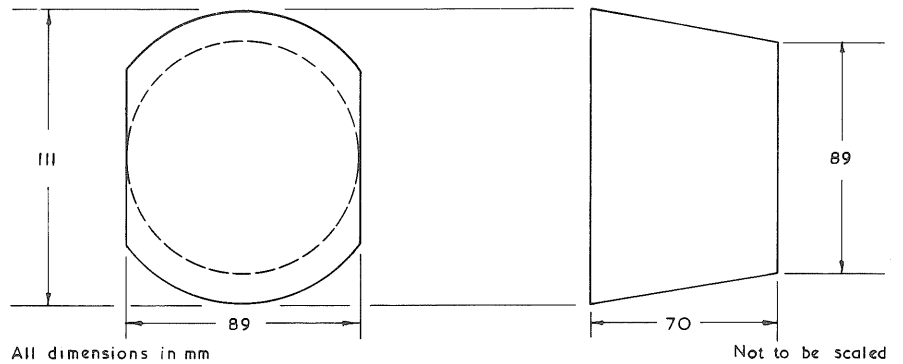

SHIELD

This twist coil is designed to be used in conjunction with magnetic shield MS23 for D13-47..

WINDING

1150 turns of 38 SWG Lewmex F at 290 turns per layer, wound on paper to give 10 mm margin between coil and mandrel at each edge of coil. Start and finish of winding to be brought out in 300 mm flexible lead wires from centre of long straight side of winding. Varnish and cover with paper to produce a stiff finished coil.

ELECTRICAL CHARACTERISTICS

Resistance approx. 330 Ω . Twist coil coefficient approx. 4.5 mA/degree measured on a typical D13-47.. with $V_{a1} = 1.5\text{kV}$ $V_{a4-k} = 6\text{kV}$.

FITTING

The completed twist coil should be pushed hard into the shield with the lead out wires coming out through the appropriate hole and secured in two places with suitable adhesive tape.

Thorn Radio Valves and Tubes Limited

Mar. 1972, Issue 1, Page F1



