

010-0260-00

WARRANTY

All TEKTRONIX instruments are warranted against defective materials and workmanship for one year. Any questions with respect to the warranty should be taken up with your TEKTRONIX Field Engineer or representative.

All requests for repair and replacement parts should be directed to the TEKTRONIX Field Office or representative in your area. This will assure you the fastest possible service. Please include the instrument Type Number or Part Number and Serial Number with all requests for parts or service.

Specifications and price change privileges reserved.

Copyright © 1973 by Tektronix, Inc., Beaverton, Oregon. Printed in the United States of America. All rights reserved. Contents of this publication may not be reproduced in any form without permission of Tektronix, Inc.

U.S.A. and Foreign TEKTRONIX products covered by U.S. and foreign patents and/or patents pending.

TEKTRONIX is a registered trademark of Tektronix, Inc.

TEKTRONIX®

P6058 PROBE

Manufactured After June 13, 1973

(Code Date 7324)

INSTRUCTION MANUAL

Tektronix, Inc.
P.O. Box 500
Beaverton, Oregon 97005

Serial Number _____

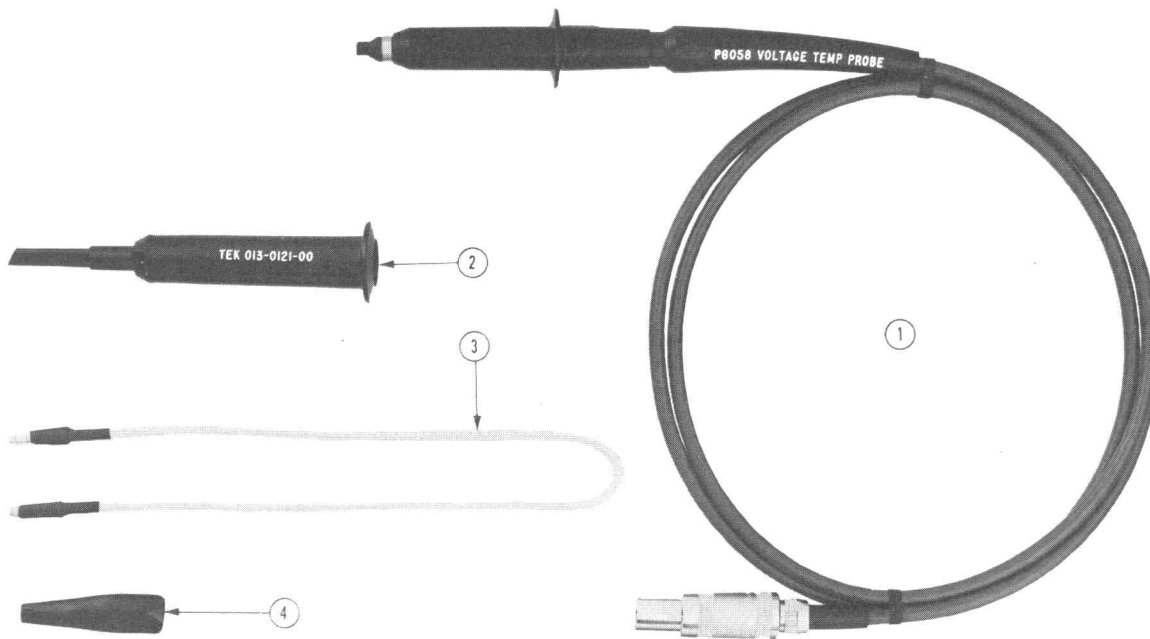

1112-10

Fig. 1-1. P6058 Probe with standard accessories

PROBE and ACCESSORIES

Fig. & Index No.	Tektronix Part No.	Serial/Model No. Eff	Dscnt	Qty	1 2 3 4 5	Name & Description	Mfr	
							Code	Mfr Part Number
1-1	010-0260-00 ¹			1		PROBE PACKAGE:P6058	80009	010-0260-00
	-----			-		. PROBE PACKAGE INCLUDES:		
-1	010-0259-00			1		. LEAD,TEST:P6058	80009	010-0259-00
STANDARD ACCESSORIES								
	020-0041-00 ¹			1		. ACESS,KIT,TEST:P6058	80009	020-0041-00
-2	013-0121-00			1		. . TIP,PROBE:	80009	013-0121-00
-3	175-0991-00			1		. . LEAD,ELECTRICAL:12 INCHES LONG	80009	175-0991-00
-4	344-0046-00			1		. . CLIP,ELECTRICAL:ALLIGATOR TYPE,W/COVER	80009	344-0046-00

¹Not included with DM501.

SECTION 1

P6058 SPECIFICATION

General Information

The P6058 Probe is a combination 1X DC voltage and temperature measuring device. It is designed for use with TEKTRONIX Digital Multimeter Plug-In Units having readout.

The temperature and voltage sensor element consists of a transistor installed in a nose tip that plugs into the end of the probe body. For voltage measurements, a twelve inch "common" (low) strap is provided, which is attached by screwing it into a threaded hole in the side of the probe body. There is no external ground on the P6058 body; ground, or the low potential point of the circuit under test, is obtained via the common strap or connector which is a floating common that has no connection to chassis ground.

This lead may be floated to a potential of 40 VDC away from chassis ground.

A pincher tip allows fixed attachment of the probe tip to the high potential point of the circuit where voltage measurements are being taken.

Actual chassis ground connection from the digital multimeter is supplied through the probe connector shell and connects to the sensor transistor base element through the two shields for the wires to the emitter and collector leads; however, this chassis ground is not externally accessible at the probe body.

Temperature is measured by applying the P6058 sensor tip so that the flat surface of the tip mates against the device to be measured.

ELECTRICAL CHARACTERISTICS

Characteristic	Performance Requirement	Supplemental Information
DC Volts		
Range	Zero to 500 volts	
Accuracy	Refer to multimeter manual	
Maximum Input Voltage	500 V between high and common	40 V between common and chassis ground
Temperature Measurement ² (Equilibrium)		
P6058 Alone		
Range	-55°C to +150°C	Surface temperature measurement accuracy is affected by: (1) Angle of contact between probe tip and surface of device being measured; (2) Thermal Gradient, which approximately equals 6.2% of the difference between final surface temperature and ambient temperature, see Fig. 1-2; (3) Heat Sinking when small devices are being measured, see Fig. 1-3.
Accuracy ¹	Refer to multimeter manual	
Maximum Safe Voltage on Measurement Surfaces	To ±400 V (DC + peak AC) above chassis ground.	
Typical RF frequency and voltage limits on measurement surface	Refer to Fig. 1-5.	
Temperature (Storage and Operating)		
Probe Body and Cable	-55°C to +105°C	
Probe Sensor Tip	-55°C to +150°C	See Fig. 2-1 for identification

²Temperature measurement characteristics apply to the standard surface-measurement sensor tip supplied with the P6058.

ENVIRONMENTAL CHARACTERISTICS

Characteristic	Information
Altitude	
Storage	To 50,000 feet
Operating	To 15,000 feet
Humidity	
Storage and Operating	5 cycles (120 hours) to 95% relative humidity referenced to MIL-E-16400F (paragraph 4.5.9 through 4.5.9.5.1, Class 4).
Shock	
Nonoperating	To 400 g's, 1/2 sine, 1/2 ms, 1 ms, and 2 ms duration. (With retractable tip installed.)
Maximum force at which sensor tip may be applied to the surface being measured	20 pounds

PHYSICAL CHARACTERISTICS

Characteristic	Information
Dimensions	
Cable Length	46 inches including probe body
Net Weight	
Complete with Accessories	≈ 5 ounces
Shipping Weight	
Complete with Accessories	≈ 13 ounces

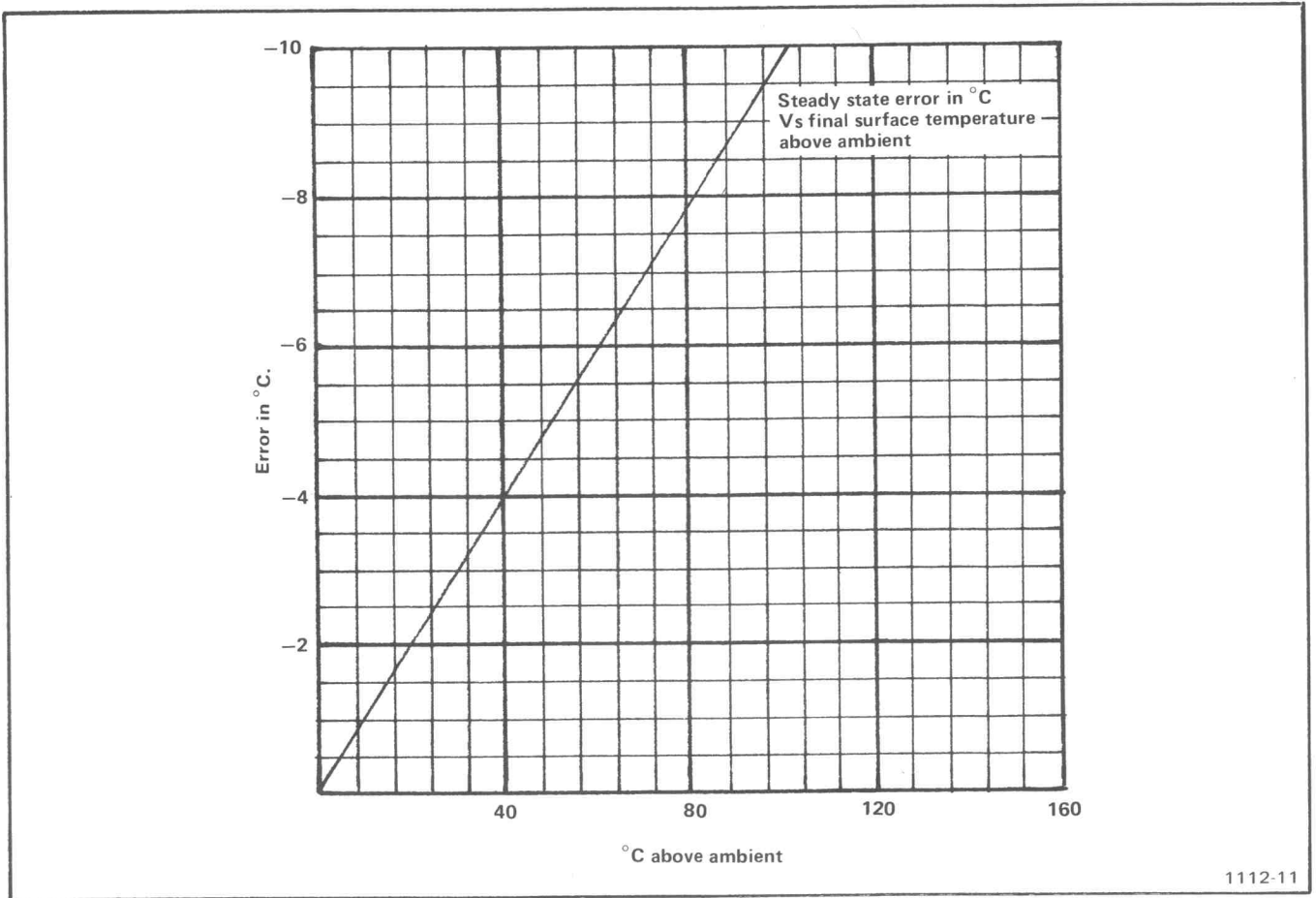

Fig. 1-2. Thermal gradient effect on temperature measurement. (Refer to page 2-2 for discussion of thermal gradient.)

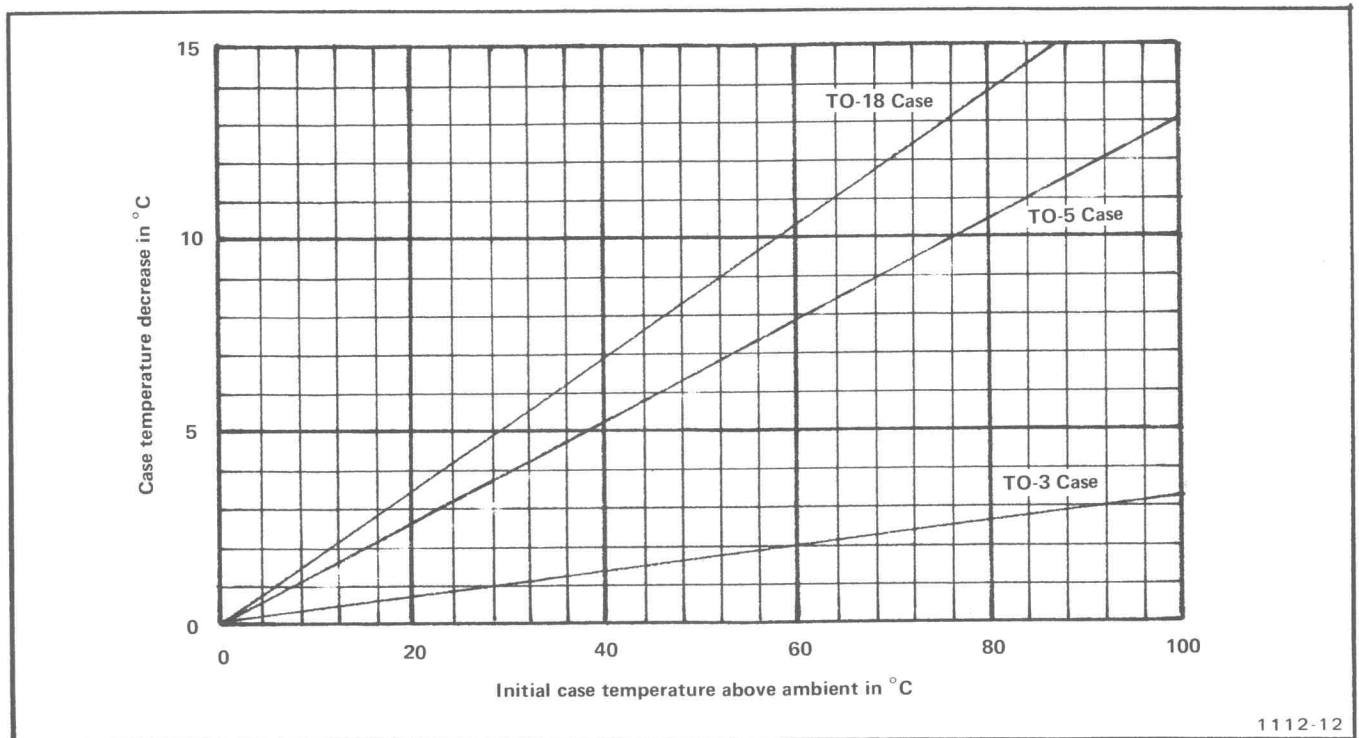
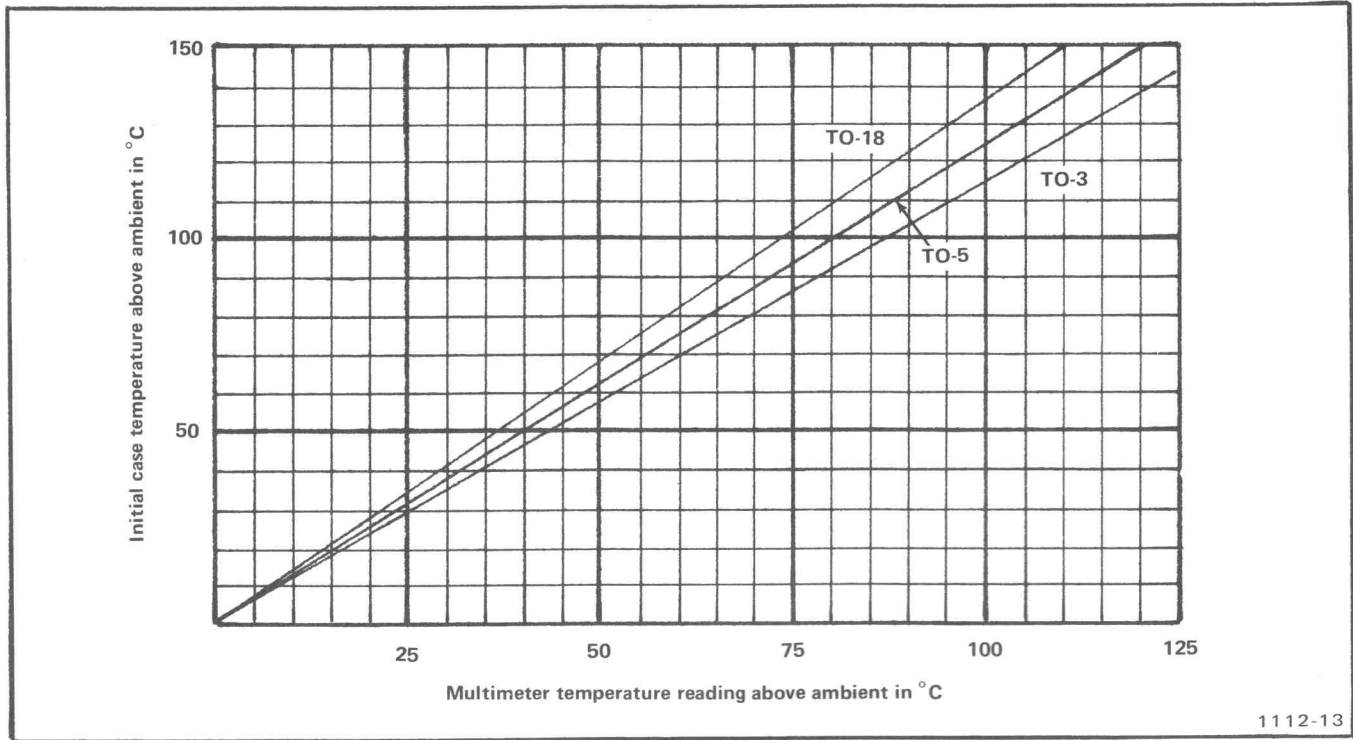
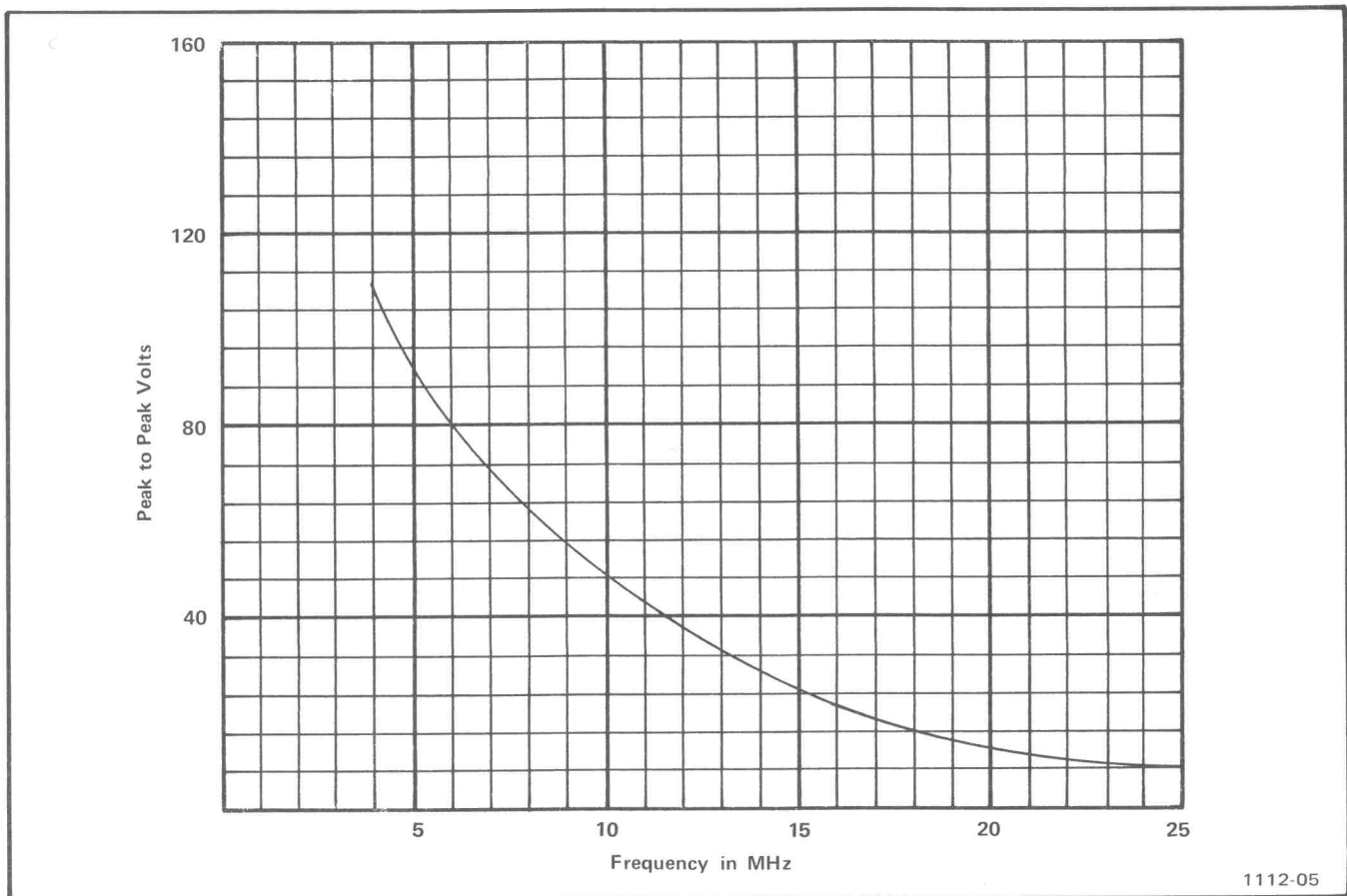

Fig. 1-3. Typical decrease in device case temperature in °C due to P6058 heat-sinking effect on various devices (with silicon thermal joint compound applied).



1112-13

Fig. 1-4. Typical initial case temperature above ambient vs multimeter reading above ambient. (Subtract ambient temperature from multimeter reading, then use graph to determine actual device case temperature above ambient.)



1112-05

Fig. 1-5. Typical allowable RF signal limits at the tip to maintain in tolerance temperature measurement.

SECTION 2

OPERATING INSTRUCTIONS

General Information

The P6058 probe provides voltage and temperature measurement when used with TEKTRONIX digital multimeters having readout. The plug-in feature of the nose tip sensor transistor allows easy replacement or interchanging with any future sensor elements of different configurations. No adjustments are required since the transistor is the only electrical component in the probe assembly. The small diameter probe body design lends itself to use in compact circuitry. Power is supplied to the transistor and signal is connected to the associated digital multimeter through a 4 conductor cable and special 4 pin plug. Ground for the base of the sensor transistor is applied through the shell of the probe plug. Fig. 2-1 and 2-3 show connections for the transistor and probe cable plug.

CAUTION

The sensor tip is fragile and may break if dropped or subjected to excessive mechanical stress. Force ex-

erted on the sensor tip should not exceed 20 pounds. The retractable hook tip will help protect the sensor tip if it is attached to the probe at all times when temperature is not actually being measured.

Theory of Operation

The convenience of providing DC voltage and temperature measurement within a single probe is accomplished through the use of a solid state NPN silicon transistor located at the tip of the voltage probe. Associated circuitry is located in the digital multimeter.

The emitter-base voltage of the transistor is the parameter which is measured to indicate temperature. With zero collector-base voltage and sufficient emitter-base voltage, the collector current of a transistor can be expressed as an exponential function of the base-emitter voltage:¹

$$I_C = I_0 \exp (qV_{be}/kT)$$

When the associated digital multimeter circuitry switches the collector current between two levels, the difference between the two levels of emitter-base voltage will be a linear function of temperature; i.e.

$$\Delta V_{be} = \frac{kT}{q} \ln (I_{C2}/I_{C1})$$

Where I_{C2} and I_{C1} are the two levels of collector current, k is Boltzmann's constant, q is the charge on the electron, and T is absolute temperature. The factors limiting the linear range of operation are the decrease in beta at low temperatures and leakage currents at high temperature. The sensor transistor is connected in the feedback loop of the operational amplifier with the collector at the input, emitter connected to the output, and the base grounded. For a given current input, the output of the operational amplifier forward biases the emitter-base junction of the transistor to the level necessary to maintain the input collector current. (Input current to the operational amplifier is negligible and thus the input current essentially is the collector current of the transistor.)

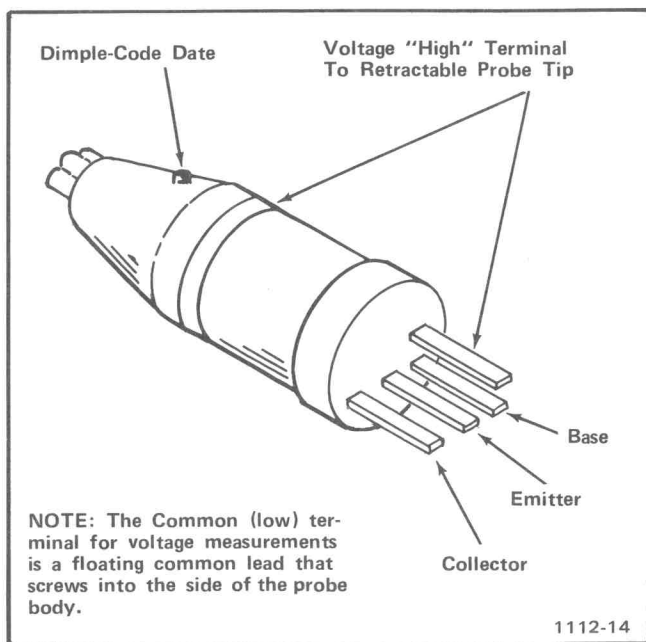

Fig. 2-1. Connections to sensor tip.

¹Electronic Devices and Circuits, Millman & Halkias, McGraw-Hill, 1967.

Use with TEKTRONIX Digital Multimeter Plug-Ins

When the front panel rotary switch is set to temperature, the temperature measurement is displayed in alpha-numeric form. When the front panel rotary switch is set to any of the four DC volts ranges adjacent to the temperature position, the voltage reading¹ taken by the P6058 will be displayed in alpha-numeric form. The temperature information is also available in analog form at the temp out front panel terminals when the front panel rotary switch is set to any position. This allows simultaneous monitoring of temperature along with current, resistance, or voltage, when an auxiliary recorder or meter is connected to the temp out terminals.

Connecting the P6058 to the Digital Multimeter

CAUTION

If the P6058 connector and the Digital Multimeter jack are not correctly aligned, the terminals can be damaged by forcing the connector and jack together. Be sure the flat surfaces of the insulated portions of the jack and connector are parallel before attempting to connect them together.

Measuring DC Voltage¹

Attach the retractable probe tip to the P6058 sensor tip for all voltage measurements. Electrical contact between the retractable tip and the sensor tip is made through the band on the sensor tip body. Connect the retractable tip to the high potential point of the circuit to be measured, and the common strap to the low potential point. Read the voltage from the readout.

WARNING

The P6058 is designed to measure voltages as high as 500 volts DC above chassis ground. Potential on the Low (common) input terminal may be elevated to 40 VDC above chassis ground. The voltage between the High and Low leads must not exceed 500 volts DC. To avoid dangerous shock, it is advisable to disconnect the power from the circuit being tested while either the High or Low leads are being connected or disconnected. After the power is activated to the circuit under test, avoid contact with any exposed metal on the P6058 body or connecting leads.

Measuring Temperature

CAUTION

The probe body, cable, and standard sensor tip should not be immersed in any liquid.

¹Refer to DM501 instruction manual for necessary instrument modifications to accomplish this.

The surface of the device to be measured should be coated with silicone grease, and the P6058 sensor tip applied to mate the flat surfaces of the tip and the device, (see Fig. 2-2) to assure optimum temperature transfer. Surface temperature reading is affected by the angle of contact between probe tip and the surface being measured. When taking a reading, this angle should be varied slightly until the maximum reading is obtained on the associated Digital multimeter. Temperature may be read as outlined under the preceding paragraph titled "Use with TEKTRONIX Digital Multimeter Plug-Ins".

Applying the tip of the P6058 to a device for temperature measurement may cause a slight change in the temperature of the device. This is similar to the voltage change in an electrical circuit caused by probe loading, and in the case of temperature measurement, is due to a combination of heat sinking and a steady-state gradient error associated with transfer of heat between bodies. Heat sinking depends on the thermal mass of the device being measured. The amount of heat sinking, in degrees C versus the initial device temperature above ambient, is illustrated in Fig. 1-3 for TO-3, TO-5, and TO-18 transistor cases.

In addition to heat sinking effect, there is a "steady state" error when measuring surface temperature which is caused by the "steady state" gradient associated with flow of heat from the device being measured to the main probe body. Thus the temperature of the sensing transistor will differ from the final surface temperature. This steady state error is dependent upon the final surface temperature above ambient and is illustrated in Fig. 1-2 in Section 1 of this manual.

In order to approximate the actual surface temperature of the device, that existed before the P6058 was applied, both the heat sinking and the thermal gradient effects must be considered. Fig. 1-4 provides a convenient method for approximating the combined heat sinking and thermal gradient errors for three common transistor cases, the TO-3, TO-5, and TO-18. The initial temperature of the case can also be found to within 5% using the following equations.

$$\text{TO-3: } T_I = 1.13 T_M - 0.13 T_O$$

$$\text{TO-5: } T_I = 1.25 T_M - 0.25 T_O$$

$$\text{TO-18: } T_I = 1.36 T_M - 0.36 T_O$$

T_I is the initial case temperature, T_M is the temperature read from the associated multimeter, and T_O is the ambient temperature.

Replacing the Probe Cable or Connector

Fig. 2-3 shows the color code of the cable wires, and an exploded view of the connector assembly, to aid in replacing these items should they become damaged or defective.

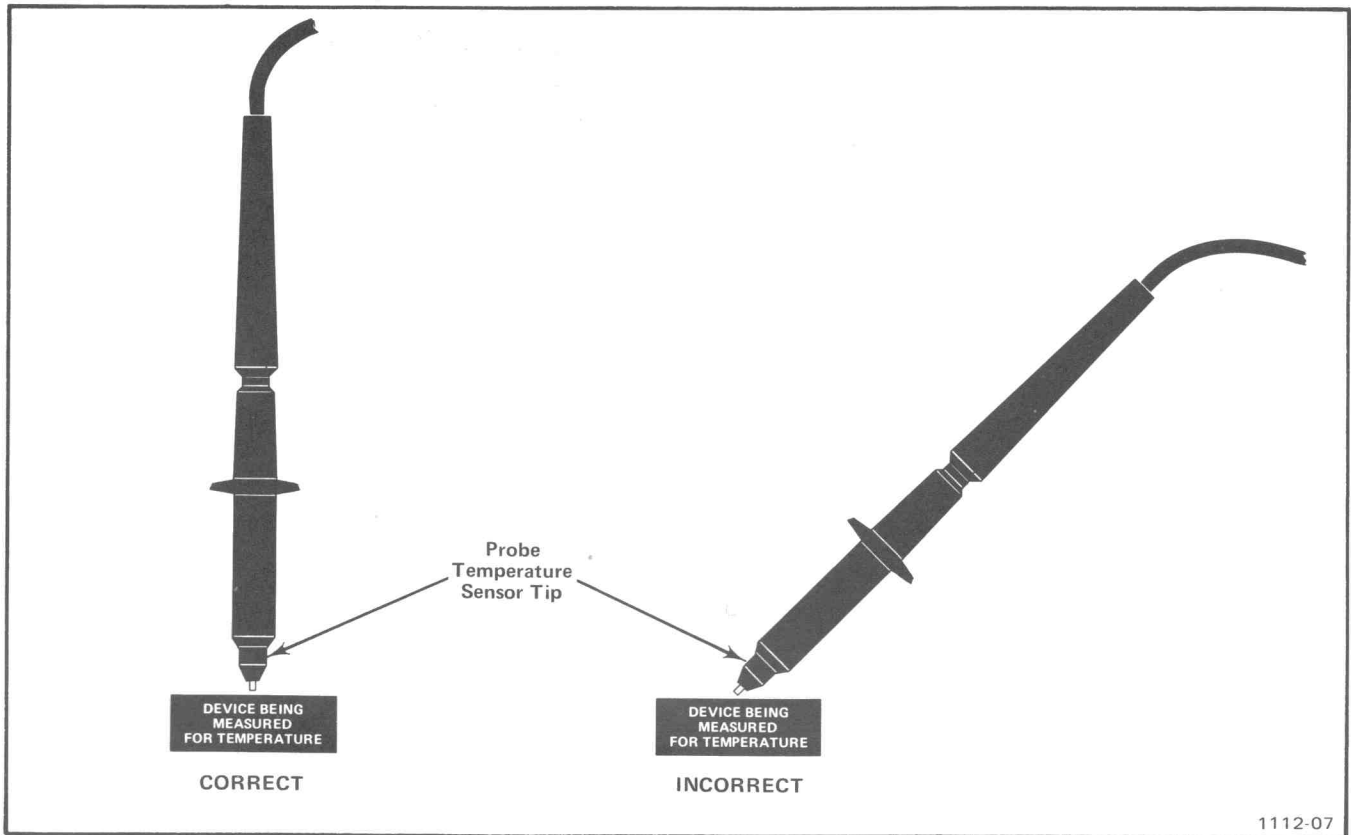

Fig. 2-2. Correct and incorrect method of applying sensor tip for temperature measurement.

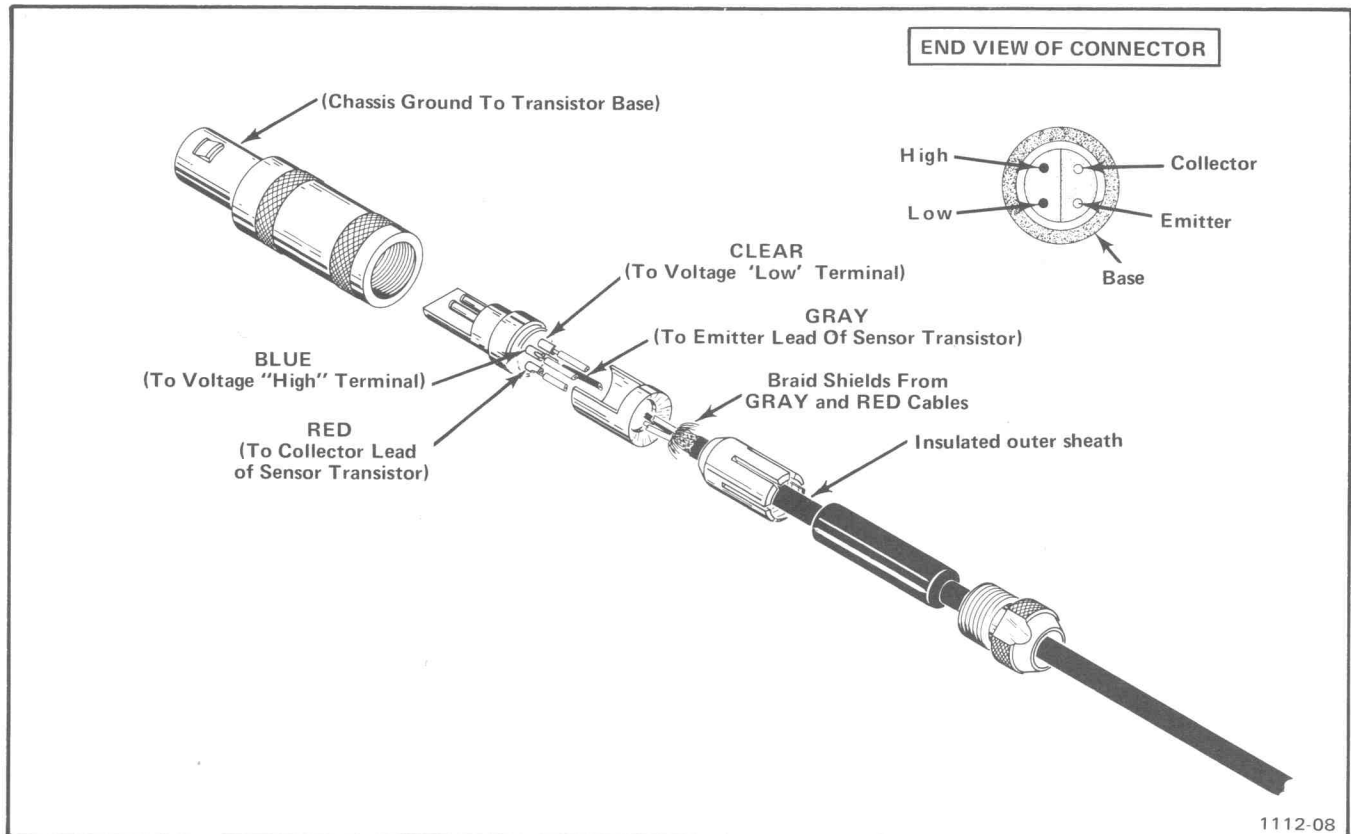
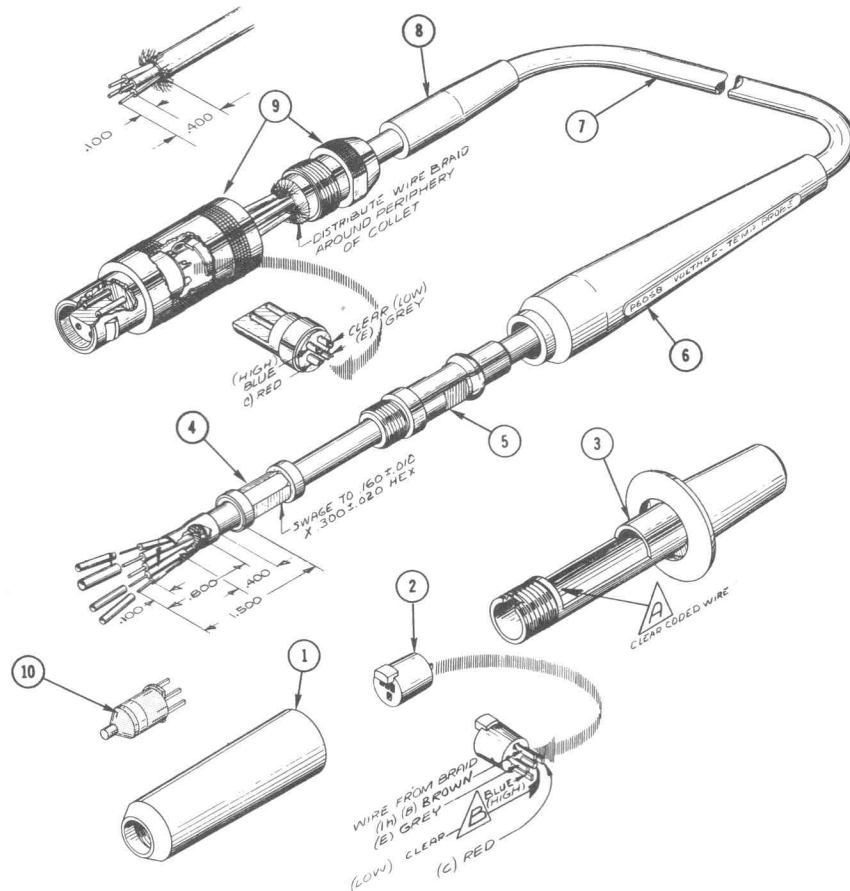

Fig. 2-3. Wiring color code and exploded view of P6058 connector and cable.

SECTION 3 PARTS LIST REPLACEABLE PARTS



1112-09

Fig. & Index No.	Tektronix Part No.	Serial/Model No. Eff	No. Dscont	Qty						Name & Description	Mfr Code	Mfr Part Number
					1	2	3	4	5			
	010-0259-00			1						PROBE, P6058	80009	010-0259-00
	175-1213-00			1						CABLE ASSY, RF:	80009	175-1213-00
-1	204-0457-00			1						BODY, SHL, PROBE:	80009	204-0457-00
-2	136-0427-00			1						SKT, PROBE TIP:	80009	136-0427-00
-3	204-0456-00			1						BODY SHL, PROBE:	80009	204-0456-00
	175-1212-00			1						CABLE ASSY, RF:	80009	175-1212-00
-4	343-0305-00			1						CLAMP, CABLE:	80009	343-0305-00
-5	103-0135-00			1						ADAPTER, CA TO P:	80009	103-0135-00
-6	200-1182-00			1						CABLE NIP, ELEC:	80009	200-1182-00
-7	175-1199-00			FT						CABLE, SP, ELEC: 3.667 FT LONG	80009	175-1199-00
-8	200-1192-00			1						COV, STRAIN RLF:	80009	200-1192-00
-9	131-1012-00			1						CONN, PLUG, ELEC:	0000A	F1304TPX
-10	206-0186-02			1						TIP, PROBE:	80009	206-0186-02
	070-1756-00			1						MANUAL, TECH: INSTRUCTION (NOT SHOWN)	80009	070-1756-00