

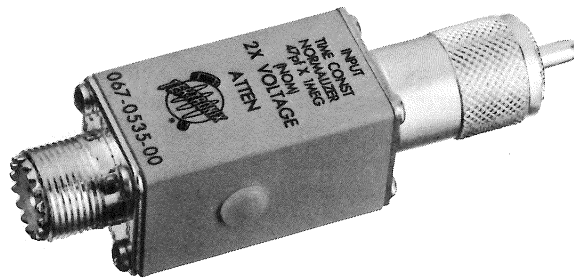

067-0535-00 CALIBRATION FIXTURE

Input Normalizer 47 pF (UHF)



REF. NO.	PART NO.	SERIAL/MODEL NO.		QTY.	DESCRIPTION
		EFF.	DISC.		
	067-0535-00				<p>An Input RC time Constant Normalizer for signal inputs having nominal 1 megohm x 47 pF input RC time constant and having UHF connectors.</p> <div style="border: 1px solid black; padding: 5px; width: fit-content; margin-left: auto; margin-right: auto;"> <p>DATA SHEET NO.</p> <p>062-0841-00 APRIL 1967</p> </div> <p style="text-align: right; font-size: small;">  Copyright © 1967, Tektronix, Inc. All Rights Reserved. </p>

OSCILLOSCOPE INPUT NORMALIZERS

Input Normalizers are used for checking or adjusting the input capacitance of oscilloscopes, or oscilloscope plug-in units, where high-impedance attenuator probes may be used. In a sense they are dummy probes. Input capacitance should be adjusted for each setting of the input attenuator switch, so that you will not need to readjust an input probe each time the attenuator setting is changed.

Different oscilloscope types have different nominal values of input capacitance, so require different input normalizers. The Instruction Manual for each Tektronix Oscilloscope identifies which normalizer should be used, if any, and how to use it.

An instruction manual may refer to an Input Normalizer as a Capacitance Standardizer, a Time Constant Standardizer, or as an RC Standardizer. The name was changed to Normalizer to reduce confusion about whether they should be considered a measurement Standard. The Tektronix part number was changed at the same time.

Input Normalizers are not intended to be used to determine whether input capacitance is within certain limits, or whether the RC product of input resistance and input capacitance is within certain limits. Therefore, they are not intended to be measurement Standards. Furthermore, it is not advisable to attempt to maintain the input capacitance or the input RC time constant on different scopes to tight tolerances with the hope of obviating the need to check or adjust a probe when it is used with a different oscilloscope. Proper probe adjustment should always be checked each time a probe is connected to a different oscilloscope or plug-in unit. When this practice is

observed, fewer measurement errors will be made than can be prevented by a rigorous program to maintain specific tolerance limits. Nor is it advisable to rely on a known input capacitance, measured at one frequency, to calculate the input loading effects on a signal having a different frequency.

Most Tektronix Input Normalizers never need to be adjusted after they leave the factory. Performance is tested each time one is used, and normally should be considered adequate as long as the adjustable input capacitors in the oscilloscopes have sufficient range.

If readjustment should be necessary, the internal resistor should first be measured to be sure it is in tolerance. Then the internal variable capacitor may be adjusted to produce a square-cornered flat-topped response to a square-wave signal on an oscilloscope it is designed to be used with, in the same way as described in the instructions for adjusting scope input capacitance. The response of the scope to square waves should first be known to be normal, and the input capacitance to the scope should be known to be within about five per cent of its nominal value at the attenuator setting used. It is normal for input capacitance to vary slightly from one setting to the next to correspond with slight variations of input resistance. A Tektronix Type 130 L-C Meter may be used to measure the scope input capacitance. Measurement should be made while the scope is operating. When using the Type 130, to avoid a small possibility of a measurement error due to overdriving the input, it is a good idea to use an attenuator setting that corresponds to a deflection factor of about 1 volt per division.

MECHANICAL PARTS LIST-067-0535-00

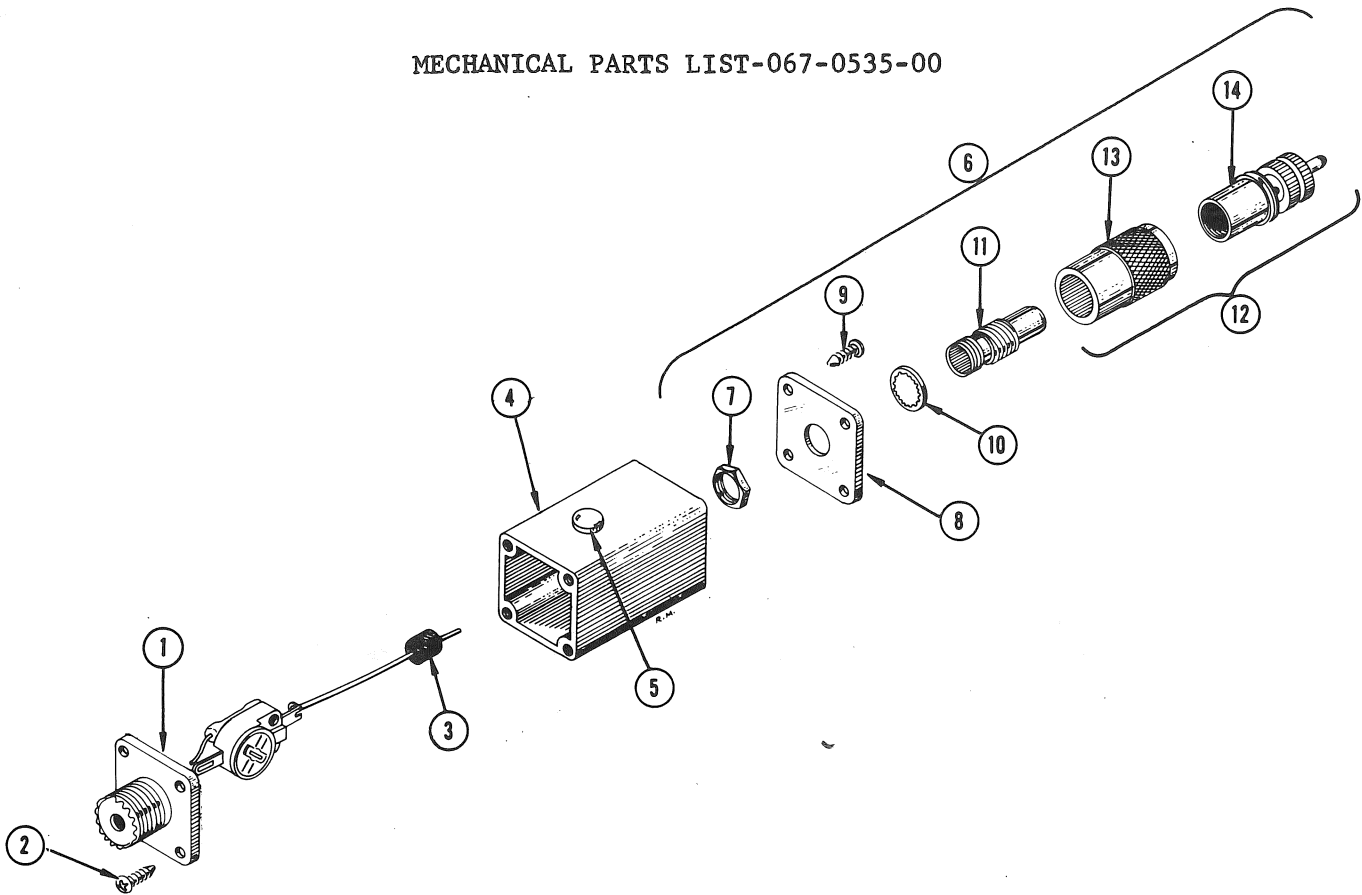
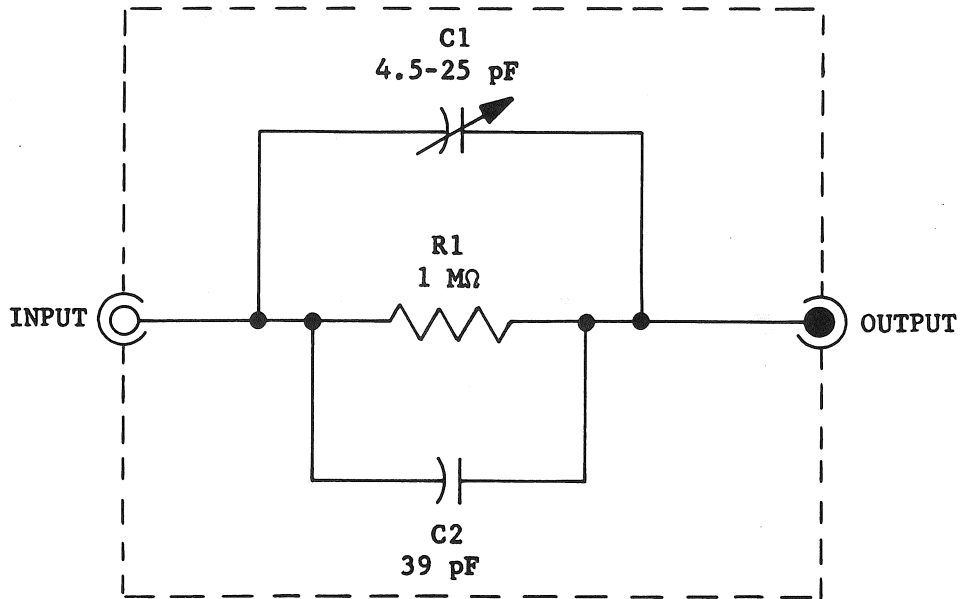

FIG. & INDEX NO.	TEKTRONIX PART NO.	SERIAL/MODEL EFF DISC	Q T Y	DESCRIPTION
1	131-0051-00		1	CONNECTOR, coaxial, 1 contact, UHF
	- - - - -		-	mounting hardware: (not included w/connector)
2	213-0045-00		4	SCREW, self tapping, 4-40 x 5/16 inch, PHS
3	384-0120-00		1	ROD, spacing, plastic
4	204-0298-00		1	BODY, normalizer
5	134-0025-00		1	PLUG, plastic
6	131-0066-00		1	ASSEMBLY, connector, coaxial
	- - - - -		-	assembly includes:
7	210-0413-00		1	NUT, hex., 3/8-32 x 1/2 inch
8	386-0342-00		1	PLATE, adapter
	- - - - -		-	mounting hardware: (not included w/plate)
9	213-0045-00		4	SCREW, self tapping, 4-40 x 5/16 inch, PHS
10	210-0012-00		1	LOCKWASHER, internal, 3/8 ID x 1/2 inch OD
11	102-0006-00		1	REDUCER
12	131-0058-00		1	ASSEMBLY, connector, male, 1 contact
	- - - - -		-	assembly includes:
13	200-0026-00		1	COVER, connector
14	131-0196-00		1	CONNECTOR, 1 contact, male

ELECTRICAL PARTS LIST-067-0535-00



Values are fixed unless marked Variable

Ckt. No.	Tektronix Part No.	Serial/Model No. Eff	Disc	Description			
Capacitors							
C1	281-0010-00	4.5-25 pF	Var	Cer			
C2	281-0517-00	39 pF		Cer	500 V		10%
Resistor							
R1	323-0481-00	1 MΩ	1/2 W	Prec			1%