

010-0264-01

TEKTRONIX®

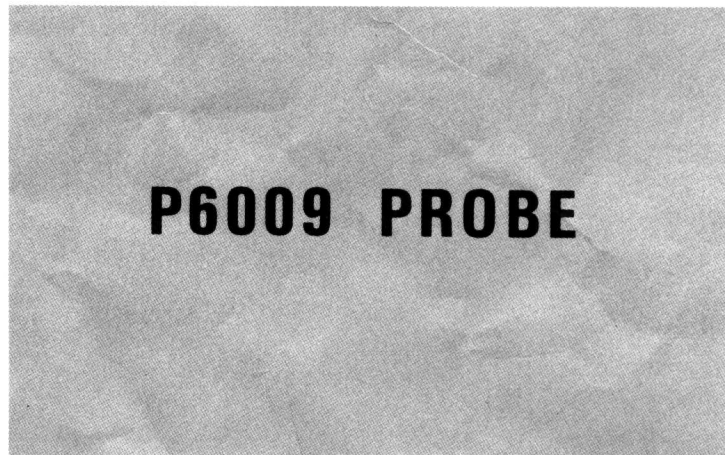

INSTRUCTION MANUAL



WARRANTY

All TEKTRONIX instruments are warranted against defective materials and workmanship for one year. Any questions with respect to the warranty should be taken up with your TEKTRONIX Field Engineer or representative.

All requests for repairs and replacement parts should be directed to the TEKTRONIX Field Office or representative in your area. This will assure you the fastest possible service. Please include the instrument Type Number or Part Number and Serial Number with all requests for parts or service.

Specifications and price change privileges reserved.

Copyright © 1964, new material copyright 1972 by Tektronix, Inc., Beaverton, Oregon. Printed in the United States of America. All rights reserved. Contents of this publication may not be reproduced in any form without permission of Tektronix, Inc.

U.S.A. and foreign TEKTRONIX products covered by U.S. and foreign patents and/or patents pending.

U.S. patent numbers 2,883,619 and 3,532,982.

TEKTRONIX is a registered trademark of Tektronix, Inc.

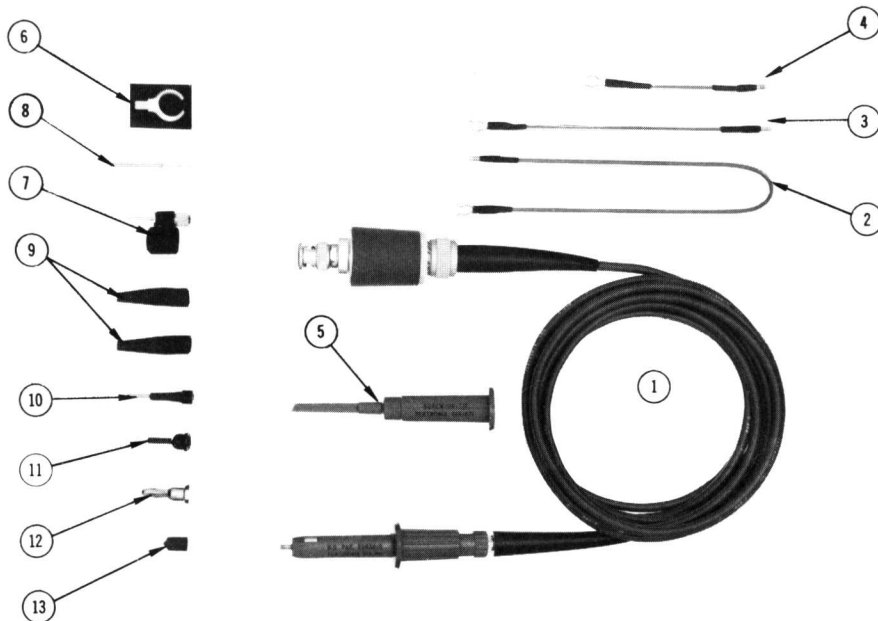

Fig. 1. P6009 Probe and Standard Accessories.

Fig. & Index No.	Tektronix Part No.	Serial/Model No.		Q t y	Description
		Eff	Disc		
PROBE PACKAGE					
1-13	010-0264-01			1	PROBE PACKAGE, P6009 Readout BNC
	010-0170-00			-	PROBE PACKAGE, P6009 Stnd BNC
	-----			-	probe package includes:
PROBE ONLY					
1	010-0264-00			1	PROBE, P6009, Readout BNC
	010-0171-00			1	PROBE, P6009 Stnd BNC
STANDARD ACCESSORIES					
2	175-0125-00			1	CABLE, ground lead, 12 inches
3	175-0124-00			1	CABLE, ground lead, 5 inches
4	175-0263-00			1	CABLE, ground lead, 3 inches
5	013-0071-00			1	PINCHER TIP
6	352-0090-00			1	HOLDER, probe
7	013-0052-00			1	ASSEMBLY, bayonet ground
	-----			-	assembly includes:
8	214-0325-00			1	PIN, center
9	344-0046-00			2	CLIP, probe
10	206-0060-00			1	TIP, probe, male, w/6-32 threads
11	206-0105-00			1	TIP, probe, w/6-32 threads
12	134-0013-00			1	PLUG, banana, female, w/6-32 threads
13	206-0015-00			1	TIP, w/straight shank
--	070-0401-01			1	MANUAL, instruction (not shown)

P6009 PROBE

CHARACTERISTICS

General Information

The P6009 is a low-input-capacitance, high-voltage passive probe with a signal attenuation of 100X. It is designed for use with wide-band, real-time oscilloscopes, and may be used with any plug-in unit or oscilloscope having a 1-megohm input resistance and an input capacitance of 15 to 47 pF.

The probe is available with a standard BNC output connector or with a special BNC connector for readout oscilloscopes. The readout version is recommended for use only with a TEKTRONIX 7000-Series Mainframe (with readout) or the TEKTRONIX 485 Oscilloscope. When used with these instruments, the special connector on the probe causes the oscilloscope readout to switch, automatically correcting for attenuation of the probe.

The P6009 consists of a probe-body assembly, a 9-foot cable, and a compensating-box assembly with a BNC connector. The compensating box houses adjustments for optimizing the high-frequency response of the probe.

SPECIFICATIONS

Electrical

Attenuation: 100X within 3% (including 1 M Ω , \pm 2% amplifier input).

Input Resistance: 10 M Ω within 2% (includes input R of amplifier). See X_p, R_p vs. Frequency curves.

Input Capacitance: Approximately 2.5 pF.

Compensation Range: 15 pF or less to at least 47 pF.

Bandwidth (–3 dB): At least 120 MHz (with a 7A16 Amplifier and a 7704 Mainframe).

Maximum Input Voltage: 1.5 kV (DC or RMS), derated with frequency. See derating curve.

Physical

Weight: Approximately 8 oz., net.

Dimensions:

PROBE BODY: \approx 4 inches, length; \approx 0.8 inch, maximum outside diameter.

CABLE: \approx 9 feet between strain relief bases.

COMPENSATION BOX: \approx 2.9 inches, length; \approx 1.2 inches, maximum outside diameter.

Environmental

Probe will operate within specifications over the following ranges:

Temperature: –15°C to +75°C.

Altitude: To 15,000 feet.

OPERATING INSTRUCTIONS

Introduction

The P6009 Probe provides a means of connecting an oscilloscope to a test point with minimum loading and without need for impedance matching. Tip accessories supplied with the P6009 Probe Package adapt the probe tip for a variety of signal connections.

Probe Compensation

Input capacitance of amplifiers varies from unit to unit (even of the same type). This variation makes it necessary to compensate the probe whenever it is transferred from one instrument to another, or from one channel to another of multi-trace units. Improper compensation will produce waveshape distortion and/or amplitude measurement error of the display. See Compensation Procedure for method of adjustment.

Circuit Loading

Any high-impedance circuit will be loaded to some extent by connecting a probe, even though the DC input

resistance of the probe is 10 MΩ. At relatively low frequencies, the input capacitance of a probe causes greater loading than the DC input resistance. For example, the input impedance of the P6009 drops to approximately 50 kΩ at 1 MHz.

Circuit loading may cause signal distortion or amplitude measurement error. To minimize this loading effect, select the lowest impedance points to check waveforms.

Fig. 2 shows R_p and X_p as a function of frequency. These curves should be referred to when making measurements of AC signals, especially in high-impedance circuits.

Maximum Input Voltage

The maximum safe input voltage for the P6009 Probe is 1.5 kV (DC or RMS) at low frequencies. As signal frequency increases, input capacitive reactance decreases, reducing the maximum safe input voltage. Fig. 3 shows a typical maximum input voltage vs. frequency curve.

Signal Connections

The probe may be connected to the signal source by means of the tip adapters and ground leads supplied. Generally, select the adapter and lead that is best suited physically for the particular type of test point. When measuring high-frequency signals, use the shortest ground lead possible. Long ground leads tend to cause ringing due to the inductance of the lead. Similarly, extensions to the

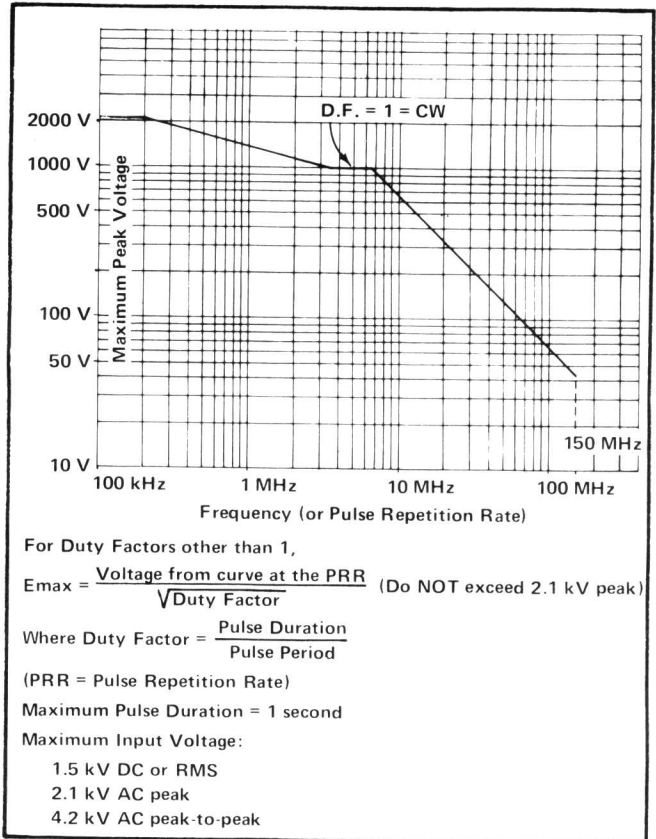

Fig. 3. P6009 Probe, maximum input voltage versus frequency.

probe tip must be held to a minimum for high-frequency measurements.

Always provide some form of ground connection between the circuit under test and the probe ground to prevent hum pickup, ringing, and other spurious signals. The 5-inch and 12-inch ground leads clip to the bushing at the rear of the probe body. The 3-inch ground lead is used with the bayonet ground assembly. See Fig. 4.

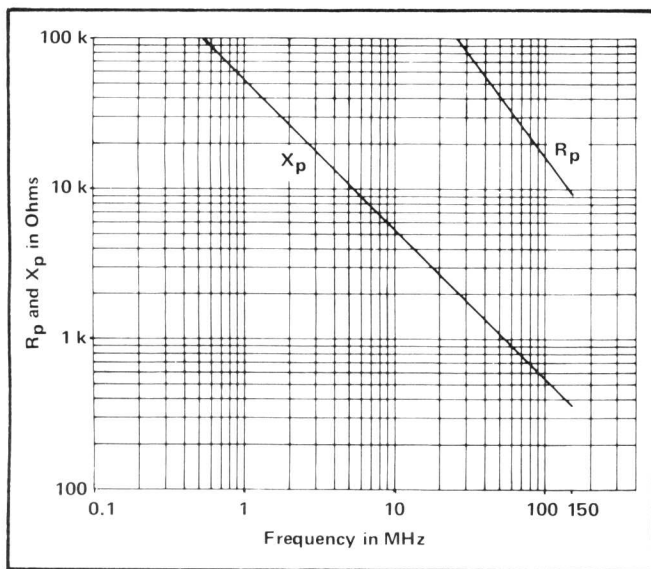

Fig. 2. P6009 Probe, typical X_p and R_p versus frequency curves.

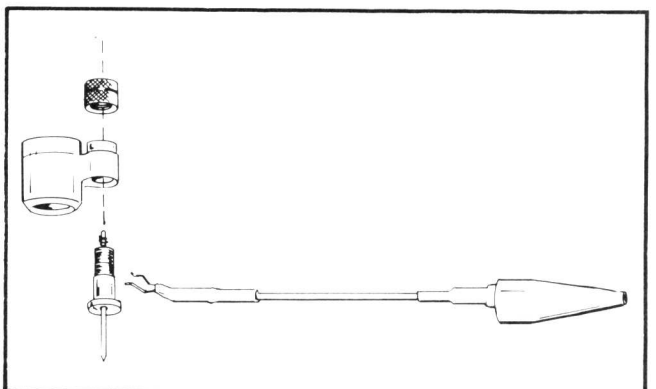

Fig. 4. Connecting 3-inch ground lead to bayonet ground assembly.

Additional Reference Information

If you desire further information on probe applications and measurement evaluation techniques, the following booklet is available:

Measurement Concept Booklet; Probe Measurements, TEKTRONIX Part Number 062-1120-00.

COMPENSATION PROCEDURE

Introduction

The P6009 Probe is inherently stable and does not require frequent re-compensation once it has been adjusted to the oscilloscope that it is being used with. However, if the probe is transferred from one instrument or input channel to another, the low-frequency compensation will usually require readjustment. If the probe is to be used in observing or measuring sinewaves or pulses with frequency components above 3 or 4 MHz, high-frequency compensation should also be checked and adjusted as necessary.

Since the P6009 may be used with a broad variety of oscilloscopes and plug-in units, the following procedure is stated in general terms with regard to settings of test instrument controls, etc.

Equipment and Test Fixtures Required

All items on the following list (or equivalents) are required to perform the complete compensation procedure.

If only the low-frequency compensation is to be adjusted, just the test oscilloscope is required. For convenience in connecting the probe tip, the probe tip-to-BNC adapter (item no. 8) is also recommended.

1. Test oscilloscope (and plug-in unit, if appropriate) of the same type that the P6009 will be used with.

2. Pulse or Squarewave Generator. Risetime should be less than any signal to be measured with the oscilloscope/P6009. TEKTRONIX Type 106 Squarewave Generator or Type 109 Pulse Generator recommended.

3. Cable, 5 ns, 50 Ω coaxial Type RG58C/U with GR connectors; TEKTRONIX Part No. 017-0512-00.

4. Attenuator, 10X, 50 Ω with GR connectors; TEKTRONIX Part No. 017-0078-00. (Two required.)

5. Termination Adapter, 50 Ω thru-line, GR-to-BNC male; TEKTRONIX Part No. 017-0083-00.

6. Adapter, GR-to-BNC female; TEKTRONIX Part No. 017-0063-00.

7. Termination, 50 Ω feedthrough with BNC connectors; TEKTRONIX Part No. 011-0049-01.

8. Adapter, Probe tip-to-BNC; TEKTRONIX Part No. 013-0054-00.

9. Small non-conducting screwdriver.

Preliminary Procedure

a. Install the P6009 Probe on the oscilloscope input connector.

b. Turn the test oscilloscope and associated test equipment power on and allow enough warmup time for the equipment to stabilize.

1. Adjust Low-Frequency Compensation

a. Connect the probe tip to the test oscilloscope calibrator output, using the Probe tip-to-BNC Adapter.

b. Set the test oscilloscope Volts/Div fully clockwise. The calibrator amplitude should be set to provide a display amplitude of several divisions. Set the Time/Div and triggering controls to display several cycles of the square-wave signal.

c. Hold the probe body and tip assembly and loosen the locking sleeve several turns (see Fig. 5).

d. Hold the base bushing and turn the probe body and tip assembly to obtain a flat-topped squarewave display, free of overshoot or rounding at the leading corner (see Fig. 5).

e. Hold the probe body and tip assembly and carefully tighten the locking sleeve while observing the display.

If the probe changes adjustment while tightening the locking sleeve, continue turning the sleeve until it is just tight. The final adjustment may be accomplished by

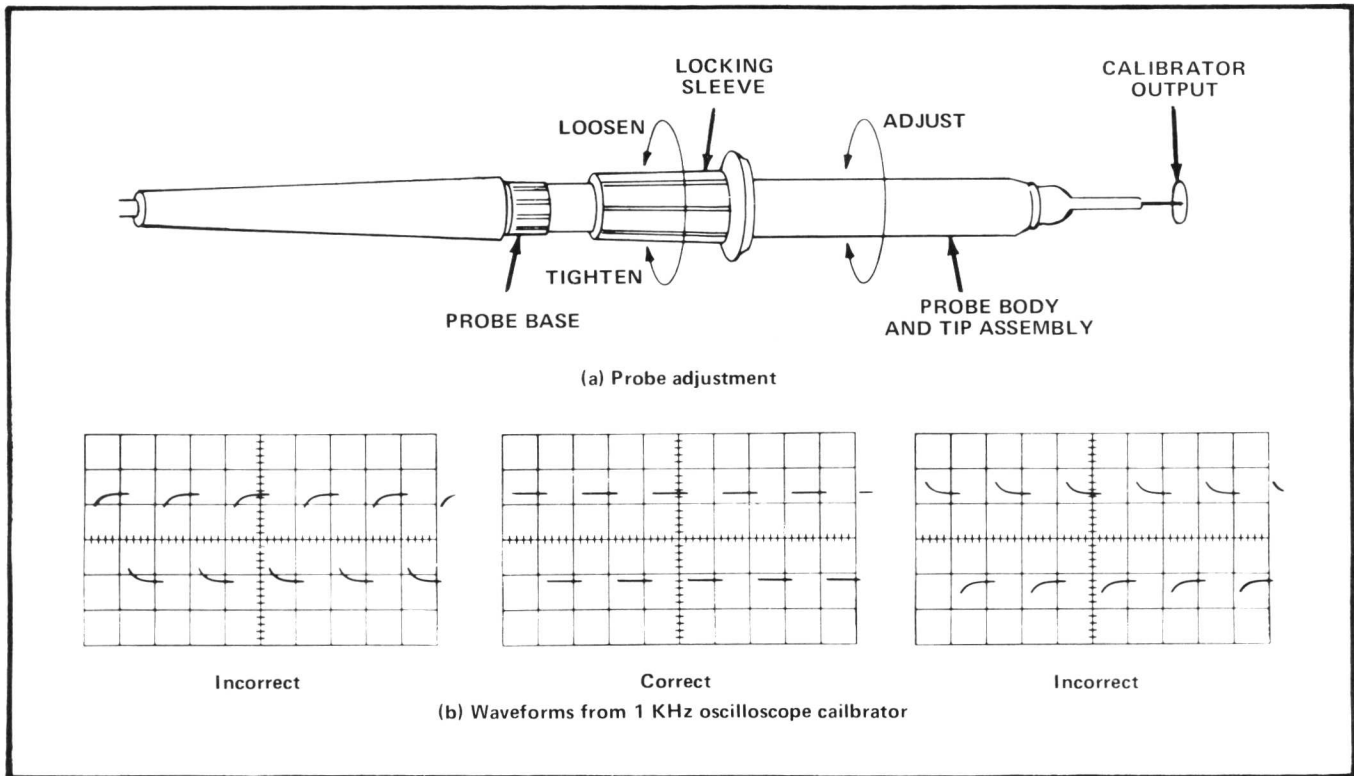

Fig. 5. Probe L.F. Compensation.

holding the probe body and the locking sleeve and then turning the base bushing slightly to obtain the correct display.

2. Check/Adjust High-Frequency Compensation

a. Step 1 (Low-Frequency Compensation) should be performed before starting this step. Then, check the pulse response of the test oscilloscope. Use a 10X attenuator (item no. 4) at each end of the cable which connects the pulse generator to the oscilloscope input. This will provide the same attenuation as the probe (100X), resulting in a similar display amplitude. A termination adapter (item no. 5) should be used at the oscilloscope input.

Set the test oscilloscope Time/Div to 50 ns and note the pulse shape and aberrations. Change the Time/Div to 200 ns and note the level of the first few millimeters of the pulse with respect to the rest of the pulse.

b. Disconnect the cable, attenuators, and termination adapter from the test oscilloscope and the pulse generator. Install the P6009 Probe on the oscilloscope input connector.

c. Connect the probe tip to the pulse generator output, using Fig. 6 as a guide.

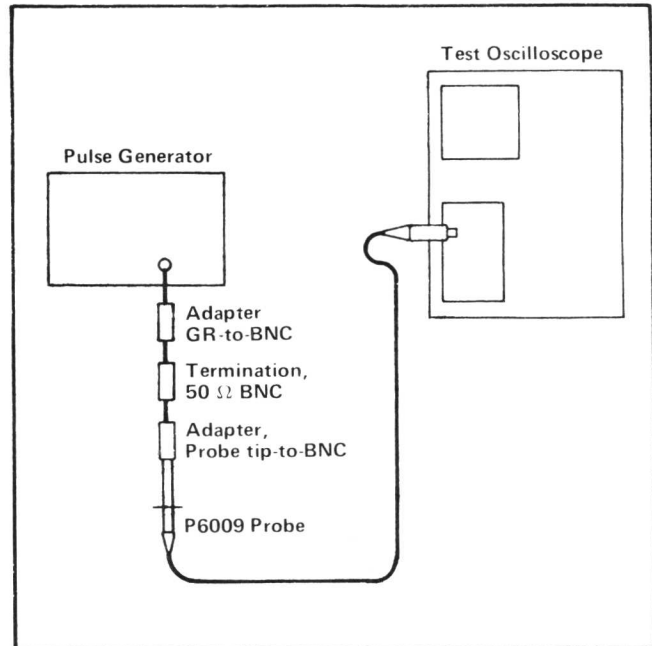

Fig. 6. Equipment connections for checking pulse response of the P6009 Probe.

d. Check the pulse response of the probe at 50 ns/Div and 200 ns/Div, comparing with the pulse shape noted in Part a. Aberrations should not typically exceed ±5% of the

P6009 Probe

pulse amplitude (from the reference response noted in Part a).

If aberrations are excessive, continue with the following steps.

e. Loosen the Locking Nut and slide the Compensating Box Cover back onto the cable.

f. Connect the probe tip to the test oscilloscope calibrator output, using the Probe tip-to-BNC Adapter. Set the calibrator to provide a display amplitude of several divisions. Set the Time/Div to display several cycles of the squarewave signal.

g. Set C114 (see Fig. 7) for maximum rolloff on the leading corners of the squarewave.

h. Adjust the probe low-frequency compensation (per Step 1) for a square leading corner on the display.

i. Disconnect the probe from the calibrator output and connect as shown in Fig. 6. Set the oscilloscope Time/Div to 50 ns.

j. Adjust R110, R114, and R116 for the best overall flat response. Check for proper level with Time/Div at 200 ns, readjusting as necessary. Fig. 7 shows the location of adjustments in the compensating box.

k. Replace the cover on the compensating box and tighten the locking nut.

l. Readjust the probe low-frequency compensation (using the calibrator squarewave signal).

This completes the compensation procedure for the P6009 Probe.

MAINTENANCE

General Information

The P6009 Probe is designed to withstand normal operation and handling and should give many hours of continuous use without failure. However, if the probe fails or suffers physical damage, replacement parts are available. See mechanical and electrical parts lists at the rear of this manual.

Probe Body Assembly

The Probe Body Assembly includes the five components shown in the exploded view (rear of this manual) identified as Ref Nos. 12 through 16. If the 9.9 M Ω resistor (R100) fails, replace the Body and Tip Assembly, Ref. No. 12. The resistor is factory-installed in this assembly.

Compensating-Box Assembly

To obtain access to components within the compensating-box assembly, turn the locking nut (located at the rear of the box) counterclockwise until it is free. Then, slide the box cover and the locking nut back on the cable.

All electrical components in the compensating box are mounted on the circuit board. The complete circuit board with electrical components may be ordered under the indicated part number, or the individual electrical components may be ordered, using part numbers from the electrical parts list.

The output BNC connector is shown in two versions. One is the standard BNC connector, and the other is the special BNC for readout. The readout resistor (R118) is located within the connector.

Cable Assembly Replacement

If the coaxial cable between the probe body and the compensating box should fail, the Cable Assembly is available, complete with fittings and cable reliefs.

Replace the cable assembly as follows:

1. Remove the Compensating Box Cover by unscrewing the Locking Nut that holds it in place (see Fig. 7).

2. Unsolder the bare wire from the center terminal of the Cable Assembly (next to R114).

3. Use thin 7/16-inch and 9/16-inch open-end wrenches to remove the Cable Assembly from the Compensating Box.

4. Turn the Locking Sleeve to unlock the Probe Body and Tip Assembly and remove both by unscrewing from the end of the Base Bushing Assembly (see exploded view in rear of manual).

5. Unscrew the Tube Sleeve from the plastic Inner Base Bushing.

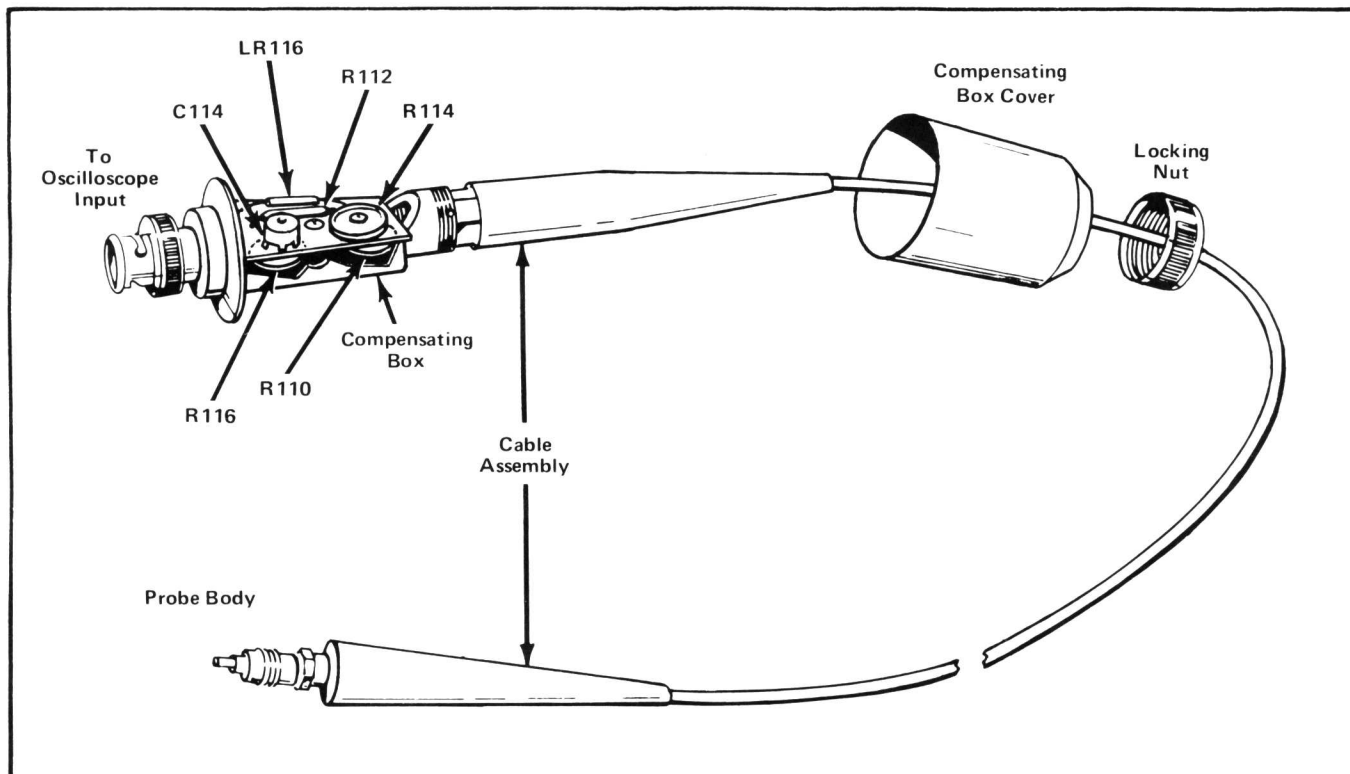

Fig. 7. P6009 Probe, H.F. compensating assembly.

6. Use thin 11/32-inch and 3/8-inch open-end wrenches to remove the Base Bushing from the end of the Cable Assembly.

8. Unsolder the bare wire from the center terminal of the Cable Assembly.

7. Use a scribe to lift the wire from the thread groove of the Inner Base Bushing and remove the bushing.

9. To install the new Cable Assembly, perform steps 1 through 8 in reverse order.

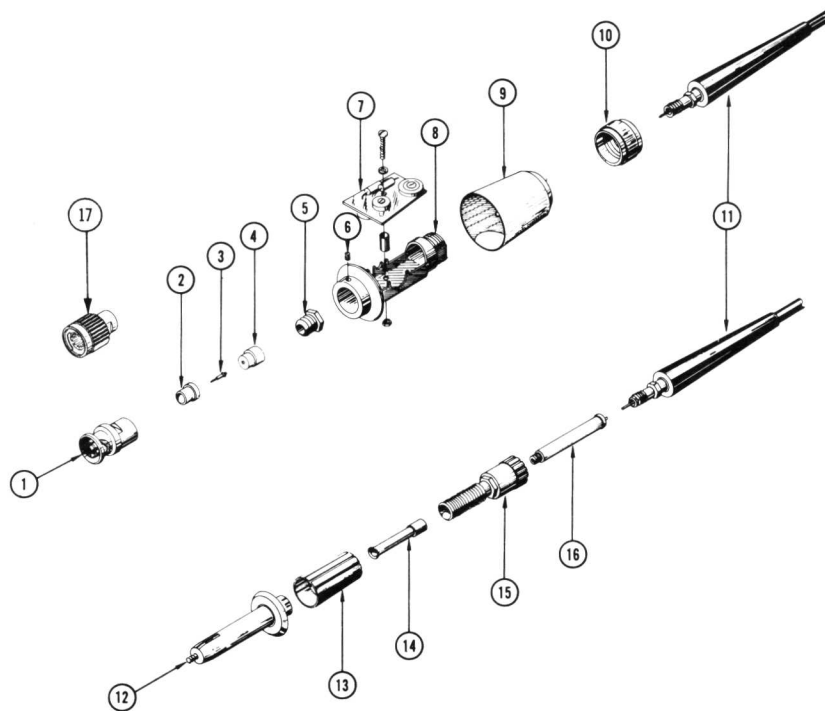
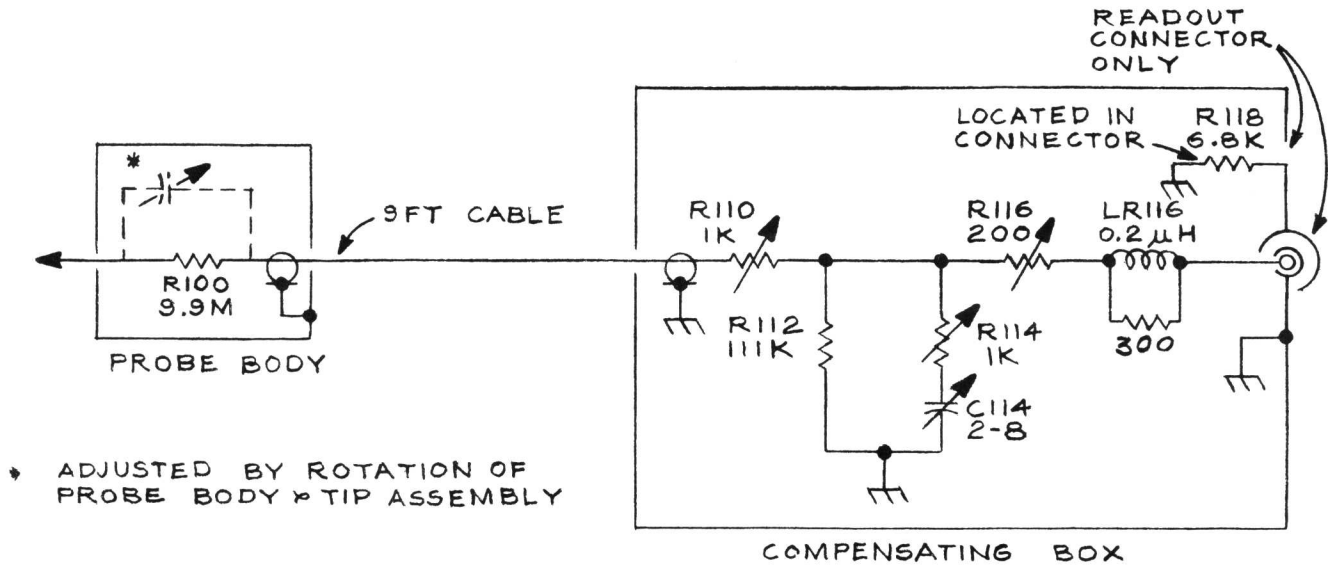

Fig. 8. Exploded view.

Fig. & Index No.	Tektronix Part No.	Serial/Model No.		Q	Description
		Eff	Disc		
	131-0428-00			1	CONNECTOR, receptacle, BNC (010-0170-00 Only)
1	134-0044-00			1	CONNECTOR, receptacle, BNC (010-0170-00 Only) connector includes:
2	358-0072-00			1	PLUG, probe
3	214-0109-00			1	BUSHING, insulator
4	166-0217-00			1	PIN, probe contact, male
5	132-0081-00			1	TUBE, spacer, insulator
6	213-0020-00			1	NUT
7	388-0555-00			1	SCREW, set, 6-32 x 1/8 inch, HSS
	-----			1	ASSEMBLY, circuit board, wired
	211-0014-00			1	mounting hardware: (not included w/assembly)
	210-0004-00			1	SCREW, 4-40 x 1/2 inch, PHS
	210-0406-00			1	LOCKWASHER, internal No. 4
	166-0233-00			1	NUT, hex., 4-40 x 3/16 inch
				1	TUBE, spacer, 5/16 inch long
8	204-0178-00			1	BODY, compensator
9	205-0046-00			1	SHELL, compensator
10	210-0576-00			1	NUT, locking
11	175-0268-00			1	CABLE ASSEMBLY, BNC, 9 foot
12	204-0545-01			1	BODY ASSEMBLY
13	166-0285-00			1	SLEEVE, locking
14	166-0349-00			1	SLEEVE, tube, 1 1/4 inches long
15	358-0194-00			1	BUSHING, base
16	358-0192-00			1	BUSHING, inner base
17	131-0944-00			1	CONNECTOR, plug, readout (010-0264-00 Only)

P6009 SCHEMATIC



ELECTRICAL PARTS

Ckt. No.	Tektronix Part No.	Description			
Capacitor					
C114	281-0060-00	2-8 pF	Cer	Var	
Inductor					
LR116	108-0425-00	0.2 μH	Wound on 300 Ω ¼ W resistor		
Resistor					
R100 ¹					
R110	311-0436-00	1 kΩ		Var	
R112	318-0006-00	111 kΩ	1/8 V		Prec 1%
R114	311-0436-00	1 kΩ		Var	
R116	311-0411-00	200 Ω		Var	
R118 ²					

¹ Furnished as a unit with Probe Body and Tip Assembly.

² Furnished as a unit with Readout Connector only.

All other electrical parts are furnished with circuit board when ordered as ASSEMBLY, Part No. 388-0555-00.