

INSTRUCTION MANUAL

Serial Number 1329

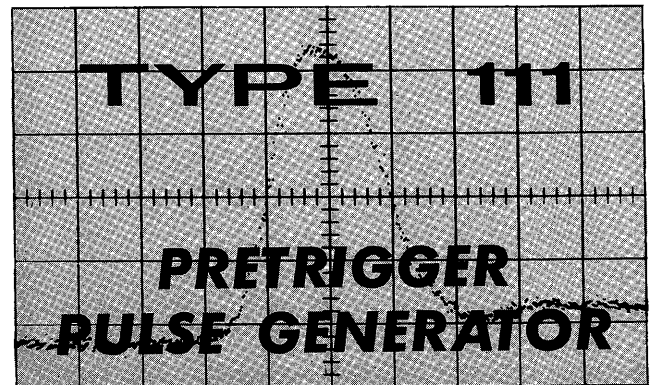

Tektronix, Inc.

S.W. Millikan Way ● P. O. Box 500 ● Beaverton, Oregon 97005 ● Phone 644-0161 ● Cables: Tektronix



WARRANTY

All Tektronix instruments are warranted against defective materials and workmanship for one year. Tektronix transformers, manufactured in our own plant, are warranted for the life of the instrument.

Any questions with respect to the warranty mentioned above should be taken up with your Tektronix Field Engineer.

Tektronix repair and replacement-part service is geared directly to the field, therefore all requests for repairs and replacement parts should be directed to the Tektronix Field Office or Representative in your area. This procedure will assure you the fastest possible service. Please include the instrument Type and Serial number with all requests for parts or service.

Specifications and price change privileges reserved.

Copyright © 1960, new material copyright © 1965 by Tektronix, Inc., Beaverton, Oregon. Printed in the United States of America. All rights reserved. Contents of this publication may not be reproduced in any form without permission of copyright owner.



CONTENTS

Warranty

- Section 1 Characteristics
- Section 2 Operating Instructions
- Section 3 Circuit Description
- Section 4 Maintenance
- Section 5 Calibration
- Section 6 Parts List and Diagrams

A list of abbreviations and symbols used in this manual will be found on page 6-1. Change information, if any, is located at the rear of the manual.



TYPE 111 PRETRIGGER PULSE GENERATOR

RISE TIME ≤ 0.5 NANOSEC

SERIAL

PULSE GENERATOR

REPETITION RATE

1 TO 10

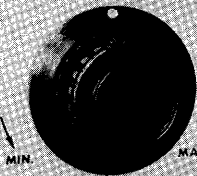

RANGE

100 CPS

10 CPS

1 KC

EXT. TRIG.

10 KC

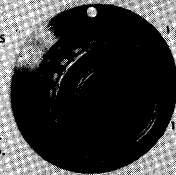

OUTPUT POLARITY

+

-

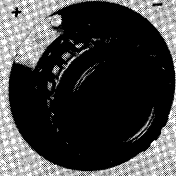

POWER ON



TEKTRONIX, INC., PORTLAND, OREGON, U.S.A.

TRIGGER TO PULSE TIME DIFFERENCE

VARIABLE

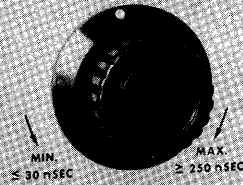

MIN.

≤ 30 nSEC

MAX.

≥ 250 nSEC

FIXED INCREMENT

+1 nSEC

0



AVALANCHE ADJUST



TRIG. SENS. ADJUST



SECTION 1

CHARACTERISTICS

General Description

The Tektronix Type 111 Pretrigger Pulse Generator is a fast-rise pulse generator providing two pulse outputs—a positive-going Pretrigger Pulse and a positive- or negative-going Output Pulse—at repetition rates from 10 cps to 100 kc. When the Type 111 is triggered by an external signal instead of the internal repetition rate generator, the rate can be as low as a single pulse. External triggering also provides a means of synchronizing the output pulses with an external signal.

The Pretrigger Pulse produced prior to each Output Pulse is convenient for triggering either a conventional or a sampling oscilloscope. The amount of delay between the Pretrigger and the Output Pulse may be varied from 30 to 250 nanoseconds by means of a front-panel control. In many applications, triggering with the Pretrigger Pulse will eliminate the need for external cables to delay the vertical input signal.

OUTPUT PULSE

Risetime (10-90%)

Equal to or less than 500 picoseconds* (0.5 nsec), either positive-going or negative-going**.

Amplitude

Equal to or greater than ± 10 volts**. Typically ± 12 to ± 15 volts, depending on the characteristics of the avalanche transistor and the setting of the avalanche adjustment. Output Pulse amplitude may be reduced with 50-ohm attenuators connected externally.

Duration (at 50% level)

Minimum—2 nanoseconds, using no external charge line.

Maximum—Using external charge lines: 33 nanoseconds** at full 100-kc repetition rate; longer duration at lower repetition rates. Up to 1.5 microseconds** at 1 kc or less. See graph in Operating Instructions section for pulse duration limits at various repetition rates.

Polarity

Either + or — as selected by a front-panel switch.

*Determined from observed system risetime of 615 psec using a Tektronix sampling oscilloscope with a risetime of 350 psec. See Calibration section.)

**S/N 101-799:

Amplitude is ± 5 volts or greater;

Risetime of negative-going pulse may be slightly more than 500 psec;

Output Pulse maximum duration is 20 nanoseconds at 100-kc repetition rate, increasing to 142 nanoseconds at 15 kc or less;

Output Pulse tilt is less than 10% of pulse amplitude.

Aberrations

Front corner and pulse top aberrations and tilt—less than 5%** of pulse amplitude when output is properly terminated (output load is 50 ohms).

Baseline aberrations following pulse—less than 10% of pulse amplitude when output is properly terminated (50-ohm load) and charge line is high-quality 50-ohm cable.

Repetition Rate

10 cps to 100 kc, selected by a front-panel range switch and variable control. The variable control provides a slight overlap between ranges. Rate is variable from zero (single pulses) to 100 kc when triggered with an external signal.

Output Impedance

Nominally 50 ohms.

Pretrigger to Output Pulse Delay Time

Variable—30 to 250 nanoseconds, adjusted by a front-panel control.

Fixed Increment—1 nanosecond $\pm 10\%$, inserted with a front-panel switch.

Jitter—Less than 100 picoseconds time jitter between Pretrigger and Output Pulse.

PRETRIGGER PULSE

Risetime (10-50%)

Equal to or less than 7 nanoseconds.

Amplitude

+10 volts $\pm 20\%$, peak-to-peak.

Duration (Width)

300 nanoseconds $\pm 20\%$.

Repetition Rate

Equal to repetition rate of Output Pulse.

Output Impedance

Nominally 50 ohms.

Characteristics—Type 111

EXTERNAL TRIGGER REQUIREMENTS

Amplitude

Minimum— +3 volts.

Maximum— +50 volts.

Minimum Rate of Rise

3 volts/ μ sec.

Repetition Rate

Minimum—Single pulse.

Maximum—100 kc.

OTHER CHARACTERISTICS

Instrument Power

Line Voltage—105 to 125 volts (nominal 117 volts) or 210 to 250 volts (nominal 234 volts) single-phase ac.

Power Consumption—Approximately 30 watts.

Fuse—0.4-amp slow-blowing type for 117-volt operation.
0.2-amp slow-blowing type for 234-volt operation.

Mechanical Characteristics

Construction—Aluminum-alloy chassis and cabinet. Side panels separately removable. Anodized front and rear panels; blue vinyl paint on remainder of cabinet.

Dimensions: Width—7 inches; height—11 inches; depth—11 inches.

Standard Accessories

Information on accessories for use with this instrument is included at the rear of the mechanical parts list.

SECTION 2

OPERATING INSTRUCTIONS

General Information

The Type 111 is a fast-rise pulse source designed primarily for use with an oscilloscope when testing other devices. The Type 111 also generates pretrigger pulses for triggering the oscilloscope in time to display the pulse rise.

Output pulse risetime is less than 500 picoseconds. Output pulse polarity and repetition rate, as well as pretrigger to pulse time delay, are adjusted with front-panel controls.

This section of the manual describes the basic operation of the Type 111 and also includes some basic information required for connecting the instrument to the oscilloscope and to other equipment.

INSTALLATION

Cooling

The Type 111 is air-cooled by convection currents passing through the bottom and side panels. Place the instrument where it will have at least 2 inches of clearance on each side so that air can circulate freely. Ambient air temperature should not exceed 122° F.

Power Requirements

This instrument is wired to operate on the line voltage indicated on a metal tag near the rear-panel power plug. When wired for 117 volts, the instrument will operate properly on line voltages from 105 to 125 volts. When wired for 234 volts, it will operate properly on voltages from 210 to 250 volts. Line frequency must be between 50 and 800 cps.

The transformer primary is designed for convenient conversion to either 117 volts or 234 volts nominal line voltage. To convert from one line voltage to the other, change the transformer primary connections as indicated on the Pulse Generator schematic diagram at the rear of this manual. Only the bus wires connected to terminals 1, 2, 3 and 4 will have to be moved. Replace the power-line fuse (F601), as listed in the Parts List, to correspond to the new line voltage.

If the transformer is reconnected to operate on a different line voltage, the voltage tag on the rear panel should also be replaced or modified. Either reverse the old tag and mark the new voltage on the blank side, or cover or replace the old tag with a new one providing the correct voltage information. (Tektronix part number 334-650 for 117 V tag; 334-656 for 234 V tag.)

FUNCTIONS OF CONTROLS AND CONNECTORS

All controls and connectors required for operation of the Type 111 are located on the front and rear panels (see Fig. 2-1). The following table briefly describes the functions of these controls and connectors. Further information, if required, is included under appropriate headings later in this section.

Front Panel	
POWER ON switch	Applies line power to transformer primary.
Pilot Light	Indicates that ac power is applied to regulated voltage supply.
Pulse Generator:	
REPETITION RATE control	Varies pulse repetition rate by a factor of 10 over range selected by RANGE switch. At MIN position, repetition rate is less than or equal to rate indicated on RANGE switch; at MAX position, repetition rate is equal to or greater than 10 times rate indicated on RANGE switch.
RANGE switch	Selects pulse repetition rate range from 4 decade steps. Low end of range is indicated on front panel. Rate is varied within selected range by REPETITION RATE control. EXT TRIG position of switch permits triggering of Type 111 from external signal.
OUTPUT POLARITY switch	Selects polarity of Output Pulse appearing at PULSE OUTPUT connector.
Trigger to Pulse Time Difference:	
VARIABLE control	Adjusts delay time between Pretrigger and Output Pulses, from less than 30 nsec (with control at MIN) to greater than 250 nsec (with control at MAX). Positions pulse display in oscilloscope "time window" when oscilloscope is triggered with Pretrigger Pulse.
FIXED INCREMENT switch	Decreases Pretrigger to Output Pulse time delay by approximately 1 nsec with switch in +1 nSEC position. Permits time-shift check of oscilloscope sweep timing ($\pm 10\%$) at 0.2 to 1.0 nsec/div sweep rates.
TRIG SENS ADJUST control	Adjusts trigger sensitivity of Pretrigger Pulse Generator for best triggering from both internal and external sources.
AVALANCHE ADJUST control	Adjusts voltage of output stage for avalanche that produces best Output Pulse characteristics.
Rear Panel	
EXT TRIGGER INPUT connector	BNC connector*. Permits application of external signal for triggering Pulse Generator circuits.

*5/N 101-659: UHF connector.

Operating Instructions—Type 111

Signal requirements:

amplitude—3 to 50 volts
 rate of rise—3 v/ μ sec or faster
 repetition rate—1 pulse to 100 kc

See Fig. 2-2 for minimum amplitude vs. risetime.

PRETRIGGER OUTPUT connector

50-ohm GR. Provides $\approx +10$ -volt Pre-trigger Pulse 30 to 250 nsec before each Output Pulse.

CHARGE LINE connector

50-ohm GR. Provides selection of pulse duration (width) by installing different lengths of open-ended 50-ohm cable. Pulse duration is 2 nsec plus double-transit time of external cable. See Fig. 2-3 for charge line limits at various repetition rates.

PULSE OUTPUT connector

50-ohm GR. Provides fast-rise Output Pulse (typically 12-15 volts) with risetime of 500 psec or less and duration (width) of 2 nsec or more, depending on length of charge line.

FUSE

Prevents overload current through transformer primary. Always use correct fuse for your line voltage (see Parts List).

Power Plug

Applies line voltage through fuse and power switch to transformer primary. Third pin connected to chassis ground.

FIRST-TIME OPERATION

The following procedure illustrates the basic operation of the Type 111 when used with a sampling oscilloscope. A similar procedure can be used with a conventional oscilloscope.

1. With the POWER ON switch turned off (down), connect the Type 111 to the line voltage indicated on the voltage tag near the power plug.

2. Set the Type 111 controls as follows:

REPETITION RATE	Centered
RANGE	10 KC
OUTPUT POLARITY	+
VARIABLE	MIN
FIXED INCREMENT	0

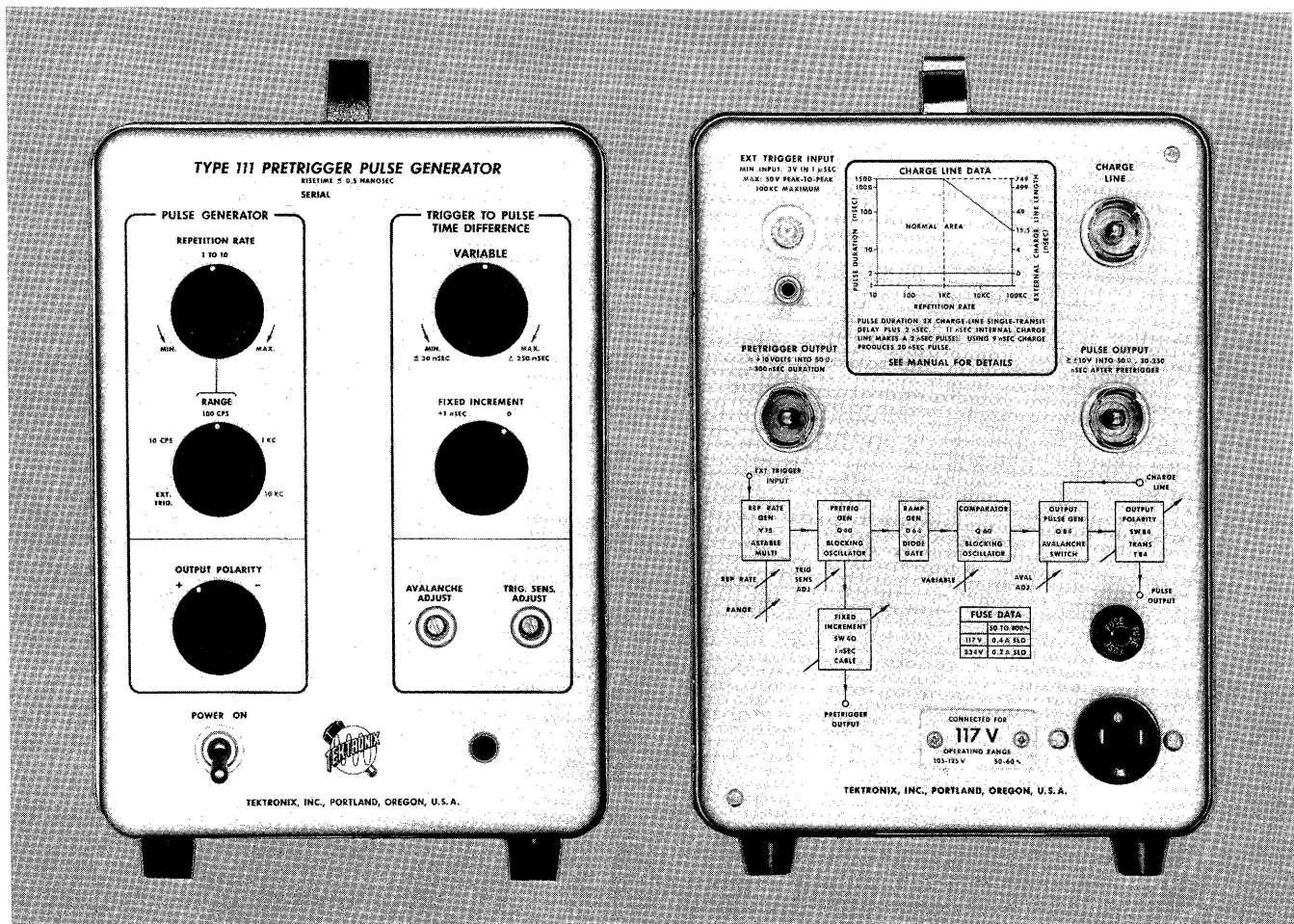

Fig. 2-1. Controls and connectors on front and rear panels.

3. Set up the sampling oscilloscope as described in the instruction manual for the instrument.

4. Set the sampling oscilloscope controls as follows:

Sweep mode	Normal
Magnification	X1
Equiv. sweep rate	20 nsec/div, Calibrated
Sampling rate	100 dots/div
Delay (Time Position)	Centered
Triggering	External +
Vertical mode	A Only, Normal
Deflection Factor	50 mv/div, Calibrated

5. Turn on the Type 111 and the oscilloscope. Allow the instruments to warm up while connecting the signal and triggering cables.

6. Connect a 9-nsec 50-ohm charge line to the CHARGE LINE connector. (This item is a standard accessory with the Type 111.)

7. Install two 10X 50-ohm T-attenuators on the PULSE OUTPUT connector and two 10X 50-ohm attenuators on the PRETRIGGER OUTPUT connector. If four 10X attenuators are not available, use some other combination of attenuators totaling 100X on each connector.

8. Connect the pulse signal from the attenuators on the PULSE OUTPUT connector to the vertical input of the oscilloscope. If the oscilloscope is a 50-ohm sampling system, connect a 50-ohm coaxial cable directly from the attenuators to the vertical input connector. If the oscilloscope is a sampling-probe system, connect the probe tip to the attenuators by means of a probe-tip adapter.

9. Connect a coaxial cable (using adapters as necessary) from the attenuators on the PRETRIGGER OUTPUT connector to the external trigger input of the oscilloscope.

10. Trigger the oscilloscope display. It may be necessary to adjust the oscilloscope positioning and intensity controls to observe the pulse display.

11. Turn the Type 111 VARIABLE control and note that the pulse can be positioned over a "time window" wider than the 200 nsec crt display (with the sweep rate at 20 nsec/div). Further positioning can be done with the oscilloscope Delay (Time Position) control.

12. Set the oscilloscope equivalent sweep rate to 5 nsec/div.

13. Again use the VARIABLE control to position the pulse on the crt screen. Note that the duration of the displayed pulse is approximately 20 nsec. This is equal to the double transit time of the 9-nsec external charge line and the 1-nsec internal charge line between the CHARGE LINE connector and the avalanche transistor.

Adjust Trigger Sensitivity

Adjustment of the front-panel TRIG SENS ADJUST control may be made with either a sampling oscilloscope or a conventional oscilloscope.

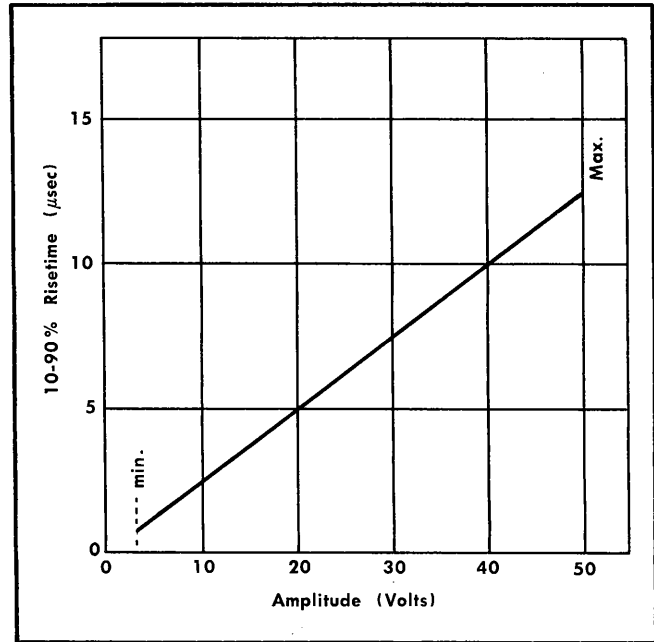

Fig. 2-2. Maximum risetime of external triggering pulse in relation to required pulse amplitude. (Based on 3 volt/µsec minimum rate of rise.)

1. Set the Type 111 controls as follows:

REPETITION RATE	Centered
RANGE	EXT TRIG
TRIG SENS ADJUST	Clockwise

2. If a sampling oscilloscope is used, set up a display of the Output Pulse as described above. The free-running Output Pulse should be presented on the crt screen.

a. Observe the Output Pulse and adjust the TRIG SENS ADJUST control counterclockwise just past the point where the Output Pulses stop. This is the setting for maximum trigger sensitivity, without causing the Pretrigger blocking oscillator to free run.

b. Set the RANGE switch to 10 CPS.

c. Check for stable triggering while varying the pulse repetition rate from 10 cps to 100 kc with the RANGE switch and REPETITION RATE control.

3. If a conventional test oscilloscope is used, set up the oscilloscope and set the controls as follows:

Sweep rate	10 µsec/div
Deflection factor	0.5 volts/div
Triggering	Internal +

a. Install a 10X T-attenuator on the PRETRIGGER OUTPUT connector.

b. Connect the Pretrigger Output signal to the oscilloscope vertical input, either with a coaxial cable and adapter connected to the attenuator, or with a 10X test probe connected to the Pretrigger test point on the Fixed Increment switch (see calibration procedure).

Operating Instructions—Type 111

- c. Trigger the Pretrigger Pulse display.
- d. Adjust the TRIG SENS ADJUST control counterclockwise just past the point where the Pretrigger Pulses stop. This is the setting for maximum trigger sensitivity, without causing the Pretrigger blocking oscillator to free run.
- e. Set the RANGE switch to 10 CPS.
- f. Check for stable triggering while varying the pulse repetition rate from 10 cps to 100 kc with the RANGE switch and REPETITION RATE control.
- g. Disconnect the signal from the oscilloscope input.

Adjust Avalanche Voltage

Satisfactory adjustment of the AVALANCHE ADJUST control can be made only with a sampling system.

1. Leave the Output Pulse display set up as described above.
2. Note the amplitude and pulse shape of the Output Pulse. If the amplitude is greater than 10 volts* (may be as high as 20 volts) and the pulse is relatively smooth with a fast rise (<500 psec), the AVALANCHE ADJUST control is probably set correctly.

NOTE

The attenuation factor of the 50-ohm T-attenuators is correct only into a 50-ohm load. If a sampling-probe system is connected as described above (with no termination), the total attenuation factor is only about 50X because of the relatively high probe impedance. Therefore, the voltage into the sampling oscilloscope will be about twice the expected value.

3. To check or set the AVALANCHE ADJUST control for optimum Output Pulse characteristics:
 - a. Turn the AVALANCHE ADJUST control fully counterclockwise.
 - b. Watch the Output Pulse display while turning the control slowly clockwise. Stop turning the control when the sampling display begins to break up (indicating erratic operation of the avalanche).
 - c. Turn the control slowly counterclockwise again until the display no longer has a tendency to break up. (This setting will probably be about 1 volt below the maximum amplitude attained before the sampling display started to break up.)

Selecting the Output Pulse Characteristics

The polarity, repetition rate and time delay of the Output Pulse may all be selected with front-panel controls and switches. In addition, the duration of the Output Pulse may be varied by changing the length of the external charge line connected at the rear panel. Amplitude of the Output Pulse is fixed at some value between 10 volts* and about 20 volts by the characteristics of the avalanche transistor and the setting of the AVALANCHE ADJUST control.

Polarity

The polarity of the Type 111 Output Pulse is determined by the setting of the front-panel OUTPUT POLARITY switch. Positive-going pulses are obtained when the switch is in the + position and negative-going pulses are obtained in the — position*.

Duration

The duration (width) of the Output Pulses is determined by the electrical length of the charge line connected to the CHARGE LINE connector. If no external charge line is used, the pulse duration is approximately 2 nsec set by the length of the internal charge line between the CHARGE LINE connector and the avalanche circuit.

When an external charge line is added, the duration of the Output Pulse is twice the transit time of the external and internal charge lines. Any coaxial cable with polyethylene dielectric (for example, RG-58A/U or RG-8A/U) will increase the pulse duration by approximately 1 nsec for each 4 inches increase in charge line length. The 9-nsec charge line supplied with the Type 111 produces an Output Pulse of approximately 20 nsec—18 nsec due to the external charge line plus 2 nsec from the internal charge line. This 20-nsec pulse is convenient for many applications.

Maximum pulse duration permissible at a repetition rate of 100 kc is 33 nsec*, produced by using 15.5 nsec of external charge line. The pulse duration may be increased at lower repetition rates, as indicated by the graph in Fig. 2-3. At 1 kc or less the pulse duration may be as long as 1.5 μ sec, produced by using 749 nsec of external charge line.

Always use high-quality 50-ohm coaxial cables for charge lines to insure the best possible characteristics of the Output Pulse (see "Cabling Considerations" later in this section of the manual). Do not terminate or short circuit the free end of the charge line. It must be left open to produce the Output Pulse.

Repetition Rate

The RANGE switch and the REPETITION RATE control on the front panel of the Type 111 set the repetition rate of both the Output Pulse and the Pretrigger Pulse. The RANGE switch selects the general range of repetition rates and the REPETITION RATE control varies the rate within that range. Front-panel markings on the RANGE switch indicate the lower end of the range selected at that position, and the REPETITION RATE control serves as a 1 to 10 multiplier. For example, at the 10 KC position of the RANGE switch, the lower end of the range is 10 kc and the pulse rate can be varied with the REPETITION RATE control from 10 kc to 100 kc. The indicated ranges are only approximate and there is a slight overlap between ranges.

*S/N 101-799:

Pulse amplitude is 5 volts or greater;

In the — position of the OUTPUT POLARITY switch, the inverting transformer introduces about 5% decrease in pulse amplitude, a slight increase in risetime and about 3% tilt on a 20-nsec pulse;

Maximum pulse duration is 20 nsec at 100-kc repetition rate, increasing to 142 nsec at 15 kc or less. Exceeding these limits may damage the avalanche transistor, Q84.

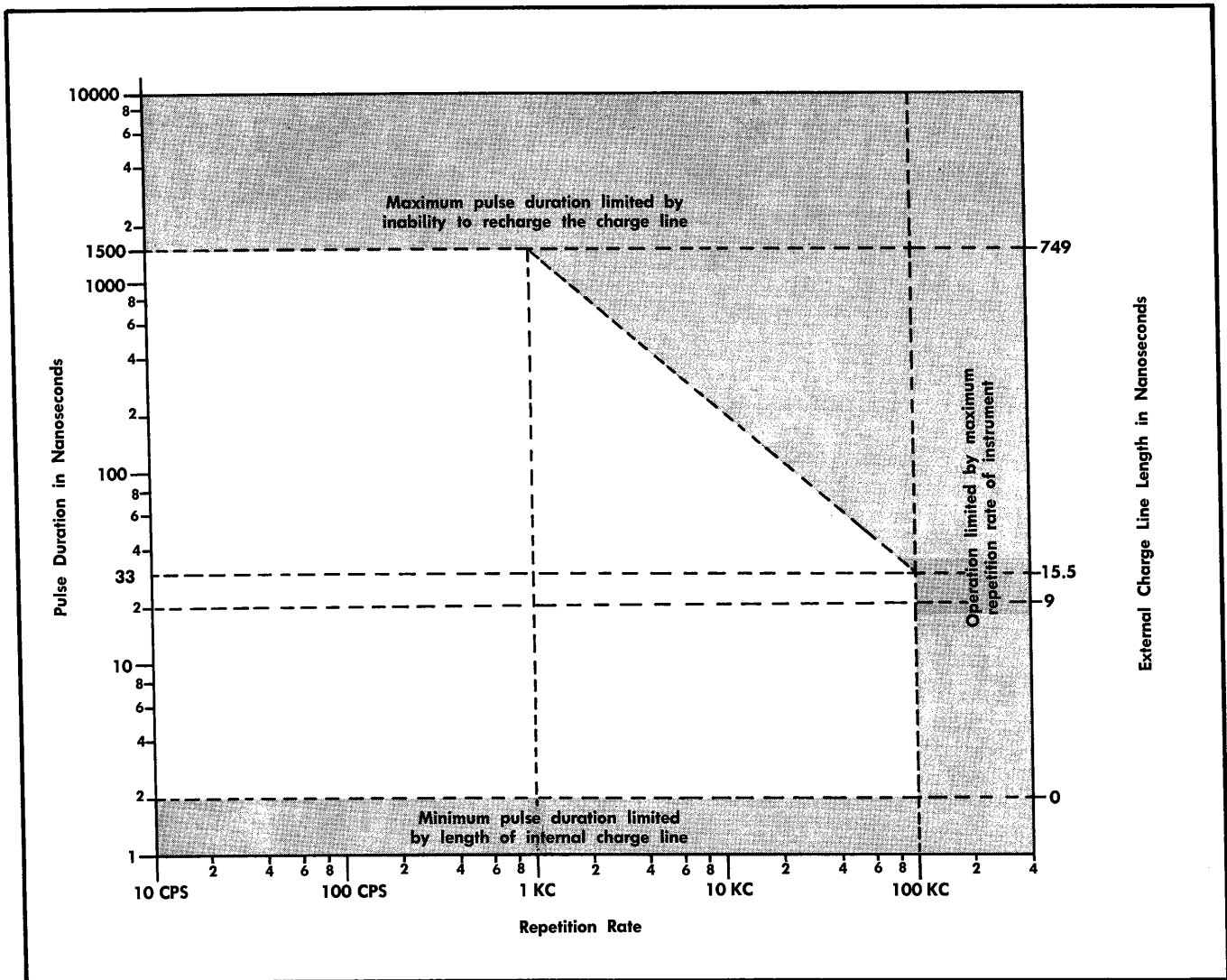

Fig. 2-3. Charge line selection guide (S/N 800-up). * White area represents normal operation. Pulse duration equals 2 nsec plus double-transit time of external charge line.

At the EXT TRIG position of the RANGE switch, the pulse repetition rate is determined by the repetition rate of the external triggering signal applied to the rear-panel EXT TRIGGER INPUT connector.

To obtain a desired pulse repetition rate from the internal Repetition Rate Generator, first select the range with the RANGE switch, then adjust the REPETITION RATE control for the approximate desired rate as estimated from the position of the REPETITION RATE control knob. For a more accurate setting of the rate, monitor the Pretrigger Pulse with a calibrated test oscilloscope while setting the REPETITION RATE control.

To use an external triggering signal for setting the repetition rate, apply a signal with the desired repetition rate (from single pulses to 100 kc) to the EXT TRIGGER INPUT connector on the rear panel. Using this method, the repetition rate can be synchronized with some external signal or can

*S/N 101-799: Output Pulse maximum duration is 20 nsec at 100-kc repetition rate, increasing to 142 nsec at 15 kc or less.

be set to a very precise rate by triggering from a time-mark generator. (See "Cabling Considerations" later in this section for connecting the external signal.)

Delay

The time delay between the Pretrigger Pulse and the Output Pulse can be varied from 30 nsec to 250 nsec with the front-panel VARIABLE (Trigger to Pulse Time Difference) delay control. By using the Pretrigger Pulse to trigger the display oscilloscope, the sweep is started before the Output Pulse is generated, and the leading edge of the Output Pulse can be viewed without requiring the use of signal delay cables.

To use the time delay, trigger the oscilloscope with the Pretrigger Pulse (using attenuators as necessary) and adjust the Type 111 VARIABLE control to position the desired portion of the waveform onto the crt screen. By moving the Output Pulse (or resulting waveform) into the "time window"

of the crt screen, the VARIABLE control produces the effect of moving the display horizontally on the screen.

Triggering From an External Source

The external triggering feature permits the use of positive-going signals such as square waves or simple pulses, with repetition rates from zero (1 pulse) to 100 kc, to be used for triggering the Type 111 (see "Repetition Rate" above). When the RANGE switch is in the EXT TRIG position, triggering signals applied to the EXT TRIGGER INPUT connector control the operation of the pulse-generating circuits. Each time a triggering pulse is received, a Pretrigger Pulse and an Output Pulse are produced.

The external triggering signal must have an amplitude between +3 volts and +50 volts and must have a rate of rise of 3 volts/ μ sec or faster (see Fig. 2-2). A 50-volt signal may have a risetime as slow as 13.3 μ sec.

If desired, the trigger sensitivity of the Type 111 can be adjusted to trigger only on external signals above a certain amplitude. This is accomplished by setting the TRIG SENS ADJUST control so the unit will just trigger (adjustment set counterclockwise as far as possible) while the signal of the desired amplitude is applied. Normally, however, the trigger adjustment is set for maximum sensitivity so that it will trigger on any external signal that falls within the requirements given above.

Use a coaxial cable or a trigger probe for connecting the external triggering signal to the Type 111. See "Cabling Considerations" later in this section for further information about connecting to the triggering signal.

Checking Sweep Rate with Fixed Increment

The FIXED INCREMENT switch provides a means of making a quick check ($\pm 10\%$) on the sweep timing in the 0.2 nsec/div to 1 nsec/div sweep range. The time shift produced by the FIXED INCREMENT switch is set by the length of a coaxial cable that is switched into and out of the Pretrigger Pulse output path.

To check the sweep timing with the FIXED INCREMENT switch:

1. Set the FIXED INCREMENT switch to 0.
2. Connect the Pretrigger Pulse to the oscilloscope external trigger input and the Output Pulse to the vertical input. Use attenuators as necessary.
3. Trigger the oscilloscope display, then use the Type 111 VARIABLE control to position the rising portion of the Output Pulse display at the centerlines of the oscilloscope graticule.
4. Set the FIXED INCREMENT switch to the +1 nSEC position and observe the time shift in the pulse rise. The shift should be 1 nsec to the left on the screen.
5. If the pulse rise does not shift 1 nsec ($\pm 10\%$) as the FIXED INCREMENT switch is moved from the 0 position to the +1 nSEC position, adjust the sweep calibration until the time shift is correct.

Though the Fixed Increment delay is specified at a tolerance of $\pm 10\%$, it can be checked to a much closer tolerance by comparing it to an accurate standard. Since the delay time is set by a fixed length of coaxial cable, it will not change appreciably over a period of time. Once the delay time produced by the FIXED INCREMENT switch has been accurately determined, sweep timing in these nsec/div ranges can be checked to almost the accuracy of the standard used for making the delay time measurement.

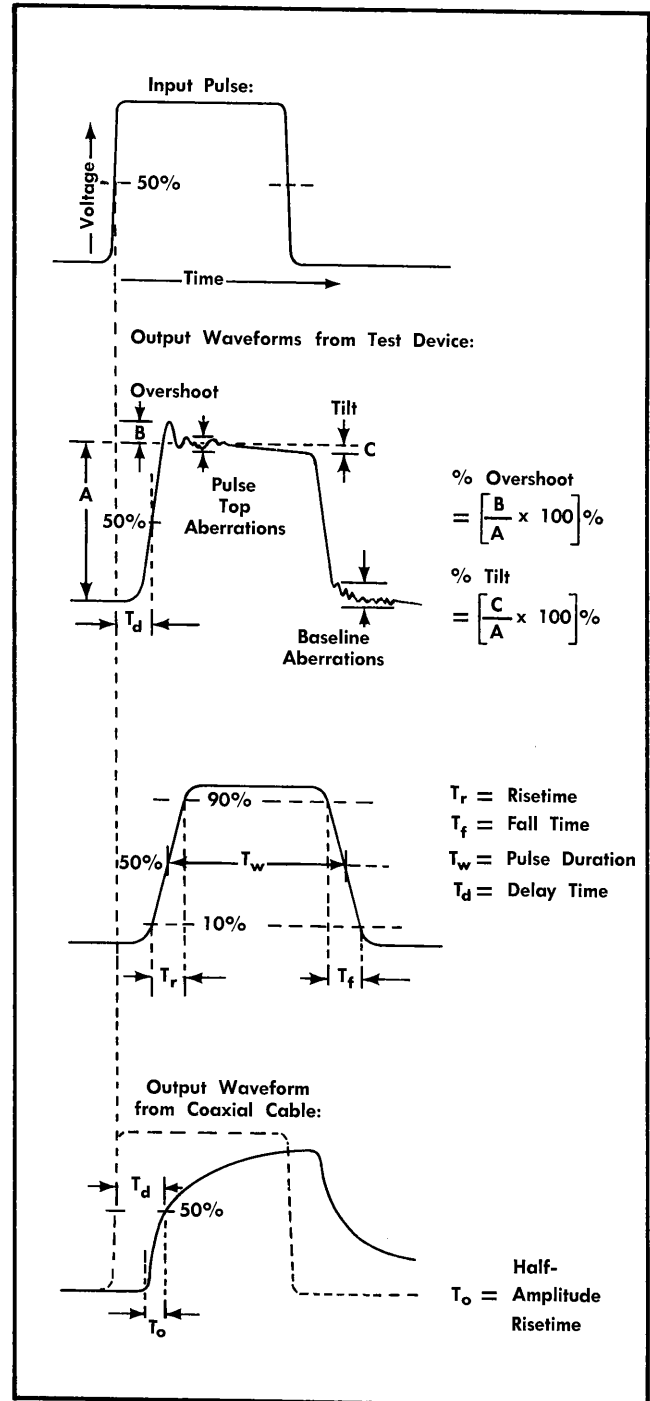

Fig. 2-4. Terms used in describing pulse characteristics.

TESTING WITH FAST-RISE PULSES

This portion of the Operating Instructions presents some of the basic concepts that must be considered when using the Type 111 for pulsing test devices. Some very general applications are included here to serve as a guide for connecting the Type 111 to other instruments in the test system. An extension of these concepts can be used for more specific applications.

Pulse Definitions

The following terms are commonly used in describing pulse characteristics. The terms are defined here and illustrated in Fig. 2-4 for your convenience. The square-wave input pulse represents an ideal fast-rise input waveform for comparison purposes.

These definitions are for guide purposes only. For very irregular pulses, some of these definitions may be meaningless.

Overshoot: The extent of pulse rise above the general level of the pulse top. The measurement is usually expressed as a percentage of the pulse amplitude.

Tilt or Droop: The amount of change in pulse amplitude between the end of the pulse rise and the start of the pulse fall. This measurement is also expressed as a percentage of the pulse amplitude, excluding overshoot.

Risetime (T_r): The time interval required for a voltage pulse to rise from the 10% level to the 90% level, relative to its peak amplitude excluding overshoot.

Falltime (T_f): The time interval required for a voltage pulse to fall from the 90% level to the 10% level, relative to its peak amplitude excluding overshoot.

Duration or Width (T_w): The time duration of the pulse measured from the 50% amplitude level on the pulse rise to the 50% amplitude level on the pulse fall.

Delay Time (T_d): The time interval between a specified level on the input pulse rise and the same level on the output pulse rise. The 50% level, shown in the illustration, is often used for this measurement. In the Type 111, Delay Time is also considered to be the time interval between the Pretrigger Pulse rise and the Output Pulse rise.

Half-Amplitude Risetime (T_o): The time interval required for an exponential output voltage to rise from the 0% level to the 50% level, relative to the amplitude of the input pulse. For a coaxial cable, T_o ("T nought") is about 1/30th as long as the 10-90% risetime (T_r).

Risetime Characteristics

When using the Output Pulse of the Type 111 to determine the risetime of a very fast test device, the risetimes of the Type 111 and the monitoring device may have to be taken into consideration. As a general rule, if the risetime of the test device is at least 10 times as long as the risetimes of the Type 111 and the monitoring oscilloscope and cables, the error introduced into the measurement by the Type 111 and the monitoring system will not be more than 1% and therefore can be considered negligible.

If, however, the risetime of the test device is less than 10 times as long as the risetimes of the Type 111 and the monitoring device, the observed risetime will be that of the system. In this case, the risetime of the test device will have to be determined from a consideration of the effects produced by the various components making up the system. Normally the overall risetime of the system can be found by taking the square root of the sum of the squares of the individual risetimes. Conversely, the risetime of the test device can be found from the same relationship if all of the system risetimes are known except that of the test device.

If there are significantly long lengths of coaxial cable in the signal path (see Fig. 2-5), the "root of the sum of the squares" method can be used only as an approximation, since the skin-effect losses in coaxial cables do not add properly with this method.

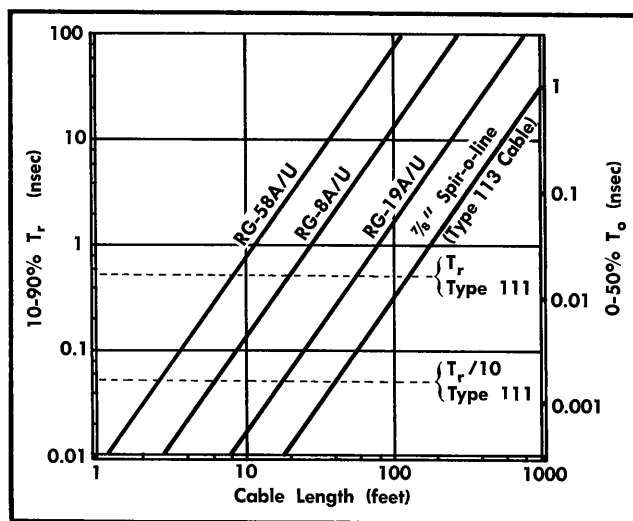

Fig. 2-5. Output signal risetime in response to a step input, given as a function of cable length for some common coaxial cables. ($T_r \approx 30T_o$.)

Basic Precautions

Certain precautions should always be observed when connecting a pulse signal to a test device and when connecting the response signal to a display device. These precautions may be summarized as follows:

1. Use the correct cables, attenuators, terminations and impedance-matching devices for the particular application. Avoid reflections on the Output Pulse by terminating the 50-ohm signal with a 50-ohm load, unless the reflections are desired for your applications. Attenuate any signals to be applied to sensitive circuits.
2. Keep ground-return paths short and direct. Use heavy conductors to provide low impedance in the ground return.
3. Make sure that all connections are tight and that all connectors are tightly assembled.
4. Use shielded equipment leads to prevent undesired coupling to other circuits. Shielding is particularly important where high-impedance circuits and dividers are involved.

Operating Instructions—Type 111

5. Consider the input characteristics of the measuring equipment to prevent loading or detuning of the test circuits and to avoid the appearance of reflections in leads and equipment.

6. Use components that function well at the frequencies and risetimes encountered. For example, use carbon deposited resistors instead of composition resistors for terminations.

7. Consider the effects of secondary parameters in components, such as inductance in resistors and in capacitor leads.

8. Consider the possible non-linear behavior of components due to voltage or temperature changes.

Cabling Considerations

The Pretrigger and Output Pulse circuits are designed to work into 50-ohm loads and to operate with a 50-ohm charge line. The short internal charge line in the Type 111 as well as all cables connecting the output circuits to the rear-panel connectors are 50-ohm coaxial cables. For best operation of the instrument, high-quality (low-loss) 50-ohm cables should also be used for external charge lines and for signal-coupling cables. The following paragraphs give additional information to be considered when connecting to each of the connectors on the rear panel.

PULSE OUTPUT. Signal cables or other devices connected to the PULSE OUTPUT connector should have a characteristic impedance of 50 ohms. Impedances other than 50 ohms will cause reflections in the signal cable that will make it difficult to interpret the resultant pulse. In addition, impedances lower than 50 ohms may load down the output circuit.

All cables that conduct the Output Pulse to the device under test should be low-loss 50-ohm coaxial cables to insure that all the information contained in the pulse will be delivered to the test point without distortion. If there is a dc voltage across the load, a coupling capacitor must be used to couple the pulse to the device. If a capacitor is not used, the output termination in the Type 111 will short the voltage to ground. Be sure the recovery time constant of the coupling is short enough (less than $2\ \mu\text{sec}$, if the full 100 kc repetition rate is to be used) to prevent distortion. If it is necessary to use cables with characteristic impedances other than 50 ohms, suitable impedance-matching devices will aid in the transition. It should be noted, however, that any such device will introduce some reflections.

Interference by reflections may be avoided by using a long 50-ohm cable between the PULSE OUTPUT connector and the device of unknown impedance. The reflections can thus be delayed (by double the transit time of the cable) until after the "time window" of interest has been observed. If this method is used, however, keep in mind the degrading effect that long lengths of delay cable (regardless of cable quality) have on the risetime of the transmitted pulse (see Fig. 2-5).

When making signal-comparison or time-difference determinations, the two signals should travel through coaxial cables that have identical loss characteristics and identical time delay.

CHARGE LINE. External charge lines used with the Type 111 must be high quality 50-ohm coaxial cables to provide Output Pulses with a minimum of aberrations on the pulse top and a minimum of reflections following the pulse. If the impedance is other than 50 ohms, the output pulse shape will be distorted. The free end of the charge line must be left open (unterminated) to allow the line to charge. (The charge line serves as the energy source for the Output Pulse.)

The duration of the Output Pulse and thus the length of the charge line must be limited as indicated in Fig. 2-3. For a repetition rate of 100 kc, the maximum length of charge line is 15.5 nsec*, producing an output pulse of 33-nsec duration. For a repetition rate of 1 kc, the charge line may be as long as 749 nsec*, producing an output pulse duration of 1.5 μsec .

PRETRIGGER OUTPUT. The impedance of the cable or other device that is connected to the PRETRIGGER OUTPUT connector should be approximately 50 ohms. An impedance below 50 ohms will load the Pretrigger Generator circuit and cause malfunction of subsequent circuitry. Impedances above 50 ohms will cause positive reflections that will increase the maximum amplitude of the Pretrigger Pulse and may cause triggering difficulties with the display oscilloscope.

Since the amplitude of the Pretrigger Pulse is approximately 10 volts (into 50 ohms), a certain amount of attenuation is usually permissible and is often necessary before the signal is applied to the oscilloscope external trigger input. Most conventional oscilloscopes will trigger best if the Pretrigger Pulse is attenuated by a factor of 10. Most sampling oscilloscopes require at least 100 times attenuation of the Pretrigger Pulse. In either of these cases, placing one or two 10X 50-ohm T-attenuators on the PRETRIGGER OUTPUT connector will provide a 50-ohm environment for the output and will reduce reflections to a negligible value, regardless of the impedance of any external cables connected to the attenuators.

Though the VARIABLE control provides a wide range of delay, it is important to keep the triggering cables as short as possible to retain the proper time relationship between the Pretrigger and Output Pulses. Any increase in trigger cable length may require an increase in signal delay cable length and result in degrading the Output Pulse risetime.

EXT TRIGGER INPUT. A shielded cable should be used for connecting external triggering signals to the Type 111, but the characteristic impedance of the cable is not important. Input impedance at the EXT TRIGGER INPUT connector is quite high (approximately 100 k and 30 pf) and varies with the setting of the REPETITION RATE control.

For many applications, a probe can be installed directly on the EXT TRIGGER INPUT connector and the probe tip connected to the desired triggering source. Use a 10X probe for triggering signals from 30 to 500 volts in amplitude or a 1X probe for signals from 3 to 50 volts in amplitude. For best results, the probe should be compensated after installation. This may be done by connecting the probe tip

*S/N 101-799: Maximum external charge line length is 9 nsec at 100-kc repetition rate, increasing to 70 nsec at 15 kc or less. For pulses exceeding 20 nsec in duration (9-nsec charge line), there will be tilt to the pulse top.

to a square-wave signal source and (with the RANGE switch set to EXT TRIG) adjusting the trigger probe compensation while monitoring the signal with a test probe just inside the EXT TRIGGER INPUT connector.

Coaxial Cables. The characteristic impedance, velocity of propagation and nature of signal losses in a coaxial cable are determined by the physical and electrical characteristics of the cable. Signal losses caused by energy dissipation in the dielectric are proportional to the signal frequency. Therefore much of the high-frequency information in a fast-rising pulse can be lost in a very few feet of interconnecting cable.

Fig. 2-5 shows the relative increase in output signal risetime as a step input signal is passed through several types of commonly used 50-ohm coaxial cables. This increase in output risetime must be taken into consideration when making risetime determinations. For example, a length of cable with a 225-psec output risetime will degrade the Type 111 Output Pulse by about 10%. (This may be determined by the "root of the sum of the squares" formula.) As can be seen from the graph, it takes only about 6 feet (9 nsec) of RG-58A/U cable to cause this 10% change. However, it will take about 15 feet (22.5 nsec) of RG-8A/U or 80 feet (95 nsec) of Spir-o-line to cause the same amount of change. If signal delay greater than 60 nsec is required, the use of a Tektronix Type 113 Delay Cable is recommended.

It is important to note that the risetime of the transmitted signal deteriorates approximately in proportion to the square of the length of the cable. As an illustration, the risetime of the Type 111 Output Pulse would be increased to 1000 psec (100% increase) by a length of cable with a risetime of about 867 psec. From Fig. 2-5 it is seen that approximately 10 feet (15 nsec) of RG-58A/U, 25 feet (37.5 nsec) of RG-8A/U or 115 feet (137 nsec) of Spir-o-line would cause this amount of risetime change. Comparing this result with the previous determination, it is seen that a 67% increase in cable length would produce a 900% increase in risetime deterioration.

Impedance Matching

To provide a smooth transition between devices of different characteristic impedance, each device must encounter a total impedance equal to its own characteristic impedance. A certain amount of signal attenuation is usually required to achieve this transition. A simple resistive impedance-matching network that provides minimum attenuation is illustrated in Fig. 2-6.

To match impedances with the illustrated network, the following conditions must exist:

$$\frac{(R_1 + Z_2) R_2}{(R_1 + Z_2) + R_2} \text{ must equal } Z_1; \text{ and } R_1 + \frac{Z_1 R_2}{Z_1 + R_2} \text{ must equal } Z_2.$$

Therefore:

$$R_1 R_2 = Z_1 Z_2; \text{ and } R_1 Z_1 = R_2 (Z_2 - Z_1)$$

$$\text{or } R_1 = \sqrt{Z_2 (Z_2 - Z_1)}$$

$$\text{and } R_2 = Z_1 \sqrt{\frac{Z_2}{Z_2 - Z_1}}$$

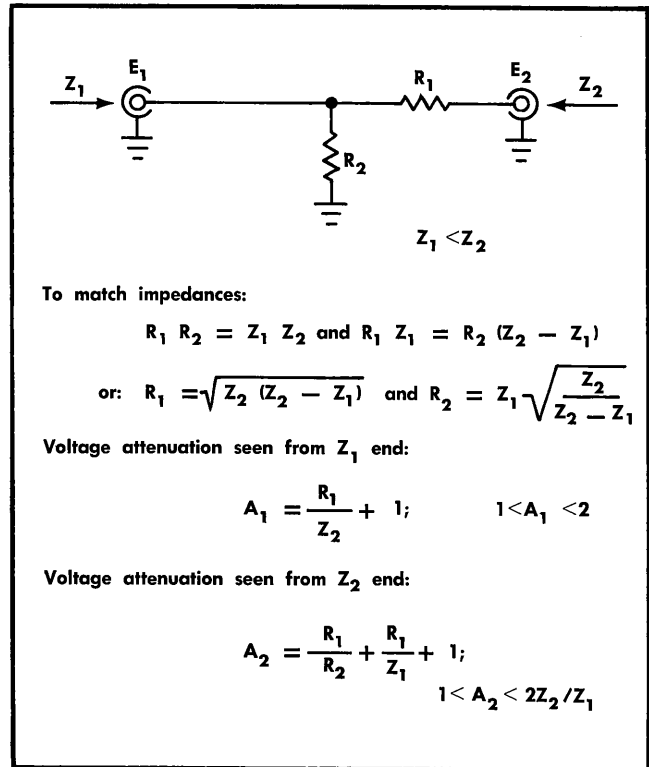

Fig. 2-6. Simple resistive impedance-matching network providing minimum attenuation.

As an example, to match a 50-ohm system to a 125-ohm system:

$$Z_1 = 50 \text{ ohms; and } Z_2 = 125 \text{ ohms.}$$

Therefore:

$$R_1 = \sqrt{125 (125 - 50)} = 96.8 \text{ ohms}$$

$$\text{and } R_2 = 50 \sqrt{\frac{125}{125 - 50}} = 64.6 \text{ ohms}$$

When constructing such a device, the environment surrounding the components should also be designed to provide a transition between the impedances. Keep in mind that the characteristic impedance in a coaxial system is determined by the ratio between the outside diameter of the inner conductor and the inside diameter of the outer conductor ($Z_0 = 138 \log_{10} D_1/D_2$).

Though the network in Fig. 2-6 provides minimum attenuation for a purely resistive impedance-matching device, the attenuation as seen from one end does not equal that seen from the other end. A signal applied from the lower impedance source (Z_1) encounters a voltage attenuation (A_1) that may be determined as follows:

$$\text{Since: } i_{R_1} = i_{Z_2}; \frac{E_1 - E_2}{R_1} = \frac{E_2}{Z_2}$$

$$\text{Therefore: } A_1 = \frac{E_1}{E_2} = \frac{R_1}{Z_2} + 1; (1 < A_1 < 2)$$

A_1 is between 1-time and 2-times attenuation.

Operating Instructions—Type 111

A signal applied from the higher impedance source (Z_2) will encounter a greater voltage attenuation (A_2) that may be determined similarly:

$$\text{Since: } i_{R_1} = i_{R_2} + i_{Z_1}; \frac{E_2 - E_1}{R_1} = \frac{E_1}{R_2} + \frac{E_1}{Z_1}$$

$$\text{Therefore: } A_2 = \frac{E_2}{E_1} = \frac{R_1}{R_2} + \frac{R_1}{Z_1} + 1; (1 < A_2 < \frac{2Z_2}{Z_1})$$

In the example of matching 50 ohms to 125 ohms,

$$A_1 = \frac{96.8}{125} + 1 = 1.77;$$

$$\text{and } A_2 = \frac{96.8}{64.6} + \frac{96.8}{50} + 1 = 4.44$$

Note that if the Type 111 were used for pulsing a high-impedance load, R_1 would approximately equal the impedance of the load (high R) and R_2 would approximately equal the 50 ohms of the Type 111 output. In this situation, voltage attenuation would be about 2.

If a low-impedance load (<50 ohms) were to be pulsed, the Output Pulse from the Type 111 would be the Z_2 source. If the load impedance were to approach 0 ohms, the value of R_1 would then approach 50 ohms and R_2 would approach the load impedance (high R). Voltage attenuation in this case would become quite significant:

$$\text{Attenuation} = \frac{2Z_2}{Z_L} = \frac{100}{Z_L} \text{ (very high)}$$

The illustrated network can be modified to provide different attenuation ratios by adding another resistor (< R_1) in series between Z_1 and the junction of R_1 and R_2 .

Impedance Measurement

As a signal travels down a transmission line, each time it encounters a mismatch, or different impedance, a reflection is generated and sent back along the line to the source. The amplitude and polarity of the reflection are determined by the value of the encountered impedance in relation to the characteristic impedance of the cable. If the mismatch impedance is higher than that of the line, the reflection will be of the same polarity as the applied signal; if it is lower than that of the line, the reflection will be of opposite polarity.

The reflected signal is added to or subtracted from the amplitude of the pulse if it returns to the source before the pulse has ended. Thus, for a cable with an open end (no termination), the impedance is infinite and the pulse amplitude would be doubled. For a cable with a shorted end, the impedance is zero and the pulse would be canceled.

Measurement of an encountered impedance can be made either by observing the change in amplitude of the applied pulse or by measuring the reflection alone after separating the reflection from the pulse with delay cables. The amplitude of the reflection (ρ), expressed as a decimal fraction of the applied pulse amplitude, is related to the characteristic impedance of the system (Z_0) and to the load impedance (Z_L) in the following manner:

$$\rho = \frac{Z_L - Z_0}{Z_L + Z_0}; \text{ Therefore: } Z_L = Z_0 \left(\frac{1 + \rho}{1 - \rho} \right)$$

The load impedance can thus be calculated from the amplitude of the reflection. For example, consider the following situation: A 20-volt pulse is sent down a 50-ohm cable and encounters an unknown impedance; the reflection returns to the pulse source before the pulse has ended and the resulting amplitude is 25 volts. The reflection amplitude is therefore +5 volts, and $\rho = +5/20 = +0.25$.

$$\text{Therefore: } Z_L = 50 \left(\frac{1.00 + 0.25}{1.00 - 0.25} \right) = 83.3 \text{ ohms}$$

Operation With a Sampling System

One of the primary applications of the Type 111 Pretrigger Pulse Generator is in testing with sampling-type oscilloscopes. In the usual application, the Pretrigger Pulse from the Type 111 triggers the sweep and sampling circuits of the oscilloscope, while the Output Pulse from the Type 111 is applied to some test device. The output signal from the test device is then connected to the oscilloscope vertical input where the waveform is monitored. Fig. 2-7 shows the connections between the Type 111 and the other equipment. Use a 50-ohm coaxial cable and suitable impedance matching device for connecting the Type 111 Output Pulse to the device under test.

When all connections have been made, free run the trace to position the display baseline, then trigger the oscilloscope display on the positive Pretrigger Pulse. (The pulse waveform of the test device signal may be off-screen.) Center the oscilloscope Delay (Time Position) control and use the Type 111 VARIABLE delay control to position the waveform on the crt screen. The display moves in the direction the knob is turned—to the right when the knob is turned clockwise and to the left when it is turned counterclockwise.

If it is not possible to display the desired portion of the waveform on the oscilloscope screen, it will be necessary to change the interconnecting cable lengths for the proper delay. Keep all cables as short as possible to avoid deterioration of the pulse risetime.

Operation With a Conventional Oscilloscope

Use of the Type 111 with a conventional oscilloscope is similar to its use with a sampling system. The conventional oscilloscope test system may be used whenever the frequency response of the test device falls within the band-pass limitations of the oscilloscope vertical amplifier. Fig. 2-8 shows the connections required. A 10X triggering probe may be substituted for the external trigger cable and attenuator shown in the illustration.

Trigger the oscilloscope display on the positive Pretrigger Pulse and position the display with the Type 111 VARIABLE control.

In some cases it may be desirable to use internal triggering of the sweep, but usually external triggering is preferred to assure that the oscilloscope sweep is started before the signal arrives from the test device. The external trigger also provides a constant triggering signal that

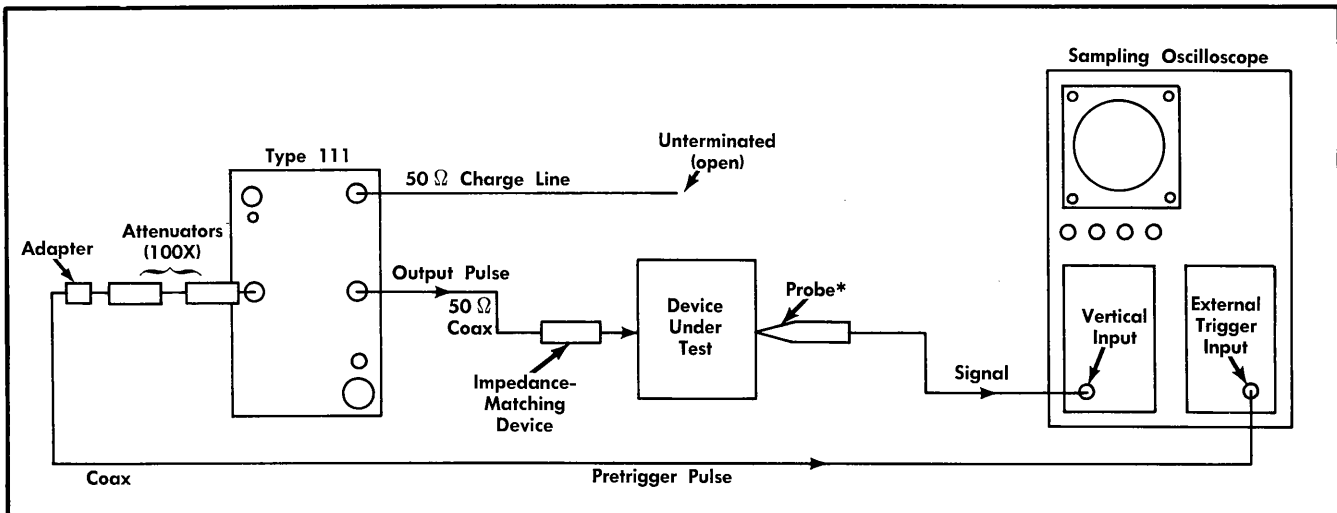

Fig. 2-7. Test setup where the Type 111 is used in conjunction with a sampling oscilloscope. *Sampling probe or other signal takeoff device. (Be sure to use sufficient attenuation of vertical input signal.)

eliminates readjustment of the triggering controls and permits time-relationship measurements to be made between signals at various points in the test device.

illustrated in Fig. 2-10. A convenient method of connecting to the deflection-plate pins is to use clips removed from a standard miniature tube socket.

Direct Connections to Deflection Plates

Faster risetime pulses can sometimes be observed on a conventional oscilloscope by connecting directly through coupling capacitors to the vertical deflection plates. Fig. 2-9 shows the connections of the test system. The band-pass limitations of the vertical amplifier are bypassed and the oscilloscope risetime is then limited only by the transit time of the electron beam between the vertical deflection plates and by the resonant frequency (f_0) of the connecting network.

CAUTION

Do not allow the output leads from the oscilloscope vertical amplifier to come in contact with the chassis or tube shield while the power is on. A short circuit can damage the amplifier circuits.

The values of R_1 and R_2 are found by solving the equation given in the illustration. The resonant frequency (f_0) of the leads and the capacitance of the deflection plates (C_d) for use in the equation may be determined by the following procedure:

An ac-coupling circuit that allows the oscilloscope to provide the normal positioning and operating voltages is

1. Turn off the oscilloscope power.

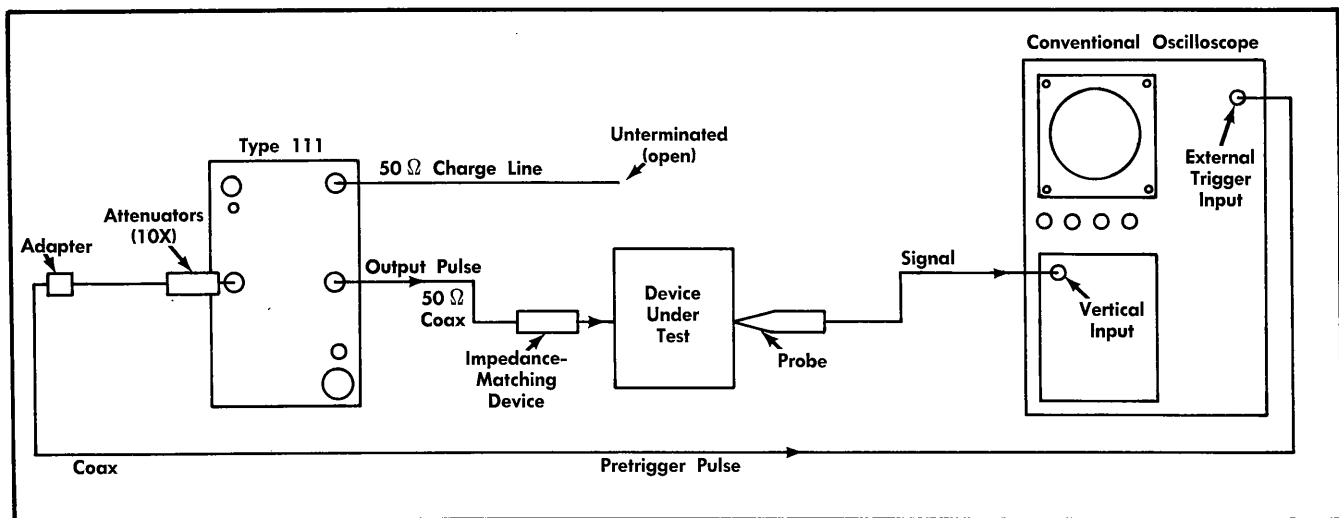

Fig. 2-8. Test setup where the Type 111 is used in conjunction with a conventional oscilloscope.

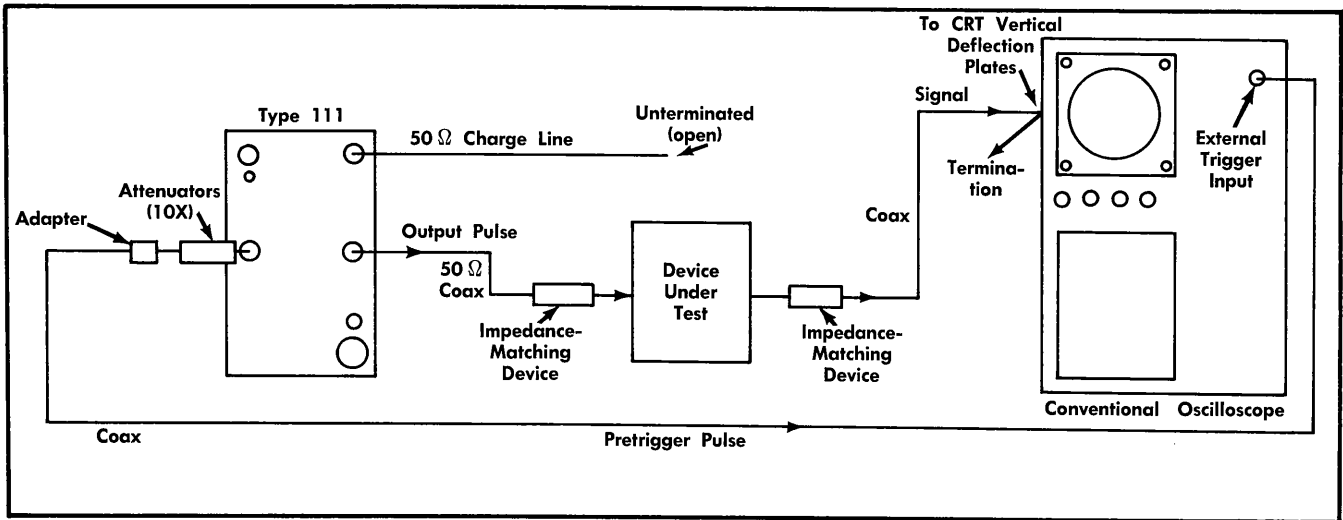

Fig. 2-9. Test setup where the signal is coupled directly to the vertical deflection plates.

2. Disconnect the vertical amplifier leads from the crt neck pins.
3. Cut a wire loop equal in length to the total length of C_1 , C_2 , R_1 , R_2 , R_3 and R_4 .
4. Temporarily substitute the wire loop for the components between the vertical deflection plate pins.
5. Bring a grid-dip meter near the loop and measure the resonant frequency (f_0).
6. Remove the wire loop.
7. With a capacitance meter, measure the total capacitance between the plates (C_d) at the deflection plate neck

pins. (Capacitance between the plates can also be found by referring to the electrical specifications of the crt type.)

Since the deflection plates are located close to the path of the electron beam, a small amount of current will flow in the deflection plate circuits. The values of R_3 and R_4 must be low enough that this current will not produce a large voltage drop at the deflection plates. If the resistors are too large, distortion, defocusing or positioning difficulties may be experienced. Since the deflection-plate current varies non-linearly with the position of the beam, the effects are most noticeable when the beam is positioned near the top or the bottom of the screen. The approximate value of 100 k that is given for R_3 and R_4 in Fig. 2-10 will probably be satisfactory in most cases.

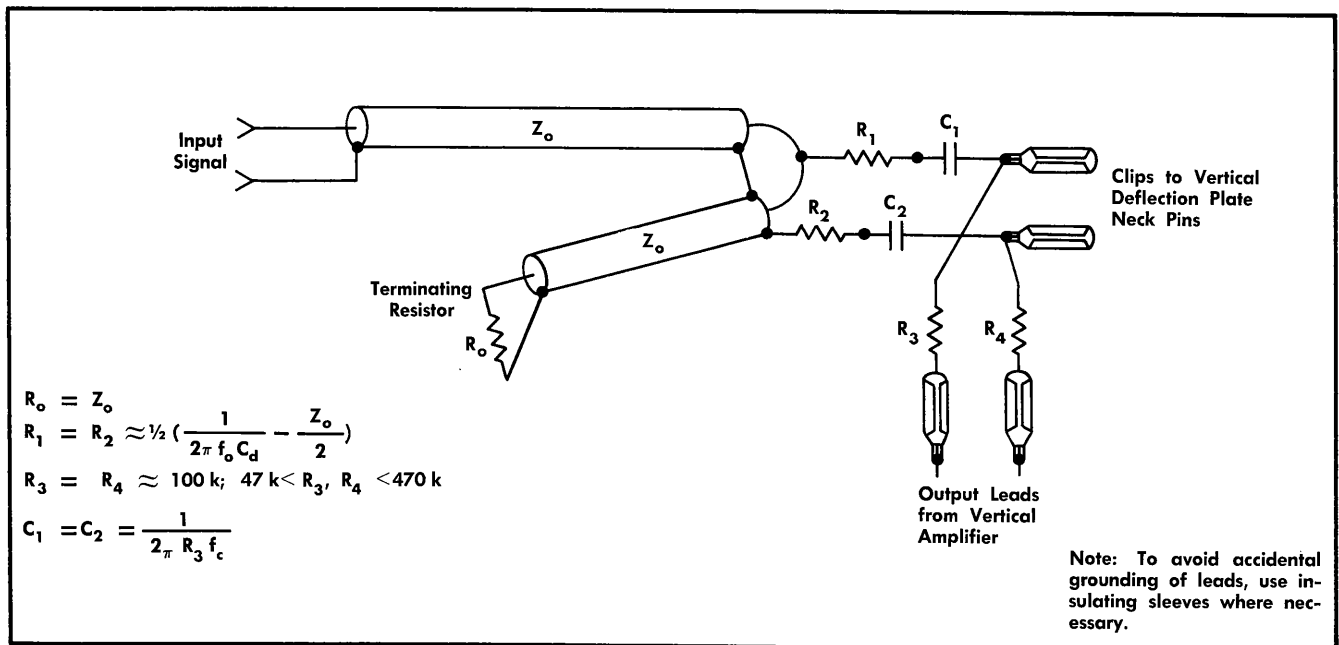

Fig. 2-10. Circuit for ac-coupling directly to crt vertical deflection plates.

C_1 and C_2 should be small in physical size to minimize lead inductance. The values of C_1 and C_2 are selected on the basis of the required low-frequency response and may be calculated from the second equation in Fig. 2-10 (f_c is the low-frequency cutoff). For example, if R_3 and R_4 are 100 k and if the desired f_c is about 1.6 kc, C_1 and C_2 should be .001 μ f.

The stub cable that connects to terminating resistor R_0 should be long enough that if a double-transit reflection appears, it can be easily identified and corrected by adjustment of the termination.

For making vertical measurements with this test setup, the deflection factor of the crt will need to be known. This can be measured as follows:

1. While the leads from the vertical amplifier are connected to the deflection-plate neck pins, connect a dc voltmeter between the pins.
2. Measure the voltage change as the beam is positioned vertically over the full height of the graticule.
3. Divide this voltage excursion by the graticule height in divisions to obtain the deflection factor in volts/division.

SECTION 3

CIRCUIT DESCRIPTION

Block Diagram

The Type 111 Pretrigger Pulse Generator consists of five stages and a power supply. The functional relationships between the five signal-generating stages are shown on the fold-out Block Diagram at the rear of this manual.

The Repetition Rate Generator circuit (V15) is an astable multivibrator that sets the repetition rate of the Output and Pretrigger Pulses. Operation of the circuit is controlled by the RANGE switch and the REPETITION RATE control. The output of this multivibrator is applied to the Pretrigger Generator (Q40).

Each time a triggering pulse is received from the Repetition Rate Generator, the Pretrigger blocking oscillator conducts to produce a pulse output. The resulting pulse is applied to both the PRETRIGGER OUTPUT connector and to a constant-current charging network, the Ramp Generator.

When the clamp diode (D64) is turned off by the Pretrigger blocking oscillator pulse, the Ramp Generator begins its voltage runup. The ramp continues rising until the Comparator (Q60) turns on. The time from the start of the ramp until the Comparator blocking oscillator conducts is varied by changing the comparison voltage at the base of Q60 with the VARIABLE control. The Comparator output pulse is then applied to the Output Pulse Generator (Q84).

Each Comparator pulse causes the output transistor to avalanche, discharging the charge line and delivering an Output Pulse to the PULSE OUTPUT connector. The avalanche continues until the charge line is completely discharged, which takes approximately twice the transit time of the charge line. The Output Pulse duration is therefore also approximately twice the transit time of the charge line.

The delay time between the Pretrigger and the Output Pulse may be decreased by an increment of 1 nsec by passing the Pretrigger Pulse through a 1-nsec delay cable operated by the front-panel FIXED INCREMENT switch. The positive Output Pulse may also be inverted by switching it through an inverting transformer with the OUTPUT POLARITY switch.

Power Supply

Ac power for the instrument is applied through a line filter network to the primary windings of T601. The primary windings are connected in parallel for 117-volt operation and in series for 234-volt operation (see schematic diagram). One of the secondary windings of T601 is used to supply filament power for V15 and to light the pilot lamp when the transformer is operating. The other secondary winding supplies approximately 340 volts rms to a full-wave bridge rectifier circuit consisting of D612A, B, C and D. The output of the bridge rectifier circuit is then applied to an RC filter network. Resistors R614 and R615

set the current through V619 at a value that permits the tube to regulate, and the voltage across V619 is maintained at 150 volts by the regulator action.

A voltage divider across V619 provides operating voltages for the instrument, including the charge line voltage. The AVALANCHE ADJUST control, R622, adjusts the collector voltage of the Output Generator to a point just short of where the transistor avalanches. Zener diodes D624 and D625 maintain regulated outputs of +6 and -15 volts, respectively.

Repetition Rate Generator

Whenever power is applied to the Type 111 and the RANGE switch is set at any position other than EXT TRIG, the Repetition Rate Generator stage free runs. The frequency of the astable multivibrator operation depends on the time required for the coupling capacitors to discharge sufficiently to permit the non-conducting section to conduct. The discharge time of the circuit is determined largely by the values of C12, C16 and R14. By changing the values of either the capacitors or the resistors, the time constant of the circuit, and hence the multivibrator frequency, can be changed. The RANGE switch selects the appropriate values of C12 and C16 while the REPETITION RATE control adjusts the values of R14. The two controls in conjunction provide a continuously variable multivibrator repetition rate from 10 cps to approximately 100 kc. Simultaneous selection of C12 and C16 maintains symmetry of the multivibrator output as the RANGE switch is turned. Similarly, the dual control of R14 maintains symmetry when the REPETITION RATE control is rotated.

When the RANGE switch is in the EXT TRIG position, V15A is disabled and V15B is used as an external trigger isolation amplifier for signals applied to the EXT TRIG INPUT connector. The external triggering signal is coupled through C12A to the grid of V15B. The amplified signal at the plate of V15B is then applied to the Pretrigger Generator. In this case, the repetition rate is controlled by the repetition rate of the external triggering signal, up to the recovery time of the Pretrigger Generator (approximately 10 μ sec or 100 kc).

Pretrigger Generator

The output of the Repetition Rate Generator is applied to the collector of Q40 through C21, T21 and D23. Capacitor C21 and the load reflected back into the primary of T21 differentiate the multivibrator waveform. Positive pulses at the junction of C21 and T21 are suppressed by D21. The negative pulses are inverted by T21 (an impedance-matching transformer) and applied through D23 as positive triggers to the collector of Q40. After being reinverted by T40, the pulses are also applied to the base of Q40 as negative triggers.

Normally the base voltage of Q40 is set by the adjustment of the TRIG SENS ADJUST control, R33. This setting is made so that the base of Q40 is held slightly positive with

Circuit Description—Type 111

respect to the emitter, thereby holding the transistor in cutoff. When a negative signal is applied to the base, the transistor begins to conduct. Current flow through the transistor causes the collector voltage of Q40 to go further positive, inducing a greater negative voltage at the base. This regenerative action continues until the transistor tends to saturate. When this occurs, emitter current is determined primarily by the charge on C44 and the load reflected into the collector circuit from the output windings of T40.

As current through the inductance of T40 increases, the transformer is driven toward saturation. As the transformer saturates, the induced negative voltage drive to the base of Q40 decreases. During the conduction period of Q40, the base current charges C36 in a positive direction. When the induced base drive voltage becomes insufficient to overcome the positive charge on C36, the transistor cuts off. Circuit values have been chosen so the output of the blocking oscillator is a positive gate approximately 10 volts in amplitude and over 240 nanoseconds in duration.

At the end of the Pretrigger Pulse, the charge on C36 holds the base of Q40 sufficiently positive to prevent additional triggering signals from causing the transistor to conduct again immediately. The positive voltage on C36 also reverse biases D33, and C36 discharges through R36. When C36 has discharged partially, triggering signals applied to the Pretrigger blocking oscillator are again capable of causing the circuit to operate. The time constant of C36 and R36 has been chosen to limit the maximum operating rate of the blocking oscillator to slightly over 100 kc.

One of the output windings of T40 couples the output gate of the blocking oscillator to the Ramp Generator circuit. The other output winding couples the gate to the PRETRIGGER OUTPUT connector on the rear panel. When the FIXED INCREMENT switch is in the +1 nsec position, the gate is delayed an additional 1 nanosecond by means of a short length of coaxial cable. This 1-nanosecond time shift of the Pretrigger Pulse enables the sweep timing of an oscilloscope to be checked by the time-shift method.

Ramp Generator

Energy stored in the field of T40, at the end of the output pulse from the Pretrigger blocking oscillator, is returned to the circuit in the form of a back swing. Diodes D62 and D63 limit this back swing to a negligible amount. Diode D62 blocks any negative signals from the output of T40 while D63 prevents the junction of D63 and D64 from going negative.

When Q40 is cut off, approximately 5 ma flows from ground through R62, D64, R66 and R64 to the +135-volt supply. This causes the junction of R66 and D64 to be at approximately -1 volt, thereby charging both C67 and C68 to this voltage. When a pulse is generated by Q40, the positive signal voltage cuts off D64. Capacitors C67 and C68 then charge toward +115 volts (the potential on C64). The initial charging current of approximately 5 ma must also flow through R67 and R68. The current flowing through the resistors, in addition to the pulse coupled through D64 (due to its finite recovery time), produces an immediate step of approximately 200 millivolts at the emitter of Q60. The voltage step is followed by an exponential voltage rise due to the continued charging of C67 and C68. Since only a short

portion of the exponential rise is used, the voltage rise is nearly linear. The positive step followed by the approximately linear voltage rise forms the ramp voltage that is applied to the emitter of Q60. The small step is used to bring the emitter voltage sharply positive to assure that Q60 can be safely triggered from cut off. Thus Q60 can be turned on near the beginning of the ramp when minimum delay is desired.

Comparator

The base voltage of Q60 is controlled by the setting of R51 (MAX DELAY), R53 (VARIABLE) and R54 (MIN DELAY). These controls form a voltage divider between +6 volts and ground. The setting of these controls determines the amount of time delay occurring before generation of the output pulse from the Comparator blocking oscillator. At some point on the ramp the emitter voltage of Q60 begins to go positive with respect to the base voltage. When this occurs, Q60 conducts to generate an output pulse. MIN DELAY and MAX DELAY adjustments are set to limit the operating range of the VARIABLE control.

Operation of the Comparator blocking oscillator is similar to that of the Pretrigger blocking oscillator.

Output Pulse Generator (S/N 800-Up)

The positive output pulse from the Comparator blocking oscillator is applied to the Output Pulse Generator (avalanche stage) through C75 and D80. Since the collector voltage of Q84 is set just short of the point where the transistor will avalanche, when the voltage pulse from T60 turns on D80, a fast current pulse is applied to the base of Q84, causing the transistor to avalanche. This allows the internal charge line (and the external charge line, if any) to begin to discharge. The resulting positive voltage step at the emitter of Q84 produces the start of the output pulse.

As Q84 avalanches, the negative pulse at the collector travels down the charge line and is reflected, in phase, from the open end. When the reflected pulse reaches the collector of Q84, the collector voltage drops still further, causing the transistor to stop avalanching. This ends the output pulse at the emitter. The negative pulse that turns off Q84 is also applied through a low impedance path (D86, C88 and R89) to the output circuit, speeding the fall of the output pulse. Diode D87 in the emitter circuit of Q84 stops the falling edge of the pulse at ground level.

During formation of the output pulse, the charge line effectively acts as the energy source. The duration of the pulse is determined by the electrical length of the charge line. Since the pulse at the collector of Q84 has to travel down the charge line and then return, the duration of the pulse is equal to the double-transit time of the line. The impedance of the charge line is 50 ohms and consequently, to prevent multiple reflections in the line, the transistor end of the charge line must be terminated in 50 ohms. Since D86 is conducting after the reflected pulse arrives at the collector, the line is terminated in the proper impedance by R89 in parallel with the impedance seen through Q84. Capacitor C77 compensates the high-frequency portion of the pulse rise and is adjusted for best risetime and front corner of the output pulse. Resistor R87 is selected so that its impedance,

together with the impedance in the emitter circuit of Q84 will terminate the output in 50 ohms. Resistor R85 is selected for the least possible tilt of the pulse top.

Output Pulse Generator (S/N 101-799 Only)

The positive output pulse from the Comparator blocking oscillator is applied to the Output Pulse Generator (avalanche stage) through two paths.

One path is through C75 and R75 to the collector of Q84. The pulse which takes this path is a current pulse and is most effective when short time duration charge lines are used. The collector voltage of Q84 is set just short of the point where the transistor will avalanche. Consequently, when the positive pulse from Q60 is applied to the collector of Q84, the signal is sufficient to cause Q84 to avalanche.

The second path, from T60 through C76 to the outer conductor of the internal charge line and to R77 and R78, couples a positive voltage pulse to the collector of Q84. This pulse is more effective than the current pulse in causing Q84 to avalanche when long charge lines are used. The internal charge line is passed through a ferrite toroid core (T78) to prevent the voltage pulse from being shorted to ground. The toroid core effectively isolates one end of the internal charge line.

When the pulse causes Q84 to avalanche, the internal charge line (and the external charge line, if any) is dis-

charged. A negative pulse travels down the charge line and is reflected, in phase, from the open end. When the reflected pulse reaches the collector of Q84, the collector voltage drops sufficiently for the transistor to stop avalanching. This ends the output pulse. During formation of the output pulse, the charge line effectively acts as the energy source. The impedance of the charge line is 50 ohms and consequently, to prevent multiple reflections in the line, the Q84 end of the charge line must be terminated in 50 ohms. Resistor R87 in the emitter circuit of Q84 is selected so that a proper termination is presented to the charge line. Capacitor C87 in the emitter circuit controls the amount of pulse tilt. Variable capacitor C77 compensates the high-frequency portion of the pulse and is adjusted for optimum risetime and front corner of the output pulse.

Inverting Transformer

The output pulse from the emitter of Q84 may be applied to the PULSE OUTPUT connector either directly or through a pulse inverting transformer. The polarity of the output pulse is determined by the setting of the OUTPUT POLARITY switch.

Since the inverting transformer delays the output signal a small amount, a short length of delay cable is also switched into the signal path when the switch is in the + position. This short cable provides approximately the same delay as the inverting transformer, insuring that the signal delay is the same in both positions of the OUTPUT POLARITY switch.

SECTION 4

MAINTENANCE

PREVENTIVE MAINTENANCE

Periodic Inspection and Recalibration

The Type 111 should be serviced and recalibrated after each 500 hours of operation, or if used only occasionally, at least once every 6 months. Servicing and troubleshooting suggestions are given in this section. A complete calibration procedure is provided in the Calibration section of this manual.

Whenever the instrument is repaired or recalibrated, a visual check should be made of the controls and circuitry. Certain types of potential trouble can be detected by a visual inspection of the instrument. Look for such obvious defects as control knobs out of alignment, damaged connectors, loose or broken solder connections, improperly seated tubes or transistors, frayed cable shields or scorched parts. Most of these troubles can be corrected by obvious means. In the case of heat-damaged parts, however, the damage is often the result of less apparent trouble. To prevent further damage, the cause of overheating should be located and corrected before attempting to operate the instrument.

We advise against routine replacement of tubes or transistors during periodic servicing. Since each tube or transistor has its own operating characteristics, any circuit that has one of these components replaced will require a calibration check.

Removal of Panels

The side panels of the Type 111 can be easily removed for access to the internal circuitry. Each panel is held in place by screwhead fasteners that can be released with a broad-blade screwdriver or a small coin. Turn each fastener about two turns counterclockwise to free the panel. For normal operation, the panels should be left on the instrument to keep out dust.

Cleaning the Instrument

CAUTION

Do not clean any plastic materials with organic chemical solvents such as benzene, acetone or denatured alcohol. These solvents might damage the plastics.

Dirt can be removed from the cabinet exterior with a soft cloth dampened with a water solution of soap or detergent. Abrasive cleaners should not be used. A dry paint brush may be useful for removing dust from front-panel control knobs.

Normal air circulation brings a small amount of dust into the interior of the instrument. This dust should be blown out with a low-velocity stream of compressed air during periodic servicing. (Avoid the use of a high-velocity air stream that might damage small components.) Any remain-

ing dust or dirt can be removed with a damp cloth or a cotton-tipped applicator dampened with isopropanol.

CORRECTIVE MAINTENANCE

Ordering Replacement Parts

Replacements for all parts used in the Type 111 can be purchased directly through Tektronix. Many of the electrical parts can also be obtained locally, but some of the critical electrical parts and most mechanical parts can be obtained only through Tektronix. Consult the Parts List in this manual for the required characteristics before ordering or purchasing any replacement part. Instructions are given on page 6-1 for ordering parts through your local Tektronix Field Office.

Replacement Procedures

In general, the replacement of most parts in the Type 111 is simple and straightforward. However, certain precautions should be observed whenever repairs are to be made. The following paragraphs contain supplementary information that may aid you when performing corrective maintenance on the instrument.

To preserve the peak performance of the Type 111, be sure to install all replacement components in exactly the same positions as those of the original parts.

Replacement of Rotary Switches

If a rotary switch is to be removed, tag the leads and switch contacts with corresponding identification tags, then use the old switch as a model for installing the new one. The entire switch should be replaced if one section is defective. Order the switch either with or without associated components wired in place. The appropriate part numbers are given in the Parts List.

When soldering to a rotary switch, do not let the solder flow beyond the rivet on the switch terminal. The spring tension of the switch contact will be destroyed by excess solder.

Replacement of Power Transformer

If a complete check of the instrument shows that the power transformer requires replacement, notify your local Tektronix Field Office for a warranty replacement. (See the Warranty note in the front of this manual.)

Be sure to use only the correct replacement transformer. Tag the leads with the terminal numbers as they are unsoldered to aid in connecting the new transformer.

Soldering to Etched-Wiring Boards

In the assembly of Tektronix instruments, components are soldered to etched-wiring boards with ordinary electronic

Maintenance—Type 111

grade 60/40 solder, using a 25-watt chisel-tip soldering iron. A higher-wattage soldering iron applied for too long a time will cause separation of the etched wiring from the base material. If normal care is exercised, one connection may be resoldered up to 20 times.

To replace a component mounted on the etched-wiring board:

1. Cut each lead near the body of the component to free it for individual unsoldering.
2. Grip the lead with a pair of needle-nosed pliers.
3. Apply the tinned tip of a 25-watt soldering iron to the lead, between the pliers and the board, and pull gently. When the solder first begins to melt, the lead will come out, leaving a clean hole. If the hole is not clean, use a scribe or pointed tool and the soldering iron to open the terminal hole.
4. Bend the leads of the new component to the correct shape and carefully insert them into the holes.
5. Apply the soldering iron for a short time at each connection on the side of the board opposite the component to seat the component properly.
6. Apply the iron and a little solder to each connection to finish the solder joint.
7. Clip off any excess lead length that extends beyond the solder fillet.

TROUBLESHOOTING

If apparent trouble develops in the Type 111, first check the setting of front-panel controls and check all triggering and signal cables. Often an apparent malfunction is the result of incorrect control settings or incorrect operating procedures. Review the Operating Instructions section if you are not familiar with the operation of the Type 111.

After checking control settings and connecting cables, if operation of the instrument is still incorrect, the following outline may be used as a guide for locating the source of trouble:

1. Check the TRIG SENS ADJUST and AVALANCE ADJUST settings as given in the Operating Instructions section.
2. Recalibrate the instrument. The procedure given in the Calibration section of this manual provides a step by step check of the various circuits that will isolate the trouble to a particular circuit.
3. Check the tubes or transistors in the suspected circuit. Most circuit failures are caused by tube or semiconductor failures resulting from normal aging and use. The recommended method of checking a tube or transistor is by direct substitution. However, before installing a replacement component, be sure the circuit voltages are approximately normal. If the circuit is not checked, the new component may be damaged by some defect in the circuit.

NOTE

Replace Q84 only with a Tektronix-selected transistor, as listed in the Parts List. A non-selected transistor will probably not operate correctly in the avalanche circuit.

4. Check the circuit in detail with a high-impedance voltmeter and a test oscilloscope. Normal circuit voltages and waveforms are given on the schematic diagram at the rear of this manual. Be careful when checking inside the instrument with meter leads and probe tips. Careless shorting of leads can apply abnormal voltages that may cause the destruction of semiconductors or other small components.

5. Repair and recalibrate the circuit. After any electrical component has been replaced, the calibration of that circuit and other related circuits should be checked. Calibration of the entire instrument should be checked if the power transformer has been replaced or work has been done in the power supply.

Troubleshooting Aids

The assigned circuit number of each component in the Type 111 is shown on the schematic circuit diagram. Inside the instrument, the circuit number of each tube, transistor, diode, electrolytic capacitor and internal control is marked on the chassis near the component. Thus, the circuit numbers provide correlation between the components in the instrument and the symbols on the schematic. All wiring in the instrument is color-coded for convenience in circuit tracing.

The sections of rotary switches are coded on the schematic to indicate the physical positions of the switch contacts. The sections are numbered from the front panel to the rear of the assembly. The letters F and R indicate whether the front or the rear of the section is used to perform the particular switching function.

Component Checking

Components that are soldered in place can usually be checked quickly by unsoldering one end. For example, a capacitor can be checked for a leaky or shorted condition by checking its resistance on a megohm scale. The resistance should read infinite as soon as the capacitor is charged. An open capacitor may best be detected with a capacitance meter or by checking the waveform on each side of the component with the circuit in operation.

An open condition in a resistor or inductor can be detected by an ohmmeter continuity check. Shorted or partially shorted inductors can usually be found by analysis of high-frequency signals passing through the circuit. Partial shorting reduces the frequency response (rolloff).

A junction diode can be checked for an open or shorted condition by making an ohmmeter check between terminals. With an ohmmeter scale using an internal source of 1½ volts, the resistance should measure very high in one direction and very low in the other.

CAUTION

Do not use an ohmmeter scale that uses a voltage source greater than approximately 3 volts. A high voltage applied in the reverse direction may exceed the junction breakdown voltage, giving an erroneous reading and possibly damaging the semiconductor.

SECTION 5

CALIBRATION

General Information

The Type 111 should be checked and recalibrated after each 500 hours of operation (at least once every six months) to insure that it is operating properly and accurately. In addition, portions of the instrument will require a calibration check if transistors are replaced or electrical repairs are made in the circuitry. For repair and servicing information, refer to the Maintenance section of this manual.

A complete verification and calibration procedure for the Type 111 is provided in this section. The steps that follow are arranged in a convenient sequence that avoids unnecessary repetition. The sequence includes procedures for checking performance as well as those required for adjusting calibration controls. If you desire only to set the calibration adjustments without checking performance of the instrument, perform only the steps entitled "Adjust. . . ⑦" and leave out the "Check" steps. However, the equipment should be set up as described in the Preliminary Procedure and the power supply outputs (steps 1 and 2) should be checked, whether a complete calibration or just a quick adjustment procedure is performed.

At the beginning of each step, the control settings and interconnections are assumed to be the same as they were at the end of the preceding step unless otherwise noted.

Do not preset any adjustments unless they are known to be out of adjustment or unless repairs have been made in the circuit. In these cases, set the particular controls to midrange.

Use short ground leads on the test probes of the conventional oscilloscope. Whenever a probe is connected to a test point, clip the ground lead to chassis ground. Failure to ground the probe cable will result in the appearance of ringing on the signal.

Equipment Required

The following (or equivalent) items of equipment are required for a complete calibration of the Type 111:

1. Test oscilloscope, conventional. Bandpass from dc to at least 24 Mc; deflection factors from 0.01 (or less) to 10 volts/div; sweep rates to at least 0.1 μ sec/div; ac and dc vertical input coupling; external triggering capability; voltage and timing accuracy $\pm 3\%$. Tektronix 540-Series Oscilloscope with Type 1A1 Plug-In Unit recommended.
2. Test oscilloscope, sampling-probe type. Equivalent risetime 0.35 nsec or less; deflection factors from 10 to 100 mv/div; equivalent sweep rates to at least 0.2 nsec/div; external triggering capability; voltage and timing accuracy $\pm 3\%$. Tektronix Type 561A Oscilloscope with Types 3S3 and 3T77 Plug-In Units recommended. If a sampling-probe system is not available, a 50-ohm sampling system may be substituted (with appropriate changes in the procedure).
3. Square-wave generator. Required only for checking external trigger operation and Pretrigger risetime. Output frequencies from 25 cps to at least 100 kc; output amplitude to at least 50 volts into a high impedance (1 megohm). Tektronix Type 105 Square-Wave Generator recommended.

4. Variable autotransformer. Output voltage variable from 105 to 125 volts ac rms for nominal 117-volt operation or from 210 to 250 volts ac rms for nominal 234-volt operation; output power 30 watts minimum.

5. Ac voltmeter for monitoring autotransformer output. Voltage range up to 125 volts rms for 117-volt operation, or to 250 volts for 234-volt operation; accuracy $\pm 3\%$.

6. Dc voltmeter. Voltage ranges from 0 to 150 volts; sensitivity of at least 20,000 Ω /volt; accuracy $\pm 3\%$.

7. Two 10X attenuator probes for conventional test oscilloscope. Tektronix P6006 Probes recommended. Tektronix part number 010-127 (BNC) or 010-125 (UHF).

8. 1X probe for conventional test oscilloscope. Required only for checking power supply ripple. Tektronix P6028 or P6027 Probe recommended. Tektronix part number 010-074 for P6028 (BNC); 010-070 for P6027 (UHF). A clip-lead adapter, Tektronix part number 013-076 (BNC) or 013-003 (UHF) with a coaxial cable may be substituted for the 1X probe.

9. Sampling probe or probes for sampling-type test oscilloscope. Tektronix P6038 Probes recommended (standard accessories with Tektronix Types 3S3 and 4S3 Sampling-Probe Units). Tektronix part number 010-156.

10. 9-nsec coaxial charge line. Coax type RG-58A/U; characteristic impedance 50 ohms; connector type (one end) 50-ohm GR; second end open and insulated. Tektronix part number 017-506. (Standard accessory with Type 111.)

11. 15.5-nsec coaxial charge line. Required only for checking maximum pulse duration at 100 kc. Coax type RG-58A/U or RG-8A/U; characteristic impedance 50 ohms; connector type (one end) 50-ohm GR; second end open and insulated. May be made by cutting a 20-nsec coaxial cable (Tektronix part number 017-504) and insulating the open end, or by installing a 50-ohm GR connector on the end of a length of 50-ohm coaxial cable. Total length of the cable and connector should be 124 $\frac{1}{2}$ inches. (If you wish to order connector and cable parts from Tektronix for assembling a 15.5-nsec RG-58A/U charge line, order 1 each of the following Tektronix part numbers: 062-166, 132-001, 132-002, 132-007, 132-028, 132-029, 132-043, 132-115, 132-116, 132-117, 132-119, 200-270 and 11 feet of 175-300.)

12. Coaxial cable. Length approximately 42 inches; characteristic impedance 50 to 52 ohms; connector type BNC or UHF. Tektronix part number 012-057 (BNC) or 012-001 (UHF).

13. Approximately 40 nsec of coaxial delay cable. Required only for checking Pretrigger Pulse risetime. May be RG-8A/U or RG-58A/U cables totaling 40 nsec in length.

14. Four 10X T-attenuators. Characteristic impedance 50 ohms; connector type 50-ohm GR. Tektronix part number 017-044.

15. Probe tip adapter. Sampling-probe tip to 50-ohm GR connector. Tektronix part number 017-076 for P6038 Probe.

16. Special external trigger checker. Provides 3-volt steps at 3 volts/ μ sec rate of rise when driven with a 25 cps to 100 kc 50-volt square wave (risetime approximately 20 nsec). Schematic and approximate output waveform of trigger checker are shown in Fig. 5-1.

Calibration—Type 111

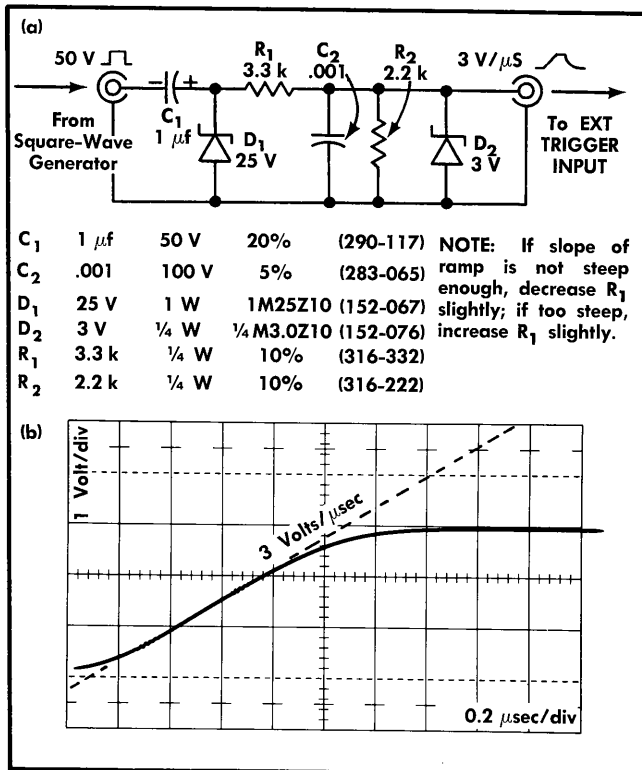

Fig. 5-1. External trigger checker: (a) Schematic diagram. Components may be mounted in any housing (such as an attenuator shell) with 50-ohm connectors. Six-digit numbers are Tektronix part numbers; (b) Typical output waveform when driven with a 50-volt 50-kc square-wave signal.

17. Insulated adjustment tools: screwdriver-type for adjusting potentiometers; low-capacitance tool for adjusting trimmer capacitor C77. Tektronix part numbers 003-000 and 003-003 recommended.

18. Coaxial T connector. Required only for checking Pre-trigger Pulse risetime. Tektronix part number 017-069 (GR), 103-030 (BNC) or 103-026 (UHF).

19. Connector adapters as needed for connecting between instruments with different connector types:

- BNC jack to GR connector. Tektronix part number 017-063.
- UHF jack to GR connector. Tektronix part number 017-022.
- BNC plug to GR connector. Tektronix part number 017-064.
- UHF plug to GR connector. Tektronix part number 017-023.
- BNC jack to UHF plug. Tektronix part number 103-015.
- UHF jack to BNC plug. Tektronix part number 103-032.

PRELIMINARY PROCEDURE

The following preliminary steps are performed before beginning the calibration procedure:

1. Remove both side panels from the Type 111.
2. Connect the test instruments and the autotransformer to the line voltage.

3. Connect the autotransformer output to the Type 111.
4. Install the 1X probe on the conventional test oscilloscope vertical input.
5. Install the sampling probes on the sampling-type test oscilloscope vertical inputs.

6. Set the front panel controls:

Type 111

REPETITION RATE	MAX
RANGE	EXT TRIG
OUTPUT POLARITY	+
VARIABLE	Centered
FIXED INCREMENT	0
POWER ON	Off (down)

Conventional Test Oscilloscope

Horiz mode	Normal
Sweep rate	5 msec/div
Triggering	+Line, Trig
Vertical mode	Normal (Channel 1)
Deflection factor	0.01 volts/div, Calibrated
Input coupling	Ac

Sampling Test Oscilloscope

Sweep mode	Normal
Magnification	X1
Equiv. sweep rate	5 nsec/div
Sampling rate	100 dots/div
Delay (Time Position)	Minimum delay
Triggering	External +
Vertical mode	A Only, Normal
Deflection factor	50 mv/div, Calibrated

7. Turn on the test instruments and the Type 111.

8. Monitor the autotransformer output with the ac voltmeter and set the autotransformer for the Type 111 design-center voltage (117 or 234 volts).

9. Allow at least 10 minutes for the instruments to warm up before making any checks or adjustments.

POWER SUPPLY

Refer to Table 5-1 for output voltage and ripple tolerances during the following checks. Test points are shown in Fig. 5-2.

1. Check Supply Voltages

a. Connect the dc voltmeter between chassis ground and the test point of each supply. Check for the correct supply voltage while varying the autotransformer output voltage from 105 to 125 (or 210 to 250 volts). The output of each

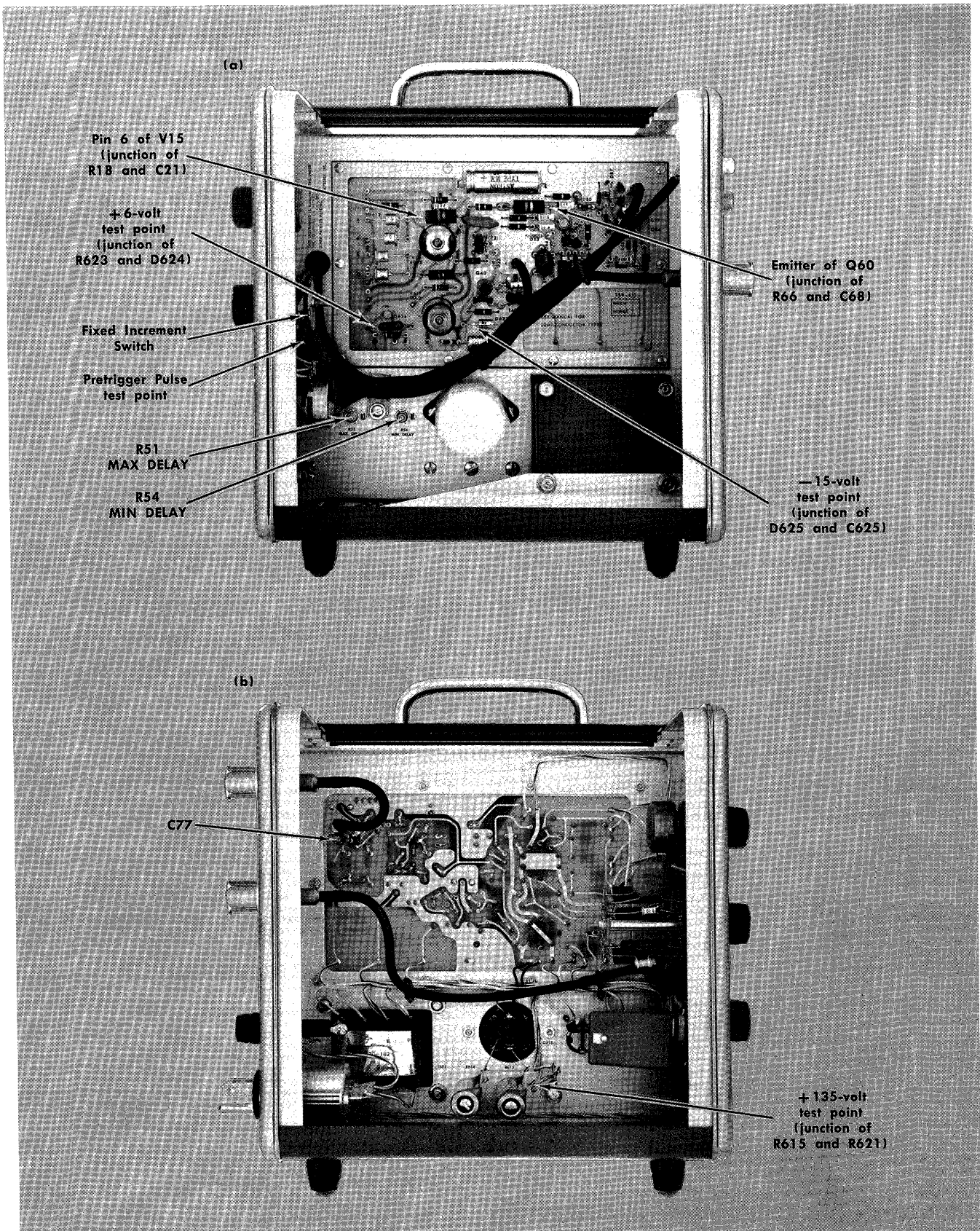

Fig. 5-2. Test Points and adjustments in the Type 111: (a) right side; (b) left side.

supply should remain within the specified regulation tolerance.

TABLE 5-1
Voltage Supplies

Supply	Regulation Tolerance 105-125 V (or 210-250 V)	Ripple (Max.)
+135 volts	±6.75 volts	10 mv
+6 volts	±0.60 volts	10 mv
-15 volts	±0.75 volts	10 mv

b. Disconnect the voltmeter.

2. Check Supply Ripple

a. Connect the tip of the 1X probe to each test point and check for power supply ripple while varying the autotransformer output voltage from 105 to 125 volts (or 210 to 250 volts).

b. Disconnect the test probe.

c. Remove the 1X probe from the test oscilloscope input and connect a 10X probe to the input.

d. Set the test oscilloscope for internal triggering.

e. Return the autotransformer output voltage to the design-center line voltage of the Type 111.

REPETITION RATE GENERATOR

3. Check Symmetry

a. Reset the following test oscilloscope controls:

Sweep rate	20 μ sec/div
Deflection factor	5 volts/div

c. Reset the following Type 111 controls:

RANGE	10 KC
REPETITION RATE	Centered

d. Connect the 10X test probe tip to pin 6 of V15 (see Fig. 5-2).

e. Trigger the test oscilloscope and check the displayed waveform for symmetry of 2:1 or less. If symmetry is greater than 2:1, either V15 is out of balance or there is a defective component in the circuit.

4. Check Repetition Rates

a. Set the test oscilloscope sweep rate to 10 μ sec/div.

b. (Refer to Table 5-2.) Vary the repetition rate with the RANGE switch and the REPETITION RATE control and check for correct operation of the Repetition Rate Generator circuit.

c. Disconnect the probe from the test point.

TABLE 5-2

Repetition Rates

RANGE	Test Sweep Rate	Display	
		REPETITION RATE Counterclockwise	REPETITION RATE Clockwise
10 KC	10 μ sec/div	≤ 1 cycle	≥ 10 cycles
1 KC	.1 msec/div	≤ 1 cycle	≥ 10 cycles
100 CPS	1 msec/div	≤ 1 cycle	≥ 10 cycles
10 CPS	10 msec/div	≤ 1 cycle	≥ 10 cycles

PRETRIGGER PULSE

5. Adjust Trigger Sensitivity

a. Install two 10X T-attenuators in series on the PRE-TRIGGER OUTPUT connector.

b. Reset the following conventional oscilloscope controls:

Sweep rate	20 μ sec/div
Deflection factor	0.5 volts/div

c. Connect the test probe tip to the Pretrigger Pulse test point on the Fixed Increment switch (see Fig. 5-3).

d. Reset the following Type 111 controls:

RANGE	10 KC
REPETITION RATE	Centered
TRIG SENS ADJUST	Clockwise

e. Trigger the test oscilloscope. The display should consist of the output pulses from the free-running Pretrigger blocking oscillator.

f. Turn the TRIG SENS ADJUST control counterclockwise just past the point where the Pretrigger Pulse Generator is triggered and the display remains stable. Approximately 3 pulses should appear in the display.

g. Set the test oscilloscope sweep rate to 0.1 μ sec/div.

h. Vary the repetition rate from 10 cps to 100 kc with the RANGE switch and the REPETITION RATE control. The Pretrigger Pulse should remain stable, but should not free run. Readjust the TRIG SENS ADJUST control if necessary.

6. Check Pretrigger Amplitude and Duration

a. Reset the following Type 111 controls:

RANGE	10 KC
REPETITION RATE	Centered

b. Check the displayed pulse for an amplitude of approximately 10 volts and a duration of from 240 to 360 nsec.

7. Check External Triggering

a. Set the RANGE switch to EXT. TRIG.

b. Set the square-wave generator for an output frequency of approximately 25 kc and an output amplitude of approxi-

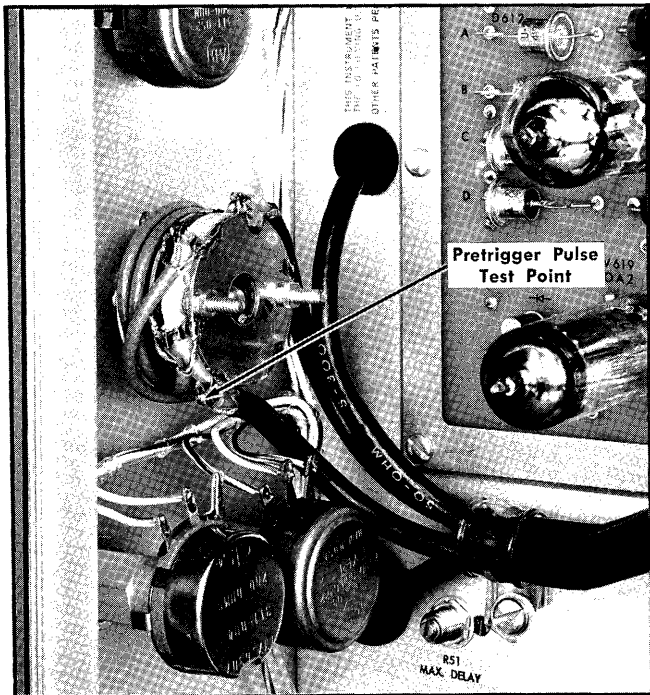

Fig. 5-3. Location of Pretrigger Pulse test point on FIXED INCREMENT switch.

mately 50 volts into a high impedance (monitor the signal with the conventional oscilloscope).

c. Connect the output of the special trigger checker to the EXT TRIGGER INPUT connector on the rear panel of the Type 111.

d. Connect the square-wave generator output through a coaxial cable to the input of the trigger checker.

e. With the test probe connected to the Pretrigger Pulse test point on the Fixed Increment switch and with the test oscilloscope sweep rate set to $0.1 \mu\text{sec}/\text{div}$, observe the Pretrigger Pulse display and vary the repetition rate of the square-wave generator from 25 cps to 100 kc. Triggering should remain stable. If not, the TRIG SENS ADJUST control may require a slight readjustment.

f. Disconnect the probe from the test point and remove the square-wave signal and trigger checker.

8. Check Pretrigger Rise Time

a. Set the square-wave generator for minimum output amplitude and an output frequency of approximately 25 kc.

b. Install two 10X T-attenuators in series on the external trigger input of the sampling oscilloscope, using an adapter if necessary. (Do not remove the attenuators from the Type 111 PRETRIGGER OUTPUT connector.)

c. Install a coaxial T-connector on the attenuators connected to the sampling oscilloscope trigger input.

d. Connect the square-wave signal through a coaxial cable to one arm of the T-connector.

e. Connect approximately 40 nsec of delay cable between the second arm of the T-connector and the EXT TRIGGER INPUT on the rear panel of the Type 111. Impedance of the delay cables is not critical. (Connect directly to the input, not through the trigger checker.)

f. Install a GR to sampling-probe adapter on the attenuators connected to the PRETRIGGER OUTPUT.

g. Connect the (Channel A) sampling probe by means of the adapter to the Pretrigger Pulse output signal.

h. Increase the output amplitude of the square-wave generator slowly until the Type 111 is triggered and the sampling oscilloscope is triggerable.

i. Adjust the oscilloscope triggering and positioning controls to present a stable display of the Pretrigger Pulse. Refer to the sampling unit instruction manual to set the Smoothing control for unity gain (use Normal Smoothing for a 50-ohm system).

j. Set the sampling oscilloscope sweep rate to 2 nsec/div.

k. Measure the 10% to 50% risetime of the Pretrigger Pulse (see Fig. 5-4). This risetime should be 5 nsec or less.

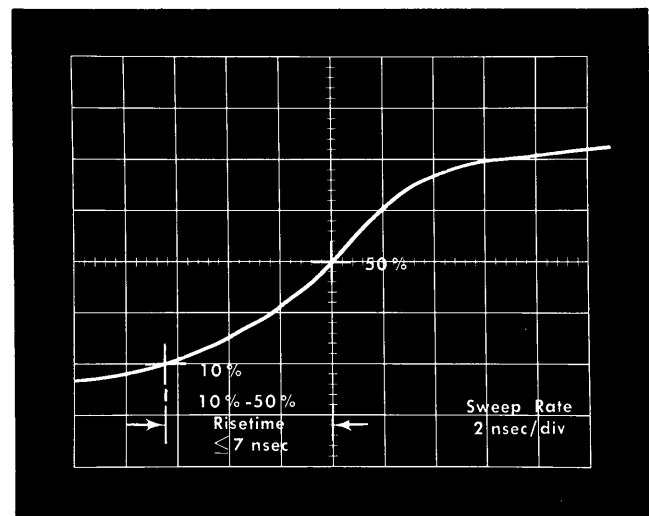

Fig. 5-4. Rise time measurement (10%-50%) of Pretrigger Pulse.

l. Disconnect the probe tip from the Pretrigger signal and remove the probe-tip adapter.

m. Disconnect the triggering-signal cables.

OUTPUT PULSE

9. Check Ramp Generator

a. Reset the following Type 111 controls:

RANGE	1 KC
REPETITION RATE	MAX
VARIABLE	MAX

b. Connect the probe tip of the conventional test oscilloscope to the emitter of Q60 (see Fig. 5-2).

Calibration—Type 111

- c. Set the test oscilloscope deflection factor to 0.2 volts/div.
- d. Trigger the oscilloscope display.
- e. Check for a ramp waveform similar to Fig. 5-5, with a ramp duration equal to the Pretrigger Pulse duration and an amplitude of approximately 3 volts. If the ramp amplitude is not correct, Q60 may require replacement.
- f. Disconnect the probe from the test point.

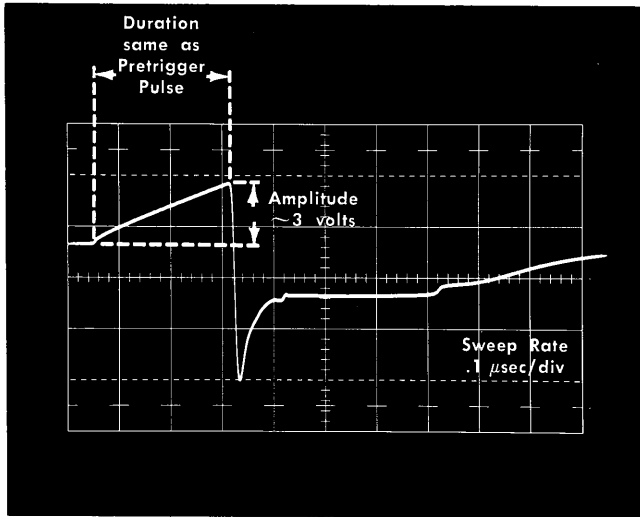

Fig. 5-5. Ramp waveform at emitter of Q60 with VARIABLE control set to MAX.

10. Adjust Avalanche

- a. Install two 10X T-attenuators in series on the PULSE OUTPUT connector. (Use the attenuators connected to the sampling oscilloscope external trigger input in step 8.) Do not remove the attenuators from the PRETRIGGER OUTPUT.
- b. Connect a 9-nsec 50-ohm charge line to the CHARGE LINE connector.
- c. Install the GR to sampling-probe adapter on the attenuators connected to the PULSE OUTPUT.
- d. Connect the sampling probe tip to the Output Pulse signal by means of the adapter.
- e. Connect a coaxial cable from the attenuators on the PRETRIGGER OUTPUT to the external trigger input of the sampling oscilloscope, using adapters as necessary.
- f. Reset the following controls on the sampling oscilloscope:

Equiv. sweep rate	5 nsec/div
Deflection factor	50 mv/div, Calibrated
- g. Trigger the sampling oscilloscope and adjust the positioning controls and the Type 111 VARIABLE control to display the Output Pulse on the crt screen. Set the sampling oscilloscope smoothing for unity gain.
- h. Adjust the Type 111 front-panel AVALANCHE ADJUST control for the best risetime, flattest top and minimum noise on the displayed pulse. Best operation usually occurs with

the AVALANCHE ADJUST control set as far clockwise as possible without causing erratic operation of the avalanche circuit. Pulse amplitude should be greater than 10 volts* and may be as high as 20 volts, depending on the characteristics of the avalanche transistor.

NOTE

When observing the amplitude, be sure to take into consideration that the vertical attenuation factor is only about 50X with the sampling-probe connected as described (see Note in Operating Instructions).

- i. With the RANGE switch and VARIABLE control, vary the repetition rate from 10 cps to 100 kc and check that the pulse shape and amplitude remain the same. If not, it may be necessary to replace Q84. As the repetition rate is increased from 50 to 100 kc, the pulse amplitude may decrease slightly (less than 2%). This is a normal condition. (If the sampling oscilloscope trigger circuit begins to count down sometime during this check, the display may appear unstable. This is a characteristic of the oscilloscope, not of the Type 111.)

11. Adjust Output Pulse Corner

- a. Reset the following Type 111 controls:

RANGE	10 KC
REPETITION RATE	Centered
- b. Set the sampling oscilloscope equivalent sweep rate to 2 nsec/div.
- c. Position the pulse rise to the center of the crt screen with the Type 111 VARIABLE control.
- d. Adjust C77 (see Fig. 5-2 for location of C77) for a square corner on the pulse without overshoot in excess of about 2%.

12. Check Output Pulse Risetime

- a. Set the sampling oscilloscope sweep rate to 0.2 nsec/div.
- b. Adjust the Type 111 VARIABLE control to position the pulse rise on the crt screen.
- c. Measure the 10-90% risetime of the displayed pulse (see Fig. 5-6). Risetime as displayed with the recommended sampling oscilloscope (Type 561A/3S3) should not exceed 615 psec with the Type 3S3 Noise-Risetime switch set at Fast RT and the Smoothing control set for unity gain. System risetime of 615 psec or less represents a risetime of 500 psec or less for the Type 111**. If the Type 111 risetime exceeds 500 psec, Q84 may require replacement unless sufficient improvement can be made by readjusting the AVALANCHE ADJUST control (step 10) and C77 (step 11).

13. Check Delay Jitter

- a. Reset the sampling oscilloscope Delay (Time Position) control for minimum delay.

*S/N 101-799: Pulse amplitude should be greater than 5 volts.

$$** \sqrt{(\text{displayed } T_r)^2 - (\text{Type 3S3 } T_r)^2} = \text{Type 111 } T_r$$

$$\sqrt{(\leq 615 \text{ psec})^2 - (\leq 350 \text{ psec})^2} = 500 \text{ psec}$$

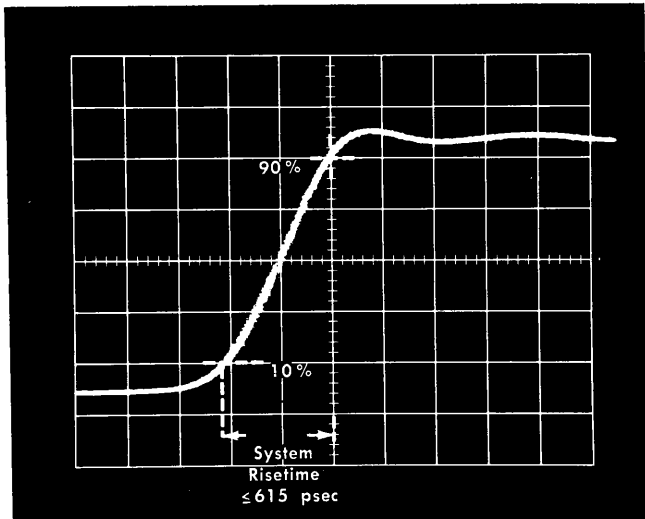

Fig. 5-6. Output pulse risetime measurement using sampling oscilloscope with 0.35 nsec risetime.

b. Center the pulse rise on the crt screen with the Type 111 VARIABLE control and observe the pulse for time jitter (thickness of the rising portion). Time jitter should not exceed 100 psec. Since delay jitter depends primarily on the turn-on characteristics of Q60 and Q84, it may be necessary to replace one or both of these transistors if jitter exceeds 100-psec. (If Q60 or Q84 are replaced, repeat steps 8 through 13 of this procedure.)

14. Check Pulse Top Aberrations

NOTE

Replacement of R85 and/or R87 in this step and step 15 will probably not be required unless Q84 has been replaced. R85 adjusts for pulse top tilt; R87 terminates the output.

- a. Set the sampling oscilloscope equivalent sweep rate to 5 nsec/div.
- b. Set the oscilloscope deflection controls so the displayed pulse extends from the bottom to the top of the graticule.
- c. Check the pulse top for aberrations and tilt. These should not exceed 5% of the pulse amplitude on a 20-nsec pulse*. If tilt exceeds 5%, it may be necessary to replace R85** as described later in this step. If aberrations exceed 5%, it may be necessary to replace R87 as described in step 15. However, sufficient improvement in the pulse top may be possible by readjustment of the AVALANCHE ADJUST control (see step 10). If the AVALANCHE ADJUST setting is changed, C77 will also require readjustment (see step 11).
- d. The following procedure is suggested for replacing R85 if tilt in the pulse top cannot be removed by adjustment of the AVALANCHE ADJUST control:

- (1) Unsolder R85 from the circuit, using the precautions for etched wiring board soldering given in the Maintenance section. See Fig. 5-7 for the location of R85.

*5/N 101-799: Pulse tilt should not exceed 10% of amplitude.
 **Does not apply below 5/N 800. (R85 was added at 5/N 800.)

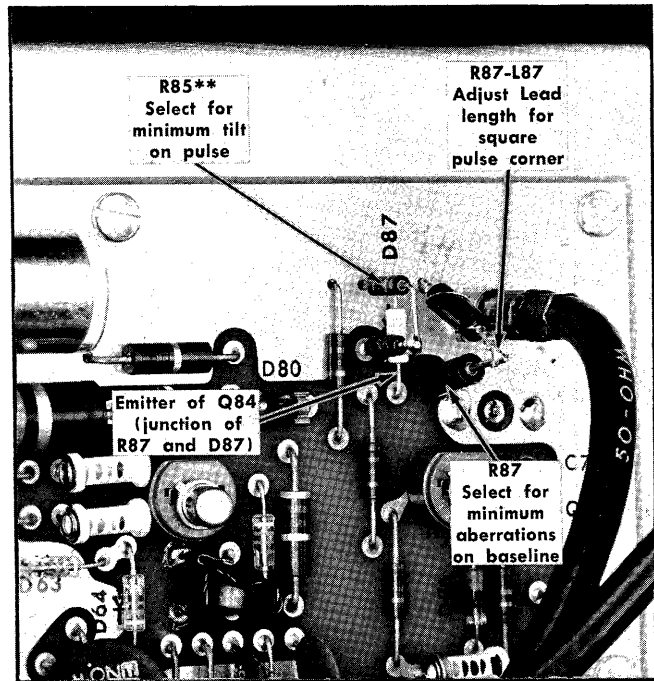

Fig. 5-7. Locations of R85** and R87 at output of avalanche circuit. See text for selection procedures.

- (2) Note the value of the resistor that was removed.

- (3) Select one or two 1/4-watt resistors of a higher value and one or two of a lower value than the one removed. The general range of resistance values is from 50 to 200 ohms.

- (4) Clip the resistor leads to resemble those of the one being removed.

- (5) Place each of the selected resistors temporarily in the circuit and check the pulse for a change in tilt of the pulse top. The correct values of R85 will produce a level top on the pulse.

- (6) After determining which resistor produces the least tilt, solder the new R85 into the circuit.

15. Check Baseline Aberrations

- a. With the sampling oscilloscope deflection controls set so the pulse covers the crt screen vertically, adjust the Type 111 VARIABLE control to display the falling edge of the pulse and the baseline following the pulse.

- b. Check for aberrations on the baseline following the pulse. These should not exceed 10% of the pulse amplitude. If aberrations and tilt of the baseline following the pulse exceed 10% of the amplitude, R87 may require replacement. However, before replacing R87, be sure to consider the effect that the charge line may have on the display. A charge line that has been damaged or one with an impedance other than 50 ohms will cause aberrations, tilt or an incorrect level following the pulse.

Calibration—Type 111

c. The following procedure is suggested for replacing R87:

(1) Unsolder R87 from the circuit, using the precautions for etched wiring board soldering given in the Maintenance section. See Fig. 5-7 for the location of R87.

(2) Note the value of the resistor that was removed.

(3) Select one or two 1/2-watt resistors of a higher value and one or two of a lower value than the one removed. The general range of resistance values is from 39 to 100 ohms.

(4) Clip one end of each resistor to match the short end of the resistor that was removed.

(5) Place each of the selected resistors temporarily in the circuit and observe the change produced in the display. With the correct value of R87, the baseline following the pulse will be flat with no large irregularities.

(6) Solder the short end of the new R87 to the etched wiring board connection.

(7) Before soldering the second lead of R87, touch it to the lead of L87 and observe the pulse at an equivalent sweep rate of 5 nsec/div.

(8) Move the resistor lead to change its effective length in series with L87 until the squarest possible leading corner is obtained on the pulse with minimum aberrations on the top and the baseline following the pulse.

(9) When the correct lead length has been determined, clip off the excess lead length and solder the resistor to L87.

16. Check Maximum Pulse Duration

a. Reset the following sampling oscilloscope controls:

Equiv. sweep rate	10 nsec/div
Deflection factor	50 mv/div, Calibrated

b. Reset the following Type 111 controls:

RANGE	10 KC
REPETITION RATE	MIN

c. Connect a 15.5-nsec charge line to the Type 111 rear-panel CHARGE LINE connector*.

d. Check the displayed pulse for a duration of 33 nsec*.

e. Turn the REPETITION RATE control slowly clockwise and observe the Output Pulse display as the repetition rate is increased from 10 kc to 100 kc. The pulse shape should remain constant and the pulse amplitude should not decrease more than 5%. (The sampling oscilloscope trigger circuit may count down during this check. See step 10i.)

f. Remove the 15.5-nsec charge line from the CHARGE LINE connector and reinstall the 9-nsec charge line.

*S/N 101-799: Use a 9-nsec charge line, producing a pulse duration of 20 nsec. Damage to the avalanche transistor may occur if a pulse duration exceeding 20 nsec is used at 100 kc.

17. Check Pulse Inverter

a. Reset the following Type 111 controls:

REPETITION RATE	Centered
OUTPUT POLARITY	—

b. Set the sampling oscilloscope equivalent sweep rate to 0.2 nsec/div.

c. Center the start of the inverted pulse on the crt screen with the sampling oscilloscope vertical Position or DC Offset controls and the Type 111 VARIABLE control.

d. Check the inverted pulse display for a risetime of 615 psec or less**.

e. Return the OUTPUT POLARITY switch to +.

18. Check Minimum Pulse Duration

a. Remove the 9-nsec charge line from the CHARGE LINE connector.

b. Set the sampling oscilloscope equivalent sweep rate to 1 nsec/div.

c. Center the displayed pulse on the crt screen.

d. Check the pulse at the 50% level for a minimum duration of 2 nsec or less.

e. Reconnect the 9-nsec charge line to the CHARGE LINE connector.

19. Check Fixed Increment

a. Set the sampling oscilloscope equivalent sweep rate to 0.5 nsec/div.

b. Position the pulse rise so it crosses the centerlines of the graticule.

c. Set the FIXED INCREMENT switch to +1 nSEC. The display should shift two major divisions (± 1 minor division) to the left.

d. Return the FIXED INCREMENT switch to 0.

20. Adjust Maximum Delay

a. Disconnect the sampling probe from the Pulse Output signal and remove the coaxial cable from the sampling oscilloscope external trigger input.

b. Reset the following conventional test oscilloscope controls:

Sweep rate	.1 μ sec/div
Deflection factor	.5 volts/div
Triggering	External +

c. The Type 111 controls should be set as follows:

RANGE	10 KC
REPETITION RATE	Centered
VARIABLE	MAX

**S/N 101-799: Inverted pulse display risetime may be slightly greater than 615 psec.

d. With one 10X probe connected to the vertical input connector of the conventional test oscilloscope, install a second 10X probe on the external trigger input connector.

e. Connect the tips of both probes to the Pretrigger Pulse test point on the Fixed Increment switch (see Fig. 5-3).

f. Adjust the test oscilloscope triggering to display the Pretrigger Pulse on the crt screen.

g. Adjust the oscilloscope positioning controls to position the 50% level of the pulse rise at the second vertical graticule line (see Fig. 5-8). Now do not change the triggering or position control settings of the test oscilloscope until both the MAX DELAY and MIN DELAY adjustments have been calibrated.

h. Move the tip of the vertical input probe to the emitter of Q84 (see Fig. 5-7).

i. Check the display for a pulse of approximately 25 nsec duration with the pulse rise occurring 260 nsec later than the

Pretrigger Pulse previously observed. (The rise should occur 3.6 major divisions from the left edge of the graticule.) See Fig. 5-8.

j. If the maximum delay time is not correct, adjust R51 (MAX DELAY).

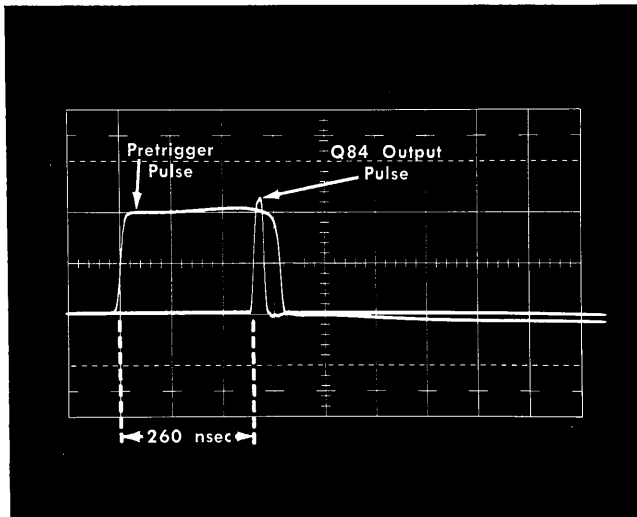

Fig. 5-8. Double exposure of Pretrigger Pulse and Q84 Output Pulse with VARIABLE control set to MAX and R51 (MAX DELAY) adjusted correctly.

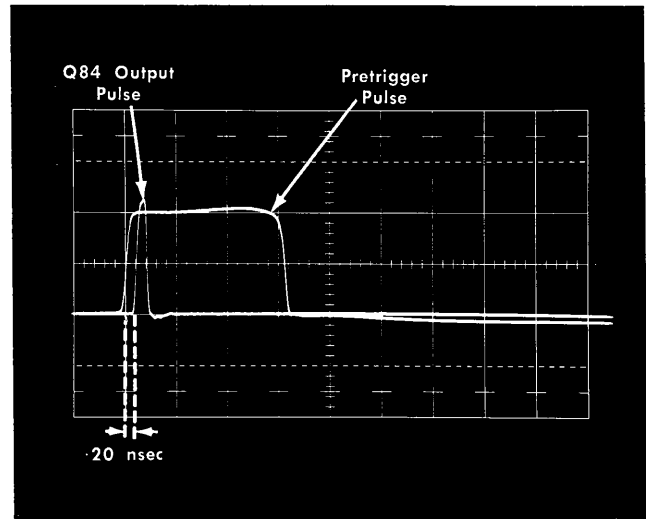

Fig. 5-9. Double exposure of Pretrigger Pulse and Q84 Output Pulse with VARIABLE control set to MIN and R54 (MIN DELAY) adjusted correctly.

21. Adjust Minimum Delay

a. With the display set up as at the end of step 20, turn the Type 111 VARIABLE control to MIN (fully counterclockwise).

b. Check that the pulse rise now occurs 20 nsec later than the Pretrigger Pulse. (The rise should now occur 1.2 major divisions from the left edge of the graticule.) See Fig. 5-9.

c. If the minimum delay is not correct, adjust R54 (MIN DELAY).

d. If it was necessary to adjust R54 (MIN DELAY), repeat steps 20 and 21. These adjustments interact.

e. Disconnect all probes, attenuators, cables and adapters.

SECTION 6

PARTS LIST and DIAGRAMS

PARTS ORDERING INFORMATION

Replacement parts are available from or through your local Tektronix Field Office.



Changes to Tektronix instruments are sometimes made to accommodate improved components as they become available, and to give you the benefit of the latest circuit improvements developed in our engineering department. It is therefore important, when ordering parts, to include the following information in your order: Part number including any suffix, instrument type, serial number, and modification number if applicable.

If a part you have ordered has been replaced with a new or improved part, your local Tektronix Field Office will contact you concerning any change in part number.

ABBREVIATIONS AND SYMBOLS

a or amp	amperes	mm	millimeter
BHS	binding head steel	meg or M	megohms or mega (10 ⁶)
C	carbon	met.	metal
cer	ceramic	μ	micro, or 10 ⁻⁶
cm	centimeter	n	nano, or 10 ⁻⁹
comp	composition	Ω	ohm
cps	cycles per second	OD	outside diameter
crt	cathode-ray tube	OHS	oval head steel
CSK	counter sunk	p	pico, or 10 ⁻¹²
dia	diameter	PHS	pan head steel
div	division	piv	peak inverse voltage
EMC	electrolytic, metal cased	plstc	plastic
EMT	electrolytic, metal tubular	PMC	paper, metal cased
ext	external	poly	polystyrene
f	farad	Prec	precision
F & I	focus and intensity	PT	paper tubular
FHS	flat head steel	PTM	paper or plastic, tubular, molded
Fil HS	fillister head steel	RHS	round head steel
g or G	giga, or 10 ⁹	rms	root mean square
Ge	germanium	sec	second
GMV	guaranteed minimum value	Si	silicon
h	henry	S/N	serial number
hex	hexagonal	t or T	tera, or 10 ¹²
HHS	hex head steel	TD	toroid
HSS	hex socket steel	THS	truss head steel
HV	high voltage	tub.	tubular
ID	inside diameter	v or V	volt
incd	incandescent	Var	variable
int	internal	w	watt
k or K	kilohms or kilo (10 ³)	w/	with
kc	kilocycle	w/o	without
m	milli, or 10 ⁻³	WW	wire-wound
mc	megacycle		

SPECIAL NOTES AND SYMBOLS

X000	Part first added at this serial number.
000X	Part removed after this serial number.
*000-000	Asterisk preceding Tektronix Part Number indicates manufactured by or for Tektronix, or reworked or checked components.
Use 000-000	Part number indicated is direct replacement.
	Internal screwdriver adjustment.
	Front-panel adjustment or connector.

FRONT

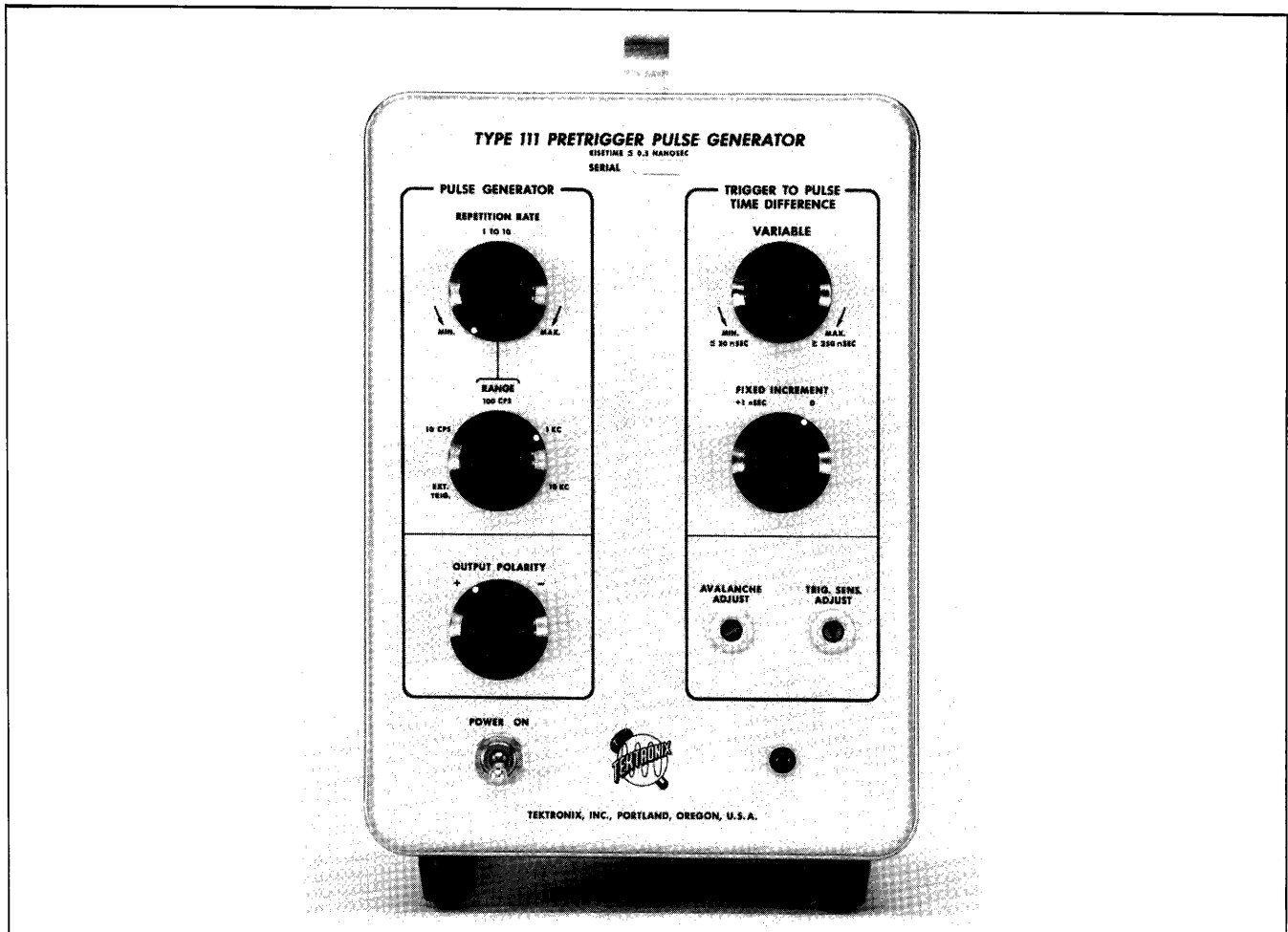

REF. NO.	PART NO.	SERIAL/MODEL NO.		QTY.	DESCRIPTION
		EFF.	DISC.		
1	366-0028-00	101	949	1	KNOB, large black—VARIABLE
	366-0145-00	950		1	KNOB, large charcoal—VARIABLE
	-----			-	knob includes:
	213-0004-00			1	SCREW, set, 6-32 x 3/16 inch HSS
	-----			1	POT
	-----			-	mounting hardware: (not included w/pot)
	210-0013-00			1	LOCKWASHER, internal, 3/8 x 11/16 inch
210-0840-00		1	WASHER, .390 ID x 9/16 inch OD		
210-0413-00		1	NUT, hex, 3/8-32 x 1/2 inch		
2	366-0028-00	101	949	1	KNOB, large black—REPETITION RATE
	366-0145-00	950		1	KNOB, large charcoal—REPETITION RATE
	-----			-	knob includes:
	213-0004-00			1	SCREW, set, 6-32 x 3/16 inch HSS
	-----			1	POT
	-----			-	mounting hardware, (not included w/pot)
	210-0013-00			1	LOCKWASHER, internal, 3/8 x 11/16 inch
210-0840-00		1	WASHER, .390 ID x 9/16 inch OD		
210-0413-00		1	NUT, hex, 3/8-32 x 1/2 inch		

FRONT (Cont'd)

REF. NO.	PART NO.	SERIAL/MODEL NO.		QTY.	DESCRIPTION
		EFF.	DISC.		
3	366-0028-00	101	949	1	KNOB, large black—FIXED INCREMENT
	366-0145-00	950		1	KNOB, large charcoal—FIXED INCREMENT
	- - - - -			-	knob includes:
	213-0004-00			1	SCREW, set 6-32 x $\frac{3}{16}$ inch HSS
	262-0358-00			1	SWITCH, wired—FIXED INCREMENT
	- - - - -			-	switch includes:
	260-0342-00			1	SWITCH, unwired—FIXED INCREMENT
	132-0032-00	X420	599	1	FERRULE
	132-0120-00	600		1	FERRULE
	166-0240-00	X420	879	1	TUBE, coaxial adapter
	131-0326-00	880		1	CONNECTOR, cable termination
	175-0095-00			1	CABLE, pre-trigger output
	- - - - -			-	cable includes:
	132-0001-00			1	COUPLING, nut
	132-0002-00			1	SLEEVE, conductor, outer
	132-0007-00			1	RING, snap
	132-0026-00	101	599	1	TRANSITION, outer
	132-0115-00	600		1	TRANSITION, outer
	132-0027-00	101	599	1	TRANSITION, inner
	132-0116-00	600		1	TRANSITION, inner
	132-0028-00			1	INSULATOR
	132-0029-00			1	CONDUCTOR, inner
	132-0032-00	101	599	1	FERRULE
	132-0117-00	600		1	FERRULE
	132-0119-00	X600		1	DISC, teflon
	- - - - -			-	mounting hardware: (not included w/cable alone)
	132-0016-00	101	688	1	NUT, retaining
	132-0121-00	689		1	NUT, retaining
	- - - - -			-	mounting hardware: (not included w/switch)
	210-0013-00			1	LOCKWASHER, internal, $\frac{3}{8}$ x $\frac{1}{16}$ inch
	210-0840-00			1	WASHER, .390 ID x $\frac{9}{16}$ inch OD
	210-0413-00			1	NUT, hex, $\frac{3}{8}$ -32 x $\frac{1}{2}$ inch
4	- - - - -			2	POT
	- - - - -			-	mounting hardware for each: (not included w/pot)
	210-0207-00			1	LUG, solder, $\frac{3}{8}$ inch
	210-0494-00			1	NUT, hex, $\frac{3}{8}$ -32 x $\frac{1}{2}$ x $\frac{1}{16}$ inch
	210-0013-00			1	LOCKWASHER, internal, $\frac{3}{8}$ x $\frac{1}{16}$ inch
358-0010-00			1	BUSHING, aluminum	
5	136-0047-00			1	SOCKET, light, w/jewel and nut
6	260-0134-00			1	SWITCH, toggle—POWER ON
	- - - - -			-	switch includes:
	210-0414-00			1	NUT, hex, $\frac{15}{32}$ -32 x $\frac{9}{16}$ inch
	- - - - -			-	mounting hardware: (not included w/switch)
	354-0055-00			1	RING, locking, switch
210-0902-00			1	WASHER, .470 ID x $\frac{21}{32}$ inch OD	
210-0473-00			1	NUT, switch, $\frac{15}{32}$ -32 x $\frac{5}{64}$ inch, 12 sided	

FRONT (Cont'd)

REF. NO.	PART NO.	SERIAL/MODEL NO.		QTY.	DESCRIPTION	
		EFF.	DISC.			
7	366-0028-00	101	949	1	KNOB, large black—OUTPUT POLARITY	
	366-0145-00	950		1	KNOB, large charcoal—OUTPUT POLARITY	
	- - - - -			-	knob includes:	
	213-0004-00			1	SCREW, set, 6-32 x 3/16 inch HSS	
	262-0359-00	101	799	1	SWITCH, wired—OUTPUT POLARITY	
	262-0675-00	800		1	SWITCH, wired—OUTPUT POLARITY	
	- - - - -			-	switch includes:	
	260-0342-00			1	SWITCH, unwired—OUTPUT POLARITY	
	124-0126-00	101	799X	2	STRIP, bronze	
	132-0032-00	X420	599	1	FERRULE	
	132-0120-00	600		1	FERRULE	
	166-0240-00	X420	799	1	TUBE, coaxial adapter	
	131-0326-00	800		1	CONNECTOR, cable termination	
	426-0087-00	X800		1	FRAME, toroid housing	
	210-0004-00			2	LOCKWASHER, internal, #4	
	210-0406-00			2	NUT, hex, 4-40 x 3/16 inch	
	200-0227-00	X800		1	COVER, toroid housing	
	175-0096-00			1	CABLE, pulse output	
	- - - - -			-	cable includes:	
	132-0001-00			1	COUPLING, nut	
	132-0002-00			1	SLEEVE, conductor, outer	
	132-0007-00			1	RING, snap	
	132-0026-00	101	599	1	TRANSITION, outer	
	132-0115-00	600		1	TRANSITION, outer	
	132-0027-00	101	599	1	Transition, inner	
	132-0116-00	600		1	Transition, inner	
	132-0028-00			1	INSULATOR	
	132-0029-00			1	CONDUCTOR, inner	
	132-0032-00	101	599	1	FERRULE	
	132-0117-00	600		1	FERRULE	
	132-0119-00	X600		1	DISC, teflon	
	- - - - -			-	mounting hardware: (not included w/cable alone)	
	132-0016-00	101	688	1	NUT, retaining	
	132-0121-00	689		1	NUT, retaining	
	- - - - -			-	mounting hardware: (not included w/switch)	
	210-0013-00			1	LOCKWASHER, internal, 3/8 x 11/16 inch	
	210-0840-00			1	WASHER, .390 ID x 9/16 inch OD	
	210-0413-00			1	NUT, hex, 3/8-32 x 1/2 inch	
	8	366-0028-00	101	949	1	KNOB, large charcoal—RANGE
		366-0145-00	950		1	KNOB, large charcoal—RANGE
- - - - -				-	knob includes:	
213-0004-00				1	SCREW, set, 6-32 x 3/16 inch HSS	
262-0357-00				1	SWITCH, wired—RANGE	
- - - - -				-	switch includes:	
260-0343-00				1	SWITCH, unwired—RANGE	
- - - - -				-	mounting hardware: (not included w/switch)	
210-0013-00			1	LOCKWASHER, internal, 3/8 x 11/16 inch		
210-0840-00			1	WASHER, .390 ID x 9/16 inch OD		
210-0413-00			1	NUT, hex, 3/8-32 x 1/2 inch		
9	333-0602-00			1	PANEL, front	
	387-0258-00			1	PLATE, front sub-panel	
	- - - - -			-	plate includes:	
	354-0067-00			1	RING, ornamental	

CABINET

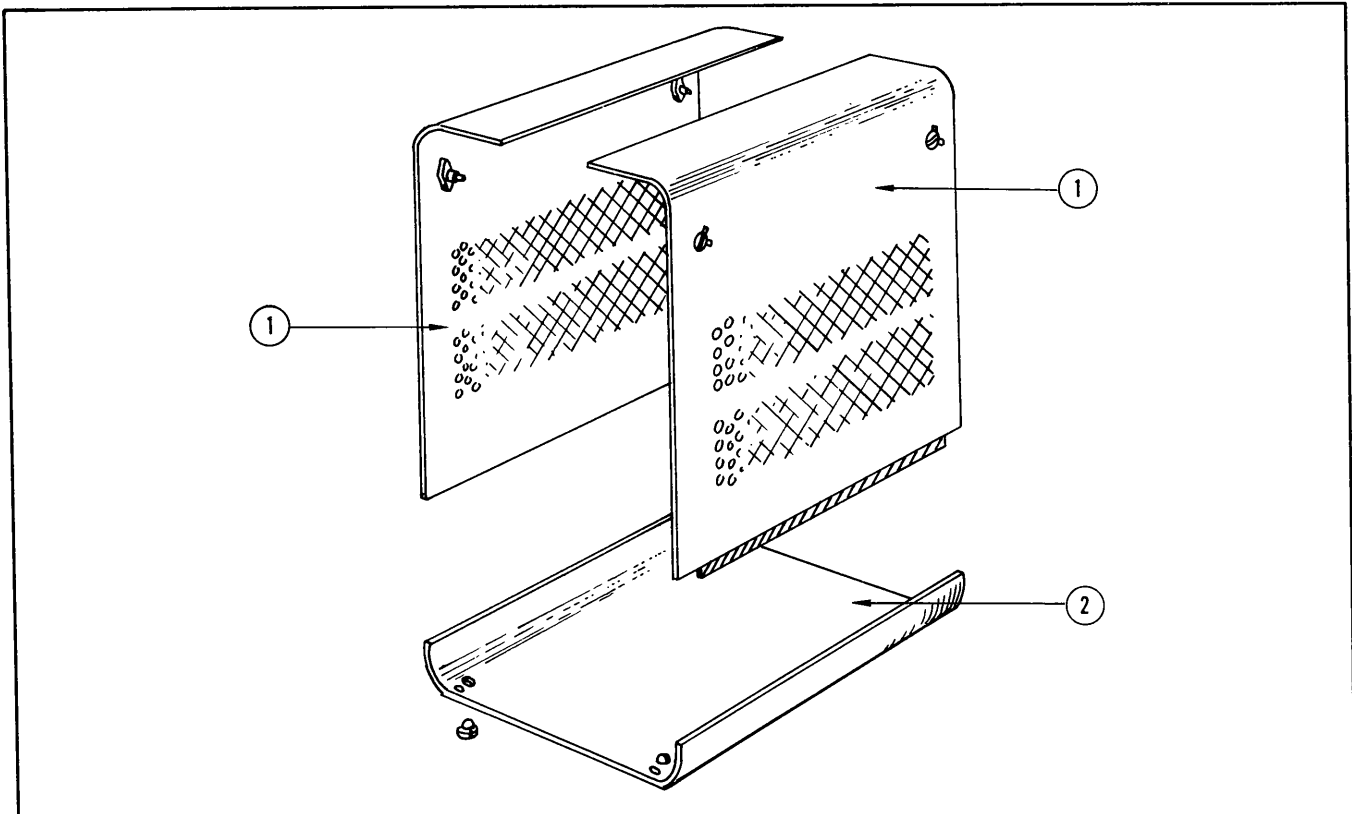

REF. NO.	PART NO.	SERIAL/MODEL NO.		QTY.	DESCRIPTION
		EFF.	DISC.		
1	387-261			2	PLATE, cabinet side
	- - - -			-	each plate includes:
	105-009			2	STOP
	210-470			2	NUT, cabinet fastener
	210-870			2	WASHER, $\frac{9}{64}$ ID x $\frac{5}{16}$ inch OD
	213-040			2	SCREW, fastening, 6-32 x $\frac{3}{8}$ inch
2	387-350			1	PLATE, cabinet bottom
	- - - -			-	plate includes:
	348-015			4	CUSHION, rubber ball
	348-014			4	FOOT, molded black
	- - - -			-	mounting hardware for each: (not included w/foot alone)
	212-010			1	SCREW, 8-32 x $\frac{5}{8}$ inch BHS
	210-804			1	WASHER, 8S x $\frac{3}{8}$ inch
	210-458			1	NUT, keps, 8-32 x $\frac{11}{32}$ inch
	- - - -			-	mounting hardware: (not included w/plate)
	211-542			4	SCREW, 6-32 x $\frac{5}{16}$ inch THS phillips
	210-457			4	NUT, keps 6-32 x $\frac{5}{16}$ inch

REAR

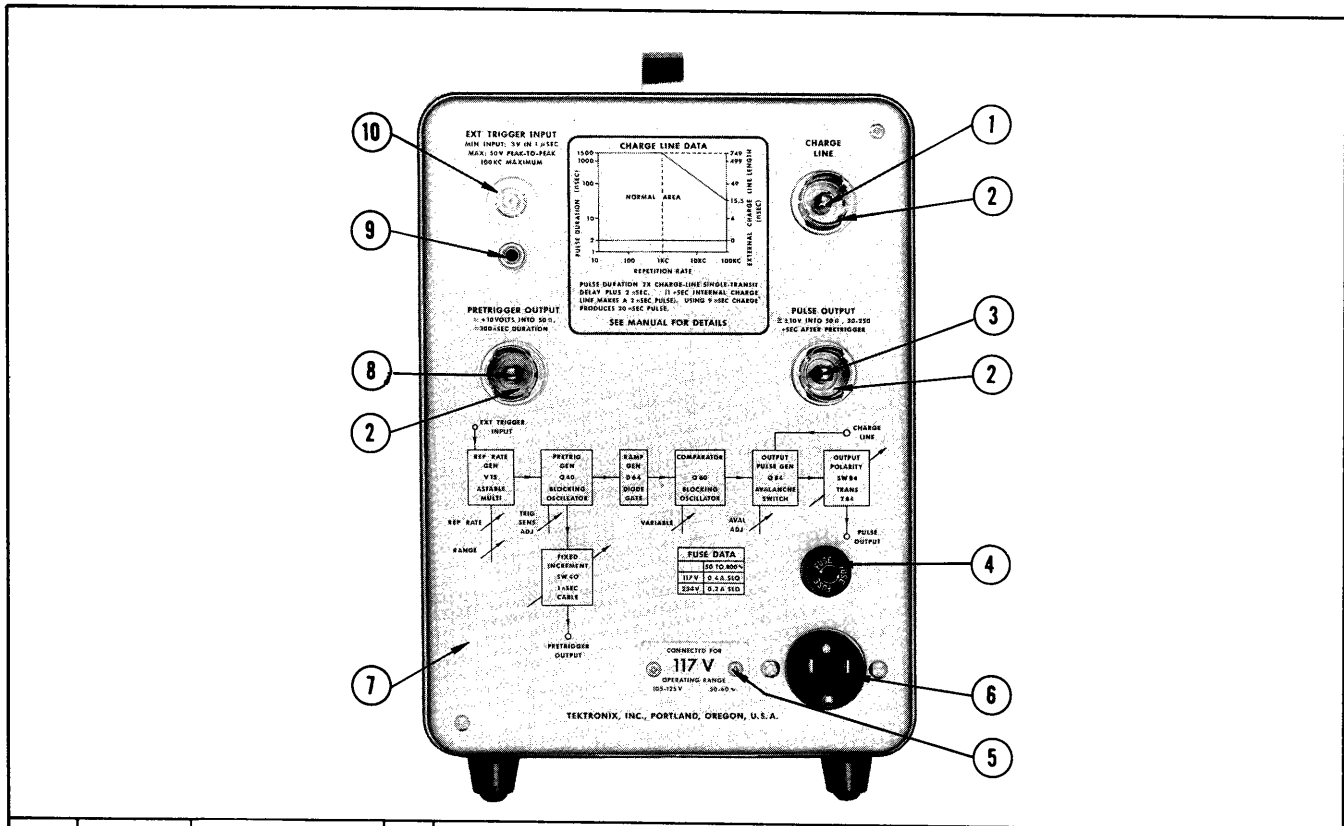

REF. NO.	PART NO.	SERIAL/MODEL NO.		QTY.	DESCRIPTION
		EFF.	DISC.		
1	- - - -			-	SUBPARTS OF CHARGE LINE CABLE ASSEMBLY (see LEFT SIDE)
2	132-040			3	ADAPTER, panel
	- - - -			-	mounting hardware for each: (not included w/adapter)
	211-038			4	SCREW, 4-40 x 5/16 inch FHS phillips
3	- - - -			-	SUBPARTS OF OUTPUT POLARITY SWITCH (see FRONT)
4	352-002			1	ASSEMBLY, fuse holder
	- - - -			-	assembly includes:
	352-010			1	HOLDER, fuse
	200-582			1	CAP, fuse
	210-873			1	WASHER, rubber, 1/2 ID x 1 1/16 inch OD
	- - - -			1	NUT, fuse holder
5	334-650			1	TAG, voltage rating
	- - - -			-	mounting hardware: (not included w/tag)
	213-088			2	SCREW, thread forming, 4-40 x 1/4 inch PHS phillips

REAR (Cont'd)

REF. NO.	PART NO.	SERIAL/MODEL NO.		QTY.	DESCRIPTION
		EFF.	DISC.		
6	650-0204-00			1	ASSEMBLY, line filter
	- - - - -			-	assembly includes:
	131-0102-00	101	1189	1	CONNECTOR, chassis mounted, motor base
	131-0102-01	1190		1	CONNECTOR, chassis mounted, motor base
	- - - - -			-	connector includes:
	129-0041-00	101	1189	1	POST, ground, 4-40 thread one end
	129-0041-01	1190		1	POST, ground, 4-40 thread one end
	200-0185-00	101	1189	1	COVER, plastic
	200-0185-01	1190		1	COVER, plastic
	210-0003-00	101	1189X	2	LOCKWASHER, external, #4
	210-0551-00	101	1189X	2	NUT, hex, 4-40 x 1/2 inch
	211-0132-00	X1190		1	SCREW, sems, 4-40 x 1/2 inch, PHS
	211-0015-00	101	1189	1	SCREW, 4-40 x 1/2 inch RHS
	213-0088-00	1190		1	SCREW, thread forming, 4-40 x 1/4 inch, PHS
	214-0078-00			2	PIN, connecting
	377-0041-00	101	1189	1	INSERT, black urea
	377-0051-00	1190		1	INSERT, black urea
	386-0933-00			1	PLATE, motor base
	361-0015-00			1	SPACER, line filter
	387-0025-00			1	PLATE, liner filter cap
	- - - - -			-	mounting hardware: (not included w/line filter assy)
	211-0552-00			2	SCREW, 6-32 x 2 inches BHS
	210-0457-00			2	NUT, keps, 6-32 x 5/16 inch
7	387-0259-00	101	240	1	PLATE, rear overlay
	333-0652-00	241	1009	1	PANEL, rear
	333-0652-01	1010		1	PANEL, rear
	- - - - -			-	mounting hardware: (not included w/panel)
	213-0088-00			4	SCREW, thread forming, 4-40 x 1/4 inch PHS, phillips
	387-0260-00			1	PLATE, rear sub-panel
	- - - - -			-	plate includes:
	354-0067-00			1	RING, ornamental
8	- - - - -			-	SUBPARTS OF FIXED INCREMENT SWITCH (See FRONT)
9	129-0053-00			1	POST, binding
	- - - - -			-	post includes:
	355-0507-00			1	STEM, adapter
	200-0103-00			1	CAP
	- - - - -			-	mounting hardware: (not included w/post)
	210-0223-00			1	LUG, solder, 1/4 inch
	210-0455-00			1	NUT, hex, 1/4-28 x 3/8 inch
10	131-0081-00	101	659	1	CONNECTOR, chassis mounted, 1 contact, UHF
	131-0126-00	660		1	CONNECTOR, chassis mounted, 1 contact, BNC

RIGHT SIDE

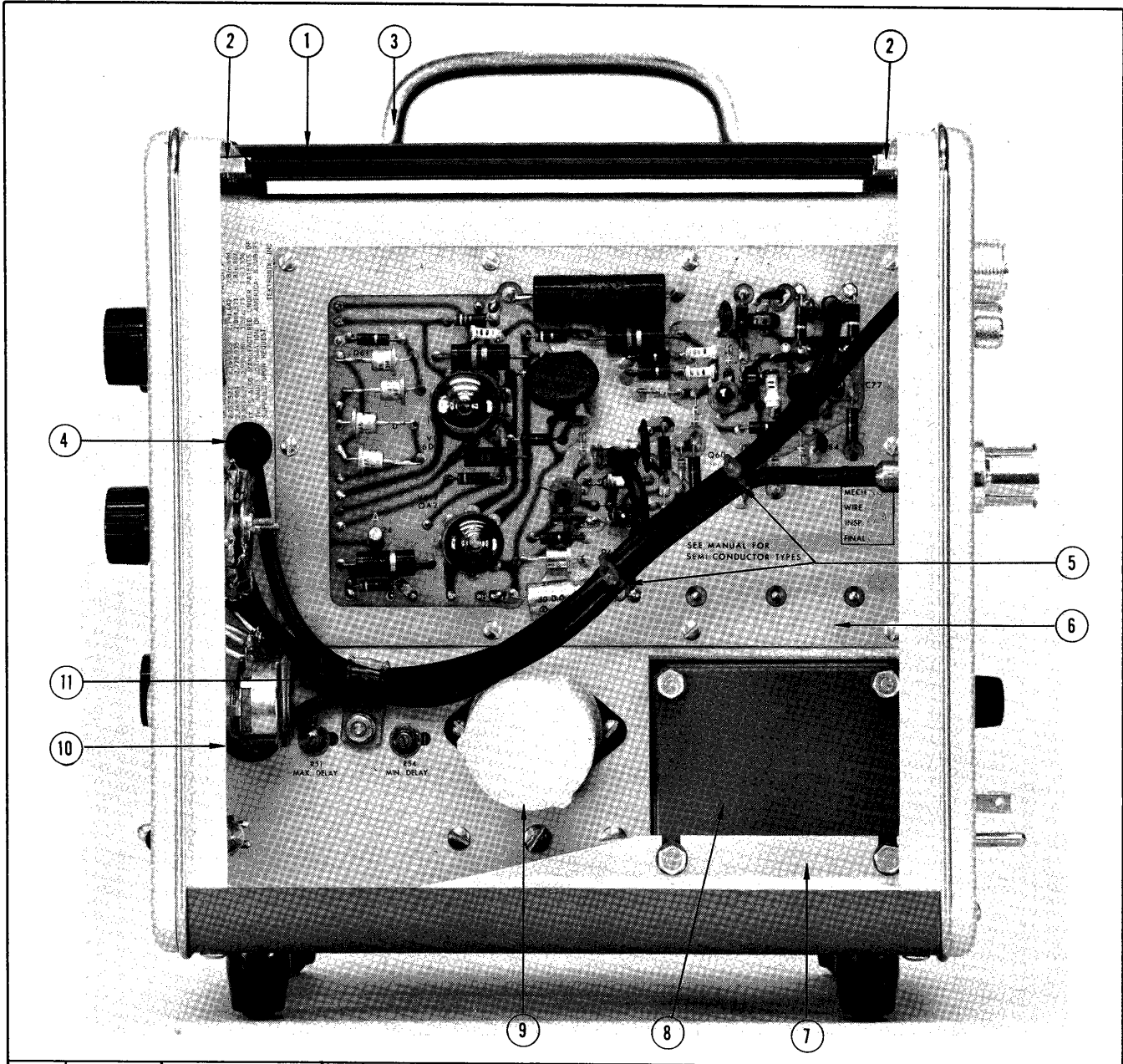

REF. NO.	PART NO.	SERIAL/MODEL NO.		QTY.	DESCRIPTION
		EFF.	DISC.		
1	381-159 - - - - 211-537			1	BAR, support mounting hardware: (not included w/bar)
2	381-084			4	SCREW, 6-32 x 3/8 inch THS phillips
				2	BAR, retaining
3	367-007 - - - - 212-004			1	HANDLE
				1	mounting hardware: (not included w/handle)
				2	SCREW, 8-32 x 5/16 inch BHS

RIGHT SIDE (Cont'd)

REF. NO.	PART NO.	SERIAL/MODEL NO.		QTY.	DESCRIPTION
		EFF.	DISC.		
4	348-0004-00			1	GROMMET, $\frac{3}{8}$ inch
5	346-0023-00	X380	508X	2	STRAP, cable tie
6	670-0063-00	101	799	1	ASSEMBLY, etched circuit board
	670-0068-00	800		1	ASSEMBLY, etched circuit board
	-----			-	assembly includes:
	387-0299-00	101	879	1	PLATE, circuit board
	388-0610-00	880		1	BOARD, circuit
	136-0058-00			1	SOCKET, 7 pin, tube
	136-0061-00			1	SOCKET, 9 pin, tube
	136-0062-00	101	879	3	SOCKET, 4 pin
	136-0183-00	880		3	SOCKET, 3 pin transistor
	344-0108-00	X880		2	CLIP, diode
	-----			-	mounting hardware: (not included w/assembly)
	211-0008-00	101	1049	10	SCREW, 4-40 x $\frac{1}{4}$ inch BHS
	211-0116-00	1050		10	SCREW, sems, 4-40 x $\frac{5}{16}$ inch PHB
	210-0004-00			10	LOCKWASHER, internal, #4
	210-0406-00			10	NUT, hex, 4-40 x $\frac{3}{16}$ inch
7	406-0714-00	X380		1	BRACKET, transformer support
8	-----			1	TRANSFORMER
	-----			-	mounting hardware: (not included w/transformer)
	212-0515-00			4	SCREW, 10-32 x $2\frac{1}{4}$ inches HHS
	210-0812-00			2	WASHER, fiber, #10
	210-0805-00			2	WASHER, 10S x $\frac{7}{16}$ inch
	220-0410-00			4	NUT, keps, 10-32 x $\frac{3}{8}$ inch
9	200-0258-00			1	COVER, capacitor
10	348-0012-00			1	GROMMET, $\frac{5}{8}$ inch
11	343-0006-00			1	CLAMP, cable, $\frac{1}{2}$ inch
	-----			-	mounting hardware: (not included w/clamp)
	211-0510-00			1	SCREW, 6-32 x $\frac{3}{8}$ inch BHS
	210-0803-00			1	WASHER, 6L x $\frac{3}{8}$ inch
	210-0457-00			1	NUT, keps, 6-32 x $\frac{5}{16}$ inch

LEFT SIDE

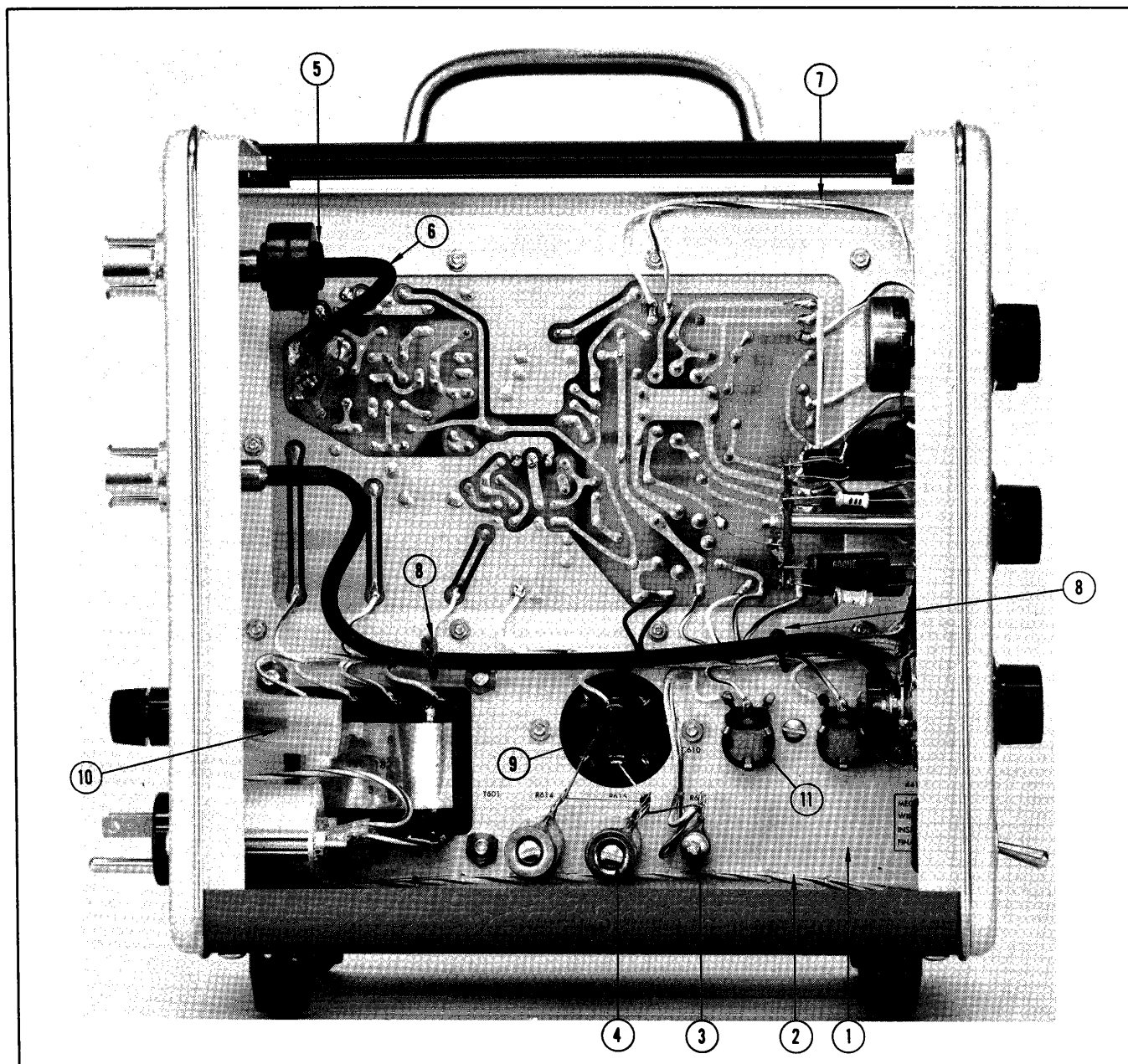

REF. NO.	PART NO.	SERIAL/MODEL NO.		QTY.	DESCRIPTION
		EFF.	DISC.		
1	441-327 - - - - 211-538 210-006 210-202 210-407			1 - 6 5 1 6	CHASSIS, aluminum mounting hardware: (not included w/chassis) SCREW, 6-32 x 5/16 inch FHS phillips LOCKWASHER, internal, #6 LUG, solder, SE #6 NUT, hex, 6-32 x 1/4 inch
2	179-471			1	CABLE HARNESS, 110 volt

STANDARD ACCESSORIES

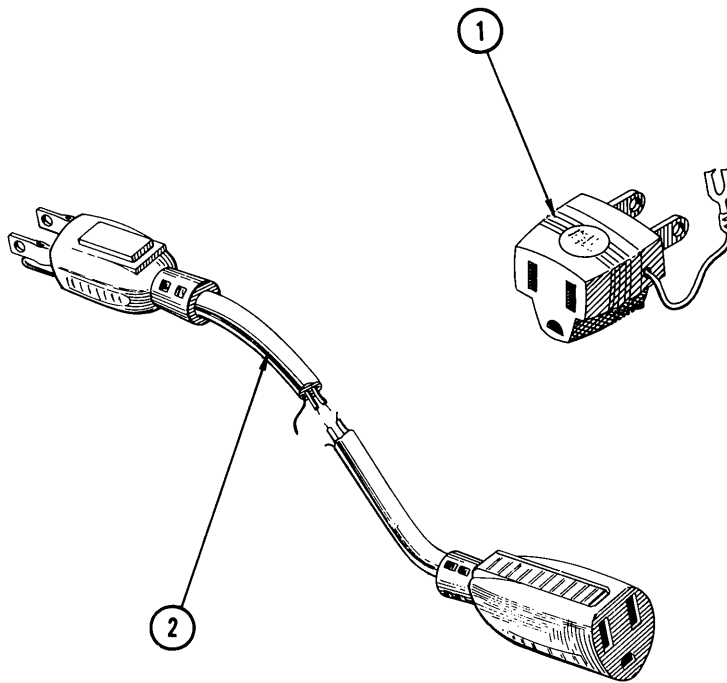

REF. NO.	PART NO.	SERIAL/MODEL NO.		QTY.	DESCRIPTION
		EFF.	DISC.		
--	020-0003-00			1	ACCESSORIES PACKAGE
1	103-0013-00			1	ADAPTER, power cord
2	161-0010-00	101	1299	1	CORD, power
	161-0010-03	1300		1	CORD, power
--	070-0252-00			2	MANUAL, instruction (not shown)

PARTS LIST

Values are fixed unless marked Variable.

Ckt. No.	S/N Range	Description	Tektronix Part Number
----------	-----------	-------------	--------------------------

Bulbs

B601		Incandescent, Pilot Light	150-018
------	--	---------------------------	---------

Capacitors

Tolerance $\pm 20\%$ unless otherwise indicated.

C12A		0.1 μf	Discap		200 v		Use 283-057
C12B		.047 μf	MT		400 v		285-519
C12C		.0047 μf	MT		400 v		285-506
C12D		470 pf	Cer.		500 v		281-525
C12E		39 pf	Cer.		500 v	10%	281-517
C16B		.047 μf	MT		400 v		285-519
C16C		.0047 μf	MT		400 v		285-506
C16D		470 pf	Cer.		500 v		281-525
C16E		39 pf	MT		500 v		281-517
C21		100 pf	Cer.		350 v		281-523
C36		.0033 μf	Discap		500 v	5%	283-041
C44		0.2 μf	Discap		25 v		283-026
C56	101-799	.001 μf	Discap		500 v		283-000
C56	800-up	.001 μf	Discap		100 v	5%	283-065
C60		.01 μf	Discap		150 v		283-003
C64		2 x 10 μf	EMT		150 v		290-008
C67		330 pf	Cer.		500 v	10%	281-546
C68		330 pf	Cer.		500 v	10%	281-546
C75	101-799	47 pf	Cer.		500 v	10%	281-519
C75	800-up	10 pf	Cer.		500 v	10%	281-504
C76	101-799X	.02 μf	Discap		150 v		283-004
C77		0.7-3 pf		Var.			281-027
C80	101-799X	470 μf	Discap		500 v	5%	283-032
C87	101-799X	.0022 μf	Discap		50 v		283-028
C88	X800-up	150 pf	Cer.		500 v		281-524
C603		.0015 pf	Cer.		500 v		281-559
C604		.0015 pf	Cer.		500 v		281-559
C610A		40 μf	EMC		450 v		Use 290-0013-00
C610B		40 μf					
C621		0.1 μf	Discap		500 v		283-008
C625		100 μf	EMT		25 v		290-137

Inductors

LRC40		2.2 μh , 47 Ω , 39 $\mu \mu f$					*108-203
L85	X800-up	1.1 μh					*108-215
L87	101-799	Toroid, TD31					*120-202
L87	800-up	Toroid, 1T					*108-297

Fuse

		Tektronix Part Number
F601	0.4 Amp 3 AG Slo-Blo 117 v oper. 50 and 60 cycle	159-031
F601	0.2 Amp 3 AG Slo-Blo 234 v oper. 50 and 60 cycle	159-044

Resistors

Resistors are fixed, composition, $\pm 10\%$ unless otherwise indicated.

R10		27 k	1 w		5%	Use 303-273
R12		39 k	1/2 w		5%	301-393
R14		2 x 500 k		Var.	REPETITION RATE	311-152
R16		39 k			5%	301-393
R18		10 k	2 w		5%	Use 305-103
R21		200 Ω	1/2 w		5%	301-201
R31		390 Ω	1/2 w		5%	301-391
R33		200 Ω		Var.	TRIG. SENS. ADJUST	311-004
R36	101-240	Selected (nominal value 7.5 k	5%)			Use 301-103
R36	241-up	Selected (nominal value 10 k	5%)			301-103
R44		10 Ω	1/2 w			302-100
R51		500 Ω		Var.	Max. Delay	311-066
R53		300 Ω		Var.	VARIABLE	311-052
R54		500 Ω		Var.	Min. Delay	311-066
R56	101-799	8.2 k	1/2 w			302-822
	800-up	4.7 k	1 w			304-472
R60		470 Ω	1/2 w			302-471
R62		200 Ω	1/2 w		5%	301-201
R64		3.9 k	1/2 w			302-392
R66		22 k	2 w			306-223
R67		15 Ω	1/2 w			302-150
R68		15 Ω	1/2 w			302-150
R75	101-799	1 k	1/2 w			302-102
R75	800-up	1 k	1 w		5%	303-102
R77	101-799X	10 Ω	1/2 w			302-100
R78	101-799X	10 Ω	1/2 w			302-100
R80	101-240X	4.7 k	1/2 w			302-472
R81	101-240	10 k	1/2 w			302-103
R81	241-799X	6.8 k	1/2 w			302-682
R82	X800-up	51 Ω	1/4 w		5%	315-510
R83	X800-up	180 Ω	1/4 w		5%	315-181
R84		5.6 k	1/2 w		5%	Use 301-562
R85	X800-up	Selected (nominal value 82 Ω ,	5%)			315-0820-00
R86	X800-up	10 k	1/4 w		5%	315-103
R87		Selected 39-100 Ω				
R88	X800-up	10 k	1/4 w		5%	315-103
R89	X800-up	100 Ω	1/4 w		5%	315-101
R610		10 Ω	1/2 w			302-100
R614		2 k	20 w		WW 5%	308-031
R615		2 k	20 w		WW 5%	308-031
R621	101-799	2 k	5 w		WW 5%	308-003
R621	800-up	667 Ω	5 w		WW 5%	308-271
R622		2 k		Var.	AVALANCHE ADJUST	311-008
R623	101-799	1 k	2 w			306-102
R623	800-up	2 k	3 w		WW 5%	308-291

Switches

				Tektronix Part Number	
				Wired	Unwired
SW15		Rotary	RANGE	*262-357	*260-343
SW40		Rotary	FIXED INCREMENT	*262-358	*260-342
SW84	101-799	Rotary	OUTPUT POLARITY	Use *050-216	*260-342
SW84	800-up	Rotary	OUTPUT POLARITY	*262-675	260-342
SW601		Toggle	POWER ON		260-134

Transformers

T21		Toroid	TD18		*120-178
T40		Toroid	TD19		*120-179
T60	101-799	Toroid	TD20		*120-180
T60	800-up	Toroid	4T Bifilar		*120-347
T78	101-879X	Ferrite Core			276-520
T84	101-799	Toroid	TD25		*120-191
T84	800-up	Toroid	5T		*120-348
T601		LV Power			*120-182
T603		AC Line Filter			*120-164

Diodes

Even though the diodes may be different in physical size, they are direct electrical replacements for the diodes in your instrument.

D21		Germanium Tek Spec		Use	*152-0075-00
D23		Germanium Tek Spec		Use	*152-0075-00
D33		Germanium Tek Spec		Use	*152-0075-00
D53		Germanium Tek Spec		Use	*152-0075-00
D60		Germanium Tek Spec		Use	*152-0075-00
D62		Germanium Tek Spec		Use	*152-0075-00
D63		Germanium Tek Spec		Use	*152-0075-00
D64		Germanium Tek Spec		Use	*152-0075-00
D80	X241-799	Germanium Tek Spec		Use	*152-0075-00
D80	800-879	Tek GaAs			*152-161
D80	880-up	Tek GaAs			*152-184
D86	X800-up	Silicon 1N3605			152-141
D87	X800-up	Germanium HD1841			152-079
D612A,B,C,D		Silicon Replaceable by 1N2864		Use	*152-048
D624		Zener 6 V, RT6			152-016
D625		Zener 1N3024B 15 V, 1 W, 5%			152-024

Transistors

Q40		SM-04/2N695			151-032
Q60		Selected from 2N964		Use	*151-083
Q84	101-799	Selected from 2N636			*151-049
	800-up	Silicon Avalanche, checked		Use	*153-0542-00

Electron Tubes

V15		6DJ8			154-187
V619		OA2			154-001

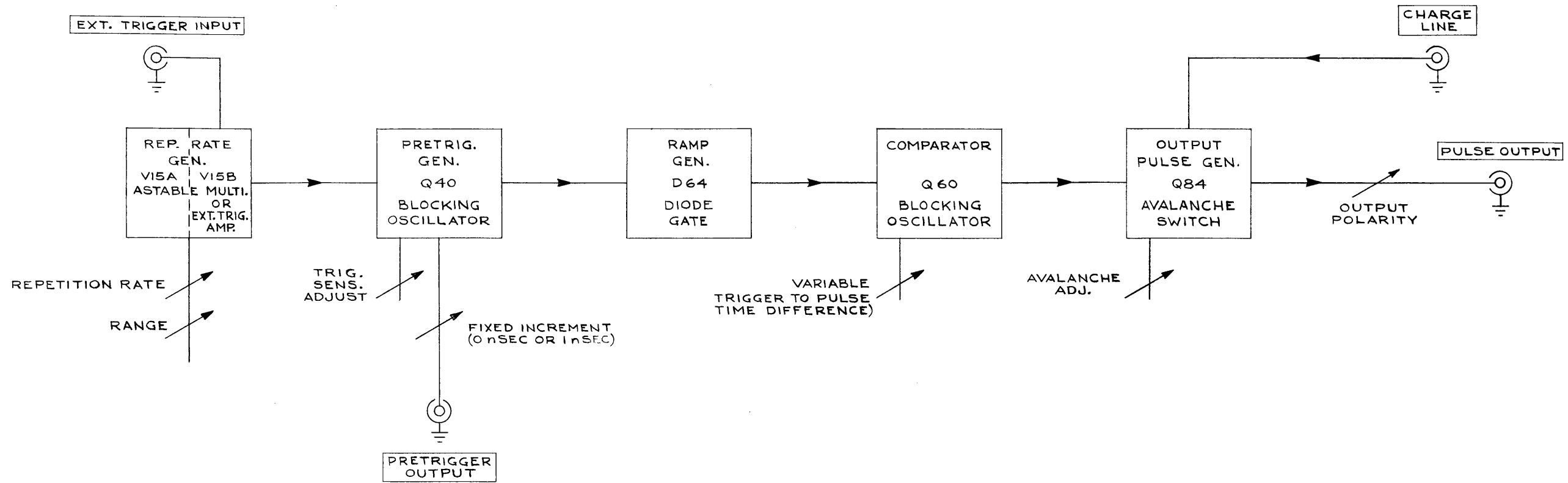

TYPE III

A₁

MRH
1-20-61
BLOCK DIAGRAM

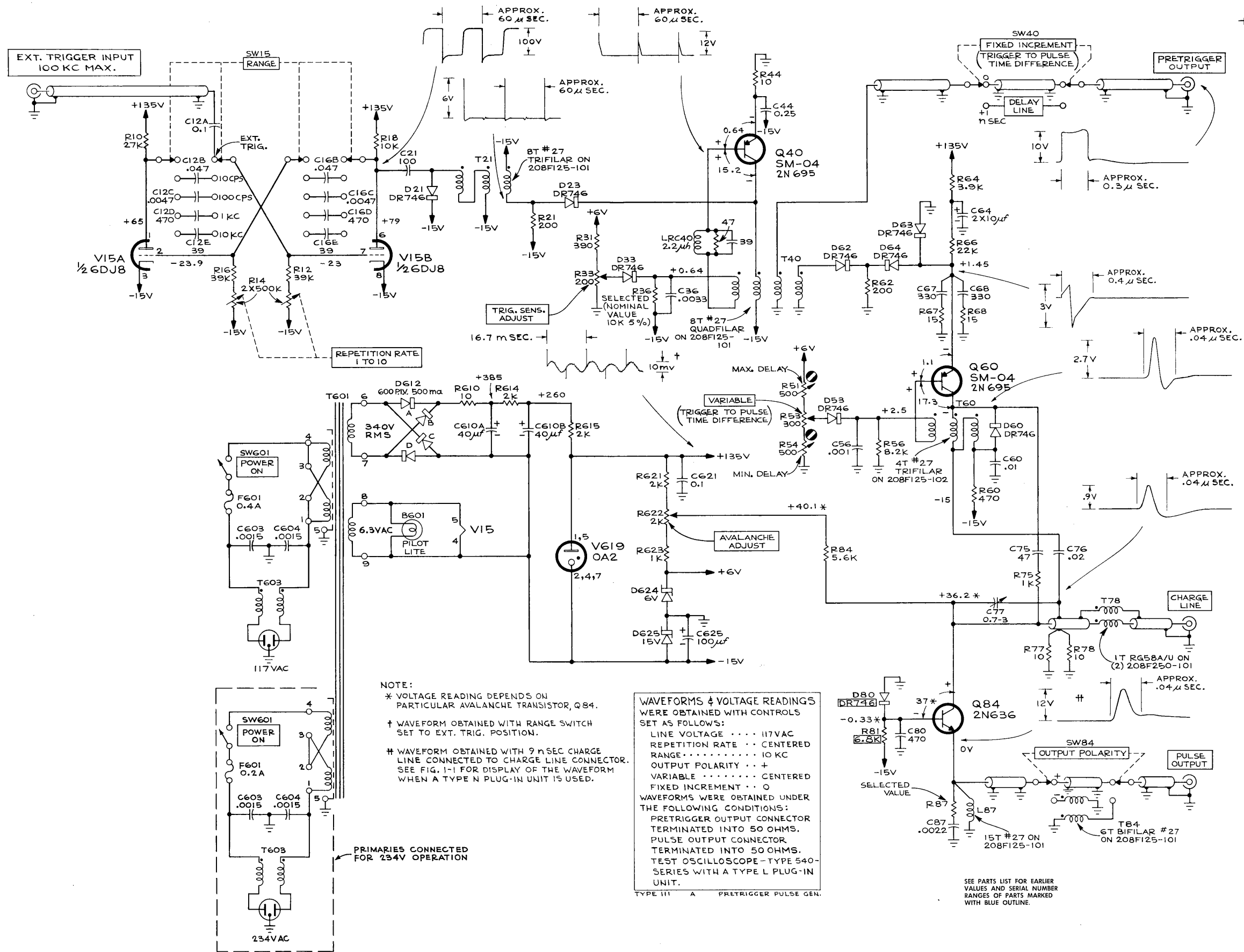

TYPE III

B

PRETRIGGER PULSE GENERATOR
S/N 101-799

PULSE GENERATOR

TR 964

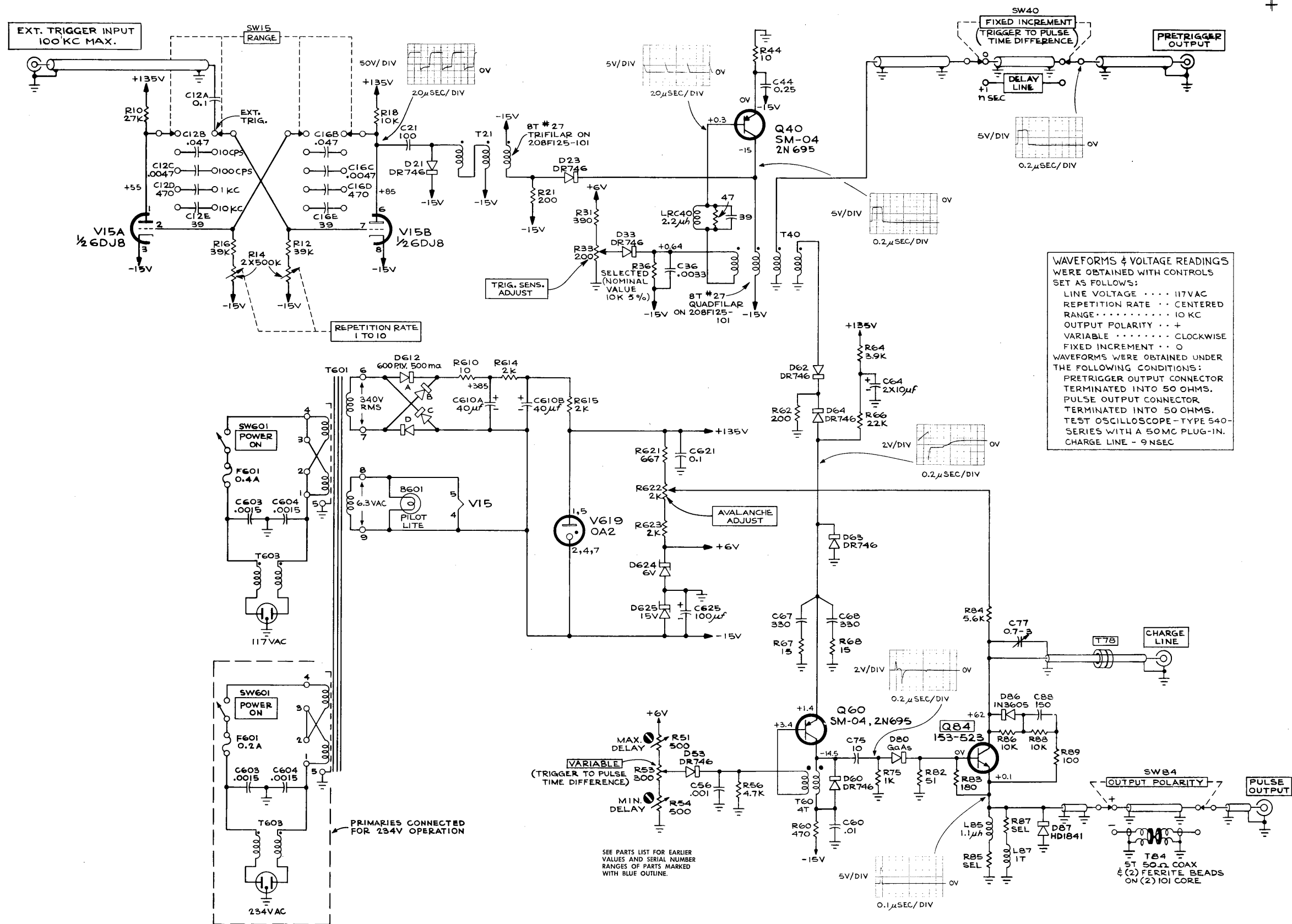

WAVEFORMS & VOLTAGE READINGS WERE OBTAINED WITH CONTROLS SET AS FOLLOWS:

- LINE VOLTAGE 117VAC
- REPETITION RATE CENTERED
- RANGE 10 KC
- OUTPUT POLARITY +
- VARIABLE CLOCKWISE
- FIXED INCREMENT 0

WAVEFORMS WERE OBTAINED UNDER THE FOLLOWING CONDITIONS:

- PRETRIGGER OUTPUT CONNECTOR TERMINATED INTO 50 OHMS.
- PULSE OUTPUT CONNECTOR TERMINATED INTO 50 OHMS.
- TEST OSCILLOSCOPE - TYPE 540-SERIES WITH A 50MC PLUG-IN.
- CHARGE LINE - 9NSEC

SEE PARTS LIST FOR EARLIER VALUES AND SERIAL NUMBER RANGES OF PARTS MARKED WITH BLUE OUTLINE.

TYPE III

TR 366
PULSE GENERATOR
S/N 800-UP

PULSE GENERATOR

MANUAL CHANGE INFORMATION

At Tektronix, we continually strive to keep up with latest electronic developments by adding circuit and component improvements to our instruments as soon as they are developed and tested.

Sometimes, due to printing and shipping requirements, we can't get these changes immediately into printed manuals. Hence, your manual may contain new change information on following pages. If it does not, your manual is correct as printed.

TYPE 111

TEXT CORRECTION

Section 5 Calibration

Page 5-2 Figure 5-1

CHANGE: Part number for C₁ to read (290-177).

TYPE 111

TENT SN 1310

PARTS LIST CORRECTION

CHANGE TO:

D682A

D682B

D682C

D682D



152-0040-00

Silicon 1N2615

STANDARD ACCESSORIES

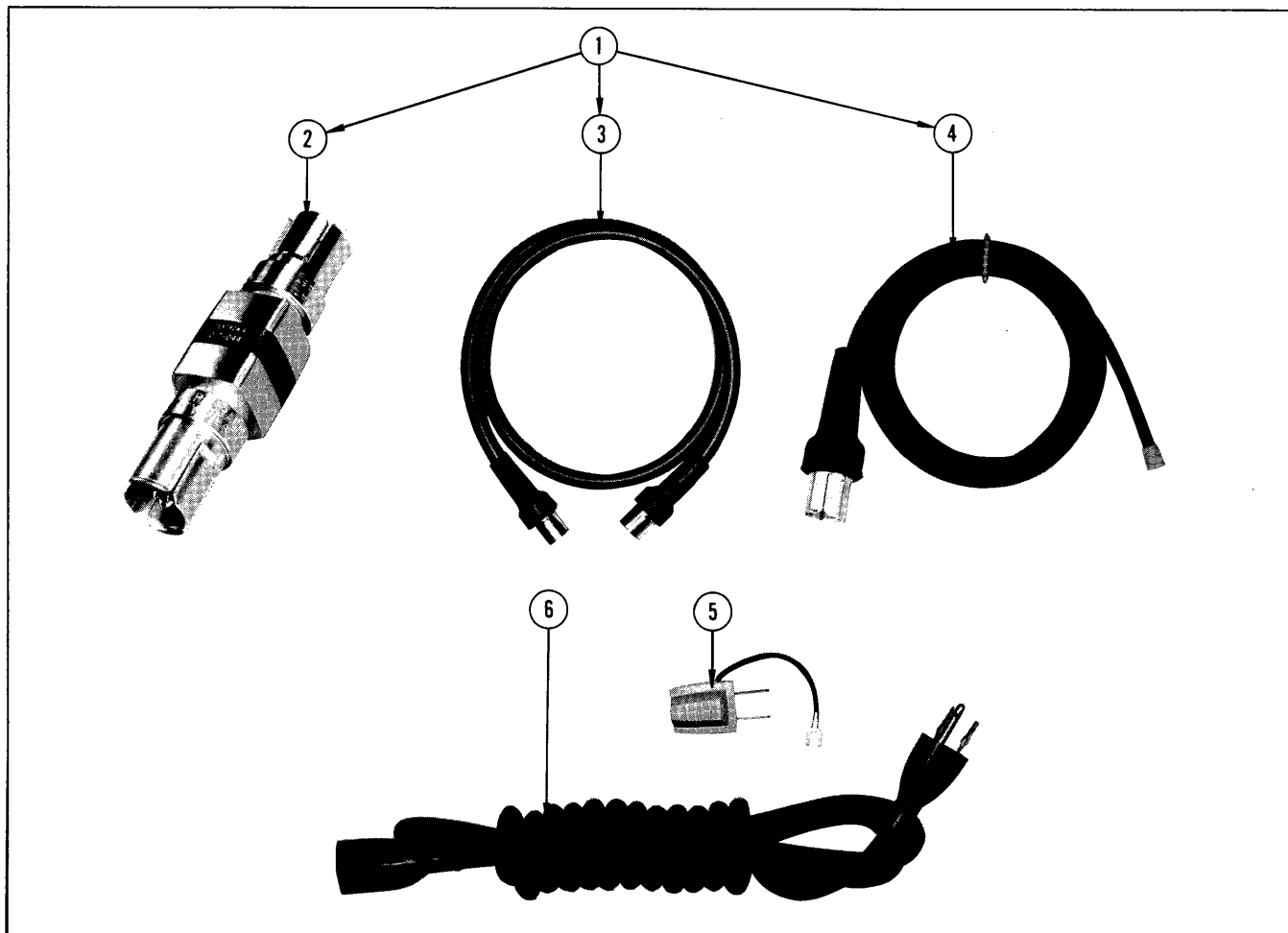

REF. NO.	PART NO.	SERIAL/MODEL NO.		QTY.	DESCRIPTION
		EFF.	DISC.		
1	020-0003-00 - - - - -			1	ACCESSORIES PACKAGE
2	017-0001-00 017-0044-00	101 450	449	1 1	Package includes: ATTENUATOR, 50 Ω, 10 x ATTENUATOR, 50 Ω, 10 x
3	017-0502-00	X360		1	CABLE, 50 Ω, 5 nsec
4	017-0506-00			1	CABLE, 50 Ω, 9 nsec
5	103-0013-00			1	ADAPTER, power cord
6	161-0010-00			1	CORD, power
- -	070-0252-00			2	MANUAL, instruction