

# SERVICETEKNOTES

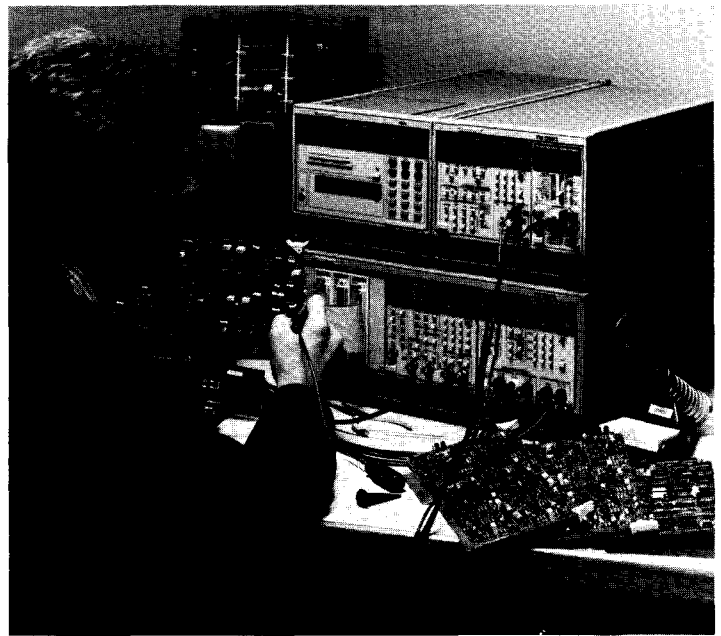
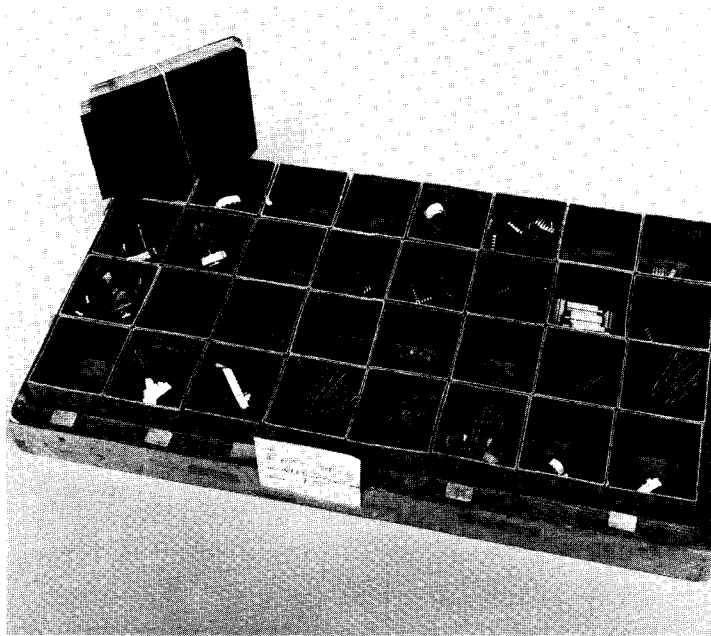
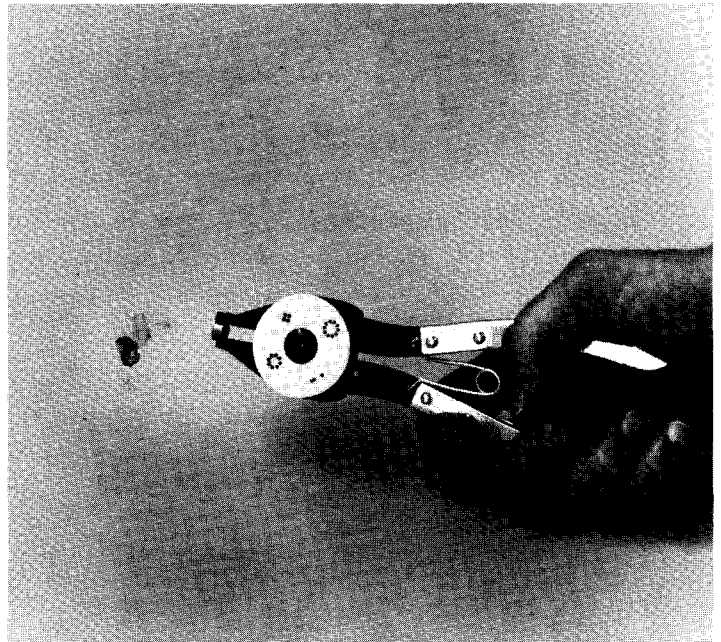
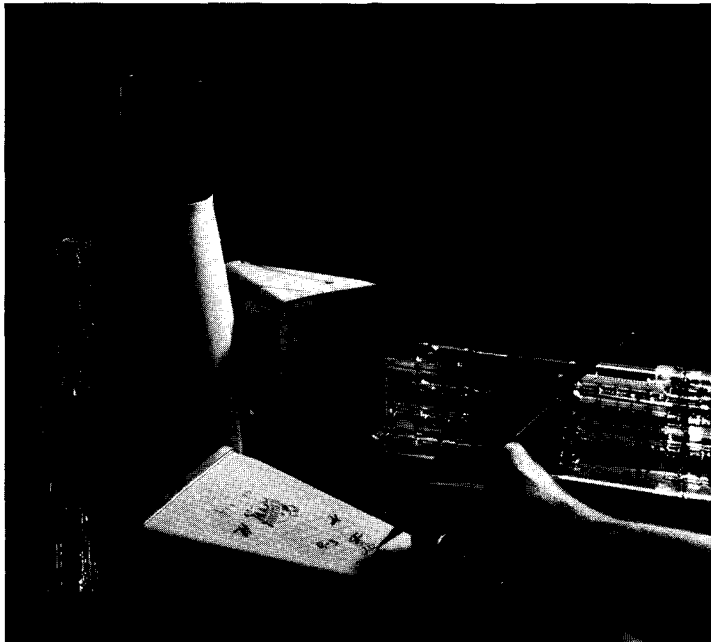

TABLE OF CONTENTS

NEW PUBLICATION SCHEDULE. . . . . 1  
SI5010 FIRMWARE BUG/SOLUTION. . . . . 1  
380/381 INSULATING TAPE, S311 . . . . . 1  
463X MOTOR BRUSH HOLDER CHANGE. . . . . 1  
464/466 NEW AND IMPROVED OSCILLOSCOPE . . . . . 2  
602 CRT NUMBERS CHANGE. . . . . 2  
690SR HORIZONTAL INSTABILITY. . . . . 3  
1240 - B04 SERVICE MANUAL ADDENDUM AVAILABLE. . . . . 4  
4115B/GMA304 DIGITAL CONVERGENCE BOARD CONNECTOR J60 FALLS OFF. . . . . 4  
4631/4632 GUIDE COMPATIBILITY IN EARLY PRODUCTS . . . . . 4

NEW PUBLICATION SCHEDULE

Service Teknotes is now going to be published on a quarterly basis. The new publication schedule will be November, February, May & August.

--Editor

SI5010 FIRMWARE BUG/SOLUTION

It has been brought to our attention that the 'USER ON/USER OFF' command once set ('USER ON') cannot be reset ('USER OFF') by the 'INIT' command. The only way to reset this is to send 'USER OFF' or cycle power.

A manual change and reference guide change has been implemented and will be distributed.

W2 Issue 14-12

380/381 INSULATING TAPE, S311

RE: 380 Manual, 070-3421-00  
381 Manual, 070-3422-00  
PICN #35

A recent inquiry from a field service technician brought out a problem in the 380/381 Test Monitors, and has resulted in a modification for correcting the fault.

The symptoms were:

- No vertical position control in AUX mode, but it had vertical position control in VECTOR mode.
- No display in AUX or VECTOR mode.

The problem was a ground at Q602's collector (schematic 6) caused by the leads on the back of the Main Board, A1, cutting through the tape on S311, A2.

Sony/Tek has instituted a change (1PICN #35) to this insulating tape to specify a better material for this application.

The new tape is P/N 342-0718-00, which is a polycarbonate tape of about 10mm x 28mm.

Replace the older tape with the new material as necessary to repair the problem, or as desired to prevent a call-back.

W2 Issue 14-13

463X MOTOR BRUSH HOLDER CHANGE

REF: 4631 Service Manual,  
P/N 070-1831-02  
4632 Service Manual,  
P/N 070-1686-04  
4634 Instruction Manual,  
P/N 070-3636-00  
4635 01, 02 Instruction Manual,  
P/N 061-2830-01  
4635 05 Instruction Manual,  
P/N 061-2831-01

The 147-0039-0X motor is used in the 4631, 4632, 4634 and 4635 copiers, imagers and recorders. The vendor who supplies these motors has recently changed the design of the brush holders. Early brush holders were machined from red plastic-covered brass slugs. The newer holders are made of black molded plastic and have a square brass insert which acts as the brush guide.

A problem has been seen on some of these new holders. The cap may bottom out within the holder before the hook-shaped terminal is secured (see figure 1). This poor connection may result in erratic motor speed and random cutter actuation. While tightening the cap to secure the terminal, the overzealous specialist (ARTICLE CONTINUED ON THE NEXT PAGE)

463X MOTOR BRUSH HOLDER CHANGE (CONT.)

may break the cap, shear off the top of the holder or rotate the holder. If the holder is rotated, damage will occur on power up as the brush cuts into the armature.

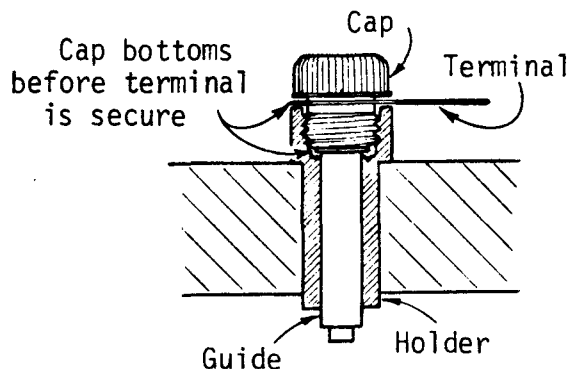

Figure 1.

The vendor is remedying the problem by using a shorter cap and recessing the brass guide. The field may wish to shim the brush cap using a 210-0012-00 lock washer (see figure 2). This will be necessary as some "defective" motors were shipped prior to discovery of the problem. Lot codes that are particularly suspect are HW, JW, KW and LW.

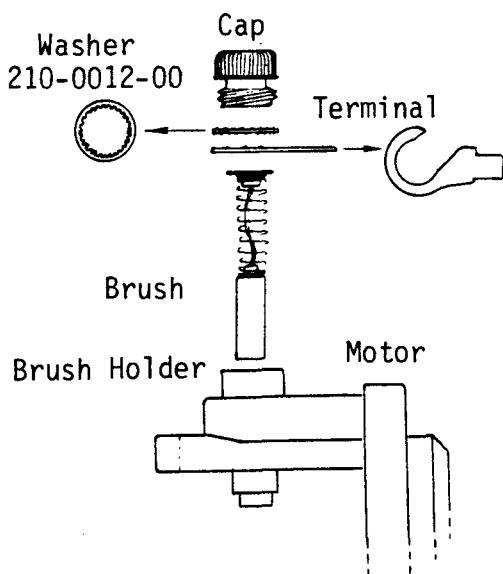

Figure 2.

464/466 NEW AND IMPROVED OSCILLOSCOPE

SN: B20XXXX and Up

Beginning AP501, a new and improved version of the 464 and 466 Oscilloscope is being shipped from the factory. Following is a list of the improvements.

1. Completely re-designed trigger board incorporating Emitter Coupled Logic in place of Tunnel Diodes. (The new trigger board is almost identical to the 468 trigger board).
2. Option 10 is now standard. Option 10 consisted of a pre-amplifier and vertical mode switch board that functioned like the 465B oscilloscope vertical section.
3. All incandescent bulbs on the front panel (including volts/division scale factors lights) have been replaced with LED's.

For instruments from Serial Number B200XXXX the 466 Service Manual P/N is 070-4796-00; for the 464 the P/N is 070-4795-00.

W2 Issue 14-13

602 CRT NUMBERS CHANGE

REF: 602 Instruction Manual,  
070-0799-00  
602 Custom Mod Manuals

Many 602 custom modified CRTs have changed in part numbers to ease ordering. These numbers are given below:

(ARTICLE CONTINUED ON THE NEXT PAGE)

602 CRT NUMBERS CHANGE (CONT.)

<u>Product</u>	<u>Tube Type</u>	<u>Old Number</u>	<u>New Number</u>
602 174K (Opt 2)	T6020-31-5	037-4027-00	154-0572-00
602 174K	T6020-7.5	037-4027-07	154-0572-01
602 174K	T6020-11-5	037-4027-11	154-0572-04
602 174K	T6020-4-5	037-4027-04	037-4082-00
602 172Z	T6020-31-w/o	037-4036-00	154-0756-00
--	--	037-4065-00	154-0816-00
602 174V	T6020-31-9.43	037-4075-00	154-0727-00
602 172V	T6020-31-9.38	037-4076-00	154-0819-00
602 174V (Opt 5)	T6020-31-9.56	037-4103-00	154-0727-00
602 717N	T6020-31-w/o	037-4108-00	154-0753-00
602 717N	T6020-11-w/o	037-4108-04	154-0753-04
602 717N	T6020-4-w/o	037-4108-94	Not Available
602 740E	T6020-31-w/o	037-4126-00	154-0754-00
602 740E	T6020-11-w/o	037-4126-11	154-0754-04
602 DE	T6020-31-9.69	037-4130-00	154-0821-00

Tube type numbers describe the primary product for which the tube is made, the phosphor used and the type of graticule. For example, the T6020-31-9.43 describes a tube made for the 602 (T6020) with P31 phosphor (31) and an internal vectorscope graticule lacking the I and Q lines (-0.43)\*. Some of the other graticule codes are:

- 1 - 8cm x 10cm crosshatch
- 5 - 8cm x 10cm border, only
- 9.17 - 5 x 10 Division graticule with line numbering
- 9.56 - Vectorscope with I and Q lines

\*Please note this correction to the illustration in the microfiche for the 602 mod 174V.

W2 Issue 14-13

690SR HORIZONTAL INSTABILITY

REF: 690SR Instruction Manual  
P/N 070-3821-00

690SR Opt. 40, 48 Instruction Manual, P/N 070-2870-00

A small amount of horizontal instability may be due to the point on the timing ramp at which VR335 conducts to cause retrace (see schematic 9) vs. H Retrace signal time coming from U215.

To prevent this instability, VR315 has been made selectable with a selection range of from 3.9 volts to 4.3 volts. This circuit sets the reference voltage on U321A and guarantees that the ramp that is generated by U332 will be sampled during ramp time and not while VR 335 is turned on.

The nominal value for VR315 will be approximately 3.9 (P/N 152-0689-00).

W2 Issue 14-12

1240 - B04 SERVICE MANUAL ADDENDUM  
AVAILABLE

Affected 1240's: Serial Numbers  
B040100 - B049999

A Service Manual Addendum is now available which documents verification/adjustment procedures and schematics which are unique to 1240's with Serial Numbers B04XXXX. Its part number is 070-4982-00.

W2 Issue 14-14

4115B/GMA304 DIGITAL CONVERGENCE BOARD  
CONNECTOR J60 FALLS OFF

Ref: GMA304/4115B Display Service  
Manual, P/N 070-4668-01

There has been a number of reports of J60 on the digital convergence board being loose or falling off after shipment. When J60 is disconnected, the auto convergence circuitry is disabled. It was found that excessive glue on the underside of the top cover, above J60, may catch and loosen or unplug that connector when the cover is installed.

If necessary, trim glue to 1/8-inch thickness.

W2 Issue 14-14

4631/4632 GUIDE COMPATIBILITY IN  
EARLY PRODUCTS

Ref: 4631 Service Manual, 070-1831-02  
4632 Service Manual, 070-1686-04

When replacing processors in the 4631 and 4632 hard copy units, it is important to compare the lengths of the

fishline paper guides between the old and new processors. If an earlier, shorter chrome guide (P/N 351-0378-00) is being replaced by a newer, longer black guide (P/N 351-0582-00), two problems are possible.

First, if the baffle in the top cover rubs against the fishline guide, eventual breakage of the fishline will result. Second, when the cover is closed to set the switch panel height for no light leaks, the baffle may catch under the new, longer paper guide. The cover may now be locked in place and not removed without damage to either the baffle, the paper guide, or both.

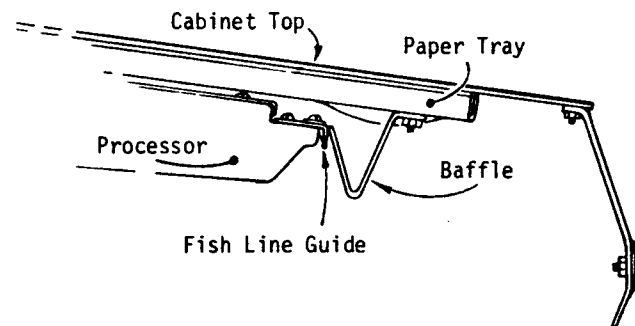

Figure 1

The solution is to use caution when closing the cover on a new processor for the first time. With the switch panel lowered to present the worst case, slowly lower the cabinet top. At the first hint of binding between the paper guide and the baffle, the cover should be raised and the baffle bent slightly to prevent interference. Continue in this manner until it is certain that the baffle and paper guide won't interfere. Then, set the switch panel for the correct height.

W2 Issue 14-13

The Tektronix Service Organization firmly supports a policy of assuring continued utility of products sold by Tektronix.

This publication is meant to provide technical information to the customer who has decided to maintain his own Tektronix products. It contains product servicing information and is written for the technician.

Articles are submitted primarily by Corporate Service Support & Planning Personnel thoroughly familiar with the products they support. SERVICE TEKNOTES also encourages you to submit articles for publication. If you have knowledge of a technique, procedure or idea that enables you to service your Tektronix product more effectively, write it down so others may benefit from your experience.

Articles for publication should be submitted directly to:

Tektronix, Inc.  
P.O. Box 500  
Beaverton, Oregon 97077

Attention: Janet Hemenway  
SERVICE TEKNOTES Editor

Delivery Station: 53-037

SERVICE TEKNOTES is distributed by Service Administrative Support free of charge to customers who maintain their own Tektronix equipment. A customer may be added to the distribution list by applying through his local Tektronix Sales Engineer.

---

Copyright ©1981, Tektronix, Inc. All rights reserved. Printed in U.S.A. Tektronix products are covered by U.S. and foreign patents, issued and pending. Information in this publication supersedes that in all previously published material. Specification and price change privileges reserved. TEKTRONIX, TEK, SCOPE-MOBILE, and  are registered trademarks of Tektronix, Inc. TELEQUIPMENT is a registered trademark of Tektronix U.K. Limited.

---

The Editor and staff of SERVICE TEKNOTES provide the material in this publication as a service to users of Tektronix Products. While we have tried to be diligent in assuring the accuracy of the material which we have printed, we cannot guarantee its accuracy. Neither SERVICE TEKNOTES, its editor and staff, Tektronix, Inc., nor its representatives assume any responsibility for the use of the material printed in SERVICE TEKNOTES; nor can we assume any responsibility for any errors or for the resulting effects of any errors.