

3

MATERIALS

COMMON DESIGN PARTS CATALOG

COMPANY CONFIDENTIAL

MAY 1982

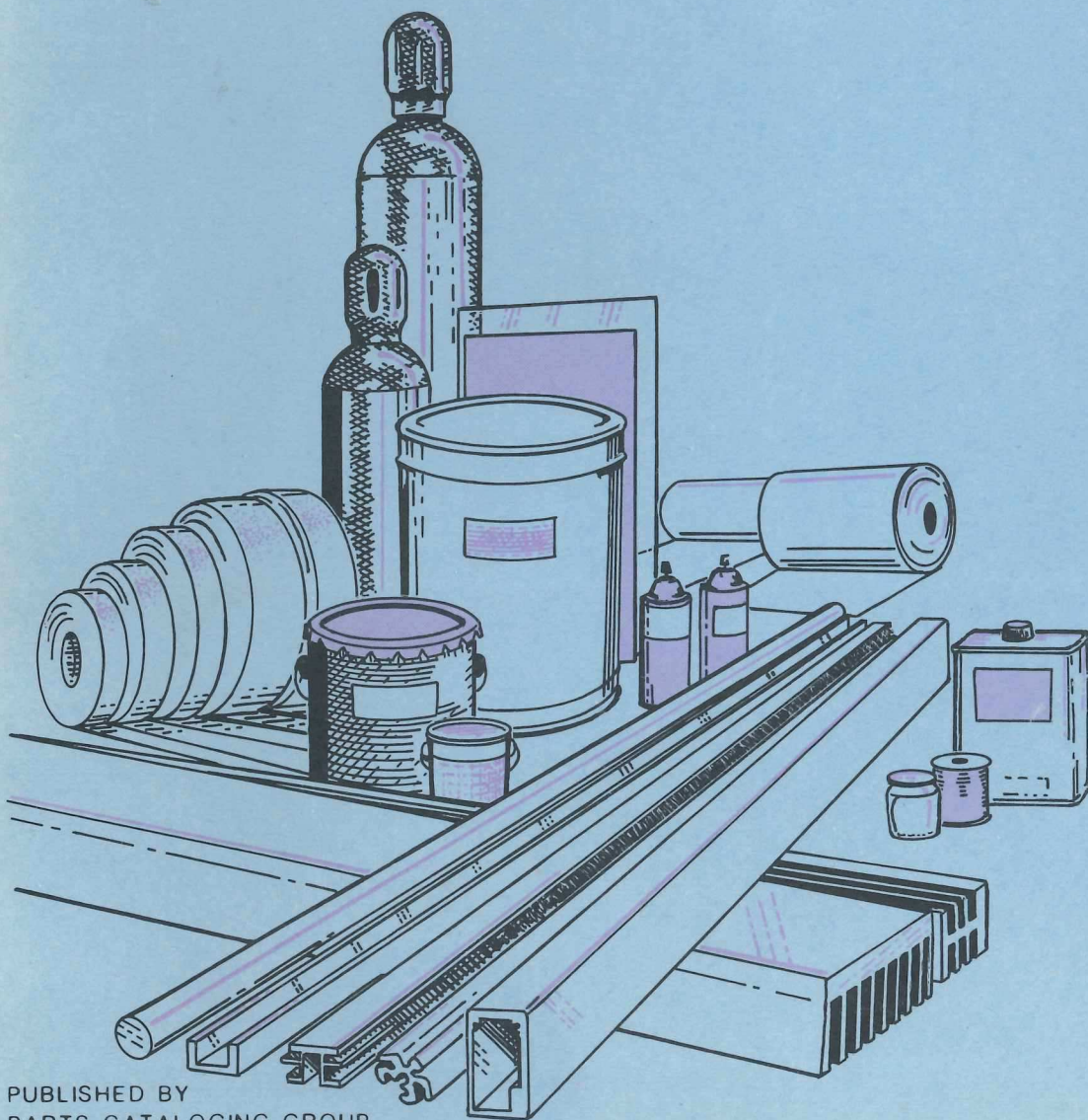

PUBLISHED BY
PARTS CATALOGING GROUP
(78-567 ext 2591 DR)

Tektronix
COMMITTED TO EXCELLENCE

TEK PN SYSTEM STATUS CODES MATERIALS CAT PN INDEX	0
PLASTIC MOLDING MATERIALS	1
PLASTIC: SHAPES & SHEETS ELEC INSUL MATL FELT	2
CKT BD MATERIAL EPOXY PREFORMS CERAMIC SUBSTRATES	3
TAPE & ADHESIVES INDUSTRIAL GAS CERAMIC MOLDING MATERIALS	4
PAINT, ETC COATINGS SOLVENTS LUBRICANTS	5
ALUMINUM EXTRUSIONS	6
ALUMINUM: WIRE, BAR, FLAT, TUBE	7
BRASS	8
COPPER - BERYLLIUM	9
PHOSPHOR - BRONZE	10
COPPER	11
MISC METALS PRECIOUS METALS FRONT PANELS SOLDER & FLUX	12
MAGNETIC SHIELDING	13
STEEL	14
STAINLESS STEEL	15

COMPANY CONFIDENTIAL

THE CONTENTS OF THIS CATALOG ARE FOR THE EXCLUSIVE USE OF TEKTRONIX EMPLOYEES. ANY UNAUTHORIZED USE MAY CONSTITUTE A THEFT.

PURPOSE AND USE

This catalog is not intended to be a specification document by including all characteristics of the parts listed. It is a catalog with parts arranged in an order determined by the prime characteristic.

Parts not listed herein are either not to be used in new design or are so new that their characteristics may yet be changed. We suggest you call the appropriate Component Engineer and/or check the component specification for complete details on any part before making a decision on its use. Specifications can be obtained from Reprographics 58-038, ext. 1658, or viewed at any of the satellite aperture card locations.

CORRECTIONS & SUGGESTIONS

Corrections or suggestions are encouraged at any time. Call ext. 2585 or mail to delivery station 78-567. Special forms for this purpose are also included at the front of the catalog.

UPDATES AND NOTES

We have included pages throughout the catalog entitled UPDATES AND NOTES for your use.

HOW TO ORDER CATALOGS

Call ext. 2591 or write to Parts Cataloging, 78-567. We will need your name, payroll code, delivery station and responsibility-cost center.

USING CATALOGS FOR PARTS REPLACEMENT

No effort has been made to correlate the parts in this catalog with those parts which are available for replacement in the field. Some of the parts listed herein are not available for use as replacement parts. Ordering such parts will only slow your order and impede the general efficiency of the parts ordering process. All replacement parts are listed in the NPR (Numerical Parts Record).

COST CODE

(CC COLUMN)

CODE	≈ VALUE with -	≈ VALUE no suffix	≈ VALUE with +
A	.2¢	.5¢	.75¢
B	1.25¢	1.5¢	2¢
C	2.5¢	3¢	3.75¢
D	4.25¢	5¢	6¢
E	7¢	8¢	10¢
F	13¢	15¢	18¢
G	22¢	25¢	35¢
H	40¢	50¢	60¢
I	65¢	75¢	\$1
J	\$1.25	\$1.50	\$2
K	\$2.50	\$3	\$3.75
L	\$4.25	\$5	\$6
M	\$7	\$8	\$10
N	\$13	\$15	\$18
O	\$22	\$25	\$35+

NOTE: Costs may vary from order to order due to order quantities, vendor, etc.

NEW FEATURES IN THIS CATALOG

Hand Tools, Small

Conversion Table (Inch to mm)

NOTICE: The Insulators & Heat Sinks Section has been removed from this catalog and will appear in the Semiconductor (#1) only.

CATALOG DISTRIBUTION NOT AUTOMATIC

We have special routing lists to announce new catalogs. A response to those notices is necessary each time to receive the next edition of a catalog. Call ext. 2591 to have your name added to the mailing list.

PARTS INFORMATION (WHERE TO LOCATE - HOW TO DO)

- BILL OF MATERIALS - Component Item Sequence Report (#400-02) - 55-139 or ext. 3584.
- BUYER for a part is ? - See inside back cover or call ext. 2727.
- BUYER NUMBER:
 1. For a given part number - Use IMS - IMINQRT2.
 2. General reference - See inside back cover or call ext. 2727.
- CENTRAL STORES PARTS - 71-555 or call ext. 4182.
- COMPONENT ENGINEER for a part is ? - See pages 0-70 through 0-73.
- COMPONENT INFORMATION SYSTEM (CIS) - Available on CYBER B Machine.
 1. On-line queries and data entry of purchased component information.
 2. Printed reports of purchased component information.
 3. Call CISDG at Ext's. 2520, 2583 or 2587 for more information.
- COMPONENT RELIABILITY INFORMATION SERVICES - 53-114, ext. 8006-MR.
- COMPONENT NEWS (publication) - Call ext. 1762 or write to 58-122 for copies.
- COMPONENT RELIABILITY - Call ext. 1605, 58-061.
- COST:
 1. Of a part - Ext. 3246, 55-640.
 2. Of an instrument - Ext. 3246, 55-640.
 3. How a cost was arrived at - Ext. 3246, 55-640.
- DESCRIPTION OF A PART (in Item Master) - Call ext. 2220.
- ENVIRONMENTAL TEST LAB (I.D.) - Call ext. 4788, 50-132.
- ENVIRONMENTAL TEST LAB (I.D.D.) - Call ext. 3987-W, 63-076.
- NETTING REPORT (requirements) - Call ext. 3268.
- NPR (Numerical Parts Record) - Parts Research, ext. 2156, 73-848.
- PARTS RESEARCH (Customer Service) - 73-848, ext. 2156.
- PPL (Parts Price List) - Parts Research, ext. 1951, 73-275.
- PPRL (Parts Price & Replacement List) - Parts Research, ext. 1951, 73-275.
- PRODUCT FAILURE EXPERIENCE - Call ext. 8006-MR, 53-114.
- RESERVES on a part - Call ext. 3268.
- SALVAGE: (Further questions call ext. 8346-Y6 or 8345-Y6)
 1. Paper and old catalogs - Send to 02-172.
 2. Chemicals with precious metals - 10-000.
 3. Precious metals bearing scrap - 68-000.
(There is a precious metals transfer form available - #000-8855-00)
- SOURCES on a purchased part:
 1. PISL (purch. item source list) - Attached to each part specification.
 2. PISL on-line on the Component Information System on CYBER B Machine (see CIS above). Users manual for CIS is available from 78-584.
 3. Buyer - See inside back cover or call ext. 2741.
- SPECIFICATION DOCUMENT for a part:
 1. Aperture card file and viewer-printer:
 - a. Reprographics, 58-038, ext. 1658 (generally same day service, 24 hours)
 - b. Buildings 19, 39, 50, 63, 78 and 92.
 2. Aperture card file and viewer only:
 - a. Buildings 02, 19, 51, 53, 55, 58, 60, 70, 73 and 94.
- STATUS of a part - IMS - IMINQRT2
- To order A NEW PURCHASED PART:
 1. For trial use: Special purchase requisition (form #000-1165-00).
 2. For permanent use: PPIF (form #000-1704-00) to 78-584.
- To order PARTS FROM STOCK - Refer to Materials Ordering & Planning Process Manual.
- To order PRINTED FORMS - Use Requisition Review Log Sheets, form #000-5930-00 and send it to 70-697, ext. 4166.
- To order TEK INSTRUMENT MANUALS:
 1. From the field - Use TEKNET.
 2. Internal - Use Requisition Review Log Sheet #000-5930-00 and process it like a part order.
(NOTE: Manuals cannot be ordered by instrument number, call ext. 2208 to get manual numbers.)
- To order TEK PRODUCT CATALOGS - 76-131 or ext. 2248.
- To order THESE CATALOGS - Ext. 2591, 78-567. We will need your name, payroll code, delivery station, ext. and responsibility-cost center before issuing a catalog.
- To order UNNUMBERED PARTS SAMPLES - Special purch. req. to engineering buyer.
- UNNUMBERED PARTS & WHO HAS THEM - Check with eng. buyer or comp. eval. engineer.
- VENDOR COMPONENT CATALOGS - 78-567, ext. 2591.
- WHERE A PART IS USED (instrument or kit):
 1. Call ext. 2200 or stop by 78-608.
 2. Use bill of materials (component item sequence portion).
 3. First used on - Call ext. 2220.

SEND OUTDATED CATALOGS TO SALVAGE, 02-001.

PURCHASED PART INITIATION FORM

The PPIF is shown below. The form was revised to add spaces for safety requirements, and space to list second source.

Please salvage the old forms and order new ones from the warehouse (P/N 000-1704-00).

ORIGINATOR - Fill as completely as possible. Attach two copies of manufacturer's data sheet or 2 Tek drawings. In the event of a mod, a copy of the mod proposal. Send all six copies of the PPIF and attachments to Documentation Coordination, 78-584.

C.E. - Documentation Coordinator (ext. 2586 & 2578) will assign parts coordination number for tracking. C.E. Engineer will complete this section.

BASE DATA MGT. DEPT. - Assigns Tek part number and description.

FIRST PARTS DISTRIBUTION - Used to reserve stock for mod. If a new part in new instrument, Engineering Stock parts may be set up.

PURCHASING - Completed at time of initial purchase order.

PURCHASED PART INITIATION FORM FOR TEK PN

ORIGINATOR		(Date) _____ (Engineer) _____ (Phone) _____ (del sta) _____	(Date) _____ (Project Engineer) _____ (Phone) _____	DATE NEEDED <small>not for A & B phase</small>	
		(Date) _____ (Prototype Support Technician) _____ (Phone) _____ (del sta) _____	(Date) _____ MOD Coordinator _____ (Phone) _____ (del sta) _____		
		DESCRIBE PART NEEDED, ATTACH 2 COPIES OF UPDATED MFG DATA SHEET OR TEK DWG.			
		ITEM NAME _____ DESCRIPTION: _____			
		Safety Controlled Component Yes _____ No _____		BUYER CONTACT _____	
		Standard Mfg. Catalog Part Yes _____ No _____	Tek Drawing or Data Sheet Yes _____ No _____	Part has Tek Supplied Subparts Yes _____ No _____ IF YES, ATTACH TEK SUPPLIED PARTS LIST	
		MANUFACTURER _____ MFG'S P/N: _____			
		MANUFACTURER _____ MFG'S P/N: _____			
		PROJECT/MOD NO.	INSTRUMENT	QTY/INSTR	INSTR PER 1ST YEAR

Directions: Use typewriter or ball point pen. Press firmly to mark all copies.

COMPONENT EVALUATION		DESCRIPTION: _____		
		COMMENTS: _____		
		SUPPLIER NAME AND PART NUMBER	INITIAL COST EST.	SOURCE RATING†

		†A=approved N=not approved Q=qualifying E=emergency		
		This part (has) (has not) been evaluated Part for _____		Spec. Required Yes _____ No _____
		Anticipated Buyer No. _____	Engr Stock Yes _____ No _____	
		(Date) _____ (Component Evaluation Engineer) _____ (Phone) _____ (del sta) _____	Parts Coordinator No. _____	

BASE DATA MGT DEPT		ITEM MASTER NAME: _____
		DESCRIPTION: _____

FIRST PARTS DISTRIBUTION		NAME	DEL STA	WHEN NEEDED	ACCOUNT NUMBER	QUANTITY
		TOTAL ORDER QUANTITY _____				

PURCH		DATE DUE _____ STOCK UNIT _____	ORDER NO. _____
		MATERIAL CLASS _____	INITIAL COST ESTIMATE _____
		(Date) _____ (Buyer) _____ (No) _____ (Phone) _____	Lead Time _____ (in working days)

000-1704-00
Revised April 1980

 **Tektronix, Inc.**

1. White-Purchasing	4. Goldenrod-Prototype Support Tech
2. Green-Component Specifications	5. White-Purchasing
3. Canary-Component Evaluation Engr	6. Pink-Engineer

WHAT IS THE COMPONENT INFORMATION SYSTEM?

The Component Information System, CIS, is a computerized database system which acts as a centralized source of information on purchased components. CIS contains the following types of services: on-line data entry by the originators of the data, on-line queries by any CYBER B computer user using a user-friendly interactive program, and standard and customized reports on lists of parts supplied by the user. The database currently contains information on 59,000 purchased and 7,000 Tek-manufactured components. Most of the information contained in the system is related to "fitness for use". CIS now contains information on purchased part descriptions, buyers, costs, controlling documents, official sources for parts, Component Engineering and Reliability Engineering comments on purchased parts, Product Safety generated information about safety-controlled parts, and parametric information (only for memories at this time). By the end of year 200 CIS will contain information on purchased part documentation (currently existing in Dorothy Smith's Documentation Coordination System).

Call Jim Sasser (ext. 2587) to schedule a 45 minute presentation on CIS or to schedule a training session on use of the on-line program.

EIA DATE CODE

EIA DATE CODE

What and why:

The production lot date of many, if not most of our purchased electrical parts are identified by using the EIA date code system. In other words, the EIA date code is used to identify the date of production for a part.

How does the date code work?

The last two digits of the production year plus the number of the week of that year are used. A hypothetical example of the use of the EIA date code would be: two digits for the year - such as "82" and another two digits for the week of the year. Thus, the date code might be: 8206 which would represent "82" for 1982, the production year, and "06" for the week of February 4-10, the production week. (The first week of the year is that calendar week in which the first Thursday falls.)

If a component manufacturer is unable to use the four-digit date code, an alternate three-digit code may be used by taking only the last digit of the year. The above example would then become: 206.

**User
Feedback**

We want this to be the FINEST - MOST USEFUL printing you have ever seen. If we have slipped-up and you feel there is room for improvement, please tell us at once. You will be doing us a great favor if you call a problem to our attention.

Your Name _____ Address _____ Phone _____

ERRORS, OMISSIONS, SUGGESTIONS:

SUGGESTIONS

SEND TO DOROTHY SMITH
78-567

**User
Feedback**

We want this to be the FINEST - MOST USEFUL printing you have ever seen. If we have slipped-up and you feel there is room for improvement, please tell us at once. You will be doing us a great favor if you call a problem to our attention.

Your Name _____ Address _____ Phone _____

ERRORS, OMISSIONS, SUGGESTIONS:

SUGGESTIONS

SEND TO DOROTHY SMITH
78-567

**User
Feedback**

We want this to be the FINEST - MOST USEFUL printing you have ever seen. If we have slipped-up and you feel there is room for improvement, please tell us at once. You will be doing us a great favor if you call a problem to our attention.

Your Name _____ Address _____ Phone _____

ERRORS, OMISSIONS, SUGGESTIONS:

SUGGESTIONS

SEND TO DOROTHY SMITH

78-567

**User
Feedback**

We want this to be the FINEST - MOST USEFUL printing you have ever seen. If we have slipped-up and you feel there is room for improvement, please tell us at once. You will be doing us a great favor if you call a problem to our attention.

Your Name _____ Address _____ Phone _____

ERRORS, OMISSIONS, SUGGESTIONS:

SUGGESTIONS

SEND TO DOROTHY SMITH

78-567

**User
Feedback**

We want this to be the FINEST - MOST USEFUL printing you have ever seen. If we have slipped-up and you feel there is room for improvement, please tell us at once. You will be doing us a great favor if you call a problem to our attention.

Your Name _____ Address _____ Phone _____

ERRORS, OMISSIONS, SUGGESTIONS:

SUGGESTIONS

SEND TO DOROTHY SMITH

78-567

**User
Feedback**

We want this to be the FINEST - MOST USEFUL printing you have ever seen. If we have slipped-up and you feel there is room for improvement, please tell us at once. You will be doing us a great favor if you call a problem to our attention.

Your Name _____ Address _____ Phone _____

ERRORS, OMISSIONS, SUGGESTIONS:

SUGGESTIONS

SEND TO DOROTHY SMITH

78-567

**User
Feedback**

We want this to be the FINEST - MOST USEFUL printing you have ever seen. If we have slipped-up and you feel there is room for improvement, please tell us at once. You will be doing us a great favor if you call a problem to our attention.

Your Name _____ Address _____ Phone _____

ERRORS, OMISSIONS, SUGGESTIONS:

SUGGESTIONS

SEND TO DOROTHY SMITH
78-567

**User
Feedback**

We want this to be the FINEST - MOST USEFUL printing you have ever seen. If we have slipped-up and you feel there is room for improvement, please tell us at once. You will be doing us a great favor if you call a problem to our attention.

Your Name _____ Address _____ Phone _____

ERRORS, OMISSIONS, SUGGESTIONS:

SUGGESTIONS

SEND TO DOROTHY SMITH
78-567

PLASTIC MOLDING MATERIAL

SECTION 1

TABLE OF CONTENTS

	PAGE(S)
TRADEMARKS AND TRADENAMES	1-2 & 1-3
ASTM PLASTICS ABBREVIATIONS	1-4
ACETAL	1-5
ACRYLIC	1-6
ACRYLONITRILE-BUTADIENE-STYRENE (ABS)	1-7 THRU 1-9
CELLULOSE ACETATE BUTYRATE (CAB)	1-9
FLUOROCARBON (TFE)	1-10 & 1-11
METHYLPENTENE POLYMER	1-12
PHENOLIC	1-13
POLYALLOMER	1-14
POLYAMIDE (NYLON)	1-14 THRU 1-17
POLYCARBONATE (PC)	1-18 THRU 1-20
POLYETHYLENE (PE)	1-21 THRU 1-23
POLYPHENYLENE OXIDE (PPO)	1-24
POLYPHENYLENE SULFIDE (PPS)	1-25
POLYPROPYLENE (PP)	1-26 & 1-27
POLYSTYRENE (PS)	1-28 & 1-29
POLYSULFONE	1-30
POLYURETHANE (PUR)	1-31 THRU 1-33
RUBBER	1-33
SILICONE (SI)	1-34 & 1-35
VINYL (PVC)	1-36 THRU 1-38
EPOXY	1-38
PIGMENT, COLOR CONCENTRATES & OTHER ADDITIVES	1-39
NOTES	1-40
CROSS REFERENCE INDEX	1-41 THRU 1-43
UL INFORMATION	1-44
CONDUCTIVE ELASTOMER SELECTION GUIDE	1-45 THRU 1-48

PLASTIC MOLDING MATERIAL (CONT)

REGISTERED TRADEMARKS AND TRADENAMES USED IN THIS CATALOG FOR PLASTICS

1

<u>GENERIC NAME</u>	<u>TRADENAME</u>	<u>MANUFACTURER</u>
ACETAL	FULTON THERMOCOMP	Liquid Nitrogen Processing Corporation Liquid Nitrogen Processing Corporation
ACETAL RESIN	CELCON DELTRIN REED	Celanese Plastics Company E. I. duPont de Nemours and Company, Inc. Reed Plastics
ACRYLIC	DYNEL IMPLEX LUCITE PLEXIGLAS POLOROID	Rohm and Haas Company E. I. duPont de Nemours and Company, Inc. Rohm and Haas Company Polaroid Corporation
ACRYLONITRILE-BUTADIENE-STYRENE	BAYBLEND CYCOLAC CYCOLOY THERMOCOMP	Fiberchem, Inc. Borg-Warner Corporation Borg-Warner Corporation Liquid Nitrogen Processing Corporation
ARAMID FIBER	KEVLAR	E. I. duPont de Nemours and Company, Inc.
CELLULOSE-ACETATE-BUTYRATE	TENITE	Eastman Kodak Company
CHLOROSULFONATED POLYETHYLENE	HYPALM	
DIALLYL PHTHALATE	DIALL	Mesa Plastics Company
EPOXY	HYSOL MORTON CHEMICAL POLYSET	The Dexter Corporation Morton Chemical
EPOXY RESIN	ECCOSORB EPON ESSEX STACAST	Emerson & Cuming, Inc. Emerson & Cuming, Inc.
FLUOROCARBON	HALAR TEFLON TEFZEL	Allied Chemical Corporation E. I. duPont de Nemours and Company, Inc. E. I. duPont de Nemours and Company, Inc.
METHYLPENTENE POLYMER	TPX	ICI America, Inc.
MICRO-GLASS FIBER REINFOR.	RT DUROID	Rogers Corporation
*NYLON (POLYAMIDE)	CAPRON NYLAFIL NYLAGLAS NYLASAR NYLATRON PLASKON THERMOCOMP TRADLON WELL-A-MELD ZYTEL	Allied Chemical Corporation Fiberfil, Inc. Fiberfil, Inc. Fiberfil, Inc. The Polymer Corporation Allied Chemical Corporation Liquid Nitrogen Processing Corporation Nichols and Company, Inc. E. I. duPont de Nemours and Company, Inc.
PHENOLIC	FIBERITE ROGERS	Fiberite Corporation Rogers Corporation
POLYALLOMER	TENITE	Eastman Kodak Company
POLYCARBONATE	LEXAN MERLON REED THERMOCOMP	General Electric Company Mobay Chemical Company Reed Plastics Liquid Nitrogen Processing Corporation
POLYESTER	BMC DACRON MYLAR PREMIGLAS VIBRAMAT	W. R. Grace Company E. I. duPont de Nemours and Company, Inc. Premix, Inc. W. R. Grace Company
POLYETHYLENE	AVECOR BAKELITE ETHYLENE-HEXENE MARLEX TENITE ULTRATHENE	Eastman Chemical Products, Inc. Union Carbide Corporation E. I. duPont de Nemours and Company, Inc. Phillips Chemical Company Eastman Kodak Company U. S. I. Chemical Company
POLYIMIDE	KAPTON	E. I. duPont de Nemours and Company, Inc.
POLYPHENYLENE OXIDE	NORYL	General Electric Company
POLYPHENYLENE SULFIDE	RYTON THERMOCOMP	Phillips Chemical Company Liquid Nitrogen Processing Corporation

*NYLON IS NOT A TRADENAME BUT A GENERIC TERM FOR A CLASS OF POLYAMIDES.

PLASTIC MOLDING MATERIAL (CONT)

REGISTERED TRADEMARKS AND TRADENAMES USED IN THIS CATALOG FOR PLASTICS (CONT)

<u>GENERIC NAME</u>	<u>TRADENAME</u>	<u>MANUFACTURER</u>
POLYPROPYLENE	OLEFORM PRO-FAX TENITE	Amoco Chemicals Corporation Hercules Powder Company, Inc. Eastman Kodak Company
POLYSTYRENE	AMOCO DYLITE LUSTREX STYRAFIL THERMOCOMP	Amoco Chemicals Corporation Koppers Company, Inc. Monsanto Chemical Company Fiberfil, Inc. Liquid Nitrogen Processing Corporation
POLYSULFONE	BAKELITE THERMOCOMP UDEL	Union Carbide Corporation Liquid Nitrogen Processing Corporation Union Carbide Corporation
POLYTETRAFLUOROETHYLENE	RT DUROID	Rogers Corporation
POLYURETHANE	ADIPRENE ESTANE ROYLAR STAFOAM THERMOCOMP NOPCO	E. I. duPont de Nemours and Company, Inc. B. F. Goodrich Company Uniroyal, Inc. American Latex Product Corporation Liquid Nitrogen Processing Corporation Nopco Chemical Company
POLYVINYL CHLORIDE (VINYL)	GEON MANNER TEKNOR-APEX	B. F. Goodrich Company Manner Plastics Materials, Inc. H. M. Royal, Inc.
POLYVINYL FLUORIDE	KYNAR HALAR TEDLAR	Pennwalt Corporation Allied Chemical Corporation E. I. duPont de Nemours and Company, Inc.
RUBBER	KRATON TPR	Shell Chemical Company Uniroyal, Inc.
SILICONE RUBBER	ECCOSIL HYPALON SILASTIC	Emerson & Cuming, Inc. Liquid Nitrogen Processing Corporation Dow Corning Corporation

1

PLASTIC MOLDING MATERIAL (CONT)

USE OF ABBREVIATIONS (AS STATED IN ASTM D1600)

When abbreviations are used in publications or other written matter, their first occurrence in the text should be enclosed in parentheses and preceded by the written word or words being abbreviated. Subsequent references to such words in the article can then be by the appropriate abbreviations, as such.

These abbreviations may not be included in Tek Standard 062-1737-00, MIL STD-12C or ANSI Y1-1.

ABBREVIATIONS

PLASTICS AND RESINS	
TERM	ABBREVIATION
Acrylonitrile - butadiene - styrene plastics	ABS
Carboxymethyl cellulose	CMC
Casein	CS
Cellulose acetate	CA
Cellulose acetate-butyrate	CAB
Cellulose acetate propionate	CAP
Cellulose nitrate	CN
Cellulose propionate	CP
Chlorinated poly (vinyl chloride)	CPVC
Chlorotri fluorethylene	CTFE
Cresol-formaldehyde	CF
Diallyl phthalate	DAP
Epoxy, epoxide	EP
Ethyl cellulose	EC
Ethylene-propylene-dieneterpolymer	EPDM
Expanded polystyrene	EPS
Melamine-formaldehyde	MF
Perfluoro (ethylene-propylene) copolymer	FEP
Phenol-formaldehyde	PF
Poly (acrylic acid)	PAA
Polyacrylonitrile	PAN
Polyamide (nylon)	PA
Polybutadiene-acrylonitrile	PBAN
Polybutadiene-styrene	PBS
Polycarbonate	PC
Polychlor-alkine (derivative of PVC)	PCA
Poly (diallyl phthalate)	PDAP
Polyester	PBT/BET
Polyethylene	PE
Polyethylene terephthalate	PETP
Poly (methyl-a-chloracrylate)	PMCA
Poly (methyl methacrylate)	PMMA
Polymonochlorotrifluoroethylene	PCTFE
Polyoxymethylene, polyacetal	POM
Polyphenylene oxide	PPO
Polyphenylene sulfide	PPS
Polypropylene	PP
Polystyrene	PS
Polytetrafluoroethylene	PTFE
Polyurethane	PUR
Polyvinyl acetate	PVAC
Polyvinyl alcohol	PVAL
Polyvinyl butyral	PVB
Polyvinyl chloride	PVC
Polyvinyl chloride-acetate	PVCA
Polyvinyl fluoride	PVF
Polyvinyl formal	PVFM
Polyvinylidene fluoride	PVDF/PVF ₂
Silicone plastics	SI
Styrene-acrylonitrile	SAN
Styrene-butadiene	SB
Styrene-rubber plastics	SRP
Urea-formaldehyde	UF

PLASTIC AND RESIN ADDITIVES	
TERM	ABBREVIATION
Dibutyl phthalate	DBP
Dicapryl phthalate	DCP
Diisodecyl adipate	DIDA
Diisodecyl phthalate	DIDP
Diisooctyl adipate	DIOA
Diisooctyl phthalate	DIOP
Dinonyl phthalate	DNP
Di-n-octyl n-decyl phthalate	DNODP
Diocetyl adipate	DOA
Diocetyl azelate	DOZ
Diocetyl phthalate	DOP
Diocetyl sebacate	DOS
Diphenyl cresyl phosphate	DPCF
Diphenyl 2-ethylhexyl phosphate	DPOF
Fluorocarbon	TFE
Trichloroethyl phosphate	TCEF
Tricresyl phosphate	TCF
Triocetyl phosphate	TOF
Triphenyl phosphate	TPP

MONOMERS	
TERM	ABBREVIATION
Diallyl chlorendate (diallyl ester of 1, 4, 5, 6, 7, 7-hexachlorobicyclo-(2,2,1)-5-heptene-2, 3-dicarboxylic acid)	DAC
Diallyl fu marate	DAF
Diallyl isophthalate	DAIP
Diallyl maleate	DAM
Diallyl orthophthalate	DAP
Methyl methacrylate	MMA
Monochlorotrifluoroethylene	CTFE
Tetrafluoroethylene	TFE
Triallyl cyanurate	TAC

PLASTIC MOLDING MATERIAL (CONT)

ACETAL

DESCRIPTION		REMARKS	PART NUMBER	CC	
MATERIAL	COLOR			LB	CU IN
Celcon C-244	Charcoal Gray CC-3277	High Flow	255-0160-00	J+	E-
Celcon C-244	Tek Blue CG 3282	High Flow	255-0173-00	J+	E
Celcon C-244	Smoke Tan	High Flow	255-0173-01	J+	E
Celcon C-244	Earth Brown	High Flow	255-0173-02	J+	E
Celcon C-244	Slate Gray	High Flow	255-0173-03	J+	E
Celcon C-244	Natural CF2001		255-0180-00	A- gr	
Delrin 500	Natural 10	Medium Flow	254-0998-00	J-	D
Delrin 500	Black 602	Medium Flow	255-0010-00	J	D+
Delrin 500	Medium Gray 602	Medium Flow	255-0014-00	J	D+
Delrin 500	Brown 603	Medium Flow	255-0090-00	J-	D+
Delrin 500	Medium Gray 634	Medium Flow	255-0109-00	K-	D+
Delrin 500	Medium to Dark Gray 714	Medium Flow	255-0227-00	J+	E
Delrin 500	Green 602	Medium Flow	255-0228-00	I+	D
Delrin 500	Turquoise Blue 604	Medium Flow	255-0229-00	J	D+
Delrin 500	Beige 601	Medium Flow	255-0230-00	J	D+
Delrin 500	Yellow 603	Medium Flow	255-0231-00	J-	D+
Delrin 500	Orange 602	Medium Flow	255-0233-00	K	F
Delrin 500 AF	Brown	Medium Flow, 20% Teflon Fiber	255-0320-00	L	G
Delrin 570 X	Natural 000	20% Glass Filled	255-0240-00	J	D+
Delrin 577	Black 000	Medium, 20% Glass Filled	255-0207-00	J+	E
Delrin 900	Red 601	High Flow	255-0189-00	J-	D+
Delrin 900	Black 602	High Flow	255-0190-00	J	D+
Delrin 900	Natural 10	High Flow	255-0197-00	I+	D-
Delrin 900	White 602	High Flow	255-0217-00	J	D+
Delrin 900	Silver Gray 754	High Flow	255-0285-00	J+	E
Fulton 404	Natural	20% Teflon Particle Filled	255-0469-00	K	F
Thermocomp KFX-1004	Medium Gray 0-015	20% Glass Filled	255-0214-00	J+	E

PROPERTIES	UNIT OF MEASURE	CELCON C-244	DELRIN 500	DELRIN 500AF	DELRIN 570X DELRIN 577	DELRIN 900	FULTON 404	THERMOCOMP KF-1004	ASTM TEST METHOD
PHYSICAL PROPERTY									
Specific Gravity	in/in	1.410	1.425	1.540	1.560	1.425	1.550	1.540	D792
Mold Shrinkage		.020	.020-.030		.013	.020-.030	.017	.006	D955
Melting Point	°F	329	347			347			
Water Absorption, 24 hrs.	%	.220	.250	.060	.250	.250	.150	.350	D570
MECHANICAL PROPERTY									
Tensile Strength, yield	psi	8,800	10,000	6,900	8,500	10,000	10,000	12,500	D638
Elongation	%	60	15	12	7	13	7	2.500	D638
Tensile Modulus	psi	410,000	415,000		880,000	410,000	390,000	16,500	D638
Flexural Strength	psi		14,000			14,000	10,000		D790
Flexural Modulus	psi	375,000	415,000						D790
Impact Strength, Notched Izod	ft.lb/in	1.200	1.400	.700	.800	1.300	.600	.800	D256
Hardness, Rockwell		M80	M94, R120	M78, R118	M90, R118	M94, R120	M60	M85	D785
THERMAL PROPERTY									
Linear Thermal Expansion	in/in/°F	4.7 x 10 ⁻⁵	4.5 x 10 ⁻⁵	4.5 x 10 ⁻⁵	2.-4.5 x 10 ⁻⁵	4.5 x 10 ⁻⁵	5.4 x 10 ⁻⁵	2.9 x 10 ⁻⁵	D696
Deflection Temperature at 66 psi	°F	316	338	329	345	338	320	330	D648
at 264 psi	°F	230	255	212	315	255	210	325	
ELECTRICAL PROPERTY									
Dielectric Strength, Short Time	V/mil	500	500			500			D149
Dielectric Constant									D150
at 10 ³ Hz		3.700	3.700			3.700			
at 10 ⁶ Hz		3.700	3.700			3.700			
Dissipation Factor									D150
at 10 ³ Hz		.001	.003			.003			
at 10 ⁶ Hz		.006	.004			.003			
UL INFORMATION Δ								NOT UL RECOGNIZED	
Min. Material Thickness		.062 .12 .24	.12 .24	.058 .12	.058 .12	.058 .12 .24	.062		
Flammability Rating UL94		HB HB HB	HB HB	HB HB	HB HB	HB HB HB	HB		
Hot Wire Ignition		8 8 20	16 41	7 31	7 31	15 16 41			
High Amp Arc Ignition		100+100+100+	200+200+	122 200+	142 200+	200+200+200+			
High Volt Track Rate		0.0 0.0 0.0	0.1 0.1	0.1 0.2	0.2 0.2	0.0 0.1 0.1			
Solvent Resistance: Excellent resistance to all organic solvents; unsatisfactory for continued exposure to some acids and alkalis.									

⊗ = Not recommended for new design.

⊕ = Preferred

Δ See Page 1-44 for definitions of UL terms used in Section 1.

PLASTIC MOLDING MATERIAL (CONT)

ACRYLIC

DESCRIPTION		REMARKS	PART NUMBER	CC	
MATERIAL	COLOR			LB	CU IN
Plexiglas V	Green 940	Optical Grade	255-0174-00	K+	F
Plexiglas V (811)	Colorless 100	Optical Grade	255-0099-00	I	C
Plexiglas VS	White IG 647-70	Optical Grade	255-0318-00	H+	C-
Plexiglas VS	Colorless 100	Optical Grade	255-0385-00	K+	F
Plexiglas VS	Blue 48143	Optical Grade	255-0446-00	J	D+
MODIFIED					
DESCRIPTION		REMARKS	PART NUMBER	CC	
MATERIAL	COLOR			LB	CU IN
Implex B	Black 6011	Rubber, modified	255-0061-00	H+	B+
PROPERTIES	UNIT OF MEASURE	PLEXIGLAS V and V(811) ²	PLEXIGLAS VS ¹	IMPLEX B ³	ASTM TEST METHOD
PHYSICAL PROPERTY Specific Gravity Mold Shrinkage Water Absorption, 24 hrs.	in/in % %	1.190 .004 .300	1.180 .004 .300	1.150 .006 .200	D792 D955 D570
MECHANICAL PROPERTY Tensile Strength, yield Elongation Tensile Modulus Flexural Strength Impact Strength, Notched Izod Hardness, Rockwell	psi % psi psi ft.lb/in. M95	10,400 6.000 430,000 No Break .250	8,600 3.500 380,000 14,000 .250	5,900 30. 320,000 No Break .800	D638 D638 D638 D790 D256 D785
THERMAL PROPERTY Linear Thermal Expansion Deflection Temperature at 66 psi at 264 psi	in/in/°F °F °F	3.9×10^{-5} 214 198	4.1×10^{-5} 176 167	5.1×10^{-5} 185 174	D696 D648
ELECTRICAL PROPERTY Dielectric Strength, Short Time Dielectric Constant at 10 ³ Hz at 10 ⁶ Hz Dissipation Factor at 10 ³ Hz at 10 ⁶ Hz	V/mil 	500 3.300 2.200 .120 .060	500 3.500 2.300 .130 .080	480 3.300 2.700 .100 .010	D149 D150 D150
OPTICAL PROPERTY Refractive Index		1.490	1.490		D542
UL INFORMATION Δ Min. Material Thickness Flammability Rating UL94 Hot Wire Ignition High Amp Arc Ignition High Volt Track Rate		.058 .060 HB HB 15 14 200+ 200+ -- --	.058 .060 HB HB 15 14 200+ 200+ -- --	NOT UL RECOGNIZED	

¹Maximum flow-for applications where ease of molding is more important than heat resistance.

²High heat resistance.

³High flow, medium high impact strength.

PLASTIC MOLDING MATERIAL (CONT)

ACRYLONITRILE-BUTADIENE-STYRENE (ABS)

1

DESCRIPTION		REMARKS	PART NUMBER	CC	
MATERIAL	COLOR			LB	CU IN
Cyclocac JP	Black 4083	Expansion Grade	255-0382-00	J+	D
PROPERTIES	UNIT OF MEASURE	CYCOLAC JP	ASTM TEST METHOD		
PHYSICAL PROPERTY Specific Gravity	in/in	.800	D792 D955		
Mold Shrinkage		.007			
MECHANICAL PROPERTY Tensile Strength, yield	psi	3,200	D638 D638 D790		
Tensile Modulus	psi	250,000			
Flexural Strength	psi	4,200	D256 D1706		
Impact Strength, Notched Izod	ft.lb/in	.900			
Hardness, Rockwell		R65			
UL INFORMATION		NOT UL RECOGNIZED			

DESCRIPTION		REMARKS	PART NUMBER	CC	
MATERIAL	COLOR			LB	CU IN
Thermocomp AF 1004-EP	Natural	20% Glass Filled (Plating Grade)	255-0483-00	J+	D+
Thermocomp AF 1006	Black 8-001	30% Glass Filled	255-0271-00	J+	D+
Thermocomp AF 1008	Gray 0-083	40% Glass Filled	255-0447-00	J+	E
PROPERTIES	UNIT OF MEASURE	THERMOCOMP AF-1004-EP	THERMOCOMP AF-1006	THERMOCOMP AF-1008	ASTM TEST METHOD
PHYSICAL PROPERTY Specific Gravity	in ³ /lb	1.200	1.280	1.380	D792 D792 D955
Specific Volume		23.100	21.600	20.100	
Mold Shrinkage		.0015	.001	.001	D570 D570
.125 in Average Section		.002	.0015	.0015	
.250 in Average Section	%	.150	.140	.100	
Water Absorption, 24 hrs. To Saturation	%	.700	.600	.500	
MECHANICAL PROPERTY Tensile Strength, break	psi	13,500	14,500	20,000	D638
73°F		8,500	9,000	10,500	D638 D790 D790
140°F	%	3-4	3-4	2-3	
Elongation	psi	17,500	18,500	26,500	
Flexural Strength	psi	850,000	1,100,000	1,400,000	D695 D732-78 D256
Flexural Modulus		800,000	1,000,000	1,300,000	
73°F	psi	13,500	14,500	20,000	D696 D648
140°F		7,000	7,500	9,000	
Compressive Strength	psi	1,500	1,400	1,300	D621
Shear Strength		6-7	6-7	5-6	
Impact Strength, Izod		R124, M97	R124, M99	R124, M102	D635
Notched .250 in Bar					
Unnotched .250 in Bar	in/in/°F	2.0 x 10 ⁻⁵	1.6 x 10 ⁻⁵	1.2 x 10 ⁻⁵	
Hardness, Rockwell	°F	225	230	250	
		215	220	240	
THERMAL PROPERTY Linear Thermal Expansion	%	.400	.300	.100	
Deflection Temperature at 66 psi	in/min	S B	S B	S B	
at 264 psi					
Deformation Under Load, 24 hrs. 4000 psi, 50°C					
Flammability					
UL INFORMATION Δ					
Min. Material Thickness		.069	.069	.069	
Flammability Rating UL94		V-0	V-0	V-0	

Δ See Page 1-44 for definitions of UL terms used in Section 1.

PLASTIC MOLDING MATERIAL (CONT)

ACRYLONITRILE-BUTADIENE-STYRENE (ABS)

DESCRIPTION		REMARKS	PART NUMBER	CC		
MATERIAL	COLOR			LB	CU IN	
Cycolac EP-3510	Light to Medium Gray 3510	Plating Grade	255-0161-00	I+	C	
Cycolac GSM	Black 4500		255-0009-00	I+	C	
Cycolac GSM	Medium Gray 3727		255-0015-00	J	D	
Cycolac GSM	Appliance White 2502		255-0095-00	H	B	
Cycolac GSM	White 22071		255-0759-00	J-	D-	
Cycolac GSM	Yellow 7500		255-0220-00	J+	D+	
Cycolac GSM	Silver Gray 30765		255-0376-00	J	D	
Cycolac GSM	Blue 52168		255-0644-00	J+	D+	
Cycolac GSM	Bule 51115		255-0682-00	I+	C	
Cycolac GSM	Smoke Tan 85566		255-0644-01	J	D	
Cycolac GSM	Earth Brown 85567		255-0644-02	J	D	
Cycolac GSM	Slate Gray 32877		255-0644-03	J	D	
Cycolac GSM	Flint Gray		255-0644-04	K-	E	
Cycolac GSM	Ivory Gray		255-0644-05	K-	E	
Cycolac GSM	Dove Gray		255-0644-06	J	D	
Cycolac GSM	Spruce Green 9500		255-0811-00	K	E+	
Cycolac T	Tek Blue 50454	255-0134-00	I+	C		
Cycolac T	Orange 70314	255-0683-00	I+	C		
Cycolac T	Blue 51997	255-0693-00	J	D		
Cycolac T	TV Gray 32670	255-0701-00	I+	C		
Cycolac X-11	Red 60076	255-0219-00	J+	D+		
Cycolac X-11	Medium Gray 30950	255-0302-00	J+	D+		
Cycolac X-11	Green 90495	255-0312-00	I+	C		
Cycolac X-11	Red 6500	255-0313-00	K	E+		
Cycolac X-11	Charcoal Gray 3649	255-0081-00	I+	C		
Cycolac X-11	New Generation Gray 3807	255-0113-00	J+	D+		
PROPERTIES	UNIT OF MEASURE	CYCOLAC EP-3510	CYCOLAC GSM	CYCOLAC T	CYCOLAC X-11	ASTM TEST METHOD
PHYSICAL PROPERTY						
Specific Gravity	psi	1.070	1.040	1.040	1.040	D792
Melt Flow Index			.0070			D1238
Mold Shrinkage	in/in	.006-.008	.007	.005	.006-.008	D955
Water Absorption, 24 hrs.	%	.400	.430	.400		D570
MECHANICAL PROPERTY						
Tensile Strength, yield	psi	6,100	6,300	6,000	6,000	D638
Tensile Strength, break	psi		6,000	6,000		D638
Tensile Modulus	psi	330,000	320,000	300,000	290,000	D638
Flexural Strength	psi	10,500	10,000	9,600	9,800	D790
Flexural Modulus	psi		330,000		300,000	D790
Impact Strength, Notched Izod	ft.-lb/ft	5.300	7.000	5.300	6.500	D256
Hardness, Rockwell		R103	R102	R104	R100	D785
THERMAL PROPERTY						
Linear Thermal Expansion	in/in/°F	5.3×10^{-5}	5.28×10^{-5}	5.3×10^{-5}	5.1×10^{-5}	D696
Vicat Softening Point	°F	217	222	218		D1525
Deflection Temperature (Unannealed)						
at 66 psi	°F	206	211	209	231	
at 264 psi	°F	189	193	192	223	
ELECTRICAL PROPERTY						
Dielectric Constant						D150
at 10^3 Hz		2.910	2.810	2.910		
at 10^6 Hz		2.440	2.760	2.440		
Dissipation Factor						D150
at 10^3 Hz		.006	.007	.006		
at 10^6 Hz		.008	.010	.008		
UL INFORMATION Δ						
Min. Material Thickness		.058 .120 .240	.058 .120 .240	.058 .120 .240	.058 .120 .240	
Flammability Rating UL94		HB HB HB	HB HB HB	HB HB HB	HB HB HB	
Hot Wire Ignition		15 13 14	11 12 14	13 17 21	13 16 14	
High Amp Arc Ignition		200+ 200+ 200+	200+ 200+ 200+	200+ 200+ 200+	200+ 200+ 200+	
High Volt Track Rate		2.4 1.1 1.0	3.1 -- --	6.7 5.1 4.0	2.0 1.7 1.2	

PLASTIC MOLDING MATERIAL (CONT)

ACRYLONITRILE-BUTADIENE-STYRENE (ABS)

DESCRIPTION		REMARKS	PART NUMBER	CC	
MATERIAL	COLOR			LB	CU IN
Bayblend 6500 Bayblend 6500 Cycolac FBK Cycolac FBK Cycolac KJB Cycolac KJB Cycolac KJB	Black 1510 Slate Gray Natural Black White X88-2260 Black 4051 Silver Gray 30765	Fire Retardant Fire Retardant Fire Retardant Structural Foam Fire Retardant Structural Foam Fire Retardant Fire Retardant Fire Retardant	255-0574-00 255-0821-00 255-0767-00 255-0812-00 255-0244-00 255-0550-00 255-0755-00	J+ L- J J+ J- J- J-	E- F+ F F F
PROPERTIES	UNIT OF MEASURE	BAYBLEND 6500	CYCOLAC FBK	CYCOLAC KJB	ASTM TEST METHOD
PHYSICAL PROPERTY Specific Gravity Mold Shrinkage	in/in	1.190 .005-.007	.005-.008	1.210 .006-.008	D792-66 Method A D955
MECHANICAL PROPERTY Tensile Strength, yield Tensile Modulus Flexural Strength Flexural Modulus Impact Strength, Notched Izod Hardness, Rockwell	psi psi psi psi ft-lb/in	8,500 370,000 13,700 380,000 10.500 R117	1,900-3,900 250,000 4,200-7,800 210,000-280,000 R60-70	6,000 320,000 10,000 330,000 4.000 R97	D638-68 D638-68 D790-66 D790-66 D256-56 D785-65
THERMAL PROPERTY Linear Thermal Expansion Deflection Temperature Annealed at 66 psi Annealed at 264 psi Deflection Temperature Unannealed at 66 psi Unannealed at 264 psi	in/in/°F mil deflection °F at 10 mil deflection °F at 10	370,000 240 225 238 220	>190 >180	530,000 213 203 198 180	D696 D648-56 D648-56
UL INFORMATION Δ Min. Material Thickness Flammability Rating UL94 Hot Wire Ignition High Amp Arc Ignition High Volt Track Rate		NOT UL RECOGNIZED	.240 .360 V-0 V-0 48 73 200+ 200+ 16 13	.060 .120 .240 V-0 V-0 V-0 138 31 29 200+ 200+ 200+ 10.0 11.0 9.0	

CELLULOSE-ACETATE-BUTYRATE (CAB)

DESCRIPTION		REMARKS	PART NUMBER	CC	
MATERIAL	COLOR			LB	CU IN
Tenite 285A-MS Tentie 285A-MS Tenite 285A-MS	Red Translucent 22014 Black 15170 Dark Red Transparent	-- -- --	254-0922-00 254-0923-00 254-0938-00	I I+ I	C C+ C
PROPERTIES	UNIT OF MEASURE	TENITE 285A-MS	ASTM TEST METHOD		
PHYSICAL PROPERTY (.125 Thick) Specific Gravity Melt Flow Water Absorption, 24 hrs.	°F	1.170 284 1.300	D792 D569 D570		
MECHANICAL PROPERTY Tensile Strength, yield Tensile Strength, break Flexural Strength Stiffness in Flexure Impact Strength, Notched Izod Hardness, Rockwell	psi psi psi psi ft-lb/in	2,700 4,000 4,000 95,000 8.000 R35	D638 D639 D790 D747 D256 D785		
THERMAL PROPERTY Deflection Temperature at 66 psi at 264 psi	°F °F	150 130	D648		
UL INFORMATION Δ		NOT UL RECOGNIZED			

Solvent Resistance: Soluble in ketones and esters, softened or slightly soluble in alcohol, little affected by aliphatic hydrocarbons. Softened by chlorinated or aromatic hydrocarbons. Slightly affected by weak alkalis, decomposes in strong alkalis.

PLASTIC MOLDING MATERIAL (CONT)

FLUOROCARBON (TFE)

DESCRIPTION		REMARKS	PART NUMBER	CC	
MATERIAL	COLOR			LB	CU IN
Teflon* Teflon 100	Natural Natural	Foam (Cellular) Extrusion Grade Extrusion/Injection Grade	255-0405-00 255-0140-00	N- M	H+
PROPERTIES	UNIT OF MEASURE	TEFLON*	TEFLON 100	ASTM TEST METHOD	
PHYSICAL PROPERTY Specific Gravity Melting Point Water Absorption, 24 hrs. Weather Resistance Chemical Resistance	°F %		2.120-2.170 495-520 .010 Excellent Excellent	D2116-62T D2116-62T D570-63	
MECHANICAL PROPERTY Tensile Strength, break Elongation Flexural Modulus Hardness, Shore	psi % psi		3,000 300 95,000 D55	D2116-62T D2116-62T D790-63 D1706-61	
ELECTRICAL PROPERTY Volume Resistivity Dielectric Strength, Short Time, 10 mil Dielectric Constant Dissipation Factor (60-109 cps.)	Ω-cm V/mil 50-100 Hz		10 ¹⁸ 2,100 2.100 .0002-.0007	D257-61 D149-64 D150-64T D150-64T	
UL INFORMATION Δ Min. Material Thickness Flammability Rating			.062 V-0		

DESCRIPTION		REMARKS	PART NUMBER	CC	
MATERIAL	COLOR			LB	CU IN
Tefzel 200 Tefzel HT2004	Natural Natural	Injection/Extrusion Grade Injection Grade; 20% G655 Filled	255-0510-00 255-0771-00	I+ oz N-	I
PROPERTIES	UNIT OF MEASURE	TEFZEL 200	TEFZEL HT 2004	ASTM TEST METHOD	
PHYSICAL PROPERTY Specific Gravity Water Absorption, 24 hrs.	%	1.700 <.030	1.860 .022	D792 D570	
MECHANICAL PROPERTY Tensile Strength, break Elongation Tensile Modulus Flexural Modulus Compressive Strength Shear Strength Impact Strength, Notched Izod 73°F (23°C) Hardness Shore Rockwell	psi % psi psi psi psi ft·lb/in ft·lb/in	6,500 200 20,000 200,000 7,100 6,000 >20 No break D75	12,000 8 12,000 95,000 10,000 9 R74	D638 D638 D638 D790 D695 D732-78 D256	
THERMAL PROPERTY Thermal Conductivity Specific Heat Linear Thermal Expansion 68- 86°F 122-194°F 284-356°F Deflection Temperature at 66 psi at 264 psi Brittle Temperature Continuous Use Temperature (No Load) Deformation Under Load 2000 psi at 122°F	Btu in/hr ft ² °F Btu/lb °F in/in per °F in/in per °F in/in per °F °F °F °F °F %	1.650 5.0 x 10 ⁻⁵ 5.2 x 10 ⁻⁵ 7.6 x 10 ⁻⁵ 220 160 Below -150 302 4.110	1.660 .460-.470 1.7 x 10 ⁻⁵ 510 410 392	C177 C351 D696 D648 D746 D621	
UL INFORMATION Δ Min. Material Thickness Flammability Rating UL94 Hot Wire Ignition High Amp Arc Ignition High Volt Track Rate		.062 V-0 23 200+ 10.3	NOT UL RECOGNIZED		

PLASTIC MOLDING MATERIAL (CONT)

FLUOROCARBON (TFE)

1

DESCRIPTION		REMARKS	PART NUMBER	CC	
MATERIAL	COLOR			LB	CU IN
Halar 500	Natural		255-0782-00	N-	I
PROPERTIES	UNIT OF MEASURE	HALAR 500	ASTM TEST METHOD		
PHYSICAL PROPERTY Specific Gravity Mold Shrinkage Water Absorption, 24 hrs.	in/in %	1.680 .020-.025 <0.1	D792 D570		
MECHANICAL PROPERTY Tensile Strength, yield Tensile Strength, break Elongation Tensile Modulus Flexural Strength Flexural Modulus Impact Strength, Notched Izod Hardness, Rockwell	psi psi % psi psi psi ft-lb/in	4,500 7,000 200 240,000 70,000 240,000 No break R93	D638 D639 D638 D638 D790 D790 D256		
THERMAL PROPERTY Linear Thermal Expansion Deflection Temperature at 66 psi at 264 psi Heat Distortion at 66 psi at 264 psi	in/in/°F °F °F °F °F	8.0 x 10 ⁻⁵ 239 169 115 76	D696 D648		
ELECTRICAL PROPERTY Dielectric Strength Dielectric Constant at 10 ³ Hz at 10 ⁶ Hz Dissipation Factor at 10 ³ Hz at 10 ⁶ Hz	V/mil	2,000 2.500 2.500 .003 .009	D149-64T D150-64T D150-64T		
UL INFORMATION Δ Min. Material Thickness Flammability Rating UL94 Hot Wire Ignition High Amp Arc Ignition High Volt Track Rate		.058 .120 V-0 V-0 20 20 39 39 8.2 8.2			

COST CODE (CC COLUMN)

CODE	A	B	C	D	E	F	G	H	I	J	K	L	M	N	O
≈ VALUE with +	.75¢	2¢	3.75¢	6¢	10¢	18¢	35¢	60¢	\$1	\$2	\$3.75	\$6	\$10	\$18	\$35+
≈ VALUE no suffix	.5¢	1.5¢	3¢	5¢	8¢	15¢	25¢	50¢	75¢	\$1.50	\$3	\$5	\$8	\$15	\$25
≈ VALUE with -	.2¢	1.25¢	2.5¢	4.25¢	7¢	13¢	22¢	40¢	65¢	\$1.25	\$2.50	\$4.25	\$7	\$13	\$22

NOTE: Costs may vary from order to order due to order quantities, vendor, etc.

Δ See Page 1-44 for definitions of UL terms used in Section 1.

PLASTIC MOLDING MATERIAL (CONT)

METHYLPENTENE POLYMER

DESCRIPTION		REMARKS	PART NUMBER	CC	
MATERIAL	COLOR			LB	CU IN
TPX-RT-18	Natural	Transparent	255-0466-00	J+	D
PROPERTIES	UNIT OF MEASURE	TPX-RT-18	ASTM TEST METHOD		
PHYSICAL PROPERTY Specific Gravity Mold Shrinkage Melting Point Water Absorption, 24 hrs.	in/in °F %	.835 .015-.030 455 .010	D1505 D955 D570		
MECHANICAL PROPERTY Tensile Strength, yield Elongation Flexural Modulus Impact Strength, Notched Izod Hardness, Rockwell	psi % psi ft·lb/in	35,600 40 160,000 R80 .950	D638 D638 D790 D256		
THERMAL PROPERTY Thermal Conductivity Specific Heat Linear Thermal Expansion Flammability	Btu in/hr ft ² Btu/lb °F in/in/°F in/min	11.600 .470 6.5 x 10 ⁻⁵ 1.	C177 C351 D696 D635		
ELECTRICAL PROPERTY Volume Resistivity Dielectric Strength Dielectric Constant 10 ² -10 ⁶ Hz	Ω/cm V/mil	>10 ¹⁶ 700 2.120	D257 D149 D150		
UL INFORMATION		NOT UL RECOGNIZED			

COST CODE

(CC COLUMN)

CODE	A	B	C	D	E	F	G	H	I	J	K	L	M	N	O
≈ VALUE with +	.75¢	2¢	3.75¢	6¢	10¢	18¢	35¢	60¢	\$1	\$2	\$3.75	\$6	\$10	\$18	\$35+
≈ VALUE no suffix	.5¢	1.5¢	3¢	5¢	8¢	15¢	25¢	50¢	75¢	\$1.50	\$3	\$5	\$8	\$15	\$25
≈ VALUE with -	.2¢	1.25¢	2.5¢	4.25¢	7¢	13¢	22¢	40¢	65¢	\$1.25	\$2.50	\$4.25	\$7	\$13	\$22

NOTE: Costs may vary from order to order due to order quantities, vendor, etc.

PLASTIC MOLDING MATERIAL (CONT)

PHENOLIC

DESCRIPTION		REMARKS	PART NUMBER	CC	
MATERIAL	COLOR			LB	CU IN
Fiberite FM-4004 Fiberite FM-4005 Rogers RX-640	Black Green Black	Glass Filled Glass Filled Glass Filled	255-0282-00 255-0148-00 255-0386-00	I+ J+ J+	D+ E+ E+
PROPERTIES	UNIT OF MEASURE	FIBERITE FM-4004	FIBERITE FM-4005	ROGERS RX-640	ASTM TEST METHOD
PHYSICAL PROPERTY Specific Gravity Mold Shrinkage Water Absorption, 24 hrs.	in/in %	1.920 .001-.003 .150	1.780 .001-.003 .100	1.750 .002 .200	D792 D955 D570
MECHANICAL PROPERTY Tensile Strength, break Flexural Strength Flexural Modulus Impact Strength, Notched Izod Hardness, Rockwell	psi psi psi ft-lb/in	8,000 12,000 2,300,000 M110 .450	10,000 15,000 M128 .600	9,000 14,000 18,000 M110	D638 D790 D790 D256 D785
THERMAL PROPERTY Linear Thermal Expansion Deflection Temperature at 66 psi at 264 psi	in/in/°F °F °F	1.4 x 10 ⁻⁵ 350	375	.83 x 10 ⁻⁵ 450	D696 D648
ELECTRICAL PROPERTY Dielectric Strength, Short Time Dielectric Constant at 10 ³ Hz at 10 ⁶ Hz Dissipation Factor at 10 ³ Hz at 10 ⁶ Hz	V/mil	320 4.500 .020	350 4.200-4.500 .012- .014	310 5.600 .029 .025	D149 D150 D150
UL INFORMATION Δ Min. Material Thickness Flammability Rating UL94 Hot Wire Ignition High Amp Arc Ignition High Volt Track Rate		.058 .120 .250 V-0 V-0 V-0 84 300+ 300+ 9 10 0 0 0 0	.120 .240 V-0 V-0 300+ 300+ 10 -- 0 0	NOT UL RECOGNIZED	

COST CODE

(CC COLUMN)

CODE	A	B	C	D	E	F	G	H	I	J	K	L	M	N	O
≈ VALUE with +	.75¢	2¢	3.75¢	6¢	10¢	18¢	35¢	60¢	\$1	\$2	\$3.75	\$6	\$10	\$18	\$35+
≈ VALUE no suffix	.5¢	1.5¢	3¢	5¢	8¢	15¢	25¢	50¢	75¢	\$1.50	\$3	\$5	\$8	\$15	\$25
≈ VALUE with -	.2¢	1.25¢	2.5¢	4.25¢	7¢	13¢	22¢	40¢	65¢	\$1.25	\$2.50	\$4.25	\$7	\$13	\$22

NOTE: Costs may vary from order to order due to order quantities, vendor, etc.

PLASTIC MOLDING MATERIAL (CONT)

POLYALLOMER

1

DESCRIPTION		REMARKS	PART NUMBER	CC	
MATERIAL	COLOR			LB	CU IN
Tenite M7853	Natural 146E	Extrusion Grade	255-0359-00	I+	C
PROPERTIES	UNIT OF MEASURE	TENITE M7853	ASTM TEST METHOD		
PHYSICAL PROPERTY Specific Gravity Melt Flow	g/10 min	.896 2.000	D1505 D1238L		
MECHANICAL PROPERTY Tensile Strength, yield Stiffness in Flexure Impact Strength, Izod Notched, at 23°C (73°F) Unnotched, at 23°C (73°F) Unnotched, at -18°C (0°F) Hardness, Rockwell	psi psi ft-lb/in ft-lb/in ft-lb/in	3,450 85,000 6.000 No Break 8.000 R56	D638 D747 D256 D785		
THERMAL PROPERTY Vicat Soft Point Deflection Temperature at 66 psi at 264 psi	°C °F	125 50 122	B1525 D648		
UL INFORMATION		NOT UL RECOGNIZED			

COST CODE (CC COLUMN)

CODE	A	B	C	D	E	F	G	H	I	J	K	L	M	N	O
≈ VALUE with +	.75¢	2¢	3.75¢	6¢	10¢	18¢	35¢	60¢	\$1	\$2	\$3.75	\$6	\$10	\$18	\$35+
≈ VALUE no suffix	.5¢	1.5¢	3¢	5¢	8¢	15¢	25¢	50¢	75¢	\$1.50	\$3	\$5	\$8	\$15	\$25
≈ VALUE with -	.2¢	1.25¢	2.5¢	4.25¢	7¢	13¢	22¢	40¢	65¢	\$1.25	\$2.50	\$4.25	\$7	\$13	\$22

NOTE: Costs may vary from order to order due to order quantities, vendor, etc.

PLASTIC MOLDING MATERIAL (CONT)

POLYAMIDE (NYLON) (PA)

1

DESCRIPTION		NYLON TYPE	REMARKS	PART NUMBER	CC	
MATERIAL	COLOR				LB	CU IN
Nylafil G-1/30/TF44 Nylafil J-1/30 Nylafil J-1/30 Nylafil J-1/30/FR Nylafil J-4/30/FR Nylafil J-4/30/FR	Natural Lt. to Med. Gray 1981 Black 223 Silver Gray Gy-4265 Black BK-2989 Natural	6/6 6/6 6/6 6/6 6/12 6/12	44% Teflon Filled, 30% Glass Filled 30% Glass Filled 30% Glass Filled 30% Glass Filled, Fire Retardant 30% Glass Filled, Fire Retardant 30% Glass Filled, Fire Retardant	255-0542-00 255-0026-00 255-0117-00 255-0548-00 255-0625-00 255-0634-00	K J J+ K- K K	G E- E E+ E+ E+
PROPERTIES	UNIT OF MEASURE	NYLAFIL G-1/30/TF44	NYLAFIL J-1/30	NYLAFIL J-1/30/FR	NYLAFIL J-4/30/FR	ASTM TEST METHOD
PHYSICAL PROPERTY						
Specific Gravity		1.560	1.420	1.500	1.500	D792-60T D955
Mold Shrinkage						
in .125 in average section	in/in	.006	.003		.003	
in .250 in average section	in/in	.007	.004		.006	
in .500 in average section	in/in	.008	.005	.005		
Melting Point	°F	495 - 505	495		405	D789-62T D570-63
Water Absorption, in 24 hrs.	%	.500	.900	.600	.130	
Water Absorption to Saturation	%	4.				
MECHANICAL PROPERTY						
Tensile Strength, break	psi	16,000	23,000	16,000	16,500	D638-61T D638-61T
Elongation	%	1.600	1.900	2.100	2.500	D638-61T
Tensile Modulus	psi		130,000		110,000	D790-63
Flexural Strength	psi	21,000	26,000	27,000	25,000	D790-63
Flexural Modulus	psi		950,000		130,000	D695-63T
Compressive Strength	psi	16,000	28,000		19,000	D732-78
Shear Strength	psi	9,000	11,000			D256-56
Impact Strength, Izod	ft.lb/in	3.000	1.500	1.600	1.500	
Hardness, Rockwell		E45-55	E60-70		M70-80	
THERMAL PROPERTY						
Linear Thermal Expansion	in/in/°F	2.1×10^{-5}	2.1×10^{-5}		1.0×10^{-5}	D696-44
Deformation under Load, at 4000 psi, 122°F	%	.700				
Deflection Temperature, at 264 psi	°F	494	485	320	375	D648-56
ELECTRICAL PROPERTY						
Volume Resistivity	Ω -cm		1.0×10^{16}			D257
Dialectric Strength	V/10 ⁻³ in		500			D149
Dialectric Constant at 100 Hz			4.100			D150
at 10 ³ Hz			4.000			
UL INFORMATION Δ						
Min. Material Thickness		.028 .062 .125 .250	.028	.028	.062	
Flammability Rating UL94		HB HB HB HB	HB	V-0	V-0	
Hot Wire Ignition		8 13 84 300+	8	300+	200+	
High Amp Arc Ignition		200+ 200+ 200+ 200+	200+	200+	200+	
High Volt Track Rate		1.1 0 0 0	3	14	6.7	

Δ See Page 1-44 for definitions of UL terms used in Section 1.

PLASTIC MOLDING MATERIAL (CONT)

POLYAMIDE (NYLON) (PA)

DESCRIPTION		NYLON TYPE	REMARKS	PART NUMBER	CC	
MATERIAL	COLOR				LB	CU IN
Capron 8202	Black 102	6		254-0987-00	I+	C
Capron 8202	Lt. to Med. Gray 151	6		255-0007-00	K	E+
Nylafil J-4/40	Black 223	6/12	40% Glass Filled	255-0172-00	K-	F-
Nylafil J-4/40	Silver Gray 4510	6/12	40% Glass Filled	255-0387-00	K-	F-
Nylafil J-4/40	Smoke Tan	6/10	40% Glass Filled	255-0387-01	K+	F+
Nylafil J-4/40	Earth Brown	6/10	40% Glass Filled	255-0387-02	K	F
Nylafil J-4/40	Tek Blue 4758	6/12	40% Glass Filled	255-0471-00	K-	F-
Nylafil J-4/40	Gray 4801	6/12	40% Glass Filled	255-0766-00	K-	F-
Zytel 31	Natural 10	6/10		255-0365-00	J-	D-
Zytel 101	White 11	6/6		254-0940-00	J+	D+
Zytel 101	Red 601	6/6		255-0033-00	J	D+
Zytel 101	Medium Gray 07	6/6		254-0995-00	K-	E+
Zytel 101	Dark Gray 48	6/6		255-0050-00	K-	E+
Zytel 105	Black 10	6/6	Weather Stabilized	254-0925-00	J+	D+

PROPERTIES	UNIT OF MEASURE	CAPRON 8202	NYLAFIL J-4/40	ZYTEL 31	ZYTEL 101	ZYTEL 105	ASTM TEST METHOD
PHYSICAL PROPERTY							
Specific Gravity		1.130	1.430	1.070-1.090	1.140	1.140	D792
Mold Shrinkage	in/in	.013	.004	.015	.015	.015	D955
Melting Point	°F	410 - 435			520		D789
Water Absorption, 24 hrs.	%	1.600	.170	.400	1.200	1.500	D570
MECHANICAL PROPERTY							
Tensile Strength, yield	psi	11,800	28,000	8,500	8,500	13,100	D638
Elongation	%	25	2.200	85	25	35	D638
Tensile Modulus	psi	340,000			200,000	400,000	D638
Flexural Strength	psi	15,500	34,000	280,000			D638
Flexural Modulus	psi	395,000	1,500,000			191,000	D790
Impact Strength, Notched Izod	ft-lb/in	1.200	4.500	.600	1.000	.950	D790
Hardness, Rockwell		R119	E55-65	R111	R121	R120	D256
THERMAL PROPERTY							
Linear Thermal Expansion	in/in/°F	4.6×10^{-5}	1.4×10^{-5}	5.0×10^{-5}	4.5×10^{-5}	5.0×10^{-5}	D696
Deflection Temperature at 66 psi	°F	340	440	300	455	392	D648
Deflection Temperature at 264 psi		152	426	135	194	167	
ELECTRICAL PROPERTY							
Dielectric Strength, Short Time	V/mil	420	500		385	385	D149
Dielectric Constant at 10 ³ Hz		3.700	4.200	3.600	3.900	4.000	D150
Dielectric Constant at 10 ⁶ Hz		3.400	4.000	3.500	3.600	3.400	
Dissipation Factor at 10 ³ Hz		.016	.014	.040	.020	.020	D150
Dissipation Factor at 10 ⁶ Hz		.025	.016	.030	.040	.040	
UL INFORMATION Δ							
Min. Material Thickness		.028 .058 .12 .24	NOT UL RECOGNIZED	NOT UL RECOGNIZED	.028 .058 .12 .24	.028 .058 .12 .24	
Flammability Rating UL94		V-2 V-2 V-2 V-2			V-2 V-2 V-2 V-2	V-2 V-2 V-2 V-2	
Hot Wire Ignition		-- 8 18 33			-- 15 35 35	-- 15 35 35	
High Amp Arc Ignition		-- 200+ 200+200+			-- 186 182 200+	-- 186 182 200+	
High Volt Track Rate		-- .3 .2 .2			-- .2 .4 .4	-- .2 .4 .4	

Solvent Resistance: Resistant to common organic solvents, oils, greases, etc.; slowly attacked by strong acids and oxidizing agents.

PLASTIC MOLDING MATERIAL (CONT)

POLYAMIDE (NYLON) (PA)

1

DESCRIPTION		NYLON TYPE	REMARKS	PART NUMBER	CC		
MATERIAL	COLOR				LB	CU IN	
Thermocomp IF1004 Thermocomp IFL4536	White WT-9-033 Black 8-115	6/10 6/12	20% Glass Filled 30% Glass Fiber Filled, 13% Teflon, 2% Silicone, Flame Retardant 20% Glass Filled	255-0303-00 255-0745-00	L+ L	G G-	
Thermocomp QF1004	Tek Blue 5-808	6/10		255-0368-00	K-	E+	
Thermocomp QF1004 Thermocomp RF-1006 Zytel 70G33L	Black 8-085 Slate Gray Black 31	6/10 6/6 6/6		255-0294-00 255-0822-00 255-0332-00	K- L- J	E+ F+ E-	
PROPERTIES	UNIT OF MEASURE	THERMOCOMP IF1004		THERMOCOMP IFL4536	THERMOCOMP QF1004	THERMOCOMP RF-1006	ZYTEL 70G33L
PHYSICAL PROPERTY Specific Gravity Mold Shrinkage Water Absorption, 24 hrs.	in/in %	1.210 .004 .220	1.640 .003 .080	1.220 .004 .220	1.370 .004 -.005 .900	1.380 .001 -.004 1.000	D792 D955 D750
MECHANICAL PROPERTY Tensile Strength, yield Tensile Strength, break Elongation Flexural Strength Flexural Modulus Impact Strength, Izod (.125) Hardness, Rockwell	psi psi % psi psi psi	18,000 5-6 28,000 900,000 1.100 M89, R119	20,000 25,000 3-4 950,000 1.600 R100	18,000 3-4 26,000 900,000 1.100 M89, R119	26,000 3-4 38,000 1,300,000 1.200 M96	27,000 27,000 3 38,500 1,300,000 2.100 M101	D638 D638 D638 D790 D790 D256 D785
THERMAL PROPERTY Linear Thermal Expansion Deflection Temperature at 264 psi	in/in/°F °F	2.2 x 10 ⁻⁵ 410	2.7 x 10 ⁻⁵ 400	2.2 x 10 ⁻⁵ 410	490	1.3 x 10 ⁻⁵ 480	D696 D648
UL INFORMATION Δ Min. Material Thickness Flammability Rating UL94 Hot Wire Ignition High Amp Arc Ignition High Volt Track Rate		NOT UL RECOGNIZED	NOT UL RECOGNIZED	NOT UL RECOGNIZED	.120 HB 11 180 .8	.028 .058 .120 -- HB HB -- 7 9 -- 200+ -- -- .6 .5	

DESCRIPTION		NYLON TYPE	REMARKS	PART NUMBER	CC	
MATERIAL	COLOR				LB	CU IN
Nylatron GS Nylatron GS-51	Natural (Charcoal Gray) Natural (Charcoal Gray)	6/6 6/6	Molydisulphide Filled Molydisulphide Filled (30% Glass)	255-0378-00 255-0539-00	J+ J+	D+ E
PROPERTIES	UNIT OF MEASURE	NYLATRON GS	NYLATRON GS-51	ASTM TEST METHOD		
PHYSICAL PROPERTY Specific Gravity Melting Point Water Absorption, at 24 hrs.	°F %	1.140-1.180 496 ±9 .500-1.400	1.390-1.410 489 ±9 .550-.650	D792 D789 D570		
MECHANICAL PROPERTY Tensile Strength, break Elongation Flexural Strength Hardness, Rockwell	psi psi	10,000-14,000 5-150 16,000-19,000 R110-125	20,000-22,000 5-10 28,000-30,000 R119-120	D638 D638 D790 D785		
THERMAL PROPERTY Linear Thermal Expansion Deflection Temperature at 66 psi at 264 psi	in/in/°F °F	3.5 x 10 ⁻⁵ 400-490 200-470	1.1-1.8 x 10 ⁻⁵ 480-490	D696 D648		
ELECTRICAL PROPERTY Dielectric Strength, Short Time	V/mil	300-400		D149		
UL INFORMATION Δ Min. Material Thickness Flammability Rating UL94 Hot Wire Ignition High Amp Arc Ignition High Volt Track Rate		.058 .124 .240 V-2 V-2 V-2 19 42 63 200+ 200+ 200+ .5 .5 .4	NOT UL RECOGNIZED			

Δ See Page 1-44 for definitions of UL terms used in Section 1.

PLASTIC MOLDING MATERIAL (CONT)

POLYCARBONATE (PC)

DESCRIPTION							CC		
MATERIAL	COLOR	REMARKS					PART NUMBER	LB	CU IN
Thermocomp DF-1003	Black	15% Carbon Fiber Filled					255-0696-00	M-	G+
Thermocomp DF-1003	Light to Medium Gray 0-652	15% Glass Filled					255-0308-00	K-	E+
Thermocomp DF-1004	Medium Gray 0-015	20% Glass Filled, Milled Fiber					255-0235-00	K-	E+
Thermocomp DF-1004	Tek Blue 5-565	20% Glass Filled					255-0423-00	J+	E
Thermocomp DF-1004	Medium Gray GY0-897	20% Glass Filled					255-0804-00	K+	F
Thermocomp DF-1004	Gray 0-312	20% Glass Filled					255-0532-00	K-	E+
Thermocomp DF-1004	Gray GY0-378	20% Glass Filled					255-0654-00	M-	G+
Thermocomp DF-1004	Smoke Tan BN7-325	20% Glass Filled					255-0824-00	K-	E+
Thermocomp DF-1004	Dove Gray 640-885	20% Glass Filled					255-0825-00	K-	E+
Thermocomp DFA-113-V1	Tek Tan GY0-190	10% Glass Filled, Fire Retardant					255-0710-00	K	F-
Thermocomp DFA-113	Tek Blue 5-548	10% Glass Filled, Fire Retardant					255-0617-00	J+	E-
Thermocomp DFA-113	TV Gray GY0-971	10% Glass Filled, Fire Retardant					255-0773-00	L-	F+
Thermocomp DFA-113	Smoke Tan	10% Glass Filled, Fire Retardant					255-0617-01	L	G-
Thermocomp DFA-113	Earth Brown	10% Glass Filled, Fire Retardant					255-0617-02	K	F-
Thermocomp DFA-113	Ivory Gray	10% Glass Filled, Fire Retardant					255-0617-04	K	F-
Thermocomp DFA-113	Slate Gray	10% Glass Filled, Fire Retardant					255-0617-03	L	G-
Thermocomp DFL-4034	Natural	15% Teflon Filled, 20% Glass Filled					255-0470-00	K	F
Thermocomp DFL-4034	Black 8114	15% Teflon Filled, 20% Glass Filled					255-0470-01	K	F
Thermocomp DFL-4034	TV Gray GY0-966	15% Teflon Filled, 20% Glass Filled					255-0470-02	K+	F+
Thermocomp DFL-4034	New Generation Gray 0-312	15% Teflon Filled, 20% Glass Filled					255-0700-00	K	F
Thermocomp DFL-4536	Black 8115	30% Glass Filled, 13% Teflon Filled, 2% Silicone Filled					255-0744-00	K+	F+
Thermocomp DL-4020	Natural	10% Teflon Filled					255-0504-00	K	F-
Thermocomp DL-4020	Blue 5-477	10% Teflon Filled					255-0612-00	K+	F
Thermocomp DL-4020	Smoke Tan						255-0612-01		
Thermocomp DL-4020	Earth Brown						255-0612-02	L+	G
Thermocomp DL-4020	Slate Gray						255-0612-03	L+	G
Thermocomp DL-4020	Flint Gray						255-0612-04	L+	G
PROPERTIES	UNIT OF MEASURE	THERMOCOMP DF-1003	THERMOCOMP DF-1004	THERMOCOMP DFA-113	THERMOCOMP DFL-4034	THERMOCOMP DFL-4536	THERMOCOMP DL-4020	ASTM TEST METHOD	
PHYSICAL PROPERTY									
Specific Gravity		1.310	1.350	1.250	1.450	1.640	1.260	D792	
Mold Shrinkage	in/in	.001-.002	.0005	.003	.001-.002		.005-.007	D955	
Melting Point	°F			600				D789	
Water Absorption, 24 hrs.	%	.110	.090	.110	.080	.060	.130	D570	
MECHANICAL PROPERTY									
Tensile Strength, break	psi	14,000	16,000	9,500	14,500	17,500	7,500	D638	
Elongation	%	4-6	4-6	5	4-6	4-5	30	D638	
Tensile Modulus	psi		1,000,000					D638	
Flexural Strength	psi	22,000	25,000	16,000	21,000	25,000	10,000	D790	
Flexural Modulus	psi	700,000	850,000	500,000	800,000	1,200,000	300,000	D790	
Impact Strength, Notched .250 inch	ft·lb/in	2.800	3.400	2.300	1.900	2.200	2.500	D256	
Unnotched, .250 inch	ft·lb/in	12-14		30-40	8-10	12-14	35		
Hardness, Rockwell			M92,R118	R115					
THERMAL PROPERTY									
Linear Thermal Expansion	°F	1.7×10^{-5}	1.5×10^{-5}	1.8×10^{-5}	1.8×10^{-5}	1.5×10^{-5}	3.9×10^{-5}	D696	
Thermal Conductivity	Btu in/hr ft ² /°F	2.000	2.300	1.700	2.000		1.300	C177	
Deflection Temperature, at 264 psi	°F	295	300	290	290	143	265	D648	
UL INFORMATION Δ									
Min. Material Thickness		.061 .120	.062 .120	.062	.062 .250	NOT UL RECOGNIZED	.071 .260		
Flammability Rating UL94		V-1 V-1	V-1 V-1	V-0	V-1 V-0		V-2 V-0		
Hot Wire Ignition		300+ 300+	300+ 300+	--	-- --		-- --		
High Amp Arc Ignition		6 31	6 31	--	-- --		-- --		
High Volt Track Rate		6.3 7.7	6.3 7.7	--	-- --		-- --		

PLASTIC MOLDING MATERIAL (CONT)

POLYCARBONATE (PC)

1

DESCRIPTION		REMARKS	PART NUMBER	CC	
MATERIAL	COLOR			LB	CU IN
Merlon M39U Merlon M39U Merlon M39U Merlon M39U Merlon M39U	Blue Transparent SM2392A Clear 1040 Green SM955A Amber 6801 Smoke Gray 2833	Opt Grade-UV Stable Opt Grade-UV Stable Opt Grade-UV Stable Opt Grade-UV Stable Opt Grade-UV Stable	255-0688-00 255-0339-00 255-0438-00 255-0443-00 255-0445-00	K- J+ K+ K+ K+	E+ E- F F F
Merlon M39U Merlon M40U Merlon M40U Merlon M40U Merlon M40U	Blue 8819 Blue 2 8042 Smoke Tan Earth Brown Slate Gray	Opt Grade-UV Stable Opaque; UV Stable Opaque; UV Stable Opaque; UV Stable Opaque; UV Stable	255-0444-00 255-0488-00 255-0488-01 255-0488-02 255-0488-03	K- K K- K+ K+	E+ F- E+ F F
Merlon M40U Merlon M40U Merlon M40U Merlon M40U Merlon M50U	Ivory Gray Dove Gray Black 701 Dark Green 9866 Green 9007	Opaque; UV Stable Opaque; UV Stable Opt Grade; UV Stable Opaque; UV Stable, Flame Retardant	255-0488-04 255-0488-05 254-0979-00 255-0826-00 255-0779-00	K+ K+ J L- K	F F D+ F+ F-
PROPERTIES	UNIT OF MEASURE	MERLON M39U, M40U, M50U	ASTM TEST METHOD		
PHYSICAL PROPERTY Specific Gravity Mold Shrinkage Water Absorption, 24 hrs.	in/in %	1.200 .005-.007 .180	D792 D955 D570		
MECHANICAL PROPERTY Tensile Strength, yield Elongation Flexural Strength Flexural Modulus Impact Strength, Notched Izod Hardness, Rockwell	psi % psi psi ft/lb	8,000-9,500 100-130 10,300-12,700 320,000-350,000 12-18 (.125) R115-125	D638 D638 D790 D790 D256 D785		
THERMAL PROPERTY Linear Thermal Expansion Deflection Temperature at 264 psi	in/in/°F °F	390,000-700,000 265-290	D696 D648		
ELECTRICAL PROPERTY Dielectric Strength, Short Time Dielectric Constant at 10 ² Hz at 10 ⁶ Hz Dissipation Factor at 10 ² Hz at 10 ⁶ Hz	V/mil	400 @ .125 mil 2.970 2.950 .0006 .009	D149 D150 D150		
UL INFORMATION Δ Min. Material Thickness Flammability Rating UL94 Hot Wire Ignition High Amp Arc Ignition High Volt Track Rate	MERLON M39U .062 .250 HB HB -- -- -- -- -- --	MERLON M40U .058 .120 .240 V-0 V-0 V-0 24 50 139 200+ 200+ 200+ 1.08 -- --	MERLON M50U .058 .120 .240 HB HB V-0 29 89 127 200+ 200+ 200+ .83 -- --		

Δ See Page 1-44 for definitions of UL terms used in Section 1.

PLASTIC MOLDING MATERIAL (CONT)

POLYCARBONATE (PC)

DESCRIPTION		REMARKS	PART NUMBER	CC	
MATERIAL	COLOR			LB	CU IN
Lexan 101	Medium Gray 7002		255-0082-00	J+	E-
Lexan 141R	Light to Medium Gray 70044		255-0264-00	L-	F+
Lexan 141R	Tek Blue 2095		255-0267-00	J+	E-
Lexan 141R	Natural 112		255-0270-00	J+	E-
Lexan 141R	New Generation Gray 70075		255-0286-00	K	F-
Lexan 141R	Charcoal Gray 70078		255-0292-00	K	F-
Lexan 141R	Silver Gray 70092		255-0298-00	J+	E-
Lexan 141R	Yellow 401		255-0364-00	K	F-
Lexan 141R	Gray 70363	Color matched to 255-0302-00	255-0652-00	K+	F
Lexan 143R	White 803		255-0156-00	K	F-
Lexan 143R	Red TP 612	Optical grade; UV Stable	255-0651-00	K	F-
Lexan 143R	White 8244		255-0327-00	K	F-
Lexan 900/Merlon SF600 *	Tan	Struct Foam Grd, 5% Glass Filled, Fire Retardant	255-0757-00	K-	
Lexan 900/Merlon SF600 *	Smoke Tan	Struct Foam Grd, 5% Glass Filled	255-0757-01	K+	
Lexan 900/Merlon SF600 *	Earth Brown	Struct Foam Grd, 5% Glass Filled	255-0757-02		
Lexan 900/Merlon SF600 *	Slate Gray	Struct Foam Grd, 5% Glass Filled	255-0757-03		
Lexan 910	Natural	Struct Foam Grd, 10% Glass Filled, Fire Retardant	255-0783-00	J-	
Lexan 940	New Generation Gray 70075	Fire Retardant	255-0317-01	K+	F
Lexan 940	Silver Gray 7227	Fire Retardant	255-0540-01	K-	E+
Lexan 940	Tek Blue 2095	Fire Retardant	255-0527-01	J+	E-
Lexan 940	TV Gray 70387	Fire Retardant	255-0565-01	K-	E+
Lexan 940	Smoke Tan	Fire Retardant	255-0565-02	K+	F
Lexan 940	Earth Brown	Fire Retardant	255-0565-03	K-	E+
Lexan 940	Slate Gray	Fire Retardant	255-0565-04	K-	E+
Lexan 940	Ivory Gray	Fire Retardant	255-0565-05	K-	E+
Lexan 940	Dove Gray	Fire Retardant	255-0565-06	K-	E+
Lexan 940	Black 701	Fire Retardant	255-0574-01	J+	E-
Lexan 940	Brown 50639	Fire Retardant	255-0735-00	K	F-
Lexan 940	Red 6214	Fire Retardant	255-0736-00	K+	F
Lexan 940	Orange 62039	Fire Retardant	255-0737-00	K+	F
Lexan 940	Yellow 4217	Fire Retardant	255-0738-00	K+	F
Lexan 940	Green 30146	Fire Retardant	255-0739-00	K	F-
Lexan 940	Blue 20142	Fire Retardant	255-0740-00	K	F-
Lexan 940	Purple 20127	Fire Retardant	255-0741-00	K	F-
Lexan 940	Gray 7058	Fire Retardant	255-0742-00	K	F-
Lexan 940	White 82355		255-0743-00	K	F-
Lexan ML4024R	Tek Blue 2095	Fire Retardant	255-0814-00	J+	E

PROPERTIES	UNIT OF MEASURE	LEXAN 101, 141R, 143R	LEXAN 910	LEXAN 940	LEXAN ML4024R	ASTM TEST METHOD
PHYSICAL PROPERTY Specific Gravity		1.200		1.210	1.210	D792
Mold Shrinkage	in/in			.005-.007		D955
Water Absorption, 24 hrs.	%	.150	.120	.150	.150	D570
MECHANICAL PROPERTY Tensile Strength, yield	psi	9,000	6,300	9,000	9,000	D638
Elongation	%	110	3	90	6-8	D638
Flexural Strength	psi	13,500	12,540	13,200	13,200	D790
Flexural Modulus	psi	340,000		325,000	325,000	D695, D790
Impact Strength, Notched Izod	ft/lb	16 (.125)		12 (.125)	10 (.125)	D785
Hardness, Rockwell		M70		M70	M70	
THERMAL PROPERTY Linear Thermal Expansion	in/in/°F	3.75×10^{-5}	1.8×10^{-5}	3.75×10^{-5}	3.75×10^{-5}	D696
Deflection Temperature at 66 psi	°F	280		280	280	D648
at 264 psi		270		270	270	
ELECTRICAL PROPERTY Dielectric Strength, Short Time	V/mil	380 (.125)	245	380 (.125)	380	D149
Dielectric Constant						D150
at 10 ² Hz		3.170	2.410	3.010	3.010	
at 10 ⁶ Hz		2.960	2.330	2.960	2.960	
Dissipation Factor						D150
at 10 ² Hz		.0009	.0029	.0009	.0009	
at 10 ⁶ Hz		.010	.0081	.010	.010	
UL INFORMATION Δ						
Min. Material Thickness		.058 .124 .240		.058 .120	.093	
Flammability Rating UL94		V-2 V-2 V-0	V-0	V-0 V-0	V-0	
Hot Wire Ignition		37 40 40	46	23 37		
High Amp Arc Ignition		200+ 81 81		17 20	10	
High Volt Track Rate		2.6 2.6 2.2	7.4	5.8 6.2		

PLASTIC MOLDING MATERIAL (CONT)

POLYETHYLENE (PE)

1

DESCRIPTION		REMARKS	PART NUMBER	CC			
MATERIAL	COLOR			LB	CU IN		
Marlex 4903 Marlex 6050	Natural Natural	Extrusion Grade, High Density Injection Molding/Extrusion Grade, High Density	255-0215-00 255-0110-00	H+ H+	B+ B+		
PROPERTIES	UNIT OF MEASURE	MARLEX 4903	MARLEX 6050	ASTM TEST METHOD			
PHYSICAL PROPERTY							
Density	in/in	.950	.960	D792 D955-51 D1238-57T			
Mold Shrinkage		.020-.050	.020-.050				
Melt Index		.300-6.500	.200-5.000				
MECHANICAL PROPERTY							
Tensile Strength, yield	psi	3,800	4,400	D412-51T D695-54 D638-56T D412-51T D412-51T D412-51T D412-51T D412-51T D695-54 D790-49T D747-50 D790-49T D256-56			
Elongation	psi	80,000	100,000				
Tensile Modulus	psi	110,000	150,000				
Stress at 1% offset	psi	3,600	4,300				
Stress at Rupture	psi	2,100	2,400-4,400				
Strain at Yield	%	10	10				
Strain at Rupture	%	20-70	12-30				
Compressive Stress at 1% offset	psi	3,200	3,600				
Flexural Stress at 1% offset	psi	800	1,000				
Stiffness in Flexure	psi	115,000	160,000				
Flexural Modulus	psi	165,000	165,000				
Impact Strength, Notched Izod	ft·lb/in	.700-4.000	1-14				
Hardness, Rockwell		D67	D68				
THERMAL PROPERTY							
Thermal Conductivity	°F		3.700			C177-45 C351 D696-44	
Specific Heat	Cal/gm/°C		.458				
Linear Thermal Expansion	in/in/°C	1.3×10^{-4}	1.3×10^{-4}				
Deflection Temperature at 264 psi	°F	160	170	D648 D1525-58T			
Vicat Soft Temperature	°F	255	260				
Deformation Under Load	%	8.100	8.100	D621-51 D756-55T D635-56T			
Brittle Temperature	°F	-140 to <-180	-100 to <-180				
Flammability	in/min	1.040	1.040				
ELECTRICAL PROPERTY							
Dielectric Strength	V/mil	510	510	D149-55T D150-54T			
Dielectric Constant at 1 kHz		2.350	2.350				
Dielectric Constant at 1 MHz		2.350	2.350	D150-54T			
Dissipation Factor at 1 kHz		.0002	.0002				
Dissipation Factor at 1 MHz		.0003	.0003				
UL INFORMATION		NOT UL RECOGNIZED	NOT UL RECOGNIZED				

DESCRIPTION		REMARKS	PART NUMBER	CC	
MATERIAL	COLOR			LB	CU IN
Ethylene-Hexene-1 Copolymer*	Natural	High Density	255-0646-00	H	

* Properties information not available.

Δ See Page 1-44 for definitions of UL terms used in Section 1.

PLASTIC MOLDING MATERIAL (CONT)

POLYETHYLENE (PE)

DESCRIPTION		REMARKS	PART NUMBER	CC	
MATERIAL	COLOR			LB	CU IN
Tenite 808E Tenite 808E Tenite 811A Tenite 811A	Natural Black 60457 Natural Medium to Dark Gray 62843	Low Density, Extrusion Grade Injection Molding, Extrusion Grade Injection Molding, Low Density Injection Molding, Extrusion Grade	255-0508-00 254-0966-00 254-0939-00 255-0112-00	G+ I+ H H+	A+ C B B+
PROPERTIES	UNIT OF MEASURE	TENITE 808E	TENITE 811A	ASTM TEST METHOD	
PHYSICAL PROPERTY Specific Gravity Water Absorption, 24 hrs.	%	.919 .010	.917 .010	D792 D570	
MECHANICAL PROPERTY Tensile Strength Elongation Impact Strength, Notched Izod Hardness, Rockwell	psi % ft·lb	1,550 500 No Break J73	1,400 450 No Break J71	D638 D638 D256	
THERMAL PROPERTY Linear Thermal Expansion Deflection Temperature at 66 psi Vicat Soft Point	in/in/°F °F	11. x 10 ⁻⁵ 110 189	11. x 10 ⁻⁵ 100 183	D696 D648 D1525	
ELECTRICAL PROPERTY Dielectric Strength, Short Time Dielectric Constant at 10 ³ Hz at 10 ⁶ Hz Dissipation Factor at 10 ³ Hz at 10 ⁶ Hz	V/mil	1,000 2.300 2.300 .0005 .0005	1,000 2.300 2.300 .0005 .0005	D149 D150 D150	
UL INFORMATION Δ		NOT UL RECOGNIZED	NOT UL RECOGNIZED		
Solvent Resistance: Not affected by concentrated hydrochloric, sulphuric, or hydrofluoric acids or sodium hydroxide. No known organic solvents will dissolve polyethylene; however, some softening or embrittlement may occur. It is advised to test polyethylene carefully before use.					

DESCRIPTION		REMARKS	PART NUMBER	CC	
MATERIAL	COLOR			LB	CU IN
Avecor X-13330	Red, PE BMN 5565	Injection Molding, Extrusion Grade, Low Density, Color Concentrate, 25:1 letdown	255-0188-00	H+	B+
PROPERTIES	UNIT OF MEASURE	AVECOR X-13330	ASTM TEST METHOD		
PHYSICAL PROPERTY Specific Gravity Melt Index	g/10 Min	.923 30	D1505 D1238		
MECHANICAL PROPERTY Tensile Strength, yield Tensile Strength, break Elongation Stiffness in Flexure	psi psi % psi	1,800 1,500 100 24,000	D638 D638 D747		
THERMAL PROPERTY Vicat Soft Point Brittle Temperature	°C °F	90 -4	D1525 D746		
UL INFORMATION		NOT UL RECOGNIZED			

PLASTIC MOLDING MATERIAL (CONT)

POLYETHYLENE (PE)

1

DESCRIPTION		REMARKS			PART NUMBER	CC	
MATERIAL	COLOR					LB	CU IN
Bakelite DFD-4960 Bakelite DFD-6005 Bakelite DGDA-3363 Bakelite DHDA-7702	Natural Natural Natural Black	Foam, Extrusion Grade Injection Molding, Extrusion Grade Extrusion Grade Semiconducting (20Ω/cm) Extrusion Grade			255-0018-00 255-0071-00 255-0505-00 255-0374-00	H+ H H I-	A+ B B B+
PROPERTIES	UNIT OF MEASURE	BAKELITE DFD-4960	BAKELITE DFD-6005	BAKELITE DGDA-3363	BAKELITE DHDA-7702	ASTM TEST METHOD	
PHYSICAL PROPERTY Specific Gravity Melt Flow	g/10 Min	.440	.920 .300	.950 .250	.932	D1505 D1238	
MECHANICAL PROPERTY Tensile Strength, break Elongation Stiffness in Flexure 25°C 0°C -25°C -50°C Shear Strength Environmental Stress Cracking, F ₅₀ , hrs. Hardness, Shore	psi % psi psi	600 300	2,200 600 23,000 43,000 120,000 245,000 2,500 >300	3,000 600 100,000 200,000 300,000 400,000 3,000 >500	1,140 230	D638 D638 WC-72-B-1/1 D732-78 D732 D1693	
THERMAL PROPERTY Extrusion Compound Temperature at Die Brittle Temperature, 50% non-failure Deformation at 100°C	°F °C	300	400 -90 20	500 -95 0	350 -49	D746 D1706	
ELECTRICAL PROPERTY Dielectric Strength, Short Time Dielectric Constant, 1 MHz Dissipation Factor, 1 MHz	V/mil @.125	220 1.500 .0002	550 2.280 .0002	550 2.340 .0002		D149 D150 D150	
UL INFORMATION		NOT UL RECOGNIZED	NOT UL RECOGNIZED	NOT UL RECOGNIZED	NOT UL RECOGNIZED		

DESCRIPTION		REMARKS			PART NUMBER	CC	
MATERIAL	COLOR					LB	CU IN
Ultrathene UE630	Silver Gray YR21505	Vinyl Acetate 18%			255-0304-00	I+	C-
PROPERTIES	UNIT OF MEASURE	URETHANE UE630	ASTM TEST METHOD				
PHYSICAL PROPERTY Specific Gravity Melt Flow	g/10 Min	.940 1.300	D1238				
MECHANICAL PROPERTY Tensile Strength, break Elongation Torsional Stiffness Environmental Stress Crack Resistance Modulus of Elasticity 2% Secant 1% Secant (calculated from the 2% values) Hardness, Shore	psi % psi hr/°F psi	2,720 700 7,000 >3,000 7,200 8,300 D36, A92	D638 D638				
THERMAL PROPERTY Vicat Soft Point Brittle Temperature	°C °F	69 -105	D1525 D746				
UL INFORMATION		NOT UL RECOGNIZED					

PLASTIC MOLDING MATERIAL (CONT)

POLYPHENYLENE OXIDE (PPO)

DESCRIPTION						CC	
MATERIAL	COLOR					REMARKS	PART NUMBER
GE 534-801 Noryl FN-215 Noryl FN-215 Noryl FN-215 Noryl FN-215 Noryl N-190 Noryl N-190 Noryl SE-100	Natural 801 Tan 50017 Smoke Tan Earth Brown Slate Gray Black 701 Slate Gray 7887 Silver Gray 7042	Modified, Structural Foam Grade Structural Foam Grade Structural Foam Grade Structural Foam Grade Modified, Fire Retardant Structural Foam Grade Modified, Fire Retardant	255-0203-00 255-0756-00 255-0756-01 255-0756-02 255-0756-03 255-0615-00 255-0823-00 255-0328-00	L- J- J+	F C D D E D+		
PROPERTIES	UNIT OF MEASURE	GE 534-801	NORYL FN-215	NORYL N-190	NORYL SE-100	ASTM TEST METHOD	
PHYSICAL PROPERTY Specific Gravity Mold Shrinkage Water Absorption, 24 hrs.	in/in %	1.060 .007-.009 .030	.850 .006-.008 .060	1.080 .006 .070	1.100 .006 .070	D792 D955 D570	
MECHANICAL PROPERTY Tensile Strength, break Elongation Tensile Modulus Flexural Strength Flexural Modulus Impact Strength, Notched Izod Hardness, Rockwell	ksi % ksi ksi ksi ft-lb	11.600 20-40 390 16 375 1.200 M78,R119	3.400 16 235 12.540 260 18	7.000 360 11.500 325 7 R115	7.800 25 380 12.800 400 1.700 R115	D638 D638 D638 D790 D790 D256 D785	
THERMAL PROPERTY Linear Thermal Expansion Deflection Temperature at 66 psi at 264 psi	in/in/°F °F	29 x 10 ⁻⁶ 355 345	3.8 x 10 ⁻⁵ 205 180	210 190	3.7 x 10 ⁻⁵ 230 212	D696 D648	
ELECTRICAL PROPERTY Dielectric Strength, Short Time Dielectric Constant at 100 Hz at 10 ⁶ Hz Dissipation Factor at 100 Hz at 10 ⁶ Hz	V/mil	500 (.125 sample) 2.580 2.580 .00035 .0009	192 2.270 2.180 .0047 .0039	400 2.780 2.730 .0046 .0068	2.650 2.640 .0007 .0008	D149 D150 D150	
UL INFORMATION Δ Min. Material Thickness Flammability Rating UL94 Hot Wire Ignition High Amp Arc Ignition High Volt Track Rate		NOT UL RECOGNIZED	V-0 111 -- 8.6	.058 .240 V-0 V-0 41 61 58 200+ 14 11.7	.060 .090 .240 V-1 V-1 V-0 58 58 95 200+ 200+ 200+ 9 9 11		
Solvent Resistance: Resistant to detergents and acids. Softens or dissolves in halogenated and aromatic hydrocarbons. Subject to stress failure induces by petroleum derivatives and FREON _R TF when applied under load.							

⊕ = Not recommended for new design.

PLASTIC MOLDING MATERIAL (CONT)

POLYPHENYLENE SULFIDE

1

DESCRIPTION		REMARKS		PART NUMBER	CC	
MATERIAL	COLOR				LB	CU IN
Ryton R-4 Thermocomp OF-1008 Thermocomp OFL-4042	Natural (Dark Brown) Natural Dark Blue 5490	40% Glass Reinforced 10% Glass, 20% Teflon Reinforced 40% Glass Reinforced	255-0538-00 255-0624-00 255-0695-00	M- M- L	H- H- G	
PROPERTIES	UNIT OF MEASURE	RYTON R-4	THERMOCOMP OF-1008	THERMOCOMP OFL-4042	ASTM TEST METHOD	
PHYSICAL PROPERTY Specific Gravity Water Absorption, 24 hrs.	%	1.640 <.050	1.650 .020	1.540	D1505-68 D570-63	
MECHANICAL PROPERTY Tensile Strength Elongation Flexural Strength Flexural Modulus Compressive Strength Impact Strength, Izod Notched, .125 in specimen Unnotched, .125 in specimen Hardness, Rockwell	psi % psi psi psi ft/lb/in	19,500 (Break) 1.300 29,000 1,700,000 21,000 1.500 8 R123	23,000 (Yield) 3-4 32,000 1,800,000 1.500	12,500 3-4 17,000 800,000 .600 5-6	D638-72 D638-72 D790-71 D790-71 D695-69 D256	
THERMAL PROPERTY Thermal Conductivity Specific Heat, 24 hrs. @ 25°C Linear Thermal Expansion Deflection Temperature at 264 psi	Btu-in/h-ft ² -°F Btu/lb/°F in/in/°F °F	3.100 2.5 x 10 ⁻⁵ >500	3.100 1.5 x 10 ⁻⁵ 505	2.2 x 10 ⁻⁵ 470	C177 C351 D696 D648-72	
ELECTRICAL PROPERTY Volume Resistivity, 2 min. Dielectric Strength Dielectric Constant, at 10 ³ Hz at 10 ⁶ Hz Dissipation Factor, at 10 ³ Hz at 10 ⁶ Hz	Ω/cm V/mil	4.5 x 10 ¹⁶ 450 3.9 3.8 .001 .0013			D257 D149 D150 D150	
UL INFORMATION Δ				NOT UL RECOGNIZED		
Min. Material Thickness		.015 .058 .125 .250				
Flammability Rating UL94		V-0 V-0 V-0 V-0				
Hot Wire Ignition		-- 300+ 300+ 300+				
High Amp Arc Ignition		-- 200+ 200+ 200+				
High Volt Track Rate		-- 19 20 20				

Δ See Page 1-44 for definitions of UL terms used in Section 1.

PLASTIC MOLDING MATERIAL (CONT)

POLYPROPYLENE (PP)

DESCRIPTION		REMARKS	PART NUMBER	CC	
MATERIAL	COLOR			LB	CU IN
Profax 6523/Tenite 4230A Profax 6523/Tenite 4230A Profax 6523/Tenite 4230A Profax 6523/Tenite 4230A Profax 6523/Tenite 4230A Profax 6523/Tenite 4230A Profax 6523/Tenite 4230A Profax 6523/Tenite 4230A Profax 6523NW/Tenite 4230A	Natural P-02005 Red 91391 White P-12016 Dark Gray 96332 Light Gray P-23013 Yellow 93976 Brown 96160 Green P-77004 Black 95662		254-0985-00 255-0041-00 255-0045-00 255-0223-00 255-0245-00 255-0272-00 255-0273-00 255-0274-00 254-0990-00	H J I J- I+ J J- I+ I+	B D- B+ C+ C D- C+ C C
PROPERTIES		UNIT OF MEASURE	PROFAX 6523A/ TENITE 4230A	ASTM TEST METHOD	
PHYSICAL PROPERTY Specific Gravity Mold Shrinkage Melting Point Water Absorption, 24 hrs.		in/in °F %	.903-.907 .009-.015 333 .010-.030	D792 D955 D570	
MECHANICAL PROPERTY Tensile Strength Elongation Tensile Modulus Flexural Modulus Impact Strength, Notched Izod Hardness, Rockwell		psi % psi psi ft.lb	5,000 10.900-12.900 210,000 274,000 .700 R100	D638 D638 D638 D638 D256	
THERMAL PROPERTY Linear Thermal Expansion Deflection Temperature at 66 psi at 264 psi		in/in/°F °F	5.8 x 10 ⁻⁵ 230 150	D864 D648	
ELECTRICAL PROPERTY Dielectric Strength, Short Time Dielectric Constant at 10 ³ Hz at 10 ⁶ Hz Dissipation Factor at 10 ³ Hz at 10 ⁶ Hz		V/mil	650 2.300 2.300 .0005 .0005	D149 D150 D150	
UL INFORMATION Δ Min. Material Thickness Flammability Rating UL94 Hot Wire Ignition High Amp Arc Ignition High Volt Track Rate			.040 .058 .120 HB HB HB -- -- 14 -- -- 200+ -- -- --		

PLASTIC MOLDING MATERIAL (CONT)

POLYPROPYLENE (PP)

1

DESCRIPTION		REMARKS	PART NUMBER	CC	
MATERIAL	COLOR			LB	CU IN
Tenite 4242A Tenite 4250A Tenite 4250A Tenite 4250A	Med. Gray Translucent 90522 Natural Blue 96638 Silver Gray P-96102	Extrusion Grade Injection Grade; Recommended for Hinges Injection Grade; Recommended for Hinges Injection Grade; Recommended for Hinges	255-0064-00 255-0502-00 255-0674-00 255-0335-00	J H J	D- B D-
PROPERTIES	UNIT OF MEASURE	TENITE 4242A	TENITE 4250A	ASTM TEST METHOD	
PHYSICAL PROPERTY Specific Gravity Melt Flow	g/10 min.	.902 9	.902 18	D1505 D1238L	
MECHANICAL PROPERTY Tensile Strength, yield Stiffness in Flexure Impact Strength, Izod Notched @ 23°C (73°F) Unnotched @ 23°C (73°F) Unnotched @ -18°C (0°F) Hardness, Rockwell	psi psi ft.-lb/in ft.-lb/in ft.-lb/in	5,000 160,000 .600 >16 4 R94	4,800 145,000 .500 >16 4 R92	D638 D747 D758	
THERMAL PROPERTY Vicat Soft Point Deflection Temperature at 264 psi	°F °F	291 135	289 135	D1525 D648	
UL INFORMATION Δ Min. Material Thickness Flammability Rating UL94		.050 HB	.120 HB		

Injection molding - melt temperature: 350° - 440°F (177° - 227°C)
 Extrusion - melt temperature: 440° - 450°F (232° - 288°C)

COST CODE (CC COLUMN)

CODE	A	B	C	D	E	F	G	H	I	J	K	L	M	N	O
≈ VALUE with +	.75¢	2¢	3.75¢	6¢	10¢	18¢	35¢	60¢	\$1	\$2	\$3.75	\$6	\$10	\$18	\$35+
≈ VALUE no suffix	.5¢	1.5¢	3¢	5¢	8¢	15¢	25¢	50¢	75¢	\$1.50	\$3	\$5	\$8	\$15	\$25
≈ VALUE with -	.2¢	1.25¢	2.5¢	4.25¢	7¢	13¢	22¢	40¢	65¢	\$1.25	\$2.50	\$4.25	\$7	\$13	\$22

NOTE: Costs may vary from order to order due to order quantities, vendor, etc.

PLASTIC MOLDING MATERIAL (CONT)

POLYSTYRENE (PS)

DESCRIPTION		REMARKS	PART NUMBER	CC	
MATERIAL	COLOR			LB	CU IN
Styrafil G-30/30 Styrafil G-30/30 Styron 6075 Thermocomp CF 1008-M	White 240 Black 219 Natural Black 8-013	30% Glass Filled 30% Glass Filled Flame Retardant; Surface Lubricated 40% Glass Filled	254-0965-00 254-0984-00 255-0791-00 255-0239-00	J- J I J-	D D+ C D+
PROPERTIES	UNIT OF MEASURE	STYRAFIL G-30/30	STYRON 6075	THERMOCOMP CF 1008-M	ASTM TEST METHOD
PHYSICAL PROPERTY Specific Gravity Mold Shrinkage Water Absorption, 24 hrs.	in/in %	1.280 .002 .070	1.160	1.380 .001 (.250 thk) .050	D792 D955 D570
MECHANICAL PROPERTY Tensile Strength, yield Tensile Strength, break Elongation Tensile Modulus Flexural Strength Flexural Modulus Impact Strength, Notched Izod Hardness, Rockwell	psi psi % psi psi psi ft.-lb/in	14,000 1,210,000 20,000 2.500 E53	3,200 3,500 45 290,000 6,500 2.200 L55	15,000 2-3 1,650,000 17,500 1,500,000 1.200 M93	D638 D638 D638 D638 D790 D790 D256 D785
THERMAL PROPERTY Linear Thermal Expansion Deflection Temperature at 66 psi at 264 psi	in/in/°F °F	2.19 x 10 ⁻⁵ 231 220	4.4 x 10 ⁻⁵	1.6 x 10 ⁻⁵ 235 220	D696 D648
ELECTRICAL PROPERTY Dielectric Strength, Short Time Dielectric Constant at 10 ³ Hz at 10 ⁶ Hz Dissipation Factor at 10 ³ Hz at 10 ⁶ Hz	V/mil	396 3.040 2.960 .001 .003	550 2.540 2.540		D149 D150 D150
UL INFORMATION Δ Flammability Rating UL94		NOT UL RECOGNIZED	V-0	NOT UL RECOGNIZED	

PLASTIC MOLDING MATERIAL (CONT)

POLYSTYRENE (PS)

DESCRIPTION		REMARKS	PART NUMBER	CC	
MATERIAL	COLOR			LB	CU IN
AMOCO R5C2	Clear		255-0001-00	H	B
PROPERTIES		UNIT OF MEASURE	AMOCO R5C2	ASTM TEST METHOD	
PHYSICAL PROPERTY					
Specific Gravity		dg/min (Method G)	1.050		D1238
Melt Flow		in/in	2.500		D955
Mold Shrinkage			.001-.006		
ASTM Cell Classification			1526B		
Water Absorption, 24 hrs.		%	.050		D570
MECHANICAL PROPERTY					
Tensile Strength, yield @ .200 in/min		psi	7,500		D638
Tensile Strength, break @ .200 in/min		psi	7,500		D638
Tensile Modulus		psi	500,000		
Flexural Modulus		psi			D790
2 in. span			520,000		
Impact Strength, Notched Izod @ 73°F		ft-lb/in	.500		D256
Hardness, Rockwell			M95		D785
THERMAL PROPERTY					
Thermal Conductivity		cal-cm/cm ² -°C-sec x 10 ⁴	2.400-3.300		
Specific Heat (at 73°F)		cal/°C/gm	.320-.350		
Linear Thermal Expansion		cm-°C/cm x 10 ⁵	6-8		D696
Vicat Soft Point		°F	221		
Deflection Temperature at 264 psi		°F	206		D648
ELECTRICAL PROPERTY					
Volume Resistivity		Ω/cm	>10 ¹⁶		D257
Dielectric Strength		V/mil	500-700		D149
Dielectric Constant at 10 ⁶ Hz			2.400-3.100		D150
Dissipation Factor at 10 ⁶ Hz			.0001-.005		
Arc Resistance		sec	60-80		
MOLDABILITY PARAMETERS					
Flow Length at 400°F; 600 psig		in	16		
Flow Length at 425°F; 900 psig		in	20		
Flow Length at 525°F; 900 psig		in	28		
Flow Length at 500°F; 1000 psig		in	24		
UL INFORMATION Δ					
Min. Material Thickness			.058 .096 .120		
Flammability Rating UL94			HB HB HB		
Hot Wire Ignition			23 30 --		
High Amp Arc Ignition			6 16 --		
High Volt Track Rate			1.3 1.3 --		

DESCRIPTION		REMARKS	PART NUMBER	CC	
MATERIAL	COLOR			LB	CU IN
Dylite F-40	White		255-0105-00	H	
PROPERTIES		UNIT OF MEASURE	DYLITE F-40	DYLITE F-133	ASTM TEST METHOD
Bulk Density		lb/ft ³	Raw 38	Expanded 1.500-2.000	34 1/16" dia, 1/8" long
Part Size Range			thru 10, on 20		
Sieve		in	.078 - .033	.238- .316	
Pellet Shape					Cylindrical
Volatile Content		%			5.000-6.500
Citric Acid Content		%			.250- .300
Extruded Density		lb/ft ³			3-10
UL INFORMATION					

Δ See Page 1-44 for definitions of UL terms used in Section 1.

PLASTIC MOLDING MATERIAL (CONT)

POLYSULFONE

DESCRIPTION		REMARKS	PART NUMBER	CC	
MATERIAL	COLOR			LB	CU IN
UDEL P-1700 UDEL P-1700NT	Black 935 Natural		255-0330-00 255-0719-00	L- L-	F+ F+
PROPERTIES	UNIT OF MEASURE	UDEL P-1700 & P-1700NT	ASTM TEST METHOD		
PHYSICAL PROPERTY Specific Gravity Mold Shrinkage Water Absorption, 24 hrs.	in/in %	1.240 .007 .300	D792 D955 D570		
MECHANICAL PROPERTY Tensile Strength, yield Elongation Tensile Modulus Flexural Strength Flexural Modulus Impact Strength, Notched Izod Hardness, Rockwell	psi % psi psi psi ft·lb/in	10,200 5-6 360,000 15,400 390,000 1.300 M69	D638 D638 D638 D790 D790 D256		
THERMAL PROPERTY Linear Thermal Expansion Deflection Temperature at 66 psi at 264 psi	in/in/°F °F	3.1×10^{-5} 358 345	D696 D648		
ELECTRICAL PROPERTY Dielectric Strength, Short Time Dielectric Constant at 10 ³ Hz at 10 ⁶ Hz Dissipation Factor at 10 ³ Hz at 10 ⁶ Hz	V/mil	425 3.100 3.030 .001 .0034	D149 D150 D150		
UL INFORMATION Δ Min. Material Thickness Flammability Rating UL94 Hot Wire Ignition High Amp Arc Ignition High Volt Track Rate		.058 .120 .240 V-2 V-2 V-0 21 63 91 6 14 16 6 0 1.2			

COST CODE

(CC COLUMN)

CODE	A	B	C	D	E	F	G	H	I	J	K	L	M	N	O
≈ VALUE with +	.75¢	2¢	3.75¢	6¢	10¢	18¢	35¢	60¢	\$1	\$2	\$3.75	\$6	\$10	\$18	\$35+
≈ VALUE no suffix	.5¢	1.5¢	3¢	5¢	8¢	15¢	25¢	50¢	75¢	\$1.50	\$3	\$5	\$8	\$15	\$25
≈ VALUE with -	.2¢	1.25¢	2.5¢	4.25¢	7¢	13¢	22¢	40¢	65¢	\$1.25	\$2.50	\$4.25	\$7	\$13	\$22

NOTE: Costs may vary from order to order due to order quantities, vendor, etc.

PLASTIC MOLDING MATERIAL (CONT)

POLYURETHANE (PUR)

1

DESCRIPTION		REMARKS	PART NUMBER	CC	
MATERIAL	COLOR			LB	CU IN
Estane 58810	Black 288	Elastomer-Ether	255-0337-00	J+	D+
Estane 58810	Natural	Elastomer-Ether	255-0370-00	K-	E+
Estane 58810	Yellow	Elastomer-Ether	255-0370-01	K	E+
Estane 58810	Dark Gray	Elastomer-Ether	255-0370-02	K-	E+
Estane 58880	Natural	Elastomer-Ether	255-0655-00	K	E+
Estane 58890	Natural	Elastomer; Flame Retardant	255-0621-01	K-	E+
PROPERTIES	UNIT OF MEASURE	ESTANE 58810	ESTANE 58880	ESTANE 58890	ASTM TEST METHOD
PHYSICAL PROPERTY					
Specific Gravity		1.140	1.100	1.280	D518
Specific Volume	lb/in ³	24.300			D518
Mold Shrinkage	in/in	.010-.015			D518
MECHANICAL PROPERTY					
Tensile Strength	psi	7,700	4,150		D638
Elongation at Break	%	540	600	420	D412 (2 in/min)
Elongation, Set	%	65		90	D412 (2 in/min)
Tear - Die C - pli		750	100		D624
Tear - Trouser - pli		470			D1938
Set after 100% Extension	%	10			D412 (2 in/min)
Tensile Modulus					D412 (2 in/min)
	10% psi	365			
	25% psi	670	440		
	50% psi	900	530		
	75% psi	1,070			
	100% psi	1,200	700	1,300	
	200% psi	1,850			
	300% psi	3,000	1,150	2,400	
Hardness, Shore		A92	A79	A90	D676
Compression Set, Method B	%				D395
22 hrs. at RT		20			
158°F		42			
212°F		60			
Tabor Abrasion gms loss, H-22 wheel	1000 gm load 5000 Rev	.024			D746
THERMAL PROPERTY					
Bell Brittle Point	°F	< 80	<-94	<-80	D395
Ozone Resistant (Procedures A, B, C)	1000 hrs, 50 pphm, 100°F	No effect			D518
ELECTRICAL PROPERTY					
Volume Resistivity at RT	Ω/cm	11. x 10 ¹²			D257
at 50°C		.700 x 10 ¹²			
500 VDC - 1 min at 70°C		.200 x 10 ¹²			
Dielectric Strength	V/mil	470			D149
Arc Resistance	Second	122			D495
Dielectric Constant					D150
at 60 Hz		6.000			
at 10 ³ Hz		5.590			
at 10 ⁶ Hz		4.210			
Dissipation Factor					D150
at 60 Hz		.048			
at 10 ³ Hz		.043			
at 10 ⁶ Hz		.075			
UL INFORMATION Δ					
Min. Material Thickness		NOT UL RECOGNIZED	NOT UL RECOGNIZED	.062 .125	
Flammability Rating UL94				V-2 V-0	

Δ See Page 1-44 for definitions of UL terms used in Section 1.

PLASTIC MOLDING MATERIAL (CONT)

POLYURETHANE (PUR)

DESCRIPTION		REMARKS			PART NUMBER		CC	
MATERIAL	COLOR						LB	CU IN
Estane 58013 Estane 58133 Thermocomp TF-100GHR	Black 288 Black Natural	Elastomer, Extrusion Grade Elastomer, Injection Grade 30% Glass Filled; Hydrolysis Resistant			255-0123-00 255-0262-00 255-0810-00	J+ J+ L-	E- E- F+	
PROPERTIES	UNIT OF MEASURE	ESTANE 58013	ESTANE 58133	THERMOCOMP TF-100GHR	ASTM TEST METHOD			
PHYSICAL PROPERTY Specific Gravity Mold Shrinkage Freeze Point, Gehman Low-Temperature Processing Stock Temperature Ozone Aging, 50 pphm, 20% Stretch, 120°F, for 144 hours Water Absorption, 24 hrs.	in/in °C °F %	1.210 -31 340-360 No Cracks	1.220 .008 350-370	1.460 .004 .200	D12-27 D1053 D1149-55T D570			
MECHANICAL PROPERTY Tensile Strength, yield Tensile Elongation Modulus at 300% Elongation Flexural Strength Flexural Modulus Elongation Graves Tear Compression Set, ASTM Meth. R 22 hours at 25°C 22 hours at 70°C NBS Abrasion, Method 14111, Federal Test Method Standard 601 (percent of Natural Rubber Standard) Taber Abrasion (mg loss) (CS17 wheel, 1000 gms wt., 5000 cycles) Impact Strength, Izod Notched at .250 in Unnotched at .250 in Hardness, Durometer	psi % psi psi psi % lb/in %	5,000 1,400 500 400 39 87 180 4 A88, C60	5,500 4,000 450 550 22 50 2.500 D55	8,200 25 5,600 240,000 6.800 37 D65	D412 D638 D790 D790 D624 D1229 D394 D1044-49T D676			
THERMAL PROPERTY Linear Thermal Expansion Brittle Temperature Deflection Temperature at 66 psi at 264 psi	in/in/°F °F °F	-100	-80	5.0 x 10 ⁻⁵ 315 170	D696 D746			
ELECTRICAL PROPERTY Dielectric Strength Dielectric Constant at 10 ³ Hz at 10 ⁶ Hz Dissipation Factor at 10 ³ Hz at 10 ⁶ Hz Insulation Resistance at 15.6°	V/mil Ω	740 4.520		560 5.610 4.690 .325 .422	D149			
UL INFORMATION Δ Flammability Rating UL94		NOT UL RECOGNIZED	NOT UL RECOGNIZED	HB				

PLASTIC MOLDING MATERIAL (CONT)

POLYURETHANE (PUR)

DESCRIPTION		REMARKS	PART NUMBER	CC	
MATERIAL	COLOR			LB	CU IN
Adiprene L-100* HT-112 Rigid Foam* Stayfoam Prepolymer MF 103* Urethane Rigid Foam System #555*	Natural Natural Natural Natural	Elastomer, Fluid; Extrusion Grade Casting Grade, Structural Foam Elastomer with Catalyst Casting Grade, Structural	006-1193-00 255-0383-00 252-0098-00 255-0410-00	K- J- I I+	

RUBBER (INJECTION MOLDING GRADE)

DESCRIPTION		REMARKS	PART NUMBER	CC				
MATERIAL	COLOR			LB	CU IN			
Hypalon* TPR-0932 TPR-1600 TPR-1610 TPR-1700 TPR-5290 TPR-5957	Black Natural Natural Black Black Natural Natural	Thermoplastic Elastomer Thermoplastic Elastomer Thermoplastic Elastomer Thermoplastic Elastomer Thermoplastic Elastomer Thermoplastic Elastomer	255-0544-00 255-0715-00 255-0515-00 255-0523-00 255-0616-00 255-0784-00 255-0716-00	K+ J I+ I+ I+ J- K+	C- C- C-			
PROPERTIES	UNIT OF MEASURE	TPR-0932	TPR-1600	TPR-1610	TPR-1700	TPR-5290	TPR-5957	ASTM TEST METHOD
PHYSICAL PROPERTY Specific Gravity			.880	1.010	.880			
MECHANICAL PROPERTY Tensile Strength, break Tensile Strength, yield Tensile Set at Break Elongation Tensile Modulus Compression Set, 22 hrs, at RT Hardness, Shore	psi psi % % psi %	1,800 530 A94	850 20 250 500 35	850 30 500 375 22	950 20 200 800 30	1,200 500 A85	1,500 700 A72	D412 & D638 D412 & D638 D412 D638 D412 D395B D2240
UL INFORMATION		NOT UL RECOGNIZED	NOT UL RECOGNIZED	NOT UL RECOGNIZED	NOT UL RECOGNIZED	NOT UL RECOGNIZED	NOT UL RECOGNIZED	

* Properties information not available.

Δ See Page 1-44 for definitions of UL terms used in Section 1.

PLASTIC MOLDING MATERIAL (CONT)

SILICONE (SI)

DESCRIPTION							PART NUMBER		CC	
MATERIAL	COLOR						REMARKS	LB	CU IN	
Dow Corning S2366U Dow Corning S2366U Dow Corning S2366U GE SE-436U GE SE-436U Modified GE SE-3808U GE SE-4404U S-2351U S 4702-0-Z*	Blue-Black Blue Black Natural Black Natural Natural Natural Black	Rubber, Elastomer, Fire Retardant Rubber, Elastomer, Fire Retardant Rubber, Elastomer, Fire Retardant Rubber, Elastomer Rubber, Elastomer Rubber, Elastomer Rubber, Elastomer Rubber, Elastomer Rubber, Elastomer					255-0776-00 252-0700-00 252-0700-01 255-0571-00 255-0520-00 255-0572-00 255-0472-00 255-0614-00 254-1000-00	N- M+ M- N- K M M	H H- G F- G+	
PROPERTIES	UNIT OF MEASURE	DOW CORNING S2366U	GE SE-436U	GE SE-436U MODIFIED	GE SE-3808U	GE SE-4404U	S-2351U	ASTM TEST METHODS		
PHYSICAL PROPERTY Specific Gravity		1.240	1.250		1.250	1.250	1.240			
MECHANICAL PROPERTY Tensile Strength Elongation Tear Strength - Die B Compression Set Hardness, Shore	psi % psi °F	1,300 570 200 10 A2, A53-60	1,100 700 170 30 A35	1,000 600-700 200 A40-50	1,100 130 95 25 A80	1,100 420 60 10 A50	1,300 600 190 8 A52	D412 D412 D624 D746		
THERMAL PROPERTY Brittle Temperature	°F	-98	-115		-85	-85	-98			
ELECTRICAL PROPERTY Resistivity	Ω/cm			<106						
UL INFORMATION Δ Min. Material Thickness Flammability Rating UL94		.075 V-1	NOT UL RECOGNIZED	NOT UL RECOGNIZED	NOT UL RECOGNIZED	NOT UL RECOGNIZED	NOT UL RECOGNIZED			

DESCRIPTION							PART NUMBER		CC	
MATERIAL	COLOR						REMARKS	LB	CU IN	
Dow Corning 308 Dow Corning 308	Black Black	Rigid 1" dia. x 15 gram Preform					255-0661-00 255-0408-00	L B- gram	G+	
PROPERTIES	UNIT OF MEASURE	DOW CORNING 308	ASTM TEST METHOD							
PHYSICAL PROPERTY Specific Gravity Water Absorption, 24 hrs.	%	1.880 .100	D792 D570							
MECHANICAL PROPERTY Tensile Strength, break Flexural Strength Flexural Modulus Compressive Strength Impact Strength, Notched Izod Hardness, Rockwell	psi psi psi psi ft-lb/in	6,000 8,000 1,200,000 12,000 .250 M80	D638 D790 D790 D695 D256 D648							
THERMAL PROPERTY Thermal Conductivity Linear Thermal Expansion -60° to 9°C 0° to 60°C 60° to 150°C 150° to 250°C Deflection Temperature at 264 psi Radiation Resistance (Megarads at 25°C scale)	Btu in/hr/ft ² °F in/in-°C x 10 ⁻⁵ °F	1.200 3.060 3.150 3.120 3.130 >518 2,000	D696 D648							
UL INFORMATION Δ Min. Material Thickness Flammability Rating UL94 Hot Wire Ignition High Amp Arc Ignition High Volt Track Rate		.062 V-0 300+ 200+ 0								

* Properties information not available.

PLASTIC MOLDING MATERIAL (CONT)

SILICONE (SI)

DESCRIPTION		REMARKS	PART NUMBER	CC	
MATERIAL	COLOR			LB	CU IN
Dow Corning 3140*	Clear	Rubber, Elastomer (Tube Form) RTV	252-0199-00	L Tube	
758*	Tan	Rubber, Elastomer, Shore A 60	252-0117-00	M-	
Dow Corning #96-079*		Resin	252-0214-00	K+	
Dow Corning #96-082*		Resin	252-0213-00	K+	
Eccosil 4952*		Rubber, w/catalyst #50 RTV	252-0261-00	N+ Each	
GE SE 5211*		Di-Cup-C Catalyst	252-0655-00	L	
UL INFORMATION Δ Min. Material Thickness Flammability Rating UL94		DOW CORNING 3140	DOW CORNING #96-082		
		.075	.060 V-0		

COST CODE

(CC COLUMN)

CODE	≈ VALUE with -	≈ VALUE no suffix	≈ VALUE with +
A	.2¢	.5¢	.75¢
B	1.25¢	1.5¢	2¢
C	2.5¢	3¢	3.75¢
D	4.25¢	5¢	6¢
E	7¢	8¢	10¢
F	13¢	15¢	18¢
G	22¢	25¢	35¢
H	40¢	50¢	60¢
I	65¢	75¢	\$1
J	\$1.25	\$1.50	\$2
K	\$2.50	\$3	\$3.75
L	\$4.25	\$5	\$6
M	\$7	\$8	\$10
N	\$13	\$15	\$18
O	\$22	\$25	\$35+

NOTE: Costs may vary from order to order
due to order quantities, vendor, etc.

* Properties information not available.

Δ See Page 1-44 for definitions of UL terms used in Section 1.

PLASTIC MOLDING MATERIAL (CONT)

VINYL (PVC)

1

DESCRIPTION		REMARKS	PART NUMBER	CC	
MATERIAL	COLOR			LB	CU IN
Geon 8812 Geon 8812 Geon 8813 Geon 8813 Geon 8813	Natural Black 288 Black 288 Natural 021 Green	Elastomer, Injection Grade Elastomer, Injection Grade Elastomer, Injection Grade Elastomer, Injection Grade Mixture of 255-0355-00 & 252-0192-00; Injection Grade	255-0566-00 255-0181-00 255-0212-00 255-0355-00 255-0356-00	H I+ H I K-	B+ C+ B+ C E+
Geon 8814 Geon 8814 Geon 8814	Black 288 White E132 Natural	Elastomer, Injection Grade Elastomer, Injection Grade Elastomer, Injection Grade	255-0208-00 255-0284-00 255-0435-00	I I+ A- Gram	C D-
PROPERTIES	UNIT OF MEASURE	GEON 8812	GEON 8813	GEON 8814	ASTM TEST METHOD
PHYSICAL PROPERTY Specific Gravity Emery Volatility Water Absorption, 24 hrs.	% %	1.240 -.390 .280	1.270 -.280 .230	1.320 .280 .230	D1203 D590
MECHANICAL PROPERTY Tensile Strength, break Elongation Tensile Modulus Clash Berg Stiffness Modulus of Rigidity at -35°C T _f Graves Tear Hardness, Shore Tensile 100% Modulus Volume Change	psi % psi psi °C psi psi psi psi %	1,500 400 500 4,700 -40 180 A65 1,600 620 -8.5	1,900 380 800 21,000 -40 250 A75 2,100 1,050 -8.5	2,400 310 1,300 46,000 -35 400 A85 2,500 1,850 -8.5	D638 D638 D638 D1004 D676 D573 D573
THERMAL PROPERTY Brittle Temperature Air Oven Aging 7 Days at 100°C	°F	-49	-37	-10	D746
ELECTRICAL PROPERTY Dielectric Strength	V/mil	690	750	850	D149
UL INFORMATION		NOT UL RECOGNIZED	NOT UL RECOGNIZED	NOT UL RECOGNIZED	

DESCRIPTION		REMARKS	PART NUMBER	CC		
MATERIAL	COLOR			LB	CU IN	
Geon 8800 Geon 8843 Geon 8870 Teknor-Apex 862	Natural Natural 021 Natural Natural	Extrusion Grade, Elastomer Extrusion Grade, Elastomer Extrusion Grade, Elastomer Extrusion Grade, Elastomer	255-0017-00 255-0130-00 255-0255-00 255-0460-00	I+ I+ I+ I+	D- D- C+ D-	
PROPERTIES	UNIT OF MEASURE	GEON 8800	GEON 8843	GEON 8870	TEKNOR-APEX 862	ASTM TEST METHOD
PHYSICAL PROPERTY Specific Gravity Stock Extrusion Temperature	°F	1.350	1.340 380-390	1.270 350-360	1.330 390-400	D792
MECHANICAL PROPERTY Tensile Strength, break Elongation Tensile Modulus at 100% elongation Hardness, Shore	psi % psi	3,000 250 C79	2,400 275 1,400 A91	2,000 300 900 A78	3,500 290 2,600 D63	D638 D638 D638
THERMAL PROPERTY Brittle Temperature Low Temp, flexibility	°F °F	14	-15 -15	-45		D746 UL83
ELECTRICAL PROPERTY Volume Resistivity Dielectric Strength Maximum Continuous Operation	Ω/cm V/mil	1.8 x 10 ¹² 700	1.0 x 10 ¹¹ 600 105	1.5 x 10 ⁹ 700 105	1.0 x 10 ¹⁴ 800 80	
UL INFORMATION		NOT UL RECOGNIZED	NOT UL RECOGNIZED	NOT UL RECOGNIZED	NOT UL RECOGNIZED	

PLASTIC MOLDING MATERIAL (CONT)

VINYL (PVC)

1

DESCRIPTION		REMARKS	PART NUMBER	CC	
MATERIAL	COLOR			LB	CU IN
Geon 8714	Black 288	Elastomer, Extrusion Grade	255-0299-00	H+	C-
PROPERTIES		UNIT OF MEASURE	GEON 8714	ASTM TEST METHOD	
PHYSICAL PROPERTY Specific Gravity			1.350	D792	
MECHANICAL PROPERTY Tensile Strength, break Tensile Modulus Flexural Strength Impact Strength, Notched Izod Shear Strength Hardness, Rockwell		psi psi psi ft·lb/in	6,100 340,000 11,500 15 Low R109	D638 D638 D790 D256	
THERMAL PROPERTY Deflection Temperature at 264 psi		°F	161	D648	
ELECTRICAL PROPERTY Volume Resistivity		Ω/cm	2.0×10^{12}		
UL INFORMATION			NOT UL RECOGNIZED		

DESCRIPTION		REMARKS	PART NUMBER	CC	
MATERIAL	COLOR			LB	CU IN
Geon 82024 Manner V95 or	Black 288 Black 580	Elastomer, Injection Grade	255-0403-00	J	D+
PROPERTIES		UNIT OF MEASURE	GEON 82024 or MANNER V95	ASTM TEST METHOD	
PHYSICAL PROPERTY Specific Gravity Water Absorption, 24 hrs.		%	1.190 .500	D792 D570	
MECHANICAL PROPERTY Tensile Strength, break Elongation Tensile Modulus Clash Berg Stiffness Modulus of Rigidity at -35°C Graves Tear Hardness, Shore		psi % psi psi lb/in	950 450 400 1,400 120 A50	D412 D412 D412 D1043 D1004 D676	
THERMAL PROPERTY Brittle Temperature		°F	-50	D746	
ELECTRICAL PROPERTY Dielectric Strength		V/mil	620	D149	
UL INFORMATION			NOT UL RECOGNIZED		

PLASTIC MOLDING MATERIAL (CONT)

VINYL (PVC)

DESCRIPTION		REMARKS	PART NUMBER	CC		
MATERIAL	COLOR			LB	CU IN	
Manner V-80 Manner V-80 Manner V-95 Teknor-Apex 838 Teknor-Apex 838 Teknor Apex CV-80	Medium Gray 530 Light to Medium Gray 565 Natural Slate Gray Black	Injection Grade Injection Grade Extrusion Compound Injection Grade	255-0114-00 255-0372-00 255-0482-00 255-0720-00 255-0813-00 255-0785-00	J- J- J+ I I+	D D E- . . E-	
PROPERTIES	UNIT OF MEASURE	MANNER V-80	MANNER V-95	TEKNOR-APEX 838	TEKNOR-APEX CV-80	ASTM TEST METHOD
PHYSICAL PROPERTY Specific Gravity		1.320	1.200		1.380	D792
MECHANICAL PROPERTY Tensile Strength, break Elongation Tensile Modulus Hardness, Shore	psi % psi	2,300 330 1,200 A86	850 450 350 A50	2,100 95 A75	1,580 150 C66	D638 D638 D638 D1706 & D2240
ELECTRICAL PROPERTY Volume Resistivity	Ω/cm			1.0×10^{13}		D257
UL INFORMATION		NOT UL RECOGNIZED	NOT UL RECOGNIZED	NOT UL RECOGNIZED	NOT UL RECOGNIZED	

EPOXY

DESCRIPTION		REMARKS	PART NUMBER	CC	
MATERIAL	COLOR			LB	CU IN
EMC #707 Hysol MG-17F Hysol MC-18 Hysol MG-20F 3M #251 or Equivalent Epoxy Coating	Clear Black	IC use Tanner for Epoxy 6612	255-0479-00 255-0406-00 255-0536-00 255-0830-00 252-0212-00 252-0153-00	I+ A Gram C Gram L- K- Gallon	

EPOXY RESINS

DESCRIPTION		REMARKS	PART NUMBER	CC	
MATERIAL	COLOR			LB	CU IN
Eccosorb CR-117 Epon 815 Essex Int #235 Essex Int #241 Stycast 2850 FT Stycast 2850 FT-FR Stycast 2850 GT 3M #281 or Equivalent	Blue Blue	High Thermal Conductivity (High Sink Use) w/Catalyst #11 w/Catalyst #11	255-0586-00 252-0041-00 252-0089-00 252-0077-00 255-0686-00 255-0731-00 252-0176-00 252-0210-00	M N+ Gallon K K- O+ Gallon K- N- Quart K-	

CURING AGENT

MATERIAL	PART NUMBER	CC
Triethylene Telramine for Epon 815-028	256-0558-00	H Ounce
Bis-amine A (Aromatic Diamine)	255-0762-00	K+ Pound

PLASTIC MOLDING MATERIAL (CONT)

PIGMENTS, COLOR CONCENTRATES AND OTHER ADDITIVES

1

MATERIAL	COLOR	LETDOWN RATIO	PART NUMBER	CC
ACETAL				
Celcon C-245 (Silicone Cone)	Natural	10:1	255-0680-00	A Gram
Reed C-PA-373	Gold	25:1	255-0563-00	B- Gram
Reed C-PA-375	Blue	25:1	255-0564-00	L+ Pound
Reed C-PA-377	Red	25:1	255-0562-00	L+ Pound
FLUOROCARBON				
Holar #17	Yellow	100:1	255-0817-00	
Holar #17 or 3	Orange	100:1	255-0818-00	
Holar #17-BK-4	Black	100:1	255-0819-00	
Holar #17-R-RD-4	Red	100:1	255-0820-00	
Holar	Blue	100:1	255-0828-00	
NYLON				
C-NY-969	Silver Gray	25:1	255-0462-00	L+ Pound
POLYCARBONATE				
DL-4040 (Silicone)	Natural	10:1	255-0692-00	K+ Pound
Reed C-PY-168	Jet Black	25:1	255-0613-00	L- Pound
POLYPROPYLENE/POLYPHENYLENE				
Teknor-Apex EPE 426	Black	20:1	252-0194-00	A- Gram
Teknor-Apex EPE 435	Brown	20:1	252-0194-01	A Gram
Teknor-Apex EPE 428	Red	20:1	252-0194-02	A Gram
Teknor-Apex EPE 434	Orange	20:1	252-0194-03	A Gram
Teknor-Apex EPE 427	Yellow	20:1	252-0194-04	A Gram
Teknor-Apex EPE 433	Green	20:1	252-0194-05	A Gram
Teknor-Apex EPE 432	Blue	20:1	252-0194-06	A- Gram
Teknor-Apex EPE 431	Violet	20:1	252-0194-07	A Gram
Teknor-Apex EPE 429	Gray	20:1	252-0194-08	A- Gram
Teknor-Apex EPE 430	White	20:1	252-0194-09	A- Gram
Tenite 1917A	Red		255-0188-00	H+ Pound
Merex 72-331	New Generation Gray	10:1	255-0448-00	L- Pound
Reed C-pur-209	Charcoal Gray	50:1	255-0452-00	K Pound
Wilson 16-BK-8	Black		255-0829-00	L Pound
POLYURETHANE				
Dupont	Gray 9200		255-0394-00	N Pound
Tefzel	Red 810		255-0511-00	J- Ounce
VINYL				
Avecor ACC 2434	Royal Blue	25:1	255-0561-00	K+ Pound
Avecor ACC 3516 V	Brick Red	25:1	255-0559-00	M- Pound.
Avecor ACC 4475	Gold	25:1	255-0560-00	A Gram
Teknor-Apex CS-1508-3	Green	50:1	252-0192-00	J Pound
Teknor-Apex CS-1509-3	White	50:1	252-0193-00	J- Pound
Teknor-Apex CS-993-3	Red	50:1	254-0937-00	K- Pound
Teknor-Apex 3000	Yellow	50:1	255-0430-00	A Gram
Teknor-Apex 5110	Brown	50:1	255-0434-00	I Pound
Teknor-Apex 2354-3	Tek Blue	50:1	255-0436-00	J+ Pound
Teknor-Apex 6020	Red	50:1	255-0476-00	J+ Pound
Teknor-Apex 3200	Orange	50:1	255-0513-00	I+ Pound
Teknor-Apex 1020	Gray	50:1	255-0517-00	J- Pound
Teknor-Apex CS-7337-3	Earth Brown	20:1	255-0809-00	J+ Pound
Teknor-Apex CS-7338-3	Slate Gray	20:1	255-0815-00	J+ Pound
Teknor-Apex CS-5200-3	Dark Gray	50:1	255-0027-00	J+ Pound
Teknor-Apex 4010	Blue	50:1	255-0578-00	J- Pound
Teknor-Apex CS-385-3F	Violet	50:1	255-0608-00	A- Gram
Teknor-Apex CS-6159-3	Yellow	50:1	255-0725-00	K- Pound
PIGMENT				
Ferro FC-7361	Medium Gray	100:1	252-0190-00	J+ Pound
Ferro FC-7379	Silver Gray	100:1	252-0196-00	K Pound
PMS 2131 LFD	Yellow		255-0774-00	K+ Pound
PMS 4700 LFD	Black	100:1	255-0570-00*	J+ Pound
CHEMICAL BLOWING AGENT				
Expandex OX-5PT			255-0553-00	M- Pound

*Can be used on all Thermoplastics.

UPDATES AND NOTES

1

§§ STATUS CODES

CR	Current Production
EN	Engineering
PP	Pre-Production
CS	Customer Service
NP	Non-Production
DL	Deleted
OB	Obsolete Instrument
CM	Custom Mod Instrument
DS	Digital Systems
OT	Obsolescent Instrument
MP	Modified Part
LR	Last Supply Current
LS	Last Supply Customer Service
VN	Vendor
TC	Tequipment Current Production
IN	International
SC	Sony/Tek Current Production

THE STATUS IN THIS CATALOG WAS CORRECT AT THE TIME IT WAS PUBLISHED, BUT IT IS SUBJECT TO CHANGE.

§ TO USE A PART WITH THIS STATUS ON A NEW INSTRUMENT REQUIRES THAT A NEW PURCHASED PART INITIATION FORM (PPIF) BE INITIATED.

(A GLOSSARY OF TERMS FOR THESE STATUS CODES CAN BE FOUND ON PAGE 0-10).

CROSS REFERENCE INDEX

PLASTIC MOLDING MATERIAL

1

PART NUMBER	GENERIC NAME	PAGE NO.	STATUS§§
006-1193-00	Polyurethane	1-33	CR
252-0041-00	Epoxy Resin	1-38	CR
252-0077-00	Epoxy Resin	1-38	CR
252-0089-00	Epoxy Resin	1-38	CR
252-0098-00	Polyurethane	1-33	CS
252-0117-00	Silicone	1-35	CR
252-0153-00	Epoxy	1-38	CS
252-0176-00	Epoxy Resin	1-38	CS
252-0190-00	Pigment	1-39	CS
252-0192-00	Vinyl (Color Concentrate)	1-39	CR
252-0193-00	Vinyl (Color Concentrate)	1-39	CR
252-0194-00	Polypropylene (Color Concentrate)	1-39	CR
252-0194-01	Polypropylene (Color Concentrate)	1-39	CR
252-0194-02	Polypropylene (Color Concentrate)	1-39	CR
252-0194-03	Polypropylene (Color Concentrate)	1-39	CR
252-0194-04	Polypropylene (Color Concentrate)	1-39	CR
252-0194-05	Polypropylene (Color Concentrate)	1-39	CR
252-0194-06	Polypropylene (Color Concentrate)	1-39	CR
252-0194-07	Polypropylene (Color Concentrate)	1-39	CR
252-0194-08	Polypropylene (Color Concentrate)	1-39	CR
252-0194-09	Polypropylene (Color Concentrate)	1-39	CR
252-0196-00	Pigment	1-39	CR
252-0199-00	Silicone	1-35	CR
252-0210-00	Epoxy Resin	1-38	CR
252-0212-00	Epoxy	1-38	CR
252-0213-00	Silicone	1-35	CR
252-0214-00	Silicone	1-35	CR
252-0261-00	Silicone	1-35	CR
252-0655-00	Silicone	1-35	CS
252-0700-00	Silicone	1-34	CR
252-0700-01	Silicone	1-34	PP
254-0922-00	CAB	1-9	CR
254-0923-00	CAB	1-9	CR
254-0925-00	Nylon (Polyamide)	1-16	CR
254-0937-00	Vinyl (Color Concentrate)	1-39	CR
254-0938-00	CAB	1-9	CR
254-0939-00	Polyethylene	1-22	CR
254-0940-00	Nylon (Polyamide)	1-16	CR
254-0965-00	Polystyrene	1-28	CR
254-0966-00	Polyethylene	1-22	CR
254-0979-00	Polycarbonate	1-19	CR
254-0984-00	Polystyrene	1-28	CR
254-0985-00	Polypropylene	1-26	CR
254-0987-00	Nylon (Polyamide)	1-16	CR
254-0990-00	Polypropylene	1-26	CR
254-0995-00	Nylon (Polyamide)	1-16	CR
254-0997-00	Polystyrene	CS	
254-0998-00	Acetal	1-5	CR
254-1000-00	Silicone	1-34	CR
255-0001-00	Polystyrene	1-29	CR
255-0007-00	Nylon (Polyamide)	1-16	CR
255-0009-00	ABS	1-8	CR
255-0010-00	Acetal	1-5	CR
255-0014-00	Acetal	1-5	CR
255-0015-00	ABS	1-8	CR
255-0017-00	Vinyl	1-36	CR
255-0018-00	Polyethylene	1-23	CR
255-0026-00	Nylon (Polyamide)	1-15	CR
255-0027-00	Vinyl (Color Concentrate)	1-39	CR
255-0033-00	Nylon (Polyamide)	1-16	CR
255-0041-00	Polypropylene	1-26	CR
255-0045-00	Polypropylene	1-26	CR
255-0050-00	Nylon (Polyamide)	1-16	CR
255-0061-00	Modified Acrylic	1-6	CS
255-0064-00	Polypropylene	1-27	CR
255-0071-00	Polyethylene	1-23	CR
255-0081-00	ABS	1-8	CR
255-0082-00	Polycarbonate	1-20	CR
255-0090-00	Acetal	1-5	CR
255-0095-00	ABS	1-8	CR
255-0099-00	Acrylic	1-6	CR
255-0100-00	Expandable Polystyrene	DL	
255-0105-00	Expandable Polystyrene	1-29	CR
255-0109-00	Acetal	1-5	CR
255-0110-00	Polyethylene	1-21	CR

PART NUMBER	GENERIC NAME	PAGE NO.	STATUS§§
255-0112-00	Polyethylene	1-22	CS
255-0113-00	ABS	1-8	CR
255-0114-00	Vinyl	1-38	CR
255-0115-00	Acetal		NP
255-0117-00	Nylon (Polyamide)	1-15	CR
255-0123-00	Polyurethane	1-32	CR
255-0130-00	Vinyl	1-36	CR
255-0134-00	ABS	1-8	CR
255-0140-00	Fluorocarbon	1-10	CR
255-0148-00	Phenolic	1-13	CR
255-0149-00	Polyethylene		NP
255-0156-00	Polycarbonate	1-20	CR
255-0160-00	Acetal	1-5	CR
255-0161-00	ABS	1-8	CR
255-0172-00	Nylon (Polyamide)	1-16	CR
255-0173-00	Acetal	1-5	CR
255-0173-01	Acetal	1-5	CR
255-0173-02	Acetal	1-5	CR
255-0173-03	Acetal	1-5	CR
255-0174-00	Acrylic	1-6	CR
255-0180-00	Acetal	1-5	CR
255-0181-00	Vinyl	1-36	CR
255-0188-00	Polyethylene (Color Concentrate)	1-22 & 1-39	CR
255-0189-00	Acetal	1-5	CR
255-0190-00	Acetal	1-5	CR
255-0197-00	Acetal	1-5	CR
255-0203-00	Polyphenylene Oxide	1-24	CR
255-0207-00	Acetal	1-5	CR
255-0208-00	Vinyl	1-36	CR
255-0212-00	Vinyl	1-36	CR
255-0214-00	Acetal	1-5	CR
255-0215-00	Polyethylene	1-21	CR
255-0217-00	Acetal	1-5	CR
255-0219-00	ABS	1-8	CR
255-0220-00	ABS	1-8	CR
255-0221-00	ABS		DL
255-0223-00	Polypropylene	1-26	CR
255-0225-00	Acrylic		NP
255-0227-00	Acetal	1-5	CR
255-0228-00	Acetal	1-5	CR
255-0229-00	Acetal	1-5	CR
255-0230-00	Acetal	1-5	CR
255-0231-00	Acetal	1-5	CR
255-0232-00	Acetal		OT
255-0233-00	Acetal	1-5	CR
255-0235-00	Polycarbonate	1-18	CR
255-0239-00	Polystyrene	1-28	CR
255-0240-00	Acetal	1-5	CR
255-0244-00	ABS	1-9	CR
255-0245-00	Polypropylene	1-26	CR
255-0255-00	Vinyl	1-36	CR
255-0262-00	Polyurethane	1-32	CR
255-0264-00	Polycarbonate	1-20	CR
255-0267-00	Polycarbonate	1-20	CR
255-0270-00	Polycarbonate	1-20	CR
255-0271-00	ABS	1-7	CR
255-0272-00	Polypropylene	1-26	CR
255-0273-00	Polypropylene	1-26	CR
255-0274-00	Polypropylene	1-26	CS
255-0282-00	Phenolic	1-13	CR
255-0284-00	Vinyl	1-36	CR
255-0285-00	Acetal	1-5	CR
255-0286-00	Polycarbonate	1-20	CR
255-0292-00	Polycarbonate	1-20	CR
255-0294-00	Nylon (Polyamide)	1-17	CR
255-0298-00	Polycarbonate	1-20	CR
255-0299-00	Vinyl	1-37	CR
255-0302-00	ABS	1-8	CR
255-0303-00	Nylon (Polyamide)	1-17	CR
255-0304-00	Polyethylene	1-23	CR
255-0308-00	Polycarbonate	1-18	CR
255-0312-00	ABS	1-8	CR
255-0313-00	ABS	1-8	CR
255-0317-01	Polycarbonate	1-20	CR
255-0318-00	Acrylic	1-6	CR

CROSS REFERENCE INDEX

PLASTIC MOLDING MATERIAL

PART NUMBER	GENERIC NAME	PAGE NO.	STATUS	PART NUMBER	GENERIC NAME	PAGE NO.	STATUS
255-0320-00	Acetal	1-5	CR	255-0504-00	Polycarbonate	1-18	CR
255-0327-00	Polycarbonate	1-20	CR	255-0505-00	Polyethylene	1-23	CR
255-0328-00	Modified Polyphenylene Oxide	1-24	CR	255-0507-00	Silicone		NP
255-0329-00	Nylon (Polyamide)		NP	255-0508-00	Polyethylene	1-22	CR
255-0330-00	Polysulfone	1-30	CR	255-0510-00	Fluorocarbon	1-10	CR
255-0332-00	Nylon (Polyamide)	1-17	CR	255-0511-00	Teflon (Color Concentrate)	1-39	CR
255-0335-00	Polypropylene	1-27	CR	255-0512-00	Teflon (Color Concentrate)		DL
255-0336-00	Polypropylene		DL	255-0513-00	Vinyl (Color Concentrate)	1-39	CR
255-0337-00	Polyurethane	1-31	CR	255-0515-00	Rubber	1-33	CR
255-0339-00	Polycarbonate	1-19	CR	255-0517-00	Vinyl (Color Concentrate)	1-39	CR
255-0355-00	Vinyl	1-36	CR	255-0520-00	Silicone	1-34	CR
255-0356-00	Vinyl	1-36	CS	255-0520-01	Silicone		DL
255-0359-00	Polyallomer	1-14	CR	255-0523-00	Rubber	1-33	CR
255-0364-00	Polycarbonate	1-20	CR	255-0527-01	Polycarbonate	1-20	CR
255-0365-00	Nylon (Polyamide)	1-16	CR	255-0532-00	Polycarbonate	1-18	CR
255-0368-00	Nylon (Polyamide)	1-17	CR	255-0536-00	Epoxy	1-38	CR
255-0370-00	Polyurethane	1-31	CR	255-0538-00	Polyphenylene Sulfide	1-25	CR
255-0370-01	Polyurethane	1-31	CR	255-0539-00	Nylon (Polyamide)	1-17	CR
255-0370-02	Polyurethane	1-31	CR	255-0540-01	Polycarbonate	1-20	CR
255-0372-00	Vinyl	1-38	CR	255-0542-00	Nylon (Polyamide)	1-15	CR
255-0374-00	Polyethylene	1-23	CR	255-0544-00	Rubber	1-33	CR
255-0376-00	ABS	1-8	CR	255-0548-00	Nylon (Polyamide)	1-15	CR
255-0378-00	Nylon (Polyamide)	1-17	CR	255-0549-00	Polyester		DL
255-0382-00	ABS	1-7	CR	255-0550-00	ABS	1-9	CR
255-0383-00	Polyurethane	1-33	CS	255-0553-00	Chemical Blowing Agent	1-39	CS
255-0384-00	Acrylic		OT	255-0559-00	Vinyl (Color Concentrate)	1-39	CR
255-0385-00	Acrylic	1-6	CR	255-0560-00	Vinyl (Color Concentrate)	1-39	CR
255-0386-00	Phenolic	1-13	CR	255-0561-00	Vinyl (Color Concentrate)	1-39	CR
255-0387-00	Nylon (Polyamide)	1-16	CR	255-0562-00	Acetal (Color Concentrate)	1-39	CR
255-0387-01	Nylon (Polyamide)	1-16	CR	255-0563-00	Acetal (Color Concentrate)	1-39	CR
255-0387-02	Nylon (Polyamide)	1-16	PP	255-0564-00	Acetal (Color Concentrate)	1-39	CR
255-0394-00	Teflon (Color Concentrate)	1-39	CR	255-0565-01	Polycarbonate	1-20	CR
255-0395-00	Teflon (Color Concentrate)		DL	255-0565-02	Polycarbonate	1-20	CR
255-0396-00	Teflon (Color Concentrate)		DL	255-0565-03	Polycarbonate	1-20	CR
255-0398-00	Silicone		NP	255-0565-04	Polycarbonate	1-20	CR
255-0403-00	Vinyl	1-37	CR	255-0565-05	Polycarbonate	1-20	CR
255-0405-00	Fluorocarbon	1-10	CR	255-0565-06	Polycarbonate	1-20	PP
255-0406-00	Epoxy	1-38	CR	255-0566-00	Vinyl	1-36	CR
255-0408-00	Silicone	1-34	CR	255-0570-00	Pigment	1-39	CR
255-0410-00	Polyurethane	1-33	CS	255-0571-00	Silicone	1-34	CR
255-0423-00	Polycarbonate	1-18	CR	255-0572-00	Silicone	1-34	CR
255-0430-00	Vinyl (Color Concentrate)	1-39	CR	255-0574-00	ABS	1-9	CR
255-0434-00	Vinyl (Color Concentrate)	1-39	CR	255-0574-01	Polycarbonate	1-20	CR
255-0435-00	Vinyl	1-36	CR	255-0578-00	Vinyl (Color Concentrate)	1-39	CR
255-0436-00	Vinyl (Color Concentrate)	1-39	CR	255-0582-00	Epoxy		DL
255-0438-00	Polycarbonate	1-19	CR	255-0586-00	Epoxy Resin	1-38	CR
255-0443-00	Polycarbonate	1-19	CR	255-0608-00	Vinyl (Color Concentrate)	1-39	CR
255-0444-00	Polycarbonate	1-19	CR	255-0612-00	Polycarbonate	1-18	CR
255-0445-00	Polycarbonate	1-19	CR	255-0612-01	Polycarbonate	1-18	CR
255-0446-00	Acrylic	1-6	CR	255-0612-02	Polycarbonate	1-18	CR
255-0447-00	ABS	1-7	CR	255-0612-03	Polycarbonate	1-18	CR
255-0448-00	Polyurethane (Color Concentrate)	1-39	CR	255-0612-04	Polycarbonate	1-18	CR
255-0452-00	Polyurethane (Color Concentrate)	1-39	CR	255-0613-00	Polycarbonate (Color Concentrate)	1-39	CR
255-0460-00	Vinyl	1-36	CR	255-0614-00	Silicone	1-34	CR
255-0461-01	Polypropylene		LR	255-0615-00	Modified Polyphenylene Oxide	1-24	CR
255-0462-00	Nylon (Color Concentrate)	1-39	CR	255-0616-00	Rubber	1-33	CR
255-0466-00	Methylpentene Polymer	1-12	CR	255-0617-00	Polycarbonate	1-18	CR
255-0469-00	Acetal	1-5	CR	255-0617-01	Polycarbonate	1-18	CR
255-0470-00	Polycarbonate	1-18	CR	255-0617-02	Polycarbonate	1-18	CR
255-0470-01	Polycarbonate	1-18	CR	255-0617-03	Polycarbonate	1-18	CR
255-0470-02	Polycarbonate	1-18	PP	255-0617-04	Polycarbonate	1-18	CR
255-0471-00	Nylon (Polyamide)	1-16	CR	255-0621-01	Polyurethane	1-31	CR
255-0472-00	Silicone	1-34	CR	255-0624-00	Polyphenylene Sulfide	1-25	CR
255-0473-00	Polycarbonate		LR	255-0625-00	Nylon (Polyamide)	1-15	CR
255-0476-00	Vinyl (Color Concentrate)	1-39	CR	255-0629-00	Acetal		NP
255-0479-00	Epoxy	1-38	CR	255-0634-00	Nylon (Polyamide)	1-15	CR
255-0482-00	Vinyl	1-38	CS	255-0644-00	ABS	1-8	CR
255-0483-00	ABS	1-7	CR	255-0644-01	ABS	1-8	CR
255-0488-00	Polycarbonate	1-19	CR	255-0644-02	ABS	1-8	CR
255-0488-01	Polycarbonate	1-19	CR	255-0644-03	ABS	1-8	CR
255-0488-02	Polycarbonate	1-19	CR	255-0644-04	ABS	1-8	CR
255-0488-03	Polycarbonate	1-19	CR	255-0644-05	ABS	1-8	CR
255-0488-04	Polycarbonate	1-19	CR	255-0644-06	ABS	1-8	CR
255-0488-05	Polycarbonate	1-19	CR	255-0646-00	Polyethylene	1-21	CR
255-0502-00	Polypropylene	1-27	CR	255-0651-00	Polycarbonate	1-20	CR

CROSS REFERENCE INDEX

PLASTIC MOLDING MATERIAL

PART NUMBER	GENERIC NAME	PAGE NO.	STATUS ^{§§}
255-0652-00	Polycarbonate	1-20	CR
255-0654-00	Polycarbonate	1-18	CR
255-0655-00	Polyurethane	1-31	CR
255-0661-00	Silicone	1-34	CR
255-0674-00	Polypropylene	1-27	CR
255-0680-00	Acetal (Color Concentrate)	1-39	CR
255-0682-00	ABS	1-8	OT
255-0683-00	ABS	1-8	CR
255-0684-00	Epoxy Resin		DL
255-0686-00	Epoxy Resin	1-38	CR
255-0688-00	Polycarbonate	1-19	CR
255-0692-00	Polycarbonate (Color Concentrate)	1-39	CR
255-0693-00	ABS	1-8	CR
255-0695-00	Polyphenylene Sulfide	1-25	OT
255-0696-00	Polycarbonate	1-18	CR
255-0700-00	Polycarbonate	1-18	CR
255-0701-00	ABS	1-8	CR
255-0710-00	Polycarbonate	1-18	CR
255-0715-00	Rubber	1-33	CR
255-0716-00	Rubber	1-33	CR
255-0719-00	Polysulfone	1-30	CR
255-0720-00	Vinyl	1-38	CR
255-0725-00	Vinyl (Color Concentrate)	1-39	PP
255-0731-00	Epoxy Resin	1-38	PP
255-0735-00	Polycarbonate	1-20	CR
255-0736-00	Polycarbonate	1-20	CR
255-0737-00	Polycarbonate	1-20	CR
255-0738-00	Polycarbonate	1-20	CR
255-0739-00	Polycarbonate	1-20	CR
255-0740-00	Polycarbonate	1-20	CR
255-0741-00	Polycarbonate	1-20	CR
255-0742-00	Polycarbonate	1-20	CR
255-0743-00	Polycarbonate	1-20	CR
255-0744-00	Polycarbonate	1-18	CR
255-0745-00	Nylon (Polyamide)	1-17	CR
255-0755-00	ABS	1-9	CR
255-0756-00	Polyphenylene Oxide	1-24	CR
255-0756-01	Polyphenylene Oxide	1-24	CR
255-0756-02	Polyphenylene Oxide	1-24	CR
255-0756-03	Polyphenylene Oxide	1-24	CR
255-0757-00	Polycarbonate	1-20	CR
255-0757-01	Polycarbonate	1-20	CR
255-0757-02	Polycarbonate	1-20	CR
255-0757-03	Polycarbonate	1-20	CR
255-0759-00	ABS	1-8	PP
255-0762-00	Curing Agent	1-38	CR
255-0764-00	Polyphenylene (Color Concentrate)		DL
255-0765-00	Polycarbonate (Color Concentrate)		DL
255-0766-00	Nylon (Polyamide)	1-16	PP
255-0767-00	ABS	1-9	CR
255-0771-00	Fluorocarbon	1-10	CR
255-0773-00	Polycarbonate	1-18	CR
255-0774-00	Pigment	1-39	CR
255-0776-00	Silicone	1-34	CR
255-0779-00	Polycarbonate	1-19	PP
255-0782-00	Fluorocarbon	1-11	PP
255-0783-00	Polycarbonate	1-20	CR
255-0784-00	Rubber	1-33	CR
255-0785-00	Vinyl	1-38	CR
255-0791-00	Polystyrene	1-28	CR
255-0804-00	Polycarbonate	1-18	CR
255-0809-00	Vinyl (Color Concentrate)	1-39	PP
255-0810-00	Polyurethane	1-32	CR
255-0811-00	ABS	1-8	CR
255-0812-00	ABS	1-9	CR
255-0813-00	Vinyl	1-38	CR
255-0814-00	Polycarbonate	1-20	CR
255-0815-00	Vinyl (Color Concentrate)	1-39	PP
255-0817-00	Fluorocarbon (Color Concentrate)	1-39	PP
255-0818-00	Fluorocarbon (Color Concentrate)	1-39	PP
255-0819-00	Fluorocarbon (Color Concentrate)	1-39	PP
255-0820-00	Fluorocarbon (Color Concentrate)	1-39	PP
255-0821-00	ABS	1-9	PP
255-0822-00	Nylon (Polyamide)	1-17	PP
255-0823-00	Polyphenylene Oxide	1-24	PP

PART NUMBER	GENERIC NAME	PAGE NO.	STATUS ^{§§}
255-0824-00	Polycarbonate	1-18	PP
255-0825-00	Polycarbonate	1-18	PP
255-0826-00	Polycarbonate	1-19	PP
255-0829-00	Polyurethane (Color Concentrate)	1-39	PP
255-0830-00	Epoxy	1-38	PP
256-0558-00	Curing Agent	1-38	CR

§§ STATUS CODES

CR	Current Production
⁶ EN	Engineering
PP	Pre-Production
⁶ CS	Customer Service
⁶ NP	Non-Production
⁶ DL	Deleted
⁶ OB	Obsolete Instrument
CM	Custom Mod Instrument
⁶ DS	Digital Systems
⁶ OT	Obsolescent Instrument
MP	Modified Part
LR	Last Supply Current
LS	Last Supply Customer Service
VN	Vendor
TC	Tequipment Current Production
IN	International
SC	Sony/Tek Current Production

THE STATUS IN THIS CATALOG WAS CORRECT AT THE TIME IT WAS PUBLISHED, BUT IT IS SUBJECT TO CHANGE.

⁵ TO USE A PART WITH THIS STATUS ON A NEW INSTRUMENT REQUIRES THAT A NEW PURCHASED PART INITIATION FORM (PPIF) BE INITIATED.

(A GLOSSARY OF TERMS FOR THESE STATUS CODES CAN BE FOUND ON PAGE 0-10).

UL INFORMATION

1

DEFINITION OF UL TERMS USED IN TEXT OF SECTION 1

HOT WIRE IGNITION -- THE NUMBER OF SECONDS NEEDED TO IGNITE STANDARD SPECIMENS WHICH ARE WRAPPED WITH RESISTANCE WIRE THAT DISSIPATES A SPECIFIED LEVEL OF ELECTRICAL ENERGY.

HIGH-AMPERE ARC IGNITION -- THE NUMBER OF ARC RUPTURE EXPOSURES WHICH ARE NECESSARY TO IGNITE A MATERIAL WHEN THEY ARE APPLIED AT A STANDARD RATE (EITHER ON THE SURFACE OF THE MATERIAL OR A SPECIFIED DISTANCE FROM IT).

HIGH-VOLTAGE ARC TRACKING RATE -- THE RATE (IN/MIN) THAT A TRACKING PATH CAN BE PRODUCED ON THE SURFACE OF THE MATERIAL UNDER STANDARDIZED CONDITIONS.

FLAMMABILITY -- MATERIALS ARE CLASSIFIED, BASED ON BURNING TESTS CONDUCTED IN ACCORDANCE WITH UL 94:

THE CLASSIFICATIONS ARE 94HB, 94V-2, 94V-1, OR 94V-0.

UL RECOGNIZED COMPONENT PLASTICS SHOULD BE USED IN NEW DESIGN AND REDESIGN WHENEVER POSSIBLE. WHEN CHOOSING A PLASTIC BE SURE THAT IT IS PROPERLY RATED FOR YOUR APPLICATION ACCORDING TO THE STANDARD APPROPRIATE FOR YOUR PRODUCT. FOR INFORMATION ON THE USE OF UL RECOGNIZED COMPONENT PLASTICS, CALL BERT HIPPE, PLASTICS, EXT. 7296 VANCOUVER, OR PRODUCT SAFETY, WALLY HOUSE, EXT. 7374.

CONDUCTIVE ELASTOMER SELECTION GUIDE

Many plastic compounds can be made electrically conductive by blending them with electrically conductive fillers such as graphite, metal powders, or carbon black. Pyrolyzed organic fibers derived from nylon, polyacrylonitrile, and pitch are combined with either thermosetting or thermoplastic compounds to impart conductivity. A loading of 0.5 percent in polyester sheet molding compounds, the pyrolyzed pitch will yield surface resistivities on the range of 30 to 50 ohms/sq.

Another approach to providing conductivity in non-conductive plastics is metallized fiberglass. The glass fibers have a deposited coating of nickel. The metal/fibers impart conductivity along with the strengthening of the plastic molding compound.

Epoxy conductive compounds often contain pure silver and are available as pastes in bulk or in collapsible tubes and as one component film forming systems. The room temperature curing pastes are useful in making connections where heat cannot be tolerated. It is also possible to use gold, palladium, platinum, and lower cost metals.

BULK

<u>MATERIAL DESCRIPTION</u>	<u>PROPERTIES/FEATURES</u>	<u>USAGE/AVAILABILITY</u>
(1) CARBON-SILICONE ELASTOMER	Silicone rubber with uniformly dispersed non-metallic conductive particles. Semi-conductive, resistivity is 7 to 10 ohm-cm (or up to 10^5 ohm-cm), depending on customer specifications.	Material comes in various extruded shapes and molded parts—strips, sheets, tubings, stamped parts, etc. Usage includes belts, rolls, gaskets, tubings, others.
(2) CARBON-POLYESTER	Volume-conductive material has an electrical conductance of 50,000 ohms (maximum). Humidity independent, it has high abrasion resistance, low affinity for water and good resistance to most acids and alkalis.	Available as a bulk material in films, sheets, blocks, rods, tubings. Used to make molds, or fabricated into special shapes.
(3) SILVER SILICONE & SILVER FLUOROSILICONE ELASTOMERS	Silicone or fluorosilicone binder with a filler of either pure silver or silver plated copper particles (pure silver particles are required for application with temperatures continuously above 125°C). Silver combined with silicone gives an unusually high RF attenuation with remarkable moisture and pressure seal. When application involves contact with hydraulic fluids, ozone, oils and chemical solvents, silver fluorosilicone is recommended. Resistivity range for various related grades is 0.003 to 0.018 ohm-cm.	Uses: Gaskets, seals, sensing devices, static charge components, etc. Available in many shapes and stamped parts. Also custom cut to specifications. Sheets and strips with or without pressure-sensitive adhesive backing.
(4) ALUMINUM WITH NEOPRENE OR SILICONE	Elastomer is of woven aluminum wire cloth impregnated with neoprene or silicone fluid sealing material.	Available in thin sheets from which intricate shapes can be cut.
(5) NICKEL-SILICONE ELASTOMER	Silicone rubber with a uniform dispersion of randomly oriented nickel fibers. Operating temperature: -54° to 232°C. Volume resistivity = 0.45 ohm-cm. It has an exceptional sealing property, corrosion resistance and is compatible with most metals and alloys.	Available in sheets, die-cut or stamped parts and shapes -- in black or metallic gray colors. Uses: Gaskets, contacting elements, conductive belts, static-charge components, and others.
(6) MONEL OR ALUMINUM WITH SILICONE	Similar to (3) and (4) in materials, but this elastomer is formed by critically expanding a fine metal foil and impregnating the expanded sheet with Silicone to seal.	For EMI/EMP gasketing grounding, bonding, and static discharge. Available in standard sheet sizes or larger in thin thicknesses.
(7) CONDUCTIVE FELT METAL WITH SILICONE	Elastomer is a sintered fiber metal felt produced in sheet form. Metal used is stainless steel (may also be phosphorous bronze or mild steel). Neoprene or butyl rubber may also be used for fillers. Material is recommended for low flange temperature range.	Used as conductive gaskets, ground vibration isolators, static dissipators, etc.

CONDUCTIVE ELASTOMER SELECTION GUIDE

1

PARTICLE-FILLED PRODUCTS

<u>MATERIAL DESCRIPTION</u>	<u>PROPERTIES/FEATURES</u>	<u>USAGE/AVAILABILITY</u>
(1) CONNECTOR BUTTONS/FRAMES	Conductive button connector can be molded in frames or rail or used individually. The resilient buttons are carbon or silver-filled silicone and this is molded in a dielectric carrier which may be glass-filled nylon or polyimide film.	Buttons are connectors for LDC's to PCB's, test and burn-in fixtures, etc. Molded in strips, connector buttons are used for interconnecting PCB's, flat cables, grounding devices, shock mounts, etc.
(2) SWITCH CONTACTS	Material is of silicone rubber filled with carbon or silver particles. Carbon-filled contacts have a resistance of <300 ohms-cm while the silver-filled ones give <0.30 ohms-cm resistance.	Material comes molded or extruded and sliced to any length. Standard sizes and shapes available but can be ordered to meet specifications.
(3) SEAL/SHIELD STRIPS	Commonly used are closed cell sponge, solid neoprene or silicone. Metals employed are Monel and Sn/Cu/Fe. Aluminum and silver plated brass are occasionally used.	Standard strips are available in 25-foot rolls but specific lengths with square and miter cut ends can be ordered. Thickness must be specified when ordering.
(4) TAPES/CLOSURES	Aluminum metal foil and metal-filled acrylate (with silicone release coated paper liner) transfer tapes are available. The conductive closure comes in two parts: One, the silver-impregnated nylon tape is covered with finely woven metal filaments formed into permanent hooks; the other covered with soft loops (pile). When pressed together, the two tapes provide a tight EMI/RFI seam. Either hook or pile may be used alone as a conductive resilient gasket.	Uses include: Closure tapes for mating joints, hinge covers, gaskets and in printers, copiers and computers
(5) CONDUCTIVE FOAM	Low density types: Antistatic Kincel, Aircap, Astro-Suprabubble and Pink Poly Foam. (Normal Density is 1 lb./ft ³ .) Meets ASTM D-257-66 STDS for surface resistivity. Hard density types: Carbon impregnated polyurethane or molded expanded polystyrene. (Normal density is up to 2.5 lb./ft ³ .) Meets MIL-P-26514.	Available in custom shaped, flat, die-cut or standard sheets. Light-density foams are available in rolls. Low-density foams are used for cushioning and packaging voltage sensitive devices or made into bags and pouches. High-density types are used for safe transport of MOS integrated circuits and other pinned devices.

CONDUCTIVE ELASTOMER SELECTION GUIDE

SURFACE-COATED MATERIALS

<u>MATERIAL DESCRIPTION</u>	<u>PROPERTIES/FEATURES</u>	<u>USAGE/AVAILABILITY</u>
(1) CONDUCTIVE FILMS	<p>A popular type is Pink Poly. Conductivity is brought about by a hygroscopic type of filler incorporated into a polyethylene matrix.</p> <p>Another type which comes opaque or transparent is a laminated polyester-polyethylene material with coating of nickel fibers on the film's surface.</p>	Available thicknesses are 3 to 6 mils. Used for wrappings, liners, table top covers, anti-static bags, etc.
(2) OPTICAL WINDOWS	<p>Optical panel materials commonly used are glass, acrylic, polycarbonate and fluoro-carbon plastics. The conductive transparent coating (may be graphite) is incorporated into the substrate's surface.</p> <p>Other materials available are Abcite, Mylar and Homalite.</p> <p>Note: The preipheries of these windows are terminated with a border of highly conductive, pure silver coated material. Use of conductive gasket is ideal for EMI/RFI shielding effectiveness.</p>	Windows are for optical displays and shielding. Polarized filter laminates are available as well as those with frosted and/or transparent finishes. Grids calibration rulings, characters and markings can be custom ordered.

CONDUCTIVE COMPOUNDS

<u>MATERIAL DESCRIPTION</u>	<u>PROPERTIES/FEATURES</u>	<u>USAGE/AVAILABILITY</u>
(1) ADHESIVE SEALANTS/EPOXIES	<p>Pure silver-loaded RTV liquid silicone rubber adhesive-sealant has a volume resistivity of 0.01 ohms-cm. It is fast drying and forms a firm, flexible resilient bond. (Some RTV adhesives use nickel carbon, aluminum, bronze, sponge iron and even gold fillers.) For high-temperature resistance with stronger and longer aging bond than the rubber adhesives (can be formulated to withstand UV rays, too) the acrylate and polyurethane adhesives are good to use.</p>	<p>Used for bonding, joining and repairing parts and joints, conductive seam sealant, etc.</p> <p>Some come as a two-compartment epoxy or as a regular one-compartment adhesive sealant in a dispenser tube.</p>
(2) CONDUCTIVE GREASE	<p>Usually silver silicone grease with no carbon or graphite fillers. Operating temperatures: -54° to 232°C, inert to ozone, radiation and most chemical compounds, and have excellent resistance to moisture and humidity.</p>	<p>Used to reduce friction resistance and noise. It can be applied by wiping or brushing.</p>
(3) CEMENT CAULKING SYSTEMS	<p>Copper and carbon free, it is usually made of a conductive plastic-polypropylene, polyurethane, and polyvinylacetate, or silicone in silver resin.</p>	<p>Caulking systems come with putty-like consistency and are readily applied with a caulking gun, spatula or syringe.</p> <p>Cements are similar to caulking systems except that they come in thicker paste form.</p> <p>Applications: Used in ferrite and pot cores, repair of PCB's, gaskets and shields, cables, tubings, others.</p>

CONDUCTIVE ELASTOMER SELECTION GUIDE

1

CONDUCTIVE TEXTILES

<u>MATERIAL DESCRIPTION</u>	<u>PROPERTIES/FEATURES</u>	<u>USAGE/AVAILABILITY</u>
(1) CONDUCTIVE TEXTILES	<p>Different types of materials are available: One is of a highly conductive silver metallized knit or woven nylon fabric. Laminated kinds are also available for special applications. Included in this type of fabric is a 0.50 mil pressure-sensitive polyester fiber which comes with a 0.001 mil clean nylon; a black conductive polyethylene; a pink antistatic nylon fabric; and a blend of 65 percent polyester, 34 percent cotton and 1 percent stainless steel fiber.</p> <p>For performance when exposed to environmental conditions, vinyl coated fabrics are also available.</p> <p>Note: These fabrics have a surface resistance of <10 ohms-cm; have a tensile strength of up to 125 psi, tear strength of 3.5 to 8 psi and withstand temperatures of -40° to 120°C.</p>	<p>The silver-metallized nylon comes in standard widths and thickness, and in white or silver gray colors only. Other types come in different solid colors. These materials are laundered the same as ordinary clothing.</p> <p>Uses: Aprons, lab coats, protective suits for high-voltage linement, shielding curtains, body contacts and electromedical sensors, etc.</p>

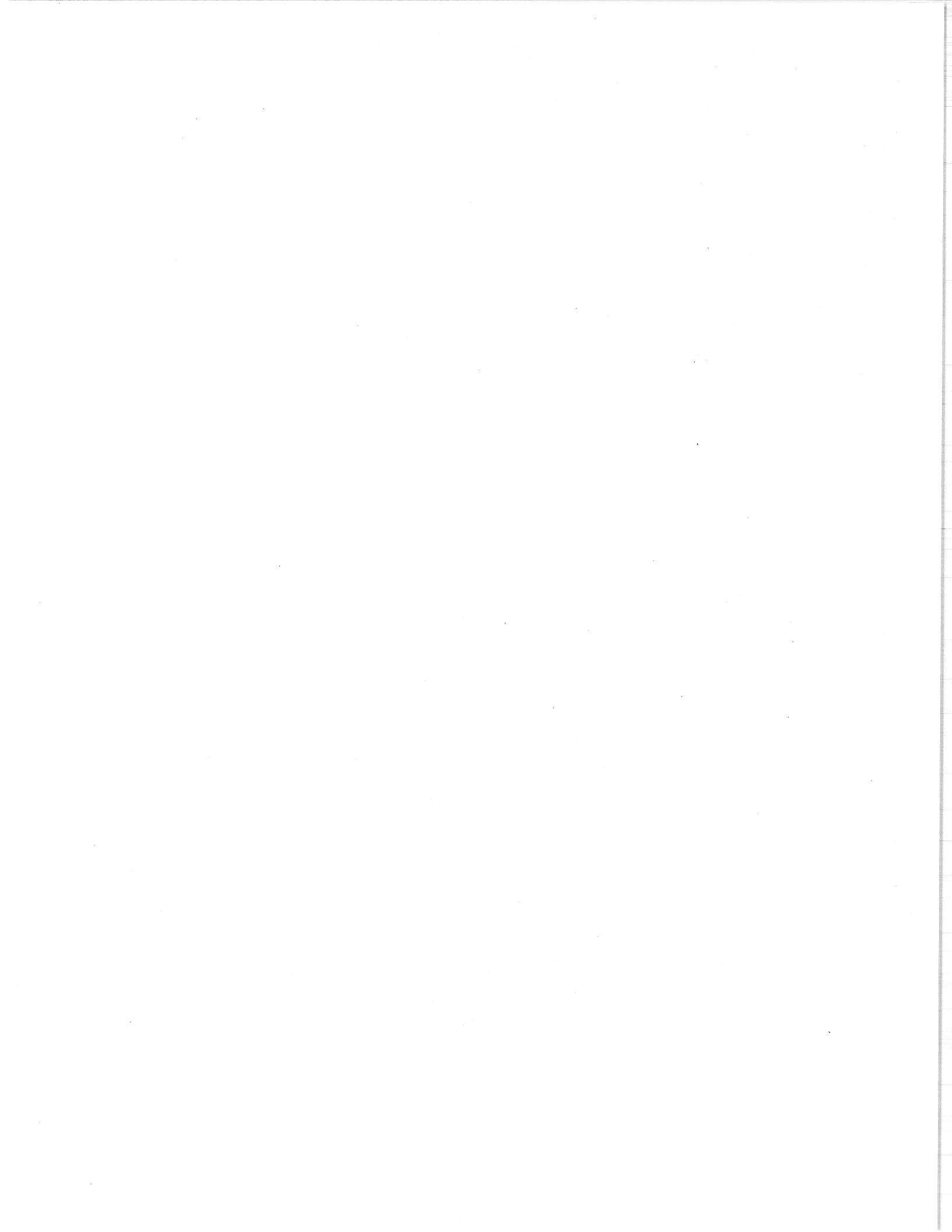

MATERIAL NAMES:

The standard used at Tek for naming parts is H6 (Cataloging Handbook). In some cases, the ASTM uses different names than H6. In such cases the H6 name will be used.

NAME	SHAPE
BAR	<p>(also Hex, Dodecagon, etc)</p> <p>≥.375 (≥9.525 mm)</p> <p>≥.375 (≥9.525 mm)</p> <p>≥.375 (≥9.525 mm)</p> <p>≥.375 (≥9.525 mm)</p> <p>≥.375 (≥9.525 mm)</p> <p>≥.375 (≥9.525 mm)</p> <p>.375 to 12" (9.525 to 304.8 mm)</p> <p>≥.094 (≥2.381 mm)</p>
ROD	DO NOT USE FOR METALS (Deleted from H6)
STRIP	<p>1.25 to 12" (31.75 mm to 304.8 mm)</p> <p>>.005 (>.132 mm)</p> <p><.094 (<2.381 mm)</p>
*WIRE & *ROD	<p>(also Hex, Dodecagon, etc)</p> <p><.375 (≥9.525 mm)</p> <p><.375 (≥9.525 mm)</p> <p><.375 (≥9.525 mm)</p> <p><.375 (≥9.525 mm)</p> <p><.375 (≥9.525 mm)</p> <p><.375 (≥9.525 mm)</p> <p><.250 (<31.75 mm)</p> <p>>.005 (>.132 mm)</p> <p><.094 (<2.381 mm)</p> <p>*Use WIRE for metal, and ROD for nonmetallic parts.</p>
SHEET	<p>>12" across narrowest flats. (>304.8 mm)</p> <p>>.005 (>.132 mm)</p>
FOIL & **FILM	<p>any width</p> <p>≤.005 (≤.132 mm)</p> <p>Use FOIL for metal, and FILM for nonmetallic parts.</p>

Some materials do not yet have specifications and may change without notice until the spec is finished. Also, some are exclusively used by one department and may be changed without notice by them.

PLASTIC (SHAPES AND SHEETS) AND FELT

SECTION 2

TABLE OF CONTENTS

	PAGE(S)
ROD	2-2
TUBING	2-3
STRIP	2-3
FILM	2-4 & 2-5
SHEET	2-5 THRU 2-7
ELECTRICAL INSULATING MATERIAL	2-8
FISH PAPER	2-8
FELT	2-8
PLASTIC CHANNEL	2-9 & 2-10
NOTES	2-11
CROSS REFERENCE INDEX	2-12 THRU 2-14

COST CODE

(CC COLUMN)

CODE	A	B	C	D	E	F	G	H	I	J	K	L	M	N	O
≈ VALUE with +	.75¢	2¢	3.75¢	6¢	10¢	18¢	35¢	60¢	\$1	\$2	\$3.75	\$6	\$10	\$18	\$35+
≈ VALUE no suffix	.5¢	1.5¢	3¢	5¢	8¢	15¢	25¢	50¢	75¢	\$1.50	\$3	\$5	\$8	\$15	\$25
≈ VALUE with -	.2¢	1.25¢	2.5¢	4.25¢	7¢	13¢	22¢	40¢	65¢	\$1.25	\$2.50	\$4.25	\$7	\$13	\$22

NOTE: Costs may vary from order to order due to order quantities, vendor, etc.

PLASTIC (SHAPED) ROD

2

ACETAL			
Delrin 500	Natural	.125 OD	255-0537-00 F+
Delrin 500	Natural	.250 OD	255-0159-00 F
Delrin 500	Black	.250 OD	255-0139-00 F+
Delrin 500	Natural	.375 OD	255-0062-00 G
Delrin 500	Black	.500 OD	255-0449-00 H-
Delrin 500	Natural	.500 thick x 1.000 wide	255-0734-00 G+
Delrin 500	Natural	.750 OD	255-0163-00 I+
Delrin 500	Black	.750 OD	255-0307-00 I
Delrin 500	Black (602)	1.000 OD	255-0528-00 J+
Delrin A/F (Fire Retardant)	Natural	1.000 OD	255-0421-00 L+
Delrin 500	Natural	1.125 OD	255-0704-00 K-
Delrin 500	Natural	2.000 OD	255-0463-00 L+
	Black	.250 thick x 2.500 wide	255-0763-00 K
	Natural	.500 thick x .500 wide	255-0770-00 J+
PHENOLIC			
Cotton-phenolic	Natural	.250 OD	254-0530-00 H-
Cotton-phenolic	Natural	.375 OD	254-0504-00 J-
Cotton-phenolic	Natural	.438 OD	254-0505-00 J
Paper-phenolic	Black	.500 OD	254-0507-00 K
NYLON (POLYAMIDE)			
Zytel 101	Natural	.188 OD ±.001	255-0116-00 E
Zytel 101	Natural	.188 OD	255-0276-00 E-
Zytel 101	Natural	.188 hex across flats	255-0278-00 G
Zytel 101	Natural	.250 OD	254-0948-00 B- (inch)
Nylatron GS MoS ₂ Filled	Black	.250 OD	255-0196-00 E+
Zytel 101	Natural	.312 OD	254-0949-00 B- (inch)
Zytel 101	Natural	.375 OD	254-0950-00 B+ (inch)
Zytel 101	White	.500 OD	254-0972-00 G+
Nylatron GS MoS ₂ Filled	Black	.500 OD	255-0029-00 H
Nylatron GS MoS ₂ Filled	Black	.562 OD	255-0108-00 I
Zytel 101	Natural	.625 OD	254-0951-00 D (inch)
Nylatron GS MoS ₂ Filled	Black	1.062 OD	255-0132-00 K-
POLYSTYRENE			
Polystyrene	Clear, Cross Linked	.125 OD	255-0753-00 I
Polystyrene	Clear	.188 OD	254-0914-00 A (inch)
Polystyrene	Clear, Cross Linked	.250 OD	255-0663-00 F+
Polystyrene	Clear	.250 OD	254-0915-00 B (inch)
Polystyrene	Clear	.312 OD	254-0917-00 C (inch)
Polystyrene	Clear, Cross Linked	.375 OD	255-0761-00 I+
Polystyrene	Clear	.375 OD	254-0916-00 B- (inch)
Polystyrene	Clear	.500 OD	254-0927-00 C- (inch)
Polystyrene	Clear, Cross Linked	.625 OD	254-0918-00 I+
Polystyrene	Clear, Cross Linked	1.500 OD	255-0104-00 L
FLUOROCARBON			
Teflon	Natural	.125 OD	255-0164-00 G
Teflon	Natural	.187 OD	255-0127-00 G
Teflon	Natural	.312 OD	254-0978-00 H+
Teflon	Natural	.375 OD	255-0028-00 I+
Teflon	Natural	.500 OD	255-0198-00 J
Teflon	Natural	.562 OD	255-0145-00 J
MISCELLANEOUS			
Acrylic		.500 OD	255-0786-00 I
Acrylic	Clear	1.000 OD	255-0787-00 J
Fiberglass	Green	.123	255-0345-00 G-
Fiberglass		.930	255-0171-00
Silicone Rubber		.062 x .094	252-0714-00 F- (each)

* Properties information for these materials can be found under their generic names in Section 1.

PLASTIC (SHAPED) (CONT) TUBING

MATERIAL	COLOR	DIMENSIONS (INCH)		PART NUMBER	CC/FT
		ID	OD		
PVC	Clear, Exelon 1060	.187	.372	255-0439-00	E-
Phenolic	Black	.250	.375	254-0519-00	C (inch)
Phenolic	Natural	.250	.500	254-0539-00	H+
Phenolic	Black	.625	.750	254-0527-00	C (inch)
Polyethylene	Natural		.250	255-0758-00	
Silicone Rubber			.062	252-0674-00	G
Urethane	Gray	.0625		255-0703-00	F-
Vinyl	Clear	.320	.395	255-0567-00	D

2

STRIP

DIMENSIONS (INCH)	DESCRIPTION	PART NUMBER	UNIT OF MEASURE	CC
.010 x 2.000	Fluorocarbon (Teflon®)	255-0032-00	Foot	G
.020 x .750	Fluorocarbon (Teflon®)	255-0020-00	Foot	G+
.062 x 1.000	Fluorocarbon (Teflon®)	255-0087-00	Foot	I
.063 x 1.250	Fluorocarbon (Teflon®)	255-0048-00	Foot	I-
.063 x 1.620	Fluorocarbon (Teflon®)	255-0078-00	Foot	I+
.063 x 1.750	Fluorocarbon (Teflon®)	255-0079-00	Foot	I
.063 x 2.430	Fluorocarbon (Teflon®)	255-0124-00	Foot	J-
.156 x .750	Silicone Rubber	252-0698-00	Foot	E+
1.500 wide	Blue Nylon Webbing	252-0611-00	Yard	F

COST CODE (CC COLUMN)

CODE	≈ VALUE with -	≈ VALUE no suffix	≈ VALUE with +
A	.2¢	.5¢	.75¢
B	1.25¢	1.5¢	2¢
C	2.5¢	3¢	3.75¢
D	4.25¢	5¢	6¢
E	7¢	8¢	10¢
F	13¢	15¢	18¢
G	22¢	25¢	35¢
H	40¢	50¢	60¢
I	65¢	75¢	\$1
J	\$1.25	\$1.50	\$2
K	\$2.50	\$3	\$3.75
L	\$4.25	\$5	\$6
M	\$7	\$8	\$10
N	\$13	\$15	\$18
O	\$22	\$25	\$35+

NOTE: Costs may vary from order to order
due to order quantities, vendor, etc.

PLASTIC (SHAPED) (CONT) FILM

2

DIMENSIONS (INCH)	DESCRIPTION	PART NUMBER	UNIT OF MEASURE	CC
POLYSTYRENE				
.0008 x .500	Clear	255-0388-00	Ounce	I
.0005 x .625	Clear	255-0121-00	Ounce	H+
.0005 x 1.000	Clear	255-0119-00	Pound	N
.00033 x .625	Clear	255-0144-00	Pound	N+
.00033 x 1.500	Clear	255-0178-00	Pound	N-
.00033 x 2.000	Clear	255-0118-00	Pound	O
.00025 x .625	Clear	255-0120-00	Pound	O
.00025 x 1.250	Clear	254-0654-00	Ounce	J+
.001 x .250	Clear	255-0419-00	Ounce	J-
.001 x .500	Clear	255-0122-00	Ounce	I
.001 x .620	Clear	255-0182-00	Pound	L+
POLYCARBONATE				
.0012 x .250	Clear	255-0257-00	Ounce	J
.0010 x .500	Clear	255-0155-00	Ounce	H-
.0008 x .500	Clear	255-0254-00	Ounce	L
.0005 x .250	Clear	255-0268-00	Ounce	J+
.0005 x .625	Clear	255-0133-00	Pound	O-
.0005 x 1.000	Metalized w/.062 Margin	255-0311-00	Pound	O
.0005 x 1.000	Clear	255-0456-00	Pound	N+
.0005 x 1.060	Clear	255-0206-00	Pound	O-
.0004 x 2.000	Clear	255-0202-00	Pound	N+
.00032 x .250	Clear	255-0258-00	Ounce	J
.00032 x .560	Clear	255-0455-00	Pound	N+
.00032 x 1.000	Clear	255-0475-00	Pound	N+
.00032 x 2.000	Clear	255-0204-00	Pound	N+
.00024 x .250	Clear	255-0659-00	Ounce	J+
.00024 x .375	Clear	255-0301-00	Ounce	J+
.00024 x .500	Clear	255-0152-00	Ounce	J-
.00024 x .625	Clear	255-0153-00	Ounce	J+
.00024 x 1.000	Crystallized	255-0199-00	Pound	L+
.00024 x 1.500	Clear	255-0151-00	Pound	N+
.00024 x 2.000	Clear	255-0205-00	Pound	O-
.0002 x .375	Aluminum Metalized	255-0366-00	Pound	O
.0002 x .375	Clear	255-0300-00	Ounce	J+
.0002 x .500	Clear	255-0506-00	Ounce	J
.0002 x .687	Clear	255-0147-00	Pound	O
.00014 x .375	Aluminum Metalized	255-0259-00	Ounce	L-
.00014 x .375	Clear	255-0433-00	Ounce	K
.00014 x 2.250	Aluminum Metalized	255-0425-00	Pound	O+
.00012 x .275	Clear	255-0660-00	Ounce	K+
.00012 x .625	Aluminum Metalized	255-0558-00	Pound	O+
.00012 x 1.060	Aluminum Metalized	255-0424-00	Pound	O+
.00008 x 1.000	Aluminum Metalized	255-0367-00	Pound	O+
.00008 x 1.500	Aluminum Metalized	255-0481-00	Pound	O+
.00008 x 2.250	Aluminum Metalized	255-0280-00	Ounce	L+
POLYESTER				
.005 x 2.406 x 6.984	Type A	162-0592-00	Each	F-
.0025 x .300	Clear w/Yellow	253-0304-00	Foot	A+
.0025 x .625	Clear w/Red	253-0298-00	Foot	C-
.001 x 1.000 x 17.000	Clear	254-0934-01	Each	H
.001 x .250	Clear	255-0555-00	Pound	K
.001 x .500	Clear	255-0031-00	Ounce	F
.0005 x .500	Clear	254-0646-00	Foot	A-
.0005 x .625	Clear	254-0956-00	Foot	A-
.0005 x .875	Clear	255-0075-00	Pound	K+
.00035 x 2.000	Clear	255-0093-00	Pound	K
.00035 x 2.250	Clear	255-0326-00	Pound	L+
.00025 x 1.500	Clear	255-0073-00	Pound	L+
.00025 x 2.200	Metalized	255-0011-00	Pound	M+
.00025 x 2.750	Clear	254-0946-00	Pound	K+
.0002 x 3.750	Clear	255-0432-00	Pound	N-

PLASTIC (SHAPED) (CONT) FILM (CONT)

2

DIMENSIONS (INCH)	DESCRIPTION	PART NUMBER	UNIT OF MEASURE	CC
POLYETHYLENE				
.004 x 38. x 48.		006-1793-00	Sheet	F+
.004 x 40. x 42.		006-1792-00	Sheet	F+
.0015 x 8. (16. inch extended)	Center folded, Industrial grade	006-0213-00	Pound	I
.0015 x 12. (24. inch extended)	Center folded, Industrial grade	006-0212-00	Pound	I
.0015 x 18. (36. inch extended)	Center folded, Industrial grade	006-0211-00	Pound	I
.0015 x 24. (48. inch extended)	Center folded, Industrial grade	006-1085-00	Pound	I-
MISCELLANEOUS				
.006 x 1. x 60. yards	Polyester/Hemp paper	253-0293-00	Foot	B+
.005 x 40. x 100. feet	Triacetate	006-1796-00	Sheet	G
.005 x 36. square	Epoxy Resin & Mica paper	252-0692-00	Square Inch	A-
.005 x 24. x 24.750	Triacetate	006-2841-00	Sheet	H
.005 x 7.500	Polyimide	255-0275-01	Pound	O+
.005 x 7.	Polyimide	255-0275-00	Pound	O+
.005 x 3.	Polyimide	255-0780-00	Pound	O+
.004 x 24.	Polyester/Asbestos paper	252-0687-00	Square Foot	G+
.004 x 20. x 26.	Vinyl, yellow w/adhesive back	255-0440-00	Sheet	H
.0025 x .437 x 36. yards	Polyimide	253-0297-00	Foot	E
.0025 x .150 x 36. yards	Polyimide	253-0308-00	Foot	D-
.002 x 24. x 30.	Polyvinyl fluoride; white	255-0533-03	Sheet	J
.002 x 24.	Polyvinyl fluoride; white	255-0533-01	Square Foot	F
.002 x 20. x 26.	Polyester w/matte aluminum w/adhesive back	253-0030-00	Square Inch	A-
.002 x 12. x 2500. feet	Polyvinyl fluoride; white	255-0533-00	Square Foot	E+
.002 x 12. x 20.	Polyvinyl fluoride; white	255-0533-02	Sheet	I
.002 x 9. x 12.	Mylar w/adhesive back	255-0319-00	Sheet	F
.002 x 8.	Polyimide	255-0535-00	Pound	O+
.002 x 2.5 x 10.950	Fluorocarbon (Teflon®)	255-0632-00	Each	G-
.001 x 1.	Polyester	254-0934-00	Pound	K-
.0005 x 12.	Teflon	255-0166-00	Square Inch	A-
.0005 x 1.062	Polypropylene	255-0587-00	Pound	N-
.00025 x .6875	Polypropylene; aluminum metalized	255-0653-00	Ounce	J+

SHEET

ACRYLIC

MATERIAL	CRT FILTER DATA		COLOR	DIMENSIONS (INCH)	PART NUMBER	UNIT OF MEASURE	CC
	PHOSPHOR	% TRANSMISSION**					
Plexiglas GM	P1, P39, Pe1	55	Green 2092	.030 x 38 x 50	255-0185-00	Sq Foot	K+
255-0185-00	P1, P39, Pe1	55	Green 2092	12 x 12	255-0185-01	Each	L-
Plexiglas GM	A11	30	Gray 2064	.030 x 38 x 50	255-0143-00	Sq Foot	K
255-0143-00	A11	30	Gray 2064	12 x 12	255-0143-01	Each	M-
Plexiglas GM			Amber 2516	.030 x 38 x 50	255-0187-00	Sq Foot	L-
Plexiglas GM			Colorless	.030 x 38 x 50	255-0141-00	Sq Foot	J
255-0141-00			Colorless	13 x 12	255-0141-01	Each	K
Plexiglas GM	P31	75	Blue 2069	.030 x 38 x 50	255-0305-00	Sq Foot	K
	P1, P2, P39	83					
	P11, P7						
Plexiglas GM	P7, P11	78	Blue 2152	.030 x 38 x 50	255-0186-00	Sq Foot	K+
Cal. Color Co. 410C			Red	.030 x 18 x 24	255-0618-00	Sq Inch	D-
Tec Satin		80	Deep Ruby Red	.030 x 18 x 24	255-0702-00	Sq Inch	B-
Plexiglas II UVA			Colorless	.060 x 36 x 60	254-0935-00	Sq Foot	K-
Plexiglas GM			Red 2423	.060 x 36 x 60	255-0442-00	Sq Foot	K
Plexiglas II			Green	.060 x 36 x 60	254-0911-00	Sq Inch	E+
Plexiglas GM	P1, P39, P31, P7	80	Aviation Green 2124	.030 x 38 x 50	255-0431-00	Sq Foot	K+
Polaroid HNCP 37	A11	30	Neutral (Non-glare)	.072 x 18 x 24	255-0325-00	Sheet	O+
Plexiglas II UVA			Colorless	.100 x 36 x 60	254-0944-00	Sq Inch	B
Plexiglas II UVA			White Frosted W-2447	.100 x 36 x 60	255-0126-00	Sq Foot	K
Plexiglas II UVA			White Translucent W-2447	.125 x 36 x 60	255-0503-00	Sq Foot	J+
Plexiglas II UVA			Colorless	.125 x 36 x 60	254-0907-00	Sq Inch	B+
Plexiglas GM	P1, P39, P31, P7	80	Aviation Green 2124	.125 x 36 x 60	255-0413-00	Sq Foot	J+
Plexiglas II UVA			Colorless	.187 x 36 x 60	254-0908-00	Sq Foot	K
Cal Color Co. 2423			Red 2423 (Non-glare)	.188 x 34 x 46	255-0691-00	Sq Foot	L
Plexiglas II UVA			Colorless	.250 x 36 x 60	255-0125-00	Sq Foot	L-
Plexiglas GM			Colorless	.500 x 36 x 48	255-0642-00	Sq Foot	M

** This is the percentage of light transmitted "through" the plastic sheet listed when used with the indicated phosphors.

PLASTIC (SHAPED) (CONT) SHEET (CONT)

CELLULOSE ACETATE BUTYRATE

MATERIAL	PHOSPHOR	% TRANSMISSION**	COLOR	DIMENSIONS (INCH)	PART NUMBER	UNIT OF MEASURE	CC
CAB	A11	30	Clear	.010 x 24 x 36	255-0224-00	Sq Inch	A-
Polaroid HNCP 37			Neutral	.030 x 6 x 6	255-0058-00	Each	L-
Polaroid NACP 24			Amber	.030 x 17 x 50	255-0237-00	Sq Inch	E-
CAB			Clear	.040 x 20 x 50	255-0310-00	Sheet	L-

2

ACRYLONITRILE-BUTADIENE-STYRENE

DESCRIPTION		DIMENSIONS (INCH)	PART NUMBER	UNIT OF MEASURE	CC
MATERIAL	COLOR				
ABS	Gray Haircell, Boltaron 6703	.030 x 35 x 72	254-0955-00	Square Inch	A-
ABS	Black	.030 x 53 x 88	255-0191-00	Square Foot	G+
ABS	Gray	.040 x 27 x 120	255-0459-00	Sheet	M-
ABS, Vinyl	Black	.042 x 15.810 x 25.180	107-0019-01	Each	J-
ABS		.047 x 32 x 62	255-0291-00*	Square Inch	A
ABS	Gray Haircell	.047 x 54 x 84	254-0647-00	Sheet	N
ABS	Black	.060 x 32 x 62	255-0397-00	Square Foot	J-
ABS	Gray Haircell, Self Extinguish	.060 x 53 x 88	255-0263-00	Pound	J
ABS	Gray Haircell, Black Matte	.080 x 36 x 72	255-0416-00	Sheet	N+
ABS	Light Gray	.120 x 32 x 62	255-0418-00	Sheet	O

PHENOLIC

DESCRIPTION		DIMENSIONS (INCH)	PART NUMBER	UNIT OF MEASURE	CC
MATERIAL	COLOR				
Phenolic	Natural	.031 x 18 x 24	006-2977-00	Sheet	J
Phenolic		.062 x 36 x 36	254-0510-00	Square Inch	A
Phenolic		.062 x 36 x 48	254-0509-00	Square Inch	A+
Phenolic		.062 x 39 x 48	254-0537-00	Pound	K-
Phenolic		.093 x 36 x 36	254-0531-00	Pound	K
Phenolic	Natural	.093 x 39 x 48	254-0536-00	Pound	K+
Phenolic		.125 x 36 x 36	254-0512-00	Square Inch	C-
Phenolic		.187 x 36 x 36	254-0534-00	Pound	K
Phenolic		.250 x 36 x 38	254-0547-00	Square Inch	D+
Phenolic		.312 x 36 x 48	255-0803-00	Sheet	O+
Phenolic	Black	.375 x 30 x 48	254-0514-00	Square Inch	B+
Phenolic		Natural	.500 x 36 x 36	254-0515-00	Square Inch

POLYURETHANE FOAM

DESCRIPTION		REMARKS	DIMENSIONS (INCH)	PART NUMBER	UNIT OF MEASURE	CC
MATERIAL	COLOR					
Polyurethane	Natural	4 pounds Density	.125 x 4 x 84	255-0670-00	Sheet	H
Polyurethane		Nickel plated	.125 x 7 x 8	252-0597-01	Each	L
Polyurethane	Dark Charcoal Gray	Electro-magnetic, energy absorbing	.125 x 10.5 x 50 feet	252-0589-00	Foot	E-
Polyurethane			.125 x 24 x 24	252-0636-00	Sheet	M+
Polyurethane			.125 x 48 x 72	252-0597-00	Sq. In	A-
Polyurethane	Charcoal Gray #1240	Self Adhesive	.250 x 18 x 48	252-0566-00	Sq. Ft	J+
Polyurethane		Scottfelt 5-900Z	.250 x 48 x 72	255-0551-00	Sheet	O+
Polyurethane		2 pounds Density	.250 x 54 x 76	252-0570-00	Sq. Ft	F
Polyurethane		Gray	.316 x 39 x 75	252-0559-00	Sq. In	A-
Polyurethane		Charcoal Gray #1240	2 pounds Density	.500 x 5 x 7	252-0568-00	Sq. In
Polyurethane	Charcoal	1.750 pound Density	.750 x 9.250 x 10.875	006-2987-00	Each	F-
Polyurethane			1.000 x 54 x 72	252-0560-00	Sq. In	A
Polyurethane			1.250 x 5.120 x 18	006-2832-00	Each	I+
Polyurethane			1.500 x 9.250 x 24	255-0514-00	Sheet	J+
Polyurethane			2.000 x 56 x 72	255-0486-00	Sheet	O
Polyurethane	Natural	Fire Retardant; 2 pounds Density	2.500 x 48 x 96	252-0591-00	Sq. In	A+

*This part number is also available in an optional size of 54 x 94.

PLASTIC (SHAPED) (CONT) SHEET (CONT)

POLYCARBONATE

DESCRIPTION		REMARKS	DIMENSIONS (INCH)	PART NUMBER	UNIT OF MEASURE	CC
MATERIAL	COLOR					
Polycarbonate	Clear	Lexan; Velvet text 1 side, matte other	.005 x 15.500 x 23.500	255-0775-00	Sheet	J
Polycarbonate	Clear		.010 x 15.500 x 23.500	255-0772-00	Each	I
Polycarbonate		Satin Clear Text; UV Stabilized	.010 x 24 x 500 feet	255-0679-00	Foot	H+
Polycarbonate	Natural	Clear, Optical	.020 x 24 x 48	255-0295-00	Sq. Ft	H-
Polycarbonate	Natural	Clear, Optical	.030 x 24 x 48	255-0371-00	Sq. Ft	I-
Polycarbonate	Natural	Clear, Optical	.060 x 48 x 96	255-0200-00	Sq. Ft	I+
Polycarbonate	Light Blue 8819-PBW Mobay	Transparent, Optical grade	.060 x 48 x 96	255-0645-00	Sq. Ft	J-
Polycarbonate	Natural	Clear	.125 x 48 x 96	255-0643-00	Sq. Ft	K-
Polycarbonate		Clear	.187 x 48 x 96	255-0664-00	Sq. Ft	J+

POLYESTER

DESCRIPTION		REMARKS	DIMENSIONS (INCH)	PART NUMBER	UNIT OF MEASURE	CC
MATERIAL	COLOR					
Polyester		Electrical grade	.010 x 5	255-0417-01	Roll	O+
Polyester		Pressure Sensitive, Adhesive one side	.010 x 9 x 12.500	255-0427-00	Sheet	H-
Polyester		Mylar Cover Sheet	.010 x 21.900 x 28.500	255-0808-00	Sheet	I+
Polyester		Electrical grade	.010 x 36 x 48	255-0417-00	Sheet	J+
Polyester			1.000 x 16 x 135	255-0573-00	Roll	O+

MISCELLANEOUS

DESCRIPTION		REMARKS	DIMENSIONS (INCH)	PART NUMBER	UNIT OF MEASURE	CC
MATERIAL	COLOR					
Acetal	Natural	Delrin® 500	.093 x 12 x 36	255-0807-00	Sheet	N
Acetal	Black		.375 x 12 x 12	255-0721-00	Sq. Ft	N
Acetal	White	Delrin®	.500 x 9 x 10	255-0805-00	Sheet	N+
Cellulose		Fibreboard; UL94 V-0	.032 x 39 x 41	252-0709-00	Sheet	L
Fluorocarbon (Teflon)	Natural		.030 x 24 x 24	255-0309-00	Sheet	O+
Hydrocarbon Foam			.250 x 48 x 48	254-0653-00	Sheet	O+
Neoprene		50 Durometer	.062 x 36	252-0506-00	Pound	J+
Neoprene Foam		Felt liner, Pressure Sensitive Adhesive	.485 x 1 x 36	252-0565-00	Foot	H-
Plastic	Clear	Paper liner, Pressure Sensitive Adhesive	9 x 12	002-0147-00	Sq. In	A-
Polyethylene			.025 x 24 x 24	252-0578-00	Sq. Ft	I-
Polyethylene Foam	Light Gray Volara		.625 x 48 x 60	255-0457-00	Sheet	N-
Polypropylene	Natural		.020 x 4 feet x 8 feet	255-0146-00	Sq. Ft	E+
Polystyrene	Translucent White	High Impact Commercial Grade	.020 x 18	255-0411-00	Sheet	I+
Polysulphone			.062 x 24 x 48	255-0575-00	Sheet	O+
Rubber		70 Durometer	.060 x 18 x 18	255-0177-00	Sq. In	F-
Rubber		Neoprene, 35-45 Durometer	.015 x 36	252-0555-00	Yard	L+
Silicone Rubber		w/Adhesive one side	.093 x 36 in sq.	252-0705-00	Sq. In	E-
Silicone Rubber			.125 x 12 x 18	252-0545-00	Sq. Ft	C-
Triacetate	Blue		.005 x 19 x 25	006-2979-00	Sheet	H-
Triacetate	Blue		.005 x 19 x 19	006-2980-00	Sheet	G
Vinyl	Clear		.0125 x 22	254-0960-00	Sq. In	A-
Vinyl	Clear	UL V-2	.0125 x 22	254-0960-03	Sq. In	A-
Vinyl	Black	Rigid	.030 x 20 x 50	255-0454-00		
Vinyl	Clear		.008 x 8.500 x 11	255-0760-00	Sheet	G-

2

PLASTIC (SHAPED) (CONT)

ELECTRICAL INSULATING MATERIAL

2

DIMENSIONS (INCH)	DESCRIPTION	PART NUMBER	UNIT OF MEASURE	CC
.001 x 24	Kraft Paper	252-0551-00	Pound	J+
.002 x 24	Kraft Paper	252-0516-00	Pound	J-
.003 x 24 x 36	Nomex Paper/Nylon #410	252-0617-00	Sheet	I
.004 x 24	Kraft Paper #1A775	252-0517-00	Pound	J-
.005 x .500	Fibremat I #2539 Uncoated, White	253-0123-00	Foot	B-
.005 x 1.000	Acetal, Delrin 900	253-0285-00	Foot	D
.005 x 1.000 x 300 feet	Crepe Paper, Untreated	252-0691-00	Foot	B-
.005 x 1.375	Kraft Paper #107	252-0524-00	Pound	I+
.005 x 1.500	Nomex Paper/Nylon #410	252-0688-00	Foot	C
.005 x 2.000	Fibremat I #2539 Uncoated, White	253-0068-00	Foot	B+
.005 x 24	Kraft Paper #30005	252-0518-00	Pound	J
.005 x 24 x 36	Nomex Paper/Nylon #410	252-0630-00	Sheet	J-
.0055 x .750	Fibremat I 2540 Polyester Reinforced, White	253-0020-00	Foot	B
.0055 x 2.250	Fibremat I #2540 Polyester Reinforced	253-0022-00	Foot	D+
.0055 x 3.000	Fibremat I #2540 Polyester Reinforced, White	253-0046-00	Foot	D+
.006 x .375	Fibremat IV Polyester Web/Film/Web, Yellow	253-0172-00	Foot	C-
.006 x .437	DMD100-2-2-2, Yellow	253-0181-00	Foot	C-
.006 x .500	DMD100-2-2-2, Yellow	253-0124-00	Foot	B+
.006 x .687	DMD100-2-2-2, Yellow	253-0159-00	Foot	B+
.006 x 1.000	DMD100-2-2-2, Yellow	253-0203-00	Foot	D
.006 x 1.250	Estermat, DM100	253-0258-00	Foot	C+
.006 x 1.437	DMD100-2-2-2, Yellow	253-0158-00	Foot	E-
.006 x 1.312	Estermat DM100	253-0265-01	Foot	D+
.006 x 1.500	Estermat DM100	253-0265-00	Foot	D
.006 x 1.875	DMD100-2-2-2, Yellow	253-0096-00	Foot	D+
.006 x 2.000	DMD100-2-2-2, Yellow	253-0081-00	Foot	E-
.006 x 2.250	DMD100-2-2-2, Yellow	253-0080-00	Foot	D+
.006 x 3.000	DMD100-2-2-2, Yellow	253-0082-00	Foot	E
.006 x 24	DMD100-2-2-2, Yellow	253-0127-00	Foot	I
.007 x 1.843	Fibremat III #2544 Polyester Reinforced, Yellow	253-0092-00	Foot	C-
.007 x 2.000	Fibremat III #2544 Polyester Reinforced, Yellow	253-0038-00	Foot	D
.007 x 2.250	Fibremat III #2545 Polyester Reinforced, Yellow	253-0025-00	Foot	C-
.007 x 24	Fibremat II Varnished Mat, Yellow	252-0532-00	Sq. Foot	H-
.007 x 24 x 36	Nomex Paper/Nylon #410	252-0633-00	Sheet	J+
.010 x 1.280	Custom Cuffed Rag Paper	252-0725-00	Foot	C+
.010 x 24 x 36	Nomex Paper/Nylon #410	252-0689-00	Sq. Inch	A-

FIBER SHEET (FISH PAPER)

DIMENSIONS (INCH)	REMARKS	PART NUMBER	UNIT OF MEASURE	CC
.005 x 24	Phenolic Impregnated	252-0537-00		
.015 x 1/4 sheet	Phenolic Impregnated	252-0523-00	Pound	J-
.020 x 25 x 42, Black	Phenolic Impregnated	252-0514-00	Pound	J+
.031 x 12 x 20	Phenolic Impregnated	006-3424-00	Sheet	I
.031 x 16 x 20	Phenolic Impregnated	006-2825-00	Sheet	I+
.031 x 25 x 42, Red	Phenolic Impregnated	252-0504-00	Pound	J+
.125 x 24 x 40, Gray	Phenolic Impregnated	252-0530-00	Pound	J+

FELT

DIMENSIONS (INCH)	COLOR	REMARKS	PART NUMBER	UNIT OF MEASURE	CC
.062 x 9.218 x 15.031	Blue #107		107-0021-00	Each	G+
.062 x 10.687 x 15.031	Blue #107		107-0022-00	Each	H-
.062 x 10.750 x 15.687	Blue #107		107-0023-00	Each	I
.062 x 14.437 x 15.031	Blue #107		107-0037-00	Sheet	I
.062 x 72	Black #200	50% Wool, 50% Rayon	252-0548-00	Sq. Inch	A-
.125 x 1.000 x 50 feet	Gray #8533	Pressure Sensitive Tape, one side	252-0511-00	Foot	F-
.187 x 1.000 x 78 feet	Gray #40		252-0512-00	Foot	B
14.000 x 35 to 40 yards	Blue #3425-39	100% Wool	252-0529-00	Yard	K

PLASTIC CHANNEL

THESE CHANNELS COME IN 100-FOOT ROLLS.

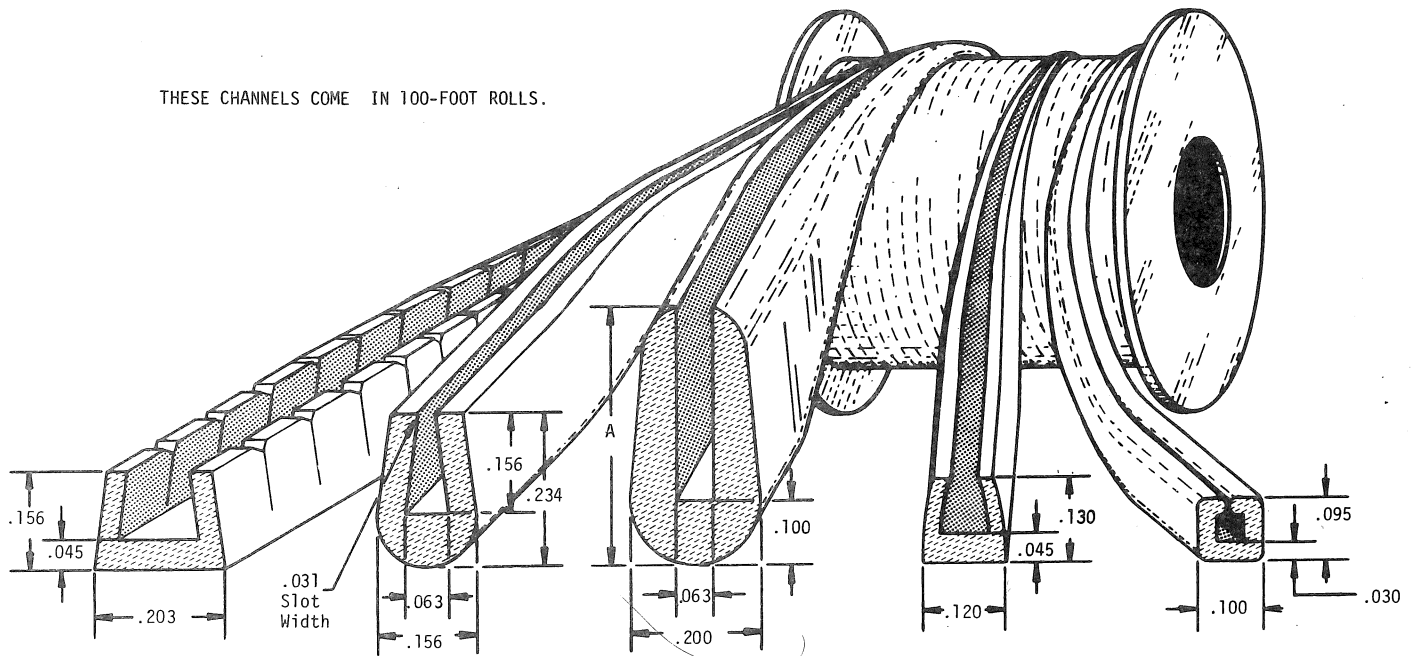

255-0619-00
CC: G+/FT NYLON
Panel Thickness: .106 to .164

252-0571-00
CC: G-/FT
BLACK NEOPRENE

252-0509-00 CC: G-/FT
Dim. A .400
BLACK RUBBER
255-0778-00 CC: F+/FT
Dim. A .313
BLACK PVC

252-0562-00
CC: D+/FT
NATURAL POLYETHYLENE

255-0713-00
CC: D+/FT
PVC

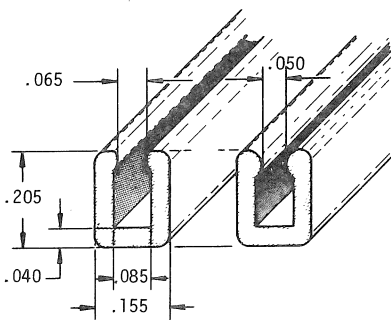

255-0412-00
CC: F+/FT
NATURAL VINYL
Random Lengths

255-0249-00
CC: D /FT
BLACK VINYL
Random Lengths

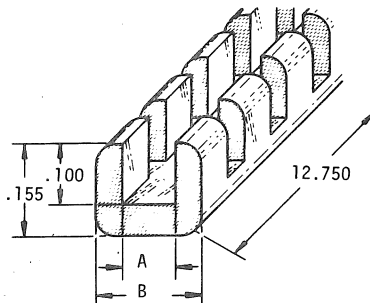

PART NUMBER	PANEL THKNS	MAT'L	CC	DIM A	DIM B
255-0334-00	.055 - .085	Nylon	F-/Ea	.090	.175
255-0806-00	.128 - .192	Nylon	G /Ea	.131	.220

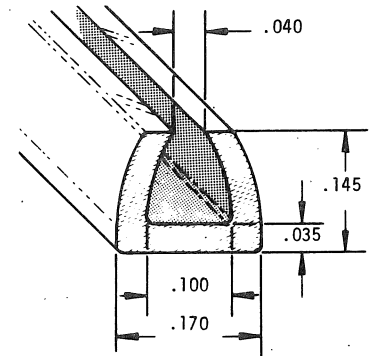

252-0564-00
CC: C-/FT
NATURAL POLYETHYLENE
Random Lengths

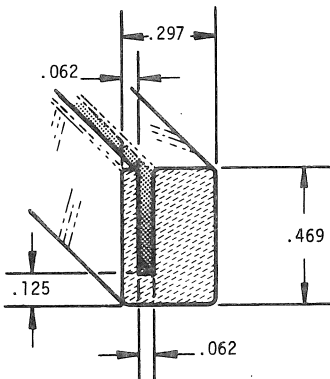

255-0648-00
CC: F /EA
BLACK NEOPRENE
11.0 to 11.125 in. long

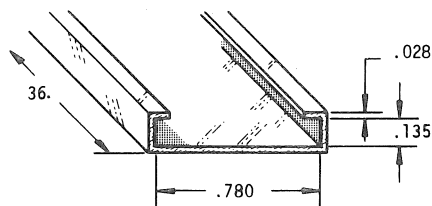

255-0450-00
CC: F-/FT
BLACK POLYETHYLENE

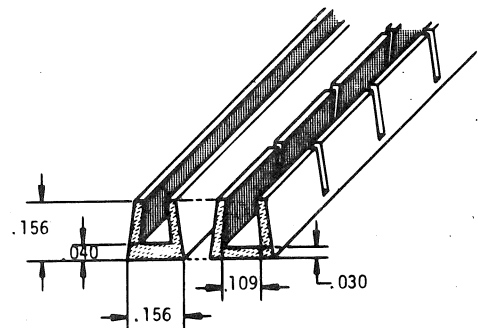

255-0581-00
CC: D+/FT
POLYETHYLENE
.037 to .050 Panel Thickness

255-0689-00
CC: R /FT
POLYETHYLENE
.037 to .105 Panel Thickness

PLASTIC CHANNEL MODULAR PACKAGING SYSTEM

2

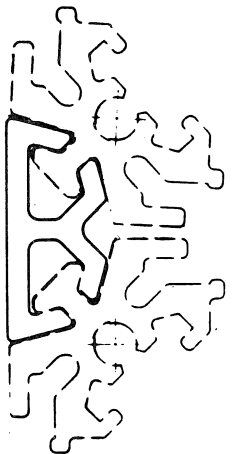

255-0631-XX

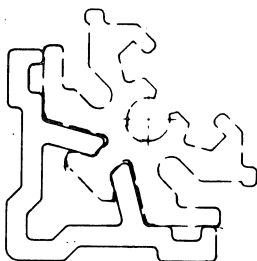

255-0733-00

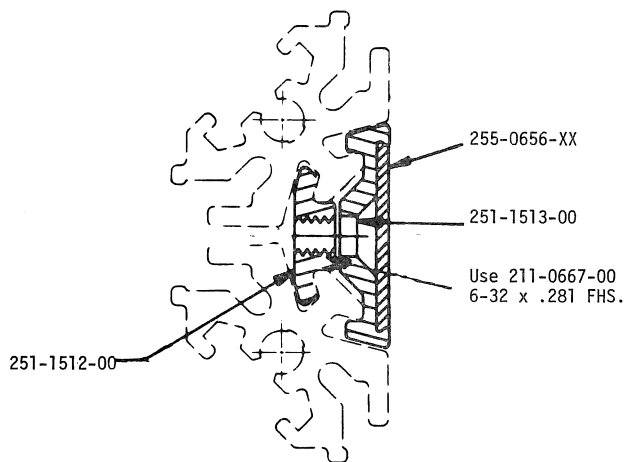

ALUMINUM CORNER EXTRUSION

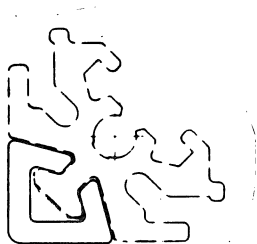

255-0630-XX

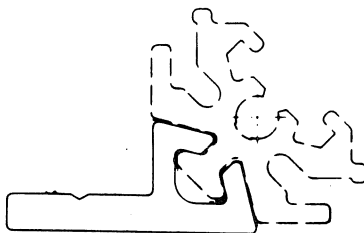

255-0714-XX

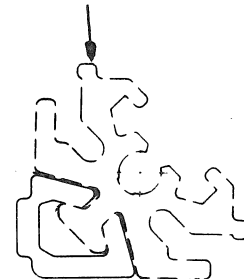

255-0717-XX

NOTE: See Pages 6-37 & 6-38 for Aluminum Extrusions.

255-0630-XX - This standard corner trim strip is used for most applications.

DESCRIPTION	COLOR	PART NUMBER	CC
Corner	Tek Blue	255-0630-00	F-
Corner	TV Gray	255-0630-01	F-
Corner	Tek Tan	255-0630-02	E+
Corner	Earth Brown	255-0630-03	E+

255-0631-XX - This extrusion's function is to lock two modules together, either side by side or top and bottom. It is slid onto the corner rails of two modules from the rear. No disassembly is needed.

DESCRIPTION	COLOR	PART NUMBER	CC
Interlock	Tek Blue	255-0631-00	F+
Interlock	TV Gray	255-0631-01	F+
Interlock	Tek Tan	255-0631-02	F+
Interlock	Earth Brown	255-0631-03	C-

255-0656-XX - This is a filler strip used on aluminum extrusion 251-1513-00 to conceal screwheads and give a finished appearance to the assembly.

DESCRIPTION	COLOR	PART NUMBER	CC
Interlock	Tek Blue	255-0656-00	E+
Interlock	TV Gray	255-0656-01	D+
Interlock	Tek Tan	255-0656-02	D+
Interlock	Earth Brown	255-0656-03	E+

255-0714-XX - This extrusion was designed to give customers the option of mounting their instruments to a surface (bench top, underside of shelf, etc.) by either the top, bottom, or side rails.

DESCRIPTION	COLOR	PART NUMBER	CC
Corner	Tek Blue	255-0714-00	F+
Corner	TV Gray	255-0714-01	F+
Corner	Tek Tan	255-0714-02	F+
Corner	Earth Brown	255-0714-03	F+

255-0717-XX - When the handle is on a side cover rather than the top cover, this extrusion can be used for the corner trim strips on the rails opposite the handle cover rails. The raised portion acts as a foot, protecting the aluminum corner rails from being scratched.

DESCRIPTION	COLOR	PART NUMBER	CC
Corner w/Step	Tek Blue	255-0717-00	F-
Corner w/Step	TV Gray	255-0717-01	F-
Corner w/Step	Tek Tan	255-0717-02	F-
Corner w/Step	Earth Brown	255-0717-03	F-

255-0733-00 - This extrusion is designed to serve as a protective strip, placed on the aluminum corner rails during instrument assembly, to keep them from being scratched or otherwise damaged.

If notched to clear the front casting, it will also protect the front castings finish.

DESCRIPTION	COLOR	PART NUMBER	CC
Corner Frame Protector	Natural	255-0733-00	F+

UPDATES AND NOTES

COST CODE

(CC COLUMN)

CODE	≈ VALUE with -	≈ VALUE no suffix	≈ VALUE with +
A	.2¢	.5¢	.75¢
B	1.25¢	1.5¢	2¢
C	2.5¢	3¢	3.75¢
D	4.25¢	5¢	6¢
E	7¢	8¢	10¢
F	13¢	15¢	18¢
G	22¢	25¢	35¢
H	40¢	50¢	60¢
I	65¢	75¢	\$1
J	\$1.25	\$1.50	\$2
K	\$2.50	\$3	\$3.75
L	\$4.25	\$5	\$6
M	\$7	\$8	\$10
N	\$13	\$15	\$18
O	\$22	\$25	\$35+

NOTE: Costs may vary from order to order due to order quantities, vendor, etc.

CROSS REFERENCE INDEX

PLASTIC (SHAPES & SHEETS) FELT AND PLASTIC CHANNEL

PART NUMBER	DESCRIPTION	PAGE NO.	STATUS§§	PART NUMBER	DESCRIPTION	PAGE NO.	STATUS§§
002-0147-00	Sheet, Plastic	2-7	CR	252-0714-00	Rod, Silicone Rubber	2-2	CR
006-0211-00	Film, Polyethylene	2-5	CR	252-0725-00	Electrical Insulating Material	2-8	PP
006-0212-00	Film, Polyethylene	2-5	CR	253-0020-00	Electrical Insulating Material	2-8	CR
006-0213-00	Film, Polyethylene	2-5	CR	253-0022-00	Electrical Insulating Material	2-8	CR
006-1085-00	Film, Polyethylene	2-5	CR	253-0025-00	Electrical Insulating Material	2-8	CS
006-1792-00	Film, Polyethylene	2-5	CR	253-0026-00	Electrical Insulating Material		DL
006-1793-00	Film, Polyethylene	2-5	CR	253-0030-00	Film, Polyester w/Matte Aluminum	2-5	CR
006-1796-00	Film, Triacetate	2-5	CR	253-0038-00	Electrical Insulating Material	2-8	CR
006-2206-00	Tubing, Tygon		DL	253-0046-00	Electrical Insulating Material	2-8	CR
006-2825-00	Fiber Sheet (Fish Paper)	2-8	CR	253-0068-00	Electrical Insulating Material	2-8	CS
006-2832-00	Sheet, Polyurethane Foam	2-6	CR	253-0080-00	Electrical Insulating Material	2-8	CR
006-2841-00	Film, Triacetate	2-5	CR	253-0081-00	Electrical Insulating Material	2-8	CR
006-2977-00	Sheet, Phenolic	2-6	CR	253-0082-00	Electrical Insulating Material	2-8	CR
006-2979-00	Sheet, Triacetate	2-7	CR	253-0092-00	Electrical Insulating Material	2-8	CS
006-2980-00	Sheet, Triacetate	2-7	CR	253-0096-00	Electrical Insulating Material	2-8	CR
006-2987-00	Sheet, Polyurethane Foam	2-6	CR	253-0123-00	Electrical Insulating Material	2-8	CR
006-3190-00	Sheet, Polystyrene		DL	253-0124-00	Electrical Insulating Material	2-8	CR
006-3424-00	Fiber Sheet (Fish Paper)	2-8	CR	253-0127-00	Electrical Insulating Material	2-8	CR
107-0019-01	Sheet, Acrylonitrile-Butadiene-Styrene	2-6	CR	253-0158-00	Electrical Insulating Material	2-8	CR
107-0021-00	Felt	2-8	CR	253-0159-00	Electrical Insulating Material	2-8	CR
106-0022-00	Felt	2-8	CR	253-0172-00	Electrical Insulating Material	2-8	CR
107-0023-00	Felt	2-8	CR	253-0181-00	Electrical Insulating Material	2-8	CR
107-0037-00	Felt	2-8	CR	253-0203-00	Electrical Insulating Material	2-8	CR
162-0592-00	Film, Polyester	2-4	CR	253-0231-00	Electrical Insulating Material		DL
252-0504-00	Fiber Sheet (Fish Paper)	2-8	CR	253-0258-00	Electrical Insulating Material	2-8	CR
252-0506-00	Sheet, Neoprene	2-7	CS	253-0265-00	Electrical Insulating Material	2-8	CR
252-0509-00	Plastic Channel	2-9	CS	253-0265-01	Electrical Insulating Material	2-8	CR
252-0511-00	Felt	2-8	CR	253-0285-00	Electrical Insulating Material	2-8	CR
252-0512-00	Felt	2-8	CS	253-0293-00	Film, Polyester/Hemp Paper	2-5	CR
252-0514-00	Fiber Sheet (Fish Paper)	2-8	CR	253-0297-00	Film, Polyimide	2-5	CR
252-0516-00	Electrical Insulating Material	2-8	CR	253-0298-00	Film, Polyester	2-4	CR
252-0517-00	Electrical Insulating Material	2-8	CR	253-0304-00	Film, Polyester	2-4	CR
252-0518-00	Electrical Insulating Material	2-8	CR	253-0308-00	Film, Polyimide	2-5	PP
252-0523-00	Fiber Sheet (Fish Paper)	2-8	CR	254-0504-00	Rod, Phenolic	2-2	CR
252-0524-00	Electrical Insulating Material	2-8	CR	254-0505-00	Rod, Phenolic	2-2	CR
252-0529-00	Felt	2-8	CR	254-0507-00	Rod, Phenolic	2-2	CR
252-0530-00	Fiber Sheet (Fish Paper)	2-8	CR	254-0509-00	Sheet, Phenolic	2-6	CR
252-0532-00	Electrical Insulating Material	2-8	CR	254-0510-00	Sheet, Phenolic	2-6	CS
252-0537-00	Fiber Sheet (Fish Paper)	2-8	CR	254-0512-00	Sheet, Phenolic	2-6	CR
252-0545-00	Sheet, Silicone Rubber	2-7	OB	254-0514-00	Sheet, Phenolic	2-6	CS
252-0548-00	Felt	2-8	CR	254-0515-00	Sheet, Phenolic	2-6	CR
252-0551-00	Electrical Insulating Material	2-8	CR	254-0519-00	Tubing, Phenolic	2-3	CS
252-0555-00	Sheet, Rubber	2-7	CR	254-0527-00	Tubing, Phenolic	2-3	OB
252-0559-00	Sheet, Polyurethane Foam	2-6	CS	254-0530-00	Rod, Phenolic	2-2	CS
252-0560-00	Sheet, Polyurethane Foam	2-6	CS	254-0531-00	Sheet, Phenolic	2-6	CS
252-0562-00	Plastic Channel	2-9	CR	254-0534-00	Sheet, Phenolic	2-6	CS
252-0564-00	Plastic Channel	2-9	CR	254-0536-00	Sheet, Phenolic	2-6	CS
252-0565-00	Sheet, Neoprene Foam	2-7	CR	254-0537-00	Sheet, Phenolic	2-6	CS
252-0566-00	Sheet, Polyurethane Foam	2-6	CR	254-0539-00	Tubing, Phenolic	2-3	CS
252-0568-00	Sheet, Polyurethane Foam	2-6	OT	254-0547-00	Sheet, Phenolic	2-6	CR
252-0570-00	Sheet, Polyurethane Foam	2-6	CR	254-0646-00	Film, Polyester	2-4	CR
252-0571-00	Plastic Channel	2-9	CR	254-0647-00	Sheet, Acrylonitrile-Butadiene-Styrene	2-6	CR
252-0578-00	Sheet, Polyethylene	2-7	CS	254-0653-00	Sheet, Hydrocarbon Foam	2-7	CR
252-0589-00	Sheet, Polyurethane Foam	2-6	CR	254-0654-00	Film, Polystyrene	2-4	CR
252-0590-00	Sheet, Polyurethane Foam		LS	254-0907-00	Sheet, Acrylic	2-5	CR
252-0591-00	Sheet, Polyurethane Foam	2-6	CR	254-0908-00	Sheet, Acrylic	2-5	CS
252-0594-00	Sheet, Silicone Rubber		DL	254-0911-00	Sheet, Acrylic	2-5	CS
252-0597-00	Sheet, Polyurethane Foam	2-6	CR	254-0914-00	Rod, Polystyrene	2-2	CS
252-0597-01	Sheet, Polyurethane Foam	2-6	CR	254-0915-00	Rod, Polystyrene	2-2	CR
252-0611-00	Strip, Nylon Webbing	2-3	CR	254-0916-00	Rod, Polystyrene	2-2	CS
252-0617-00	Electrical Insulating Material	2-8	CR	254-0917-00	Rod, Polystyrene	2-2	CR
252-0630-00	Electrical Insulating Material	2-8	CR	254-0918-00	Rod, Polystyrene	2-2	CR
252-0633-00	Electrical Insulating Material	2-8	CR	254-0919-00	Rod, Polystyrene		OB
252-0636-00	Sheet, Polyurethane Foam	2-6	CR	254-0927-00	Rod, Polystyrene	2-2	CS
252-0657-00	Sheet, Miscellaneous		DL	254-0934-00	Film, Polyester	2-5	CR
252-0674-00	Tubing, Silicone Rubber	2-3	CR	254-0934-01	Film, Polyester	2-4	CS
252-0687-00	Film, Polyester/Asbestos Paper	2-5	CR	254-0935-00	Sheet, Acrylic	2-5	CR
252-0688-00	Electrical Insulating Material	2-8	CS	254-0944-00	Sheet, Acrylic	2-5	CR
252-0689-00	Electrical Insulating Material	2-8	CS	254-0946-00	Film, Polyester	2-4	CR
252-0691-00	Electrical Insulating Material	2-8	CR	254-0948-00	Rod, Nylon	2-2	CR
252-0692-00	Film, Epoxy Resin & Mica Paper	2-5	CR	254-0949-00	Rod, Nylon	2-2	CR
252-0698-00	Strip, Silicone Rubber	2-3	CR	254-0950-00	Rod, Nylon	2-2	CR
252-0703-00	Rod, Silicone Rubber		DL	254-0951-00	Rod, Nylon	2-2	CR
252-0705-00	Sheet, Silicone Rubber	2-7	CR	254-0955-00	Sheet, Acrylonitrile-Butadiene-Styrene	2-6	CR
252-0709-00	Sheet, Cellulose	2-7	CR	254-0956-00	Film, Polyester	2-4	CR

CROSS REFERENCE INDEX

PLASTIC (SHAPES & SHEETS) FELT AND PLASTIC CHANNEL

2

PART NUMBER	DESCRIPTION	PAGE NO.	STATUS§§	PART NUMBER	DESCRIPTION	PAGE NO.	STATUS§§
254-0959-00	Tubing, Polystyrene		LS	255-0249-00	Plastic Channel	2-9	CR
254-0960-00	Sheet, Vinyl	2-7	CR	255-0254-00	Film, Polycarbonate	2-4	CR
254-0960-03	Sheet, Vinyl	2-7	CR	255-0257-00	Film, Polycarbonate	2-4	CR
254-0972-00	Rod, Nylon	2-2	CR	255-0258-00	Film, Polycarbonate	2-4	CR
254-0978-00	Rod, Fluorocarbon	2-2	CR	255-0259-00	Film, Polycarbonate	2-4	CR
255-0011-00	Film, Polyester	2-4	CR	255-0263-00	Sheet, Acrylonitrile-Butadiene-Styrene	2-6	CR
255-0020-00	Strip, Teflon	2-3	CR	255-0268-00	Film, Polycarbonate	2-4	CR
255-0028-00	Rod, Fluorocarbon	2-2	CR	255-0275-00	Film, Polyimide	2-5	CR
255-0029-00	Rod, Nylon	2-2	CR	255-0275-01	Film, Polyimide	2-5	CR
255-0031-00	Film, Polyester	2-4	CS	255-0276-00	Rod, Nylon	2-2	CR
255-0032-00	Strip, Teflon	2-3	CR	255-0278-00	Rod, Nylon	2-2	CR
255-0048-00	Strip, Teflon	2-3	OB	255-0280-00	Film, Polycarbonate	2-4	CR
255-0058-00	Sheet, Cellulose Acetate Butyrate	2-6	CS	255-0291-00	Sheet, Acrylonitrile-Butadiene-Styrene	2-6	CS
255-0062-00	Rod, Acetal	2-2	CR	255-0295-00	Sheet, Polycarbonate	2-7	CR
255-0073-00	Film, Polyester	2-4	CR	255-0300-00	Film, Polycarbonate	2-4	CR
255-0075-00	Film, Polyester	2-4	CR	255-0301-00	Film, Polycarbonate	2-4	CR
255-0078-00	Strip, Teflon	2-3	CS	255-0305-00	Sheet, Acrylic	2-5	CR
255-0079-00	Strip, Teflon	2-3	CS	255-0307-00	Rod, Acetal	2-2	CR
255-0087-00	Strip, Teflon	2-3	CR	255-0309-00	Sheet, Fluorocarbon	2-7	CR
255-0093-00	Film, Polyester	2-4	CR	255-0310-00	Sheet, Cellulose Acetate Butyrate	2-6	CS
255-0104-00	Rod, Polystyrene	2-2	CR	255-0311-00	Film, Polycarbonate	2-4	CS
255-0108-00	Rod, Nylon	2-2	CS	255-0319-00	Film, Mylar	2-5	CR
255-0116-00	Rod, Nylon	2-2	CR	255-0325-00	Sheet, Acrylic	2-5	CR
255-0118-00	Film, Polystyrene	2-4	CR	255-0326-00	Film, Polyester	2-4	CR
255-0119-00	Film, Polystyrene	2-4	CR	255-0334-00	Plastic Channel	2-9	CR
255-0120-00	Film, Polystyrene	2-4	CR	255-0345-00	Rod, Fiberglass	2-2	CR
255-0121-00	Film, Polystyrene	2-4	CR	255-0366-00	Film, Polycarbonate	2-4	CR
255-0122-00	Film, Polystyrene	2-4	CR	255-0367-00	Film, Polycarbonate	2-4	CR
255-0124-00	Strip, Teflon	2-3	CS	255-0371-00	Sheet, Polycarbonate	2-7	CR
255-0125-00	Sheet, Acrylic	2-5	CR	255-0388-00	Film, Polystyrene	2-4	CR
255-0126-00	Sheet, Acrylic	2-5	CR	255-0397-00	Sheet, Acrylonitrile-Butadiene-Styrene	2-6	CR
255-0127-00	Rod, Fluorocarbon	2-2	CR	255-0401-00	Sheet, Acrylic	OB	
255-0132-00	Rod, Nylon	2-2	CR	255-0411-00	Sheet, Polystyrene	2-7	CR
255-0133-00	Film, Polycarbonate	2-4	CR	255-0412-00	Plastic Channel	2-9	CR
255-0139-00	Rod, Acetal	2-2	CR	255-0413-00	Sheet, Acrylic	2-5	CR
255-0141-00	Sheet, Acrylic	2-5	CR	255-0416-00	Sheet, Acrylonitrile-Butadiene-Styrene	2-6	CS
255-0141-01	Sheet, Acrylic	2-5	CS	255-0417-00	Sheet, Polyester	2-7	CR
255-0143-00	Sheet, Acrylic	2-5	CR	255-0417-01	Sheet, Polyester	2-7	CR
255-0143-01	Sheet, Acrylic	2-5	OB	255-0417-02	Sheet, Polyester	DL	
255-0144-00	Film, Polystyrene	2-4	CS	255-0418-00	Sheet, Acrylonitrile-Butadiene-Styrene	2-6	CR
255-0145-00	Rod, Fluorocarbon	2-2	CR	255-0419-00	Film, Polystyrene	2-4	CR
255-0146-00	Sheet, Polypropylene	2-7	CR	255-0421-00	Rod, Acetal	2-2	CR
255-0147-00	Film, Polycarbonate	2-4	CR	255-0422-00	Rod, Vinyl	DL	
255-0150-00	Film, Polycarbonate	2-4	CR	255-0424-00	Film, Polycarbonate	2-4	CR
255-0151-00	Film, Polycarbonate	2-4	CR	255-0425-00	Film, Polycarbonate	2-4	CR
255-0152-00	Film, Polycarbonate	2-4	CR	255-0427-00	Sheet, Polyester	2-7	CR
255-0153-00	Film, Polycarbonate	2-4	CR	255-0431-00	Sheet, Acrylic	2-5	CR
255-0155-00	Film, Polycarbonate	2-4	CR	255-0432-00	Film, Polyester	2-4	CR
255-0159-00	Rod, Acetal	2-2	CR	255-0433-00	Film, Polycarbonate	2-4	CR
255-0163-00	Rod, Acetal	2-2	CR	255-0439-00	Tubing, PVC	2-3	CR
255-0164-00	Rod, Fluorocarbon	2-2	CR	255-0440-00	Film, Vinyl	2-5	CR
255-0166-00	Film, Teflon	2-5	CS	255-0442-00	Sheet, Acrylic	2-5	CR
255-0167-00	Film, Miscellaneous	OB		255-0449-00	Rod, Acetal	2-2	CR
255-0168-00	Sheet, Miscellaneous	OB		255-0450-00	Plastic Channel	2-9	CR
255-0171-00	Rod, Fiberglass	2-2	OB	255-0454-00	Sheet, Vinyl	2-7	CM
255-0177-00	Sheet, Rubber	2-7	CR	255-0455-00	Film, Polycarbonate	2-4	CR
255-0178-00	Film, Polystyrene	2-4	CS	255-0456-00	Film, Polycarbonate	2-4	CR
255-0182-00	Film, Polystyrene	2-4	CS	255-0457-00	Sheet, Polyethylene Foam	2-7	CR
255-0185-00	Sheet, Acrylic	2-5	CR	255-0459-00	Sheet, Acrylonitrile-Butadiene-Styrene	2-6	CR
255-0185-01	Sheet, Acrylic	2-5	CR	255-0463-00	Rod, Acetal	2-2	CS
255-0186-00	Sheet, Acrylic	2-5	CS	255-0475-00	Film, Polycarbonate	2-4	CR
255-0187-00	Sheet, Acrylic	2-5	CR	255-0481-00	Film, Polycarbonate	2-4	CR
255-0191-00	Sheet, Acrylonitrile-Butadiene-Styrene	2-6	CR	255-0486-00	Sheet, Polyurethane Foam	2-6	CR
255-0196-00	Rod, Nylon	2-2	CR	255-0503-00	Sheet, Acrylic	2-5	CR
255-0198-00	Rod, Fluorocarbon	2-2	CS	255-0506-00	Film, Polycarbonate	2-6	CR
255-0199-00	Film, Polycarbonate	2-4	CR	255-0514-00	Sheet, Polyurethane Foam	2-6	CR
255-0200-00	Sheet, Polycarbonate	2-7	CR	255-0521-00	Sheet, Polyurethane	DL	
255-0201-00	Film, Polycarbonate	CR		255-0528-00	Rod, Acetal	2-2	CR
255-0202-00	Film, Polycarbonate	2-4	CR	255-0533-00	Film, Polyvinyl Fluoride	2-5	CR
255-0204-00	Film, Polycarbonate	2-4	CR	255-0533-01	Film, Polyvinyl Fluoride	2-5	CR
255-0205-00	Film, Polycarbonate	2-4	CR	255-0533-02	Film, Polyvinyl Fluoride	2-5	CR
255-0206-00	Film, Polycarbonate	2-4	CR	255-0533-03	Film, Polyvinyl Fluoride	2-5	MP
255-0224-00	Sheet, Cellulose Acetate Butyrate	2-6	CR	255-0535-00	Film, Polyimide	2-5	CR
255-0237-00	Sheet, Cellulose Acetate Butyrate	2-6	CR	255-0537-00	Rod, Acetal	2-2	CR
255-0238-00	Rod, Polyimide		LR	255-0545-00	Sheet, Polyurethane Foam	DL	

§§FOR STATUS CODES, SEE PAGE 2-14.

CROSS REFERENCE INDEX

PLASTIC (SHAPES & SHEETS) FELT AND PLASTIC CHANNEL

PART NUMBER	DESCRIPTION	PAGE NO.	STATUS ^{§§}
255-0551-00	Sheet, Polyurethane Foam	2-6	PP
255-0552-00	Rod, Polyester		DL
255-0555-00	Film, Polyester	2-4	CR
255-0558-00	Film, Polycarbonate	2-4	CR
255-0567-00	Tubing, Vinyl	2-3	CS
255-0573-00	Sheet, Polyester	2-7	CS
255-0575-00	Sheet, Polysulfone	2-7	CR
255-0577-00	Sheet, Polycarbonate		DL
255-0581-00	Plastic Channel	2-9	CR
255-0587-00	Film, Polypropylene	2-5	CR
255-0618-00	Sheet, Acrylic	2-5	CR
255-0619-00	Plastic Channel	2-9	CR
255-0622-00	Sheet, Polycarbonate		NP
255-0630-00	Plastic Channel	2-10	CR
255-0630-01	Plastic Channel	2-10	CR
255-0630-02	Plastic Channel	2-10	CR
255-0630-03	Plastic Channel	2-10	CR
255-0631-00	Plastic Channel	2-10	EN
255-0631-01	Plastic Channel	2-10	EN
255-0631-02	Plastic Channel	2-10	PP
255-0631-03	Plastic Channel	2-10	EN
255-0632-00	Film, Fluorocarbon	2-5	CR
255-0642-00	Sheet, Acrylic	2-5	CR
255-0643-00	Sheet, Polycarbonate	2-7	CR
255-0645-00	Sheet, Polycarbonate	2-7	CR
255-0648-00	Plastic Channel	2-9	CR
255-0653-00	Film, Polypropylene	2-5	CR
255-0656-00	Plastic Channel	2-10	CR
255-0656-01	Plastic Channel	2-10	CR
255-0656-02	Plastic Channel	2-10	EN
255-0656-03	Plastic Channel	2-10	EN
255-0659-00	Film, Polycarbonate	2-4	OB
255-0660-00	Film, Polycarbonate	2-4	CR
255-0663-00	Rod, Polystyrene	2-2	CR
255-0664-00	Sheet, Polycarbonate	2-7	CR
255-0665-00	Sheet, Miscellaneous		OT
255-0670-00	Sheet, Polyurethane Foam	2-6	CR
255-0676-00	Rod, Nylon		DL
255-0679-00	Sheet, Polycarbonate	2-7	CR
255-0689-00	Plastic Channel	2-9	CS
255-0691-00	Sheet, Acrylic	2-5	CR
255-0702-00	Sheet, Acrylic	2-5	CR
255-0703-00	Tubing, Urethane	2-3	CR
255-0704-00	Rod, Acetal	2-2	CR
255-0705-00	Tubing, Silicone Rubber		DL
255-0711-00	Plastic Channel		CS
255-0713-00	Plastic Channel	2-9	CR
255-0714-00	Plastic Channel	2-10	EN
255-0714-01	Plastic Channel	2-10	
255-0714-02	Plastic Channel	2-10	
255-0714-03	Plastic Channel	2-10	
255-0717-00	Plastic Channel	2-10	PP
255-0717-01	Plastic Channel	2-10	EN
255-0717-02	Plastic Channel	2-10	PP
255-0717-03	Plastic Channel	2-10	CR
255-0718-00	Sheet, Vinyl		DL
255-0721-00	Sheet, Acetal	2-7	CR
255-0733-00	Plastic Channel	2-10	PP
255-0734-00	Rod, Acetal	2-2	PP
255-0753-00	Rod, Polystyrene	2-2	CR
255-0758-00	Tubing, Polyethylene	2-3	PP
255-0760-00	Sheet, Vinyl	2-7	PP
255-0761-00	Rod, Polystyrene	2-2	CR
255-0763-00	Rod, Acetal	2-2	CR
255-0770-00	Rod, Acetal	2-2	CR
255-0772-00	Sheet, Polycarbonate	2-7	PP
255-0775-00	Sheet, Polycarbonate	2-7	PP
255-0778-00	Plastic Channel	2-9	CR
255-0780-00	Film, Polyimide	2-5	CR
255-0786-00	Rod, Acrylic	2-2	CR
255-0787-00	Rod, Acrylic	2-2	PP
255-0803-00	Sheet, Phenolic	2-6	PP
255-0805-00	Sheet, Acetal	2-7	CM
255-0806-00	Plastic Channel	2-9	CR
255-0807-00	Sheet, Acetal	2-7	CR
255-0808-00	Sheet, Polyester	2-7	MP

§§ STATUS CODES

CR	Current Production
EN	Engineering
PP	Pre-Production
CS	Customer Service
NP	Non-Production
DL	Deleted
OB	Obsolete Instrument
CM	Custom Mod Instrument
DS	Digital Systems
OT	Obsolescent Instrument
MP	Modified Part
LR	Last Supply Current
LS	Last Supply Customer Service
VN	Vendor
TC	Tequipment Current Production
IN	International
SC	Sony/Tek Current Production

THE STATUS IN THIS CATALOG WAS CORRECT AT THE TIME IT WAS PUBLISHED, BUT IT IS SUBJECT TO CHANGE.

§ TO USE A PART WITH THIS STATUS ON A NEW INSTRUMENT REQUIRES THAT A NEW PURCHASED PART INITIATION FORM (PPIF) BE INITIATED.

(A GLOSSARY OF TERMS FOR THESE STATUS CODES CAN BE FOUND ON PAGE 0-10).

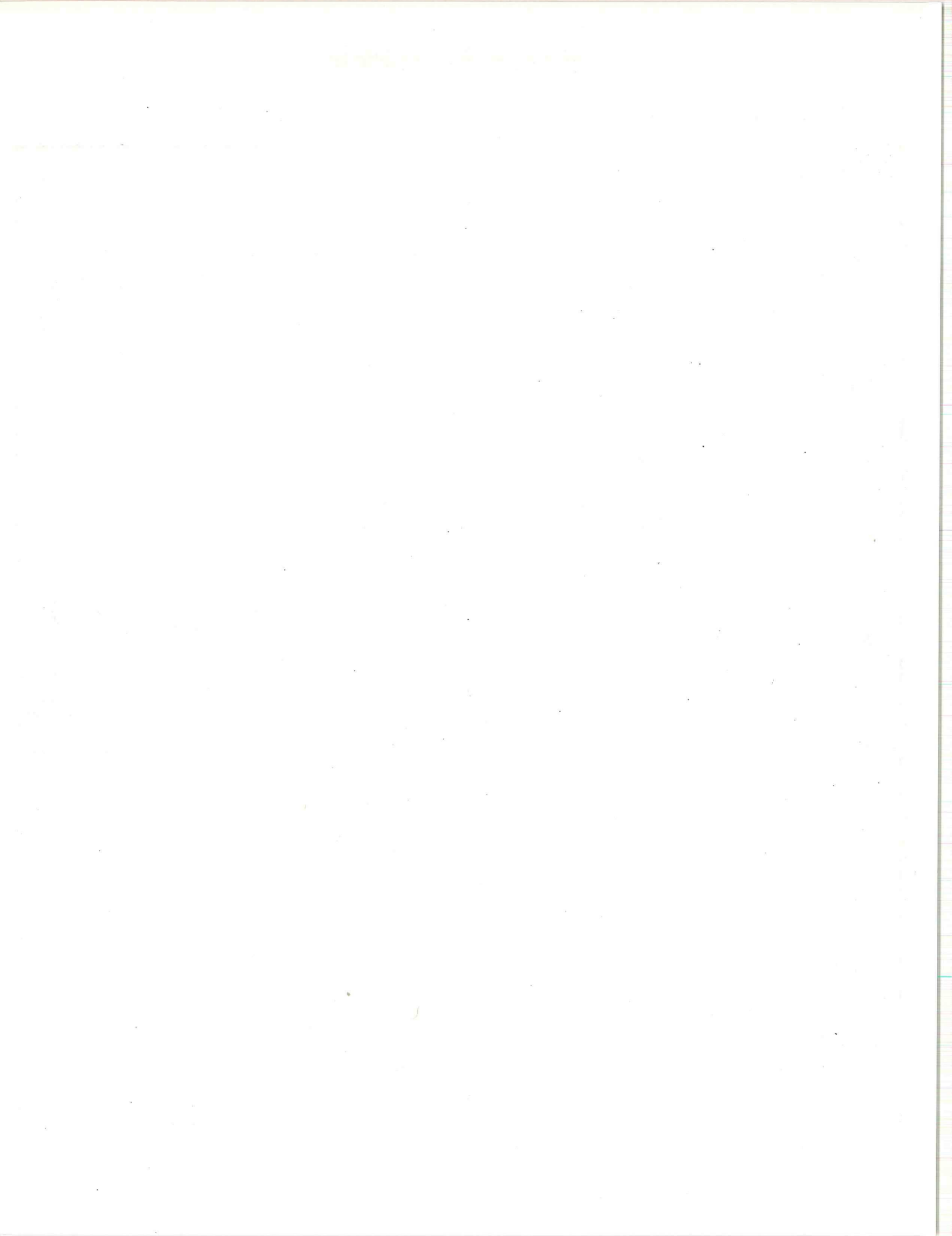

MATERIAL NAMES:

The standard used at Tek for naming parts is H6 (Cataloging Handbook). In some cases, the ASTM uses different names than H6. In such cases the H6 name will be used.

NAME	SHAPE
BAR	<p>(also Hex, Dodecagon, etc)</p> <p>≥.375 (≥9.525 mm)</p> <p>≥.375 (≥9.525 mm)</p> <p>≥.375 (≥9.525 mm)</p> <p>≥.375 (≥9.525 mm)</p> <p>≥.375 (≥9.525 mm)</p> <p>≥.375 (≥9.525 mm)</p> <p>.375 to 12" (9.525 to 304.8 mm)</p> <p>≥.094 (≥2.381 mm)</p>
ROD	DO NOT USE FOR METALS (Deleted from H6)
STRIP	<p>1.25 to 12" (31.75 mm to 304.8 mm)</p> <p>>.005 (>.132 mm) <.094 (<2.381 mm)</p>
*WIRE & *ROD	<p>(also Hex, Dodecagon, etc)</p> <p><.375 (≥9.525 mm)</p> <p><.375 (≥9.525 mm)</p> <p><.375 (≥9.525 mm)</p> <p><.375 (≥9.525 mm)</p> <p><.375 (≥9.525 mm)</p> <p><.375 (≥9.525 mm)</p> <p><.250 (<31.75 mm)</p> <p>>.005 (>.132 mm) <.094 (<2.381 mm)</p> <p>*Use WIRE for metal, and ROD for nonmetallic parts.</p>
SHEET	<p>>12" across narrowest flats. (>304.8 mm)</p> <p>>.005 (>.132 mm)</p>
FOIL & **FILM	<p>any width</p> <p>≤.005 (≤.132 mm)</p> <p>Use FOIL for metal, and FILM for nonmetallic parts.</p>

Some materials do not yet have specifications and may change without notice until the spec is finished. Also, some are exclusively used by one department and may be changed without notice by them.

CIRCUIT BOARD MATERIAL, EPOXY PREFORMS AND CERAMIC SUBSTRATES

SECTION 3

TABLE OF CONTENTS

	PAGE(S)
CIRCUIT BOARD MATERIAL	3-2 THRU 3-4
EPOXY PREFORMS	3-5
CERAMIC SUBSTRATES	3-6
UPDATES AND NOTES	3-7
CROSS REFERENCE INDEX	3-8 & 3-9

COST CODE (CC COLUMN)

CODE	~ VALUE with -	~ VALUE no suffix	~ VALUE with +
A	.2¢	.5¢	.75¢
B	1.25¢	1.5¢	2¢
C	2.5¢	3¢	3.75¢
D	4.25¢	5¢	6¢
E	7¢	8¢	10¢
F	13¢	15¢	18¢
G	22¢	25¢	35¢
H	40¢	50¢	60¢
I	65¢	75¢	\$1
J	\$1.25	\$1.50	\$2
K	\$2.50	\$3	\$3.75
L	\$4.25	\$5	\$6
M	\$7	\$8	\$10
N	\$13	\$15	\$18
O	\$22	\$25	\$35+

NOTE: Costs may vary from order to order
due to order quantities, vendor, etc.

CIRCUIT BOARD MATERIAL

EPOXY GLASS LAMINATE

THICKNESS	THICKNESS TOLERANCE ±	NOMINAL SHEET SIZE (INCHES)	CU	PART NUMBER	CC
.0025 Excluding foil	.001	12 x 20	.5/0	254-0588-00	sh K
.0033 Excluding foil	.0015	12 x 18	1/1	254-0571-02	sh K
.004 Excluding foil	.001	12 x 18	1/1	254-0570-02	sh K
.004 Excluding foil	.001	12 x 18	1/0	254-0570-03	sh K-
.004 Excluding foil	.001	12 x 20	1/1	254-0570-00	sh K+
.004 Excluding foil	.001	12 x 20	1/0	254-0570-01	sh K
.004 Excluding foil	.001	18 x 18	1/0	254-0570-04	sh L
.006 Excluding foil	.0015	12 x 18	1/0	254-0571-03	sh K-
.006 Excluding foil	.0015	12 x 20	.5/0	254-0629-00	sh K+
.006 Excluding foil	.0015	12 x 20	1/0	254-0571-01	sh K
.006 Excluding foil	.0015	12 x 20	.25	254-0571-00	sh K+
.008 Excluding foil	.001	24 x 30	.25/0	254-0658-00	sh N-
.008 Excluding foil	.0015	12 x 18	1/0	254-0572-06	sh K
.008 Excluding foil	.0015	12 x 18	1/1	254-0572-05	sh K
.008 Excluding foil	.0015	12 x 18	.5/.5	254-0572-07	sh K
.008 Excluding foil	.0015	12 x 20	1/0	254-0572-01	sh K
.008 Excluding foil	.0015	12 x 20	1/1	254-0572-00	sh K+
.008 Excluding foil	.0015	12 x 20	4/4	254-0584-00*	sh L
.008 Excluding foil	.0015	16 x 20	2/2	254-0635-00	sh M-
.008 Excluding foil	.0015	18 x 18	1/1	254-0572-03	sh L+
.008 Excluding foil	.0015	18 x 24	.5/.5	254-0572-08	sh
.008 Excluding foil	.0015	18 x 24	1/1	254-0572-02	sh L+
.008 Excluding foil	.0015	18 x 24	1/0	254-0572-04	sh L
.010 Excluding foil	.0015	12 x 20	1/1	254-0580-00	sh K+
.012 Excluding foil	.002	12 x 18	1/0	254-0568-05	sh K-
.012 Excluding foil	.002	12 x 18	1/1	254-0568-04	sh K
.012 Excluding foil	.002	12 x 18	.5/.5	254-0568-06	sh K
.012 Excluding foil	.002	12 x 20	1/0	254-0568-01	sh K+
.012 Excluding foil	.002	12 x 20	1/1	254-0568-00	sh L-
.012 Excluding foil	.002	18 x 18	1/1	254-0568-03	sh L+
.012 Excluding foil	.002	18 x 24	.5/.5	254-0568-07	sh
.012 Excluding foil	.002	18 x 24	1/1	254-0568-02	sh L+
.015 Excluding foil	.002	12 x 18	1/0	254-0573-06	sh K
.015 Excluding foil	.002	12 x 18	1/1	254-0573-05	sh K
.015 Excluding foil	.002	12 x 20	1/0	254-0573-01	sh K+
.015 Excluding foil	.002	12 x 20	1/1	254-0573-00	sh L-
.015 Excluding foil	.002	12 x 18	.5/.5	254-0573-07	sh
.015 Excluding foil	.002	18 x 18	1/1	254-0573-04	sh J
.015 Excluding foil	.002	18 x 24	.5/.5	254-0573-08	sh K
.015 Excluding foil	.002	18 x 24	1/1	254-0573-03	sh M-
.015 Excluding foil	.002	36 x 48	1/1	254-0639-00	sh O-
.021 Excluding foil	.003	12 x 18	2/1	254-0628-01	sh K+
.021 Excluding foil	.003	12 x 20	2/1	254-0628-00	sh L-
.022 Excluding foil	.002	12 x 20	1/1	254-0602-00	sh M-
.022 Excluding foil	.002	36 x 48	.5/.5	254-0602-01	sh O+
.002 Excluding foil	.002	36 x 48	1/1	254-0602-02	sh O+
.022 Excluding foil	.003	36 x 48	1/1	254-0661-00	sh O-
.023 Excluding foil	.003	12 x 18	1/1	254-0664-00	sh K+
.023 Excluding foil	.003	12 x 20	1/0	254-0577-01	sh L-
.023 Excluding foil	.003	12 x 20	1/1	254-0577-00	sh L
.023 Excluding foil	.003	36 x 48	1/0	254-0640-01	sh O-
.023 Excluding foil	.003	36 x 48	1/1	254-0640-00	sh O+
.025 Excluding foil	.002	12 x 20	1/1	254-0577-02	sh L-
.025 Excluding foil	.003	12 x 18	1/1	254-0577-07	sh L-
.025 Excluding foil	.003	12 x 18	1/1	254-0577-08	sh K+
.025 Excluding foil	.004	12 x 18	.5/.5	254-0577-09	sh K+
.025 Excluding foil	.003	12 x 20	.5/0	254-0590-00	sh L
.025 Excluding foil	.003	12 x 20	1/0	254-0577-04	sh L-
.025 Excluding foil	.003	12 x 20	1/1	254-0577-03	sh L
.025 Excluding foil	.003	16 x 20	1/1	254-0607-00	sh M
.025 Excluding foil	.003	18 x 18	1/1	254-0577-06	sh L+
.025 Excluding foil	.003	18 x 24	1/1	254-0577-05	sh M
.025 Excluding foil	.004	18 x 24	.5/.5	254-0577-10	sh M
.025 Excluding foil	.004	13 x 20	1/1	254-0559-00	sh M-
.028 Excluding foil	.003	18 x 18	1/1	254-0627-01	sh L
.029 Excluding foil	.003	12 x 20	1/1	254-0551-04	sh L
.029 Excluding foil	.004	12 x 18	1/1	254-0551-05	sh K
.029 Excluding foil	.004	13 x 20	1/1	254-0551-00	sh L-
.030 Excluding foil	.003	36 x 48	1/0	254-0638-00	sh O
.030 Excluding foil	.003	36 x 48	1/1	254-0627-00	sh O
.031 Including foil	.003	36 x 48	.5/0	254-0656-00	sh O+
.031	.004	12 x 18	.5/.5	254-0663-00	sh K+
.057 Excluding foil	.004	12 x 18	1/1	254-0593-02	sh K+
.057 Excluding foil	.004	13 x 20	1/1	254-0593-00	sh L
.059 Excluding foil	.005	12 x 18	1/1	254-0541-11	sh K+
.059 Including foil	.004	12 x 18	.25/.25	254-0660-00	sh L
.059 Including foil	.004	12 x 18	1/1	254-0593-03	sh L-

3

CIRCUIT BOARD MATERIAL (CONT)

EPOXY GLASS LAMINATE (CONT)

THICKNESS	THICKNESS TOLERANCE ±	NOMINAL SHEET SIZE (INCHES)	CU	PART NUMBER	CC
.059 Excluding foil	.004	12 x 20	.5/0	254-0594-00	sh L+
.060 Excluding foil	.003	12 x 18	1/1	254-0604-01	sh L
.060 Excluding foil	.004	9 x 12	1/1	254-0623-01	sh J+
.061 Excluding foil	.004	12 x 18	1/0	254-0541-08	sh K
.061 Excluding foil	.004	13 x 20	1/1	254-0564-00	sh K+
.062 Including foil	.004	12 x 18	.5/.5	254-0659-00	sh K
.062 Including foil	.004	12 x 18	1/1	254-0541-09	sh K+
.062 Including foil	.004	13 x 20	.5/.5	254-0659-01	sh L-
.062 Including foil	.004	13 x 20	1/1	254-0541-00	sh L
.062 Including foil	.004	36 x 48	1/1	254-0623-04	sh O
.063 Including foil	.004	12 x 18	1/1	254-0603-00	sh K+
.063 Including foil	.004	12 x 18	1/1	254-0603-01	sh L-
.063 Including foil	.004	13 x 20	1/1	254-0604-00	sh L
.063 Including foil	.004	18 x 18	1/1	254-0541-10	sh L
.063 Including foil	.004	36 x 48	1/1	254-0541-06	sh O+
.091 Excluding foil	.009	13 x 20	1/1	254-0548-00	sh M
.123 Excluding foil	.012	13 x 20	1/1	254-0578-00	sh M+
.123 Excluding foil	.012	36 x 48	1/1	254-0634-00	sh O+

VECTOR BOARDS CANNOT BE ORDERED FROM REGULAR STOCK. THEY ARE MADE BY REQUEST FOR THE ENGINEERING STOCK AREAS AND CAN ONLY BE OBTAINED THROUGH ENGINEERING STOCK.

TEFLON GLASS LAMINATE

THICKNESS	THICKNESS TOLERANCE ±	NOMINAL SHEET SIZE (INCHES)	CU	PART NUMBER	CC
.008 Excluding foil	.001	23 x 35	1/1	254-0592-00	sh O+
.010 Excluding foil	.007	10 x 16	.5/.5	254-0648-00	sh O+
.021 Excluding foil	.0015	12 x 18	.5/.5	254-0657-00	sh O+
.028 Excluding foil	.0015	12 x 18	.5/.5	254-0655-00	sh O+
.028 Excluding foil	.002	12 x 20	1/1	254-0599-00	sh O+
.035 Excluding foil	.001	10 x 16	.5/0	254-0651-00*	sh O+
.035 Excluding foil	.001	10 x 16	.5/.5	254-0652-00*	sh O+
.062 Excluding foil	.002	10 x 16	.5/0	254-0650-00*	sh O+
.093 Excluding foil	.005	6.5 x 10	1/1	254-0576-00	sh N

POLYIMIDE LAMINATE

THICKNESS	THICKNESS TOLERANCE ±	NOMINAL SHEET SIZE (INCHES)	CU	PART NUMBER	CC
.002 Excluding foil	+ .001 - .000	24 x 36	2/0	254-0598-01*	sq ft K+
.002 Excluding foil	- .000 ± .001 + .000	21 x 36	1/0	254-0598-00*	sh O+
.002 Excluding foil	+ .001 - .000	12 x 20	1/1	254-0643-00	sq ft L

POLYIMIDE GLASS LAMINATE

THICKNESS	THICKNESS TOLERANCE ±	NOMINAL SHEET SIZE (INCHES)	CU	PART NUMBER	CC
.005 Excluding foil	± .0005	12 x 18	1/0	254-0665-00	sh N
.005 Excluding foil	± .0005	12 x 18	2/0	254-0666-00	sh N
.062 Excluding foil	- .000 ± .005	36 x 36	1/1	254-0597-00*	sh O

CROSSLINKED POLYSTYRENE LAMINATE

THICKNESS	THICKNESS TOLERANCE ±	NOMINAL SHEET SIZE (INCHES)	CU	PART NUMBER	CC
.062	.004	6.5 x 10	1/1	254-0581-00*	sh O
.250	.009	6.5 x 10	1/1	254-0582-00*	sh N

UNCURED EPOXY (PRE-PREG)

THICKNESS	THICKNESS TOLERANCE ±	NOMINAL SHEET SIZE (INCHES)	PART NUMBER	CC
.0025	.001	12 x 18	254-0618-05	sh I-
.0025		12 x 20	254-0618-00	sh I
.0025		18 x 24	254-0618-09	sh J-
.0025		18 x 18	254-0618-11	sh J-
.003		12 x 20	254-0618-04	sh K-
.004		12 x 18	254-0618-06	sh I
.004		16 x 20	254-0618-07	sh J
.004		18 x 18	254-0618-12	sh I+
.004		18 x 24	254-0618-10	sh J
.004		7 x 9	254-0618-13	sh G
.0045		12 x 20	254-0618-01	sh I+

* MATERIAL DOES NOT HAVE UL RECOGNITION

** UL RATING NOTE: EXCEPT AS NOTED, MATERIAL HAS UL V-0 RATING. AFTER PROCESSING BY TEKTRONIX, INC., FLAME RATING OF MATERIAL WILL BE UL94 V-1 OR BETTER. REFER TO TEK STANDARD 062-1778-00 FOR DESIGN AND FABRICATION REQUIREMENTS OF FLAMMABILITY CLASSIFIED CIRCUIT BOARDS. FOR MORE INFORMATION, CONTACT PRODUCT SAFETY ENGINEERING, EXT. 1815.

3

CIRCUIT BOARD MATERIAL (CONT)

POLYSULPHONE LAMINATE

THICKNESS	THICKNESS TOLERANCE ±	NOMINAL SHEET SIZE (INCHES)	CU	PART NUMBER	CC
.062	.002	24 x 48	0/0	255-0575-00*	sh 0+
.062	.002	24 x 48	0/0	255-0640-00	sh 0+

EPOXY GLASS LAMINATE (UNCLAD)

THICKNESS	THICKNESS TOLERANCE ±	NOMINAL SHEET SIZE (INCHES)	PART NUMBER	CC
.031	.004	13 x 20	254-0546-00	sh L-
.062	.0075	13 x 20	254-0566-00	sh M-
.062	+1.000 +.0075	36 x 48	006-1677-00	sh 0
.093	.009	13 x 20	254-0556-00	sq in A
.312		13 x 20	006-0438-00	sh I

PLASTIC FILM (SHEET)

THICKNESS	REMARKS	SHEET SIZE	PART NUMBER	CC
.001	Mylar, adhesive one side	10 x 12	254-0667-00	sh
.001	"Poxy" 1001	21.5" x 29.25	255-0516-02	sh L+
.001	"Polyfilm" 1001	12" x 20	255-0516-01	sh J+
.001	"Poxy" 1001 (adhesive bond)	40" wide	255-0516-00*	r1 0+
.001	.001 Kapton (1 side), .001 adhesive (1 side)	12" wide	254-0644-00	sq ft L
.0015	Fluorocarb copolymer bonding	12" wide	254-0600-00*	sq ft I+
.002	Polyvinyl Fluoride	12" wide	255-0533-00*	sq ft E+
.002	Polyvinyl Fluoride	24" wide	255-0533-01	sq ft F
.002	Polyvinyl Fluoride	24 x 30	255-0533-03	sh J
.002	Polyvinyl Fluoride	12 x 20	255-0533-02	sh I
.003	.001 Kapton (1 side), .002 adhesive (1 side)	12" wide	254-0644-01	sq ft K
.005	Polyester, Electrical Grade	20" x 50"	254-0601-00*	sh I
.006	Polyester (adhesive coating)	12.75" x 200 ft	255-0344-00	ft G-
.020	Polycarbonate	24" x 48"	255-0295-00*	sq ft H-

* MATERIAL DOES NOT HAVE UL RECOGNITION

** UL RATING NOTE: EXCEPT AS NOTED, MATERIAL HAS UL V-0 RATING. AFTER PROCESSING BY TEKTRONIX, INC., FLAME RATING OF MATERIAL WILL BE UL94 V-1 OR BETTER. REFER TO TEK STANDARD 062-1778-00 FOR DESIGN AND FABRICATION REQUIREMENTS OF FLAMMABILITY CLASSED CIRCUIT BOARDS. FOR MORE INFORMATION, CONTACT PRODUCT SAFETY ENGINEERING, EXT. 1815.

EPOXY PREFORMS

DIMENSIONS		ID	OD	MATERIAL THICKNESS ABLE FILM 550	PART NUMBER	CC
LENGTH	WIDTH					
		.100	.170	.004	255-0697-00*	
		.230	.325		255-0541-01	ea E
.050	.050			.006	255-0687-00	ea C+
.180	.180	.100		.006	255-0588-00	ea C+
.275	.250			.004 ± .005	255-0673-00	ea C+
.300	.300			.006	255-0712-00	ea E-
.320	.320	.250 sq		.005 ± .001	255-0620-00	ea E+
.400	.400			.005	255-0667-00	ea E
.440	.272			.004	255-0708-00	ea E-
.440	.272			.006	255-0672-00	ea E-
.497	.497			.004	255-0671-00	ea E
.510	.510	.410 sq		.005 ± .001	255-0650-00	ea F-
.560	.224			.005 (550T)	255-0699-00	ea E+
.700	.700			.006	255-0707-00	ea F-
.705	.465	.625 x .385		.005 ± .001	255-0628-00	ea F-
.720	.520	.580 x .380		.005 ± .001	255-0649-00	ea E+
.775	.865			.005	255-0669-00	ea G
.855	.208			.003 (550T)	255-0668-00	ea G+
.900	.500			.006	255-0706-00	ea F-

3

COST CODE (CC COLUMN)

CODE	A	B	C	D	E	F	G	H	I	J	K	L	M	N	O
≈ VALUE with +	.75¢	2¢	3.75¢	6¢	10¢	18¢	35¢	60¢	\$1	\$2	\$3.75	\$6	\$10	\$18	\$35+
≈ VALUE no suffix	.5¢	1.5¢	3¢	5¢	8¢	15¢	25¢	50¢	75¢	\$1.50	\$3	\$5	\$8	\$15	\$25
≈ VALUE with -	.2¢	1.25¢	2.5¢	4.25¢	7¢	13¢	22¢	40¢	65¢	\$1.25	\$2.50	\$4.25	\$7	\$13	\$22

NOTE: Costs may vary from order to order due to order quantities, vendor, etc.

* ABLE FILM 556

CERAMIC SUBSTRATES

LENGTH	WIDTH	THICKNESS	PART NUMBER	CC	SOURCE	STANDARD BASE MATERIAL	MATERIAL FAMILY	MAXIMUM THICKNESS OPTION *	REMARKS
.325	.325	.030	204-0585-00	ea	Tek-Made	96% alumina	A	.100	
.365	.365	.035	204-0499-00	ea	Tek-Made	96% alumina	A	.100	
.520	.520	.025	342-0082-00	ea	Tek-Made	96% alumina	A	.125	
.700	.640	.030	204-0611-00	ea	Tek-Made	96% alumina	A	.150	
.750	.600	.040	342-0582-01	ea	Tek-Made	96% alumina	A	.150	
.750	.600	.100	342-0582-00	ea	Tek-Made	96% alumina	A	.150	
.850	.300	.062	204-0488-02	ea	Tek-Made	96% alumina	A	.100	
.850	.300	.025	204-0488-01	ea	Tek-Made	96% alumina	A	.100	
.850	.300	.040	204-0488-00	ea	Tek-Made	96% alumina	A	.100	
1.000	.400	.040	307-0211-02	ea	Tek-Made	96% alumina	A	.125	
1.000	.500	.025	204-0511-00	ea H	Tek-Made				
1.000	1.000	.050	204-0466-00	ea K-	Purchased				
1.000	1.000	.040	204-0604-00	ea	Tek-Made	96% alumina	A	.100	
1.325	1.000	.040	204-0651-00	ea	Tek-Made	96% alumina	A	.125	2 holes at edge
1.480	1.020	.060	204-0603-00	ea	Tek-Made	96% alumina	A	.150	4 holes near edges
1.500	.500	.030	204-0519-00	ea D+	Purchased				
1.500	1.000	.025	204-0586-00	ea D+	Purchased				
1.550	.720	.040	204-0462-02	ea	Tek-Made	96% alumina	A	.100	Cut from 204-0462-01
1.880	.900	.045	342-0449-00	ea	Tek-Made	85% alumina	A	.150	.156 holes in ends
1.980	1.980	.060	342-0461-00	ea	Tek-Made	96% alumina	A	.125	.225 hole in center
2.000	.500	.025	204-0512-00	ea G+	Tek-Made				
2.000	1.000	.097	204-0503-01	ea	Tek-Made	96% alumina	A	.150	8 holes
2.000	1.000	.160	204-0486-02	ea	Tek-Made	96% alumina	A	.160	
2.000	1.000	.040	204-0486-00	ea	Tek-Made	96% alumina	A	.160	
2.000	1.500	.025	204-0537-00	ea	Tek-Made	B394 forsterite	B	.125	Ground flat
2.320	.630	.040	204-0541-00	ea	Tek-Made	96% alumina	A	.100	
2.320	.630	.040	204-0462-01	ea	Tek-Made	96% alumina	A	.100	
2.600	1.525	.060	204-0460-00	ea	Tek-Made	96% alumina	A	.100	11 holes .062 on edge
2.900	.975	.040	204-0778-00	ea	Tek-Made				
3.000	3.000	.025	204-0817-00	ea O+	Purchased				Quartz
3.000	3.000	.025	204-0818-00	ea O+	Purchased				
3.000	3.000	.032	204-0702-00	ea J+	Purchased				
3.000	3.000	.040	204-0710-00	ea N	Purchased				
3.000	3.000	.090	204-0861-00	ea N+	Purchased				

ADDITIONAL SUBSTRATES CAN BE PRODUCED WITHOUT TOOLING CHANGES UNDER THE FOLLOWING CONDITIONS:

1. USE SAME MATERIAL FAMILY AS LISTED IN STANDARD BASE MATERIAL TABLE BELOW.
- * 2. DO NOT EXCEED MAXIMUM THICKNESS LISTED.
3. LENGTH AND WIDTH REMAIN SAME AS EXISTING PART NUMBER.
4. NEW PART NUMBERS NEED TO BE ASSIGNED.
5. OPTIONS PERTAIN ONLY TO TEK-MADE PARTS.

PURCHASED RAW MATERIALS	DESCRIPTION	FAMILY
252-0115-00	White, 85% alumina	A
252-0115-01	Pink, 85% alumina	A
252-0115-02	Green, 85% alumina	A
252-0115-03	Black, 85% alumina	A
252-0168-00	White, 96% alumina	A
252-0121-02	B394 forsterite	B
252-0121-03	B391 forsterite	B
252-0121-04	B398 forsterite	B
252-0726-00	X-Ray attenuating forsterite	B
252-0109-00	Alumina porcelain	B
252-0108-00	Steatite porcelain	B

IF YOU DO NOT FIND WHAT YOU NEED, CALL HCM MATERIALS AND COMPONENTS ENGINEERING:

JOHN DILAZZARO EXT. 3972-B
BOB ROGERS EXT. 3971-B
MIKE EHLERT EXT. 3975-B

UPDATES AND NOTES

COST CODE (CC COLUMN)

CODE	~ VALUE with -	~ VALUE no suffix	~ VALUE with +
A	.2¢	.5¢	.75¢
B	1.25¢	1.5¢	2¢
C	2.5¢	3¢	3.75¢
D	4.25¢	5¢	6¢
E	7¢	8¢	10¢
F	13¢	15¢	18¢
G	22¢	25¢	35¢
H	40¢	50¢	60¢
I	65¢	75¢	\$1
J	\$1.25	\$1.50	\$2
K	\$2.50	\$3	\$3.75
L	\$4.25	\$5	\$6
M	\$7	\$8	\$10
N	\$13	\$15	\$18
O	\$22	\$25	\$35+

NOTE: Costs may vary from order to order
due to order quantities, vendor, etc.

CROSS REFERENCE INDEX

CIRCUIT BOARD MATERIAL, EPOXY PREFORMS AND CERAMIC SUBSTRATES

3

PART NUMBER	DESCRIPTION	PAGE NO.	STATUS
006-0438-00	Epoxy Glass Laminate (Unclad)	3-4	CR
006-1677-00	Epoxy Glass Laminate (Unclad)	3-4	CR
204-0460-00	Ceramic Substrate	3-6	CR
204-0462-01	Ceramic Substrate	3-6	CR
204-0462-02	Ceramic Substrate	3-6	CS
204-0466-00	Ceramic Substrate	3-6	CR
204-0486-00	Ceramic Substrate	3-6	CR
204-0486-02	Ceramic Substrate	3-6	CR
204-0488-00	Ceramic Substrate	3-6	CR
204-0488-01	Ceramic Substrate	3-6	CR
204-0488-02	Ceramic Substrate	3-6	CR
204-0499-00	Ceramic Substrate	3-6	CR
204-0503-01	Ceramic Substrate	3-6	CR
204-0511-00	Ceramic Substrate	3-6	CR
204-0512-00	Ceramic Substrate	3-6	CR
204-0519-00	Ceramic Substrate	3-6	CR
204-0537-00	Ceramic Substrate	3-6	CS
204-0541-00	Ceramic Substrate	3-6	CR
204-0585-00	Ceramic Substrate	3-6	CR
204-0586-00	Ceramic Substrate	3-6	CR
204-0603-00	Ceramic Substrate	3-6	CR
204-0604-00	Ceramic Substrate	3-6	CR
204-0611-00	Ceramic Substrate	3-6	CR
204-0651-00	Ceramic Substrate	3-6	CS
204-0688-00	Ceramic Substrate		NP
204-0702-00	Ceramic Substrate	3-6	CR
204-0710-00	Ceramic Substrate	3-6	CR
204-0778-00	Ceramic Substrate	3-6	CR
204-0817-00	Ceramic Substrate	3-6	CR
204-0818-00	Ceramic Substrate	3-6	CR
204-0823-00	Ceramic Substrate		DL
204-0861-00	Ceramic Substrate	3-6	CR
252-0108-00	Ceramic Substrate Materials	3-6	CR
252-0109-00	Ceramic Substrate Materials	3-6	CR
252-0115-00	Ceramic Substrate Materials	3-6	CR
252-0115-01	Ceramic Substrate Materials	3-6	CR
252-0115-02	Ceramic Substrate Materials	3-6	CR
252-0115-03	Ceramic Substrate Materials	3-6	CR
252-0121-02	Ceramic Substrate Materials	3-6	CR
252-0121-03	Ceramic Substrate Materials	3-6	CR
252-0121-04	Ceramic Substrate Materials	3-6	CR
252-0168-00	Ceramic Substrate Materials	3-6	CR
252-0726-00	Ceramic Substrate Materials	3-6	MP
254-0541-00	Epoxy Glass Laminate	3-3	CR
254-0541-05	Epoxy Glass Laminate		NP
254-0541-06	Epoxy Glass Laminate	3-3	CR
254-0541-08	Epoxy Glass Laminate	3-3	CR
254-0541-09	Epoxy Glass Laminate	3-3	CR
254-0541-10	Epoxy Glass Laminate	3-3	PP
254-0541-11	Epoxy Glass Laminate	3-2	PP
254-0546-00	Epoxy Glass Laminate (Unclad)	3-4	CR
254-0548-00	Epoxy Glass Laminate	3-3	CR
254-0551-00	Epoxy Glass Laminate	3-2	CR
254-0551-04	Epoxy Glass Laminate	3-2	CR
254-0551-05	Epoxy Glass Laminate	3-2	CR
254-0556-00	Epoxy Glass Laminate (Unclad)	3-4	CS
254-0559-00	Epoxy Glass Laminate	3-2	CR
254-0563-01	Uncured Epoxy (Pre-Preg)		NP
254-0563-03	Uncured Epoxy (Pre-Preg)		DL
254-0564-00	Epoxy Glass Laminate	3-3	CR
254-0566-00	Epoxy Glass Laminate (Unclad)	3-4	CR
254-0567-01	Polyphenylene Oxide Laminate		LS
254-0568-00	Epoxy Glass Laminate	3-2	CR
254-0568-01	Epoxy Glass Laminate	3-2	CR
254-0568-02	Epoxy Glass Laminate	3-2	CR
254-0568-03	Epoxy Glass Laminate	3-2	CR
254-0568-04	Epoxy Glass Laminate	3-2	CR
254-0568-05	Epoxy Glass Laminate	3-2	CR
254-0568-06	Epoxy Glass Laminate	3-2	CR
254-0568-07	Epoxy Glass Laminate	3-2	PP
254-0569-00	Polyphenylene Oxide Laminate		LR
254-0570-00	Epoxy Glass Laminate	3-2	CR
254-0570-01	Epoxy Glass Laminate	3-2	CR
254-0570-02	Epoxy Glass Laminate	3-2	EN
254-0570-03	Epoxy Glass Laminate	3-2	PP

PART NUMBER	DESCRIPTION	PAGE NO.	STATUS
254-0570-04	Epoxy Glass Laminate	3-2	CR
254-0571-00	Epoxy Glass Laminate	3-2	OT
254-0571-01	Epoxy Glass Laminate	3-2	CR
254-0571-02	Epoxy Glass Laminate	3-2	CR
254-0571-03	Epoxy Glass Laminate	3-2	CR
254-0572-00	Epoxy Glass Laminate	3-2	CR
254-0572-01	Epoxy Glass Laminate	3-2	CR
254-0572-02	Epoxy Glass Laminate	3-2	PP
254-0572-03	Epoxy Glass Laminate	3-2	CR
254-0572-04	Epoxy Glass Laminate	3-2	PP
254-0572-05	Epoxy Glass Laminate	3-2	CR
254-0572-06	Epoxy Glass Laminate	3-2	CR
254-0572-07	Epoxy Glass Laminate	3-2	CR
254-0572-08	Epoxy Glass Laminate	3-2	PP
254-0573-00	Epoxy Glass Laminate	3-2	CR
254-0573-01	Epoxy Glass Laminate	3-2	CR
254-0573-02	Epoxy Glass Laminate		DL
254-0573-03	Epoxy Glass Laminate	3-2	CR
254-0573-04	Epoxy Glass Laminate	3-2	CR
254-0573-05	Epoxy Glass Laminate	3-2	CR
254-0573-06	Epoxy Glass Laminate	3-2	CR
254-0573-07	Epoxy Glass Laminate	3-2	CR
254-0573-08	Epoxy Glass Laminate	3-2	PP
254-0576-00	Teflon Glass Laminate	3-3	CR
254-0577-00	Epoxy Glass Laminate	3-2	CR
254-0577-01	Epoxy Glass Laminate	3-2	CR
254-0577-02	Epoxy Glass Laminate	3-2	CR
254-0577-03	Epoxy Glass Laminate	3-2	CR
254-0577-04	Epoxy Glass Laminate	3-2	CR
254-0577-05	Epoxy Glass Laminate	3-2	PP
254-0577-06	Epoxy Glass Laminate	3-2	CR
254-0577-07	Epoxy Glass Laminate	3-2	CR
254-0577-08	Epoxy Glass Laminate	3-2	CR
254-0577-09	Epoxy Glass Laminate	3-2	CR
254-0577-10	Epoxy Glass Laminate	3-2	PP
254-0578-00	Epoxy Glass Laminate	3-3	CR
254-0580-00	Epoxy Glass Laminate	3-2	CR
254-0581-00	Crosslinked Polystyrene Laminate	3-3	CR
254-0582-00	Crosslinked Polystyrene Laminate	3-3	CS
254-0584-00	Epoxy Glass Laminate	3-2	CR
254-0588-00	Epoxy Glass Laminate	3-2	CS
254-0590-00	Epoxy Glass Laminate	3-2	CR
254-0592-00	Teflon Glass Laminate	3-3	CR
254-0593-00	Epoxy Glass Laminate	3-2	CR
254-0593-02	Epoxy Glass Laminate	3-2	CR
254-0593-03	Epoxy Glass Laminate	3-2	CR
254-0594-00	Epoxy Glass Laminate	3-3	CS
254-0597-00	Polyimide Glass Laminate	3-3	OB
254-0598-00	Polyimide, Laminate	3-3	CR
254-0598-01	Polyimide, Laminate	3-3	CR
254-0599-00	Teflon Glass Laminate	3-3	CR
254-0600-00	Plastic Film (Sheet)	3-4	CR
254-0601-00	Plastic Film (Sheet)	3-4	CR
254-0602-00	Epoxy Glass Laminate	3-2	CR
254-0602-01	Epoxy Glass Laminate	3-2	CR
254-0602-02	Epoxy Glass Laminate	3-2	CR
254-0603-00	Epoxy Glass Laminate	3-3	CR
254-0603-01	Epoxy Glass Laminate	3-3	CR
254-0604-00	Epoxy Glass Laminate	3-3	CR
254-0604-01	Epoxy Glass Laminate	3-3	PP
254-0605-00	Epoxy Glass Laminate		DL
254-0606-00	Epoxy Glass Laminate		DL
254-0607-00	Epoxy Glass Laminate	3-2	CR
254-0608-00	Epoxy Glass Laminate		DL
254-0609-00	Epoxy Glass Laminate		DL
254-0611-00	Epoxy Glass Laminate		NP
254-0611-02	Epoxy Glass Laminate		DL
254-0613-00	Epoxy Glass Laminate		NP
254-0613-01	Epoxy Glass Laminate		DL
254-0614-00	Epoxy Glass Laminate		NP
254-0615-03	Epoxy Glass Laminate		NP
254-0618-00	Uncured Epoxy (Pre-Preg)	3-3	CR
254-0618-01	Uncured Epoxy (Pre-Preg)	3-3	CR
254-0618-04	Uncured Epoxy (Pre-Preg)	3-3	CS
254-0618-05	Uncured Epoxy (Pre-Preg)	3-3	CR
254-0618-06	Uncured Epoxy (Pre-Preg)	3-3	CR

CROSS REFERENCE INDEX (CONT)

CIRCUIT BOARD MATERIAL, EPOXY PREFORMS AND CERAMIC SUBSTRATES

3

PART NUMBER	DESCRIPTION	PAGE NO.	STATUS ^{§§}
254-0618-07	Uncured Epoxy (Pre-Preg)	3-3	CR
254-0618-08	Uncured Epoxy (Pre-Preg)		DL
254-0618-09	Uncured Epoxy (Pre-Preg)	3-3	PP
254-0618-10	Uncured Epoxy (Pre-Preg)	3-3	PP
254-0618-11	Uncured Epoxy (Pre-Preg)	3-3	CR
254-0618-12	Uncured Epoxy (Pre-Preg)	3-3	CR
254-0618-13	Uncured Epoxy (Pre-Preg)	3-3	CR
254-0621-01	Epoxy Glass Laminate (Unclad)		DL
254-0623-00	Epoxy Glass Laminate		NP
254-0623-01	Epoxy Glass Laminate	3-3	CR
254-0623-03	Epoxy Glass Laminate		NP
254-0623-04	Epoxy Glass Laminate	3-3	CS
254-0624-00	Epoxy Glass Laminate		DL
254-0624-01	Epoxy Glass Laminate		DL
254-0625-00	Epoxy Glass Laminate		DL
254-0627-00	Epoxy Glass Laminate	3-2	CR
254-0627-01	Epoxy Glass Laminate	3-2	PP
254-0628-00	Epoxy Glass Laminate	3-2	CR
254-0628-01	Epoxy Glass Laminate	3-2	CR
254-0629-00	Epoxy Glass Laminate	3-2	CR
254-0630-00	Epoxy Glass Laminate		DL
254-0634-00	Epoxy Glass Laminate	3-3	CR
254-0635-00	Epoxy Glass Laminate	3-2	CR
254-0636-00	Teflon Glass Laminate		DL
254-0637-00	Epoxy Glass Laminate		NP
254-0638-00	Epoxy Glass Laminate	3-2	CR
254-0639-00	Epoxy Glass Laminate	3-2	CR
254-0640-00	Epoxy Glass Laminate	3-2	CR
254-0640-01	Epoxy Glass Laminate	3-2	CS
254-0641-00	Epoxy Glass Laminate		OB
254-0642-00	Teflon Glass Laminate		NP
254-0642-01	Teflon Glass Laminate		DL
254-0643-00	Polimide, Laminate	3-3	OT
254-0644-00	Plastic Film (Sheet)	3-4	CR
254-0644-01	Plastic Film (Sheet)	3-4	CR
254-0648-00	Teflon Glass Laminate	3-3	CR
254-0649-00	Teflon Glass Laminate		DL
254-0650-00	Teflon Glass Laminate	3-3	CR
254-0651-00	Teflon Glass Laminate	3-3	CR
254-0652-00	Teflon Glass Laminate	3-3	CR
254-0655-00	Teflon Glass Laminate	3-3	CR
254-0656-00	Epoxy Glass Laminate	3-2	CR
254-0657-00	Teflon Glass Laminate	3-3	CR
254-0658-00	Epoxy Glass Laminate	3-2	CR
254-0659-00	Epoxy Glass Laminate	3-3	CR
254-0659-01	Epoxy Glass Laminate	3-3	CR
254-0660-00	Epoxy Glass Laminate	3-2	PP
254-0661-00	Epoxy Glass Laminate	3-2	CR
254-0662-00	Epoxy Glass Laminate (Unclad)		NP
254-0663-00	Epoxy Glass Laminate	3-2	CR
254-0664-00	Epoxy Glass Laminate	3-2	PP
254-0665-00	Polyimide Glass Laminate	3-3	PP
254-0666-00	Polyimide Glass Laminate	3-3	PP
254-0667-00	Plastic Film (Sheet)	3-4	CR
255-0295-00	Plastic Film (Sheet)	3-4	CR
255-0344-00	Plastic Film (Sheet)	3-4	CR
255-0516-00	Plastic Film (Sheet)	3-4	CR
255-0516-01	Plastic Film (Sheet)	3-4	CR
255-0516-02	Plastic Film (Sheet)	3-4	MP
255-0533-00	Plastic Film (Sheet)	3-4	CR
255-0533-01	Film, Miscellaneous	3-4	CR
255-0533-02	Film, Miscellaneous	3-4	CR
255-0533-03	Plastic Film (Sheet)	3-4	MP
255-0541-01	Epoxy Preforms	3-5	CR
255-0575-00	Polysulfone Laminate	3-4	CR
255-0588-00	Epoxy Preforms	3-5	CR
255-0609-00	Epoxy Preforms		NP
255-0611-00	Epoxy Preforms		DL
255-0620-00	Epoxy Preforms	3-5	CR
255-0628-00	Epoxy Preforms	3-5	CR
255-0640-00	Polysulfone Laminate	3-4	CR
255-0649-00	Epoxy Preforms	3-5	CR
255-0650-00	Epoxy Preforms	3-5	CR
255-0667-00	Epoxy Preforms	3-5	CR
255-0668-00	Epoxy Preforms	3-5	CR

PART NUMBER	DESCRIPTION	PAGE NO.	STATUS ^{§§}
255-0669-00	Epoxy Preforms	3-5	CR
255-0671-00	Epoxy Preforms	3-5	CR
255-0672-00	Epoxy Preforms	3-5	CR
255-0673-00	Epoxy Preforms	3-5	CR
255-0687-00	Epoxy Preforms	3-5	CR
255-0697-00	Epoxy Preforms	3-5	PP
255-0699-00	Epoxy Preforms	3-5	CR
255-0706-00	Epoxy Preforms	3-5	CR
255-0707-00	Epoxy Preforms	3-5	CR
255-0708-00	Epoxy Preforms	3-5	CR
255-0712-00	Epoxy Preforms	3-5	CR
307-0210-00	Ceramic Substrate		NP
307-0211-02	Ceramic Substrate	3-6	CR
342-0082-00	Ceramic Substrate	3-6	CR
342-0449-00	Ceramic Substrate	3-6	CR
342-0461-00	Ceramic Substrate	3-6	CR
342-0582-00	Ceramic Substrate	3-6	CR
342-0582-01	Ceramic Substrate	3-6	PP

§§ STATUS CODES

CR	Current Production
EN	Engineering
PP	Pre-Production
CS	Customer Service
NP	Non-Production
DL	Deleted
OB	Obsolete Instrument
CM	Custom Mod Instrument
DS	Digital Systems
OT	Obsolescent Instrument
MP	Modified Part
LR	Last Supply Current
LS	Last Supply Customer Service
VN	Vendor
TC	Tequipment Current Production
IN	International
SC	Sony/Tek Current Production

THE STATUS IN THIS CATALOG WAS CORRECT AT THE TIME IT WAS PUBLISHED, BUT IT IS SUBJECT TO CHANGE.

§ TO USE A PART WITH THIS STATUS ON A NEW INSTRUMENT REQUIRES THAT A NEW PURCHASED PART INITIATION FORM (PIF) BE INITIATED.

(A GLOSSARY OF TERMS FOR THESE STATUS CODES CAN BE FOUND ON PAGE 0-10).

GROUP RESEARCH INDEX (CONT.)

GROUP	RESEARCHER	RESEARCH TITLE	RESEARCH YEAR
1
2
3
4
5
6
7
8
9
10
11
12
13
14
15
16
17
18
19
20
21
22
23
24
25
26
27
28
29
30
31
32
33
34
35
36
37
38
39
40
41
42
43
44
45
46
47
48
49
50
51
52
53
54
55
56
57
58
59
60
61
62
63
64
65
66
67
68
69
70
71
72
73
74
75
76
77
78
79
80
81
82
83
84
85
86
87
88
89
90
91
92
93
94
95
96
97
98
99
100

THE UNIVERSITY OF CHICAGO
 LIBRARY
 540 EAST 57TH STREET
 CHICAGO, ILL. 60637
 TEL: 773-936-3700
 FAX: 773-936-3701
 WWW: WWW.CHICAGO.LIBRARY.EDU

GROUP	RESEARCHER	RESEARCH TITLE	RESEARCH YEAR
101
102
103
104
105
106
107
108
109
110
111
112
113
114
115
116
117
118
119
120
121
122
123
124
125
126
127
128
129
130
131
132
133
134
135
136
137
138
139
140
141
142
143
144
145
146
147
148
149
150
151
152
153
154
155
156
157
158
159
160
161
162
163
164
165
166
167
168
169
170
171
172
173
174
175
176
177
178
179
180
181
182
183
184
185
186
187
188
189
190
191
192
193
194
195
196
197
198
199
200

CHEMICAL ELEMENTS AND SYMBOLS

FOR REFERENCE, FOLLOWING IS AN ALPHABETICAL LISTING OF CHEMICAL ELEMENTS AND THEIR RESPECTIVE SYMBOLS:

Actinium	Ac	Manganese	Mn
Aluminum	Al	Mendelevium	Md
Americium	Am	Mercury, hydrargyrum	Hg
Antimony, stibium	Sb	Molybdenum	Mo
Argon	A	Neodymium	Nd
Arsenic	As	Neon	Ne
Astatine	At	Neptunium	Np
Barium	Ba	Nickel	Ni
Berkelium	Bk	Niton, see Radon	
Beryllium, glucinum	Be	Nitrogen	N
Bismuth	Bi	Nobelium	No
Boron	B	Osmium	Os
Bromine	Br	Oxygen	O
Cadmium	Cd	Palladium	Pd
Calcium	Ca	Phosphorus	P
Californium	Cf	Platinum	Pt
Carbon	C	Plutonium	Pu
Cassiopeium, see Lutetium		Polonium	Po
Cerium	Ce	Potassium, kalium	K
Cesium	Cs	Pradeodymium	Pr
Chlorine	Cl	Promethium	Pm
Chromium	Cr	Protactinium	Pa
Cobalt	Co	Radium	Ra
Columbium, Niobium	Cb	Radon, niton	Rn
Copper	Cu	Rhenium	Re
Curium	Cm	Rhodium	Rh
Dysprosium	Dy	Rubidium	Rb
Einsteinium	Es	Ruthenium	Ru
Erbium	Er	Samarium	Sm, Sa
Europium	Eu	Scandium	Sc
Fermium	Fm	Selenium	Se
Fluorine	F	Silicon	Si
Francium	Fr	Silver, argentum	Ag
Gadolinium	Gd	Sodium, natrium	Na
Gallium	Ga	Strontium	Sr
Germanium	Ge	Sulfur	S
Gold, aurum	Au	Tantalum	Ta
Hafnium, celtium	Hf	Technetium	Tc
Helium	He	Tellurium	Te
Holmium	Ho	Terbium	Tb
Hydrogen	H	Thallium	Tl
Indium	In	Thorium	Th
Iodine	I	Thulium	Tm
Iridium	Ir	Tin, stannum	Sn
Iron, ferrum	Fe	Titanium	Ti
Krypton	Kr	Tungsten	W
Lanthanum	La	Uranium	U
Laurencium	Lw	Vanadium	V
Lead, plumbum	Pb	Xenon	Xe
Lithium	Li	Ytterbium	Yb
Lutetium	Lu	Yttrium	Y
Magnesium	Mg	Zinc	Zn
		Zirconium	Zr

TAPE, PRESSURE SENSITIVE (ADHESIVE), ADHESIVES, GASSES AND CERAMIC MOLDING MATERIAL

SECTION 4

TABLE OF CONTENTS

	PAGE(S)
TAPE, PRESSURE SENSITIVE, ADHESIVE	4-2 THRU 4-4
ELECTROLYTIC COPPER FOIL	4-5
ELECTROLYTIC ALUMINUM FOIL	4-5
ADHESIVES	4-6
GASSES	4-7
DEHYDRATING AGENT	4-7
CERAMIC MOLDING MATERIAL	4-8
UPDATES & NOTES	4-9
CROSS REFERENCE INDEX	4-10 THRU 4-12

4

COST CODE (CC COLUMN)

CODE	≈ VALUE with -	≈ VALUE no suffix	≈ VALUE with +
A	.2¢	.5¢	.75¢
B	1.25¢	1.5¢	2¢
C	2.5¢	3¢	3.75¢
D	4.25¢	5¢	6¢
E	7¢	8¢	10¢
F	13¢	15¢	18¢
G	22¢	25¢	35¢
H	40¢	50¢	60¢
I	65¢	75¢	\$1
J	\$1.25	\$1.50	\$2
K	\$2.50	\$3	\$3.75
L	\$4.25	\$5	\$6
M	\$7	\$8	\$10
N	\$13	\$15	\$18
O	\$22	\$25	\$35+

NOTE: Costs may vary from order to order
due to order quantities, vendor, etc.

TAPE, PRESSURE SENSITIVE, ADHESIVE

DIMENSIONS		MATERIAL	REMARKS	PART NUMBER	CC
THICKNESS	WIDTH (IN)				
.0005	x .357	Black Paper Mylar	Permacel #P236	253-0243-00	ft A+
.001	x .375	Polyester	Permacel #P250	253-0252-00	rl K-
.001	x .375	White Polyester Film	3M #55	253-0076-00	ft B-
.001	x .437	White Polyester Film	3M #55	253-0077-00	ft A+
.001	x .500	Polyester	Permacel #252 PDS	253-0019-00	ft B-
.001	x .500	Nylon (Polyamide)	Mystik Kapton or Equivalent	253-0145-00	rl L+
.001	x .687	Polyester	Permacel #252	253-0065-00	ft B
.001	x .750	Nylon (Polyamide)	Mystik Kapton	253-0144-00	rl M
.001	x 1.000	Nylon (Polyamide)	Mystik Kapton	253-0143-00	rl M+
.001	x 1.000	Polyester	3M #74, Yellow	253-0228-00	ft C-
.0012	x .500	Print Cloth	Permacel #P600	006-0674-00	rl J-
.0012	x .750	Print Cloth	Permacel #P600	006-0675-00	rl J+
.002	x .096	Polyester	Brady B-123	253-0087-00	ft D
.002	x .250	Mylar (With Reflective Silver Coating)		253-0187-00	ft D
.002	x .750	Adhesive, Double Sided	3MX-1140	253-0079-00	ft B+
.002	x .750	Teflon Film, Transparent	Temp-R-Tape C Operating Temp -100 to 400°C	253-0039-00	ft G
.002	x 1.250	Silicone Rubber		253-0136-00	ft F-
.002	x 1.875	Asbestos Paper/Polyester	CFAM - 31	253-0102-00	ft C
.002	x 2.000	Asbestos Paper/Polyester	CFAM - 31	253-0090-00	ft C-
.002	x 2.250	Asbestos Paper/Polyester		253-0107-00	ft B
.002	x 3.000	Asbestos Paper/Polyester	CFAM - 31	253-0118-00	ft C-
.0023	x .062	Polyester Film		253-0281-00	ft C-
.0025	x .130	Polyester	Brady B-123	253-0086-00	ft D-
.0025	x .150	Polyester Film	3M #56, Yellow	253-0191-00	ft A+
.0025	x .188	Polyester Film	3M #56, Yellow	253-0151-00	ft A
.0025	x .250	Polyester Film	3M #59	253-0049-00	ft A
.0025	x .250	Polyester Film	3M #56	253-0021-00	ft A
.0025	x .300	Polyester Film	3M #56	253-0304-00	ft A+
.0025	x .328	Polyester Film	3M #56, Yellow	253-0084-00	ft A+
.0025	x .375	Polyester Film	3M #56, Yellow	253-0125-00	ft A+
.0025	x .375	Polyester Film	Scotch #59	253-0055-00	ft A+
.0025	x .437	Polyimide Film	3M	253-0297-00	ft E
.0025	x .437	Polyester Film	3M #56, Yellow	253-0103-00	ft B-
.0025	x .500	Polyester Film	Scotch #59	253-0047-00	ft B-
.0025	x .625	Polyester Film	Permacel P-231	253-0298-00	ft C-
.0025	x .750	Polyester Film	3M #56, Yellow	253-0196-00	ft C-
.0025	x .812	Polyester Film	3M #56, Yellow	253-0175-00	ft C
.0025	x 1.000	Polyester Film	3M #56, Yellow	253-0091-00	ft C-
.0025	x 1.000	Polyester	Scotch #5 Electrical Tape	253-0140-00	ft B+
.0025	x 1.062	Polyester Film	3M #56, Yellow	253-0240-00	ft C
.0025	x 1.125	Polyester Film	3M #56, Yellow	253-0229-00	ft C
.0025	x 1.250	Polyester Film	3M #56, Yellow	253-0227-00	ft C
.0025	x 1.375	Polyester Film	3M #56, Yellow	253-0054-00	ft C-
.0025	x 2.000	Polyester Film	Scotch #59	253-0063-00	ft C+
.00275	x .500	Polyester Film	Heat Shrinkable 3M #1179	253-0097-00	ft C-
.003	x .094	Polyester	Mystik 7300	253-0119-00	ft A
.003	x .125	Polyester	Mystik 7300	253-0114-00	ft C-
.003	x .180	Polyester	Mystik 7300	253-0060-00	ft A
.003	x .220	Polyester	Mystik 7300	253-0104-00	ft B
.003	x .250	Polyester	Mystik 7300	253-0115-00	ft B-
.003	x .375	Teflon	3M #63	253-0032-00	ft E
.003	x .875	Polyimide	Hi-Temp Silicone Adhesive/80° Range Temp, P221	253-0202-00	ft F+
.0035	x .150	Teflon	3M #60	253-0088-00	ft D+
.0035	x .250	Polyester Film	3M #75 Double Sided Adhesive	253-0221-00	ft B
.0035	x .375	Polyester Film	3M #75 Double Sided Adhesive	253-0219-00	in A-
.0035	x .438	Polyester Film	3M #75 Double Sided Adhesive	253-0234-00	ft C+
.0035	x .500	Polyester Film	3M #75 Double Sided Adhesive	253-0174-00	ft C
.0035	x .563	Polyester Film	3M #75 Double Sided Adhesive	253-0255-00	ft C
.0035	x .750	Polyester Film	3M #75 Double Sided Adhesive	253-0197-00	ft C-
.0035	x .813	Polyester Film	3M #75 Double Sided Adhesive	253-0254-00	ft D-
.0035	x 1.000	Teflon	Permacel P423, Natural	253-0142-00	rl O+
.0035	x 1.000	Polyester Film	3M #75 Double Sided Adhesive	253-0161-00	ft D+
.0035	x 1.250	Polyester Film	3M #75 Double Sided Adhesive or Permacel #P-257	253-0274-00	rl M-
.005	x .1875	Polyester		253-0279-00	rl J-
.005	x .250	Polyester	Polyken #765 or Equivalent	253-0182-00	ft A
.005	x .312	Polyester	Polyken #765 or Equivalent	253-0138-00	ft B-
.005	x .375	Polyester	Polyken #765 or Equivalent	253-0157-00	ft B-
.005	x .375	Vinyl	3M #471 or Equivalent	253-0204-00	ft B+
.005	x .500	Polyester Web	3M #44 or Equivalent	253-0284-00	ft A+
.005	x .625	Polyester	3M	253-0291-00	ft B+
.005	x .750	Vinyl	3M #471 or Equivalent	253-0131-00	ft B
.005	x .750	Polyester Film	3M #44	253-0292-00	ft B
.005	x 1.000	Paper	3M #10	253-0283-00	rl M
.005	x 12.000	Silicone Coated Paper Liner/ Acrylic Polymer	3M Y-9469	253-0299-00	ft H+

TAPE, PRESSURE SENSITIVE, ADHESIVE (CONT)

DIMENSIONS		MATERIAL	REMARKS	PART NUMBER	CC	
THICKNESS	WIDTH (IN)					
.005	x 24.000	Silicone Coated Paper Liner/ Acrylic Polymer	94469	253-0259-00	ft	I+
.0055	x .500	Paper	Permacec #275 or Equivalent	253-0206-00	ft	A+
.0055	x 1.438	Paper	Permacec #275 or Equivalent	253-0212-00	ft	C-
.006	x .250	Polyester Film/Paper	Permacec #248 or Equivalent	253-0207-00	ft	A
.006	x .500	Polyester Film/Paper	Permacec #248 or Equivalent	253-0205-00	ft	A+
.006	x .625	Polyester Film/Paper	Permacec #246 or Equivalent	253-0217-00	ft	A
.006	x .750	Polyester Film/Paper	Permacec #248 or Equivalent	253-0237-00	ft	B
.006	x .750	Creped Paper	Mystik 6215	006-0683-00	rl	I-
.006	x .875	Polyester Film/Paper	Permacec #248 or Equivalent	253-0232-00	ft	C-
.006	x 1.000	Polyester Film/Paper	Permacec #248	253-0293-00	ft	B+
.006	x 1.062	Polyester Film/Paper	Permacec #248 or Equivalent	253-0230-00	ft	C-
.006	x 1.156	Polyester Film/Paper	Permacec #248 or Equivalent	253-0238-00	ft	C-
.006	x 1.188	Polyester/Glass Filament	Permacec P246 (package in 60 yard rolls)	253-0269-00	ft	C+
.006	x 1.250	Polyester Film/Paper	Permacec #248 or Equivalent	253-0246-00	ft	C-
.006	x 1.375	Polyester/Glass Filament	Permacec P246 (package in 60 yard rolls)	253-0268-00	ft	D
.006	x 1.375	Tan Polyester Film/Paper	Permacec #P248	253-0280-00	ft	C
.006	x 1.438	Polyester Film/Paper	Permacec #248 or Equivalent	253-0211-00	ft	C
.006	x 1.656	Polyester Film/Paper	Permacec #248 or Equivalent	253-0239-00	ft	C
.006	x 2.000	Creped Paper	Mystik 6215	006-0684-00	rl	J+
.006	x 2.000	Impregnated Rope	Permacec #72	006-0687-00	rl	L
.0065	x .250	Paper Masking, High Temperature	Permacec #703	006-0682-00	rl	I-
.0065	x .500	Rope Stock Paper	Mystik #6325	006-0116-00	rl	J+
.0065	x .500	Paper Masking, High Temperature	Permacec #702	006-0685-00	rl	J+
.0065	x .750	Paper Masking, High Temperature	Permacec #703	006-0314-00	rl	J+
.0065	x 1.000	Paper Masking, High Temperature	Permacec #703	006-1069-00	rl	K-
.0065	x 2.000	Paper Masking, High Temperature	Permacec #703	006-1863-00	rl	L+
.007	x .500	White Glass Cloth	Permacec #21	253-0013-00	gt	C-
.007	x .750	Fiberglass	3M #32	253-0078-00	ft	E+
.007	x .875	Acetate Film w/Glass Filament	3M #46 or Equivalent	253-0149-01	ft	C-
.007	x 1.125	Acetate Film w/Glass Filament	3M #46 or Equivalent	253-0149-00	ft	D
.007	x 3.000	Glass Cloth	Permacec #213	253-0199-00	ft	F-
.0075	x 1.437	Glass Cloth	3M #79	253-0303-00	ft	E
.0075	x 1.500	Glass Cloth	Permacec #213	253-0241-00	ft	D+
.008	x .005	White Acetate Cloth	Permacec #24	253-0015-00	ft	B
.008	x .250	White Glass Cloth	3M #27	253-0071-00	ft	B-
.008	x .250	White Acetate Cloth	3M #28	253-0171-00	ft	A+
.008	x .312	White Acetate Cloth	3M #28	253-0216-00	ft	B-
.008	x .375	White Acetate Cloth	3M #28	253-0179-00	ft	B-
.008	x .562	White Polyester Film	3M #55	253-0072-00	rl	L
.008	x .687	White Polyester Film	3M #55	253-0059-00	ft	C
.008	x .781	White Polyester Film	3M #55	253-0066-00	ft	C
.008	x 1.000	Black Acetate Cloth	3M #11	253-0062-00	rl	L+
.008	x 1.375	White Acetate Cloth	Permacec #24	253-0210-00	rl	M+
.008	x 1.500	Black Acetate Cloth	3M #11	253-0201-00	rl	M
.008	x 2.750	Teflon	Permacec #422	253-0189-00	rl	O+
.0085	x .250	Black Acetate Cloth	3M #11	253-0126-00	ft	A+
.0085	x .375	Black Acetate Cloth	3M #11 or Equivalent	253-0117-00	ft	B-
.0085	x .594	Black Acetate Cloth	3M #11 or Equivalent	253-0130-00	ft	C-
.0085	x .812	Black Acetate Cloth	3M #11 or Equivalent	253-0070-00	ft	C
.0085	x 1.218	Black Acetate Cloth	3M #11	253-0051-00	ft	C+
.0085	x 1.250	Black Acetate Cloth	3M #11 or Equivalent	253-0116-00	ft	C+
.0085	x 1.500	Black Acetate Cloth	3M #11	253-0064-00	ft	D
.0095	x 3.000	Waterproofed Polyethylene Coated Cloth	Permacec #P670	006-1799-00	rl	L+
.010	x .125	Vinyl Covered Cloth	Mystik 5863	253-0120-00	ft	C-
.010	x .500	Nylon Paper	Nomex M Type E-58	253-0152-00	ft	C+
.010	x .625	Nylon Paper	Nomex M Type E-58	253-0185-00	ft	D+
.010	x .750	Vinyl Film	Permacec P30-105	253-0236-00	ft	C
.020	x 1.250	Silicone Rubber, Red	Permacec #P2650	253-0137-00	ft	G+
.062	x .166	Silicone Sponge	Cohrlastic, Adhesive One Side	253-0253-00	ft	G-
.062	x .250	Polyurethane Sponge	3M #4116	253-0160-00	ft	D-
.062	x .375	Open Cell Polyurethane	3M #4016 Double Sided Adhesive	253-0218-00	rl	L-
.062	x .375	Polyurethane Sponge	3M #4116	253-0192-00	rl	L+
.062	x .500	Silicone Sponge Rubber		253-0198-00	ft	E+
.062	x .500	Vinyl Foam	Double Sided Adhesive	253-0176-00	ea	B-
.062	x .500	Vinyl Foam, Double Sided	3M	253-0135-00	ft	C
.062	x .750	Polyurethane Sponge	3M #4116	253-0056-00	ft	E
.062	x 1.500	Polyurethane Sponge	3M #4116	253-0184-00	ft	F
.094	x .500	Silicone Sponge Foam	CHR-R-10470	252-0635-00	rl	N-
.125	x .125 x 36	Silicone Sponge	Dark Blue-Gray	348-0524-00	ea	H-
.125	x .250	Foam	.250 dia. dots, Adhesive Both Sides	253-0154-00	ea	B+
.125	x .250	Foam	Wilshire V-7	253-0153-00	ft	C+
.125	x .250	Polyester Foam	Gray; with Adhesive One Side	252-0603-00	ft	B+
.125	x .375	Silicone Sponge Foam	CHR-R-10470	253-0248-00	ft	G+
.125	x .500	Polyurethane Foam	Permacec #PJ25F	255-0569-00	rl	J+

TAPE, PRESSURE SENSITIVE, ADHESIVE (CONT)

DIMENSIONS		MATERIAL	REMARKS	PART NUMBER	CC	
THICKNESS	WIDTH (IN)					
.125	x .500	Polyurethane Foam	Adhesive One Side	255-0647-00	ft	E
.125	x .750	Urethane Foam	3M #4008	253-0188-00	rl	M+
.125	x 4.000	Urethane Foam, Black		253-0083-00	ft	E+
.156	x .375	Foam	Dutch Brand DV3719	253-0164-00	ft	E
.250	x .250	Urethane Foam		252-0651-00	ft	H-
.250	x .250	Urethane Foam	Tesamoll #2	253-0095-00	ft	C-
.250	x .375	Urethane Foam, Gray		253-0045-00	ft	E+
.250	x .500	Polyurethane		253-0101-00	rl	L
.250	x .750	Urethane Foam, Black	Tesamoll #3	253-0028-00	ft	H-
	.250	Adhesive, Double Sided	3M #465	253-0075-00	ft	B-
	.250	Aluminum Backing	Mystik #7402	253-0132-00	ft	C-
.250	x 10.000	Adhesive, Double Sided	3M #465	253-0052-00	ft	G-
.300	x .300	Epoxy Film	3M #10	253-0277-00	rl	O-
	.375	Epoxy Coated Polyester Web	3M X1277 or Equivalent	253-0190-00	ft	C-
.500	x .375	Urethane Foam, Black	Tesamoll #2	253-0044-00	rl	K+
.500	x .625	Adhesive, Double Sided	3M #468	255-0576-00	ea	D
	.625	Velcro Loop, Black		252-0696-00	ft	G+
	.750	Electropl Vinyl, Yellow		006-1039-00	rl	K
	1.000	Velcro Loop, Beige		252-0697-00	ft	G+
	1.000	Velcro Hook, White (Mates w/253-0273-00)	3M SJ-3536 (Packaged in 25 yard rolls)	253-0272-00	ft	G+
	1.000	Velcro Loop, White (Mates w/253-0272-00)	3M SJ-3537 (Packaged in 25 yard rolls)	253-0273-00	ft	G+
	1.000	Velcro Hook (Mates w/252-0684-00)		252-0683-00	ft	H+
	1.000	Velcro Loop (Mates w/252-0683-00)		252-0684-00	ft	G+
	1.500	Polyester/Glass Filament	Permacel P246	253-0270-00	ft	D

COST CODE

(CC COLUMN)

CODE	≈ VALUE with -	≈ VALUE no suffix	≈ VALUE with +
A	.2¢	.5¢	.75¢
B	1.25¢	1.5¢	2¢
C	2.5¢	3¢	3.75¢
D	4.25¢	5¢	6¢
E	7¢	8¢	10¢
F	13¢	15¢	18¢
G	22¢	25¢	35¢
H	40¢	50¢	60¢
I	65¢	75¢	\$1
J	\$1.25	\$1.50	\$2
K	\$2.50	\$3	\$3.75
L	\$4.25	\$5	\$6
M	\$7	\$8	\$10
N	\$13	\$15	\$18
O	\$22	\$25	\$35+

NOTE: Costs may vary from order to order
due to order quantities, vendor, etc.

TAPE, PRESSURE SENSITIVE, ADHESIVE (CONT)

ELECTROLYTIC COPPER FOIL

DIMENSIONS		MATERIAL	REMARKS	PART NUMBER	CC	
THICKNESS	WIDTH (IN)					
.0007	.750	Tefco T-25F		253-0220-00	ft	F+
.0010	1.250	Tru-Tek	7 Strips on 12 inch Mylar	253-0165-00	ft	J+
.0010	1.625	Tru-Tek	6 Strips on 12 inch Mylar	253-0166-00	ft	J+
.0014	.562	Permace1 P389	Packaged in 36 yard rolls	253-0264-00	ft	G
.0014	.937	Permace1 EE-3990	Packaged in 36 yard rolls	253-0128-00	ft	E-
.0014	1.250	Permace1 EE-3990	Packaged in 36 yard rolls	253-0074-00	ft	F+
.0014	1.625	Permace1 EE-3990	Packaged in 36 yard rolls	253-0093-00	ft	G
.0014	1.750	Permace1 EE-3990	Packaged in 36 yard rolls	253-0033-00	ft	G
.0014	2.000	Permace1 EE-3990	Packaged in 36 yard rolls	253-0023-00	ft	G
.0014	2.750	Permace1 EE-3990	Packaged in 36 yard rolls	253-0024-00	ft	G+
.0016	.500	Permace1 389	Packaged in 36 yard rolls	253-0247-00	ft	E-
.0016	.625	Permace1 389	Packaged in 60 yard rolls	253-0245-00	ft	E+
.0016	.750	3M 1194	Packaged in 25 yard rolls	253-0266-00	ft	E+
.0016	.875	Permace1 389	Packaged in 36 yard rolls	253-0244-00	ft	F-
.0016	1.062	Permace1 389	Packaged in 36 yard rolls	253-0251-00	ft	F+
.0016	1.375	Permace1 389	Packaged in 36 yard rolls	253-0257-00	ft	F-
.0016	2.312	Permace1 EE-3990	Packaged in 36 yard rolls	253-0226-00	ft	F
.004	.3125	Permace1 or 3M	Packaged in 36 yard rolls	253-0296-00	ft	E
.004	2.625	Permace1 389	Packaged in 36 yard rolls	253-0262-00	ft	G+
.005	.375	Fralock/Tru-Tek	Packaged in 25 yard rolls	253-0288-00	ft	E+
.005	.690	Fralock/Tru-Tek	Packaged in 25 yard rolls	253-0289-00	r1	N+
.005	.750	Fralock	Packaged in 25 yard rolls	253-0294-00	r1	N+
.005	.875	Fralock	Packaged in 25 yard rolls	253-0300-00	ft	G+
.005	1.281	Fralock/Tru-Tek T-0502	Packaged in 25 yard rolls	253-0282-00	r1	O+
.005	1.359	Fralock	Packaged in 72 yard rolls	253-0301-00	ft	H
.005	1.500	Alloy 110	Packaged in 72 yard rolls	253-0301-01	ft	H
.005	1.625	Fralock	Packaged in 25 yard rolls	253-0295-00	ft	H+
.005	2.000	Fralock	Packaged in 25 yard rolls	253-0302-00	ft	I-
.005	2.312	Fralock/Tru-Tek	Packaged in 25 yard rolls	253-0290-00	ft	H+

ELECTROLYTIC ALUMINUM FOIL

DIMENSIONS		MATERIAL	REMARKS	PART NUMBER	CC	
THICKNESS	WIDTH (IN)					
.055	.500	Scotch 1170		253-0155-00	ft	B+
	1.000	Scotch X-1170		253-0148-00	ft	F+
.0055	.750	Scotch X-1170	Resistance Through Tape .1 Ω /square inch	253-0225-00	r1	N+
.0055	1.500	Scotch X-1170	Resistance Through Tape .1 Ω /square inch	253-0224-00	in	D

4

ADHESIVES

TYPE/NAME	REMARKS	MANUFACTURER & NUMBER	PART NUMBER	CC
Ablebond 71-2		Ablestick Laboratories	006-2971-00	jr O+
Ablebond 163-4		Ablestick Laboratories	006-3411-00	lb O+
Ablestick		877-1	006-2570-00	ea K-
Acrylic		Zip Grip #10	006-2196-00	tu N-
Acrylic		Zip Grip #10	006-2196-01	tu J-
Bond	3.500 ounces	Bond #5032	006-0533-00	tu J+
Cement	Gypsum, Ultra Cal 30	Dealers Supply Company	006-1217-00	bg N-
Contact		Permabond White Label	006-1685-00	bt L-
Contact Cement		Permabond Blue Label	006-2313-00	bt K+
Contact Cement		3M #EC-847	006-0367-00	qt M+
Contact Cement	Water based		006-4380-00	gl N+
Contact Cement	Quick drying		006-4379-00	gl N-
Contact Cement		3M #EC-847	006-0367-01	tu J+
Contact Cement	Glue Stick	Faber Castell U75	002-1415-00	ea H+
Contact Cement		Casco Borden's S0-33	006-1178-00	gl L
Contact Cement		Permabond Yellow Label	006-2314-00	bt L-
Duco Household	1.750 ounces		006-0532-00	tu H+
Ecconobond #281		Emerson & Cuming	006-3164-00	ea O-
Epoxy	Structural	Conap AD-3	252-0276-00	lb I+
Epoxy Kit	Hysol #1C	Hysol #1C	006-0217-00	ea K-
Epoxy Kit	Black	Hysol #11-C	006-4401-00	ea K-
Epoxy Kit	Clear	Hysol #0151	006-4402-00	ea K+
Epoxy Kit	Clear, Super Quick Set	Hysol #6008	006-4403-00	ea K+
Epoxy Kit	Gray, Super Quick Set	Hysol #309	006-4404-00	ea L-
Epoxy, 2 Part		Woodhill EPX-1C	252-0200-00	ea I
Epoxy, 2 Part, Thixotropic		Eccobond #285	006-1757-00	ea O-
Epoxy, Thixotropic		Atacs Products D-276	252-0731-00	ea
Glue, Elmers			006-4381-00	gl M-
Loctite	Structural	Electrical Specialty #325-55	006-2954-00	tu M+
Loctite		Superbond #04E	006-2366-00	tu J-
Loctite		Screw Lock #222-21	006-2517-00	bt K+
Loctite		Thread Lock #290-31	006-2579-00	ea M
Loctite		#414-50 SuperBonder	006-2712-00	bt M
Loctite	Cyanocrylate, Ester based	Loctite 00216	006-4466-00	ea N-
Loctite		#422-50 SuperBonder	006-2848-00	bt K+
Paper Cement, Best Test			002-0019-00	pt J+
Paste	Mixed Bonded Gold	Alcoa #6240	252-0658-00	qt H+
Paste	(85% Solids)	AVX Materials, AVX 3525	256-0696-00	gr N+
Paste	Multilayer, Dielectric	Electro Material Corp. of America, #9121	256-0698-00	gr I+
Paste	Electrode Abrasive	Day-Baldwin, Inc.	006-1098-00	tu I-
Paste, Conductive	Saline Gel			
Paste, Conductive	Silver Filled Epoxy	Ablestick Laboratories	006-3638-00	oz 0
Paste, Conductive	Gold	Owens-Corning 6985	256-0640-00	gr 0-
Paste, Conductive	Gold, 7185	Electro Oxide Corp. 7185	256-0693-00	gr 0-
Paste, Conductive	Refractory Metal		256-0688-00	gr
Paste, Conductive	Gold Filled Epoxy	Epoxy Technology, H41	256-0702-00	
Paste, Conductive	Palladium, Platinum and Silver	Dupont D4093	256-0694-00	gr K+
Paste, Resistor	Thermally Sensitive	Thick Film Systems	256-0697-00	gr L
Paste, Solder	Dielectric	Dupont DP9429	256-0664-00	gr I
Paste, Solder	Multicore	Dupont DP8922	256-0665-00	gr F-
Paste, Solder	85% metal, 15% RMA flex	Indium IPN-80913 COMP SN62	256-0701-00	lb L-
Plastic Resin	Weldwood	All Purpose Spray	006-2458-00	cn L
Silicone Rubber		Chromerics 50-02-1030-000	006-3217-00	tu 0
Silicone Rubber	3 ounces	GE RTV-116 Red	252-0682-00	tu K
Silicone Rubber	Flame Retardant	GE RTV-133 Black	252-0718-00	ea N-
Silicone Rubber	2 Part	Dow Corning Q3-6567	253-0276-00	oz L
Vinyl		3M #2262	252-0156-00	qt M
Vinyl, Vyna-Kote	Clear	Spectra Strip	252-0029-00	bt J+

GASSES

TYPE OR MIX	CONTAINER	PART NUMBER	CC
Acetylene	#3		100 cu ft L
Acetylene	#4		100 cu ft M+
Acetylene	#5		100 cu ft N+
Acetylene	MCPOL		cy L
Acetylene	BPOL		cy M-
Air	224 cu ft		cy M
Anhydrous Ammonia	#150	006-0464-00	cy O+
Argon	330 cu ft		cy N-
Arsine, 15% in Hydrogen		006-3149-00	cy O+
Arsine, 70 ppm, in Hydrogen	1D	006-1864-00	cy O+
Boron Trichloride		006-3639-00	cy O+
Carbon Dioxide	50# syphon		cy L+
Freon 116		006-3484-00	cy O+
Freon		006-3640-00	gl N-
Helium	285 cu ft		cy 0
Helium, Ultra High Purity		006-3493-00	r1 K
Hydrogen	194 cu ft		cy M
Hydrogen, 10% in Nitrogen	206 cu ft		cy M+
Hydrogen, 15% in Nitrogen	224 cu ft		cy N-
Hydrogen, 21% in Nitrogen	224 cu ft		
Hydrogen, 40% in Nitrogen	80 cu ft		M+
Hydrogen Chloride, 100%	1A	006-2932-00	cy O+
Nitrogen, Liquid	#297		cy N-
Nitrogen, Oil Pumped	224 cu ft		cy K+
Nitrogen, Water Pumped	224 cu ft		cy K+
Oxygen	80 cu ft		cy K
Oxygen	122 cu ft		cy K
Phosphine, 3% in Nitrogen		006-3485-00	cy L+
Phosphine, 1% in Nitrogen		006-2389-00	cy O+
Phosphine, 15% in Hydrogen		006-3148-00	cy O+
Propane	5 gal		cy K+
Propane	10 gal		cy M
Silane	1X	006-1852-00	cy O+
Silane, 10% in Hydrogen	2D	006-1851-00	cy O+
Silane, 10% in Hydrogen	1D	006-1866-00	cy O+

NOTE: THE COST FIGURES REFERENCED ARE FOR THE GAS ONLY. THERE IS ALSO A CYLINDER RENTAL CHARGED ON A PER DAY BASIS AFTER 30 DAYS.

DEHYDRATING AGENT (DESICCANT)

MATERIAL	REMARKS	PART NUMBER	CC
Silica Gel	Metal Air Dryers	256-0570-00	ea J+

4

CERAMIC MOLDING MATERIAL

DESCRIPTION	PART NUMBER	CC
Lead Oxide	006-1042-00	1b K+
Titanium Dioxide Reagent	006-1043-00	1b L-
Alundun Oxide	006-1142-00	1b I+
Magnesium Oxide, USP #6010 Malin KRODT	006-2414-00	oz A (1b/K-)
Sodium Sulfide, Anhydrous Reagent	006-3499-00	1b J+
Feldspathic P100 (Porcelain Compound)	252-0107-00	
Steatite P101 (Porcelain Compound)	252-0108-00	
Alumina, P103A-0 Extrusion	252-0109-02	
Alumina, A126, Pink	252-0115-01	
Alumina, A126, Green	252-0115-02	
Alumina, A126, Black	252-0115-03	
Alumina, A126, White Extrusion	252-0115-04	
Alumina, 96%	252-0168-00	
Barium Carbonate	256-0510-00	1b H-
Silver Bond, 325 Mesh Silica Clay	256-0513-00	1b F+
Tennessee #1 Ball Clay	256-0515-00	1b I+
Kingman Feldspar	256-0517-00	1b E
SAF (Standard Air Flow) Georgia Clay	256-0520-00	1b E
A-400 Nepheline Syenite	256-0523-00	1b E
Superpax "A"	256-0530-00	1b I
Snowflake (Calcium Carbonate) Whiting	256-0531-00	1b E+
Zinc Oxide	256-0532-00	1b H+
Polyfon T (wetting agent)	256-0549-00	1b G
Cobalt Carbonate	256-0551-00	1b N
A-14 Alumina	256-0554-00	1b G
Yellowstone Talc	256-0559-00	1b E+
Talcron 45-26	256-0569-00	1b D
Carbowax 4000 (binder)	256-0571-00	1b I
Barium Titante K-4000	256-0584-00	1b L+
Barium Titante K-200	256-0591-00	
Kaiser MGO (Magnesium Oxide)	256-0593-00	1b G
Darvan #7 (wetting agent)	256-0604-00	1b G+
Permanente #98 Perclase (Castable Ceramic Material)	256-0605-00	1b G-
Sodium Hexa-Meta Phosphate	256-0606-00	1b H
Barium Titanate K-38	256-0611-00	oz F
MP-98-25 Cercron Talc	256-0613-00	1b D
MP-99-54 Cercron Talc	256-0614-00	1b F+
Polyglycol P-1200	256-0617-00	1b I
Marasperse (wetting agent)	256-0618-00	1b G
Rhoplex AC-33X (binder)	256-0620-00	1b H
Dielectric Composition (#8299 Crystallizable Glass)	256-0630-00	gr J-
Nickel Oxide	256-0634-00	1b K
Dimethyl Formamide	256-0667-00	g1 M-
Alumina (RC 20 GF)	256-0678-00	1b G-
Magnesium Carbonate	256-0679-00	1b H
Alumina Oxide	256-0680-00	1b F
Polyethylene Glycol	256-0681-00	1b J-
Alumina (C72RG)	256-0686-00	1b F
Strontium Zirconate	256-0700-00	1b L-

COST CODE

(CC COLUMN)

CODE	A	B	C	D	E	F	G	H	I	J	K	L	M	N	O
≈ VALUE with +	.75¢	2¢	3.75¢	6¢	10¢	18¢	35¢	60¢	\$1	\$2	\$3.75	\$6	\$10	\$18	\$35+
≈ VALUE no suffix	.5¢	1.5¢	3¢	5¢	8¢	15¢	25¢	50¢	75¢	\$1.50	\$3	\$5	\$8	\$15	\$25
≈ VALUE with -	.2¢	1.25¢	2.5¢	4.25¢	7¢	13¢	22¢	40¢	65¢	\$1.25	\$2.50	\$4.25	\$7	\$13	\$22

NOTE: Costs may vary from order to order due to order quantities, vendor, etc.

UPDATES AND NOTES

COST CODE (CC COLUMN)

CODE	A	B	C	D	E	F	G	H	I	J	K	L	M	N	O
⌘ VALUE with +	.75¢	2¢	3.75¢	6¢	10¢	18¢	35¢	60¢	\$1	\$2	\$3.75	\$6	\$10	\$18	\$35+
⌘ VALUE no suffix	.5¢	1.5¢	3¢	5¢	8¢	15¢	25¢	50¢	75¢	\$1.50	\$3	\$5	\$8	\$15	\$25
⌘ VALUE with -	.2¢	1.25¢	2.5¢	4.25¢	7¢	13¢	22¢	40¢	65¢	\$1.25	\$2.50	\$4.25	\$7	\$13	\$22

NOTE: Costs may vary from order to order due to order quantities, vendor, etc.

CROSS REFERENCE INDEX

TAPE, PRESSURE SENSITIVE (ADHESIVE), ADHESIVES, GASSES AND CERAMIC MOLDING MATERIAL

PART NUMBER	DESCRIPTION	PAGE NO.	STATUS§§
002-0019-00	Adhesives	4-6	CR
002-1415-00	Adhesives	4-6	CR
006-0116-00	Tape, PSA	4-3	CR
006-0217-00	Adhesives	4-6	CR
006-0314-00	Tape, PSA	4-3	CR
006-0367-00	Adhesives	4-6	CR
006-0367-01	Adhesives	4-6	CR
006-0464-00	Gasses	4-7	CR
006-0532-00	Adhesives	4-6	CR
006-0533-00	Adhesives	4-6	CR
006-0534-00	Adhesives		DL
006-0639-00	Adhesives		DL
006-0674-00	Tape, PSA	4-2	CS
006-0675-00	Tape, PSA	4-2	CR
006-0682-00	Tape, PSA	4-3	CR
006-0683-00	Tape, PSA	4-3	CR
006-0684-00	Tape, PSA	4-3	CR
006-0685-00	Tape, PSA	4-3	CR
006-0687-00	Tape, PSA	4-3	CR
006-1039-00	Tape, PSA	4-4	CR
006-1042-00	Ceramic Molding Material	4-8	CR
006-1043-00	Ceramic Molding Material	4-8	CR
006-1069-00	Tape, PSA	4-3	CR
006-1098-00	Adhesives	4-6	CS
006-1142-00	Ceramic Molding Material	4-8	CR
006-1178-00	Adhesives	4-6	CR
006-1217-00	Adhesives	4-6	CR
006-1259-00	Adhesives		DL
006-1685-00	Adhesives	4-6	CR
006-1757-00	Adhesives	4-6	CR
006-1799-00	Tape, PSA	4-3	CR
006-1848-00	Gasses		DL
006-1849-00	Gasses		DL
006-1851-00	Gasses	4-7	CR
006-1852-00	Gasses	4-7	CR
006-1863-00	Tape, PSA	4-3	CR
006-1864-00	Gasses	4-7	CR
006-1865-00	Gasses		DL
006-1866-00	Gasses	4-7	CR
006-2196-00	Adhesives	4-6	CR
006-2196-01	Adhesives	4-6	CR
006-2313-00	Adhesives	4-6	CR
006-2314-00	Adhesives	4-6	CR
006-2366-00	Adhesives	4-6	CR
006-2389-00	Gasses	4-7	CR
006-2390-00	Gasses		DL
006-2414-00	Ceramic Molding Material	4-8	CR
006-2458-00	Adhesives	4-6	CR
006-2517-00	Adhesives	4-6	CR
006-2570-00	Adhesives	4-6	CR
006-2579-00	Adhesives	4-6	CR
006-2712-00	Adhesives	4-6	CR
006-2801-00	Ceramic Molding Material		DL
006-2823-00	Adhesives		DL
006-2848-00	Adhesives	4-6	CR
006-2932-00	Gasses	4-7	CR
006-2954-00	Adhesives	4-6	CR
006-2971-00	Adhesives	4-6	CR
006-3148-00	Gasses	4-7	CR
006-3149-00	Gasses	4-7	CR
006-3164-00	Adhesives	4-6	CR
006-3217-00	Adhesives	4-6	CR
006-3411-00	Adhesives	4-6	CR
006-3484-00	Gasses	4-7	CR
006-3485-00	Gasses	4-7	CR
006-3493-00	Gasses	4-7	CR
006-3499-00	Ceramic Molding Material	4-8	CR
006-3638-00	Adhesives	4-6	CR
006-3639-00	Gasses	4-7	CR
006-3640-00	Gasses	4-7	CR
006-4379-00	Adhesives	4-6	CR
006-4380-00	Adhesives	4-6	CR
006-4381-00	Adhesives	4-6	CR
006-4401-00	Adhesives	4-6	CR
006-4402-00	Adhesives	4-6	CR

PART NUMBER	DESCRIPTION	PAGE NO.	STATUS§§
006-4403-00	Adhesives	4-6	CR
006-4404-00	Adhesives	4-6	CR
006-4466-00	Adhesives	4-6	CR
252-0029-00	Adhesives	4-6	CR
252-0107-00	Ceramic Molding Material	4-8	CR
252-0108-00	Ceramic Molding Material	4-8	CR
252-0109-02	Ceramic Molding Material	4-8	CR
252-0115-01	Ceramic Molding Material	4-8	CR
252-0115-02	Ceramic Molding Material	4-8	CR
252-0115-03	Ceramic Molding Material	4-8	CR
252-0115-04	Ceramic Molding Material	4-8	CR
252-0156-00	Adhesives	4-6	CR
252-0168-00	Ceramic Molding Material	4-8	CR
252-0174-00	Adhesives		OB
252-0200-00	Adhesives	4-6	CS
252-0276-00	Adhesives	4-6	CR
252-0603-00	Tape, PSA	4-3	CR
252-0635-00	Tape, PSA	4-3	CR
252-0651-00	Tape, PSA	4-4	CR
252-0658-00	Adhesives	4-6	CR
252-0682-00	Adhesives	4-6	CR
252-0683-00	Tape, PSA	4-4	CR
252-0684-00	Tape, PSA	4-4	CR
252-0696-00	Tape, PSA	4-4	CR
252-0697-00	Tape, PSA	4-4	CR
252-0718-00	Adhesives	4-6	PP
252-0731-00	Adhesives	4-6	PP
253-0013-00	Tape, PSA	4-3	CR
253-0015-00	Tape, PSA	4-3	CR
253-0018-00	Tape, PSA		OB
253-0019-00	Tape, PSA	4-2	CR
253-0021-00	Tape, PSA	4-2	CR
253-0023-00	Electrolytic Copper Foil	4-5	CR
253-0024-00	Electrolytic Copper Foil	4-5	CR
253-0028-00	Tape, PSA	4-4	CR
253-0032-00	Tape, PSA	4-2	CR
253-0033-00	Electrolytic Copper Foil	4-5	CR
253-0039-00	Tape, PSA	4-2	OB
253-0044-00	Tape, PSA	4-4	CR
253-0045-00	Tape, PSA	4-4	CR
253-0047-00	Tape, PSA	4-2	CR
253-0049-00	Tape, PSA	4-2	CS
253-0051-00	Tape, PSA	4-3	CR
253-0052-00	Tape, PSA	4-4	CR
253-0054-00	Tape, PSA	4-2	CR
253-0055-00	Tape, PSA	4-2	CR
253-0056-00	Tape, PSA	4-3	CR
253-0059-00	Tape, PSA	4-3	CR
253-0060-00	Tape, PSA	4-2	CR
253-0062-00	Tape, PSA	4-3	CR
253-0063-00	Tape, PSA	4-2	CR
253-0064-00	Tape, PSA	4-3	CR
253-0065-00	Tape, PSA	4-2	CR
253-0066-00	Tape, PSA	4-3	CR
253-0070-00	Tape, PSA	4-3	CR
253-0071-00	Tape, PSA	4-3	CR
253-0072-00	Tape, PSA	4-3	CR
253-0074-00	Electrolytic Copper Foil	4-5	CR
253-0075-00	Tape, PSA	4-4	CR
253-0076-00	Tape, PSA	4-2	CR
253-0077-00	Tape, PSA	4-2	CS
253-0078-00	Tape, PSA	4-3	CR
253-0079-00	Tape, PSA	4-2	CR
253-0083-00	Tape, PSA	4-4	CR
253-0084-00	Tape, PSA	4-2	CR
253-0086-00	Tape, PSA	4-2	CR
253-0087-00	Tape, PSA	4-2	CR
253-0088-00	Tape, PSA	4-2	CR
253-0090-00	Tape, PSA	4-2	CS
253-0091-00	Tape, PSA	4-2	CR
253-0093-00	Electrolytic Copper Foil	4-5	CR
253-0095-00	Tape, PSA	4-4	OB
253-0097-00	Tape, PSA	4-2	CR
253-0101-00	Tape, PSA	4-4	EN
253-0102-00	Tape, PSA	4-2	CR

CROSS REFERENCE INDEX

TAPE, PRESSURE SENSITIVE (ADHESIVE), ADHESIVES, GASSES AND CERAMIC MOLDING MATERIAL

4

PART NUMBER	DESCRIPTION	PAGE NO.	STATUS§§
253-0103-00	Tape, PSA	4-2	CR
253-0104-00	Tape, PSA	4-2	CR
253-0107-00	Tape, PSA	4-2	CR
253-0114-00	Tape, PSA	4-2	CR
253-0115-00	Tape, PSA	4-2	CR
253-0116-00	Tape, PSA	4-3	CR
253-0117-00	Tape, PSA	4-3	CR
253-0118-00	Tape, PSA	4-2	CS
253-0119-00	Tape, PSA	4-2	CR
253-0120-00	Tape, PSA	4-3	CR
253-0125-00	Tape, PSA	4-2	CR
253-0126-00	Tape, PSA	4-3	CR
253-0128-00	Electrolytic Copper Foil	4-5	CR
253-0130-00	Tape, PSA	4-3	CR
253-0131-00	Tape, PSA	4-2	CR
253-0132-00	Tape, PSA	4-4	CR
253-0135-00	Tape, PSA	4-3	CR
253-0136-00	Tape, PSA	4-2	CS
253-0137-00	Tape, PSA	4-3	CR
253-0138-00	Tape, PSA	4-2	CR
253-0140-00	Tape, PSA	4-2	CR
253-0142-00	Tape, PSA	4-2	CR
253-0143-00	Tape, PSA	4-2	CR
253-0144-00	Tape, PSA	4-2	CR
253-0145-00	Tape, PSA	4-2	CR
253-0148-00	Electrolytic Aluminum Foil	4-5	CS
253-0149-00	Tape, PSA	4-3	CR
253-0149-01	Tape, PSA	4-3	CR
253-0151-00	Tape, PSA	4-2	CR
253-0152-00	Tape, PSA	4-3	CR
253-0153-00	Tape, PSA	4-3	CR
253-0154-00	Tape, PSA	4-3	CR
253-0155-00	Electrolytic Aluminum Foil	4-5	CR
253-0157-00	Tape, PSA	4-2	CR
253-0160-00	Tape, PSA	4-3	CR
253-0161-00	Tape, PSA	4-2	CR
253-0162-00	Tape, PSA	NP	
253-0164-00	Tape, PSA	4-4	CR
253-0165-00	Electrolytic Copper Foil	4-5	CR
253-0166-00	Electrolytic Copper Foil	4-5	CR
253-0171-00	Tape, PSA	4-3	CR
253-0173-00	Tape, PSA	NP	
253-0174-00	Tape, PSA	4-2	CR
253-0175-00	Tape, PSA	4-2	CR
253-0176-00	Tape, PSA	4-3	CR
253-0179-00	Tape, PSA	4-3	CR
253-0182-00	Tape, PSA	4-2	CR
253-0184-00	Tape, PSA	4-3	CR
253-0185-00	Tape, PSA	4-3	CR
253-0187-00	Tape, PSA	4-2	CS
253-0188-00	Tape, PSA	4-4	CS
253-0189-00	Tape, PSA	4-3	CR
253-0190-00	Tape, PSA	4-4	CR
253-0191-00	Tape, PSA	4-2	CR
253-0192-00	Tape, PSA	4-3	CR
253-0196-00	Tape, PSA	4-2	CR
253-0197-00	Tape, PSA	4-2	CR
253-0198-00	Tape, PSA	4-3	CR
253-0199-00	Tape, PSA	4-3	CR
253-0201-00	Tape, PSA	4-3	CR
253-0202-00	Tape, PSA	4-2	CR
253-0204-00	Tape, PSA	4-2	CR
253-0205-00	Tape, PSA	4-3	CR
253-0206-00	Tape, PSA	4-3	CR
253-0207-00	Tape, PSA	4-3	CR
253-0210-00	Tape, PSA	4-3	CR
253-0211-00	Tape, PSA	4-3	CR
253-0212-00	Tape, PSA	4-3	CR
253-0216-00	Tape, PSA	4-3	CR
253-0217-00	Tape, PSA	4-3	CR
253-0218-00	Tape, PSA	4-3	OT
253-0219-00	Tape, PSA	4-2	CR
253-0220-00	Electrolytic Copper Foil	4-5	CR
253-0221-00	Tape, PSA	4-2	CR
253-0224-00	Electrolytic Aluminum Foil	4-5	CS

PART NUMBER	DESCRIPTION	PAGE NO.	STATUS§§
253-0225-00	Electrolytic Aluminum Foil	4-5	CS
253-0226-00	Electrolytic Copper Foil	4-5	CR
253-0227-00	Tape, PSA	4-2	CR
253-0228-00	Tape, PSA	4-2	CS
253-0229-00	Tape, PSA	4-2	CR
253-0230-00	Tape, PSA	4-3	CR
253-0232-00	Tape, PSA	4-3	CR
253-0234-00	Tape, PSA	4-2	CR
253-0236-00	Tape, PSA	4-3	CR
253-0237-00	Tape, PSA	4-3	CR
253-0238-00	Tape, PSA	4-3	CR
253-0239-00	Tape, PSA	4-3	CR
253-0240-00	Tape, PSA	4-2	CR
253-0241-00	Tape, PSA	4-3	CR
253-0243-00	Tape, PSA	4-2	CR
253-0244-00	Electrolytic Copper Foil	4-5	CR
253-0245-00	Electrolytic Copper Foil	4-5	CR
253-0246-00	Tape, PSA	4-3	CR
253-0247-00	Electrolytic Copper Foil	4-5	CR
253-0248-00	Tape, PSA	4-3	CR
253-0249-00	Tape, PSA		OB
253-0251-00	Electrolytic Copper Foil	4-5	CR
253-0252-00	Tape, PSA	4-2	CR
253-0253-00	Tape, PSA	4-3	PP
253-0254-00	Tape, PSA	4-2	CR
253-0255-00	Tape, PSA	4-2	CR
253-0257-00	Electrolytic Copper Foil	4-5	CR
253-0259-00	Tape, PSA	4-3	CR
253-0261-00	Electrolytic Copper Foil		DL
253-0262-00	Electrolytic Copper Foil	4-5	CR
253-0263-00	Tape, PSA		DL
253-0264-00	Electrolytic Copper Foil	4-5	CR
253-0266-00	Electrolytic Copper Foil	4-5	CR
253-0268-00	Tape, PSA	4-3	CR
253-0269-00	Tape, PSA	4-3	CR
253-0270-00	Tape, PSA	4-4	CR
253-0272-00	Tape, PSA	4-4	CR
253-0273-00	Tape, PSA	4-4	CR
253-0274-00	Tape, PSA	4-2	CR
253-0276-00	Adhesives	4-6	PP
253-0277-00	Tape, PSA	4-4	PP
253-0279-00	Tape, PSA	4-2	PP
253-0280-00	Tape, PSA	4-3	CR
253-0281-00	Tape, PSA	4-2	CR
253-0282-00	Electrolytic Copper Foil	4-5	PP
253-0283-00	Tape, PSA	4-2	PP
253-0284-00	Tape, PSA	4-2	CR
253-0288-00	Electrolytic Copper Foil	4-5	CR
253-0289-00	Electrolytic Copper Foil	4-5	CR
253-0290-00	Electrolytic Copper Foil	4-5	CR
253-0291-00	Tape, PSA	4-2	CR
253-0292-00	Tape, PSA	4-2	CR
253-0293-00	Tape, PSA	4-3	CR
253-0294-00	Electrolytic Copper Foil	4-5	PP
253-0295-00	Electrolytic Copper Foil	4-5	CR
253-0296-00	Electrolytic Copper Foil	4-5	PP
253-0297-00	Tape, PSA	4-2	CR
253-0298-00	Tape, PSA	4-2	CR
253-0299-00	Tape, PSA	4-2	PP
253-0300-00	Electrolytic Copper Foil	4-5	CR
253-0301-00	Electrolytic Copper Foil	4-5	CR
253-0301-01	Electrolytic Copper Foil	4-5	PP
253-0302-00	Electrolytic Copper Foil	4-5	PP
253-0303-00	Tape, PSA	4-3	CR
253-0304-00	Tape, PSA	4-2	CR
255-0569-00	Tape, PSA	4-3	CR
255-0576-00	Tape, PSA	4-4	CS
255-0647-00	Tape, PSA	4-4	CR
256-0510-00	Ceramic Molding Material	4-8	CR
256-0513-00	Ceramic Molding Material	4-8	CR
256-0515-00	Ceramic Molding Material	4-8	CR
256-0517-00	Ceramic Molding Material	4-8	CR
256-0520-00	Ceramic Molding Material	4-8	CR
256-0523-00	Ceramic Molding Material	4-8	CR

CROSS REFERENCE INDEX

TAPE, PRESSURE SENSITIVE (ADHESIVE), ADHESIVES, GASSES AND CERAMIC MOLDING MATERIAL

PART NUMBER	DESCRIPTION	PAGE NO.	STATUS ^{§§}
256-0529-00	Ceramic Molding Material		NP
256-0530-00	Ceramic Molding Material	4-8	CR
256-0531-00	Ceramic Molding Material	4-8	CR
256-0532-00	Ceramic Molding Material	4-8	CR
256-0549-00	Ceramic Molding Material	4-8	CR
256-0551-00	Ceramic Molding Material	4-8	CR
256-0554-00	Ceramic Molding Material	4-8	CR
256-0555-00	Ceramic Molding Material		DL
256-0559-00	Ceramic Molding Material	4-8	CR
256-0564-00	Ceramic Molding Material		NP
256-0565-00	Ceramic Molding Material		DL
256-0569-00	Ceramic Molding Material	4-8	CR
256-0570-00	Dehydrating Agent	4-7	CR
256-0571-00	Ceramic Molding Material	4-8	CR
256-0584-00	Ceramic Molding Material	4-8	CR
256-0591-00	Ceramic Molding Material	4-8	OB
256-0592-00	Ceramic Molding Material		NP
256-0593-00	Ceramic Molding Material	4-8	CR
256-0604-00	Ceramic Molding Material	4-8	CR
256-0605-00	Ceramic Molding Material	4-8	CR
256-0606-00	Ceramic Molding Material	4-8	CR
256-0611-00	Ceramic Molding Material	4-8	CR
256-0612-00	Ceramic Molding Material		NP
256-0613-00	Ceramic Molding Material	4-8	CR
256-0614-00	Ceramic Molding Material	4-8	CR
256-0617-00	Ceramic Molding Material	4-8	CR
256-0618-00	Ceramic Molding Material	4-8	CR
256-0620-00	Ceramic Molding Material	4-8	CR
256-0630-00	Ceramic Molding Material	4-8	CR
256-0631-00	Ceramic Molding Material		DL
256-0634-00	Ceramic Molding Material	4-8	CR
256-0640-00	Adhesives	4-6	CR
256-0664-00	Adhesives	4-6	CR
256-0665-00	Adhesives	4-6	CR
256-0667-00	Ceramic Molding Material	4-8	CR
256-0678-00	Ceramic Molding Material	4-8	CR
256-0679-00	Ceramic Molding Material	4-8	CR
256-0680-00	Ceramic Molding Material	4-8	CR
256-0681-00	Ceramic Molding Material	4-8	CR
256-0683-00	Ceramic Molding Material		DL
256-0686-00	Ceramic Molding Material	4-8	CR
256-0688-00	Adhesives	4-6	CR
256-0693-00	Adhesives	4-6	CR
256-0694-00	Adhesives	4-6	CR
256-0696-00	Adhesives	4-6	PP
256-0697-00	Adhesives	4-6	PP
256-0698-00	Adhesives	4-6	PP
256-0700-00	Ceramic Molding Material	4-8	CR
256-0701-00	Adhesives	4-6	PP
256-0702-00	Adhesives	4-6	PP
348-0524-00	Tape, PSA	4-3	CR

§§ STATUS CODES

CR	Current Production
EN	Engineering
PP	Pre-Production
CS	Customer Service
NP	Non-Production
DL	Deleted
OB	Obsolete Instrument
CM	Custom Mod Instrument
DS	Digital Systems
OT	Obsolescent Instrument
MP	Modified Part
LR	Last Supply Current
LS	Last Supply Customer Service
VN	Vendor
TC	Tequipment Current Production
IN	International
SC	Sony/Tek Current Production

THE STATUS IN THIS CATALOG WAS CORRECT AT THE TIME IT WAS PUBLISHED, BUT IT IS SUBJECT TO CHANGE.

§ TO USE A PART WITH THIS STATUS ON A NEW INSTRUMENT REQUIRES THAT A NEW PURCHASED PART INITIATION FORM (PPIF) BE INITIATED.

(A GLOSSARY OF TERMS FOR THESE STATUS CODES CAN BE FOUND ON PAGE 0-10).

PAINT, COATINGS, SOLVENTS AND LUBRICANTS

SECTION 5

TABLE OF CONTENTS

	PAGE(S)
PAINTS	5-2
ADDITIVES	
THINNER	5-2
EPOXY RESIN	5-3
CATALYST	5-3
REDUCER	5-3
PRIMERS	5-3
LACQUERS	5-3
VARNISHES	5-3
SOLVENTS	5-4
SEALERS	5-5
PAINT REMOVERS	5-5
MARKING INKS	5-5
FINISHES, MISCELLANEOUS	5-5
COATINGS, INSULATIVE	5-6
COATINGS, CONDUCTIVE	5-6
COATINGS, RESISTIVE	5-6
COATINGS, PRECIOUS METAL	5-6
SILICONE GREASE	5-7
LUBRICANTS	5-7
UPDATES AND NOTES	5-8
CROSS REFERENCE INDEX	5-9 & 5-10

COST CODE

(CC COLUMN)

CODE	A	B	C	D	E	F	G	H	I	J	K	L	M	N	O
≈ VALUE with +	.75¢	2¢	3.75¢	6¢	10¢	18¢	35¢	60¢	\$1	\$2	\$3.75	\$6	\$10	\$18	\$35+
≈ VALUE no suffix	.5¢	1.5¢	3¢	5¢	8¢	15¢	25¢	50¢	75¢	\$1.50	\$3	\$5	\$8	\$15	\$25
≈ VALUE with -	.2¢	1.25¢	2.5¢	4.25¢	7¢	13¢	22¢	40¢	65¢	\$1.25	\$2.50	\$4.25	\$7	\$13	\$22

NOTE: Costs may vary from order to order due to order quantities, vendor, etc.

PAINTS

COLOR	TYPE AND REMARKS	MANUFACTURER & NUMBER	PART NUMBER	UNIT OF MEASURE	CC
Beige	Conductive, Silver Filled	Chomerics Type 4907	252-0247-00	Pound	O+
Beige	Acrylic, Electrostatic	Indusco #230	006-1791-00	Gallon	L+
Black	Vinyl, Satin, Baking	Fuller 870-T-1002	252-0229-00	Gallon	M+
	Vinyl, Satin, Baking, Aerosol Can	Fuller 870-T-1002	252-0229-01	Can	J+
	Vinyl, Enamel	Fuller #170-B-11	252-0064-00	Gallon	M+
Black	Optical Velvet	3M #101-C10	252-0124-00	Gallon	N
Black	Ultra Dull	Lilly 846-7000A	252-0236-00	Gallon	L+
Black, Carbide	Polyurethane	Sherwin Williams Polatex F63-B-12	252-0204-00	Gallon	N+
Blue	Vinyl, Spray	Fuller #170-K-22	252-0087-00	Quart	K-
Blue, Calculator	Vinyl	Fuller #870-K-1016	252-0235-00	Gallon	N-
Blue, Light	Vinyl, Enamel	Fuller #168-K-5	252-0063-00	Gallon	L
Blue, Tek	Vinyl, Electrostatic	Fuller #170-K-26	252-0062-00	Gallon	M+
Blue, Tek	Vinyl, Aerosol Can	Fuller #170-K-26	252-0092-02	Can	J+
Blue, #13NE	Enamel	Cont. Corp. of America	252-0180-00	Quart	K+
Brown, Earth	Vinyl, Baking	Fuller #870-J-1019	252-0229-03	Gallon	N-
Gold	Vinyl	Fuller #870-J-1010	252-0654-00	Gallon	O
Gray	Wrinkle	Fuller #89-H-925	252-0011-00	Gallon	M-
Gray	Latex	American Latex W-600	252-0095-00	Gallon	M
Gray	Enamel, Bakelite	Fuller #170-H-126	252-0052-00	Gallon	L
Gray	Polyurethane	Polane F99AX17	252-0250-00	Gallon	N-
Gray	Vinyl, Baking	Fuller #170-H-916	252-0188-00	Gallon	N
Gray		Cardinal Paint #5045-5209	252-0240-00	Gallon	N
Gray, Ivory	Vinyl, Baking	Fuller #870-H-1042	252-0229-05	Gallon	N
Gray, Light	Vinyl, Baking	Fuller #870-H-1012	252-0187-00	Gallon	M+
Gray, Light	Polyurethane	Polane F99AX16	252-0249-00	Gallon	O
Gray, Light	Enamel, Baking	Trail Chem 595 #26373	252-0159-00	Gallon	N-
Gray, Light		Fuller #870-H-1012	252-0187-03	Can	J+
Gray, Slate	Vinyl, Baking	Fuller #870-H-1041	252-0229-04	Gallon	N-
Gray, Trail	Vinyl, (MIL-E-15090B Class 2, Type 3)	Trail Chem #292505	252-0224-00	Gallon	M+
Gray, TV	Vinyl, Baking	Fuller #870-H-1017	252-0217-00	Gallon	M+
Gray, TV	Vinyl, Aerosol Can	Fuller #870-H-1017	252-0217-03	Can	J+
Gray, TV	Polyurethane	Sherwin Williams F99AX71	252-0263-00	Gallon	O
Gray, TV	Polyurethane	Sherwin Williams	252-0262-00	Gallon	O
Green	Enamel		252-0181-00	Quart	K+
Green	Vinyl, Baking	Fuller #870-G-1012	252-0653-00	Gallon	N-
Orange	Alkyd Resin	Trail Chemical 22203	252-0273-00	Gallon	O+
Red	Vinyl, Baking	Fuller #870-R-1005	252-0652-00	Gallon	O+
Red	Polyurethane	Polane F99RX5	252-0248-00	Gallon	N
Tan, Smoke	Polyurethane	Sherwin Williams F99-AX89	252-0264-01	Gallon	O
Tan, Smoke	Vinyl, Baking	Fuller #870-T-1017	252-0229-02	Gallon	N-
Tan, Tek	Polyurethane	Sherwin Williams F99-HX50	252-0264-00	Gallon	O
Tan, Tek	Vinyl Semigloss	Fuller #870-T-1001	252-0203-01	Gallon	M+
Tan, Tek	Vinyl, 13 oz. Aerosol Spray Can	Fuller #870-T-1001	252-0203-04	Can	J+
Tan, Tek Dark	Polyurethane	Sherwin Williams F99-AX-91	252-0264-03	Gallon	O
Tan, Tek Medium	Polyurethane	Sherwin Williams F99-AX90	252-0264-02	Gallon	O
White	Flat Enamel, Baking	Fuller #825-W-1025	252-0127-00	Gallon	M+
White	Alpha-Cryl (for use on plastics)	Rinished-Mason #A1199	252-0157-00	Gallon	O
White, Colonial	Amorthane	Armitage N-2068A	252-0268-00	Gallon	N
White, Linear	Polyurethane	Sherwin Williams, Polane T-F-63-W12	252-0723-00	Gallon	O-

ADDITIVES THINNERS

USAGE	MANUFACTURER & NUMBER	PART NUMBER	UNIT OF MEASURE	CC
Alpha-Cryl (252-0157-00)	Rinished-Mason #PNT-90	252-0158-00	Gallon	M-
Enamel	Fuller #75-C-11	252-0065-00	Gallon	L+
Enamel, DE-700 (006-0429-00)	Advance T-460	006-0432-00	Gallon	J+
Lacquer	Fuller #74-0212	006-0027-00	Gallon	K
Lacquer	Sherwin Williams #R7-K11	006-0695-00	Gallon	J+
Lacquer, Metal Etching Type		006-0098-00	Gallon	K-
Primer, Metal Etching Type	Fuller #132	252-0028-00	Gallon	L
Primer, Zinc Chromate	Fuller O'Brien #381-7	252-0716-00	Gallon	L+
Vinyl, Electrostatic (252-0062-00)	Fuller #175-C-37	252-0091-00	Gallon	L
VynaKote, Clear (252-0029-00)		252-0030-00	Bottle	J-

ADDITIVES (CONT)

EPOXY RESIN

COLOR	MANUFACTURER & NUMBER	PART NUMBER	UNIT OF MEASURE	CC
Beige, Satin	Fuller IE-218, AB-8	252-0259-00	Pound	L
Black	Fuller EF 734S0	252-0272-00	Pound	J+
Brown, Earth	Fuller	252-0259-02	Pound	L-
Gray, Ivory	Fuller EF-H-401-S-3	252-0259-04	Pound	L-
Gray, Slate	Fuller EF-H-407-T-3	252-0259-03	Pound	L
Tan, Smoke	Fuller EF-T-403-S1	252-0259-01	Pound	L
Tan, Tek	Reliance Powder Prod., Inc. 36209-45	252-0203-05	Pound	L-
	3M 235	252-0089-00	Pound	K
	3M 241	252-0077-00	Pound	K-

CATALYSTS

COLOR	MANUFACTURER & NUMBER	PART NUMBER	UNIT OF MEASURE	CC
	Hexcel Corp.	006-1215-01	Can	O+
	Emerson & Cuming	252-0258-00	Pound	L+
	Polane V66427	252-0251-00	Gallon	O+
	Westwood Ceramic Supply	006-1214-01	Each	O
	Shipley #9F	006-1821-00	Gallon	O+

REDUCERS

COLOR	MANUFACTURER & NUMBER	PART NUMBER	UNIT OF MEASURE	CC
	Polane R7K69	252-0252-00	Gallon	M+

PRIMERS

COLOR	TYPE & REMARKS	MANUFACTURER & NUMBER	PART NUMBER	UNIT OF MEASURE	CC
	Metal Etching	Dow Corning #1204	006-2475-00	Can	M+
	Chem-O-So1	Rust Magic	006-3449-00	Each	J+
	Rack-Coating	PK #4111	006-0353-00	Gallon	M
	Chemlock 607	Microsol C1452	006-1749-00	Gallon	M+
		Hughson Chemical	252-0116-00	Quart	M
Gray, Light	Silicone	Gertv SS-4155	006-2597-00	Pint	N-
Green	Metal Etching	Fuller #161141	252-0027-00	Gallon	M
Green	Chromate	Fuller 32127	006-3402-00	Gallon	N
	Rack Coating	Microsol E1315	006-1748-00	Gallon	N-
		Dow Corning #92-109	252-0215-00	Pint	O

LACQUERS

COLOR	REMARKS	MANUFACTURER & NUMBER	PART NUMBER	UNIT OF MEASURE	CC
Black	Spraying, Flat	Eoff Electric #1602	006-3453-00	Each	J+
Black	Spraying, Glossy	Eoff Electric #1601	006-3452-00	Each	J+
Blue		Fuller	252-0182-00	Gallon	M
Blue, Baby	Spraying	#1902	006-3459-00	Each	J+
Blue, Regal	Spraying	#1901	006-3458-00	Each	J+
Brass	Spraying	#2202	006-3464-00	Each	J+
Brown, Leather	Spraying	#2501	006-3467-00	Each	J+
Clear	Spraying	Fuller	006-0611-00	Gallon	M-
Clear	Spraying	Eoff Electric #1304	006-3446-00	Each	J+
Clear		Alpha-Cryl #827	252-0191-00	Gallon	M
Copper, Bright	Spraying	#2201	006-3463-00	Each	J+
Gold	Spraying	Eoff Electric #1701	006-3456-00	Each	J+
Gold, Tek	Spraying	#R-5171	006-2885-00	Gallon	N-
Gray, Machine	Spraying	Eoff Electric #1603	006-3454-00	Each	J+
Gray, Shadow	Spraying	Eoff Electric #1601	006-3455-00	Each	J+
Green, Hunter	Spraying	#2001	006-3461-00	Each	J+
Orange, Sunset	Spraying	#2401	006-3466-00	Each	J+
Red, Cherry	Spraying	#2101	006-3462-00	Each	J+
Silver	Spraying	#1401	006-3450-00	Each	J+
White	Spraying, Glossy	Eoff Electric #1501	006-3451-00	Each	J+
White, Antique	Spraying	#1503	006-3460-00	Each	J+
Yellow	Spraying	Eoff Electric #1801	006-3457-00	Each	J+
	Semigloss	Rasmussen #R-2111	006-2870-00	Gallon	M
	Acrylic	Insul-X A-11	252-0021-00	Gallon	N
	Aluminizing	E9802	439-0386-00	Gallon	L

VARNISHES

NAME/TYPE	REMARKS	MANUFACTURER & NUMBER	PART NUMBER	UNIT OF MEASURE	CC
Baking		Schenectady Isonel #31	252-0082-00	Gallon	M+
Silicone	Electrical	Dow Corning #997	252-0169-00	Pint	L-

SOLVENTS

NAME	REMARKS	MANUFACTURER AND NUMBER	PART NUMBER	UNIT OF MEASURE	CC
Acetate, Amyl	Purified	Amer. Scientific & Chemical	006-2783-00	Gallon	N+
Acetate, Butyl	Normal		006-0785-00	Gallon	K+
Acetate, Ethyl	Reagent, Anhydrous	Amer. Scientific & Chemical, MCBEX	006-3222-00	Gallon	O
Acetate, Ethyl			006-0502-00	Gallon	K
Acetone	Electronic Grade	Mallinckrodt #2441	006-3581-00	Gallon	M+
Acetone	CP		006-0500-00	Gallon	J+
Acetone	Electronic Grade	#14510	006-2548-00	Gallon	L-
Acetone	Electronic Grade	B & A 2750	006-0455-00	Pint	I+
Alcohol	Polyvinyl, Grade 51-05		252-0024-00	Pound	I+
Alcohol, Ethyl	Reagent, Denatured	American Scientific & Chem, MCBAX	006-3223-00	Gallon	N
Alcohol, Ethyl	Denatured		006-0553-00	Gallon	K-
Alcohol, Ethyl		3M, RM-59	006-3380-00	Bottle	L-
Alcohol, Isopropyl	Electronic Grade	#14513	006-2549-00	Gallon	L-
Alcohol, Isopropyl	Commercial		006-0034-00	Gallon	J+
Alcohol, Isopropyl	Electronic		006-1097-00	Gallon	M
Butyl Carbitol			006-0361-00	Gallon	L-
Butyl Cellosolve			006-0170-00	Gallon	K+
Butyl Compound	Black		252-0133-00	Pound	I+
Chevron Light			006-1165-00	Gallon	I
Chlorothene		Dow	006-2381-00	Gallon	L-
Dioxane	Reagent	Mallinckrodt #4937	006-0793-00	Gallon	O
Ethylene Dichloride	AR	Mallinckrodt #4966	006-1257-00	Bottle	N-
Ethylene Glycol	Reagent		006-1703-00	Gallon	N+
Fotocol	(See Alcohol, Ethyl)				
Freon			252-0047-00	Gallon	M+
Freon	3 ox. Aerosol		252-0120-00	Each	J-
Freon	Circuit Coolant (12 oz.)		006-0173-01	Can	J
Freon		TE 35	006-2056-00	Gallon	L
Freon, Te			006-1433-00	Gallon	M+
Freon, Tf	Degreaser (16 oz.)	MS-180	006-1926-00	Can	K-
Gasoline, White			006-0556-00	Gallon	J+
Genesolv "D"		B & S #2798	006-1832-00	Gallon	N
Kerosene			006-0597-00	Gallon	J+
Methanol	Reagent	Baker #9070	006-0009-00	Pint	I-
Methanol		#14515	006-2550-00	Gallon	L-
Methanol	Technical		006-0085-00	Gallon	J
Methylene Chloride			006-0616-00	Gallon	K+
Methyl-Ethyl Ketone			006-0690-00	Gallon	K
Methyl-Isobutyl Ketone		AR #6247	006-1928-00	Gallon	O
Perchloroethylene			006-0458-00	Gallon	K+
Perchloroethylene	Electronic Grade	Mallinckrodt #3123	006-3178-00	Gallon	M-
Silver Chloride		Mallinckrodt #2142	256-0673-00	Gram	H+
Socal #1			006-0696-00	Gallon	J+
Socal #2			006-0698-00	Gallon	J+
Standard Oil #325			006-0693-00	Gallon	J+
Toluene		Baker #9460	006-0613-00	Gallon	M-
Toluol			252-0008-00	Gallon	J+
Trichlorethylene			006-0750-00	Gallon	K
Trichlorethylene	Electronic		006-1037-00	Pint	J-
Xylene	Reagent	#2415	006-1161-00	Gallon	M-
Xyloil			252-0006-00	Gallon	J+

COST CODE

(CC COLUMN)

CODE	A	B	C	D	E	F	G	H	I	J	K	L	M	N	O
≈ VALUE with +	.75¢	2¢	3.75¢	6¢	10¢	18¢	35¢	60¢	\$1	\$2	\$3.75	\$6	\$10	\$18	\$35+
≈ VALUE no suffix	.5¢	1.5¢	3¢	5¢	8¢	15¢	25¢	50¢	75¢	\$1.50	\$3	\$5	\$8	\$15	\$25
≈ VALUE with -	.2¢	1.25¢	2.5¢	4.25¢	7¢	13¢	22¢	40¢	65¢	\$1.25	\$2.50	\$4.25	\$7	\$13	\$22

NOTE: Costs may vary from order to order due to order quantities, vendor, etc.

SEALERS

NAME	REMARKS	MANUFACTURER AND NUMBER	PART NUMBER	UNIT OF MEASURE	CC	
Loctite	With curing agent White (3 oz.)	AV #87-31	006-1595-00	Bottle	M	
Silastic		Dow Corning RTV	006-3141-00	Each	O+	
Silastic		Dow Corning, PTV #738	006-1923-00	Tube	K+	
Silicone		Clear Translucent	GE #SE-1201	006-0365-00	Each	K+
Silicone		White	GE-162	006-1171-03	Each	M-
Silicone	Gray (2 oz.)	GE RTV 616	006-2598-00	Each	N	
Silicone		Dow Corning RTV #1890	252-0150-00	Gallon	O+	
Silicone Rubber		Dow Corning RTV #3145	006-1171-00	Each	M+	
Silicone Rubber		Dow Corning RTV #3145	006-1171-01	Each	O	
Silicone Rubber		Clear	Dow Corning RTV #3144	006-2302-00	Tube	M
Silicone Rubber	Clear	Dow Corning RTV #3144	006-2302-01	Tube	O-	

PAINT REMOVERS

REMARKS	MANUFACTURER & NUMBER	PART NUMBER	UNIT OF MEASURE	CC
Stripper	American Scientific & Chemical	006-1242-00	Gallon	N
	RT-1	006-1965-00	Bottle	M+
	Waycoat CM	006-1912-00	Gallon	N-
	Dynachem	006-2564-00	Gallon	M+
	Jasco Speedomatic	006-2905-00	Gallon	M+
Stripper	Oakite EZ	006-2958-00	Gallon	M+
	Chemithon, Enstrip A	006-2993-00	Pound	K
	Chemithon, Enstrip NP #1	006-2994-00	Gallon	N-
	Chemithon, Enstrip NP #2	006-2995-00	Gallon	N
	EKC Chemica Corp., 712D	006-3198-00	Gallon	M+

MARKING INKS

COLOR	USE ON	MANUFACTURER & NUMBER	PART NUMBER	UNIT OF MEASURE	CC
Black	Thinner for Stanmark Etched Circuit Board Stamp Pad (1 oz.)	Stanmark #140-7-17	006-1002-00	Gallon	J+
		Lonco	006-1190-00	Gallon	O+
		Stanmark #192-9	002-0083-00	Bottle	I
			006-1029-00	Gallon	O-
			002-0077-00	Bottle	I
Black, India	Etched Circuit Board Etched Circuit Board Stamp Pad (1 oz.)	Wornowink Series M Ink & Catalyst	006-2612-00	Each	K-
		Lonco	006-1441-00	Gallon	O+
		Stanmark #192-8	002-0084-00	Bottle	I+
			006-1028-00	Gallon	O-
			006-1027-00	Gallon	O-
Blue	Vinyl Insulation, Wire Vinyl Insulation, Wire	Stanmark #192-2	006-1021-00	Gallon	O-
		Stanmark #192-6	006-1026-00	Gallon	O-
		Stanmark #192-4	006-1023-00	Gallon	O-
		Stanmark #192-5V	006-1025-00	Gallon	O-
		002-0086-00	Bottle	I	
Brown	Vinyl Insulation, Wire Etched Circuit Board Vinyl Insulation, Wire	Stanmark #192-5	006-1024-00	Gallon	O-
		Lonco	006-1189-00	Gallon	O
		Stanmark #192-1	006-1020-00	Gallon	O-
		Wornowink Series M Ink & Catalyst	006-2611-00	Each	K-
		Stanmark #192-3	006-1022-00	Gallon	O-
Gray	Vinyl Insulation, Wire	Stanmark #192-2	006-1021-00	Gallon	O-
Orange	Vinyl Insulation, Wire	Stanmark #192-4	006-1023-00	Gallon	O-
Red	Stamp Pad (1 oz.)	002-0086-00	Bottle	I	

FINISHES, MISCELLANEOUS

TYPE	MANUFACTURER & NUMBER	PART NUMBER	UNIT OF MEASURE	CC
Iridite #4P4 Iridite #14-2 Chromate conversion	Rodip CD-3	006-0006-00	Pound	L-
		006-0435-00	Pound	M+
		006-1618-00	Pound	J+

5

COATINGS INSULATIVE

COLOR	TYPE & REMARKS	MANUFACTURER & NUMBER	PART NUMBER	UNIT OF MEASURE	CC
Black Black	Implosion Liquid Silicone Corona Dope (2 oz.) Glyptal	Ruchothane CO-225 Dow Corning R-4-3117 GC #47-2 GE #1209	439-0313-00 252-0274-00 006-0541-00 252-0039-00	Pound Pound Bottle Gallon	J- N- I+ M+

CONDUCTIVE

COLOR	TYPE & REMARKS	MANUFACTURER & NUMBER	PART NUMBER	UNIT OF MEASURE	CC
Black	Nickel filled Static-bleed Static-bleed Extender	Acheson Electrodag #440 Acheson Electrodag #158 Acheson Electrodag A-7299	252-0269-00 252-0237-00 252-0238-00 439-0400-00	Gallon Gallon Gallon Gallon	O+ O+ L L+

RESISTIVE

	RESISTANCE (Ω/cm)	PART NUMBER	UNIT OF MEASURE	CC
	1	256-0684-00	Gram	K+
	10	256-0651-00	Gram	K-
	100	256-0597-00	Gram	J
	100	256-0652-00	Gram	K-
	1 k	256-0653-00	Gram	K-
	1 k	256-0598-00	Gram	J-
	10 k	256-0654-00	Gram	J+
	100 k	256-0655-00	Gram	J+
	100 k	256-0609-00	Gram	J-
	1 M	256-0656-00	Gram	K-

PRECIOUS METAL

METAL	TYPE & REMARKS	MANUFACTURER & NUMBER	PART NUMBER	UNIT OF MEASURE	CC
Gold	Conductive paste	Owens-Illinois 6985	256-0640-00	Gram	O-
Gold	Paste	LP50-2296	256-0615-00	Gram	N+
Gold	Paste	Dupont DP 9260	256-0659-00	Gram	O
Gold	Resin	Englehard A-2660	257-0077-00	Gram	K-
Platinum-Gold	Paste	Electro Science Labs #5835	256-0666-00	Gram	O-
Platinum-Gold	Paste	Dupont DP 8895	256-0649-00	Gram	N+
Paladium Silver	Conductive	Dupont DP 9061	256-0660-00	Gram	K-
Silver	Paint	Dynaloy 340	252-0165-00	Pint	O+
Silver	Paste (Scrn printable)	ESL 9990	256-0690-00	Gram	I
Silver	Paste	Dupont #6216	256-0579-00	Gram	J-
Silver	Paste	Dupont DP 4093	256-0689-00	Gram	L
Silver	Paste	Thick Film Systems #3345AG	256-0691-00	Gram	J+
Silver-Glass	Paste	Dupont #7886	256-0562-00	Gram	J
70% Silver Filled	Paint	Dupont #7713	252-0270-00	Gram	H+

5

SILICONE GREASE

DESCRIPTION	PART NUMBER	REMARKS	UNIT OF MEASURE	CC
Dow Corning #DC 4	006-0315-00	2.02 oz.	Each	L+
Dow Corning #DC 33	006-3272-00	5.30 oz.	Tube	M-
GE G305M	006-1353-00	2.00 oz.	Tube	M
GE G330M	006-2207-00	8.00 oz.	Tube	L+
GE G322L	006-2761-00		Tube	K-
Thermaloy #251	006-2525-00	1 lb. can	Can	N-
Thermaloy #249	006-2655-00		Tube	J+

LUBRICANTS

DESCRIPTION	REMARKS	PART NUMBER	UNIT OF MEASURE	CC
Becon 325	For Switch Lubrication	006-0219-00	Bottle	L
Becon 325 Grease	For Switch Lubrication	006-0147-00	Pound	J+
Dow Corning #200	Silicone; Dielectric Fluid	256-0534-00	Gallon	O
Dow Corning #5		006-4409-00	Tube	M-
Excelene	Polishing Oil	006-1103-00	Can	K-
Grease	Multipurpose	006-3684-00	Tube	J+
Lubriplate #14282	1/2 oz. tube	006-3167-00	Tube	I
Lubriplate A Type 105	5/16 oz. tube	006-0617-00	Tube	H-
Lubricant Stick "Door Ease"		006-0618-00	Each	I
Mobil #632		006-2531-00	Pound	H-
Mobil #45	For Transformers	256-0509-00	Gallon	J-
Rust-Lick EDM-30 Fluid		006-3157-00	Gallon	L
Silicone	Fluid/oil, 250	006-3492-00	Pint	O+
Union Marok #315 or Mobil		006-0013-00	Gallon	K
Vactra #2				
Union Marok #1000 or Mobil		006-1681-00	Gallon	K
Vactra #4				
Union Turbine Oil #150		006-2152-00	Gallon	K-
Union Turbine Oil #215		006-2118-00	Gallon	K
Union Turbine Oil #700		006-0011-00	Gallon	J-
WD-40		006-0145-00	Gallon	M+
WD-40 w/Hydrocarbon propellant		006-2574-00	Can	J
IBM #23 Grease	1/2 oz. tube	006-4536-00	Tube	F

5

COST CODE

(CC COLUMN)

CODE	A	B	C	D	E	F	G	H	I	J	K	L	M	N	O
≈ VALUE with +	.75¢	2¢	3.75¢	6¢	10¢	18¢	35¢	60¢	\$1	\$2	\$3.75	\$6	\$10	\$18	\$35+
≈ VALUE no suffix	.5¢	1.5¢	3¢	5¢	8¢	15¢	25¢	50¢	75¢	\$1.50	\$3	\$5	\$8	\$15	\$25
≈ VALUE with -	.2¢	1.25¢	2.5¢	4.25¢	7¢	13¢	22¢	40¢	65¢	\$1.25	\$2.50	\$4.25	\$7	\$13	\$22

NOTE: Costs may vary from order to order due to order quantities, vendor, etc.

UPDATES AND NOTES

5

§ STATUS CODES

CR	Current Production
EN	Engineering
PP	Pre-Production
CS	Customer Service
NP	Non-Production
DL	Deleted
OB	Obsolete Instrument
CM	Custom Mod Instrument
DS	Digital Systems
OT	Obsolescent Instrument
MP	Modified Part
LR	Last Supply Current
LS	Last Supply Customer Service
VN	Vendor
TC	Telequipment Current Production
IN	International
SC	Sony/Tek Current Production

THE STATUS IN THIS CATALOG WAS CORRECT AT THE TIME IT WAS PUBLISHED, BUT IT IS SUBJECT TO CHANGE.

§ TO USE A PART WITH THIS STATUS ON A NEW INSTRUMENT REQUIRES THAT A NEW PURCHASED PART INITIATION FORM (PPIF) BE INITIATED.

(A GLOSSARY OF TERMS FOR THESE STATUS CODES CAN BE FOUND ON PAGE 0-10).

COST CODE (CC COLUMN)

CODE	A	B	C	D	E	F	G	H	I	J	K	L	M	N	O
≈ VALUE with +	.75¢	2¢	3.75¢	6¢	10¢	18¢	35¢	60¢	\$1	\$2	\$3.75	\$6	\$10	\$18	\$35+
≈ VALUE no suffix	.5¢	1.5¢	3¢	5¢	8¢	15¢	25¢	50¢	75¢	\$1.50	\$3	\$5	\$8	\$15	\$25
≈ VALUE with -	.2¢	1.25¢	2.5¢	4.25¢	7¢	13¢	22¢	40¢	65¢	\$1.25	\$2.50	\$4.25	\$7	\$13	\$22

NOTE: Costs may vary from order to order due to order quantities, vendor, etc.

CROSS REFERENCE INDEX

PAINT, COATINGS, SOLVENTS AND LUBRICANTS

PART NUMBER	DESCRIPTION	PAGE NO.	STATUS§§	PART NUMBER	DESCRIPTION	PAGE NO.	STATUS§§
002-0077-00	Marking Ink	5-5	CR	006-1353-00	Silicone Grease	5-7	CR
002-0083-00	Marking Ink	5-5	CR	006-1433-00	Solvent	5-4	CR
002-0084-00	Marking Ink	5-5	CR	006-1437-00	Lubricant		DL
002-0086-00	Marking Ink	5-5	CR	006-1441-00	Marking Ink	5-5	CR
004-0001-00	Paint Remover		DL	006-1548-00	Lubricant		DL
006-0006-00	Finish, Miscellaneous	5-5	CR	006-1595-00	Sealer	5-5	CR
006-0009-00	Solvent	5-4	CR	006-1618-00	Finish, Miscellaneous	5-5	CR
006-0011-00	Lubricant	5-7	CR	006-1668-00	Lubricant		DL
006-0013-00	Lubricant	5-7	CR	006-1681-00	Lubricant	5-7	CR
006-0027-00	Thinner	5-2	CR	006-1703-00	Solvent	5-4	CR
006-0034-00	Solvent	5-4	CR	006-1748-00	Additive, Primer	5-3	CR
006-0085-00	Solvent	5-4	CR	006-1749-00	Additive, Primer	5-3	CR
006-0098-00	Thinner	5-2	CR	006-1791-00	Paint	5-2	CR
006-0145-00	Lubricant	5-7	CR	006-1821-00	Additive, Catalyst	5-3	CR
006-0147-00	Lubricant	5-7	CR	006-1825-00	Paint Remover		DL
006-0170-00	Solvent	5-4	CR	006-1832-00	Solvent	5-4	CR
006-0172-00	Lubricant		NP	006-1912-00	Paint Remover	5-5	CR
006-0173-01	Solvent	5-4	CR	006-1923-00	Sealer	5-5	CR
006-0219-00	Lubricant	5-7	CS	006-1926-00	Solvent	5-4	CR
006-0315-00	Silicone Grease	5-7	CR	006-1928-00	Solvent	5-4	CR
006-0353-00	Additive, Primer	5-3	CR	006-1965-00	Paint Remover	5-5	CR
006-0361-00	Solvent	5-4	CR	006-2056-00	Solvent	5-4	CR
006-0365-00	Sealer	5-5	CR	006-2118-00	Lubricant	5-7	CR
006-0432-00	Thinner	5-2	CR	006-2152-00	Lubricant	5-7	CR
006-0435-00	Finish, Miscellaneous	5-5	CR	006-2207-00	Silicone Grease	5-7	CR
006-0455-00	Solvent	5-4	CR	006-2302-00	Sealer	5-5	CR
006-0458-00	Solvent	5-4	CR	006-2302-01	Sealer	5-5	CR
006-0500-00	Solvent	5-4	CR	006-2381-00	Solvent	5-4	CR
006-0502-00	Solvent	5-4	CR	006-2475-00	Additive, Primer	5-3	CR
006-0541-00	Coating, Insulative	5-6	CR	006-2525-00	Silicone Grease	5-7	CR
006-0553-00	Solvent	5-4	CR	006-2531-00	Lubricant	5-7	CR
006-0556-00	Solvent	5-4	CR	006-2548-00	Solvent	5-4	CR
006-0597-00	Solvent	5-4	CR	006-2549-00	Solvent	5-4	CR
006-0607-00	Additive, Lacquer		NP	006-2550-00	Solvent	5-4	CR
006-0611-00	Additive, Lacquer	5-3	CR	006-2564-00	Paint Remover	5-5	CR
006-0613-00	Solvent	5-4	CR	006-2574-00	Lubricant	5-7	CR
006-0616-00	Solvent	5-4	CR	006-2597-00	Additive, Primer	5-3	CR
006-0617-00	Lubricant	5-7	CR	006-2598-00	Sealer	5-5	CR
006-0618-00	Lubricant	5-7	CR	006-2611-00	Marking Ink	5-5	CR
006-0642-00	Coating, Insulative		DL	006-2612-00	Marking Ink	5-5	CR
006-0690-00	Solvent	5-4	CR	006-2655-00	Silicone Grease	5-7	CR
006-0693-00	Solvent	5-4	CR	006-2761-00	Silicone Grease	5-7	CR
006-0695-00	Thinner	5-2	CR	006-2783-00	Solvent	5-4	CR
006-0696-00	Solvent	5-4	CR	006-2784-00	Solvent		DL
006-0698-00	Solvent	5-4	CR	006-2870-00	Additive, Lacquer	5-3	CR
006-0750-00	Solvent	5-4	CR	006-2885-00	Additive, Lacquer	5-3	CR
006-0785-00	Solvent	5-4	CR	006-2905-00	Paint Remover	5-5	CR
006-0793-00	Solvent	5-4	CR	006-2958-00	Paint Remover	5-5	CR
006-1002-00	Marking Ink	5-5	CR	006-2993-00	Paint Remover	5-5	CR
006-1020-00	Marking Ink	5-5	CR	006-2994-00	Paint Remover	5-5	CR
006-1021-00	Marking Ink	5-5	CR	006-2995-00	Paint Remover	5-5	CR
006-1022-00	Marking Ink	5-5	CR	006-3141-00	Sealer	5-5	CR
006-1023-00	Marking Ink	5-5	CR	006-3157-00	Lubricant	5-7	CR
006-1024-00	Marking Ink	5-5	CR	006-3158-00	Lubricant		DL
006-1025-00	Marking Ink	5-5	CR	006-3167-00	Lubricant	5-7	CR
006-1026-00	Marking Ink	5-5	CR	006-3178-00	Solvent	5-4	CR
006-1027-00	Marking Ink	5-5	CR	006-3198-00	Paint Remover	5-5	CR
006-1028-00	Marking Ink	5-5	CR	006-3222-00	Solvent	5-4	CR
006-1029-00	Marking Ink	5-5	CR	006-3223-00	Solvent	5-4	CR
006-1037-00	Solvent	5-4	CR	006-3272-00	Silicone Grease	5-7	CR
006-1097-00	Solvent	5-4	CR	006-3380-00	Solvent	5-4	CR
006-1103-00	Lubricant	5-7	CR	006-3402-00	Additive, Primer	5-3	CR
006-1161-00	Solvent	5-4	CR	006-3446-00	Additive, Lacquer	5-3	CR
006-1165-00	Solvent	5-4	CR	006-3449-00	Additive, Primer	5-3	CR
006-1171-00	Sealer	5-5	CR	006-3450-00	Additive, Lacquer	5-3	CR
006-1171-01	Sealer	5-5	CR	006-3451-00	Additive, Lacquer	5-3	CR
006-1171-02	Sealer		DL	006-3452-00	Additive, Lacquer	5-3	CR
006-1171-03	Sealer	5-5	CR	006-3453-00	Additive, Lacquer	5-3	CR
006-1189-00	Marking Ink	5-5	CR	006-3454-00	Additive, Lacquer	5-3	CR
006-1190-00	Marking Ink	5-5	CR	006-3455-00	Additive, Lacquer	5-3	CR
006-1214-01	Additive, Catalyst	5-3	CR	006-3456-00	Additive, Lacquer	5-3	CR
006-1215-01	Additive, Catalyst	5-3	CR	006-3457-00	Additive, Lacquer	5-3	CR
006-1223-00	Finish, Miscellaneous		DL	006-3458-00	Additive, Lacquer	5-3	CR
006-1242-00	Paint Remover	5-5	CR	006-3459-00	Additive, Lacquer	5-3	CR
006-1257-00	Solvent	5-4	CR	006-3460-00	Additive, Lacquer	5-3	CR

CROSS REFERENCE INDEX (CONT)

PAINT, COATINGS, SOLVENTS AND LUBRICANTS (CONT)

PART NUMBER	DESCRIPTION	PAGE NO.	STATUS§§
006-3461-00	Additive, Lacquer	5-3	CR
006-3462-00	Additive, Lacquer	5-3	CR
006-3463-00	Additive, Lacquer	5-3	CR
006-3464-00	Additive, Lacquer	5-3	CR
006-3466-00	Additive, Lacquer	5-3	CR
006-3467-00	Additive, Lacquer	5-3	CR
006-3492-00	Lubricant	5-7	CR
006-3581-00	Solvent	5-4	CR
006-3684-00	Lubricant	5-7	CR
006-4409-00	Lubricant	5-7	CR
006-4536-00	Lubricant	5-7	CR
252-0006-00	Solvent	5-4	CR
252-0008-00	Solvent	5-4	CR
252-0011-00	Paint	5-2	CS
252-0021-00	Additive, Lacquer	5-3	CR
252-0022-00	Paint		OB
252-0024-00	Solvent	5-4	CR
252-0026-00	Additive, Primer		NP
252-0027-00	Additive, Primer	5-3	CR
252-0028-00	Thinner	5-2	CR
252-0030-00	Thinner	5-2	CR
252-0031-00	Paint		DL
252-0039-00	Coating, Insulative	5-6	CR
252-0047-00	Solvent	5-4	CR
252-0052-00	Paint	5-2	CR
252-0062-00	Paint	5-2	CR
252-0063-00	Paint	5-2	CR
252-0064-00	Paint	5-2	CR
252-0065-00	Thinner	5-2	CR
252-0077-00	Additive, Epoxy Resin	5-3	CR
252-0082-00	Additive, Varnish	5-3	CR
252-0087-00	Paint	5-2	CS
252-0089-00	Additive, Epoxy Resin	5-3	CR
252-0091-00	Thinner	5-2	CR
252-0092-00	Additive, Lacquer		DL
252-0092-01	Additive, Lacquer		DL
252-0092-02	Paint	5-2	CS
252-0095-00	Paint	5-2	CR
252-0116-00	Additive, Primer	5-3	CR
252-0120-00	Solvent	5-4	CR
252-0123-00	Paint		NP
252-0124-00	Paint	5-2	CS
252-0125-00	Additive, Primer		NP
252-0127-00	Paint	5-2	CR
252-0133-00	Solvent	5-4	CS
252-0150-00	Sealer	5-5	CR
252-0157-00	Paint	5-2	CR
252-0158-00	Thinner	5-2	CR
252-0159-00	Paint	5-2	CS
252-0165-00	Coating, Precious Metal	5-6	CR
252-0169-00	Additive, Varnish	5-3	CR
252-0175-00	Paint		OT
252-0180-00	Paint	5-2	CS
252-0181-00	Paint	5-2	CS
252-0182-00	Additive, Lacquer	5-3	CR
252-0187-00	Paint	5-2	CR
252-0187-01	Paint		DL
252-0187-02	Paint		DL
252-0187-03	Paint	5-2	CS
252-0188-00	Paint	5-2	CR
252-0191-00	Additive, Lacquer	5-3	CR
252-0203-00	Paint		LS
252-0203-01	Paint	5-2	CR
252-0203-02	Paint		DL
252-0203-03	Paint		DL
252-0203-04	Paint	5-2	CR
252-0203-05	Additive, Epoxy Resin	5-3	CR
252-0204-00	Paint	5-2	CR
252-0215-00	Additive, Primer	5-3	CR
252-0217-00	Paint	5-2	CR
252-0217-01	Paint		DL
252-0217-02	Paint		DL
252-0217-03	Paint	5-2	CR
252-0224-00	Paint	5-2	CR
252-0229-00	Paint	5-2	CR

PART NUMBER	DESCRIPTION	PAGE NO.	STATUS§§
252-0229-01	Paint	5-2	CR
252-0229-02	Paint	5-2	CR
252-0229-03	Paint	5-2	CR
252-0229-04	Paint	5-2	CR
252-0229-05	Paint	5-2	CR
252-0235-00	Paint	5-2	CS
252-0235-01	Paint		DL
252-0236-00	Paint	5-2	CR
252-0237-00	Coating, Conductive	5-6	CR
252-0238-00	Coating, Conductive	5-6	CR
252-0240-00	Paint	5-2	CR
252-0247-00	Paint	5-2	CR
252-0248-00	Paint	5-2	CR
252-0249-00	Paint	5-2	CR
252-0250-00	Paint	5-2	CR
252-0251-00	Additive, Catalyst	5-3	CR
252-0252-00	Additive, Reducer	5-3	CR
252-0258-00	Additive, Catalyst	5-3	CR
252-0259-00	Additive, Epoxy Resin	5-3	CR
252-0259-01	Additive, Epoxy Resin	5-3	CR
252-0259-02	Additive, Epoxy Resin	5-3	CR
252-0259-03	Additive, Epoxy Resin	5-3	CR
252-0259-04	Additive, Epoxy Resin	5-3	CR
252-0260-00	Paint		DL
252-0262-00	Paint	5-2	CR
252-0263-00	Paint	5-2	PP
252-0264-00	Paint	5-2	PP
252-0264-01	Paint	5-2	CR
252-0264-02	Paint	5-2	CR
252-0264-03	Paint	5-2	CR
252-0268-00	Paint	5-2	CM
252-0269-00	Coating, Conductive	5-6	CR
252-0270-00	Coating, Precious Metal	5-6	CR
252-0271-00	Additive, Epoxy Resin		DL
252-0272-00	Additive, Epoxy Resin	5-3	PP
252-0273-00	Paint	5-2	CS
252-0274-00	Coating, Insulative	5-6	CR
252-0652-00	Paint	5-2	CR
252-0653-00	Paint	5-2	CR
252-0654-00	Paint	5-2	CR
252-0656-00	Paint	5-6	CR
252-0716-00	Paint	5-2	CR
252-0723-00	Paint	5-2	CM
256-0509-00	Lubricant	5-7	CS
256-0534-00	Lubricant	5-7	CR
256-0562-00	Coating, Precious Metal	5-6	CR
256-0579-00	Coating, Precious Metal	5-6	CR
256-0597-00	Coating, Resistive	5-6	CR
256-0598-00	Coating, Resistive	5-6	CS
256-0609-00	Coating, Resistive	5-6	CS
256-0615-00	Coating, Precious Metal	5-6	CR
256-0619-00	Coating, Resistive	5-6	OB
256-0632-00	Coating, Precious Metal		NP
256-0640-00	Coating, Precious Metal	5-6	CR
256-0646-00	Coating, Resistive		DL
256-0649-00	Coating, Precious Metal	5-6	CR
256-0651-00	Coating, Resistive	5-6	CR
256-0652-00	Coating, Resistive	5-6	CR
256-0653-00	Coating, Resistive	5-6	CR
256-0654-00	Coating, Resistive	5-6	CR
256-0655-00	Coating, Resistive	5-6	CR
256-0656-00	Coating, Resistive	5-6	CR
256-0659-00	Coating, Precious Metal	5-6	CR
256-0660-00	Coating, Precious Metal	5-6	CR
256-0666-00	Coating, Precious Metal	5-6	CR
256-0673-00	Solvent	5-4	CR
256-0676-00	Coating, Resistive		NP
256-0677-00	Coating, Resistive		NP
256-0684-00	Coating, Resistive	5-6	CR
256-0689-00	Coating, Precious Metal	5-6	CR
256-0690-00	Coating, Precious Metal	5-6	CR
256-0691-00	Coating, Precious Metal	5-6	CR
257-0077-00	Coating, Precious Metal	5-6	CR
439-0313-00	Coating, Insulative	5-6	CR
439-0386-00	Additive, Lacquer	5-3	CR
439-0400-00	Coating, Conductive	5-6	CR

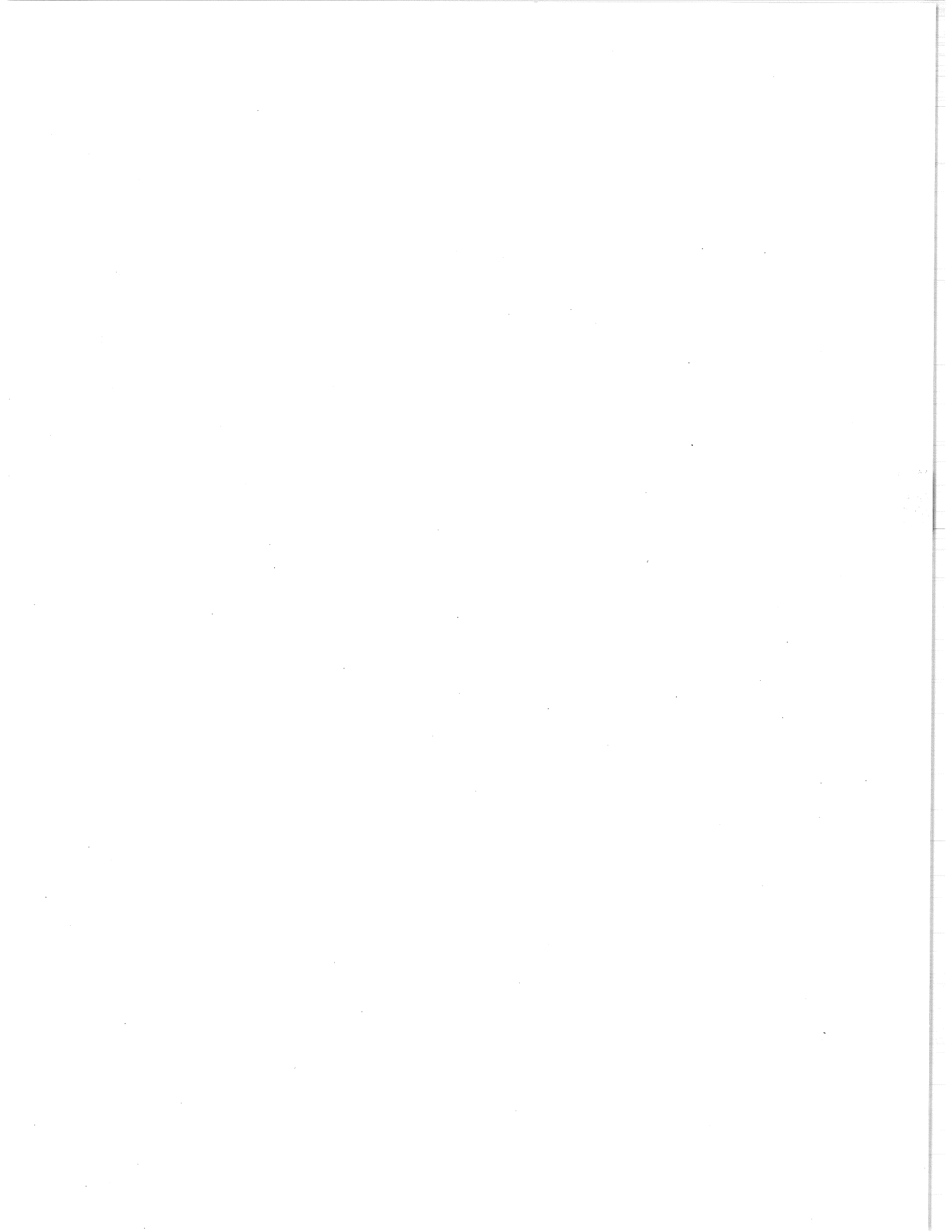

ALUMINUM EXTRUSION

FINISHES

FINISHES: THE FOLLOWING CHART LISTS THE TEK STANDARD "F" FINISHES WITH THE APPROPRIATE INDUSTRY TERMINOLOGY, AND THEIR APPROPRIATE END APPLICATION IN TERMS OF TEK GRADE FINISHES.

<u>TEK STANDARD</u>	<u>DESCRIPTION</u>	<u>INDUSTRY STANDARD</u>	<u>END APPLICATION</u>
F-0	NO SIGNIFICANT CHANGE	MILL FINISH	TEK GRADE IV, III
F-1	EXPOSED SURFACES APPEARANCE IS NOT IMPORTANT, 135 MICROFINISH (150 RMS)	EXPOSED SURFACE	TEK GRADE III, II
F-2	SURFACE APPEARANCE IS IMPORTANT, 90 MICROFINISH (100 RMS)	SPECIAL #1	TEK GRADE II
F-3	SURFACE APPEARANCE IS CRITICAL, 55 MICROFINISH (60 RMS)	SPECIAL #2	TEK GRADE I

AN F-0 EXTRUSION WILL NORMALLY MEET GRADE IV NEEDS AND REQUIRE SOME SECONDARY FINISHING TO MEET GRADE III REQUIREMENTS, AND F-1 WILL USUALLY BE SATISFACTORY FOR GRADE III, BUT REQUIRE SECONDARY FINISHING TO MEET GRADE II. F-3 FINISHES CAN ONLY BE USED BY SPECIAL AGREEMENT WITH THE SUPPLIER, AND ARE PRIMARILY FOR SECTIONS THAT CANNOT BE READILY FINISHED WITH SECONDARY OPERATIONS, AND THAT HAVE A GRADE I COSMETIC REQUIREMENT.

TOLERANCES: OBVIOUSLY, SOME TOLERANCES NEED TO BE CLOSER THAN INDUSTRY STANDARDS. IT IS TRUE THAT SOME DIMENSIONS CAN BE HELD CLOSER, PARTICULARLY THROUGH SOLID METAL: HOWEVER, THIS AFFECTS DIE LIFE DUE TO THE NORMAL EROSION WEAR THAT TAKES PLACE IN AN EXTRUSION DIE. CLOSER TOLERANCES BETWEEN WEBS ARE DIFFICULT BECAUSE OF THE SHRINKAGE AND STRESS RELIEF CHARACTERISTICS OF ALUMINUM EXTRUSIONS, SO THESE SHOULD BE HANDLED BY SECONDARY OPERATIONS OR ALTERNATE DESIGN METHODS. A THOROUGH ACQUAINTANCE WITH TABLE 2 ON PAGE 13 OF THE TEK STANDARD WILL BE MOST HELPFUL IN MEETING THE DESIGN ENGINEER'S REQUIREMENTS, WHILE BEING CONSISTENT WITH THE PROCESS RESTRICTIONS OF THE EXTRUSION INDUSTRY.

STRESS RELIEF DISTORTIONS: BECAUSE OF THE NATURE OF THE EXTRUSION PROCESS, ALUMINUM EXTRUSIONS HAVE MANY CONTAINED INTERNAL STRESSES. WHENEVER THEY ARE CUT OR MACHINED, THEY MAY DISTORT TO AN OUT-OF-TOLERANCE CONDITION, DEPENDING UPON THE CUT AND THE CONFIGURATION OF THE PART BEING MADE. CHANNEL OR ANGLE CONFIGURATIONS ARE PARTICULARLY SUSCEPTIBLE TO THIS, AND WILL BE SIGNIFICANTLY DISTORTED BY JUST CUTTING TO LENGTH. CONSULTATION WITH PRODUCTION ENGINEERING IS RECOMMENDED IN THE EARLY DESIGN STAGE TO ALLOW FOR APPROPRIATE FINISHING MATERIAL IN EXTRUSION DESIGNS WHERE DISTORTION MAY BE CRITICAL.

VENDOR'S DRAWING: THE VENDOR'S EXTRUSION PROCESS REQUIRES THAT HE DESIGN A DIE THAT WILL ALLOW FOR SHRINKAGE, DIE WEAR, AND THE STRESS RELIEF CHARACTERISTICS OF EXTRUDED ALUMINUM WHEN CUT. THIS DIE IS ESSENTIALLY A FEMALE OF THE DESIRED EXTRUSION, WITH THESE ALLOWANCES DESIGNED IN. BECAUSE OF THESE REQUIREMENTS, THE VENDOR'S DRAWING IS SELDOM AN EXACT DUPLICATE OF THE TEK DESIGNER'S DRAWING. RATHER, IT IS A DRAWING OF WHAT THE VENDOR BELIEVES HE CAN DO TO MEET THE DESIGNER'S NEEDS, AND YET ALLOW FOR THE PROCESS VARIABLES. CHARACTERISTICALLY, THIS DRAWING WILL BE TOLERANCED ACCORDING TO THE APPROPRIATE TABLES IN THE TEK STANDARD, WHICH ARE IDENTICAL TO THE ALUMINUM ASSOCIATION TABLES.

TEK DRAWINGS, TEK STANDARD: THE NEW STANDARD FOR EXTRUSIONS, 062-1713-00, INCORPORATES IN ITS ENTIRETY THE ALUMINUM ASSOCIATION STANDARDS, WITH NOTES ON THEIR USE. THIS REPLACES ALL EARLIER STANDARDS, AND SHOULD BE CAREFULLY USED IN THE DESIGN OF NEW EXTRUSIONS TO AVOID PROBLEMS WITH FINISHES AND TOLERANCES (ANGULAR AS WELL AS LINEAR).

IN THE EVENT OF QUESTIONS ON ANY OF THE AREAS DISCUSSED ABOVE, PRODUCTION ENGINEERING WILL BE GLAD TO WORK WITH EXTRUSION SUPPLIERS AND DESIGN ENGINEERING TO MEET OUR INSTRUMENT NEEDS.

COST CODE (CC COLUMN)

CODE	A	B	C	D	E	F	G	H	I	J	K	L	M	N	O
≈ VALUE with +	.75¢	2¢	3.75¢	6¢	10¢	18¢	35¢	60¢	\$1	\$2	\$3.75	\$6	\$10	\$18	\$35+
≈ VALUE no suffix	.5¢	1.5¢	3¢	5¢	8¢	15¢	25¢	50¢	75¢	\$1.50	\$3	\$5	\$8	\$15	\$25
≈ VALUE with -	.2¢	1.25¢	2.5¢	4.25¢	7¢	13¢	22¢	40¢	65¢	\$1.25	\$2.50	\$4.25	\$7	\$13	\$22

NOTE: Costs may vary from order to order due to order quantities, vendor, etc.

ALUMINUM EXTRUSION

SECTION 6

TABLE OF CONTENTS

	PAGE(S)
FINISHES	6-0
CHANNEL	6-2
ANGLE	6-2
MISCELLANEOUS	6-3 THRU 6-36
MODULAR PACKAGING EXTRUSIONS	6-37 & 6-38
CROSS REFERENCE INDEX	6-39 THRU 6-41
NOTES	6-42
MECHANICAL PROPERTIES (PER ASTM B221)	6-43
INDEX TO TABLES OF PERMISSIBLE VARIATIONS	6-43
TOLERANCES	6-44 THRU 6-48

REFERENCES

STANDARD SPECIFICATION FOR ALUMINUM-ALLOY EXTRUDED BARS, RODS, SHAPES, AND TUBES -- ASTM DESIGNATION: B221
 DIMENSIONAL TOLERANCES FOR ALL ALUMINUM MILL PRODUCTS -- ANSI H35.2

OUTLINE DRAWINGS

THESE ARE FOR REFERENCE PURPOSES ONLY. WHEN YOU ARE CONSIDERING USING AN EXTRUSION, USE THESE DRAWINGS TO SEE IF WE HAVE AN EXTRUSION IN STOCK WHICH COULD BE USED. IF THE OUTLINE DRAWING SHOWS POSSIBILITIES FOR YOUR USE, GET A COMPLETELY DIMENSIONED DRAWING FROM THE MICROFILM FILE FOR FURTHER INFORMATION.

TEK STANDARDS PERTAINING TO MATERIALS

062-1702-00	Welding, Soldering & Brazing	D-100	Die Casting & Molding Standards
062-1703-00	Finishes, Glossary of Terms		
062-1713-00	Drafting, Aluminum Extrusions	H Series	Tooling Standards
062-1718-00	Finish Quality, Cosmetic		
062-2845-00	Mechanically Applied Finishes	062-5818-01	Aluminum (M150)
062-2848-00	Bend Allowance & Deduction	M-200	Brass
062-2850-00	Finish, Surface Texture	M-250	Copper
062-2854-00	Finishes, Chemical & Electromechanical	M-300	Copper-Beryllium
062-2856-00	Non-Additive Finishes for Brass, Copper & Copper Alloys	M-350	Beryllium-Nickel
062-2860-00	Finishes, Anodized	M-400	Phosphor-Bronze
062-2863-00	Zinc Die Cast Finishes, Chromate Conversion Coatings	M-450	Steel
062-2868-00	Finish, Etch Chromate & Lacquer (On Aluminum)	M-500	Stainless Steel
062-2868-01	Chromate Conversion Coating for Al Die Casting Alloy 3431	M-550	Magnetic Shielding Materials (Iron-Nickel & Nickel-Silver)
062-2871-00	Finish, Passivating	M-600	Copper-Nickel-Zinc
062-5818-00	General Information about Bulk Raw Materials		

* ALUMINUM EXTRUSION (CONT)

ANGLES

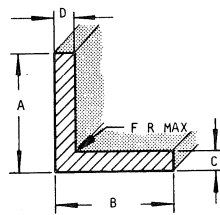

FIG A

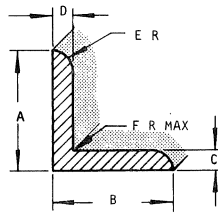

FIG B

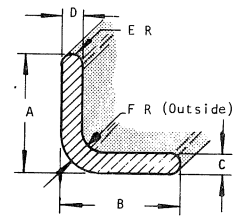
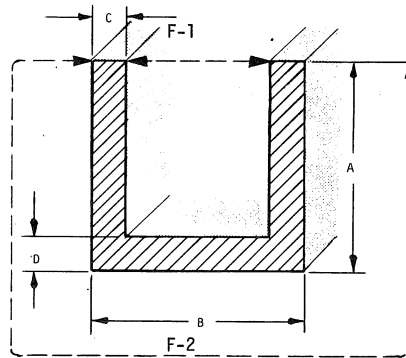

FIG C

A	B	C	D	E	F	ALLOY & TEMPER *	FIGURE	PART NUMBER	CC
.130	.750	.067	.125			6063-T5	A	251-0242-00	1b J-
.500	.500	.125	.125			6063-T5	A	251-1172-00	1b J
.375	.375	.125	.125			6063-T5	A	251-1292-00	1b J
.375	1.250	.125	.125			6063-T6	A	251-0144-00	1b J-
.450	1.000	.100	.250		.015	6063-T6	A	251-1675-00	1b J-
.750	.750	.063	.063			6063-T52	A	251-1298-00	1b J-
.750	.750	.125	.125	.125	.094	6063-T6	B	251-0002-00	1b J
.750	.750	.150	.150	.016	.218	6063-T6	C	251-1008-00	1b J+
.875	.875	.125	.125		.094	6063-T6	A	251-0191-00	1b J+
.875	.875	.094	.094	.047	.375	6063-T6	C	251-0069-00	1b J+
1.000	1.000	.062	.062		.015	6063-T5	A	251-0049-00	1b J-
1.000	1.350	.312	.312		.031	6063-T5	A	251-0245-00	1b H
1.100	.650	.250	.150		.031	6063-T6	A	251-1054-00	1b J+
1.250	.800	.560	.225		.125	6063-T6	A	251-1181-00	1b I+
1.250	1.500	.188	.188	.125	.188	6061-T6	B	251-0205-00	ft I+
1.250	1.250	.125	.125		.015	6063-T5	A	251-0119-00	1b J-
1.361	.750	.187	.080		.062	6063-T6	A	251-1681-00	1b K
2.000	2.000	.250	.250	.125	.250	6063-T6	B	251-1020-00	1b J-
2.700	1.000	.165	.165		.030	6063-T5	A	251-1698-00	1b K-

CHANNELS

** F-1 & F-2 FINISH AS SHOWN,
OTHERS F-0 ALL OVER.



A	B	C	D	ALLOY & TEMPER *	PART NUMBER	CC
.150	.337	.047	.050	6063-T6	251-1495-00	1b J+
.188	.875	.156	.126	6063-T6	251-1633-00	1b J-
.375	.500	.125	.125	6063-T5	251-0126-00	1b J-
.500	1.000	.125	.125	6063-T52	251-1703-00	1b J-
.710	1.615	.375	.210	6063-T6	** 251-1609-00	1b J+
.938	1.250	.150	.136	6063-T6	251-0226-00	1b J+
.950	1.550	.125	.125	6063-T6	251-1129-00	1b J
1.082	1.614	.250	.182	6063-T6	251-1049-00	1b K+
1.250	1.250	.125	.125	6063-T5	251-0004-00	1b J-
1.312	7.055	.315	.188	6063-T6	** 251-0251-00	1b J+
1.312	5.308	.231	.190	6063-T6	251-1003-00	1b J-
1.500	2.500	.125	.125	6061-T6	251-1312-00	1b J+
8.805	1.312	.312	.312	6063-T6	** 251-1637-00	1b J+

* FOR MECHANICAL PROPERTIES & TOLERANCES, SEE PAGES 6-43 THRU 6-48.

* ALUMINUM EXTRUSION (CONT)

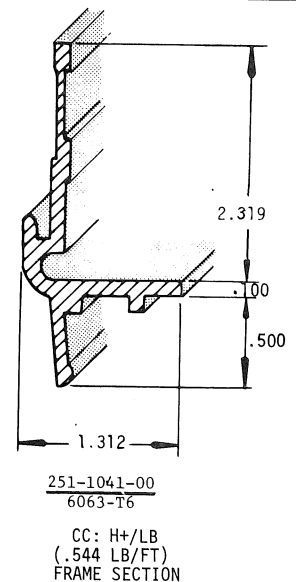
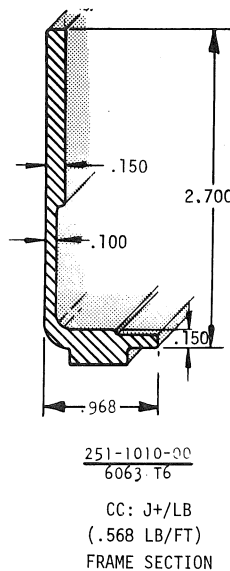
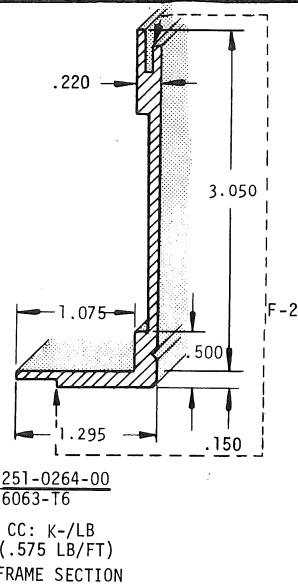
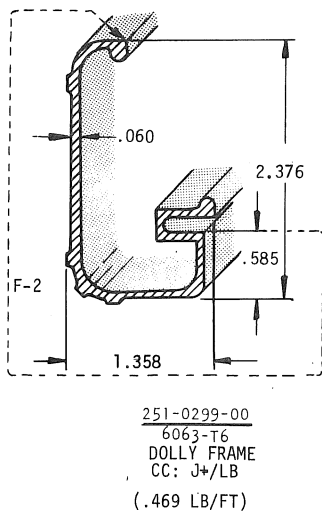
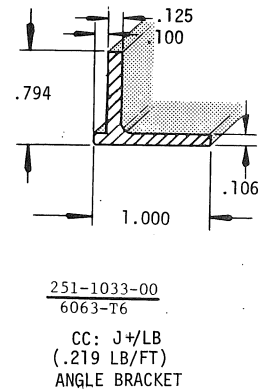
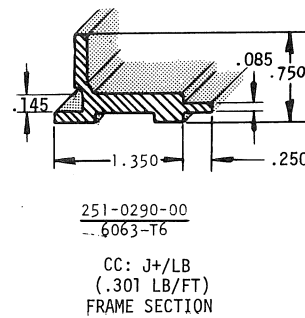
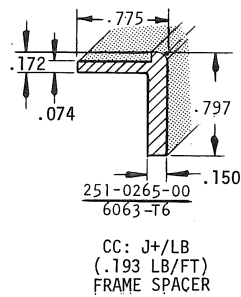
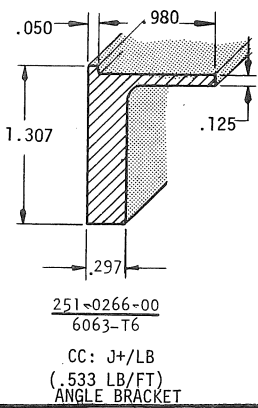
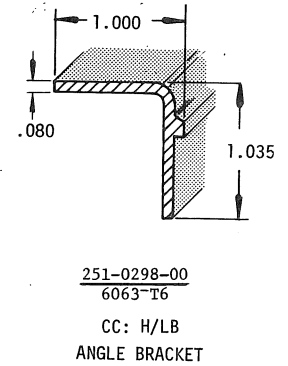
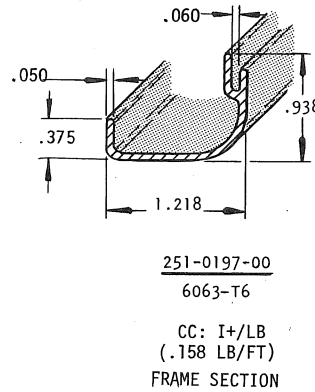
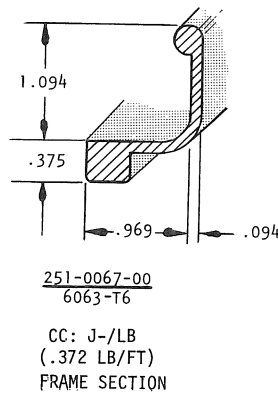
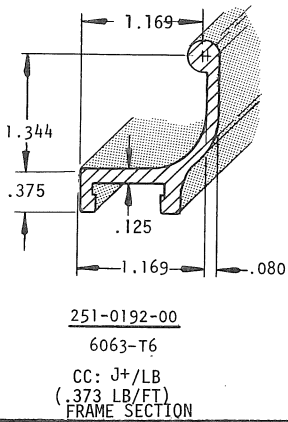
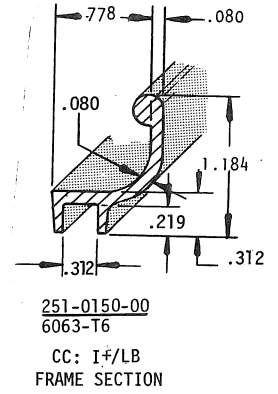
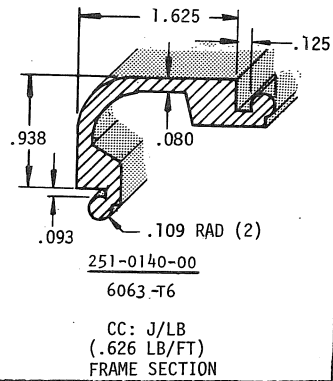
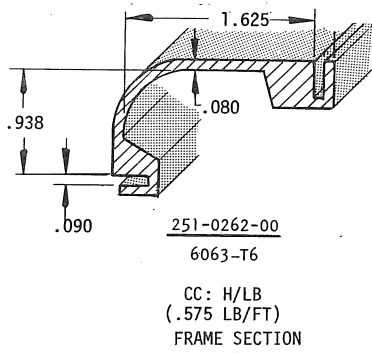
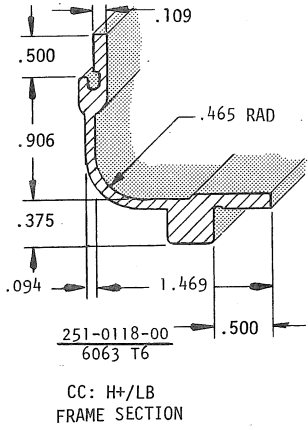

* ALUMINUM EXTRUSION (CONT)

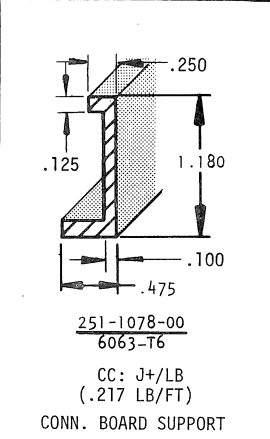
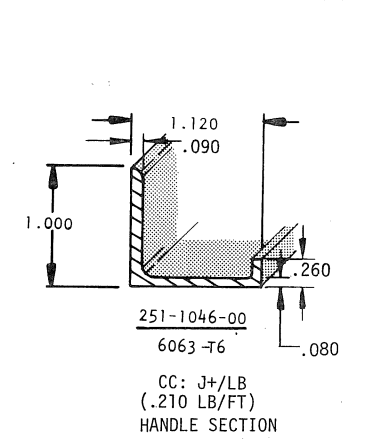
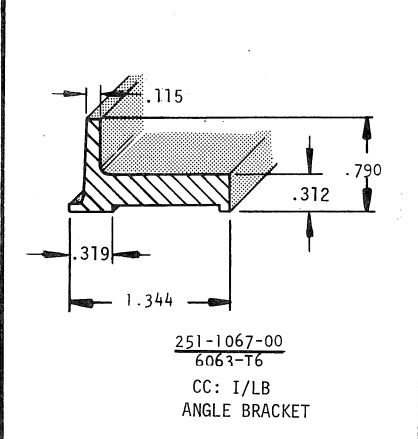
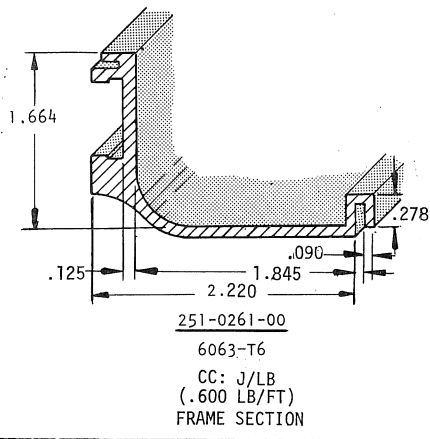

6

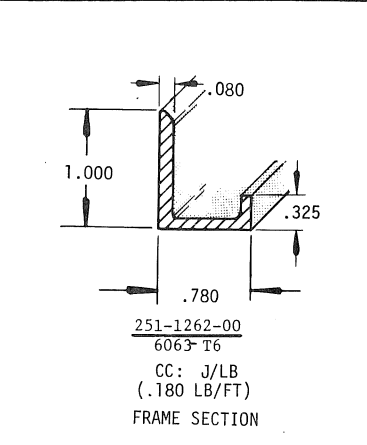
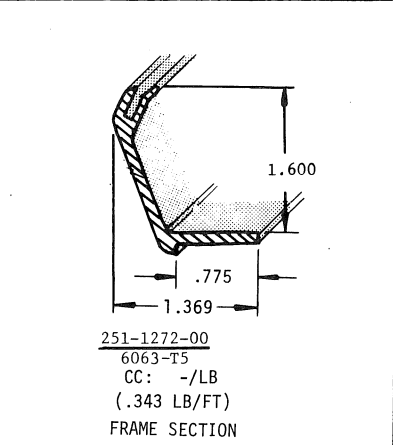
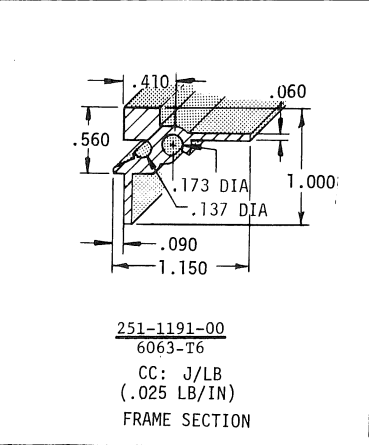
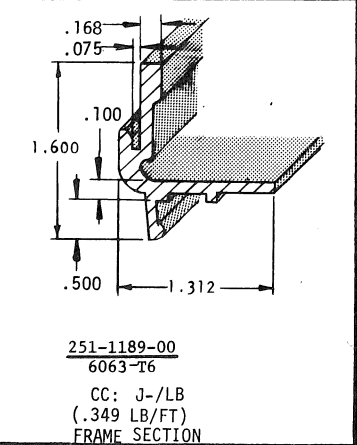
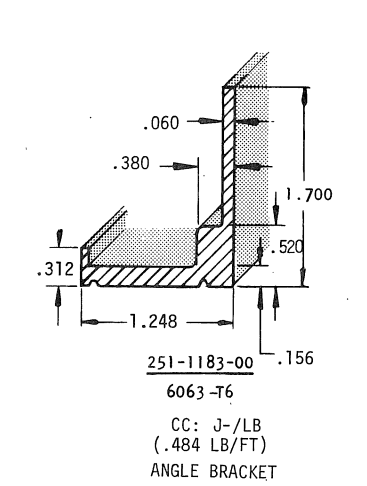
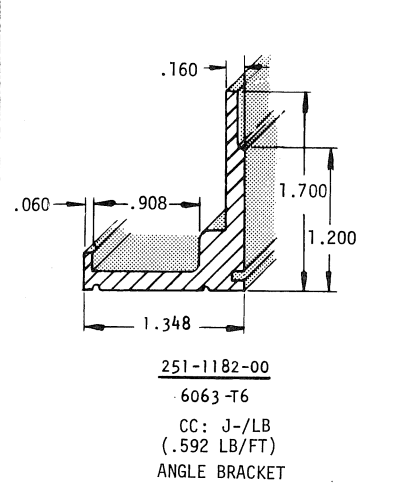
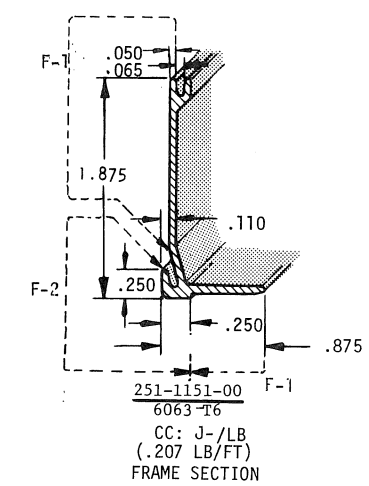
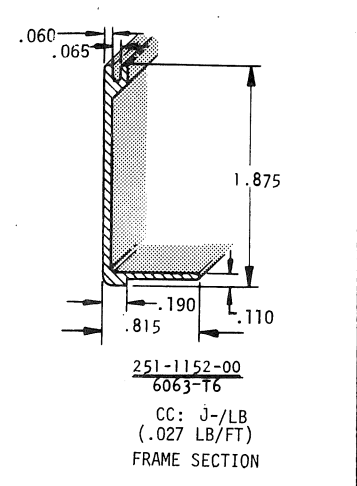
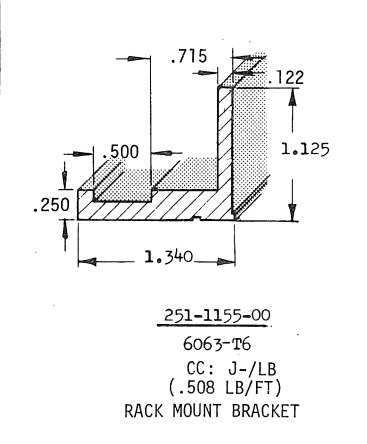
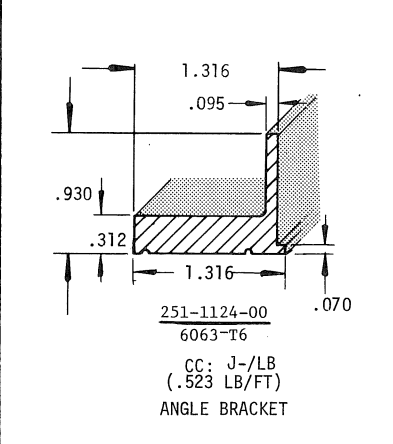
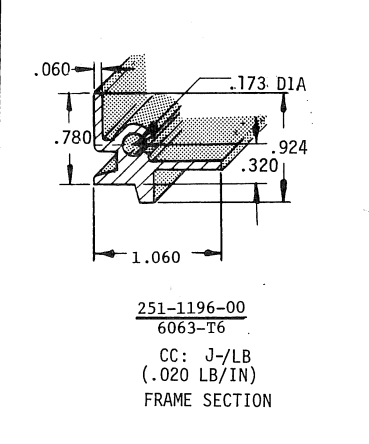
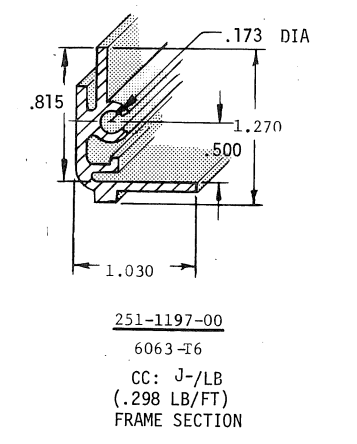

*ALUMINUM EXTRUSION (CONT)

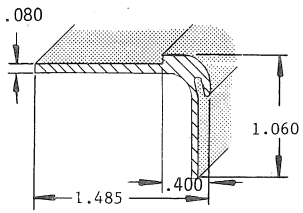

251-1208-00
6063-T6
CC: J-/LB
(.021 LB/IN)
FRAME SECTION

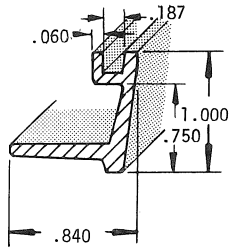

251-1336-00
6061-T6
CC: J+/LB
(.176 LB/FT)
FRAME SECTION

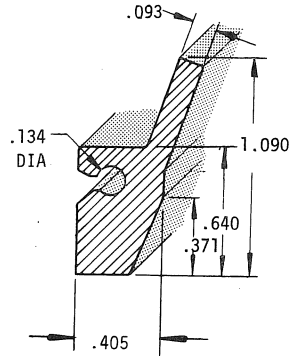

251-1296-00
6063-T6
CC: J-/LB
(.446 LB/FT)
SUPPORT BLOCK

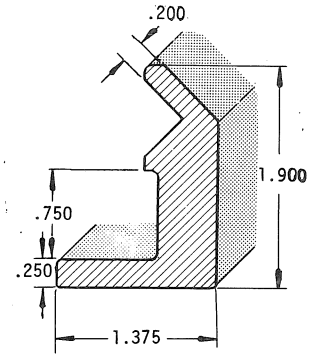

251-1396-00
6063-T6
CC: J+/LB
(1.29 LB/FT)
CLAMP

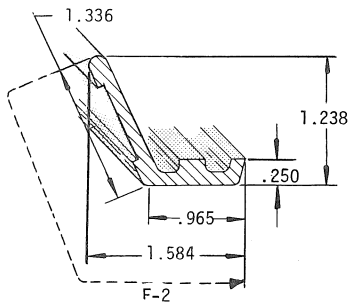

251-1425-00
6063-T6
CC: J/LB
(.440 LB/FT)
TRIM STRIP

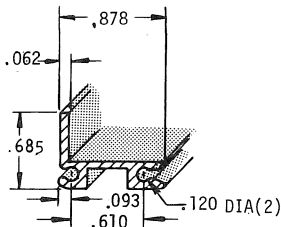

251-1132-00
6063-T6
CC: J-/LB
(.160 LB/FT)
SLIDE GUIDE

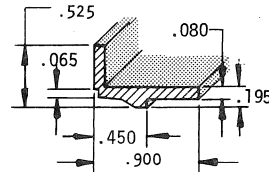

251-1147-00
6063-T6
CC: J-/LB
(.132 LB/FT)
SUPPORT

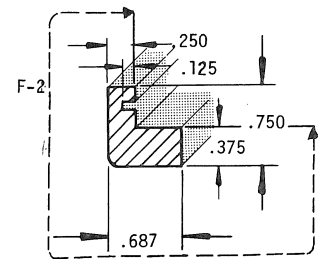

251-1291-00
6063-T6
CC: J-/LB (.406 LB/FT)
PAPER CUTTER SUPPORT

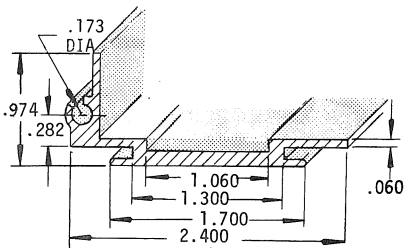

251-1194-00
6063-T6
CC: J-/LB
(.433 LB/FT)
FRAME SECTION

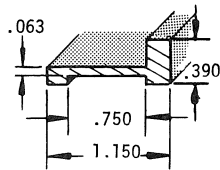

251-1346-00
6063-T6
CC: J/LB
(.188 LB/FT)
SHIELD

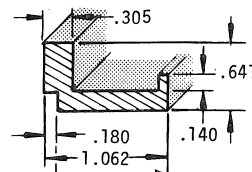

251-1302-00 F-1
6063-T6
CC: J+/LB
(.361 LB/FT)
ANGLE BRACKET

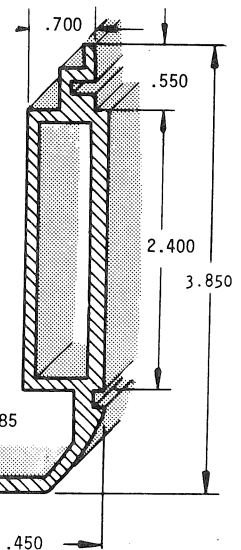

251-1111-00
6063-T6
CC: I/LB
(1.21 LB/FT)
FRAME SECTION

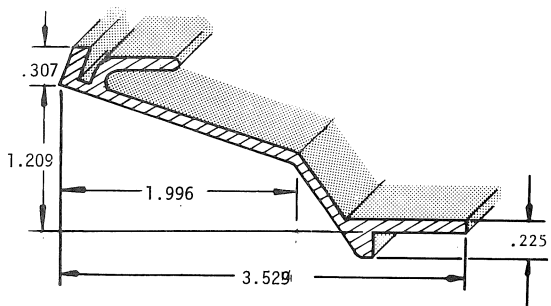

251-1367-00
6063-T5
CC: J-/LB
(.656 LB/FT)
FRAME SECTION

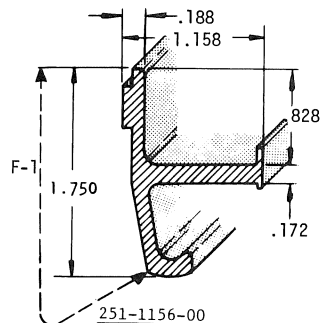

251-1156-00
6063-T6
CC: J/LB (.518 LB/FT)
F2 FINISH EXCEPT AS NOTED
RACK MOUNT BRACKET

6

* ALUMINUM EXTRUSION (CONT)

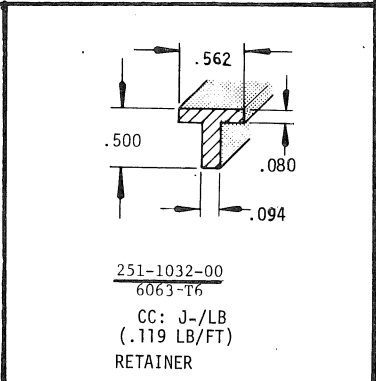
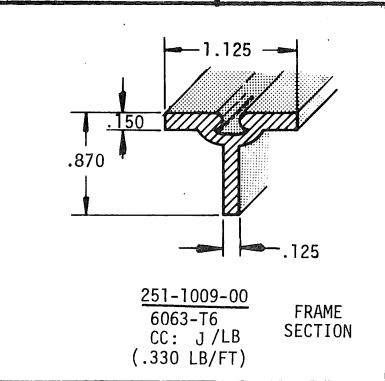
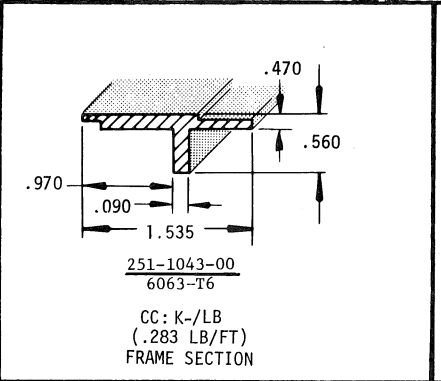
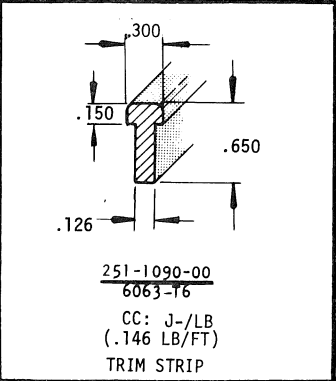
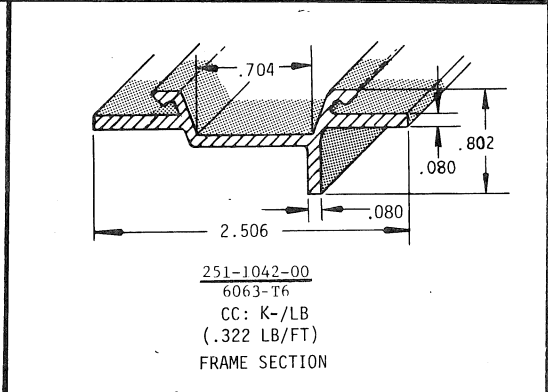
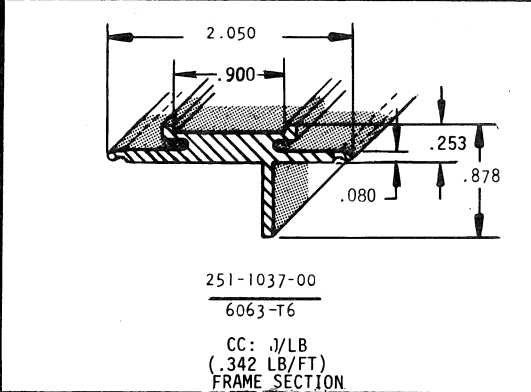
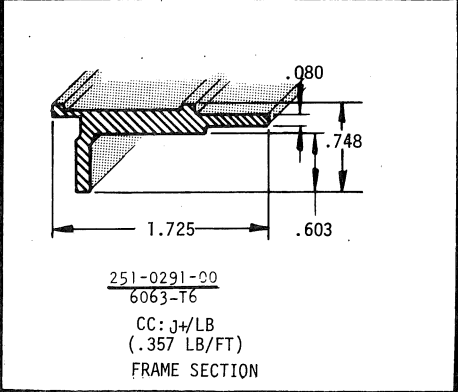
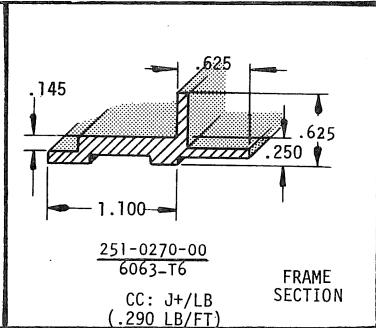
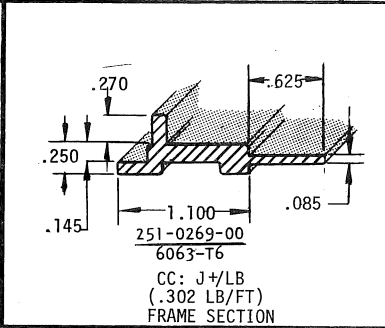
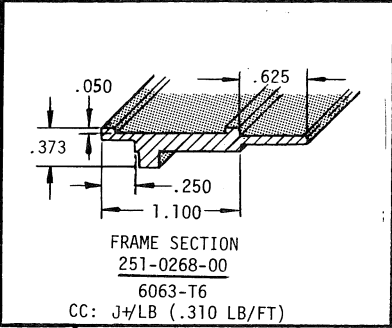
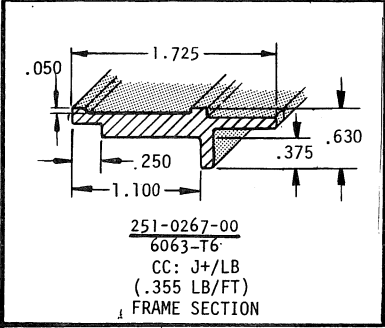
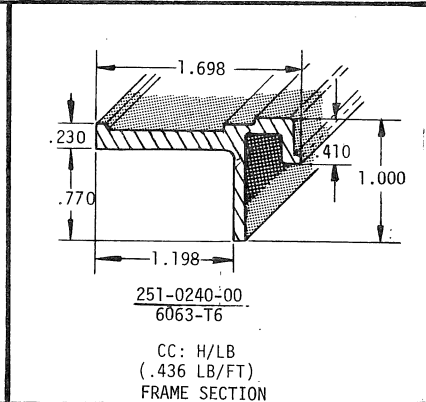
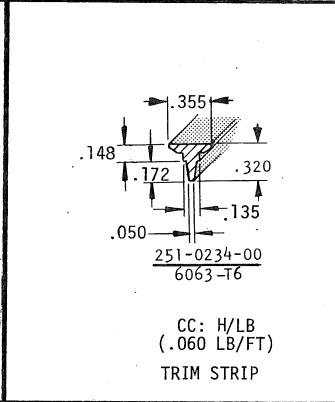
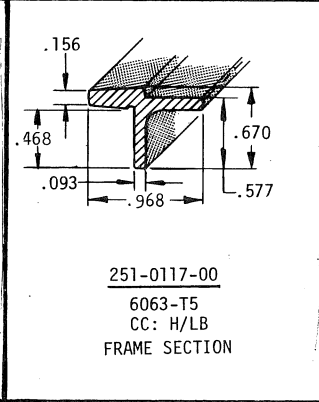
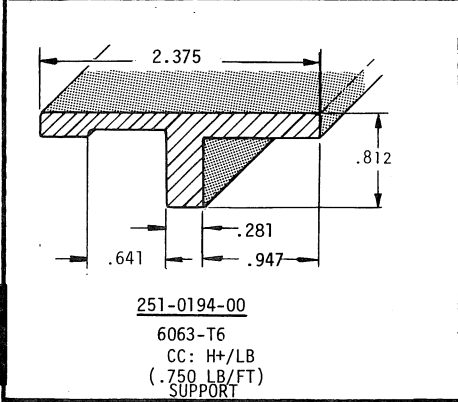
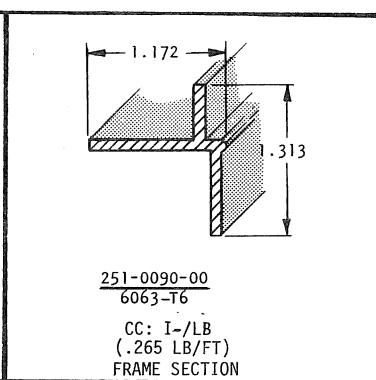
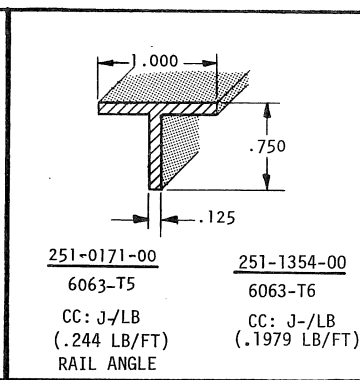
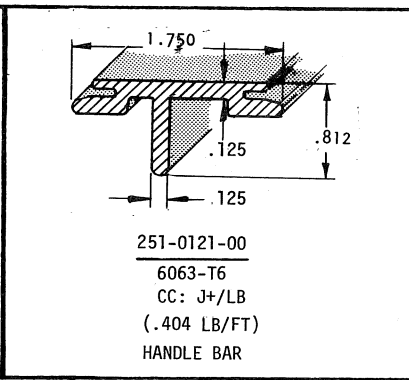
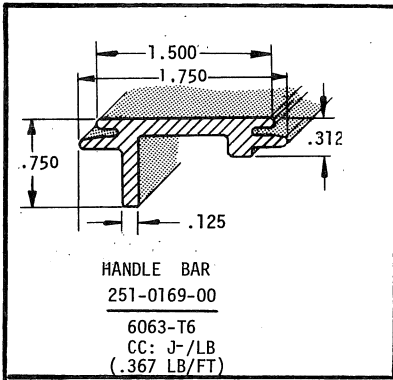

6

* ALUMINUM EXTRUSION (CONT)

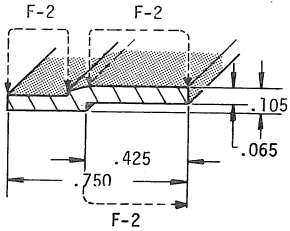

251-1640-00
6063-T6
CC: J+/LB
(.061 LB/FT)

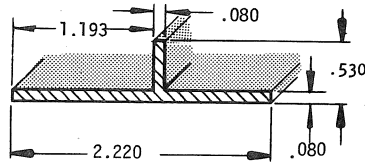

251-1120-00
6063-T6
CC: I+/LB
(.257 LB/FT)
FRAME SECTION

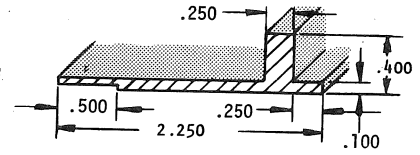

251-1184-00
6063-T6
CC: J/LB
(.322 LB/FT)
FRAME SECTION

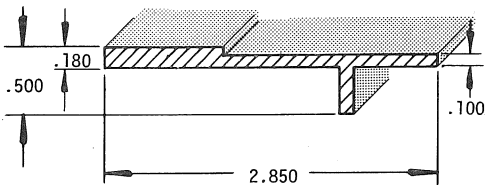

251-1263-00
6063-T6
CC: J-/LB
FRAME SECTION

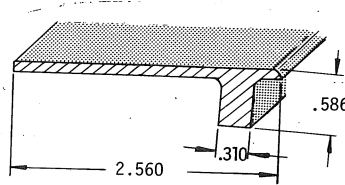

251-1380-00
6063-T6
CC: J+/LB
(.481 LB/FT)
HOLD DOWN BRACKET, COVER

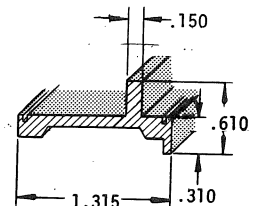

251-1303-00
6063-T6
CC: J/LB
(.247 LB/FT)
FRAME SECTION

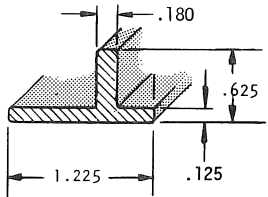

251-1177-00
6063-T6
CC: J+/LB
(.276 LB/FT)
HEAT SINK BRACKET

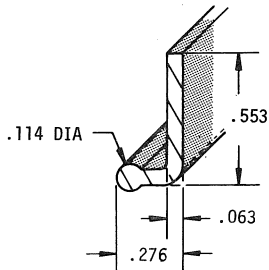

251-1678-00
6063-T6
CC: K/LB
(.060 LB/FT)

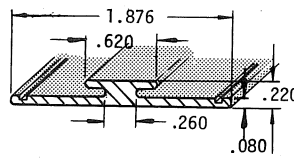

251-1105-00
6063-T6
CC: J/LB
(.247 LB/FT)
FRAME SECTION

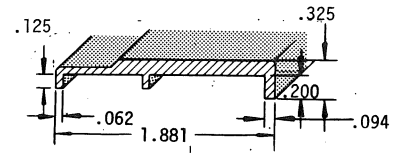

251-1371-00
6063-T6
CC: J-/LB
(.296 LB/FT)
RETAINER

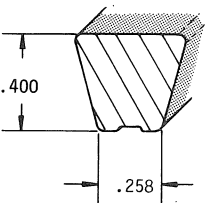

251-1709-00
6061-T6
CC: K+/LB
(.170 LB/FT)

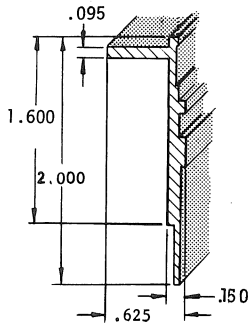

251-1226-00
6063-T6
CC: J/LB
(.022 LB/IN)
FRAME SECTION

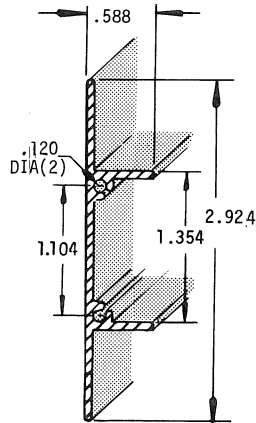

251-1221-00
6063-T6
CC: I+/LB
(.027 LB/IN)
CONNECTOR BRACKET

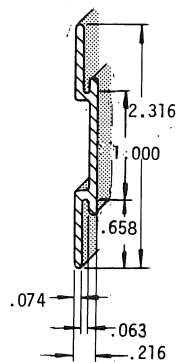

251-1434-00
6063-T6
CC: J-/LB
(.256 LB/FT)
FRAME SECTION

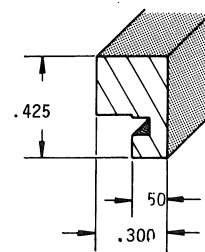

251-1680-00
6063-T6
CC: L-/LB
(.136 LB/FT)

* ALUMINUM EXTRUSION (CONT)

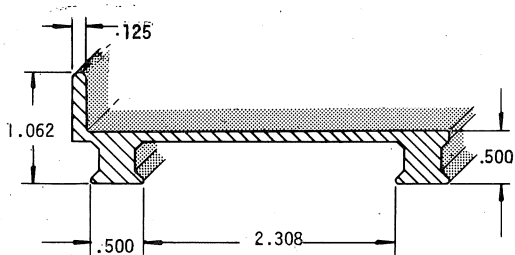

251-1074-00
6063-T6
CC: H+/LB
TRANSFORMER SUPPORT

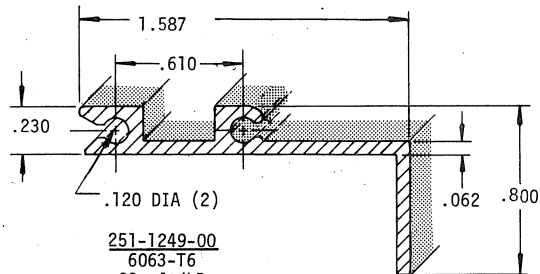

251-1249-00
6063-T6
CC: J+/LB
CIRCUIT BOARD FRAME

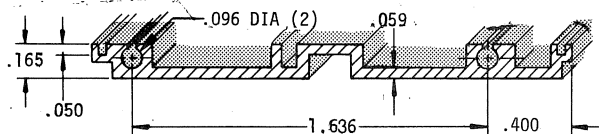

251-1222-00
6063-T6
CC: J /LB (.019 LB/IN)
FRAME SECTION

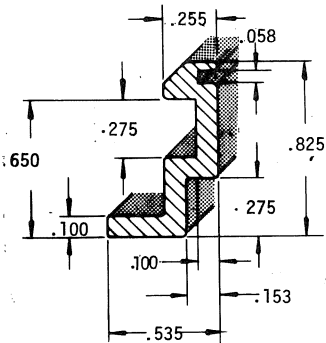

251-1496-00
6063-T6 (.050 LB/FT)
CC: J+/LB
GUIDE

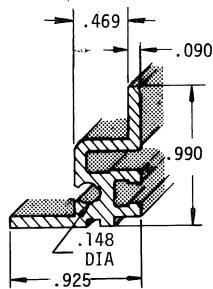

251-1469-00
6063-T6
CC: J+/LB
(.276 LB/FT)
FRAME SECTION

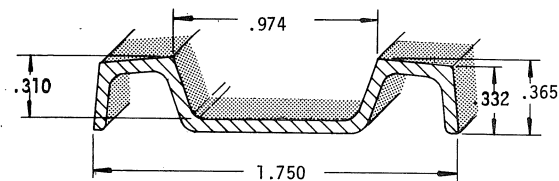

251-1079-00
6063-T6
CC: I+/LB
FRAME SECTION

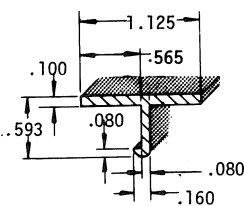

251-1499-00
2024-T3
CC: L/LB
(.188 LB/FT)
LATCH

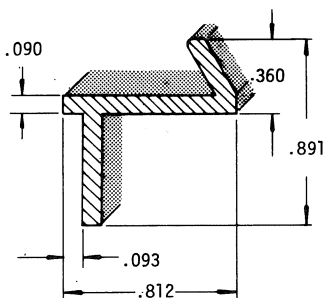

251-1563-00
6063-T6
CC: J/LB
(.178 LB/FT)
FRAME SECTION

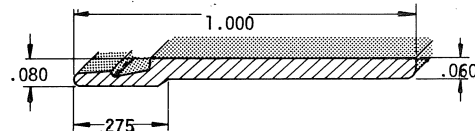

251-1064-00
6063-T6
CC: J+/LB (.061 LB/FT)
SHIELD GASKET RETAINER

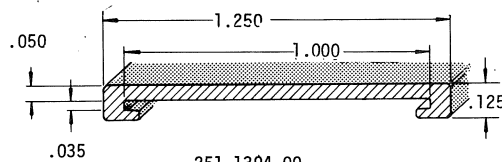

251-1394-00
6063-T6
CC: J/LB
(.094 LB/FT)
HOLDER

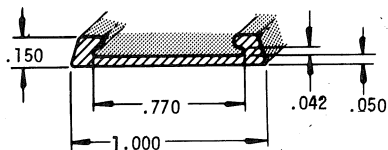

251-1447-00
6063-T6
CC: J/EA (.087 LB/FT)
RETAINER

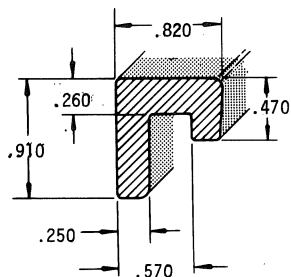

251-1069-00
6063-T6
CC: I+/LB
PANEL BRACKET

6

* ALUMINUM EXTRUSION (CONT)

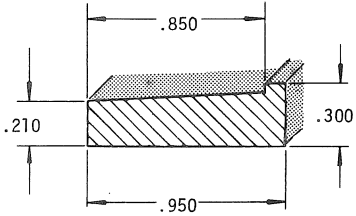

251-1510-00
6061-T6
CC: J/LB
(.285 LB/FT)
NUT BLOCK

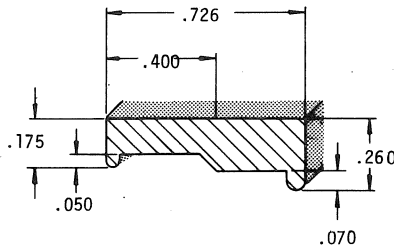

TRANSISTOR CLAMP
251-1569-00
6063-T6
CC: J-/LB
(.145 LB/FT)

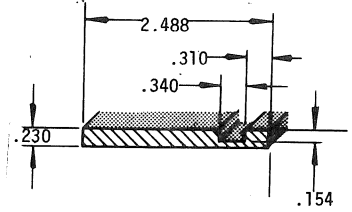

251-1461-00
6063-T6
CC: J+/LB
(.584 LB/FT)
COVER

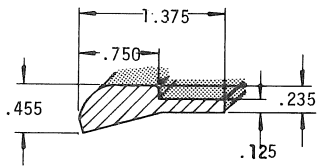

251-1572-00
6063-T6
CC: J+/LB
(.390 LB/FT)
HINGE SUPPORT

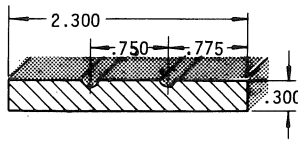

251-1541-00
6063-T6
CC: K+/LB
(.130 LB/FT)
DELAY LINE CLAMP

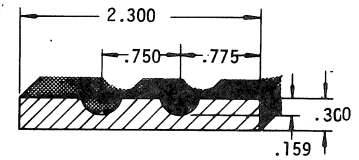

251-1540-00
6061-T6
CC: J+/LB
(.120 LB/FT)
DELAY LINE CLAMP

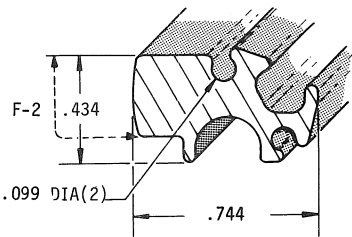

251-1582-00
6063-T6
CC: J+/LB (.221 LB/FT)
BODY, HEATER

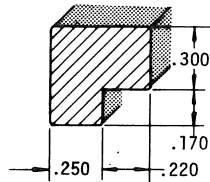

251-1497-00
6063-T6
CC: J+/LB
(.065 LB/FT)
SLIDE

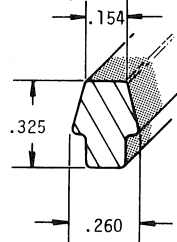

251-1578-00
6063-T6
CC: J+/LB
(.059 LB/FT)

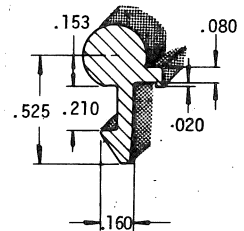

251-1498-00
2024-T3
CC: L/LB
(.142 LB/FT)
LATCH

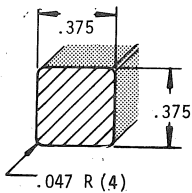

251-0193-00
6061-T6 CC: I/LB

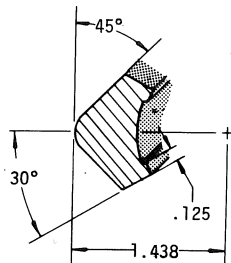

251-1462-00
6063-T6
CC: K-/LB
(.560 LB/FT)
SUPPORT

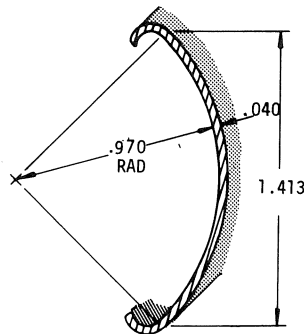

251-1566-00
6063-T5
CC: K-/LB
(.094 LB/FT)
PAPER GUIDE

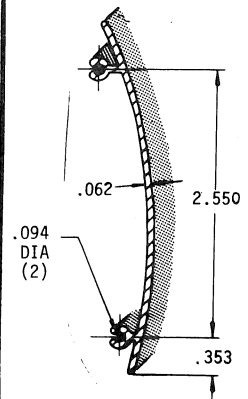

251-1503-00
6063-T6
CC: J+/LB
(.060 LB/FT)
FRAME SECTION

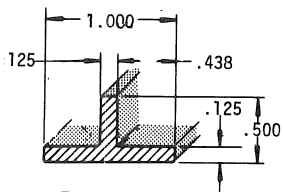

T-SHAPE
251-0098-00
6063-T6
CC: J/LB

* ALUMINUM EXTRUSION (CONT)

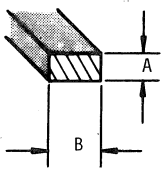
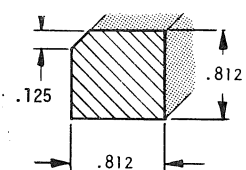
	PART NUMBER	A	B	ALLOY & TEMPER	CC	
	251-0224-00 251-1329-00 251-1285-00 251-1116-00	.125 .156 .250 .312	.500 .650 .250 3.250		6061-T6 6063-T6 6063-T5 2024-T351	
251-1482-00 251-0183-00 251-1451-00 251-1649-00 251-1095-00	.340 .375 .375 .375 .479	.634 .375 .545 .700 .600		6063-T6 6063-T5 6063-T6 6063-T6 2024-T4	K /LB J /LB (.169 LB/FT) J+/LB (.255 LB/FT) J-/LB L /LB (.338 LB/FT)	
251-1608-00	6.125	11.250		7075-T651	K-/LB	

251-0206-00
6063-T6
CC: I/LB (.900 LB/FT)

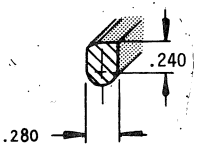

251-1097-00
6061-T6
CC: K+/LB
(.126 LB/FT)
CAMERA LATCH

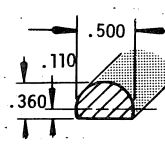

251-1297-00
6061-T6
CC: M+/LB
(.172 LB/FT)
PEN BAR, CAM

NUT BLOCK.

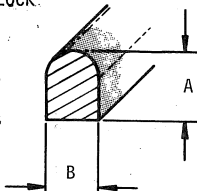

PART NUMBER	A	B	CC
251-0293-00 6061-T6	.412	.312	J+/LB (.140 LB/FT)
251-1594-00 6063-T6	1.250	.187	J+/LB (.122 LB/FT)

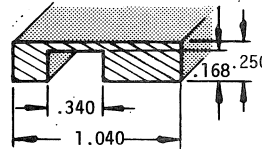

251-1360-00
6063-T6
CC: J /LB
(.247 LB/FT)
ELEC. SHIELD

F-2

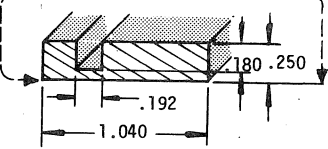

251-1361-00
6063-T6
CC: J /LB
(.267 LB/FT)
FRAME SECTION
F-O FINISH EXCEPT AS NOTED

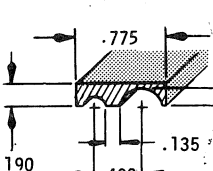

251-1143-00
6063-T6
CC: J-/LB
(.115 LB/FT)
HEAT SINK

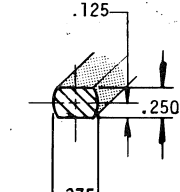

251-1088-01
2024-T4
CC: J+/LB
(.103 LB/FT)
HOLD DOWN

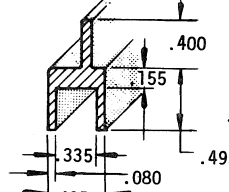

251-1073-00
6063-T6
CC: J+/LB
(.199 LB/FT)
CIRCUIT BOARD SUPPORT

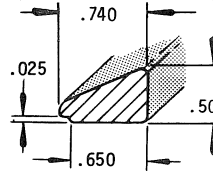

251-1094-00
6063-T6
CC: J /LB
(.307 LB/FT)
CAMERA HANDLE

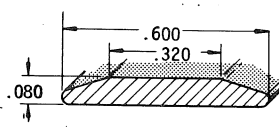

251-1076-00
6063-T6
CC: J+/LB
(.046 LB/FT)
SHIELD, GASKET RETAINER

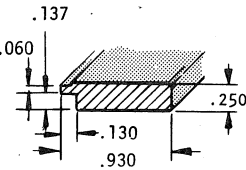

251-0275-00
6063-T6
CC: K-/LB
(.239 LB/FT)
FRAME SECTION

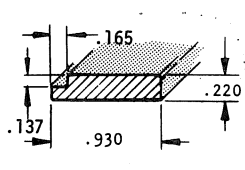

251-0276-00
6063-T6
CC: K-/LB
(.205 LB/FT)
FRAME SECTION

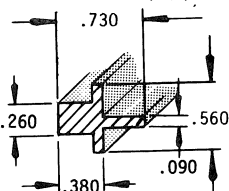

251-1089-00
6063-T6
CC: K+/LB
(.182 LB/FT)
FRAME SECTION

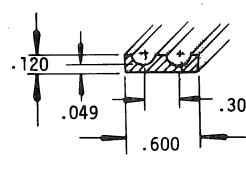

251-1072-00
6063-T6
CC: F-/OZ
(.059 LB/FT)
TRANS. COVER

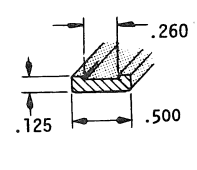

251-1244-00
6063-T6
CC: J /LB
(.063 LB/FT)
CARRYING HANDLE

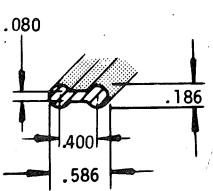

251-1323-00
6061-T6
CC: M /LB
(.081 LB/FT)
PEN MECH. LINK

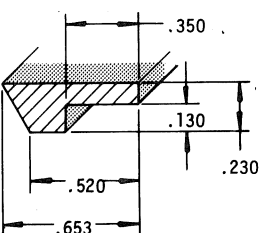

251-1485-00
6063-T6
CC: K /LB
(.150 LB/FT)
LATCH

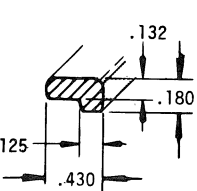

251-1300-00
7075-T6
CC: N-/LB
(.074 LB/FT)
NUT BLOCK

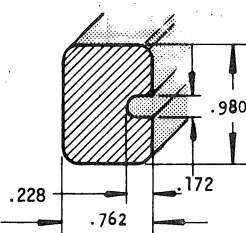

251-1030-00
6061-T6
CC: K+/LB
(.936 LB/FT)
HEAT SINK

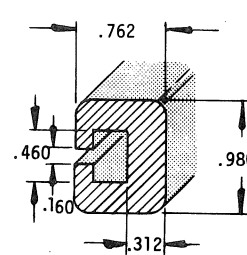

251-1029-00
6061-T68
CC: J+/LB
(.682 LB/FT)
HEAT SINK

* FOR MECHANICAL PROPERTIES & TOLERANCES, SEE PAGES 6-43 THRU 6-48.

* ALUMINUM EXTRUSION (CONT)

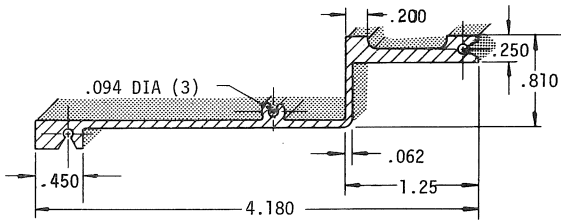

251-1505-00
6063-T6
CC: J+/LB
(.200 LB/FT)
FRAME

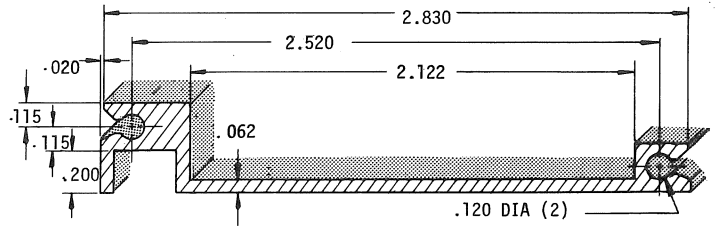

251-1085-00
6063-T6
CC: K/LB
(.322 LB/FT)
FRAME SECTION

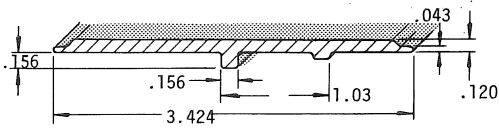

251-1435-00
6063-T6
CC: J+/LB
(.524 LB/FT)
ADAPTER PLATE

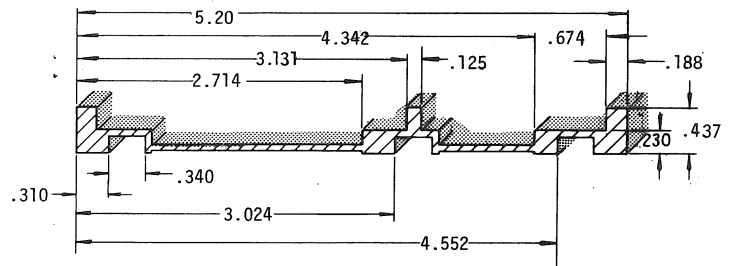

251-1489-00
6061-T6
CC: J+/LB
(.697 LB/FT)
SUPPORT

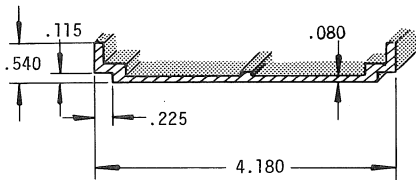

251-1506-00
6063-T6
CC: J-/LB
(.634 LB/FT)
SHIELD

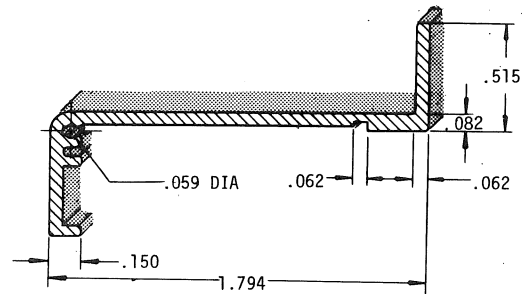

FRAME SECTION
251-1504-00
6063-T6
CC: J/LB
(.031 LB/FT)

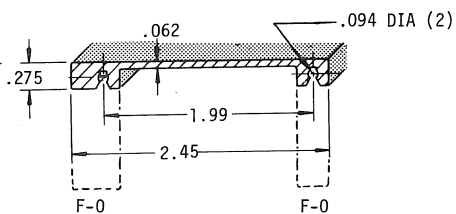

251-1502-00
6063-T6
CC: J /LB (.062 LB/FT)
F-1 FINISH EXCEPT AS NOTED
FRAME SECTION

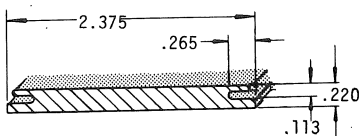

251-1477-00
6063-T6
CC: J /LB
(.400 LB/FT)
FRAME SECTION

COST CODE (CC COLUMN)

CODE	A	B	C	D	E	F	G	H	I	J	K	L	M	N	O
≈ VALUE with +	.75¢	2¢	3.75¢	6¢	10¢	18¢	35¢	60¢	\$1	\$2	\$3.75	\$6	\$10	\$18	\$35+
≈ VALUE no suffix	.5¢	1.5¢	3¢	5¢	8¢	15¢	25¢	50¢	75¢	\$1.50	\$3	\$5	\$8	\$15	\$25
≈ VALUE with -	.2¢	1.25¢	2.5¢	4.25¢	7¢	13¢	22¢	40¢	65¢	\$1.25	\$2.50	\$4.25	\$7	\$13	\$22

NOTE: Costs may vary from order to order due to order quantities, vendor, etc.

* ALUMINUM EXTRUSION (CONT)

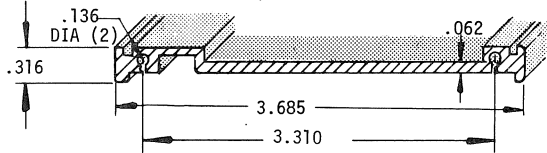

251-0277-00
6063-T6
CC: J/LB
(.383 LB/FT)
FRAME SECTION

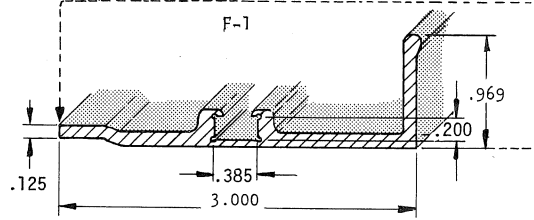

251-0134-00
6063-T6
CC: J-/LB
(.620 LB/FT)
GUIDE

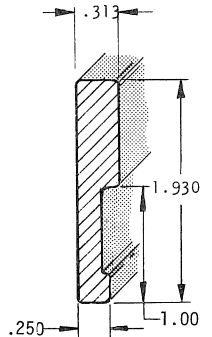

251-0283-00
6061-T6
CC- J+/LB
(.600 LB/FT)
HINGE HALF

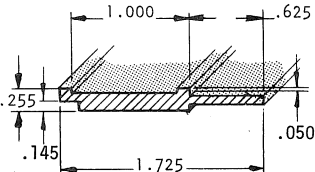

251-0278-00
6063-T6
CC: L+/LB
(.232 LB/FT)
FRAME SECTION

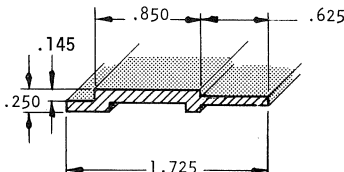

251-0279-00
6063-T6
CC: J+/LB
(.180 LB/FT)
FRAME SECTION

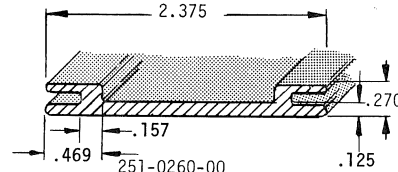

251-0260-00
6063-T6
CC: J-/LB
(.435 LB/FT)
TILT LOCK SUPPORT

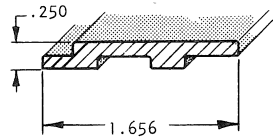

251-0217-00
6063-T6
CC: L+/LB
(.198 LB/FT)
FRAME SECTION

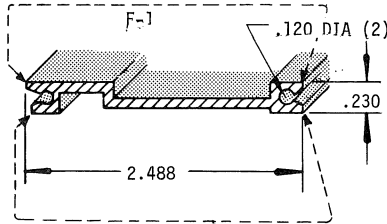

F-2
251-1023-00
6063-T6
CC: J+/LB
(.262 LB/FT)
FRAME SECTION

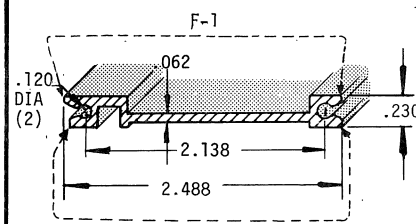

F-2
251-1024-00
6063-T6
CC: J/LB
(.263 LB/FT)
FRAME SECTION

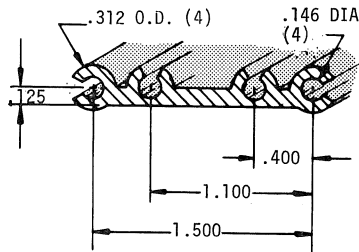

251-1598-00
6063-T6
CC: J+/LB (.300 LB/FT)
HEAT SINK

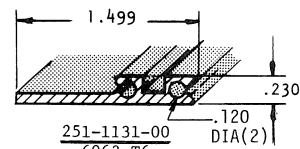

251-1131-00
6063-T6
CC: J+/LB
(.163 LB/FT)
CIRCUIT BOARD CONNECTOR SUPPORT

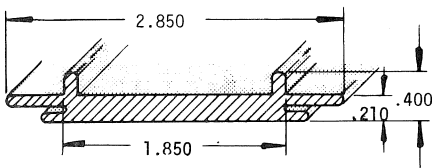

251-1044-00
6063-T6
CC: H/LB
FRAME SECTION

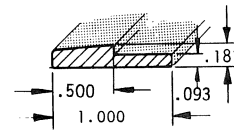

251-0176-00
6063-T5
CC: K/LB
(.178 LB/FT)
TRIM

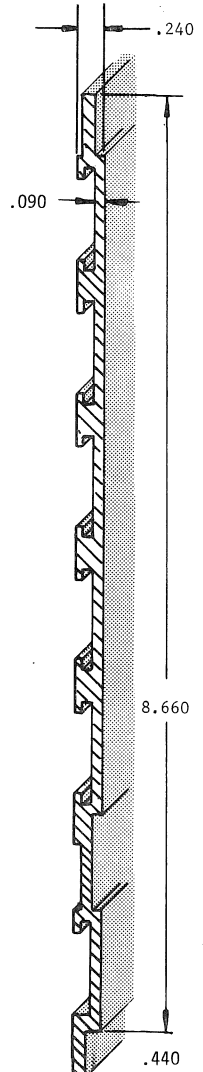

251-0239-00
6063-T6
CC: I-/LB
(1.360 LB/FT)
SCOPE COVER

6

* ALUMINUM EXTRUSION (CONT)

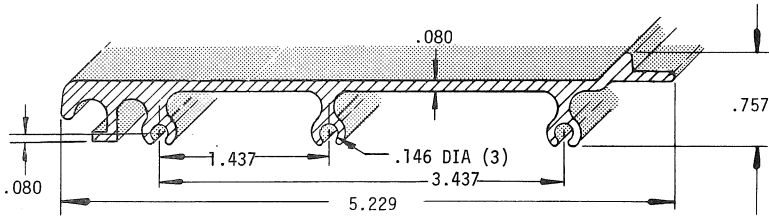

251-1142-00
6063-T6
CC: I/LB
FRAME SECTION

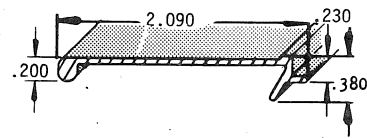

251-1164-00
6063-T6
CC: J-/LB
(.163 LB/FT)
FRAME SECTION

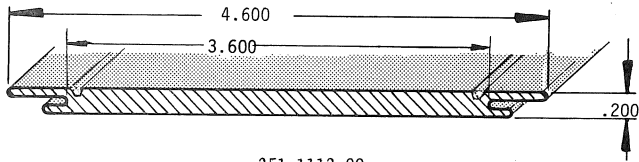

251-1112-00
6063-T6
CC: J-/LB
(.964 LB/FT)
FRAME SECTION

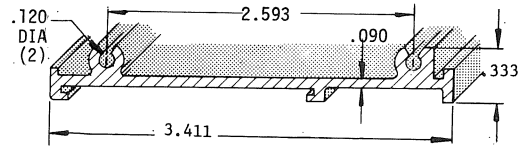

251-1268-00
6063-T6
CC: J-/LB
(.565 LB/FT)
FRAME SECTION

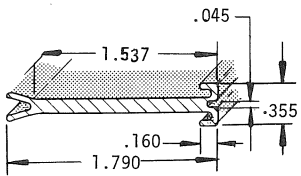

251-1210-00
6063-T6
CC: J /LB
(.281 LB/FT)
RACK MOUNT SPACER

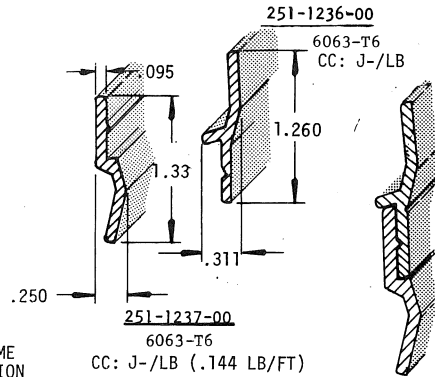

251-1236-00
6063-T6
CC: J-/LB
FRAME SECTION

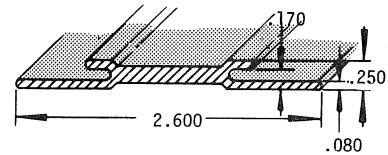

251-1162-00
6063-T6
CC: J /LB
(.370 LB/FT)
FRAME SECTION

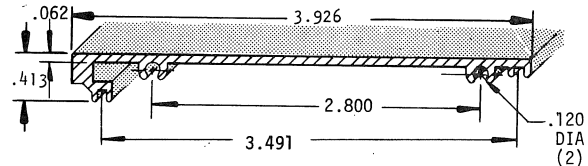

251-1127-00
6063-T6
CC: J-/LB (.424 LB/FT)
FRAME SECTION

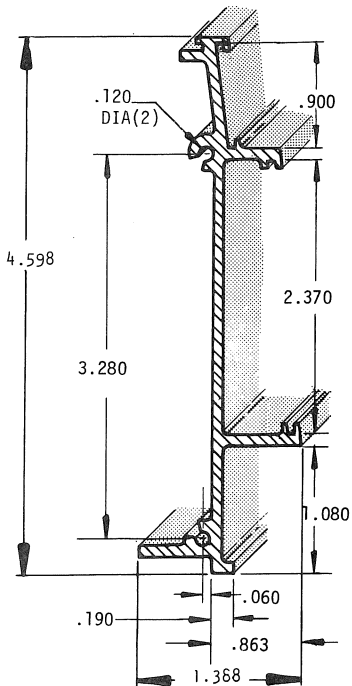

251-1114-00
6063-T6
CC: J /LB
(.832 LB/FT)
FRAME SECTION

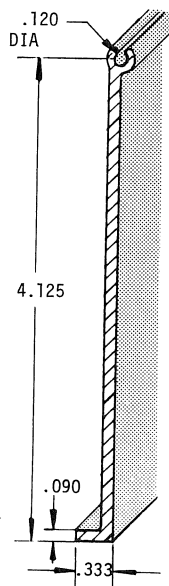

251-1174-00
6063-T6
CC: J /LB
(.499 LB/FT)
CIRCUIT BOARD COVER

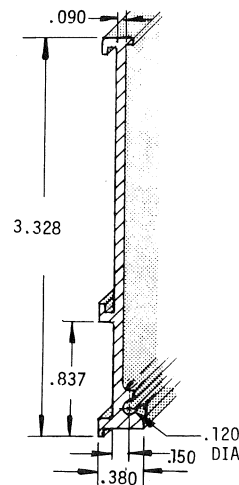

251-1175-00
6063-T6
CC: J-/LB
(2.439 LB/FT)
FRAME SECTION

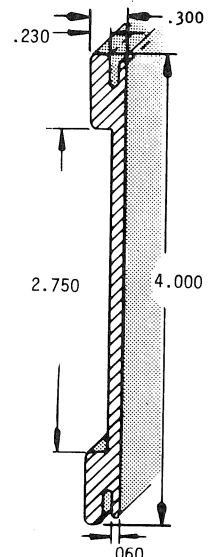

251-1163-00
6063-T6
CC: J /LB
(.741 LB/FT)
FRAME SECTION

*FOR MECHANICAL PROPERTIES & TOLERANCES, SEE PAGES 6-43 THRU 6-48.

* ALUMINUM EXTRUSION (CONT)

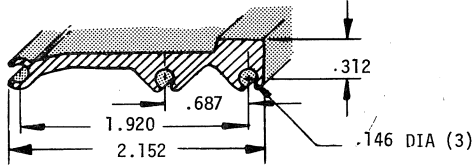

251-1141-00
6063-T6
CC: I/LB
FRAME SECTION

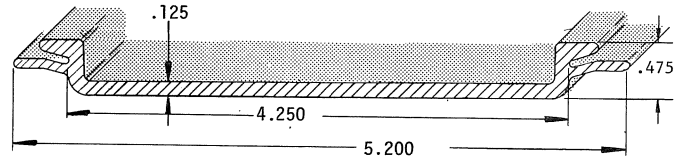

251-1264-00
6063-T6
CC: J-/LB
(.112 LB/IN)
FRAME SECTION

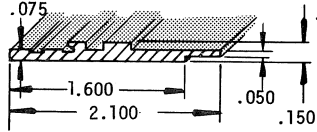

251-1261-00
6063-T6
CC: J /LB
(.013 LB/IN)
FRAME SECTION

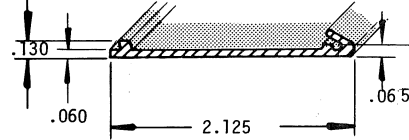

251-1260-00
6063-T6
CC: J-/LB
(.162 LB/FT)
LENS COVER

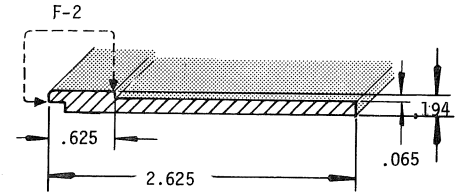

251-1314-00
6063-T6
CC: J-/LB (.434 LB/FT)
F-1 EXCEPT AS NOTED
FRAME SECTION

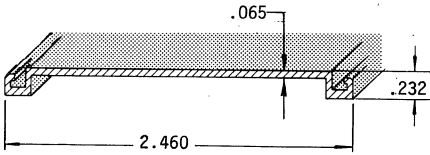

251-1369-00
6063-T6
CC: J+/LB
(.225 LB/FT)
FRAME SECTION

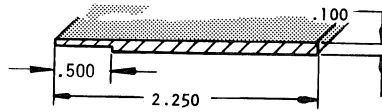

251-1185-00
6063-T6
CC: J-/LB
(.234 LB/FT)
FRAME SECTION

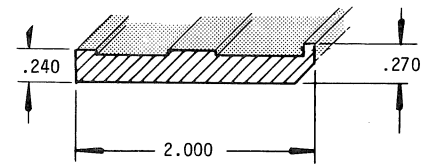

251-1353-00
6063-T6
CC: J+/LB
(.576 LB/FT)
FRAME SECTION

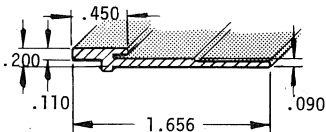

251-0216-00
6063-T6
CC: J-/LB
(.198 LB/FT)
FRAME SECTION

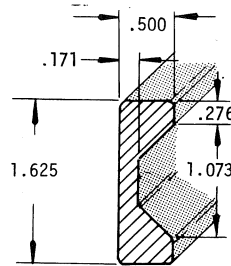

251-1428-00
6063-T6
CC: J /LB (.642 LB/FT)
BRACKET

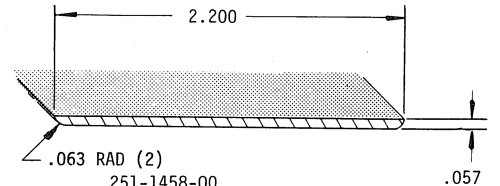

251-1458-00
6063-T6
CC: J+/LB
(.165 LB/FT)
COVER

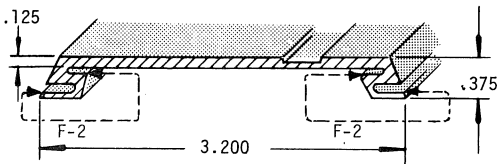

251-1315-00
6063-T6
CC: J-/LB (.556 LB/FT)
FRAME SECTION

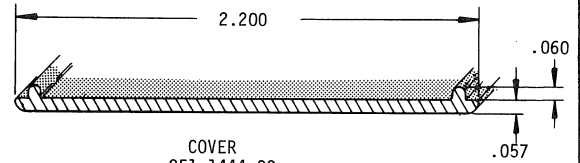

251-1444-00
6063-T6
CC: K-/LB (.171 LB/FT)
COVER

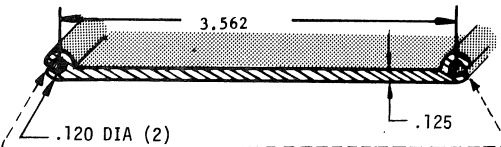

251-1304-00
6063-T6
CC: J-/LB (.456 LB/FT)
FRAME SECTION

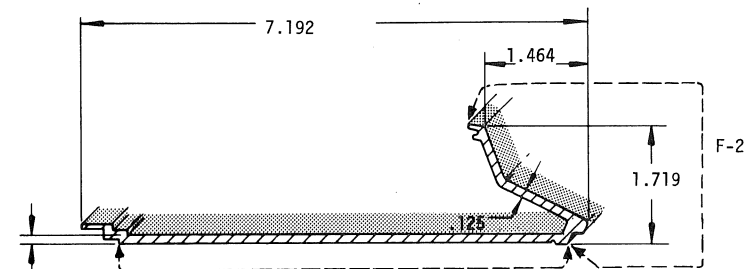

251-1376-00
6063-T6
CC: I+/LB
(1.42 LB/FT)
FRAME SECTION

6

* ALUMINUM EXTRUSION (CONT)

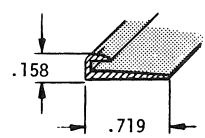
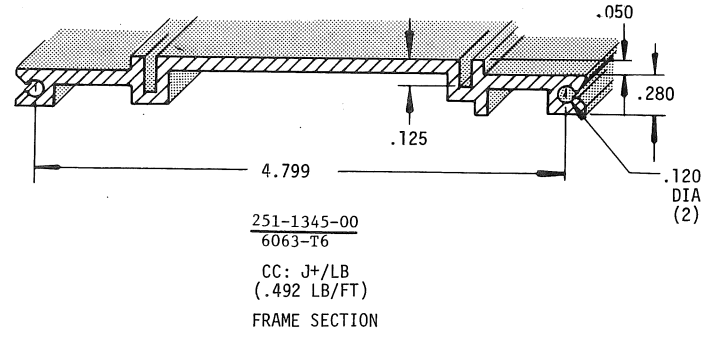
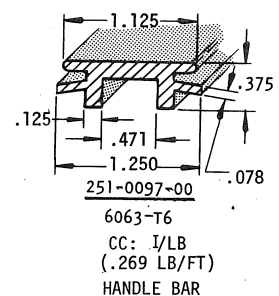
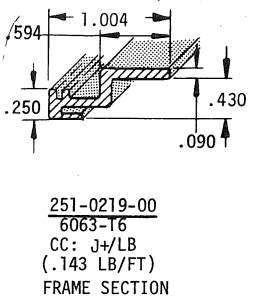
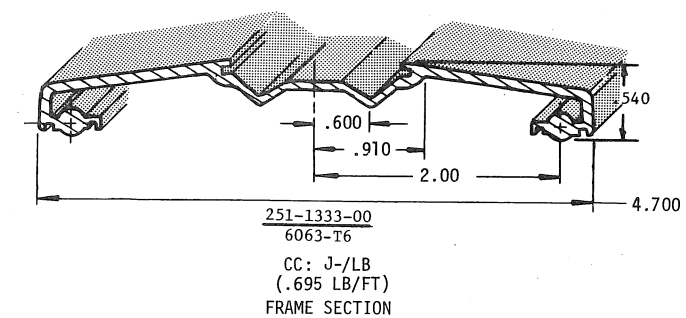
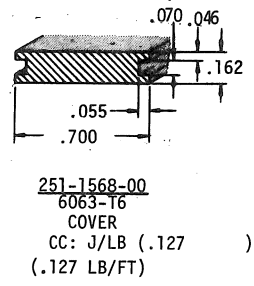
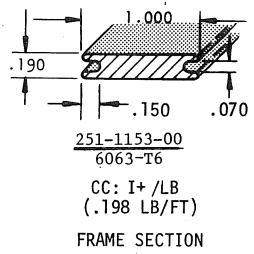
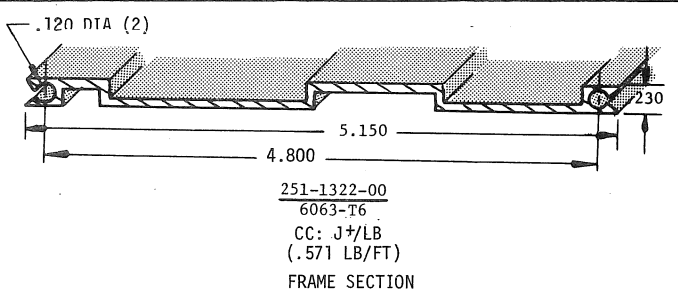
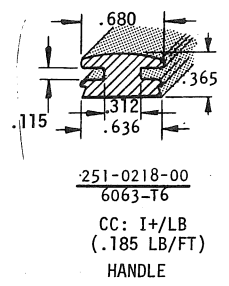
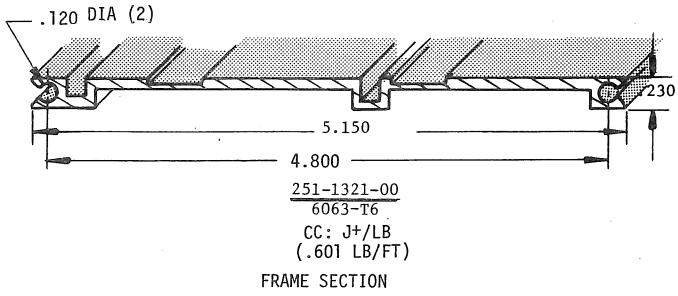

251-0137-01 81.1719 long CC: I+/ea
 251-0184-01 88.1719 long CC: I+/ea
 6063-T42
 (.059 LB/FT)

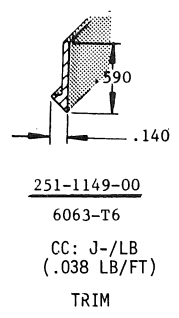
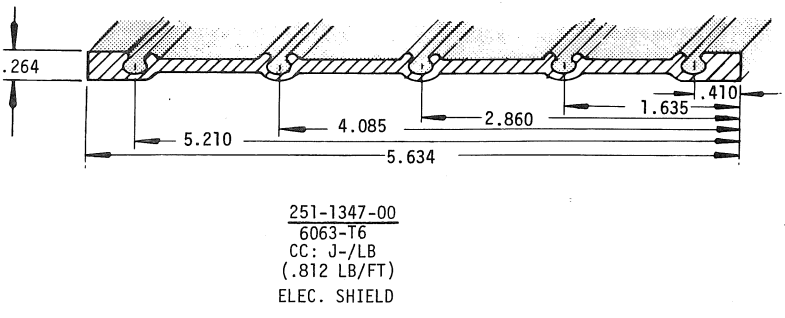

6

*FOR MECHANICAL PROPERTIES & TOLERANCES, SEE PAGES 6-43 THRU 6-48.

* ALUMINUM EXTRUSION (CONT)

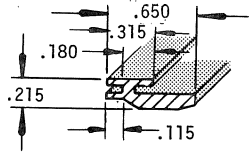

251-1065-00
6063-T6
CC: J+/LB
(.076 LB/FT)
FRAME SECTION

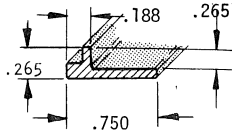

251-0252-00
6063-T5
CC: J+/LB
(.085 LB/FT)
PLATE NUT

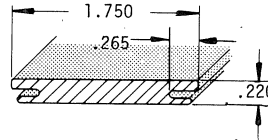

251-1325-00
6063-T6
CC: J /LB
(.409 LB/FT)
FRAME SECTION

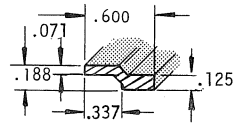

251-0228-00
6063-T6
CC: I+/LB
(.070 LB/FT)
GUIDE

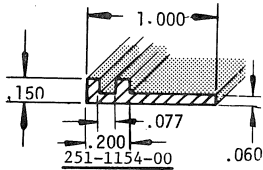

251-1154-00
6063-T6
CC: K-/LB
(.083 LB/FT)
CIRCUIT BOARD SUPPORT

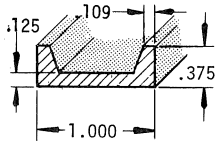

251-0102-00
6063-T6
CC: J-/LB
(.239 LB/FT)
CHANNEL

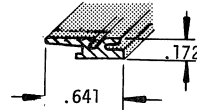

251-1205-00
6063-T6
CC: J+/LB
(.006 LB/IN)
TRIM

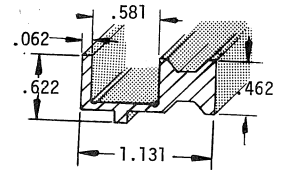

251-1192-00
6063-T6
CC: J-/LB
(.025 LB/IN)
TRANSFORMER SUPPORT

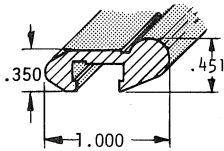

251-0204-00
6063-T6
CC: I+/LB
(.370 LB/FT)
GUIDE SLIDE

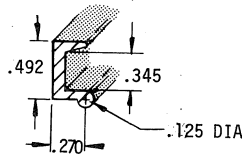

251-1195-00
6063-T6
CC: J-/LB
(.008 LB/IN)
FRAME SECTION

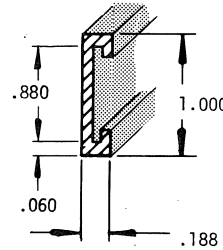

IDENT. PLATE HOLDER
251-1349-00
6063-T5
CC: J-/LB
(.129 LB/FT)

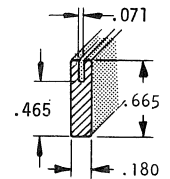

251-0257-00
6063-T6
CC: J-/LB
(.117 LB/FT)
FRAME SECTION

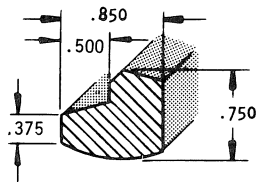

251-1176-00
6063-T6
CC: J /LB
(.529 LB/FT)
CRT PAD

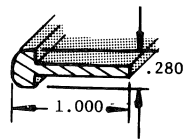

251-1332-00
6063-T6
CC: I+/LB
(.131 LB/FT)
TRIM STRIP

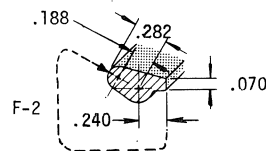

251-1386-00
6063-T6
CC: I+/LB (.102 LB/FT)
F-0 FINISH EXCEPT AS NOTED
CATCH LATCH

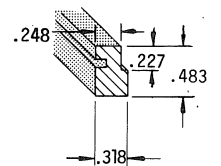

251-1393-00
6063-T6
CC: J-/LB
(.193 LB/FT)
CIRCUIT BOARD SUPPORT

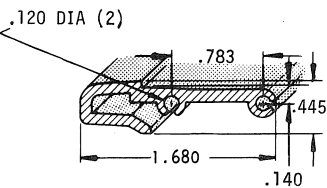

251-1098-00
6063-T6
CC: J-/LB
FRAME SECTION

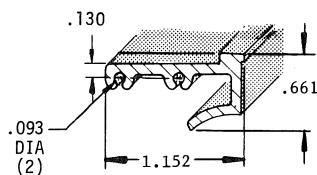

251-1206-00
6063-T6
CC: J-/LB
(.226 LB/FT)
FRAME SECTION

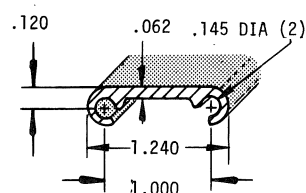

251-1258-00
6063-T6
CC: J-/LB
(.117 LB/FT)
KNOB GUARD

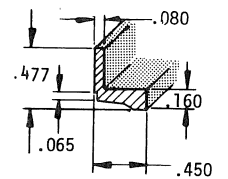

251-1146-00
6063-T6
CC: J /LB
(.075 LB/FT)
ELEC. SHIELD SUPPORT

*ALUMINUM EXTRUSION (CONT)

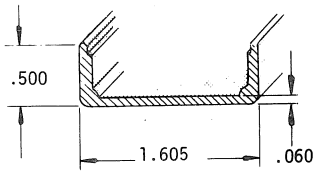

251-1225-00
6063-T6
CC: J+/LB (.216 LB/FT)
HOUSING

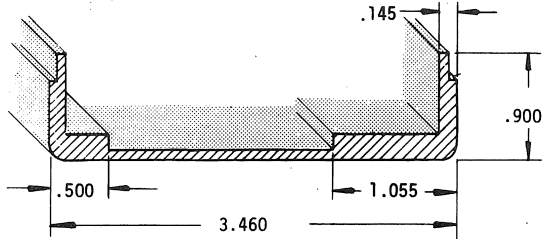

251-1265-00
6063-T6
CC: J /LB (.867 LB/FT)
FRAME SECTION

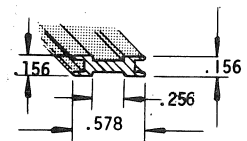

251-1229-00
6063-T6
CC: H /FT
GUIDE, SLIDE

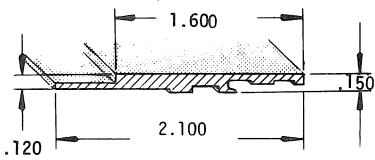

251-1252-00
6063-T6
CC: J /LB (.019 LB/IN)
FRAME SECTION

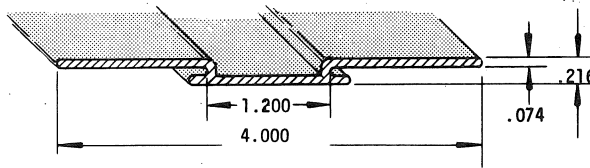

251-1266-00
6063-T6
CC: J+/LB (.403 LB/FT)
FRAME SECTION

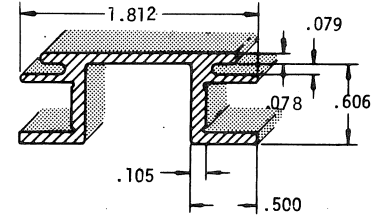

251-0185-00
6063-T6
CC: I+/LB
HANDLE

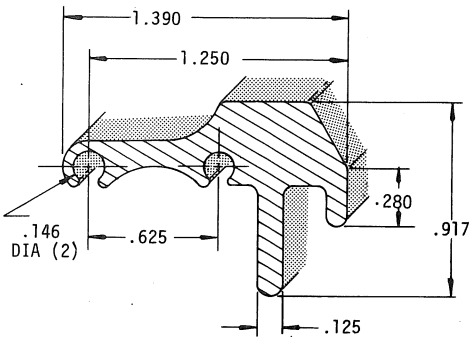

251-1140-01
6063-T6
(.518 LB/FT)
FRAME SECTION

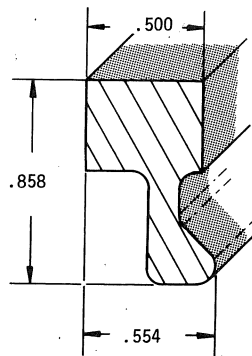

251-1616-00
6063-T6
CC: K /LB (.330 LB/FT)
(.330 LB/FT)

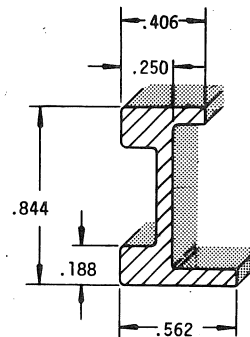

251-0104-00
6063-T6
(.200 LB/FT)
FRAME SECTION

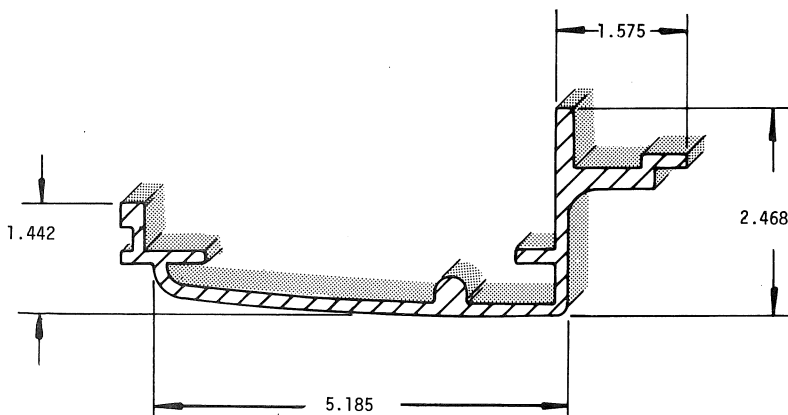

251-1071-00
6063-T6
CC: H /LB (2.472 LB/FT)
FRAME SECTION

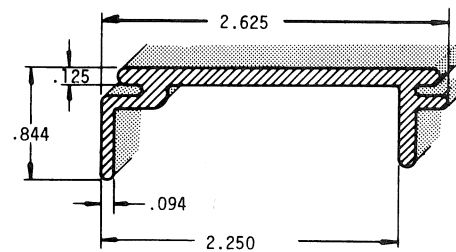

251-0189-00
6063-T6
CC: J /LB
FRAME SECTION

* ALUMINUM EXTRUSION (CONT)

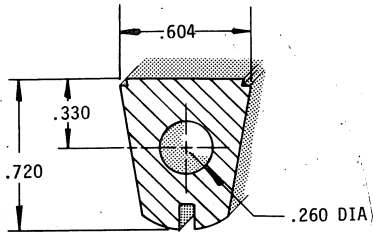

251-0292-00
6061-T6
CC: I/LB
(.360 LB/FT)

HANDLE

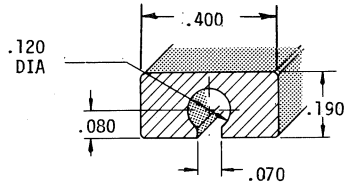

251-1108-00
6063-T6
CC: J-/LB
(.070 LB/FT)

NUT BLOCK

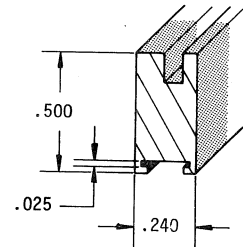

251-1701-00
6063-T6
CC: K /LB
(.136 LB/FT)

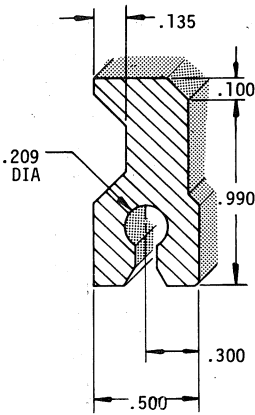

251-1052-00
6063-T6
CC: I/LB
(.432 LB/FT)

TRANSFORMER SLIDE

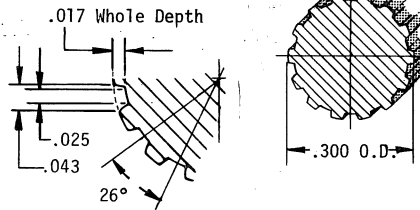

251-1472-00
6061-T6
CC: K /LB
(.078 LB/FT)
KNOB

NO. TEETH 14

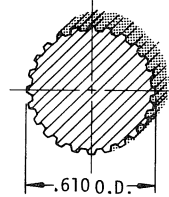

251-1470-00
6061-T6
CC: J+/IN
DIAMETRAL PITCH 40 NO. TEETH 24
GEAR

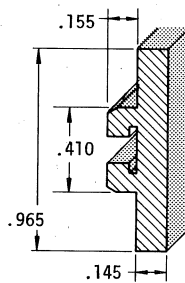

251-1522-00 6063-T6
CC: K+ /lb
(.216 lbs/ft)
PLATE ATTENUATOR

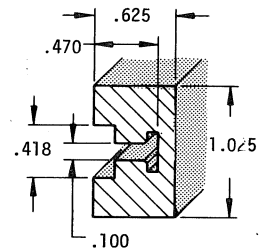

251-1523-00 6063-T6
CC: L-/LB (.566 LB/FT)

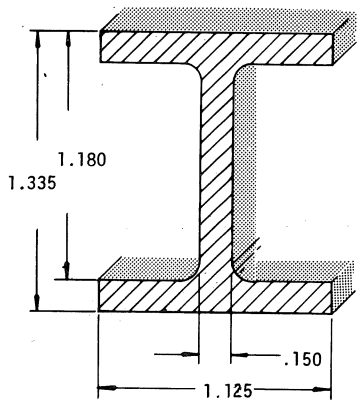

251-1077-00
6063-T6
CC: H /LB
(.619 LB/FT)
SUPPORT BAR

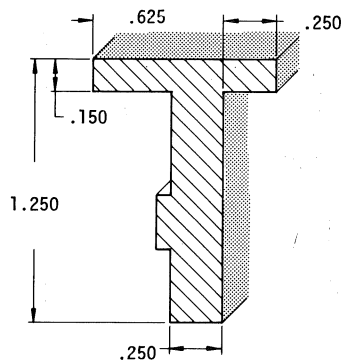

251-1534-00 6063-T6
J+/lb
(.385 lbs/ft)
SUPPORT, SWITCH

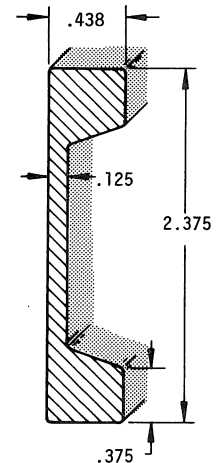

251-0088-00 6063-T6
CC: H/1b
SUPPORT

* ALUMINUM EXTRUSION (CONT)

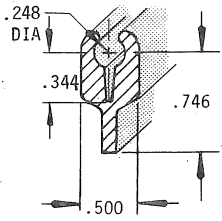

251-1223-00
6063-T6
CC: I+/LB
(.026 LB/IN)
SWITCH LEVER

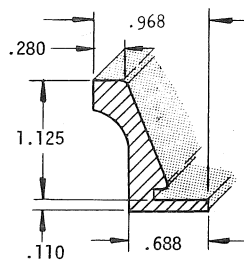

251-0282-00
6061-T6
CC: I/LB
(.392 LB/FT)
HINGE HALF

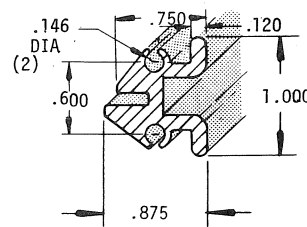

251-1135-00
6063-T6
CC: I/LB
FRAME SECTION

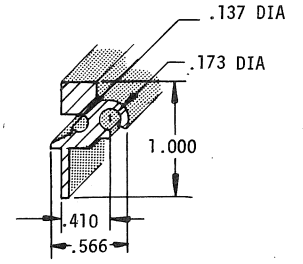

251-1193-00
6063-T6
CC: J-/LB
(.020 LB/IN)
Mate with 251-1195-00 and
251-1196-00
FRAME SECTION

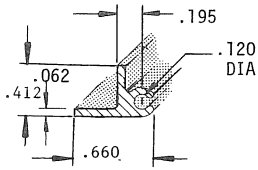

251-1200-00
6063-T6
CC: J+/LB
(.097 LB/FT)
GUIDE

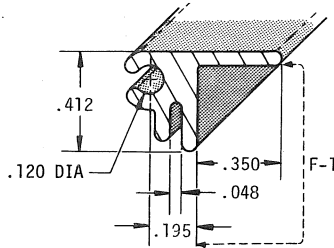

251-1704-00
6063-T6
CC: J+/LB
(.115 LB/FT)

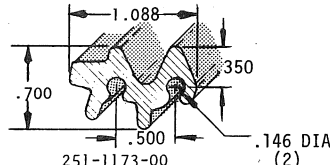

251-1173-00
6063-T6
(.401 LB/FT)
FRAME SECTION

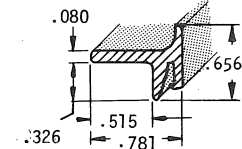

251-0128-00
6063-T6
CC: I+/LB
ANGLE BRACE

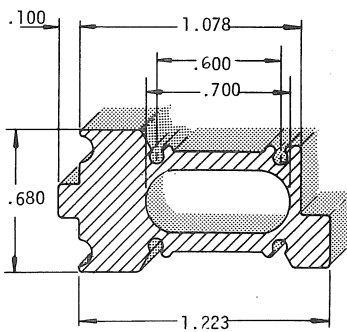

TEMP. STABILIZER
251-1331-00
6063-T6
CC: J+/LB
(.511 LB/FT)

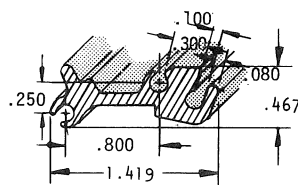

251-1137-00
6063-T6
CC: I+/LB
(.298 LB/FT)
FRAME SECTION

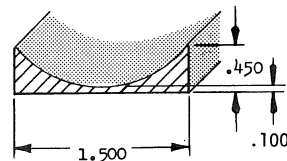

251-1201-00
6063-T6
CC: J-/LB
(.022 LB/IN)
HEAT SINK

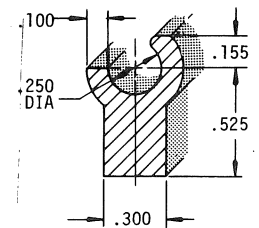

HINGE HALF
251-1060-00
6063-T6
CC: I+/LB (.199 LB/FT)
Mate with 251-1061-00

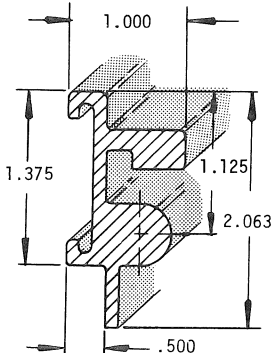

251-1278-00
6063-T6
CC: J-/LB
(.782 LB/FT)
FRAME SECTION

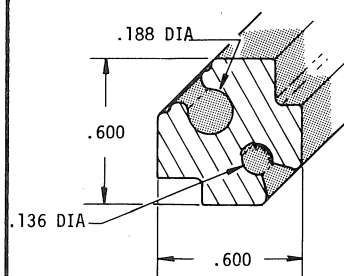

251-1697-00
6063-T6
CC: K/LB
(.254 LB/FT)

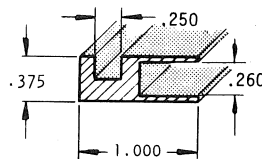

251-0186-00
6063-T6
CC: I+/LB
CHANNEL GUIDE

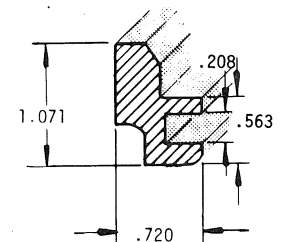

251-1271-00
6063-T6
CC: J/LB
(.502 LB/FT)
HEAD MOUNT

* ALUMINUM EXTRUSION (CONT)

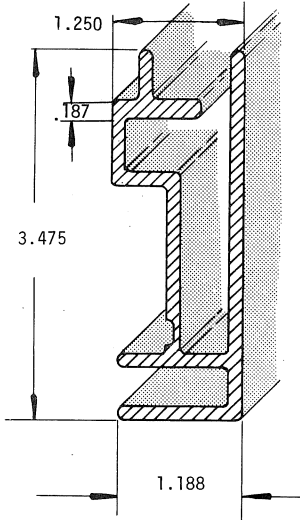

HANDLE
 251-1423-00
 6063-T6
 CC: J+/LB (1.45 LB/FT)

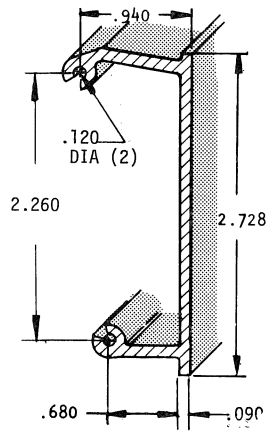

251-1115-00
 6063-T6
 CC: J+/LB
 (.623 LB/FT)
FRAME SECTION

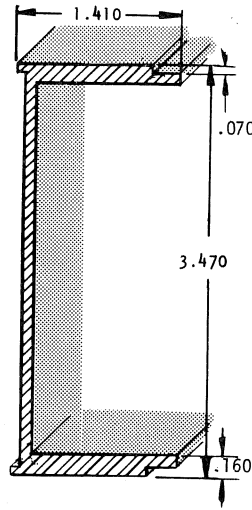

251-1170-00
 6063-T6
 CC: J /LB
 (.802 LB/FT)
FRAME SECTION

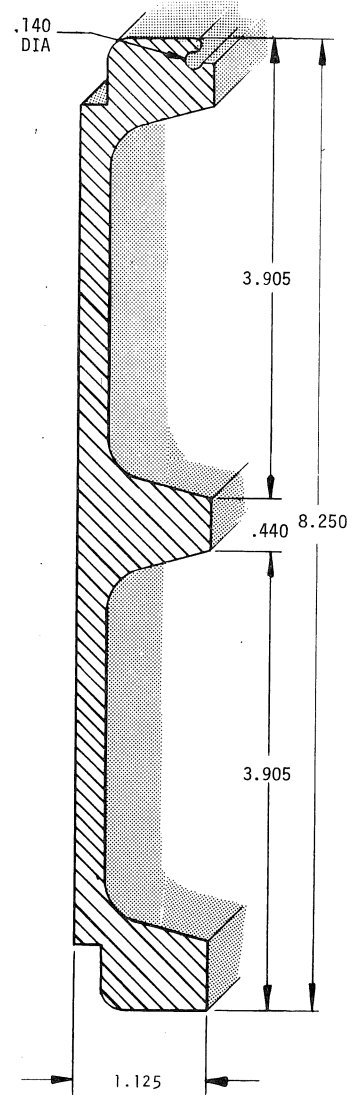

251-1138-00
 6063-T6
 CC: I-/LB
 (4.352 LB/FT)
FRAME SECTION

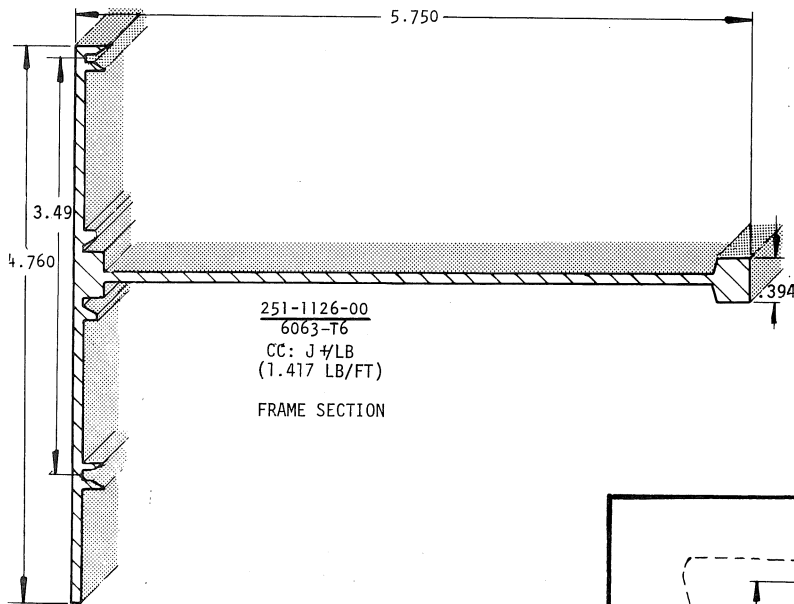

251-1126-00
 6063-T6
 CC: J+/LB
 (1.417 LB/FT)
FRAME SECTION

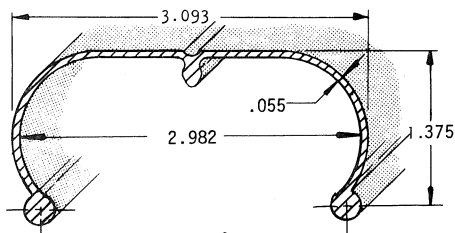

251-0198-00
 6063-T6
 CC: I /LB
 (.576 LB/FT)
BATTERY BOX

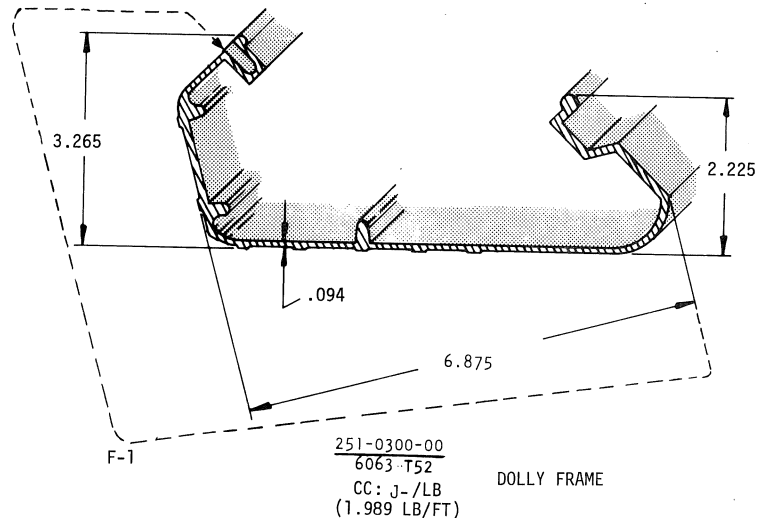

F-1
 251-0300-00
 6063-T52
 CC: J-/LB
 (1.989 LB/FT)
DOLLY FRAME

6

* ALUMINUM EXTRUSION (CONT)

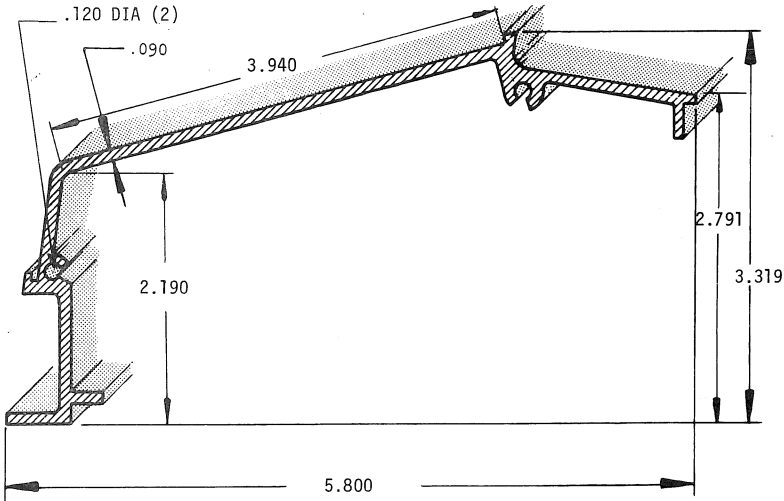

FRAME SECTION
 251-1034-00
 6063-T6
 CC: J+/LB (1.087 LB/FT)

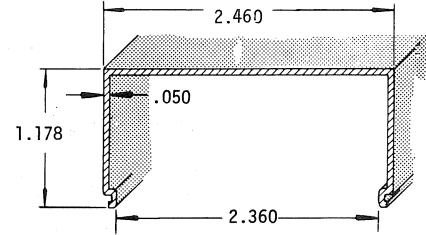

251-1370-00
 6063-T6
 CC: J+/LB
 (.281 LB/FT)
 WRAPAROUND

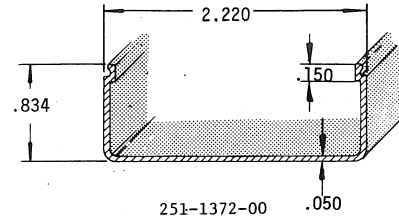

WRAPAROUND
 251-1372-00
 6063-T6
 CC: J+/LB
 (.208 LB/FT)

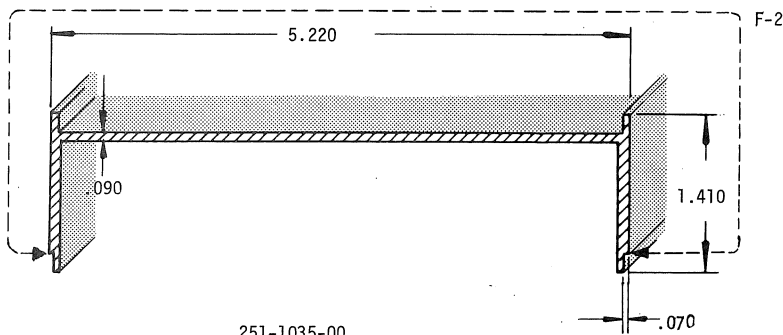

251-1035-00
 6063-T6
 CC: K- /LB
 (1.012 LB/FT)
 FRAME SECTION

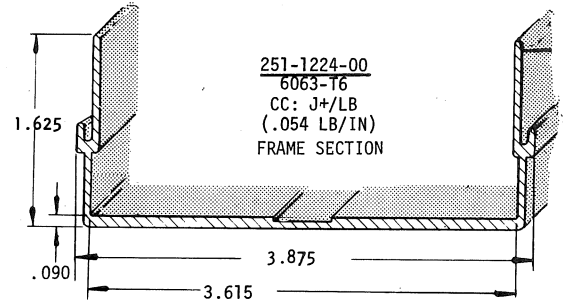

251-1224-00
 6063-T6
 CC: J+/LB
 (.054 LB/IN)
 FRAME SECTION

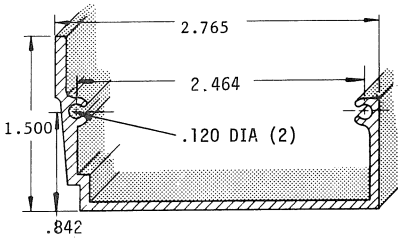

251-1203-00
 6063-T6
 CC: J+/LB
 (.528 LB/FT)
 FRAME SECTION

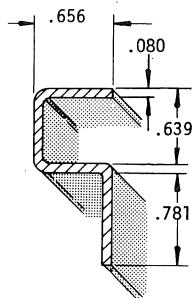

251-1465-00
 6063-T6
 CC: J-/LB
 (.240 LB/FT)
 TRIM

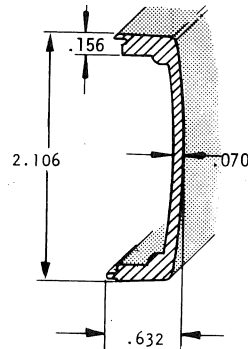

COVER
 251-0258-00
 6061-T6
 CC: J+/LB (.333 LB/FT)

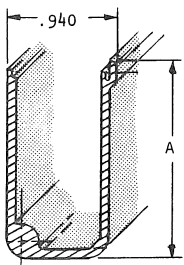

PN	A	CC
251-0160-00	1.350	I /LB (.332 LB/FT)
251-0156-00	1.629	K /LB (.382 LB/FT)
251-0161-00	1.969	J+/LB (.431 LB/FT)

6063-T5

PLUG-IN EXT. COVER

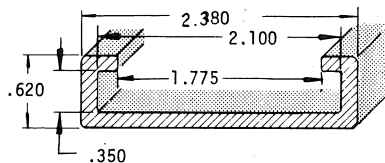

251-1397-00
 6063-T6
 CC: J+/LB
 (.612 LB/FT)
 BRACKET

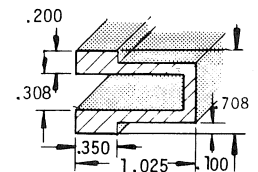

251-1150-00
 6063-T6
 CC: J+/LB
 (.376 LB/FT)
 LATCH, HOUSING

*FOR MECHANICAL PROPERTIES & TOLERANCES, SEE PAGES 6-43 THRU 6-48.

* ALUMINUM EXTRUSION (CONT)

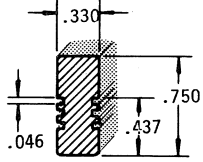

251-1449-00
6063-T6
CC: K /LB
(.282 LB/FT)
HANDLE

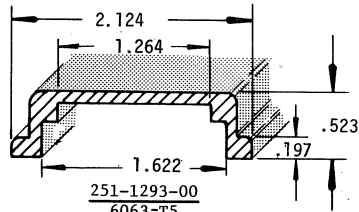

251-1293-00
6063-T5
CC: I+/LB
(.378 LB/FT)
SHIELD

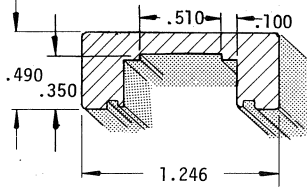

251-1375-00
6063-T6
CC: K /FT
(.450 LB/FT)
HOUSING

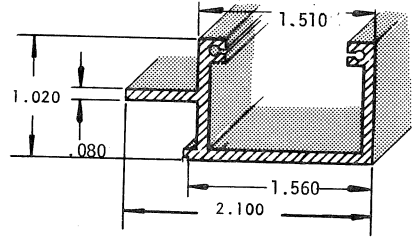

251-1158-00
6063-T6
CC: J+/LB
(.407 LB/FT)
FRAME SECTION

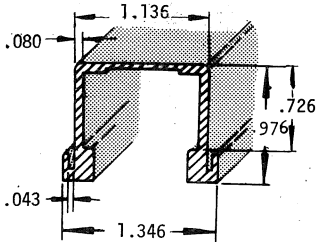

251-1161-00
6063-T6
CC: K-/LB
(.342 LB/FT)
COVER BRACKET

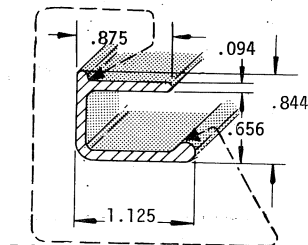

F-2
251-1424-00
6063-T6
CC: J /LB (.300 LB/FT)
HANDLE
F-0 FINISH EXCEPT AS NOTED

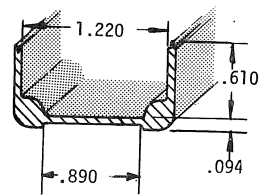

251-1117-00
6063-T6
CC: J+/LB (.283 LB/FT)
CHANNEL SHIELD

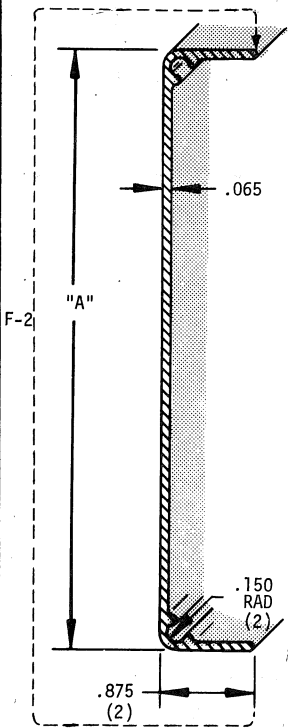

F-2
251-1490-00
6063-T6
CC: K /LB
(.595 LB/FT)
"A" DIM. 5.700
251-1491-00
6063-T6
CC: J /LB
(.556 LB/FT)
"A" DIM. 5.200
FRAME SECTION

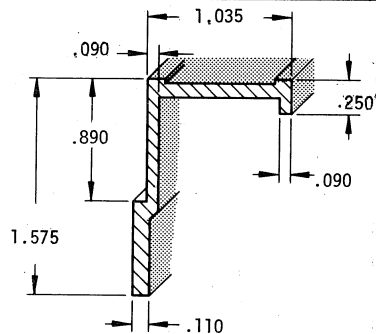

251-1500-00
6063-T6
CC: K-/LB (.336 LB/FT)
HANDLE

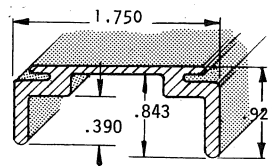

251-0115-00
6063-T6
CC: J /LB
(.466 LB/FT)
HANDLE BAR

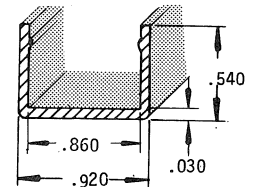

251-1209-00
6063-T6
CC: H /FT
(.066 LB/FT)
CAM, SWITCH COVER

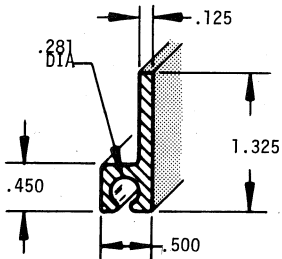

251-1531-00
6063-T6
CC: J+/LB
(.29 LB/FT)
FRAME SECTION

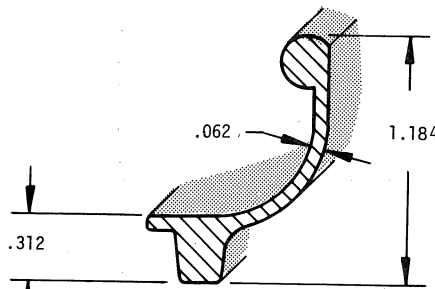

251-0083-00
6063-T6
CC: H-/LB
FRAME SECTION

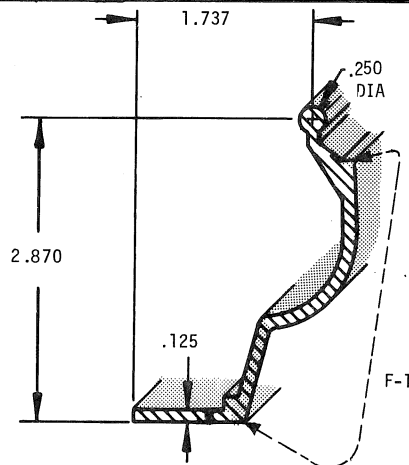

251-1530-00
6063-T6
CC: J+/LB (.718 LB/FT)
FRAME SECTION
F-0 FINISH EXCEPT AS NOTED

6

* ALUMINUM EXTRUSION (CONT)

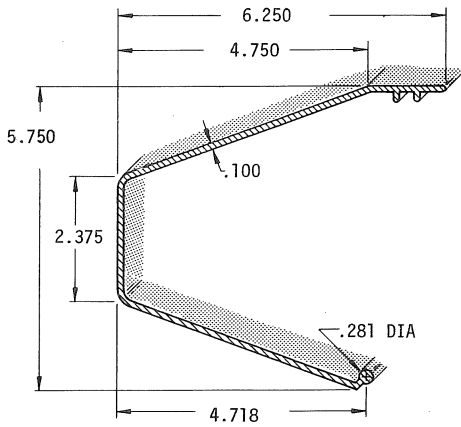

251-1517-00
6063-T6
CC: J /LB (.2 LB/FT)
CABINET FRONT

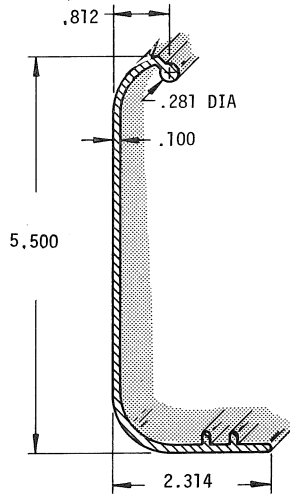

251-1518-00
6063-T6
CC: J-/LB (1.04 LB/FT)
FRAME SECTION

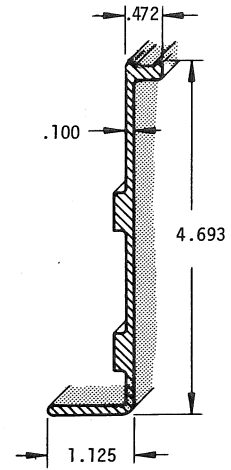

251-1515-00
6063-T6
CC: J-/LB (.650 LB/FT)
FRAME SECTION

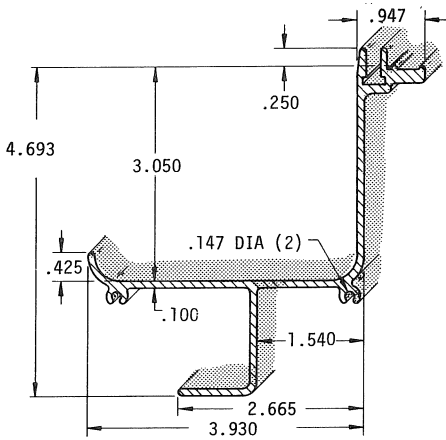

251-1514-00
6063-T6
CC: J /LB (.100 LB/FT)
FRAME SECTION

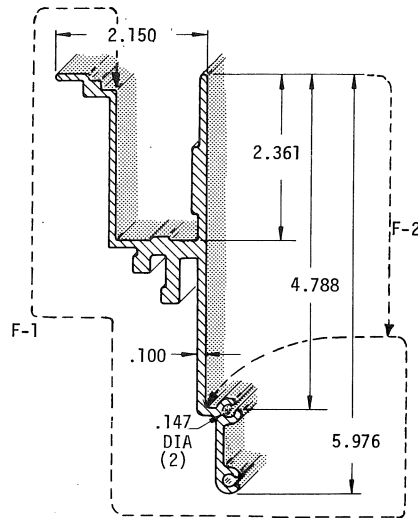

251-1519-00
6063-T6
CC: J /LB (.85 LB/FT)
SUPPORT

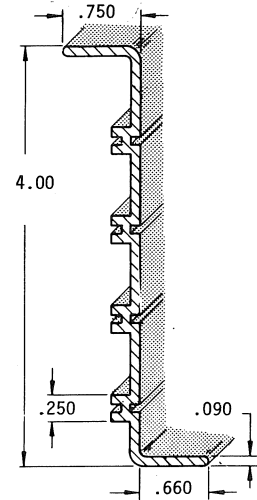

251-1529-00
6063-T6
CC: J /LB (.60 LB/FT)
FRAME SECTION

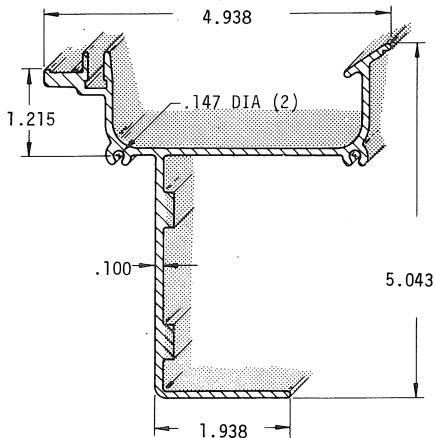

251-1521-00
6063-T6
CC: J /LB (1.200 LB/FT)
FRAME SECTION

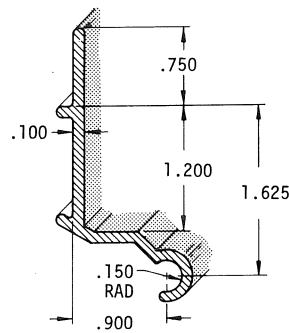

251-1520-00
6063-T6
CC: J-/LB (.25 LB/FT)
BASE HINGE

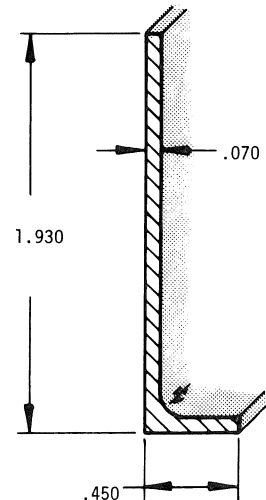

251-1478-00
6063-T6
CC: J+/LB
(.33 LB/FT)

* ALUMINUM EXTRUSION (CONT)

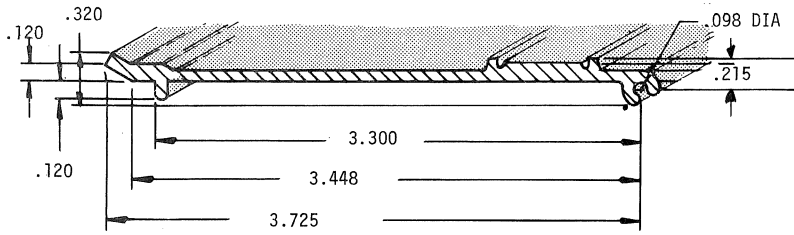

251-1554-00
6063-T6
CC: J /LB (.533 LB/FT)
COVER, STORAGE COMP.

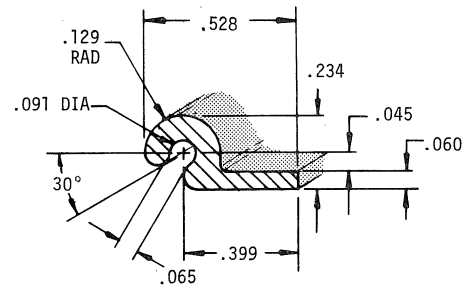

251-1553-00
6063-T6
CC: J+/LB (.064 LB/FT)
HINGE

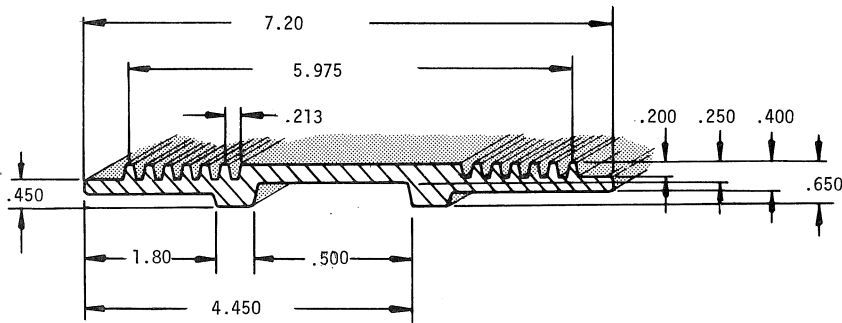

251-1589-00
6063-T6
CC: J-/LB (2.758 LB/FT)
HEAT SINK

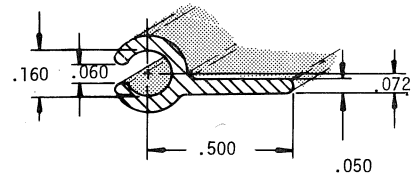

251-1593-00
6063-T6
CC: J+/LB (.056 LB/FT)
BRACKET

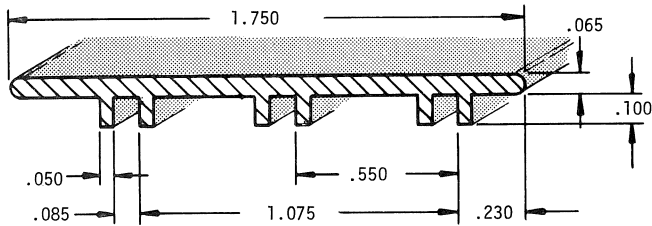

251-1565-00
6063-T6
CC: J /LB (.172 LB/FT)
GUIDE

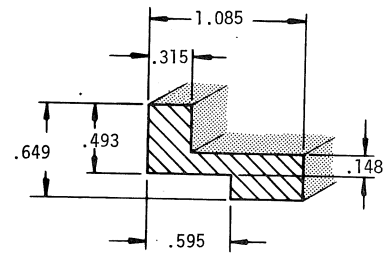

251-1560-00
6063-T6
CC: J/LB
PIVOT

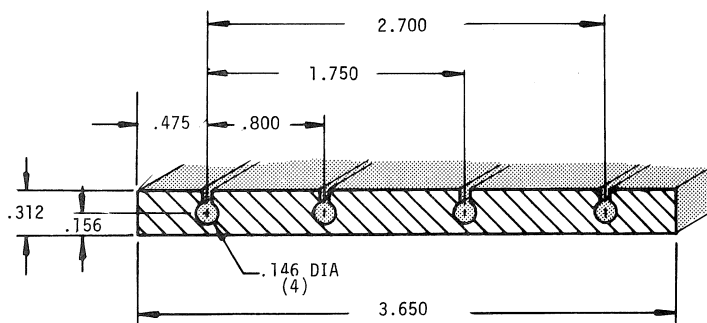

251-1599-00
6063-T6
CC: J+/LB (1.195 LB/FT)
HEAT SINK

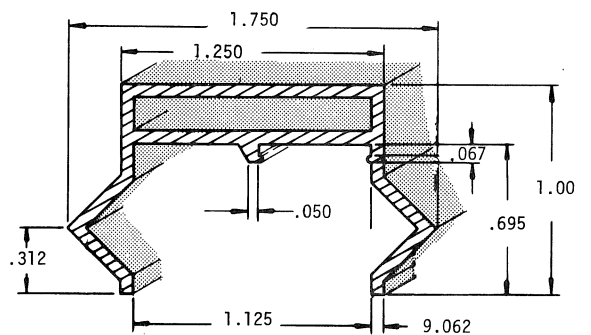

251-1573-01
6063-T6
CC: K-/LB (.354 LB/FT)
RAIL, CARRIAGE

6

* ALUMINUM EXTRUSION (CONT)

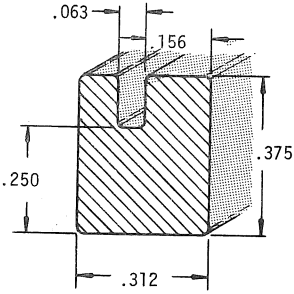

251-1606-00
6063-T6
CC: J/LB (.123 LB/FT or
SUPPORT BAR 1.476 LB/12')

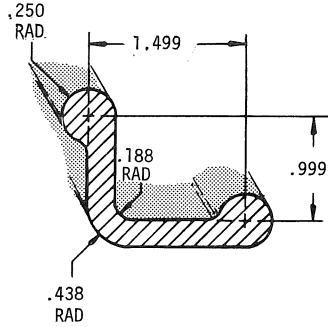

251-1567-00
6061-T6511
CC: J-/LB (1.07 LB/FT)
FRAME BASE

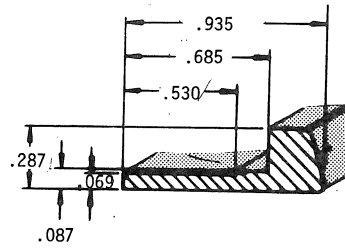

251-1615-00
6063-T6
CC: J+/LB (.330 LB/FT)
RETAINER PLUG-IN

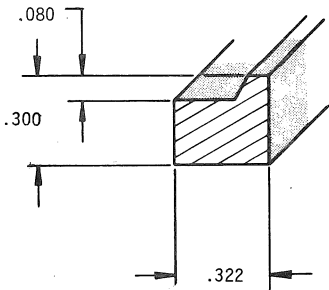

251-1605-00
6063-T6
CC: J+/LB (.095 LB/FT)

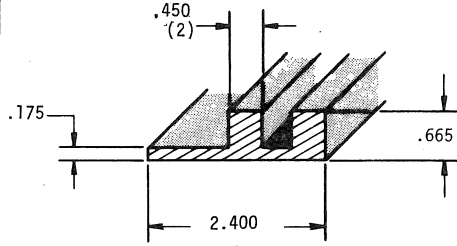

251-1706-00
6063-T6
CC: J /LB (1.033 LB/FT)
HEAT SINK

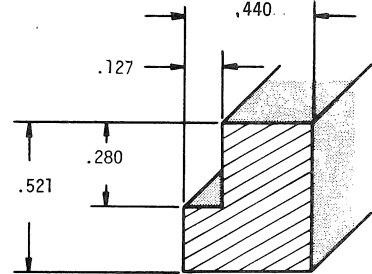

251-1480-00
6063-T6
CC: K /LB (.221 LB/FT)

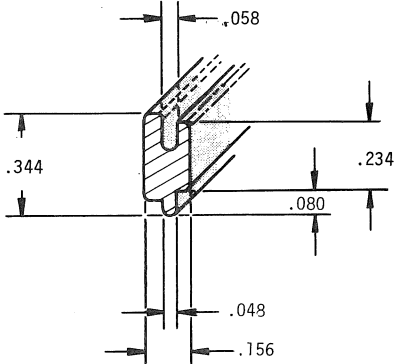

251-1476-00
6063-T6
CC: K /LB (.120 LB/FT)

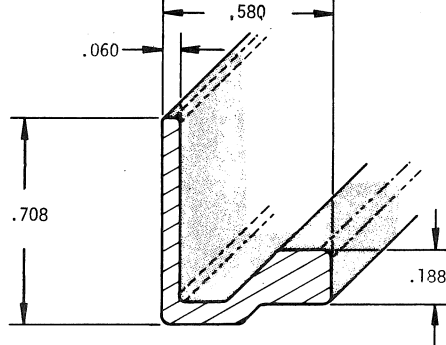

251-1475-00
6063-T6
CC: K /LB
(.200 LB/FT)

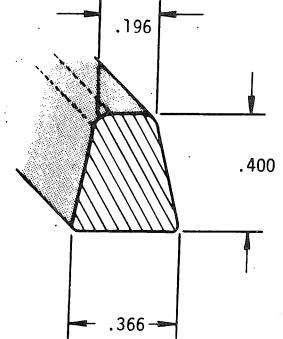

251-1635-00
6061-T6
CC: K-/LB
(.1344 LB/FT)

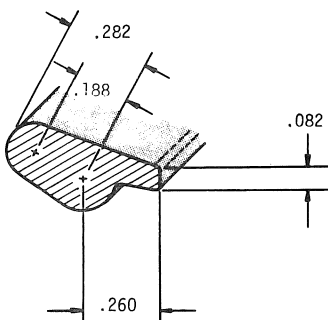

251-1707-00
6063-T6
CC: J+/LB (.110 LB/FT)

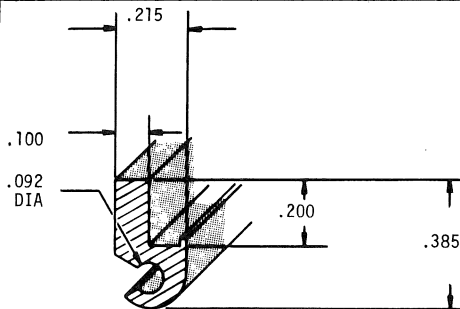

251-1691-00
6063-T6
CC: K-/LB

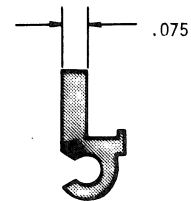

251-1691-01
6063-T6
CC: K+/LB
(.055 LB/FT)

* ALUMINUM EXTRUSION (CONT)

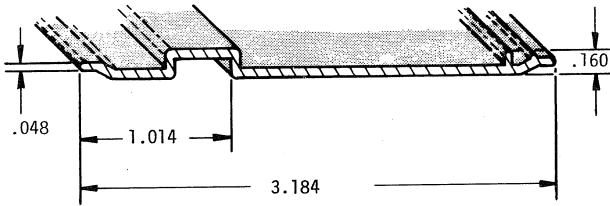

251-1600-00
6063-T6
CC: J /LB (.263 LB/FT)

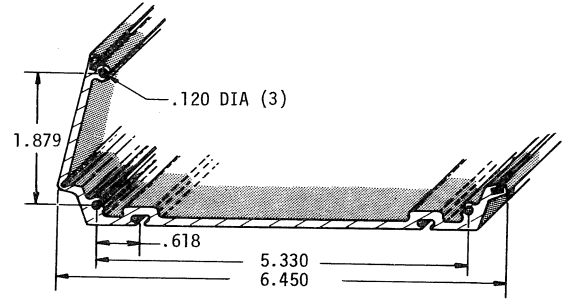

251-1532-00
6063-T6
CC: J+/LB (.200 LB/FT)

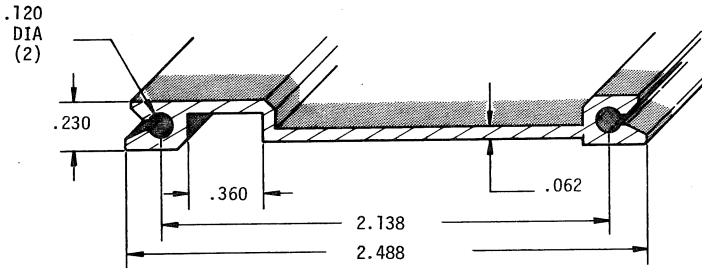

251-1630-00
6063-T6
CC: J+/LB (.262 LB/FT)

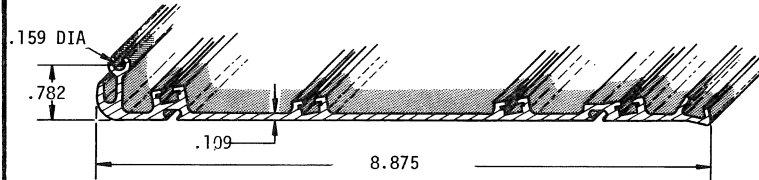

251-1501-01
CC: J /LB (2.000 LB/FT)
6063-T6

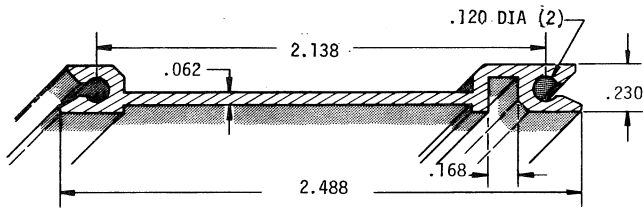

251-1629-00
6063-T6
CC: J+/LB (.262 LB/FT)

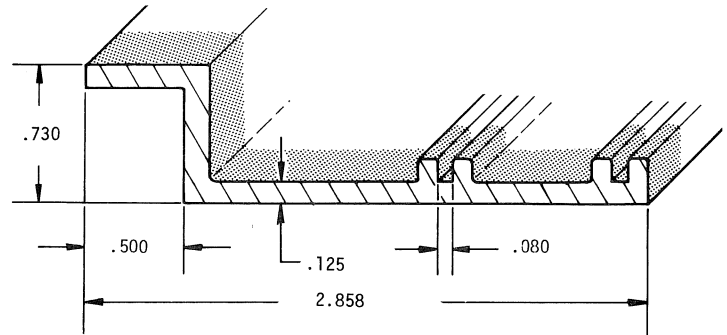

251-1575-00
6063-T6
CC: J-/LB (1.578 LB/FT)
F-1 FINISH

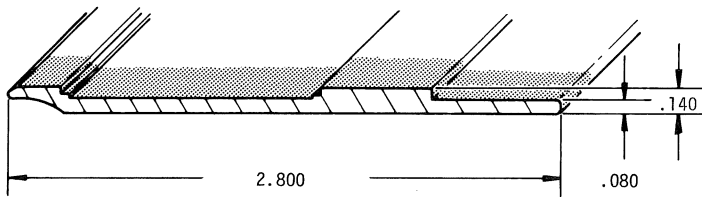

251-1585-00
6061-T6
CC: J+/LB (.271 LB/FT)
F-2 FINISH

COST CODE (CC COLUMN)

CODE	A	B	C	D	E	F	G	H	I	J	K	L	M	N	O
≈ VALUE with +	.75¢	2¢	3.75¢	6¢	10¢	18¢	35¢	60¢	\$1	\$2	\$3.75	\$6	\$10	\$18	\$35+
≈ VALUE no suffix	.5¢	1.5¢	3¢	5¢	8¢	15¢	25¢	50¢	75¢	\$1.50	\$3	\$5	\$8	\$15	\$25
≈ VALUE with -	.2¢	1.25¢	2.5¢	4.25¢	7¢	13¢	22¢	40¢	65¢	\$1.25	\$2.50	\$4.25	\$7	\$13	\$22

NOTE: Costs may vary from order to order due to order quantities, vendor, etc.

6

* ALUMINUM EXTRUSION (CONT)

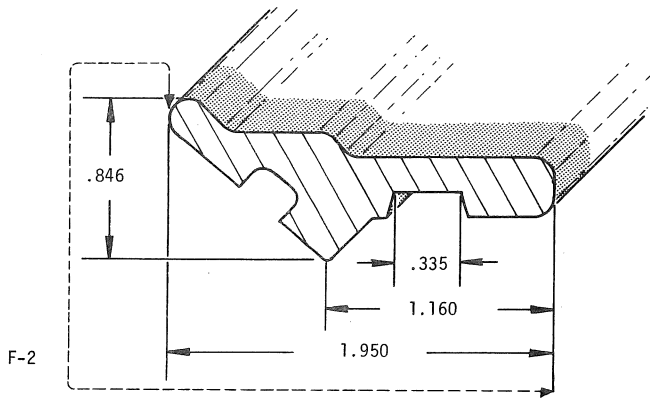

251-1577-00
6063-T6
CC: J+/LB (.720 LB/FT)

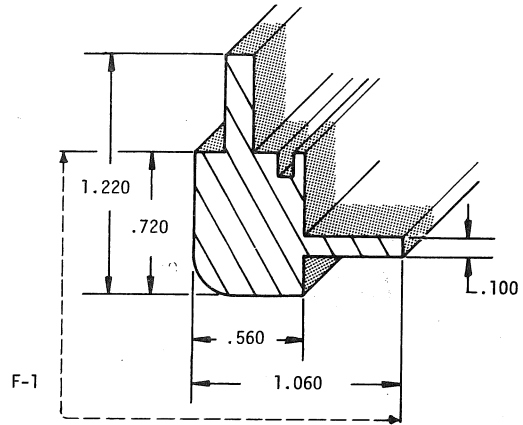

251-1699-00
6063-T6
CC: K/LB (.605 LB/FT)

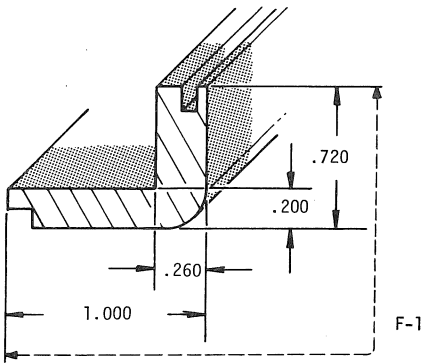

251-1700-00
6063-T6
CC: K/LB (.305 LB/FT)

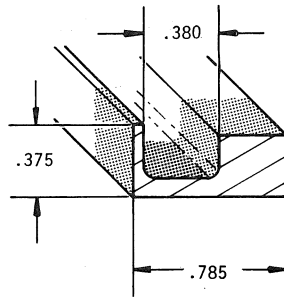

251-1672-00
6063-T6
CC: L/LB (.200 LB/FT)
F-1 FINISH

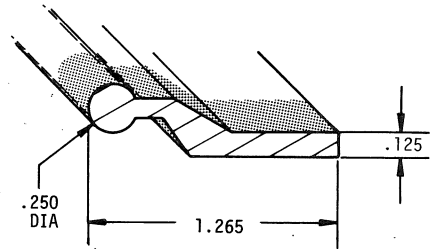

251-1631-00
6063-T6
CC: J+/LB (.270 LB/FT)
F-0 FINISH

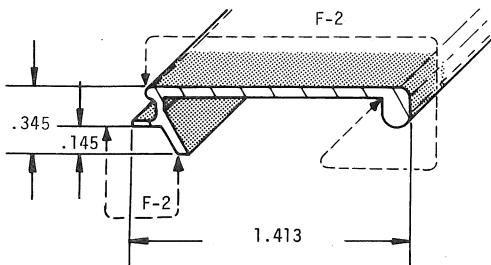

251-1021-01
6063-T6
CC: J+/LB (.120 LB/FT)
F-1 FINISH EXCEPT AS NOTED

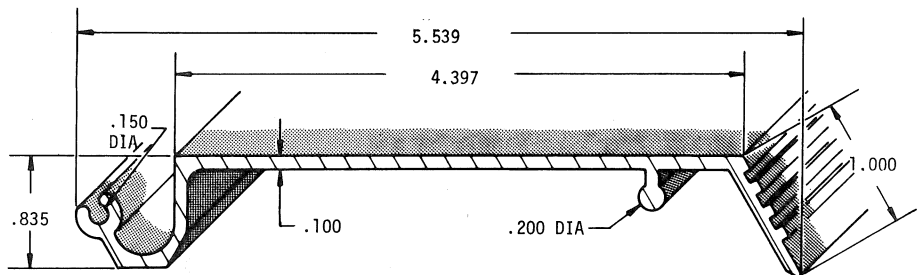

251-1574-00
6063-T6
CC: J+/LB (.799 LB/FT)

* ALUMINUM EXTRUSION (CONT)

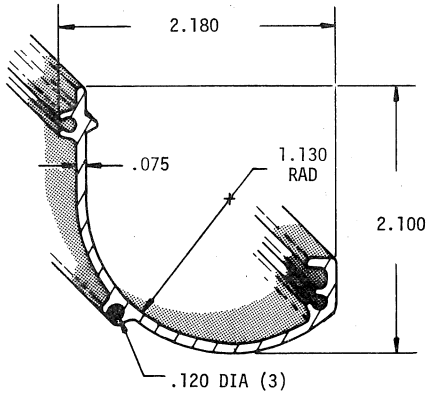

251-1584-00
6063-T6
CC: J /LB (.446 LB/FT)
F-1 FINISH

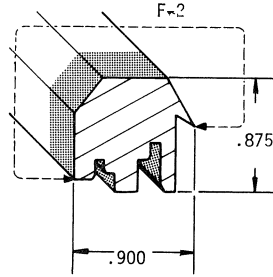

251-1671-00
6061-T6
CC: K+/LB (1.046 LB/FT)

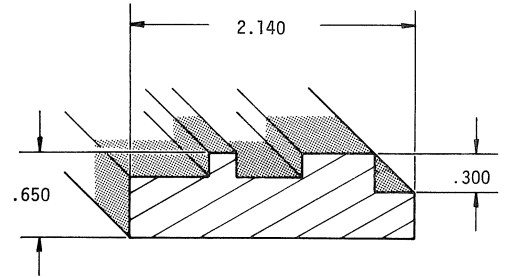

251-1673-00
6063-T6
CC: K /LB (1.208 LB/FT)
F-0 FINISH

6

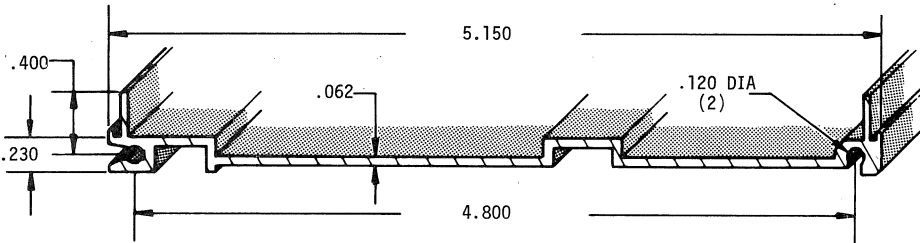

251-1453-00
6063-T6
CC: J+/LB (.650 LB/FT)
F-1 FINISH

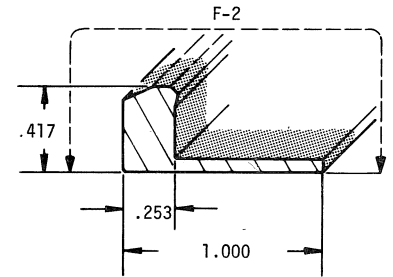

251-1581-00
6063-T6
CC: J+/LB
F-0 FINISH EXCEPT AS NOTED

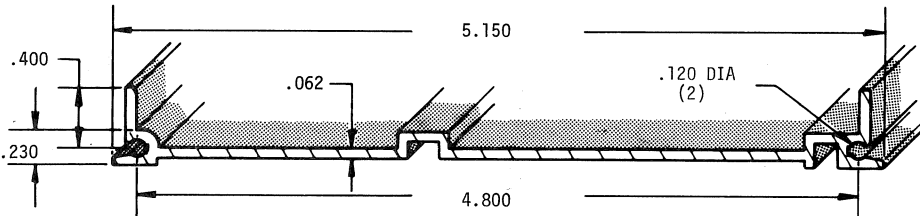

251-1452-00
6063-T6
CC: K-/LB (.650 LB/FT)
F-1 FINISH

COST CODE (CC COLUMN)

CODE	≈ VALUE with -	≈ VALUE no suffix	≈ VALUE with +
A	.2¢	.5¢	.75¢
B	1.25¢	1.5¢	2¢
C	2.5¢	3¢	3.75¢
D	4.25¢	5¢	6¢
E	7¢	8¢	10¢
F	13¢	15¢	18¢
G	22¢	25¢	35¢
H	40¢	50¢	60¢
I	65¢	75¢	\$1
J	\$1.25	\$1.50	\$2
K	\$2.50	\$3	\$3.75
L	\$4.25	\$5	\$6
M	\$7	\$8	\$10
N	\$13	\$15	\$18
O	\$22	\$25	\$35+

NOTE: Costs may vary from order to order due to order quantities, vendor, etc.

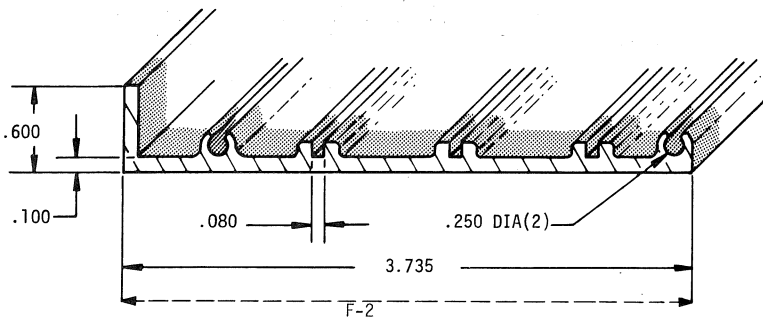

251-1576-00
6063-T6
CC: J /LB (.629 LB/FT)
F-1 FINISH EXCEPT AS NOTED

* ALUMINUM EXTRUSION (CONT)

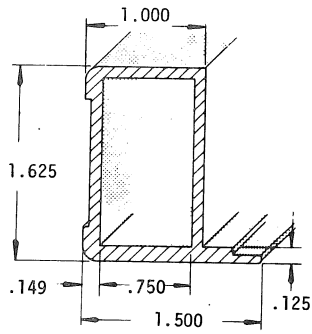

251-1464-00
6063-T6
CC: J-/LB (.750 LB/FT)

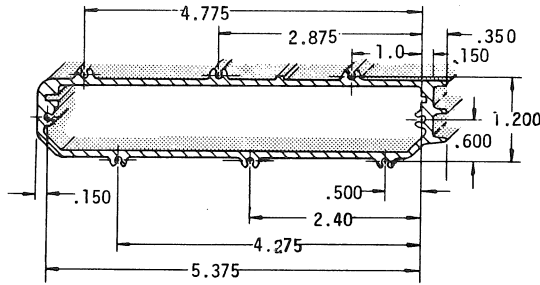

251-1456-02
6063-T5
CC: K-/LB (1.770 LB/FT)

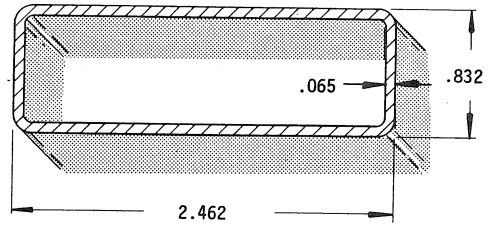

251-1330-00
6063-T6
CC: J+/LB
(.481 LB/FT)

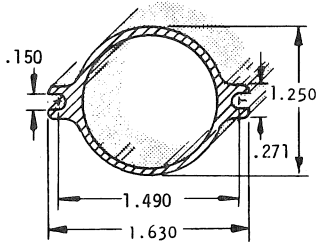

251-0106-00
6063-T6
CC: I+/LB (4.144 LB/FT)

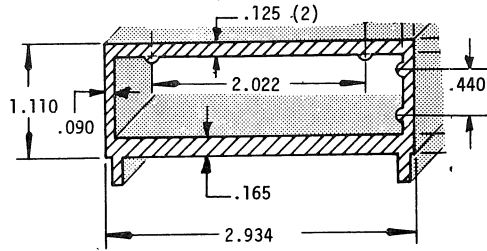

251-1269-00
6061-T6
CC: I/LB
(1.326 LB/FT)

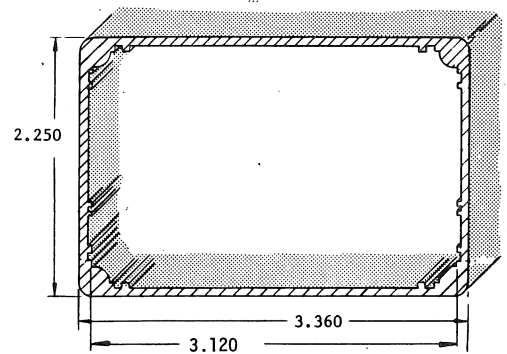

251-1259-00
6063-T6
CC: J+/LB
(.994 LB/FT)

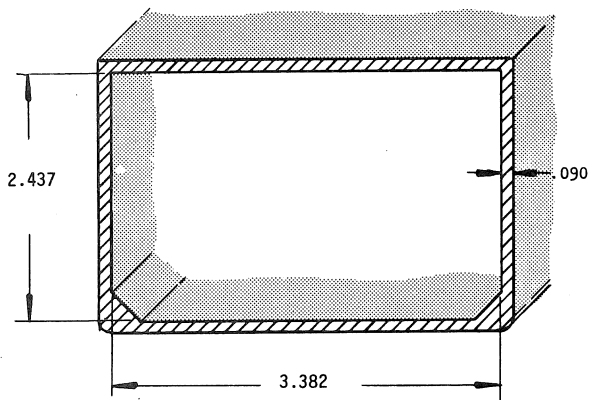

HOUSING
251-0120-00
6063-T5
CC: I+/LB (1.361 LB/FT)

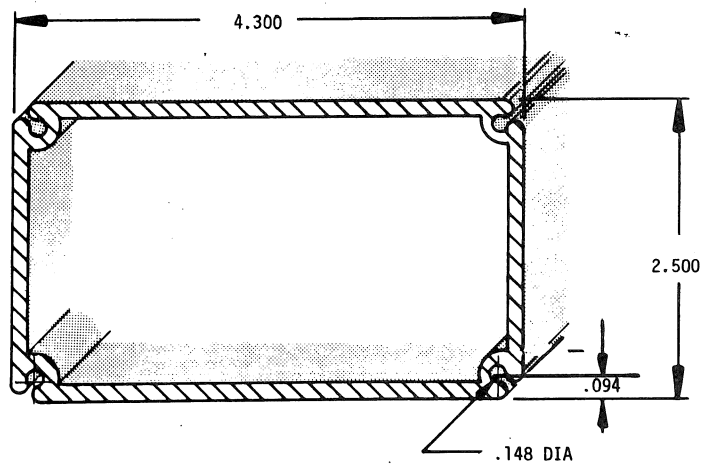

251-1070-00
6063-T6
CC: J+/LB (1.548 LB/FT)

* ALUMINUM EXTRUSION (CONT)

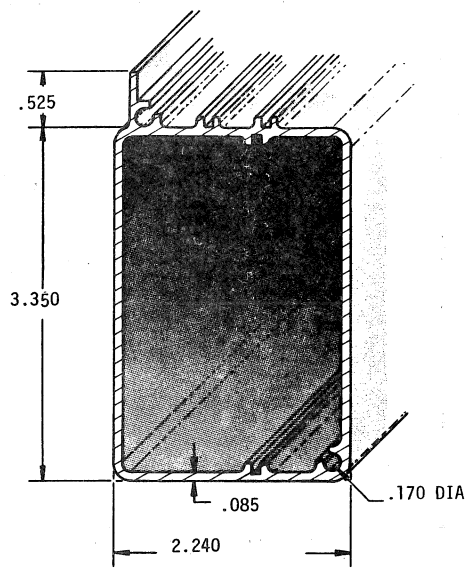

251-1538-00
6063-T6
CC: J+/LB (1.400 LB/FT)
OUTSIDE SURFACES F-1

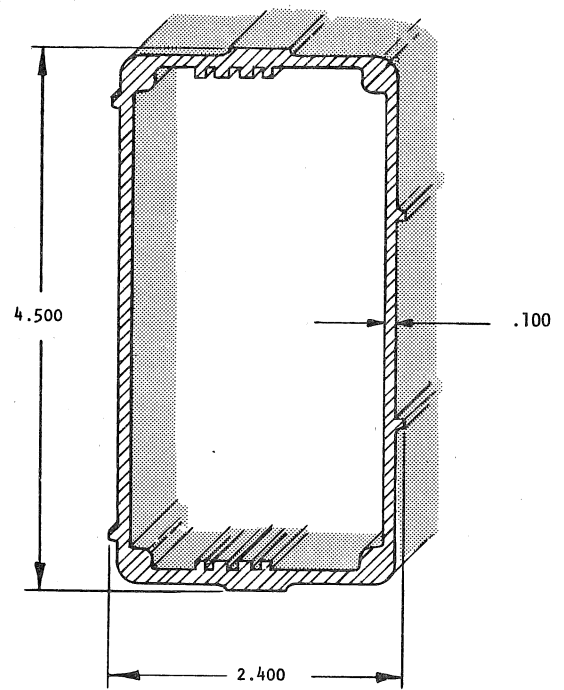

251-1231-00
6063-T6
CC: J+/LB
(1.857 LB/FT)

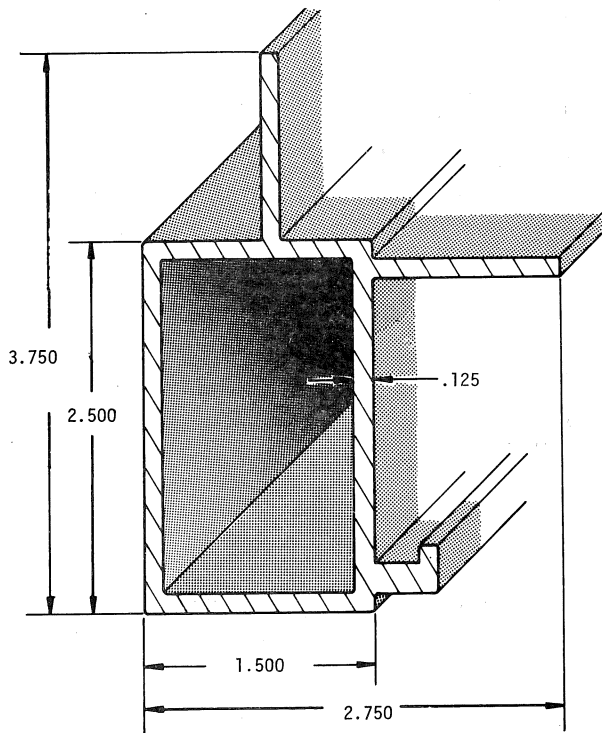

251-1685-00
6063-T6 J+/LB
F-1 FINISH ON ALL OUTSIDE SURFACES

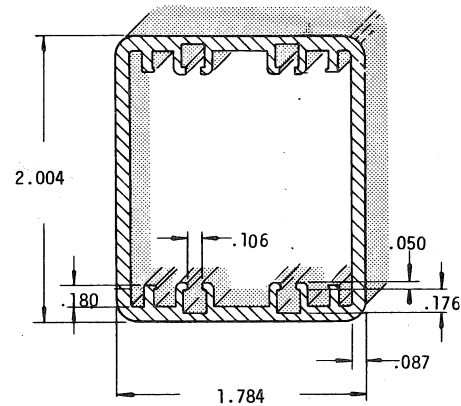

251-1015-00 3.000 long CC: K / EA
251-1015-01 12.000 long CC: N / LB
6063-T6 (.785 LB/FT)

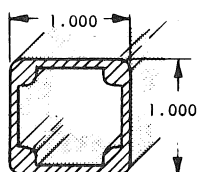

251-0061-00
6063-T6
CC: J+/LB (.750 LB/FT)
CHOPPER BODY

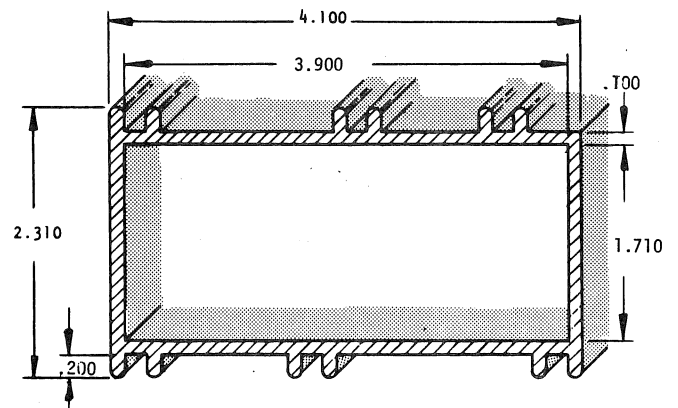

251-1068-00
6063-T6
CC: J+/LB (1.668 LB/FT)

6

* ALUMINUM EXTRUSION (CONT)

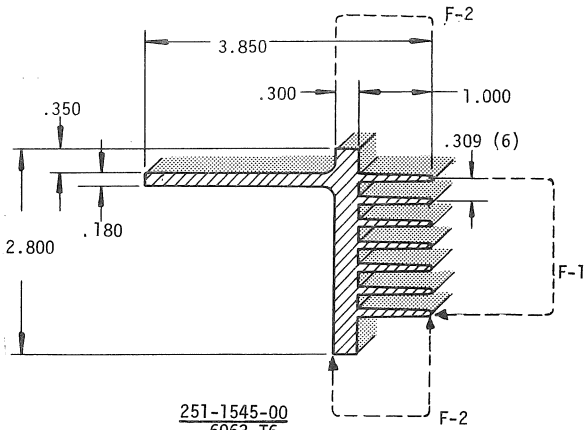

251-1545-00
6063-T6
CC: J-/LB (2.198 LB/FT)
HEAT SINK

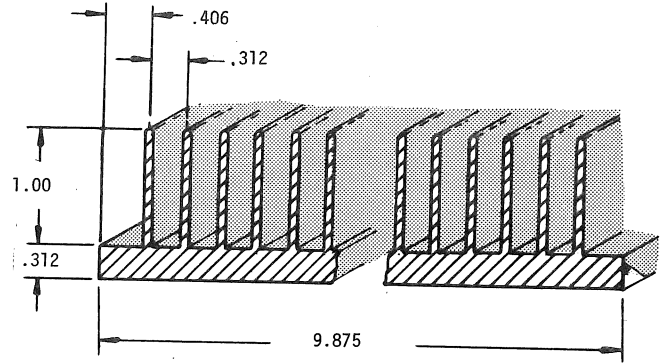

251-1591-00
6063-T6
CC: M+/FT
HEAT SINK

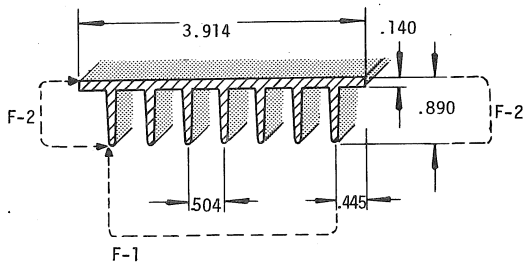

251-1549-00
6063-T6
CC: J /LB (1.368 LB/FT)
HEAT SINK

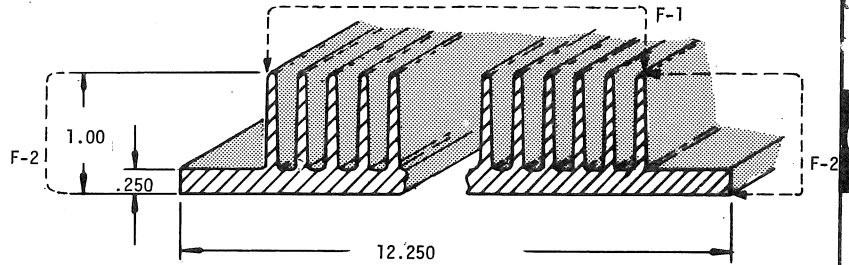

251-1588-00
6063-T6
CC: M+/FT
HEAT SINK

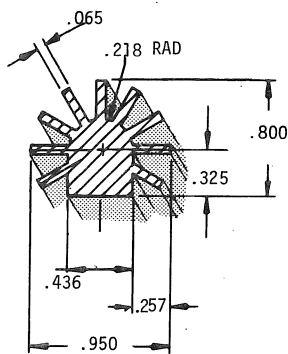

251-1580-00
6063-T6
CC: K-/LB
HEAT SINK
(.443 LB/FT)
F-0 FINISH ALL OVER

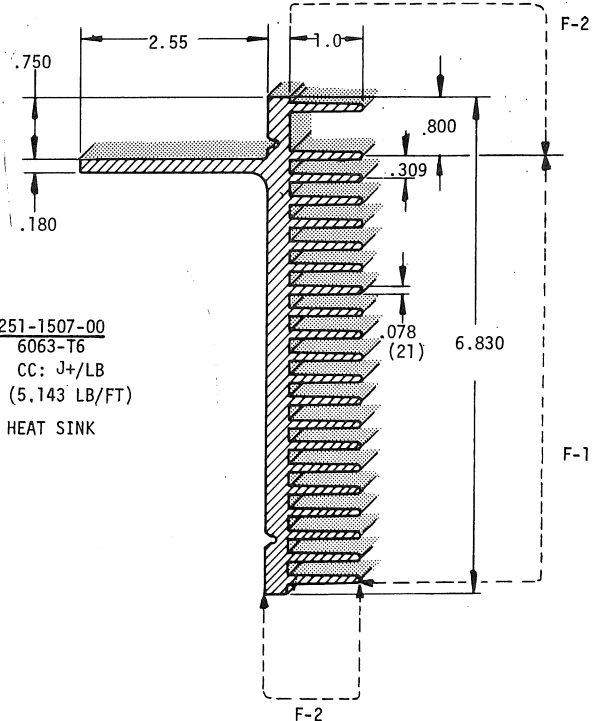

251-1507-00
6063-T6
CC: J+/LB
(5.143 LB/FT)
HEAT SINK

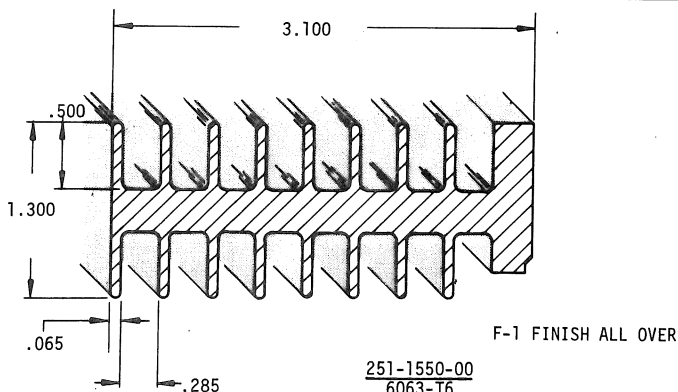

251-1550-00
6063-T6
CC: J-/LB
HEAT SINK
(2.04 LB/FT)

*FOR MECHANICAL PROPERTIES & TOLERANCES, SEE PAGES 6-43 THRU 6-48.

* ALUMINUM EXTRUSION (CONT)

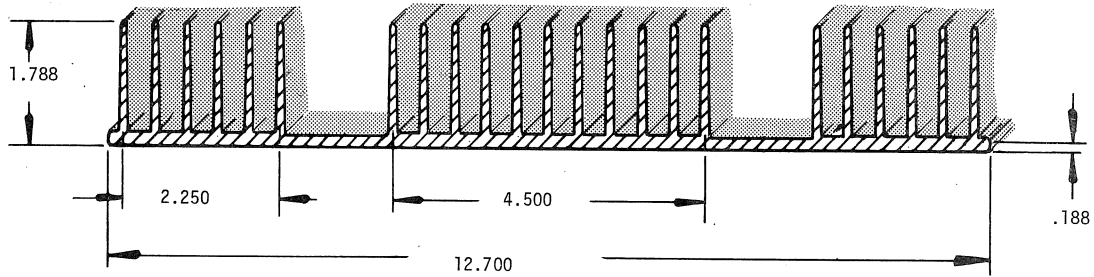

251-1366-00
6063-T6
CC: J-/LB (7.987 LB/FT)
HEAT SINK

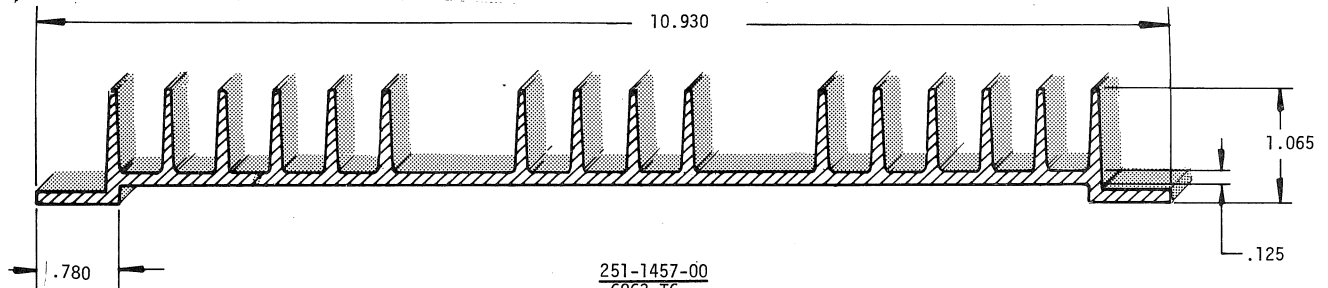

251-1457-00
6063-T6
CC: J-/LB
(2.95 LB/FT)
HEAT SINK

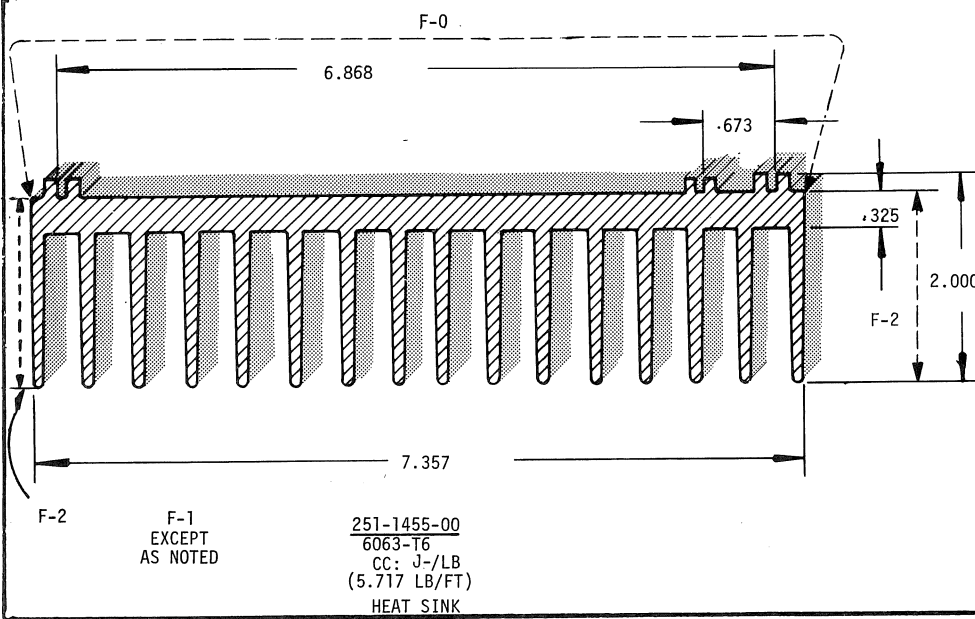

F-1
EXCEPT
AS NOTED

251-1455-00
6063-T6
CC: J-/LB
(5.717 LB/FT)
HEAT SINK

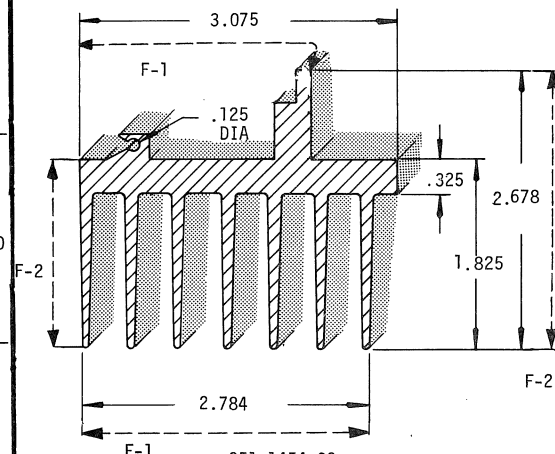

251-1454-00
6063-T6
CC: J-/LB
(2.744 LB/FT)
HEAT SINK

COST CODE

(CC COLUMN)

CODE	A	B	C	D	E	F	G	H	I	J	K	L	M	N	O
≈ VALUE with +	.75¢	2¢	3.75¢	6¢	10¢	18¢	35¢	60¢	\$1	\$2	\$3.75	\$6	\$10	\$18	\$35+
≈ VALUE no suffix	.5¢	1.5¢	3¢	5¢	8¢	15¢	25¢	50¢	75¢	\$1.50	\$3	\$5	\$8	\$15	\$25
≈ VALUE with -	.2¢	1.25¢	2.5¢	4.25¢	7¢	13¢	22¢	40¢	65¢	\$1.25	\$2.50	\$4.25	\$7	\$13	\$22

NOTE: Costs may vary from order to order due to order quantities, vendor, etc.

* ALUMINUM EXTRUSION (CONT)

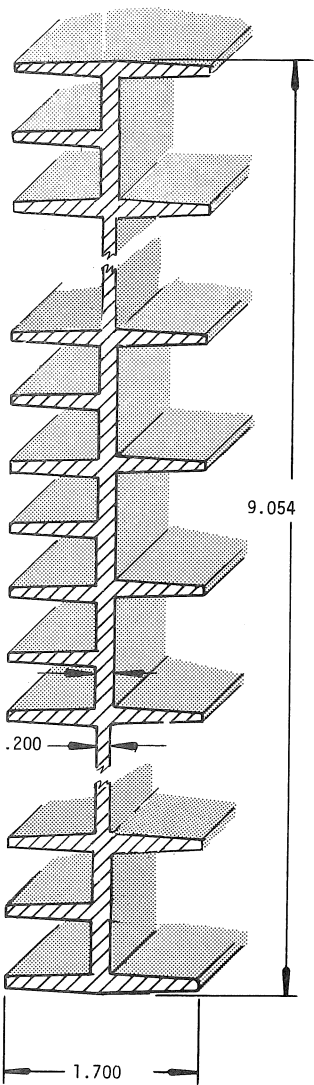

251-1093-00
6063-T6
CC: I-/LB
(3.671 LB/FT)
HEAT SINK

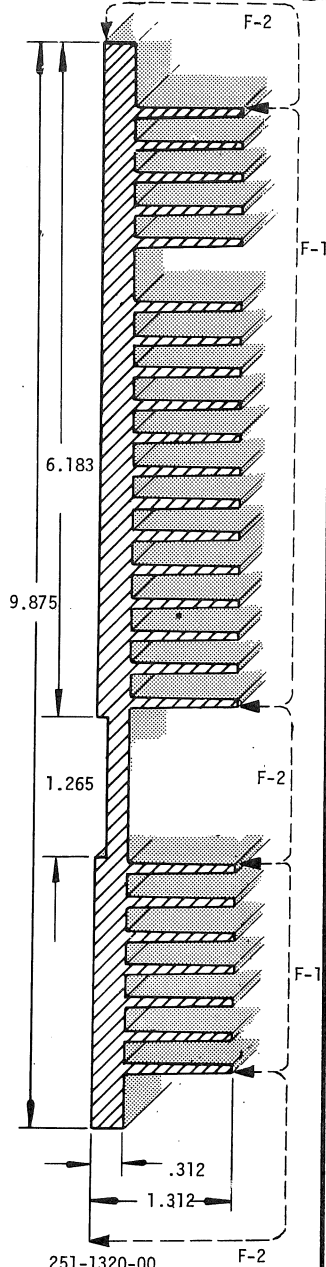

251-1320-00
6063-T6
CC: J-/LB
(5.657 LB/FT)
HEAT SINK

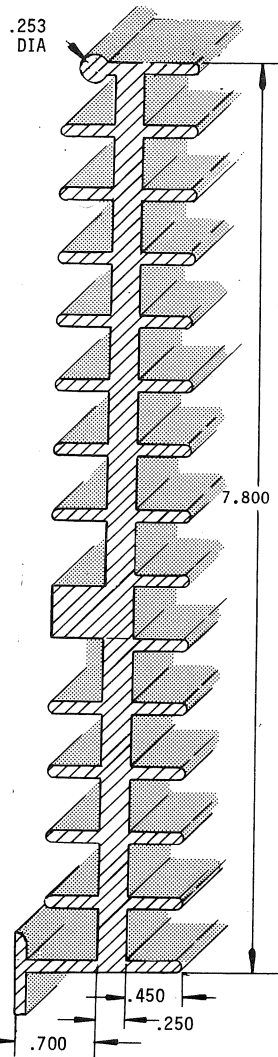

251-1061-00
6063-T6
CC: I/LB
(4.144 LB/FT)
HEAT SINK

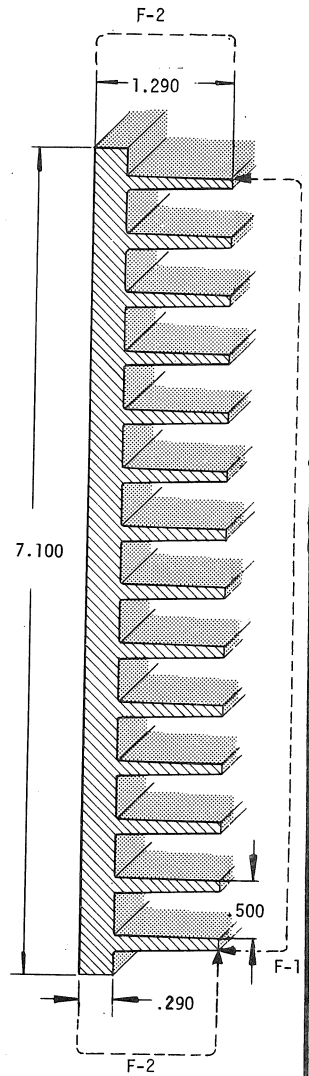

251-1377-00
6063-T6
CC: I+/LB
(4.615 LB/FT)
HEAT SINK

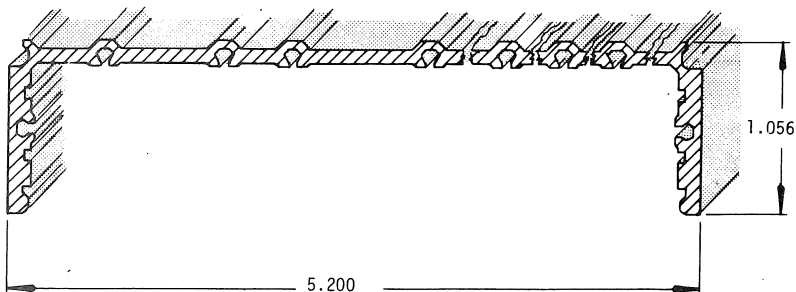

HEAT SINK
251-1326-00
6063-T6
CC: J/LB (.786 LB/FT)

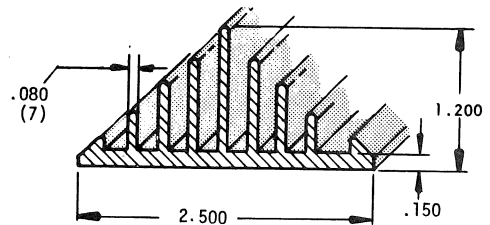

HEAT SINK
251-1122-00
6063-T6
CC: I/LB
(.904 LB/FT)

* ALUMINUM EXTRUSION (CONT)

6

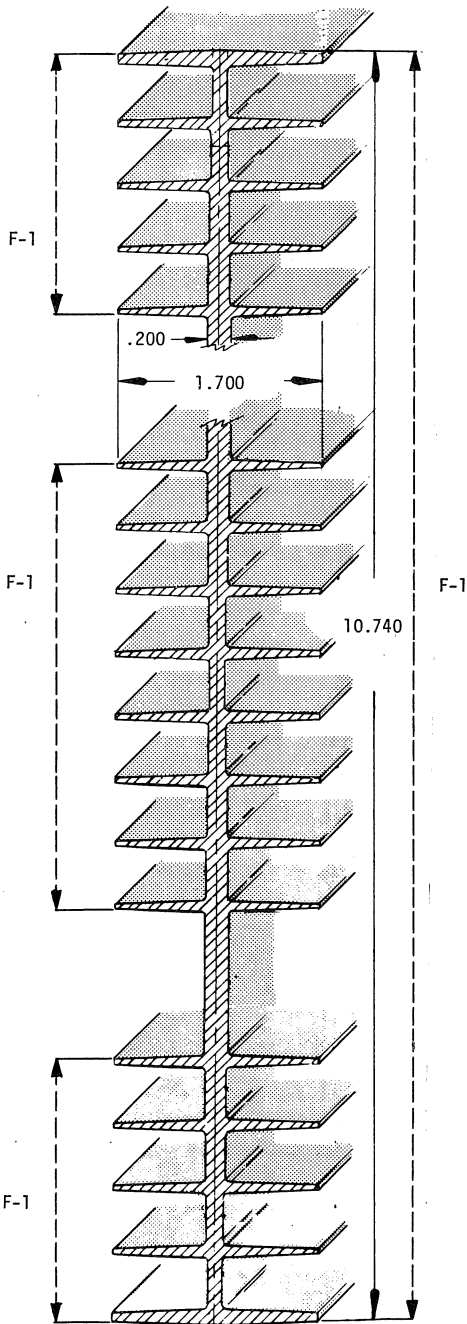

251-1048-00
6063-T5
CC: J-/LB (5.450 LB/FT)
F-2 FINISH EXCEPT AS NOTED
HEAT SINK

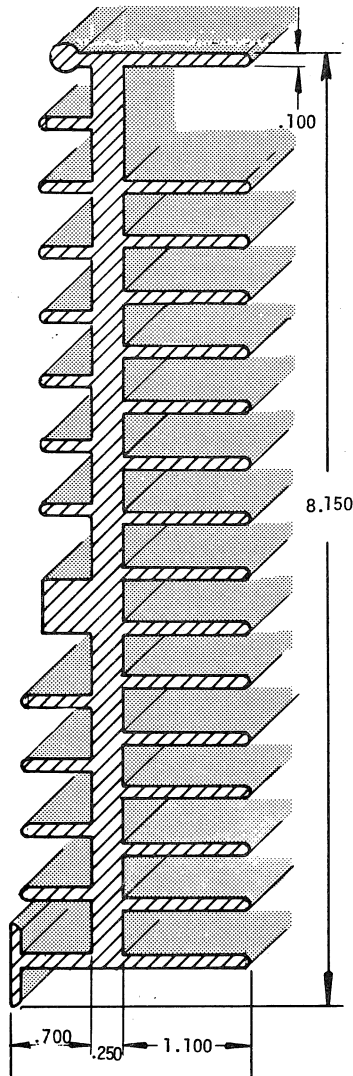

251-1110-00
6063-T6
CC: I /LB
HEAT SINK

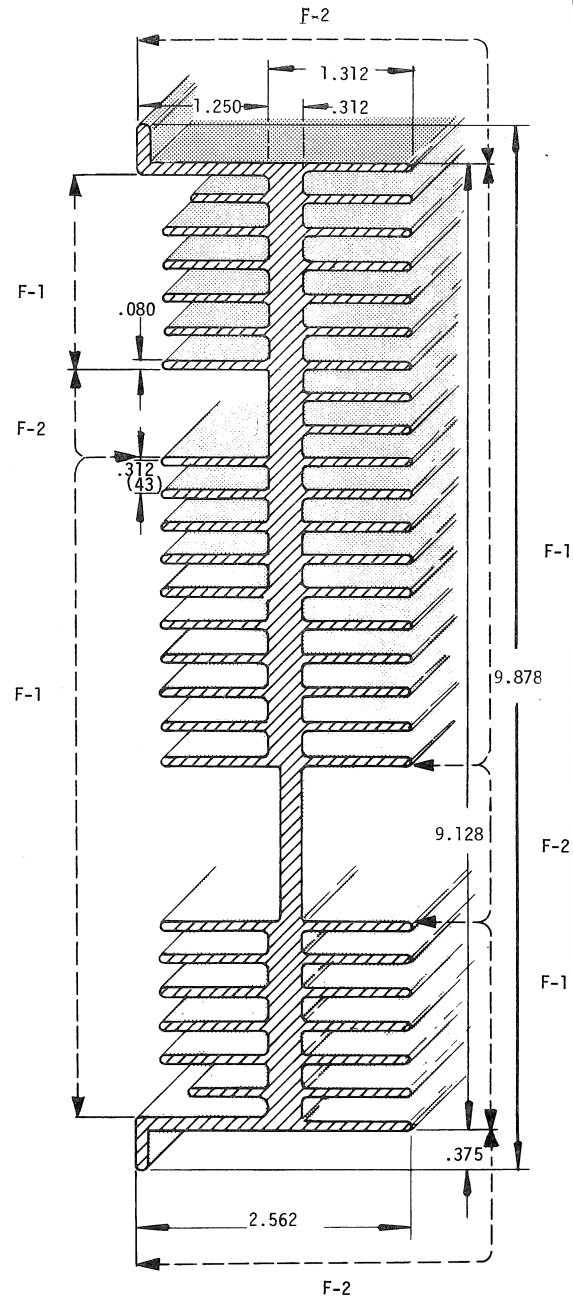

251-1433-00
6063-T5
CC: J /LB (8.436 LB/FT)
HEAT SINK

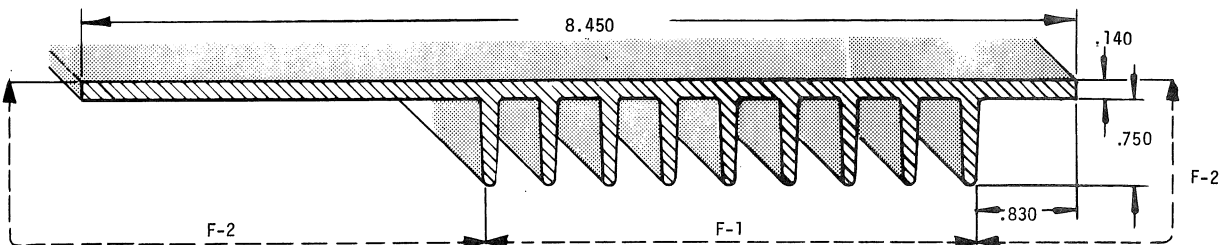

251-1220-00
6063-T6
CC: K-/LB (2.326 LB/FT)
HEAT SINK

* ALUMINUM EXTRUSION (CONT)

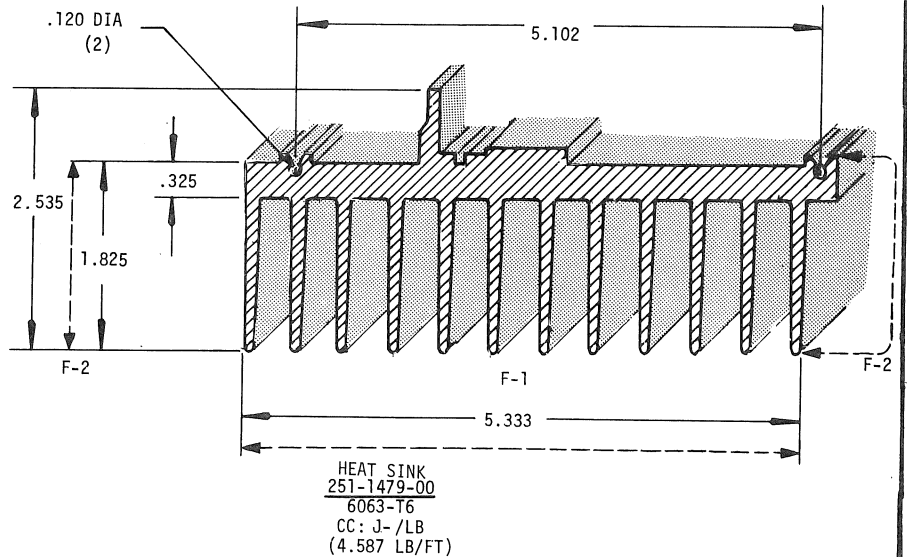
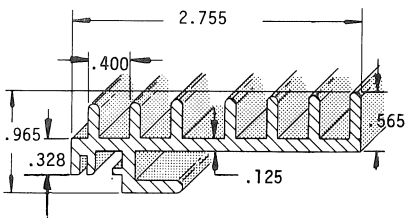
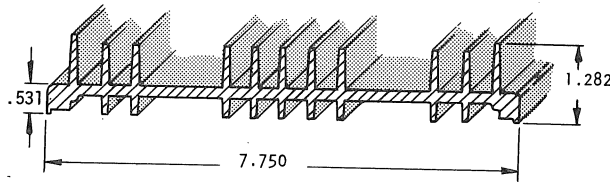
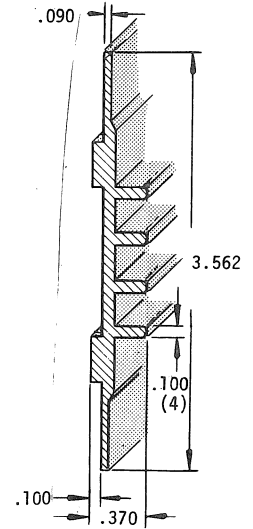
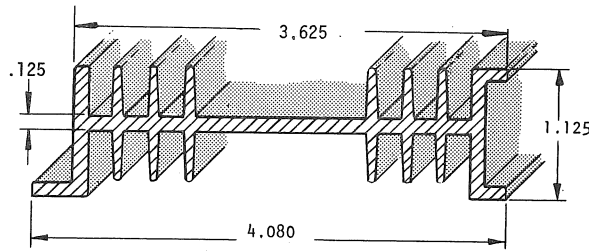
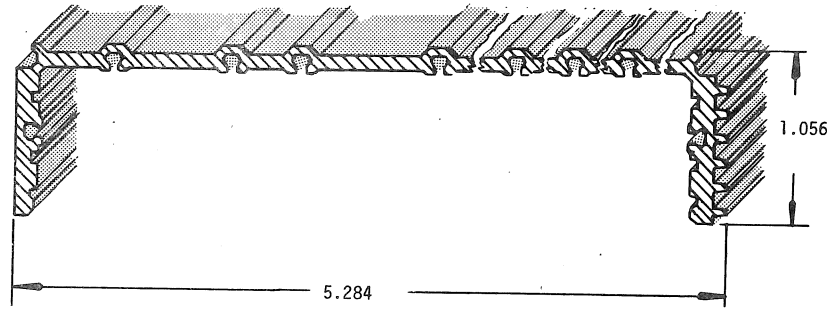
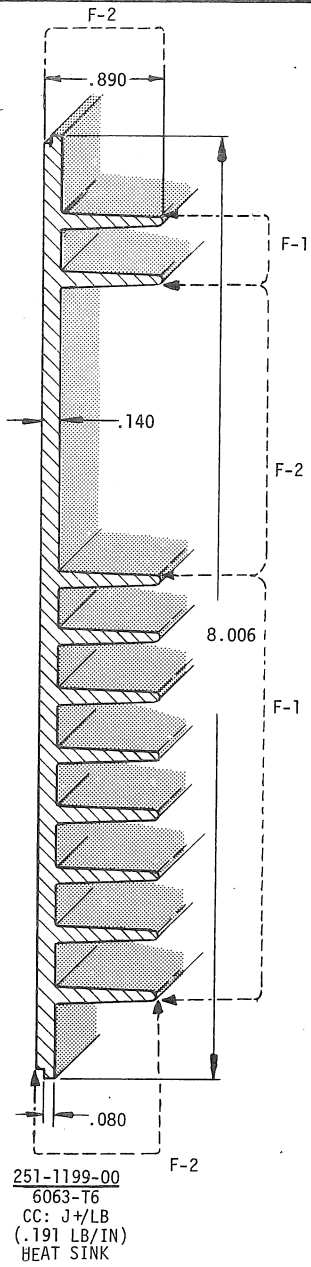

* ALUMINUM EXTRUSION (CONT)

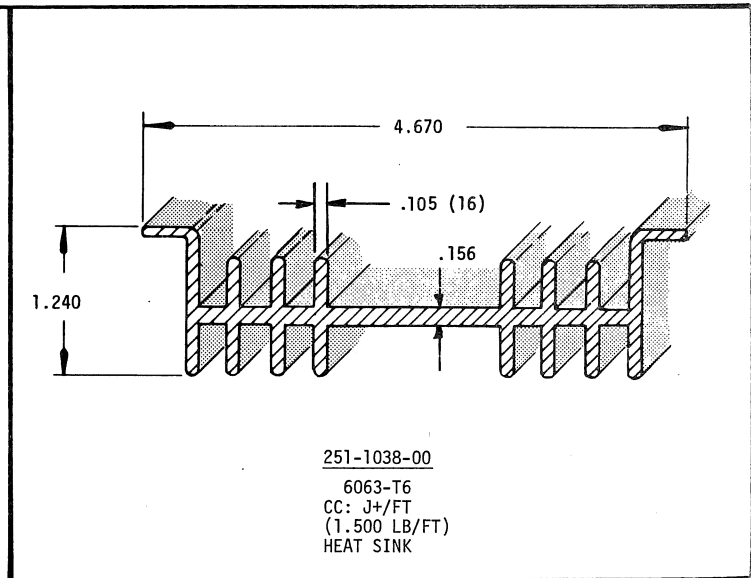
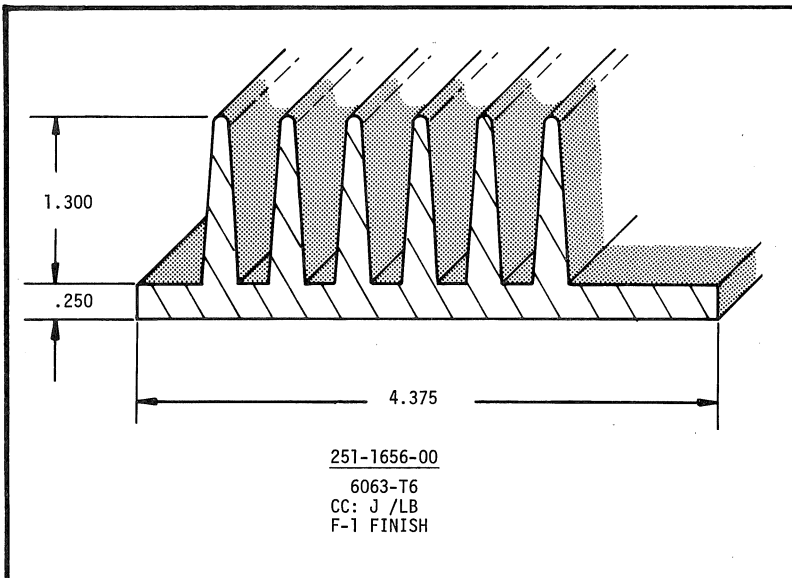

6

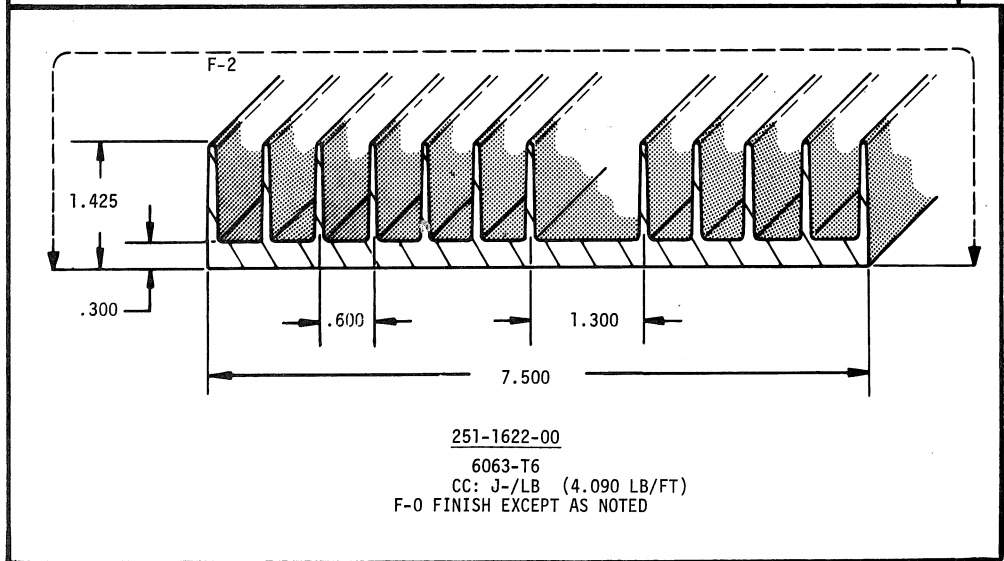
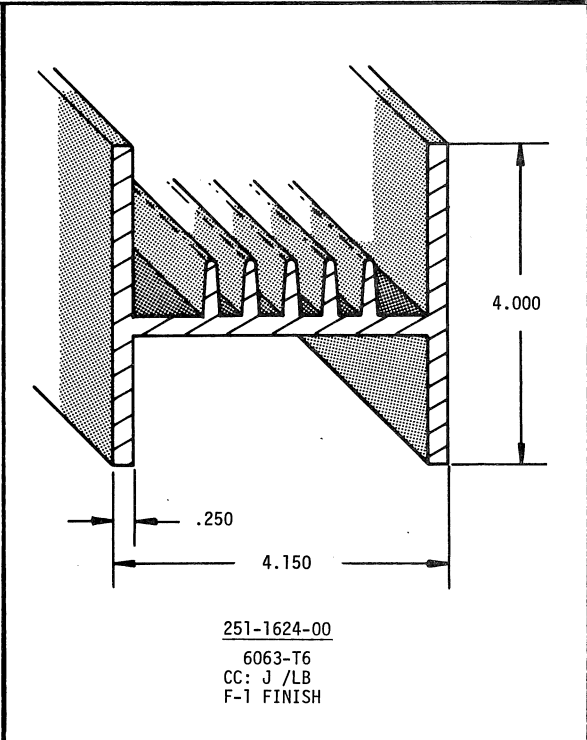
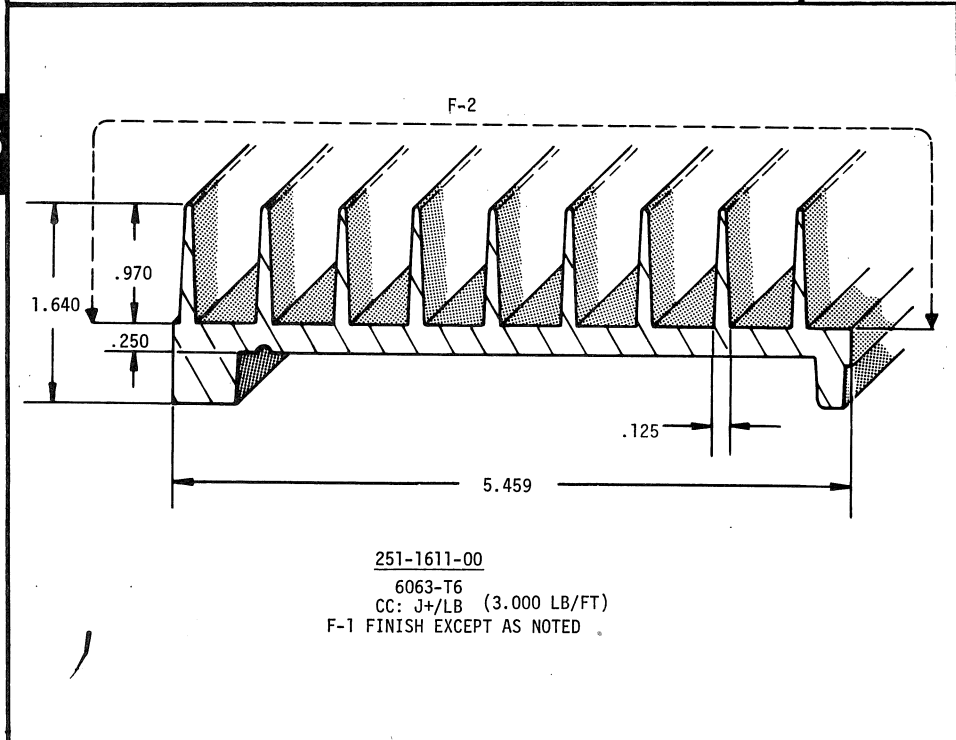

COST CODE (CC COLUMN)

CODE	≈ VALUE with -	≈ VALUE no suffix	≈ VALUE with +
A	.2¢	.5¢	.75¢
B	1.25¢	1.5¢	2¢
C	2.5¢	3¢	3.75¢
D	4.25¢	5¢	6¢
E	7¢	8¢	10¢
F	13¢	15¢	18¢
G	22¢	25¢	35¢
H	40¢	50¢	60¢
I	65¢	75¢	\$1
J	\$1.25	\$1.50	\$2
K	\$2.50	\$3	\$3.75
L	\$4.25	\$5	\$6
M	\$7	\$8	\$10
N	\$13	\$15	\$18
O	\$22	\$25	\$35+

ALUMINUM EXTRUSION (CONT) MODULAR PACKAGING SYSTEM

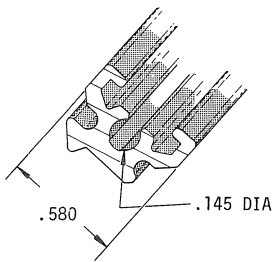

251-1636-00
6063-T6
CC: J /LB (.125 LB/FT)

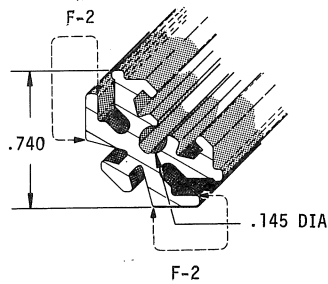

251-1486-00
6063-T6
CC: J+/LB (.213 LB/FT)
F-1 EXCEPT AS NOTED

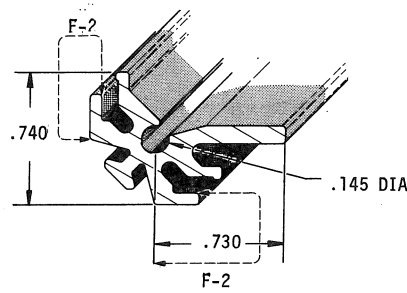

251-1555-00
6063-T6
CC: K-/LB (.275 LB/FT)
F-1 EXCEPT AS NOTED

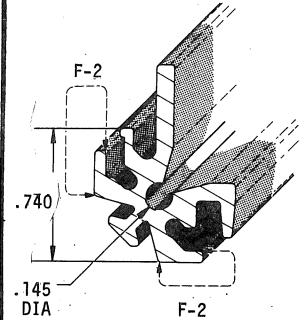

251-1682-00
6063-T6
CC: J+/LB (.332 LB/FT)
F-1 EXCEPT AS NOTED

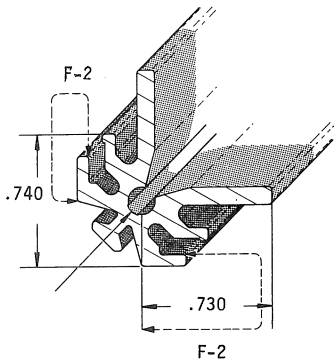

251-1556-00
6063-T6
CC: K-/LB (.342 LB/FT)
F-1 EXCEPT AS NOTED

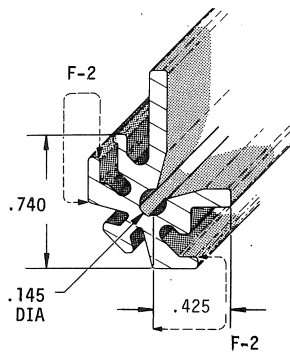

251-1730-00
6063-T6
CC: K-/LB (.258 LB/FT)
F-1 EXCEPT AS NOTED

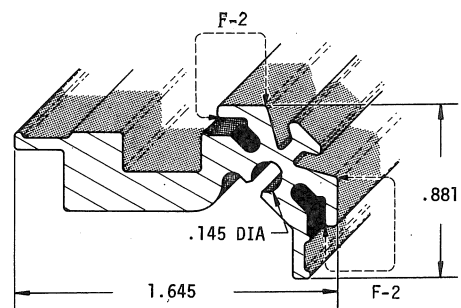

251-1587-00
6063-T6
CC: K /LB (.502 LB/FT)
F-1 EXCEPT AS NOTED

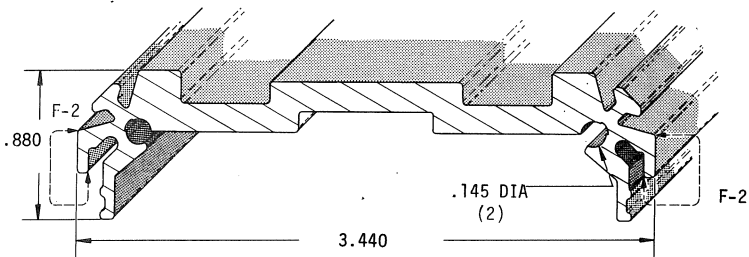

251-1592-00
6063-T6
CC: I+/LB (.995 LB/FT)
F-1 EXCEPT AS NOTED

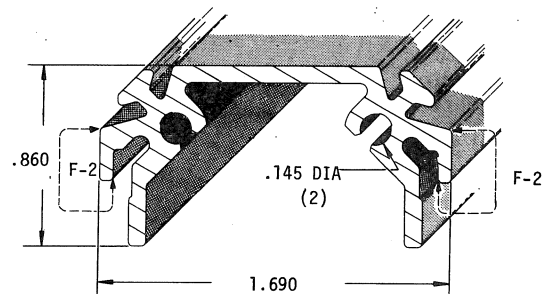

251-1586-00
6063-T6
CC: K /LB (.423 LB/FT)
F-1 EXCEPT AS NOTED

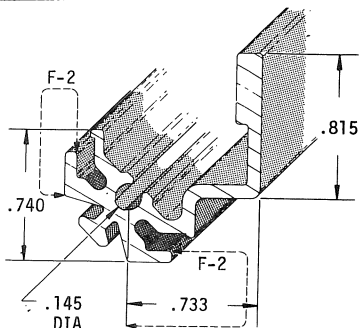

251-1726-00
6063-T6
CC: J+/LB
F-1 EXCEPT AS NOTED

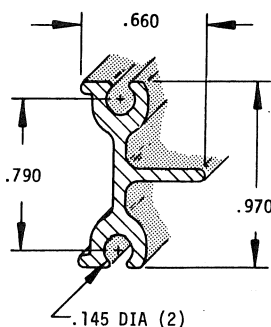

251-1471-00
6063-T6
CC: J /LB (.202 LB/FT)

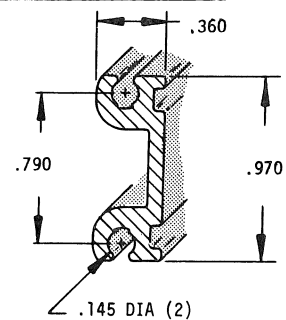

251-1650-00
6063-T6
CC: J-/LB (.196 LB/FT)

ALUMINUM EXTRUSION (CONT) MODULAR PACKAGING SYSTEM

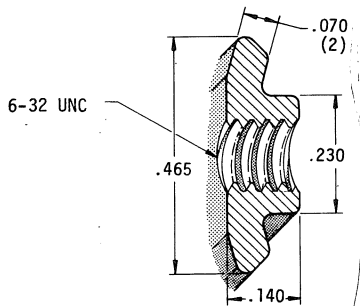
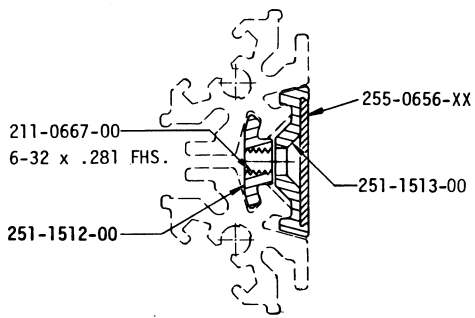

251-1512-00 6063-T6
(.064 lbs/ft)
CC: K-/1b

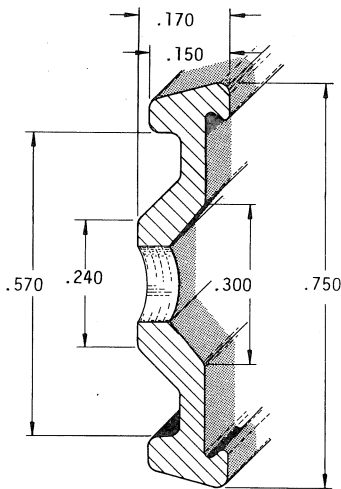

251-1513-00 6063-T6
(.078 lbs/ft) CC: K-/LB

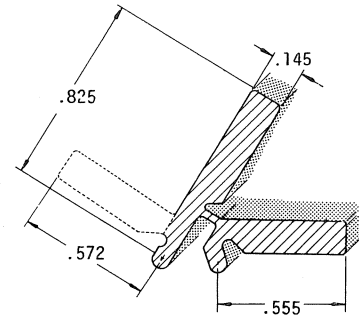

251-1487-00 6063-T6 .075 lbs/ft CC: K-/1b

251-1492-00 (w/dotted portion) 6063-T6
(.200 lb/ft) CC: K-/1b

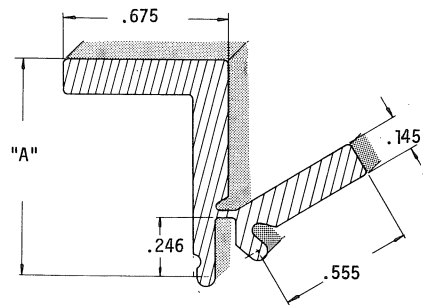

251-1488-00 "A" .895 CC: K /LB (.341 LB/FT)

251-1552-00 "A" .803 CC: K-/LB (.302 LB/FT)
6063-T6

6

COST CODE (CC COLUMN)

CODE	A	B	C	D	E	F	G	H	I	J	K	L	M	N	O
≈ VALUE with +	.75¢	2¢	3.75¢	6¢	10¢	18¢	35¢	60¢	\$1	\$2	\$3.75	\$6	\$10	\$18	\$35+
≈ VALUE no suffix	.5¢	1.5¢	3¢	5¢	8¢	15¢	25¢	50¢	75¢	\$1.50	\$3	\$5	\$8	\$15	\$25
≈ VALUE with -	.2¢	1.25¢	2.5¢	4.25¢	7¢	13¢	22¢	40¢	65¢	\$1.25	\$2.50	\$4.25	\$7	\$13	\$22

NOTE: Costs may vary from order to order due to order quantities, vendor, etc.

CROSS REFERENCE INDEX

ALUMINUM EXTRUSIONS

PART NUMBER	PAGE NO.	STATUS§§	PART NUMBER	PAGE NO.	STATUS§§	PART NUMBER	PAGE NO.	STATUS§§
006-1610-00		DL	251-0267-00	6-6	CR	251-1112-00	6-13	OT
251-0002-00	6-2	CR	251-0268-00	6-6	CR	251-1114-00	6-13	CR
251-0004-00	6-2	CS	251-0269-00	6-6	CR	251-1115-00	6-20	CR
251-0048-00		OB	251-0270-00	6-6	CR	251-1116-00	6-10	CR
251-0049-00	6-2	CR	251-0275-00	6-10	CR	251-1117-00	6-22	CR
251-0061-00	6-30	CR	251-0276-00	6-10	CR	251-1120-00	6-7	CR
251-0067-00	6-3	CS	251-0277-00	6-12	CS	251-1122-00	6-33	CS
251-0069-00	6-2	CS	251-0278-00	6-12	CR	251-1124-00	6-4	CR
251-0083-00	6-22	CS	251-0279-00	6-12	CR	251-1126-00	6-20	CR
251-0088-00	6-18	CS	251-0282-00	6-19	CR	251-1127-00	6-13	CS
251-0090-00	6-6	OB	251-0283-00	6-12	CR	251-1129-00	6-2	CR
251-0092-00		OB	251-0290-00	6-3	CR	251-1131-00	6-12	CR
251-0097-00	6-15	CR	251-0291-00	6-6	CR	251-1132-00	6-5	CR
251-0098-00	6-9	OB	251-0292-00	6-18	CS	251-1135-00	6-19	CR
251-0102-00	6-16	CR	251-0293-00	6-10	CR	251-1136-00		DL
251-0104-00	6-17	OB	251-0298-00	6-3	CS	251-1137-00	6-19	CR
251-0106-00	6-29	CR	251-0299-00	6-3	CR	251-1138-00	6-20	CR
251-0115-00	6-22	CR	251-0300-00	6-20	CR	251-1140-01	6-17	OB
251-0117-00	6-6	CS	251-1003-00	6-2	CR	251-1141-00	6-14	CR
251-0118-00	6-3	CS	251-1008-00	6-2	CR	251-1142-00	6-13	CR
251-0119-00	6-2	CR	251-1009-00	6-6	CR	251-1143-00	6-10	CR
251-0120-00	6-29	CS	251-1010-00	6-3	CR	251-1146-00	6-16	CR
251-0121-00	6-6	CS	251-1015-00	6-30	CR	251-1147-00	6-5	CR
251-0126-00	6-2	CR	251-1015-01	6-30	CR	251-1149-00	6-15	CR
251-0128-00	6-19	CS	251-1020-00	6-2	CR	251-1150-00	6-21	CR
251-0134-00	6-12	CR	251-1021-00		NP	251-1151-00	6-4	CR
251-0137-01	6-15	CR	251-1021-01	6-27	CR	251-1152-00	6-4	CR
251-0140-00	6-3	OB	251-1023-00	6-12	CR	251-1153-00	6-15	CR
251-0144-00	6-2	CR	251-1024-00	6-12	CR	251-1154-00	6-16	CR
251-0150-00	6-3	CS	251-1029-00	6-10	CR	251-1155-00	6-4	CR
251-0156-00	6-21	CR	251-1030-00	6-10	CR	251-1156-00	6-5	CR
251-0160-00	6-21	CR	251-1032-00	6-6	CS	251-1158-00	6-22	CR
251-0161-00	6-21	CS	251-1033-00	6-3	CR	251-1161-00	6-22	OT
251-0169-00	6-6	CS	251-1034-00	6-21	CR	251-1162-00	6-13	CR
251-0171-00	6-6	CR	251-1035-00	6-21	CR	251-1163-00	6-13	CR
251-0176-00	6-12	CR	251-1037-00	6-6	CR	251-1164-00	6-13	CR
251-0177-00	6-35	CS	251-1038-00	6-36	CR	251-1165-00		DL
251-0183-00	6-10	CR	251-1041-00	6-3	CS	251-1169-00		OB
251-0185-00	6-17	CS	251-1042-00	6-6	CR	251-1170-00	6-20	CR
251-0186-00	6-19	CS	251-1043-00	6-6	CR	251-1172-00	6-2	CR
251-0189-00	6-17	CS	251-1044-00	6-12	OB	251-1173-00	6-19	OB
251-0190-00		DL	251-1046-00	6-4	CR	251-1174-00	6-13	CR
251-0191-00	6-2	CR	251-1048-00	6-34	CR	251-1175-00	6-13	CR
251-0192-00	6-3	CS	251-1049-00	6-2	CS	251-1176-00	6-16	CR
251-0193-00	6-9	CS	251-1052-00	6-18	OB	251-1177-00	6-7	CR
251-0194-00	6-6	CS	251-1054-00	6-2	CS	251-1181-00	6-2	CR
251-0197-00	6-3	OB	251-1060-00	6-19	OB	251-1182-00	6-4	CR
251-0198-00	6-20	CS	251-1061-00	6-33	CS	251-1183-00	6-4	CR
251-0201-00	6-35	CS	251-1064-00	6-8	CR	251-1184-00	6-7	CR
251-0204-00	6-16	CR	251-1065-00	6-16	CR	251-1185-00	6-14	CR
251-0205-00	6-2	CR	251-1067-00	6-4	OB	251-1189-00	6-4	CR
251-0206-00	6-10	CS	251-1068-00	6-30	CR	251-1191-00	6-4	OT
251-0216-00	6-14	CR	251-1069-00	6-8	CS	251-1192-00	6-16	CR
251-0217-00	6-12	CR	251-1070-00	6-29	CR	251-1193-00	6-19	CR
251-0218-00	6-15	CR	251-1071-00	6-17	CS	251-1194-00	6-5	CR
251-0219-00	6-15	CR	251-1072-00	6-10	CR	251-1195-00	6-16	CR
251-0224-00	6-10	CR	251-1073-00	6-10	CS	251-1196-00	6-4	CR
251-0226-00	6-2	CR	251-1074-00	6-8	OB	251-1197-00	6-4	CR
251-0228-00	6-16	CR	251-1076-00	6-10	CR	251-1199-00	6-35	CR
251-0234-00	6-6	CS	251-1077-00	6-18	CS	251-1200-00	6-19	CR
251-0239-00	6-12	CS	251-1078-00	6-4	CR	251-1201-00	6-19	CR
251-0240-00	6-6	CS	251-1079-00	6-8	OB	251-1203-00	6-21	CR
251-0242-00	6-2	CR	251-1085-00	6-11	CR	251-1205-00	6-16	OT
251-0245-00	6-2	OT	251-1088-01	6-10	CR	251-1206-00	6-16	CR
251-0251-00	6-2	CR	251-1089-00	6-10	CR	251-1208-00	6-5	CR
251-0252-00	6-16	CR	251-1090-00	6-6	CR	251-1209-00	6-22	CR
251-0256-00		NP	251-1093-00	6-33	OB	251-1210-00	6-13	CR
251-0257-00	6-16	CS	251-1094-00	6-10	CR	251-1220-00	6-34	CR
251-0258-00	6-21	CR	251-1095-00	6-10	CR	251-1221-00	6-7	CR
251-0260-00	6-12	CS	251-1097-00	6-10	CR	251-1222-00	6-8	CR
251-0261-00	6-4	CS	251-1098-00	6-16	CS	251-1223-00	6-19	CR
251-0262-00	6-3	CS	251-1105-00	6-7	CR	251-1224-00	6-21	CR
251-0264-00	6-3	CR	251-1108-00	6-18	CR	251-1225-00	6-17	CR
251-0265-00	6-3	CR	251-1110-00	6-34	OB	251-1226-00	6-7	PP
251-0266-00	6-3	CR	251-1111-00	6-5	CS	251-1229-00	6-17	CR

CROSS REFERENCE INDEX (CONT)

ALUMINUM EXTRUSIONS

PART NUMBER	PAGE NO.	STATUS§§
251-1231-00	6-30	CR
251-1233-00	6-7	CR
251-1234-00		DL
251-1235-00		DL
251-1236-00	6-13	CR
251-1237-00	6-13	CR
251-1241-00		DL
251-1244-00	6-10	CR
251-1249-00	6-8	CS
251-1252-00	6-17	CR
251-1258-00	6-16	OB
251-1259-00	6-29	OB
251-1260-00	6-14	OB
251-1261-00	6-14	CR
251-1262-00	6-4	CR
251-1263-00	6-7	CS
251-1264-00	6-14	CS
251-1265-00	6-17	CR
251-1266-00	6-17	CR
251-1268-00	6-13	CR
251-1269-00	6-29	CS
251-1271-00	6-19	CS
251-1272-00	6-4	CS
251-1278-00	6-19	CR
251-1285-00	6-10	CR
251-1291-00	6-5	CR
251-1292-00	6-2	CR
251-1293-00	6-22	CR
251-1296-00	6-5	CS
251-1297-00	6-10	CR
251-1298-00	6-2	CR
251-1300-00	6-10	CR
251-1302-00	6-5	CR
251-1303-00	6-7	CS
251-1304-00	6-14	CR
251-1312-00	6-2	CR
251-1314-00	6-14	CR
251-1315-00	6-14	CR
251-1320-00	6-33	CR
251-1321-00	6-15	CR
251-1322-00	6-15	CR
251-1323-00	6-10	CR
251-1325-00	6-16	CR
251-1326-00	6-33	MP
251-1326-01	6-35	CR
251-1329-00	6-10	CR
251-1330-00	6-29	CR
251-1331-00	6-19	CR
251-1332-00	6-16	CS
251-1333-00	6-15	CR
251-1336-00	6-5	CR
251-1345-00	6-15	CR
251-1346-00	6-5	CR
251-1347-00	6-15	OT
251-1349-00	6-16	CR
251-1353-00	6-14	CS
251-1354-00	6-6	CR
251-1360-00	6-10	CR
251-1361-00	6-10	CR
251-1365-00	6-35	CR
251-1366-00	6-32	CS
251-1367-00	6-5	CR
251-1369-00	6-14	CR
251-1370-00	6-21	CR
251-1371-00	6-7	CR
251-1372-00	6-21	CS
251-1375-00	6-22	CR
251-1376-00	6-14	CR
251-1377-00	6-33	CR
251-1380-00	6-7	CR
251-1384-00		NP
251-1385-00		NP
251-1386-00	6-16	CR
251-1390-00	6-35	CR
251-1391-00		DL

PART NUMBER	PAGE NO.	STATUS§§
251-1393-00	6-16	CR
251-1394-00	6-8	CR
251-1396-00	6-5	CR
251-1397-00	6-21	CR
251-1423-00	6-20	CR
251-1424-00	6-22	CR
251-1425-00	6-5	CR
251-1428-00	6-14	CR
251-1431-00		LS
251-1433-00	6-34	CS
251-1434-00	6-7	CR
251-1435-00	6-11	CR
251-1444-00	6-14	CR
251-1447-00	6-8	CS
251-1448-00		NP
251-1449-00	6-22	CS
251-1451-00	6-10	CR
251-1452-00	6-28	CR
251-1453-00	6-28	CR
251-1454-00	6-32	CR
251-1455-00	6-32	CR
251-1456-02	6-29	CR
251-1457-00	6-32	CR
251-1458-00	6-14	CR
251-1460-00		DL
251-1461-00	6-9	CR
251-1462-00	6-9	CR
251-1463-00		DL
251-1464-00	6-29	CS
251-1465-00	6-21	CS
251-1469-00	6-8	CR
251-1470-00	6-18	CR
251-1471-00	6-37	CR
251-1472-00	6-18	CR
251-1475-00	6-25	CR
251-1476-00	6-25	CR
251-1477-00	6-11	CR
251-1478-00	6-23	CR
251-1479-00	6-35	CR
251-1480-00	6-25	CR
251-1482-00	6-10	CR
251-1485-00	6-10	CR
251-1486-00	6-37	CR
251-1487-00	6-38	CR
251-1488-00	6-38	CR
251-1489-00	6-11	CR
251-1490-00	6-22	CR
251-1491-00	6-22	CR
251-1492-00	6-38	CR
251-1495-00	6-2	CR
251-1496-00	6-8	CR
251-1497-00	6-9	CR
251-1498-00	6-9	CR
251-1499-00	6-8	CR
251-1500-00	6-22	CR
251-1501-00		NP
251-1501-01	6-26	CR
251-1502-00	6-11	CR
251-1503-00	6-9	CR
251-1504-00	6-11	CR
251-1505-00	6-11	CR
251-1506-00	6-11	CR
251-1507-00	6-31	CR
251-1510-00	6-9	CR
251-1512-00	6-38	CR
251-1513-00	6-38	CR
251-1514-00	6-23	CR
251-1515-00	6-23	CR
251-1517-00	6-23	CR
251-1518-00	6-23	CR
251-1519-00	6-23	CR
251-1520-00	6-23	CR
251-1521-00	6-23	CR
251-1522-00	6-18	CR
251-1523-00	6-18	CR

PART NUMBER	PAGE NO.	STATUS§§
251-1529-00	6-23	CR
251-1530-00	6-22	CR
251-1531-00	6-22	CR
251-1532-00	6-26	CR
251-1534-00	6-18	CR
251-1538-00	6-30	CR
251-1540-00	6-9	CR
251-1541-00	6-9	CR
251-1545-00	6-31	CR
251-1549-00	6-31	CR
251-1550-00	6-31	CR
251-1552-00	6-38	CR
251-1553-00	6-24	CR
251-1554-00	6-24	CR
251-1555-00	6-37	CR
251-1556-00	6-37	CR
251-1560-00	6-24	CR
251-1563-00	6-8	CR
251-1565-00	6-24	CR
251-1566-00	6-9	CR
251-1567-00	6-25	CR
251-1568-00	6-15	CR
251-1569-00	6-9	CR
251-1570-00		DL
251-1572-00	6-9	CR
251-1573-01	6-24	CR
251-1574-00	6-27	CR
251-1575-00	6-26	CR
251-1576-00	6-28	CR
251-1577-00	6-27	CR
251-1578-00	6-9	CR
251-1580-00	6-31	CR
251-1581-00	6-28	CR
251-1582-00	6-9	CR
251-1584-00	6-28	CR
251-1585-00	6-26	CR
251-1586-00	6-37	CR
251-1587-00	6-37	CR
251-1588-00	6-31	CR
251-1589-00	6-24	CR
251-1591-00	6-31	PP
251-1592-00	6-37	CR
251-1593-00	6-24	CR
251-1594-00	6-10	CR
251-1597-00	6-7	CR
251-1598-00	6-12	CR
251-1599-00	6-24	CR
251-1600-00	6-26	CR
251-1605-00	6-25	CR
251-1606-00	6-25	CR
251-1608-00	6-10	CR
251-1609-00	6-2	CR
251-1611-00	6-36	CR
251-1615-00	6-25	CR
251-1616-00	6-17	CR
251-1622-00	6-36	CR
251-1624-00	6-36	CR
251-1629-00	6-26	CR
251-1630-00	6-26	CR
251-1631-00	6-27	CR
251-1633-00	6-2	CR
251-1635-00	6-25	CR
251-1636-00	6-37	EN
251-1637-00	6-2	CR
251-1640-00	6-7	CR
251-1649-00	6-10	CR
251-1650-00	6-37	CR
251-1656-00	6-36	CR
251-1671-00	6-28	CR
251-1672-00	6-27	CR
251-1673-00	6-28	CR
251-1675-00	6-2	CR
251-1678-00	6-7	CR
251-1680-00	6-7	CR
251-1681-00	6-2	CR

CROSS REFERENCE INDEX (CONT)

ALUMINUM EXTRUSIONS

PART NUMBER	PAGE NO.	STATUS ^{§§}
251-1682-00	6-37	EN
251-1685-00	6-30	CR
251-1691-00	6-25	CR
251-1691-01	6-25	CR
251-1697-00	6-19	CR
251-1698-00	6-2	CR
251-1699-00	6-27	CR
251-1700-00	6-27	CR
251-1701-00	6-18	CR
251-1703-00	6-2	CR
251-1704-00	6-19	CR
251-1706-00	6-25	MP
251-1707-00	6-25	MP
251-1709-00	6-7	CR
251-1726-00	6-37	EN
251-1730-00	6-37	CR

§§ STATUS CODES

CR	Current Production
EN	Engineering
PP	Pre-Production
CS	Customer Service
NP	Non-Production
DL	Deleted
OB	Obsolete Instrument
CM	Custom Mod Instrument
DS	Digital Systems
OT	Obsolescent Instrument
MP	Modified Part
LR	Last Supply Current
LS	Last Supply Customer Service
VN	Vendor
TC	Tequipment Current Production
IN	International
SC	Sony/Tek Current Production

THE STATUS IN THIS CATALOG WAS CORRECT AT THE TIME IT WAS PUBLISHED, BUT IT IS SUBJECT TO CHANGE.

§ TO USE A PART WITH THIS STATUS ON A NEW INSTRUMENT REQUIRES THAT A NEW PURCHASED PART INITIATION FORM (PPIF) BE INITIATED.

(A GLOSSARY OF TERMS FOR THESE STATUS CODES CAN BE FOUND ON PAGE 0-10).

NOTES

6

COST CODE (CC COLUMN)

CODE	A	B	C	D	E	F	G	H	I	J	K	L	M	N	O
≈ VALUE with +	.75¢	2¢	3.75¢	6¢	10¢	18¢	35¢	60¢	\$1	\$2	\$3.75	\$6	\$10	\$18	\$35+
≈ VALUE no suffix	.5¢	1.5¢	3¢	5¢	8¢	15¢	25¢	50¢	75¢	\$1.50	\$3	\$5	\$8	\$15	\$25
≈ VALUE with -	.2¢	1.25¢	2.5¢	4.25¢	7¢	13¢	22¢	40¢	65¢	\$1.25	\$2.50	\$4.25	\$7	\$13	\$22

NOTE: Costs may vary from order to order due to order quantities, vendor, etc.

ALUMINUM EXTRUSION (CONT)

MECHANICAL PROPERTIES (PER ASTM B221)

ALLOY & TEMPER	SPECIFIED SECTION OF WALL THICKNESS, IN.	TENSILE STRENGTH KSI*	YIELD STRENGTH (.2% OFFSET) MIN KSI*	ELONGATION IN 2 IN. OR 4 x DIA MIN %
2024 T4 T3510 T3511	up thru .249	57	42	12
	.25-.749	60	44	12
	.75-1.499	65	46	10
	1.5 and over	70	52	10
		68	48	8
6061 T6, T62 T6510 T6511	up thru .249	38	35	8
	.25 and over	38	35	10
6063 T4, T42	up thru .5	19	10	14
	.501-1.	18	9	14
T5	up thru .5	22	16	8
	.501-1.	21	15	8
T52	up thru 1.	22	16	8
T6	up thru .124	33	25	8
	.125-1.	30	25	10

*KSI = 1000 psi

** THE FULL TEXT OF THIS ASTM IS AVAILABLE FOR REVIEW AT 58-120 or FOR MORE INFORMATION, CALL NORMA - EXT. 7977.

6

INDEX TO TABLES OF PERMISSIBLE VARIATION OF ANSI H35.2 ASTM B221

TABLE NO.

- 10.1 Cross-Sectional Dimensions: Wire, Rod, Bar & Shapes Except for Shapes in T3510, T4510, T6510, T73510, T76510 and T8510 Tempers
- 10.2 Length: Wire, Rod, Bar and Shapes
- 10.3 Straightness: Rod, Bar and Shapes
- 10.4 Twist: Bar and Shapes
- 10.5 Flatness: Flat Surfaces
- 10.6 Flatness: Flat Surfaces, Hollow Shapes Except for O, T3510, T4510, T6510, T73510, T76510 and T8510 Tempers
- 10.7 Surface Roughness: Wire, Rod, Bar and Shapes
- 10.8 Contour (Curved Surfaces): Shapes Except for O, T3510, T4510, T6510, T73510, T76510 and T8510 Tempers
- 10.9 Squareness of Cut Ends: Wire, Rod, Bar and Shapes
- 10.10 Corner and Fillet Radii: Bar and Shapes
- 10.11 Angularity: Bar and Shapes Except for O, T3510, T4510, T6510, T73510, T76510, and T8510 Tempers
- 12.1 Diameter Round Tube Except for T3510, T4510, T6510, T73510, T76510 and T8510 Tempers
- 12.2 Width and Depth: Square, Rectangular, Hexagonal, Octagonal Tube Except for T3510, T4510, T6510, T73510, T76510 and T8510 Tempers
- 12.3 Wall Thickness: Round Tube
- 12.4 Wall Thickness: Other Than Round Tube
- 12.5 Length Extruded Tube
- 12.6 Twist: Other Than Round Tube
- 12.7 Straightness: Tube in Straight Lengths
- 12.8 Flatness: Flat Surfaces
- 12.9 Squareness of Cut Ends: Extruded Tube
- 12.10 Corner and Fillet Radii: Tube Other Than Round
- 12.11 Angularity: Tube Other Than Round
- 12.12 Surface Roughness: Extruded Tube
- 12.13 Dents: Extruded Tube

12.1 THRU 12.13 TABLES ARE ON PAGES 6-18 THRU 6-21

ALUMINUM EXTRUSION (CONT)

TABLE NO. 10.1

CROSS-SECTIONAL DIMENSIONS

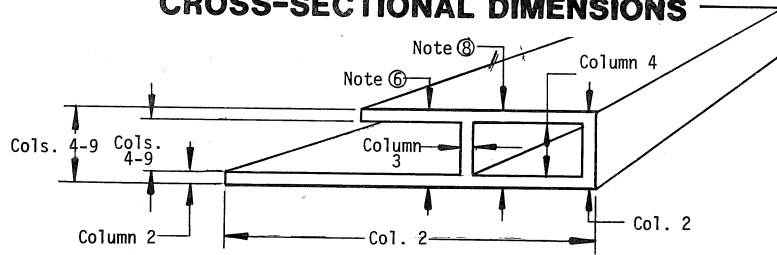

TOLERANCE ②③ - INCH PLUS AND MINUS																		
SPECIFIED DIMENSION	METAL DIMENSIONS								SPACE DIMENSIONS									
	ALLOWABLE DEVIATION FROM SPECIFIED DIMENSION WHERE 75 PER CENT OR MORE OF THE DIMENSION IS METAL ⑤⑩								ALLOWABLE DEVIATION FROM SPECIFIED DIMENSION WHERE MORE THAN 25 PER CENT OF THE DIMENSION IS SPACE ⑥⑧									
	ALL EXCEPT THOSE COVERED BY COLUMN 3 (SOLID STOCK)		WALL THICKNESS ④ COMPLETELY ⑤ ENCLOSING SPACE 0.11 SQ. IN AND OVER (ECCENTRICITY)		AT DIM. POINTS 0.250 - 0.624 IN. FROM BASE OF LEG		AT DIM. POINTS 0.625 - 1.249 IN. FROM BASE OF LEG		AT DIM. POINTS 1.250 - 2.499 IN. FROM BASE OF LEG		AT DIM. POINTS 2.500 - 3.999 IN. FROM BASE OF LEG		AT DIM. POINTS 4.000 - 5.999 IN. FROM BASE OF LEG		AT DIM. POINTS 6.000 - 8.000 IN. FROM BASE OF LEG			
COLUMN 1	COLUMN 2		COLUMN 3		COLUMN 4		COLUMN 5		COLUMN 6		COLUMN 7		COLUMN 8		COLUMN 9			
	ALLOYS 5083, 5086, 5456	OTHER ALLOYS	ALLOYS 5083, 5086, 5456	OTHER ALLOYS	ALLOYS 5083, 5086, 5456	OTHER ALLOYS	ALLOYS 5083, 5086, 5456	OTHER ALLOYS	ALLOYS 5083, 5086, 5456	OTHER ALLOYS	ALLOYS 5083, 5086, 5456	OTHER ALLOYS	ALLOYS 5083, 5086, 5456	OTHER ALLOYS	ALLOYS 5083, 5086, 5456	OTHER ALLOYS		
CIRCUMSCRIBING CIRCLE SIZES LESS THAN 10 INCHES IN DIAMETER																		
Up thru 0.124	.009	.006	±15% of specified dimension; ±.090 max ±.015 min	±10% of specified dimension; ±.060 max ±.010 min	.013	.010	.015	.012	--	--	--	--	--	--	--	--		
0.125 - 0.249	.011	.007			.016	.012	.018	.014	.020	.016	--	--	--	--	--	--	--	
0.250 - 0.499	.012	.008			.018	.014	.020	.016	.022	.018	.024	.020	--	--	--	--	--	
0.500 - 0.749	.014	.009			.021	.016	.023	.018	.025	.020	.027	.022	--	--	--	--	--	
0.750 - 0.999	.015	.010			.023	.018	.025	.020	.027	.022	.030	.025	.035	.030	--	--	--	
1.000 - 1.499	.018	.012	±15% of specified dimension; ±.090 max ±.015 min	±10% of specified dimension; ±.060 max ±.010 min	.027	.021	.029	.023	.032	.026	.036	.030	.041	.035	--	--		
1.500 - 1.999	.021	.014			.031	.024	.033	.026	.038	.031	.043	.036	.049	.042	.057	.050		
2.000 - 3.999	.036	.024			.046	.034	.050	.038	.060	.048	.069	.057	.080	.068	.092	.080		
4.000 - 5.999	.051	.034			.061	.044	.067	.050	.081	.064	.095	.078	.111	.094	.127	.110		
6.000 - 7.999	.066	.044			.07	.054	.084	.062	.104	.082	.121	.099	.142	.120	.162	.140		
8.000 - 9.999	.081	.054			.091	.064	.101	.074	.127	.100	.147	.120	.182	.145	.197	.170		
10.000 - 11.999	.096	.064			±15% of specified dimension; ±.090 max ±.015 min	±10% of specified dimension; ±.060 max ±.010 min	.106	.074	.116	.084	.142	.110	.162	.130	.182	.150	.242	.210
12.000 - 13.999	.111	.074					.121	.084	.131	.094	.157	.120	.177	.140	.197	.15	.257	.220
14.000 - 15.999	.126	.084	.136	.094			.146	.104	.172	.130	.192	.150	.212	.170	.272	.230		
16.000 - 17.999	.141	.094	.151	.104			.161	.114	.187	.140	.207	.160	.227	.180	.287	.240		
18.000 - 19.999	.156	.104	.166	.114			.176	.124	.202	.150	.222	.170	.242	.190	.302	.250		
20.000 - 21.999	.171	.114	±15% of specified dimension; ±.090 max ±.015 min	±10% of specified dimension; ±.060 max ±.010 min			.181	.124	.191	.134	.217	.160	.237	.180	.257	.200	.317	.260
22.000 - 24.000	.186	.124					.196	.134	.206	.144	.232	.170	.252	.190	.272	.210	.332	.270
	.201	.134					.211	.144	.221	.154	.247	.180	.267	.200	.287	.220	.347	.280

- ① These Standard Tolerances are applicable to the average shape; wider tolerances may be required for some shapes and closer tolerances may be possible for others.
- ② The tolerances applicable to a dimension composed of two or more component dimensions is the sum of the tolerances of the component dimensions if all of the component dimensions are indicated.
- ③ When a dimension tolerance is specified other than as an equal bilateral tolerance, the value of the Standard Tolerance is that which would apply to the mean of the maximum and minimum dimensions permissible under the tolerance.
- ④ Where dimensions specified are outside and inside, rather than wall thickness itself, the allowable deviation (eccentricity) given in Column 3 applies to mean wall thickness. (Mean wall thickness is the average of two wall thickness measurements taken at opposite sides of the void).
- ⑤ In the case of Class 1 Hollow Shapes the standard wall thickness tolerance for extruded round tube is applicable. (A Class 1 Hollow Shape is one whose void is round and one inch or more in diameter and whose weight is equally distributed on opposite side of two or more equally spaced axes.)
- ⑥ At points less than 0.250 inch from base of leg the tolerances in Column 2 are applicable.
- ⑦ Tolerances for extruded shapes in T3510, T4510, T6510, T73510, T76510 and T8510 tempers shall be agreed upon between purchaser and vendor at the time the contract or order is entered.

- continued on next page -

ALUMINUM EXTRUSION (CONT)

TABLE NO. 10.1 (CONT)

- ⑧ The following tolerances apply where the space is completely enclosed (hollow shapes):
For the width (A) the tolerance is the value shown in Column 4 for the depth (D).

For the depth (D) the tolerance is the value shown in Column 4 for the width (A).

In no case is the tolerance for either width or depth less than at the corners (Column 2, metal dimensions).

Example - Alloy 6061 hollow shape having 1 x 3 inch rectangular outside dimensions: width tolerance is ± 0.021 inch and depth tolerance ± 0.034 inch. (Tolerances at corners, Column 2, metal dimensions, are ± 0.024 inch for the width and ± 0.012 inch for the depth.) Note that the Column 4 tolerance of 0.021 inch must be adjusted to 0.024 inch so that it is not less than the Column 2 tolerance.

- ⑨ These tolerances do not apply to space dimensions such as dimensions "X" and "Z" of the example (right) even when "Y" is 75 percent or more of "X". For the tolerance applicable to dimensions "X" and "Z", use Column 4, 5, 6, 7, 8 or 9, dependent on distance "A".

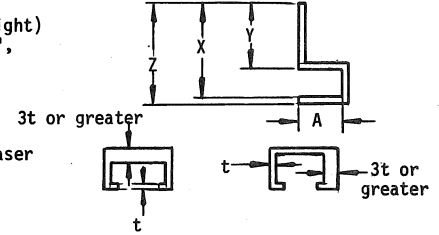
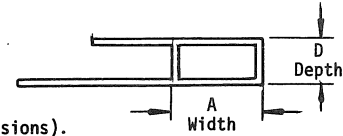

- ⑩ The wall thickness tolerance for hollow or semihollow shapes shall be as agreed upon between purchaser and vendor at the time the contract or order is entered when the nominal thickness of one wall is three times or greater than that of the opposite wall. (Examples at right)

CLOSED-SPACE DIMENSIONS EXAMPLES

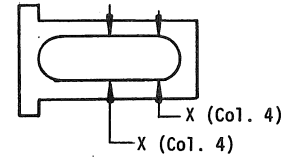
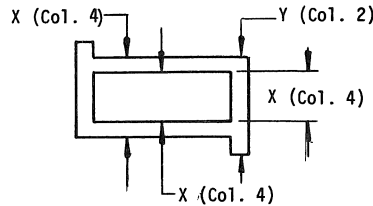
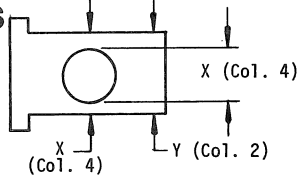

All dimensions designated "Y" are classed as "metal dimensions" and tolerances are determined from column 2.
Dimensions designated "X" are classed as "space dimensions through an enclosed void" and the tolerances applicable are determined from Column 4 unless 75 percent or more of the dimension is metal, in which case Column 2 applies.

OPEN-SPACE DIMENSIONS

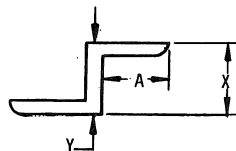
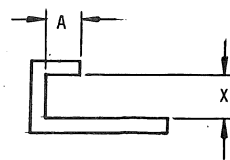
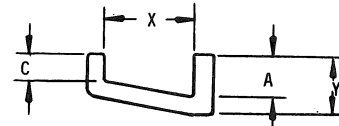
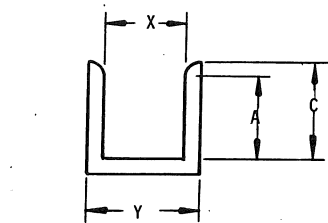
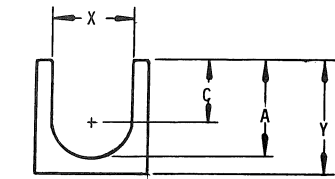

Tolerances applicable to dimensions "X" are determined as follows:

1. Locate dimension "X" in Column 1.
2. Determine which of Columns 4-9 is applicable, dependent on distance "A".
3. Locate proper tolerance in Column 4, 5, 6, 7, 8 or 9 in the same line as dimension "X".

Dimensions "Y" are "metal dimensions"; tolerances are determined from Column 2. Distances "C" are shown merely to indicate incorrect values for determining which of Columns 4-9 apply.

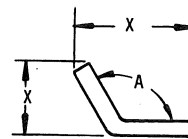
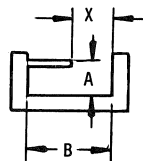
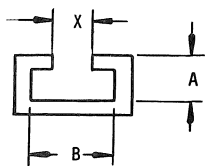

Tolerances applicable to dimensions "X" are determined as follows:

1. Locate distance "B" in Column 1.
2. Determine which of Columns 4-9 is applicable, dependent on distance "A".
3. Locate proper tolerance in Column 4, 5, 6, 7, 8 or 9 in same line as value chosen in Column 1.

Tolerances applicable to dimensions "X" are not determined from Table 10.1; tolerances are determined by standard tolerances applicable to angles "A".

ALUMINUM EXTRUSION (CONT)

PERMISSIBLE VARIATION OF ANSI H35.2 ASTM B221

10. extruded wire, rod, bar and shapes

10.2 ● LENGTH^① WIRE, ROD, BAR AND SHAPES

SPECIFIED DIAMETER (WIRE AND ROD); SPECIFIED WIDTH (BAR); CIRCUMSCRIBING CIRCLE DIAMETER ^④ SHAPES; in.	TOLERANCE—in. Plus			
	ALLOWABLE DEVIATION FROM SPECIFIED LENGTH			
	SPECIFIED LENGTH—ft			
	Up thru 12	Over 12 thru 30	Over 30 thru 50	Over 50
Up thru 2.999 3.000-7.999 8.000 and over	1/8 3/16 1/4	1/4 5/16 3/8	3/8 7/16 1/2	1 1 1

10.3 ● STRAIGHTNESS^① ROD, BAR AND SHAPES

PRODUCT	TEMPER	SPECIFIED DIAMETER (ROD); SPECIFIED WIDTH (BAR); CIRCUMSCRIBING CIRCLE DIAMETER ^④ (SHAPES) in.	SPECIFIED THICKNESS (RECTANGLES); MINIMUM THICKNESS (SHAPES) in.	TOLERANCE ^③ —in.	
				ALLOWABLE DEVIATION (D) FROM STRAIGHT	
				IN ANY FOOT OR LESS OF LENGTH	IN TOTAL LENGTH OF PIECE
Rod and Square, Hexagonal and Octagonal Bar	All except 0, TX510, TX511 ^②	All0125	.0125 × length, ft
	TX510 ^②	0.500 and over050	.050 × length, ft
	TX511 ^②	0.500 and over0125	.0125 × length, ft
Rectangular Bar	All except 0, TX510, TX511 ^②	Up thru 1.499	Up thru 0.094 0.095 and over	.050 .0125	.050 × length, ft .0125 × length, ft
		1.500 and over	All	.0125	.0125 × length, ft
	TX510 ^②	Over 0.500	0.500 and over	.050	.050 × length, ft
	TX511 ^②	Over 0.500	0.500 and over	.0125	.0125 × length, ft
Shapes	All except 0, TX510, TX511 ^②	Up thru 1.499	Up thru 0.094 0.095 and over	.050 .0125	.050 × length, ft .0125 × length, ft
		1.500 and over	All	.0125	.0125 × length, ft
	TX510 ^②	0.500 and over	0.095 and over	⑤	⑤
	TX511 ^②	0.500 and over	0.095 and over	.0125	.0125 × length, ft

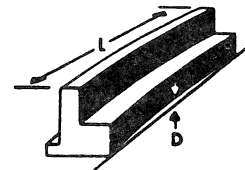

For all numbered footnotes, see page 5-36.

ALUMINUM EXTRUSION (CONT)

PERMISSIBLE VARIATION OF ANSI H35.2 ASTM B221

10.4 ● TWIST^⑥ BAR AND SHAPES

PRODUCT	TEMPER	SPECIFIED WIDTH (BAR); CIRCUMSCRIBING CIRCLE DIAMETER ^④ (SHAPES) in.	SPECIFIED THICKNESS (RECTANGLES); MINIMUM THICKNESS (SHAPES) in.	TOLERANCE ^⑤ —Degrees	
				ALLOWABLE DEVIATION FROM STRAIGHT	
				IN ANY FOOT OR LESS OF LENGTH	IN TOTAL LENGTH OF PIECE
Bar	All except 0, TX510, TX511 ^②	Up thru 1.499 1.500-2.999 3.000 and over	All All All	1 1/2 1/4	1 × length, ft: 7° max 1/2 × length, ft: 5° max 1/4 × length, ft: 3° max
	TX510 ^②	0.500-2.999 3.000 and over	0.500 and over 0.500 and over	1 1/2 1	1 1/2 × length, ft: 7° max 1/2 × length, ft: 5° max
	TX511 ^②	0.500-1.499 1.500-2.999 3.000 and over	0.500 and over 0.500 and over 0.500 and over	1 1/2 1/4	1 × length, ft: 7° max 1/2 × length, ft: 5° max 1/4 × length, ft: 3° max
Shapes	All except 0, TX510, TX511 ^②	Up thru 1.499 1.500-2.999 3.000 and over	All All All	1 1/2 1/4	1 × length, ft: 7° max 1/2 × length, ft: 5° max 1/4 × length, ft: 3° max
	TX510 ^②	0.500 and over	0.095 and over	⑤	⑤
	TX511 ^②	0.500-1.499 1.500-2.999 3.000 and over	0.095 and over 0.095 and over 0.095 and over	1 1/2 1/4	1 × length, ft: 7° max 1/2 × length, ft: 5° max 1/4 × length, ft: 3° max

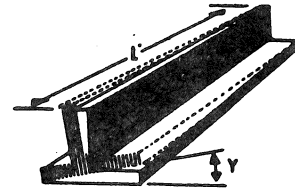

Footnotes for Pages 20-21

① These Standard Tolerances are applicable to the average shape; wider tolerances may be required for some shapes and closer tolerances may be possible for others.

② TX510 and TX511 are general designations for the following stress-relieved tempers: T3510, T4510, T6510, T8510, T73510, T76510 and T3511, T4511, T6511, T8511, T73511, T76511, respectively.

③ When weight of piece on flat surface minimizes deviation.

④ The circumscribing circle diameter is the diameter of the smallest circle that will completely enclose the cross-section of the extruded product.

⑤ Tolerances for 0, T3510, T4510, T6510, T73510, T76510 and T8510 tempers shall be as agreed upon between purchaser and vendor at the time the contract or order is entered.

⑥ Twist is normally measured by placing the extruded section on a flat surface and measuring the maximum distance at any point along its length between the bottom surface of the section and the flat surface. From this measurement, the deviation from true straightness of the section is subtracted. The remainder is the twist. To convert the standard twist tolerance (degrees) to an equivalent linear value, the tangent of the standard tolerance is multiplied by the width of the surface of the section that is on the flat surface. The following values are used to convert angular tolerance to linear deviation.

Tolerance, Degrees	Max. Allowable Linear Deviation in. Per in. of Width
1/4	0.004
1/2	0.009
1	0.017
1 1/2	0.026
3	0.052
5	0.087
7	0.123

10.5 ● FLATNESS (Flat Surfaces)^①

BAR, SOLID SHAPES AND SEMIHOLLOW SHAPES EXCEPT FOR SHAPES IN 0, T3510, T4510, T6510, T73510, T76510 and T8510 TEMPERS^⑤

TOLERANCE—in.	
SURFACE WIDTH in.	<p style="text-align: center;">Maximum Allowable Deviation D</p>
Up thru 1 Over 1 in any 1 in. of width	.004 .004xW (in.) .004

ALUMINUM EXTRUSION (CONT)

PERMISSIBLE VARIATION OF ANSI H35.2 ASTM B221

10. extruded wire, rod, bar and shapes

10.6 ● FLATNESS (Flat Surfaces)^① HOLLOW SHAPES EXCEPT FOR 0, T3510, T4510, T6510, T73510, T76510 AND T8510 TEMPERS^④

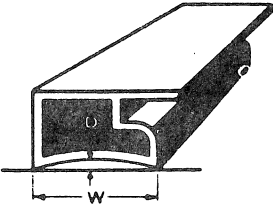
MINIMUM THICKNESS OF METAL FORMING THE SURFACE in.	TOLERANCE—in.	
		
	Maximum Allowable Deviation D	
	WIDTHS UP THRU 1 IN. OR ANY 1 IN. INCREMENT OF WIDER SURFACES	WIDTHS OVER 1 IN.
Up thru 0.187 0.188 and over	0.006 0.004	0.006xW (in.) 0.006xW (in.)

10.7 ● SURFACE ROUGHNESS^① WIRE, ROD, BAR AND SHAPES

SPECIFIED SECTION THICKNESS in.	ALLOWABLE DEPTH OF DEFECTS ^② in. Maximum
Up thru 0.063	.0015
0.064-0.125	.002
0.126-0.188	.0025
0.189-0.250	.003
0.251-0.500	.004
0.501 and over	.008

10.8 ● CONTOUR (Curved Surfaces)^① SHAPES EXCEPT FOR 0, T3510, T4510, T6510, T73510, T76510 AND T8510 TEMPERS^④

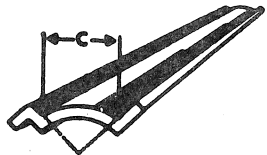

Allowable deviation from specified contour: 0.005 inch per inch of chord length; 0.005 inch minimum.^③

10.9 ● SQUARENESS OF CUT ENDS^① WIRE, ROD, BAR AND SHAPES

Allowable deviation from square: 1 degree.

^①These Standard Tolerances are applicable to the average shape; wider tolerances may be required for some shapes and closer tolerances may be possible for others.

^②Defects include die lines and handling marks.

^③As measured with a contour gauge whose surface is limited to a

10.10 ● CORNER AND FILLET RADII^① BAR AND SHAPES

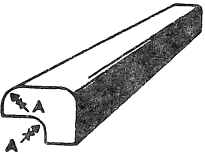
SPECIFIED RADIUS in.	TOLERANCE—in. or Percent
	
	ALLOWABLE DEVIATION FROM SPECIFIED RADIUS
	Difference between radius A and specified radius
Sharp corners Up thru 0.187 0.188 and over	+1/64 ±1/64 ±10%

10.11 ● ANGULARITY^{①⑤}

BAR AND SHAPES EXCEPT SHAPES IN 0, T3510, T4510,
T6510, T73510, T76510 and T8510 TEMPERS^④

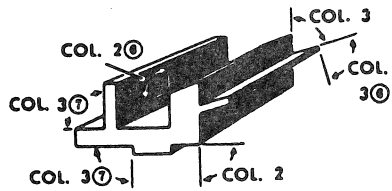
MINIMUM SPECIFIED LEG THICKNESS in.	TOLERANCE Degrees Plus and Minus		
			
	ALLOWABLE DEVIATION FROM SPECIFIED ANGLE		
	RATIO: ^{⑥⑦} LEG OR SURFACE LENGTH TO LEG OR METAL THICKNESS		
	1 and less	Over 1	
Col. 1	Col. 2	Col. 3	
Up thru 0.187	1	2	
0.188-0.749	1	1 1/2	
0.750 and over	1	1	

maximum subtended angle of 90 degrees. Extruded curved surfaces comprising more than a 90-degree subtended angle are checked by sliding the gauge across the surface, thus checking two or more 90-degree portions of the surface. Extruded shape surfaces comprised of arcs formed by two or more radii require the use of a separate contour gauge for each portion of the surface formed by an individual radius.

^④Tolerances for 0, T3510, T4510, T6510, T73510, T76510 and T8510 tempers shall be as agreed upon between purchaser and vendor at the time the contract or order is entered.

^⑤Angles are measured with protractors or with gauges. As illustrated, a four-point contact system is used, two contact points being as close to the angle vertex as practical, and the others near the ends of the respective surfaces forming the angle. Between these points of measurement surface flatness is the controlling tolerance.

^⑥When the space between the surfaces forming an angle is all metal, values in column 2 apply if the larger surface length to metal thickness ratio is 1 or less.

^⑦When two legs are involved the one having the larger ratio determines the applicable column.

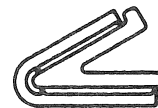

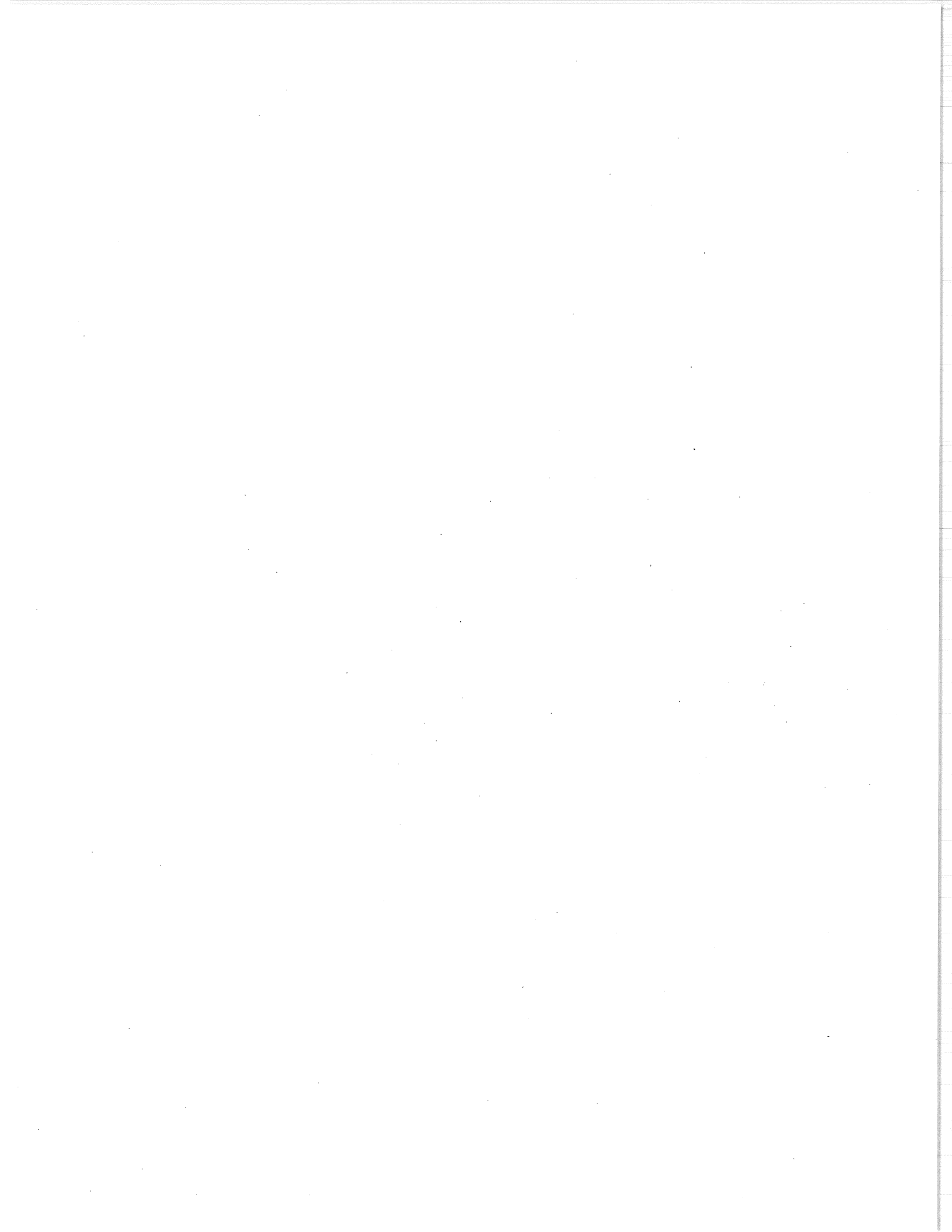

MATERIAL NAMES:

The standard used at Tek for naming parts is H6 (Cataloging Handbook). In some cases, the ASTM uses different names than H6. In such cases the H6 name will be used.

NAME	SHAPE
BAR	<p>(also Hex, Dodecagon, etc)</p>
ROD	DO NOT USE FOR METALS (Deleted from H6)
STRIP	
*WIRE & *ROD	<p>(also Hex, Dodecagon, etc)</p> <p>*Use WIRE for metal, and ROD for nonmetallic parts.</p>
SHEET	
FOIL & **FILM	<p>Use FOIL for metal, and FILM for nonmetallic parts.</p>

Some materials do not yet have specifications and may change without notice until the spec is finished. Also, some are exclusively used by one department and may be changed without notice by them.

ALUMINUM

SECTION 7 TABLE OF CONTENTS

	PAGE(S)
WIRE	7-2
BAR	7-2 & 7-3
FOIL	7-4
STRIP	7-4
SHEET	7-5
TUBE, SQUARE & RECTANGULAR	7-6
TUBE, ROUND	7-6
ALUMINUM WIRE CLOTH	7-6
ALUMINUM SILICON CASTING ALLOY	7-6
ALUMINUM ALLOY INGOT	7-6
CROSS REFERENCE INDEX	7-7 THRU 7-9
NOTES	7-9 & 7-29
ASTM B211	
MECHANICAL PROPERTIES	7-10
INDEX OF TABLES OF PERMISSIBLE VARIATIONS	7-10
TOLERANCES	7-11 THRU 7-13
ASTM B210	
MECHANICAL PROPERTIES	7-14
INDEX OF TABLES OF PERMISSIBLE VARIATIONS	7-14
TOLERANCES	7-14 THRU 7-17
ASTM B221	
MECHANICAL PROPERTIES	7-18
INDEX OF TABLES OF PERMISSIBLE VARIATIONS	7-18
TOLERANCES	7-18 THRU 7-21
ASTM B209	
MECHANICAL PROPERTIES	7-23
INDEX OF TABLES OF PERMISSIBLE VARIATIONS	7-22
TOLERANCES	7-24 THRU 7-27
ASTM B373	
FOIL TENSILE BREAKING LOAD	7-28
WEIGHT (LBS PER FT)	7-30 THRU 7-35

7

TEK STANDARDS PERTAINING TO MATERIALS

062-1702-00	Welding, Soldering & Brazing	D-100	Die Casting & Molding Standards
062-1703-00	Finishes, Glossary of Terms		
062-1713-00	Drafting, Aluminum Extrusions	H Series	Tooling Standards
062-1718-00	Finish Quality, Cosmetic		
062-2845-00	Mechanically Applied Finishes		
062-2848-00	Bend Allowance & Deduction	062-5818-01	Aluminum (M150)
062-2850-00	Finish, Surface Texture	M-200	Brass
062-2854-00	Finishes, Chemical & Electromechanical	M-250	Copper
062-2856-00	Non-Additive Finishes for Brass, Copper & Copper Alloys	M-300	Copper-Beryllium
062-2860-00	Finishes, Anodized	M-350	Beryllium-Nickel
062-2863-00	Zinc Die Cast Finishes, Chromate Conversion Coatings	M-400	Phosphor-Bronze
062-2868-00	Finish, Etch Chromate & Lacquer (On Aluminum)	M-450	Steel
062-2868-01	Chromate Conversion Coating for Al Die Casting Alloy 3431	M-500	Stainless Steel
062-2871-00	Finish, Passivating	M-550	Magnetic Shielding Materials (Iron-Nickel & Nickel-Silver)
062-5818-00	General Information about Bulk Raw Materials	M-600	Copper-Nickel-Zinc

ALUMINUM(CONT)

WIRE

* DESCRIPTION	ALLOY & TEMPER	SPECIFICATION ASTM*	PART NUMBER	CC/LB
.025 x .750 ±.005 x 12 ft long	5005-H14	B209	251-0075-03	I
.032 x 2 ft wide, (.1875 size of mesh) x 4 ft long	3003/5005-H14	B209	251-0154-00	I+/sf
.050 ±.004 x .530 ±.005 x 12 ft long	5005-H14 & H34	B209	251-0073-10	J+
.094 diameter round x 3 ft long	5556-H14	B211	251-0054-00	L-
.125 diameter x 12 ft long	2011-T3	B211	251-1168-00	J+
.125 diameter x 12 ft long	7075-T6	B211	251-1202-00	K-
.125 diameter x 12 ft long	6061-T6	B211	251-1341-00	J+
.156 diameter x 12 ft long	2011-T3	B211	251-0019-00	J+
.1875 diameter x 12 ft long	2024-T4	B211	251-1099-00	D /oz
.188 diameter x 12 ft long	6061-T6	B211	251-1723-00	J+
.188 diameter x 12 ft long	2011-T3	B211	251-0020-00	J+
.188 hexagon x 12 ft long	2017-T4	B211	251-1207-00	K
.250 diameter x 12 ft long	2011-T3	B211	251-0021-00	J+
.250 diameter x 12 ft long	6061-T6	B211	251-1091-00	J+
.250 diameter x 12 ft long	6262-T9	B211	251-0222-00	J-
.250 hexagon x 12 ft long	2011-T3	B211	251-0009-00	J+
.250 square x 12 ft long	2011-T3	B211	251-0005-00	K
.250 x .312 x 12 ft long	6061-T6	B211	251-1436-00	K-
.265 diameter ±.002 x 12 ft long	7075-T6	B211	251-1429-00	J+
.312 diameter x 12 ft long	6262-T9	B211	251-0022-00	J+
.312 hexagon x 12 ft long	2011-T3	B211	251-0101-00	J+
.312 square x 12 ft long	2024-T4	B211	251-0103-00	K+

BAR

* DESCRIPTION	ALLOY & TEMPER	SPECIFICATION ASTM*	PART NUMBER	CC/LB
.125 x .500 x 16 ft long	6063-T52	B221	251-0148-00	J+
.125 x .750 x 16 ft long	6063-T5	B221	251-0011-00	J
.125 x 1.500 x 12 ft long	2024-T4	B211	251-1087-00	L-
.188 x .500 x 12 ft long	2024-T4	B211	251-0087-00	K-
.200 x .385 x 12 ft long	6061-T6	B211	251-1335-00	J-
.250 x .375 x 6 ft long	6063-T6	B221	251-0253-00	J+
.250 ±.008 x .500 ±.000 -.005 x 14 ft 3 in long	6061-T6	B221	251-0174-00	I+
.250 x .500 x 12 ft long	6061-T6	B211	251-1437-00	J
.250 x .500 x 16 ft long	6063-T5	B221	251-0016-00	J-
.250 x .625 x 12 ft long	2024-T4	B211	251-0109-00	K
.250 x .750 x 12 ft long	6061-T6	B221	251-1273-00	J
.250 x 1.000 x 12 ft long	6061-T6	B221	251-0255-00	J-
.250 x 1.250 x 12 ft long	6061-T6	B221	251-1536-00	J-
.250 x 1.500 x 12 ft long	6061-T6511	B221	251-1211-00	J
.250 x 1.750 x 16 ft long	6063-T5	B221	251-0213-00	J+
.250 x 2.500 x 12 ft long	6061-T6511	B221	251-1212-00	J-
.250 x 2.500 x 12 ft long	6061-T6	B211	251-1443-00	J-
.250 x 7.500 ±.250 -.000 x 12 ft long +.4375 -.000	5052-H32	B209	251-0125-01	I+
.312 x .750 x 12 ft long	2024-T4	B221	251-0254-00	J+
.312 x 1.250 x 12 ft long	6061-T6	B221	251-1604-00	J-
.330 x .750 x 12 ft long	6061-T6	B211	251-1427-00	J-
.375 diameter x 12 ft long	2011-T3	B211	251-1001-00	J-
.375 diameter x 12 ft long	6063-T5	B221	251-1083-00	J+
.375 diameter x 12 ft long	6262-T9	B211	251-0023-00	J+
.375 hexagon x 12 ft long	6262-T9	B211	251-0175-00	J+
.375 square x 12 ft long	6061-T6	B211	251-0006-00	J+
.375 x .500 x 12 ft long	2024-T4	B211	251-0015-00	G
.375 x .750 x 12 ft long	6061-T6	B221	251-1092-00	J-
.375 x .750 x 12 ft long	6063-T5	B221	251-1027-00	J+
.375 x .875	6063-T6	B221	251-1677-00	K
.375 x 1.000 x 12 ft long	6063-T5	B221	251-1287-00	J-
.375 x 3.000 x 12 ft long	2024-T4	B221	251-1118-00	J+
.375 x 6.000 x 12 ft long	6061-T6	B209	251-1559-00	J-
.375 x 6.000 ±.0312 -.005 square	6061-T6	B209	251-1134-00	J+/ea
.375 x 8.000 x 9.250 in long	6061-T6	B209	251-1632-00	J+
.437 diameter x 12 ft long	6262-T9	B211	251-1081-00	J+
.437 diameter x 12 ft long	6063-T6	B221	251-0281-00	J+
.438 square x 12 ft long	2024-T4	B211	251-0158-00	K
.500 diameter x 12 ft long	2011-T3	B211	251-0024-00	J+
.500 diameter x 12 ft long	6262-T9	B211	251-0236-00	J+
.500 diameter x 12 ft long	7075-T6	B211	251-1188-00	J+
.500 hexagon x 12 ft long	2011-T3	B211	251-0010-00	J+
.500 square x 12 ft long	6061-T6511	B221	251-1144-00	J-
.500 x .750 x 12 ft long	6061-T6	B221	251-1355-00	J
.500 x 1.000 x 12 ft long	6061-T6	B221	251-0286-00	J-

ALUMINUM(CONT)

BAR (CONT)

* DESCRIPTION	ALLOY & TEMPER	SPECIFICATION ASTM*	PART NUMBER	CC/LB
.500 x 1.000 x 12 ft long	6061-T6	B221	251-1439-00	I+
.500 x 1.500 x 12 ft long	6061-T6	B221	251-1145-00	J-
.500 x 2.500 x 12 ft long	6061-T6	B221	251-0209-00	J-
.500 x 2.500 x 12 ft long	2024-T351	B221	251-1334-00	K-
.500 x 3.000 x 12 ft long	2024-T351	B221	251-1119-00	J+
.562 diameter x 12 ft long	2011-T3	B211	251-0025-00	J+
.562 diameter x 12 ft long	6262-T9	B211	251-0287-00	J+
.562 hexagon x 12 ft long	2011-T3	B211	251-0129-00	J+
.625 diameter x 12 ft long	2011-T3	B211	251-0127-00	J+
.625 diameter x 12 ft long	6262-T9	B211	251-0296-00	J+
.625 hexagon x 12 ft long	2011-T3	B211	251-1276-00	J+
.625 x 1.000 x 12 ft long	2024-T351	B211	251-1547-00	J+
.625 x 1.250 x 12 ft long	2024-T351	B211	251-1548-00	J+
.625 x 2.030 ±.005 x 2.610 ±.005	2024-T351	B209	251-1313-00	J+/ea
.625 x 8.250 x 8.250	6061-T6	B211	251-1702-00	J+
.650 x 1.000 x 12 ft long	6061-T6	B221	251-0249-00	I+/ft
.750 diameter x 12 ft long	6262-T9	B211	251-0074-00	J+
.750 diameter x 12 ft long	6061-T6	B211	251-0223-00	J+
.750 diameter x 12 ft long	7075-T6	B211	251-0248-00	J
.750 x .750 square x 12 ft long	2024-T4	B211	251-1459-00	J+
.750 x 2.500 x 12 ft long	6061-T6	B211	251-1440-01	I+
.750 x 2.500 x 12 ft long	2024-T351	B211	251-1483-00	J+
.750 x 3.675 + all -.000 x 12 ft long	6061-T6	B211	251-1440-00	J
.750 x 4.500 x 12 ft long	2024-T351	B221	251-1279-00	K-
.750 x 5.000 x 12.500 + all -.000	2024-T351	B221	251-1280-00	J+
.750 x 11.125 x 36.500 in long	6061-T6	B209	251-1657-00	J+
.812 diameter x 12 ft long	2011-T3	B211	251-0081-00	J
.875 diameter x 12 ft long	2011-T3	B211	251-0026-00	J
.875 diameter x 12 ft long	6061-T6	B211	251-1018-00	J
.875 x 1.250 x 12 ft long	6061-T6	B221	251-1537-00	J
1.000 diameter x 12 ft long	2011-T3	B211	251-0027-00	J+
1.000 hexagon x 12 ft long	6262-T9	B211	251-0284-00	J+
1.000 x 1.000 square x 12 ft long	6061-T6	B211	251-1602-00	J-
1.000 x 1.500 x 12 ft long	6061-T6	B221	251-1319-00	J-
1.000 ±.0025 x 2.000 ±.005 x 12 ft long	6063-T6	B221	251-1363-00	J-
1.000 x 3.000 x 12 ft long	2024-T4	B211	251-1359-00	J+
1.000 x 3.000 ±.008 x 12 ft long	2024-T351	B211	251-1389-00	J+
1.062 diameter x 12 ft long	6262-T9	B211	251-0152-00	J+
1.125 diameter x 12 ft long	6262-T9	B211	251-0289-00	J+
1.250 diameter x 12 ft long	2011-T3	B211	251-3013-00	J
1.250 square x 12 ft long	6061-T6511	B221	251-1204-00	J-
1.250 x 6.125 x 11.250 in long	7075-T651	B211	251-1571-00	J
1.375 diameter x 12 ft long	2011-T3	B211	251-1612-00	J
1.375 x 5.000 x 8.500 in long	6061-T6	B221	251-1607-00	J
1.500 diameter x 12 ft long	6262-T9	B211	251-0221-00	J+
1.625 diameter x 12 ft long	6262-T9	B211	251-0214-00	J+
1.750 x 2.250 x 8 ft long	6061-T6	B221	251-1597-00	K-
1.750 x 4.250 x 12 ft long	6061-T6	B221	251-1441-00	J-
2.000 diameter x 12 ft long	6262-T9	B221	251-1274-00	J
2.375 diameter x 12 ft long	6061-T6	B211	251-1638-00	J
2.625 diameter x 12 ft long	6061-T6	B211	251-1639-00	J

7

ULTRASONIC BOND WIRE
 .001 Diameter ±.0005, 80 ft on spool
 1 to 3% E long at 10N
 12 to 18 tensile strength
 251-1508-00 CC: F/ft

COST CODE (CC COLUMN)

CODE	A	B	C	D	E	F	G	H	I	J	K	L	M	N	O
≈ VALUE with +	.75¢	2¢	3.75¢	6¢	10¢	18¢	35¢	60¢	\$1	\$2	\$3.75	\$6	\$10	\$18	\$35+
≈ VALUE no suffix	.5¢	1.5¢	3¢	5¢	8¢	15¢	25¢	50¢	75¢	\$1.50	\$3	\$5	\$8	\$15	\$25
≈ VALUE with -	.2¢	1.25¢	2.5¢	4.25¢	7¢	13¢	22¢	40¢	65¢	\$1.25	\$2.50	\$4.25	\$7	\$13	\$22

NOTE: Costs may vary from order to order due to order quantities, vendor, etc.

ALUMINUM(CONT)

FOIL (ASTM B373) *

DESCRIPTION	ALLOY & TEMPER	PART NUMBER	CC/LB
.00020 x .500	1145-H19	251-0147-00	L
.00020 x .688	1145-H19	251-0200-00	L
.00020 x 4.000	Polyester Laminated	251-1283-00	J+
.00025 x .250	1145-H19	251-1022-00	G /oz
.00025 x .312	1145-H19	251-1275-00	J-
.00025 x .375	1145-H19	251-1047-00	F+/oz
.00025 x .562	1145-H19	251-1240-00	K-
.00025 x .625	1145-H19	251-0207-00	F /oz
.00025 x 1.000	1145-H19	251-0250-00	K-
.00025 x 1.500	1145-H19	251-0146-00	J+
.00025 x 2.000	1145-H19	251-0151-00	K-
.00040 x .500	1145-H19	251-0130-00	F /oz
.00040 x .625	1145-H19	251-0055-00	A /oz
.00040 x .875	1145-H19	251-0086-00	K-
.00040 x 1.000	1145-H19	251-0056-00	J+
.00040 x 2.000	1145-H19	251-0057-00	K-
.00300 x 6.720	Adhesive back 60 yd roll	251-1250-00	I-/yd

STRIP (ASTM B209)

DESCRIPTION	ALLOY & TEMPER	PART NUMBER	CC/LB
.025 x 1.832 Coil stock	5005-H34	251-0075-08	J-
.025 x 2.005 ±.005 Coil stock	5005-H34	251-0075-02	J-
.025 x 2.965 ±.005 Coil stock	5005-H34	251-0075-01	J-
.025 x 3.250 Coil stock	5005-H34	251-0075-07	J+
.025 x 4.875 Coil stock	5005-H34/H14	251-0075-04	J-
.025 x 5.500 Coil stock	5052-H34	251-1190-01	I+
.025 x 6.000 Coil stock	5005-H34/H14	251-0075-06	J-
.025 x 6.125 Coil stock	5005-H34	251-1253-00	J-
.032 x 5.000	5052-H32	251-1690-00	J-
.040 x 2.907 Coil stock	5005-H34/H14	251-0076-01	J-
.040 x 3.500 Coil stock	5052-H34	251-1596-00	J-
.040 x 4.125 Coil stock	5005-H34/H14	251-0076-03	I
.040 x 4.875 ±.005 Coil stock	5052-H34	251-0202-01	J
.040 x 6.000 Coil stock	5005-H34/H14	251-0076-04	J-
.040 x 7.150 Coil stock	5052-H34	251-0202-03	J-
.050 x 1.375 Coil stock	5052-H34	251-0179-02	J-
.050 x 1.555 Coil stock	5005-H34/H14	251-0073-07	J-
.050 x 2.375 Coil stock	5005-H34/H14	251-0073-04	J-
.050 x 4.250 Coil stock	5005-H34/H14	251-0073-06	J-
.050 x 6.312 Coil stock	5052-H34	251-0179-01	J-
.050 x 6.765 Coil stock	5005-H34/H14	251-0073-01	J-
.050 x 7.250 Coil stock	5005-H34/H14	251-0073-09	J-
.050 x 7.500 Coil stock	5005-H34/H14	251-0073-02	J-
.050 x 9.250 Coil stock	5052-H34	251-0179-03	J
.050 x 11.750 Coil stock	5005-H34/H14	251-0073-05	K
.063 x 1.840 Coil stock	5005-H34/H14	251-0077-05	J-
.063 x 2.250 ±.005 Coil stock	5052-H34	251-0180-03	J-
.063 x 4.500 Coil stock	5052-H34	251-0180-04	J-
.063 x 6.000 ±.010 Coil stock	5005-H34/H14	251-0077-04	J-
.063 x 6.625 dia cir	5005-0	251-0196-03	H /ea
.063 x 7.000 Coil stock	5005-H34	251-0077-01	G+
.063 x 7.875 dia cir	5005-0	251-0196-02	I /ea
.063 x 9.094 ±.0156 Coil stock	5005-H34	251-0077-02	H-
.063 x 9.500 Coil stock	5052-H34	251-0180-01	J-
.063 x 9.562 ±.0156 Coil stock	5005-H34/H14	251-0077-03	I
.080 x .700 Coil stock	5005-H34/H14	251-0078-05	I+
.080 x 2.550 Coil stock	5052-H32	251-1019-04	J
.080 x 2.625 Coil stock	5052-H32	251-1019-03	J-
.080 x 3.188 Coil stock	5005-H34/H14	251-0078-06	J-
.080 x 4.250 ±.000 -.010 Coil stock	5052-H32	251-1019-01	J-
.080 x 6.000 Coil stock	5005-H34/H14	251-0078-04	I+
.080 x 6.250 Coil stock	5052-H32	251-1019-02	J-
.080 x 8.000 Coil stock	5005-H34/H14	251-0078-03	I+
.090 x 3.750 Coil stock	5052-H32	251-0182-02	J-
.090 x 5.187 Coil stock	5052-H32	251-0182-03	J+
.090 x 9.750 Coil stock	5005-H34	251-0070-04	J-

ALUMINUM(CONT)

SHEET (ASTM B209) *

DESCRIPTION	ALLOY & TEMPER	PART NUMBER	CC/LB
.008 x 10 x 12 adhesive back, photo sensitive		251-1643-00	K /sh
.009 x 18 x 24 (lithograph)	1195	251-1642-00	J /sh
.016 x 36 x 108 (w/10% metal cladding both sides)	3003-H14	251-0145-00	J
.016 x 36 x 144	7075-T6	251-1348-00	K-
.020 x 48 x 48 (w/.010 black vinyl clad one side)	3003-H14	251-0225-00	I+/sf
.025 x 16 x 24	5052-H34	251-1190-02	
.025 x 36 x 96 (3.709 perforated & 2.781 blank section across sheet)	3003-H14	251-0053-00	A-/si
.025 x 36 x 108 (w/10% metal cladding both sides)	3003-H14	251-0028-00	J
.025 x 48 x 144	5005-H34	251-0075-00	J-
.025 x 48 x 144	5052-H34	251-1190-00	J-
.025 x 48 x 144	6061-T6	251-1063-00	J+
.032 x 16 x 24	5052-H32	251-1641-01	J+/ea
.032 x 17.265 ±.015 x 120 (w/.010 blue vinyl clad reverse side Bonderite #721 or #722)	5052-H32	251-1157-01	I+/sf
.032 x 48 x 144	5052-H32	251-1641-00	J-
.040 x 33.572 ±.010 x 148.500 (fine pebblegrain, depth of .003 +.002 -.001)	5052-H354	251-1227-00	J-
.040 x 34.125 (fine pebblegrain, depth of .003 +.002 -.001)	5052-H354	251-1227-01	I+
.040 x 44 x 108 (w/10% metal cladding both sides)	3003-H14	251-0108-00	J-
.040 x 48 x 144 (perforated .250 sq on .312 centers)	3003-H14	251-0100-00	B-/si
.040 x 48 x 144	5005-H34	251-0076-00	I+
.040 x 48 x 144	5052-H34	251-0202-00	J
.050 x 15.900 x 120 (w/.010 vinyl clad one side, coarse stipple grain Tek-tan, reverse side Bonderite #721)	5052-H34	251-0271-04	J-/sf
.050 x 15.900 x 120 (fine pebblegrain one side, depth .005 +.001 -.002)	5005-H134	251-0220-03	J+
.050 x 19.682 ±.005 x 146 +.250 -.000 (fine pebblegrain one side, depth .005 +.002 -.001)	5005-H134	251-0220-02	J
.050 x 20 (embossed pigskin, depth .003 +.002 -.001)	5005-H134	251-0220-07	I+
.050 x 26 x 127 (fluted, rib height .007)	5005-H134	251-0141-00	H+
.050 x 32.240 (embossed pigskin, depth .003 +.002 -.001)	5005-H134	251-0220-08	I+
.050 x 36 x 120 (perforated .188 dia on .250 centers)	3003-H14	251-1692-00	0+/sh
.050 x 36 x 120 (perforated .078 dia on .125 centers)	3003-H14	251-1446-00	J /sf
.050 x 36 x 96 (fine pebblegrain, depth .003 to .006)	5005-H134	251-0220-00	I+
.050 x 36 x 96 (fine pebblegrain, depth .003 to .006)	5005-H134	251-0220-09	I+
.050 x 36.500 x 130 (fluted, rib height .007)	5005-H134	251-0141-01	J-
.050 x 40 x 152 (fine pebblegrain, depth .005 +.002 -.001)	5005-H134	251-0113-02	I-
.050 x 42 x 148 (fine pebblegrain, depth .005 +.002 -.001)	5005-H134	251-0113-01	H
.050 x 44 x 108	3003-H14	251-0031-00	J
.050 x 48 x 120 (w/.010 vinyl clad one side, coarse stipple grain Tek-blue, reverse side Bonderite #721)	5052-H34	251-0271-03	I+/sf
.050 x 48 x 120 long (w/.010 vinyl clad one side, Tek medium tan, coarse stipple grain, reverse side Bonderite #721)	5052-H34	251-0271-06	J /sf
.050 x 48 x 120 (w/.010 vinyl clad one side, coarse stipple grain TV gray, reverse side Bonderite #721)	5052-H34	251-0271-05	J
.050 x 48 x 144	5005-H34/H14	251-0073-00	I+
.050 x 48 x 144	5052-H34	251-0179-00	J-
.050 x 48 x 144 (fluted, rib height .007)	5005-H134	251-0141-02	H+
.050 x 48 x 144 (fine pebblegrain, depth .005 +.002 -.001)	5005-H134	251-0113-00	J-
.063 x 13.250 Coil stock	5052-H34	251-0180-02	J-
.063 x 19.130 x 24.750 (perforated .078 dia holes on .312 centers)	5052-H32	251-1109-00	M-/ea
.063 x 38 x 152 (fine pebblegrain, depth .005 +.002 -.001)	5005-H134	251-0114-00	J-
.063 x 48 x 144	5005-0	251-0196-00	I /ea
.063 x 48 x 144	5005-H14	251-0077-00	J-
.063 x 48 x 144	3003-H14	251-1301-00	I+
.063 x 48 x 144	5052-H34	251-0180-00	I+
.063 x 48 x 144	6061-T6	251-0071-00	J-
.071 x 48 x 144	2024-T3	251-0066-00	J+
.080 x 42 x 148	5005-H34/H14	251-0078-02	I+
.080 x 46 x 142	5005-H34/H14	251-0078-01	I+
.080 x 48 x 48 (w/.010 black vinyl clad Haircell pattern one side)	3003-H14	251-1337-00	J+/sf
.080 x 48 x 108 (w/10% metal cladding)	3003-H14	251-0036-00	J-
.080 x 48 x 144	5005-H34/H14	251-0078-00	I+
.080 x 48 x 144	5052-H34	251-1019-00	J-
.090 x 48 x 144	5005-H14	251-0070-00	J
.090 x 48 x 144	5052-H32	251-0182-00	I+
.090 x 48 x 144	6061-T6	251-0195-00	I+
.100 x 48 x 144	5052-H32	251-0034-00	I+
.125 x 48 x 48 (w/.010 black vinyl clad Haircell pattern one side)	5052-H32	251-1102-00	J-/sf
.125 x 48 x 80	3003-H14	251-0038-00	J-
.125 x 48 x 144	2024-T4	251-1621-00	J+
.125 x 48 x 144	5052-H32	251-0072-00	J
.125 x 54 x 144	5052-H32	251-0072-01	I+
.190 x 48 x 144	5052-H32	251-1056-00	J-
.250 x 22.128 x 28.625 lb	6061-T6	251-1561-00	K-
.250 x 48 x 144	6061-T6	251-1305-00	J-
.250 x 48 x 144	5052-H32	251-0125-00	J-

7

ALUMINUM(CONT)

SQUARE AND RECTANGULAR TUBE (ASTM B221) *

DESCRIPTION	ALLOY & TEMPER	PART NUMBER	CC/LB
.624 square ID x .063 wall x 181.500 long +.250 -.000	6063-T4	251-0210-00	J-
.880 square ID x .060 wall x 102 ±.045 long	6063-T4	251-0231-00	H-/ft
1.000 x 1.500 x .125 wall	6063-T5	251-1284-00	J-/ft
1.000 x 2.000 rectangular x .125 wall x 21 long	6063-T5	251-0246-00	J-
1.000 x 3.000 x .125 wall	6063-T6	251-1558-00	J+
1.030 square ID x .050 wall	6063-T6	251-0285-00	J+
1.125 ±.012 x 3.000 ±.024 rectangular x .125 wall x 15.600 long	6061-T6	251-0295-00	K

ROUND TUBE *

DESCRIPTION	ALLOY & TEMPER	SPECIFICATION *	PART NUMBER	CC/LB
.089 ±.001 OD x .010 wall thickness	3003-H16	ASTM B210	251-0136-00	K /ft
.188 OD x .049 wall thickness	6061-T6	ASTM B210	251-0039-00	L
.250 OD x .035 wall thickness	6061-T6	ASTM B210	251-0040-00	L
.250 OD x .058 wall thickness	6061-T6	ASTM B210	251-0099-00	L
.312 OD x .058 wall thickness	6061-T6	ASTM B210	251-0041-00	L-
.312 OD x .028 wall thickness	6061-T6	ASTM B210	251-1239-00	G+/ft
.375 OD ±.003 x 125 wall thickness -.000 +.008 x 12 ft long	2024-T3	ASTM B210	251-0096-00	M-
.375 OD x .065 wall thickness	6061-T6	ASTM B210	251-0042-00	K
.375 OD x .028 wall thickness	7075-T6	ASTM B210	251-0155-00	H+/ft
.500 OD x .028 wall thickness	6061-T6	ASTM B210	251-0043-00	L-
.500 OD x .058 wall thickness x 12 ft long	6061-T6	ASTM B210	251-0085-00	K
.500 OD x .095 wall thickness x 12 ft long	2024-T3	ASTM B210	251-1187-00	J-/ft
.625 OD x .035 wall thickness x 12 ft long	6061-T6	ASTM B210	251-0089-00	K-
.625 OD x .058 wall thickness	6061-T6	ASTM B210	251-0044-00	K-
.625 OD ±.004 x .028 wall thickness x 12 ft long	6061-T6	ASTM B210	251-0153-00	M+
.750 OD x .035 wall thickness x 12 ft long	6061-T6	ASTM B210	251-0233-00	I-/ft
1.125 OD x .250 wall thickness	6061-T6	ASTM B210	251-1311-00	L-/ft
1.250 OD x .049 wall thickness x 12 ft long	6061-T6	ASTM B221	251-1358-00	J+/ft
1.375 OD x .058 wall thickness	6061-T6	ASTM B210	251-1400-00	H /ft
1.500 OD x .049 wall thickness ±.003	6061-T6	ASTM B210	251-0112-00	K-
1.500 OD ±.005 x .065 wall thickness ±.004 x 12 ft long	6061-T6	ASTM B210	251-0167-00	J+
1.500 OD x .125 wall thickness x 12 ft, 6 inches long	6061-T6	ASTM B210	251-1381-00	J+
1.900 OD x .145 wall thickness x 20 ft long	6061-T6	ASTM B221	251-1356-00	J+/ft
2.250 OD x .065 wall thickness x 12 ft long	6061-T6	ASTM B221	251-1357-00	K-/ft
2.250 OD x .312 wall thickness x 12 ft long	6061-T6	ASTM B210	251-1286-00	M+/ft
3.000 OD x .065 wall thickness x 12 ft long	6061-T6	ASTM B210	251-0131-00	F-/in
3.000 OD x .250 wall thickness x 12 ft long	6061-T6	ASTM B210	251-1542-00	L /ft
3.000 OD x .750 wall thickness x 12 ft long	6061-T6	ASTM B210	251-1543-00	M+/ft
3.765 OD ±.016 x .150 ±.010 wall thickness x 12 ft long	6061-T6	ASTM B221	251-1251-00	K+

ALUMINUM WIRE CLOTH

.020 dia wire, .097 in openings, 36 in wide
251-0235-00 CC: K+/ft

ALUMINUM SILICON CASTING ALLOY

Bulk, Alloy - A356, ASTM B179 251-1026-00 I/1b
 Bulk, Alloy - A380, ASTM B179 251-1036-00 I/1b

CC:

ALUMINUM ALLOY INGOT

Alloy - SC114A (except 2% - 3% zinc)
 ASTM B179 251-1080-00 CC: I-/1b

COST CODE (CC COLUMN)

CODE	A	B	C	D	E	F	G	H	I	J	K	L	M	N	O
≈ VALUE with +	.75¢	2¢	3.75¢	6¢	10¢	18¢	35¢	60¢	\$1	\$2	\$3.75	\$6	\$10	\$18	\$35+
≈ VALUE no suffix	.5¢	1.5¢	3¢	5¢	8¢	15¢	25¢	50¢	75¢	\$1.50	\$3	\$5	\$8	\$15	\$25
≈ VALUE with -	.2¢	1.25¢	2.5¢	4.25¢	7¢	13¢	22¢	40¢	65¢	\$1.25	\$2.50	\$4.25	\$7	\$13	\$22

NOTE: Costs may vary from order to order due to order quantities, vendor, etc.

* The full text of these ASTM's is available for review at 78-567, or for more information, call Norma, Ext. 2577, or Bella Geotina, Ext. 2315. For Tolerances and Mechanical Properties, see Pages 7-10 thru 7-28.

CROSS REFERENCE INDEX

ALUMINUM (EXCEPT EXTRUSIONS)

PART NUMBER	DESCRIPTION	SIZE	PAGE NO.	STATUS§§	PART NUMBER	DESCRIPTION	SIZE	PAGE NO.	STATUS§§
251-0005-00	Wire	.250 sq	7-2	CR	251-0078-03	Strip	.080 x 8.000 Coil stock	7-4	CR
251-0006-00	Bar	.375 sq	7-2	CR	251-0078-04	Strip	.080 x 6.000 Coil stock	7-4	CR
251-0009-00	Wire	.250 hex	7-2	CR	251-0078-05	Strip	.080 x .700 Coil stock	7-4	CS
251-0010-00	Bar	.500 hex	7-2	CR	251-0078-06	Strip	.080 x 3.188 Coil stock	7-4	CR
251-0011-00	Bar	.125 x .750	7-2	CR	251-0081-00	Bar	.812 dia	7-3	CR
251-0015-00	Bar	.375 x .500	7-2	CR	251-0085-00	Tube	.500 OD	7-6	CR
251-0016-00	Bar	.250 x .500	7-2	CR	251-0086-00	Foil	.00040 x .875	7-4	CR
251-0019-00	Wire	.156 dia	7-2	XE	251-0087-00	Bar	.188 x .500	7-2	CR
251-0020-00	Wire	.188 dia	7-2	CR	251-0089-00	Tube	.625 OD	7-6	CR
251-0021-00	Wire	.250 dia	7-2	CR	251-0096-00	Tube	.375 OD	7-6	CR
251-0022-00	Wire	.312 dia	7-2	CR	251-0099-00	Tube	.250 OD	7-6	CR
251-0023-00	Bar	.375 dia	7-2	CR	251-0100-00	Sheet	.040 x 48. x 144.	7-5	CR
251-0024-00	Bar	.500 dia	7-2	CR	251-0101-00	Wire	.312 hex	7-2	CR
251-0025-00	Bar	.562 dia	7-3	CR	251-0103-00	Wire	.312 sq	7-2	CR
251-0026-00	Bar	.875 dia	7-3	CS	251-0108-00	Sheet	.040 x 44. x 108.	7-5	CR
251-0027-00	Bar	1.000 dia	7-3	CR	251-0109-00	Bar	.250 x .625	7-2	CR
251-0028-00	Sheet	.025 x 36. x 108.	7-5	CR	251-0112-00	Tube	1.500 OD	7-6	CS
251-0031-00	Sheet	.050 x 44. x 108.	7-5	CR	251-0113-00	Sheet	.050 x 48. x 144.	7-5	CR
251-0034-00	Sheet	.100 x 48. x 144.	7-5	CR	251-0113-01	Sheet	.050 x 42. x 148.	7-5	CS
251-0036-00	Sheet	.080 x 48. x 108.	7-5	CR	251-0113-02	Sheet	.050 x 40. x 152.	7-5	CS
251-0038-00	Sheet	.125 x 48. x 80.	7-5	CR	251-0114-00	Sheet	.063 x 38. x 152.	7-5	CR
251-0039-00	Tube	1.888 OD	7-6	CR	251-0125-00	Sheet	.250 x 48. x 144.	7-5	CR
251-0040-00	Tube	.250 OD	7-6	CR	251-0125-01	Bar	.250 x 7.500	7-2	CR
251-0041-00	Tube	.312 OD	7-6	CR	251-0127-00	Bar	.625 dia	7-3	CR
251-0042-00	Tube	.375 OD	7-6	CR	251-0129-00	Bar	.562 hex	7-3	CR
251-0043-00	Tube	.500 OD	7-6	CS	251-0130-00	Foil	.00040 x .500	7-4	CR
251-0044-00	Tube	.625 OD	7-6	CR	251-0131-00	Tube	3.000 OD	7-6	CS
251-0053-00	Sheet	.025 x 36. x 96.	7-5	CS	251-0136-00	Tube	.089 OD	7-6	CR
251-0054-00	Wire	.094 dia round	7-2	CR	251-0141-00	Sheet	.050 x 26. x .127	7-5	CR
251-0055-00	Foil	.00040 x .625	7-4	CR	251-0141-01	Sheet	.050 x 36.500 x 130.	7-5	CR
251-0056-00	Foil	.00040 x 1.000	7-4	CS	251-0141-02	Sheet	.050 x 48. x 144.	7-5	CR
251-0057-00	Foil	.00040 x 2.000	7-4	CR	251-0145-00	Sheet	.016 x 36.000 x 108.	7-5	CR
251-0066-00	Sheet	.071 x 48. x 144.	7-5	CR	251-0146-00	Foil	.00025 x 1.500	7-4	CR
251-0070-00	Sheet	.090 x 48. x 144.	7-5	CR	251-0147-00	Foil	.00020 x .500	7-4	CR
251-0070-01	Strip	.090 x 6.750 Coil stock		NP	251-0148-00	Bar	.125 x .500	7-2	CR
251-0070-02	Strip	.090 x 12.000 Coil stock		NP	251-0151-00	Foil	.00025 x 2.000	7-4	CR
251-0070-03	Sheet	.090 x 17.625 x 146.		NP	251-0152-00	Bar	1.062 dia	7-3	CR
251-0070-04	Strip	.090 x 9.750 Coil stock	7-4	CR	251-0153-00	Tube	.625 OD	7-6	CR
251-0071-00	Sheet	.063 x 48. x 144	7-5	CR	251-0154-00	Wire	.032 x 2.000	7-2	CR
251-0072-00	Sheet	.125 x 48. x 144.	7-5	CR	251-0155-00	Tube	.375 OD	7-6	CR
251-0072-01	Sheet	.125 x 54. x 144	7-5	CR	251-0158-00	Bar	.438 sq	7-2	CR
251-0073-00	Sheet	.050 x 48. x 144.	7-5	CR	251-0167-00	Tube	1.500 OD	7-6	CR
251-0073-01	Strip	.050 x 6.765 Coil stock	7-4	CR	251-0174-00	Bar	.250 x .500	7-2	CS
251-0073-02	Strip	.050 x 7.500 Coil stock	7-4	CR	251-0175-00	Bar	.375 hex	7-2	CR
251-0073-03	Strip	.050 x 13.000	7-4	DL	251-0179-00	Sheet	.050 x 48. x 144.	7-5	CR
251-0073-04	Strip	.050 x 2.375 Coil stock	7-4	CR	251-0179-01	Strip	.050 x 6.312 Coil stock	7-4	CR
251-0073-05	Strip	.050 x 11.750 Coil stock	7-4	CR	251-0179-02	Strip	.050 x 1.375 Coil stock	7-4	CR
251-0073-06	Strip	.050 x 4.250 Coil stock	7-4	CR	251-0179-03	Strip	.050 x 9.250 Coil stock	7-4	CR
251-0073-07	Strip	.050 x 1.555 Coil stock	7-4	CR	251-0180-00	Sheet	.063 x 48. x 144.	7-5	CR
251-0073-08	Strip	.050 x 7.000 Coil stock		DL	251-0180-01	Strip	.063 x 9.500 Coil stock	7-4	CR
251-0073-09	Strip	.050 x 7.250 Coil stock	7-4	CR	251-0180-02	Sheet	.063 x 13.250 Coil stock	7-5	CR
251-0073-10	Wire	.050 x .530	7-2	CR	251-0180-03	Strip	.063 x 2.250 Coil stock	7-4	CR
251-0074-00	Bar	.750 dia	7-3	CR	251-0180-04	Strip	.063 x 4.500 Coil stock	7-4	CR
251-0075-00	Sheet	.025 x 48. x 144.	7-5	CR	251-0182-00	Sheet	.090 x 48. x 144.	7-5	CR
251-0075-01	Strip	.025 x 2.965 Coil stock	7-4	CR	251-0182-01	Sheet	.090 x 21. x 142.		DL
251-0075-02	Strip	.025 x 2.005	7-4	CR	251-0182-02	Strip	.090 x 3.750 Coil stock	7-4	CR
251-0075-03	Wire	.250 x .750 Coil stock	7-2	CR	251-0182-03	Strip	.090 x 5.187 Coil stock	7-4	MP
251-0075-04	Strip	.025 x 4.875 Coil stock	7-4	CR	251-0195-00	Sheet	.090 x 48. x 144.	7-5	CR
251-0075-06	Strip	.025 x 6.000 Coil stock	7-4	CR	251-0196-00	Sheet	.063 x 48. x 144.	7-5	CR
251-0075-07	Strip	.025 x 3.250 Coil stock	7-4	CR	251-0196-01	Strip	.063 x 9.500 dia cir		DL
251-0075-08	Strip	.025 x 1.832 Coil stock	7-4	CR	251-0196-02	Strip	.063 x 7.875 dia cir	7-4	CS
251-0076-00	Sheet	.040 x 48. x 144.	7-5	CR	251-0196-03	Strip	.063 x 6.625 dia cir	7-4	CR
251-0076-01	Strip	.040 x 2.907 Coil stock	7-4	CR	251-0196-05	Sheet	.063 x 12.437		NP
251-0076-02	Strip	.040 x 2.520 Coil stock		DL	251-0200-00	Foil	.00020 x .688	7-4	CR
251-0076-03	Strip	.040 x 4.125 Coil stock	7-4	CR	251-0202-00	Sheet	.040 x 48. x 144.	7-5	CR
251-0076-04	Strip	.040 x 6.000 Coil stock	7-4	CR	251-0202-01	Strip	.040 x 4.875 Coil stock	7-4	CR
251-0077-00	Sheet	.063 x 48. x 144.	7-5	CR	251-0202-02	Strip	.040 x 6.000 Coil stock		DL
251-0077-01	Strip	.063 x 7.000 Coil stock	7-4	CS	251-0202-03	Strip	.040 x 7.150 Coil stock	7-4	PP
251-0077-02	Strip	.063 x 9.094 Coil stock	7-4	OB	251-0207-00	Foil	.00025 x .625	7-4	CR
251-0077-03	Strip	.063 x 9.562 Coil stock	7-4	CR	251-0209-00	Bar	.500 x 2.500	7-3	CR
251-0077-04	Strip	.063 x 6.000 Coil stock	7-4	CR	251-0210-00	Tube	.624 sq ID	7-6	CR
251-0077-05	Strip	.063 x 1.840 Coil stock	7-4	CR	251-0210-02	Tube	.625 sq ID		NP
251-0078-00	Sheet	.080 x 48. x 144.	7-5	CR	251-0213-00	Bar	.250 x 1.750	7-2	CR
251-0078-01	Sheet	.080 x 46. x 142.	7-5	CR	251-0214-00	Bar	1.625 dia	7-3	CR
251-0078-02	Sheet	.080 x 42. x 148.	7-5	CR	251-0220-00	Sheet	.050 x 36. x 96.	7-5	CR

7

CROSS REFERENCE INDEX (CONT)

ALUMINUM (EXCEPT EXTRUSIONS)

PART NUMBER	DESCRIPTION	SIZE	PAGE NO.	STATUS§§	PART NUMBER	DESCRIPTION	SIZE	PAGE NO.	STATUS§§
251-0220-01	Strip	.050 x 5.250		NP	251-1207-00	Wire	.188 Hex	7-2	CR
251-0220-02	Sheet	.050 x 19.730 x 146.	7-5	CR	251-1211-00	Bar	.250 x 1.500	7-2	CR
251-0220-03	Sheet	.050 x 15.900 x 120.	7-5	CR	251-1212-00	Bar	.250 x 2.500	7-2	CR
251-0220-06	Wire	.050 x 1.000		NP	251-1227-00	Sheet	.040 x 33.572 x 148.500	7-5	CR
251-0220-07	Sheet	.050 x 20.000	7-5	CR	251-1227-01	Sheet	.040 x 34.125	7-5	CR
251-0220-08	Sheet	.050 x 32.240	7-5	CR	251-1239-00	Tube	.312 OD	7-6	CR
251-0220-09	Sheet	.050 x 36. x 96.	7-5	CR	251-1240-00	Foil	.00025 x .562	7-4	CR
251-0221-00	Bar	1.500 dia	7-3	CR	251-1250-00	Foil	.003 x 6.720	7-4	CR
251-0222-00	Wire	.250 dia	7-2	CR	251-1251-00	Tube	3.765 OD	7-6	CS
251-0223-00	Bar	.750 dia	7-3	CR	251-1253-00	Strip	.025 x 6.125 Coil stock	7-4	CR
251-0225-00	Sheet	.020 x 48. x 48.	7-5	CR	251-1273-00	Bar	.250 x .750	7-2	CR
251-0231-00	Tube	.880 sq ID	7-6	CR	251-1274-00	Bar	2.000 dia	7-3	CS
251-0233-00	Tube	.750 OD	7-6	CR	251-1275-00	Foil	.00025 x .312	7-4	CR
251-0235-00	Wire Cloth	.020 dia wire	7-6	CS	251-1276-00	Bar	.625 hex	7-3	CR
251-0236-00	Bar	.500 dia	7-2	CR	251-1277-00	Tube	.884 sq ID		DL
251-0246-00	Tube	1.000 x 2.000 rect. OD	7-6	CR	251-1279-00	Bar	.750 x 4.500	7-3	CR
251-0248-00	Bar	.750 dia	7-3	CR	251-1280-00	Bar	.750 x 5.000 x 12.500	7-3	CR
251-0249-00	Bar	.650 x 1.000	7-3	CR	251-1283-00	Foil	.00020 x 4.000	7-4	CR
251-0250-00	Foil	.00025 x 1.000	7-4	CR	251-1284-00	Tube	1.000 x 1.500	7-6	CR
251-0253-00	Bar	.250 x .375	7-2	CR	251-1286-00	Tube	2.250 OD	7-6	CS
251-0254-00	Bar	.312 x .750	7-2	CR	251-1287-00	Bar	.375 x 1.000	7-2	CR
251-0255-00	Bar	.250 x 1.000	7-2	CR	251-1301-00	Sheet	.063 x 48. x 144.	7-5	CR
251-0271-00	Sheet	.050 x 15.900 x 120.		NP	251-1305-00	Sheet	.250 x 48. x 144.	7-5	CR
251-0271-03	Sheet	.050 x 48. x 120.	7-5	CR	251-1311-00	Tube	1.125 OD	7-6	CR
251-0271-04	Sheet	.050 x 15.900 x 120.	7-5	CR	251-1313-00	Bar	.625 x 2.030 x 2.610	7-3	CR
251-0271-05	Sheet	.050 x 48. x 120.	7-5	CR	251-1319-00	Bar	1.000 x 1.500	7-3	CR
251-0271-06	Sheet	.050 x 48. x 120.	7-5	CR	251-1334-00	Bar	.500 x 2.500	7-3	CR
251-0281-00	Bar	.437 dia	7-2	CR	251-1335-00	Bar	.200 x .385	7-2	CR
251-0284-00	Bar	1.000 hex	7-3	OT	251-1337-00	Sheet	.080 x 48. x 48.	7-5	OT
251-0285-00	Tube	1.030 sq ID	7-6	CS	251-1341-00	Wire	.125 dia	7-2	CR
251-0286-00	Bar	.500 x 1.000	7-2	CR	251-1348-00	Sheet	.016 x 36. x 144.	7-5	CR
251-0287-00	Bar	.750 dia	7-3	CR	251-1355-00	Bar	.500 x .750	7-2	CR
251-0289-00	Bar	1.000 dia	7-3	CR	251-1356-00	Tube	1.900 OD	7-6	CR
251-0295-00	Tube	1.125 x 3.000 rect. OD	7-6	CR	251-1357-00	Tube	2.250 OD	7-6	CR
251-0296-00	Bar	.625 dia	7-3	CR	251-1358-00	Tube	1.250 OD	7-6	CR
251-1001-00	Bar	.375 dia	7-2	CR	251-1359-00	Bar	1.000 x 3.000	7-3	CR
251-1018-00	Bar	.875 dia	7-3	CR	251-1363-00	Bar	1.000 x 2.000	7-3	CR
251-1019-00	Sheet	.080 x 48. x 144.	7-5	CR	251-1378-00	Cast Alloy	1.500 OD		DL
251-1019-01	Strip	.080 x 4.250 Coil stock	7-4	CR	251-1381-00	Tube	1.500 OD	7-6	CR
251-1019-02	Strip	.080 x 6.250 Coil stock	7-4	OT	251-1389-00	Bar	1.000 x 3.000	7-3	CR
251-1019-03	Strip	.080 x 2.625 Coil stock	7-4	CR	251-1400-00	Tube	1.375 OD	7-6	CS
251-1019-04	Strip	.080 x 2.550 Coil stock	7-4	MP	251-1422-00	Tube	1.375 OD		DL
251-1022-00	Foil	.00025 x .250	7-4	CR	251-1426-00	Tube	.094 OD		DL
251-1026-00	Si Cast Alloy		7-6	CR	251-1427-00	Bar	.330 x .750	7-2	OT
251-1027-00	Bar	.375 x .750	7-2	CR	251-1429-00	Wire	.265 dia	7-2	CR
251-1036-00	Si Cast Alloy		7-6	CR	251-1436-00	Wire	.250 x .312	7-2	CR
251-1047-00	Foil	.00025 x .375	7-4	CR	251-1437-00	Bar	.250 x .500	7-2	CR
251-1055-00	Wire	.062 x .165		LR	251-1438-00	Bar	.438 x 2.000		DL
251-1056-00	Sheet	.190 x 48. x 144.	7-5	CR	251-1439-00	Bar	.500 x 1.000	7-3	CR
251-1063-00	Sheet	.025 x 48. x 144.	7-5	CR	251-1440-00	Bar	.750 x 3.675	7-3	CR
251-1080-00	Ingot		7-6	CR	251-1440-01	Bar	.750 x 2.500	7-3	CR
251-1081-00	Bar	.437 dia	7-2	CR	251-1441-00	Bar	1.750 x 4.250	7-3	CR
251-1083-00	Bar	.375 dia	7-2	CR	251-1442-00	Bar	.188 x .375		DL
251-1087-00	Bar	.125 x 1.500	7-2	CR	251-1443-00	Bar	.250 x 2.500	7-2	CR
251-1091-00	Wire	.250 dia	7-2	CR	251-1446-00	Sheet	.050 x 36.000	7-5	CR
251-1092-00	Bar	.375 x .750	7-2	CR	251-1459-00	Bar	.750 x .750 sq	7-3	CR
251-1096-00	Wire	.132 dia		DL	251-1483-00	Bar	.750 x 2.500	7-3	CR
251-1099-00	Wire	.1875 dia	7-2	OB	251-1508-00	Wire	.0001 dia	7-3	CR
251-1102-00	Sheet	.125 x 48. x 48.	7-5	CS	251-1535-00	Bat	1.500 hex		DL
251-1107-00	Sheet	.050 x 48. x 120.		NP	251-1536-00	Bar	.250 x 1.250	7-2	CR
251-1109-00	Sheet	.063 x 19.130 x 24.750	7-5	CR	251-1537-00	Bar	.875 x 1.250	7-3	PP
251-1118-00	Bar	.375 x 3.000	7-2	CR	251-1539-00	Sheet	.375 x 48.000		DL
251-1119-00	Bar	.500 x 3.000	7-3	CR	251-1542-00	Tube	3.000 x .250	7-6	CR
251-1128-00	Sheet	.062 x 48. x 120.		NP	251-1543-00	Tube	3.000 x .750	7-6	CR
251-1134-00	Bar	.375 x 6.000	7-2	CS	251-1547-00	Bar	.625 x 1.000	7-3	CR
251-1144-00	Bar	.500 sq	7-2	CR	251-1548-00	Bar	.625 x 1.250	7-3	CR
251-1145-00	Bar	.500 x 1.500	7-3	CR	251-1558-00	Tube	1.000 x 3.000	7-6	CR
251-1157-01	Sheet	.032 x 17.265 x 120.	7-5	CR	251-1559-00	Bar	.375 x 6.000	7-2	PP
251-1168-00	Wire	.125 dia	7-2	CR	251-1561-00	Sheet	.250 x 22.128 x 28.625	7-5	CR
251-1187-00	Tube	.500 OD	7-6	CS	251-1571-00	Bar	1.250 x 6.125	7-3	CR
251-1188-00	Bar	.500 dia	7-2	CR	251-1595-00	Round Tube	1.125 x .125		DL
251-1190-00	Sheet	.025 x 48. x 144.	7-5	CR	251-1596-00	Strip	.040 x 3.500 Coil stock	7-4	CR
251-1190-01	Strip	.025 x 5.500 Coil stock	7-4	CR	251-1597-00	Bar	1.750 x 2.250	7-3	CR
251-1190-02	Sheet	.025 x 16. x 24.	7-5	PP	251-1602-00	Bar	1.000 x 1.000 sq	7-3	CR
251-1202-00	Wire	.125 dia	7-2	CR	251-1603-00	Bar	.125 x 1.000		DL
251-1204-00	Bar	1.250 sq	7-3	OT					

CROSS REFERENCE INDEX (CONT)

ALUMINUM (EXCEPT EXTRUSIONS)

PART NUMBER	DESCRIPTION	SIZE	PAGE NO.	STATUS§§
251-1604-00	Bar	.312 x 1.250	7-2	CR
251-1607-00	Bar	1.375 x 5.000	7-3	CR
251-1612-00	Bar	1.375 dia	7-3	PP
251-1621-00	Sheet	.125 x 48. x 144.	7-5	CR
251-1632-00	Bar	.375 x 8.000	7-2	CR
251-1638-00	Bar	2.375 dia	7-3	CR
251-1639-00	Bar	2.625 dia	7-3	CR
251-1641-00	Sheet	.032 x 48. x 144.	7-5	CR
251-1641-01	Sheet	.032 x 16. x 24.	7-5	CR
251-1642-00	Sheet	.009 x 18. x 24.	7-5	CR
251-1643-00	Sheet	.008 x 10. x 12.	7-5	CR
251-1657-00	Bar	.750 x 11.125	7-3	PP
251-1674-00	Bar	.875 dia		DL
251-1677-00	Bar	.375 x .875	7-3	PP
251-1690-00	Strip	.032 x 5.000	7-4	CR
251-1692-00	Sheet	.050 x 36. x 120.	7-5	CR
251-1702-00	Bar	.625 x 8.250 x 8.250	7-3	PP
251-1723-00	Wire	.188 dia	7-2	CR
251-3000-00	Bar	1.250 x 6.125		DL
251-3013-00	Bar	1.250 dia	7-3	CR
251-3050-00	Bar	1.000 dia		DL

§§ STATUS CODES

CR	Current Production
EN	Engineering
PP	Pre-Production
CS	Customer Service
NP	Non-Production
DL	Deleted
OB	Obsolete Instrument
CM	Custom Mod Instrument
DS	Digital Systems
OT	Obsolescent Instrument
MP	Modified Part
LR	Last Supply Current
LS	Last Supply Customer Service
VN	Vendor
TC	Tequipment Current Production
IN	International
SC	Sony/Tek Current Production

THE STATUS IN THIS CATALOG WAS CORRECT AT THE TIME IT WAS PUBLISHED, BUT IT IS SUBJECT TO CHANGE.

§ TO USE A PART WITH THIS STATUS ON A NEW INSTRUMENT REQUIRES THAT A NEW PURCHASED PART INITIATION FORM (PPIF) BE INITIATED.

(A GLOSSARY OF TERMS FOR THESE STATUS CODES CAN BE FOUND ON PAGE 0-10).

NOTES

ALUMINUM(CONT)

MECHANICAL PROPERTIES & TOLERANCES (PER ASTM B211)

ALLOY	TEMPER	DISTANCE ACROSS FLATS	TENSILE STRENGTH KSI* (MIN)	YIELD STRENGTH KSI* (MIN)	ELONGATION IN 2 IN OR 4 x DISTANCE ACROSS FLATS, (%), MIN
2011	T3	.125-1.500	45	38	10
		1.501-2.000	43	34	12
		2.001-3.250	42	30	14
2024	T4	.124 & under	62		-
		.125-.499	62	45	10
		.500-4.500	62	42	10
		4.501-6.500	62	40	10
		6.501-8.000	58	38	10
		.500-6.500	62	45	10
5052	T351	.500-6.500	62	45	10
	H34	.374 & under	34	26	-
5056	H14		57		
6061	T6	.125-8.	42	35	10
6262	T6	.125-8.	42	35	10
6262	T9	.125-2.	52	48	5
		2. -3.	50	46	5
7075	T6	.125-4.	77	66	7

INDEX TO TABLES OF PERMISSIBLE VARIATION OF ANSI H35.2 (PER ASTM B211)

TABLE NO.	TITLE
9.1	Diameter, Round Wire and Rod
9.2	Diameter, Centerless Ground Round Wire & Rod
9.3	Diameter, Rivet & Cold Heading Wire & Rod
9.4	Diameter, Redraw Rod
9.5	Thickness and Width, Rectangular Wire and Bar
9.6	Distance Across Flats, Square, Hexagonal and Octagonal Wire and Bar
9.7	Thickness and Width, Flattened and Slit Wire
9.8	Thickness and Width, Flattened and Slit Wire
9.9	Thickness and Width, Rough Rolled Round Cornered Square and Rectangular Bar
9.10	Length, Specific and Multiple
9.11	Twist, Bar in Straight Lengths
9.12	Straightness, Rod and Bar in Straight Lengths
9.13	Straightness, Screw Machine Stock
9.14	Flatness (Flat Surfaces)
9.15	Angularity
9.16	Squareness of Saw Cuts

ALUMINUM(CONT)

PERMISSIBLE VARIATION OF ANSI H35.2(PER ASTM B211)

9. wire, rod and bar—rolled or cold-finished

9.1 • DIAMETER ROUND WIRE AND ROD

SPECIFIED DIAMETER in.	TOLERANCE—in. Plus and Minus Except as Noted			
	ALLOWABLE DEVIATION FROM SPECIFIED DIAMETER			
	Drawn Wire	Cold Finished Rod	Rolled Rod	
Plus			Minus	
Up thru 0.035	.0005
0.036-0.064	.001
0.065-0.374	.0015
0.375-0.5000015
0.501-1.000002
1.001-1.5000025
1.501-2.000004	.006	.006
2.001-3.000006	.008	.008
3.001-3.499008	.012	.012
3.500-5.000012	.031	.016
5.001-8.000062	.031

9.2 • DIAMETER CENTERLESS GROUND ROUND WIRE AND ROD

SPECIFIED DIAMETER in.	TOLERANCE in. Plus and Minus
	ALLOWABLE DEVIATION FROM SPECIFIED DIAMETER
0.125-0.625	.0005
0.626-1.500	.0010
1.501-2.000	.0025

9.3 • DIAMETER RIVET AND COLD HEADING WIRE AND ROD

SPECIFIED DIAMETER in.	TOLERANCE			
	ALLOWABLE DEVIATION FROM SPECIFIED DIAMETER			
	Rivet Wire		Rivet Rod	
	in. Plus	in. Minus	in. Plus	in. Minus
Up thru 0.061	.0005	.0005
0.062-0.123	.001	.0005
0.124-0.154	.001	.001
0.155-0.374	.002	.001
0.375-0.500002	.001
0.501-1.000003	.001

9.4 • DIAMETER REDRAW ROD

SPECIFIED DIAMETER in.	TOLERANCE—in. Plus and Minus
	ALLOWABLE DEVIATION FROM SPECIFIED DIAMETER
0.375	.020

9.5 • THICKNESS AND WIDTH RECTANGULAR WIRE AND BAR

SPECIFIED THICKNESS OR WIDTH in.	TOLERANCE in. Plus and Minus			
	ALLOWABLE DEVIATION FROM SPECIFIED THICKNESS AND WIDTH			
	Drawn Wire and Cold Finished Bar		Rolled Bar	
	Thickness	Width	Thickness	Width
Up thru 0.035	.001
0.036-0.064	.0015
0.065-0.500	.002	.002	.006
0.501-0.750	.0025	.0025	.008	.016
0.751-1.000	.0025	.0025	.012	.016
1.001-1.500	.003	.003	.016	.016
1.501-2.000	.005	.005	.016	.031
2.001-3.000	.008	.008	.020	.031
3.001-4.000010	.020	.031
4.001-6.000047
6.001-10.000062

9.6 • DISTANCE ACROSS FLATS SQUARE, HEXAGONAL AND OCTAGONAL WIRE AND BAR

SPECIFIED DISTANCE ACROSS FLATS in.	TOLERANCE in. Plus and Minus		
	ALLOWABLE DEVIATION FROM SPECIFIED DISTANCE ACROSS FLATS		
	Drawn Wire	Cold Finished Bar	Rolled Bar
Up thru 0.035	.001
0.036-0.064	.0015
0.065-0.374	.002
0.375-0.500002
0.501-1.0000025
1.001-1.500003
1.501-2.000005	.016
2.001-3.000008	.020
3.001-4.000020

ALUMINUM(CONT)

PERMISSIBLE VARIATION OF ANSI H35.2(PER ASTM B211)

9. wire, rod and bar—rolled or cold-finished

9.7 • THICKNESS AND WIDTH

FLATTENED WIRE (ROUND EDGE)

SPECIFIED THICKNESS in.	TOLERANCE in. Plus and Minus	SPECIFIED WIDTH in.	TOLERANCE in. Plus and Minus
			ALLOWABLE DEVIATION FROM SPECIFIED THICKNESS
Up thru 0.020 0.021-0.060 0.061-0.187	.001 .0015 .002	Up thru 0.875 0.876-2.000	.007 .010

9.9 • THICKNESS AND WIDTH

ROUGH ROLLED ROUND CORNERED SQUARE AND RECTANGULAR BAR

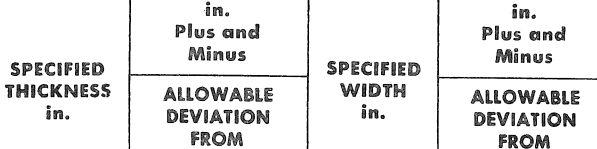
SPECIFIED THICKNESS in.	TOLERANCE in. Plus and Minus	SPECIFIED WIDTH in.	TOLERANCE in. Plus and Minus
			ALLOWABLE DEVIATION FROM SPECIFIED THICKNESS
2.000-8.000	1/16	4.000-16.000	1/4

9.8 • THICKNESS AND WIDTH

FLATTENED AND SLIT WIRE

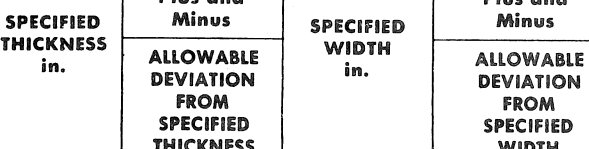
SPECIFIED THICKNESS in.	TOLERANCE in. Plus and Minus	SPECIFIED WIDTH in.	TOLERANCE in. Plus and Minus
			ALLOWABLE DEVIATION FROM SPECIFIED THICKNESS
0.018-0.020 0.021-0.060 0.061-0.080	.001 .0015 .002	0.500-0.625 0.626-1.500 1.501-4.750	.0025 .004 .006

9.10 • LENGTH

SPECIFIC AND MULTIPLE

SPECIFIED DIAMETER WIDTH OR DISTANCE ACROSS FLATS in.	TOLERANCE—in. Plus			
	ALLOWABLE DEVIATION FROM SPECIFIED LENGTH			
	SPECIFIED LENGTH—ft			
	Up thru 12	Over 12 thru 30	Over 30 thru 50	Over 50
Up thru 2.999	1/8	1/4	3/8	1
3.000-7.999	3/16	5/16	7/16	1
8.000 and over	1/4	3/8	1/2	1

9.11 • TWIST

BAR IN STRAIGHT LENGTHS

PRODUCT	TEMPER	SPECIFIED WIDTH (RECTANGLES); SPECIFIED DISTANCE ACROSS FLATS (SQUARE, HEXAGONS AND OCTAGONS) in.	TOLERANCE ^{①③} —DEGREES ALLOWABLE DEVIATION FROM STRAIGHT	
			IN ANY FOOT OR LESS OF LENGTH	IN TOTAL LENGTH OF PIECE ^③
Square, Rectangular and Octagonal Bar	All except 0 and TX51 ^②	Up thru 1.499 1.500-2.999 3.000 and over	1 1/2 1 1/2	1 × length, ft: 7° max 1/2 × length, ft: 5° max 1/4 × length, ft: 3° max
	TX51 ^②	0.500-2.999 3.000 and over	1 1/2 1	1 1/2 × length, ft: 7° max 1/2 × length, ft: 5° max
Hexagonal Bar	All except 0	Up thru 1.499 1.500-2.999 3.000 and over	1 1/2 1 1/2	1 × length, ft: 7° max 1/2 × length, ft: 5° max 1/4 × length, ft: 3° max

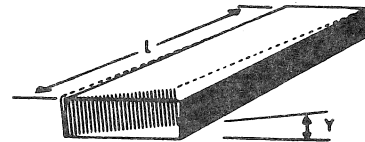

Y (max) in degrees

① For TX51 tempers, tolerance is applicable only to thicknesses of 0.500 in. and over.

② TX51 is a general designation for the following stress-relieved tempers: T351, T451, T651, T851 and T7351.

③ When weight of piece on flat surface minimizes deviation.

ALUMINUM(CONT)

PERMISSIBLE VARIATION OF ANSI H35.2(PER ASTM B211)

9.12 • STRAIGHTNESS ROD AND BAR IN STRAIGHT LENGTHS OTHER THAN SCREW MACHINE STOCK

PRODUCT	TEMPER	SPECIFIED DIAMETER (ROD); SPECIFIED DISTANCE ACROSS FLATS (SQUARES HEXAGONS AND OCTAGONS) SPECIFIED THICKNESS (RECTANGLES) in.	TOLERANCE ^① in.	
			ALLOWABLE DEVIATION (D) FROM STRAIGHT	
			IN ANY FOOT OR LESS OF LENGTH	IN TOTAL LENGTH OF PIECE
ROLLED				
Rod and Hexagonal, Square, Rectangular and Octagonal Bar	All except 0	All	.050	.050 × length, ft
COLD FINISHED				
Rod and Hexagonal Bar	All except 0 and TX51 ^②	All	.025	.025 × length, ft
	TX51 ^②	0.500 and over	.025	.025 × length, ft
Square, Rectangular and Octagonal Bar	All except 0 and TX51 ^②	All	.025	.025 × length, ft
	TX51 ^②	0.500 and over	.050	.050 × length, ft

9.13 • STRAIGHTNESS SCREW MACHINE STOCK

SPECIFIED DIAMETER (ROD); SPECIFIED DISTANCE ACROSS FLATS (HEXAGONAL BAR) in.	TEMPER	TOLERANCE ^① in.	
		Allowable Deviation From Straight	
		In Any Foot or Less of Length	In 12 Feet
All	All except TX51(2)	0.0125	0.100
0.500 in. and over	TX51(2)	0.0125	0.100

9.14 • FLATNESS (Flat Surfaces)

SURFACE WIDTH in.	TOLERANCE in.
	<p>Maximum Allowable Deviation D</p>
Up thru 1	.004
Over 1	.004xW (Inches)
In any 1 in. of width	.004

① When weight of piece on flat surface minimizes deviation.

9.15 • ANGULARITY

Allowable deviation from nominal angle: ± 1 degree.

9.16 • SQUARENESS OF SAW CUTS

Allowable deviation from square: 1 degree.
--

② TX51 is a general designation for the following stress-relieved tempers: T351, T451, T651, T851 and T7351.

ALUMINUM(CONT)

MECHANICAL PROPERTIES & TOLERANCES (PER ASTM B210) (EXTRUDED TUBES)

INDEX TO TABLES OF PERMISSIBLE VARIATION OF ANSI H35.2

ALLOY & TEMPER	WALL THICKNESS	TENSILE STRENGTH KSI* (MIN)	YIELD STRENGTH (.2% OFFSET) KSI" (MIN)	ELONGATION IN 2 IN (%) FULL-SECTION SPECIMEN, MIN
2024 T3	.050-.259	64	42	14
3003 H16	.010-.024	24	21	
6061 T6	.025-.049	42	35	10
	.050-.259	42	35	12
7075 T6	.035-.259	77	66	8

TABLE NO.	TITLE
11.1	Diameter, Round Tube
11.2	Width and Depth, Square, Rectangular, Hexagonal and Octagonal Tube
11.3	Diameter, Oval, Elliptical, and Streamline Tube
11.4	Corner Radii
11.5	Wall Thickness, Round and Other-than-Round Tube
11.6	Straightness
11.7	Twist
11.8	Length
11.9	Flatness, (Flat Surfaces) Other-than-Round Tube
11.10	Squareness of Cut Ends
11.11	Angularity
11.12	Surface Roughness
11.13	Dents

11. drawn tube

11.1 • DIAMETER ROUND TUBE

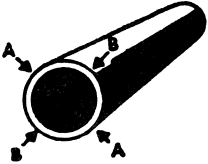
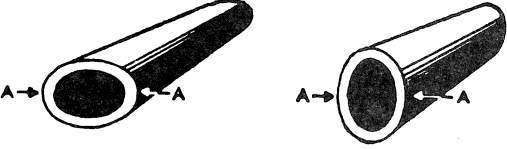
SPECIFIED DIAMETER ^① in.	TOLERANCE ^② —in. Plus and Minus		
	ALLOWABLE DEVIATION OF MEAN DIAMETER ^③ FROM SPECIFIED DIAMETER (Size)  Difference between ½ (AA+BB) and specified diameter	ALLOWABLE DEVIATION OF DIAMETER AT ANY POINT FROM SPECIFIED DIAMETER ^④ (Ovalness)  Difference between AA and specified diameter	
		NON-HEAT-TREATED TUBE ^⑤	HEAT-TREATED TUBE ^⑤
Col. 1	Col. 2	Col. 3	Col. 4
Up thru 0.500	.003	.003	.006
0.501- 1.000	.004	.004	.008
1.001- 2.000	.005	.005	.010
2.001- 3.000	.006	.006	.012
3.001- 5.000	.008	.008	.016
5.001- 6.000	.010	.010	.020
6.001- 8.000	.015	.015	.030
8.001-10.000	.020	.020	.040
10.001-12.000	.025	.025	.050

ALUMINUM(CONT)

PERMISSIBLE VARIATION OF ANSI H35.2 (PER ASTM B210)

11.2 • WIDTH AND DEPTH SQUARE, RECTANGULAR, HEXAGONAL AND OCTAGONAL TUBE

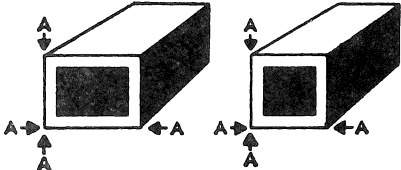
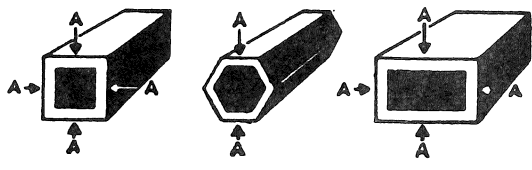
SPECIFIED WIDTH OR DEPTH ^① in.	TOLERANCE ^② —in. Plus and Minus			
	ALLOWABLE DEVIATION OF WIDTH OR DEPTH AT CORNERS FROM SPECIFIED WIDTH OR DEPTH		ALLOWABLE DEVIATION OF WIDTH OR DEPTH NOT AT CORNERS FROM SPECIFIED WIDTH OR DEPTH ^④	
	 Difference between AA and specified width or depth		 Difference between AA and specified width, depth, or distance across flats	
	SQUARE, RECTANGULAR	SQUARE, HEXAGONAL, OCTAGONAL	RECTANGULAR	
Col. 1	Col. 2	Col. 3	Col. 4	
Up thru 0.500	.003	.006	The tolerance for the width is the value in Col. 3 for a dimension equal to the depth, and conversely, but in no case is the tolerance less than at the corners. ^⑥	
0.501- 1.000	.004	.008		
1.001- 2.000	.005	.010		
2.001- 3.000	.006	.012		
3.001- 5.000	.008	.016		
5.001- 6.000	.010	.020		
6.001- 8.000	.015	.030		
8.001-10.000	.020	.040		
10.001-12.000	.025	.050		

① When outside diameter, inside diameter, and wall thickness (or their equivalent dimensions in other-than-round tube) are all specified, standard tolerances are applicable to any two of these dimensions, but not to all three. When both outside and inside diameters are specified, tolerances applicable to the O.D. dimension shall apply to both O.D. and I.D.

② When a dimension tolerance is specified other than as an equal bilateral tolerance, the value of the standard tolerance is that which would apply to the mean of the maximum and minimum dimensions permissible under the tolerance.

③ Mean diameter is the average of two diameter measurements taken at right angles to each other at any point along the length.

④ Not applicable to annealed (O temper) tube, coiled tube, or tube having a wall thickness less than 2½ percent of the specified outside diameter. The tolerance for tube with wall thicknesses less than 2½ percent of the specified outside diameter is determined by multiplying the applicable tolerance in columns 3 and 4 as follows:
 2% to 2½% excl. — 1.5 × tolerance
 1½% to 2% excl. — 2.0 × tolerance
 1% to 1½% excl. — 3.0 × tolerance

⑤ For the T8 tempers of 6063 the tolerances in Column 3 apply.

⑥ Example: The width tolerance of 1x3 inch rectangular tube is plus and minus 0.008 inch and the depth tolerance is plus and minus 0.012 inch.

11.3 • DIAMETER OVAL, ELLIPTICAL AND STREAMLINE TUBE

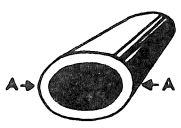
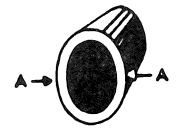
EQUIVALENT ROUND DIAMETER ^⑤ in.	TOLERANCE—in. ①②			
	LENGTH OF MAJOR AXIS, in.		LENGTH OF MINOR AXIS, in.	
	 Difference between AA and specified length		 Difference between AA and specified length	
Up thru 2.500	+.040	-.025	+.025	-.015
2.501- 4.250	+.050	-.035	+.035	-.025
4.251- 6.000	+.070	-.050	+.055	-.040
6.001- 8.000	+.100	-.085	+.080	-.060
8.001-10.000	+.160	-.140	+.115	-.085

11.4 • CORNER RADII

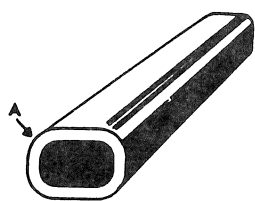
SPECIFIED RADIUS in.	TOLERANCE—in. ②
	ALLOWABLE DEVIATION FROM SPECIFIED RADIUS
	 Difference between radius A and specified radius
Sharp corners Up thru 0.187 0.188 and over	+¼ ±¼ ±10%

ALUMINUM(CONT)

PERMISSIBLE VARIATION OF ANSI H35.2 (PER ASTM B210)

11. drawn tube

11.5 • WALL THICKNESS ROUND AND OTHER-THAN-ROUND TUBE

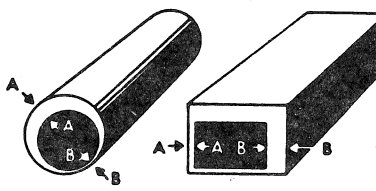
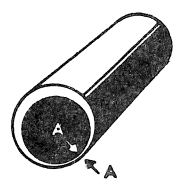
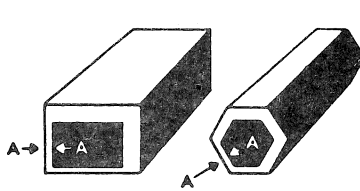
SPECIFIED THICKNESS ^④ in.	TOLERANCE ^{①②} —in. Plus and Minus		
	ALLOWABLE DEVIATION OF MEAN ^③ WALL THICKNESS FROM SPECIFIED WALL THICKNESS	ALLOWABLE DEVIATION OF WALL THICKNESS AT ANY POINT FROM SPECIFIED WALL THICKNESS (Eccentricity)	
		ROUND, NON-HEAT-TREATABLE ALLOYS ^⑥	ROUND, HEAT-TREATABLE ALLOYS AND OTHER THAN ROUND, ALL ALLOYS
	 Difference between $\frac{1}{2}(AA + BB)$ and specified wall thickness	 Difference between AA and specified wall thickness	 Difference between AA and specified wall thickness
Col. 1	Col. 2	Col. 3	Col. 4
0.010-0.035	.002	.002	Plus and minus 10% of specified wall thickness, min ± 0.003
0.036-0.049	.003	.003	
0.050-0.083	.004	.004	
0.084-0.120	.005	.006	
0.121-0.203	.006	.008	
0.204-0.300	.008	.012	
0.301-0.375	.015	.020	
0.376-0.500	.020	.030	

① When outside diameter, inside diameter, and wall thickness (or their equivalent dimensions in other-than-round tube) are all specified, standard tolerances are applicable to any two of these dimensions, but not to all three.

② When a dimension tolerance is specified other than as an equal bilateral tolerance, the value of the standard tolerance is that which would apply to the mean of the maximum and minimum dimensions permissible under the tolerance.

③ The mean wall thickness of round tube is the average of two measurements taken opposite each other. The mean wall thickness of other-than-

round tube is the average of two measurements taken opposite each other at approximate center line of tube and perpendicular to the longitudinal axis of the cross section.

④ When dimensions specified are outside and inside, rather than wall thickness itself, allowable deviation at any point (eccentricity) is plus and minus 10 percent of the mean wall thickness but not less than ± 0.003 inch.

⑤ Equivalent round diameter is the diameter of the circle having a circumference equal to the perimeter of the tube.

⑥ For coiled tube, values in Column 4 apply.

11.6 • STRAIGHTNESS

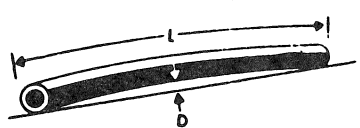
SPECIFIED OUTSIDE DIAMETER OR WIDTH in.	TOLERANCE—in. ^{①②}	
	ALLOWABLE DEVIATION FROM STRAIGHT	
	 D (max)	
	IN ANY FOOT OR LESS OF LENGTH	IN TOTAL LENGTH OF PIECE
Up thru 0.374	.500	$.500^{\text{③}} \times \text{Length, ft}$
0.375-5.999	.010	$.010 \times \text{Length, ft}$
6.000 and over	.020	$.020 \times \text{Length, ft}$

11.7 • TWIST

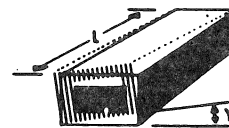
SPECIFIED WIDTH in.	TOLERANCE—Degrees ^③	
	ALLOWABLE DEVIATION FROM STRAIGHT	
	 Y (max) in degrees	
	IN ANY FOOT OR LESS OF LENGTH	IN TOTAL LENGTH OF PIECE
Up thru 1.499	1	$1 \times \text{Length, ft: } 7^\circ \text{ max}$
1.500-2.999	$\frac{1}{2}$	$\frac{1}{2} \times \text{Length, ft: } 5^\circ \text{ max}$
3.000 and over	$\frac{1}{4}$	$\frac{1}{4} \times \text{Length, ft: } 3^\circ \text{ max}$

ALUMINUM(CONT)

MECHANICAL PROPERTIES & TOLERANCES (PER ASTM B221)

11.8 • LENGTH

SPECIFIED OUTSIDE DIAMETER OR WIDTH in.	TOLERANCE—in. Plus except as noted							
	ALLOWABLE DEVIATION FROM SPECIFIED LENGTH							
	STRAIGHT				COILED			
	SPECIFIED LENGTH—ft							
	Up thru 12	Over 12 thru 30	Over 30 thru 50	Over 50	Up thru 100	Over 100 to 250	250 to 500	500 and over
Up thru 0.249	1/4	3/8	1/2	1	+5%, -0%	±10%	±15%	±20%
0.250-1.249	1/8	1/4	3/8	1	+5%, -0%	±10%	±15%	±20%
1.250-2.999	1/8	1/4	3/8	1
3.000-7.999	3/16	7/16	7/16	1
8.000 and over	1/4	3/8	1/2	1

11.9 • FLATNESS (Flat Surfaces) OTHER-THAN-ROUND TUBE

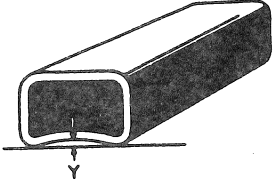
SPECIFIED WIDTH OR DEPTH in.	TOLERANCES ^① —in.
	ALLOWABLE DEVIATION FROM FLAT
	 <p>Maximum allowable distance Y</p>
Up thru 0.500	.003
0.501- 1.000	.004
1.001- 2.000	.005
2.001- 3.000	.006
3.001- 5.000	.008
5.001- 6.000	.010
6.001- 8.000	.015
8.001-10.000	.020
10.001-12.000	.025

11.10 • SQUARENESS OF CUT ENDS

Allowable deviation from square: 1 degree.

11.11 • ANGULARITY

Allowable deviation from specified angle: ±2 degrees.

^① Tolerance is applicable when weight of tube on flat surface minimizes deviation.

^② Not applicable to annealed (0 temper) tube.

^③ Not applicable to length under 10 feet.

^④ Not applicable to annealed (0 temper) tube, coiled tube, or tube having a wall thickness less than 0.020 inch or less than 2½% of the equivalent round diameter. Equivalent round diameter is the diameter of a circle having a circumference equal to the perimeter of the tube.

11.12 • SURFACE ROUGHNESS DRAWN TUBE^①

Depth of surface imperfections shall not exceed 10% of the specified (or nominal) wall thickness or 0.005 inch, whichever is smaller.

^① Not applicable to annealed (0 temper) tube.

11.13 • DENTS DRAWN TUBE

Depth of dents shall not exceed twice the applicable ovality tolerance (Table 11.1) for the particular tube size being measured, except for tube having a wall thickness less than 2½ percent of the Outside Diameter in which case the following multipliers apply:

2%	to 2½% exclusive	- 2.5 x tolerance (max.)
1½%	to 2% exclusive	- 3.0 x tolerance (max.)
1%	to 1½% exclusive	- 4.0 x tolerance (max.)

ALUMINUM(CONT)

MECHANICAL PROPERTIES & TOLERANCES (PER ASTM B221)

ALLOY & TEMPER	SPECIFIED SECTION OF WALL THICKNESS, IN.	TENSILE STRENGTH KSI* (MIN)	YIELD STRENGTH (.2 % OFFSET) KSI* (MIN)	ELONGATION IN 2 IN. OR 4 x DIA MIN %
2024 T4 T3510 T3511	up thru .249	57	42	12
	.250-.749	60	44	12
	.750-1.499	65	46	10
	1.500 and over	70	52	10
		68	48	8
6061 T6, T62 T6510 T6511	up thru .249	38	35	8
	.250 and over	38	35	10
6063 T4, T42	up thru .500	19	10	14
	.501-1.000	18	9	14
T5	up thru .500	22	16	8
	.501-1.000	21	15	8
T52	up thru 1.000	22	16	8
T6	up thru .124	33	25	8
	.125-1.000	30	25	10

Index to Table of Permissible Variations of ANSI H35.2

TABLE NO.	TITLE
12.1	Diameter Round Tube Except for T3510, T4510, T6510, T73510, T76510 and T8510 Tempers
12.2	Width and Depth: Square, Rectangular, Hexagonal, Octagonal Tube Except for T3510, T4510, T6510, T73510, T76510 and T8510 Tempers
12.3	Wall Thickness: Round Tube
12.4	Wall Thickness: Other Than Round Tube
12.5	Length Extruded Tube
12.6	Twist: Other Than Round Tube
12.7	Straightness: Tube in Straight Lengths
12.8	Flatness: Flat Surfaces
12.9	Squareness of Cut Ends: Extruded Tube
12.10	Corner and Fillet Radii: Tube Other Than Round
12.11	Angularity: Tube Other Than Round
12.12	Surface Roughness: Extruded Tube
12.13	Dents: Extruded Tube

12. extruded tube

12.1 • DIAMETER

ROUND TUBE EXCEPT FOR T3510, T4510, T6510, T73510, T76510 AND T8510 TEMPERS^⑦

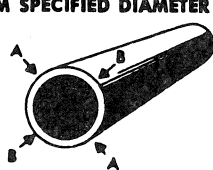
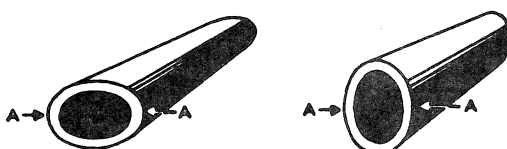
SPECIFIED DIAMETER ^① in.	TOLERANCE ^② —in. Plus and Minus			
	ALLOWABLE DEVIATION OF MEAN DIAMETER ^③ FROM SPECIFIED DIAMETER (Size)		ALLOWABLE DEVIATION OF DIAMETER AT ANY POINT FROM SPECIFIED DIAMETER ^④ (Ovalness)	
	 Difference between 1/2 (AA+BB) and specified diameter		 Difference between AA and specified diameter	
	Alloys 5083, 5086, 5456	Other Alloys	Alloys 5083, 5086, 5456	Other Alloys
0.500- 0.999	.015	.010	.030	.020
1.000- 1.999	.018	.012	.038	.025
2.000- 3.999	.023	.015	.045	.030
4.000- 5.999	.038	.025	.075	.050
6.000- 7.999	.053	.035	.113	.075
8.000- 9.999	.068	.045	.150	.100
10.000-11.999	.083	.055	.188	.125
12.000-13.999	.098	.065	.225	.150
14.000-15.999	.113	.075	.263	.175
16.000-17.999	.128	.085	.300	.200

Footnotes are on page 7-21.



ALUMINUM(CONT)

PERMISSIBLE VARIATION OF ANSI H35.2 (PER ASTM B221)

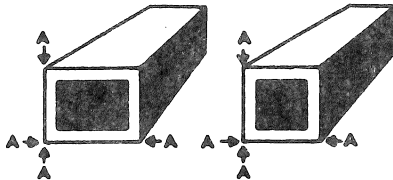
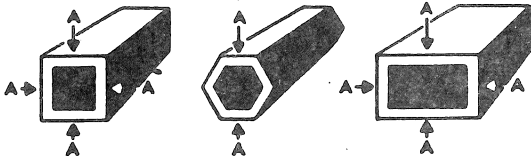
12.2 • WIDTH AND DEPTH SQUARE, RECTANGULAR, HEXAGONAL, OCTAGONAL TUBE EXCEPT FOR T3510, T4510 T6510, T73510, T76510 and T8510 TEMPER ⑦

SPECIFIED WIDTH OR DEPTH ① in.	TOLERANCE ②—in. Plus and Minus				
	ALLOWABLE DEVIATION OF WIDTH OR DEPTH AT CORNERS FROM SPECIFIED WIDTH OR DEPTH		ALLOWABLE DEVIATION OF WIDTH OR DEPTH NOT AT CORNERS FROM SPECIFIED WIDTH OR DEPTH ④		
	 Difference between AA and specified width or depth		 Difference between AA and specified width, depth, or distance across flats		
SQUARE, RECTANGULAR		SQUARE, HEXAGONAL, OCTAGONAL	RECTANGULAR		
	Alloys 5083, 5086, 5456	Other Alloys	Alloys 5083, 5086, 5456	Other Alloys	All Alloys
0.500- 0.749	.018	.012	.030	.020	The tolerance for the width is the value in the previous column for a dimension equal to the depth, and conversely, but in no case is the tolerance less than at the corners. Example: The width tolerance of a 1x3 inch alloy 6061 rectangular tube is ±0.025 inch and the depth tolerance ±0.035 inch.
0.750- 0.999	.021	.014	.030	.020	
1.000- 1.999	.027	.018	.038	.025	
2.000- 3.999	.038	.025	.053	.035	
4.000- 4.999	.053	.035	.068	.045	
5.000- 5.999	.068	.045	.083	.055	
6.000- 6.999	.083	.055	.098	.065	
7.000- 7.999	.098	.065	.108	.075	
8.000- 8.999	.113	.075	.123	.085	
9.000- 9.999	.128	.085	.143	.095	
10.000-10.999	.143	.095	.158	.105	
11.000-12.999	.158	.105	.173	.115	

12.3 • WALL THICKNESS ROUND TUBE

SPECIFIED WALL THICKNESS ⑥ in.	TOLERANCE ① ②—in. Plus and Minus								ALLOWABLE DEVIATION OF WALL THICKNESS AT ANY POINT FROM MEAN WALL THICKNESS ⑤ (Eccentricity)  Difference between AA and mean wall thickness
	ALLOWABLE DEVIATION OF MEAN WALL THICKNESS ③ FROM SPECIFIED WALL THICKNESS  Difference between 1/2 (AA + BB) and specified wall thickness								
	OUTSIDE DIAMETER—in.								
	Under 1.250		1.250-2.999		3.000-4.999		5.000 and over		
	Alloys 5083, 5086, 5456	Other Alloys	Alloys 5083, 5086, 5456	Other Alloys	Alloys 5083, 5086, 5456	Other Alloys	Alloys 5083, 5086, 5456	Other Alloys	All Alloys
Under 0.047	.009	.006	Plus and minus 10% of mean wall thickness max ±0.060 min ±0.010
0.047-0.061	.011	.007	.012	.008	.012	.008	.015	.010	
0.062-0.077	.012	.008	.012	.008	.014	.009	.018	.012	
0.078-0.124	.014	.009	.014	.009	.015	.010	.023	.015	
0.125-0.249	.014	.009	.014	.009	.020	.013	.030	.020	
0.250-0.374	.017	.011	.017	.011	.024	.016	.038	.025	
0.375-0.499023	.015	.032	.021	.053	.035	max ±0.060 min ±0.010
0.500-0.749030	.020	.042	.028	.068	.045	
0.750-0.999053	.035	.083	.055	
1.000-1.499068	.045	.098	.065	
1.500-2.000113	.075	
2.001-2.499128	.085	
2.500-2.999143	.095	±0.120
3.000-3.499158	.105	
3.500-4.000173	.115	
.....	

FOOTNOTES ARE ON PAGE 7-21.

ALUMINUM(CONT)

PERMISSIBLE VARIATION OF ANSI H35.2 (PER ASTM B221)

12.4 • WALL THICKNESS OTHER-THAN-ROUND TUBE

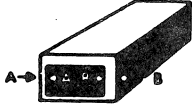
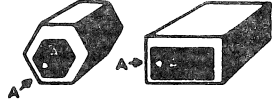
SPECIFIED WALL THICKNESS ^⑥ in.	TOLERANCE ^{① ②} —in. Plus and Minus							
	ALLOWABLE DEVIATION OF MEAN ^⑤ WALL THICKNESS FROM SPECIFIED WALL THICKNESS			ALLOWABLE DEVIATION OF WALL THICKNESS AT ANY POINT FROM MEAN WALL THICKNESS ^⑤ (Eccentricity)				
								
	CIRCUMSCRIBING CIRCLE DIAMETER ^⑩ —in.							
	Under 5.000		5.000 and over		Under 5.000		5.000 and over	
	Alloys 5083, 5086, 5456	Other Alloys	Alloys 5083, 5086, 5456	Other Alloys	All Alloys	All Alloys		
Under 0.047	.008	.005	.012	.008	.005	Plus and minus 10% of mean wall thickness max ±0.060 min ±0.010		
0.047-0.061	.009	.006	.014	.009	.007			
0.062-0.124	.011	.007	.015	.010	.010			
0.125-0.249	.012	.008	.023	.015	.015			
0.250-0.374	.017	.011	.030	.020	.025			
0.375-0.499	.021	.014	.045	.030	.030			
0.500-0.749	.038	.025	.060	.040	.040			
0.750-0.999	.053	.035	.075	.050	.050			
1.000-1.499	.068	.045	.090	.060	.060			
1.500-2.000105	.070	.060			

12.5 • LENGTH

SPECIFIED OUTSIDE DIAMETER OR WIDTH in.	TOLERANCE—in. Plus except as noted								
	ALLOWABLE DEVIATION FROM SPECIFIED LENGTH								
	STRAIGHT					COILED			
	SPECIFIED LENGTH—ft								
	Up thru 12	Over 12 thru 30	Over 30 thru 50	Over 50	Up thru 100	Over 100 to 250	250 to 500	500 and over	
0.500-1.249	1/8	1/4	3/8	1	+5%, -0%	±10%	±15%	±20%	
1.250-2.999	1/8	1/4	3/8	1	
3.000-7.999	3/16	1/4	7/16	1	
8.000 and over	1/4	3/8	1/2	1	

12.6 • TWIST ^⑩ OTHER-THAN-ROUND TUBE

TEMPER	SPECIFIED WIDTH in.	SPECIFIED THICKNESS in.	TOLERANCE ^⑨ —Degrees	
			ALLOWABLE DEVIATION FROM STRAIGHT	
			IN ANY FOOT OR LESS OF LENGTH	IN TOTAL LENGTH OF PIECE
All except 0, TX510, TX511 ^⑧	0.500 thru 1.499 1.500-2.999 3.000 and over	All All All	1 1/2 1/4	1 × length, ft: 7° max 1/2 × length, ft: 5° max 1/4 × length, ft: 3° max
TX510 ^⑧	0.500 and over	0.095 and over	⑦	⑦
TX511 ^⑧	0.500-1.499 1.500-2.999 3.000 and over	0.095 and over 0.095 and over 0.095 and over	1 1/2 1/4	1 × length, ft: 7° max 1/2 × length, ft: 5° max 1/4 × length, ft: 3° max

ALUMINUM(CONT)

PERMISSIBLE VARIATION OF ANSI H35.2 (PER ASTM B221)

12.7 ● STRAIGHTNESS

TUBE IN STRAIGHT LENGTHS

TEMPER	SPECIFIED OUTSIDE DIAMETER OR WIDTH in.	TOLERANCE ^① —in.	
		ALLOWABLE DEVIATION (D) FROM STRAIGHT	
		IN ANY FOOT OR LESS OF LENGTH	IN TOTAL LENGTH OF PIECE
All except 0, TX510 ^③	0.500-5.999 ^⑫ 6.000 and over	.010 .020	.010 × length, ft .020 × length, ft
TX510 ^③	0.500 and over ^⑫	⑦	⑦

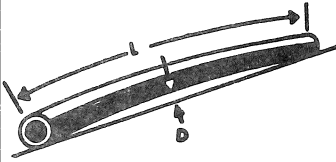

12.8 ● FLATNESS (Flat Surfaces)

EXCEPT FOR 0, T3510, T4510, T6510, T73510, T76510 AND T8510 TEMPER^⑦

MINIMUM THICKNESS OF METAL FORMING THE SURFACE in.	TOLERANCE—in.	
	Maximum Allowable Deviation Y	
	WIDTHS UP THRU 1 IN. OR ANY 1 IN. INCREMENT OF WIDER SURFACES	WIDTHS OVER 1 IN.
Up thru 0.187 0.188 and over	0.006 0.004	0.006xW (in.) 0.004xW (in.)

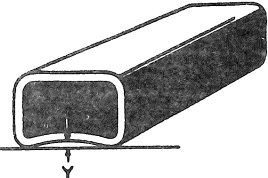

12.9 ● SQUARENESS OF CUT ENDS

Allowable deviation from square: 1 degree.

FOOTNOTES FOR PAGES 7-18 THRU 7-21.

① When outside diameter, inside diameter, and wall thickness (or their equivalent dimensions in other-than-round tube) are all specified, standard tolerances are applicable to any two of these dimensions, but not to all three. When both outside and inside diameters are specified, tolerances applicable to the O.D. dimension shall apply to both O.D. and I.D.

② When a dimension tolerance is specified other than as an equal bilateral tolerance, the value of the standard tolerance is that which would apply to the mean of the maximum and minimum dimensions permissible under the tolerance.

③ Mean diameter is the average of two diameter measurements taken at right angles to each other at any point along the length.

④ Not applicable in the annealed (O) temper or if wall thickness is less than 2½ percent of the outside diameter or equivalent round diameter. The equivalent round diameter is the diameter of a circle having a circumference equal to the perimeter of the tube.

⑤ The mean wall thickness of round tube is the average of two measurements taken opposite each other. The mean wall thickness of other-than-round tube is the average of two measurements taken opposite each other at approximate center line of tube and perpendicular to the longitudinal axis of the cross section.

⑥ When dimensions specified are outside and inside, rather than wall thickness itself, allowable deviation at any point (eccentricity) applies to mean wall thickness.

12.10 ● CORNER AND FILLET RADII

SPECIFIED RADIUS in.	TOLERANCE—in.
	ALLOWABLE DEVIATION FROM SPECIFIED RADIUS
Sharp corners Up thru 0.187 0.188 and over	+¼ ±¼ ±10%

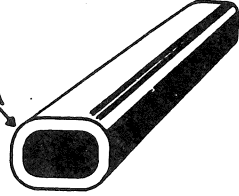

12.11 ● ANGULARITY

Allowable deviation from specified angle: ± 2 degrees

12.12 ● SURFACE ROUGHNESS

EXTRUDED TUBE^⑭

SPECIFIED WALL THICKNESS in.	ALLOWABLE DEPTH OF DEFECTS in. Max.
Up thru 0.063	0.0025
0.064—0.125	0.003
0.126—0.188	0.0035
0.189—0.250	0.004
0.251—0.500	0.005
0.501 and over	0.008

12.13 ● DENTS EXTRUDED TUBE^⑮

Depth of dents shall not exceed twice the applicable ovality tolerance (Table 12.1) for the particular tube size being measured, except for tube having a wall thickness less than 2½ percent of the Outside Diameter in which case the following multipliers apply:

2% to 2½% exclusive — 2.5 x tolerance (max.)
1½% to 2% exclusive — 3.0 x tolerance (max.)
1% to 1½% exclusive — 4.0 x tolerance (max.)

⑦ Tolerances for T3510, T4510, T6510, T73510, T76510 and T8510 tempers shall be as agreed upon between purchaser and vendor at the time the contract or order is entered.

⑧ TX510 and TX511 are general designations for the following stress-relieved tempers: T3510, T4510, T6510, T8510, T73510, T76510, and T3511, T4511, T6511, T8511, T73511, T76511 respectively.

⑨ When weight of piece on flat surface minimizes deviation.

⑩ The circumscribing circle diameter is the diameter of the smallest circle that will completely enclose the cross section of the extruded product.

⑪ Twist is normally measured by placing the extruded section on a flat surface and measuring the maximum distance at any point along its length between the bottom surface of the section and the flat surface. From this measurement, the deviation from true straightness of the section is subtracted. The remainder is the twist. To convert the standard twist tolerance (degrees) to an equivalent linear value, the tangent of the standard tolerance is multiplied by the width of the surface of the section that is on the flat surface.

⑫ Not applicable to TX510 or TX511 temper tube having a wall thickness less than 0.095 in.

⑬ Defects include die lines, mandrel lines and handling marks.

⑭ Not applicable to tubes over 12.750 O.D.

⑮ Not applicable to annealed (O temper) tube.

ALUMINUM(CONT)

MECHANICAL PROPERTIES & TOLERANCES (PER ASTM B209)

ALLOY	TEMPER	THICKNESS, IN.	TENSILE STRENGTH (PSI)	YIELD STRENGTH (.2% OFFSET) (PSI)	ELONGATION %
2024	H3	.008-.009	63,000 min	42,000 min	10
		.010-.020	63,000 min	42,000 min	12
		.021-.249	64,000 min	42,000 min	15
3003	H14	.009-.012	20,000-26,000	17,000 min	1
		.013-.019	20,000-26,000	17,000 min	2
		.020-.031	20,000-26,000	17,000 min	3
		.032-.050	20,000-26,000	17,000 min	4
		.051-.113	20,000-26,000	17,000 min	5
		.114-.161	20,000-26,000	17,000 min	6
		.162-.249	20,000-26,000	17,000 min	7
		.250-.499	20,000-26,000	17,000 min	8
5005	0	.006-.007	15,000-21,000	5,000 min	12
		.008-.012	15,000-21,000	5,000 min	14
		.013-.019	15,000-21,000	5,000 min	16
		.020-.031	15,000-21,000	5,000 min	18
		.032-.050	15,000-21,000	5,000 min	20
		.051-.113	15,000-21,000	5,000 min	21
		.114-.249	15,000-21,000	5,000 min	22
		.250-3.00	15,000-21,000	5,000 min	22
5005	H14	.009-.031	21,000-27,000	17,000 min	1
		.032-.050	21,000-27,000	17,000 min	2
		.051-.113	21,000-27,000	17,000 min	3
		.114-.161	21,000-27,000	17,000 min	5
		.162-.249	21,000-27,000	17,000 min	6
		.250-.499	21,000-27,000	17,000 min	8
		.500-1.00	21,000-27,000	17,000 min	10
		5005	H32	.017-.019	17,000-23,000
.020-.031	17,000-23,000			12,000 min	4
.032-.050	17,000-23,000			12,000 min	5
.051-.113	17,000-23,000			12,000 min	7
.114-.161	17,000-23,000			12,000 min	8
.162-.249	17,000-23,000			12,000 min	9
.250-2.00	17,000-23,000			12,000 min	10
5005	H34			.009-.012	20,000-26,000
		.013-.031	20,000-26,000	15,000 min	3
		.032-.050	20,000-26,000	15,000 min	4
		.051-.113	20,000-26,000	15,000 min	5
		.114-.161	20,000-26,000	15,000 min	6
		.162-.249	20,000-26,000	15,000 min	7
		.250-.499	20,000-26,000	15,000 min	8
		5005	H134*	.017-.019	18,000-24,000
.020-.031	18,000-24,000			14,000 min	3
.032-.050	18,000-24,000			14,000 min	4
.051-.113	18,000-24,000			14,000 min	6
.114-.161	18,000-24,000			14,000 min	7
.162-.249	18,000-24,000			14,000 min	8
.250-.499	18,000-24,000			14,000 min	9
5052	H32			.017-.019	31,000-38,000
		.020-.050	31,000-38,000	23,000 min	5
		.051-.113	31,000-38,000	23,000 min	7
		.114-.249	31,000-38,000	23,000 min	9
		.250-.499	31,000-38,000	23,000 min	11
5052	H34	.009-.019	34,000-41,000	26,000 min	3
		.020-.050	34,000-41,000	26,000 min	4
		.051-.113	34,000-41,000	26,000 min	6
		.114-.249	34,000-41,000	26,000 min	7
		.250-1.00	34,000-41,000	26,000 min	10
5657	H25	.030-.090	20,000-28,000	--	8
6061	T6	.006-.007	42,000 min	35,000 min	4
		.008-.009	42,000 min	35,000 min	6
		.010-.020	42,000 min	35,000 min	8
		.021-.249	42,000 min	35,000 min	10
7075	T6	.008-.011	74,000 min	63,000 min	5
		.012-.039	76,000 min	67,000 min	7
		.040-.125	78,000 min	68,000 min	8
		.126-.249	78,000 min	69,000 min	8

INDEX TO TABLES OF PERMISSIBLE VARIATIONS OF ANSI H35.2

TABLE NO.	TITLE
3.1	Thickness
3.2	Thickness
3.3	Width, Sheared Flat Sheet and Plate
3.4	Width and Length, Sawed Flat Sheet and Plate
3.5	Length, Sheared Flat Sheet and Plate
3.6	Width, Slit Coiled Sheet
3.7	Lateral Bow, Coiled Sheet
3.8	Lateral Bow, Flat Sheet and Plate
3.9	Squareness, Flat Sheet and Plate
3.10	Diameter, Sheared or Blanked Sheet & Plate Circles
3.11	Diameter, Sawed Sheet & Plate Circles
3.12	Flatness, Flat Sheet
3.13	Flatness, Sawed or Sheared Plate

* 5005 H134 is made from 5005 H12. The mechanical properties given are for 5005 H12. Cold-working to produce patterns will alter the properties to some degree.

The full text of this ASTM is available for review at 78-567, or for more information, call Norma, Ext. 2577.

ALUMINUM(CONT)

RECOMMENDED MINIMUM BEND RADII FOR 90° COLD FORMING OF SHEET AND PLATE

ALLOY	TEMPER	RADII FOR VARIOUS THICKNESSES EXPRESSED IN TERMS OF THICKNESS "t"							
		1/64 IN.	1/32 IN.	1/16 IN.	1/8 IN.	3/16 IN.	1/4 IN.	3/8 IN.	1/2 IN.
2024	T4	2-1/2 t	3 t	4 t	5 t	5 t	6 t	7 t	7-1/2 t
3003	H14	9	9	9	1 t	1 t	1-1/2 t	2 t	2-1/2 t
5005	O	0	0	0	0	1/2 t	1 t	1 t	1-1/2 t
5005	H14	0	0	0	1 t	1-1/2 t	1-1/2 t	2 t	2-1/2 t
5005	H32	0	0	0	1/2 t	1 t	1 t	1-1/2 t	2 t
5005	H34	0	0	0	1 t	1-1/2 t	1-1/2 t	2 t	2-1/2 t
5052	H32	0	0	1 t	1-1/2 t	1-1/2 t	1-1/2 t	1-1/2 t	2 t
5052	H34	0	1 t	1-1/2 t	2 t	2 t	2-1/2 t	2-1/2 t	3 t
5657	H25	0	0	0	1 t				
6061	T6	1 t	1 t	1-1/2 t	2-1/2 t	3 t	3-1/2 t	4-1/2 t	5 t
7075	T6	3 t	4 t	5 t	6 t	6 t	8 t	9 t	9-1/2 t

1. The radii listed are the minimum recommended for bending sheets and plates without fracturing in a standard press brake with air bend dies. Other types of bending operations may require larger radii or permit smaller radii. The minimum permissible radii will also vary with the design and condition of the tooling.
2. Alclad sheet in the heat-treatable alloys can be bent over slightly smaller radii than the corresponding tempers of the bare alloy.
3. Heat-treatable alloys can be formed over appreciably smaller radii immediately after solution heat treatment.
4. The H112 temper (applicable to non-heat treatable alloys) is supplied in the as-fabricated condition without special property control but usually can be formed over radii applicable to the H14 (or H34) temper or smaller.

ALUMINUM(CONT)

PERMISSIBLE VARIATION OF ANSI H35.2 (PER ASTM B209)

3. sheet and plate

3.1 • THICKNESS^①

ALLOYS 2014, 2024, 2124, 2219, 3004, 5052, 5083, 5086, 5154, 5252, 5254, 5454, 5456, 5652, 6061, 7039, 7075, 7079, 7178, AND BRAZING SHEET NOS. 11, 12, 21, 22, 23 AND 24.

NOTE: ALSO APPLICABLE TO THE ALLOYS LISTED WHEN SUPPLIED AS ALCLAD.

SPECIFIED THICKNESS in.	SPECIFIED WIDTH—in.														
	Up thru 18	Over 18 thru 36	Over 36 thru 48	Over 48 thru 54	Over 54 thru 60	Over 60 thru 66	Over 66 thru 72	Over 72 thru 78	Over 78 thru 84	Over 84 thru 90	Over 90 thru 96	Over 96 thru 132	Over 132 thru 144	Over 144 thru 156	Over 156 thru 168
	TOLERANCE—in. Plus and Minus														
0.006-0.010	.001	.0015	.0025	.0025
0.011-0.017	.0015	.0015	.0025	.0035
0.018-0.028	.0015	.002	.0025	.0035	.004	.004	.004
0.029-0.036	.002	.002	.0025	.004	.005	.005	.005	.006	.006	.007	.009
0.037-0.045	.002	.0025	.003	.004	.005	.005	.005	.006	.006	.007	.011
0.046-0.068	.0025	.003	.004	.005	.006	.006	.006	.007	.007	.008	.012	.013
0.069-0.076	.003	.003	.004	.005	.006	.006	.006	.007	.007	.012	.012	.016
0.077-0.096	.0035	.0035	.004	.005	.006	.006	.006	.007	.007	.012	.012	.016
0.097-0.108	.004	.004	.005	.005	.007	.007	.007	.008	.008	.016	.018	.020
0.109-0.125	.0045	.0045	.005	.005	.007	.007	.007	.008	.008	.016	.018	.020
0.126-0.140	.0045	.0045	.005	.005	.007	.010	.012	.013	.014	.016	.018	.020
0.141-0.172	.006	.006	.008	.008	.009	.012	.014	.015	.016	.017	.019	.023
0.173-0.203	.007	.007	.010	.010	.011	.014	.016	.017	.017	.017	.022	.026
0.204-0.249	.009	.009	.011	.011	.013	.016	.018	.018	.018	.018	.024	.028
0.250-0.320	.013	.013	.013	.013	.015	.018	.020	.020	.020	.020	.025	.030	.035	.042	.053
0.321-0.438	.019	.019	.019	.019	.020	.020	.023	.023	.025	.025	.026	.033	.038	.045	.057
0.439-0.625	.025	.025	.025	.025	.025	.025	.025	.030	.030	.030	.035	.035	.043	.049	.067
0.626-0.875	.030	.030	.030	.030	.030	.030	.030	.037	.037	.037	.045	.045	.054	.059	.077
0.876-1.125	.035	.035	.035	.035	.035	.035	.035	.045	.045	.045	.055	.055	.065	.070	.088
1.126-1.375	.040	.040	.040	.040	.040	.040	.040	.052	.052	.052	.065	.065	.075	.080	.098
1.376-1.625	.045	.045	.045	.045	.045	.045	.045	.060	.060	.060	.075	.075	.085	.090	.108
1.626-1.875	.052	.052	.052	.052	.052	.052	.052	.070	.070	.070	.088	.088
1.876-2.250	.060	.060	.060	.060	.060	.060	.060	.080	.080	.080	.100	.100
2.251-2.750	.075	.075	.075	.075	.075	.075	.075	.100	.100	.100	.125	.125
2.751-3.000	.090	.090	.090	.090	.090	.090	.090	.120	.120	.120	.150	.150
3.001-4.000	.110	.110	.110	.110	.110	.110	.110	.140	.140	.140	.160	.160
4.001-5.000	.125	.125	.125	.125	.125	.125	.125	.150	.150	.150	.160
5.001-6.000	.135	.135	.135	.135	.135	.135	.135	.160	.160	.160	.170

3.3 • WIDTH^① SHEARED FLAT SHEET AND PLATE

SPECIFIED THICKNESS in.	SPECIFIED WIDTH—in.					
	Up thru 6	Over 6 thru 24	Over 24 thru 60	Over 60 thru 96	Over 96 thru 132	Over 132 thru 168
	TOLERANCE—in.					
0.006-0.124	± 1/16	± 3/32	± 1/8	± 1/8	± 5/32	—
0.125-0.249	± 3/32	± 3/32	± 1/8	± 5/32	± 3/16	—
0.250-0.499	+ 1/4	+ 5/16	+ 3/8	+ 3/8	+ 7/16	+ 1/2

3.4 • WIDTH AND LENGTH^① SAWED FLAT SHEET AND PLATE

SPECIFIED THICKNESS in.	SPECIFIED WIDTH AND LENGTH—in.							
	Up thru 30	Over 30 thru 60	Over 60 thru 120	Over 120 thru 240	Over 240 thru 360	Over 360 thru 480	Over 480 thru 600	Over 600 thru 720
	TOLERANCE ^② —in.							
0.080-0.249	± 1/8	± 1/8	± 3/16	± 1/4	± 1/4	± 5/16	± 3/8	± 7/16
0.250-6.000	+ 1/4	+ 5/16	+ 3/8	+ 1/2	+ 9/16	+ 5/8	+ 3/4	+ 7/8

ALUMINUM(CONT)

PERMISSIBLE VARIATION OF ANSI H35.2 (PER ASTM B209)

3.2 • THICKNESS ^① ALLOYS EC, 1060, 1100, 3003, 3005, 3105, 5005, 5050, 5357, 5457, 5657, 1100 REFLECTOR SHEET, CLAD 1100 REFLECTOR SHEET AND CLAD 3003 REFLECTOR SHEET.

NOTE: ALSO APPLICABLE TO THE ALLOYS LISTED WHEN SUPPLIED AS ALCLAD.

SPECIFIED THICKNESS in.	SPECIFIED WIDTH—in.									
	Up thru 18	Over 18 thru 36	Over 36 thru 54	Over 54 thru 72	Over 72 thru 90	Over 90 thru 102	Over 102 thru 132	Over 132 thru 144	Over 144 thru 156	Over 156 thru 168
	TOLERANCE—in. Plus and Minus									
0.006-0.007	.001	.001	.002
0.008-0.010	.001	.0015	.002
0.011-0.017	.0015	.0015	.002
0.018-0.028	.0015	.002	.0025	.003	.004
0.029-0.036	.002	.002	.0025	.0035	.005	.006
0.037-0.045	.002	.0025	.003	.004	.005	.006
0.046-0.068	.0025	.003	.004	.005	.006	.007	.008
0.069-0.076	.0025	.003	.004	.006	.008	.008	.009
0.077-0.096	.003	.003	.004	.006	.008	.009	.010
0.097-0.108	.0035	.004	.005	.007	.009	.010	.012
0.109-0.140	.0045	.0045	.005	.007	.009	.010	.012
0.141-0.172	.006	.006	.008	.009	.011	.012	.015
0.173-0.203	.007	.007	.009	.011	.013	.015	.017
0.204-0.249	.009	.009	.011	.013	.015	.017	.020
0.250-0.320	.013	.013	.013	.015	.017	.020	.023	.032	.040	.050
0.321-0.438	.019	.019	.019	.019	.023	.026	.026	.035	.043	.052
0.439-0.625	.025	.025	.025	.025	.030	.035	.035	.040	.046	.055
0.626-0.875	.030	.030	.030	.030	.037	.045	.045	.050	.056	.064
0.876-1.125	.035	.035	.035	.035	.045	.055	.055	.060	.066	.074
1.126-1.375	.040	.040	.040	.040	.052	.065	.065	.070	.075	.082
1.376-1.625	.045	.045	.045	.045	.060	.075	.075	.080	.085	.092
1.626-1.875	.052	.052	.052	.052	.070	.088	.088
1.876-2.250	.060	.060	.060	.060	.080	.100	.100
2.251-2.750	.075	.075	.075	.075	.100	.125	.125
2.751-3.000	.090	.090	.090	.090	.120	.150	.150
3.001-4.000	.110	.110	.110	.110	.140	.160	.160
4.001-5.000	.125	.125	.125	.125	.150	.160
5.001-6.000	.135	.135	.135	.135	.160	.170

3.5 • LENGTH ^① SHEARED FLAT SHEET AND PLATE

SPECIFIED THICKNESS in.	SPECIFIED LENGTH—in.							
	Up thru 30	Over 30 thru 60	Over 60 thru 120	Over 120 thru 240	Over 240 thru 360	Over 360 thru 480	Over 480 thru 600	Over 600 thru 720
	TOLERANCES ^② —in.							
0.006-0.124	± 1/16	± 3/32	± 1/8	± 5/32	± 3/16	± 7/32	± 9/32	—
0.125-0.249	± 3/32	± 3/32	± 1/8	± 5/32	± 3/16	± 7/32	± 9/32	—
0.250-0.499	+ 1/4	+ 3/8	+ 7/16	+ 1/2	+ 9/16	+ 5/8	+ 11/16	+ 3/4

3.6 • WIDTH ^① SLIT COILED SHEET

SPECIFIED THICKNESS in.	SPECIFIED WIDTH—in.					
	Up thru 6	Over 6 thru 12	Over 12 thru 24	Over 24 thru 48	Over 48 thru 60	Over 60 thru 96
	TOLERANCE—in. Plus and Minus					
0.006-0.125	0.010	0.016	1/32	3/64	1/16	1/8
0.126-0.186	0.012	0.020	1/32	1/16	3/32
0.187-0.249	0.016	0.025	3/64	3/32	1/8

^①When a dimension tolerance is specified other than as an equal bilateral tolerance, the value of the standard tolerance is that which would apply to the mean of the maximum and minimum dimensions permissible under the tolerance.

3.7 • LATERAL BOW COILED SHEET

SPECIFIED THICKNESS in.	SPECIFIED WIDTH—in.				
	1/2 thru 1	Over 1 thru 2	Over 2 thru 4	Over 4 thru 10	Over 10
	TOLERANCE—in. in 6 ft. Allowable Deviation of a Side Edge from a Straight Line				
0.006-0.064	3/4	3/8	3/8	1/4	3/16
0.065-0.125 ^②	3/8	1/4	3/16

^②Tolerances applicable at ambient mill temperatures. A change in length of 0.013 in. per 100 in. per 10° F (6° C) must be recognized.

7

ALUMINUM(CONT)

PERMISSIBLE VARIATION OF ANSI H35.2 (PER ASTM B209)

3. sheet and plate

3.8 • LATERAL BOW FLAT SHEET AND PLATE

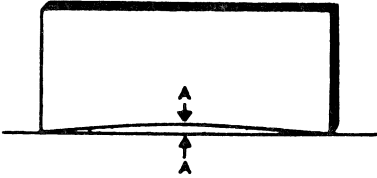
SPECIFIED WIDTH in.	SPECIFIED THICKNESS in.	ALLOWABLE DEVIATION OF A SIDE EDGE FROM A STRAIGHT LINE							
									
		SPECIFIED LENGTH—in.							
		Up thru 30	Over 30 thru 60	Over 60 thru 90	Over 90 thru 120	Over 120 thru 150	Over 150 thru 180	Over 180 thru 210	Over 210 thru 240
		TOLERANCE—in.							
Up thru 4	0.006-0.125	1/16	1/4	1/2	1	1 1/2	2	3	4
Over 4 thru 35	0.006-0.249	1/32	1/16	3/32	1/8	3/16	1	1 1/2	2
Over 35	0.006-0.249	1/32	1/16	3/32	1/8	3/16	5/16	7/16	1 1/2
Up thru 10	0.250-6.000	1/16	1/4	1/2	1	1 1/2	2	3	4
Over 10 thru 18	0.250-6.000	1/32	1/16	1/8	1/4	1 3/32	1 1/2	2 1/2	1
Over 18	0.250-6.000	1/32	1/16	3/32	1/8	3/16	5/16	7/16	1 1/2

3.9 • SQUARENESS FLAT SHEET AND PLATE

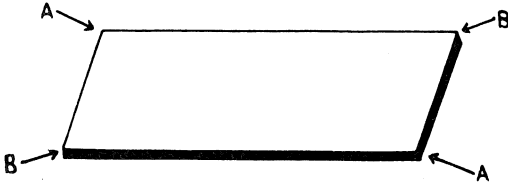
SPECIFIED LENGTH ft	SPECIFIED WIDTH—ft	
	Up thru 3	Over 3
	ALLOWABLE DIFFERENCE IN LENGTH OF DIAGONALS ④—in.	
		
	Maximum difference between AA and BB	
Up thru 12	3/32 x Width, ft ^③	
Over 12	9/64 x Width, ft ^③	
	5/64 x Width, ft ^③	
	7/64 x Width, ft ^③	

3.10 • DIAMETER ① SHEARED OR BLANKED SHEET AND PLATE CIRCLES

SPECIFIED THICKNESS in.	SPECIFIED DIAMETER—in.				
	Up thru 18	Over 18 thru 36	Over 36 thru 96	Over 96 thru 132	Over 132 thru 168
	ALLOWABLE DEVIATION FROM SPECIFIED DIAMETER in. Plus and Minus				
					
	Difference between AA and specified diameter				
0.006-0.249	1/32	3/64	1/16	1/8	3/16
0.250-0.375	...	1/16	1/8	3/16	1/4
0.376-0.625	...	1/8	3/16	1/4	3/8
0.626-0.875	...	3/16	1/4	3/8	1/2
0.876-1.250	...	1/4	3/8	1/2	5/8

3.11 • DIAMETER ① SAWED SHEET AND PLATE CIRCLES

SPECIFIED THICKNESS in.	SPECIFIED DIAMETER—in.			
	Up thru 18	Over 18 thru 60	Over 60 thru 132	Over 132 thru 168
	ALLOWABLE DEVIATION FROM SPECIFIED DIAMETER in. Plus and Minus			
				
	Difference between AA and specified diameter			
0.080-1.000	1/8	3/16	1/4	1/2
1.001-3.000	1/4	3/8	1/2	3/4

① When a dimension tolerance is specified other than as an equal bilateral tolerance, the value of the standard tolerance is that which would apply to the mean of the maximum and minimum dimensions permissible under the tolerance.

② Also applicable to any 240-inch increment of longer sheet or plate.

③ If specified width is other than an exact multiple of 12 in., tolerance

is determined by using the next largest exact multiple. For example, if specified width is 53 in. and specified length is 72 in., the tolerance is 5/64 in. x 5 = 25/64 in. This result is then rounded to 7/16 in. in accordance with footnote (4).

④ Use values for calculating only. Round result upward to nearest 1/16 in.

ALUMINUM(CONT)

PERMISSIBLE VARIATION OF ANSI H35.2 (PER ASTM B209)

3.12 • FLATNESS^① FLAT SHEET

Alloy (Includes Alclads)	Thickness in.	Longitudinal or Transverse Distances, ft, Center to Center of Buckles or Edge Waves ^②				
		Up thru 2	Over 2 thru 3	Over 3 thru 4	Over 4 thru 6	Over 6
		Tolerance, in. ^{③④⑤}				
EC, 1060, 1100, 3003, 3105, 5005, 5050, 5X57	0.020 thru 0.064 0.065 thru 0.249	1/8 1/8	3/16 3/16	3/16 5/16	5/16 3/8	3/8 1/2
3004, 3005, 5052, 5083, 5086, 5252, 5X54, 5456, 5652, brazing sheet, and all heat treatable alloys	0.020 thru 0.064 0.065 thru 0.249	3/16 3/16	3/16 5/16	5/16 3/8	3/8 1/2	1/2 9/16

3.13 • FLATNESS SAWED OR SHEARED PLATE

LONGITUDINAL FLATNESS	
SPECIFIED THICKNESS, in.	TOLERANCE ^③ in.—Allowable Deviation from Flat
	TX51 tempers ^⑥ Other than TX51 tempers ^{⑥⑪}
0.250-3.000 3.001-6.000	3/16 in any 6 ft ^⑦ 1/8 in any 6 ft or less 1/4 in any 6 ft or less 1/4 in any 6 ft or less

TRANSVERSE FLATNESS

SPECIFIED THICKNESS, in.	TOLERANCE ^③ in.—Allowable Deviation from Flat				
	Widths over 4 ft thru 6 ft ^⑧		Widths over 2 ft thru 4 ft		Widths 2 ft and less
	TX51 tempers ^⑥	Other than TX51 tempers ^{⑥⑪}	TX51 tempers ^⑦	Other than TX51 tempers ^{⑦⑪}	All tempers ^⑪
0.250-0.624 0.625-1.500 1.501-3.000 3.001-6.000	3/8 3/16 3/16 1/8	1/2 3/8 1/4 1/4	5/16 3/16 3/16 1/8	3/8 1/4 3/16 3/16	Only short-cycle flatness tolerance applies

SHORT-CYCLE FLATNESS^⑨

SPECIFIED THICKNESS, in.	TOLERANCE ^⑩ in.—Allowable Deviation from Flat	
	TX51 tempers ^⑥	Other than TX51 tempers ^{⑥⑪}
0.250-0.624 0.625-6.000	0.100 0.075	0.125 0.090

4. fin stock

4.1 • THICKNESS

SPECIFIED THICKNESS	TOLERANCE
in.	In. plus and minus
0.005-0.0104	.0005
0.0105-0.0169	.001
0.017-0.030	.0015

① Not applicable to cut-to-length sheet, panel flat sheet, coiled sheet, or sheet over 60 in. wide.

② Also applicable to overall length or width of sheet if only one longitudinal and/or transverse buckle or edge wave is present.

③ As measured with sheet or plate resting on flat surface concave side upward, using a straightedge and a feeler gauge, dial gauge or scale.

④ Not applicable to annealed (O temper) or HX8 temper.

⑤ Not applicable to end or corner turnout.

⑥ TX51 is a general designation for the following stress-relieved tempers: T351, T451, T651, T851, T6151, T7351 and T7651.

4.2 • WIDTH AND LATERAL BOW^⑫

Same as for coiled sheet.
See tables 3.6 and 3.7

⑦ For lengths under 6 ft, the tolerance is 1/8 in.

⑧ For widths over 6 ft, these tolerances apply for any 6 ft of total width.

⑨ Short-cycle flatness is the flatness over any 2-ft span in any direction.

⑩ As measured with the plate resting on a flat surface, and by use of a frame with rollers mounted on 2-ft centers and a depth gauge in the center.

⑪ Not applicable to annealed (O temper) plate in any alloy or F temper plate in heat-treatable alloys.

⑫ Tolerances for thicknesses of 0.005-0.0059 inch are the same as those specified for thickness of 0.006 inch.

ALUMINUM(CONT)

(PER ASTM B373)

DIMENSIONAL TOLERANCES

The foil width shall not vary from that specified on the purchase order by more than ± 0.016 inch for widths under 12 inch, ± 0.031 inch for width 12 inches and over.

TENSILE BREAKING LOAD	
NOMINAL THICKNESS	BREAKING LOAD, MIN. LBF/IN. OF WIDTH
.00017	1.1
.00020	1.3
.00023	1.5
.00025	1.6
.00030	1.9
.00035	2.3
.00040	2.6
.00045	2.9
.00050	3.2

NOTES

COST CODE (CC COLUMN)

CODE	A	B	C	D	E	F	G	H	I	J	K	L	M	N	O
≈ VALUE with +	.75¢	2¢	3.75¢	6¢	10¢	18¢	35¢	60¢	\$1	\$2	\$3.75	\$6	\$10	\$18	\$35+
≈ VALUE no suffix	.5¢	1.5¢	3¢	5¢	8¢	15¢	25¢	50¢	75¢	\$1.50	\$3	\$5	\$8	\$15	\$25
≈ VALUE with -	.2¢	1.25¢	2.5¢	4.25¢	7¢	13¢	22¢	40¢	65¢	\$1.25	\$2.50	\$4.25	\$7	\$13	\$22

NOTE: Costs may vary from order to order due to order quantities, vendor, etc.

ALUMINUM(CONT)

WEIGHT(LBS PER FT) BAR AND WIRE

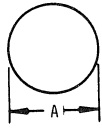

2011-T3 ROUND ALUMINUM ROD
STANDARD SCREW MACHINE STOCK
Specific 12 Foot Lengths

DIMENSION "A" INCHES	POUNDS PER FOOT	POUNDS 12' LENGTH
3/32	.0084	.101
1/8	.015	.180
9/64	.019	.228
5/32	.023	.276
11/64	.028	.336
3/16	.034	.408
13/64	.040	.480
7/32	.046	.552
15/64	.053	.636
1/4	.060	.720
17/64	.068	.816
9/32	.076	.912
19/64	.085	1.02
5/16	.094	1.13
11/32	.113	1.36
3/8	.135	1.62
25/64	.147	1.76
13/32	.158	1.90
7/16	.184	2.21
15/32	.211	2.53
1/2	.240	2.88
17/32	.271	3.25
35/64	.287	3.44
9/16	.304	3.65
19/32	.338	4.06
5/8	.375	4.50
21/32	.413	4.96
43/64	.434	5.21
11/16	.454	5.45
23/32	.496	5.95
3/4	.540	6.48
25/32	.586	7.03
13/16	.634	7.61
7/8	.735	8.82
15/16	.843	10.1
1	.960	11.5
1-1/32	1.02	12.2
1-1/16	1.08	13.0
1-1/8	1.21	14.5
1-5/32	1.28	15.4

DIMENSION "A" INCHES	POUNDS PER FOOT	POUNDS 12' LENGTH
1-3/16	1.35	16.2
1-1/4	1.50	18.0
19/32	1.58	19.0
1-5/16	1.65	19.8
1-3/8	1.81	21.7
1-7/16	1.98	23.8
1-1/2	2.16	25.9
1-9/16	2.34	28.1
1-5/8	2.53	30.4
1-11/16	2.73	32.8
1-3/4	2.94	35.3
1-13/16	3.15	37.8
1-7/8	3.37	40.4
1-15/16	3.60	43.2
2	3.84	46.1
2-1/16	4.08	49.0
2-1/8	4.33	52.0
2-3/16	4.59	55.1
2-1/4	4.86	58.3
2-5/16	5.13	61.6
2-3/8	5.41	64.9
2-7/16	5.70	68.4
2-1/2	6.00	72.0
2-9/16	6.30	75.6
2-5/8	6.61	79.3
2-3/4	7.26	87.1
2-7/8	7.93	95.2
3	8.64	104.
3-1/8	9.37	112.
3-1/4	10.13	122.
3-1/2*	11.75	141.
3-3/4*	13.49	162.

* T4 condition only - Rolled Rod.
2-3/8" thru 3 1/4" Cold Finished Rod.

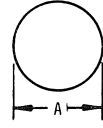

2024-T351 ROUND ALUMINUM ROD
STANDARD SCREW MACHINE STOCK
Specific 12 Foot Lengths

DIMENSION "A" INCHES	POUNDS PER FOOT	POUNDS 12' LENGTH
1/8	.0148	.178
3/16	.0330	.396
15/64	.0515	.621
1/4	.0588	.706
3/16	.0918	1.10
3/8	.132	1.58
13/32	.155	1.86
7/16	.180	2.16
1/2	.235	2.82
9/16	.298	3.58
5/8	.367	4.40
11/16	.444	5.33
3/4	.529	6.35
13/16	.621	7.45
7/8	.720	8.64
15/16	.827	9.92
1	.940	11.3
1-1/16	1.06	12.7
1-1/8	1.19	14.3
1-3/16	1.33	16.0
1-1/4	1.47	17.6
1-5/16	1.62	19.4
1-3/8	1.78	21.4
1-7/16	1.94	23.3
1-1/2	2.12	25.4
1-9/16	2.30	27.6
1-5/8	2.48	29.8
1-11/16	2.68	32.2
1-3/4	2.88	34.6
1-13/16	3.09	37.1

DIMENSION "A" INCHES	POUNDS PER FOOT	POUNDS 12' LENGTH
1-7/8	3.31	39.7
1-15/16	3.53	42.4
2	3.76	45.1
2-1/16	4.00	48.0
2-1/8	4.25	51.0
2-3/16	4.50	54.0
2-1/4	4.76	57.1
2-3/8	5.30	63.6
2-1/2	5.88	70.6
2-5/8	6.48	77.8
2-3/4	7.11	85.3
2-7/8	7.77	93.2
3	8.46	102.
3-1/8	9.18	110.
3-1/4	9.93	119.
3-3/8	10.7	128.
3-1/2	11.5	138.
3-3/4	13.2	158.
4	15.0	180.
4-1/4	17.0	204.
4-1/2	19.0	228.
4-3/4	21.2	254.
5	23.5	282.
5-1/4	25.9	311.
5-1/2	28.5	342.
5-3/4	31.1	373.
6	33.9	407.
6-1/2	39.8	478.
7	46.2	554.
8	60.3	724.

1/8" thru 5/16" - Drawn Rod.
3/8" thru 3-3/8" - Cold Finished Rod.
3-1/2" and over - Rolled Rod.

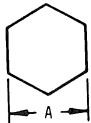

2024-T351 HEXAGON ALUMINUM BAR
STANDARD SCREW MACHINE STOCK
COLD FINISHED
Specific 12 Foot Lengths

DIMENSION "A" INCHES	POUNDS PER FOOT	POUNDS 12' LENGTH
3/16	.0365	.438
1/4	.0643	.772
5/16	.101	1.21
3/8	.146	1.75
7/16	.199	2.39
1/2	.260	3.12
9/16	.328	3.94
5/8	.405	4.86
11/16	.490	5.88
3/4	.583	7.00
13/16	.685	8.22
7/8	.794	9.53
15/16	.910	10.9
1	1.04	12.5
1-1/8	1.31	15.7

DIMENSION "A" INCHES	POUNDS PER FOOT	POUNDS 12' LENGTH
1-1/4	1.62	19.4
1-3/8	1.96	23.5
1-7/16	2.14	25.7
1-1/2	2.33	28.0
1-5/8	2.74	32.9
1-11/16	2.95	35.4
1-3/4	3.18	38.2
1-13/16	3.41	40.9
1-7/8	3.64	43.7
2	4.15	49.8
2-1/8	4.68	56.2
2-1/4	5.25	63.0
2-1/2	6.48	77.8
2-3/4	7.84	94.1
3	9.33	112.

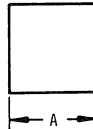

2024-T351 SQUARE ALUMINUM BAR
COLD FINISHED - ROLLED
Standard 12 Foot Lengths

DIMENSION "A" INCHES	POUNDS PER FOOT	POUNDS 12' LENGTH
3/16	.0421	.505
1/4	.0748	.898
3/8	.169	2.03
7/16	.229	2.75
1/2	.300	3.60
9/16	.379	4.55
5/8	.469	5.63
3/4	.675	8.10
7/8	.919	11.0
1	1.20	14.4
1-1/8	1.52	18.2
1-1/4	1.88	22.6
1-3/8	2.27	27.2

DIMENSION "A" INCHES	POUNDS PER FOOT	POUNDS 12' LENGTH
1-1/2	2.70	32.4
1-5/8	3.17	38.0
1-3/4	3.67	44.0
2	4.80	57.6
#2-1/4	6.08	73.0
#2-1/2	7.50	90.0
2-5/8	8.27	99.2
#2-3/4	9.08	109.
#3	10.8	130.
3-1/4	12.7	152.
3-1/2	14.7	176.
4	19.2	230.

ALUMINUM(CONT)

WEIGHT(LBS PER FT) BAR AND WIRE

2024-T351 RECTANGULAR ALUMINUM BAR
COLD-FINISHED, ROLLED **[R]**,
OR EXTRUDED **[E]**
Random 12 Foot Lengths

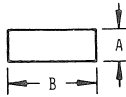

DIMENSION "A" INCHES	DIMENSION "B" INCHES	POUNDS PER FOOT	POUNDS 12' LENGTH			
1/8	x 1/2	.0750	.900			
	5/8	.0937	1.12			
	3/4	.113	1.36			
	1	.150	1.80			
	1-1/4	.188	2.26			
	1-1/2	.225	2.70			
	2	.300	3.60			
	3/16	x 1/2	.113	1.36		
		5/8	.141	1.69		
		3/4	.169	2.03		
1		.225	2.70			
1-1/4		.281	3.37			
1-1/2		.338	4.06			
2		.450	5.40			
1/4		x 1/2	.150	1.80		
		5/8	.188	2.26		
		3/4	.225	2.70		
	7/8	.263	3.16			
	1	.300	3.60			
	1-1/4	.375	4.50			
	1-1/2	.450	5.40			
	2	.600	7.20			
	2-1/2	.750	9.00			
	3	.900	10.8			
5/16	x 1/2	.188	2.26			
	5/8	.234	2.81			
	3/4	.281	3.37			
	1	.375	4.50			
	1-1/4	.469	5.63			
	1-1/2	.563	6.76			
	2	.750	9.00			
	3/8	x 1/2	.225	2.70		
		5/8	.281	3.37		
		3/4	.338	4.06		
1		.450	5.40			
1-1/4		.563	6.76			
1-1/2		.675	8.10			
1-3/4		.788	9.43			
2		.900	10.8			
2-1/2		1.13	13.6			
3		1.35	16.2			
1/2	x 5/8	.375	4.50			
	3/4	.450	5.40			
	7/8	.525	6.30			
	1	.600	7.20			
	1-1/4	.750	9.00			
	1-1/2	.900	10.8			
	1-3/4	1.05	12.6			
	2	1.20	14.4			
	2-1/2	1.50	18.0			
	3	1.80	21.6			
5/8	x 3/4	.563	6.76			
	7/8	.657	7.88			
	1	.750	9.00			
	1-1/4	.938	11.3			
	1-1/2	1.13	13.6			
	2	1.50	18.0			
	1	x 1-1/4	1.50	18.0		
		1-1/2	1.80	21.6		
		1-3/4	2.10	25.2		
		2	2.40	28.8		
2-1/2		3.00	36.0			
3		3.60	43.2			
3-1/2		4.20	50.4			
4		4.80	57.6			
6		7.20	86.4			
1-1/8		x 1-3/4	2.36	28.3		
	1-1/2	2.25	27.0			
	2	3.00	36.0			
	2-1/2	3.75	45.0			
	3	4.50	54.0			
	6	9.00	108.0			
	1-1/4	x 2	3.60	43.2		
		2-1/2	4.50	54.0		
		3	5.40	64.8		
		4	7.20	86.4		
6		10.8	130.0			
8		14.4	173.0			
1-3/4		x 2	4.20	50.4		
		3	6.30	75.6		
		4	8.40	101.0		
		2	x 2-1/4	5.40	64.8	
	2-1/2		6.00	72.0		
	3		7.20	86.4		
	4		9.60	115.0		
	6		14.4	173.0		
	2-1/4		x 4	10.8	130.0	
			2-1/2	x 3	9.00	108.0
4				12.0	144.0	
4-1/2				13.5	162.0	
5				15.0	180.0	
6		18.0		216.0		
2-3/4		x 4		13.2	158.0	
		3		x 4	14.4	173.0
				5	18.0	216.0
				6	21.6	259.0

6061-T651 ROUND ALUMINUM ROD
COLD FINISHED - ROLLED
Specific 12 Foot Lengths

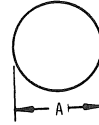

DIMENSION "A" INCHES	POUNDS PER FOOT	POUNDS 12' LENGTH
1/8	.0145	.174
3/16	.0324	.389
1/4	.0576	.680
5/16	.0900	1.08
3/8	.130	1.56
7/16	.176	2.11
15/32	.202	2.42
1/2	.230	2.76
9/16	.291	3.49
5/8	.360	4.32
11/16	.435	5.22
3/4	.518	6.22
13/16	.608	7.30
7/8	.705	8.46
15/16	.810	9.72
1	.921	11.1
1-1/8	1.17	14.0
1-3/16	1.30	15.6
1-1/4	1.44	17.3
1-5/16	1.59	19.1
1-3/8	1.74	20.9
1-7/16	1.90	22.8
1-1/2	2.07	24.8
1-9/16	2.25	27.0

DIMENSION "A" INCHES	POUNDS PER FOOT	POUNDS 12' LENGTH
1-5/8	2.43	29.2
1-3/4	2.82	33.8
1-13/16	3.03	36.4
1-7/8	3.24	38.9
2	3.68	44.2
2-1/8	4.16	49.9
2-1/4	4.66	55.9
2-3/8	5.20	62.4
2-1/2	5.76	69.1
2-5/8	6.35	76.2
2-3/4	6.97	83.6
2-7/8	7.61	91.3
3	8.29	99.5
3-1/4	9.72	117.0
3-1/2	11.3	136.0
3-3/4	13.0	156.0
4	14.7	176.0
4-1/2	18.7	224.0
5	23.1	277.0
5-1/2	28.0	336.0
6	33.2	398.0
6-1/2	38.9	467.0
7	45.2	542.0
8	59.0	708.0

Under 3 1/2" diameter - Cold Finished Rod.
3 1/2" and over - Rolled Rod.

6061-T651 HEXAGON ALUMINUM BAR
COLD FINISHED
Specific 12 Foot Lengths

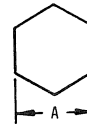

DIMENSION "A" INCHES	POUNDS PER FOOT	POUNDS 12' LENGTH
1/4	.0629	.755
3/8	.143	1.72
7/16	.194	2.33
1/2	.254	3.05
9/16	.321	3.85
5/8	.397	4.76
11/16	.480	5.76
3/4	.571	6.85
13/16	.671	8.05
7/8	.778	9.34
15/16	.892	10.7
1	1.01	12.1
1-1/16	1.15	13.8
1-1/8	1.28	15.4
1-3/16	1.43	17.2
1-1/4	1.58	19.0
1-9/32	1.67	20.0

DIMENSION "A" INCHES	POUNDS PER FOOT	POUNDS 12' LENGTH
1-5/16	1.75	21.0
1-3/8	1.92	23.1
1-7/16	2.10	25.2
1-1/2	2.28	27.4
1-9/16	2.48	29.8
1-5/8	2.69	32.2
1-11/16	2.99	34.7
1-3/4	3.11	37.3
1-7/8	3.57	42.8
1-15/16	3.81	45.9
2	4.06	48.7
2-1/8	4.59	55.1
2-1/4	5.14	61.7
2-5/16	5.45	65.4
2-1/2	6.35	76.2
2-5/8	7.00	84.0

6061-T6511 SQUARE ALUMINUM BAR
EXTRUDED
Standard 12 Foot Lengths

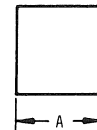

DIMENSION "A" INCHES	POUNDS PER FOOT	POUNDS 12' LENGTH
1/2	.293	3.52
5/8	.458	5.50
3/4	.660	7.92
1	1.17	14.0

DIMENSION "A" INCHES	POUNDS PER FOOT	POUNDS 12' LENGTH
1-1/4	1.83	22.0
1-1/2	2.38	28.6
2	4.69	56.3
3-1/4	12.4	149.0

7

ALUMINUM(CONT)

WEIGHT(LBS PER FT) BAR AND WIRE

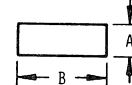

**6061-T6511 RECTANGULAR
EXTRUDED ALUMINUM BAR**
Standard 12 Foot Lengths

DIMENSION "A" INCHES	DIMENSION "B" INCHES	POUNDS PER FOOT	POUNDS 12' LENGTH
1/8	x 1	.147	1.76
	1-1/4	.184	2.21
	1-1/2	.221	2.64
	1-3/4	.257	3.08
	2	.294	3.53
	2-1/2	.368	4.42
3/16	x 3/4	.165	1.98
	1	.221	2.65
	1-1/4	.276	3.31
1/4	x 3/4	.221	2.65
	1	.294	3.53
	1-1/4	.368	4.42
5/16	x 3/4	.276	3.31
	1	.368	4.42
	1-1/4	.459	5.51
	1-1/2	.551	6.61
	2	.735	8.82
	3	1.10	13.2
3/8	x 1/2	.221	2.65
	3/4	.331	3.97
	1	.441	5.29
	1-1/4	.551	6.61
3/8	x 1-3/4	.772	9.26
	2	.882	10.6
	2-1/2	1.10	13.2
	3	1.32	15.8
	4	1.76	21.1
	6	2.65	31.8
1/2	x 3/4	.441	5.29
	1	.588	7.07
	1-1/4	.735	8.82
	1-1/2	.882	10.6
2	x 3/4	1.03	12.2
	1	1.18	14.2
	1-1/4	1.47	17.6
	1-1/2	1.76	21.1
	2	2.35	28.2
	3	2.94	35.3
3	x 3/4	3.53	42.4
	1	4.42	52.9
	1-1/4	5.51	66.1
	1-1/2	6.61	79.3
	2	9.26	110.6
	3	13.2	158.4

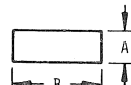

6063-T5 RECTANGULAR ALUMINUM BAR
EXTRUDED - SHARP CORNERS
16 Foot Lengths

DIMENSION "A" INCHES	DIMENSION "B" INCHES	POUNDS PER FOOT	POUNDS 16' LENGTH
1/8	x 1/2	.0735	1.18
	5/8	.0918	1.47
	3/4	.110	1.76
	1	.147	2.35
	1-1/4	.184	2.94
	1-1/2	.221	3.54
3/16	x 1/2	.111	1.78
	3/4	.165	2.64
	1	.221	3.54
	1-1/4	.276	4.42
	1-1/2	.331	5.30
	2	.441	7.06
1/4	x 1/2	.147	2.35
	5/8	.184	2.94
	3/4	.221	3.54
	1	.294	4.70
	1-1/4	.368	5.89
	1-1/2	.441	7.07
1/2	x 1/2	.221	3.54
	3/4	.331	5.30
	1	.441	7.06
	1-1/4	.551	8.82
	1-1/2	.662	10.6
	2	.882	14.2
3/8	x 1/2	.221	3.54
	3/4	.331	5.30
	1	.441	7.06
	1-1/4	.551	8.82
	1-1/2	.662	10.6
	2	.882	14.2
1	x 1/2	.441	7.06
	3/4	.662	10.6
	1	.882	14.2
	1-1/4	1.10	17.6
	1-1/2	1.32	21.1
	2	1.76	28.2

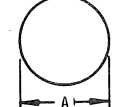

6262-T9 ROUND ALUMINUM ROD
COLD FINISHED
STANDARD SCREW MACHINE STOCK
Specific 12 Foot Lengths

DIMENSION "A" INCHES	POUNDS PER FOOT	POUNDS 12' LENGTH
1/8	.0145	.174
3/16	.0324	.389
1/4	.0576	.691
5/16	.090	1.08
3/8	.130	1.56
7/16	.176	2.11
15/32	.202	2.42
1/2	.230	2.76
9/16	.291	3.49
5/8	.360	4.32
3/4	.518	6.22
13/16	.608	7.30
7/8	.705	8.46
1	.921	11.1
1-1/8	1.17	14.0
1-1/4	1.44	17.3
1-5/16	1.59	19.1
1-3/8	1.74	20.9
1-1/2	2.07	24.8
1-5/8	2.43	29.2
1-3/4	2.82	33.8
1-7/8	3.24	38.9
2	3.68	44.2
2-1/8	4.16	49.9
2-1/4	4.66	55.9
2-1/2	5.76	69.1
2-3/4	6.97	83.6
3	8.29	99.5
3-1/4	9.73	117.0

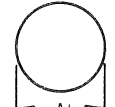

7075-T6510 ROUND ALUMINUM ROD
COLD FINISHED - ROLLED
Standard 12 Foot Lengths

DIMENSION "A" INCHES	POUNDS PER FOOT	POUNDS 12' LENGTH
3/8	.134	1.61
1/2	.237	2.84
5/8	.379	4.45
3/4	.534	6.41
13/16	.627	7.52
7/8	.727	8.72
1	.950	11.4
1-1/8	1.20	14.4
1-1/4	1.48	17.8
1-3/8	1.80	21.6
1-1/2	2.14	25.7
1-5/8	2.51	30.1
1-3/4	2.91	34.9
2	3.80	45.6
2-1/4	4.81	57.7
2-1/2	5.94	71.3
2-5/8	6.54	78.5
2-3/4	7.18	86.2
3	8.55	103.
3-1/2	11.6	139.
4	15.2	182.
4-1/4	17.2	206.
4-1/2	19.2	230.
5	23.7	284.
5-1/2	28.8	346.
6	34.2	410.

3 1/2" and under - Cold Finished Rod.
Over 3 1/2" diameter - Rolled Rod.

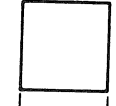

6063-T5 SQUARE ALUMINUM BAR
EXTRUDED - SHARP CORNERS
16 Foot Lengths

DIMENSION "A" INCHES	POUNDS PER FOOT	POUNDS 12' LENGTH
1/4	.0732	1.17
3/8	.165	2.64
1/2	.294	4.70
5/8	.459	7.34
3/4	.662	10.6
1	1.18	18.9
1-1/4	1.84	29.4
1-1/2	2.65	42.4
2	4.70	75.2

ALUMINUM(CONT)

WEIGHT(LBS PER FT) BAR, SHEET, COIL & PLATE

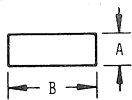

7075-T6510 RECTANGULAR ALUMINUM BAR
COLD FINISHED - ROLLED (R)
Random 12 Foot Lengths

DIMENSION "A" INCHES	DIMENSION "B" INCHES	POUNDS PER FOOT	POUNDS 12' LENGTH
1/4	x 1	.303	3.64
	x 1-1/2	.455	5.46
	x 3	.909	10.9
3/8	x 1	.455	5.46
	x 1-1/2	.909	10.9
1/2	x 1-1/2	.909	10.9
	x 4	2.42	29.0
5/8	x 1	.758	9.10
	x 3	2.73	32.8
1	x 1-3/4	2.12	25.4
	x 2	2.42	29.0
	x 3 (R)	3.64	43.7
	x 4 (R)	4.85	58.2
1-1/4	x 3 (R)	4.55	54.6
	x 2-1/2 (R)	4.55	54.6
1-1/2	x 2-1/2 (R)	4.55	54.6
	x 4 (R)	7.27	87.2
2	x 2-1/2 (R)	6.05	72.7
	x 3 (R)	7.27	87.2
	x 4 (R)	9.70	116.
	x 6 (R)	14.5	174.
2-1/2	x 4 (R)	12.1	145.
	x 6 (R)	18.1	217.
3	x 4 (R)	14.5	174.
	x 4-1/2 (R)	16.0	192.
	x 6 (R)	22.0	264.

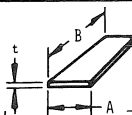

3003-H14 ALUMINUM FLAT SHEET
MILL FINISH

THICKNESS "t" INCHES	WIDTH "A" INCHES	LENGTH "B" INCHES	POUNDS SQUARE FOOT	POUNDS PER SHEET
.012	24	72	.171	2.05
.016	24	72	.228	2.74
.016	36	96	.228	5.48
.020	24	72	.285	3.42
.020	36	96	.285	6.84
.020	36	120	.285	8.55
.025	36	96	.356	8.54
.025	36	120	.356	10.7
.025	36	144	.356	12.8
.025	48	96	.356	11.4
.025	48	120	.356	14.2
.025	48	144	.356	17.1
.032	24	72	.456	5.47
.032	36	96	.456	10.9
.032	36	120	.456	13.7
.032	36	144	.456	16.4
.032	48	96	.456	14.6
.032	48	120	.456	18.2
.032	48	144	.456	21.9
.040	36	96	.570	13.7
.040	36	120	.570	17.1
.040	36	144	.570	20.5
.040	48	96	.570	18.2
.040	48	120	.570	22.8
.040	48	144	.570	27.4
.050	36	96	.713	17.1
.050	36	120	.713	21.4
.050	36	144	.713	25.7
.050	48	96	.713	22.8
.050	48	120	.713	28.5
.050	48	144	.713	34.2
.050	60	144	.713	42.8
.063	36	96	.898	21.6
.063	36	120	.898	26.9
.063	36	144	.898	32.3
.063	48	96	.898	28.7
.063	48	120	.898	35.9
.063	48	144	.898	43.1
.063	60	144	.898	53.9
.080	36	96	1.14	27.4
.080	48	120	1.14	45.6
.080	48	144	1.14	54.7
.090	36	96	1.28	30.7
.090	48	120	1.28	51.2
.090	48	144	1.28	61.4
.100	36	96	1.43	34.3
.100	48	144	1.43	68.6
.125	36	96	1.78	42.7
.125	36	120	1.78	53.4
.125	48	120	1.78	71.2
.125	48	144	1.78	85.4
.125	60	144	1.78	107.
.160	48	144	2.28	109.
.190	36	96	2.71	65.0
.190	48	120	2.71	108.
.190	48	144	2.71	130.

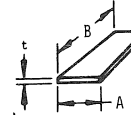

5005-H34 ALUMINUM FLAT SHEET
MILL FINISH

THICKNESS "t" INCHES	WIDTH "A" INCHES	LENGTH "B" INCHES	POUNDS SQUARE FOOT	POUNDS PER SHEET
.012	24	72	.169	2.03
.016	24	72	.226	2.71
.020	24	72	.282	3.38
.020	36	96	.282	6.77
.025	36	96	.353	8.47
.025	48	96	.353	11.3
.025	48	120	.353	14.1
.025	48	144	.353	16.9
.032	24	72	.452	5.42
.032	36	96	.452	10.9
.032	36	120	.452	13.6
.032	48	96	.452	14.5
.032	48	120	.452	18.1
.032	48	144	.452	21.7
.040	36	96	.564	13.5
.040	36	120	.564	16.9
.040	36	144	.564	20.3
.040	48	96	.564	18.1
.040	48	120	.564	22.6
.040	48	144	.564	27.1
.050	36	96	.706	16.9
.050	36	120	.706	21.2
.050	48	96	.706	22.6
.050	48	120	.706	28.2
.050	48	144	.706	33.9
.063	36	96	.889	21.3
.063	36	120	.889	26.7
.063	48	96	.889	28.5
.063	48	120	.889	35.6
.063	48	144	.889	42.7
.080	48	144	1.13	54.2
.090	36	96	1.27	30.5
.090	48	144	1.27	61.0
.100	48	144	1.41	67.7
.125	36	96	1.76	42.2
.125	48	96	1.76	56.3
.125	48	120	1.76	70.4
.125	48	144	1.76	84.5
.160	48	144	2.26	108.
.190	48	144	2.68	129.
.250	48	144	3.53	169.

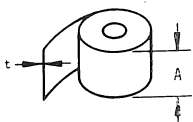

3003-H14 ALUMINUM IN COILS
MILL FINISH

THICKNESS "t" INCHES	WIDTH "A" INCHES	POUNDS LINEAL FOOT
.010	12	.143
.016	18	.342
.016	24	.456
.016	36	.684
.016	48	.912
.018	36	.769
.020	36	.855
.025	24	.712
.025	36	1.07
.025	48	1.42
.032	24	.912
.032	36	1.37
.032	48	1.82
.040	24	1.14
.040	36	1.71
.040	48	2.28
.050	24	1.43
.050	36	2.14
.050	48	2.85
.063	24	1.80
.063	36	2.69
.063	48	3.59
.080	36	3.42
.080	48	4.56
.090	36	3.84
.090	48	5.12
.100	36	4.29
.100	48	5.72
.125	36	5.34

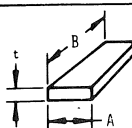

3003-H14 ALUMINUM PLATE
MILL FINISH-SHEARED EDGES

THICKNESS "t" INCHES	WIDTH "A" INCHES	LENGTH "B" INCHES	POUNDS SQUARE FOOT	POUNDS PER PLATE
1/4	48	144	3.56	171.
3/8	36	96	5.35	128.
3/8	48	144	5.35	256.
1/2	36	96	7.13	171.

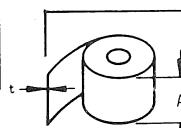

5005-H34 ALUMINUM IN COILS
MILL FINISH

THICKNESS "t" INCHES	WIDTH "A" INCHES	POUNDS LINEAL FOOT
.016	36	.678
.020	36	.846
.025	24	.706
.025	36	1.06
.032	36	1.36
.032	48	1.81
.040	36	1.69
.040	48	2.26
.050	36	2.12
.050	48	2.82
.063	36	2.67
.063	48	3.56
.090	36	3.81
.125	36	5.28

ALUMINUM(CONT)

WEIGHT(LBS PER FT) COIL, SHEET, & PLATE

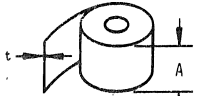

5052-H32 ALUMINUM IN COILS
MILL FINISH

THICKNESS "t" INCHES	WIDTH "A" INCHES	POUNDS LINEAL FOOT
.020	36	.840
.025	36	1.05
.032	36	1.34
.032	48	1.79
.040	36	1.68
.040	48	2.24
.050	36	2.09
.050	48	2.79
.063	36	2.64
.063	48	3.52
.080	36	3.36
.080	48	4.48
.090	36	3.78

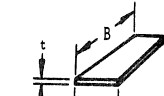

5052-H32 ALUMINUM FLAT SHEET
MILL FINISH

THICKNESS "t" INCHES	WIDTH "A" INCHES	LENGTH "B" INCHES	POUNDS SQUARE FOOT	POUNDS PER SHEET
.020	36	96	.278	6.67
.025	36	96	.349	8.38
.025	48	144	.349	16.7
.032	36	96	.447	10.7
.032	36	120	.447	13.4
.032	48	96	.447	14.3
.032	48	120	.447	17.9
.032	48	144	.447	21.5
.040	36	96	.559	13.4
.040	36	120	.559	16.8
.040	48	96	.559	17.9
.040	48	120	.559	22.4
.040	48	144	.559	26.8
.050	36	96	.698	16.8
.050	36	120	.698	20.9
.050	48	96	.698	22.3
.050	48	120	.698	27.9
.050	48	144	.698	33.5
.063	36	96	.880	21.1
.063	48	96	.880	28.2
.063	48	120	.880	35.2
.063	48	144	.880	42.2
.080	36	96	1.12	26.9
.080	48	96	1.12	35.8
.080	48	144	1.12	53.8
.090	36	96	1.26	30.2
.090	48	96	1.26	40.3
.090	48	144	1.26	60.5
.100	48	144	1.40	67.2
.125	36	96	1.75	42.0
.125	48	144	1.75	84.0
.160	48	144	2.23	107.
.190	36	96	2.65	63.6
.190	48	144	2.65	127.
.250	48	144	3.49	168.
.312	48	144	4.37	210.
.375	48	144	5.24	252.
.500	48	144	6.98	335.
.750	48	144	10.5	503.
1.00	48	144	14.0	670.

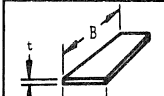

5052-H34 ALUMINUM FLAT SHEET
MILL FINISH

THICKNESS "t" INCHES	WIDTH "A" INCHES	LENGTH "B" INCHES	POUNDS SQUARE FOOT	POUNDS PER SHEET
.020	36	96	.279	6.67
.025	36	96	.349	3.38
.032	36	96	.447	10.7
.032	36	120	.447	13.4
.032	48	96	.447	14.3
.032	48	120	.447	17.9
.032	48	144	.447	21.5
.040	36	96	.559	13.4
.040	36	120	.559	16.8
.040	48	96	.559	17.9
.040	48	120	.559	22.4
.040	48	144	.559	26.8
.050	36	96	.698	16.8
.050	36	120	.698	20.9
.050	48	96	.698	22.3
.050	48	120	.698	27.9
.050	48	144	.698	33.5
.063	36	96	.880	21.1
.063	48	96	.880	28.2
.063	48	120	.880	35.2
.063	48	144	.880	42.2
.080	48	144	1.12	53.8
.090	36	96	1.26	30.2
.090	48	144	1.26	60.5
.100	48	144	1.40	67.2
.125	48	144	1.75	84.0
.190	48	144	2.65	127.
.250	48	144	3.49	167.

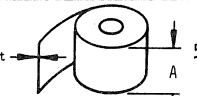

5052-H34 ALUMINUM IN COILS
MILL FINISH

THICKNESS "t" INCHES	WIDTH "A" INCHES	POUNDS LINEAL FOOT
.016	36	.669
.020	36	.840
.025	36	1.05
.032	36	1.34
.032	48	1.79
.040	36	1.68
.040	48	2.24
.050	36	2.09
.050	48	2.79
.063	36	2.64
.063	48	3.52
.090	36	3.78

5657-H25

THICKNESS "t" INCHES	WIDTH "A" INCHES	LENGTH "B" INCHES	POUNDS SQUARE FOOT	POUNDS PER SHEET
.032	48	144	.452	21.7
.040	48	144	.564	27.1
.048	48	144	.664	31.9

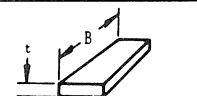

2024-T351 (FORMERLY 2024-T4)
BARE ALUMINUM FLAT PLATE
MILL FINISH OILED AND IDENTIFIED

THICKNESS "t" INCHES	WIDTH "A" INCHES	LENGTH "B" INCHES	POUNDS SQUARE FOOT	POUNDS PER PLATE
.250	36	96	3.60	86.4
.250	48	144	3.60	173.
.313	36	96	4.51	108.
.313	48	144	4.51	217.
.375	36	96	5.40	130.
.375	48	144	5.40	259.
.375	60	144	5.40	324.
.500	36	96	7.20	173.
.500	48	144	7.20	346.
.625	36	96	9.00	216.
.625	48	144	9.00	432.
.750	36	96	10.8	259.
.750	48	144	10.8	518.
1.00	48	144	14.4	346.
1.00	48	144	14.4	691.
1.25	24	72	18.0	216.
1.25	36	96	18.0	432.
1.25	48	144	18.0	864.
1.50	24	72	21.6	259.
1.50	36	96	21.6	518.
1.50	48	144	21.6	1037.
1.75	24	72	25.2	302.
1.75	36	96	25.2	605.
2.00	24	72	28.8	346.
2.00	36	96	28.8	691.
2.00	48	144	28.8	1382.
2.50	36	96	36.0	864.
2.50	48	144	36.0	1728.
3.00	36	96	43.2	1037.
3.00	48	144	43.2	2074.
3-1/2	41	146	50.4	2095.
3-1/2	48	144	50.4	2419.
4	48	144	57.6	2765.

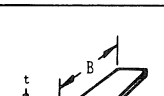

6061-T6 ALUMINUM FLAT SHEET
MILL FINISH-OILED AND IDENTIFIED

THICKNESS "t" INCHES	WIDTH "A" INCHES	LENGTH "B" INCHES	POUNDS SQUARE FOOT	POUNDS PER SHEET
.020	36	96	.282	6.77
.025	36	144	.353	12.7
.032	48	144	.452	21.7
.040	36	96	.564	13.5
.040	48	96	.564	18.1
.040	48	144	.564	27.1
.050	48	144	.706	33.9
.050	48	96	.706	22.6
.063	48	144	.889	42.7
.063	60	144	.889	53.3
.080	48	144	1.13	54.2
.090	30	96	1.27	25.4
.090	36	96	1.27	30.5
.090	48	144	1.27	61.0
.100	48	144	1.41	67.7
.125	48	144	1.76	84.5
.125	60	144	1.76	106.
.160	48	144	2.26	108.
.190	48	144	2.68	129.

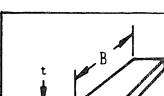

6061-T651 (FORMERLY 6061-T6)
ALUMINUM FLAT PLATE
MILL FINISH-OILED AND IDENTIFIED

THICKNESS "t" INCHES	WIDTH "A" INCHES	LENGTH "B" INCHES	POUNDS SQUARE FOOT	POUNDS PER PLATE
.250	36	96	3.53	84.7
.250	48	84	3.53	98.8
.250	48	144	3.53	169.
.250	50	148-1/4	3.53	177.
.250	60	144	3.53	212.
.313	48	144	4.42	212.
.375	48	144	5.29	254.
.375	49	147	5.29	265.
.375	60	144	5.29	317.
.500	36	96	7.06	169.
.500	48	144	7.06	339.
.500	60	144	7.06	423.
.625	36	96	8.82	212.
.625	48	144	8.82	423.
.625	60	144	8.82	529.
.750	36	96	10.6	254.
.750	48	144	10.6	508.
.750	60	144	10.6	635.
.875	36	96	12.4	296.
.875	48	144	12.4	593.
1.00	48	144	14.1	678.
1.00	60	144	14.1	847.
1.25	36	96	17.7	424.
1.25	48	144	17.7	849.
1.25	60	144	17.7	1059.
1.50	36	96	21.1	508.
1.50	48	144	21.1	1017.
1.50	60	144	21.1	1271.
1.75	36	96	24.7	593.
1.75	48	96	24.7	791.

ALUMINUM(CONT)

WEIGHT(LBS PER FT) SHEET, PLATE & TUBE

6061-T651 (FORMERLY 6061-T6)
ALUMINUM FLAT PLATE
MILL FINISH-OILED AND IDENTIFIED
(Continued)

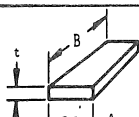

THICKNESS "t" INCHES	WIDTH "A" INCHES	LENGTH "B" INCHES	POUNDS SQUARE FOOT	POUNDS PER PLATE
1.75	48	144	24.7	1186.
2.00	36	96	28.2	678.
2.00	48	144	28.2	1356.
2.50	36	96	35.3	849.
2.50	48	144	35.3	1130.
2.50	48	144	35.3	1694.
3.00	36	96	42.4	1017.
3.00	48	96	42.4	1356.
3.055	36	96	43.9	1054.
3.50	48	96	49.4	1581.
3.50	48	144	49.4	2372.
4.00	48	96	56.5	1807.
4.00	48	144	56.5	2711.
5.00	48	96	70.6	2259.
5.00	48	144	70.6	3389.
6.00	48	72	84.7	2033.
6.00	48	144	84.7	4066.

7075-T6 ALCLAD ALUMINUM
FLAT SHEET
MILL FINISH
INTERLEAVED AND IDENTIFIED

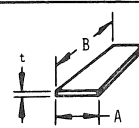

THICKNESS "t" INCHES	WIDTH "A" INCHES	LENGTH "B" INCHES	POUNDS SQUARE FOOT	POUNDS PER SHEET
.125	36	96	1.82	43.7
.190	36	96	2.76	66.2
.190	48	144	2.76	132.5

6061-T6 EXTRUDED ALUMINUM
TUBE
12 Foot Exact Lengths

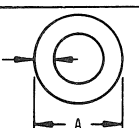

DIMENSION "A" INCHES	DIMENSION "t" INCHES	POUNDS PER FOOT	POUNDS 12' LENGTH
1-1/2	.125	.630	7.56
1-1/2	.250	1.15	13.8
2	.125	.870	10.4
2	.250	1.62	19.4
2-1/2	.125	1.10	13.2
2-1/2	.250	2.08	25.0
3	.125	1.33	16.0
3	.250	2.54	30.5

6061-T6 MECHANICAL TUBE
EXTRUDED
12 Foot Exact Lengths

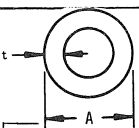

DIMENSION "A" INCHES	DIMENSION "t" INCHES	POUNDS PER FOOT	POUNDS 12' LENGTH
3-1/4	.500	5.08	61.0
3-1/2	.750	7.62	91.4
4	.750	9.01	108.
4-1/2	.750	10.4	125.
5	.750	11.8	142.
5	1.00	14.8	178.
5-1/2	1.00	16.6	199.
6	1.00	18.5	222.
7	1.00	22.2	266.
8	1.00	25.9	311.

6061-T6 DRAWN-ALUMINUM TUBE
12 Foot Lengths

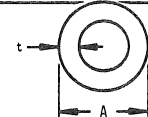

DIMENSION "A" INCHES	DIMENSION "t" INCHES	POUNDS PER FOOT	POUNDS 12' LENGTH
3/16	.035	.0197	.236
1/4	.035	.0278	.334
1/4	.044	.0364	.437
5/16	.035	.0359	.431
5/16	.058	.0550	.660
3/8	.035	.0440	.528
3/8	.049	.0590	.708
3/8	.065	.0740	.888
7/16	.035	.0520	.624
7/16	.049	.0700	.840
7/16	.065	.0890	1.07
1/2	.035	.0600	.720
1/2	.049	.0820	.984
1/2	.058	.0950	1.14
1/2	.065	.104	1.25
9/16	.035	.0680	.816
5/8	.035	.0760	.912
5/8	.049	.104	1.25
5/8	.058	.121	1.45
5/8	.065	.134	1.61
3/4	.035	.092	1.10
3/4	.049	.127	1.52
3/4	.058	.148	1.78
3/4	.065	.164	1.97
3/4	.083	.205	2.46
7/8	.035	.109	1.31
7/8	.058	.175	2.10
7/8	.065	.194	2.33
1	.035	.125	1.50
1	.049	.172	2.06
1	.058	.202	2.42
1	.065	.225	2.70
1	.083	.281	3.37
1-1/8	.035	.141	1.69
1-1/8	.058	.229	2.75
1-1/4	.035	.157	1.88
1-1/4	.049	.217	2.60
1-1/4	.058	.255	3.06
1-1/4	.065	.285	3.42
1-1/4	.083	.358	4.30
1-3/8	.058	.282	3.38
1-1/2	.035	.189	2.27
1-1/2	.065	.345	4.14
1-1/2	.083	.435	5.22
1-3/4	.058	.363	4.35
1-3/4	.083	.510	6.12
2	.049	.353	4.24
2	.065	.465	5.58
2	.083	.590	7.08
2-1/4	.065	.520	6.24
2-1/2	.065	.580	6.96
3	.065	.700	8.40

6063-T5 RECTANGULAR ALUMINUM TUBING
EXTRUDED - SHARP CORNERS
21'1" Exact Lengths

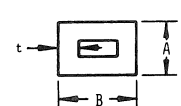

DIMENSION "A" INCHES	DIMENSION "B" INCHES	DIMENSION "t" INCHES	POUND PER FOOT	POUNDS 21' LENGTH
1/2"	1"	.125	.374	7.89
3/4"	1-1/2"	.125	.600	12.6
1"	1-1/2"	.125	.674	14.2
1"	2"	.125	.824	17.4
1-1/4"	2-1/2"	.125	1.050	22.1
1-1/2"	2"	.125	.974	20.5
1-3/4"	3"	.125	1.35	28.5
1-3/4"	3-1/2"	.125	1.50	31.6
1-3/4"	4"	.125	1.65	34.8
1-3/4"	5"	.125	1.95	41.1
2"	3"	.125	1.43	30.1
2"	5"	.125	2.03	42.8

6063-T5 SQUARE ALUMINUM TUBING
EXTRUDED - SHARP CORNERS
21'1" Lengths

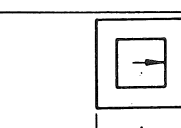

DIMENSION "A" INCHES	DIMENSION "t" INCHES	POUNDS PER FOOT	POUNDS 21' LENGTH
3/4	.125	.374	7.89
1	.125	.524	11.0
1-1/4	.125	.674	14.2
1-1/2	.125	.824	17.4
1-3/4	.125	.974	20.5
2	.125	1.12	23.6

BRASS

TABLE OF CONTENTS

SECTION 8

	PAGE(S)
WIRE	8-2
BAR	8-3
FOIL	8-3
STRIP	8-4
SHEET	8-4
TUBE	8-5
PINION GEAR STOCK	8-5
PINION WIRE	8-5
ASTM B16 SPECIFICATION	8-9 & 8-10
ASTM B36 SPECIFICATION	8-11
ASTM B121 SPECIFICATION	8-12
ASTM B134 SPECIFICATION	8-13
ASTM B135 SPECIFICATION	8-14 & 8-15
ASTM B453 SPECIFICATION	8-16
ASTM B248 (TOLERANCES)	12-10 & 12-11
ASTM B249 (TOLERANCES)	12-12 & 12-13
ASTM B250 (TOLERANCES)	12-14
ASTM B251 (TOLERANCES)	12-15
NOTES	8-6
CROSS REFERENCE INDEX	8-7 & 8-8
WEIGHT (LBS PER FT)	8-17 THRU 8-22

8

TEK STANDARDS PERTAINING TO MATERIALS

062-1702-00	Welding, Soldering & Brazing	D-100	Die Casting & Molding Standards
062-1703-00	Finishes, Glossary of Terms		
062-1713-00	Drafting, Aluminum Extrusions	H Series	Tooling Standards
062-1718-00	Finish Quality, Cosmetic		
062-2845-00	Mechanically Applied Finishes		
062-2848-00	Bend Allowance & Deduction	062-5818-01	Aluminum (M-150)
062-2850-00	Finish, Surface Texture	M-200	Brass
062-2854-00	Finishes, Chemical & Electromechanical	M-250	Copper
062-2856-00	Non-Additive Finishes for Brass, Copper & Copper Alloys	M-300	Copper-Beryllium
062-2860-00	Finishes, Anodized	M-350	Beryllium-Nickel
062-2863-00	Zinc Die Cast Finishes, Chromate Conversion Coatings	M-400	Phosphor-Bronze
062-2868-00	Finish, Etch Chromate & Lacquer (On Aluminum)	M-450	Steel
062-2868-01	Chromate Conversion Coating for Al Die Casting Alloy 3431	M-500	Stainless Steel
062-2871-00	Finish, Passivating	M-550	Magnetic Shielding Materials (Iron-Nickel & Nickel-Silver)
062-5818-00	General Information about Bulk Raw Materials	M-600	Copper-Nickel-Zinc

COST CODE

(CC COLUMN)

CODE	A	B	C	D	E	F	G	H	I	J	K	L	M	N	O
≈ VALUE with +	.75¢	2¢	3.75¢	6¢	10¢	18¢	35¢	60¢	\$1	\$2	\$3.75	\$6	\$10	\$18	\$35+
≈ VALUE no suffix	.5¢	1.5¢	3¢	5¢	8¢	15¢	25¢	50¢	75¢	\$1.50	\$3	\$5	\$8	\$15	\$25
≈ VALUE with -	.2¢	1.25¢	2.5¢	4.25¢	7¢	13¢	22¢	40¢	65¢	\$1.25	\$2.50	\$4.25	\$7	\$13	\$22

NOTE: Costs may vary from order to order due to order quantities, vendor, etc.

CATALOG WRITER: NORMA PETERSON, EXT. 2577.

BRASS (CONT)

WIRE

SIZE	ALLOY	TEMPER	SPECIFICATION*	TOLERANCE** (ASTM)	PART NUMBER	CC	OTHER
.008 x 1.060 +.000 -.010 x 12 ft Coil stock	C26000	One half Hard	ASTM B36	B248	251-0342-01		
.008 x 1.400	C26000	One half Hard	ASTM B36	B248	251-0342-02		
.010 x .625 x 12 ft long	C26000	One half Hard	ASTM B36	B248	258-0307-00	J+ 1b	
.0126 x .875 x 12 ft long	C26000	One half Hard	ASTM B36	B248	258-0366-00	J 1b	
.016 x .080 x 12 ft long	C26000	One half Hard	ASTM B36	B248	258-0487-00	M 1b	
.016 x .700 Coil stock	C26000	One half Hard	ASTM B36	B248	251-0315-04	J+ 1b	
.016 x .750 Coil stock	C26000	One half Hard	ASTM B36	B248	251-0315-05	J+ 1b	
.016 x 1.000 Coil stock	C26000	One half Hard	ASTM B36	B248	251-0315-06	J 1b	
.020 x .187 Coil stock	C26000	One half Hard	ASTM B36	B248	251-0316-05	K- 1b	
.020 x .874 Coil stock	C26000	One half Hard	ASTM B36	B248	251-0316-03	J 1b	
.020 x 1.000 Coil stock	C26000	One half Hard	ASTM B36	B248	251-0316-04	J+ 1b	
.0245 x 12 ft long	C26000	One half Hard	ASTM B36	B248	251-0430-00	I oz	
.025 ±.0013 sq x 12 ft long	C26000	One half Hard	ASTM B134	B250	258-0455-00	L- 1b	
.025 x .219 x 12 ft long	C26000	One half Hard	ASTM B36	B248	258-0337-00	J 1b	
.032 dia x 12 ft long	C26000	One half Hard	ASTM B134	B250	258-0318-00	A- 1b	Tinned finish
.032 x .687 Coil stock	C26000	One half Hard	ASTM B36	B248	251-0333-01	K 1b	
.032 x .687 Coil stock	C26000	One half Hard	ASTM B36	B248	251-0333-02	J+ 1b	
.032 x 1.125 Coil stock	C26000	One half Hard	ASTM B36	B248	251-0333-08	J 1b	
.032 x 7.250 Coil stock	C26000	One half Hard	ASTM B36	B248	251-0333-09	J 1b	
.040 x .144 ±.002 Coil stock	C26000	One half Hard	ASTM B36	B248	251-0317-01	L+ 1b	
.0403 dia x 12 ft long	C26000	One half Hard	ASTM B134	B250	258-0342-00	F+ 1b	
.045 ±.001 sq w/.005 corner radii .0595 ±.002 corner to corner Coil stock	C26000	One half Hard	ASTM B134	B250	251-0445-00	G oz	
.048 +.001 -.000 dia x 12 ft long	C26000	One half Hard	ASTM B134	B250	258-0368-00	I- oz	
.051 dia Coil stock	C26000	Spring	ASTM B134	B250	258-0430-00	A- 1b	
.062 ±.0008 dia Coil stock	C26000	One qtr Hard	ASTM B134	B250	251-0494-00	L- 1b	
.0625 dia ±.0008 x 12 ft long	C36000	One half Hard	ASTM B16	B249, B250	251-0391-00	F- oz	
.064 x .250 x 12 ft long	C26000	One half Hard	ASTM B36	B248	258-0359-00	K 1b	
.072 dia x 6 ft long	C36000	Full Hard	ASTM B16	B249, B250	258-0499-00	K 1b	
.072 ±.0008 dia x 12 ft long	C26000	Spring	ASTM B134	B250	251-0350-00	M- 1b	
.094 hex x 12 ft long	C36000	One half Hard	ASTM B16	B249, B250	258-0443-00	J+ 1b	
.094 dia x 12 ft long	C36000	One half Hard	ASTM B16	B249, B250	251-0399-00	E+ oz	
.125 dia x 12 ft long	C36000	One half Hard	ASTM B16	B249, B250	251-0306-00	E oz	
.125 hex x 12 ft long	C36000	One half Hard	ASTM B16	B249, B250	258-0356-00	J+ 1b	
.156 dia x 12 ft long	C36000	One half Hard	ASTM B16	B249, B250	251-0307-00	J 1b	
.156 hex x 12 ft long	C36000	One half Hard	ASTM B16	B249, B250	251-0382-00	J 1b	
.156 dia x 12 ft long	C34200	One half Hard	ASTM B121	B248	251-0453-00	J 1b	
.188 dia x 12 ft long	C34200	One half Hard	ASTM B121	B248	251-0308-00	J- 1b	
.188 hex x 12 ft long	C36000	One half Hard	ASTM B16	B249, B250	251-0301-00	J- 1b	
.219 dia x 12 ft long	C36000	One half Hard	ASTM B16	B249, B250	251-0343-00	J- 1b	
.219 hex x 12 ft long	C36000	One half Hard	ASTM B16	B249, B250	258-0432-00	J+ 1b	
.219 dia x 12 ft long	C34200	One half Hard	ASTM B121	B248	251-0454-00	J- 1b	
.2438 +.0003 -.0002 dia x 5 or 6 ft long	C36000	One half Hard	ASTM B16	B249, B250	251-0485-00	K- 1b	
.250 dia x 12 ft long	C36000	One half Hard	ASTM B16	B249, B250	251-0309-00	J- 1b	
.250 sq x 12 ft long	C36000	One half Hard	ASTM B16	B249, B250	258-0482-00	J+ 1b	
.250 hex x 12 ft long	C36000	One half Hard	ASTM B16	B249, B250	251-0345-00	J- 1b	
.250 dia x 12 ft long	C34200	One qtr Hard	ASTM B121	B248	258-0377-00	J- 1b	
.281 dia x 12 ft long	C36000	One half Hard	ASTM B16	B249, B250	251-0331-00	J- 1b	
.281 hex x 12 ft long	C36000	One half Hard	ASTM B16	B249, B250	251-0380-00	H ft	
.281 dia x 12 ft long	C34200	One qtr Hard	ASTM B121	B248	258-0365-00	J- 1b	
.281 sq x 12 ft long	C35300	One half Hard	ASTM B121	B248	258-0322-00	J- 1b	
.312 hex x 12 ft long	C36000	One half Hard	ASTM B16	B248, B250	251-0373-00	J- 1b	
.312 dia x 12 ft long	C36000	One half Hard	ASTM B16	B249, B250	251-0328-00	J- 1b	
.312 sq x 12 ft long	C36000	One half Hard	ASTM B16	B249, B250	258-0360-00	J- 1b	
.344 dia x 12 ft long	C36000	One half Hard	ASTM B16	B249, B250	258-0358-00	I+ 1b	
.344 hex . 12 ft long	C36000	One half Hard	ASTM B16	B249, B250	251-0446-00	J- 1b	

* Mechanical properties can be found on pages 8-9 thru 8-16.
 ** Tolerances can be found on pages 12-12 thru 12-23.

BRASS (CONT)

BAR

SIZE	ALLOY	TEMPER	SPECIFICATION*	TOLERANCE** (ASTM)	PART NUMBER	CC	OTHER
.125 x .375 x 12 ft long	C36000	One half Hard	ASTM B16	B249, B250	251-0314-00	J+ 1b	
.187 x .500 Coil stock	C36000	One half Hard	ASTM B16	B249, B250	251-3054-00	J+ 1b	
.250 x .500 x 12 ft long	C36000	One half Hard	ASTM B16	B249, B250	258-0344-00	K- 1b	
.250 x 1.750 x 12 ft long	C36000	One half Hard	ASTM B16	B249, B250	258-0376-00	J+ 1b	
.312 x .625 x 12 ft long	C36000	One half Hard	ASTM B16	B249, B250	258-0450-00	J- 1b	
.312 x .875 x 12 ft long	C36000	One half Hard	ASTM B16	B249, B250	258-0379-00	J+ 1b	
.375 dia x 12 ft long	C34200	One qtr Hard	ASTM B121	B248	251-0457-00	I+ 1b	
.375 dia x 12 ft long	C36000	One half Hard	ASTM B16	B249, B250	251-0310-00	I+ 1b	
.375 ±.0015 hex x 12 ft long	C36000	One half Hard	ASTM B16	B249, B250	251-0476-00	I+ 1b	
.375 hex x 12 ft long	C36000	One half Hard	ASTM B16	B249, B250	251-0302-00	I+ 1b	
.375 x .750 x 12 ft long	C36000	One half Hard	ASTM B16	B249, B250	258-0407-00	J- 1b	
.375 x 1.000 x 12 ft long	C36000	One half Hard	ASTM B16	B249, B250	258-0449-00	J+ 1b	
.438 dia x 12 ft long	C34200	One half Hard	ASTM B121	B249, B250	251-0339-00	I+ 1b	
.438 hex x 12 ft long	C36000	One half Hard	ASTM B16	B249, B250	251-0303-00	I+ 1b	
.500 dia x 12 ft long	C36000	One half Hard	ASTM B16	B249, B250	251-0311-00	I+ 1b	
.500 hex x 12 ft long	C36000	One half Hard	ASTM B16	B249, B250	251-0304-00	I+ 1b	
.500 x .625 x 12 ft long	C36000	One half Hard	ASTM B16	B249, B250	258-0398-00	J+ 1b	
.500 x 3.000 x 12 ft long	C33000	One half Hard	ASTM B16	B249, B250	258-0428-00	J 1b	
.562 dia x 12 ft long	C36000	One half Hard	ASTM B16	B249, B250	251-0433-00	I+ 1b	
.562 hex x 12 ft long	C36000	One half Hard	ASTM B16	B249, B250	251-0305-00	I+ 1b	
.624 +.000 -.003 dia x 12 ft long	C36000	One half Hard	ASTM B16	B249, B250	251-0312-00	I+ 1b	
.625 hex x 12 ft long	C36000	One half Hard	ASTM B16	B249, B250	251-0441-00	H- 1b	
.688 dia x 12 ft long	C36000	One half Hard	ASTM B16	B249, B250	251-0403-00	I+ 1b	
.719 dia x 12 ft long	C36000	One half Hard	ASTM B16	B249, B250	251-0414-00	I+ 1b	
.750 dia x 12 ft long	C34200	One half Hard	ASTM B121	B249, B250	251-0495-00	I 1b	
.750 dia x 12 ft long	C36000	One half Hard	ASTM B16	B249, B250	251-0313-00	I+ 1b	
.750 hex x 12 ft long	C36000	One half Hard	ASTM B16	B249, B250	258-0306-00	I+ 1b	
.812 dia x 12 ft long	C36000	One half Hard	ASTM B16	B249, B250	251-0426-00	J- 1b	
.875 dia x 12 ft long	C36000	One half Hard	ASTM B16	B249, B250	251-0482-00	I+ 1b	
1.000 x 1.500 x 12 ft long	C36000	One half Hard	ASTM B16	B249, B250	258-0409-00	J- 1b	
1.000 ±.0025 dia x 12 ft long	C36000	One half Hard	ASTM B16	B249, B250	258-0500-00	I+ 1b	
1.062 dia x 12 ft long	C36000	One half Hard	ASTM B16	B249, B250	251-0394-00	I+ 1b	
1.250 dia x 12 ft long	C36000	One half Hard	ASTM B16	B249, B250	251-0491-00	I+ 1b	
1.375 dia x 12 ft long	C36000	One half Hard	ASTM B16	B249, B250	258-0301-00	I+ 1b	
1.625 dia x 12 ft long	C36000	One half Hard	ASTM B16	B249, B250	251-0486-00	J- 1b	
2.000 dia x 12 ft long	C36000	One half Hard	ASTM B16	B249, B250	258-0303-00		
2.000 dia x 12 ft long	C36000	One half Hard	ASTM B16	B249, B250	258-0466-00	I 1b	
2.250 dia x 12 ft long	C36000	One half Hard	ASTM B16	B249, B250	258-0304-00	I 1b	

8

FOIL

SIZE	ALLOY	TEMPER	SPECIFICATION*	TOLERANCE** (ASTM)	PART NUMBER	CC	OTHER
.003 x 6.000 in wide	C26000	One half Hard	ASTM B36	B248	251-0499-00	F+ oz	
.004 x 6.000 or 12.000 in wide	C26000	One half Hard	ASTM B36	B248	251-0496-00	F oz	

COST CODE

(CC COLUMN)

CODE	A	B	C	D	E	F	G	H	I	J	K	L	M	N	O
≈ VALUE with +	.75¢	2¢	3.75¢	6¢	10¢	18¢	35¢	60¢	\$1	\$2	\$3.75	\$6	\$10	\$18	\$35+
≈ VALUE no suffix	.5¢	1.5¢	3¢	5¢	8¢	15¢	25¢	50¢	75¢	\$1.50	\$3	\$5	\$8	\$15	\$25
≈ VALUE with -	.2¢	1.25¢	2.5¢	4.25¢	7¢	13¢	22¢	40¢	65¢	\$1.25	\$2.50	\$4.25	\$7	\$13	\$22

NOTE: Costs may vary from order to order due to order quantities, vendor, etc.

* Mechanical properties can be found on pages 8-9 thru 8-16.

** Tolerances can be found on pages 12-12 thru 12-23.

BRASS (CONT)

STRIP

SIZE	ALLOY	TEMPER	SPECIFICATION*	TOLERANCE** (ASTM)	PART NUMBER	CC	OTHER
.006 x 6.000 Coil stock	C26000	One half Hard	ASTM B36	B248	251-0440-00	M+ 1b	
.008 x 12.000 Coil stock	C26000	One half Hard	ASTM B36	B248	258-0520-00	G- oz	
.010 x 1.500 Coil stock	C26000	One half Hard	ASTM B36	B248	258-0307-03	J+ 1b	
.010 x 1.625 Coil stock	C26000	One half Hard	ASTM B36	B248	258-0307-05	J+ 1b	
.010 x 2.000 Coil stock	C26000	One half Hard	ASTM B36	B248	258-0307-06	J 1b	
.010 x 2.250 Coil stock	C26000	One half Hard	ASTM B36	B248	258-0307-04	J 1b	
.010 x 3.000 Coil stock	C26000	One half Hard	ASTM B36	B248	258-0307-07	J+ 1b	
.010 x 4.250 Coil stock	C26000	One half Hard	ASTM B36	B248	258-0307-01	K 1b	
.010 x 6.000 Coil stock	C26000	One half Hard	ASTM B36	B248	258-0307-02	J 1b	
.016 x 1.250 Coil stock	C26000	One half Hard	ASTM B36	B248	251-0315-01	J 1b	
.016 x 1.625 Coil stock	C26000	One half Hard	ASTM B36	B248	251-0315-03	J 1b	
.016 x 3.250 Coil stock	C26000	One half Hard	ASTM B36	B248	251-0315-02	J 1b	
.016 x 3.500 Coil stock	C26000	One half Hard	ASTM B36	B248	251-0315-07	J+ 1b	
.020 x 1.500 Coil stock	C26000	One half Hard	ASTM B36	B248	251-0316-01	J 1b	
.020 x 1.670 Coil stock	C26000	One half Hard	ASTM B36	B248	258-0509-00	J+ 1b	
.020 x 3.000 Coil stock	C26000	Soft	ASTM B36	B248	251-0489-00	K+ 1b	
.020 x 4.000 Coil stock	C26000	One half Hard	ASTM B36	B248	251-0316-02	J 1b	
.025 x 2.750 Coil stock	C26000	One half Hard	ASTM B36	B248	258-0337-04	J- 1b	
.032 x 1.750 Coil stock	C26000	One half Hard	ASTM B36	B248	251-0333-03	J 1b	
.032 x 2.000 Coil stock	C26000	One half Hard	ASTM B36	B248	251-0333-06	J 1b	
.032 x 2.250 Coil stock	C26000	One half Hard	ASTM B36	B248	251-0333-10	J+ 1b	
.032 x 2.500 Coil stock	C26000	One half Hard	ASTM B36	B248	258-0519-00	J- 1b	
.032 x 6.000 x 96 in long	C26000	One half Hard	ASTM B36	B248	251-0333-07	J- 1b	
.032 x 12.000 x 96 in long	C26000	One qtr Hard	ASTM B36	B248	258-0445-00	J+ 1b	
.040 x 7.250 Coil stock	C26000	One half Hard	ASTM B36	B248	251-0317-02	J 1b	

SHEET

SIZE	ALLOY	TEMPER	SPECIFICATION*	TOLERANCE** (ASTM)	PART NUMBER	CC	OTHER
.016 x 24.000 x 96 in long	C26000	One half Hard	ASTM B36	B248	251-0315-00	J+ 1b	
.020 x 24.000 x 96 in long	C26000	One half Hard	ASTM B36	B248	251-0316-00	J+ 1b	
.025 x 24.000 x 96 in long	C26000	One half Hard	ASTM B36	B248	258-0337-03	J+ 1b	
.032 x 24.000 x 96 in long	C26000	One half Hard	ASTM B36	B248	251-0333-00	J+ 1b	
.040 x 24.000 x 96 in long	C26000	One half Hard	ASTM B36	B248	251-0317-00	J+ 1b	
.051 x 24.000 x 96 in long	C26000	One half Hard	ASTM B36	B248	251-0318-00	J+ 1b	
.064 ±.003 x 24.000 x 96 in long	C26000	One half Hard	ASTM B36	B248	251-0363-00	J- 1b	
.090 x 24.000 x 96 in long	C26000	One half Hard	ASTM B36	B248	251-0413-00	J+ 1b	
.125 x 24.000 x 96 in long	C26000	One half Hard	ASTM B36	B248	258-0408-00	J+ 1b	

COST CODE (CC COLUMN)

CODE	A	B	C	D	E	F	G	H	I	J	K	L	M	N	O
≈ VALUE with +	.75¢	2¢	3.75¢	6¢	10¢	18¢	35¢	60¢	\$1	\$2	\$3.75	\$6	\$10	\$18	\$35+
≈ VALUE no suffix	.5¢	1.5¢	3¢	5¢	8¢	15¢	25¢	50¢	75¢	\$1.50	\$3	\$5	\$8	\$15	\$25
≈ VALUE with -	.2¢	1.25¢	2.5¢	4.25¢	7¢	13¢	22¢	40¢	65¢	\$1.25	\$2.50	\$4.25	\$7	\$13	\$22

NOTE: Costs may vary from order to order due to order quantities, vendor, etc.

* Mechanical properties can be found on pages 8-9 thru 8-16.
 ** Tolerances can be found on pages 12-12 thru 12-23.

BRASS (CONT)

TUBE

SIZE	ALLOY	TEMPER	SPECIFICATION*	TOLERANCE** (ASTM)	PART NUMBER	CC	OTHER
.0625 OD x .042 ID x 12 ft long	C26000	Hard drawn	ASTM B135	B251	251-0393-00	N+ 1b	
.065 +.002 -.000 OD x .030 ID x 12 ft long	C26000	Light annealed	ASTM B135	B251	251-0479-00	H+ ft	
.094 ±.0005 OD x .073 ±.002 ID x 12 ft long	C26000	Drawn	ASTM B135	B251	258-0426-00	N- 1b	
.125 OD x .010 wall x 12 ft long	C26000	Hard drawn	ASTM B135	B251	251-0423-00	M 1b	
.125 OD x .025 wall x 12 ft long	C26000	Hard drawn	ASTM B135	B251	251-0351-00	N- 1b	
.155 +.0006 -.0012 OD x .086 ID x 12 ft long	C26000	Hard drawn	ASTM B135	B251	258-0489-00	I ft	
.156 ±.003 OD x .132 ID x 12 ft long	C26000	Hard drawn	ASTM B135	B251	258-0317-00	G+ ft	
.1875 ±.001 OD x .130 +.002 -.000 ID x 12 ft lg	C26000	Hard drawn	ASTM B135	B251	251-0437-00	B+ in	
.189 +.002 -.000 OD x .157 +.0010 -.0005 ID x 12 ft long	C26000	Hard drawn	ASTM B135	B251	258-0309-00	F+ ft	
.248 OD x .188 ID	C26000	Hard drawn	ASTM B135	B251	258-0505-00	G ft	
.248 +.000 -.001 OD x .132 ID x 12 ft long	C26000	Hard drawn	ASTM B135	B251	251-0389-00	K 1b	
.248 +.000 -.001 OD x .148 x.003 ID x 12 ft lg	C26000	Hard drawn	ASTM B135	B251	251-0492-00	G+ ft	
.250 OD x .035 wall x 12 ft long	C33000	Hard drawn	ASTM B135	B251	251-0319-00	L- 1b	
.250 OD x .065 wall x 12 ft long	C26000	Hard drawn	ASTM B135	B251	251-0368-00	K- 1b	
.281 OD x .261 ID x 12 ft long	C26000	Drawn	ASTM B135	B251	258-0521-00	N- 1b	
.281 ±.002 OD x .157 ±.002 ID x 12 ft long	C33200	Hard drawn	ASTM B135	B251	258-0412-00	L+ 1b	
.312 OD x .049 wall x 12 ft long	C33000	Hard drawn	ASTM B135	B251	258-0413-00	H- ft	
.319 +.000 -.002 ID x .018 wall x 8 to 12 ft lg	C33000	Hard drawn	ASTM B135	B251	258-0380-00	K+ 1b	
.319 +.000 -.002 ID x .028 wall x 12 ft long	C33000	Hard drawn	ASTM B135	B251	251-0402-00	J- 1b	
.344 ±.001 OD x .312 ID x 7 to 14 ft long	C26000	Drawn	ASTM B135	B251	258-0321-00	H+ ft	
.375 OD x .028 wall x 12 ft long	C26000	Hard drawn	ASTM B135	B251	251-0424-00	J+ 1b	
.375 OD x .250 ID x 12 ft long	C26000	Hard drawn	ASTM B135	B251	251-0358-00	L 1b	
.438 OD x .065 wall x 12 ft long	C26000	Hard drawn	ASTM B135	B251	251-0332-00	J+ 1b	
.500 OD x .032 wall x 12 ft long	C33000	Hard drawn	ASTM B135	B251	258-0389-00	K 1b	
.561 +.0005 -.003 OD x .500 +.002 -.000 ID x 12 ft long	C26000	Hard drawn	ASTM B135	B251	251-0459-00	J ft	
.562 dia x .065 wall x 12 ft long	C26000	Hard drawn	ASTM B135	B251	258-0387-00	M- 1b	
.624 +.000 -.003 OD x .065 wall x 12 ft long	C26000	Hard drawn	ASTM B135	B251	251-0404-00	L 1b	Plating quality finish
.624 +.000 -.003 OD x .562 +.001 ID x 12 ft lg	C26000	Hard drawn	ASTM B135	B251	251-0484-00	L 1b	
.625 OD x .566 x .005 -.000 ID x 12 ft long	C26000	Hard drawn	ASTM B135	B251	251-0428-00	O- 1b	CS Status
.625 OD x .375 ID	C33000	Hard drawn	ASTM B135	B251	258-0511-00	K 1b	
.688 x .028 wall x 12 ft long	C26000	Hard drawn	ASTM B135	B251	251-0337-00	K- 1b	
.750 OD x .028 wall x 12 ft long	C26000	Hard drawn	ASTM B135	B251	251-0321-00	J+ 1b	
.750 OD x .125 wall x 12 ft long	C33000	Hard drawn	ASTM B135	B251	251-0323-00	I 1b	
.875 OD x .028 wall x 12 ft long	C26000	Hard drawn	ASTM B135	B251	251-0427-00	J+ 1b	CS Status
.875 OD x .750 ID x 12 ft long	C33000	Hard drawn	ASTM B135	B251	251-0480-00	K+ 1b	
1.500 OD x .125 wall x 12 ft long	C26000	Hard drawn	ASTM B135	B251	258-0305-00		CS Status
2.000 OD x .083 wall x 12 ft long	C26000	Hard drawn	ASTM B135	B251	251-0435-00	I+ 1b	CS Status

8

PINION GEAR STOCK

251-0405-00, 6 Teeth, 32 Pitch
 251-0823-00, 16 Teeth, 48 Pitch
 258-0431-00, 18 Teeth, 64 Pitch

CC:
 J-/Ft
 M /Ft
 M /Ft

PINION WIRE

258-0523-00, 16 Teeth, 32 DP, 14.5 Deg., Brass, 6 to 9 Ft CC: L /Ft

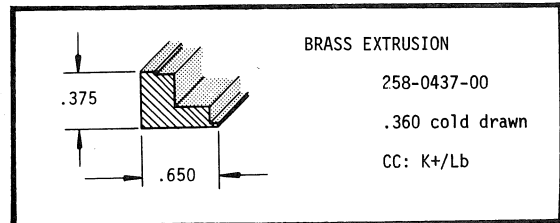

* Mechanical properties can be found on pages 8-9 - 8-16.
 ** Tolerances can be found on pages 12-12 thru 12-23.

NOTES

8

COST CODE

(CC COLUMN)

CODE	≈ VALUE with -	≈ VALUE no suffix	≈ VALUE with +
A	.2¢	.5¢	.75¢
B	1.25¢	1.5¢	2¢
C	2.5¢	3¢	3.75¢
D	4.25¢	5¢	6¢
E	7¢	8¢	10¢
F	13¢	15¢	18¢
G	22¢	25¢	35¢
H	40¢	50¢	60¢
I	65¢	75¢	\$1
J	\$1.25	\$1.50	\$2
K	\$2.50	\$3	\$3.75
L	\$4.25	\$5	\$6
M	\$7	\$8	\$10
N	\$13	\$15	\$18
O	\$22	\$25	\$35+

NOTE: Costs may vary from order to order
due to order quantities, vendor, etc.

CROSS REFERENCE INDEX

BRASS

PART NUMBER	DESCRIPTION	SIZE	PAGE NO.	STATUS§§	PART NUMBER	DESCRIPTION	SIZE	PAGE NO.	STATUS§§
251-0301-00	Wire	.188 hex	8-2	CR	251-0424-00	Tube	.375 OD x .028 wall	8-5	CR
251-0302-00	Bar	.375 hex	8-3	CR	251-0426-00	Bar	.812 dia	8-3	CS
251-0303-00	Bar	.438 hex	8-3	CR	251-0427-00	Tube	.875 OD x .028 wall	8-5	CS
251-0304-00	Bar	.500 hex	8-3	CR	251-0428-00	Tube	.625 OD x .566 ID	8-5	CS
251-0305-00	Bar	.562 hex	8-3	CR	251-0430-00	Wire	.0245 dia	8-2	CS
251-0306-00	Wire	.125 dia	8-2	CR	251-0433-00	Bar	.562 dia	8-3	CR
251-0307-00	Wire	.156 dia	8-2	CR	251-0435-00	Tube	2.000 OD x .083 wall	8-5	CS
251-0308-00	Wire	.188 dia	8-2	CR	251-0437-00	Tube	.1875 OD x .130 ID	8-5	CR
251-0309-00	Wire	.250 dia	8-2	CR	251-0440-00	Strip	.006 x 6.000	8-4	CR
251-0310-00	Bar	.375 dia	8-3	CR	251-0441-00	Bar	.625 hex	8-3	CS
251-0311-00	Bar	.500 dia	8-3	CR	251-0445-00	Wire	.045 sq	8-2	CR
251-0312-00	Bar	.624 dia	8-3	CR	251-0446-00	Wire	.344 hex	8-2	CR
251-0313-00	Bar	.750 dia	8-3	CR	251-0453-00	Wire	.156 dia	8-2	CR
251-0314-00	Bar	.125 x .375	8-3	CR	251-0454-00	Wire	.219 dia	8-2	CR
251-0315-00	Sheet	.016 x 24.000	8-4	CR	251-0457-00	Bar	.375 dia	8-3	CR
251-0315-01	Strip	.016 x 1.250	8-4	CR	251-0459-00	Tube	.561 OD x .500 ID	8-5	OB
251-0315-02	Strip	.016 x 3.250	8-4	CR	251-0467-00	Tube	.624 OD x .557 ID		OB
251-0315-03	Strip	.016 x 1.625	8-4	CR	251-0473-00	Tube	.625 OD x .125 wall		NP
251-0315-04	Wire	.016 x .700	8-2	CR	251-0476-00	Bar	.375 hex	8-3	CR
251-0315-05	Wire	.016 x .750	8-2	CR	251-0479-00	Tube	.065 OD x .030 ID	8-5	CR
251-0315-06	Wire	.016 x 1.000	8-2	CS	251-0480-00	Tube	.875 OD x .750 ID	8-5	CS
251-0315-07	Strip	.016 x 3.500	8-4	CR	251-0481-00	Strip	.032 x 12.000		NP
251-0316-00	Sheet	.020 x 24.000	8-4	CR	251-0482-00	Bar	.875 dia	8-3	CR
251-0316-01	Strip	.020 x 1.500	8-4	CR	251-0484-00	Tube	.624 OD x .562 ID	8-5	CR
251-0316-02	Strip	.020 x 4.000	8-4	CS	251-0485-00	Wire	.2438 dia	8-2	CR
251-0316-03	Wire	.020 x .874	8-2	CR	251-0486-00	Bar	1.625 dia	8-3	CR
251-0316-04	Wire	.020 x 1.000	8-2	CR	251-0489-00	Strip	.020 x 3.000	8-4	CS
251-0316-05	Wire	.020 x .187	8-2	CS	251-0489-01	Strip	.020 x 6.000		DL
251-0317-00	Sheet	.040 x 24.000	8-4	CR	251-0491-00	Bar	1.250 dia	8-3	CR
251-0317-01	Wire	.040 x .144	8-2	CR	251-0492-00	Tube	.248 OD x .148 ID	8-5	CR
251-0317-02	Strip	.040 x 7.250	8-4	CR	251-0494-00	Wire	.062 dia	8-2	CR
251-0318-00	Sheet	.051 x 24.000	8-4	CR	251-0495-00	Bar	.750 dia	8-3	CR
251-0319-00	Tube	.250 OD x .035 wall	8-5	CR	251-0496-00	Foil	.004 x 6.000 or 12.000	8-3	CR
251-0321-00	Tube	.750 OD x .028 wall	8-5	CS	251-0499-00	Foil	.003 x 6.000	8-3	CR
251-0323-00	Tube	.750 OD x .125 wall	8-5	CR	251-0522-00	Wire	.025 dia		NP
251-0326-00	Wire Cloth	.360 x .125		DL	251-0823-00	Gearstock	16 teeth, 48 pitch	8-5	CR
251-0328-00	Wire	.312 dia	8-2	CR	251-3054-00	Bar	.187 x .500	8-3	CR
251-0331-00	Wire	.281 dia	8-2	CR	258-0301-00	Bar	1.375 dia	8-3	CR
251-0332-00	Tube	.438 OD x .065 wall	8-5	CS	258-0303-00	Bar	2.000 dia	8-3	OB
251-0333-00	Sheet	.032 x 24.000	8-4	CR	258-0304-00	Bar	2.250 dia	8-3	CR
251-0333-01	Wire	.032 x .687	8-2	CR	258-0305-00	Tube	1.500 OD x .125 wall	8-5	OB
251-0333-02	Wire	.032 x .687	8-2	CR	258-0306-00	Bar	.750 hex	8-3	CR
251-0333-03	Strip	.032 x 1.750	8-4	CR	258-0307-00	Wire	.010 x .625	8-2	CR
251-0333-06	Strip	.032 x 2.000	8-4	CR	258-0307-01	Strip	.010 x 4.250	8-4	CS
251-0333-07	Strip	.032 x 6.000	8-4	CS	258-0307-02	Strip	.010 x 6.000	8-4	CR
251-0333-08	Wire	.032 x 1.125	8-2	CR	258-0307-03	Strip	.010 x 1.500	8-4	CR
251-0333-09	Wire	.032 x 7.250	8-2	CR	258-0307-04	Strip	.010 x 2.250	8-4	CR
251-0333-10	Strip	.032 x 2.250	8-4	CR	258-0307-05	Strip	.010 x 1.625	8-4	CR
251-0337-00	Tube	.688 x .028 wall	8-5	CS	258-0307-06	Strip	.010 x 2.000	8-4	OT
251-0339-00	Bar	.438 dia	8-3	CR	258-0307-07	Strip	.010 x 3.000	8-4	CR
251-0342-00	Sheet	.008 x 24.000		NP	258-0309-00	Tube	.189 OD x .157 ID	8-5	CR
251-0342-01	Wire	.008 x 1.060	8-2	OB	258-0317-00	Tube	.156 OD x .132 ID	8-5	CR
251-0342-02	Wire	.008 x 1.400	8-2	OB	258-0318-00	Wire	.032 dia	8-2	CR
251-0343-00	Wire	.219 dia	8-2	CR	258-0321-00	Tube	.344 OD x .312 ID	8-5	CR
251-0345-00	Wire	.250 hex	8-2	CR	258-0322-00	Wire	.281 sq	8-2	CR
251-0350-00	Wire	.072 dia	8-2	CS	258-0337-00	Wire	.025 x .219	8-2	OB
251-0351-00	Tube	.250 OD x .025 wall	8-5	CR	258-0337-01	Wire	.025 x .437		OB
251-0358-00	Tube	.375 OD x .250 ID	8-5	CR	258-0337-02	Wire	.025 x .750		OB
251-0363-00	Sheet	.064 x 24.000	8-4	CR	258-0337-03	Sheet	.025 x 24.000	8-4	CR
251-0368-00	Tube	.250 OD x .065 wall	8-5	CR	258-0337-04	Strip	.025 x 2.750	8-4	CR
251-0373-00	Wire	.132 hex	8-2	CR	258-0342-00	Wire	.0403 dia	8-2	CR
251-0380-00	Wire	.281 hex	8-2	CR	258-0344-00	Bar	.250 x .500	8-3	CR
251-0382-00	Wire	.156 hex	8-2	CR	258-0350-00	Tube	.500 dia x .020 wall		CS
251-0389-00	Tube	.248 OD x .132 ID	8-5	CR	258-0351-00	Wire	.250 dia		NP
251-0391-00	Wire	.0625 dia	8-2	CR	258-0356-00	Wire	.125 hex	8-2	CR
251-0393-00	Tube	.0625 OD x .042 ID	8-5	CR	258-0358-00	Wire	.344 dia	8-2	CR
251-0394-00	Bar	1.062 dia	8-3	CR	258-0359-00	Wire	.064 x .250	8-2	CS
251-0399-00	Wire	.094 dia	8-2	CR	258-0360-00	Wire	.312 sq	8-2	CR
251-0402-00	Tube	.319 ID x .028 wall	8-5	OB	258-0365-00	Wire	.281 dia	8-2	CR
251-0403-00	Bar	.688 dia	8-3	CR	258-0366-00	Wire	.0126 x .875	8-2	CR
251-0404-00	Tube	.624 OD x .065 wall	8-5	CR	258-0368-00	Wire	.048 dia	8-2	CR
251-0405-00	Gearstock	6 teeth, 32 pitch	8-5	CS	258-0376-00	Bar	.250 x 1.750	8-3	CR
251-0413-00	Sheet	.090 x 24.000	8-4	CR	258-0377-00	Wire	.250 dia	8-2	CR
251-0414-00	Bar	.719 dia	8-3	CR	258-0379-00	Bar	.312 x .875	8-3	CR
251-0423-00	Tube	.105 ID x .010 wall	8-5	CR	258-0380-00	Tube	.319 ID x .018 wall	8-5	CR

CROSS REFERENCE INDEX (CONT)

BRASS

PART NUMBER	DESCRIPTION	SIZE	PAGE NO.	STATUS§§
258-0387-00	Tube	.562 dia x .065 wall	8-5	CR
258-0389-00	Tube	.500 OD x .032 wall	8-5	OB
258-0398-00	Bar	.500 x .625	8-3	CR
258-0406-00	Tube	5.000 dia x .250 wall		CS
258-0407-00	Bar	.375 x .750	8-3	CR
258-0408-00	Sheet	.125 x 24.000	8-4	CR
258-0409-00	Bar	1.000 x 1.500	8-3	CR
258-0412-00	Tube	.281 OD x .157 ID	8-5	CR
258-0413-00	Tube	.312 OD x .049 wall	8-5	CR
258-0426-00	Tube	.094 OD x .073 ID	8-5	CR
258-0428-00	Bar	.500 x 3.000	8-3	CR
258-0430-00	Wire	.051 dia	8-2	CR
258-0431-00	Gearstock	18 teeth, 64 pitch	8-5	CR
258-0432-00	Wire	.219 hex	8-2	CR
258-0437-00	Extrusion	.375 x .650	8-5	CR
258-0443-00	Wire	.094 hex	8-2	CR
258-0445-00	Strip	.032 x 12.000	8-4	CR
258-0449-00	Bar	.375 x 1.000	8-3	CR
258-0450-00	Bar	.312 x .625	8-3	CR
258-0455-00	Wire	.025 sq	8-2	CR
258-0466-00	Bar	2.000 dia	8-3	CR
258-0482-00	Wire	.250 sq	8-2	CR
258-0486-00	Bar	.750 x 2.000		DL
258-0487-00	Wire	.016 x .080	8-2	CS
258-0489-00	Tube	.155 OD x .086 ID	8-5	CR
258-0499-00	Wire	.072 dia	8-2	CR
258-0500-00	Bar	1.000 dia	8-3	CR
258-0505-00	Tube	.248 OD x .188 ID	8-5	CR
258-0509-00	Strip	.020 x 1.670	8-4	CR
258-0511-00	Tube	.625 OD x .375 ID	8-5	CR
258-0519-00	Strip	.032 x 2.500	8-4	CR
258-0520-00	Strip	.008 x 12.000	8-4	CR
258-0521-00	Tube	.281 OD x .261 ID	8-5	CR
258-0523-00	Gearstock	16 teeth	8-5	CR

§§ STATUS CODES

CR	Current Production
EN	Engineering
PP	Pre-Production
CS	Customer Service
NP	Non-Production
DL	Deleted
OB	Obsolete Instrument
CM	Custom Mod Instrument
DS	Digital Systems
OT	Obsoluscent Instrument
MP	Modified Part
LR	Last Supply Current
LS	Last Supply Customer Service
VN	Vendor
TC	Tequipment Current Production
IN	International
SC	Sony/Tek Current Production

THE STATUS IN THIS CATALOG WAS CORRECT AT THE TIME IT WAS PUBLISHED, BUT IT IS SUBJECT TO CHANGE.

§ TO USE A PART WITH THIS STATUS ON A NEW INSTRUMENT REQUIRES THAT A NEW PURCHASED PART INITIATION FORM (PPIF) BE INITIATED.

(A GLOSSARY OF TERMS FOR THESE STATUS CODES CAN BE FOUND ON PAGE 0-10).

BRASS (CONT)

†† ASTM B16

TENSILE REQUIREMENTS

COPPER ALLOY NO. C36000

ROUNDS, HEXAGONS, OCTAGONS

TEMPER		DIAMETER	MINIMUM TENSILE STRENGTH + KSI	MINIMUM YIELD STRENGTH + KSI	ELONGATION IN 4 X DIA. MIN %
NEW DESIGNATION (ASTM B601)	FORMER DESIGNATION				
060	SOFT	1 inch and under	48	20	15 %
		over 1 in to 2 in	44	18	20 %
		over 2 inches	40	15	25 %
H02	HALF-HARD	.50 in & under	57	25	7 %
		over .5p to 1 in ¹	55	25	10 %
		over 1 in to 2 in	50	20	15 %
		over 2 in to 4 in	45	15	20 %
		over 4 inches	40	15	20 %
H04	HARD	.0625 to .188 in	80	45	---
		over .188 to .50 in	70	35	4 %
		over .50 to .75 in	65	30	6 %

RECTANGLES AND SQUARES

TEMPER		DISTANCE BETWEEN PARALLEL SURFACES		MINIMUM TENSILE STRENGTH + KSI	MINIMUM YIELD STRENGTH + KSI	ELONGATION IN 4 x THKNS MIN %
NEW DESIGNATION (ASTM B602)	FORMER DESIGNATION	THKNS by INCH	WIDTH by INCH			
060	SOFT	1 and under	6 and under	44	18	20 %
		over 1	6 and under	40	15	25 %
H02	HALF-HARD	.50 & under	1 and under	50	25	10 %
		.50 & under	over 1 to 6	45	17	15 %
		over .50 to 2	2 and under	45	17	15 %
		over .50 to 2	over 2 to 6	40	15	20 %
		over 2	over 2 to 4	40	15	20 %

¹ If specified for thread rolling applications, the minimum tensile strength shall be 52,000 PSI.

The dimensions and tolerances for material covered by this Specification (B16) can be found in Specification ASTM B249 or B250 (See P. 12-16 thru 12-21)

+ KSI = 1000 PSI

†† The full text of this ASTM is available for review at 78-567, or, for more information, call Norma, X2577 or Eval. Eng, Bella Geotina, 2315.

BRASS (CONT)

++ ASTM B16

HARDNESS REQUIREMENTS

RECTANGLES AND SQUARES

TEMPER		DISTANCE BETWEEN PARALLEL SURFACES		ROCKWELL B HARDNESS ³
NEW DESIGNATION	FORMER DESIGNATION	THICKNESS by INCH	WIDTH by INCH	
060	SOFT	.50 and over	.50 and over	10-35
H02	HALF-HARD	.50 and under	1 and under	45-85
		.50 and under	over .50 to 1	
		.50 and under	over 1 to 6	35-70
		over .50 to 2	2 and under	40-80
		over 2	over 2 to 6	35-70
			over 2 to 4	35-70

ROUNDS, HEXAGONS, OCTAGONS

TEMPER		DIAMETER	ROCKWELL B HARDNESS ³	
NEW DESIGNATION	FORMER DESIGNATION		ROUNDS	HEXAGONS, OCTAGONS
060	SOFT	.50 in and over	10-45	10-45
H02	HALF-HARD	.50 to 1 in ³	60-80	55-80
		over 1 to 2 in	55-75	45-70
		over 2 to 3 in	45-70	40-65
		over 3 to 4 in	40-65	35-60
		over 4 inches		

³ Determined on the cross section midway between surface and center.

+ KSI = 1000 PSI

++ The full text of this ASTM is available for review at 78-567, or, for more information call Norma, x2577 or Eval. Eng, Bella Geotina, 2315.

BRASS (CONT)

††ASTM B36

MECHANICAL PROPERTIES

COPPER ALLOY NO. C26000 AS PER ASTM B36

TEMPER		TENSILE STRENGTH		YIELD STRENGTH		APPROXIMATE ROCKWELL HARDNESS ¹							
						B SCALE				SUPERFICIAL 30-T			
						.02 to .036"		Over .036"		.012 to .028"		Over .028"	
STANDARD DESIGNATION (PER ASTM B601)	FORMER DESIGNATION	KSI+		KSI+		MIN	MAX	MIN	MAX	MIN	MAX	MIN	MAX
H01	QUARTER HARD	49	59	21	46	41	61	44	65	43	57	46	60
H02	HALF HARD	57	67	42	60	60	74	63	77	56	66	58	68
H03	THREE-QUARTER HARD	64	74	55	69	72	79	75	82	65	70	67	72
H04	HARD	71	81	67	78	79	84	81	86	70	73	71	74
H06	EXTRA-HARD	83	92	79	87	85	89	87	91	74	76	75	77
H08	SPRING	91	100	82	91	89	92	90	93	76	78	76	78
H10	EXTRA SPRING	95	104	86	93	91	94	92	95	77	79	77	79

APPROXIMATE ROCKWELL HARDNESS OF ANNEALED MATERIAL
UNS NOS. C26000 and C26800

ANNEALED TEMPER, NOMINAL GRAIN SIZE	STANDARD DESIGNATION (601)	APPROXIMATE ROCKWELL HARDNESS ¹			
		F SCALE		SUPERFICIAL 30-T	
		MIN	MAX	MIN	MAX
0.120-mm	OS120	50	62	--	21
0.070-mm	OS070	52	67	3	27
0.050-mm	OS050	61	73	20	35
0.035-mm	OS035	65	76	25	38
0.025-mm	OS025	67	79	27	42
0.015-mm	OS015	72	85	33	50

¹Rockwell Hardness values apply as follows:

- The F scale hardness values apply to metal 0.020 in (0.508 mm) and over in thickness, and
- The 30-T scale hardness values apply to metal 0.015 in (0.0381 mm) and over in thickness, and
- The B scale values apply to metal .020 inch and over in thickness.

+ KSI - 1000 PSI

†† The dimensions and tolerances for material covered by this Specification (B36) can be found in Specification ASTM B248. (See Pages 12-12 & 12-15.)

BRASS (CONT)

++ASTM B121

COPPER ALLOY NOS. C33500, C34000, C35000, C35300 AND C35600 AS PER ASTM B121

TEMPER		TENSILE STRENGTH +KSI		APPROXIMATE ROCKWELL HARDNESS ¹					
STANDARD DESIGNATION (PER ASTM B601)	FORMER DESIGNATION			B SCALE		F SCALE		30-T	
		MIN	MAX	MIN	MAX	MIN	MAX	MIN	MAX
H01	QUARTER-HARD	49	59	40	65	--	--	43	60
H02	HALF-HARD	55	65	57	74	--	--	54	66
H04	HARD	68	78	76	84	--	--	68	73
H06	EXTRA-HARD	79	89	83	89	--	--	73	76
H08	SPRING	86	95	87	92	--	--	75	78
H10	EXTRA-SPRING	90	99	88	93	--	--	76	79

APPROXIMATE ROCKWELL HARDNESS OF ANNEALED MATERIAL
COPPER ALLOY UNS NO. C33500, C34000, C34200, C35000, C35300, and C35600

TEMPER, NOMINAL GRAIN SIZE	STANDARD DESIGNATION	APPROXIMATE ROCKWELL HARDNESS ¹			
		F SCALE		SUPERFICIAL 30-T	
		MIN	MAX	MIN	MAX
0.070-mm	OS070	54	67	12	27
0.050-mm	OS050	61	73	20	35
0.035-mm	OS035	65	76	25	38
0.025-mm	OS025	67	79	27	42

¹ Rockwell Hardness values apply as follows:

The F scale hardness values apply to metal 0.020 in (0.508 mm) and over in thickness, and

The 30-T scale hardness values apply to metal 0.015 in (0.0381 mm) and over in thickness.

The B scale values apply to metal .020 inch and over in thickness.

+ KSI = 1000 PSI

++ The dimensions and tolerances for this Specification (B121) can be found in Specification ASTM B248. See P. 12-12 & 12-15 .

BRASS (CONT)

++ ASTM B 134

TENSILE STRENGTH REQUIREMENTS
FOR ROUND, HEXAGONAL, OCTAGONAL
AND SQUARE MATERIAL .02 AND
OVER IN DIAMETER.

ALLOY NUMBERS C26000, C27000, C27400

TEMPER		TENSILE STRENGTH + KSI	
STANDARD DESIGNATION (PER ASTM B601)	FORMER DESIGNATION	MIN	MAX
H00	EIGHTH-HARD	50	65
H01	QUARTER-HARD	62	77
H02	HALF-HARD	79	94
H03	THREE-QTR-HARD	92	107
H04	HARD ¹	102	117
H06	EXTRA-HARD ^{2 4}	115	129
H08	SPRING ^{3 4}	120	---

¹ Hard temper wire is not generally available in sizes over .5 inch diameter.

² Extra-hard temper is not generally available in sizes over .375 inch diameter.

³ Spring temper is not generally available in sizes over .25 inch diameter.

⁴ Square wire is not generally available in extra-hard or spring tempers.

+ KSI = 1000 PSI

++ The dimensions and tolerances for material covered by this Specification (B134) can be found in Specification ASTM B250. (See pages 12-20 and 12-21.)

TENSILE STRENGTH AND APPROXIMATE ROCKWELL HARDNESS FOR RECTANGULAR MATERIAL

COPPER ALLOY NUMBER C26000

TEMPER		TENSILE STRENGTH + KSI		APPROXIMATE ROCKWELL HARDNESS ⁵							
				B SCALE				SUPERFICIAL 30-T			
STANDARD DESIGNATION (PER ASTM B601)	FORMER DESIGNATION	MIN	MAX	.02 to .036 in		over .036 in		.012 to .028 in		over .028 in	
				MIN	MAX	MIN	MAX	MIN	MAX	MIN	MAX
H01	QUARTER-HARD	49	59	40	61	44	65	43	57	46	60
H02	HALF-HARD	57	67	60	74	63	77	56	66	58	68
H03	THREE-QTR-HARD	64	74	72	79	75	82	65	70	67	72
H04	HARD	71	81	79	84	81	86	70	73	71	74
H06	EXTRA-HARD	83	92	85	89	87	91	74	76	75	77
H08	SPRING	91	100	89	92	90	93	76	78	76	78
H10	EXTRA-SPRING	95	104	91	94	92	95	77	79	77	79

COPPER ALLOY NUMBERS C27000, C27400

TEMPER		TENSILE STRENGTH + KSI		APPROXIMATE ROCKWELL HARDNESS ⁵							
				B SCALE				SUPERFICIAL 30-T			
STANDARD DESIGNATION (PER ASTM B601)	FORMER DESIGNATION	MIN	MAX	.02 to .036 in		over .036 in		.012 to .028 in		over .028 in	
				MIN	MAX	MIN	MAX	MIN	MAX	MIN	MAX
H01	QUARTER-HARD	49	59	40	61	44	65	43	57	46	60
H02	HALF-HARD	55	65	57	71	60	74	54	64	56	66
H03	THREE-QTR-HARD	62	72	70	77	73	80	65	69	67	71
H04	HARD	68	78	76	82	78	84	68	72	69	73
H06	EXTRA-HARD	79	89	83	87	85	89	73	75	74	76
H08	SPRING	86	95	87	90	89	92	75	77	76	78
H10	EXTRA-SPRING	90	99	88	91	90	93	76	78	77	79

⁵ Rockwell hardness values apply as follows: The B scale values apply to metal .02 inch and over in thickness, and the 30-T scale values apply to metal .012 inch and over in thickness.

BRASS (CONT)

†† ASTM B135

MECHANICAL PROPERTIES
REQUIREMENTS OF DRAWN TEMPER TUBE

ALLOY	TEMPER	OUTSIDE DIA OR DISTANCE BETWEEN OUTSIDE PARALLEL SURFACES	WALL THICKNESS	TENSILE STRENGTH [†] KSI (MIN)	ROCKWELL HARDNESS 30T ¹
C20000	DRAWN (GENERAL PURPOSE)	ALL	ALL	40	38 MIN
	HARD DRAWN	UP TO 1 INCH	.02 TO .12 IN	52	55 MIN
		OVER 1 TO 2 IN	.035 TO .18 IN	52	55 MIN
		OVER 2 TO 4 IN	.06 TO .25 IN	52	55 MIN
C23000	LIGHT DRAWN	ALL	ALL	44-58	43-75
	DRAWN	ALL	ALL	44	43 MIN
	HARD DRAWN	UP TO 1 INCH	.02 TO .12 IN	57	65 MIN
		OVER 1 TO 2 IN	.035 TO .18 IN	57	65 MIN
OVER 2 TO 4 IN		.06 TO .25 IN	57	65 MIN	
C26000 C27000 C27200 C33000 C33200	DRAWN (GENERAL PURPOSE)	ALL	ALL	54	53 MIN
HARD DRAWN	UP TO 1 INCH	.02 TO .12 IN	66	70 MIN	
	OVER 1 TO 2 IN	.035 TO .18 IN	66	70 MIN	
	OVER 2 TO 4 IN	.060 TO .25 IN	66	70 MIN	

MECHANICAL PROPERTY REQUIREMENTS OF ANNEALED TEMPER TUBE

ALLOY	TEMPER	WALL THICKNESS	AVERAGE GRAIN SIZE		ROCKWELL HARDNESS ¹	
			MIN	MAX	MAX	SCALE
C26000, C33000, C33200	SOFT ANNEAL	UP TO .03 IN	.025	.06	40 MAX	30T
		OVER .03	.025	.06	80 MAX	F

¹ Rockwell hardness values apply only to tubes having a wall thickness of .012 inch or over and to round tubes having an inside diameter of .312 inch or over. Rockwell hardness shall be made on the inside surface of the tube.

The dimensions and tolerances for material covered by this Specification (B135) can be found in Specification ASTM B251 ††. (See p. 12-22 & 12-23)

† KSI = 1000 PSI

†† The full text of this ASTM is available for review at 78-567, or, for more information call Norma - Ext. 2577.

8

BRASS (CONT)

†† ASTM B135

MECHANICAL PROPERTY REQUIREMENTS OF ANNEALED TEMPER TUBE

ALLOY	TEMPER	WALL THICKNESS, INCHES	ROCKWELL HARDNESS ¹		AVERAGE GRAIN SIZE, MM	
			SCALE	MAX	MIN	MAX
C22000	SOFT ANNEAL	UP TO 0.045, INCL	30T	30	0.025	0.060
		OVER 0.045	F	70	0.025	0.060
	LIGHT ANNEAL	UP TO 0.045, INCL	30T	37	²	0.035
		OVER 0.045	F	78	²	0.035
C23000	SOFT ANNEAL	UP TO 0.045, INCL	30T	36	0.025	0.060
		OVER 0.045	F	75	0.025	0.060
	LIGHT ANNEAL	UP TO 0.045, INCL	30T	39	²	0.035
		OVER 0.045	F	85	²	0.035
C26000, C33000, and C33200	SOFT ANNEAL	UP TO 0.030, INCL	30T	40	0.025	0.060
		OVER 0.030	F	80	0.025	0.060
C26000, C28000, C33000, C33200, and C37000	LIGHT ANNEAL	UP TO 0.030, INCL	30T	60	²	0.035
		OVER 0.030	F	90	²	0.035
C27000 and C27200	SOFT ANNEAL	UP TO 0.030, INCL	30T	40	0.025	0.060
		OVER 0.030	F	80	0.025	0.060
	LIGHT ANNEAL	UP TO 0.030, INCL	30T	60	²	0.035
		OVER 0.030	F	90	²	0.035

¹ ROCKWELL HARDNESS VALUES SHALL APPLY ONLY TO TUBES HAVING A WALL THICKNESS OF 0.015 IN. OR OVER AND TO ROUND TUBES HAVING AN INSIDE DIAMETER OF .3125 IN. OR OVER AND TO RECTANGULAR INCLUDING SQUARE TUBES HAVING AN INSIDE MAJOR DISTANCE BETWEEN PARALLEL SURFACES OF .3125 IN. OR OVER. FOR ALL OTHER TUBE NO ROCKWELL HARDNESS VALUES SHALL APPLY. ROCKWELL HARDNESS TESTS SHALL BE MADE ON THE INSIDE SURFACE OF THE TUBE.

² ALTHOUGH NO MINIMUM GRAIN SIZE IS SPECIFIED, THE PRODUCT MUST NEVERTHELESS HAVE A FULLY RECRYSTALLIZED GRAIN STRUCTURE.

8

BRASS (CONT)

†† ASTM B453

MECHANICAL PROPERTIES

TEMPER	DIAMETER OR DISTANCE BETWEEN PARALLEL SURFACES IN.	TENSILE STRENGTH † KSI (MIN)	YIELD STRENGTH † KSI (MIN)	ELONGATION IN 4 X DIAMETER OR THICKNESS MIN %
SOFT	.5 AND UNDER	46	16	20
	OVER .5 TO 1.	44	15	25
	OVER 1.	40	15	30
QTR-HARD	.5 AND UNDER	52	25	10
	OVER .5 TO 1.	50	20	15
	OVER 1.	42	15	20
HALF-HARD	.5 AND UNDER	57	25	7
	OVER .5 TO 1.	55	25	10
	OVER 1.	50	20	15

HARDNESS REQUIREMENTS

TEMPER	DIAMETER OR DISTANCE BETWEEN PARALLEL SURFACES, IN.	ROCKWELL B HARDNESS DETERMINED ON THE CROSSSECTION MIDWAY BETWEEN SURFACE AND CENTER
SOFT	OVER .5	45 MAX
QTR-HARD	OVER .5 TO 1.	50-75
	OVER 1. TO 2.	40-70
	OVER 2.	35-65
HALF-HARD	OVER .5 TO 1.	60-80
	OVER 1. TO 2.	55-75
	OVER 2.	40-70

† KSI = 1000 PSI

†† The dimensions and tolerances for material covered by this Specification (B453) can be found in Specification ASTM B249 (See Pages 12-14 thru 12-17).

The full text of this ASTM is available for review at 78-567 or, for more information, Call Norma at Ext. 2577.

BRASS (CONT)

WEIGHT (LBS PER FT)

ASTM B16, ALLOY C36000

ROUND FREE-CUTTING BRASS ROD

SCREW MACHINE QUALITY
12 Foot Lengths

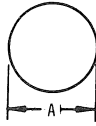

DIMENSION "A" INCHES	POUNDS PER FOOT	POUNDS 12' LENGTH
1/16	.0113	.136
5/64	.0177	.212
3/32	.0254	.305
7/64	.0346	.415
1/8	.0452	.542
9/64	.0572	.686
5/32	.0706	.847
11/64	.0855	1.03
3/16	.102	1.22
13/64	.119	1.43
7/32	.138	1.66
15/64	.159	1.91
1/4	.181	2.17
17/64	.204	2.45
9/32	.229	2.75
19/64	.255	3.06
5/16	.283	3.40
21/64	.312	3.74
11/32	.342	4.10
23/64	.374	4.49
3/8	.407	4.88
25/64	.441	5.29
13/32	.478	5.74
27/64	.515	6.18
7/16	.554	6.65
29/64	.594	7.13
15/32	.636	7.63
31/64	.679	8.15
1/2	.723	8.68
33/64	.769	9.23
17/32	.817	9.80
9/16	.915	11.0
19/32	1.02	12.2
5/8	1.13	13.6
21/32	1.25	15.0
11/16	1.37	16.4
23/32	1.49	17.9
3/4	1.63	19.6
25/32	1.77	21.2
13/16	1.91	22.9
27/32	2.06	24.7
7/8	2.22	26.6
29/32	2.38	28.6
15/16	2.54	30.5
31/32	2.72	32.6
1	2.89	34.7
1-1/16	3.27	39.2
1-1/8	3.66	43.9
1-3/16	4.08	49.0
1-7/32	4.29	51.5

DIMENSION "A" INCHES	POUNDS PER FOOT	POUNDS 12' LENGTH
1-1/4	4.52	54.2
1-5/16	4.98	59.8
1-3/8	5.47	65.6
1-7/16	5.98	71.8
1-1/2	6.51	78.1
1-9/16	7.06	84.7
1-5/8	7.64	91.7
1-11/16	8.24	98.9
1-3/4	8.86	106.
1-13/16	9.51	114.
1-7/8	10.2	122.
1-15/16	10.9	131.
2	11.6	139.
2-1/8	13.1	157.
2-5/32	13.4	161.
2-1/4	14.6	175.
2-3/8	16.3	196.
2-7/16	17.2	206.
2-1/2	18.1	217.
2-5/8	19.9	239.
2-3/4	21.9	263.
2-7/8	23.9	287.
3	26.0	312.
3-1/8	28.2	338.
3-1/4	30.6	367.
3-1/2	35.4	425.
3-5/8	38.0	456.
3-3/4	40.7	488.
4	46.3	556.
4-1/4	52.3	628.
4-1/2	58.6	703.
4-3/4	65.3	784.
5	72.3	868.
5-1/2	87.5	1050.
6	104.	1248.
6-1/2	122.	1464.
7	142.	1704.
8	185.	2220.
9	234.	2808.
10	289.	3468.
11	350.	4200.
12	416.	4992.

HEXAGON FREE-CUTTING BRASS ROD

SCREW MACHINE QUALITY
12 Foot Lengths

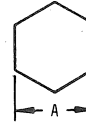

DIMENSION "A" INCHES	POUNDS PER FOOT	POUNDS 12' LENGTH
1/16	.0125	.150
3/32	.0280	.336
1/8	.0499	.599
5/32	.0779	.935
3/16	.112	1.34
7/32	.153	1.84
1/4	.199	2.39
9/32	.252	3.02
5/16	.312	3.74
11/32	.377	4.52
3/8	.449	5.39
13/32	.527	6.32
7/16	.611	7.33
15/32	.701	8.41
1/2	.798	9.58
9/16	1.01	12.1
19/32	1.13	13.6
5/8	1.25	15.0
11/16	1.51	18.1
3/4	1.80	21.6
13/16	2.11	25.3
7/8	2.44	29.3
15/16	2.80	33.6
1	3.19	38.3
1-1/16	3.60	43.2
1-1/8	4.04	48.5
1-3/16	4.50	54.0

DIMENSION "A" INCHES	POUNDS PER FOOT	POUNDS 12' LENGTH
1-1/4	4.99	59.9
1-5/16	5.50	66.0
1-3/8	6.03	72.4
1-7/16	6.59	79.1
1-1/2	7.18	86.2
1-9/16	7.79	93.5
1-5/8	8.43	101.
1-11/16	9.09	109.
1-3/4	9.77	117.
1-13/16	10.5	126.
1-7/8	11.2	134.
1-15/16	12.0	144.
2	12.8	154.
2-1/8	14.4	173.
2-1/4	16.2	194.
2-3/8	18.0	216.
2-1/2	19.9	239.
2-5/8	22.0	264.
2-3/4	24.1	289.
2-7/8	26.4	317.
3	28.7	344.
3-1/8	31.2	374.
3-1/4	33.7	404.
3-1/2	39.1	469.
3-3/4	44.9	539.
4	51.1	613.

SQUARE FREE-CUTTING BRASS BAR

SCREW MACHINE QUALITY
12 Foot Lengths

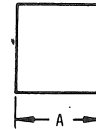

DIMENSION "A" INCHES	POUNDS PER FOOT	POUNDS 12' LENGTH
3/32	.0324	.389
1/8	.0576	.691
5/32	.0899	1.08
3/16	.130	1.56
7/32	.176	2.11
1/4	.230	2.76
5/16	.360	4.32
3/8	.518	6.22
7/16	.705	8.46
1/2	.921	11.1
9/16	1.17	14.0
5/8	1.44	17.3
11/16	1.74	20.9
3/4	2.07	24.8
13/16	2.43	29.2
8/8	2.82	33.8
15/16	3.24	38.9

DIMENSION "A" INCHES	POUNDS PER FOOT	POUNDS 12' LENGTH
1	3.68	44.2
1-1/8	4.66	55.9
1-1/4	5.76	69.1
1-3/8	6.97	83.6
1-1/2	8.29	99.5
1-5/8	9.73	117.
1-3/4	11.3	136.
2	14.7	176.
2-1/8	16.6	199.
2-1/4	18.7	224.
2-1/2	23.0	276.
2-3/4	27.9	335.
3	33.2	398.
3-1/2	45.1	541.
4	58.9	707.
4-1/4	66.5	798.
4-1/2	74.6	895.

HALF-ROUND FREE-CUTTING BRASS ROD

12 Foot Mill Lengths

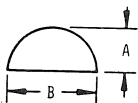

DIMENSION "A" INCHES	DIMENSION "B" INCHES	POUNDS PER FOOT	POUNDS 12' LENGTH
1/8	1/4	.0905	1.09
5/32	5/16	.142	1.70
3/16	3/8	.204	2.45
1/4	1/2	.362	4.34
5/16	5/8	.565	6.78
3/8	3/4	.815	9.78
7/16	7/8	1.11	13.3
1/2	1	1.45	17.4
5/8	1-1/4	2.26	27.1
1	2	5.80	69.6

HALF-OVAL FREE-CUTTING BRASS ROD

12 Foot Mill Lengths

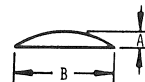

DIMENSION "A" INCHES	DIMENSION "B" INCHES	POUNDS PER FOOT	POUNDS 12' LENGTH
3/32	3/8	.102	1.22
1/8	1/2	.183	2.20
5/32	5/8	.283	3.40
3/16	3/4	.408	4.90
1/4	3/4	.544	6.53
7/32	7/8	.555	6.66
1/4	1	.723	8.68

BRASS (CONT)

WEIGHT (LBS PER FT)

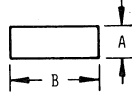

ASTM B16, ALLOY C36000

RECTANGULAR FREE-CUTTING BRASS BAR
SCREW MACHINE QUALITY

DIMENSION "A" INCHES	DIMENSION "B" INCHES	POUNDS PER FOOT	POUNDS 12' LENGTH	
1/16	x 1/4	.057	.684	
	3/8	.086	1.03	
	1/2	.115	1.38	
	5/8	.144	1.73	
	3/4	.172	2.06	
	7/8	.201	2.41	
	1	.230	2.76	
	1-1/2	.345	4.14	
	2	.459	5.51	
	3/32	x 1/4	.0857	1.03
		3/8	.129	1.55
		1/2	.171	2.05
5/8		.214	2.57	
3/4		.258	3.10	
7/8		.300	3.60	
1		.343	4.12	
1-1/4		.428	5.14	
1-1/2		.514	6.17	
2		.685	8.22	
2-1/2		.857	10.3	
1/8		x 3/16	.0863	1.04
	1/4	.115	1.38	
	5/16	.144	1.73	
	3/8	.172	2.06	
	7/16	.201	2.41	
	1/2	.230	2.76	
	9/16	.259	3.11	
	5/8	.287	3.44	
	3/4	.344	4.13	
	7/8	.402	4.82	
	1	.459	5.51	
	1-1/4	.574	6.89	
	1-3/8*	.633	7.60	
	1-1/2	.689	8.27	
	1-3/4	.803	9.64	
	2	.918	11.0	
	2-1/4	1.03	12.4	
	2-1/2	1.15	13.8	
	2-3/4	1.27	15.2	
	3	1.38	16.6	
	4	1.84	22.1	
	3/16	x 1/4	.172	2.06
		5/16	.217	2.60
		3/8	.258	3.10
7/16		.304	3.65	
1/2		.344	4.13	
5/8		.430	5.16	
3/4		.516	6.19	
7/8		.602	7.22	
1		.688	8.26	
1-1/8		.777	9.32	
1-1/4		.860	10.3	
1-3/8		.950	11.4	
1-1/2		1.03	12.4	
1-3/4		1.20	14.4	
2		1.38	16.6	
2-1/2		1.72	20.6	
3		2.07	24.8	
3-1/2		2.41	28.9	
4		2.75	33.0	
1/4		x 5/16	.287	3.44
		3/8	.344	4.13
		1/2	.459	5.51
		5/8	.574	6.89
		3/4	.688	8.26
	7/8	.803	9.64	
	1	.918	11.0	
	1-1/8	1.04	12.5	
	1-1/4	1.15	13.8	
	1-1/2	1.38	16.6	
	1-3/4	1.61	19.3	
	2	1.84	22.1	
	2-1/4	2.07	24.8	
	2-1/2	2.30	27.6	
	2-3/4	2.53	30.4	
	3	2.75	33.0	
	3-1/2	3.21	38.5	
	4	3.67	44.0	
	5	4.61	55.3	
	6	5.51	66.1	

DIMENSION "A" INCHES	DIMENSION "B" INCHES	POUNDS PER FOOT	POUNDS 12' LENGTH	
5/16	x 3/8	.430	5.16	
	1/2	.574	6.89	
	5/8	.717	8.60	
	3/4	.861	10.3	
	7/8	1.00	12.0	
	1	1.15	13.8	
	1-1/4	1.43	17.2	
	1-1/2	1.72	20.6	
	1-3/4	2.01	24.1	
	2	2.30	27.6	
	2-1/2	2.87	34.4	
	2-3/4	3.17	38.0	
3	3.44	41.3		
3-1/2	4.01	48.1		
4	4.61	55.3		
4-1/2	5.18	62.2		
3/8	x 1/2	.688	8.26	
	5/8	.861	10.3	
	3/4	1.03	12.4	
	7/8	1.20	14.4	
	1	1.38	16.6	
	1-1/4	1.72	20.6	
	1-1/2	2.07	24.8	
	1-3/4	2.41	28.9	
	2	2.75	33.0	
	2-1/4	3.09	37.1	
	2-1/2	3.44	41.3	
	2-3/4	3.80	45.6	
3	4.13	49.6		
3-1/2	4.82	57.8		
4	5.51	66.1		
4-1/2	6.22	74.6		
5	6.88	82.6		
6	8.26	99.1		
7/16	x 3/4	1.20	14.4	
	1	1.61	19.3	
	1-1/4	2.36	28.3	
	1/2	x 5/8	1.15	13.8
		3/4	1.38	16.6
		7/8	1.61	19.3
1		1.84	22.1	
1-1/4		2.30	27.6	
1-3/8		2.53	30.4	
1-1/2	2.76	33.1		
1-3/4	3.22	38.6		
2	3.67	44.0		
2-1/4	4.13	49.6		
2-1/2	4.59	55.1		
3	5.51	66.1		
3-1/2	6.43	77.2		
4	7.34	88.1		
4-1/2	8.29	99.5		
5	9.18	110.		
6	11.0	132.		
5/8	x 3/4	1.72	20.6	
	7/8	2.01	24.1	
	1	2.30	27.6	
	1-1/4	2.87	34.4	
	1-3/8	3.17	38.0	
	1-1/2	3.45	41.4	
	1-3/4	4.02	48.2	
	2	4.59	55.1	
	2-1/4	5.18	62.2	
	2-1/2	5.74	68.9	
	3	6.90	82.8	
	4	9.18	110.	
3/4	x 7/8	2.42	29.0	
	1	2.75	33.0	
	1-1/4	3.44	41.3	
	1-1/2	4.13	49.6	
	1-3/4	4.82	57.8	
	2	5.50	66.0	
	2-1/4	6.22	74.6	
	2-1/2	6.88	82.6	
	3	8.26	99.1	
	3-1/2	9.67	116.	
	4	11.0	132.	
	5	13.8	166.	
6	16.5	198.		

DIMENSION "A" INCHES	DIMENSION "B" INCHES	POUNDS PER FOOT	POUNDS 12' LENGTH
7/8	x 1	3.21	38.5
	1-1/4	4.03	48.4
	1-1/2	4.84	58.1
	2	6.42	77.0
1	x 1-1/4	4.59	55.1
	1-1/2	5.51	66.1
	1-3/4	6.43	77.2
	2	7.34	88.1
	2-1/4	8.26	99.1
	2-1/2	9.18	110.
1-1/4	x 1-1/2	6.89	82.7
	1-3/4	8.06	96.7
	2	9.18	110.
	2-1/4	10.2	122.
	2-1/2	11.5	138.
	3	13.8	166.
1-1/2	x 1-1/2	16.1	193.
	3-1/2	18.4	221.
	4	22.0	264.
	6	33.0	396.
1-3/8	x 2	10.1	121.
1-1/2	x 1-3/4	9.67	116.
	2	11.0	132.
	2-1/4	12.4	149.
	2-1/2	13.8	166.
1-3/4	x 2	16.5	198.
	3	22.0	264.
	4	33.0	396.
	6	66.1	792.
2	x 2-1/2	18.4	221.
	2-3/4	20.3	244.
	3	22.0	264.
	3-1/2	25.8	310.
2-1/2	x 3	29.4	353.
	3	32.5	390.
	3-1/2	37.5	450.
	4	44.0	528.
3	x 4	44.2	530.
	5	55.2	662.

BRASS (CONT)

WEIGHT (LBS PER FT)

ASTM B134, ALLOY C26000

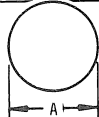

SPRING BRASS WIRE
IN COILS

DIMENSION "A"		POUNDS PER FOOT	LINEAL FEET PER POUND
IN INCHES	FRACTION OR B & S GAUGE		
.010	30 ga.	.0003	3334.
.0201	24 ga.	.0012	840.
.032	20 ga.	.0029	345.
.0403	18 ga.	.0047	213.
.0508	16 ga.	.0074	135.
.0641	14 ga.	.0118	85.0
.072	13 ga.	.0150	67.0
.0808	12 ga.	.0188	53.5
.0907	11 ga.	.0237	42.5
.1019	10 ga.	.0299	33.5
.1285	8 ga.	.0476	21.0
.1443	7 ga.	.0600	16.7
.1819	5 ga.	.0954	10.5

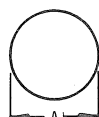

COLD HEADING BRASS WIRE
IN COILS

DIMENSION "A" DIA.		POUNDS PER FOOT	LINEAL FEET PER POUND
IN INCHES			
.136		.0533	18.8
.182		.0953	10.5
.200		.1152	8.7
.225		.1457	6.9
.270		.2100	4.8
.305		.2678	3.8
.315		.2857	3.5
.360		.3732	2.7
.399		.4585	2.2
.440		.5576	1.8
.518		.7727	1.3



SOFT BRASS WIRE
IN COILS

DIMENSION "A"		POUNDS PER FOOT	LINEAL FEET PER POUND
IN INCHES	FRACTION OR B & S GAUGE		
.032	20 ga.	.0029	345.
.0641	14 ga.	.0118	85.0
.0907	11 ga.	.0237	42.5
.1285	8 ga.	.0476	21.0

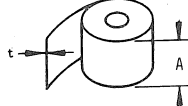

ASTM B19, B36, ALLOY C26000
SOFT BRASS
IN ROLLS

THICKNESS "t"		WIDTH "A" INCHES	POUNDS LINEAL FOOT
IN INCHES	FRACTION OR B & S GAUGE		
.005	36 ga.	6	.111
.005	36 ga.	12	.222
.006	34 ga.	6	.133
.008	32 ga.	6	.177
.008	32 ga.	12	.355
.010	30 ga.	6	.220
.010	30 ga.	12	.440
.0126	28 ga.	6	.279
.0126	28 ga.	12	.559
.0126	28 ga.	18	.838
.0159	26 ga.	6	.352
.0159	26 ga.	8	.470
.0159	26 ga.	12	.705
.0159	26 ga.	24	1.41
.0179	25 ga.	6	.397
.0179	25 ga.	12	.794
.0179	25 ga.	24	1.59
.0201	24 ga.	6	.445
.0201	24 ga.	8	.594
.0201	24 ga.	12	.891
.0201	24 ga.	24	1.78
.0253	22 ga.	6	.560
.0253	22 ga.	8	.748
.0253	22 ga.	12	1.12
.0253	22 ga.	24	2.24
.0285	21 ga.	6	.630
.0285	21 ga.	8	.839
.0285	21 ga.	12	1.26
.0285	21 ga.	24	2.52
.032	20 ga.	6	.710
.032	20 ga.	8	.946
.032	20 ga.	12	1.42
.032	20 ga.	24	2.84
.036	19 ga.	6	.796
.036	19 ga.	12	1.59
.036	19 ga.	24	3.18
.0403	18 ga.	6	.895
.0403	18 ga.	12	1.79
.0453	18 ga.	24	3.58
.0453	17 ga.	6	1.00
.0453	17 ga.	12	2.00
.0508	16 ga.	6	1.13
.0508	16 ga.	12	2.25
.0508	16 ga.	24	4.50
.0571	15 ga.	6	1.26
.0571	15 ga.	12	2.52
.0625	1/16	6	1.39
.0625	1/16	12	2.77
.0625	1/16	24	5.54
.0641	14 ga.	6	1.41
.0641	14 ga.	12	2.83
.0641	14 ga.	24	5.66
.072	13 ga.	12	3.19

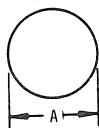

HALF HARD BRASS WIRE
IN COILS

DIMENSION "A"		POUNDS PER FOOT	LINEAL FEET PER POUND
IN	FRACTION OR B & S GAUGE		
.0403	18 ga.	.0047	213.
.0808	12 ga.	.0188	53.5
.0907	11 ga.	.0239	42.5

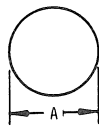

FULL HARD BRASS WIRE
12 Foot Mill Lengths

DIMENSION "A"		POUNDS PER FOOT	LINEAL FEET PER POUND
IN INCHES	FRACTION OR B & S GAUGE		
.0907	11 ga.	.0237	42.5
.114	9 ga.	.0377	26.6
.1285	8 ga.	.0476	21.0
.162	6 ga.	.0757	13.2
.1875	3/16	.102	9.8
.250	1/4	.181	5.5

BRASS (CONT)

WEIGHT (LBS PER FT)

ASTM B19, B36, ALLOY C26000

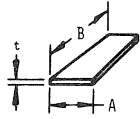

SOFT BRASS SHEET

THICKNESS "t"		WIDTH "A" INCHES	LENGTH "B" INCHES	POUNDS LINEAL FOOT
IN INCHES	FRACTION OR B & S GAUGE			
.010	30 ga.	12	96	.443
.0126	28 ga.	12	96	.572
.0159	26 ga.	12	96	.705
.0159	26 ga.	18	96	1.06
.018	25 ga.	12	96	.789
.0201	24 ga.	12	96	.886
.0201	24 ga.	24	96	1.77
.0253	22 ga.	12	96	1.12
.0253	22 ga.	18	96	1.68
.0253	22 ga.	24	96	2.24
.032	20 ga.	12	96	1.41
.032	20 ga.	18	96	2.12
.032	20 ga.	24	96	2.82
.032	20 ga.	36	96	4.23
.036	19 ga.	12	96	1.59
.036	19 ga.	24	96	3.18
.0403	18 ga.	12	96	1.78
.0403	18 ga.	18	96	2.67
.0403	18 ga.	24	96	3.56
.0403	18 ga.	36	96	5.34
.0453	17 ga.	12	96	2.00
.0508	16 ga.	12	96	2.25
.0508	16 ga.	24	96	4.60
.0508	16 ga.	36	96	6.75
.0571	15 ga.	12	96	2.53
.0625	1/16	12	96	2.75
.0625	1/16	18	96	4.13
.0625	1/16	24	96	5.50
.0625	1/16	36	96	8.25
.072	13 ga.	12	96	3.17
.0808	12 ga.	12	96	3.58
.093	3/32	12	96	4.13
.093	3/32	18	96	6.20
.093	3/32	24	96	8.26
.093	3/32	36	96	12.39
.1019	10 ga.	12	96	4.52
.1144	9 ga.	12	96	5.07
.125	1/8	12	96	5.50
.125	1/8	24	96	11.02
.125	1/8	36	96	16.53
.156	5/32	12	96	6.85
.1875	3/16	12	96	8.26
.1875	3/16	24	96	16.52
.1875	3/16	36	96	24.78
.218	7/32	12	96	9.64
.250	1/4	12	96	11.0
.250	1/4	24	96	22.0
.250	1/4	36	96	33.0

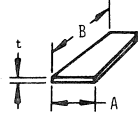

HALF HARD BRASS SHEET

THICKNESS "t"		WIDTH "A" INCHES	LENGTH "B" INCHES	POUNDS LINEAL FOOT
IN INCHES	FRACTION OR B & S GAUGE			
.010	30 ga.	12	96	.441
.0126	28 ga.	12	96	.572
.0159	26 ga.	12	96	.705
.0159	26 ga.	18	96	1.05
.018	25 ga.	12	96	.789
.0201	24 ga.	12	96	.886
.0201	24 ga.	24	96	1.77
.0253	22 ga.	12	96	1.12
.0253	22 ga.	18	96	1.65
.0253	22 ga.	24	96	2.24
.032	20 ga.	12	96	1.41
.032	20 ga.	18	96	2.11
.032	20 ga.	24	96	2.82
.032	20 ga.	36	96	4.22
.036	19 ga.	12	96	1.58
.036	19 ga.	24	96	3.16
.0403	18 ga.	12	96	1.78
.0403	18 ga.	18	96	2.67
.0403	18 ga.	24	96	3.56
.0403	18 ga.	36	96	5.34
.0453	17 ga.	12	96	2.00
.0508	16 ga.	12	96	2.24
.0508	16 ga.	24	96	4.48
.0508	16 ga.	36	96	6.72
.0571	15 ga.	12	96	2.52
.0625	1/16	12	96	2.75
.0625	1/16	24	96	5.50
.0625	1/16	36	96	8.25
.072	13 ga.	12	96	3.17
.0808	12 ga.	12	96	3.56
.093	3/32	12	96	4.13
.093	3/32	24	96	8.26
.093	3/32	36	96	12.39
.1019	10 ga.	12	96	4.49
.1144	9 ga.	12	96	5.04
.125	1/8	12	96	5.50
.125	1/8	24	96	11.02
.125	1/8	36	96	16.53
.156	5/32	12	96	6.85
.1875	3/16	12	96	8.26
.1875	3/16	24	96	16.52
.1875	3/16	36	96	24.78
.218	7/32	12	96	9.64
.250	1/4	12	96	11.0
.250	1/4	24	96	22.0
.250	1/4	36	96	33.0

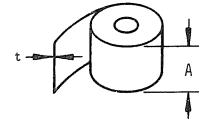

THICKNESS "t"		WIDTH "A" INCHES	POUNDS LINEAL FOOT
IN INCHES	FRACTION OR B & S GAUGE		
.001	50 ga.	6	.0221
.0015	46 ga.	6	.0331
.002	44 ga.	6	.0444
.003	40 ga.	6	.0665
.004	38 ga.	6	.0886
.005	36 ga.	6	.111
.005	36 ga.	12	.222
.006	34 ga.	6	.133
.007	33 ga.	6	.155
.008	32 ga.	6	.177
.008	32 ga.	12	.355
.010	30 ga.	6	.222
.010	30 ga.	12	.444
.0126	28 ga.	6	.279
.0126	28 ga.	12	.559
.0126	28 ga.	18	.839
.0159	26 ga.	6	.352
.0159	26 ga.	8	.470
.0159	26 ga.	12	.705
.0159	26 ga.	24	1.41
.0179	25 ga.	6	.397
.0179	25 ga.	12	.794
.0179	25 ga.	24	1.59
.0201	24 ga.	6	.445
.0201	24 ga.	12	.891
.0201	24 ga.	24	1.78
.0253	22 ga.	6	.561
.0253	22 ga.	8	.748
.0253	22 ga.	12	1.12
.0253	22 ga.	24	2.24
.0285	21 ga.	6	.632
.0285	21 ga.	8	.839
.0285	21 ga.	12	1.26
.0285	21 ga.	24	2.52
.032	20 ga.	6	.710
.032	20 ga.	12	1.42
.032	20 ga.	24	2.84
.036	19 ga.	6	.796
.036	19 ga.	12	1.59
.036	19 ga.	24	3.18
.0403	18 ga.	6	.895
.0403	18 ga.	12	1.79
.0403	18 ga.	24	3.58
.0453	17 ga.	6	1.00
.0453	17 ga.	12	2.00
.0508	16 ga.	6	1.13
.0508	16 ga.	12	2.25
.0508	16 ga.	24	4.50
.0571	15 ga.	6	1.27
.0571	15 ga.	12	2.54
.0625	1/16	6	1.38
.0625	1/16	12	2.75
.0625	1/16	24	5.50
.0641	14 ga.	6	1.42
.0641	14 ga.	12	2.84
.0641	14 ga.	24	5.68
.072	13 ga.	12	3.19

BRASS (CONT)

WEIGHT (LBS PER FT)

ASTM B19, B36 / ALLOY C26000

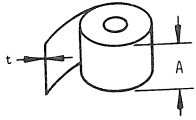

SPRING BRASS
IN ROLLS

THICKNESS "t"		WIDTH "A" INCHES	POUNDS LINEAL FOOT
IN INCHES	FRACTION OR B & S GAUGE		
.010	30 ga.	12	.444
.0126	28 ga.	6	.279
.0159	26 ga.	6	.352
.0201	24 ga.	6	.445
.0201	24 ga.	12	.891
.0253	22 ga.	6	.561
.0253	22 ga.	12	1.12
.032	20 ga.	6	.710
.032	20 ga.	12	1.42
.0359	19 ga.	6	.796
.0359	19 ga.	12	1.59
.040	18 ga.	6	.887
.040	18 ga.	12	1.77
.0508	16 ga.	6	1.13
.0508	16 ga.	12	2.25
.0641	14 ga.	6	1.42
.0641	14 ga.	12	2.84

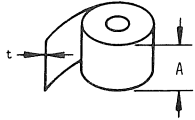

ONE-QUARTER HARD BRASS
IN ROLLS

THICKNESS "t"		WIDTH "A" INCHES	POUNDS LINEAL FOOT
IN INCHES	FRACTION OR B & S GAUGE		
.010	30 ga.	12	.444
.0201	24 ga.	6	.445
.0201	24 ga.	12	.891
.0201	24 ga.	24	1.78
.0253	22 ga.	6	.561
.0253	22 ga.	12	1.12
.0253	22 ga.	24	2.24
.0285	21 ga.	10	1.05
.0285	21 ga.	12	1.26
.032	20 ga.	6	.710
.032	20 ga.	12	1.42
.032	20 ga.	24	2.84
.036	19 ga.	6	.796
.0403	18 ga.	6	.895
.0403	18 ga.	12	1.79
.0403	18 ga.	24	3.58
.0508	16 ga.	6	1.13
.0508	16 ga.	12	2.25
.0641	14 ga.	6	1.42
.0641	14 ga.	12	2.84
.0641	14 ga.	24	5.68

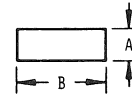

HARD BRASS STRIP
Slit Edge - 12 Foot Mill Lengths

DIMENSION "A" INCHES	DIMENSION "B" INCHES	POUNDS PER FOOT	POUNDS 12' LENGTHS
1/16	x 1/4	.0578	.694
	3/8	.0866	1.04
	1/2	.116	1.39
	5/8	.143	1.72
	3/4	.173	2.08
1/8	7/8	.201	2.41
	1	.231	2.77
	1-1/2	.347	4.16
	2	.462	5.54
	3/32	x 1/4	.086
3/8		.129	1.55
1/2		.172	2.06
5/8		.215	2.58
3/4		.258	3.10
1/4	7/8	.301	3.61
	1	.344	4.13
	1-1/4	.433	5.20
	1-1/2	.520	6.24
	2	.693	8.32
1/2	2-1/2	.866	10.4

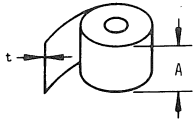

HARD BRASS
IN ROLLS

THICKNESS "t"		WIDTH "A" INCHES	POUNDS LINEAL FOOT
IN INCHES	FRACTION OR B & S GAUGE		
.001	50 ga.	6	.0221
.0015	46 ga.	6	.0331
.002	44 ga.	6	.0444
.003	40 ga.	6	.0665
.004	38 ga.	6	.0886
.005	36 ga.	6	.111
.005	36 ga.	12	.222
.006	34 ga.	6	.133
.007	33 ga.	6	.155
.008	32 ga.	6	.177
.008	32 ga.	12	.355
.010	30 ga.	6	.222
.010	30 ga.	12	.444
.0159	26 ga.	6	.352
.0159	26 ga.	12	.705
.0179	25 ga.	12	.794
.0201	24 ga.	6	.445
.0201	24 ga.	12	.891
.0253	22 ga.	6	.561
.0253	22 ga.	12	1.12
.032	20 ga.	6	.710
.032	20 ga.	12	1.42
.036	19 ga.	6	.796
.0403	18 ga.	6	.895
.0403	18 ga.	12	1.79
.0508	16 ga.	6	1.13
.0508	16 ga.	12	2.25
.064	14 ga.	6	1.42
.064	14 ga.	12	2.84

BRASS (CONT)

WEIGHT (LBS PER FT)

ASTM B135, ALLOY C26000

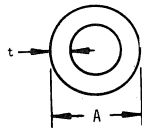

BRASS TUBE

12 Foot Mill Lengths

DIMENSION "A" INCHES	DIMENSION "t"		POUNDS PER FOOT	POUNDS 12' LENGTH
	IN INCHES	FRACTION OR STUBS' GAUGE		
1/8	.016	27 ga.	.0202	.242
1/8	.028	22 ga.	.0316	.379
1/8	.032	21 ga.	.0345	.414
1/8	.035	20 ga.	.0366	.439
5/32	.016	27 ga.	.0260	.312
5/32	.035	20 ga.	.0493	.592
3/16	.020	25 ga.	.0389	.467
3/16	.025	25 ga.	.0472	.566
3/16	.028	22 ga.	.0519	.623
3/16	.032	21 ga.	.0578	.694
3/16	.049	18 ga.	.0788	.942
1/4	.028	22 ga.	.0722	.866
1/4	.032	21 ga.	.0810	.972
1/4	.049	18 ga.	.114	1.37
1/4	.065	16 ga.	.139	1.67
5/16	.025	23 ga.	.083	1.00
5/16	.032	21 ga.	.104	1.25
5/16	.049	18 ga.	.150	1.80
5/16	.065	16 ga.	.187	2.24
3/8	.025	23 ga.	.102	1.22
3/8	.032	21 ga.	.128	1.54
3/8	.049	18 ga.	.186	2.23
3/8	.065	16 ga.	.234	2.81
3/8	.072	13 ga.	.254	3.05
3/8	.087	12 ga.	.288	3.46
3/8	.093	11 ga.	.306	3.67
7/16	.020	25 ga.	.097	1.16
7/16	.032	21 ga.	.151	1.81
7/16	.049	18 ga.	.221	2.65
7/16	.065	16 ga.	.281	3.37
1/2	.020	25 ga.	.112	1.34
1/2	.032	21 ga.	.174	2.09
1/2	.049	18 ga.	.257	3.08
1/2	.065	16 ga.	.328	3.94
1/2	.125	1/8	.545	6.54
9/16	.032	21 ga.	.198	2.38
9/16	.035	20 ga.	.215	2.58
9/16	.058	17 ga.	.340	4.08
9/16	.065	16 ga.	.376	4.51
5/8	.020	25 ga.	.140	1.68
5/8	.025	23 ga.	.175	2.10
5/8	.032	21 ga.	.220	2.64
5/8	.035	20 ga.	.239	2.87
5/8	.049	18 ga.	.328	3.94
5/8	.065	16 ga.	.423	5.08
5/8	.083	14 ga.	.523	6.28
5/8	.125	1/8	.726	8.71
11/16	.032	21 ga.	.243	2.92
11/16	.065	16 ga.	.470	5.64
3/4	.028	22 ga.	.234	2.81
3/4	.032	21 ga.	.266	3.19
3/4	.035	20 ga.	.291	3.49
3/4	.049	18 ga.	.399	4.79
3/4	.065	16 ga.	.517	6.20
3/4	.083	14 ga.	.643	7.72
3/4	.120	11 ga.	.879	10.6
3/4	.125	1/8	.907	10.9
13/16	.028	22 ga.	.255	3.06
13/16	.032	21 ga.	.290	3.48
13/16	.065	16 ga.	.562	6.74
13/16	.125	1/8	1.00	12.0
7/8	.035	20 ga.	.342	4.10
7/8	.049	18 ga.	.470	5.64
7/8	.065	16 ga.	.612	7.34
7/8	.109	12 ga.	.973	11.7
7/8	.125	1/8	1.09	13.1
15/16	.032	21 ga.	.337	4.04
15/16	.049	18 ga.	.506	6.07
15/16	.125	1/8	1.18	14.2
1	.032	21 ga.	.360	4.32
1	.049	18 ga.	.541	6.49
1	.065	16 ga.	.706	8.47
1	.091	13 ga.	.950	11.0
1	.125	1/8	1.27	15.2
1-1/16	.125	1/8	1.36	16.2
1-1/8	.032	21 ga.	.406	4.87
1-1/8	.065	16 ga.	.800	9.60
1-1/8	.125	1/8	1.45	17.4
1-3/16	.032	21 ga.	.429	5.15
1-3/16	.065	16 ga.	.847	10.2

DIMENSION "A" INCHES	DIMENSION "t"		POUNDS PER FOOT	POUNDS 12' LENGTH
	IN INCHES	FRACTION OR STUBS' GAUGE		
1-3/16	.125	1/8	1.55	18.6
1-1/4	.032	21 ga.	.453	5.44
1-1/4	.035	20 ga.	.494	5.93
1-1/4	.049	18 ga.	.684	8.21
1-1/4	.065	16 ga.	.895	10.7
1-1/4	.125	1/8	1.63	19.6
1-5/16	.065	16 ga.	.942	11.3
1-5/16	.125	1/8	1.73	20.8
1-3/8	.028	22 ga.	.438	5.26
1-3/8	.032	21 ga.	.499	5.99
1-3/8	.049	18 ga.	.755	9.06
1-3/8	.065	16 ga.	.992	11.9
1-3/8	.120	11 ga.	1.75	21.0
1-3/8	.125	1/8	1.81	21.7
1-7/16	.028	22 ga.	.459	5.51
1-7/16	.125	1/8	1.91	22.9
1-1/2	.032	21 ga.	.546	6.55
1-1/2	.035	20 ga.	.595	7.14
1-1/2	.049	18 ga.	.826	9.91
1-1/2	.065	16 ga.	1.09	13.1
1-1/2	.094	13 ga.	1.49	17.9
1-1/2	.125	1/8	1.99	23.9
1-9/16	.032	21 ga.	.547	6.56
1-9/16	.065	16 ga.	1.12	13.4
1-9/16	.095	13 ga.	1.61	19.3
1-5/8	.032	21 ga.	.592	7.10
1-5/8	.065	16 ga.	1.17	14.0
1-5/8	.125	1/8	2.18	26.2
1-3/4	.032	21 ga.	.636	7.66
1-3/4	.035	20 ga.	.697	8.36
1-3/4	.040	19 ga.	.795	9.54
1-3/4	.049	18 ga.	.964	11.6
1-3/4	.065	16 ga.	1.27	15.2
1-3/4	.125	1/8	2.36	28.3
1-3/4	.187	3/16	3.40	40.8
1-7/8	.028	22 ga.	.601	7.21
1-7/8	.032	21 ga.	.685	8.22
1-7/8	.065	16 ga.	1.36	16.3
1-7/8	.125	1/8	2.58	31.0
2	.035	20 ga.	.798	9.58
2	.049	18 ga.	1.11	13.3
2	.065	16 ga.	1.46	17.5
2	.125	1/8	2.72	32.6
2	.250	1/4	5.08	61.0
2-1/16	.032	21 ga.	.756	9.07
2-1/8	.065	16 ga.	1.55	18.6
2-1/8	.125	1/8	2.89	34.7
2-1/4	.032	21 ga.	.821	9.85
2-1/4	.065	16 ga.	1.64	19.7
2-1/4	.125	1/8	3.08	37.0
2-1/4	.250	1/4	5.81	69.7
2-3/8	.032	21 ga.	.868	10.4
2-3/8	.065	16 ga.	1.74	20.9
2-3/8	.125	1/8	3.26	39.1
2-1/2	.035	20 ga.	1.00	12.0
2-1/2	.065	16 ga.	1.83	22.0
2-1/2	.092	13 ga.	2.55	30.6
2-1/2	.125	1/8	3.44	41.3
2-1/2	.250	1/4	6.53	78.4
2-5/8	.065	16 ga.	1.93	23.2
2-3/4	.065	16 ga.	2.02	24.2
2-3/4	.125	1/8	3.82	45.8
3	.032	21 ga.	1.10	13.2
3	.065	16 ga.	2.21	26.5
3	.125	1/8	4.18	50.2
3	.250	1/4	7.98	95.8
3-1/8	.060	-	2.13	25.6
3-1/4	.065	16 ga.	2.40	28.8
3-1/4	.125	1/8	4.54	54.5
3-1/4	.250	1/4	8.71	105.
3-1/2	.065	16 ga.	2.58	31.0
3-1/2	.125	1/8	4.90	58.8
3-1/2	.250	1/4	9.43	113.
3-5/8	.0625	1/16	2.67	32.0
3-3/4	.065	16 ga.	2.77	33.2
3-3/4	.125	1/8	5.26	63.5
4	.125	1/8	5.63	67.6
4	.250	1/4	10.9	131.
4-1/8	.0625	1/16	3.06	36.7
4-1/4	.125	1/8	5.99	71.9

DIMENSION "A" INCHES	DIMENSION "t"		POUNDS PER FOOT	POUNDS 12' LENGTH
	IN INCHES	FRACTION OR STUBS' GAUGE		
4-1/2	.125	1/8	6.35	76.2
4-1/2	.250	1/4	12.4	149.
4-3/4	.125	1/8	6.71	80.5
5	.0625	1/16	3.69	44.3
5	.065	16 ga.	3.73	44.8
5	.125	1/8	7.08	85.0
5	.250	1/4	13.8	166.
5-1/4	.125	1/8	7.44	89.3
5-1/2	.125	1/8	7.80	93.6
5-1/2	.250	1/4	15.3	184.
5-3/4	.125	1/8	8.17	98.0
6	.125	1/8	8.53	102.
6	.250	1/4	16.7	200.
6-1/4	.125	1/8	8.89	107.
6-1/2	.250	1/4	18.1	217.
7	.250	1/4	19.6	235.
7-1/4	.125	1/8	10.4	125.
7-1/2	.250	1/4	21.1	253.
8	.250	1/4	22.5	270.
8-1/4	.125	1/8	11.8	142.
8-1/2	.125	1/8	12.2	146.
8-1/2	.250	1/4	24.0	288.
9-1/4	.125	1/8	13.2	158.
9-1/2	.250	1/4	26.9	323.
10	.250	1/4	28.4	341.
10-1/4	.125	1/8	14.7	176.
10-1/2	.250	1/4	29.8	358.
12-1/4	.125	1/8	17.5	210.
12-5/16	.156	5/32	21.8	262.
12-3/8	.187	3/16	26.5	318.
12-3/4	.375	3/8	53.7	644.

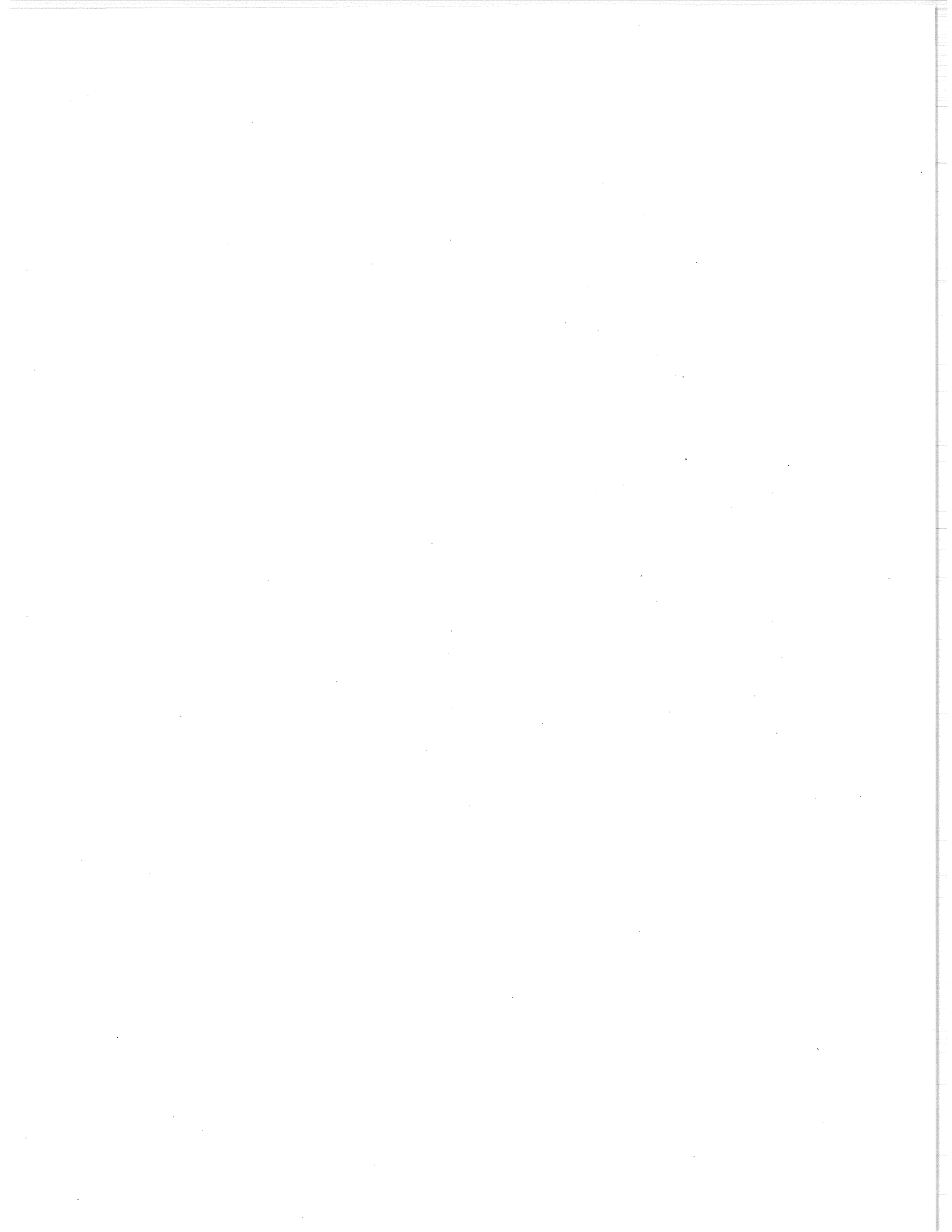

MATERIAL NAMES:

The standard used at Tek for naming parts is H6 (Cataloging Handbook). In some cases, the ASTM uses different names than H6. In such cases the H6 name will be used.

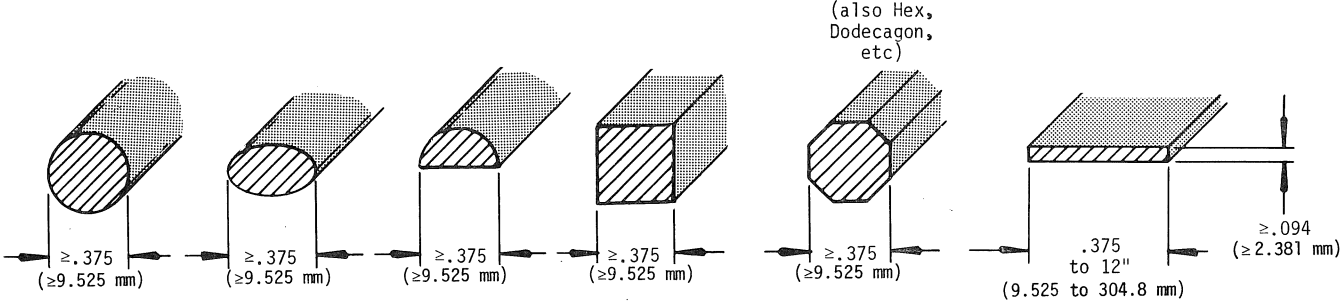
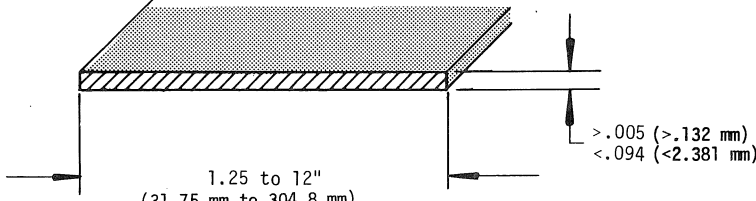
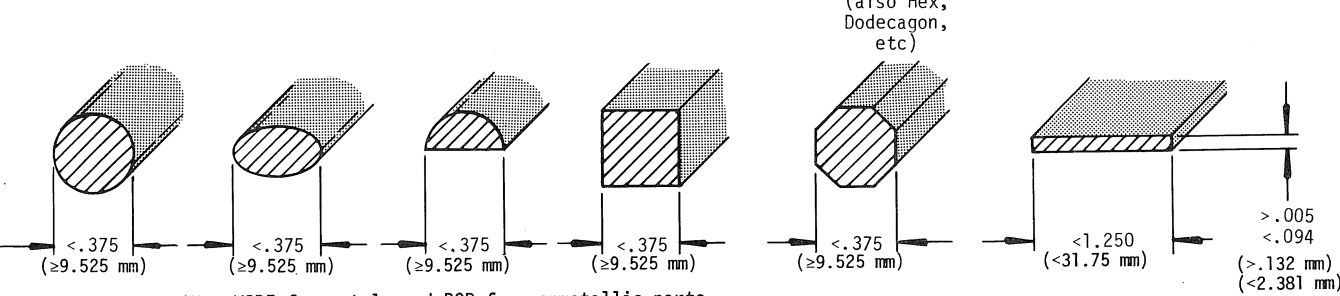
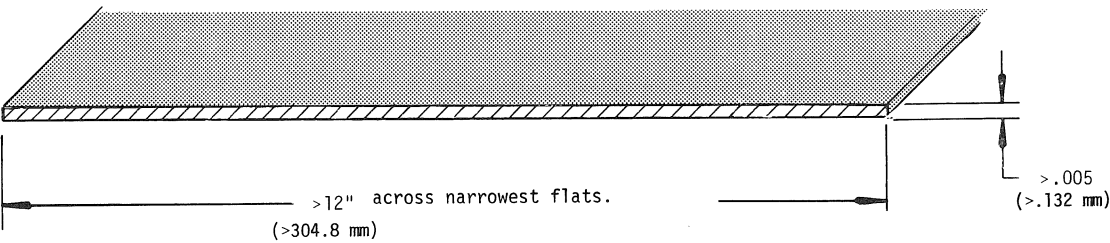
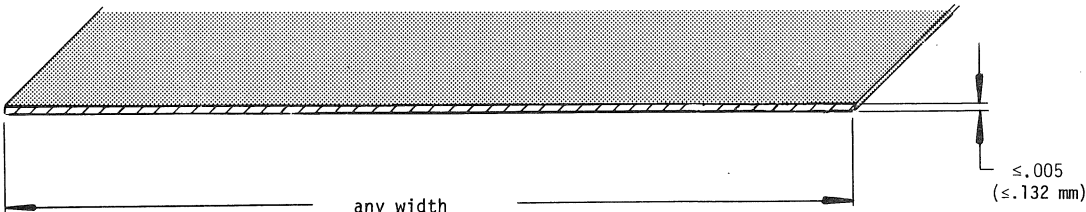
NAME	SHAPE
BAR	 <p>(also Hex, Dodecagon, etc)</p> <p>≥.375 (≥9.525 mm)</p> <p>≥.375 (≥9.525 mm)</p> <p>≥.375 (≥9.525 mm)</p> <p>≥.375 (≥9.525 mm)</p> <p>≥.375 (≥9.525 mm)</p> <p>≥.375 (≥9.525 mm)</p> <p>.375 to 12" (9.525 to 304.8 mm)</p> <p>≥.094 (≥2.381 mm)</p>
ROD	DO NOT USE FOR METALS (Deleted from H6)
STRIP	 <p>1.25 to 12" (31.75 mm to 304.8 mm)</p> <p>>.005 (>.132 mm) <.094 (<2.381 mm)</p>
*WIRE & *ROD	 <p>(also Hex, Dodecagon, etc)</p> <p><.375 (≥9.525 mm)</p> <p><.375 (≥9.525 mm)</p> <p><.375 (≥9.525 mm)</p> <p><.375 (≥9.525 mm)</p> <p><.375 (≥9.525 mm)</p> <p><.375 (≥9.525 mm)</p> <p><1.250 (<31.75 mm)</p> <p>>.005 (>.132 mm) <.094 (<2.381 mm)</p> <p>*Use WIRE for metal, and ROD for nonmetallic parts.</p>
SHEET	 <p>>12" across narrowest flats. (>304.8 mm)</p> <p>>.005 (>.132 mm)</p>
FOIL & **FILM	 <p>any width</p> <p>≤.005 (≤.132 mm)</p> <p>Use FOIL for metal, and FILM for nonmetallic parts.</p>

Some materials do not yet have specifications and may change without notice until the spec is finished. Also, some are exclusively used by one department and may be changed without notice by them.

COPPER BERYLLIUM

SECTION 9

TABLE OF CONTENTS

	PAGE(S)
WIRE	9-2
BAR	9-2
FOIL	9-2 & 9-3
STRIP	9-3
FINGER STOCK	9-3
ASTM B194 SPECIFICATION	9-6
ASTM B196 SPECIFICATION	9-7
ASTM B197 SPECIFICATION	9-7
ASTM B643 SPECIFICATION	9-8
ASTM B248 (TOLERANCES)	12-10 & 12-11
ASTM B249 (TOLERANCES)	12-12 & 12-13
ASTM B250 (TOLERANCES)	12-14
NOTES	9-4
CROSS REFERENCE INDEX	9-5
WEIGHT (LBS PER FOOT)	9-9

TEK STANDARDS PERTAINING TO MATERIALS

062-1702-00	Welding, Soldering & Brazing	D-100	Die Casting & Molding Standards
062-1703-00	Finishes, Glossary of Terms		
062-1713-00	Drafting, Aluminum Extrusions	H Series	Tooling Standards
062-1718-00	Finish Quality, Cosmetic		
062-2845-00	Mechanically Applied Finishes		
062-2848-00	Bend Allowance & Deduction	062-5818-01	Aluminum (M150)
062-2850-00	Finish, Surface Texture	M-200	Brass
062-2854-00	Finishes, Chemical & Electromechanical	M-250	Copper
062-2856-00	Non-Additive Finishes for Brass, Copper & Copper Alloys	M-300	Copper-Beryllium
062-2860-00	Finishes, Anodized	M-350	Beryllium-Nickel
062-2863-00	Zinc Die Cast Finishes, Chromate Conversion Coatings	M-400	Phosphor-Bronze
062-2868-00	Finish, Etch Chromate & Lacquer (On Aluminum)	M-450	Steel
062-2868-01	Chromate Conversion Coating for Al Die Casting Alloy 3431	M-500	Stainless Steel
062-2871-00	Finish, Passivating	M-550	Magnetic Shielding Materials (Iron-Nickel & Nickel-Silver)
062-5818-00	General Information about Bulk Raw Materials	M-600	Copper-Nickel-Zinc

COST CODE

(CC COLUMN)

CODE	A	B	C	D	E	F	G	H	I	J	K	L	M	N	O
≈ VALUE with +	.75¢	2¢	3.75¢	6¢	10¢	18¢	35¢	60¢	\$1	\$2	\$3.75	\$6	\$10	\$18	\$35+
≈ VALUE no suffix	.5¢	1.5¢	3¢	5¢	8¢	15¢	25¢	50¢	75¢	\$1.50	\$3	\$5	\$8	\$15	\$25
≈ VALUE with -	.2¢	1.25¢	2.5¢	4.25¢	7¢	13¢	22¢	40¢	65¢	\$1.25	\$2.50	\$4.25	\$7	\$13	\$22

NOTE: Costs may vary from order to order due to order quantities, vendor, etc.

COPPER BERYLLIUM (CONT)

WIRE

SIZE	ALLOY Δ	TEMPER	SPECIFICATION* (ASTM)	TOLERANCE** (ASTM)	PART NUMBER	CC	OTHER
.006 x .125	C17200	Full Hard	B194	B248	258-0381-01	oz I-	
.006 x .156	C17200	Full Hard	B194	B248	258-0381-00	oz I-	
.006 x 1.000	C17200	Annealed	B194	B248	251-0401-00	1b N-	
.007 x .187	C17200	One qtr Hard	B194	B248	251-0465-01	ft E	
.007 x .500 + .010 - .000	C17200	One qtr Hard	B194	B248	251-0465-03	oz H+	
.007 x .531	C17200	One half Hard	B194	B248	258-0374-02	1b M	
.007 x .640 + .010 + .000	C17200	One qtr Hard	B194	B248	251-0465-02	oz I+	
.008 x .125	C17200	Hard	B194	B248	258-0382-01	oz I-	
.008 x .156	C17200	Hard	B194	B248	258-0382-00	oz H+	
.010 x .125	C17200	Hard	B194	B248	258-0383-01	oz H+	
.010 x 1.093	C17200	Hard	B194	B248	258-0383-03		
.010 x .156	C17200	Hard	B194	B248	258-0383-00	oz H+	
.010 x .844	C17200	One qtr Hard	B194	B248	251-0462-05	oz H	
.010 x 1.000	C17200	One qtr Hard	B194	B248	251-0462-02	oz H	
.0126 x .500	C17200	One qtr Hard	B194	B248	251-0378-03	1b M	
.0126 x 1.125	C17200	One qtr Hard	B194	B248	251-0378-02	1b M	
.0150 x .312 + .000 - .005	C17200	One qtr Hard	B194	B248	251-0439-01	1b M+	
.0150 x .450	C17200	One half Hard	B194	B248	258-0528-00	1b M+	
.018 x .200	C17200	One qtr Hard	B194	B248	258-0378-02	1b M	
.020 x .312	C17200	One qtr Hard	B194	B248	251-0412-01	1b M-	
.020 x .625	C17200	One qtr Hard	B194	B248	251-0412-00	1b M	
.020 x 1.000	C17200	One qtr Hard	B194	B248	251-0412-02	1b M	
.025 x .438	C17200	One half Hard	B194	B248	251-0400-00	1b M	
.025 x .730	C17200	One half Hard	B194	B248	251-0400-01	1b M	
.032 x .375	C17200	Annealed	B194	B248	251-0406-00	1b L+	
.040 dia	C17200	One qtr Hard	B197	B250	251-0432-00	oz I+	Silver Clad
.058 x .185	C17200	One half Hard	B194	B248	258-0423-00	1b N-	
.062 dia	C17300	One half Hard	B196	B249	258-0442-00	1b N-	
.094 dia	C17300	One half Hard	B196	B249	251-0493-00	1b N	
.156 dia	C17300	One half Hard	B196	B249	251-0471-00	1b M-	
.188 dia	C17300	One half Hard	B196	B249	258-0352-00	1b M+	
.250 dia	C17300	One half Hard	B196	B249	251-0478-00	1b M+	
.250 hex	C17300	Hard	B196	B249	258-0403-00	1b M	
.312 dia	C17300	One half Hard	B196	B249	258-0420-00	1b M	

BAR

SIZE	ALLOY Δ	TEMPER	SPECIFICATION* (ASTM)	TOLERANCE** (ASTM)	PART NUMBER	CC	OTHER
.375 dia	C17300	One half Hard	B196	B249	251-0498-00	1b K+	
.688 dia	C17300	One half Hard	B196	B249	258-0436-00	1b M-	

FOIL

SIZE	ALLOY	TEMPER	SPECIFICATION* (ASTM)	TOLERANCE** (ASTM)	PART NUMBER	CC	OTHER
.002 x 2.250	C17200	One qtr Hard	B194	B248	258-0485-00	ft E+	
.002 x 2.500	C17200	One qtr Hard	B194	B248	258-0485-03	1b N	
.002 x 4.125	C17200	One qtr Hard	B194	B248	258-0485-02	1b N	
.002 x 6.000	C17200	One half Hard	B194	B248	258-0471-00	1b N	
.003 ± .002 x 1.000 ± .005	C17200	One half Hard	B194	B248	258-0384-00	oz H	Tensile strength 85/100 ksi
.003 ± .0004 x 6.000	C17200	One half Hard	B194	B248	258-0384-01	1b M+	Tensile strength 85/100 ksi
.003 x 6.000	C17200	One qtr Hard	B194	B248	258-0507-00	1b I+	
.003 x 6.000	C17200	Hard	B194	B248	251-0487-00	1b M+	
.004 x .125	C17200	One qtr Hard	B194	B248	251-0468-00	oz J	
.004 x .200	C17200	One qtr Hard	B194	B248	251-0468-03	1b N+	
.004 x .438	C17200	One qtr Hard	B194	B248	251-0468-02	oz H	
.004 ± .0002 x .450	C17200	Extra Hard	B194	B248	258-0416-00	ft D	Tensile strength 160/175 ksi Preplate CD Flash .00002
.004 x .648	C17200	Annealed	B194	B248	258-0414-01	1b N-	
.004 x .850 + .000 + .005	C17200	Hard	B194	B248	258-0463-01	1b M+	
.004 x 1.000	C17200	Annealed	B194	B248	258-0414-00	1b M-	
.004 x 6.000	C17200	Hard	B194	B248	258-0463-00	1b M+	

* MECHANICAL PROPERTIES CAN BE FOUND ON PAGES 9-6 THRU 9-8.
 ** FOR TOLERANCES, SEE PAGES 12-12 THRU 12-23.
 Δ BE CU 33/34-25 OR M25 IS THE SAME AS C17300

COPPER BERYLLIUM (CONT)

FOIL (CONT)

SIZE	ALLOY	TEMPER	SPECIFICATION* (ASTM)	TOLERANCE** (ASTM)	PART NUMBER	CC	OTHER
.004 x 6.000	C17200	One qtr Hard	B194	B248	251-0468-01	oz I	Cd Plate
.004 ± .002 x 6.750	C17200	Extra Hard	B194	B248	258-0416-01	1b N-	
.005 x .150	C17200	One qtr Hard	B194	B248	251-0451-06	oz I+	
.005 x 1.000	C17200	One half Hard	B194	B248	251-0490-03	ft F	
.005 x .500	C17200	One qtr Hard	B194	B248	251-0451-01	oz I	
.005 x 1.062	C17200	One qtr Hard	B194	B248	251-0451-02	1b L+	
.005 x ± .001 x 2.000	C17200	One qtr Hard	B194	B248	251-0451-03	1b L	
.005 x 6.000	C17200	One qtr Hard	B194	B248	251-0451-00	oz I+	
.005 x 6.000	C17200	One half Hard	B194	B248	251-0490-00	ft J+	
.005 x 6.000	C17200	Hard	B194	B248	258-0510-00	1b N+	

STRIP

SIZE	ALLOY	TEMPER	SPECIFICATION* (ASTM)	TOLERANCE** (ASTM)	PART NUMBER	CC	OTHER
.006 ± .003 x 6.000	C17200	Hard	B194	B248	258-0464-00	1b L+	Tensile strength 135/150 ksi
.006 x 6.000	C17200	Annealed	B194	B248	251-0401-01	1b N+	
.007 x 1.328	C17200	One qtr Hard	B194	B248	251-0465-05	1b M+	
.007 x 6.000	C17200	One half Hard	B194	B248	258-0374-03	1b M-	
.007 x 6.000 to 6.500	C17200	One qtr Hard	B194	B248	251-0465-00	1b M-	
.007 ± .002 x 6.000	C17200	Hard	B194	B248	258-0396-01	oz H+	
.008 x 6.000	C17200	Hard	B194	B248	258-0382-02	1b M	
.010 x 1.375	C17200	One qtr Hard	B194	B248	251-0462-03	oz H	
.010 x 1.812	C17200	One qtr Hard	B194	B248	251-0462-01	oz H	
.010 x 6.000	C17200	One qtr Hard	B194	B248	251-0462-00	1b M	
.010 x 6.000	C17200	Hard	B194	B248	258-0383-02	1b M	
.0126 x 1.500	C17200	One qtr Hard	B194	B248	251-0378-01	1b M	
.0126 x 6.000	C17200	One qtr Hard	B194	B248	251-0378-04	1b M	
.0126 x 8.000	C17200	One qtr Hard	B194	B248	251-0378-07	1b N-	
.015 x 2.530	C17200	One qtr Hard	B194	B248	251-0439-02	1b M+	
.015 x 6.000	C17200	One qtr Hard	B194	B248	251-0439-00	1b M+	
.015 x 6.000	C17200	One half Hard	B194	B248	258-0421-01	1b M	
.018 x 6.000	C17200	One qtr Hard	B194	B248	258-0378-01	1b M	
.020 x 1.844	C17200	One qtr Hard	B194	B248	251-0412-06	1b M	
.020 x 2.750	C17200	One qtr Hard	B194	B248	251-0412-03	1b L-	
.020 x 6.000	C17200	Annealed	B194	B248	258-0525-00	1b N	
.020 x 6.000	C17200	One qtr Hard	B194	B248	251-0412-04	1b M	
.025 x 1.250	C17200	One qtr Hard	B194	B248	251-0442-02	1b M	
.025 x 1.625 ± .015	C17200	One qtr Hard	B194	B248	251-0442-01	1b M	
.025 x 2.500	C17200	One qtr Hard	B194	B248	258-0468-00	1b M	
.025 x 6.000	C17200	One qtr Hard	B194	B248	251-0442-00	1b L+	
.032 x 6.000 to 6.500	C17200	One qtr Hard	B194	B248	258-0325-00	1b M	

TUBE

SIZE	ALLOY Δ	TEMPER	SPECIFICATION (ASTM)	TOLERANCE (ASTM)	PART NUMBER	CC	OTHER
.040 ID x .080 OD	C17300	One half Hard Seamless	B643	(See Page 9-8)	258-0529-00	ft J-	

COST CODE

(CC COLUMN)

.004 x 16.000 Silver Plate Finger Stock 251-0369-00 CC: in/D+

CODE	≈ VALUE with -	≈ VALUE no suffix	≈ VALUE with +
A	.2¢	.5¢	.75¢
B	1.25¢	1.5¢	2¢
C	2.5¢	3¢	3.75¢
D	4.25¢	5¢	6¢
E	7¢	8¢	10¢
F	13¢	15¢	18¢
G	22¢	25¢	35¢
H	40¢	50¢	60¢
I	65¢	75¢	\$1
J	\$1.25	\$1.50	\$2
K	\$2.50	\$3	\$3.75
L	\$4.25	\$5	\$6
M	\$7	\$8	\$10
N	\$13	\$15	\$18
O	\$22	\$25	\$35+

COPPER-BERYLLIUM, BERYLLIUM-NICKEL ALLOY GUIDE

A guide for the selection and use of beryllium-copper and beryllium-nickel alloys is available from the Metallurgical Lab. These two alloys are among the most widely used at Tek for producing springs, contact switches, retainer clips and other similar components.

The guidelines were written by Kwaku Mensah, and describe the electrical and mechanical properties of the alloys, as well as the advantages and disadvantages associated with each. Selection factors are based on electrical and thermal conductivity, yield strength, corrosion and wear resistance, fatigue and impact strength and other criteria.

To make the best choice of materials, it is important that designers be aware of the unique properties of these alloys. If you would like a copy of the selection guidelines, send your request to the Metallurgical Lab (38-314).

NOTES

9

COST CODE (CC COLUMN)

CODE	≈ VALUE with -	≈ VALUE no suffix	≈ VALUE with +
A	.2¢	.5¢	.75¢
B	1.25¢	1.5¢	2¢
C	2.5¢	3¢	3.75¢
D	4.25¢	5¢	6¢
E	7¢	8¢	10¢
F	13¢	15¢	18¢
G	22¢	25¢	35¢
H	40¢	50¢	60¢
I	65¢	75¢	\$1
J	\$1.25	\$1.50	\$2
K	\$2.50	\$3	\$3.75
L	\$4.25	\$5	\$6
M	\$7	\$8	\$10
N	\$13	\$15	\$18
O	\$22	\$25	\$35+

NOTE: Costs may vary from order to order
due to order quantities, vendor, etc.

CROSS REFERENCE INDEX

COPPER BERYLLIUM

PART NUMBER	DESCRIPTION	SIZE	PAGE NO.	STATUS ^{§§}
251-0369-00	Finger Stock	.004 x 16.000	9-3	CS
251-0378-01	Strip	.0126 x 1.500	9-3	CR
251-0378-02	Wire	.0126 x 1.125	9-2	CR
251-0378-03	Wire	.0126 x .500	9-2	CR
251-0378-04	Strip	.0126 x 6.000	9-3	CR
251-0378-06	Wire	.0126 x .800		DL
251-0378-07	Strip	.0126 x 8.000	9-3	CR
251-0400-00	Wire	.025 x .438	9-2	CR
251-0400-01	Wire	.025 x .730	9-2	CR
251-0400-02	Strip	.025 x 9.000		DL
251-0401-00	Wire	.006 x 1.000	9-2	CR
251-0401-01	Strip	.006 x 6.000	9-3	CR
251-0406-00	Wire	.032 x .375	9-2	CR
251-0406-01	Strip	.032 x 1.312		OB
251-0412-00	Wire	.020 x .625	9-2	CR
251-0412-01	Wire	.020 x .312	9-2	CR
251-0412-02	Wire	.020 x 1.000	9-2	CR
251-0412-03	Strip	.020 x 2.750	9-3	CR
251-0412-04	Strip	.020 x 6.000	9-3	CR
251-0412-06	Strip	.020 x 1.844	9-3	CR
251-0432-00	Wire	.040 dia	9-3	CR
251-0432-01	Wire	.040 dia		DL
251-0439-00	Strip	.015 x 6.000	9-3	CR
251-0439-01	Wire	.015 x .312	9-2	CR
251-0439-02	Strip	.015 x 2.530	9-3	CR
251-0442-00	Strip	.025 x 6.000	9-3	CR
251-0442-01	Strip	.025 x 1.625	9-3	CR
251-0442-02	Strip	.025 x 1.250	9-3	CR
251-0447-00	Wire	.0179 x .562		OB
251-0451-00	Foil	.005 x 6.000	9-3	CR
251-0451-01	Foil	.005 x .500	9-3	CR
251-0451-02	Foil	.005 x 1.062	9-3	OB
251-0451-03	Foil	.005 x 2.000	9-3	OB
251-0451-04	Foil	.005 x .400		CS
251-0451-06	Foil	.005 x .150	9-3	CR
251-0462-00	Strip	.010 x 6.000	9-3	CR
251-0462-01	Strip	.010 x 1.812	9-3	CR
251-0462-02	Wire	.010 x 1.000	9-2	CR
251-0462-03	Strip	.010 x 1.375	9-3	CR
251-0462-05	Wire	.010 x .844	9-2	CR
251-0465-00	Strip	.007 x 6.000	9-3	CR
251-0465-01	Wire	.007 x .187	9-2	CR
251-0465-02	Wire	.007 x .640	9-2	CR
251-0465-03	Wire	.007 x .500	9-2	CR
251-0465-05	Strip	.007 x 1.328	9-3	CR
251-0468-00	Foil	.004 x .125	9-2	OB
251-0468-01	Foil	.004 x 6.000	9-3	CR
251-0468-02	Foil	.004 x .438	9-2	OB
251-0468-03	Foil	.004 x .200	9-2	CR
251-0471-00	Wire	.156 dia	9-2	CR
251-0478-00	Wire	.250 dia	9-2	CR
251-0487-00	Foil	.003 x 6.000	9-2	CR
251-0490-00	Foil	.005 x 6.000	9-3	CR
251-0490-01	Foil	.005 x 1.250		DL
251-0490-03	Foil	.005 x 1.000	9-3	PP
251-0493-00	Wire	.094 dia	9-2	CR
251-0498-00	Bar	.375 dia	9-2	CS
251-0525-00	Strip	.020 x 6.000		NP
258-0325-00	Strip	.032 x 6.000	9-3	CR
258-0352-00	Wire	.188 dia	9-2	CR
258-0374-00	Wire	.007 x 1.000		DL
258-0374-01	Wire	.007 x .250		OT
258-0374-02	Wire	.007 x .531	9-2	CR
258-0374-03	Strip	.007 x 6.000	9-3	CR
258-0378-01	Strip	.018 x 6.000	9-3	CR
258-0378-02	Wire	.018 x .200	9-2	CR
258-0381-00	Wire	.006 x .156	9-2	CR
258-0381-01	Wire	.006 x .125	9-2	CR
258-0381-02	Wire	.006 x .180		DL
258-0382-00	Wire	.008 x .156	9-2	CR
258-0382-01	Wire	.008 x .125	9-2	CR
258-0382-02	Strip	.008 x 6.000	9-3	CR
258-0383-00	Wire	.010 x .156	9-2	CR
258-0383-01	Wire	.010 x .125	9-2	CR
258-0383-02	Strip	.010 x 6.000	9-3	CR

PART NUMBER	DESCRIPTION	SIZE	PAGE NO.	STATUS ^{§§}
258-0383-03	Wire	.010 x 1.093	9-2	CR
258-0384-00	Foil	.003 x 1.000	9-2	CR
258-0384-01	Foil	.003 x 6.000	9-2	CR
258-0396-00	Wire	.007 x 1.000		OB
258-0396-01	Strip	.007 x 6.000	9-3	CR
258-0399-00	Strip	.006 x 1.375		DL
258-0399-01	Wire	.006 x .640		CS
258-0403-00	Wire	.250 hex	9-2	CR
258-0414-00	Foil	.004 x 1.000	9-2	CS
258-0414-01	Foil	.004 x .648	9-2	CR
258-0416-00	Foil	.004 x .450	9-2	CR
258-0416-01	Foil	.004 x 6.750	9-3	CR
258-0420-00	Wire	.312 dia	9-2	CR
258-0421-00	Wire	.015 x .125		DL
258-0421-01	Strip	.015 x 6.000	9-3	CR
258-0421-02	Foil	.015 x 2.530		NP
258-0423-00	Wire	.058 x .185	9-2	CR
258-0433-00	Wire	.010 x .400		DL
258-0436-00	Bar	.688 dia	9-2	CR
258-0442-00	Wire	.062 dia	9-2	CR
258-0463-00	Foil	.004 x 6.000	9-2	CR
258-0463-01	Foil	.004 x .850	9-2	CR
258-0464-00	Strip	.006 x 6.000	9-3	CR
258-0468-00	Strip	.025 x 2.500	9-3	CR
258-0471-00	Strip	.002 x 6.000	9-2	CR
258-0484-00	Wire	.006 x 1.125		DL
258-0485-00	Foil	.002 x 2.250	9-2	CR
258-0485-01	Foil	.002 x 2.000		DL
258-0485-02	Foil	.002 x 4.125	9-2	CR
258-0485-03	Foil	.002 x 2.500	9-2	CR
258-0492-00	Foil	.003 x .650		DL
258-0507-00	Foil	.003 x 6.000	9-2	CR
258-0510-00	Foil	.005 x 6.000	9-3	CR
258-0525-00	Strip	.020 x 6.000	9-3	CR
258-0528-00	Wire	.015 x .450	9-2	CR
258-0529-00	Tube	.040 ID x .080 OD	9-3	PP

§§ STATUS CODES

CR	Current Production
EN	Engineering
PP	Pre-Production
CS	Customer Service
NP	Non-Production
DL	Deleted
OB	Obsolete Instrument
CM	Custom Mod Instrument
DS	Digital Systems
OT	Obsolescent Instrument
MP	Modified Part
LR	Last Supply Current
LS	Last Supply Customer Service
VN	Vendor
TC	Tequipment Current Production
IN	International
SC	Sony/Tek Current Production

THE STATUS IN THIS CATALOG WAS CORRECT AT THE TIME IT WAS PUBLISHED, BUT IT IS SUBJECT TO CHANGE.

§ TO USE A PART WITH THIS STATUS ON A NEW INSTRUMENT REQUIRES THAT A NEW PURCHASED PART INITIATION FORM (PPIF) BE INITIATED.

(A GLOSSARY OF TERMS FOR THESE STATUS CODES CAN BE FOUND ON PAGE 0-10).

COPPER BERYLLIUM (CONT)

ASTM B194

MECHANICAL PROPERTY REQUIREMENTS FOR MATERIAL AS SUPPLIED COMMERCIALY

TEMPER		TENSILE STRENGTH *KSI	ELONGATION IN 2 IN. OR 50 MM, MIN, %	ROCKWELL HARDNESS		
STANDARD DESIGNATION	FORMER DESIGNATION			B SCALE	30T SCALE	15T SCALE
TB00	Solution-heat-treated (A)	60-78	35	45-78	46-67	75-85
TD01	Qtr-Hard	75-88	10	68-90	62-75	83-39
TD02	Half-Hard	85-100	5	88-96	74-79	88-91
TD04	Hard	100-120	2	96-102	79-83	91-94

MECHANICAL PROPERTY REQUIREMENTS AFTER PRECIPITATION HEAT TREATMENT. ALLOY NUMBER C17000.

TEMPER		TENSILE STRENGTH, *KSI ²	YIELD STRENGTH	ROCKWELL HARDNESS ¹ MIN		
STANDARD DESIGNATION	FORMER DESIGNATION			C SCALE	30N SCALE	15N SCALE
TF00	Annealed	150 - 180	130	33	53	76.5
TH01	Qtr-Hard	160 - 190	135	35	55	77
TH02	Half-Hard	170 - 200	145	37	57	78.5
TH04	Hard	180 - 210	155	39	59	79.5

MECHANICAL PROPERTY REQUIREMENTS AFTER PRECIPITATION HEAT TREATMENT. ALLOY NUMBER C17200.

TEMPER		TENSILE STRENGTH, *KSI ²	YIELD STRENGTH KSI*	ROCKWELL HARDNESS ¹ MIN		
STANDARD DESIGNATION	FORMER DESIGNATION			C SCALE	30N SCALE	15N SCALE
TF00	Annealed	165 - 195	140	36	56	78
TH01	Qtr-Hard	175 - 205	150	38	58	79
TH02	Half-Hard	185 - 215	160	39	59	79.5
TH04	Hard	190 - 220	165	40	60	80

¹ THICKNESS OF MATERIAL: C SCALE .032 IN AND OVER
30N SCALE .02 to .032 IN
15N SCALE .015 TO .02 IN

² THE UPPER LIMIT IN THE TENSILE STRENGTH COLUMN APPLIES TO MATERIAL THICKER THAN .02 INCH.

ASTM B196

TENSILE STRENGTH AND HARDNESS REQUIREMENTS AFTER PRECIPITATION HEAT TREATMENT. ALLOY NUMBER C17000.

TEMPER	DIA OR DISTANCE BETWEEN PARALLEL SURFACES, INCHES	TNSL STRENGTH, *KSI	ROCKWELL HARDNESS C SCALE
SOLUTION HEAT TREATED	ALL SIZES	150 - 190	32-39
HARD	UP TO .375	175 - 210	36-41
	OVER .375 TO 1	170 - 205	35-40
	OVER 1	165 - 200	34-39

TENSILE STRENGTH AND HARDNESS REQUIREMENTS AFTER PRECIPITATION HEAT TREATMENT. ALLOYS NUMBERS C17200 & C17300.

TEMPER	DIA OR DISTANCE BETWEEN PARALLEL SURFACES, INCHES	TNSL STRENGTH, *KSI	ROCKWELL HARDNESS C SCALE
SOLUTION HEAT TREATED	ALL SIZES	165 - 200	36-40
HARD	UP TO .375	185 - 225	39-45
	OVER .375 TO L	180 - 220	38-44
	OVER 1	175 - 215	37-43

The dimensions and tolerances for material covered by these Specifications (B194, B196 & B197) can be found in Specification ASTM B248, B249 & B250⁺⁺. (See pages 12-12 thru 12-21).

⁺⁺The full text of this ASTM is available for review at 78-567, or, for more information, call Norma at Ext. 2577, or Comp. Eval., Bella Geotina, Ext. 2315.

COPPER BERYLLIUM (CONT)

ASTM B197

TENSILE STRENGTH REQUIREMENTS FOR ROUND, OCTAGONAL, HEXAGONAL, AND SQUARE MATERIAL SUPPLIED COMMERCIALY.

TEMPER	TNSL STRENGTH, *KSI
ANNEALED	58 -TO 78
QTR-HARD	90 TO 115
HALF-HARD	110 TO 135
THREE- ¹ QTR-HARD	130 TO 155

MECHANICAL PROPERTY REQUIREMENTS FOR RECTANGULAR MATERIAL AFTER PRECIPITATION HEAT TREATMENT.

TEMPER	MINIMUM TENSILE STRENGTH, *KSI	ROCKWELL HARDNESS ³		
		C SCALE MIN	30N SCALE MIN	15N SCALE MIN
ANNEALED	165 TO 190	36	56	78
QTR-HARD	175 TO 200	38	58	79
HALF-HARD	185 TO 210	39	59	79.5
HARD	190 TO 215	40	60	80

MECHANICAL PROPERTY REQUIREMENTS FOR RECTANGULAR MATERIAL AS SUPPLIED COMMERCIALY.

TEMPER	TNSL STRENGTH, *KSI	ELONGATION IN 2 INCH MIN % ²	ROCKWELL HARDNESS ³		
			B SCALE	30T SCALE	15T SCALE
ANNEALED	60 TO 78	35	45- 78	46-67	75-85
QTR-HARD	75 TO 88	10	68- 90	62-75	83-89
HALF-HARD	85 TO 100	5	88- 96	74-79	88-91
HARD	100 TO 120	2	96-102	79-83	91-94

TENSILE STRENGTH REQUIREMENTS FOR ROUND, HEXAGONAL, OCTAGONAL, AND SQUARE MATERIAL AFTER PRECIPITATION HEAT TREATMENT.

TEMPER BEFORE HARDENING	TNSL STRENGTH, *KSI
ANNEALED	160 TO 190
QUARTER-HARD	175 TO 205
HALF-HARD	185 TO 215
THREE-QTR-HARD	190 TO 230

¹ Three-quarter-hard condition is generally available up to .08 inch dia or distance between parallel surfaces.

² Elongation requirements apply to material .004 inch and thicker.

³ Thickness of material in Rockwell hardness scales:

B scale: .032 in & over C scale: .032 in & over
 30T scale: .02 to .032 inch 30N scale: .02 to .032 inch
 15T scale: .015 to .02 inch 15N scale: .015 to .02 inch

The dimensions and tolerances for material covered by this specification (B197) can be found in Specification ASTM B250 ++ (see pages 12-20 & 12-21).

COPPER BERYLLIUM (CONT)

ASTM B643

MECHANICAL PROPERTY REQUIREMENTS FOR MATERIAL AS SUPPLIED COMMERCIALLY

TENSILE STRENGTH & HARDNESS REQUIREMENTS AFTER PRECIPITATION HEAT TREATMENT¹

TEMPER ³		DIAMETER DISTANCE BETWEEN PARALLEL SURFACES IN (mm)	ROCKWELL ² HARDNESS B SCALE	TENSILE STRENGTH ⁴	
STANDARD DESIGNATION	FORMER DESIGNATION			ksi ⁵	(MPa)
TB00	Solution-heat-treated	3/4 (19.1) & over	45-85	60-85	(410-570)
TD04	Hard	3/4 (19.1) & over	88-103	85-115	(590-800)

TEMPER ³		DIAMETER DISTANCE BETWEEN PARALLEL SURFACES IN (mm)	ROCKWELL ² HARDNESS C SCALE	TENSILE STRENGTH ⁴	
STANDARD DESIGNATION	FORMER DESIGNATION			ksi ⁵	(MPa)
TB00	Solution-heat-treated	3/4 (19.1) & over	36-41	165-190	(1130-1300)
TD04	Hard	3/4 (19.1) & over	37-44	170-215	(1160-1490)

- These values apply to mill products. See 11.3 for exceptions in end products.
- Hardness values shown apply only to direct determinations, not converted values.
- Standard designations defined in Recommended Practice B 601.
- Hardness is the normal commercial acceptance criterion. Mechanical properties apply only when specifically required.
- ksi = 1000 psi.

WALL THICKNESS TOLERANCES -- COLD-WORKED TUBE

NOTE: Maximum deviation at any point--The following tolerances are plus & minus; if tolerances all plus or all minus are desired double the values given.

WALL THICKNESS, IN. (mm)	OUTSIDE DIAMETER, IN. (mm)				
	Over 5/8 to 1 (15.9 to 25.4), incl.	Over 1 to 2 (25.4 to 50.8), incl.	Over 2 to 4 (50.8 to 102), incl.	Over 4 to 7 (102 to 173), incl.	Over 7 to 12 (173 to 305), incl.
Over 0.034 (0.864) to 0.057 (1.45), incl.	0.0045 (0.11)	0.0045 (0.11)	0.0065 (0.17)	0.009 (0.23)	---
Over 0.057 (1.45) to 0.082 (2.08), incl.	0.005 (0.13)	0.005 (0.13)	0.0075 (0.19)	0.010 (0.25)	0.013 (0.33)
Over 0.082 (2.08) to 0.119 (3.02), incl.	0.0065 (0.17)	0.0065 (0.17)	0.009 (0.23)	0.011 (0.28)	0.014 (0.36)
Over 0.119 (3.02) to 0.164 (4.17), incl.	0.007 (0.18)	0.0075 (0.19)	0.010 (0.25)	0.013 (0.33)	0.015 (0.38)
Over 0.164 (4.17) to 0.219 (5.56), incl.	0.009 (0.23)	0.010 (0.25)	0.012 (0.30)	0.015 (0.38)	0.018 (0.46)
Over 0.219 (5.56) to 0.283 (7.19), incl.	0.012 (0.30)	0.017 (0.33)	0.015 (0.38)	0.018 (0.46)	0.020 (0.51)
Over 0.283 (7.19) to 0.379 (9.62), incl.	0.014 (0.36)	*	*	*	*
Over 0.379 (9.62)	*	*	*	*	*

* Percent of the specified wall thickness expressed to the nearest 0.001 in (0.025 mm).

When tube is ordered by outside and inside diameters, the maximum plus and minus deviation of the wall thickness from the nominal at any point shall not exceed the values given in this table by more than 50%.

WALL THICKNESS TOLERANCES -- HOT-WORKED TUBE

NOTE: Maximum deviation at any point--The following tolerances are plus & minus; if tolerances all plus or all minus are desired double the values given.

WALL THICKNESS, IN. (mm)	OUTSIDE DIAMETER, IN (mm)			
	5/8 to 1 (15.9 to 25.4)	Over 1 to 2 (25.4 to 50.8)	Over 2 to 4 (50.8 to 102)	Over 4 (102)
Over 0.125 (3.2) to 0.250 (6.5), incl.	± 0.014 (.36)	± 0.017 (0.43)	± 0.020 (0.51)	± 0.030 (0.76)
Over 0.250 (6.5) to 0.500 (12.7), incl.	± 0.017 (.43)	± 0.023 (0.58)	± 0.032 (0.81)	± 0.053 (1.35)
Over 0.500 (12.7) to 1.000 (25.4), incl.	---	± 0.030 (0.76)	± 0.053 (1.35)	± 0.083 (2.11)
Over 1.000 (25.4)	---	---	± 0.068 (1.73)	± 0.098 (2.49)

When tube is ordered by outside and inside diameters, the maximum plus and minus deviation of the wall thickness from the nominal at any point shall not exceed the values given in this table by more than 50%.

AVERAGE DIAMETER TOLERANCES

SPECIFIED DIAMETER, IN. (mm)	TOLERANCE, PLUS AND MINUS IN. (mm) ¹	
	COLD-WORKED TUBE	HOT-WORKED TUBE
Over 1/2 (12.7) to 3/4 (19.1), incl.	0.003 (0.08)	0.020 (0.51)
Over 3/4 (19.1) to 1 (25.4), incl.	0.006 (0.15)	0.020 (0.51)
Over 1 (25.4) to 2 (50.8), incl.	0.008 (0.20)	0.030 (0.76)
Over 2 (50.8) to 3 (76.2), incl.	0.010 (0.25)	0.040 (1.02)
Over 3 (76.2) to 4 (102), incl.	0.012 (0.30)	0.050 (1.27)
Over 4 (102) to 5 (127), incl.	0.016 (0.41)	0.060 (1.52)
Over 5 (127) to 6 (152), incl.	0.018 (0.46)	0.060 (1.52)
Over 6 (152) to 8 (203), incl.	0.020 (0.51)	0.060 (1.52)
Over 8 (203) to 12 (305), incl.	0.030 (0.76)	0.060 (1.52)

¹Tolerance applies to inside or outside diameter.

COPPER BERYLLIUM (CONT)

WEIGHT (LBS PER FT)

ASTM B194

ALLOY C17200

ASTM B196

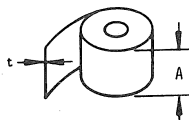

COPPER BERYLLIUM IN ROLLS
HEAT-TREATABLE ①
SOFT

THICKNESS "t"		WIDTH "A" INCHES	*POUNDS LINEAL FOOT
IN INCHES	FRACTION OR B & S GAUGE		
.0031	40	6 - 8	.074
.0040	38	6 - 8	.098
.0050	36	6 - 8	.126
.0063	34	6 - 8	.154
.0071	33	6 - 8	.175
.0080	32	6 - 8	.203
.0089	31	6 - 8	.217
.0100	30	6 - 8	.252
.0113	29	6 - 8	.280
.0126	28	6 - 8	.315
.0142	27	6 - 8	.357
.0150	-	6 - 8	.364
.0159	26	6 - 8	.399
.0172	-	6 - 8	.448
.0180	25	6 - 8	.481
.0201	24	6 - 8	.504
.0226	23	6 - 8	.588
.0253	22	6 - 8	.630
.0320	20	6 - 8	.798
.0403	18	6 - 8	1.00
.0453	17	6 - 8	1.13



ROUND COPPER BERYLLIUM ROD

DIMENSION "A" INCHES	POUNDS PER FOOT	POUNDS 12' LENGTH
3/32	.025	.300
1/8	.044	.528
5/32	.068	.816
3/16	.098	1.18
7/32	.135	1.62
1/4	.175	2.10
9/32	.221	2.65
5/16	.273	3.28
11/32	.333	4.00
3/8	.394	4.73
7/16	.536	6.43
1/2	.700	8.40
5/8	1.09	13.1
11/16	1.33	16.0
3/4	1.57	18.8
7/8	2.14	25.7
15/16	2.46	29.5
1	2.80	33.6

DIMENSION "A" INCHES	POUNDS PER FOOT	POUNDS 12' LENGTH
1-1/8	3.54	42.5
1-1/4	4.37	52.4
1-3/8	5.26	63.1
1-1/2	6.30	75.6
1-3/4	8.57	103.
1-7/8	9.84	118.
2	11.2	134.
2-1/8	12.6	151.
2-1/4	14.1	169.
*2-1/2	17.5	210.
**2-5/8	19.3	232.
**2-3/4	21.2	254.
**3	25.2	302.
**3-1/8	27.3	328.
**3-3/8	31.9	383.
**3-1/2	34.3	412.
**4	44.8	538.

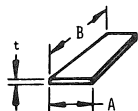

COPPER BERYLLIUM SHEET
HEAT-TREATABLE

TEMPER	THICKNESS "t" INCHES	WIDTH "A" INCHES	LENGTH "B" INCHES	*POUNDS PER SHEET
Soft	.051	6 - 8	96	10.4
Soft	.064	6 - 8	96	13.2
H-H	.064	6 - 8	96	13.2

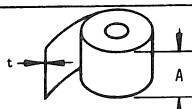

COPPER BERYLLIUM IN ROLLS
HEAT-TREATABLE ①
HALF-HARD

THICKNESS "t"		WIDTH "A" INCHES	*POUNDS LINEAL FOOT
IN INCHES	FRACTION OR B & S GAUGE		
.0031	40	6 - 8	.074
.0040	38	6 - 8	.098
.0050	36	6 - 8	.126
.0056	35	6 - 8	.140
.0060	-	6 - 8	.148
.0063	34	6 - 8	.154
.0071	33	6 - 8	.175
.0080	32	6 - 8	.203
.0089	31	6 - 8	.217
.0100	30	6 - 8	.252
.0113	29	6 - 8	.280
.0120	-	6 - 8	.289
.0126	28	6 - 8	.315
.0142	27	6 - 8	.357
.0150	-	6 - 8	.364
.0160	26	6 - 8	.399
.0172	-	6 - 8	.448
.0180	25	6 - 8	.481
.0201	24	6 - 8	.504
.0226	23	6 - 8	.588
.0253	22	6 - 8	.630
.0320	20	6 - 8	.798
.0403	18	6 - 8	1.00
.0453	17	6 - 8	1.13

PHOSPHOR BRONZE

SECTION 10

TABLE OF CONTENTS

	PAGE (S)
WIRE	10-2
FOIL	10-2
STRIP	10-2
ASTM B103 SPECIFICATION	10-5
ASTM B139 SPECIFICATION	10-6
ASTM B159 SPECIFICATION	10-6
ASTM B248 (TOLERANCES)	12-10 & 12-11
ASTM B249 (TOLERANCES)	12-12 & 12-13
ASTM B250 (TOLERANCES)	12-14
NOTES	10-4
CROSS REFERENCE INDEX	10-3
WEIGHT (LBS PER FT)	10-7

TEK STANDARDS PERTAINING TO MATERIALS

062-1702-00	Welding, Soldering & Brazing	D-100	Die Casting & Molding Standards
062-1703-00	Finishes, Glossary of Terms		
062-1713-00	Drafting, Aluminum Extrusions	H Series	Tooling Standards
062-1718-00	Finish Quality, Cosmetic		
062-2845-00	Mechanically Applied Finishes		
062-2848-00	Bend Allowance & Deduction		
062-2850-00	Finish, Surface Texture	062-5818-01	Aluminum (M-150)
062-2854-00	Finishes, Chemical & Electromechanical	M-200	Brass
062-2856-00	Non-Additive Finishes for Brass, Copper & Copper Alloys	M-250	Copper
062-2860-00	Finishes, Anodized	M-300	Copper-Beryllium
062-2863-00	Zinc Die Cast Finishes, Chromate Conversion Coatings	M-350	Beryllium-Nickel
062-2868-00	Finish, Etch Chromate & Lacquer (On Aluminum)	M-400	Phosphor-Bronze
062-2868-01	Chromate Conversion Coating for Al Die Casting Alloy 3431	M-450	Steel
062-2871-00	Finish, Passivating	M-500	Stainless Steel
062-5818-00	General Information about Bulk Raw Materials	M-550	Magnetic Shielding Materials (Iron-Nickel & Nickel-Silver)
		M-600	Copper-Nickel-Zinc

COST CODE

(CC COLUMN)

CODE	A	B	C	D	E	F	G	H	I	J	K	L	M	N	O
≈ VALUE with +	.75¢	2¢	3.75¢	6¢	10¢	18¢	35¢	60¢	\$1	\$2	\$3.75	\$6	\$10	\$18	\$35+
≈ VALUE no suffix	.5¢	1.5¢	3¢	5¢	8¢	15¢	25¢	50¢	75¢	\$1.50	\$3	\$5	\$8	\$15	\$25
≈ VALUE with -	.2¢	1.25¢	2.5¢	4.25¢	7¢	13¢	22¢	40¢	65¢	\$1.25	\$2.50	\$4.25	\$7	\$13	\$22

NOTE: Costs may vary from order to order due to order quantities, vendor, etc.

PHOSPHOR-BRONZE (CONT)

WIRE

SIZE	ALLOY	TEMPER	SPECIFICATION* (ASTM)	TOLERANCE** (ASTM)	PART NUMBER	CC	OTHER
.005 x 1.125	C51000	Spring	B159	B250	251-0366-00	oz I	.002 silver one side
.006 ± .0004 x .048 ± .0015	C51000	Spring	B103	B248	258-0424-00	oz H+	
.0063 x .094 ± .001	C51000	Spring	B103	B248	251-0335-01	oz H-	
.010 x .250	C51000	Spring	B103	B248	251-0448-01	1b L-	
.010 + .001 x .400 ± .005	C51000	Spring	B103	B248	251-0448-05	1b J+	
.010 x .875 ± .010	C51000	Spring	B103	B248	251-0448-04	1b K	
.010 x 1.000	C51000	Spring	B103	B248	251-0448-03	1b J+	
.013 x 1.000	C51000	Spring	B103	B248	251-0340-02	1b L	
.0159 x .625	C51000	Spring	B103	B248	251-0464-00	1b M-	
.017 x .375	C52100	One half hard	B103	B248	251-0362-01	oz J+	
.0201 dia	C51000	Spring	B159	B250	251-0383-00	T0 L+	.0001 14K gold clad
.025 x .4375 ± .005	C52100	One half hard	B103	B248	258-0405-00	1b J+	
.025 x .750 ± .005	C51000	Spring	B103	B248	251-0341-01	1b K+	
.025 x .750 ± .005	C52100	One half hard	B103	B248	258-0405-02	1b K	
.040 x .850	C51000	Spring	B103	B248	258-0452-00	1b K-	
.062 dia	C51000	Spring	B103	B248	251-0325-00	1b J-	
.125 dia	C51000	Spring	B139	B249	258-0402-00	1b K	
.250 dia	C51000	Spring	B103	B248	258-0470-00	1b K	

FOIL

SIZE	ALLOY	TEMPER	SPECIFICATION* (ASTM)	TOLERANCE** (ASTM)	PART NUMBER	CC	OTHER
.003 x .219	C52100	One half hard	B103	B248	251-0385-00	oz K+	+.001 silver plated, 1 side
.003 x 4.000	C51000	Spring	B103	B248	251-0472-00	oz G-	
.005 x .500	C52100	One half hard	B103	B248	251-0367-00	oz N	+.002 silver plated, 1 side

STRIP

SIZE	ALLOY	TEMPER	SPECIFICATION* (ASTM)	TOLERANCE** (ASTM)	PART NUMBER	CC	OTHER
.006 x 4.000	C51000	Spring	B103	B248	258-0453-00		Two gold inlays
.0063 x 1.510 2.000 - .016	C51000	Spring	B103	B248	251-0335-04	1b K	
.0063 x 6.000	C51000	Spring	B103	B248	251-0335-00	oz F+	
.010 x 1.875 ± .008	C51000	Spring	B103	B248	251-0448-02	1b K+	
.010 x 3.490 + .000 - .016	C51000	Spring	B103	B248	251-0448-07	1b K-	
.010 + .001 x 5.375 ± .005 x 72 lg	C51000	Spring	B103	B248	251-0448-06	1b J+	
.010 ± .0015 x 12.000	C51000	Spring	B103	B248	251-0448-00	1b K	
.013 x 12.000	C51000	Spring	B103	B248	251-0340-01	1b L-	
.0159 x 6.000	C51000	Spring	B103	B248	251-0464-04		
.017 x 1.375	C52100	One half hard	B103	B248	251-0362-00	oz K-	+.0025 silver plated, 1 side
.025 x 12.000	C51000	Spring	B103	B248	251-0341-00	1b K	
.032 x 12.000	C51000	Spring	B103	B248	258-0504-00	1b K	

* MECHANICAL PROPERTIES CAN BE FOUND ON PAGES 10-5 & 10-6.
 ** FOR TOLERANCES SEE PAGES 12-12 THRU 12-23.

CROSS REFERENCE INDEX

PHOSPHOR BRONZE

PART NUMBER	DESCRIPTION	SIZE	PAGE NO.	STATUS [§]
251-0325-00	Wire	.062 dia	10-2	OB
251-0335-00	Strip	.0063 x 6.000	10-2	CR
251-0335-01	Wire	.0063 x .094	10-2	CR
251-0335-04	Strip	.0063 x 2.000	10-2	CS
251-0340-00	Wire	.013 x .750		OT
251-0340-01	Strip	.013 x 12.000	10-2	CR
251-0340-02	Wire	.013 x 1.000	10-2	CR
251-0341-00	Strip	.025 x 12.000	10-2	CR
251-0341-01	Wire	.025 x .750	10-2	CR
251-0362-00	Strip	.017 x 1.375	10-2	CS
251-0362-01	Wire	.017 x .375	10-2	OB
251-0366-00	Wire	.005 x 1.125	10-2	CS
251-0367-00	Foil	.005 x .500	10-2	CR
251-0374-00	Wire	.025 dia		DL
251-0383-00	Wire	.0201 dia	10-2	CR
251-0385-00	Foil	.003 x .219	10-2	CS
251-0397-00	Wire	.0064 x .125		DL
251-0411-00	Wire	.010 x .125		DL
251-0448-00	Strip	.010 x 12.000	10-2	CR
251-0448-01	Wire	.010 x .250	10-2	CS
251-0448-02	Strip	.010 x 1.875	10-2	CR
251-0448-03	Wire	.010 x 1.000	10-2	CS
251-0448-04	Wire	.010 x .875	10-2	CR
251-0448-05	Wire	.010 x .400	10-2	CR
251-0448-06	Strip	.010 x 5.375	10-2	OB
251-0448-07	Strip	.010 x 3.490	10-2	CR
251-0464-00	Wire	.0159 x .625	10-2	CS
251-0464-01	Strip	.0159 x 2.875		NP
251-0464-03	Wire	.0159 x 1.000		DL
251-0464-04	Strip	.0159 x 6.000	10-2	CR
251-0464-05	Wire	.0159 x .250		DL
251-0472-00	Foil	.003 x 4.000	10-2	CR
258-0347-00	Wire	.006 x .125		DL
258-0390-00	Strip	.006 x 2.000		OB
258-0402-00	Wire	.125 dia	10-2	CR
258-0405-00	Wire	.025 x .4375	10-2	CR
258-0405-02	Wire	.025 x .750	10-2	CR
258-0415-00	Wire	.0179 dia		DL
258-0424-00	Wire	.006 x .048	10-2	CR
258-0452-00	Wire	.040 x .850	10-2	CR
258-0453-00	Strip	.006 x 4.000	10-2	CR
258-0462-00	Foil	.004 x .550		DL
258-0470-00	Wire	.250 dia	10-2	CR
258-0504-00	Strip	.032 x 12.000	10-2	CR

§§ STATUS CODES

CR	Current Production
EN	Engineering
PP	Pre-Production
CS	Customer Service
NP	Non-Production
DL	Deleted
OB	Obsolete Instrument
CM	Custom Mod Instrument
DS	Digital Systems
OT	Obsolescent Instrument
MP	Modified Part
LR	Last Supply Current
LS	Last Supply Customer Service
VN	Vendor
TC	Tequipment Current Production
IN	International
SC	Sony/Tek Current Production

THE STATUS IN THIS CATALOG WAS CORRECT AT THE TIME IT WAS PUBLISHED, BUT IT IS SUBJECT TO CHANGE.

§ TO USE A PART WITH THIS STATUS ON A NEW INSTRUMENT REQUIRES THAT A NEW PURCHASED PART INITIATION FORM (PPIF) BE INITIATED.

(A GLOSSARY OF TERMS FOR THESE STATUS CODES CAN BE FOUND ON PAGE 0-10).

COST CODE

(CC COLUMN)

CODE	≈ VALUE with -	≈ VALUE no suffix	≈ VALUE with +
A	.2¢	.5¢	.75¢
B	1.25¢	1.5¢	2¢
C	2.5¢	3¢	3.75¢
D	4.25¢	5¢	6¢
E	7¢	8¢	10¢
F	13¢	15¢	18¢
G	22¢	25¢	35¢
H	40¢	50¢	60¢
I	65¢	75¢	\$1
J	\$1.25	\$1.50	\$2
K	\$2.50	\$3	\$3.75
L	\$4.25	\$5	\$6
M	\$7	\$8	\$10
N	\$13	\$15	\$18
O	\$22	\$25	\$35+

NOTE: Costs may vary from order to order due to order quantities, vendor, etc.

NOTES

10

COST CODE

(CC COLUMN)

CODE	≈ VALUE with -	≈ VALUE no suffix	≈ VALUE with +
A	.2¢	.5¢	.75¢
B	1.25¢	1.5¢	2¢
C	2.5¢	3¢	3.75¢
D	4.25¢	5¢	6¢
E	7¢	8¢	10¢
F	13¢	15¢	18¢
G	22¢	25¢	35¢
H	40¢	50¢	60¢
I	65¢	75¢	\$1
J	\$1.25	\$1.50	\$2
K	\$2.50	\$3	\$3.75
L	\$4.25	\$5	\$6
M	\$7	\$8	\$10
N	\$13	\$15	\$18
O	\$22	\$25	\$35+

NOTE: Costs may vary from order to order
due to order quantities, vendor, etc.

PHOSPHOR-BRONZE (CONT)

ASTM B103

TENSILE STRENGTH REQUIREMENTS AND APPROXIMATE ROCKWELL HARDNESS VALUES FOR COPPER ALLOY NUMBER C51000.

TENSILE STRENGTH REQUIREMENTS AND APPROXIMATE ROCKWELL HARDNESS VALUES FOR ALLOY NUMBER C52100.

TEMPER		THICKNESS, IN	TENSILE STRENGTH *KSI (MIN)		YIELD STRENGTH		ROCKWELL HARDNESS			
STD. DESIG.	FORMER DESIG.		MIN	MAX	MIN	MAX	B SCALE		30T SCALE	
							MIN	MAX	MIN	MAX
060	SOFT	OVER .039	43	58			16	64	-	-
		OVER .029	43	58			-	-	32	59
		OVER .02-.039	43	58			12	60	-	-
		OVER .01-.029	43	58			-	-	24	53
		.003 TO .01	43	58						
H02	HALF-HARD	OVER .039	58	73	47	68	64	85	-	-
		OVER .029	58	73	47	68	-	-	59	73
		OVER .02-.039	58	73	47	68	60	82	-	-
		OVER .01-.029	58	73	47	68	-	-	58	69
		.003 TO .01	58	73						
H04	HARD	OVER .039	76	91	74	88	86	93	-	-
		OVER .029	76	91	74	88	-	-	73	78
		OVER .02-.039	76	91	74	88	84	91	-	-
		OVER .01-.029	76	91	74	88	-	-	71	75
		.003 TO .01	76	91						
H06	EXTRA HARD	OVER .039	88	103	85	102	92	96	-	-
		OVER .029	88	103	85	102	-	-	71	81
		OVER .02-.039	88	103	85	102	89	95	-	-
		OVER .01-.029	88	103	85	102	-	-	74	78
		.003 TO .01	88	103						
H08	SPRING	OVER .039	95	110	92	108	94	98	-	-
		OVER .029	95	110	92	108	-	-	79	82
		OVER .02-.039	95	110	92	108	92	97	-	-
		OVER .01-.029	95	110	92	108	-	-	76	80
		.003 TO .01	95	110						

TEMPER		THICKNESS, IN	TENSILE STRENGTH *KSI (MIN)		YIELD STRENGTH		ROCKWELL HARDNESS			
STD. DESIG.	FORMER DESIG.		MIN	MAX	MIN	MAX	B SCALE		30T SCALE	
							MIN	MAX	MIN	MAX
060	SOFT	OVER .039	53	67			29	70	-	-
		OVER .029	53	67			-	-	38	68
		OVER .02-.039	53	67			20	66	-	-
		OVER .01-.029	53	67			-	-	27	62
H02	HALF-HARD	OVER .039	69	84	51	75	76	91	-	-
		OVER .029	69	84	51	75	-	-	67	78
		OVER .02-.039	69	84	51	75	69	88	-	-
		OVER .01-.029	69	84	51	75	-	-	63	75
H04	HARD	OVER .039	85	100	78	95	91	97	-	-
		OVER .029	85	100	78	95	-	-	76	81
		OVER .02-.039	85	100	78	95	89	95	-	-
		OVER .01-.029	85	100	78	95	-	-	73	80
H06	EXTRA HARD	OVER .039	97	112	92	107	95	100	-	-
		OVER .029	97	112	92	107	-	-	78	83
		OVER .02-.039	97	112	92	107	93	98	-	-
		OVER .01-.029	97	112	92	107	-	-	77	82
H08	SPRING	OVER .039	105	119	100	113	97	102	-	-
		OVER .029	105	119	100	113	-	-	79	84
		OVER .02-.039	105	119	100	113	95	100	-	-
H10	EXTRA SPRING	OVER .01-.029	105	119	100	113	-	-	78	83
		OVER .039	110	122	116	195	98	103	-	-
		OVER .029	110	122	116	195	-	-	80	84
		OVER .02-.039	110	122	116	195	96	101	-	-
		OVER .01-.029	110	122	116	195	-	-	79	83

10

The dimensions and tolerances for material covered by this Specification (B103) can be found in Specification ASTM B248.†† (see pages 12-12 & 12-15)

†† The full text of this ASTM is available for review at 78-567, or, for more information, call Norma, Ext. 2577, or Comp. Eval., Bella Geotina, Ext. 2315.

* KSI = 1000 psi

PHOSPHOR-BRONZE (CONT)

TENSILE REQUIREMENTS, ALLOY NUMBER C51000.

ASTM B139

TEMPER DESIGNATION		DIAMETER DISTANCE BETWEEN PARALLEL SURFACES IN INCHES	MINIMUM TENSILE STRENGTH *KSI	ELONGATION IN 4X DIAMETER OR THICKNESS, MINIMUM %
STANDARD	FORMER			
060	SOFT	ROUNDS UNDER .25	40 TO 58	---
H04	HARD	ROUNDS UNDER .25	80 TO 128	---
		ROUNDS & HEXAGONS .25 TO .5	70 MINIMUM	13
		OVER .5 TO 1	60 MINIMUM	15
		OVER 1	55 MINIMUM	18
		SQUARE & RECTANGLE .25 TO .375	60 MINIMUM	10
		OVER .375	55 MINIMUM	15
H08	SPRING	ROUNDS UNDER .026	125 MINIMUM	---
		.026 TO .0625	115 MINIMUM	---
		OVER .0625 TO .125	110 MINIMUM	---
		OVER .125 TO .25	105 MINIMUM	3.5
		OVER .25 TO .375	100 MINIMUM	5.
		OVER .375 TO .5	90 MINIMUM	9.

TENSILE REQUIREMENTS FOR SPRING TEMPER ALLOY C51000
ROUND OR SQUARE MATERIAL

ASTM B159 (CONT)

DIAMETER OR DISTANCE BETWEEN PARALLEL SURFACES IN INCHES	MINIMUM TENSILE STRENGTH, *KSI	ELONGATION IN 2 IN. MIN %
.025 AND UNDER	145	---
OVER .025 TO .062	135	---
OVER .062 TO .125	130	---
OVER .125 TO .25	125	---
OVER .25 TO .375	120	5
OVER .375 TO .5	105	9

TENSILE STRENGTH REQUIREMENTS FOR FLAT MATERIAL
ALLOY NUMBER C51000.

TEMPER DESIGNATION		TENSILE STRENGTH, *KSI
STANDARD	FORMER	
061	SOFT	43 TO 58
H02	HALF-HARD	58 TO 73
H04	HARD	76 TO 91
H06	EXTRA-HARD	88 TO 103
H08	SPRING	95 TO 110
H10	EXTRA-SPRING	100 TO 114

10

TENSILE REQUIREMENTS FOR ROUND OR SQUARE MATERIAL
FOR GENERAL PURPOSES. ALLOY NUMBER C51000.

ASTM B159

TEMPER DESIGNATION		TENSILE STRENGTH, *KSI
STANDARD	FORMER	
061	SOFT	43 TO 58
H01	QUARTER-HARD	60 TO 76
H02	HALF-HARD	80 TO 97
H03	THREE-QTR-HARD	96 TO 115
H04	HARD	108 TO 128

The dimensions and tolerances for material covered by these Specifications (B139 & B159) can be found in Specifications ASTM B249 and ASTM B250.++ (see pages 12-16 thru 12-21)

++ The full text of this ASTM is available for review at 78-567, or for more information, call Norma, Ext 2577, or Comp. Eval., Bella Geotina, Ext. 2315.

*KSI = 1000 psi

PHOSPHOR-BRONZE (CONT)

WEIGHT (LBS PER FT)

ASTM B103 : ALLOY C51000

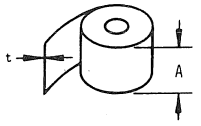

SPRING PHOSPHOR BRONZE
IN ROLLS

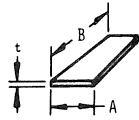

SPRING PHOSPHOR BRONZE SHEET

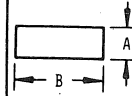

SPRING PHOSPHOR BRONZE STRIP

THICKNESS "t"		WIDTH "A" INCHES	POUNDS LINEAL FOOT
IN INCHES	FRACTION OR B & S GAUGE		
.0031	40 ga.	8	.095
.005	36 ga.	8	.154
.005	36 ga.	12	.230
.0063	34 ga.	8	.194
.008	32 ga.	8	.246
.008	32 ga.	12	.369
.010	30 ga.	8	.307
.010	30 ga.	12	.461
.0126	28 ga.	8	.387
.0126	28 ga.	12	.581
.0159	26 ga.	8	.488
.0159	26 ga.	12	.733
.0179	25 ga.	8	.550
.0179	25 ga.	12	.825
.0201	24 ga.	8	.617
.0201	24 ga.	12	.926
.0253	22 ga.	8	.777
.0253	22 ga.	12	1.17
.032	20 ga.	8	.983
.032	20 ga.	12	1.47
.0359	19 ga.	8	1.10
.0359	19 ga.	12	1.65
.0403	18 ga.	8	1.24
.0403	18 ga.	12	1.86
.0453	17 ga.	8	1.40
.0453	17 ga.	12	2.09
.0508	16 ga.	8	1.56
.0508	16 ga.	12	2.34
.0641	14 ga.	8	1.97
.0641	14 ga.	12	2.95

THICKNESS "t"		WIDTH "A" INCHES	LENGTH "B" INCHES	POUNDS LINEAL FOOT	POUNDS PER SHEET
IN INCHES	FRACTION OR B & S GAUGE				
.020	24 ga.	8	96	.617	4.94
.020	24 ga.	12	96	.926	7.41
.0253	22 ga.	8	96	.777	6.22
.0253	22 ga.	12	96	1.17	9.36
.032	20 ga.	8	96	.983	7.86
.032	20 ga.	12	96	1.47	11.8
.0403	18 ga.	8	96	1.24	9.92
.0403	18 ga.	12	96	1.86	14.9
.0453	17 ga.	8	96	1.40	11.2
.0453	17 ga.	12	96	2.09	16.7
.0508	16 ga.	8	96	1.56	12.5
.0508	16 ga.	12	96	2.34	18.7
.0641	14 ga.	8	96	1.97	15.8
.0641	14 ga.	12	96	2.95	23.6
.072	13 ga.	8	96	2.21	17.7
.0808	12 ga.	8	96	2.48	19.8
.0907	11 ga.	8	96	2.79	22.3
.0907	11 ga.	12	96	4.40	35.0
.125	1/8	12	96	5.90	47.2
.1285	8 ga.	8	96	3.95	31.6
.1875	3/16	8	96	5.76	46.1
.250	1/4	8	96	7.68	61.4

DIMENSION "A" INCHES	DIMENSION "B" INCHES	POUNDS PER FOOT	POUNDS 12' LENGTHS
1/16	x 3/8	.090	1.08
	1/2	.120	1.44
	5/8	.150	1.80
	3/4	.180	2.16
3/32	x 1	.240	2.88
	x 3/8	.135	1.62
	1/2	.180	2.16
	5/8	.225	2.70
1/8	x 3/4	.270	3.24
	x 1	.360	4.32
	x 1/2	.240	2.88
	7/8	.420	5.04
		.480	5.76

MATERIAL NAMES:

The standard used at Tek for naming parts is H6 (Cataloging Handbook). In some cases, the ASTM uses different names than H6. In such cases the H6 name will be used.

NAME	SHAPE
BAR	<p>(also Hex, Dodecagon, etc)</p> <p>$\geq .375$ (≥ 9.525 mm)</p> <p>$\geq .375$ (≥ 9.525 mm)</p> <p>$\geq .375$ (≥ 9.525 mm)</p> <p>$\geq .375$ (≥ 9.525 mm)</p> <p>$\geq .375$ (≥ 9.525 mm)</p> <p>$\geq .375$ (≥ 9.525 mm)</p> <p>$\geq .375$ to 12" (≥ 9.525 to 304.8 mm)</p> <p>$\geq .094$ (≥ 2.381 mm)</p>
ROD	DO NOT USE FOR METALS (Deleted from H6)
STRIP	<p>1.25 to 12" (31.75 mm to 304.8 mm)</p> <p>$> .005$ ($> .132$ mm) $< .094$ (< 2.381 mm)</p>
*WIRE & *ROD	<p>(also Hex, Dodecagon, etc)</p> <p>$< .375$ (≥ 9.525 mm)</p> <p>$< .375$ (≥ 9.525 mm)</p> <p>$< .375$ (≥ 9.525 mm)</p> <p>$< .375$ (≥ 9.525 mm)</p> <p>$< .375$ (≥ 9.525 mm)</p> <p>$< .375$ (≥ 9.525 mm)</p> <p>< 1.250 (< 31.75 mm)</p> <p>$> .005$ $< .094$ ($> .132$ mm) (< 2.381 mm)</p> <p>*Use WIRE for metal, and ROD for nonmetallic parts.</p>
SHEET	<p>$> 12"$ across narrowest flats. (> 304.8 mm)</p> <p>$> .005$ ($> .132$ mm)</p>
FOIL & **FILM	<p>any width</p> <p>$\leq .005$ ($\leq .132$ mm)</p> <p>Use FOIL for metal, and FILM for nonmetallic parts.</p>

Some materials do not yet have specifications and may change without notice until the spec is finished. Also, some are exclusively used by one department and may be changed without notice by them.

COPPER

SECTION 11

TABLE OF CONTENTS

	PAGE (S)
WIRE	11-2
BAR	11-2
FOIL	11-2
STRIP	11-2
SHEET	11-2
TUBE	11-2
ASTM B152 (SPECIFICATION)	11-5
ASTM B301 (SPECIFICATION)	11-5
ASTM B111 (SPECIFICATION & TOLERANCES) ...	11-6
ASTM B248 (TOLERANCES)	12-10 & 12-11
ASTM B249 (TOLERANCES)	12-12 & 12-13
NOTES	11-4
CROSS REFERENCE INDEX	11-3
WEIGHT (LBS PER FT)	11-7 & 11-8

TEK STANDARDS PERTAINING TO MATERIALS

062-1702-00	Welding, Soldering & Brazing	D-100	Die Casting & Molding Standards
062-1703-00	Finishes, Glossary of Terms		
062-1713-00	Drafting, Aluminum Extrusions	H Series	Tooling Standards
062-1718-00	Finish Quality, Cosmetic		
062-2845-00	Mechanically Applied Finishes		
062-2848-00	Bend Allowance & Deduction		
062-2850-00	Finish, Surface Texture	062-5818-01	Aluminum (M-150)
062-2854-00	Finishes, Chemical & Electromechanical	M-200	Brass
062-2856-00	Non-Additive Finishes for Brass, Copper & Copper Alloys	M-250	Copper
062-2860-00	Finishes, Anodized	M-300	Copper-Beryllium
062-2863-00	Zinc Die Cast Finishes, Chromate Conversion Coatings	M-350	Beryllium-Nickel
062-2868-00	Finish, Etch Chromate & Lacquer (On Aluminum)	M-400	Phosphor-Bronze
062-2868-01	Chromate Conversion Coating for Al Die Casting Alloy 3431	M-450	Steel
062-2871-00	Finish, Passivating	M-500	Stainless Steel
062-5818-00	General Information about Bulk Raw Materials	M-550	Magnetic Shielding Materials (Iron-Nickel & Nickel-Silver)
		M-600	Copper-Nickel-Zinc

11

COST CODE

(CC COLUMN)

CODE	A	B	C	D	E	F	G	H	I	J	K	L	M	N	O
≈ VALUE with +	.75¢	2¢	3.75¢	6¢	10¢	18¢	35¢	60¢	\$1	\$2	\$3.75	\$6	\$10	\$18	\$35+
≈ VALUE no suffix	.5¢	1.5¢	3¢	5¢	8¢	15¢	25¢	50¢	75¢	\$1.50	\$3	\$5	\$8	\$15	\$25
≈ VALUE with -	.2¢	1.25¢	2.5¢	4.25¢	7¢	13¢	22¢	40¢	65¢	\$1.25	\$2.50	\$4.25	\$7	\$13	\$22

NOTE: Costs may vary from order to order, due to order quantities, vendor, etc.

COPPER (CONT)

WIRE

SIZE	ALLOY	TEMPER	SPECIFICATION* (ASTM)	TOLERANCE** (ASTM)	PART NUMBER	CC	OTHER
.006 dia		Hard			258-0513-00	ft B	.0001 to .0002 14K gold pl.
.0108 x .750	C11000		B152	B248	251-3015-00	1b K	
.019 ± .001 x .500 x 12 ft. long	C11000	Soft annealed	B152	B248	251-0420-00	1b J	
.0203 dia x 12 ft. long	C41300	One qtr hard	B591	B248	258-0340-00	T0 O	
.0216 x 1.000	C11000	Soft annealed	B152	B248	251-0338-03	1b K-	
.0216 x 1.125	C11000	Soft	B152	B248	258-0518-00	ft F+	
.0938 dia x 12 ft. long	C18700	Hard	B301	B249	251-0488-00	1b J+	
.188 dia ± .002	C11000	Hard	B1		258-0533-00	1b L-	
.312 dia ± .005 x 12 ft. long	C14500 or C11000	One half hard	B301	B249	258-0438-00	1b J-	

BAR

SIZE	ALLOY	TEMPER	SPECIFICATION* (ASTM)	TOLERANCE** (ASTM)	PART NUMBER	CC	OTHER
.125 x .750 x 12 ft. long	C11000	One half hard	B152	B248	251-0418-00	1b K	
.125 x 1.500 x 12 ft. long	C11000	One half hard	B152	B248	251-0417-00	1b K	
.125 x 2.000 x 12 ft. long	C11000	One half hard	B152	B248	258-0491-00	1b K-	
.1875 x .750 x 12 ft. long	C11000	Hard	B152	B248	251-0361-00	1b I	
.250 x 1.500 x 12 ft. long	C11000	Hard	B152	B248	251-0370-00	1b I+	
.500 ± .0025	C14500 or C18700	One half hard	B301	B249	258-0439-00	1b J+	

FOIL

SIZE	ALLOY	TEMPER	SPECIFICATION* (ASTM)	TOLERANCE** (ASTM)	PART NUMBER	CC	OTHER
.0015 x .293 ± .002 x 1500 ft-MIN	C11000	Drawn	B152	B248	258-0434-00	1b L	Tin plated
.002 x .346 ± .002	C11000	Drawn	B152	B248	258-0435-00	1b K	
.002 x .383 ± .002	C11000	Drawn	B152	B248	251-0466-02	1b L-	
.002 x .473 ± .002 x 2500 ft-MIN	C11000	Drawn	B152	B248	258-0391-00	1b L	
.002 x .500	C11000	Drawn	B152	B248	251-0466-00	1b K+	
.0042 x 5.500	C11000	One qtr hard	B152	B248	251-0330-04	1b K+	
.002 x .680 x 1500 ft 1g-MIN	C11000	Drawn	B152	B248	258-0425-00	1b K	
.002 x 1.000 ± .005	C11000	Drawn	B152	B248	258-0493-00	1b K	
.004 x .080					176-0176-00	ft B	
.0042 x 30.000	C11000	One qtr hard	B152	B248	251-0330-00	1b L-	
.005 x 12.000	C11000	Soft annealed	B152	B248	251-0365-00	1b K	

STRIP

SIZE	ALLOY	TEMPER	SPECIFICATION* (ASTM)	TOLERANCE** (ASTM)	PART NUMBER	CC	OTHER
.0108 x .500	C11000	Soft annealed	B152	B248	251-0353-01	1b K	
.0108 x .875	C11000	Soft annealed	B152	B248	251-0353-02	1b K	
.0108 x 1.250	C11000	Soft annealed	B152	B248	258-0488-00	1b E	
.0108 x 1.750	C11000	Soft annealed	B152	B248	251-0353-03	1b J+	
.0108 x 12.000	C11000	Soft annealed	B152	B248	251-0353-00	1b K	
.0216 x .875	C11000	Soft annealed	B152	B248	251-0338-01	1b J+	
.0216 x 1.250	C11000	Soft annealed	B152	B248	176-0170-00	1b K	
.0216 x 2.750	C11000	Soft annealed	B152	B248	251-0338-02	1b J+	
.0216 x 12.000	C11000	Soft annealed	B152	B248	251-0338-00	1b K	
.032 x 12.000 x 8 ft. long	C11000	Lt. cold rolled	B152	B248	258-0329-00	1b J+	

SHEET

SIZE	ALLOY	TEMPER	SPECIFICATION* (ASTM)	TOLERANCE** (ASTM)	PART NUMBER	CC	OTHER
.065 x 36.000 x 96 inches	C11000	Hard	B152	B248	258-0448-00	1b K-	
.065 x 36.000 x 96 inches	C11000	Soft annealed	B152	B248	251-0416-00	1b K-	
.00675 x 30.000	C11000	Soft annealed	B152	B248	258-0490-00	1b L-	

TUBE

SIZE	ALLOY	TEMPER	SPECIFICATION* (ASTM)	TOLERANCE** (ASTM)	PART NUMBER	CC	OTHER
.205 ± .001 ID x .015 ± .0015 wall x 49 long ± .0625	C12200	Light drawn	B111	B111	258-0386-00	1b L-	

* FOR MECHANICAL PROPERTIES, SEE PAGE 11-5 & 11-6.
 ** FOR TOLERANCES, SEE PAGES 12-12 THRU 12-23.

CROSS REFERENCE INDEX

COPPER

PART NUMBER	DESCRIPTION	SIZE	PAGE NO.	STATUS ^{§§}
176-0170-00	Strip	.0216 x 1.250	11-2	CS
176-0176-00	Foil	.004 x .080	11-2	CR
251-0330-00	Foil	.0042 x 30.000	11-2	CR
251-0330-04	Foil	.0042 x 5.500	11-2	CR
251-0338-00	Strip	.0216 x 12.000	11-2	CR
251-0338-01	Strip	.0216 x .875	11-2	CS
251-0338-02	Strip	.0216 x 2.750	11-2	CR
251-0338-03	Wire	.0216 x 1.000	11-2	PP
251-0338-04	Strip	.0216 x 1.750	11-2	DL
251-0353-00	Strip	.0108 x 12.000	11-2	CR
251-0353-01	Strip	.0108 x .500	11-2	CR
251-0353-02	Strip	.0108 x .875	11-2	CR
251-0353-03	Strip	.0108 x 1.750	11-2	CR
251-0361-00	Bar	.1875 x .750	11-2	CS
251-0365-00	Foil	.005 x 12.000	11-2	CR
251-0365-01	Foil	.005 x 1.281		DL
251-0370-00	Bar	.250 x 1.500	11-2	CS
251-0416-00	Sheet	.065 x 36.000	11-2	CR
251-0417-00	Bar	.125 x 1.500	11-2	OB
251-0418-00	Bar	.125 x .750	11-2	OB
251-0420-00	Wire	.019 x .500	11-2	OB
251-0436-00	Foil	.005 x .500		OB
251-0466-00	Foil	.002 x .500	11-2	CR
251-0466-01	Foil	.002 x .865		OB
251-0466-02	Foil	.002 x .383	11-2	CR
251-0488-00	Wire	.0938 dia	11-2	CR
251-3015-00	Wire	.0108 x .750	11-2	CR
258-0329-00	Strip	.032 x 12.000	11-2	CR
258-0340-00	Wire	.0203 dia	11-2	CR
258-0386-00	Tube	.205 x .015 wall	11-2	CR
258-0391-00	Foil	.002 x .473	11-2	CR
258-0425-00	Foil	.002 x .680	11-2	CR
258-0434-00	Foil	.0015 x .293	11-2	CR
258-0435-00	Foil	.002 x .346	11-2	CR
258-0438-00	Wire	.312 dia	11-2	CR
258-0439-00	Bar	.500 dia	11-2	CR
258-0448-00	Sheet	.065 x 36.000	11-2	CR
258-0472-00	Wire	.125 sq		DL
258-0488-00	Strip	.0108 x 1.250	11-2	CS
258-0490-00	Sheet	.00675 x 30.000	11-2	CR
258-0491-00	Bar	.125 x 2.000	11-2	CS
258-0493-00	Foil	.002 x 1.000	11-2	CR
258-0513-00	Wire	.006 dia	11-2	CR
258-0518-00	Wire	.0216 x 1.125	11-2	CR
258-0533-00	Wire	.188 dia	11-2	CR

§§ STATUS CODES

CR	Current Production
EN	Engineering
PP	Pre-Production
CS	Customer Service
NP	Non-Production
DL	Deleted
OB	Obsolete Instrument
CM	Custom Mod Instrument
DS	Digital Systems
OT	Obsolescent Instrument
MP	Modified Part
LR	Last Supply Current
LS	Last Supply Customer Service
VN	Vendor
TC	Tequipment Current Production
IN	International
SC	Sony/Tek Current Production

THE STATUS IN THIS CATALOG WAS CORRECT AT THE TIME IT WAS PUBLISHED, BUT IT IS SUBJECT TO CHANGE.

§ TO USE A PART WITH THIS STATUS ON A NEW INSTRUMENT REQUIRES THAT A NEW PURCHASED PART INITIATION FORM (PPIF) BE INITIATED.

(A GLOSSARY OF TERMS FOR THESE STATUS CODES CAN BE FOUND ON PAGE 0-10).

COST CODE

(CC COLUMN)

CODE	≈ VALUE with -	≈ VALUE no suffix	≈ VALUE with +
A	.2¢	.5¢	.75¢
B	1.25¢	1.5¢	2¢
C	2.5¢	3¢	3.75¢
D	4.25¢	5¢	6¢
E	7¢	8¢	10¢
F	13¢	15¢	18¢
G	22¢	25¢	35¢
H	40¢	50¢	60¢
I	65¢	75¢	\$1
J	\$1.25	\$1.50	\$2
K	\$2.50	\$3	\$3.75
L	\$4.25	\$5	\$6
M	\$7	\$8	\$10
N	\$13	\$15	\$18
O	\$22	\$25	\$35+

NOTE: Costs may vary from order to order due to order quantities, vendor, etc.

ITEM	QTY	UNIT PRICE	TOTAL PRICE	DESCRIPTION
101	100	1.00	100.00	...
102	200	2.00	400.00	...
103	300	3.00	900.00	...
104	400	4.00	1600.00	...
105	500	5.00	2500.00	...
106	600	6.00	3600.00	...
107	700	7.00	4900.00	...
108	800	8.00	6400.00	...
109	900	9.00	8100.00	...
110	1000	10.00	10000.00	...
111	1100	11.00	12100.00	...
112	1200	12.00	14400.00	...
113	1300	13.00	16900.00	...
114	1400	14.00	19600.00	...
115	1500	15.00	22500.00	...
116	1600	16.00	25600.00	...
117	1700	17.00	28900.00	...
118	1800	18.00	32400.00	...
119	1900	19.00	36100.00	...
120	2000	20.00	40000.00	...

COST CODE
(CC COLUMN)

CODE	VALUE	VALUE	VALUE
101	1.00	2.00	3.00
102	4.00	5.00	6.00
103	7.00	8.00	9.00
104	10.00	11.00	12.00
105	13.00	14.00	15.00
106	16.00	17.00	18.00
107	19.00	20.00	21.00
108	22.00	23.00	24.00
109	25.00	26.00	27.00
110	28.00	29.00	30.00

COST CODE
(CC COLUMN)

CODE	A	B	C	D	E	F	G	H	I	J	K	L	M	N	O
~ VALUE with +	.75¢	2¢	3.75¢	6¢	10¢	18¢	35¢	60¢	\$1	\$2	\$3.75	\$6	\$10	\$18	\$35+
~ VALUE no suffix	.5¢	1.5¢	3¢	5¢	8¢	15¢	25¢	50¢	75¢	\$1.50	\$3	\$5	\$8	\$15	\$25
~ VALUE with -	.2¢	1.25¢	2.5¢	4.25¢	7¢	13¢	22¢	40¢	65¢	\$1.25	\$2.50	\$4.25	\$7	\$13	\$22

NOTE: Costs may vary from order to order due to order quantities, vendor, etc.

COPPER (CONT)

+ ASTM B152

TENSILE STRENGTH REQUIREMENTS AND APPROXIMATE ROCKWELL HARDNESS VALUES FOR ROLLED TEMPER.

TEMPER STANDARD DESIGNATION	TEMPER FORMER DESIGNATION	TENSILE STRENGTH KSI*		YIELD STRENGTH KSI*		APPROXIMATE ROCKWELL HARDNESS ¹			
						F SCALE		SUPERFICIAL 30T	
		MIN	MAX	MIN	MAX	MIN	MAX	MIN	MAX
	COLD-ROLLED TEMPER:								
H00	Eighth Hard	32	40			54	82	--	49
H01	Quarter Hard	34	42	26	39	60	84	18	51
H02	Half Hard	37	46	39	44	77	89	43	57
H03	Three-quarter Hard	41	50	39	48	82	91	47	59
H04	Hard	43	52	41	50	86	93	54	62
H06	Extra Hard	47	56	46	55	88	95	56	64
H08	Spring	50	58	48	57	91	97	60	66
H10	Extra Spring	52		51		92	--	61	--
	HOT-ROLLED TEMPER:								
M20	Hot-Rolled	30	38			--	75	--	41
O25	Hot-rolled & annealed	30	38			--	65	--	31

¹ ROCKWELL VALUES APPLY AS FOLLOWS: THE F SCALE APPLIES TO METAL 0.020 IN. (0.508 mm) AND OVER IN THICKNESS. THE SUPERFICIAL 30-T SCALE APPLIES TO METAL 0.012 IN. (0.305 mm) AND OVER IN THICKNESS.

+ ASTM B301

TEMPER	DIAMETER OR DISTANCE BETWEEN PARALLEL	TENSILE STRENGTH MIN PSI	YIELD STRENGTH ² MIN PSI	ELONGATION IN 4 X DIAMETER OR THICKNESS OF SPECIMEN ³ MIN, PERCENT
HALF-HARD	.0625 TO .25	38,000	30,000	8
	OVER .25 TO 2.625	38,000	30,000	12
HARD	.0625 TO .25	48,000	40,000	4
	OVER .25 TO 1.25	44,000	38,000	8
	OVER 1.25 TO 2.	40,000	35,000	8
	OVER .188 TO .375	42,000	35,000	10
	OVER .375 TO .5	40,000	32,000	10
	OVER .5 TO .2	33,000	18,000	12
	OVER 2. TO 4.	32,000	15,000	12

² NOT DETERMINED UNLESS SPECIFICALLY REQUESTED.

³ IN ANY CASE A MINIMUM GAGE LENGTH OF 1 INCH SHALL BE USED.

+ The dimensions and tolerances for material covered by B301 specification can be found in Specification ASTM B249; specification B152 can be found in Specification ASTM B248. (see pages 12-12 & 12-15)

+ The full text of this ASTM is available for review at 78-567, or, for more information, call Norma, Ext. 2577, or Comp. Eval., Bella Geotina, Ext. 2315.

*KSI = 1000 psi

COPPER (CONT)

MECHANICAL PROPERTIES & TOLERANCES (PER ASTM B111)

COPPER OR COPPER ALLOY NO.	TEMPER		TENSILE STRENGTH MIN		YIELD STRENGTH, MIN		ELONGATION IN 2 IN (50.8mm) MIN %
	NEW DESIGNATION	FORMER DESIGNATION	KSI	MPa	KSI	MPa	
C10100, C10200, C10300, C10800, 12000, C12200, C14200.	H55	light-drawn	36	250	30	205	
C10100, C10200, C10300, C10800, 12000, 12200, C14200.	H80	hard-drawn	45	310	40	275	
C19200	H55	light-drawn	40	275	35	240	
C19200	H80	hard-drawn	48	330	43	295	
C19200	O61	annealed	38	260	12	85	
C23000	O61	annealed	40	275	12	85	
28000	O61	annealed	50	345	20	140	
C44300, C44400, C44500.	O61	annealed	45	310	15	105	
C60800	O61	annealed	50	345	19	130	
C61400	O61	annealed	70	480	30	205	
C68700	O61	annealed	50	345	18	125	
C70400	O61	annealed	38	260	12	85	
C70400	H55	light-drawn	40	275	30	205	
C70600	O61	annealed	40	275	15	105	
C70600	H55	light-drawn	45	310	35	240	
C71000	O61	annealed	45	310	16	110	
C17500	O61	annealed	52	360	18	125	
C71500							
Wall thickness up to 0.048 in. (1.21 mm), incl.	HR50	drawn, stress-relieved	72	495	50	345	12
Wall thickness over 0.048 in. (1.21 mm).	HR50	drawn, stress-relieved	72	495	50	345	15

DIAMETER TOLERANCES

OUTSIDE DIAMETER, IN. (mm)	WALL THICKNESS, IN. (mm)				
	0.020 (0.508) ³ 0.022 (0.559) 0.025 (0.635) 0.028 (0.711)	0.032 (0.813)	0.035 (0.889)	0.042 (1.07)	0.049 (1.24) and over
DIAMETER TOLERANCE, PLUS AND MINUS, IN. (mm)					
Up to 0.500 (12.7), incl.	0.003 (0.076)	0.0025 (0.064)	0.0025 (0.064)	0.0025 (0.064)	0.0025 (0.064)
Over 0.500 (12.7) to 0.740 (18.8) incl	0.0040 (0.10)	0.004 (0.10)	0.004 (0.10)	0.0035 (0.089)	0.003 (0.076)
Over 0.740 (18.8) to 1.000 (25.4) incl	0.0060 (0.15)	0.006 (0.15)	0.005 (0.13)	0.0045 (0.11)	0.004 (0.10)
Over 1.000 (25.4) to 1.250 (31.8) incl	---	0.009 (0.23)	0.008 (0.20)	0.006 (0.15)	0.0045 (0.11)
Over 1.250 (31.8) to 1.375 (34.9) incl	---	---	---	0.008 (0.20)	0.005 (0.13)
Over 1.375 (34.9) to 2.000 (50.8) incl	---	---	---	---	---

WALL THICKNESS TOLERANCES, PLUS AND MINUS IN. (MM)

WALL THICKNESS, IN. (mm)	OUTSIDE DIAMETER, IN. (mm)		
	Over 1/8 (3.18) to 5/8 (15.9), incl.	Over 5/8 (15.9) to 1 (25.4), incl.	Over 1 (25.4) to 2 (50.8), incl.
0.020 (0.506), incl. to 0.032 (0.813)	0.003 (0.076)	0.003 (0.076)	---
0.032 (0.813), incl. to 0.035 (0.889)	0.003 (0.076)	0.003 (0.076)	0.004 (0.10)
0.035 (0.889), incl. to 0.058 (1.47)	0.004 (0.10)	0.0045 (0.11)	0.0045 (0.11)
0.058 (1.47), incl. to 0.083 (2.11)	0.0045 (0.11)	0.005 (0.13)	0.005 (0.13)
0.083 (2.11), incl. to 0.120 (3.05)	0.005 (0.13)	0.0065 (0.17)	0.0065 (0.17)
0.120 (3.05), incl. to 0.134 (3.40)	0.007 (0.18)	0.007 (0.18)	0.0075 (0.19)

¹ At 0.5% extension under load.

² KSI = 1000 psi.

³ Tolerances in this column are applicable to light drawn and drawn tempers only. Tolerances for annealed tempers shall be as agreed upon between the manufacturer and purchaser.

COPPER (CONT)

WEIGHT (LBS PER FT)

ASTM B152, ALLOY C11000

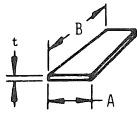

SOFT SHEET COPPER

WEIGHT PER SQUARE FOOT		THICKNESS "t" INCHES	WIDTH "A" INCHES	LENGTH "B" INCHES	POUNDS PER SHEET
OUNCES	POUNDS				
12	.750	.0162	36	96	18.0
14	.875	.0189	30	96	17.5
14	.875	.0189	36	96	21.0
16	1.00	.0216	24	120	20.0
16	1.00	.0216	24	96	16.0
16	1.00	.0216	30	120	30.0
16	1.00	.0216	30	96	20.0
16	1.00	.0216	36	120	30.0
16	1.00	.0216	36	96	24.0
18	1.125	.0243	30	96	22.5
18	1.125	.0243	36	96	27.0
18	1.125	.0243	36	120	33.7
20	1.25	.027	30	96	25.0
20	1.25	.027	36	120	37.5
20	1.25	.027	36	96	30.0
24	1.50	.0323	30	96	30.0
24	1.50	.0323	36	120	45.0
24	1.50	.0323	36	96	36.0
24	1.50	.0323	48	96	48.0
32	2.00	.0431	30	96	40.0
32	2.00	.0431	30	120	50.0
32	2.00	.0431	36	120	60.0
32	2.00	.0431	36	96	48.0
-	2.37	.051	36	96	56.9
40	2.50	.0239	36	96	60.0
48	3.00	.0647	30	96	60.0
48	3.00	.0647	36	96	72.0
-	4.36	.0937	36	96	105.
-	5.81	.125	30	96	116.
-	5.81	.125	36	96	139.

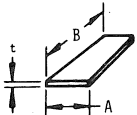

COLD ROLLED SHEET COPPER

WEIGHT PER SQUARE FOOT		THICKNESS "t" INCHES	WIDTH "A" INCHES	LENGTH "B" INCHES	POUNDS PER SHEET
OUNCES	POUNDS				
14	.875	.0189	30	96	17.5
14	.875	.0189	36	96	21.0
16	1.0	.0216	24	120	20.0
16	1.0	.0216	24	96	16.0
16	1.0	.0216	30	120	25.0
16	1.0	.0216	30	96	20.0
16	1.0	.0216	36	120	30.0
16	1.0	.0216	36	96	24.0
18	1.125	.0243	30	96	22.5
18	1.125	.0243	36	96	27.0
20	1.25	.027	24	120	25.0
20	1.25	.027	30	96	25.0
20	1.25	.027	30	120	31.2
20	1.25	.027	36	120	37.5
20	1.25	.027	36	96	30.0
24	1.50	.0323	30	96	30.0
24	1.50	.0323	36	120	45.0
24	1.50	.0323	36	96	36.0
24	1.50	.0323	48	120	60.0
32	2.00	.0431	30	96	40.0
32	2.00	.0431	36	120	60.0
32	2.00	.0431	36	96	48.0
40	2.50	.0539	36	96	60.0
48	3.00	.0647	30	96	60.0
48	3.00	.0647	36	96	72.0
48	3.00	.0647	48	96	96.0
-	4.36	.0937	36	96	105.
-	5.81	.125	36	96	139.
-	5.81	.125	48	96	186.
-	8.72	.1875	36	96	209.
-	11.63	.250	36	96	279.

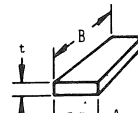

HEAVY COPPER PLATE
Cold Rolled Temper

THICKNESS "t" INCHES	WIDTH "A" INCHES	LENGTH "B" INCHES	POUNDS SQUARE INCH	POUNDS SQUARE FOOT
3/16	12	96 & 120	.061	8.72
3/16	36	96 & 120	.061	8.72
1/4	12	96 & 120	.081	11.6
1/4	36	96 & 120	.081	11.6
3/8	12	96 & 120	.121	17.4
3/8	36	96 & 120	.121	17.4
1/2	12	96 & 120	.161	23.2
1/2	36	96 & 120	.161	23.2
5/8	12	96 & 120	.201	28.9
5/8	36	96 & 120	.201	28.9
3/4	8	96 & 120	.242	34.8
3/4	12	96 & 120	.242	34.8
3/4	36	96 & 120	.242	34.8
1	7	96 & 120	.323	46.5
1	8	96 & 120	.323	46.5
1	9	96 & 120	.323	46.5
1	10	96 & 120	.323	46.5
1	12	96 & 120	.323	46.5
1	36	96 & 120	.323	46.5
1-1/4	5	96 & 120	.403	58.0
1-1/4	6	96 & 120	.403	58.0
1-1/4	8	96 & 120	.403	58.0
1-1/4	10	96 & 120	.403	58.0
1-1/4	12	96 & 120	.403	58.0
1-1/4	36	96 & 120	.403	58.0
1-3/8	36	96	.444	63.9
1-1/2	5	96 & 120	.483	69.6
1-1/2	6	96 & 120	.483	69.6
1-1/2	8	96 & 120	.483	69.6
1-1/2	10	96 & 120	.483	69.6
1-1/2	12	96 & 120	.483	69.6
1-1/2	36	96 & 120	.483	69.6
1-3/4	12	96 & 120	.563	81.1
1-3/4	12	96 & 120	.563	81.1
1-3/4	36	96 & 120	.563	81.1
2	5	96 & 120	.645	92.9
2	6	96 & 120	.645	92.9
2	8	96 & 120	.645	92.9
2	10	96 & 120	.645	92.9
2	12	96 & 120	.645	92.9
2	36	96 & 120	.645	92.9
2-1/4	36	96	.727	105.
2-1/2	4	96 & 120	.805	116.
2-1/2	5	96 & 120	.805	116.
2-1/2	6	96 & 120	.805	116.
2-1/2	10	96	.805	116.
2-1/2	12	96	.805	116.
2-1/2	36	96	.805	116.
3	4	96 & 120	.965	139.
3	6	96 & 120	.965	139.
3	10	96	.965	139.
3	12	96	.965	139.
3	24	96	.965	139.
3-1/2	6	96 & 120	1.13	163.
3-1/2	10	96	1.13	163.
3-1/2	12	96	1.13	163.
3-1/2	24	96	1.13	163.
4	5	96 & 120	1.29	186.
4	10	96	1.29	186.
4	12	96	1.29	186.
4	24	96	1.29	186.
5	23	82	1.62	233.
5	24	96	1.62	233.

COPPER (CONT)

WEIGHT (LBS PER FT)

ASTM B152, ALLOY C11000

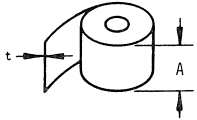

SOFT COPPER IN ROLLS

THICKNESS "t"		WIDTH "A" INCHES	POUNDS LINEAL FOOT
IN INCHES	FRACTION OR B & S GAUGE		
.002	44 ga.	2	.016
.0031	40 ga.	3	.036
.0031	40 ga.	6	.072
.004	38 ga.	9	.140
.004	38 ga.	12	.186
.0042	-	25	.406
.005	36 ga.	1-1/4	.024
.005	36 ga.	2	.039
.005	36 ga.	3	.058
.005	36 ga.	12	.233
.008	32 ga.	12	.372
.010	30 ga.	3	.116
.010	30 ga.	4	.155
.010	30 ga.	6	.233
.010	30 ga.	12	.465
.0126	28 ga.	12	.586
.013	28 ga.	12	.605
.0159	26 ga.	12	.739
.0201	24 ga.	12	.935
.0216	-	6	.500
.0216	-	7	.583
.0216	-	8	.667
.0216	-	10	.833
.0216	-	12	1.00
.0216	-	14	1.17
.0216	-	16	1.33
.0216	-	18	1.50
.0216	-	20	1.67
.0253	22 ga.	12	1.18
.032	20 ga.	12	1.49
.0403	18 ga.	12	1.87
.043	-	12	2.00
.0453	17 ga.	12	2.11
.0508	16 ga.	8	1.57
.0508	16 ga.	12	2.36
.0625	1/16	12	2.91
.0641	14 ga.	12	2.98

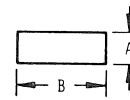

SOFT COPPER STRIP

THICKNESS "t"		WIDTH "B" INCHES	LENGTH "A" INCHES	POUNDS SQUARE FOOT
IN	FRACTION OR B & S GAUGE			
.032	20 ga.	12	96	1.49
.0403	18 ga.	12	96	1.87
.0508	16 ga.	12	96	2.36
.0625	1/16	12	96	2.91
.072	13 ga.	12	96	3.35
.0808	12 ga.	12	96	3.76
.093	3/32	12	96	4.32
.125	1/8	12	96	5.81

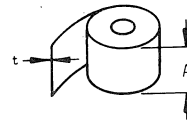

HALF HARD COPPER IN ROLLS

THICKNESS "t"		WIDTH "A" INCHES	POUNDS LINEAL FOOT
IN INCHES	FRACTION OR B & S GAUGE		
.005	36 ga.	1-3/8	.026
.005	36 ga.	2	.039
.005	36 ga.	3	.058
.005	36 ga.	6	.116
.005	36 ga.	12	.233
.0071	33 ga.	4	.110
.0071	33 ga.	12	.330
.010	30 ga.	2	.077
.010	30 ga.	3	.116
.010	30 ga.	4	.155
.010	30 ga.	6	.232
.010	30 ga.	12	.465
.0126	28 ga.	12	.586
.0159	26 ga.	12	.739
.0201	24 ga.	12	.935
.0216	-	8	.667
.0253	22 ga.	12	1.18
.032	20 ga.	12	1.49
.0403	18 ga.	12	1.87
.0453	17 ga.	12	2.11
.0508	16 ga.	12	2.36
.0641	14 ga.	12	2.98

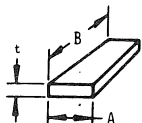

HALF HARD COPPER STRIP AND PLATE

THICKNESS "t"		WIDTH "A" INCHES	LENGTH "B" INCHES	POUNDS SQUARE INCH	POUNDS SQUARE FOOT
IN INCHES	FRACTION OR B & S GAUGE				
.032	20 ga.	12	96	.010	1.49
.032	20 ga.	18	144	.010	1.49
.0403	18 ga.	12	96	.013	1.87
.0508	16 ga.	12	96	.016	2.36
.0625	1/16	6	96	.020	2.91
.0625	1/16	12	96	.020	2.91
.0641	14 ga.	12	96	.021	2.98
.0808	12 ga.	12	96	.026	3.76
.0937	3/32	12	96	.030	4.36
.125	1/8	12	96	.040	5.81
.1875	3/16	12	96	.061	8.72
.250	1/4	12	96	.081	11.6
.375	3/8	12	96	.121	17.4
.500	1/2	12	96	.162	23.3
.625	5/8	12	96	.202	29.1
.750	3/4	12	96	.242	34.9
1.00	1	12	96	.323	46.5
1.25	1-1/4	12	96	.404	58.1
1.375	1-3/8	12	96	.444	64.0
1.500	1-1/2	12	96	.485	69.8
1.75	1-3/4	12	96	.565	81.4
2.00	2	12	96	.646	93.0
2.25	2-1/4	12	96	.727	105.
2.50	2-1/2	12	96	.808	116.
2.75	2-3/4	12	96	.888	128.
3.00	3	12	96	.969	140.
3.50	3-1/2	12	96	1.13	163.
4.00	4	12	96	1.29	186.

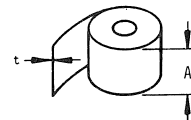

HARD COPPER IN ROLLS

THICKNESS "t"		WIDTH "A" INCHES	POUNDS LINEAL FOOT
IN INCHES	FRACTION OR B & S GAUGE		
.005	36 ga.	1-1/4	.024
.005	36 ga.	1-1/2	.029
.005	36 ga.	2	.039
.005	36 ga.	2-1/2	.048
.005	36 ga.	6	.116
.005	36 ga.	12	.233
.010	30 ga.	12	.465
.0159	26 ga.	12	.739
.0253	22 ga.	12	1.18
.032	20 ga.	12	1.49
.0403	18 ga.	12	1.87
.0453	17 ga.	12	2.11
.0508	16 ga.	12	2.36

11

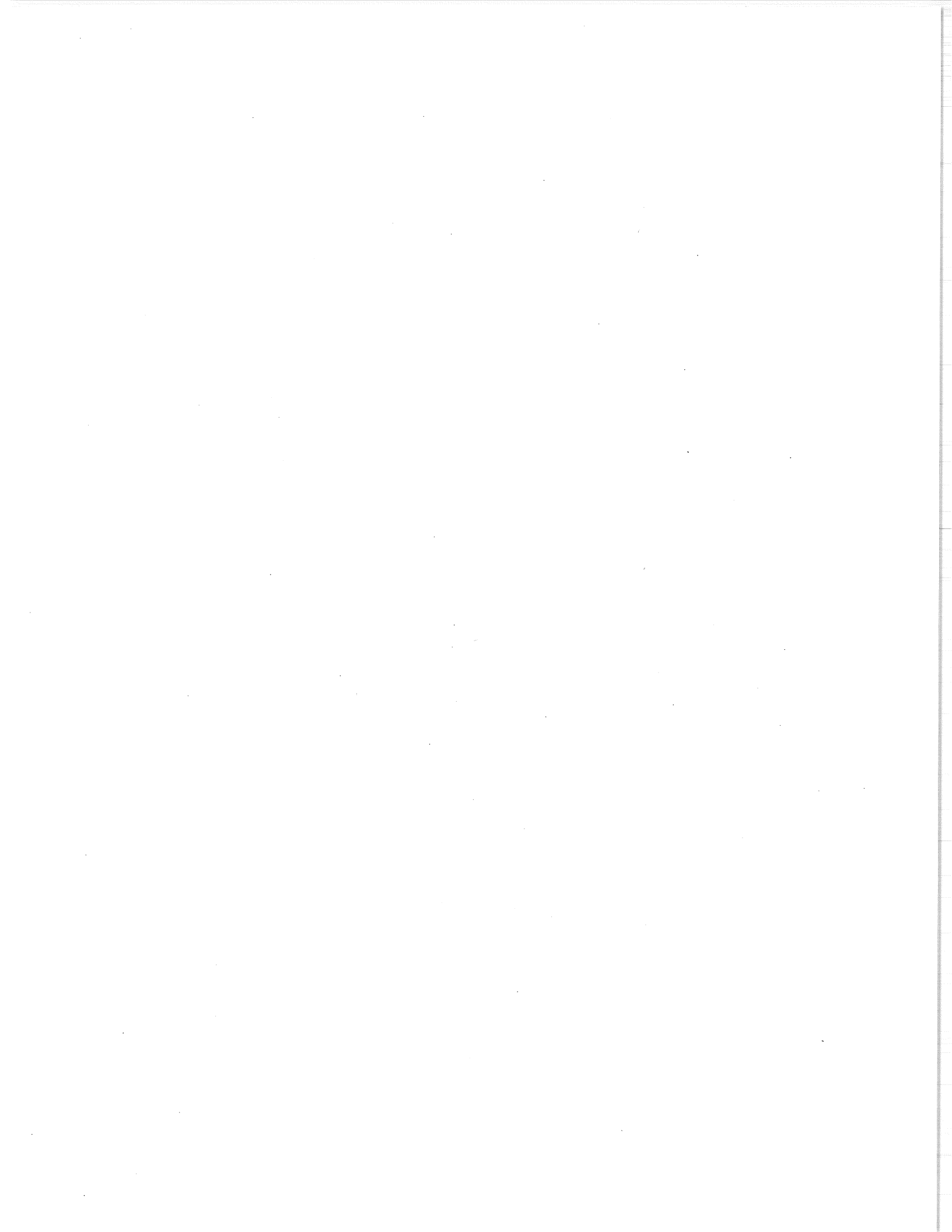

MATERIAL NAMES:

The standard used at Tek for naming parts is H6 (Cataloging Handbook). In some cases, the ASTM uses different names than H6. In such cases the H6 name will be used.

NAME	SHAPE
BAR	<p>(also Hex, Dodecagon, etc)</p> <p>$\geq .375$ (≥ 9.525 mm)</p> <p>$\geq .375$ (≥ 9.525 mm)</p> <p>$\geq .375$ (≥ 9.525 mm)</p> <p>$\geq .375$ (≥ 9.525 mm)</p> <p>$\geq .375$ (≥ 9.525 mm)</p> <p>$\geq .375$ (≥ 9.525 mm)</p> <p>$\geq .094$ (≥ 2.381 mm)</p> <p>.375 to 12" (9.525 to 304.8 mm)</p>
ROD	DO NOT USE FOR METALS (Deleted from H6)
STRIP	<p>1.25 to 12" (31.75 mm to 304.8 mm)</p> <p>$> .005$ ($> .132$ mm) $< .094$ (< 2.381 mm)</p>
*WIRE & *ROD	<p>(also Hex, Dodecagon, etc)</p> <p>$< .375$ (≥ 9.525 mm)</p> <p>$< .375$ (≥ 9.525 mm)</p> <p>$< .375$ (≥ 9.525 mm)</p> <p>$< .375$ (≥ 9.525 mm)</p> <p>$< .375$ (≥ 9.525 mm)</p> <p>$< .375$ (≥ 9.525 mm)</p> <p>$< .375$ (≥ 9.525 mm)</p> <p>$< .094$ ($> .132$ mm) $> .005$ (< 2.381 mm)</p> <p>< 1.250 (< 31.75 mm)</p> <p>*Use WIRE for metal, and ROD for nonmetallic parts.</p>
SHEET	<p>$> 12"$ across narrowest flats. (> 304.8 mm)</p> <p>$> .005$ ($> .132$ mm)</p>
FOIL & **FILM	<p>any width</p> <p>$\leq .005$ ($\leq .132$ mm)</p> <p>Use FOIL for metal, and FILM for nonmetallic parts.</p>

Some materials do not yet have specifications and may change without notice until the spec is finished. Also, some are exclusively used by one department and may be changed without notice by them.

MISC COPPER, BERYLLIUM & NICKEL ALLOYS, SOLDER & FLUX, PRECIOUS METALS, SILICON WAFERS & PURCH. FRONT PANELS

SECTION 12

TABLE OF CONTENTS

	PAGE (S)
COPPER-NICKEL-ZINC	12-2
NICKEL-CHROMIUM-IRON SEALING ALLOY	12-3
IRON-NICKEL-COBALT SEALING ALLOY	12-4
MISCELLANEOUS METALS	12-5
MISCELLANEOUS PRECIOUS METALS	12-6
SILICON WAFERS	12-6
FRONT PANELS	12-7
SOLDER & FLUX	12-8 & 12-9
CROSS REFERENCE INDEX	12-10 & 12-11
TOLERANCES	12-12 THRU 12-23
NOTES	12-24

TEK STANDARDS PERTAINING TO MATERIALS

062-1702-00	Welding, Soldering & Brazing	D-100	Die Casting & Molding Standards
062-1703-00	Finishes, Glossary of Terms		
062-1713-00	Drafting, Aluminum Extrusions	H Series	Tooling Standards
062-1718-00	Finish Quality, Cosmetic		
062-2845-00	Mechanically Applied Finishes		
062-2848-00	Bend Allowance & Deduction		
062-2850-00	Finish, Surface Texture	062-5818-01	Aluminum (M150)
062-2854-00	Finishes, Chemical & Electromechanical	M-200	Brass
062-2856-00	Non-Additive Finishes for Brass, Copper & Copper Alloys	M-250	Copper
062-2860-00	Finishes, Anodized	M-300	Copper-Beryllium
062-2863-00	Zinc Die Cast Finishes, Chromate Conversion Coatings	M-350	Beryllium-Nickel
062-2868-00	Finish, Etch Chromate & Lacquer (On Aluminum)	M-400	Phosphor-Bronze
062-2868-01	Chromate Conversion Coating for Al Die Casting Alloy 3431	M-450	Steel
062-2871-00	Finish, Passivating	M-500	Stainless Steel
062-5818-00	General Information about Bulk Raw Materials	M-550	Magnetic Shielding Materials (Iron-Nickel & Nickel-Silver)
		M-600	Copper-Nickel-Zinc

COST CODE

(CC COLUMN)

CODE	A	B	C	D	E	F	G	H	I	J	K	L	M	N	O
≈ VALUE with +	.75¢	2¢	3.75¢	6¢	10¢	18¢	35¢	60¢	\$1	\$2	\$3.75	\$6	\$10	\$18	\$35+
≈ VALUE no suffix	.5¢	1.5¢	3¢	5¢	8¢	15¢	25¢	50¢	75¢	\$1.50	\$3	\$5	\$8	\$15	\$25
≈ VALUE with -	.2¢	1.25¢	2.5¢	4.25¢	7¢	13¢	22¢	40¢	65¢	\$1.25	\$2.50	\$4.25	\$7	\$13	\$22

NOTE: Costs may vary from order to order due to order quantities, vendor, etc.

MISCELLANEOUS METALS

COPPER-NICKEL-ZINC

ASTM B122 ALLOY C75200

SIZE	ALLOY	TEMPER	SPECIFICATION (ASTM)	TOLERANCES** (ASTM)	PART NUMBER	CC	OTHER
STRIP .0359 ± .0025 x 6.000	C75200	Soft	B122	B248	258-0319-00	1b K-	18% Nickel
SHEET .025 x 24.000 x 96.000	C75200	One-half Hard	B122	B248	258-0355-00	1b J+	
.049 x 12.000 or 24.000 x 96.000	C75200	One-half Hard	B122	B248	258-0354-00	1b J+	
WIRE .015 x .188	C75200	One-qtr Hard	B122	B248	258-0357-00	1b K	
.025 x .188	C75200	One-qtr Hard	B122	B248	258-0355-01	1b J+	

TEMPER		TENSILE STRENGTH PSI		APPROXIMATE ROCKWELL HARDNESS			
				B SCALE		SUPERFICIAL 30-T	
STANDARD DESIGNATION	FORMER DESIGNATION	MIN	MAX	MIN	MAX	MIN	MAX
H01	Quarter Hard	58,000	72,000	50	75	49	67
H02	Half Hard	66,000	80,000	68	82	62	72
H04	Hard	78,000	91,000	80	90	70	76
H06	Extra Hard	86,000	98,000	87	94	74	79
H08	Spring	90,000	101,000	89	96	75	80

A guide for the selection and use of beryllium-copper and beryllium-nickel alloys is available from the Metallurgical Lab. These two alloys are among the most widely used at Tek for producing springs, contact switches, retainer clips and other similar components.

The guidelines were written by Kwaku Mensah, and describe the electrical and mechanical properties of the alloys, as well as the advantages and disadvantages associated with each. Selection and factors are based on electrical and thermal conductivity, yield strength, corrosion and wear resistance, fatigue and impact strength and other criteria.

To make the best choice of materials, it is important that designers be aware of the unique properties of these alloys. If you would like a copy of the selection guidelines, send your request to the Metallurgical Lab (38-314).

MISCELLANEOUS METALS

NICKEL-CHROMIUM-IRON SEALING ALLOY

PER ASTM F31

SIZE	TEMPER	PART NUMBER	CC	
.025 x .125	Annealed	251-0841-00	G+	oz
.025 x .125		258-0422-00	L	1b
.025 x 8.000		251-0994-00	L-	1b

ALLOY 426

CHEMICAL COMPOSITION %	
ELEMENT	COMPOSITION PERCENT
Nickel	42 Nom.
Chromium	5.6 Nom.
Carbon	.07 Max
Manganese	.25 Max
Phosphorus	.025 Max
Sulphur	.025 Max
Silicon	.3 Max
Aluminum	.2 Max
Iron	Balance

THERMAL EXPANSION	
TEMPERATURE RANGE, °C	COEFFICIENT $\mu\text{m}/\text{m}\cdot^\circ\text{C}$
30-350°C (86 to 662°F)	8.5 to 9.2
30-425°C (86 to 797°F)	9.7 to 10.4

PHYSICAL PROPERTIES		
Density	8.12 gm/cc	.294 lb/cu in
Melting Point	1425°C	2597°F
Thermal Conductivity at 20-100°C (68 to 212°F)	.029 gm, cal/sq. cm/sec/°C/cm .023 Btu/sq. ft/sec/°F/in	
Electrical Resistivity 20°C (68°F)	95 microhm/sq. cm/cm	570 ohms/circ. mil/ft
Curie Temperature	295°C	563°F

MECHANICAL PROPERTIES (ANNEALED)		
Tensile Strength	56.2 kg/sq. mm	80,000 psi
Yield Strength, .2% offset	28.1 kg/sq. mm	40,000 psi
Elongation, % in 2 in (5.08 cm)	30	
Reduction in Area (percent)	70	
Hardness (Rockwell 15T)	86	
Modulus of Elasticity	16.2×10^3 kg/sq. mm	23×10^6 psi
Poisson's Ratio	.28	

12

MISCELLANEOUS METALS

IRON-NICKEL-COBALT SEALING ALLOY

PER ASTM F15

SIZE *	TEMPER	FINISH	PART NUMBER	CC
FOIL .003 x .062 .003 ± .0005 x 6.5 .005 ± .0005 x 8.	Annealed Annealed	Mill Belt Polish	258-0364-00 258-0332-00 258-0446-00	A ft L lb M lb
STRIP .01 ± .0005 x 8.	Annealed	Mill	258-0370-00	L Sheet
TUBE .088 ± .002 OD x .0255 ± .001 ID x 6 ft. 1g	1/8 - 1/4 Hard	Cold-drawn	251-0680-00	J+ ft

TENSILE PROPERTIES

Typical values representing results obtained at various temperatures with a strain rate of 800%/hour.					
TEMP °C	.5% YIELD STRENGTH PSI	ULTIMATE STRENGTH PSI	UNIFORM ELONG %	TOTAL ELONG %	REDUCTION OF AREA %
21	59,500	77,500	16.78	35.4	69.
213	39,000	58,500	18.59	32.08	73.2
308	32,500	54,500	22.12	34.79	65.2
400	30,000	50,000	20.9	36.33	74.
500	26,500	42,000	21.69	33.96	71.
600	23,500	36,000	19.45	28.4	35.
738	21,500	25,000	6.87	18.23	25.
790	17,100	19,000	5.21	14.65	21.6

MAGNETIC PROPERTIES

MAGNETIC LOSSES				
THICKNESS, INCHES	MAGNETIC LOSSES, WATTS PER POUND			
	10 kg 60 cps	10 kg 840 cps	2 kg 5000 cps	2 kg 10,000 cps
.01	1.05	23.4	16.6	41.
.03	1.51	-	-	-
.05	2.77	-	-	-

MAGNETIC PERMEABILITY

FLUX DENSITY (GAUSSES)	MAGNETIC PERMEABILITY
500	1000
2000	2000
7000	3700 (max value)
12000	2280
17000	213

THERMAL EXPANSION

After annealing in hydrogen for one hour at 900°C and fifteen minutes at 1100°C, the average linear coefficient of expansion will fall within specified limits below.	
TEMPERATURE RANGE, °C	AVERAGE LINEAR COEFFICIENT OF EXPANSION μm/m.°C
SPECIFIED LIMITS	
30-500	4.6 to 5.2
30-450	5.1 to 5.5
TYPICAL EXPANSION DATA	
30-200	5.5
30-300	5.1
30-400	4.9
30-450	5.3
30-500	6.2
30-600	7.9
30-700	9.3
30-800	10.4
30-900	11.5

ELECTRICAL RESISTIVITY

Typical resistance at 25°C - 49 microhms/cm - 294 ohms/cir mil foot	
Although close tolerances are not guaranteed on the electrical properties, these are expected to be fairly uniform due to the close limits set on chemical composition.	
Listed below are results of a typical test.	
TEMPERATURE, °C	RELATIVE RESISTANCE
25	1.
100	1.28
200	1.64
300	1.97
400	2.19
500	2.31
600	2.38

MISCELLANEOUS METALS

PART NUMBER	MATERIAL	SIZE	OTHER	CC
251-0419-00	Iron Cr. Al.	.020 x 1.500 x 10/12 ft. long	±20 PPM, .02125 _μ /ft. ± 1%	1b L
251-0419-01	Iron Cr. Al.	.0186 x 1.750	Alloy 815, ±20 PPM, .02125 _μ /ft ± 5%	1b M+
251-0508-00	Tin Bar			1b M+
251-0555-00	Inconel Nickel Alloy 600	.020 x .125	Ni. Alloy, Rockwell Sprficial. 15N 78-80 Sprng	1n A
251-0570-00	Steel Wire, Tinned	.006 x .187		1b K
251-0702-00	Monel Strip	.020 x 2.625	Rockwell 15 T 75-85	1b M
251-0736-00	Monel K500	.003 x 6.000	One-half Hard	1b O+
251-0737-00	Monel K500	.005 x 6.000	One-half Hard	1b O+
251-0740-00	Iron Ingot	.020 ± .001 x .250 ± .005		1b I+
251-0745-00	Tin-Lead Foil	.0004 x .250		1b M+
251-0760-00	Tin-Lead Foil	.0004 x .625		oz I-
251-0819-00	Nickel Foil	.002 x .050		1b O-
251-0833-00	Nickel Foil 600 Ribbon	.005 x .125	Spring temper, Rockwell 15N 76.500 Min	oz I+
251-0840-00	Nickel Foil 600 Ribbon	.005 x .100	Spring temper, Rockwell 15N 78-80	1b N+
251-0846-00	Nickel Foil	.005 x 2.000	Annealed, ultrabrite finish, Alloy 200, ASTM B162	1b N-
251-0854-00	Tin-Lead Foil	.00025 x .375		1b M
251-0872-00	Nickel	.080 x .045	Round edge, annealed	1b O+
251-0898-00	Nickel Foil	.005 x 2.200	ASTM B162 #7.5 micro-grain size or smaller, mirror finish, annealed	1b M-
251-0902-00	Nickel Foil	.002 x .250	One-quarter Hard	1b O-
251-0990-00	Iron-Nickel Strip	.015 x 4.500	Carpenter 49FM	1b L
251-0996-00	Iron-Nickel Bar	1.000 dia.	Carpenter Hi Perm	1b L
251-3023-00	Tungsten Carbide Wire	.008 sia. x 2.000 long	Rockwell A-92	ea K+
251-3030-00	Zinc Alloy Ingot	1.375 x 2.688 x 24.000 long	Alloy AG40A 4-Section (ASTM B240)	1b H
251-3061-00	Nickel Chrome Strip	.010 x 3.500	Alloy X-750 AMS-5541, bright annealed	
257-0001-00	#9F Catalyst		Hydrochloric acid, stannous chloride, palladium chloride	g1 N
257-0011-00	Potassium Cyanide		Reagent #2107	1b M-
257-0012-00	Aluminum Chelate			g1 M+
257-0017-00	Cadmium Anode		Two inch balls	1b K+
257-0019-00	Copper Mix		#328 Shipley, electroless	g1 M-
257-0032-00	Indium Antimomide		Grade 40	gr L
257-0045-00	Tungsten Wire	8.5 flat wire	Fabric .005 mesh weave	ft O
257-0095-00	Tungsten Wire	.001 dia.		ft A+
257-0116-00	Titanium Slug	.250 dia x .500 long	99.99% pure	gr L
258-0345-00	Nickel Foil	.500 x .0025	ASTM F3, bright finish	ft A
258-0373-00	Dura Nickel Strip	.025 x .375	Alloy 301, cold drawn, age hardened	1b N+
258-0395-04	Be Ni Foil	.006 x 3.500	Alloy 400, annealed	1b N+
258-0401-02	Be Ni Foil	.00275 x 2.750	Alloy 400, Hard	1b O-
258-0410-00	Manganin Foil	.001 x 6.000	Alloy 301, cold drawn, age hardened	1b O+
258-0496-00	Copper Silver Foil	.002 x 1.000		ft K+
258-0497-00	Nickel Strip	.010 x 6.000 to 7.000	Dead soft	1b L+
258-0506-00	Nickel Wire	.010 x .125 W	Alloy 200, ASTM B162	1b N
258-0508-00	Phosphor Bronze			
258-0512-00	Nickel Silver		.5% Lithium Stearate	1b K-
258-0522-00	Nickel Alloy	.025 dia.	Alloy 52 (51% nickel & 49% iron)	1b N+
258-0526-00	Lead Sheet	.080 x 24.000 x 102.000	Rolled condition	1b I+
258-0532-00	Nickel & Chrome	3.500 x .010	Alloy X-750, bright annealed	1b O+
258-0534-00	Gold Pl., Sq. Wire	.025 W x .025 thick		

12

COST CODE (CC COLUMN)

CODE	A	B	C	D	E	F	G	H	I	J	K	L	M	N	O
≈ VALUE with +	.75¢	2¢	3.75¢	6¢	10¢	18¢	35¢	60¢	\$1	\$2	\$3.75	\$6	\$10	\$18	\$35+
≈ VALUE no suffix	.5¢	1.5¢	3¢	5¢	8¢	15¢	25¢	50¢	75¢	\$1.50	\$3	\$5	\$8	\$15	\$25
≈ VALUE with -	.2¢	1.25¢	2.5¢	4.25¢	7¢	13¢	22¢	40¢	65¢	\$1.25	\$2.50	\$4.25	\$7	\$13	\$22

NOTE: Costs may vary from order to order due to order quantities, vendor, etc.

MISCELLANEOUS PRECIOUS METALS

PART NUMBER	CC	DESCRIPTION
176-0243-00	ft D	Gold Wire, .001 diameter, 99.99% pure, 2 inches aluminum spool
176-0261-00	ft E+	Gold Wire, .0007 diameter, 99.99% pure, 2 inches aluminum spool
257-0020-00	TO O+	Gold Replenisher, Orotherm HT-T, plating salt
257-0025-00	gr K	Gold Liquid, Englehard
257-0026-00	TO J+	Silver Wire, .06745 diameter, .250 hard, F1000
257-0027-00	TO O+	Gold Flake, Metz #14
257-0030-00	ft J	Platinum Alloy Foil, .021 x .003, 90% platinum and 1% iridium
257-0035-00	ea E	Silver Disk, .350 diameter x .010 grade, 99.99% pure, ASTM B413 annealed
257-0039-00	TO O+	Gold Salts, Lea Ronal Aurall Gold Metal
257-0040-00	TO O+	Gold Salts, Auro-Vel up-24
257-0043-00	TO O+	Gold Salts, Orosene PC
257-0068-00	gr N-	Gold Replenisher, #402 Pur-A-Gold
257-0077-00	gr J+	Gold Resinate, Englehard A-2660
257-0081-00	TO O+	Copper Alloy Wire, .020 diameter with .00125 gold layer
257-0083-00	ea G-	Gold/Tin Preform, 20 mil diameter x 1 mil thick, 80% gold, 20% tin
257-0084-00	ft H+	Gold Wire, .0007 diameter, 99.99% pure
257-0085-00	ft H+	Gold Foil, .010 x .001, 99.99% pure
257-0086-00	ft K	Gold Foil, .025 x .001, 99.99% pure
257-0087-00	ea F+	Gold Preform, .100 square inch x .002, 99.99% pure
257-0088-00	ft G	Gold Wire, .001 diameter, 99.99% pure
257-0089-00	ft H	Gold Foil 99.99% pure, .035 ± .0002 x .001 ± .0002 x 100 feet on 2 inch aluminum spool
257-0091-00	ea G	Gold/Tin Preform, .0015 thick, 80% gold, 20% tin
257-0093-00	ea B-	Gold Wire, .005 diameter, 99.99% pure
257-0096-00	ft E	Gold Wire, .0013 diameter, 99.99% pure on 2 inch aluminum spool
257-0097-00	ft F+	Gold Wire, .002 diameter, 99.99% pure on 2 inch aluminum spool
257-0099-00	ft J	Gold Foil, .005 x .001, 99.99% pure, 50 feet on 2 inch aluminum spool
257-0100-00	TO O+	Gold Replenisher
257-0101-00	ea I+	Gold Preform, .050 diameter x .002 thick
257-0102-00	ft H-	Gold Wire, .005 diameter, 99.99% pure, 100 feet on 4 inch aluminum spool
257-0104-00	TO O+	Gold Salts, Auro-Vel upa-24
257-0106-00	ea F	Gold Preform, .100 square inch x .001 99.99% pure
257-0108-00	TO N-	Silver Replenisher, Sal-A-Salt electroplating process
257-0109-00	ea F	Gold Preform, .020 diameter x .001 thick, 99.99% pure arsenic 1%
257-0110-00	TO O+	Gold Liquid, Aurobond TCL electroplating process
257-0115-00	ea B	Gold Preform, .015 diameter x .001 thick, 99.99% pure, arsenic 1%
257-0117-00	gr M	Palladium Slug
257-0118-00	gr N+	Gold Slug, .250 diameter x .250 long, 99.95% pure

SILICON WAFERS

PART NUMBER	CC	DESCRIPTION
257-0029-00	ea L	P-Type monocrystalline
257-0049-00	ea K	2.000 diameter x .015, 100Ω, Boron Doped
257-0057-00	ea L	2.000 diameter, 10Ω, Boron Doped, P-Type
257-0059-00	ea M-	2.000 diameter, 4Ω, Phosphorus Doped, N-Type
257-0060-00	ea K+	2.000 diameter, 4Ω, Phosphorus Doped, N-Type
257-0060-01		2.000 diameter, 4Ω, Phosphorus Doped, Oxidized
257-0064-00	ea L-	2.000 diameter, .25Ω, Phosphorus Doped
257-0066-00	ea L-	2.000 diameter, 1Ω
257-0080-00	ea K+	2.000 diameter, .01Ω, 100 orientation, 15 mil thick
257-0082-00	ea L-	2.000 diameter, .005Ω
257-0090-00	ea L	2.000 diameter, 50Ω
257-0092-00	ea O+	2.100 long x 1.750 x .040 thick
257-0111-00	ea M-	3.000 diameter, .250Ω, 111 orientation
257-0112-00	ea L	3.000 diameter, 10-20Ω, 111 orientation, Boron Doped, P-Type
257-0113-00	ea L+	3.000 diameter, 38-100Ω, 111 orientation

COST CODE

(CC COLUMN)

CODE	A	B	C	D	E	F	G	H	I	J	K	L	M	N	O
≈ VALUE with +	.75¢	2¢	3.75¢	6¢	10¢	18¢	35¢	60¢	\$1	\$2	\$3.75	\$6	\$10	\$18	\$35+
≈ VALUE no suffix	.5¢	1.5¢	3¢	5¢	8¢	15¢	25¢	50¢	75¢	\$1.50	\$3	\$5	\$8	\$15	\$25
≈ VALUE with -	.2¢	1.25¢	2.5¢	4.25¢	7¢	13¢	22¢	40¢	65¢	\$1.25	\$2.50	\$4.25	\$7	\$13	\$22

NOTE: Costs may vary from order to order due to order quantities, vendor, etc.

12

PANELS , PURCHASED

PART NUMBER	INSTRUMENT USED ON	CC/EA
333-2454-02	4663	N-
333-2510-00	4052	N
333-2532-00	067-0892-00	M-
333-2559-00	832 Opt 2	J+
333-2560-00	832 Opt 2 (Back)	I+
333-2566-00	1980	M-
333-2567-00	1980 (Door)	O+
333-2575-00	8501	K
333-2599-00	SG 505	M-
333-2599-01	SG 505 Opt 1	M-
333-2607-00	690 SR (Left)	I-
333-2608-00	69M 41	L+
333-2609-00	067-0938-00	M+
333-2619-00	A6902	L-
333-2631-00	AA501	K+
333-2631-01	AA501 Opt	L
333-2641-00	DC 503A	J+
333-2642-00	4114 Opt 43	N-
333-2643-00	8301	K
333-2647-00	492P	I+
333-2647-01	492	J+
333-2651-00	834	L
333-2652-00	834	M
333-2652-01	834 Opt 4	M-
333-2653-00	2335	L
333-2654-00	PG 507	M+
333-2655-00	DC509P	K
333-2656-00	492 (Rear)	I+
333-2657-01	4114	L
333-2660-00	8301	J+
333-2661-00	8301	K+
333-2671-00	PS510P	J+
333-2679-00	2215	K-
333-2680-00	2213	K-
333-2683-00	FG507	L
333-2684-00	FG501A	J+

PART NUMBER	INSTRUMENT USED ON	CC/EA
333-2688-01	4112	N-
333-2698-00	DA S9109	N
333-2702-00	TR503 (Right)	L
333-2703-00	TR503 (Left)	L
333-2704-01	492P 1, 2 & 3	N+
333-2704-02	492P Opt 1 & 2	O+
333-2704-03	492P Opt 2 & 3	O+
333-2709-00	LID 2336	M
333-2710-00	LID 2337	M
333-2711-00	R492	M
333-2725-00	4114 Opt 42	N+
333-2731-03	496 Opt 2 & 3	N-
333-2732-03	496 P Opt 2 & 3	O+
333-2736-00	DM5 10P	K-
333-2737-00	FG510P	K
333-2744-00	2336	L
333-2746-00	DC510P	L
333-2749-00	2337	L+
333-2750-00	SA501	L+
333-2766-01	4112 Opt 42	L-
333-2767-01	4112	M+
333-2775-01	4112 Opt 13 & 14	M+
333-2780-00	A6901	K+
333-2781-00	A6901 (Rear)	K+
333-2787-00	OF150	M
333-2791-00	OF150 (Rear)	J+
333-2794-00	528A (Right)	I-
333-2795-00	528A (Left)	H+
333-2799-00	496 (Rear)	J
333-2801-00	690 SR	N-
333-2825-00	69M00	K
333-2870-00	015-0412-00	L+
333-2882-00	1424 (Right)	J-
333-2883-00	1424 (Left)	J-
333-2890-00	8560	J+
333-2893-00	8540	J+
333-2894-00	8540	J+

COST CODE (CC COLUMN)

CODE	A	B	C	D	E	F	G	H	I	J	K	L	M	N	O
≈ VALUE with +	.75¢	2¢	3.75¢	6¢	10¢	18¢	35¢	60¢	\$1	\$2	\$3.75	\$6	\$10	\$18	\$35+
≈ VALUE no suffix	.5¢	1.5¢	3¢	5¢	8¢	15¢	25¢	50¢	75¢	\$1.50	\$3	\$5	\$8	\$15	\$25
≈ VALUE with -	.2¢	1.25¢	2.5¢	4.25¢	7¢	13¢	22¢	40¢	65¢	\$1.25	\$2.50	\$4.25	\$7	\$13	\$22

NOTE: Costs may vary from order to order due to order quantities, vendor, etc.

SOLDER AND FLUX

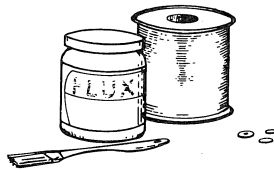

TIN/LEAD*	SIZE	SPOOLS	OTHER	PART NUMBER	CC	
50 Sn/40 Pb/10 Bi	.032 dia.	5 pound	Rosin core	251-0785-00	1b M+	
50 Sn/40 Pb/10 Bi	.050 dia.		Rosin core	251-0786-00	1b N-	
50 Sn/50 Pb	.125 dia.		Rosin core	251-0511-00	1b L	
50 Sn/50 Pb	.032 dia.		Rosin core	251-0683-00	1b L+	
50 Sn/50 In	.060 OD x .025 ID x .020 thick		Preform	251-0821-00	ea A	
50 Sn/50 In	.025 dia.	Cast bar Small coil 21 gauge 1 pound 5 pound	Preform	251-0915-00	ea A-	
59 Sn/37 Pb/4 Ag			251-0509-00	1b O+		
60 Sn/37 Pb/3 Ag	21 gauge		Rosin core	006-0664-00	ea L	
60 Sn/37 Pb/3 Ag	21 gauge		Rosin core	251-0514-00	1b N	
60 Sn/37 Pb/3 Ag	21 gauge		Rosin core	251-0515-00	1b O-	
60 Sn/40 Pb	.005 thick x .375 x .625		Preform	251-0988-01	ea B-	
60 Sn/40 Pb	.312 OD x .190 x .020 thick		Preform	251-0682-00	ea B	
60 Sn/40 Pb	.045 ID x .075 OD x .015 thick		Preform	251-3014-00	ea C+	
61.5 Ag/24 Cu/14.5 In	.300 sq. x .002 thick		Preform	251-0822-00	ea C-	
61.5 Ag/24 Cu/14.5 In	.500 OD, .190 ID x .005 thick		Preform	251-0850-00	ea F-	
61.5 Ag/24 Cu/14.5 In	.250 dia x .003 thick		Preform	251-0900-00	ea C-	
62 Sn/36 Pb/2% Ag			Small coil 5 pound 5 pound		251-0933-00	gr H
63 Sn/37 Pb	18 gauge			Rosin core	006-0663-00	ea J+
63 Sn/37 Pb	16 gauge	Rosin core		251-0512-00	1b L+	
63 Sn/37 Pb	18 gauge	Rosin core		251-0513-00	1b M	
63 Sn/37 Pb	.125 dia, .500 1b roll			251-0653-00	1b L+	
63 Sn/37 Pb	.375 x 15.000	1.5 pound bar	Rosin core	251-0545-00	1b L+	
63 Sn/37 Pb	.125 dia	21 pound ingots	Rosin core	251-0545-01	1b L+	
63 Sn/37 Pb	.015 dia	1 pound	Rosin core	251-0738-00	1b M+	
63 Sn/37 Pb	.055 OD x .025 ID x .110 thick	1 pound	Preform	251-0778-00	ea B-	
63 Sn/37 Pb	.205 OD x .157 ID x .020 thick		Washer	251-0787-00	ea C-	
63 Sn/37 Pb	.032 dia.	5 pound	Rosin core	251-0804-01	1b L+	
63 Sn/37 Pb	.043 OD x .027 ID x .008 thick	1 pound	Preform	251-0806-00	ea A	
63 Sn/37 Pb	.032 dia.	1 pound	Rosin core	251-0807-01	1b M	
63 Sn/37 Pb	.346 OD x .285 ID		Rosin core	251-3010-00	ea B	
88 Au/12 Ge	.021 dia. x .001		Preform	251-0691-00	ea A	
89 Sn/7.5 Sb/3.5 Cu	.188 dia.	50 pound		251-0752-00	1b M+	
97.5 Pb/2.5 Ag	.032 gauge		Rosin core	251-0551-00	1b M+	
97.5 Pb/2.5 Sn	.025 dia. x .0015 thick		Preform	251-0724-00	ea A-	
Sn/Al	.312 dia.	12 sticks per 1b		251-0648-00	1b L	
	.185 sq. x .002 thick		Preform	251-3008-00	ea C	

SOLDER PASTE

256-0664-00 256-0665-00
 CC: I/gr CC: F/gr
 DP9429 Multicore XM-27330

* Tin - Sn
 Lead - Pb
 Silver - Ag
 Copper - Cu
 Indium - In
 Bismuth - Bi
 Antimony - Sb
 Germanium - Ge

SOLDERWICK

006-1356-00
 CC: J/ea
 5 foot lengths

SOLDER INFORMATION

"Solder" refers to soft solder composed primarily of tin and lead. Soft solder is used for the purpose of joining together two or more metals at temperatures below their melting points. For general assembly line hand soldering, a eutectic, rosin core solder (63% tin, 37% lead) is used because it has one sharp melting point of 361°. Other alloys stay plastic for a short time (plastic range) and joints will be damaged if parts are moved during this time. For flow soldering, 63/37 bar solder is used. Solder used in production areas meets the requirements of Federal Specification QQ-S-571.

For further information, refer to "Assembly Workshop Spec. Manual" or call Barbara Buck on extension 1245.

FLUX

PART NUMBER	DESCRIPTION	CC
252-0045-00	Formula 1544	pt K-
256-0533-00	#2213 Saf-T-Flux	pt K

DESOLDERING TOOLS - STATIC CHARGE

TOOL	CHARGE LEVEL RETAINED ON TOOL	
	Immediate charge	Charge after time
Silverstat Soldapullt	0V	0V After five minutes
Deluxe Soldapullt	3kV	300-400V After five minutes
Standard Soldapullt	20kV	10kV After five minutes
Bulb Solder Sucker	10kV	4kV After five minutes
Solder-Wick	*2kV	0V After one minute

*Charge was retained due to solder-wick's plastic reel

Some circuit board components are sensitive to static charge. Also, some desoldering tools create a static charge. In order to identify and preclude potential problems, we have tested the various desoldering tools available for use at Tek.

A circuit board was used, with components removed, to determine static levels. Each device was tested ten times. The desoldering tools were checked for immediate charge retention and for the charge held after five minutes.

Each of the tools except the Silverstat Soldapullt, left a static charge on the circuit board and retained a charge (see chart). The Silverstat Soldapullt, a model with a metallized surface, left no charge and also retained no charge. Therefore, it is the preferred tool. It has been assigned part number 003-0795-00.

For more information on these desoldering tools, contact Herb Zajac, ext. 7887.

SOLDER

SOLDERS USED AT TEK

NOMINAL COMPOSITION % (SEE TEK PART NUMBERS PAGE 12-8)	MELTING RANGES °C/°F (APPROX. ONLY)		DENSITY gms/cm ³
	Solidus*	Liquidus**	
50 Sn/40 Pb/10 Bi	120/248	167/334	8.77
50 Sn/50 In	118/244	125/257	7.30
50 Sn/50 Pb	183/361	212/413	8.85
59 Sn/37 Pb/4 Ag	190/374	262/503	8.60
60 Sn/37 Pb 3 Ag	183/361	252/485	8.50
60 Sn/40 Pb	183/361	188/374	8.65
61.5 Ag/24 Cu/14.5 In	630/1166	705/1301	9.48
63 Sn/37 Pb	183/361	183/361	8.42
88 Au/12 Ge	356/673	356/673	14.67
89 Sn/7.5 Sb/3.6 Cu	241/466	354/669	7.39
95 Pb/5 Sn	310/590	314/598	11.30
95 Sn/5 Sb	233/452	240/464	7.25
97.5 Pb/1.5 Ag/1 Sn	309/588	309/588	11.28
97.5 Pb/2.5 Ag	303/579	303/579	11.35
97.5 Pb/2.5 Sn	32/90	3.6/600	11.33

* TEMPERATURE AT WHICH SOLDER BEGINS TO MELT.

** TEMPERATURE AT WHICH THE SOLDER IS COMPLETELY MOLTEN.

SUGGESTED SOLDERS FOR ALUMIUM

COMPOSITION %	MELTING RANGES °C/°F (APPROX. ONLY)		DENSITY gms/cm ³	WETTING ABILITY ON ALUMINUM	RELATIVE CORROSION RESISTANCE
	SOLIDUS	LIQUIDUS			
60 Sn/40 Zn	199/390	341/645	7.20	Good	Good
60 Zn/40 Cd	265/509	335/635	7.75	Very Good	Fair
70 Zn/30 Sn	199/390	376/708	7.20	Good	Good
70 Sn/30 Zn	199/390	311/592	7.20	Fair	Fair
80.1 Pb/18 Sn/1.9 Ag†	178/350	270/518	10.10	Very Good	Good
90 Zn/10 Cd	265/509	399/750	7.20	Good	Fair
91 Sn/9 Zn	199/390	199/390	7.20	Fair	Fair
95 Sn/5 Al	399/720	399/720	6.64	Good	Very Good
100 Zn (high purity)	419/787	419/787	7.20	Good	Very Good

† ALU-SOL 45D MULTICORE SOLDER. SUGGESTED SOLDERING TEMPERATURE IS 300 - 350°C.

SOLDERABILITY CHART & FLUX SELECTOR GUIDE

METALS	SOLDERABILITY	ROSIN FLUXES			ORGANIC FLUXES WATER SOLUBLE	INORGANIC FLUXES WATER SOLUBLE	SPECIAL FLUX AND/OR SOLDER
		NON-ACTIVATED	MILDLY ACTIVATED	ACTIVATED			
Platinum Gold Copper Silver Cadmium Plate Tin (Hot Dipped) Tin Plate Solder Plate	Easy to Solder	✓	✓	✓	✓	Not recommended for electrical soldering	
Lead Nickel Plate Brass Bronze Rhodium Beryllium Copper	Less Easy to Solder		Not Suitable		✓	✓	
Galvanized Iron Tin-Nickel Nickel-Iron Mild Steel	Difficult to Solder		Not Suitable		✓	✓	
Chromium Nickel-Chromium Nickel-Copper Stainless Steel	Very Difficult to Solder		Not Suitable			✓	
Aluminum Aluminum-Bronze	Most Difficult to Solder		Not Suitable		Not Suitable		✓
Beryllium Titanium	Not Solderable						

12

CROSS REFERENCE INDEX

METALS AND SOLDER

PART NUMBER	DESCRIPTION	SIZE	PAGE NO.	STATUS§§	PART NUMBER	DESCRIPTION	SIZE	PAGE NO.	STATUS§§
006-0663-00	Solder	18 Gauge	12-8	CR	251-0994-00	Ni-Chr Iron Wire	.025 x 8.000	12-3	CR
006-0664-00	Solder	21 Gauge	12-8	CR	251-0996-00	Iron-Nickel Bar	1.000 Dia	12-5	CS
006-1356-00	Solderwick		12-8	CR	251-3008-00	Solder	.185 Sq Preform	12-8	CR
176-0243-00	Gold Wire	.001 dia	12-6	CR	251-3010-00	Solder	.246 OD x .285 ID	12-8	CR
176-0261-00	Gold Wire	.007 dia	12-6	CR	251-3014-00	Solder	.045 ID Preform	12-8	CR
251-0419-00	Iron-Chr-Al Strip	.020 x 1.500	12-5	CS	251-3023-00	Tung. Carbide Wire	.008 Dia	12-5	CR
251-0419-01	Iron-Chr-Al Strip	.0186 x 1.750	12-5	CR	251-3030-00	Zinc Alloy Ingot	1.375 x 2.688	12-5	CR
251-0444-00	Be-Ni Foil	.003 x 3.000		LS	251-3061-00	Nickel Chrome Strip	.010 x 3.500	12-5	PP
251-0444-02	Be-Ni Foil	.003 x .655		NP	252-0010-00	Flux Thinner			DL
251-0444-04	Be-Ni Foil	.003 x .797		NP	252-0045-00	Flux		12-8	CR
251-0444-05	Be-Ni Foil	.003 x .312		DL	252-0060-00	Flux			DL
251-0444-06	Be-Ni Foil	.003 x .655		NP	252-0070-00	Flux			DL
251-0444-07	Be-Ni-Foil	.003 x 2.000		DL	252-0093-00	Flux			DL
251-0508-00	Tin Bar		12-5	CR	256-0533-00	Flux		12-8	CR
251-0509-00	Solder	Cast Bar	12-8	CR	256-0664-00	Solder Paste		12-8	CR
251-0511-00	Solder	.125 Dia	12-8	CR	256-0665-00	Solder Paste		12-8	CR
251-0512-00	Solder	16 Gauge	12-8	CR	257-0001-00	Catalyst		12-5	CR
251-0513-00	Solder	18 Gauge	12-8	CR	257-0011-00	Potassium Cyanide		12-5	CR
251-0514-00	Solder	21 Gauge	12-8	CR	257-0012-00	Aluminum Chelate		12-5	CR
251-0515-00	Solder	21 Gauge	12-8	CR	257-0017-00	Cadmium Anode		12-5	CR
251-0534-00	Solder	.062 Dia		DL	257-0019-00	Copper Mix		12-5	CR
251-0545-00	Solder	.375 x 15.000	12-8	CR	257-0020-00	Gold Replenisher		12-6	CR
251-0545-01	Solder	.125 Dia	12-8	CR	257-0025-00	Gold Liquid		12-6	CR
251-0551-00	Solder	.032 Gauge	12-8	CR	257-0026-00	Silver Wire	.06745 Dia	12-6	CR
251-0552-00	Solder	.125 Dia		DL	257-0027-00	Gold Flake		12-6	CR
251-0555-00	Inconel Ni Alloy	.020 x .125	12-5	DL	257-0029-00	Silicon Wafer		12-6	CR
251-0560-00	Monel Mesh	#10-210		CR	257-0030-00	Platinum Alloy Foil	.021 x .003	12-6	CR
251-0561-00	Monel Mesh	#10-0006		DL	257-0032-00	Indium Antimonide		12-5	CR
251-0570-00	Steel Wire	.0006 x .187	12-5	CR	257-0035-00	Silver Disk	.350 Dia	12-6	CS
251-0648-00	Solder	.312 Dia	12-8	CR	257-0039-00	Gold Salts		12-6	CR
251-0651-00	Solder	.030 Dia		DL	257-0040-00	Gold Salts		12-6	CR
251-0653-00	Solder	.125 Dia	12-8	CR	257-0043-00	Gold Salts		12-6	CR
251-0680-00	Iron-Nickel Tube	.088 x .0255	12-4	CR	257-0045-00	Tungsten Wire	8.500 Flat	12-5	CR
251-0682-00	Solder	.190 ID Preform	12-8	CS	257-0049-00	Silicon Wafer	2.000 Dia x .015	12-6	CR
251-0683-00	Solder	.032 Dia	12-8	CR	257-0057-00	Silicon Wafer	2.000 Dia	12-6	CR
251-0691-00	Solder	.021 Dia Preform	12-8	CR	257-0059-00	Silicon Wafer	2.000 Dia	12-6	CR
251-0702-00	Monel Strip	.020 x 2.625	12-5	CR	257-0060-00	Silicon Wafer	2.000 Dia	12-6	CR
251-0724-00	Solder	.025 Dia Preform	12-8	CS	257-0060-01	Silicon Wafer	2.000 Dia	12-6	PP
251-0736-00	Monel	.003 x 6.000	12-5	CS	257-0064-00	Silicon Wafer	2.000 Dia	12-6	CR
251-0737-00	Monel	.005 x 6.000	12-5	CS	257-0066-00	Silicon Wafer	2.000 Dia	12-6	CR
251-0738-00	Solder	.015 Dia	12-8	CR	257-0068-00	Gold Replenisher		12-6	CR
251-0740-00	Iron Ingot	.020 x .250	12-5	CS	257-0077-00	Gold Resinate		12-6	CR
251-0745-00	Tin-Lead Foil	.0004 x .250	12-5	CR	257-0080-00	Silicon Wafer	2.000 Dia	12-6	CR
251-0752-00	Solder	.188 Dia	12-8	CR	257-0081-00	Copper Alloy Wire	.020 Dia	12-6	CR
251-0760-00	Tin-Lead Foil	.0004 x .625	12-5	CR	257-0082-00	Silicon Wafer	2.000 Dia	12-6	CR
251-0778-00	Solder	.025 ID Preform	12-8	CS	257-0083-00	Gold/Tin Preform	20 Mil Dia	12-6	CR
251-0785-00	Solder	.032 Dia	12-8	CR	257-0084-00	Gold Wire	.0007 Dia	12-6	CR
251-0786-00	Solder	.050 Dia	12-8	CR	257-0085-00	Gold Foil	.010 x .001	12-6	CR
251-0787-00	Solder	.157 ID Preform	12-8	CR	257-0086-00	Gold Foil	.025 x .001	12-6	CR
251-0804-01	Solder	.032 Dia	12-8	CR	257-0087-00	Gold Preform	.100 Sq x .002	12-6	CR
251-0806-00	Solder	.027 ID Preform	12-8	CR	257-0088-00	Gold Wire	.001 Dia	12-6	CR
251-0807-00	Solder	.032 Dia		NP	257-0089-00	Gold Foil	.035 x .001	12-6	CR
251-0807-01	Solder	.032 Dia	12-8	CR	257-0090-00	Silicon Wafer	2.000 Dia	12-6	CR
251-0819-00	Nickel Foil	.002 x .050	12-5	CS	257-0091-00	Gold/Tin Preform	.0015 Thick	12-6	CR
251-0821-00	Solder	.025 ID Preform	12-8	CR	257-0092-00	Silicon Wafer	2.100 Ig x 1.750	12-6	CR
251-0822-00	Solder	.250 Sq Preform	12-8	CR	257-0093-00	Gold Wire	.005 Dia	12-6	CR
251-0833-00	Nickel Foil	.005 x .125	12-5	CR	257-0095-00	Tungsten Wire	.001 Dia	12-6	CR
251-0838-00	Solder	.032 Dia		DL	257-0096-00	Gold Wire	.0013 Dia	12-6	CR
251-0840-00	Nickel Foil	.005 x .100	12-5	CR	257-0097-00	Gold Wire	.002 Dia	12-6	PP
251-0841-00	Ni-Chr Iron Wire	.025 x .125	12-3	CR	257-0099-00	Gold Foil	.005 x .001	12-6	CR
251-0846-00	Nickel Foil	.005 x 2.000	12-5	CR	257-0100-00	Gold Replenisher		12-6	CR
251-0850-00	Solder	.190 ID Preform	12-8	CR	257-0101-00	Gold Preform	.050 Dia x .002	12-6	CR
251-0854-00	Tin-Lead Foil	.00025 x .375	12-5	CR	257-0102-00	Gold Wire	.005 Dia	12-6	CR
251-0872-00	Nickel	.080 x .045	12-5	CR	257-0104-00	Gold Salts		12-6	CR
251-0898-00	Nickel Foil	.005 x 2.200	12-5	CR	257-0106-00	Gold Preform	.100 Sq x .001	12-6	CR
251-0900-00	Solder	.250 Dia Preform	12-8	CR	257-0108-00	Silver Replenisher		12-6	PP
251-0902-00	Nickel Foil	.002 x .250	12-5	CR	257-0109-00	Gold Preform	.020 Dia x .001	12-6	CR
251-0915-00	Solder	.025 Dia Preform	12-8	CR	257-0110-00	Gold Liquid		12-6	PP
251-0933-00	Solder		12-8	CR	257-0111-00	Silicon Wafer	3.000 Dia	12-6	MP
251-0963-00	Solder	.060 ID Preform	12-8	CR	257-0112-00	Silicon Wafer	3.000 Dia	12-6	CR
251-0964-00	Nickel Bar	.531 Dia		DL	257-0113-00	Silicon Wafer	3.000 Dia	12-6	CR
251-0974-00	Iron Strip	.014 x 8.000		DL	257-0115-00	Gold Preform	.015 Dia x .001	12-6	CR
251-0988-00	Solder	.002 x .370 x .632		NP	257-0116-00	Titanium Slug	.250 Dia x .500	12-5	CR
251-0988-01	Solder	.375 x .625 Preform	12-8	CR	257-0117-00	Palladium Slug		12-6	CR
251-0990-00	Iron-Nickel Strip	.015 x 4.500	12-5	CR	257-0118-00	Gold Slug	.250 Dia x .250	12-6	CR
					258-0308-00	Be-Ni Foil	.005 x 2.750		LR
					258-0319-00	Ni-Ag Strip	.0359 x 6.000	12-2	CS

12

CROSS REFERENCE INDEX

METALS AND SOLDER

PART NUMBER	DESCRIPTION	SIZE	PAGE NO.	STATUS ^{§§}
258-0332-00	Iron-Nickel Foil	.003 x 6.500	12-4	CR
258-0345-00	Nickel Foil	.500 x .0025	12-5	CR
258-0354-00	Ni-Ag Sheet	.049 x 12 x 96	12-2	CS
258-0355-00	Ni-Ag Sheet	.025 x 24 x 96	12-2	CS
258-0355-01	Ni-Ag Wire	.025 x .188	12-2	CS
258-0357-00	Ni-Ag Wire	.015 x .188	12-2	CR
258-0364-00	Iron-Nickel Foil	.003 x .062	12-4	CR
258-0370-00	Iron-Nickel Strip	.010 x 8.000	12-4	CR
258-0372-00	Ni-AL Wire	.008 x .200		DL
258-0373-00	Dura Nickel Strip	.025 x .375	12-5	OT
258-0392-00	Be-Ni Wire	.010 x .500		DL
258-0392-01	Be-Ni Wire	.010 x 2.750		LR
258-0395-01	Be-Ni Wire	.006 x .250		DL
258-0395-03	Be-Ni Wire	.006 x 1.093		LS
258-0395-04	Be-Ni Foil	.006 x 3.500	12-5	CR
258-0397-00	Be-Ni Foil	.0035 x 2.750		LR
258-0401-00	Be-Ni Foil	.00275 x .530		DL
258-0401-02	Be-Ni Foil	.00275 x 2.750	12-5	LR
258-0410-00	Manganin Foil	.001 x 6.000	12-5	CR
258-0410-01	Manganin Foil	.010 x 6.187		DL
258-0419-00	Be-Ni Wire	.006 x .312		NP
258-0422-00	Ni-Chr Iron Wire	.025 x .125	12-3	CR
258-0441-00	Copper-Nickel Strip	.010 x 6.000		LR
258-0446-00	Iron-Nickel Foil	.005 x 8.000	12-4	CR
258-0494-00	Be-Ni Foil	.002 x 2.250		LS
258-0496-00	Copper-Silver Foil	.002 x 1.000	12-5	CR
258-0497-00	Nickel Strip	.010 x 6.000	12-5	CR
258-0501-00	Copper Tinsel			DL
258-0506-00	Nickel Wire	.010 x .125	12-5	CR
258-0508-00	Phosphor Bronze		12-5	CR
258-0512-00	Nickel Silver		12-5	CR
258-0522-00	Nickel Alloy	.025 Dia	12-5	CR
258-0526-00	Lead Sheet	.080 x 24.000	12-5	PP
258-0532-00	Nickel & Chrome	3.500 x .010	12-5	PP
258-0534-00	Gold Pl, Sq Wire	.025 W x .025 Thk	12-5	MP
333-2454-02	Front Panel		12-7	CR
333-2510-00	Front Panel		12-7	CR
333-2532-00	Front Panel		12-7	CR
333-2559-00	Front Panel		12-7	CR
333-2560-00	Front Panel		12-7	CR
333-2566-00	Front Panel		12-7	CR
333-2567-00	Front Panel		12-7	CR
333-2575-00	Front Panel		12-7	CR
333-2599-00	Front Panel		12-7	CR
333-2599-01	Front Panel		12-7	CR
333-2607-00	Front Panel		12-7	CR
333-2608-00	Front Panel		12-7	CR
333-2609-00	Front Panel		12-7	CR
333-2619-00	Front Panel		12-7	CR
333-2631-00	Front Panel		12-7	CR
333-2631-01	Front Panel		12-7	CR
333-2641-00	Front Panel		12-7	CR
333-2642-00	Front Panel		12-7	CR
333-2643-00	Front Panel		12-7	CR
333-2647-00	Front Panel		12-7	CR
333-2647-01	Front Panel		12-7	CR
333-2651-00	Front Panel		12-7	CR
333-2652-00	Front Panel		12-7	CR
333-2652-01	Front Panel		12-7	CR
333-2653-00	Front Panel		12-7	CR
333-2654-00	Front Panel		12-7	CR
333-2655-00	Front Panel		12-7	CR
333-2656-00	Front Panel		12-7	CR
333-2657-01	Front Panel		12-7	CR
333-2660-00	Front Panel		12-7	CR
333-2661-00	Front Panel		12-7	CR
333-2671-00	Front Panel		12-7	CR
333-2679-00	Front Panel		12-7	CR
333-2680-00	Front Panel		12-7	CR
333-2683-00	Front Panel		12-7	CR
333-2684-00	Front Panel		12-7	CR

PART NUMBER	DESCRIPTION	SIZE	PAGE NO.	STATUS ^{§§}
333-2688-01	Front Panel		12-7	CR
333-2698-00	Front Panel		12-7	CR
333-2702-00	Front Panel		12-7	CR
333-2703-00	Front Panel		12-7	CR
333-2704-01	Front Panel		12-7	CR
333-2704-02	Front Panel		12-7	CR
333-2704-03	Front Panel		12-7	CR
333-2709-00	Front Panel		12-7	CR
333-2710-00	Front Panel		12-7	CR
333-2711-00	Front Panel		12-7	CR
333-2725-00	Front Panel		12-7	CR
333-2731-03	Front Panel		12-7	CR
333-2732-03	Front Panel		12-7	CR
333-2736-00	Front Panel		12-7	CR
333-2737-00	Front Panel		12-7	CR
333-2744-00	Front Panel		12-7	CR
333-2746-00	Front Panel		12-7	CR
333-2749-00	Front Panel		12-7	CR
333-2750-00	Front Panel		12-7	CR
333-2766-01	Front Panel		12-7	CR
333-2767-01	Front Panel		12-7	CR
333-2775-01	Front Panel		12-7	CR
333-2780-00	Front Panel		12-7	CR
333-2781-00	Front Panel		12-7	CR
333-2787-00	Front Panel		12-7	CR
333-2791-00	Front Panel		12-7	CR
333-2794-00	Front Panel		12-7	CR
333-2795-00	Front Panel		12-7	CR
333-2799-00	Front Panel		12-7	CR
333-2801-00	Front Panel		12-7	CR
333-2825-00	Front Panel		12-7	CR
333-2870-00	Front Panel		12-7	CR
333-2882-00	Front Panel		12-7	CR
333-2883-00	Front Panel		12-7	CR
333-2890-00	Front Panel		12-7	CR
333-2893-00	Front Panel		12-7	CR
333-2894-00	Front Panel		12-7	CR

§§ STATUS CODES

CR	Current Production
EN	Engineering
PP	Pre-Production
CS	Customer Service
NP	Non-Production
DL	Deleted
OB	Obsolete Instrument
CM	Custom Mod Instrument
DS	Digital Systems
OT	Obsolescent Instrument
MP	Modified Part
LR	Last Supply Current
LS	Last Supply Customer Service
VN	Vendor
TC	Tequipment Current Production
IN	International
SC	Sony/Tek Current Production

THE STATUS IN THIS CATALOG WAS CORRECT AT THE TIME IT WAS PUBLISHED, BUT IT IS SUBJECT TO CHANGE.

§ TO USE A PART WITH THIS STATUS ON A NEW INSTRUMENT REQUIRES THAT A NEW PURCHASED PART INITIATION FORM (PPIF) BE INITIATED.

(A GLOSSARY OF TERMS FOR THESE STATUS CODES CAN BE FOUND ON PAGE 0-10).

BRASS, CU BE, PH BRZ, COPPER AND MISC ALLOYS

TOLERANCES

ASTM B248

TABLE 1 THICKNESS TOLERANCES
(Applicable to Specifications B 36, B 121, B 152, and B 465)

Thickness Tolerances, plus and minus, in.

Thickness, in.	Strip				Sheet			
	8 in. and under in width	Over 8 to 12 in. incl., in width	Over 12 to 14 in. incl., in width	Over 14 to 20 in. incl., in width	Over 20 to 28 in. incl. in width	Over 28 to 36 in. incl., in width	Over 36 to 48 in. incl., in width	Over 48 to 60 in. incl. in width
.004 and under	.0003	.0006	.0006					
Over .004 to .006 incl.	.0004	.0008	.0008	.0013				
Over .006 to .009 incl.	.0006	.0010	.0010	.0015				
Over .009 to .013 incl.	.0008	.0013	.0013	.0018	.0025	.003	.0035	.004
Over .013 to .017 incl.	.0010	.0015	.0015	.002	.0025	.003	.0035	.0045
Over .017 to .021 incl.	.0013	.0018	.0018	.002	.003	.0035	.004	.005
Over .021 to .026 incl.	.0015	.002	.002	.0025	.003	.0035	.004	.005
Over .026 to .037 incl.	.002	.002	.002	.0025	.0035	.004	.005	.006
Over .037 to .050 incl.	.002	.0025	.0025	.003	.004	.005	.006	.007
Over .050 to .073 incl.	.0025	.003	.003	.0035	.005	.006	.007	.008
Over .073 to .130 incl.	.003	.0035	.0035	.004	.006	.007	.008	.010
Over .130 to .188 incl.	.0035	.004	.004	.0045	.007	.008	.010	.012
	Rolled Bar				Plate			
Over .188 to .205 incl.	.0035	.004	.004	.0045	.007	.008	.010	.012
Over .205 to .300 incl.	.004	.0045	.0045	.005	.009	.010	.012	.014
Over .300 to .500 incl.	.0045	.005	.005	.006	.012	.013	.015	.018
Over .500 to .750 incl.	.0055	.007	.007	.009	.015	.017	.019	.023
Over .750 to 1.00 incl.	.007	.009	.009	.011	.018	.021	.024	.029
Over 1.00 to 1.50 incl.	.022	.022	.022	.022	.022	.025	.029	.036
Over 1.50 to 2.00 incl.	.026	.026	.026	.026	.026	.030	.036	.044

TABLE 2 THICKNESS TOLERANCES
(Applicable to Specifications B 97, B 103, B 122, B 169, B 194, B 422, B 534)

Thickness Tolerances, plus and minus, in.

Thickness, in.	Strip				Sheet			
	8 in. and under in width	Over 8 to 12 in. incl., in width	Over 12 to 14 in. incl. in width	Over 14 to 20 in. incl. in width	Over 20 to 28 in. incl. in width	Over 28 to 36 in. incl. in width	Over 36 to 48 in. incl. in width	Over 48 to 60 in. incl. in width
.004 and under	.0004	.0008	.0008					
Over .004 to .006 incl.	.0006	.0010	.0010	.0015				
Over .006 to .009 incl.	.0008	.0013	.0013	.002				
Over .009 to .013 incl.	.0010	.0015	.0015	.0025				
Over .013 to .017 incl.	.0013	.002	.002	.0025				
Over .017 to .021 incl.	.0015	.0025	.0025	.003				
Over .021 to .026 incl.	.002	.0025	.0025	.003	.004	.005	.006	.007
Over .026 to .037 incl.	.0025	.003	.003	.0035	.005	.006	.007	.008
Over .037 to .050 incl.	.003	.0035	.0035	.004	.005	.006	.008	.010
Over .050 to .073 incl.	.0035	.004	.004	.0045	.007	.008	.010	.012
Over .073 to .130 incl.	.004	.0045	.0045	.005	.008	.010	.012	.014
Over .130 to .188 incl.	.0045	.005	.005	.006	.010	.012	.014	.016
	Rolled Bar				Plate			
Over .188 to .205 incl.	.0045	.005	.005	.006	.010	.012	.014	.016
Over .205 to .300 incl.	.005	.006	.006	.007	.012	.014	.016	.018
Over .300 to .500 incl.	.006	.007	.007	.008	.015	.017	.019	.023
Over .500 to .750 incl.	.008	.010	.010	.012	.019	.021	.024	.029
Over .750 to 1.00 incl.	.010	.012	.012	.015	.023	.026	.030	.037
Over 1.00 to 1.50 incl.	.028	.028	.028	.028	.028	.032	.037	.045
Over 1.50 to 2.00 incl.	.033	.033	.033	.033	.033	.038	.045	.055

TABLE 3 SPECIAL THICKNESS TOLERANCES

Thickness, in. (mm)	Tolerances Applicable to Alloy 725, Specification B122 Tolerances, plus and minus, in (mm) for Strip 8 in and Under in Width	Tolerances Applicable to Specifications B194 and B534 Tolerances, plus and minus, in (mm) for Strip 4 in and Under in Width
0.004 (0.102) and under	0.0002 (0.005)	0.0002 (0.005)
Over 0.004 to 0.006 (0.102 to 0.152), incl	0.0003 (0.008)	0.0003 (0.008)
Over 0.006 to 0.009 (0.152 to 0.229), incl	0.0004 (0.010)	0.0005 (0.013)
Over 0.009 to 0.013 (0.229 to 0.330), incl	0.0005 (0.013)	0.0006 (0.015)
Over 0.013 to 0.017 (0.330 to 0.432), incl	0.0007 (0.018)	0.0007 (0.018)
Over 0.017 to 0.021 (0.432 to 0.533), incl	0.0008 (0.020)	0.0008 (0.020)
Over 0.021 to 0.026 (0.533 to 0.660), incl	0.0010 (0.025)	0.0010 (0.025)
Over 0.026 to 0.032 (0.660 to 0.813), incl	0.0013 (0.033)	0.0010 (0.025)
Over 0.032 to 0.050 (0.813 to 1.27), incl	0.0015 (0.038)	- - -

12

BRASS, CU BE, PH BRZ, COPPER AND MISC ALLOYS

TOLERANCES

ASTM B248

TABLE 4 WIDTH TOLERANCES FOR SLIT METAL AND SLIT METAL WITH ROLLED EDGES
(Applicable to all Specifications Listed Below)

WIDTH, IN.	WIDTH TOLERANCES, PLUS AND MINUS			
	FOR THICKNESSES .004 to .032 IN. INCL.	FOR THICKNESSES .032 to .125 IN. INCL.	FOR THICKNESSES .125 to .188 IN. INCL.	FOR THICKNESSES .188 to .500 IN. INCL.
2 and under	.005	.010	.012	.015
Over 2 to 8 incl.	.008	.013	.015	.015
Over 8 to 24 incl.	.015	.015	.015	.031
Over 24 to 40 incl.	.031	.031	.031	.046

TABLE 5 WIDTH TOLERANCES FOR SQUARE-SHEARED METAL (Applicable to all Specifications Listed Below)

WIDTH, IN.	WIDTH TOLERANCES, PLUS AND MINUS		
	FOR THICKNESSES .062 AND UNDER	FOR THICKNESSES .062 to .125 IN. INCL.	FOR THICKNESSES OVER .125 IN.
20 and under	.031	.046	.062
Over 20 to 36 incl.	.046	.046	.062
Over 36 to 120 incl.	.062	.062	.062

TABLE 6 WIDTH TOLERANCES FOR SAWED METAL (Applicable to all Specifications Listed Below)

WIDTH, IN.	WIDTH TOLERANCES, PLUS AND MINUS		
	FOR LENGTHS UP TO 10 FT. INCL.		FOR LENGTH OVER 10 FT.
	FOR THICKNESSES UP TO 1.500 IN. INCL.	FOR THICKNESSES OVER 1.500 IN.	ALL THICKNESSES
Up to 12 incl.	.031	.062	.062
Over 12 to 120 incl.	.062	.062	.062

TABLE 7 LENGTH TOLERANCES FOR STRAIGHT LENGTHS (Applicable to all Specifications Listed Below)

LENGTH, FT (m)	LENGTH TOLERANCES	
	IN	mm
Specific lengths, mill lengths, multiple lengths, and specific lengths with ends		
10 (3.05) and under	1/4	6.4
Over 10 (3.05) to 20 (6.10), incl	1/2	13.
Stock lengths and stock lengths with ends	1	25

(Applicable to all Specifications Listed Below)
TABLE 8 SCHEDULE OF MINIMUM LENGTH AND MAXIMUM WEIGHT OF ENDS FOR MILL LENGTHS, SPECIFIC LENGTHS WITH ENDS AND STOCK LENGTH WITH ENDS

NOMINAL LENGTH, FT (m)	0.050 in. (1.27mm) and Under in Thickness		Over 0.050 to 0.125 in. (1.27 to 3.18 mm) incl, in Thickness		Over 0.125 to 0.250 in. 3.18 to 6.35mm) incl, in Thickness				
	Minimum Length of Shortest Piece	Maximum Permissible Weight of Ends, Percent of Lot Weight	Minimum Length of Shortest Piece	Maximum Permissible Weight of Ends, Percent of Lot Weight	Minimum Length of Shortest Piece	Maximum Permissible Weight of Ends, Percent of Lot Weight			
							FT	m	FT
6 (1.83) to 8 (2.44), incl	4	1.22	20	4	1.22	25	3	0.914	30
8 (2.44) to 10 (3.05), incl	6	1.83	25	5	1.52	30	4	1.22	35
10 (3.05) to 14 (4.27), incl	7	2.13	30	6	1.83	35	5	1.52	40

ASTM B248 Specifications:

B36, Brass Plate, Sheet, Strip, and Rolled Bar
 B97, Copper-Silicon Alloy Plate, Sheet, Strip,
 and Rolled Bar for General Purposes
 B103, Phosphor Bronze Plate, Sheet, Strip, and
 and Rolled Bar
 B121, Leaded Brass Plate, Sheet, Strip, and
 Rolled Bar
 B122, Copper-Nickel-Zinc Alloy (Nickel Silver)
 and Copper-Nickel Alloy Plate, Sheet,
 Strip, and Rolled Bar
 B152, Copper Sheet, Strip, Plate & Rolled Bar
 B169, Aluminum Bronze Plate, Sheet, Strip & Rolled Bar

B194, Copper-Beryllium Alloy Plate, Sheet, Strip & Rolled Bar
 B291, Copper-Zinc-Manganese Alloy (Manganese Brass)
 B422, Copper-Nickel-Silicon Alloy Sheet and Strip
 B465, Copper-Iron Alloy Plate, Sheet, Strip and Rolled Bar
 B534, Copper-Cobalt-Beryllium Alloy (Copper Alloy No. 175)
 Plate, Sheet, Strip and Rolled Bar
 B591, Copper-Zinc-Tin Alloys, Plate, Sheet, Strip & Rolled Bar
 B592, Copper-Zinc-Aluminum-Cobalt Alloy, Plate, Sheet, Strip
 and Rolled Bar

** The full text of this ASTM is available for review at 78-567, or, for more information, call Norma, 2577.

BRASS, CU BE, PH BRZ, COPPER AND MISC ALLOYS

TOLERANCES

ASTM B248

TABLE 9 LENGTH TOLERANCES FOR SQUARE-SHEARED METAL IN ALL WIDTHS 120 IN. (3.05) AND UNDER (Applicable to all Specifications Listed Below)

LENGTH, IN (mm)	LENGTH TOLERANCE, PLUS AND MINUM					
	FOR THICKNESS UP TO 1/16 IN (1.59mm), incl		FOR THICKNESSES Over 1/16 to 1/8 IN (1.59 to 3.18mm), incl.		FOR THICKNESSES Over 1/8 IN (3.18mm)	
	IN	mm	IN	mm	IN	mm
20 (0.508) and under	1/32	0.79	3/64	1.2	1/16	1.6
Over 20 to 36 (0.508 to 0.914), incl	1/64	1.2	3/64	1.2	1/16	1.6
Over 36 to 120 (0.914 to 3.05), incl	1/16	1.6	1/16	1.6	1/16	1.6

TABLE 10 LENGTH TOLERANCES FOR SAWED METAL (Applicable to all Specifications Listed Below)

WIDTH, IN (mm)	LENGTH TOLERANCE	
	IN	mm
Up to 120 (3050), incl	1/4	64

TABLE 11 STRAIGHTNESS TOLERANCES FOR SLIT METAL OR SLIT METAL EITHER STRAIGHTENED OR EDGE-ROLLED (Applicable to all Specifications Listed Below)

WIDTH, IN (mm)	STRAIGHTNESS TOLERANCE					
	AS SLIT ONLY				AS SLIT AND EITHER STRAIGHTENED OR EDGE ROLLED	
	SHIPPED IN ROLLS		SHIPPED FLAT		SHIPPED FLAT, IN ROLLS, OR ON BUCKS	
	IN	mm	IN	mm	IN	mm
Over 1/4 to 3/8 (6.35 to 9.53), incl	2	51	1-1/2	38	1/2	13
Over 3/8 to 1/2 (9.53 to 12.7), incl	1-1/2	38	1	25	1/2	13
Over 1/2 to 1 (12.7 to 25.4), incl	1	25	3/4	19	1/2	13
Over 1 to 2 (25.4 to 50.8), incl	5/8	16	5/8	16	3/8	9.5
Over 2 to 4 (50.8 to 102), incl	1/2	13	1/2	13	3/8	9.5
Over 4 (102)	3/8	9.5	3/8	9.5	3/8	9.5

TABLE 12 STRAIGHTNESS TOLERANCES FOR SQUARE-SHEARED METAL (Applicable to all Specifications Listed Below)

THICKNESS, IN (mm)	STRAIGHT TOLERANCES			
	Up to 10 in (254mm), incl in Width		Over 10 in (254mm), in Width	
	IN	mm	IN	mm
1/8 (3.18) and under	1/16	1.6	1/32	0.79
Over 1/8 to 3/16 (3.18 to 4.78), incl	1/8	3.2	3/64	1.2
Over 3/16 (4.78)	1/8	3.2	1/16	1.6

TABLE 13 STRAIGHTNESS TOLERANCE FOR SAWED METAL (Applicable to all Specifications Listed Below)

WIDTH, IN (mm)	STRAIGHTNESS TOLERANCES	
	IN	mm
3 (76.2) and under	1/16	1.6
Over 3 (76.2)	3/64	1.2

ASTM B248 Specifications:

- B36, Brass Plate, Sheet, Strip, and Rolled Bar
- B97, Copper-Silicon Alloy Plate, Sheet, Strip, and Rolled Bar For General Purposes
- B103, Phosphor Bronze Plate, Sheet, Strip, and Rolled Bar
- B121, Leaded Brass Plate, Sheet, Strip, and Rolled Bar
- B122, Copper-Nickel-Zinc Alloy (Nickel Silver) and Copper-Nickel Alloy Plate, Sheet, Strip, and Rolled Bar
- B152, Copper Sheet, Strip, Plate & Rolled Bar

- B169, Aluminum Bronze Plate, Sheet, Strip & Rolled Bar
- B194, Copper-Beryllium Alloy Plate, Sheet, Strip and Rolled Bar
- B291, Copper-Zinc-Manganese Alloy (Manganese Brass)
- B422, Copper-Nickel-Silicon Alloy Sheet and Strip
- B465, Copper-Iron Alloy Plate, Sheet, Strip, and Rolled Bar
- B534, Copper-Cobalt-Beryllium Alloy (Copper Alloy No. 175) Plate, Sheet, Strip and Rolled Bar
- B591, Copper-Zinc-Tin Alloys, Plate, Sheet, Strip and Rolled Bar
- B592, Copper-Zinc-Aluminum-Cobalt Alloy, Plate, Sheet, Strip and Rolled Bar

**The full text of this ASTM is available for review at 78-567, or, for more information, call Norma, 2577.

BRASS, CU BE, PH BRZ, COPPER AND MISC ALLOYS

TOLERANCES

ASTM B248

TABLE 14 LOT WEIGHT TOLERANCES FOR HOT-ROLLED SHEET AND PLATE (Applicable to Specification B97(Copper Alloys No. 655), and B152)

THICKNESS, IN (mm)	WEIGHT TOLERANCES, PLUS AND MINUS, PERCENTAGE OF THEORETICAL WEIGHT				
	48 in (1.22m) and under in Width	Over 48 to 60 in (1.22 to 1.52m), incl in Width	Over 60 to 72 in (1.52 to 1.83m), incl in Width	Over 72 to 90 in (1.83 to 2.29m), incl in Width	Over 90 to 110 in (2.29 to 2.79m), incl in Width
1/8 (3.18) and under	8	9.5	11	12.5	14
Over 1/8 to 3/16 (3.18 to 4.78), incl	6.5	8	9.5	11	12.5
Over 3/16 to 1/4 (4.78 to 6.35), incl	6	7.5	8.5	9	10
Over 1/4 to 5/16 (6.35 to 7.92), incl	5.5	7	7	8.5	9
Over 5/16 to 3/8 (7.92 to 9.53), incl	5	6	7	7.5	8
Over 3/8 to 7/16 (9.53 to 11.1), incl	4.5	5	6	7	7.5
Over 7/16 to 1/2 (11.1 to 12.7), incl	4	4.5	5.5	6	6.5
Over 1/2 to 5/8 (12.7 to 15.9), incl	3.5	4.5	5	5.5	6
Over 5/8 to 3/4 (15.9 to 19.1), incl	3	4	4.5	5	5.5
Over 3/4 to 1 (19.1 to 25.4), incl	2.75	3.5	4	4.5	5
Over 1 to 1-1/2 (25.4 to 38.1), incl	2.5	3	3.5	4	4.5
Over 1-1/2 to 2 (38.1 to 50.8), incl	2.25	2.75	3.25	3.75	4.25

TABLE 15 TOLERANCES FOR RADIUS OF COMERCIAALLY SQUARE CORNERS OF ROLLED OR DRAWN EDGES WITH SQUARE CORNERS (Applicable to all Specifications Listed Below)

THICKNESS, IN (mm)	PERMISSIBLE RADIUS OF CORNERS, MAX, IN (mm)
0.032 (0.813) to 0.064 (1.626), incl	0.010 (0.25)
Over 0.064 (1.626) to 0.188 (4.78), incl	0.016 (0.41)
Over 0.188 (4.78) to 1 (25.4), incl	1/12 (0.794)

TABLE 16 TOLERANCES FOR RADIUS ON CORNERS ROLLED OR DRAWN EDGES WITH ROUNDED CORNERS (Applicable to all Specifications Listed Below)

THICKNESS, IN (mm)	RADIUS OF CORNERS, IN ()	
	MIN	MAX
Up to 0.125 (3.2), incl		
Over 0.125 (3.2) to 0.188 (4.78), incl	0.016 (0.41)	0.048 (1.24)
Over 0.188 (4.8) to 1 (25.4), incl	0.031 (0.80)	0.094 (2.39)
Over 1 (25.4) to 2 (50.8), incl	0.063 (1.62)	0.188 (4.78)

TABLE 17 TOLERANCES FOR RADIUS OF ROLLER OR DRAWN ROUNDED EDGES (Applicable to all Specifications Listed Below)

THICKNESS, IN (mm)	RADIUS OF EDGES	
	MIN	MAX
Up to 0.188 (4.78), incl	3/4 t	1-3/4 t
Over 0.188 (4.78)	1 t	1-1/2 t

TABLE 18 TOLERANCES FOR RADUIS OF ROLLED OR DRAWN FULL-ROUNDED EDGES (Applicable to all Specifications Listed Below)

THICKNESS, IN (mm)	RADIUS OF EDGES	
	MIN	MAX
All thicknesses	1/2 t	3/4 t

ASTM B248 Specifications:

B36, Brass Plate, Sheet, Strip, and Rolled Bar
 B97, Copper-Silicon Alloy Plate, Sheet, Strip, and Rolled Bar for General Purposes
 B103, Phosphor Bronze Plate, Sheet, Strip, and Rolled Bar
 B121, Leaded Brass Plate, Sheet, Strip, and Rolled Bar
 B122, Copper-Nickel-Zinc Alloy (Nickel Silver) and Copper-Nickel Alloy Plate, Sheet, Strip, and Rolled Bar
 B152, Copper Sheet, Strip, Plate and Rolled Bar

B169, Aluminum Bronze Plate, Sheet, Strip and Rolled Bar
 B194, Copper-Beryllium Alloy Plate, Sheet, Strip and Rolled Bar
 B291, Copper-Zinc-Manganese Alloy (Manganese Brass)
 B422, Copper-Nickel-Silicon Alloy Sheet and Strip
 B465, Copper-Iron Alloy Plate, Sheet, Strip, and Rolled Bar
 B534, Copper-Cobalt-Beryllium Alloy (Copper Alloy No. 175) Plate, Sheet, Strip and Rolled Bar
 B591, Copper-Zinc-Tin Alloys, Plate, Sheet, Strip and Rolled Bar
 B592, Copper-Zinc-Aluminum-Cobalt Alloy, Plate, Sheet, Strip and Rolled Bar

** The full text of this ASTM is available for review at 78-567, or, for more information, call Norma, 2577.

BRASS, CU BE, PH BRZ, COPPER AND MISC ALLOYS

TOLERANCES

ASTM B249

TABLE 1 TOLERANCES FOR DIAMETER OR DISTANCE BETWEEN PARALLEL SURFACES OF COLD-DRAWN ROD
(Applicable to Specifications B 16, B 21, B 98 (Alloy 651), B 133, B 140, B 301, and B 453)

DIAMETER OR DISTANCE BETWEEN PARALLEL SURFACES, IN. (mm)	TOLERANCES, PLUS AND MINUS, IN. (mm)	
	Rounds	Hexagons, Octagons
Up to .150 (3.81) incl.	.0013 (.033)	.0025 (.064)
Over .150 (3.81) to .500 (12.7) incl.	.0015 (.038)	.0030 (.076)
Over .500 (12.7) to 1.00 (25.4) incl.	.0020 (.051)	.0040 (.100)
Over 1.00 (25.4) to 2.00 (50.8) incl.	.0025 (.064)	.0050 (.130)
Over 2.00 (50.8)	.150	.300

TABLE 2 TOLERANCES FOR DIAMETER OR DISTANCE BETWEEN PARALLEL SURFACES OF COLD-DRAWN ROD
(Applicable to Specifications B 98 (Alloys 655 and 661), B 138, B 139, B 150, B 151, B 196, B 371, B 411, and B 441)

DIAMETER OR DISTANCE BETWEEN PARALLEL SURFACES, IN. (mm)	TOLERANCES, PLUS AND MINUS, IN. (mm)	
	Rounds	Hexagons, Octagons
Up to .150 (3.81) incl.	.002 (.051)	
Over .150 (3.81) to .500 (12.7) incl.	.002 (.051)	.004 (.100)
Over .500 (12.7) to 1.00 (25.4) incl.	.003 (.076)	.005 (.130)
Over 1.00 (25.4) to 2.00 (50.8) incl.	.004 (.100)	.006 (.150)
Over 2.00 (50.8)	.200	.400

TABLE 3 DIAMETER TOLERANCES FOR PISTON-FINISH ROD (Applicable to Specifications B 21, B 138, B 139, and B 150)

DIAMETER, IN.	TOLERANCES, PLUS AND MINUS, IN.
Over .500 to 1.00 incl.	.0013
Over 1.00 to 2.00 incl.	.0015
Over 2.00	.1000

TABLE 4 TOLERANCES FOR DIAMETER OR DISTANCE BETWEEN PARALLEL SURFACES OF AS-EXTRUDED ROD AND BAR
(Applicable to Specifications B21, B124 (Copper Alloys UNS Nos. C37700, C46400, C48500, C63000, C63900, C64200, C64210, and C67500), B138 (Copper Alloy UNS No. C67500), and B150.)

DIAMETER OR DISTANCE BETWEEN PARALLEL SURFACES, IN	TOLERANCES, PLUS AND MINUS, IN	
	ROUNDS, SQUARES, RECTANGLES, HEXAGONS, OCTAGONS	
Up to 1.00 incl	0.010	
Over 1.00 to 2.00 incl	0.015	
Over 2.00 to 3.00 incl	0.025	
Over 3.00 to 3.50 incl	0.035	
Over 3.50 to 4.00 incl	0.060	

TABLE 5 TOLERANCES FOR DIAMETER OR DISTANCE BETWEEN PARALLEL SURFACES OF AS-EXTRUDED ROD AND BAR
(Applicable to Specifications B98 (Copper UNS Nos. C65100, C65500, and C65800) and B124 (Copper UNS Nos. C11000, C14500, C65500, and C77400), and B138 (Copper UNS No. C67000.)

DIAMETER OR DISTANCE BETWEEN PARALLEL SURFACES, IN	TOLERANCES, PLUS AND MINUS, IN	
	ROUNDS, SQUARES, RECTANGLES, HEXAGONS, OCTAGONS	
Up to 1.00 incl	0.020	
Over 1.00 to 2.00 incl	0.030	
Over 2.00 to 3.00 incl	0.050	
Over 3.00 to 3.50 incl	0.070	
Over 3.50 to 4.00 incl	0.120	

12

BRASS, CU BE, PH BRZ, COPPER AND MISC ALLOYS

TOLERANCES ASTM B249

TABLE 6 DIAMETER TOLERANCES FOR HOT-ROLLED ROUND ROD (Applicable to Specifications B 98, B 124, B 138, B 150, B 196, and B 441.)

DIAMETER, IN.	TOLERANCES, PLUS AND MINUS, IN.
.250 only	+ .020 - .010
Over .250 to .750 incl.	.015
Over .750 to 1.25 incl.	.020
Over 1.25 to 1.50 incl.	.030
Over 1.50 to 3.00 incl.	.062
Over 3.00	.125

TABLE 7 THICKNESS TOLERANCES FOR RECTANGULAR AND SQUARE BAR (Applicable to Specifications B 133 and B 301)
THICKNESS TOLERANCES, PLUS AND MINUS, IN., FOR WIDTHS GIVEN IN INCHES

	.500 AND UNDER	OVER .500 to 1.250 INCL.	OVER 1.250 to 2.00 INCL.	OVER 2.00 to 4.00 INCL.	OVER 4.00 to 8.00 INCL.	OVER 8.00 to 12.00 INCL.
Over .188 to .500 incl.	.003	.0030	.0035	.0040	.0045	.0055
Over .500 to 1.00 incl.	---	.0040	.0040	.0045	.0050	.0060
Over 1.00 to 2.00 incl.	---	.0045	.0045	.0050	.0060	---
Over 2.00 to 4.00 incl.	---	---	---	.3000	---	---

TABLE 8 THICKNESS TOLERANCES FOR RECTANGULAR AND SQUARE BAR (Applicable to Specifications B 16, B 21, B 98, (Copper Alloy UNS No. C65100), and B140.)
THICKNESS TOLERANCES, PLUS AND MINUS, IN., FOR WIDTHS GIVEN IN INCHES

THICKNESS, IN.	.500 AND UNDER	OVER .500 to 1.250 INCL.	OVER 1.250 to 2.00 INCL.	OVER 2.00 to 4.00 INCL.	OVER 4.00 to 8.00 INCL.	OVER 8.00 to 12.00 INCL.
Over .188 to .500 incl.	.0035	.0040	.0045	.0045	.006	.008
Over .500 to 1.00 incl.	---	.0045	.0050	.0050	.007	.009
Over 1.00 to 2.00 incl.	---	.0050	.0050	.0060	.008	---
Over 2.00 to 4.00 incl.	---	---	---	.3000	---	---

TABLE 9 THICKNESS TOLERANCES FOR RECTANGULAR AND SQUARE BAR (Applicable to Specifications B 98 (Alloys 655, 658, and 661), B 138, B 139, B 150, B 151, B 196, B 411, and B 441)
THICKNESS TOLERANCES, PLUS AND MINUS, IN., FOR WIDTHS GIVEN IN INCHES

THICKNESS, IN.	.500 AND UNDER	OVER .500 to 1.250 INCL.	OVER 1.250 to 2.00 INCL.	OVER 2.00 to 4.00 INCL.	OVER 4.00 to 8.00 INCL.	OVER 8.00 to 12.00 INCL.
Over .188 to .500 incl.	.005	.005	.006	.007	.009	.012
Over .500 to 1.00 incl.	---	.006	.007	.008	.010	.013
Over 1.00 to 2.00 incl.	---	.006	.007	.009	.011	---
Over 2.00 to 4.00 incl.	---	---	---	.500	---	---

TABLE 10 WIDTH TOLERANCES FOR RECTANGULAR BAR (Applicable to Specifications B 16, B 21, B 98 (Alloy 651), B 133, B 140 and B 301.)

WIDTH, IN.	TOLERANCES, PLUS AND MINUS, IN.
Over .188 to .500 incl.	.0035
Over .500 to 1.25 incl.	.0050
Over 1.25 to 2.00 incl.	.0080
Over 2.00 to 4.00 incl.	.0120
Over 4.00 to 12.00 incl.	.3000

BRASS, CU BE, PH BRZ, COPPER AND MISC ALLOYS

TOLERANCES ASTM B249

TABLE 11 WIDTH TOLERANCES FOR RECTANGULAR BAR

(Applicable to Specifications B98 (Copper Alloy UNS No.s C65500, C65800, and C66100), B138, B139, B150, B151, B196, B411, and B441.)

WIDTH, IN.	TOLERANCES, PLUS AND MINUS, IN.
Over 0.188 to 0.500 incl.	.005
Over 0.500 to 1.25 incl.	.007
Over 1.25 to 2.00 incl.	.010
Over 2.00 to 4.00 incl.	.015
Over 4.00 to 12.00 incl.	.50

TABLE 12 LENGTH TOLERANCES FOR ROD, BAR, AND SHAPES (FULL-LENGTH PIECES SPECIFIC AND STOCK LENGTHS WITH OR WITHOUT ENDS)

(Applicable to Specifications B16, B21, B98, B133, B138, B139, B140, B150, B151, B196, B301, B371, B411, B441, and B453.)

LENGTH CLASSIFICATION	TOLERANCES, ALL PLUS, IN (Applicable only to Full-Length Pieces)
Specific lengths	3/8
Specific lengths with ends	1
Stock lengths with or without ends	1

TABLE 13 SCHEDULE OF LENGTHS (SPECIFIC AND STOCK) WITH ENDS FOR ROD BAR

(Applicable to Specifications B16, B21, B133, B138 (Copper Alloy UNS No. C67500), B140, B301, and B453.)

DIAMETER OR DISTANCE BETWEEN PARALLEL SURFACES FOR ROUND, HEXAGONAL, AND OCTAGONAL ROD, AND SQUARE BAR, IN.	RECTANGULAR BAR, AREA, IN.	NOMINAL LENGTH, FT.	SHORTEST PERMISSIBLE LENGTH, PERCENT OF NOMINAL LENGTH	MAXIMUM PERMISSIBLE WEIGHT OF ENDS, PERCENT OF LOT WEIGHT
0.500 and under	0.250 and under	6 to 14 incl	75	20
Over 0.500 to 1.00 incl	Over 0.250 to 1.00 incl	6 to 14 incl	70	30
Over 1.00 to 1.50 incl	Over 1.00 to 2.25 incl	6 to 12 incl	60	40
Over 1.50 to 2.00 incl	Over 2.25 to 4.00 incl	6 to 12 incl	50	45
Over 2.00 to 3.00 incl	Over 4.00 to 9.00 incl	6 to 10 incl	40	50

TABLE 14 SCHEDULE OF LENGTHS (SPECIFIC AND STOCK) WITH ENDS FOR ROD AND BAR

(Applicable to Specifications B98, B138 (Copper Alloy UNS No. C67000), B139, B150, B151, B196, B371, B411, and B441.)

Diameter or Distance Between Parallel surfaces for round Hexagonal, and Octagonal Rod, and Square Bar, In.	Rectangular Bar, Area, In.	Nominal Length Ft.	Shortest Permissible Length, Percent of Nominal Length	Maximum Permissible Weight of Ends, Percent of Lot Weight
0.500 and under	0.250 and under	6 to 12 incl	65	30
Over 0.500 to 1.00 incl	Over 0.250 to 1.00 incl	6 to 12 incl	60	40
Over 1.00 to 1.50 incl	Over 1.00 to 2.25 incl	6 to 10 incl	50	50
Over 1.50 to 2.00 incl	Over 2.25 to 4.00 incl	6 to 10 incl	40	60

** The full text of this ASTM is available for review at 78-567, or, for more information, call Norma, 2577.

BRASS, CU BE, PH BRZ, COPPER AND MISC ALLOYS

TOLERANCES

ASTM B249

TABLE 15 STRAIGHTNESS TOLERANCES FOR ROD, BAR AND SHAPES

FOR GENERAL USE (Applicable to Specifications B 16, B 21, B 98, B 133, B 138, B 139, B 140, B 150, B 151, B 196, B 301, B 371, B 411, B 441, and B 453.)

FORM AND SIZE, IN.	LENGTH, FT.	MAXIMUM CURVATURE (DEPTH OF ARC), IN.
Drawn rod	up to 2	1/32 (0.79)
	incl 2	1/32 (0.79) in any 2 ft portion
	incl 5	1/8 (3.2) in any 5 ft portion
	10 and over	1/2 (13) in any 10 ft portion
Bar and shapes (rolled or drawn)	6 and over	1/2 (13) in any 6 ft (1.83m) portion

DRAWN ROD -- FOR AUTOMATIC SCREW MACHINE USE (Applicable to Specifications B 16, B 140, B 301, and B 453.)

Rounds only: Under 1/4 1/4 and over Local departure from straightness, 1/4 and over only	10 and over	1/2 (13) in any 10 ft portion
	10 and over	1/4 (6.4) in any 10 ft portion
	. . .	1/64 (0.40) in any 1 ft portion of the total length
Hexagons and Octagons: Under 1/4 1/4 and over	10 and over	1/2 (13) in any 10 ft portion
	10 and over	3/8 (9.5) in any 10 ft portion

TABLE 16 STRAIGHTNESS TOLERANCES FOR SHAFTING (Applicable to Specifications B 21, B 138, B 139, and B 150.)

LENGTH OF SHAFT, FT.	MAXIMUM PERMISSIBLE DEPARTURE FROM STRAIGHTNESS OF EITHER CENTER OR END PORTIONS, IN.	MINIMUM DIAMETER APPLICABLE FOR LENGTH INDICATED, IN.
Up to 6, incl	0.005	1/2
7	0.007	1/2
8	0.009	1/2
9	0.012	1/2
10	0.014	1/2
11	0.017	1/2
12	0.020	1/2
14	0.028	5/8
16	0.036	3/4
18	0.045	1
20	0.055	1-1/4
22	0.068	1-1/2
24	0.078	1-3/4
26	0.094	2

TABLE 17 DIAMETER TOLERANCES FOR HOT-FORGED ROD AND BAR (Applicable to Specification B 138)

DIAMETER OR DISTANCE BETWEEN PARALLEL SURFACES, IN.	TOLERANCES, ALL PLUS, IN.	
	AS-FORGED	ROUGH-TURNED
Over 3.50	0.125	0.050

BRASS, CU BE, PH BRZ, COPPER AND MISC ALLOYS

TOLERANCES ASTM B250

TABLE 1 TOLERANCES FOR DIAMETER OR DISTANCE BETWEEN PARALLEL SURFACES OF WIRE (Applicable for Specifications B 16, B 99 (Alloy 651), and B 134)

DIAMETER OR DISTANCE BETWEEN PARALLEL SURFACES, IN. (mm)	TOLERANCES, PLUS AND MINUS, IN. (mm)	
	Rounds	Hexagons, Octagons
Up to .010 (.254) incl.	.0001 (.0025)	
Over .010 (.254) to .020 (.508) incl.	.0002 (.0051)	
Over .020 (.508) to .030 (.762) incl.	.0003 (.0076)	
Over .030 (.762) to .040 (1.02) incl.	.0004 (.010)	.0008 (.020)
Over .040 (1.02) to .050 (1.27) incl.	.0005 (.013)	.0010 (.025)
Over .050 (1.27) to .060 (1.52) incl.	.0006 (.015)	.0012 (.030)
Over .060 (1.52) to .080 (2.03) incl.	.0008 (.020)	.0016 (.041)
Over .080 (2.03) to .150 (3.81) incl.	.0010 (.025)	.002 (.051)
Over .150 (3.81) to .500 (12.7) incl.	.0015 (.038)	.003 (.076)
Over .500 (12.7) to .750 (19.1) incl.	.002 (.051)	.004 (1.00)

TABLE 2 TOLERANCES FOR DIAMETER OR DISTANCE BETWEEN PARALLEL SURFACES OF WIRE (Applicable to Specifications B 99 (Alloy 655), B 159, B 197, B 206, and B 412.)

DIAMETER OR DISTANCE BETWEEN PARALLEL SURFACES, IN.	TOLERANCES, PLUS AND MINUS, IN.	
	ROUND	HEXAGONAL, OCTAGONAL
Up to .010 incl.	.0002	---
Over .010 to .020 incl.	.0003	---
Over .020 to .030 incl.	.0005	---
Over .030 to .040 incl.	.0007	.002
Over .040 to .050 incl.	.0008	.003
Over .050 to .060 incl.	.0010	.003
Over .060 to .080 incl.	.0015	.004
Over .080 to .150 incl.	.0020	.004
Over .150 to .500 incl.	.0020	.004
Over .500 to .750 incl.	.0030	.005

TABLE 3 THICKNESS TOLERANCES FOR FLAT (RECTANGULAR AND SQUARE) WIRE (Applicable to Specification B 134.)

THICKNESS, IN.	THICKNESS TOLERANCES, PLUS AND MINUS, IN. FOR WIDTHS GIVEN IN INCHES	
	UP TO .500 INCL.	OVER .500 TO 1.250 INCL.
Up to .013 incl.	.0010	.0013
Over .013 to .050 incl.	.0013	.0015
Over .050 to .090 incl.	.0015	.0020
Over .090 to .130 incl.	.0020	.0025
Over .130 to .188 incl.	.0030	.0035

TABLE 4 THICKNESS TOLERANCES FOR FLAT (RECTANGULAR AND SQUARE WIRE) (Applicable to Specifications B 159, B 197, B 206, and B 412.)

THICKNESS, IN.	THICKNESS TOLERANCES, PLUS AND MINUS, IN. FOR WIDTHS GIVEN IN INCHES	
	UP TO .500 INCL.	OVER .500 TO 1.250 INCL.
Up to .050 incl.	.0015	.0020
Over .050 to .090 incl.	.0020	.0030
Over .090 to .130 incl.	.0030	.0040
Over .130 to .188 incl.	.0040	.0045

TABLE 5 WIDTH TOLERANCES FOR FLAT (RECTANGULAR) WIRE (Applicable to Specification B 134.)

(FOR SQUARE WIRE USE THICKNESS TOLERANCES IN TABLE 3)

WIDTH, IN.	TOLERANCES, PLUS AND MINUS
Up to .050 incl.	.0013
Over .050 to .090 incl.	.0015
Over .090 to .130 incl.	.0020
Over .130 to .188 incl.	.0030
Over .188 to .500 incl.	.0035
Over .500 to 1.25 incl.	.0050

TABLE 6 WIDTH TOLERANCES FOR FLAT (RECTANGULAR) WIRE (Applicable to Specifications B 159, B 197, B 206, and B 412.)

(FOR SQUARE WIRE USE THICKNESS TOLERANCES IN TABLE 4)

WIDTH, IN.	TOLERANCES, PLUS AND MINUS
Up to .050 incl.	.0015
Over .050 to .090 incl.	.0020
Over .090 to .130 incl.	.0030
Over .130 to .188 incl.	.0040
Over .188 to .500 incl.	.0050
Over .500 to 1.25 incl.	.0070

**The full text of this ASTM is available for review at 78-567, or, for more information, call Norma, Ext. 2577.

BRASS, CU BE, PH BRZ, COPPER AND MISC ALLOYS

TOLERANCES ASTM B250

TABLE 7 LENGTH TOLERANCES FOR STRAIGHT LENGTHS (SPECIFIC AND STOCK) OF FLAT (RECTANGULAR AND SQUARE) WIRE
(Applicable to Specifications B134, B159, B197, B206, and B412)

LENGTHS	LENGTH TOLERANCES APPLICABLE ONLY TO FULL LENGTH PIECES, IN.
Specific lengths	3/8
Specific lengths with ends	1
Stock lengths with or without ends	1

Tolerances are all plus; if all minum tolerances are desired, use the same values; if tolerances plus and minus are desired, halve the values given.

As stock lengths are cut and placed in stock in advance of orders, departure from this tolerance is not practicable.

TABLE 8 SCHEDULE OF LENGTHS (SPECIFIC AND STOCK) WITH ENDS FOR FLAT (RECTANGULAR AND SQUARE) WIRE FURNISHED IN STRAIGHT LENGTHS
(Applicable to Specifications B134, B159, B197, B206, and B412)

NOMINAL LENGTH, FT.	SHORTEST PERMISSIBLE LENGTH (in percent of nominal length)	MAXIMUM PERMISSIBLE WEIGHT OF ENDS (in percent of lot weight)
6 to 14 incl	75	20

TABLE 9 STRAIGHTNESS TOLERANCES FOR FLAT (RECTANGULAR AND SQUARE) WIRES
(Applicable Specifications B134, B159, B197, B206, and B412)

Applicable to any longitudinal edge of material supplied in nominally flat straight lengths and in rolls or on bucks.	
For material having cross-sectional area of 0.010 in. and over and a thickness of 0.010 in and over, furnished in straight lengths, in rolls or on bucks.	1/2 in maximum edgewise curvature (depth of arc) in any 6 ft portion of the total length.
For material having a cross-sectional area of less than 0.010 in, or a thickness of less than 0.010 in., and all material furnished on reels or on stagger wound rolls.	No straightness tolerances established

BRASS TUBE

TOLERANCES ASTM B251

TABLE 1 WALL THICKNESS TOLERANCES FOR COPPER AND COPPER-ALLOY TUBE
(Applicable to Specifications B 68, B 75, and B 135.)

WALL THICKNESS, IN.	OUTSIDE DIAMETER, IN.						
	Over .031 to .125 incl.	Over .125 to .625 incl.	Over .625 to 1 incl.	Over 1 to 2 incl.	Over 2 to 4 incl.	Over 4 to 7 incl.	Over 7 to 10 incl.
Up to .017 incl.	.002	.001	.0015	.002			
Over .017 to .024 incl.	.003	.002	.002	.0025			
Over .024 to .034 incl.	.003	.0025	.0025	.003	.004		
Over .034 to .057 incl.	.003	.003	.0035	.0035	.005	.007	
Over .057 to .082 incl.		.0035	.004	.004	.006	.008	.010
Over .082 to .119 incl.		.004	.005	.005	.007	.009	.011
Over .119 to .164 incl.		.005	.006	.006	.008	.010	.012
Over .164 to .219 incl.		.007	.0075	.008	.010	.012	.014
Over .219 to .283			.009	.010	.012	.014	.016

TABLE 2 AVERAGE DIAMETER TOLERANCES FOR COPPER AND COPPER-ALLOY TUBE (Applicable to Specifications B 68, B 75, and B 135.)

SPECIFIED DIAMETER, IN.	DIAMETER TO WHICH TOLERANCE APPLIES	TOLERANCE, PLUS AND MINUS, IN.
Up to .125 incl.	inside or outside	.0020
Over .125 to .625 incl.	inside or outside	.0020
Over .625 to 1.00 incl.	inside or outside	.0025
Over 1.00 to 2.00 incl.	inside or outside	.0030
Over 2.00 to 3.00 incl.	inside or outside	.0040
Over 3.00 to 4.00 incl.	inside or outside	.0050
Over 4.00 to 5.00 incl.	inside or outside	.0060
Over 5.00 to 6.00 incl.	inside or outside	.0070
Over 6.00 to 8.00 incl.	inside or outside	.0080
Over 8.00 to 10.00 incl.	inside or outside	.0100

TABLE 3 LENGTH TOLERANCES FOR COPPER AND COPPER-ALLOY TUBE, STRAIGHT LENGTHS
(Applicable to Specifications B68, B75, B135, and B466)

Note--Tolerances are all plus; if all minus tolerances are desired, use the same values; if tolerances plus and minus are desired, halve the values given

Length	Tolerances, in. Applicable Only to Full-Length Pieces		
	For Major Outside Dimensions up to 1 in., incl.	For Major Outside Dimensions over 1 in. to 4 in., incl.	For Major Outside Dimensions over 4 in.
Specific lengths:			
Up to 6 in., incl	1/32	1/16	---
Over 6 in. to 2 ft., incl	1/16	3/32	1/8
Over 2 ft. to 6 ft., incl	3/32	1/8	1/4
Over 6 ft. to 14 ft., incl	1/4	1/4	1/4
Over 14 ft.	1/2	1/2	1/2
Specific lengths with ends	1	1	1
Stock lengths with or without ends	1	1	1

As stock lengths are cut and placed in stock in advance of orders, departure from this tolerance is not practicable.

TABLE 4 SCHEDULE OF TUBE LENGTHS (SPECIFIC AND STOCK) WITH ENDS FOR COPPER AND COPPER-ALLOY TUBE
(Applicable to Specifications B68, B75, B135 and B466)

MAJOR OUTSIDE DIMENSIONS, IN.	NOMINAL LENGTH, FT.	SHORTEST PERMISSIBLE LENGTH, PERCENT OF NOMINAL LENGTH	MAXIMUM PERMISSIBLE WEIGHT OF ENDS, PERCENT OF LOT WEIGHT
Up to 1, incl	6 to 20, incl	70	20
Over 1 to 2, incl	6 to 20, incl	60	25
Over 2 to 3, incl	6 to 20, incl	55	30
Over 3 to 4, incl	6 to 20, incl	50	40

BRASS TUBE

TOLERANCES ASTM B251

TABLE 5 STRAIGHTNESS TOLERANCES FOR COPPER AND COPPER-ALLOY TUBE IN ANY DRAWN TEMPER
(Applicable to Specifications B75, B135 and B466)

Note--Applies to round tube in any drawn temper from 1/4 (6.35) to 3-1/2 in. (88.9mm), incl. in outside diameter.

LENGTH, FT	MAXIMUM CURVATURE (DEPTH OF ARC), IN.
Over 3 to 6, incl.	3/16
Over 6 to 8, incl.	5/16
Over 8 to 10, incl.	1/2

Not applicable to pipe, redraw tube, extruded tube or any annealed tube.
For lengths greater than 10 ft the maximum curvature shall not exceed 1/2 in. in any 10-ft portion of the total length.

TABLE 6 WALL THICKNESS TOLERANCES FOR COPPER AND COPPER-ALLOY RECTANGULAR AND SQUARE TUBE

NOTE - Maximum deviation at any point. The following tolerances are plus and minus; if tolerances all plus or all minus are desired, double the values given. (Applicable to Specifications B 75 and B 135.)

WALL THICKNESS, IN.	DISTANCE BETWEEN OUTSIDE PARALLEL SURFACE, IN.						
	.031 to .125 INCL.	OVER .125 to .625 INCL.	OVER .625 to 1.00 INCL.	OVER 1.00 to 2.00 INCL.	OVER 2.00 to 4.00 INCL.	OVER 4.00 to 7.00 INCL.	OVER 7.00 to 10.00 INCL.
Up to .017 incl.	.0020	.0020	.0025	.0030	---	---	---
Over .017 to .024 incl.	.0030	.0025	.0030	.0035	---	---	---
Over .035 to .034 incl.	.0035	.0035	.0035	.0040	.0060	---	---
Over .034 to .057 incl.	.0040	.0040	.0045	.0050	.0070	---	---
Over .057 to .082 incl.	----	.0050	.0060	.0070	.0080	.010	.012
Over .082 to .119 incl.	----	.0070	.0080	.0090	.010	.012	.014
Over .119 to .164 incl.	----	.0090	.0100	.0110	.0120	.014	.016
Over .164 to .219 incl.	----	.0110	.0120	.0130	.0150	.017	.019
Over .219 to .283 incl.	----	----	.0150	.0160	.0180	.020	.022

TABLE 7 TOLERANCES ON DISTANCE BETWEEN PARALLEL SURFACES FOR COPPER AND COPPER-ALLOY RECTANGULAR AND SQUARE TUBE

DIMENSION A OR B (SEE SKETCHES), IN.	TOLERANCES, IN.
Up to .125 incl.	.003
Over .125 to .625 incl.	.004
Over .625 to 1.00 incl.	.005
Over 1.00 to 2.00 incl.	.006
Over 2.00 to 3.00 incl.	.007
Over 3.00 to 4.00 incl.	.008
Over 4.00 to 5.00 incl.	.009
Over 5.00 to 6.00 incl.	.010
Over 6.00 to 8.00 incl.	.011
Over 8.00 to 10.00 incl.	.012

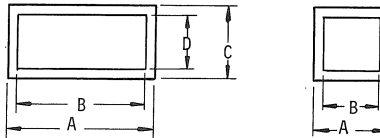

(Applicable to Specifications B 75 and B 135.)

Nominal dimension A determines tolerance applicable to both A and C.
Nominal dimension B determines tolerance applicable to both B and D.

TABLE 8 PERMISSIBLE RADII FOR COMMERCIAL SQUARE CORNERS FOR COPPER AND COPPER-ALLOY RECTANGULAR AND SQUARE TUBE
(Applicable to Specifications B75 and B135)

WALL THICKNESS, IN.	MAXIMUM RADII, IN.	
	OUTSIDE CORNERS	INSIDE CORNERS
Up to 0.058, incl.	3/64	1/32
Over 0.058 to 0.120, incl.	1/16	1/32
Over 0.120 to 0.250, incl.	3/32	1/32
Over 0.250	None established	None established

NOTES

COST CODE (CC COLUMN)

CODE	≈ VALUE with -	≈ VALUE no suffix	≈ VALUE with +
A	.2¢	.5¢	.75¢
B	1.25¢	1.5¢	2¢
C	2.5¢	3¢	3.75¢
D	4.25¢	5¢	6¢
E	7¢	8¢	10¢
F	13¢	15¢	18¢
G	22¢	25¢	35¢
H	40¢	50¢	60¢
I	65¢	75¢	\$1
J	\$1.25	\$1.50	\$2
K	\$2.50	\$3	\$3.75
L	\$4.25	\$5	\$6
M	\$7	\$8	\$10
N	\$13	\$15	\$18
O	\$22	\$25	\$35+

NOTE: Costs may vary from order to order due to order quantities, vendor, etc.

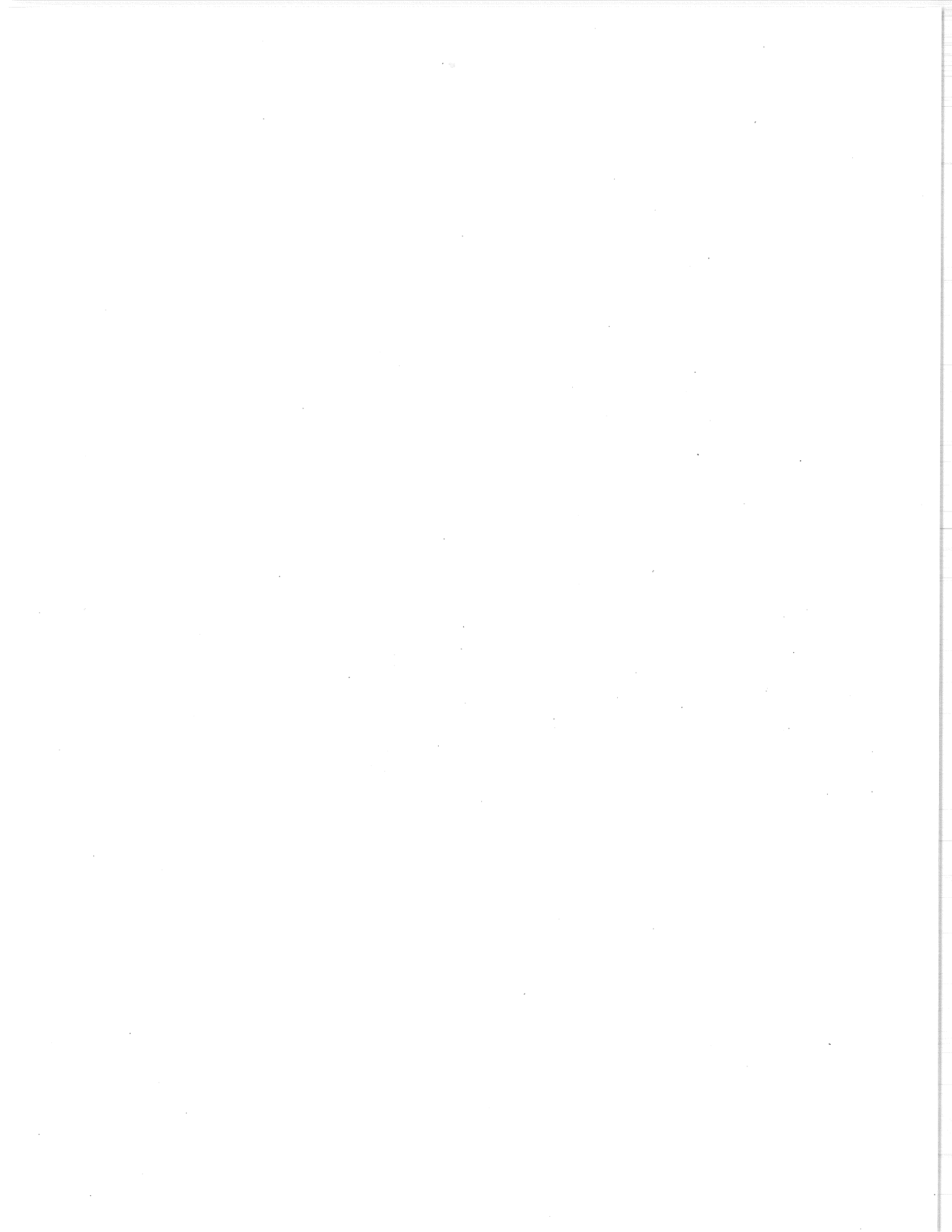

MATERIAL NAMES:

The standard used at Tek for naming parts is H6 (Cataloging Handbook). In some cases, the ASTM uses different names than H6. In such cases the H6 name will be used.

NAME	SHAPE
BAR	<p>(also Hex, Dodecagon, etc)</p> <p>$\geq .375$ (≥ 9.525 mm)</p> <p>$\geq .375$ (≥ 9.525 mm)</p> <p>$\geq .375$ (≥ 9.525 mm)</p> <p>$\geq .375$ (≥ 9.525 mm)</p> <p>$\geq .375$ (≥ 9.525 mm)</p> <p>$\geq .375$ (≥ 9.525 mm)</p> <p>$\geq .094$ (≥ 2.381 mm)</p> <p>.375 to 12" (9.525 to 304.8 mm)</p>
ROD	DO NOT USE FOR METALS (Deleted from H6)
STRIP	<p>1.25 to 12" (31.75 mm to 304.8 mm)</p> <p>$> .005$ ($> .132$ mm)</p> <p>$< .094$ (< 2.381 mm)</p>
*WIRE & *ROD	<p>(also Hex, Dodecagon, etc)</p> <p>$< .375$ (≥ 9.525 mm)</p> <p>$< .375$ (≥ 9.525 mm)</p> <p>$< .375$ (≥ 9.525 mm)</p> <p>$< .375$ (≥ 9.525 mm)</p> <p>$< .375$ (≥ 9.525 mm)</p> <p>$< .375$ (≥ 9.525 mm)</p> <p>$< .375$ (≥ 9.525 mm)</p> <p>< 1.250 (< 31.75 mm)</p> <p>$> .005$ ($> .132$ mm)</p> <p>$< .094$ (< 2.381 mm)</p> <p>*Use WIRE for metal, and ROD for nonmetallic parts.</p>
SHEET	<p>$> 12"$ across narrowest flats. (> 304.8 mm)</p> <p>$> .005$ ($> .132$ mm)</p>
FOIL & **FILM	<p>any width</p> <p>$\leq .005$ ($\leq .132$ mm)</p> <p>Use FOIL for metal, and FILM for nonmetallic parts.</p>

Some materials do not yet have specifications and may change without notice until the spec is finished. Also, some are exclusively used by one department and may be changed without notice by them.

MAGNETIC SHIELDING

TABLE OF CONTENTS

SECTION 13

	PAGES(S)
MAGNETIC SHIELDING	13-1 THRU 13-3
¹ MUMETAL	13-2
² HIGH PERMEABILITY "49"	13-2
³ MOLY PERMALOY	13-3

TEK STANDARDS PERTAINING TO MATERIALS

062-1702-00	Welding, Soldering & Brazing	D-100	Die Casting & Molding Standards
062-1703-00	Finishes, Glossary of Terms		
062-1713-00	Drafting, Aluminum Extrusions	H Series	Tooling Standards
062-1718-00	Finish Quality, Cosmetic		
062-2845-00	Mechanically Applied Finishes		
062-2848-00	Bend Allowance & Deduction	062-5818-01	Aluminum (M-150)
062-2850-00	Finish, Surface Texture	M-200	Brass
062-2854-00	Finishes, Chemical & Electromechanical	M-250	Copper
062-2856-00	Non-Additive Finishes for Brass, Copper & Copper Alloys	M-300	Copper-Beryllium
062-2860-00	Finishes, Anodized	M-350	Beryllium-Nickel
062-2863-00	Zinc Die Cast Finishes, Chromate Conversion Coatings	M-400	Phosphor-Bronze
062-2868-00	Finish, Etch Chromate & Lacquer (On Aluminum)	M-450	Steel
062-2868-01	Chromate Conversion Coating for Al Die Casting Alloy 3431	M-500	Stainless Steel
062-2871-00	Finish, Passivating	M-550	Magnetic Shielding Materials (Iron-Nickel & Nickel-Silver)
062-5818-00	General Information about Bulk Raw Materials	M-600	Copper-Nickel-Zinc

¹ REGISTERED TRADENAME OF ALLEGHENY STEEL CORPORATION.

² REGISTERED TRADENAME OF CARPENTER STEEL COMPANY.

³ REGISTERED TRADENAME OF CARPENTER STEEL COMPANY.

COST CODE

(CC COLUMN)

CODE	A	B	C	D	E	F	G	H	I	J	K	L	M	N	O
≈ VALUE with +	.75¢	2¢	3.75¢	6¢	10¢	18¢	35¢	60¢	\$1	\$2	\$3.75	\$6	\$10	\$18	\$35+
≈ VALUE no suffix	.5¢	1.5¢	3¢	5¢	8¢	15¢	25¢	50¢	75¢	\$1.50	\$3	\$5	\$8	\$15	\$25
≈ VALUE with -	.2¢	1.25¢	2.5¢	4.25¢	7¢	13¢	22¢	40¢	65¢	\$1.25	\$2.50	\$4.25	\$7	\$13	\$22

NOTE: Costs may vary from order to order due to order quantities, vendor, etc.

MAGNETIC SHIELDING (CONT)

SIZE	ALLOY	PART NUMBER	ST	CR
.014 1.0015 x 30. x 120	¹ Mumetal	3251-0712-00	CR	M /LB

SIZE	ALLOY	PART NUMBER	ST	CR
.024 x 9.25 x 120.	² High Permeability "49"	251-0817-00	CR	K /LB
.024 x 9.6 ± .031 x .120	² High Permeability "49"	251-0861-00	CR	K-/LB
.024 x 24. x 120.	² High Permeability "49"	251-0817-02	CR	L+/LB
.125 x 9.000	High Permeability "49"	251-0886-00	PP	

MAGNETIC SHIELDING MATERIALS (IRON-NICKEL) ¹ MUMETAL	
COMPOSITION (% NOMINAL):	NICKEL 77.0 COPPER 4.8 CHROMIUM 1.5 IRON 14.9
TEMPER:	1 - (For forming, bending and drawing)
MECHANICAL, PHYSICAL AND MAGNETIC PROPERTIES (COLD ROLLED)	
Specific gravity	8.5
Curie temperature, °C	398.9
Electrical Resistivity	
Microhm centimeters	56
Ohms per circular mil foot	337
Ohms per square mil foot	265
Coercive force (H _c), oersteds for B max from 5000 gauss	.015
Hysteresis loss in ergs/cm ³ /cycle for B max of 5000 gauss	20
Saturation induction (B _s), gauss	7,500
Modulus of elasticity, psi	
Cold rolled	30,000,000
Hydrogen annealed	25,000,000
Ultimate tensile strength, psi	
Mill anneal	90,000
Hydrogen anneal	64,000
Yield strength, psi	
Mill anneal	38,000
Hydrogen anneal	18,500
Elongation in 2 inches, percent	
Mill anneal	35
Hydrogen anneal	27
For complete technical data, see Allegheny Ludlum Blue Sheet EM-12 (Available from Engineering Standards).	

MAGNETIC SHIELDING MATERIALS (IRON-NICKEL) ² HIGH PERMEABILITY "49"	
COMPOSITION (% NOMINAL):	NICKEL 48.00 MANGANESE .50 SILICON .35 CARBON .05 IRON Balance
TEMPER:	Deep Drawing Quality
MECHANICAL, PHYSICAL AND MAGNETIC PROPERTIES	
Specific gravity	8.25
Curie temperature, °C	448.9
Electrical Resistivity	
Microhm centimeters	48
Ohms per circular mil foot	290
Coercive force, Oersteds from 5000 gauss	.02
Saturation inductance from H-100 oersteds, gauss	15,000
Modulus of elasticity, psi	
Cold rolled	24
Mill annealed	24
Tensile strength, psi	
Cold rolled	130,000
Mill annealed	80,000
Elongation, percent	
Cold rolled	5
Mill annealed	32
Rockwell hardness	
Cold rolled	B-100
Mill annealed	B-68
For complete technical data, see Carpenter Steel Company, Technical Data Sheet High Permeability "49" (Available from Engineering Standards).	

¹ Registered tradename of the Allegheny Steel Corporation.

² Registered tradename of the Carpenter Steel Company.

³ Changed to Moly Permaloy 9/24/74.

MAGNETIC SHIELDING (CONT)

SIZE	ALLOY	PART NUMBER	STATUS	CC
.014 x 1.600	¹ Moly Permaloy	251-0959-00	CR	M+/LB
.025 x 30 x 120	¹ Moly Permaloy	251-0591-00	CR	M /LB
.05	¹ Moly Permaloy	251-0874-00	CR	M /LB

TYPICAL CHEMICAL COMPOSITION			
Nickel		79	
Molybdenum		4	
Iron		17	
TYPICAL PHYSICAL, MECHANICAL AND MAGNETIC PROPERTIES			
	NO. 1 FORMING	NO. 2 STAMPING	HYDROGEN
	TEMPER	TEMPER	ANNEAL
Tensile Strength, psi	99,000	160,000	64,000
Yield Strength, psi	49,000	150,000	18,500
Elongation, percent in 2 inches	32	1	27
Hardness, Rockwell	B-85	C-28	B-65
Specific Gravity			8.74
Curie Temperature, °F			850
Electrical Resistivity			
Microhm centimeters			55
Ohms per cir mil ft			330
Ohms per sq mil ft			260
Coercive Force (Hc), oersteds for B _{max} from 5000 gauss			.015
Hysteresis Loss in Ergs/cm ³ /cycle for B _{max} of 5000 gauss			20
Modulus of Elasticity			
Cold Rolled			30,000,000
Hydrogen Annealed			25,000,000
Saturation Induction, gauss			8,000

¹ Registered tradename of the Allegheny Steel Corporation.

COST CODE

(CC COLUMN)

CODE	A	B	C	D	E	F	G	H	I	J	K	L	M	N	O
≈ VALUE with +	.75¢	2¢	3.75¢	6¢	10¢	18¢	35¢	60¢	\$1	\$2	\$3.75	\$6	\$10	\$18	\$35+
≈ VALUE no suffix	.5¢	1.5¢	3¢	5¢	8¢	15¢	25¢	50¢	75¢	\$1.50	\$3	\$5	\$8	\$15	\$25
≈ VALUE with -	.2¢	1.25¢	2.5¢	4.25¢	7¢	13¢	22¢	40¢	65¢	\$1.25	\$2.50	\$4.25	\$7	\$13	\$22

NOTE: Costs may vary from order to order due to order quantities, vendor, etc.

STEEL

TABLE OF CONTENTS

SECTION 14

	PAGE(S)
WIRE, BAR, STRIP	14-2
SHEET & TUBE	14-3
ROD PINION & MESH, MISC. THREADED ROD	14-3
UPDATES & NOTES	14-4
CROSS REFERENCE INDEX	14-5
MECH. PROP, WIRE & SHEET GAUGES CHARTS	14-6
THICKNESS TOLERANCES	14-7 THRU 14-11
WEIGHT (LBS PER FOOT)	14- 12
(OZ & LBS PER SQ FOOT)	

REFERENCES *

- STANDARD SPECIFICATION FOR STEEL BAR, CARBON AND ALLOY, HOT ROLLED AND COLD FINISHED, GENERAL REQUIREMENTS FOR ASTM A29.
- STANDARD SPECIFICATION FOR STEEL BARS, CARBON, COLD FINISH, STANDARD QUALITY ASTM A108.
- STANDARD SPECIFICATION FOR STEEL, CARBON, COLD-ROLLED STRIP ASTM A109.
- STANDARD SPECIFICATION FOR ELECTRODEPOSITED COATINGS OF CADMIUM ON STEEL ASTM A165.
- STANDARD SPECIFICATION FOR STEEL WIRE, MUSIC SPRING QUALITY ASTM A228.
- STANDARD SPECIFICATION FOR STEEL WIRE, OIL - TEMPERED FOR MECHANICAL SPRINGS ASTM A229.
- STANDARD SPECIFICATION FOR STEEL, CARBON, COLD-ROLLED SHEET, COMMERCIAL QUALITY ASTM A366.
- STANDARD SPECIFICATION FOR COLD-FORMED WELDED AND SEAMLESS CARBON STEEL STRUCTURAL TUBING IN ROUNDS AND SHAPES ASTM A500.
- STANDARD SPECIFICATION FOR ELECTRIC-RESISTANCE-WELDED CARBON AND ALLOY STEEL MECHANICAL TUBING ASTM A513.
- STANDARD SPECIFICATION FOR SEAMLESS CARBON AND ALLOY STEEL MECHANICAL TUBING ASTM A519.
- STANDARD SPECIFICATION FOR SPECIAL QUALITY HOT-ROLLED CARBON STEEL BARS ASTM A576.
- STANDARD SPECIFICATION FOR STEEL, CARBON, STRIP, COLD-ROLLED SPRING QUALITY GENERAL REQUIREMENTS ASTM A682.
- AISI - AMERICAN IRON AND STEEL INSTITUTE.

TEK STANDARDS PERTAINING TO MATERIALS

062-1702-00	Welding, Soldering & Brazing	D-100	Die Casting & Molding Standards
062-1703-00	Finishes, Glossary of Terms		
062-1713-00	Drafting, Aluminum Extrusions	H Series	Tooling Standards
062-1718-00	Finish Quality, Cosmetic		
062-2845-00	Mechanically Applied Finishes		
062-2848-00	Bend Allowance & Deduction	062-5818-01	Aluminum (M-150)
062-2850-00	Finish, Surface Texture	M-200	Brass
062-2854-00	Finishes, Chemical & Electromechanical	M-250	Copper
062-2856-00	Non-Additive Finishes for Brass, Copper & Copper Alloys	M-300	Copper-Beryllium
062-2860-00	Finishes, Anodized	M-350	Beryllium-Nickel
062-2863-00	Zinc Die Cast Finishes, Chromate Conversion Coatings	M-400	Phosphor-Bronze
062-2868-00	Finish, Etch Chromate & Lacquer (On Aluminum)	M-450	Steel
062-2868-01	Chromate Conversion Coating for Al Die Casting Alloy 3431	M-500	Stainless Steel
062-2871-00	Finish, Passivating	M-550	Magnetic Shielding Materials (Iron-Nickel & Nickel-Silver)
062-5818-00	General Information about Bulk Raw Materials	M-600	Copper-Nickel-Zinc

STEEL (CONT)

WIRE

SIZE*	TYPE†	SPECIFICATION†	TEMPER	FINISH	PART NUMBER	CC
.010 x .400 .015 x .188 .020 x .750 .020 dia .020 dia x 2.750 long	1010/1012 Spring	A109 A109	Soft Temper Rockwell 46-48 Music Wire Music Wire	Cold Rolled CRS Cold Rolled	251-0998-00 251-0541-00 251-0966-00 251-3053-00 251-3053-01	L 1b J+ 1b J- 1b M+ 1b E- ea
.040 x .400 .041 dia (18 guage) .050 x .250 .060 x .625 .062 dia	1050 1095 1010/1018 1095	A109 ASTM A228 A109 ASTM A109 AISI	Annealed Spring Spring (Music) Annealed Spring Annealed Key Stock	Cold Rolled, Mill Finish	251-0780-00 251-0837-00 251-0678-01 251-0528-04 251-0932-00	I+ 1b J+ 1b J- 1b J 1b G+ ft
.093 sq x 3 ft .093 dia .109 x .375 .125 dia .125 dia	1095 12L15/AISI Invar "36" Ledloy A	AISI ASTM A510 Carpenter AISI	Key Stock Cold Drawn Annealed	Smooth Down Cold Finish Cold Rolled, Bright Finish Cold Drawn Cold Finish	251-0920-00 251-0690-00 251-0668-00 251-0814-00 251-0559-00	I+ ft I ft G 1b K 1b I 1b
.156 dia .187 sq .188 dia .188 dia .188 hex	Ledloy 1095 Laled/Ledloy B 1018 12L14	ASTM A108(A29) AISI AISI AISI	Annealed	Cold Finish Smooth Drawn Cold Finish Cold Drawn	251-0741-00 251-0899-00 251-0506-00 251-0983-00 251-0937-00	I+ 1b H+ ft H 1b H- ft I 1b
.250 dia x .185 in long .250 screw stock .250 hex .312 hex .312 dia .312 hex	Laled Ledloy A (300) Ledloy A (300) Laled/Ledloy 6152	AISI ASTM A108(A29) AISI AISI AISI		Bright Basic Cold Drawn Cold Finish Cold Finish Cold Finish	251-0630-00 251-0544-00 251-0748-00 251-0753-00 251-0526-00 251-0759-00	G+ 1b H 1b I 1b I 1b I- 1b H- 1b

BAR

SIZE*	TYPE†	SPECIFICATION†	TEMPER	FINISH	PART NUMBER	CC
.094 x 1.500 x 24. .109 x 1.000 .1196 x 1.750 .125 x .375 .125 x .500 x 144.	1020 1010/1018 1010/1018 1018	ASTM A108(A29) ASTM A109 ASTM A109 ASTM A108(A29)	Half Hard Annealed	Cold Drawn Cold Rolled Cold Rolled Cold Drawn	251-3028-00 251-0726-00 251-0869-01 251-0934-00 251-0985-00	K+ ft H 1b G- 1b I+ 1b I+ 1b
.188 x .375 .250 x .375 .250 x .500 .250 x 1.250 .312 x 2.500 x 18.	1018 1018 1018 1018 01 Alloy	ASTM A108(A29) ASTM A109 ASTM A108(A29) ASTM A108(A29)	Rockwell c 65	Cold Rolled, Plated Cold Rolled Cold Rolled Cold Drawn Cold Worked	251-0618-00 251-0842-00 251-0815-00 251-0935-00 251-3059-00	I+ 1b H+ 1b G+ 1b I 1b N+ ea
.375 dia .375 dia .375 x .500 .437 hex .438 dia	Super Laled A-10 1018 Ledloy 300/Laled 1214 Laled	AISI AISI AISI ASTM A108(A29) AISI	Annealed Annealed Drawn	Cold Drawn Milled Cold Finish	251-0623-00 251-0870-00 251-0936-00 251-0723-00 251-0646-00	H 1b I- ft I 1b I- 1b H+ 1b
.500 dia .500 hex .500 sq .750 dia .750 hex	Laled Ledloy 1018 Ledloy Ledloy A (300)	AISI AISI ASTM A108(A29) AISI AISI	Annealed	Cold Drawn Cold Finish Cold Drawn Cold Finish Cold Finish	251-0533-00 251-0599-00 251-0891-00 251-0601-00 251-0676-00	H 1b H+ 1b H+ 1b H+ 1b H- ft
1.000 x 1.500 1.062 dia 1.187 dia 1.625 dia 1.875 dia	1018 Laled/Ledloy 300 Ledloy 1018 Ledloy A (300)	ASTM A108(A29) AISI ASTM A108(A29) ASTM A108(A29)	As Drawn	Cold Drawn Cold Finish Cold Finish Cold Finish Cold Finish	251-3004-00 251-0681-00 251-0667-00 251-0877-00 251-0928-00	H 1b H+ ft H+ 1b H 1b H 1b

STRIP

SIZE*	TYPE†	SPECIFICATION†	TEMPER	FINISH	PART NUMBER	CC
.003 x 3.000 Foil .008 x 6.000 .036 x 2.625 .036 x 4.375 .060 x 1.250	1095 1095 1010/1018 1010/1018 1010	SAE SAE ASTM A568 ASTM A568 ASTM A109	Cam. Shtr. Stl. Temp. Clock Spring Annealed Annealed Annealed	Polished Bright Bright #1 or 2	251-0784-00 251-0925-00 251-0619-02 251-0619-03 251-0528-03	N+ 1b N 1b G+ 1b G+ 1b I+ 1b
.060 x 3.500 .062 x 1.250 .083 x 1.625 .090 x 1.875 .090 x 3.250	1010 1074 1010 1010/1018 1010	ASTM A366 (A568) AISI ASTM A109 ASTM A388 & A568 ASTM A109	Cold Rolled Spring Full Hard, Spring Skin Rolled	Dull Cold Rolled Cold Rolled Cold Rolled	251-0528-02 251-0865-00 251-0866-00 251-0975-00 251-0910-00	G 1b J- 1b I+ 1b G 1b H- 1b

14

STEEL (CONT)

SHEET

SIZE*	TYPE†	SPECIFICATION‡	TEMPER	FINISH	PART NUMBER	CC
.011 x 24 x 39.5	305	ASTM A366 (A568)	Annealed	#1 Finish, Tin Plated	251-0664-00	H 1b
.015 x 36 x 120	1010/1018	ASTM A366 (A568)	Annealed	Cold Rolled	251-0543-00	G 1b
.024 x 36 x 120	1010/1018	ASTM A366 (A568)	Annealed	Cold Rolled	251-0503-00	G+ 1b
.030 x 48 x 120	1010/1018	ASTM A366 (A568)	Annealed	Cold Rolled	251-0529-00	G 1b
.036 x 36 x 120	1010/1018	AISI	Annealed	Cold Rolled	251-0619-00	F+ 1b
.048 x 36 x 120	1010/1018	ASTM A366 (A568)	Annealed	Cold Rolled	251-0540-00	G 1b
.048 x 48 x 144	1010/1018	ASTM A366 (A568)	Annealed	Cold Rolled	251-0540-01	G 1b
.050 x 23.938	1095	AISI	Annealed Spring	Cold Rolled	251-0678-00	J- 1b
.060 x 36 x 120	1010/1018	ASTM A366 (A568)	Annealed	Cold Rolled	251-0528-00	G 1b
.083 x 23.937 x 120	1095	ASTM A684 (A568)	Annealed	Bright	251-1000-00	I 1b
.090 x 36 x 120	1010/1018	ASTM A366 (A568)	Annealed	Cold Rolled	251-0620-00	G 1b
.104 x 60 x 120 (12 gauge)	1010/1018	ASTM A366 (A568)	Annealed	Cold Rolled	251-0889-00	G+ 1b
.109 x 20.250	1095	AISI	Annealed	Cold Rolled	251-0677-00	I+ 1b
.125 x 48 x 144	1010/1018	ASTM A366 (A568)	Annealed	Bright Surface Both Sides	251-3055-00	I+ 1b
.1196 x 48 x 120	1018	ASTM A366 (A568)	Annealed	Cold Rolled	251-0869-00	G 1b

TUBE

SIZE*	TYPE†	SPECIFICATION‡	TEMPER	FINISH	PART NUMBER	CC
.094 OD x .049 ID	1015		Quarter Hard	Mill Finish	251-0557-00	G- ft
.437 OD x .035 wall	4130	ASTM A519	Annealed	Cold Drawn	251-0697-00	J ft
.750 x 1.500 Rectangle x .083 wall	MT1010	ASTM A513			251-0929-00	H- ft
1.000 sq x .065 wall		ASTM A500	As Drawn	Suitable for Plating	251-0834-00	G ft
1.000 x 2.000 Rectangle x .054 wall	1010	ASTM A513			251-3002-00	I+ ft
1.250 OD x .156 wall	1010/108	ASTM A513		Cold Drawn	251-0913-00	K ft

ROD, PINION

PITCH	TEETH	PITCH DIAMETER	PART NUMBER	CC
64	12	.118	251-0698-00	J ft
64	16	.250	251-0800-00	I+ ft
64	15	.234	251-0811-00	K- ft
48	20	.417	251-0887-00	K- ft

MESH

DESCRIPTION	PART NUMBER	CC
.063 sq Tin/Copper Plate Steel	258-0469-00	F- ft
.063 x 1.100 ft long Tin/Copper Plate Steel	258-0469-02	
.063 x 1.600 ft long Tin/Copper Plate Steel	258-0469-01	
.094 dia Tin/Copper Plate Steel	258-0481-00	F+ ft
25 inch Mesh, 30. x 150. rolls	251-0530-00	A- si

MISC.

DESCRIPTION	PART NUMBER	CC
Orametal Perfex, 40% Open, #22 Gauge (36 x 120)	251-0516-00	A+ si
Strapping .023 x .750, Electro Galvanized	251-0590-00	C ft

CONTINUOUS THREAD

DESCRIPTION (THREAD SIZE)	PART NUMBER	CC
6-32 Steel, Cold Plate	251-0971-00	G+ ft
.750-5 Acme LH	251-0912-00	M ft
.750-5 Acme LH	251-0556-00	G+ 1b

CONDUIT

DESCRIPTION	PART NUMBER	CC
.500 Dia Cold Rolled Galvanized Steel, .025 Wall	251-3034-00	G- ft
1 x 10 ft Liquid Tight Steel Tube	251-3035-00	H+ ft

STEEL (006 NUMBERS) ANGLES

SIZE	PART NUMBER	CC
.125 x 1.000 x 1.000 x 240	006-2622-00	K+ ea
.125 x 1.500 x 1.500 x 240	006-2623-00	M- ea
.125 x 2.000 x 2.000 x 240	006-2624-00	M ea
.187 x 1.250 x 1.250 x 240	006-2626-00	M- ea
.187 x 1.500 x 1.500 x 240	006-2627-00	M ea
.187 x 2.000 x 2.000 x 240	006-2628-00	M+ ea
.250 x 1.000 x 1.000 x 240	006-2630-00	M ea
.250 x 1.500 x 1.500 x 240	006-2631-00	N- ea
.250 x 2.500 x 2.500 x 240	006-2632-00	N+ ea
.250 x 3.000 x 3.000 x 240	006-2633-00	O ea

BAR

SIZE	PART NUMBER	CC
.125 x .750 x 240	006-2697-00	K- ea
.125 x 1.000 x 240	006-2634-00	K ea
.125 x 2.000 x 240	006-2636-00	L ea
.187 x 1.000 x 240	006-2637-00	K+ ea
.250 x 1.000 x 240	006-2638-00	L ea
.250 x 1.500 x 240	006-2639-00	M ea
.250 x 2.000 x 240	006-2640-00	M ea
.250 x 3.000 x 240	006-2641-00	N- ea
.375 x 3.000 x 240	006-2645-00	N+ ea

NOTES

§§ STATUS CODES

CR	Current Production
EN	Engineering
PP	Pre-Production
CS	Customer Service
NP	Non-Production
DL	Deleted
OB	Obsolete Instrument
CM	Custom Mod Instrument
DS	Digital Systems
OT	Obsolescent Instrument
MP	Modified Part
LR	Last Supply Current
LS	Last Supply Customer Service
VN	Vendor
TC	Tequipment Current Production
IN	International
SC	Sony/Tek Current Production

THE STATUS IN THIS CATALOG WAS CORRECT AT THE TIME IT WAS PUBLISHED, BUT IT IS SUBJECT TO CHANGE.

§ TO USE A PART WITH THIS STATUS ON A NEW INSTRUMENT REQUIRES THAT A NEW PURCHASED PART INITIATION FORM (PPIF) BE INITIATED.

(A GLOSSARY OF TERMS FOR THESE STATUS CODES CAN BE FOUND ON PAGE 0-10).

COST CODE

(CC COLUMN)

CODE	≈ VALUE with -	≈ VALUE no suffix	≈ VALUE with +
A	.2¢	.5¢	.75¢
B	1.25¢	1.5¢	2¢
C	2.5¢	3¢	3.75¢
D	4.25¢	5¢	6¢
E	7¢	8¢	10¢
F	13¢	15¢	18¢
G	22¢	25¢	35¢
H	40¢	50¢	60¢
I	65¢	75¢	\$1
J	\$1.25	\$1.50	\$2
K	\$2.50	\$3	\$3.75
L	\$4.25	\$5	\$6
M	\$7	\$8	\$10
N	\$13	\$15	\$18
O	\$22	\$25	\$35+

NOTE: Costs may vary from order to order due to order quantities, vendor, etc.

CROSS REFERENCE INDEX

STEEL

PART NUMBER	DESCRIPTION	SIZE	PAGE NO.	STATUS§§	PART NUMBER	DESCRIPTION	SIZE	PAGE NO.	STATUS§§
006-2621-00	Angle	.125 x .750		DL	251-0698-00	Rod Pinion	64 pitch	14-3	CR
006-2622-00	Angle	.125 x 1.000	14-3	CR	251-0723-00	Bar	.437 hex	14-2	CR
006-2623-00	Angle	.125 x 1.500	14-3	CR	251-0726-00	Bar	.109 x 1.000	14-2	CR
006-2624-00	Angle	.125 x 2.000	14-3	CR	251-0734-00	Wire	.026 dia		DL
006-2625-00	Angle	.187 x 1.000		DL	251-0741-00	Wire	.156 dia	14-2	CR
006-2626-00	Angle	.187 x 1.250	14-3	CR	251-0748-00	Wire	.250 hex	14-2	CR
006-2627-00	Angle	.187 x 1.500	14-3	CR	251-0749-00	Strip	.012 x 1.000		CS
006-2628-00	Angle	.187 x 2.000	14-3	CR	251-0753-00	Wire	.312 hex	14-2	CR
006-2629-00	Angle	.187 x 3.000		DL	251-0759-00	Wire	.312 hex	14-2	CS
006-2630-00	Angle	.250 x 1.000	14-3	CR	251-0767-00	Wire	.059 x .186		DL
006-2631-00	Angle	.250 x 1.500	14-3	CR	251-0780-00	Strip	.040 x .400	14-2	CR
006-2632-00	Angle	.250 x 2.500	14-3	CR	251-0784-00	Strip	.003 x 3.000	14-2	CR
006-2633-00	Angle	.250 x 3.000	14-3	CR	251-0800-00	Rod Pinion	64 pitch	14-3	OB
006-2634-00	Bar	.125 x 1.000	14-3	CR	251-0811-00	Rod Pinion	64 pitch	14-3	CR
006-2635-00	Bar	.125 x 1.500		DL	251-0814-00	Wire	.125 dia	14-2	CS
006-2636-00	Bar	.125 x 2.000	14-3	CR	251-0815-00	Bar	.250 x .500	14-2	CS
006-2637-00	Bar	.187 x 1.000	14-3	CR	251-0834-00	Tube	1.000 sq	14-3	CR
006-2638-00	Bar	.250 x 1.000	14-3	CR	251-0837-00	Wire	.041 dia	14-2	CR
006-2639-00	Bar	.250 x 1.500	14-3	CR	251-0842-00	Bar	.250 x .375	14-2	CR
006-2640-00	Bar	.250 x 2.000	14-3	CR	251-0851-00	Wire	.022 dia		DL
006-2641-00	Bar	.250 x 3.000	14-3	CR	251-0865-00	Strip	.062 x 1.250	14-2	CS
006-2642-00	Bar	.375 x 1.000		DL	251-0866-00	Strip	.083 x 1.625	14-2	CS
006-2643-00	Bar	.375 x 1.500		DL	251-0869-00	Sheet	.1196 x 36 x 96	14-3	CR
006-2644-00	Bar	.375 x 2.000		DL	251-0869-01	Bar	.1196 x 1.750	14-2	CR
006-2645-00	Bar	.375 x 3.000	14-3	CR	251-0870-00	Bar	.375 dia	14-2	CS
006-2646-00	Bar	.375 dia x 240		DL	251-0871-00	Bar	1.000 dia		DL
006-2647-00	Bar	.500 dia x 240		DL	251-0877-00	Bar	1.625 dia	14-2	CR
006-2648-00	Bar	.750 dia x 240		DL	251-0884-00	Bar	.250 x .500		DL
006-2649-00	Angle	.250 x 2.000		DL	251-0885-00	Bar	.500 dia		DL
006-2697-00	Bar	.125 x .750	14-3	CR	251-0887-00	Rod Pinion	48 pitch	14-3	CR
251-0503-00	Sheet	.024 x 36 x 120	14-3	CR	251-0889-00	Sheet	.104 x 60 x 120	14-3	CR
251-0504-00	Sheet	.025 x 36 x 120		DL	251-0891-00	Bar	.500 sq	14-2	CR
251-0506-00	Wire	.188 dia	14-2	CR	251-0895-00	Wire	.203 dia		DL
251-0516-00	Misc		14-3	CS	251-0899-00	Wire	.187 sq	14-2	CR
251-0526-00	Wire	.312 dia	14-2	CR	251-0910-00	Strip	.090 x 3.250	14-2	CR
251-0528-00	Sheet	.060 x 36 x 120	14-3	CR	251-0911-00	Wire	.060 x .500		DL
251-0528-01	Strip	.060 x 3.875		DL	251-0912-00	Bar, Thread	.750-5	14-3	CR
251-0528-02	Strip	.060 x 3.500	14-2	CR	251-0913-00	Tube	.125 OD	14-3	CR
251-0528-03	Strip	.060 x 1.250	14-2	CR	251-0920-00	Wire	.093 sq key stock	14-2	CR
251-0528-04	Sheet	.060 x .625	14-2	CR	251-0921-00	Wire	.040 dia		DL
251-0529-00	Sheet	.030 x 48 x 120	14-3	CR	251-0924-00	Bar	1.000 x 2.000 dia		DL
251-0530-00	Mesh	25 in.	14-3	CS	251-0925-00	Strip	.008 x 6.000	14-2	CR
251-0533-00	Bar	.500 dia	14-2	CR	251-0928-00	Bar	1.875 dia	14-2	CR
251-0540-00	Sheet	.048 x 36 x 120	14-3	CR	251-0929-00	Tube	.750 x 1.500	14-3	PP
251-0540-01	Sheet	.048 x 48 x 144	14-3	CR	251-0931-00	Wire	.062 sq x 3 ft		NP
251-0541-00	Strip	.015 x .188	14-2	CR	251-0932-00	Wire	.062 dia	14-2	CR
251-0543-00	Sheet	.015 x 36 x 120	14-3	CR	251-0934-00	Bar	.125 x .375	14-2	PP
251-0544-00	Wire	.250 screw stock	14-2	CR	251-0935-00	Bar	.250 x 1.250	14-2	CR
251-0556-00	Bar, Thread	.750-5	14-3	CR	251-0936-00	Bar	.375 x .500	14-2	CR
251-0557-00	Tube	.090 x .049 ID	14-3	CS	251-0937-00	Wire	.188 hex	14-2	CR
251-0559-00	Wire	.125 dia	14-2	CR	251-0966-00	Strip	.020 x .750	14-2	CR
251-0589-00	Wire	.015 x .375		DL	251-0971-00	Bar, Thread	6-32	14-3	CS
251-0590-00	Misc.		14-3	CS	251-0975-00	Strip	.090 x 1.875	14-2	CS
251-0599-00	Bar	.500 hex	14-2	CR	251-0983-00	Wire	.188 dia	14-2	CR
251-0601-00	Bar	.750 dia	14-2	CR	251-0985-00	Bar	.125 x .500	14-2	CR
251-0618-00	Bar	.188 x .375	14-2	CR	251-0986-00	Bar	.125 x .875		DL
251-0619-00	Sheet	.036 x 36 x 120	14-3	CR	251-0998-00	Bar	.010 x .400	14-2	CR
251-0619-02	Strip	.036 x 2.625	14-2	CR	251-1000-00	Sheet	.083 x 23.937	14-3	CR
251-0619-03	Strip	.036 x 4.375	14-2	CR	251-3002-00	Tube	1.000 x 2.000 x .054	14-3	CR
251-0620-00	Sheet	.090 x 36 x 120	14-3	CR	251-3004-00	Bar	1.000 x 1.500	14-2	CR
251-0620-01	Strip	.090 x 2.700		DL	251-3017-00	Strip	.032 x 1.250 x 84		DL
251-0622-00	Wire	.188 dia		CS	251-3027-00	Tube	1.500 x 2.500 x .065		DL
251-0623-00	Bar	.375 dia	14-2	CR	251-3028-00	Bar	.0937 x 1.500	14-2	CR
251-0630-00	Wire	.250 x .185	14-2	OB	251-3034-00	Conduit	.500 dia	14-3	CR
251-0646-00	Bar	.438 dia	14-2	CR	251-3035-00	Conduit	1.000 x 10 ft	14-3	PP
251-0664-00	Sheet	.011 x 24 x 39.500	14-3	CR	251-3051-00	Sheet	.074 x 36 x 120		DL
251-0667-00	Bar	1.187 dia	14-2	CS	251-3053-00	Wire	.020 dia	14-2	CR
251-0668-00	Bar	.109 x .375	14-2	CS	251-3053-01	Wire	.020 dia x 2.750	14-2	CR
251-0676-00	Bar	.750 hex	14-2	CS	251-3055-00	Sheet	.125 x 48 x 144	14-3	PP
251-0677-00	Sheet	.109 x 20.250	14-3	CR	251-3059-00	Bar	.312 x 2.500 x 18	14-2	PP
251-0678-00	Sheet	.050 x 23.938	14-3	CR	258-0469-00	Mesh	.063 sq	14-3	CR
251-0678-01	Strip	.050 x .250	14-2	CR	258-0469-01	Mesh	.063 x 1.600	14-3	CR
251-0681-00	Bar	1.062 dia	14-2	CR	258-0469-02	Mesh	.063 x 1.100	14-3	CR
251-0690-00	Wire	.093 dia	14-2	CR	258-0481-00	Mesh	.094 dia	14-3	CR
251-0697-00	Tube	.437 OD	14-3	CR	258-0527-00	Wire	.020 dia		DL

STEEL (CONT)

• APPROXIMATE MECHANICAL PROPERTIES FOR VARIOUS TEMPER OF COLD-ROLLED CARBON STRIP

NOTE: These values are given as information only and are not intended as criteria for acceptance or rejection.

TEMPER	TENSILE STRENGTH psi	ELONGATION IN 2 IN. FOR 0.050 IN. THICKNESS OF STRIP %	REMARKS
No. 1 (Hard)	90.000 ± 10.000		A very stiff, cold-rolled strip intended for flat blanking only, and not requiring ability to withstand cold forming.
No. 2 (Half-Hard)	65.000 ± 10.000	10 ± 6	A moderately stiff cold-rolled strip intended for limited bending.
No. 3 (Quarter-Hard)	55.000 ± 10.000	20 ± 7	A medium soft cold-rolled strip intended for limited bending, shallow drawing and stamping.
No. 4 (Skin-Rolled)	48.000 ± 10.000	32 ± 8	A soft ductile cold-rolled strip intended for deep drawing where no surface strain or fluting is permissible.
No. 5 (Dead-Soft)	44.000 ± 6.000	39 ± 6	A soft ductile cold-rolled strip intended for deep drawing where stretcher strains or fluting are permissible. Also for extrusions.

SHEET GAUGES

THICKNESS (INCH)	STANDARD GAUGE NUMBER
.2391	3
.2242	4
.2092	5
.1943	6
.1793	7
.1644	8
.1495	9
.1345	10
.1196	11
.1046	12
.0897	13
.0747	14
.0673	15
.0598	16
.0538	17
.0478	18
.0418	19
.0359	20
.0329	21
.0299	22
.0269	23
.0239	24
.0209	25
.0179	26
.0164	27
.0149	28
.0135	29
.0120	30
.0105	31
.0097	32
.0090	33
.0082	34
.0075	35
.0067	36
.0064	37
.0060	38

WIRE GAUGES

THICKNESS (INCH)	U.S. STEEL GAUGE NUMBER
.2830	1
.2625	2
.2437	3
.2253	4
.2070	5
.1920	6
.1770	7
.1620	8
.1483	9
.1350	10
.1205	11
.1055	12
.0915	13
.0800	14
.0720	15
.0625	16
.0540	17
.0475	18
.0410	19
.0348	20
.0317	21
.0286	22
.0258	23
.0230	24
.0204	25
.0181	26
.0173	27
.0162	28
.0150	29
.0140	30
.0132	31
.0128	32
.0118	33
.0104	34
.0095	35
.0090	36
.0085	37
.0080	38
.0075	39
.0070	40
.0066	41
.0062	42
.0060	43
.0058	44
.0055	45
.0052	46
.0050	47
.0048	48
.0046	49
.0044	50

STEEL (CONT)

THICKNESS TOLERANCES

ASTM A109

SPECIFIED THICKNESS, INCH		THICKNESS TOLERANCES, OVER AND UNDER, INCH				
		SPECIFIED WIDTH, INCHES				
UNDER	TO AND INCL.	UNDER 1 TO 1/2 EXCL.	UNDER 3 TO 1 INCL.	3 TO 6 INCL.	OVER 6 TO 9 INCL.	OVER 9 TO 12 INCL.
.250	.200	.003	.004	.0045	.0045	.005
.200	.161	.0025	.0035	.004	.004	.0045
.161	.100	.002	.002	.003	.003	.003
.100	.069	.002	.002	.0025	.003	.003
.069	.050	.002	.002	.0025	.0025	.0025
.050	.040	.002	.002	.0025	.0025	.0025
.040	.035	.002	.002	.002	.002	.002
.035	.032	.0015	.0015	.002	.002	.002
.032	.029	.0015	.0015	.0015	.002	.002
.029	.026	.001	.0015	.0015	.002	.002
.026	.023	.001	.001	.001	.0015	.0015
.023	.020	.001	.001	.001	.0015	.0015
.020	.013	.00075	.00075	.00075	.001	.001
.013	.009	.00075	.00075	.00075	.001	.001
.009	.007	.00075	.00075	.00075	.001	.001
.007		.0005	.0005	.0005		

MEASURED 3/8 inch or more in from the edge on 1 inch or wider; and on narrower than 1 inch at any place between the edges.

ASTM A568

SPECIFIED WIDTH, INCHES	THICKNESS TOLERANCES OVER, INCH NO TOLERANCE UNDER					
	SPECIFIED MINIMUM THICKNESS, INCH					
	OVER .098 TO .142 INCL.	OVER .071 TO .098 INCL.	OVER .057 TO .071 INCL.	OVER .039 TO .057 INCL.	OVER .019 TO .039 INCL.	OVER .014 TO .019 INCL.
OVER 12 TO 15 INCL.	.010	.010	.010	.008	.006	.004
OVER 15 TO 72 INCL.	.012	.010	.010	.008	.006	.004
OVER 72	.014	.012	.010	.008	.006	

Note 1. Thickness is measured at any point across the width not less than 3/8 inch from a side edge.
 Note 2. The specified thickness range captions noted above also apply when sheet is specified to a nominal thickness, and the above tolerances are divided equally over and under (based upon ASTM A568).

ASTM A229

DIAMETER, IN. (MM)	PERMISSIBLE VARIATIONS, PLUS AND MINUS, IN. (MM)	PERMISSIBLE OUT-OF-ROUND, IN. (MM)
.020 to .028 (.51 to .71), incl.	.0008 (.02)	.0008 (.02)
Over .028 to .075 (.71 to 1.90), incl.	.001 (.03)	.001 (.03)
Over .075 to .375 (1.90 to 9.52), incl.	.002 (.05)	.002 (.05)
Over .375 to .625 (9.52 to 15.88), incl.	.003 (.08)	.003 (.08)

ASTM A228

DIAMETER, IN.	PERMISSIBLE VARIATIONS, PLUS AND MINUS, IN.	PERMISSIBLE OUT-OF-ROUND, IN.
.004 to .010, incl.	.0002	.0002
Over .010 to .028, incl.	.0003	.0003
Over .028 to .063, incl.	.0004	.0004
Over .063 to .080, incl.	.0005	.0005
Over .080 to .250, incl.	.001	.001

PER AISI

DIAMETER, IN.	DIAMETER TOLERANCE, IN., PLUS AND MINUS	OUT-OF-ROUND TOLERANCE, IN.
.035 to .075, incl.	.001	.001
Over .075 to .148, incl.	.0015	.0015
Over .148 to .500, incl.	.002	.002
Over .500 to .625, incl.	.0025	.0025
Over .625	.003	.003

STEEL (CONT)

THICKNESS TOLERANCES

ASTM A510

SIZES OF WIRE RODS ¹			
INCH FRACTION	DECIMAL EQUIVALENT, IN	INCH FRACTION	DECIMAL EQUIVALENT, IN
7/32	0.219	31/64	0.484
15/64	0.234	1/2	0.500
1/4	0.250	33/64	0.516
17/64	0.266	17/32	0.531
9/32	0.281	35/64	0.547
19/64	0.297	9/16	0.562
5/16	0.312	37/64	0.578
21/64	0.328	19/32	0.594
11/32	0.344	39/64	0.609
23/64	0.359	5/8	0.625
3/8	0.375	41/64	0.641
25/64	0.391	21/32	0.656
13/32	0.406	43/64	0.672
27/64	0.422	11/16	0.688
7/16	0.438	45/64	0.703
29/64	0.453	23/32	0.719
15/32	0.469	47/64	0.734

¹ ROUNDED OFF TO 3 DECIMAL PLACES IN DECIMAL EQUIVALENTS ACCORDING TO PROCEDURES OUTLINED IN RECOMMENDED PRACTICE E29.

PERMISSIBLE VARIATIONS IN DIAMETER FOR UNCOATED COARSE ROUND WIRE		
IN COILS		
DIAMETER OF WIRE, IN.	PERMISSIBLE VARIATIONS, PLUS & MINUS, IN.	PERMISSIBLE OUT-OF-ROUND, IN.
0.035 to under 0.076	0.001	0.001
0.076 to under 0.500	0.002	0.002
0.500 and over	0.003	0.003
STRAIGHTENED AND CUT		
DIAMETER OF WIRE, IN.	PERMISSIBLE VARIATIONS, PLUS & MINUS, IN.	PERMISSIBLE OUT-OF-ROUND, IN.
0.035 to under 0.076	0.001	0.001
0.076 to 0.148, incl.	0.002	0.002
Over 0.148 to under 0.500	0.003	0.003
0.500 and over	0.004	0.004

PERMISSIBLE VARIATIONS IN DIAMETER FOR WIRE ROD IN COILS			
DIAMETER OF ROD		PERMISSIBLE VARIATION, PLUS & MINUS, IN.	PERMISSIBLE OUT-OF-ROUND, IN.
FRACTION	DECIMAL		
7/32 to 47/64 IN, INCL.	0.219 to 1.734 IN, INCL.	0.016	0.025

PERMISSIBLE VARIATIONS IN LENGTH FOR STRAIGHTENED AND CUT WIRE	
CUT LENGTH, FT.	PERMISSIBLE VARIATIONS, PLUS & MINUS, IN.
Under 3	1/16
3 to 12, incl.	3/32
Over 12	1/8

PERMISSIBLE VARIATIONS FOR BURRS FOR STRAIGHTENED AND CUT WIRE	
DIAMETER OF WIRE, IN.	PERMISSIBLE VARIATION OVER MEASURED DIAMETER, IN.
Up to 0.125, incl.	0.004
Over 0.125 to 0.250, incl.	0.006
Over 0.250 to 0.500, incl.	0.008
Over 0.500.	0.100

NOTE: FOR PURPOSES OF DETERMINING CONFORMANCE WITH THIS SPECIFICATION, ALL SPECIFIED LIMITS ARE ABSOLUTE AS DEFINED IN RECOMMENDED PRACTICE E29.

STEEL(CONT)

THICKNESS TOLERANCES PER ASTM A29

TABLE 7 Permissible Variations in Cross Section for Hot-Rolled Round, Square, and Round-Cornered Square Bars of Carbon Steel

Specified Size, in. ^A	Permissible Variation from Specified Size, in. ^A		Out-of-Round or Out-of-Square, in. ^{A,B}
	Over	Under	
To 3/16, incl	0.005	0.005	0.008
Over 3/16 to 7/16, incl	0.006	0.006	0.009
Over 7/16 to 3/8, incl	0.007	0.007	0.010
Over 3/8 to 7/8, incl	0.008	0.008	0.012
Over 7/8 to 1, incl	0.009	0.009	0.013
Over 1 to 1 1/8, incl	0.010	0.010	0.015
Over 1 1/8 to 1 1/4, incl	0.011	0.011	0.016
Over 1 1/4 to 1 3/8, incl	0.012	0.012	0.018
Over 1 3/8 to 1 1/2, incl	0.014	0.014	0.021
Over 1 1/2 to 2, incl	1/64	1/64	0.023
Over 2 to 2 1/2, incl	1/32	0	0.023
Over 2 1/2 to 3 1/2, incl	3/64	0	0.035
Over 3 1/2 to 4 1/2, incl	1/16	0	0.046
Over 4 1/2 to 5 1/2, incl	3/64	0	0.058
Over 5 1/2 to 6 1/2, incl	1/8	0	0.070
Over 6 1/2 to 8 1/4, incl	5/32	0	0.085
Over 8 1/4 to 9 1/2, incl	3/16	0	0.100
Over 9 1/2 to 10, incl	1/4	0	0.120

^A 1 in. = 25.4 mm.

^B Out-of-round is the difference between the maximum and minimum diameters of the bar, measured at the same cross section. Out-of-square is the difference in the two dimensions at the same cross section of a square bar between opposite faces.

TABLE 8 Permissible Variations in Cross Section for Hot-Rolled Hexagonal Bars of Carbon Steel

Specified Sizes Between Opposite Sides, in. ^A	Permissible Variations from Specified Size, in. ^A		Out-of-Hexagon (Carbon Steel and Alloy Steel) or Out-of-Octagon (Alloy Steel), in. ^{A,B}
	Over	Under	
To 1/2, incl	0.007	0.007	0.011
Over 1/2 to 1, incl	0.010	0.010	0.015
Over 1 to 1 1/2, incl	0.021	0.013	0.025
Over 1 1/2 to 2, incl	1/32	1/64	1/32
Over 2 to 2 1/2, incl	3/64	1/64	3/64
Over 2 1/2 to 3 1/2, incl	1/16	1/64	1/16

^A 1 in. = 25.4 mm.

^B Out-of-hexagon or out-of-octagon is the greatest difference between any two dimensions at the same cross section between opposite faces.

TABLE 9 Permissible Variations in Thickness and Width for Hot-Rolled Square Edge and Round Edge Flat Bars of Carbon Steel

Specified Width, in. ^A	Permissible Variations in Thickness, for Thickness Given, Over and Under, in. ^A						Permissible Variations in Width, in. ^A		
	0.203 to 0.230, excl	0.230 to 1/4, excl	1/4 to 1/2, incl	Over 1/2 to 1, incl	Over 1 to 2, incl	Over 2 to 3, incl	Over 3	Over	Under
To 1, incl	0.007	0.007	0.008	0.010	1/64	1/64
Over 1 to 2, incl	0.007	0.007	0.012	0.015	1/32	1/32	1/32
Over 2 to 4, incl	0.008	0.008	0.015	0.020	1/32	3/64	3/64	1/16	1/32
Over 4 to 6, incl	0.009	0.009	0.015	0.020	1/32	3/64	3/64	1/16	1/16
Over 6 to 8, incl	^B	0.015	0.016	0.025	1/32	3/64	^C	1/8 ^C	3/32 ^C

^A 1 in. = 25.4 mm.

^B Flats over 6 to 8 in. (162 to 203 mm), incl, in width, are not available as hot rolled carbon steel bars in thickness under 0.230 in. (0.584 mm).

^C On flats over 6 to 8 in., incl, in width and over 3 in. (76 mm) in thickness, tolerances shall be negotiated with the manufacturer.

TABLE 10 Permissible Variations in Thickness, Length, and Out-of-Square for Hot-Rolled Bar Size Angles of Carbon Steel

Specified Length of Leg, in. ^{A,B}	Permissible Variations in Thickness, for Thicknesses Given, Over and Under, in. ^A			Permissible Variations for Length of Leg, Over and Under, in. ^A
	To 3/16, incl	Over 3/16 to 3/8, incl	Over 3/8	
To 1, incl	0.008	0.010	...	1/32
Over 1 to 2, incl	0.010	0.010	0.012	3/64
Over 2 to 3, excl	0.012	0.015	0.015	1/16

^A 1 in. = 25.4 mm.

^B The longer leg of an unequal angle determines the size for tolerance. The out-of-square tolerance in either direction is 1 1/2 deg (0.03 rad).

TABLE 11 Permissible Variations in Dimensions for Hot-Rolled Bar Size Channels of Carbon Steel

Specified Size of Channel, in. ^A	Permissible Variations in Size, Over and Under, in. ^A				Out-of-Square of Either Flange, in./in. of Flange Width ^{A,C}
	Depth of Section ^{A,B}	Width of Flanges ^{A,B}	Thickness of Web for Thickness Given		
To 1/16, incl			Over 1/16		
To 1 1/2, incl	1/32	1/32	0.010	0.015	1/32
Over 1 1/2 to 3, excl	1/16	1/16	0.015	0.020	1/32

^A 1 in. = 25.4 mm.

^B Measurements for depth of section and width of flanges are over-all.

^C For channels 3/8 in. (15.9 mm) and under in depth, the out-of-square tolerance is 3/64 in./in. (1.2 mm/mm) of depth.

STEEL(CONT)

THICKNESS TOLERANCES

PER ASTM A29

TABLE 12 Permissible Variations in Dimensions for Hot-Rolled Bar Size Tees of Carbon Steel

Specified Size of Tee, in. ^{A,B}	Permissible Variations in Size, in. ^A						
	Width or Depth ^{A,C}		Thickness of Flange		Thickness of Stem		Stem Out-of-Square ^{A,D}
	Over	Under	Over	Under	Over	Under	
To 1¼, incl	¾	¾	0.010	0.010	0.005	0.020	½
Over 1¼ to 2, incl	½	½	0.012	0.012	0.010	0.020	¼
Over 2 to 3, excl	¾	¾	0.015	0.015	0.015	0.020	¾

^A 1 in. = 25.4 mm.

^B The longer member of the unequal tee determines the size for tolerances.

^C Measurements for both width and depth are over-all.

^D Step out-of-square is the variation from its true position of the center line of the stem measured at the point.

TABLE 13 Permissible Variations in Dimensions for Half-Rounds, Ovals, Half-Ovals, and Other Special Bar Size Sections

Due to mill facilities, tolerances on half-rounds, ovals, half-ovals, and other special bar size sections vary among the manufacturers and such tolerances should be negotiated between the manufacturer and the purchaser.

TABLE 14 Permissible Variations in Length for Hot-Rolled Rounds, Squares, Hexagons, Flats, and Bar Size Sections of Carbon Steel

Specified Size of Rounds, Squares, and Hexagons, in. ^A	Specified Size of Flats, in. ^A		Permissible Variations Over Specified Length, in. ^{A,B}				
	Thickness	Width	5 to 10 ft, excl	10 to 20 ft, excl	20 to 30 ft, excl	30 to 40 ft, excl	40 to 60 ft, excl
			Mill Shearing				
To 1, incl	to 1, incl	to 3, incl	½	¾	1¼	1¾	2¼
Over 1 to 2, incl	over 1	to 3, incl	¾	1	1½	2	2½
	to 1, incl	over 3 to 6, incl	¾	1	1½	2	2½
Over 2 to 5, incl	over 1	over 3 to 6, incl	1	1½	1¾	2¼	2¾
Over 5 to 10, incl	2	2½	2¾	3	3¾
	0.230 to 1, incl	over 6 to 8, incl	¾	1¼	1¾	3½	4
	over 1 to 3, incl	over 6 to 8, incl	1¼	1¾	2	3½	4
Bar Size Sections	¾	1	1½	2	2½
	Hot Sawing						
2 to 5, incl	1 and over	3 and over	C	1½	1¾	2¼	2¾
Over 5 to 10, incl	C	2½	2¾	3	3¾

^A 1 in. = 25.4 mm.

^B No permissible variations under.

^C Smaller sizes and shorter lengths are not hot sawed.

TABLE 15 Permissible Variations in Length for Recutting of Carbon Bars Meeting Special Straightness Tolerances

Sizes of Rounds, Squares, Hexagons, Width of Flats and Maximum Dimension of Other Sections, in. ^A	Tolerances for Specified Length, in. ^{A,B}			
	To 12 ft, incl ^C		Over 12 ft ^C	
	Over	Under	Over	Under
To 3, incl	¾	½	¼	¼
Over 3 to 6, incl	¼	¼	¾	¼
Over 6 to 8, incl	¾	¼	½	¼
Rounds over 8 to 10, incl	½	¼	¾	¼

^A 1 in. = 25.4 mm.

^B Tolerances are sometimes required all over or all under the specified length, in which case the sum of the two tolerances applies.

^C 1 ft = 305 mm.

TABLE 16 Permissible Variations in Straightness for Hot Rolled Bars and Bar Size Sections of Carbon Steel^A

Standard tolerances	¼ in. ^B in any 5 ft ^C or (¼ in. × length in ft)/5
Special tolerances	⅛ in. ^B in any 5 ft ^C or (⅛ in. × length in ft)/5

^A Because of warpage, straightness tolerances do not apply to bars if any subsequent heating operation or controlled cooling has been performed.

^B 1 in. = 25.4 mm.

^C 1 ft = 305 mm.

TABLE 17 Permissible Variations in Cross Section for Hot-Rolled Round, Square and Round-Cornered Square Bars of Alloy Steel

Specified Size, in. ^A	Permissible Variation from Specified Size, in. ^A		Out-of-Round or Out-of-Square, in. ^{A,B}
	Over Under		
	Over	Under	
To ¾, incl	0.005	0.005	0.008
Over ¾ to 1, incl	0.006	0.006	0.009
Over 1 to 1¼, incl	0.007	0.007	0.010
Over 1¼ to 1½, incl	0.008	0.008	0.012
Over 1½ to 1¾, incl	0.009	0.009	0.013
Over 1¾ to 2, incl	0.010	0.010	0.015
Over 2 to 2¼, incl	0.011	0.011	0.016
Over 2¼ to 2½, incl	0.012	0.012	0.018
Over 2½ to 3, incl	0.014	0.014	0.021
Over 3 to 3½, incl	¾	¾	0.023
Over 3½ to 4, incl	½	0	0.023
Over 4 to 4½, incl	¾	0	0.035
Over 4½ to 5, incl	¼	0	0.046
Over 5 to 5½, incl	¾	0	0.058
Over 5½ to 6, incl	¾	0	0.070
Over 6 to 6½, incl	¾	0	0.085
Over 6½ to 7, incl	¾	0	0.100
Over 7 to 7½, incl	¾	0	0.100

^A 1 in. = 25.4 mm.

^B Out-of-round is the difference between the maximum and the minimum diameters of the bar, measured at the same cross section. Out-of-square is the difference in the two dimensions at the same cross section of a square bar between opposite faces.

STEEL (CONT)

THICKNESS TOLERANCES PER ASTM A29

TABLE 18 Permissible Variations in Cross Section for Hot-Rolled Hexagonal and Octagonal Bars of Alloy Steel

Specified Sizes Between Opposite Sides, in. ^A	Permissible Variations from Specified Size, in. ^A		Out-of-Hexagon or Out-of-Octagon, in. ^{A,B}
	Over	Under	
To ½, incl	0.007	0.007	0.011
Over ½ to 1, incl	0.010	0.010	0.015
Over 1 to 1½, incl	0.021	0.013	0.025
Over 1½ to 2, incl	⅜	⅜	⅜
Over 2 to 2½, incl	⅜	⅜	⅜
Over 2½ to 3½, incl	⅜	⅜	⅜

^A 1 in. = 25.4 mm.

^B Out-of-hexagon or out-of-octagon is the greatest difference between any two dimensions at the same cross section between opposite faces.

TABLE 19 Permissible Variations in Thickness and Width for Hot-Rolled Square-Edge and Round-Edge Flat Bars of Alloy Steel

Specified Width, in. ^A	Permissible Variations in Thickness, for Thickness Given, Over and Under, in. ^A							Permissible Variations in Width, in. ^A	
	0.203 to 0.230	0.230 to ¼, excl	¼ to ½, incl	Over ½ to 1, incl	Over 1 to 2, incl	Over 2 to 3, incl	Over 3	Over	Under
To 1, incl	0.007	0.007	0.008	0.010	⅜	⅜
Over 1 to 2, incl	0.007	0.007	0.012	0.015	⅜	⅜	⅜
Over 2 to 4, incl	0.008	0.008	0.015	0.020	⅜	⅜	⅜	⅜	⅜
Over 4 to 6, incl	0.009	0.009	0.015	0.020	⅜	⅜	⅜	⅜	⅜
Over 6 to 8, incl	^B	0.015	0.016	0.025	⅜	⅜	^B	⅜ ^B	⅜ ^C

^A 1 in. = 25.4 mm.

^B Flats over 6 to 8 in. (162 to 203 mm), incl, in width, are not available as alloy steel bars in thickness under 0.230 in. (0.584 mm).

^C On flats over 6 to 8 in., incl, in width and over 3 in. (76 mm) in thickness, tolerances shall be negotiated with the manufacturer.

TABLE 20 Permissible Variations in Straightness for Hot-Rolled Bars and Bar Size Sections of Alloy Steel^A

Standard tolerances	¼ in. ^B in any 5 ft ^C or (¼ in. × length in ft)/5
Special tolerances	⅜ in. ^B in any 5 ft ^C or (⅜ in. × length in ft)/5

^A Because of warpage, straightness tolerances do not apply to bars if any subsequent heating operation or controlled cooling has been performed.

^B 1 in. = 25.4 mm.

^C 1 ft = 305 mm.

TABLE 21 Permissible Variations in Length for Hot-Rolled Rounds, Squares, Hexagons, Octagons and Flats of Alloy Steel

Specified Size of Rounds, Squares, Hexagons, Octagons, in. ^A	Tolerance Over Specified Length, in. ^A No Tolerance Under				
	5 to 10 ft, ^B excl	10 to 20 ft, ^B excl	20 to 30 ft, ^B excl	30 to 40 ft, ^B excl	40 to 60 ft, ^B incl
Rounds, Squares, Hexagons, Octagons					
Hot Shearing					
To 1, incl	½	¾	1¼	1¾	2¼
Over 1 to 2, incl	¾	1	1½	2	2½
Over 2 to 5, incl	1	1½	1¾	2¼	2¾
Over 5 to 9½, incl	2	2½	2¾	3	3¼
Hot Sawing					
2 ^C to 5, incl	1½	1½	1¾	2¼	2¾
Over 5 to 9½, incl	1½	2½	2¾	3	3¼
Round-Edge and Square-Edge Flats (Specified Sizes)					
Thickness, in. ^A	Width, in. ^A	Hot Shearing			
		½	¾	1¼	1¾
To 1, incl	to 3, incl	½	¾	1¼	1¾
Over 1	to 3, incl	¾	1	1½	2
To 1, incl	over 3 to 6, incl	¾	1	1½	2
Over 1	over 3 to 6, incl	1	1½	1¾	2¼
To 1, incl	over 6 to 8, incl	¾	1¼	1¾	3½
Over 1 to 3, incl	over 6 to 8, incl	1¼	1¾	2	3½
Hot Sawing					
1 ^C and over	3 ^C and over	1½	1½	1¾	2¼

TABLE 22 Length Tolerances for Special Straightened Alloy Bars Machine Cut on Both Ends

Sizes of Rounds, Squares, Hexagons, Octagons; Widths of Flats and Maximum Dimensions of Other Bar Sections, in. ^A	Tolerance for Specified Length, in. ^B			
	To 12 ft, ^C incl		Over 12 ft ^C	
	Over	Under	Over	Under
To 3, incl	⅜	⅜	¾	⅜
Over 3 to 6, incl	¼	⅜	¾	⅜
Over 6 to 8, incl	¾	⅜	½	⅜
Over 8 to 9½, incl	½	⅜	¾	⅜

^A 1 in. = 25.4 mm.

^B Tolerances are sometimes specified all over or all under the ordered length, in which case the sum of the two tolerances applies.

^C 1 ft = 305 mm.

^A 1 in. = 25.4 mm.

^B 1 ft = 305 mm.

^C Smaller sizes are not hot sawed.

STEEL (CONT)

WEIGHT (OUNCES AND POUNDS PER SQUARE FOOT

Manufacturers' Standard Gage for Steel Sheets: Although the basic weight of steel used in the manufacture of steel plate, bars, and other steel products is 40.8 pounds per square foot per inch of thickness, the Manufacturers' Standard Gage for Steel Sheets is based on a weight of 41.82 pounds per square foot per inch of thickness. This modified figure provides an adjustment for the variation in thickness from the edges to the center of sheets resulting from the rolling process and also for the shearing tolerances which are on the over side. The thicknesses in the table below are based upon this weight of 41.82 pounds and represent standard mill practice. These nominal thicknesses, however, are subject to tolerances or permissible variations as given on page 13-7 for carbon cold-rolled steel.

Standard Gage No.	Ounces Per Square Foot	Pounds Per Square Foot	Equivalent Thickness, Inch
3	160	10.0000	.2391
4	150	9.3750	.2242
5	140	8.7500	.2092
6	130	8.1250	.1943
7	120	7.5000	.1793
8	110	6.8750	.1644
9	100	6.2500	.1495
10	90	5.6250	.1345
11	80	5.0000	.1196
12	70	4.3750	.1046
13	60	3.7500	.0897
14	50	3.1250	.0747
15	45	2.8125	.0673
16	40	2.5000	.0598
17	36	2.2500	.0538
18	32	2.0000	.0478
19	28	1.7500	.0418
20	24	1.5000	.0359
21	22	1.3750	.0329
22	20	1.2500	.0299
23	18	1.1250	.0269
24	16	1.0000	.0239
25	14	.87500	.0209
26	12	.75000	.0179
27	11	.68750	.0164
28	10	.62500	.0149
29	9	.56250	.0135
30	8	.50000	.0120
31	7	.43750	.0105
32	6.5	.40625	.0097
33	6	.37500	.0090
34	5.5	.34375	.0082
35	5	.31250	.0075
36	4.5	.28125	.0067
37	4.25	.26562	.0064
38	4	.25000	.0060

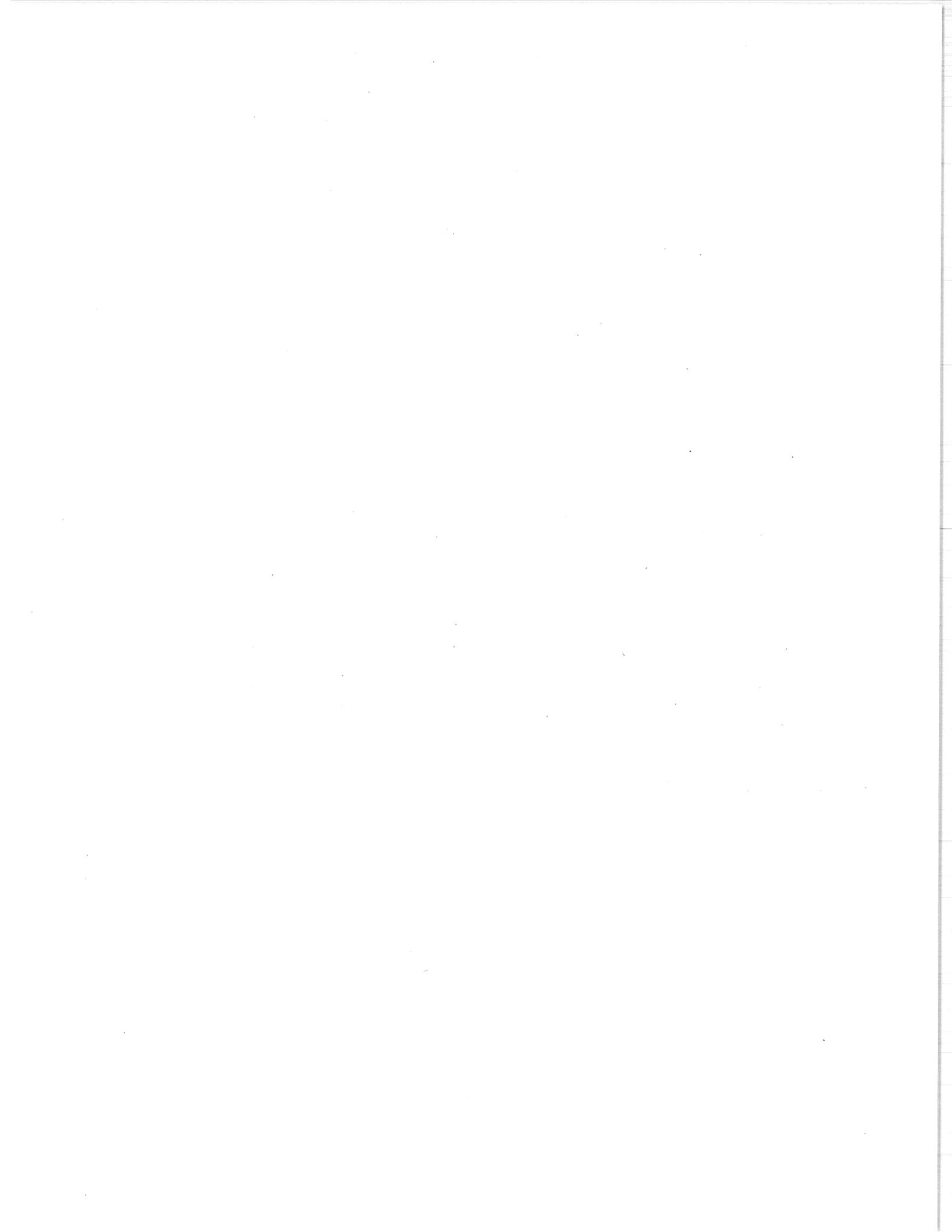

STAINLESS STEEL

SECTION 15

TABLE OF CONTENTS

	PAGE(S)
WIRE, BAR & FOIL	15-2 & 15-3
STRIP & SHEET	15-4
TUBE, WIRE CLOTH & THREADED BAR	15-5
CROSS REFERENCE INDEX	15-7 & 15-8
NOTES	15-6
MECHANICAL PROPERTIES & MISC	15-9
TOLERANCES	15-10

REFERENCES*

- STANDARD SPECIFICATION FOR STAINLESS AND HEAT-RESISTING CHROMIUM NICKEL STEEL PLATE, SHEET, AND STRIP ASTM A167
- STANDARD SPECIFICATION FOR STAINLESS AND HEAT-RESISTING CHROMIUM STEEL PLATE, SHEET, AND STRIP ASTM A176, A177
- STANDARD SPECIFICATION FOR SEAMLESS AND WELDED AUSTENITIC STAINLESS STEEL TUBING FOR GENERAL SERVICE ASTM A269
- STANDARD SPECIFICATION FOR STAINLESS AND HEAT-RESISTING STEEL BARS AND SHAPES ASTM A276
- STANDARD SPECIFICATION FOR CHROMIUM NICKEL STAINLESS AND HEAT-RESISTING STEEL SPRING WIRE ASTM A313
- STANDARD SPECIFICATION FOR GENERAL REQUIREMENTS FOR DELIVERY OF FLAT-ROLLED STAINLESS AND HEAT-RESISTING STEEL PLATE SHEET AND STRIP ASTM A480
- STANDARD SPECIFICATION FOR SEAMLESS STAINLESS STEEL MECHANICAL TUBING ASTM A511
- STANDARD SPECIFICATION FOR GENERAL REQUIREMENTS FOR STAINLESS AND HEAT-RESISTING STEEL WIRE ASTM A555
- STANDARD SPECIFICATION FOR STAINLESS AND HEAT-RESISTING STEEL WIRE ASTM A580
- STANDARD SPECIFICATION FOR FREE-MACHINING STAINLESS AND HEAT-RESISTING STEEL WIRE ASTM A581-67
- STANDARD SPECIFICATION FOR FREE-MACHINING STAINLESS AND HEAT-RESISTING STEEL BARS, HOT-ROLLED OR COLD-FINISHED ASTM A582-67
- TECHNICAL DATA SHEET FROM THE CARPENTER STEEL COMPANY
- TECHNICAL DATA SHEET FOR ARMCO 17-7PH STAINLESS STEEL FROM THE ARMCO STEEL CORP, (AMS)
- AMS-AEROSPACE MATERIAL SPECIFICATION, COOPERATIVE ENGINEERING, PROJECT WITH SAE (SOCIETY OF AUTOMOTIVE ENGINEERS).

TEK STANDARDS PERTAINING TO MATERIALS

062-1702-00	Welding, Soldering & Brazing	D-100	Die Casting & Molding Standards
062-1703-00	Finishes, Glossary of Terms		
062-1713-00	Drafting, Aluminum Extrusions	H Series	Tooling Standards
062-1718-00	Finish Quality, Cosmetic		
062-2845-00	Mechanically Applied Finishes		
062-2848-00	Bend Allowance & Deduction	062-5818-01	Aluminum (M150)
062-2850-00	Finish, Surface Texture	M-200	Brass
062-2854-00	Finishes, Chemical & Electromechanical	M-250	Copper
062-2856-00	Non-Additive Finishes for Brass, Copper & Copper Alloys	M-300	Copper-Beryllium
062-2860-00	Finishes, Anodized	M-350	Beryllium-Nickel
062-2863-00	Zinc Die Cast Finishes, Chromate Conversion Coatings	M-400	Phosphor-Bronze
062-2868-00	Finish, Etch Chromate & Lacquer (On Aluminum)	M-450	Steel
062-2868-01	Chromate Conversion Coating for Al Die Casting Alloy 3431	M-500	Stainless Steel
062-2871-00	Finish, Passivating	M-550	Magnetic Shielding Materials (Iron-Nickel & Nickel-Silver)
062-5818-00	General Information about Bulk Raw Materials	M-600	Copper-Nickel-Zinc

A STAINLESS STEEL SELECTION GUIDE HAS BEEN PUBLISHED BY KWAKU MENSAH, CORPORATE METALLURGIST. THE GUIDE INCLUDES A DESCRIPTIVE CLASSIFICATION OF STAINLESS STEELS, A GENERALIZED DISCUSSION OF MECHANICAL PROPERTIES OF METALS (DEFINITIONS AND THE SIGNIFICANCE OF TERMINOLOGY), AND THE PRINCIPLES OF CORROSION AS IT APPLIES TO ALL METALS. TO OBTAIN A COPY, CALL EXTENSION 0259 AND ASK FOR THE PAPER ON STAINLESS STEEL.

IN ADDITION, THE PAPER INCLUDES TABLES DEPICTING TYPICAL MECHANICAL AND PHYSICAL PROPERTIES OF SOME OF THE MORE COMMON STAINLESS STEELS. DESIGNERS SHOULD FIND THIS PAPER PARTICULARLY USEFUL.

STAINLESS STEEL (CONT)

WIRE

SIZE*	TYPE+	SPECIFICATION	CONDITION (TEMPER PAGE 15-9)	FINISH	EDGE	PART NUMBER	CC
.006 x .020	S30500	ASTM A580, A555	Condition A	2B	3	251-0761-00	oz H-
.006 x .312	S30100	ASTM A176/167, A480	Full Hard	2	3	251-3020-01	1b L
.006 x 1.093	S30100	ASTM A176/167, A480	Full Hard			251-3020-00	1b L
.007 x .093	S30500	ASTM A167/176, A480		2B	1	251-0832-00	1b L-
.008 x .045	S30500	Carpenter	Condition A	2B	1	251-0746-00	oz G
.008 x .200	S30100		Spring	2	3	251-0687-00	1b K
.010 x .025	S30500	Carpenter	Condition A	2B	1	251-0839-00	1b L-
.010 x .125	S30500		Condition A	2B	3	251-0731-00	oz G
.010 x .125	S30200	ASTM A313, A555	Spring	2	3	251-0835-00	oz F+
.010 x .250	S30500	Carpenter	Condition A	2B	4	251-0644-00	1b J+
.010 x .312	S30500	Carpenter	Condition A	2B	3	251-0719-00	1b K
.010 x .312	S30100	ASTM A167, A480		2	3	251-0732-00	1b J+
.010 x .500	S30500	Carpenter	Condition A	2B	3	251-0845-00	1b K-
.010 x .590	S30500/30400	ASTM A167, A480		2	3	251-0772-00	1b L-
.010 x .600	S30100	MIL-S-5059C	Full Hard			251-3036-00	1b K
.010 x .625	S30500	Carpenter	Condition A	2B	3	251-0578-00	1b K-
.010 x .750	S30500/30400	ASTM A167, A480		2B	3	251-0772-01	1b L-
.010 x 1.000	S30500	Carpenter	Condition A	2	3	251-0696-00	in A
.012 x .750	S30100	ASTM A167, A480		2	5	251-0781-02	1b L
.015 dia	S30500	ASTM A580, A555	Condition A			251-0927-00	1b N+
.015 x .188	17-7 PH	AMS 5528	Condition A	2D	3	251-0863-00	1b M-
.015 x .500	S43000	ASTM A176, A480		2	3	251-0507-00	1b K+
.016 x .040	S30500	Carpenter	Condition A	2B	1	251-0755-00	oz G
.017 x .250	S30500	Carpenter	Condition A	2B	3	251-0720-00	1b J+
.017 x .375	S30500	Carpenter	Condition A	2B	3	251-0847-00	1b J+
.017 x .500	S30500	Carpenter	One Quarter Hard	2B	3	251-3056-00	oz F-
.017 x .580	S30500	Carpenter	Condition A	2B	3	251-0843-00	1b I+
.017 x .655	S30500	Carpenter	Condition	2B	3	251-0862-00	1b J+
.017 x .750	S30500	ASTM A176	Annealed	2B	3	251-3057-00	oz F-
.017 x 1.000	S31600	ASTM A167, A480	Annealed	2B	3	251-3060-00	1b L
.018 x .187	S30500	ASTM A167, A480		2B	3	251-0808-00	1b K
.018 x .625	S30100	ASTM A167, A480	One Quarter Hard	2	3	251-0729-01	1b J-
.018 x 1.000	S30100	ASTM A167, A480	One Quarter Hard	2	3	251-0729-00	1b K-
.020 x .125	S30500	Carpenter	Condition A	2B	1	251-0569-00	oz G
.020 x .312	S30400	ASTM A580, A555	Condition A	Cold Drawn	Radius	251-0775-00	1b K+
.020 x .625	S30400	ASTM A580, A555	Condition A	Cold Drawn	Radius	251-0775-01	1b K-
.025 dia	S30500	ASTM A580/581, A555	Condition A	Cold Drawn		251-0828-00	1b L-
.025 x .125	S30500	ASTM A167		2B	3	251-0765-00	1b L
.025 x .125	S30500	ASTM A167, A480	Condition A	2B		251-0999-00	1b K+
.025 x .200	S30500	Carpenter	Condition A	2B	3	251-0906-00	1b K
.025 x .250	S30100/30200	ASTM A167, A480		2B	3	251-0624-00	ft D+
.025 x .250	S30500	Carpenter	Rockwell Suprfcl. 30N 50 MIN	2B	3	251-0635-00	oz F-
.025 x .2812	S30500	Carpenter	Rockwell Suprfcl. 30N 50 MIN	2B	3	251-0694-00	1b J
.025 x .295	S30500	ASTM A167, A480	Cold Rolled	2B	3	251-0993-00	1b J+
.025 x .400	S30500	ASTM A167, A480		2B	3	251-3006-00	1b K
.025 x .500	S30500	Carpenter	Condition			251-0917-00	1b J+
.025 x .810	S30500	ASTM A167, A480				251-3003-00	1b J+
.025 x 1.000	S30500	Carpenter	Condition A	2B	3	251-0603-00	1b J+
.030 sq	S30500	ASTM A167, A480				251-0747-00	oz G
.031 x .750	S30500	Carpenter	Condition A	2B	3	251-0568-00	1b J
.031 x .750	S30100	ASTM A167, A480	Spring	2	5	251-0688-00	1b K
.031 x 1.000	S30500	ASTM A167, A480	Condition A	2B		251-0991-00	1b J+
.031 x 1.000	S30200/30400	ASTM A167, A480	Condition A	2B	3	251-0960-00	1b K-
.035 dia	S30200	ASTM A313, A555	Spring	Cold Drawn	3	251-0686-00	oz G+
.040 dia	S30500	Carpenter	Condition A	Cold Drawn		251-0657-00	in A-
.050 dia	17-7 PH		Condition A			251-0730-00	ft D-
.060 dia	S30500	Carpenter	Condition A	Cold Drawn		251-0649-00	in A-
.062 dia ±.001	S30300	ASTM A581, A555	Half Hard	Cold Drawn		251-0901-00	ft H
.062 x .850	S30200	ASTM A167, A480	Half Hard			251-0563-02	ft G+
.072 dia	17-7 PH	AMS-5673 A				251-0727-00	1b L-
.080 sq ±.002	S30400	ASTM A580, A555	Condition A	Cold Drawn		251-0776-00	1b L
.081 dia	S30400	ASTM A580, A555	Half Hard	Cold Drawn		251-0855-00	1b K+
.0937 dia	S30300	ASTM A581, A555	Condition A	Centerless Gnd		251-0662-00	oz G
.094 dia	17-4 PH		Annealed			251-3052-00	1b M+

* TOLERANCES CAN BE FOUND ON PAGE 15-10.

+ FOR MECHANICAL PROPERTIES, SEE PAGE 15-9.

STAINLESS STEEL (CONT)

WIRE (CONT)

SIZE *	TYPE †	SPECIFICATION	CONDITION (TEMPER PAGE 15-9)	FINISH	PART NUMBER	CC
.095 dia	S30300	ASTM A581, A555	Condition A	Centerless Ground & Polished	251-0670-00	ft F-
.100 x .120	S30400	ASTM A580, A555	Condition A	Cold Drawn	251-0771-00	1b K+
.118 dia	S30200	ASTM A313, A555	Spring		251-0864-00	1b K-
.1247 dia	S30300	ASTM A581, A555	One-quarter Hard		251-0714-00	ft H
.125 dia	S30300	ASTM A581, A555	Condition	Cold Drawn	251-0518-00	ft F-
.125 dia x 64 long	S43000	ASTM A580, A555	Condition A	Centerless Ground & Polished	251-0581-00	1b K-
.155 dia	S43000F	Carpenter	Condition A	Solenoid Quality	251-0792-00	1b K
.156 dia ± .001 x 120 + .500 - .000	S30300	ASTM A581, A555	Condition A	Cold Drawn	251-0625-00	1b K
.187 dia	S30300	ASTM A581, A555	Condition A	Centerless Ground & Polished	251-0539-01	1b K+
.188 dia ± .001	S30300	ASTM A581, A555	Condition A	Centerless Ground & Polished	251-0539-00	1b K-
.188 hex	S30300	ASTM A581, A555	Condition A	Cold Drawn	251-0875-00	1b K
.188 hex	S41600	ASTM A581, A555	Condition A	Cold Drawn	251-0970-00	1b K
.188 sq	S30300	ASTM A581, A555	Condition A		251-0973-00	ft H+
.219 dia	S30300	ASTM A581, A555	Condition A	Cold Drawn	251-0751-00	1b J+
.249 dia	S30300	ASTM A581, A555	Condition A	Centerless Ground & Polished	251-0640-00	1b K-
.250 dia	S30300	ASTM A581, A555	Condition A	Centerless Ground	251-0538-00	1b K-
.250 hex	S30300	ASTM A581, A484	Condition A		251-3049-00	1b K-
.250 dia	S30400	ASTM A581, A555	Condition A	Centerless Ground	251-0883-00	1b J+
.312 dia ± .0015	S30300	ASTM A581, A555	Condition A	Centerless Ground	251-0639-00	1b K
.312 dia ± .0005	S30300	ASTM A581, A555	Condition A	Centerless Ground	251-0639-01	1b K+

SIZE	TYPE †	SPECIFICATION	CONDITION (TEMPER PAGE 15-9)	FINISH	PART NUMBER	CC
.100 x .125	17-4 PH	AMS 5643	Condition A		251-0836-00	1b L-
.109 x .800	S30200	ASTM A167, A480	Condition A	2B Finish Centr's Gnd & Polished	251-3025-00	1b J+
.102 x 4.000 x 52 long	S30200	ASTM A167, A480	Condition A	2B Finish	251-3024-00	1b J+
.125 x .625	S30200/30400	ASTM A177, A480	One-quarter Hard	Cold Drawn	251-0890-00	1b K-
.150 x .625	S30200/30400	ASTM A167,176, A480	Condition A	Cold Drawn	251-0890-02	1b K-
.375 dia	S30300	ASTM A581, A555	Condition A	Centerless Ground	251-0626-00	1b J+
.375 hex	S30300	ASTM A581, A555	Condition A	Cold Drawn	251-0708-00	1b K-
.375 dia x 12 ft			Condition A		251-0810-00	1b K
.438 dia	S41600	ASTM A581, A555	Condition A	Cold Finished	251-0774-00	1b K-
.438 hex	S31600	ASTM A580, A555	Condition A	Cold Drawn	251-0700-00	1b K
.438 hex	S30300	ASTM A581, A555	Condition A	Cold Drawn	251-0757-00	1b K
.500 dia	S30300	ASTM A581, A555	Condition A	Centerless Ground & Polished	251-0542-00	1b J+
.505 dia	S30300	ASTM A582, A555	Condition A	Centerless Ground & Polished	251-3001-00	1b J+
.562 dia	S430F	Carpenter	Condition A	Solenoid Quality	251-0793-00	1b J+
.562 dia	S41600	ASTM A582, A555	Condition A	Cold Finished	251-0631-00	1b J+
.562 dia	S30300	ASTM A582, A555	Condition A	Cold Finished	251-0701-00	1b J+
.625 dia	S30300	ASTM A582, A555	Condition A	Centerless Ground & Polished	251-0598-00	1b K-
.625 hex	S30300	ASTM A582, A555	Condition A	Cold Drawn	251-0919-00	1b K-
.750 dia	S30300	ASTM A582, A555	Condition A	Cold Finished	251-0699-00	1b K-
.875 dia	S30300	ASTM A582, A555	Condition A	Cold Finished	251-0684-00	
1.000 dia	S30300	ASTM A582, A555	Condition A	Cold Finished	251-0715-00	1b J+
1.187 dia	S30300	ASTM A582, A555	Condition A	Cold Finished	251-0750-00	1b K-
1.500 dia	S30300	ASTM A582, A555	Condition A	Cold Finished	251-0742-00	1b J+

SIZE	TYPE †	SPECIFICATION	CONDITION (TEMPER PAGE 15-9)	FINISH	EDGE	PART NUMBER	CC
.002 x .120	S30400	ASTM A177, A480	Condition H			251-0992-00	1b N
.002 x 6.000 x 50.000	S30100/30200	ASTM A177	Condition H	2B	3	251-0711-00	1b N-
.002 x 12.000	S316L	ASTM A167	Condition A	2B		251-3031-00	1b M+
.0025 ± .0005 x .266	S30100	ASTM A177, A480	Condition H	2B	3	251-0972-00	1b L+
.003 x .125	S30400	ASTM A167	Condition A	2B	3	251-3026-00	1b M+
.003 x .312	S30100	ASTM A177, A480	Full Hard	2	3	251-3019-04	1b M-
.003 x .655	S30100	ASTM A177, A480	Full Hard	2	3	251-3019-02	1b M+
.003 x .797	S30100	ASTM A177, A480	Full Hard	2	3	251-3019-05	1b J
.003 x .812	S30100	ASTM A177, A480	270 ksi, Extra Hard/ Spring	2B	1	251-0728-00	ft D+
.003 x 3.018	S30100	ASTM A177, A480	Full Hard	2	3	251-3019-00	1b L-
.003 x 4.734	S30100	ASTM A177, A480	Full Hard	2	3	251-3019-01	1b L-
.003 x 6.000	S30100	ASTM A177, A480	Full Hard	2	3	251-3019-03	1b L-
.003 x 12.000	S316L	ASTM A167, A480	Condition A	2B		251-3032-00	1b M
.004 x 2.750	S30500	Carpenter	Condition H	2B	3	251-0617-00	oz F+
.005 x .250	S30500	Carpenter	Condition A	2B	3	251-0904-00	1b I
.005 x .375	S30500	Carpenter	Condition A	2B	3	251-0880-00	1b K+
.005 x 3.750	S43000	ASTM A176, A480		2B	3	251-0867-00	1b J+
.005 x 6.000	S30200	ASTM A177, A480	Spring Temper	2	3	251-0892-00	1b L

* TOLERANCES CAN BE FOUND ON PAGE 15-10.
† FOR MECHANICAL PROPERTIES, SEE PAGE 15-9.

STAINLESS STEEL (CONT)

STRIP

SIZE *	TYPE †	SPECIFICATION	CONDITION (TEMPER)**	FINISH	EDGE	PART NUMBER	CC
.009 x 6.000	S30200	ASTM A167, A480	Condition H	2	3	251-0813-00	1b K
.010 x 1.500	S30500	Carpenter	Condition A	2B	3	251-0579-00	1b J+
.010 x 1.500	S30500	ASTM A370	Rockwell 30N 45-50	2B	3	251-0894-00	1b J+
.010 x 1.700	S30500	Carpenter	Condition A	2B	3	251-0766-00	1b J+
.010 x 1.750	S30500	ASTM A370	Rockwell Suprfl. 15N 75 MIN	2B	3	251-0627-00	1b I
.010 x 2.250	S30500	ASTM A370	Rockwell Suprfl. 15N 75 MIN	2B	3	251-0554-00	1b K
.010 x 2.375	S30500	Carpenter	Condition A	2B	3	251-0656-00	oz F
.010 x 3.625	S30500	Carpenter	Condition A	2B	3	251-0673-00	1b J+
.010 x 6.000	S30500	Carpenter	Condition A	2B	3	251-0706-00	1b J+
.012 x 6.000	S30100	ASTM A167, A480	Extra Hard Spring	2D	3	251-0781-01	1b I+
.016 x 1.875	17-7 PH	AMS		2D	3	251-0796-00	1b L-
.017 x 1.625	S30500	Carpenter	Condition A	2B	3	251-0643-00	oz F-
.017 x 2.000	S31600		Annealed	2B		251-3065-00	
.017 x 2.000	S30500	Carpenter	Condition A	2B	2	251-0672-00	1b J+
.017 x 2.250	S31600	ASTM A580, A555	One-quarter Hard	2	3	251-1725-00	
.017 x 2.625	S30500	Carpenter	Condition A	2B	3	251-0721-00	1b J+
.017 x 2.625	S30500	Carpenter	One-quarter Hard	2B	3	251-0968-00	1b J+
.017 x 3.250	S30500	Carpenter	Condition A	2B	3	251-0897-00	1b J+
.017±.0015x2.250±.016	S31600	ASTM A167	One-quarter Hard	2B	3	251-3062-00	1b K
.018 x 6.000	S30100	ASTM A167, A480	One-quarter Hard	2	3	251-0729-03	1b K
.020 x 2.125	S30500	Carpenter	Condition A	2B	3	251-0844-00	1b J+
.020 x .322	17-7 PH	AMS	Condition A	2B	3	251-0987-00	1b K
.020 x 9.000	17-7 PH	AMS	Condition C (Cold Rolled)	2D	3	251-0809-00	1b K
.025 x 1.375	S30500	Carpenter	Condition A	2B	3	251-0604-00	1b J+
.025 x 1.500	S30500	Carpenter	Condition A	2B	3	251-0571-00	1b J+
.025 x 1.750	S30500	ASTM A370	Rockwell Suprfl. 30N 15 MIN	2B	3	251-0629-00	1b I
.025 x 1.750	S30500	Carpenter	Condition A	2B	3	251-0572-00	1b J+
.025 x 1.875	S30500	Carpenter	Condition A	2B	3	251-0573-00	1b J+
.025 x 2.000 ±.005	S30500	ASTM A167, A480	Condition A	2B		251-0995-00	1b J
.025 x 2.250	S30500	Carpenter	Condition A	2B	3	251-0574-00	1b J+
.025 x 2.625	S30500	Carpenter	Condition A	2B	3	251-0660-00	1b J+
.025 x 2.625	S30500	ASTM A370	Rockwell Suprfl. 30N 45-50	2B	3	251-0663-00	1b J+
.025 x 2.750	S30500	ASTM A370	Rockwell Suprfl. 30N 50 MIN	2B	3	251-0634-00	1b J+
.025 x 3.375	S30100	ASTM A167, A480	One-quarter Hard	2D	3	251-0709-00	1b J+
.025 x 3.375	S30500	ASTM A370	Rockwell Suprfl. 30N 50 MIN	2B	3	251-0567-00	1b J
.025 x 3.500	S30500	Carpenter	Condition A	2B	3	251-0818-00	1b J+
.025 x 4.000	S30500	ASTM A370	One-half Hard	2B	3	251-0773-00	1b J+
.025 x 6.250	S30500	Carpenter	Condition A	2B	3	251-0764-00	1b J
.025 x 11.000 x 30.000	S30500	ASTM A167, A480	Cold Rolled	2D	3	251-0517-00	1b J+
.031 x 1.750	S30500	Carpenter	Condition A	2B	3	251-0628-00	1b J+
.031 x 2.250	S30500	Carpenter	Condition A	2B	3	251-0577-00	1b J+
.031 x 2.875	S30500	Carpenter	Condition A	2B	3	251-0615-00	1b J+
.031 x 3.250	S30500	Carpenter	Condition A	2B	3	251-0616-00	1b I+
.038 x 3.000	S30400	ASTM A167, A480	Condition A	2B	1	251-0797-01	1b J+
.050 x 3.000	S30100	ASTM A167, A480	One-quarter Hard	2B	3	251-0718-01	1b K

SHEET

SIZE *	TYPE †	SPECIFICATION (ASTM)	CONTITION (TEMPER)**	FINISH	PART NUMBER	CC
.017 x 22.750	S30500	A167, A480	Condition A	2B	251-0923-00	1b J-
.018 ±.003 x 36 +.062 x 120 + .125	S30200/30400	A167, A480	Condition A	2B	251-0531-00	1b J+
.020 x 36 x 120	S30100	A167, A480	Condition H	2B	251-0801-00	1b J+
.025 x 36 x 120	S30100	A167, A480	One-half Hard	2B	251-0624-01	1b J
.025 x 36 x 96	S30100	A167, A480	One-quarter Hard	2B	251-0802-00	1b K-
.025 x 23.938	S30500	A167, A480	Condition A	2B	251-0922-00	1b I+
.025 x 36 x 120	17-7 PH	AMS	Condition A	2D	251-0788-00	1b K
.031 ±.004 x 36 +.062 x 120 + .125	S30200/30400	A167, A480	Condition A	2B	251-0501-00	1b J
.032 ±.004 x 36 +.062 x 120 + .250	17-7 PH	A693	Condition A	2D	251-0984-00	1b K-
.038 x 36 x 96	S30400	A167, A480	Condition A	2B	251-0797-00	1b J-
.038 x 36 x 120	S30100	A167, A480	One-half Hard	4	251-0562-00++	1b J
.050 ±.005 x 36 + .062 x 120 + .165	S30100	A167, A480	One-quarter Hard	2D	251-0718-00	1b J
.050 x 36 x 120	S30400	A167, A480	Condition A	2B	251-0704-00	1b J-
.062 x 36 x 120	S30200	A167, A480	One-half Hard	2D	251-0563-00	1b J
.062 x 48 x 120	S30200	A167, A480	Condition A	2B	251-0798-00	1b I+
.090 ±.008 x 36 + .062 x 120 + .250	S30100	A167, A480	One-quarter Hard	2B	251-0805-00	1b J
.109 x 36 x 120	S30200	A167, A480	One-quarter Hard	2B	251-0763-00	1b I

* TOLERANCES CAN BE FOUND ON PAGE 15-10.

** CONDITION A - ANNEALED

† FOR MECHANICAL PROPERTIES, SEE PAGE 15-9.

++ ADHESIVE PAPER ONE SIDE.

STAINLESS STEEL (CONT)

TUBE

SIZE *	TYPE †	SPECIFICATION	CONDITION (TEMPER)**	OTHER	PART NUMBER	CC
.093 OD x .008 Wall	S32100	MIL-T-8808A	Condition H		251-0733-00	ft I+
.125 OD x .016 Wall	S30400	ASTM A269	Condition H	Cold Drawn, Seamless	251-0790-01	ft I-
.125 OD ±.001 x .016 Wall	S30400	ASTM A269	Condition H	Cold Drawn, Seamless	251-0790-02	ft I
.1243 OD ±.0003 x .016 Wall	S30400	ASTM A269	Condition H		251-0790-03	ft I-
.156 OD x .144 ID	S32100	MIL-T-8808A	Condition A		251-0789-00	ft H+
.189 +.0015 -.001 x .007 Wall ±.0007	S30200/30400	ASTM A269	One-half Hard		251-0674-00	ft J+
.240 ±.005 OD x .158 ±.001 ID	S30300	Vendor	Condition A		251-0652-00	ft K-
.375 OD x .042 Wall	S30400	ASTM A269	Condition A	Welded & Drawn	251-0762-00	ft J
.498 +.000 -.002 OD x .375 +.002 -.000	S30400	ASTM A269	Condition A	64 μ in Finish	251-0695-00	ft K
.625 OD x .503 ID ±.002	S30400	ASTM A269	Condition A	Welded & Drawn	251-0827-00	ft J+
1.000 OD x .976 ID	S30500	Vendor	Condition A	Welded & Drawn	251-0611-00	ea J
1.105 ID x .010 Wall	S30500	Vendor	Condition A	Welded	251-0918-00	ft K
1.495 ID x .010 Wall	S30500	Vendor	Condition A	Welded & Bead Rolled	251-0830-00	ft J+
1.500 OD x .049 Wall	S30400	ASTM A269	Condition A	180 Grit Brushed Finish	251-0743-00	ft J+
1.980 ID x .010 Wall	S30500	ASTM A554	Condition A	Welded & Bead Rolled	251-0893-00	ft L

WIRE CLOTH

251-0824-00	105 x 105 Mesh, .003 dia wire	18 x 28	CC: M	sh
251-0824-01	105 x 105 Mesh, .003 dia wire	18 x 28, Satin Chrome Coat	CC: 0-	ea
251-3048-00	200 x 200 Mesh, 7 x 7 x .002 thick,	1/4 Hard, Type 304	CC: J	ea
251-0689-00	200 x 200 Mesh, .0021 x 22 wide,	Type 304, One-quarter Hard	CC: K-	sf
251-0689-01	200 x 200 Mesh, .0021 x 22 with black	Chromate Coat, Type 304, One-quarter Hard	CC: 0-	ea

CONTINUOUS THREAD BAR (ASTM A581, ALLOY S30300)

251-0744-00	4-40 UNC-2A	CC: I	ft
251-0873-00	10-32, UNF-2A	CC: I	ft
251-0978-00	4-40 UNC-2A (Alloy S30400)	CC: I+	ea

COST CODE

(CC COLUMN)

CODE	A	B	C	D	E	F	G	H	I	J	K	L	M	N	O
≈ VALUE with +	.75¢	2¢	3.75¢	6¢	10¢	18¢	35¢	60¢	\$1	\$2	\$3.75	\$6	\$10	\$18	\$35+
≈ VALUE no suffix	.5¢	1.5¢	3¢	5¢	8¢	15¢	25¢	50¢	75¢	\$1.50	\$3	\$5	\$8	\$15	\$25
≈ VALUE with -	.2¢	1.25¢	2.5¢	4.25¢	7¢	13¢	22¢	40¢	65¢	\$1.25	\$2.50	\$4.25	\$7	\$13	\$22

NOTE: Costs may vary from order to order due to order quantities, vendor, etc.

† FOR MECHANICAL PROPERTIES, SEE PAGE 15-9.
 * TOLERANCES CAN BE FOUND ON PAGE 15-10.
 ** CONDITION A = ANNEALED.

NOTES

COST CODE

(CC COLUMN)

CODE	≈ VALUE with -	≈ VALUE no suffix	≈ VALUE with +
A	.2¢	.5¢	.75¢
B	1.25¢	1.5¢	2¢
C	2.5¢	3¢	3.75¢
D	4.25¢	5¢	6¢
E	7¢	8¢	10¢
F	13¢	15¢	18¢
G	22¢	25¢	35¢
H	40¢	50¢	60¢
I	65¢	75¢	\$1
J	\$1.25	\$1.50	\$2
K	\$2.50	\$3	\$3.75
L	\$4.25	\$5	\$6
M	\$7	\$8	\$10
N	\$13	\$15	\$18
O	\$22	\$25	\$35+

NOTE: Costs may vary from order to order
due to order quantities, vendor, etc.

CROSS REFERENCE INDEX

PART NUMBER	DESCRIPTION	SIZE	PAGE NO.	STATUS§§	PART NUMBER	DESCRIPTION	SIZE	PAGE NO.	STATUS§§
251-0501-00	Sheet	.031 x 36.000 x 120.000	15-4	CR	251-0706-00	Strip	.010 x 6.000	15-4	CR
251-0507-00	Wire	.015 x .500	15-2	CR	251-0707-00	Strip	.025 x 6.000		DL
251-0517-00	Strip	.025 x 11.000 x 30.000	15-4	CR	251-0708-00	Bar	.375 hex	15-3	CR
251-0518-00	Wire	.125 dia	15-3	CR	251-0709-00	Strip	.025 x 3.375	15-4	CR
251-0531-00	Sheet	.018 x 36.000 x 120.000	15-4	CR	251-0711-00	Foil	.002 x 6.000 x 50.000	15-3	CR
251-0532-00	Wire	.125 dia		NP	251-0711-01	Foil	.003 x 6.000		NP
251-0535-00	Wire	.125 dia		NP	251-0714-00	Wire	.1247 dia	15-3	CR
251-0538-00	Wire	.250 dia	15-3	CR	251-0714-01	Wire	.130 dia		DL
251-0539-00	Wire	.188 dia	15-3	CR	251-0715-00	Bar	1.000 dia	15-3	OT
251-0539-01	Wire	.187 dia	15-3	CS	251-0718-00	Sheet	.050 x 36.000 x 120.000	15-4	CR
251-0542-00	Bar	.500 dia	15-3	CR	251-0718-01	Strip	.050 x 3.000	15-4	CR
251-0554-00	Strip	.010 x 2.250	15-4	CR	251-0719-00	Wire	.010 x .312	15-2	CR
251-0562-00	Sheet	.038 x 36.000 x 120.000	15-4	CR	251-0720-00	Wire	.017 x .250	15-2	CR
251-0563-00	Sheet	.062 x 36.000 x 120.000	15-4	CR	251-0721-00	Strip	.017 x 2.625	15-4	CR
251-0563-02	Wire	.062 x .850	15-2	CR	251-0727-00	Wire	.072 dia	15-2	CR
251-0567-00	Strip	.025 x 3.375	15-4	CR	251-0728-00	Foil	.003 x .812	15-3	CR
251-0568-00	Wire	.030 x .750	15-2	CR	251-0729-00	Wire	.018 x 1.000	15-2	CR
251-0569-00	Wire	.020 x .125	15-2	CR	251-0729-01	Wire	.018 x .625	15-2	OB
251-0571-00	Strip	.025 x 1.500	15-4	CR	251-0729-03	Strip	.018 x 6.000	15-4	CR
251-0572-00	Strip	.025 x 1.750	15-4	CR	251-0730-00	Wire	.050 dia	15-2	CR
251-0573-00	Strip	.025 x 1.875	15-4	CR	251-0731-00	Wire	.010 x .125	15-2	CR
251-0574-00	Strip	.025 x 2.250	15-4	CR	251-0732-00	Wire	.010 x .312	15-2	CS
251-0577-00	Strip	.031 x 2.250	15-4	CR	251-0733-00	Tube	.093 OD x .008 Wall	15-5	CR
251-0578-00	Wire	.010 x .625	15-2	CR	251-0742-00	Bar	1.500 dia	15-3	CS
251-0579-00	Strip	.010 x 1.500	15-4	CR	251-0743-00	Tube	1.500 ID x .049 Wall	15-5	CR
251-0581-00	Wire	.125 dia	15-3	CR	251-0744-00	Thread Bar	4-40 UNC-2A	15-5	CR
251-0598-00	Bar	.625 dia	15-3	CR	251-0746-00	Wire	.008 x .045	15-2	CR
251-0603-00	Wire	.025 x 1.000	15-2	CR	251-0747-00	Wire	.030 Sq	15-2	CR
251-0604-00	Strip	.025 x 1.375	15-4	CR	251-0750-00	Bar	1.187 dia	15-3	CR
251-0611-00	Tube	1.000 OD x .976 ID	15-5	CR	251-0751-00	Wire	.219 hex	15-3	CR
251-0615-00	Strip	.031 x 2.875	15-4	CR	251-0754-00	Wire	.010 x .438		NP
251-0616-00	Strip	.031 x 3.250	15-4	CR	251-0755-00	Wire	.016 x .040	15-2	CR
251-0617-00	Foil	.004 x 2.750	15-3	CR	251-0757-00	Bar	.438 hex	15-3	CR
251-0624-00	Wire	.025 x .250	15-2	CR	251-0761-00	Wire	.006 x .020	15-2	CR
251-0624-01	Sheet	.025 x 36.000 x 120.000	15-4	CR	251-0762-00	Tube	.375 OD x .042 Wall	15-5	CS
251-0625-00	Wire	.156 dia	15-3	CR	251-0763-00	Sheet	.109 x 36.000 x 120.000	15-4	CS
251-0626-00	Bar	.375 dia	15-3	CR	251-0764-00	Strip	.025 x 6.250	15-4	CR
251-0627-00	Strip	.010 x 1.750	15-4	CR	251-0765-00	Wire	.025 x .125	15-2	CS
251-0628-00	Strip	.031 x 1.750	15-4	CR	251-0766-00	Strip	.010 x 1.700	15-4	CR
251-0629-00	Strip	.025 x 1.750	15-4	CR	251-0768-00	Wire	.020 dia		DL
251-0631-00	Bar	.562 dia	15-3	CR	251-0771-00	Wire	.100 x .120	15-3	CR
251-0633-00	Strip	.010 x 2.625	15-3	OB	251-0772-00	Wire	.010 x .590	15-2	CS
251-0634-00	Strip	.025 x 2.750	15-4	CR	251-0772-01	Wire	.010 x .750	15-2	CS
251-0635-00	Wire	.025 x .250	15-2	CR	251-0773-00	Strip	.025 x 4.000	15-4	CR
251-0639-00	Wire	.312 dia	15-3	CR	251-0774-00	Bar	.438 dia	15-3	CR
251-0639-01	Wire	.312 dia	15-3	CR	251-0775-00	Wire	.020 x .312	15-2	CR
251-0640-00	Wire	.249 dia	15-3	CR	251-0775-01	Wire	.020 x .625	15-2	CR
251-0643-00	Strip	.017 x 1.625	15-4	CR	251-0776-00	Wire	.080 Sq	15-2	CS
251-0644-00	Wire	.010 x .250	15-2	CR	251-0781-00	Wire	.012 x .250		DL
251-0649-00	Wire	.060 dia	15-2	CR	251-0781-01	Strip	.012 x 6.000	15-4	CR
251-0652-00	Tube	.240 OD x .158 ID	15-5	CR	251-0781-02	Wire	.012 x .750	15-2	CS
251-0656-00	Strip	.010 x 2.375	15-4	CR	251-0782-00	Wire	.015 x .322		DL
251-0657-00	Wire	.040 dia	15-2	CR	251-0783-00	Wire	.059 x .186		DL
251-0660-00	Strip	.025 x 2.625	15-4	CR	251-0788-00	Sheet	.025 x 36.000 x 120.000	15-4	CR
251-0662-00	Wire	.0937 dia	15-2	CR	251-0789-00	Tube	.156 OD x .144 ID	15-5	CS
251-0663-00	Strip	.025 x 2.625	15-4	CR	251-0790-01	Tube	.125 OD x .016 Wall	15-5	CR
251-0669-00	Wire	.008 x .055		DL	251-0790-02	Tube	.125 OD x .016 Wall	15-5	CR
251-0670-00	Wire	.095 dia	15-3	CR	251-0790-03	Tube	.1243 OD x .016 Wall	15-5	CR
251-0672-00	Strip	.017 x 2.000	15-4	CR	251-0792-00	Wire	.155 dia	15-3	CR
251-0673-00	Strip	.010 x 3.625	15-4	CR	251-0793-00	Bar	.562 dia	15-3	CR
251-0674-00	Tube	.189 OD x .007 Wall	15-5	CS	251-0796-00	Strip	.016 x 1.875	15-4	CR
251-0684-00	Bar	.875 dia	15-3	OB	251-0797-00	Sheet	.038 x 36.000 x 96.000	15-4	CR
251-0685-00	Tube	.243 OD x .160 ID		NP	251-0797-01	Strip	.038 x 3.000	15-4	CR
251-0686-00	Wire	.035 dia	15-2	CR	251-0798-00	Sheet	.062 x 48.000 x 120.000	15-4	CR
251-0687-00	Wire	.008 x .200	15-2	CR	251-0799-00	Wire	.062 x .062		DL
251-0688-00	Wire	.031 x .750	15-2	CR	251-0801-00	Sheet	.020 x 36.000 x 120.000	15-4	CR
251-0689-00	Wire Cloth	.0021 x 22.000	15-5	CR	251-0801-01	Strip	.020 x 1.438		DL
251-0689-01	Wire Cloth	.0021 x 22.000	15-5	CR	251-0802-00	Sheet	.025 x 36.000 x 96.000	15-4	CR
251-0694-00	Wire	.025 x .2812	15-2	CR	251-0805-00	Sheet	.090 x 36.000 x 120.000	15-4	CR
251-0695-00	Tube	.498 OD x .375 ID	15-5	CR	251-0808-00	Wire	.018 x .187	15-2	CR
251-0696-00	Wire	.010 x 1.000	15-2	CR	251-0809-00	Strip	.020 x 9.000	15-4	CR
251-0699-00	Bar	.750 dia	15-3	CR	251-0810-00	Bar	.375 dia	15-3	OB
251-0700-00	Bar	.438 hex	15-3	CR	251-0813-00	Strip	.009 x 6.000	15-4	CR
251-0701-00	Bar	.562 dia	15-3	CR	251-0818-00	Strip	.025 x 3.500	15-4	CR
251-0704-00	Sheet	.050 x 36.000 x 120.000	15-4	CR	251-0824-00	Wire Cloth	.003 x 18.000 x 28.000	15-4	CR

CROSS REFERENCE INDEX (CONT)

PART NUMBER	DESCRIPTION	SIZE	PAGE NO.	STATUS§§
251-0824-01	Wire Cloth	.003 x 18.000 x 28.000	15-5	CR
251-0826-00	Sheet	.062 x 36.000 x 120.000		DL
251-0827-00	Tube	.625 OD x .503 ID	15-5	CR
251-0828-00	Wire	.025 dia	15-2	CR
251-0830-00	Tube	1.495 ID x .010 Wall	15-5	CR
251-0832-00	Wire	.007 x .093	15-2	CR
251-0835-00	Wire	.010 x .125	15-2	CS
251-0836-00	Bar	.100 x .125	15-3	CS
251-0839-00	Wire	.010 x .025	15-2	CR
251-0843-00	Wire	.017 x .580	15-2	CR
251-0844-00	Strip	.020 x 2.125	15-4	CR
251-0845-00	Wire	.010 x .500	15-2	CR
251-0847-00	Wire	.017 x .375	15-2	CR
251-0848-00	Foil	.004 x 12.000		DL
251-0855-00	Wire	.081 dia	15-2	CR
251-0862-00	Wire	.017 x .655	15-2	CR
251-0863-00	Wire	.015 x .188	15-2	CR
251-0864-00	Wire	.118 dia	15-3	CR
251-0867-00	Foil	.005 x 3.750	15-3	CR
251-0873-00	Thread Bar	10-32, UNF-2A	15-5	CS
251-0875-00	Wire	.188 hex	15-3	CR
251-0880-00	Foil	.005 x .375	15-3	CR
251-0882-00	Tube	.250 OD x .095 Wall		DL
251-0883-00	Wire	.250 dia	15-3	CR
251-0890-00	Bar	.125 x .625	15-3	CR
251-0890-02	Bar	.150 x .625	15-3	CR
251-0892-00	Foil	.005 x 6.000	15-3	CR
251-0893-00	Tube	1.980 ID x .010 Wall	15-5	CR
251-0894-00	Strip	.010 x 1.500	15-4	CR
251-0897-00	Strip	.017 x 3.250	15-4	CR
251-0901-00	Wire	.062 dia	15-2	CR
251-0903-00	Wire	.010 x .270		NP
251-0904-00	Foil	.005 x .250	15-3	CR
251-0906-00	Wire	.025 x .200	15-2	CR
251-0917-00	Wire	.025 x .500	15-2	CR
251-0918-00	Tube	1.105 ID x .010 Wall	15-5	CR
251-0919-00	Bar	.625 hex	15-3	CR
251-0922-00	Sheet	.025 x 23.938	15-4	CR
251-0923-00	Sheet	.017 x 22.750	15-4	CR
251-0927-00	Wire	.015 dia	15-2	CR
251-0960-00	Wire	.031 x 1.000	15-2	CR
251-0968-00	Strip	.017 x 2.625	15-4	CR
251-0970-00	Wire	.188 hex	15-3	CR
251-0972-00	Foil	.0025 x .266	15-3	EN
251-0973-00	Wire	.188 Sq	15-3	CR
251-0978-00	Thread Bar	4-40 UNC-2B	15-5	CR
251-0984-00	Sheet	.032 x 36.000 x 120.000	15-4	CR
251-0987-00	Strip	.020 x .322	15-4	CR
251-0989-00	Foil	.003 x .145		DL
251-0991-00	Wire	.031 x 1.000	15-2	CR
251-0992-00	Foil	.002 x .120	15-3	CR
251-0993-00	Wire	.025 x .295	15-2	CR
251-0995-00	Strip	.025 x 2.000	15-4	PP
251-0999-00	Wire	.025 x .125	15-2	CR
251-1725-00	Strip	.017 x 2.250	15-4	PP
251-3001-00	Bar	.505 dia	15-3	CR
251-3003-00	Wire	.025 x .810	15-2	CR
251-3006-00	Wire	.025 x .400	15-2	CR
251-3007-00	Wire	.250 Sq		DL
251-3009-00	Foil	.001 x 6.000		DL
251-3016-00	Bar	.199 x 4.000		DL
251-3018-00	Foil	.003 x .655		DL
251-3019-00	Foil	.003 x 3.018	15-3	CR
251-3019-01	Foil	.003 x 4.734	15-3	CR
251-3019-02	Foil	.003 x .655	15-3	CR
251-3019-03	Foil	.003 x 6.000	15-3	CR
251-3019-04	Foil	.003 x .312	15-3	CR
251-3019-05	Foil	.003 x .797	15-3	CR
251-3020-00	Wire	.006 x 1.093	15-2	CR
251-3020-01	Wire	.006 x .312	15-2	CR
251-3022-00	Wire	.010 x .500		DL
251-3024-00	Bar	.109 x .400 x 52.000	15-3	CR
251-3025-00	Bar	.109 x .800	15-3	CR
251-3026-00	Foil	.003 x .125	15-3	CR
251-3031-00	Foil	.002 x 12.000	15-3	CR

PART NUMBER	DESCRIPTION	SIZE	PAGE NO.	STATUS§§
251-3032-00	Foil	.003 x 12.000	15-3	CR
251-3036-00	Wire	.010 x .600	15-2	CR
251-3048-00	Wire Cloth	7.000 x 7.000 x .002	15-5	CR
251-3049-00	Wire	.250 hex	15-3	CR
251-3052-00	Wire	.094 dia	15-2	CR
251-3056-00	Wire	.017 x .500	15-2	CR
251-3057-00	Wire	.017 x .750	15-2	CR
251-3060-00	Wire	.017 x 1.000	15-2	PP
251-3062-00	Strip	.017 x 2.250	15-4	PP
251-3065-00	Strip	.017 x 2.000	15-4	MP

§§ STATUS CODES

CR	Current Production
EN	Engineering
PP	Pre-Production
CS	Customer Service
NP	Non-Production
DL	Deleted
OB	Obsolete Instrument
CM	Custom Mod Instrument
DS	Digital Systems
OT	Obsolescent Instrument
MP	Modified Part
LR	Last Supply Current
LS	Last Supply Customer Service
VN	Vendor
TC	Tequipment Current Production
IN	International
SC	Sony/Tek Current Production

THE STATUS IN THIS CATALOG WAS CORRECT AT THE TIME IT WAS PUBLISHED, BUT IT IS SUBJECT TO CHANGE.

§ TO USE A PART WITH THIS STATUS ON A NEW INSTRUMENT REQUIRES THAT A NEW PURCHASED PART INITIATION FORM (PPIF) BE INITIATED.

(A GLOSSARY OF TERMS FOR THESE STATUS CODES CAN BE FOUND ON PAGE 0-10).

STAINLESS STEEL (CONT)

MECHANICAL PROPERTIES & MISC.

TYPE	TENSILE STRENGTH PSI	YIELD STRENGTH PSI	ELONGATION IN 4 X DIA (PERCENT)	HARDNESS
S30100 S30200 S30400 S30500 & S31603	75,000 min 75,000 min 75,000 min 70,000 min	(PER ASTM A 167) 30,000 min 30,000 min 30,000 min 25,000 min	40 min 40 min 40 min 40 min	
S43000	65,000 min	(PER ASTM A 176) 30,000 min	22 min	
.01 dia .02 .035	320,000-350,000 300,000-330,000 274,000-304,000	(PER ASTM A 313) 280,000-308,000		
All austenitic steels	75,000 min	(PER ASTM A 511) 30,000 min	35 min	
S30200, S30400 S31600 Cond A S43000 Cond A	90,000 min 70,000 min	(PER ASTM A 580) 45,000 min 40,000 min	35 min ¹ 16 min	
S30300, S41600 Cond A	85,000-125,000	(PER ASTM A 581) 35,000*	50*	
S30300, S41600 Cond A	75,000 min*	(PER ASTM A 582) 30,000 min*	35 min*	HBN 262 max
Cond A Cond C	130,000 220,000	(17-7 PH) 40,000 190,000	35 5	RB 85 RC 43
S30500 ³ S43000 F2	80,000 75,000	(CARPENTER) 36,000 45,000	56 20	HBN 156 HBN 150

* Values given are for comparison and are not specified in ASTM.

¹ Material .156 diameter and under in size, the elongation and reduction in area shall be 25% and 40% respectively.

² CARPENTER S43000 F is a chromium iron alloy specially developed for solenoid cores and housings which must operate in corrosive environments. For magnetic properties, contact Engineering Standards or the vendor catalog.

³ CARPENTER Type S30500 is used for severe deep drawing and spinning operations, also used where the finished part must remain nonmagnetic after severe cold working.

NO 1 FINISH - Hot rolled, annealed and pickled.
NO 2 FINISH - Very bright finish
NO 2B FINISH - Full finish (bright cold rolled).
NO 2D FINISH - Cold rolled, dull finish.
NO 4 FINISH - Standard polish; one or both sides

NO 1 EDGE - Rolled edge, either round or square as specified.

NO 3 EDGE - An edge produced by slitting.

NO 5 EDGE - Approximately square edge produced by rolling or filing after slitting.

CONDITION:

The following conditions (tempers) are available when using ASTM specifications:

Condition A (Annealed).
 Condition B (Cold Worked). Applies to wire annealed and cold worked to produce high strength in chromium-nickel types not hardenable by heat treatment.
 Condition H (Hard Temper).

STAINLESS STEEL (CONT)

TOLERANCES (PER ASTM A555)

DIAMETER AND OUT-OF-ROUND TOLERANCES FOR ROUND WIRE (DRAWN; POLISHED; CENTERLESS GROUND; CENTERLESS GROUND AND POLISHED) ^{1,2}		
SPECIFIED DIAMETER IN.	DIAMETER TOLERANCE, IN.	
	OVER	UNDER
.5000	.0020	.0020
Under .5000 to .3125 incl.	.0015	.0015
Under .3125 to .0440 incl.	.0010	.0010
Under .0440 to .0330 incl.	.0008	.0008
Under .0330 to .0240 incl.	.0005	.0005
Under .0240 to .0120 incl.	.0004	.0004
Under .0120 to .0080 incl.	.0003	.0003
Under .0080 to .0048 incl.	.0002	.0002
Under .0048 to .0030 incl.	.0001	.0001

¹The maximum out-of-round tolerance for round wire is one half of the total size tolerance given in this table.

²When it is necessary to heat treat or heat treat and pickle after cold finishing, size tolerances are double those shown above for sizes .024 in. and over.

SIZE TOLERANCES FOR DRAWN WIRE IN HEXAGON, OCTAGONS, AND SQUARES ¹		
SPECIFIED SIZE (DISTANCE ACROSS FLATS) IN.	SIZE TOLERANCE, IN.	
	OVER	UNDER
.500	0	.004
Under .500 to .312	0	.003
Under .312 to .125	0	.002

¹When it is necessary to heat treat or heat treat and pickle after cold finishing, size tolerances are double those shown above.

(PER ASTM A480)

PERMISSIBLE VARIATIONS IN THICKNESS FOR HOT-ROLLED SHEETS IN CUT LENGTHS, COLD-ROLLED SHEETS IN CUT LENGTHS AND COILS	
SPECIFIED THICKNESS ¹ , IN.	PERMISSIBLE VARIATIONS, OVER AND UNDER ²
Over .145 to less than .187	.014
Over .130 to .145 incl.	.012
Over .114 to .130 incl.	.010
Over .098 to .114 incl.	.009
Over .083 to .098 incl.	.008
Over .072 to .083 incl.	.007
Over .058 to .072 incl.	.006
Over .040 to .058 incl.	.005
Over .026 to .040 incl.	.004
Over .016 to .026 incl.	.003
Over .007 to .016 incl.	.002
Over .005 to .007 incl.	.0015
.005	.001

¹Thickness measurements are taken at least .375 in. from the edge of the sheet.

²Cold-rolled sheets in cut lengths and coils are produced in some type numbers and some widths and thicknesses to tolerances less than those shown in the table.

PERMISSIBLE VARIATIONS IN WIDTH AND LENGTH FOR HOT-ROLLED AND COLD-ROLLED RESQUARED SHEETS (STRETCHER LEVELED STANDARD OF FLATNESS)		
NOTE - Polished sheets with Finishes No. 4 and higher are produced to tolerances given in this table.		
SPECIFIED DIMENSIONS, IN.	TOLERANCES, IN.	
	OVER	UNDER
For thickness under .131		
Widths up to 48 excl.	.062	0
Widths 48 and over	.125	0
Lengths up to 120 excl.	.062	0
Lengths 120 and over	.125	0
For thicknesses .131 and over:		
All widths and lengths	.250	0

(PER ASTM A269)

PERMISSIBLE VARIATIONS IN DIMENSIONS						
GROUP	SIZE, OUTSIDE DIAMETER, IN.	PERMISSIBLE VARIATIONS IN OUTSIDE DIAM. IN. (MM)	PERMISSIBLE VARIATIONS IN WALL THICKNESS ¹ PERCENT	OVALITY SHALL BE DOUBLE THE PERMISSIBLE VARIATIONS IN OUTSIDE DIAMETER WHEN WALL THICKNESS IS:	PERMISSIBLE VARIATIONS IN CUT LENGTH, IN. (MM) ²	
					OVER	UNDER
1	Up to 1/2	±.005 (.13)	± 15		1/8 (3.2)	0
2	1/2 to 1-1/2, excl	±.005 (.13)	± 10	Less than .065 in (1.65 mm)	1/8 (3.2)	0
3	1-1/2 to 3-1/2, excl	±.010 (.25)	± 10	Less than .095 in (2.41 mm)	1/16 (4.8)	0
4	3-1/2 to 5-1/2, excl	±.015 (.38)	± 10	Less than .150 in (3.81 mm)	1/16 (4.8)	0
5	5-1/2 to 8, excl	±.030 (.76)	± 10		1/16 (4.8)	0

¹When tubes as ordered require wall thicknesses 1/4 in. (19.0 mm) or over, or an inside diameter 60 percent or less of the outside diameter, a wider variation in wall thickness is required. On such sizes a variation in wall thickness of 12.5 percent over or under will be permitted.
For tubes less than 1/2 in. (12.7 mm) in inside diameter which cannot be successfully drawn over a mandrel, the wall thickness may vary ± 15 percent from that specified.

²These tolerances apply to cut lengths up to and including 24 ft. (7.3 m). For lengths over 24 ft. an additional over tolerance of 1/8 in. (3.2 mm) for each 10 ft. (3.0 m) or fraction thereof shall be permissible, up to a maximum tolerance of 1/2 in. (12.7 mm).

TEK PART NUMBER SYSTEM INDEX PARTS & PRODUCTS STATUS CODES CATALOG PART NUMBER INDEX AND HAND TOOLS

SECTION 0

TABLE OF CONTENTS

	PAGE(S)
TEK PART NUMBER SYSTEM INDEX	0-2 THRU 0-9
ALPHABETICAL	0-2 THRU 0-5
NUMERICAL	0-6 THRU 0-9
PARTS AND PRODUCTS STATUS CODES	0-10
NOTES	0-11
HAND TOOLS	0-13 THRU 0-31
HAND TOOL CROSS-REFERENCE INDEX	0-32 & 0-33
* CATALOG PART NUMBER INDEX	0-36 THRU 0-47
CONVERSION TABLE (INCH TO MM)	0-34
EVALUATION ENGINEER LIST	0-48 THRU 0-51

* CONTAINS ALL PART NUMBERS LISTED IN THIS CATALOG. EACH SECTION ALSO HAS ITS OWN INDEX WHICH INCLUDES THE STATUS OF EACH PART.

TEK PART NUMBER SYSTEM

ALPHABETICAL

THIS IS NOT THE INDEX TO THIS CATALOG BUT TO THE TEK PN SYSTEM IN GENERAL

TYPE OF PARTS	CATEGORY	TYPE OF PARTS	CATEGORY
ACCESSORIES - SEE PROBE, CABLE OR SPECIFIC PART		CABINET AND CABINET SUBASSEMBLY	437-0000-00
ACCESSORIES (SPECTROMETER)	016-1000-00	CABINET PARTS (SIDES, TOPS, ETC.)	{ 390-0000-00 (new) and 386-0000-00 (old) and 387-0000-00 (old)
ACCESSORY PACKAGE (INSTRUMENT)	020-0000-00		
ACTUATOR ASSEMBLY, CAM SWITCH	263-1000-00	CABINET WRAPAROUND (INSTRUMENT TYPE)	390-0000-00
ACTUATOR (GENERAL)	214-0000-00	CABLE (BULK) & CABLE ASSEMBLY	{ 175-0000-00 and 175-0499-00 and 175-1000-00
ACTUATOR, CAMERA (ACCESSORY)	016-0200-00		
ADAPTER (GENERAL PARTS, NOT ACCESSORY)	103-0000-00	CABLE ASSEMBLY (ACCESSORY)	012-0000-00
ADAPTER, CAMERA (ACCESSORY)	016-0200-00	CABLE ASSEMBLY, GR (ASSEMBLY)	017-0500-00
ADAPTER, ELECTRICAL (ACCESSORY)	013-0000-00	CABLE ASSEMBLY, PROBE	{ 175-0000-00 and 175-1000-00
ADAPTER, GR CONNECTOR (ACCESSORY)	017-0000-00		
ADAPTER, INSTRUMENT (ACCESSORY)	015-0000-00	CABLE HARNESS (SEE WIRING HARNESS)	
ADAPTER, MECHANICAL (ACCESSORY)	014-0000-00	CABLE, ELECTRODE ADAPTER (ACCESSORY)	012-0000-00
ADAPTER, PROBE (ACCESSORY)	015-0000-00	CABLE, INTERCONNECTING (ACCESSORY)	012-0000-00
ADAPTER, RACK MOUNT (ACCESSORY)	016-0000-00	CABLE, POWER (PROCESSED)	161-0000-00
ADHESIVE	006-0000-00	CABLE, NIPPLE	200-0000-00
ALUMINUM	{ 251-0000-00 and 251-1000-00	CALIBRATION FIXTURES	067-0000-00
		CAM	401-0000-00
ANGLES (SEE ALSO FRAME AND FRAME SECTIONS)	122-0000-00	CAM SWITCH ACTUATOR ASSEMBLY (SEE ACTUATOR ASSEMBLY, CAM SWITCH)	
ANVIL (SOLENOID, ETC.)	119-0000-00	CAMERA PARTS & ASSEMBLIES (PURCHASED)	122-0500-00
ATTENUATION HEAD, PROBE (ACCESSORY)	010-0000-00	CAMERA ACCESSORIES	016-0200-00
ATTENUATOR, FIXED AND VARIABLE (ACCESSORY)	011-0000-00	CAN	202-0000-00
ATTENUATOR, 3mm (ACCESSORY)	015-1000-00	CAP	200-0000-00
ATTENUATOR, GR (ACCESSORY)	017-0000-00	CAPACITOR, CHECKED, ETC.	295-0000-00
ATTENUATOR STRIP, DUMMY	124-0000-00	CAPACITOR, COUPLING (ACCESSORY)	011-0000-00
ATTENUATOR, TURRET SWITCH	263-0000-00	CAPACITOR, FIXED CERAMIC DIELECTRIC	281-0500-00
ATTENUATOR, PROBE HEAD (ACCESSORY)	010-0300-00	CAPACITOR, FIXED CERAMIC DIELECTRIC (DISC TYPE)	283-0000-00
		CAPACITOR, FIXED, ELECTROLYTIC	290-0000-00
BAFFLE, AIR	378-0750-00	CAPACITOR, FIXED (GLASS & PORCELAIN DIELECTRIC)	285-0000-00
BANANA JACK (SEE JACK OR PLUG)		CAPACITOR, FIXED, MICA DIELECTRIC	283-0500-00
BAND (MARKING)	334-0000-00	CAPACITOR, FIXED (PLASTIC & PAPER DIELECTRIC)	285-0500-00
BAR (OTHER THAN BULK)	381-0000-00	CAPACITOR, FIXED, PLASTIC (TEK-MADE)	291-0000-00
BASE	432-0000-00	CAPACITOR, VARIABLE	281-0000-00
BATTERY	146-0000-00	CAPACITOR WINDINGS (TEK-MADE)	291-0200-00
BEARING	401-0000-00	CAPACITORS, MATCHED	295-0000-00
BELTS (PULLEY, POSITIVE DRIVE, ETC.)	214-0000-00	CARTON (SHIPPING)	004-0000-00
BEZEL (ACCESSORY)	014-0000-00	CARTS (OSCILLOSCOPE)	016-0000-00
BEZEL	200-0000-00	CASE	202-0000-00
BINDER, LOAD	214-0000-00	CASE, CARRYING	016-0000-00
BLADDER	{ 214-0000-00 and 341-0000-00	CASE, TRANSISTOR	202-0000-00
		CASTER	401-0000-00
BLADE, SHUTTER	122-0000-00	CATCH	105-0000-00
BLOCK	391-0000-00	CATHODE RAY TUBE	154-0000-00
BOARD, CIRCUIT (SEE CIRCUIT BOARD)		CERAMIC MATERIAL (BULK)	256-0000-00
BOARD, TERMINAL (SEE TERMINAL BOARD)		CERAMIC STRIP (SEE TERMINAL STRIP, CERAMIC)	
BODY AND BODY HALF	204-0000-00	CHAIN	214-0000-00
BOLT	214-0000-00	CHASSIS	441-0000-00
BOX	202-0000-00	CHASSIS-TRACK (SEE SLIDE, RM AND GUIDE, RM)	
BRACE	122-0000-00	CHOPPER	119-0000-00
BRACKET	{ 406-0000-00 and 407-0000-00	CIRCUIT BOARD (UNWIRED)	388-0500-00
		CIRCUIT BOARD (2 or MORE 670-)	672-0000-00
BRASS (BULK)	{ 251-0300-00 and 258-0300-00	CIRCUIT BOARD ASSEMBLY (WIRED)	670-0000-00
		CIRCUIT BOARD ASSEMBLY	{ 675-0000-00 and 700-0000-00
BRONZE (BULK)	{ 251-0300-00 and 258-0300-00		
		CIRCUIT BOARD KITS	675-0000-00
BRUSH, MOTOR	147-0200-00	CIRCUIT BOARD SUBASSEMBLY	{ 673-0000-00 and 678-0000-00
BULB (SEE LAMP)			
BUMPER	348-0000-00	CIRCUIT BREAKER	260-0000-00
BUSHING	358-0000-00		
BUTTON, PLUG	134-0000-00		

TEK PART NUMBER SYSTEM (CONT)

ALPHABETICAL

0

THIS IS NOT THE INDEX TO THIS CATALOG BUT TO THE PN SYSTEM IN GENERAL

TYPE OF PARTS	CATEGORY	TYPE OF PARTS	CATEGORY
CIRCUIT CARD (ACCESSORY)	018-0000-00	FILM, IDENTIFICATION	334-0000-00
CLAMP	343-0000-00	FILTER, AIR	378-0000-00
CLIP	344-0000-00	FILTER (ELECTRONIC)	119-0000-00
CMS CARTON PACKAGES	065-0000-00	FILTER, LIGHT	378-0500-00
COIL, FIXED	108-0000-00	FILTER, MESH, CRT	378-0500-00
COIL, FIXED, REED SWITCH	108-0000-00	FLANGE	386-0000-00
COIL, VARIABLE	114-0000-00	FLIP-STAND, CABINET	348-0000-00
COLLAR	{ 343-0000-00 (new) and 214-0000-00 (old)	FOIL	251-1000-00
COLUMN	426-0000-00	FOOT	348-0000-00
COMPENSATOR (ACCESSORY)	011-0000-00	FORM, COIL (SEE ALSO CORE)	276-0000-00
CONDUCTOR, SINGLE (INSULATED)	175-5000-00	FRAME AND FRAME SECTIONS	426-0000-00
CONNECTOR (GENERAL)	131-0000-00	FRAME, MOUNTING (ACCESSORY)	014-0000-00
CONNECTOR (GR AND ASSOCIATED GR SUBPARTS)	132-0000-00	FRAME-PANEL, CABINET (FRONT, REAR, ETC.)	426-0000-00
CONTACT	{ 131-0000-00 (new) and 214-0000-00 (old)	FURNITURE	007-0000-00
COPPER (BULK)	{ 251-0300-00 and 258-0300-00	FUSE	159-0000-00
CORD, LACING	253-0000-00	GASKET	{ 214-0000-00 (old) and 348-0000-00 (new)
CORD, POWER (SEE CABLE, POWER)		GEARS	{ 214-0000-00 (old) and 401-0000-00 (new)
CORE (TRANSFORMER, COIL, FERRITE, ETC.)	276-0500-00	GEAR BACK	214-0000-00
COUNTER	331-0000-00	GEAR STOCK (BULK) SEE ROD, PINION	
COUPLING AND COUPLER	376-0000-00	GRATICULE	331-0000-00
COVER	200-0000-00	GRILLE (FAN, ETC.)	378-0750-00
COVER, PROTECTIVE (OSCP)	016-0000-00	GRIP	367-0000-00
CRADLE	426-0000-00	GROMMET	348-0000-00
CRT'S (SALEABLE)	154-0000-00	GUARD	200-0000-00
CRT MATERIAL	{ 439-0000-00 and 440-0000-00	GUIDE	351-0000-00
CRT MESH FILTER (SEE FILTER, MESH, CRT)		GUIDE, RM (SEE ALSO SLIDE, RM)	351-0000-00
CRYSTAL UNITS	158-0000-00	HAND TOOLS	003-0000-00
CUP	201-0000-00	HANDLE	367-0000-00
CUSHION	348-0000-00	HARDWARE KIT	016-0000-00
CUSTOM ENGINEERING PARTS	{ 030-0000-00 to 038-0000-00	HARDWARE (SEE WASHER, TERMINAL, NUT, SCREW OR SPECIFIC ITEM)	214-0000-00
DELAY LINE (COAX CABLE TYPE & ACCESSORY)	015-1000-00	HARNESS, WIRING (SEE WIRING HARNESS)	
DELAY LINE	119-0000-00	HEADER	131-0000-00
DETENT, CAM SWITCH	214-0000-00	HEAT SINK	214-0000-00
DIAL	331-0000-00	HINGE	214-0000-00
DIODE (SEE SEMICONDUCTOR DEVICE, DIODE)		HOLDER	352-0000-00
DISK OR DISC	214-0000-00	HOLDER, LAMP (WITHOUT ELECTRICAL CONTACTS. USE LAMPHOLDER IF CONTACTS INCLUDED)	352-0000-00
DOOR	200-0000-00	HOOD, VIEWING (ACCESSORY, SEE VIEWING HOOD)	
DRAWER	436-0000-00	HOUSING	380-0000-00
DRUM	105-0000-00	HUB	401-0000-00
DRUM, CAM SWITCH	105-0000-00	HYBRID CIRCUIT (TEK-MADE)	155-0000-00
ELECTRON TUBES (CHECKED, ETC.)	157-0000-00	IDENTIFICATION ITEMS	334-0000-00
ELECTRON TUBES (INCLUDING CRT)	154-0000-00	IMPELLER (AIR FAN)	369-0000-00
ETCH CIRCUIT BOARD/CARD (SEE CIRCUIT BOARD/CARD)		INSERT	377-0000-00
EXTENDER (ACCESSORY TYPE)	013-0000-00	INSERT, SCREW THREAD	377-0000-00
EXTENSION SHAFT (SEE SHAFT, EXTENSION)		INSULATION SLEEVING (HI-TEMP, SHRINK, ETC.)	162-0500-00
EYELET	210-0600-00	INSULATION, SLEEVING (PLAIN)	162-0000-00
FAN	119-0000-00	INSULATOR	{ 342-0000-00 (new) and 214-0000-00 (old)
FASTENERS (SEE ALSO SCREW, NUT, LATCH, CATCH, ETC)	214-0000-00	INTEGRATED CIRCUITS (PURCHASED)	{ 156-0000-00 and 160-0000-00
FELT (BULK)	252-0500-00	INTEGRATED CIRCUITS (TEK-MADE)	155-0000-00
FERRULE	166-0000-00	INTERFACE UNITS	021-0000-00
FIBER OPTIC, BULK (SEE LIGHT CONDUCTOR)		JACK (TELEPHONE OR TIP)	131-0000-00
FILM, IDENTIFICATION	334-0000-00		

TEK PART NUMBER SYSTEM (CONT)

ALPHABETICAL

THIS IS NOT THE INDEX TO THIS CATALOG BUT TO THE TEK PN SYSTEM IN GENERAL

TYPE OF PARTS	CATEGORY	TYPE OF PARTS	CATEGORY
KEY (CONNECTOR AND LOCK)	214-0000-00	OSCILLATORS	119-0000-00
KITS, COMBINATION ASSEMBLIES	644-0000-00	OSCILLOSCOPE CART	016-0000-00
KITS, CRT SHIELD	626-0000-00		
KITS, DELAY LINE	636-0000-00	PAD	348-0000-00
KITS, FAN MOTOR	635-0000-00	PAINT (BULK)	252-0000-00
KITS, F & I	624-0000-00	PANEL (ETCH & ANODIZED) (FRONT, REAR, ETC.)	333-0000-00
KITS, FINAL	602-0000-00	PANEL (NOT ANODIZED) (REAR, SUB-, ETC.)	{ 386-0000-00
KITS, FRAME PLATE	630-0000-00	PAPER (BULK)	{ 387-0000-00
KITS, HIGH VOLTAGE POWER	621-0000-00	PARTITION	252-0500-00
KITS, LOW VOLTAGE POWER	620-0000-00	PART REPLACEMENT KITS	386-0000-00
KITS, MISCELLANEOUS	650-0000-00	PHOTO COMPONENTS	050-0000-00
KITS, MISCELLANEOUS AMPLIFIER CHASSIS	616-0000-00	PIGMENT, PLASTIC MOLDING MATERIAL	122-0500-00
KITS, MISCELLANEOUS CHASSIS	610-0000-00	PIN, CONNECTING (SEE TERMINAL PIN)	255-0000-00
KITS, MISCELLANEOUS PLATES	631-0000-00	PIN	214-0000-00
KITS, MISCELLANEOUS SHIELD	627-0000-00	PINION ROD (SEE ROD, PINION)	
KITS, MISCELLANEOUS SIGNAL & TRIGGER	660-0000-00	PIVOT ART	367-0000-00
KITS, MODIFICATION (CS)	040-0000-00	PLASTIC SHEET AND STRIP, ROD, MOLDING MATERIAL (ALL BULK)	{ 254-0500-00
KITS, MODULAR	655-0000-00	PLATE (IDENTIFICATION AND INSTRUCTIONS)	{ and 255-0000-00
KITS, MOUNTING BRACKET	640-0000-00	PLATE (MISCELLANEOUS)	{ 334-0000-00
KITS, PARTS REPLACEMENT (CS)	050-0000-00	PLUG (TELEPHONE OR TIP)	{ and 386-0000-00
KITS, PLUG-IN HOUSING	634-0000-00	PLUNGER, SOLENOID	{ and 387-0000-00
KITS, POWER PLUG & SOCKETS	643-0000-00	POINTER	134-0000-00
KITS, RECTIFIER BRACKET	637-0000-00	POST (ELECTRICAL AND MECHANICAL)	119-0000-00
KITS, SHIPPING	608-0000-00	POT (SEE RESISTOR, VARIABLE)	016-0000-00
KITS, SPECIAL EXCHANGE	046-0000-00	POWER SUPPLY (HV) INTERNAL INST. COMPONENT	257-0000-00
KITS, SPECIAL REPLACEMENT	045-0000-00	POWER SUPPLY (ACCESSORY)	000-0000-00
KITS, SUBPANEL	614-0000-00	PRECIOUS METALS	010-0000-00
KITS, SWEEP, DELAY SWEEP	619-0000-00	PRINTED MATTER	010-0300-00
KITS, TEST	606-0000-00	PROBE	010-0000-00
KITS, TUBE	604-0000-00	PROBE HEADS	010-0000-00
KITS, VERTICAL AMPLIFIER	615-0000-00	PROBE PACKAGE	
KNOB	366-0000-00	PULLEY (SEE ALSO SPROCKET WHEEL)	{ 214-0000-00 (old)
KNOB-DIAL ASSEMBLY	366-0500-00	PUSHBUTTON/PUSHBUTTON ASSEMBLY	{ and 401-0000-00 (new)
KNOB SKIRT (SEE RING, KNOB SKIRT)			336-0000-00
		RACK	405-0000-00
LABELS (IDENTIFICATION)	334-0000-00	RAIL	122-0000-00
LAMPS & LIGHTS	150-0000-00	RECEPTACLE (CONNECTOR)	131-0000-00
LAMP, LED (LIGHT EMITTING DIODES)	150-1000-00	RECEPTACLE (MECHANICAL ONLY)	136-0000-00
LAMP, LED (LIGHT EMITTING DIODES)	150-1000-00	RECTIFIER (SELENIUM)	106-0000-00
LEAD, SINGLE CONDUCTOR (INSULATED)	175-5000-00	RECTIFIER (SEMICONDUCTOR, GENERAL)	152-0000-00
LEADS (FORMED, SETS, SPL PATTERNS, ETC.)	195-0000-00	RECTIFIER (SEMICONDUCTOR, SELECTED, ETC.)	153-0000-00
LEADS (FORMED, SETS, SPL PATTERNS, ETC.)	195-0000-00	REDUCER	102-0000-00
LIGHT CONDUCTOR	253-0000-00	REFLECTOR	378-0500-00
LINOLEUM	252-0500-00	RELAY	148-0000-00
		RELAY COMPONENTS (TEK-MADE)	148-3000-00
MANUAL, TECHNICAL	070-0000-00	RELAY, MAGNETIC REED (SEE ALSO SWITCH, MAG REED)	148-0000-00
METER	149-0000-00	REPLACEMENT PARTS FOR PURCHASING ASSEMBLIES	118-0000-00
MICROCIRCUIT (TEK-MADE)	155-0000-00	RESILIENT MOUNT	384-0000-00
MICROCIRCUIT (PURCHASED)	156-0000-00	RESISTOR (ATTENUATOR STRIPS)	307-1000-00
MICROCIRCUIT (PROGRAMMABLE MEMORIES)	160-0000-00	RESISTOR, FIXED, FILM (CARBON 0.5W)	309-0000-00
MOTORS	147-0000-00	RESISTOR, FIXED, FILM (CARBON 1.0W)	310-0000-00
		RESISTOR, FIXED, FILM (CARBON 1.0W)	310-0500-00
NOSE, PROBE	206-0000-00	RESISTOR, FIXED, FILM (CARBON 0.125W, 1%)	318-0000-00
NUT	{ 220-0400-00	RESISTOR, FIXED, COMP. (0.125W, 5%)	317-0000-00
	{ and 210-0400-00	RESISTOR, FIXED, FILM (CARBON 0.25W, BELOW 5%)	319-0000-00
NUT BAR	220-0400-00	RESISTOR, FIXED, COMP. (0.25W, 5%)	315-0000-00
OFFICE SUPPLIES	002-0000-00		
OPERATING SUPPLIES	006-0000-00		
OPTIC COMPONENTS	122-0500-00		

TEK PART NUMBER SYSTEM (CONT)

ALPHABETICAL

0

THIS IS NOT THE INDEX TO THIS CATALOG BUT TO THE TEK PN SYSTEM IN GENERAL

TYPE OF PARTS	CATEGORY
RESISTOR, FIXED, COMP. (0.25W, 10%)	316-0000-00
RESISTOR, FIXED, COMP. (0.5W, 5%)	301-0000-00
RESISTOR, FIXED, COMP. (0.5W, 10%)	302-0000-00
RESISTOR, FIXED, COMP. (1.0W, 5%)	303-0000-00
RESISTOR, FIXED, COMP. (1.0W, 10%)	304-0000-00
RESISTOR, FIXED, COMP. (2.0W, 5%)	305-0000-00
RESISTOR, FIXED, COMP. (2.0W, 10%)	306-0000-00
RESISTOR, FIXED, HV (SEE 307-)	314-0000-00
RESISTOR - KNOB, MATCHED	312-0100-00
RESISTOR (FIXED-MATCHED, SELECTED, SETS, ETC AT TEK)	312-0500-00
RESISTOR, FIXED, FILM (METAL FILM 0.125W, 1% OR LESS, STANDARD RES. VALUES)	321-0000-00
RESISTOR, FIXED, FILM (METAL FILM 0.125W, 1% OR LESS, SPECIAL VALUES)	321-0600-00
RESISTOR, FIXED, FILM (METAL FILM 0.125W, 1% OR LESS, STANDARD RES. VALUES)	321-1000-00
RESISTOR, FIXED, FILM (METAL FILM 0.25W, 1% OR LESS, STANDARD RES. VALUES)	322-0000-00
RESISTOR, FIXED, FILM (METAL FILM 0.25W, 1% OR LESS, SPECIAL VALUES)	322-0600-00
RESISTOR, FIXED, FILM (METAL FILM 0.25W, 1% OR LESS, STANDARD RES. VALUES)	322-1000-00
RESISTOR, FIXED, FILM (METAL FILM 0.5W, 1% OR LESS, STANDARD RES. VALUES)	323-0000-00
RESISTOR, FIXED, FILM (METAL FILM 0.5W, 1% OR LESS, SPECIAL VALUES)	323-0600-00
RESISTOR, FIXED, FILM (METAL FILM 0.5W, 1% OR LESS, STANDARD RES. VALUES)	323-1000-00
RESISTOR, FIXED, FILM (METAL FILM 1.0W, 1% OR LESS, STANDARD RES. VALUES)	324-0000-00
RESISTOR, FIXED, FILM (METAL FILM, 1.0W, 1% OR LESS, SPECIAL VALUES)	324-0600-00
RESISTOR, FIXED, FILM (METAL FILM 1.0W, BELOW 1%, STANDARD RES. VALUES)	324-1000-00
RESISTOR, FIXED, FILM (METAL FILM-MISC. NOT FITTING IN 321- THRU 324- CATEGORIES)	325-0000-00
RESISTOR, FIXED, FILM (ALL FILM NOT FITTING IN ANY PRECEDING CATEGORIES)	307-0000-00
RESISTOR, FIXED, FOIL	307-0000-00
RESISTOR, FIXED, THICK FILM	307-0000-00
RESISTOR, FIXED, WIREWOUND	308-0000-00
RESISTOR, VARIABLE	311-0000-00
RESISTOR, VARIABLE (SELECTED FROM 311- RES.)	312-0000-00
RETAINER	343-0000-00
RING	354-0000-00
RING, KNOB SKIRT	354-0000-00
RING, RETAINING	354-0000-00
RING, TRIM	354-0000-00
RIVET	210-0600-00
ROD (MISCELLANEOUS)	385-0000-00
ROD, PINION	251-1000-00
ROTATING MECHANICAL PARTS	401-0000-00
ROTOR, VARIABLE RESISTOR	401-0000-00
RUBBER (BULK)	252-0500-00
SCALE	331-0000-00
SCREEN	378-0750-00
SCREW (UP THRU 5-40)	211-0000-00
SCREW (6-32 AND SMALLER)	211-0500-00
SCREW (8-32)	212-0000-00
SCREW (10-24, 10-32, 12-24 & 12-32)	212-0500-00
SCREW (ABOVE 12-32 & TAPPING, SETSCREWS, ETC.)	213-0000-00
SEMICONDUCTOR DEVICE, DIODE	152-0000-00

TYPE OF PARTS	CATEGORY
SEMICONDUCTOR DEVICE, DIODE (CHECKED, ETC.)	153-0000-00
SETSCREW	213-0000-00
SHAFT, EXTENSION & SPACING	384-0000-00
SHAFT (OTHER)	384-0500-00
SHEET, NON-METALLIC (PAPER, FELT, LINOLEUM, PLASTIC)	107-0000-00
SHELF	436-0000-00
SHELL (GENERAL)	205-0000-00
SHELL, KNOB	366-0000-00
SHIELD (ELECTRICAL AND MECHANICAL)	337-0000-00
SHIELD, IMPLSION	337-0000-00
SHIELDING GASKET, ELECTRICAL	348-0000-00
SHIM	361-0000-00
SHIPPING SUPPLIES	004-0000-00
SHOCKMOUNT	348-0000-00
SHUTTER (CAMERA)	122-0500-00
SILICON WAFERS	203-0000-00
SLEEVE (MARKING)	334-0000-00
SLEEVE, SPACER	361-0000-00
SLIDE	351-0000-00
SLIDE, RM	351-0000-00
SLIDE, GUIDE, RM (ASSEMBLY)	361-0000-00
SLUG (CORE)	276-0000-00
SOCKET	136-0000-00
SOLDER (BULK)	251-0500-00
SOLDER LUG (SEE TERMINAL, LUG)	
SOLENOID	119-0000-00
SPACER (THREADED)	129-0000-00
SPACER (UNTHREADED)	361-0000-00
SPARES LISTS, INTERNATIONAL	060-0000-00
SPECIAL PRINTED ITEMS	061-0000-00
SPRING	214-0000-00
SPROCKET WHEEL	401-0000-00
STAINLESS STEEL (BULK)	251-0500-00
STANDARDIZERS (ACCESSORY)	011-0000-00
STEEL (BULK)	251-0500-00
STEM	355-0500-00
STIFFENER	386-0000-00
STOP	105-0000-00
STRAIN RELIEF (SEE BUSHING)	358-0000-00
STRAP	346-0000-00
STRIKE	105-0000-00
STRIP (CERAMIC TRIM, FELT, TRIM METAL, RUBBER, ETC.)	124-0000-00
STUD	355-0000-00
SUBPANEL	386-0000-00 and 387-0000-00
SUBSTRATE	204-0000-00
SUPPORT	386-0000-00 and 387-0000-00
SWITCH, PURCHASED	260-0000-00
SWITCH, MAGNETIC REED	260-0000-00
SWITCH (WIRED)	262-0000-00
SWITCHES, TEK-MADE, OTHER THAN CAM (OPTICAL, MBS PANCAKE AND TURRET)	263-0000-00
SWITCH ASSEMBLY, TEK-MADE, OTHER THAN CAM (OPTICAL MBS, PANCAKE AND TURRET)	263-0000-00
SWITCHES, TEK-MADE, CAM	263-1000-00
SWITCH ASSEMBLY, TEK-MADE, CAM	263-1000-00
SYSTEM PARTS	039-0000-00

TEK PART NUMBER SYSTEM (CONT)

ALPHABETICAL

THIS IS NOT THE INDEX TO THIS CATALOG BUT TO THE TEK PN SYSTEM IN GENERAL

TYPE OF PARTS	CATEGORY
TAG	334-0500-00
TANK	202-0000-00
TAPE (PUNCHED OR MAGNETIC PROGRAM)	016-0000-00
TAPE	253-0000-00
TERMINAL (ELECTRICAL)	131-0000-00
TERMINAL, BLADE	131-0000-00
TERMINAL BOARD	392-0000-00
TERMINAL, LUG	210-0200-00
TERMINAL, PIN	131-0000-00
TERMINAL STRIP, CERAMIC	{ 123-0000-00 and 124-0000-00
TERMINAL STRIP (OTHER)	124-0000-00
TERMINAL, STUD	131-0000-00
TERMINATION (ACCESSORY GENERAL)	011-0000-00
TERMINATION (ACCESSORY 3mm)	015-1000-00
TERMINATION (ACCESSORY GR)	017-0000-00
THREAD	253-0000-00
THUMBSCREW	{ 213-0000-00 (new) and 214-0000-00 (old)
TIE PLATE (CABINET, ETC.)	344-0000-00
TIE STRIP (CIRCUIT BOARD, ETC.)	344-0000-00
TIN (BULK)	251-0500-00
TIP, PROBE (ALL EXCEPT BELOW)	206-0000-00
TIP, PROBE (REMOVABLE, RETRACTABLE ONLY)	013-0000-00
TRAINING AID (VIDEO)	068-0000-00
TRAINING CLASS	068-9000-00
TRANSISTOR (CHECKED)	153-0500-00
TRANSISTOR (FIELD EFFECT)	151-1000-00
TRANSISTOR (GENERAL)	{ 151-000-000 and 151-0600-00
TRANSISTORS, MATCHED	153-0500-00
TRANSISTORS (SPECIAL)	151-0500-00
TRANSFORMER	120-0000-00
TRAY	436-0000-00
TRIM	101-0000-00
TUBE, SPACER	
TUBE, VACUUM (CHECKED, ETC., SEE ELECTRON TUBE)	
TUBES, VACUUM AND CRT (SEE ELECTRON TUBE & CRT)	166-0000-00
TUBING, INSULATION (SEE INSULATION SLEEVING)	
TURRET SWITCH (SEE SWITCH, TURRET)	
VALVE	{ 214-0000-00 (new) and 341-0000-00 (old)
VARNISH (BULK)	252-0000-00
VIEWING HOOD, CRT (ACCESSORY)	016-0000-00
WASHER (OTHER THAN LOCK)	210-0800-00
WASHER, LOCK	210-0000-00
WHEEL	401-0000-00
WINDOW	331-0000-00
WIRE, ELECTRICAL (BULK-BARE)	176-0000-00
WIRE, ELECTRICAL (BULK-INSULATED)	175-0500-00
WIRE (BULK-COLOR CODED)	177-0000-00
WIRE SET (ELECTRICAL)	198-0000-00
WIRE SWITCHED (SEE SWITCH ASSEMBLY)	
WIRING HARNESS	179-0000-00

TEK PART NUMBER SYSTEM (CONT)

NUMERICAL

0

THIS IS NOT THE INDEX TO THIS CATALOG, BUT TO THE TEK PN SYSTEM IN GENERAL

CATEGORY	TYPE OF PARTS
000-0000-00	PRINTED MATTER
002-0000-00	OFFICE SUPPLIES
003-0000-00	HAND TOOLS
004-0000-00	SHIPPING SUPPLIES
006-0000-00	OPERATING SUPPLIES
007-0000-00	FURNITURE
010-0000-00	ACCESSORIES (PROBES & PROBE PACKAGES)
010-0300-00	ACCESSORIES (PROBE HEADS, ATTENUATOR HEADS)
011-0000-00	ACCESSORIES (TERMINATIONS, ATTENUATORS, STANDARDIZERS, UHF & BNC)
012-0000-00	ACCESSORIES (CABLE ASSEMBLY & LEADS)
013-0000-00	ACCESSORIES (CONNECTING, ADAPTING & EXTENDING UNITS NOT CABLES)
014-0000-00	ACCESSORIES (MECH: MOUNTING, FRAMES, BEZELS, ADAPTERS, ETC.)
015-0000-00	ACCESSORIES (ELEC: PROBE & INST. ADAPTER UNITS)
015-1000-00	ACCESSORIES (TERMINATIONS, ATTENUATORS, ETC., WITH 3mm CONNECTORS)
016-0000-00	ACCESSORIES (MISC: OSP CARTS, CARRY CASES, VIEWING HOODS, TAPES, RACK ADAPTERS, INSTRUMENT PROTECTIVE COVERS, POWER SUPPLY, CAMERA ADAPT, ACTUATORS, ETC.)
016-1000-00	ACCESSORIES (SPECTROMETER)
017-0000-00	ACCESSORIES (TERMINATIONS, ATTENUATORS, ADAPTERS, ETC., WITH GR CONNECTORS)
017-0500-00	ACCESSORIES (GR TERMINATED CABLES)
018-0000-00	ACCESSORIES (SALEABLE CIRCUIT CARDS)
020-0000-00	INSTRUMENT ACCESSORY PACKAGE
021-0000-00	INTERFACE UNITS
030-0000-00 038-0000-00	to } CUSTOM ENGINEERING PARTS
039-0000-00	SYSTEM PARTS
040-0000-00	MODIFICATION KITS (CS)
045-0000-00	SPECIAL REPLACEMENT KITS
046-0000-00	SPECIAL EXCHANGE KITS
050-0000-00	PARTS REPLACEMENT KITS (CS)
060-0000-00	SPARES LISTS, INTL.
061-0000-00	SPECIAL PRINTED ITEMS
062-0000-00	SPECIAL PRINTED ITEMS, TECHNICAL DATA SHEETS
065-0000-00	CMS CARTON PACKAGES
067-0000-00	CALIBRATION FIXTURE
068-0000-00	TRAINING AID (VIDEO)
068-9000-00	TRAINING CLASS
070-0000-00	MANUAL, TECHNICAL
101-0000-00	TRIM (SEE ALSO 124- & 107-)
102-0000-00	REDUCERS
103-0000-00	ADAPTERS
105-0000-00	CATCH, LATCH, LOCK, STOP, DRUM, ETC.
106-0000-00	RECTIFIERS (SELENIUM)

CATEGORY	TYPE OF PARTS
107-0000-00	NON-METALLIC SHEETS (PAPER, FELT, LINOLEUM, PLASTIC, ETC., NOT BULK, SEE 252-0500-00)
108-0000-00	COILS (FIXED)
114-0000-00	COILS (VARIABLE)
118-0000-00	REPLACEMENT PARTS FOR PURCHASING ASSEMBLIES
119-0000-00	MISC. ELECTRICAL COMPONENTS (DELAY LINE, FILTER, CHOPPER, OSCILLATOR, POWER SUPPLY, FAN, ETC.)
120-0000-00	TRANSFORMERS (FIXED & VARIABLE)
122-0000-00	ANGLES & RAILS (STRUCTURAL -- SEE ALSO 426-)
122-0500-00	PHOTO & OPTIC COMPONENTS (CAMERA)
123-0000-00	TERMINAL STRIP, CERAMIC (TURRET)
124-0000-00	STRIPS (CERAMIC TERMINAL, PAPER, FELT, TRIM, METAL, RUBBER, ATTENUATOR, ETC.)
129-0000-00	POSTS (ELECTRICAL & MECHANICAL)
131-0000-00	CONNECTORS, CONTACTS, TERMINALS, HEADERS, ETC. (SEE ALSO 134- & 136-)
132-0000-00	GR CONNECTORS & PARTS
134-0000-00	PLUGS (SEE ALSO 131- & 136-)
136-0000-00	SOCKET, LAMPHOLDER (W/CONTACTS) & LIGHT, INDICATOR (SEE ALSO 131- & 134-)
146-0000-00	BATTERY
147-0000-00	MOTORS
147-0200-00	MOTOR BRUSHES
148-0000-00	RELAYS (INCLUDING MAGNETIC REED)
148-3000-00	COMPONENTS FOR TEK-MADE RELAYS
149-0000-00	METERS
150-0000-00	LAMPS & LIGHTS (INCLUDING LAMP, CARTRIDGE: GLOW & INCANDESCENT)
150-1000-00	LAMP, LED (LIGHT EMITTING DIODES)
151-0000-00	TRANSISTORS (GENERAL)
151-0500-00	TRANSISTORS (SPECIAL)
151-0600-00	TRANSISTORS (GENERAL)
151-1000-00	TRANSISTORS (FIELD EFFECT)
152-0000-00	DIODES
153-0000-00	DIODES (MATCHED, SELECTED, SETS, ETC. FROM 152- DIODES)
153-0500-00	TRANSISTORS (MATCHES, SELECTED, SETS, ETC. FROM 151- TRANSISTORS)
154-0000-00	ELECTRON TUBES (VACUUM & CRT)
155-0000-00	MICROCIRCUIT (TEK-MADE)
156-0000-00	MICROCIRCUIT (PURCHASED)
157-0000-00	ELECTRON TUBES (MATCHED, SELECTED, SETS, ETC. FROM 154- TUBES)
158-0000-00	CRYSTAL UNITS
159-0000-00	FUSES
160-0000-00	MICROCIRCUIT (PROGRAMMABLE MEMORIES)
161-0000-00	CABLES (POWER-BULK & PROCESSED)
162-0000-00	INSULATION SLEEVING (PLAIN)
162-0500-00	INSULATION SLEEVING (HI TEMP, HEAT SHRINK, ETC.)

TEK PART NUMBER SYSTEM (CONT)

NUMERICAL

THIS IS NOT THE INDEX TO THIS CATALOG, BUT TO THE TEK PN SYSTEM IN GENERAL

CATEGORY	TYPE OF PARTS
166-0000-00	TUBES, SLEEVES & FERRULES (MECHANICAL)
175-0000-00 to 175-0499-00 and 175-1000-00 up	CABLES (BULK & PROCESSED)
175-0500-00	WIRE & LEADS (INSULATED)
175-5000-00	SINGLE CONDUCTOR (INSULATED) (SEE ALSO LEADS)
176-0000-00	WIRE & LEADS (BARE)
177-0000-00	WIRE, ELECTRICAL: BULK (COLOR CODED)
179-0000-00	WIRING HARNESS
195-0000-00	LEADS (FORMED, SETS, SPL PATTERNS, ETC.)
198-0000-00	WIRE SET, ELECTRICAL
200-0000-00	COVERS, CAPS, BEZELS, CABLE NIPPLES, DOORS, ETC.
201-0000-00	CUPS
202-0000-00	CANS, BOXES, CASES, ETC.
203-0000-00	SILICON WAFERS
204-0000-00	BODY, BODY HALF & SUBSTRATE
205-0000-00	SHELLS & SHELL HALVES
206-0000-00	NOSES & TIPS (PROBES)
210-0000-00	LOCK WASHERS
210-0200-00	LUG TERMINALS
210-0400-00	NUTS
210-0600-00	EYELETS & RIVETS
210-0800-00	WASHERS (NOT LOCK TYPE)
211-0000-00	SCREWS (UP THRU 5-40)
211-0500-00	SCREWS (6-32 & SMALLER)
212-0000-00	SCREWS (8-32)
212-0500-00	SCREWS (10-24, 10-32, 12-24 & 12-32)
213-0000-00	SCREWS (ABOVE 12-32 & TAPPING SETSCREWS, ETC.)
214-0000-00	MISCELLANEOUS HARDWARE
220-0400-00	NUTS
251-0000-00	ALUMINUM (BULK MATERIAL: EXTRUSIONS, SHEETS, ETC.)
251-0300-00	BRASS, COPPER, BRONZE (BULK MATERIAL: SEE 258-0300-00)
251-0500-00	STEEL, TIN SOLDER, SST, ETC. (BULK MATERIAL)
251-1000-00	ALUMINUM (BULK MATERIAL: EXTRUSIONS, SHEETS, FOIL, ROD, TUBE, ETC.)
252-0000-00	VARNISH, PAINT, ETC.
252-0500-00	NON-METALLIC SHEETS (BULK: PAPER, FELT, LINOLEUM, RUBBER, FIBER -- SEE 107-)
253-0000-00	LACING CORD, TAPE, THREAD, LIGHT CONDUCTOR, ETC. (BULK)
254-0500-00	PLASTIC SHEETS & STRIPS (BAKELITE, EPOXY, FORMICA, COPPER CLAD, GLASS LAM, ETC. -- BULK)
254-0900-00 to 255-0000-00 }	PLASTIC ROD, SHEET & STRIP (PLAIN), FILM, MOLDING MATERIAL, ETC., ALL BULK
256-0000-00	CERAMIC BULK MATERIAL
257-0000-00	PRECIOUS METALS
258-0300-00	BRASS, COPPER, BRONZE (BULK MATERIAL: SEE 251-0300-00)

CATEGORY	TYPE OF PARTS
260-0000-00	SWITCHES, PURCHASED
262-0000-00	SWITCHES, WIRED
263-0000-00	SWITCHES AND ASSEMBLIES (TEK-MADE) OTHER THAN CAM OPTICAL, MBS, PANCAKE & TURRET
263-1000-00	SWITCHES AND ASSEMBLIES (TEK-MADE) CAM
276-0000-00	FORMS (COILS, TRANSFORMERS, DELAY IN, ETC.)
276-0500-00	CORES (COILS, TRANSFORMERS, FERRITE, ETC.)
281-0000-00	CAPACITORS (VARIABLE)
281-0500-00	CAPACITORS (FIXED CERAMIC)
283-0000-00	CAPACITORS (FIXED CERAMIC DISC TYPE)
283-0500-00	CAPACITORS (FIXED MICA)
285-0000-00	CAPACITORS (FIXED GLASS & PORCELAIN)
285-0500-00	CAPACITORS (FIXED PAPER & PLASTIC: INCLUDED TUBULAR TEK-MADE)
290-0000-00	CAPACITORS (FIXED ELECTROLYTIC)
291-0000-00	CAPACITORS (FIXED PLASTIC, TEK-MADE IN OVAL CAN)
291-0200-00	CAPACITOR WINDINGS (TEK-MADE)
295-0000-00	CAPACITORS (MATCHED, SELECTED, SETS, ETC.)
301-0000-00	RESISTORS (FIXED COMP - 0.5W, 5%)
302-0000-00	RESISTORS (FIXED COMP - 0.5W, 10%)
303-0000-00	RESISTORS (FIXED COMP - 1.0W, 5%)
304-0000-00	RESISTORS (FIXED COMP - 1.0W, 10%)
305-0000-00	RESISTORS (FIXED COMP - 2.0W, 5%)
306-0000-00	RESISTORS (FIXED COMP - 2.0W, 10%)
307-0000-00	RESISTORS (FIXED SPECIALS)
307-1000-00	RESISTORS (ATTENUATOR STRIPS)
308-0000-00	RESISTORS (FIXED WIREWOUND)
309-0000-00	RESISTORS (FIXED CARBON FILM - 0.5W)
310-0000-00	RESISTORS (FIXED CARBON FILM - 1.0W)
310-0500-00	RESISTORS (FIXED CARBON FILM - ABOVE 1.0W)
311-0000-00	RESISTORS (VARIABLE)
312-0000-00	RESISTORS (VARIABLE - SELECTED FROM 311- RES)
312-0100-00	RESISTORS - KNOB, MATCHED
312-0500-00	RESISTORS (FIXED - MATCHES, SELECTED, SETS, ETC. AT TEK)
314-0000-00	RESISTORS (FIXED HIGH VOLTAGE - SEE 307-)
315-0000-00	RESISTORS (FIXED COMP - 0.25W, 5%)
316-0000-00	RESISTORS (FIXED COMP - 0.25W, 10%)
317-0000-00	RESISTORS (FIXED COMP - 0.125W, 5%)
318-0000-00	RESISTORS (FIXED CARBON FILM - 0.125W, 1%)
319-0000-00	RESISTORS (FIXED CARBON FILM - 0.25W, BELOW 5%)
321-0000-00	RESISTORS (FIXED METAL FILM - 0.125W, 1% OR LESS, STANDARD RES. VALUES)
321-0600-00	RESISTORS (FIXED METAL FILM - 0.125W, 1% OR LESS, SPECIAL VALUES)
321-1000-00	RESISTORS (FIXED METAL FILM - 0.125W, 1% OR LESS, STANDARD RES. VALUES)
322-0000-00	RESISTORS (FIXED METAL FILM - 0.25W, 1% OR LESS, STANDARD RES. VALUES)

TEK PART NUMBER SYSTEM (CONT)

NUMERICAL

0

THIS IS NOT THE INDEX TO THIS CATALOG, BUT TO THE TEK PN SYSTEM IN GENERAL

CATEGORY	TYPE OF PARTS
322-0600-00	RESISTORS (FIXED METAL FILM - 0.25W, 1% OR LESS, SPECIAL VALUES)
322-1000-00	RESISTORS (FIXED METAL FILM - 0.25W, 1% OR LESS, STANDARD RES. VALUES)
323-0000-00	RESISTORS (FIXED METAL FILM - 0.5W, 1% OR LESS, STANDARD RES. VALUES)
323-0600-00	RESISTORS (FIXED METAL FILM - 0.5W, 1% OR LESS, SPECIAL VALUES)
323-1000-00	RESISTORS (FIXED METAL FILM - 0.5W, 1% OR LESS, STANDARD RES. VALUES)
324-0000-00	RESISTORS (FIXED METAL FILM - 1.0W, 1% OR LESS, STANDARD RES. VALUES)
324-0600-00	RESISTORS (FIXED METAL FILM - 1.0W, 1% OR LESS, SPECIAL VALUES)
324-1000-00	RESISTORS (FIXED METAL FILM - 1.0W, 1% OR LESS, STANDARD RES. VALUES)
325-0000-00	RESISTORS (FIXED METAL FILM - MISC. NOT FITTING IN 321- THRU 324- CATEGORIES)
331-0000-00	DIALS, GRATICULES, SCALES, WINDOW, MAST (GRAT) ETC.
333-0000-00	PANELS (ETCHED & ANODIZED - FRONT, REAR, ETC.)
334-0000-00	IDENTIFICATION ITEMS (PLATES, LABELS, ETC.)
337-0000-00	SHIELDS (ELECTRICAL & MECHANICAL - SEE ALSO 200-)
341-0000-00	VALVE & BLADDER (CANCELLED - USE 214-)
342-0000-00	INSULATORS
343-0000-00	CLAMPS & RETAINERS
344-0000-00	CLIPS, TIE STRIP, TIE PLATE, ETC.
346-000-000	STRAPS
348-0000-00	CUSHION, FOOT, GROMMET, GASKET, RESIL MOUNT, FLIP-STAND, ETC.
351-0000-00	GUIDES & SLIDES (INCLUDING CHASSIS TRACK TYPE)
352-0000-00	HOLDERS
354-0000-00	RING (INCLUDING RING, KNOB SKIRT & RING, TRIM)
355-0000-00	STUDS
355-0500-00	STEMS
358-0000-00	BUSHINGS
361-0000-00	SPACERS & SHIMS
366-0000-00 and } 366-1000-00 }	KNOBS, PUSHBUTTONS AND KNOB SHELLS
366-0500-00	KNOB-DIAL ASSEMBLY (ASSEMBLY OF 331- & 366-)
367-0000-00	HANDLES, GRIPS, PIVOT ARMS, ETC.
369-0000-00	IMPELLERS
376-0000-00	COUPLINGS
377-0000-00	INSERT (KNOB, SCREW THREAD, ETC.)
378-0000-00	FILTERS (AIR)
378-0500-00	FILTERS (LIGHT & CRT MESH & REFLECTOR LIGHT)
378-0750-00	SCREENS, GRILLES & BAFFLES (AIR)
380-0000-00	HOUSINGS
381-0000-00	BAR (COMPONENT - USE 251- & 258 - NOT BULK)
384-0000-00	EXTENSION SHAFTS
384-0500-00	SHAFTS & RODS (NOT EXTENSION OR SPACING)

CATEGORY	TYPE OF PARTS
385-0000-00	RODS (SPACING: THREADED ENDS)
386-0000-00 to } 387-0000-00 }	SUBPANELS, REAR PANELS, PLATES, SUPPORTS, STIFFENERS, LIGHT CONDUCTORS (NOT BULK), ETC.
388-0000-00	NOT ASSIGNED
388-0500-00	CIRCUIT BOARDS & CARDS (UNWIRED)
390-0000-00	CABINET PARTS (BOTTOM, TOP, SIDE, WRAPAROUND, ETC.)
391-0000-00	BLOCK
392-0000-00	BOARD & TERMINAL BOARD
401-0000-00	ROTATING DEVICES (WHEELS, CASTERS, BEARINGS, CAMS, PULLEYS, HUBS, ETC.)
405-0000-00	RACKS
406-0000-00 to } 407-0000-00 }	BRACKETS
426-0000-00	FRAMES, FRAME SECTIONS & FRAME PANELS
432-0000-00	BASES
436-0000-00	STORAGE ITEMS (DRAWER, TRAY, SHELF, ETC.)
437-0000-00	CABINETS & CABINET SUBASSEMBLIES
439-0000-00	CRT MATERIALS
440-0000-00	CRT ASSEMBLIES
441-0000-00	CHASSIS
602-0000-00	KITS, FINAL
604-0000-00	KITS, TUBE
606-0000-00	KITS, TEST
608-0000-00	KITS, SHIPPING
610-0000-00	KITS, MISCELLANEOUS CHASSIS
614-0000-00	KITS, SUBPANEL
615-0000-00	KITS, VERTICAL AMPLIFIER
616-0000-00	KITS, MISCELLANEOUS AMPLIFIER CHASSIS
619-0000-00	KITS, SWEEP, DELAY SWEEP
620-0000-00	KITS, LOW VOLTAGE POWER
621-0000-00	KITS, HIGH VOLTAGE POWER
624-0000-00	KITS, F & I
626-0000-00	KITS, CRT SHIELD
627-0000-00	KITS, MISCELLANEOUS SHIELD
630-0000-00	KITS, FRAME PLATE
631-0000-00	KITS, MISCELLANEOUS PLATES
634-0000-00	KITS, PLUG-IN HOUSING
635-0000-00	KITS, FAN MOTOR
636-0000-00	KITS, DELAY LINE
637-0000-00	KITS, RECTIFIER BRACKET
640-0000-00	KITS, MOUNTING BRACKET
643-0000-00	KITS, POWER PLUG & SOCKETS
644-0000-00	KITS, COMBINATION ASSEMBLIES
650-0000-00	KITS, MISCELLANEOUS
655-0000-00	KITS, MODULAR
660-0000-00	KITS, MISCELLANEOUS SIGNAL & TRIGGER
670-0000-00	CIRCUIT BOARD (WIRED 388-)
672-0000-00	CIRCUIT BOARD (2 OR MORE 670-)
673-0000-00	CIRCUIT BOARD SUBASSEMBLIES
675-0000-00	CIRCUIT BOARD KITS
678-0000-00	CIRCUIT BOARD SUBASSEMBLIES
700-0000-00	CIRCUIT BOARD ASSEMBLIES

PARTS AND PRODUCTS STATUS CODES

The following definitions apply to the status and source codes presently being input into the Data Base:

CR	Current Production	TC	Tequipment Current Production
EN	Engineering	IN	International
PP	Pre-Production	DS	Digital Systems
CS	Customer Service	SC	Sony/Tek Current Production
NP	Non-Production	OT	Obsolescent
DL	Deleted	MP	Modified Part
OB	Obsolete	LR	Last Supply Current
CM	Custom Mod	LS	Last Supply Customer Service
VN	Vendor		

Current Production (CR):

1. A finished product, which has "turned regular" and is currently being produced in Beaverton.
2. A component currently being purchased or produced in Beaverton for use on a current production finished product.

Engineering (EN):

An item used exclusively by Engineering which is not being used on a finished product. The item may be picked up for use in future product.

Pre-Production (PP):

1. A finished product prior to "turn regular".
2. A component used on an instrument not yet in current production, or a component going into a current product via an IRS (mod).

Customer Service (CS):

A replacement item, not used in a current production instrument, supported by Customer Service and either stocked in Customer Service, built or supplied for them on demand.

Non-Production (NP):

An item which is no longer produced or purchased and which has a replacement.

Deleted (DL):

An item that is no longer produced or purchased and which has no replacement.

Obsolete (OB):

1. A component which has matured through the Long Term Product Support Program. The usage has been out of production for 12 years (sometimes less, if accelerated). The item may continue to be supported through Obsolete Parts Notice 126.
2. An instrument which is no longer produced and which has completed the instrument phase-out program.

Custom Mod (CM):

1. An instrument modified to meet customer specifications.
2. A component used exclusively in a custom modified instrument.

Vendor (VN):

A Tek-made or purchased item which requires a vendor operation somewhere in the processing sequence.

Tequipment (TC):

An item purchased or produced by Tequipment for use exclusively in Tequipment production.

International (IN):

An item purchased or produced by Guernsey or Heerenveen for use exclusively in their production.

Digital Systems (DS):

An item purchased or produced and used exclusively by Digital Systems.

Sony/Tek (SC):

An item purchased or produced by Sony/Tek for use exclusively in Sony/Tek production.

Obsolescent (OT):

An instrument no longer produced which is in the process of going through the Corporate Instrument Phase-Out Program. Upon completion of the program, (when the Bill of Materials has been purged), the status will change to OB. This is an interim status used to identify the backlog of products being cleaned up on the new Phase-Out Program. It will not be needed once the backlog has been completed.

Modified Part (MP):

Number picked up for MODS.

Last Supply Current (LR):

No more parts will be purchased after these are gone.

Last Supply Customer (LS):

No more parts will be purchased after these are gone.

NOTES

0

HAND TOOLS

TABLE OF CONTENTS

	PAGE (S)
1/4 INCH SQUARE DRIVE SOCKETS AND ATTACHMENTS	
RATCHET	0-14
SOCKET (STANDARD DEPTH)	0-14
SOCKET (DEEP RECESS)	0-14
EXTENSION	0-14
HEX DRIVER	0-15
NUT DRIVER	0-16
PLIERS (CUTTING)	0-17 & 0-18
APPLICATION NOTE	0-18
PLIERS (MISCELLANEOUS)	0-19 & 0-20
IC INSERTION/EXTRACTION PLIERS	0-20
SCREW DRIVER	
FLAT BLADE	0-21
PHILLIPS	0-21
POZIDRIV	0-21
HOLDING	0-21
SCREW DRIVER (MAGNETIC)	0-22
DRIVER-BIT	
PHILLIPS	0-22
POZIDRIV	0-22
TORX	0-22
SLOTTED	0-22
HEX	0-22
APPLICATION NOTE (DRIVER-BIT)	0-23
APPLICATION NOTE (SOLDERING IRON TIP)	0-24
SOLDERING IRON TIP	
FOR WELLER STATION	0-25
FOR IRONS UP TO 30 WATTS	0-26
DESOLDERING IRON TIP	0-26
FOR IRONS UP TO 35 WATTS	0-27
FOR ANTEX IRON	0-27
FOR 25 THRU 60 WATTS	0-28
TWEEZERS	0-29
WRENCH	0-30
L-WRENCH	0-31
INDEX	0-32 & 0-33

THIS SECTION INCLUDES MOST OF THOSE HAND TOOLS AND RELATED ITEMS THAT ARE NORMALLY USED IN ASSEMBLY. THOSE THAT ARE NOT INCLUDED ARE SPECIALTY ITEMS OR ARE MORE THAN ADEQUATELY DESCRIBED IN THE SUPPLIES CATALOG. THE INTENTION OF THIS SECTION IS TO SUPPLEMENT THE TOOL DESCRIPTION SO THERE WILL BE NO CONFUSION AS TO THE ACTUAL CONFIGURATION OF THESE ITEMS. IF YOU HAVE TOOL PROBLEMS OR SPECIAL NEEDS, CALL FRANK JAVORSKY AT EXTENSION 2509-B.

NOTE: TEKTRONIX HAS MANY TOOL SUPPLIERS, SOME OF WHICH MAY CHANGE. THEREFORE, THE CONFIGURATION SHOWN MAY OCCASIONALLY VARY SLIGHTLY FROM THE CONFIGURATION SHOWN.

1/4 INCH SQUARE DRIVE SOCKETS AND ATTACHMENTS

RATCHET



5.250 INCHES LONG	PART NUMBER	CC
	003-0270-00	L+

SOCKET (STANDARD DEPTH)



OVERALL LENGTH: .875 INCHES

OPENING SIZE	TYPE	PART NUMBER	CC
3/16 (.187)	6 Point	003-0271-00	J
1/4 (.250)	6 Point	003-0272-00	J
5/16 (.312)	12 Lobe	003-0273-00	J
11/32 (.344)	6 Point	003-0274-00	J-
3/8 (.375)	6 Point	003-0275-00	J
7/16 (.438)	6 Point	003-0478-00	J
1/2 (.500)	12 Lobe	003-0479-00	J
9/16 (.562)	12 Lobe	003-0480-00	J+

SOCKET (DEEP RECESS)

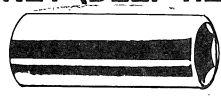

OVERALL LENGTH: 2.000 INCHES

OPENING SIZE	TYPE	PART NUMBER	CC
5/16 (.312)	6 Point	003-0481-00	K-
3/8 (.375)	6 Point	003-0482-00	K-
7/16 (.438)	6 Point	003-0483-00	K-
1/2 (.500)	6 Point	003-0484-00	J+

EXTENSION



OVERALL LENGTH	TYPE	PART NUMBER	CC
3.500 Inches Long	1/4 Inch Drive	003-0276-00	J
6.000 Inches Long	1/4 Inch Drive	003-0277-00	K

COST CODE (CC COLUMN)

CODE	A	B	C	D	E	F	G	H	I	J	K	L	M	N	O
≈ VALUE with +	.75¢	2¢	3.75¢	6¢	10¢	18¢	35¢	60¢	\$1	\$2	\$3.75	\$6	\$10	\$18	\$35+
≈ VALUE no suffix	.5¢	1.5¢	3¢	5¢	8¢	15¢	25¢	50¢	75¢	\$1.50	\$3	\$5	\$8	\$15	\$25
≈ VALUE with -	.2¢	1.25¢	2.5¢	4.25¢	7¢	13¢	22¢	40¢	65¢	\$1.25	\$2.50	\$4.25	\$7	\$13	\$22

NOTE: Costs may vary from order to order due to order quantities, vendor, etc.

HEX DRIVER



HEX SETS	PART NUMBER	CC
CONTAINS ONE EACH .050, 1/16, 5/64, 3/32, 1/8, 5/32	003-0202-00	K
CONTAINS ONE EACH 3/32, 1/8, 5/32, 3/16, 7/32	003-0203-00	K-

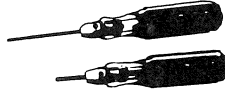

HEX SIZE (INCHES)	PART NUMBER	CC	REPLACEMENT BLADE	CC
.050	003-0088-00	K	003-0112-00	G
1/16 (.062)	003-0089-00	K	003-0113-00	G+
5/64 (.078)	003-0090-00	K	003-0114-00	G
3/32 (.093)	003-0091-00	K	003-0115-00	G
1/8 (.125)	003-0092-00	K		
(.035)	003-0093-00	K	003-0103-00	G

COST CODE (CC COLUMN)

CODE	≈ VALUE with -	≈ VALUE no suffix	≈ VALUE with +
A	.2¢	.5¢	.75¢
B	1.25¢	1.5¢	2¢
C	2.5¢	3¢	3.75¢
D	4.25¢	5¢	6¢
E	7¢	8¢	10¢
F	13¢	15¢	18¢
G	22¢	25¢	35¢
H	40¢	50¢	60¢
I	65¢	75¢	\$1
J	\$1.25	\$1.50	\$2
K	\$2.50	\$3	\$3.75
L	\$4.25	\$5	\$6
M	\$7	\$8	\$10
N	\$13	\$15	\$18
O	\$22	\$25	\$35+

NOTE: Costs may vary from order to order due to order quantities, vendor, etc.

NUT DRIVER

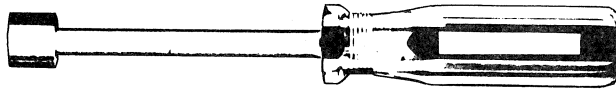

STANDARD

SOCKET SIZE	TYPE OF SHAFT	COLOR CODE	OVERALL LENGTH (INCHES)	PART NUMBER	CC
5/32 (.156)	Solid		6.000	003-0122-00	J
3/16 (.188)	Hollow	Black	9.000	003-0123-00	J+
1/4 (.250)	Hollow	Red	9.000	003-0124-00	J+
5/16 (.312)	Hollow	Yellow	9.000	003-0125-00	J+
3/8 (.375)	Hollow	Blue	9.000	003-0126-00	J+
1/4 (.250)	Solid	Red	3.250	003-0127-00	J+
3/8 (.375)	Solid	Blue	3.250	003-0129-00	J+
3/16 (.188)	Solid	Black	6.000	003-0130-00	J
7/32 (.219)	Solid		6.000	003-0131-00	J
1/4 (.250)	Solid	Red	6.000	003-0132-00	J
9/32 (.281)	Solid		6.000	003-0133-00	J
5/16 (.312)	Solid	Yellow	6.000	003-0134-00	J
11/32 (.344)	Solid	Green	6.000	003-0135-00	J
3/8 (.375)	Solid	Blue	6.000	003-0136-00	J
7/16 (.438)	Solid	Brown	7.000	003-0137-00	J+
1/2 (.500)	Hollow	Red	7.000	003-0138-00	J+
9/16 (.562)	Hollow		7.000	003-0139-00	J+
9/64 (.141)	Solid		7.000	003-0410-00	J+
5/32 (.156)	Solid		7.625	003-0411-00	J+
3/16 (.188)	Solid	Black	8.000	003-0412-00	J
7/64 (.109)	Solid		6.750	003-0446-00	J
11/32 (.344)	Solid	Green	9.000	003-0458-00	J+
1/4 (.250)	Solid	Red	9.000	003-0512-00	J+
3/32 (.094)	Solid		3.500	003-0717-00	J+

METRIC

SOCKET SIZE (mm)	TYPE OF SHAFT	OVERALL LENGTH (INCHES)	PART NUMBER	CC
4.000	Solid	6.000	003-0973-00	J
4.500	Solid	6.000	003-0974-00	J
5.000	Solid	6.000	003-0975-00	J
6.000	Solid	6.000	003-0976-00	J
7.000	Solid	6.000	003-0977-00	J
8.000	Solid	6.000	003-0978-00	J

COST CODE

(CC COLUMN)



CODE	≈ VALUE with -	≈ VALUE no suffix	≈ VALUE with +
A	.2¢	.5¢	.75¢
B	1.25¢	1.5¢	2¢
C	2.5¢	3¢	3.75¢
D	4.25¢	5¢	6¢
E	7¢	8¢	10¢
F	13¢	15¢	18¢
G	22¢	25¢	35¢
H	40¢	50¢	60¢
I	65¢	75¢	\$1
J	\$1.25	\$1.50	\$2
K	\$2.50	\$3	\$3.75
L	\$4.25	\$5	\$6
M	\$7	\$8	\$10
N	\$13	\$15	\$18
O	\$22	\$25	\$35+

NOTE: Costs may vary from order to order due to order quantities, vendor, etc.

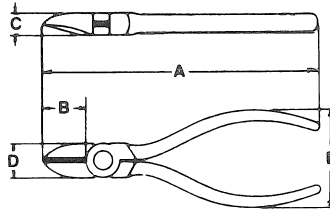
PLIERS CUTTING

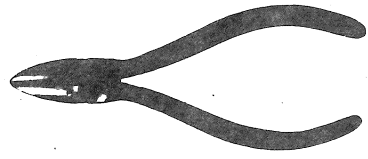

0

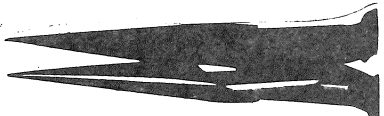
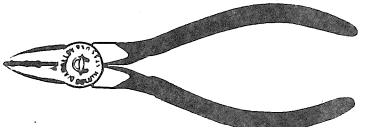
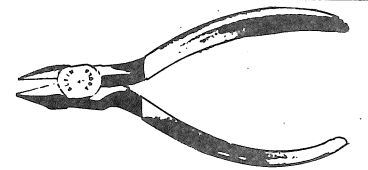
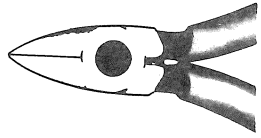
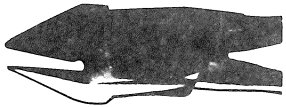
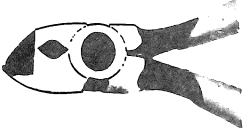
D I M E N S I O N S					DESCRIPTION	PART NUMBER	CC	
A	B	C	D	E				
5.062	.750	.375	.625	1.875	Narrow Nose Flush Cut Diagonal	003-0147-00	L	
8.000	.781	.500	1.187	1.875	Heavy Duty Diagonal Cutting Pliers	003-0148-00	L	
7.125	.812	.500	1.250	1.875	Flush Ground (not for cutting steel). They are primarily for cutting aluminum or plastic parts.	003-0150-00	L+	
5.500	.718	.296	.437	.078	Long Chain Nose - With Side Cutter	003-0151-00	L+	
5.062	.750	.375	.625	1.875	Wire Stripping Plier (for stripping 18, 20 and 22 gauge wires)	003-0156-00	M	
5.000	.625	.562	.375		Narrow Pointed Nose Specifically designed for tip cutting.	003-0159-00	M-	
4.250	.437	.250	.437	1.875	Thin Diagonal Cutter For reaching into confined spaces.	003-0168-00	L	
	.375	.359	.218		Slim Line Diagonal	003-0655-00	L	
4.187	.375	.250	.437	2.062	Angled Flush Cutter To be used on soft wire only.	003-0711-00	M	

PLIERS (CONT) CUTTING

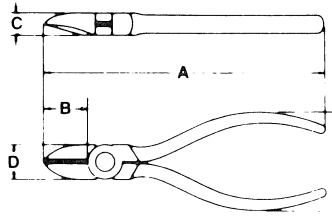

DIMENSIONS					DESCRIPTION	PART NUMBER	CC	Image
A	B	C	D	E				
					15° Flush Cutter/Safety Clip Five inches overall length	003-0746-00	K	
4.250	.437	.250	.437	1.875	Wire Holding Diagonal Pliers Wire holding clip prevents cutoff wire from flying out.	003-0846-00	M+	
					Lead Came Cutter Flush ground adjustable stop for close cutting. Overall Length: 7.000 in. Jaw Length: .687 in.	003-0848-00	M	

APPLICATION NOTE

All manufacturers of cutting pliers offer a choice of cutting edges. They are standard, semi-flush and full flush. The full flush edge will cut closer than semi-flush or standard, but will have much shorter life. Generally speaking, the best cutting edge to use is semi-flush, because it gives a close enough cut for most assembly work, yet has good life.

See below for further description of cutting edges:



<p>Standard Cutting For cutting hard wire.</p>	
<p>Semi-Flush Cutting For close cutting of medium wire.</p>	
<p>Full-Flush Cutting For close, flat cutting of soft wire only.</p>	

PLIERS (CONT)

MISCELLANEOUS

KEY TO PLIER DIMENSIONS

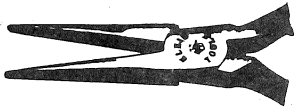
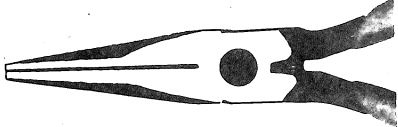
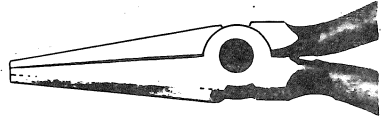
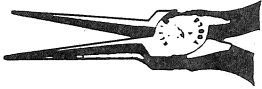
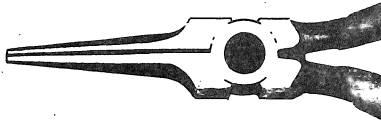
- | | |
|---------------------------|---|
| A. Overall Length | E. Handle Width |
| B. Jaw Length | F. Jaw Thickness at Tips |
| C. Jaw Thickness at Joint | G. Jaw Width at Tips |
| D. Jaw Width at Joint | H. Special Jaw Lengths or
Cutter Lengths |

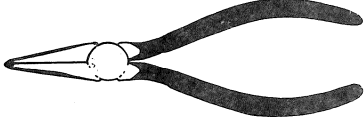
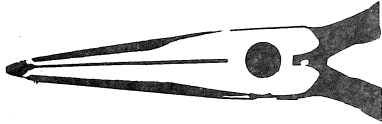
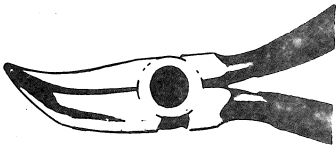
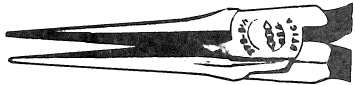
DIMENSIONS							DESCRIPTION	PART NUMBER	CC	ILLUSTRATIONS
A	B	C	D	E	F	G				
5.593	1.750	.312	.531				Concave Outside Jaws	003-0145-00	L+	
6.000	1.687	.281	.500	1.875	.078	.046	Long Nose - Scored Jaws	003-0146-00	L+	
4.000	.687	.250	.437	1.875	.093	.156	Duck Bill - Smooth Jaws	003-0152-00	K+	
6.625	1.937	.375	.687				Tapered Long Nose	003-0153-00	L	
5.500	1.750	.250	.500	2.062	.093	.062	Needle Nose - Smooth Jaws	003-0154-00	L+	
6.625	1.937	.375	.687				Long Nose	003-0155-00	L	
6.625	.250	.375	.687	2.062			Long Nose Special cutting one-quarter inch cutter on end of nose	003-0157-00	M-	
5.000	1.625	.250	.500	2.062	.250	.031	Long Nose - End Cutter	003-0166-00	M+	
4.500	.750	.250	.437	1.875	.078	.046	Curved Long Nose - Smooth Jaws Nose Bent	003-0490-00	L-	
5.500	1.750	.250	.500				Needle Nose	003-0601-00	L	

PLIERS (CONT)

MISCELLANEOUS

KEY TO PLIER DIMENSIONS

- | | |
|---------------------------|---|
| A. Overall Length | E. Handle Width |
| B. Jaw Length | F. Jaw Thickness at Tips |
| C. Jaw Thickness at Joint | G. Jaw Width at Tips |
| D. Jaw Width at Joint | H. Special Jaw Lengths or
Cutter Lengths |

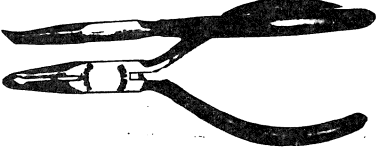
DIMENSIONS							DESCRIPTION	PART NUMBER	CC	ILLUSTRATIONS
A	B	C	D	E	F	G				
6.000	2.296	.296	.500				Long Nose - Serrated Jaws	003-0784-00	L+	
4.750	1.000	.250	.437				Semi-Flush Cutting Good for dips and other integrated circuit packages	003-1018-00	N-	

IC INSERTION/EXTRACTION PLIERS

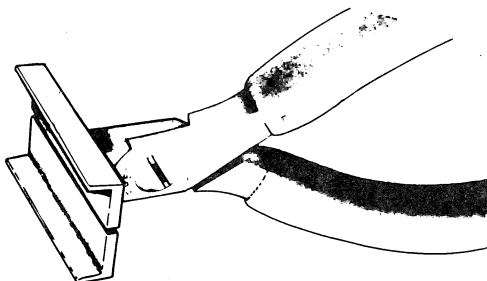

USAGE	PART NUMBER	CC
For 18 and 22 Pin Dip	003-0878-00	0+
For 24 and 28 Pin Dip	003-0879-00	0+
For 40 Pin Dip	003-0880-00	0+

COST CODE (CC COLUMN)

CODE	A	B	C	D	E	F	G	H	I	J	K	L	M	N	O
≈ VALUE with +	.75¢	2¢	3.75¢	6¢	10¢	18¢	35¢	60¢	\$1	\$2	\$3.75	\$6	\$10	\$18	\$35+
≈ VALUE no suffix	.5¢	1.5¢	3¢	5¢	8¢	15¢	25¢	50¢	75¢	\$1.50	\$3	\$5	\$8	\$15	\$25
≈ VALUE with -	.2¢	1.25¢	2.5¢	4.25¢	7¢	13¢	22¢	40¢	65¢	\$1.25	\$2.50	\$4.25	\$7	\$13	\$22

NOTE: Costs may vary from order to order due to order quantities, vendor, etc.

SCREW DRIVER

FLAT BLADE



FOR SCREW SIZE	APPROXIMATE OVERALL LENGTH (IN)	OTHER	PART NUMBER	CC
#8, 10 1/16 Bit Width	10-1/8 (10.125)		003-0169-00	J+
#1, 2	3-3/16 (3.187)	Jewelers	003-0179-00	I+
#4, 6	3.000	Offset	003-0181-00	J+
#6	5-1/4 (5.250)	Pocket Clip	003-0192-00	I+
	7-5/8 (7.625)		003-0199-00	J-
#4	5-1/2 (5.500)	5/32 Dia Shank	003-0511-00	I
#4	5-1/2 (5.500)	5/32 Dia Shank	003-0513-00	I+
#8, 10	7-7/8 (7.875)		003-0515-00	J+
#4, 6	13-5/8 (13.625)		003-0516-00	J+
#2, 4	4-1/2 (4.500)		003-0517-00	I
#8, 10	13-7/8 (13.875)		003-0518-00	J+
PHILLIPS				
#1	2-15/16 (2.937)		003-0170-00	J+
#1	3.000		003-0341-00	J+
#1, 2		Offset	003-0420-00	J-
#2	11-5/8 (11.625)		003-0422-00	J+
#2	3-5/8 (3.625)		003-0423-00	J-
#1	13-5/8 (13.625)		003-0472-00	J+
#0	5-3/4 (5.750)		003-0640-00	K-
#1	7-7/8 (7.875)		003-0684-00	J+
POZIDRIV				
#1	6-3/4 (6.750)		003-0616-00	J+
#2	8-1/2 (8.500)		003-0967-00	K-
HOLDING				
#6, 8	6-5/8 (6.625)		003-0197-00	J+
#0 to #4	5.000		003-0764-00	J-

COST CODE

(CC COLUMN)

CODE	A	B	C	D	E	F	G	H	I	J	K	L	M	N	O
≈ VALUE with +	.75¢	2¢	3.75¢	6¢	10¢	18¢	35¢	60¢	\$1	\$2	\$3.75	\$6	\$10	\$18	\$35+
≈ VALUE no suffix	.5¢	1.5¢	3¢	5¢	8¢	15¢	25¢	50¢	75¢	\$1.50	\$3	\$5	\$8	\$15	\$25
≈ VALUE with -	.2¢	1.25¢	2.5¢	4.25¢	7¢	13¢	22¢	40¢	65¢	\$1.25	\$2.50	\$4.25	\$7	\$13	\$22

NOTE: Costs may vary from order to order due to order quantities, vendor, etc.

SCREW DRIVER (MAGNETIC)

(FOR USE WITH 1/4 IN. HEX DRIVE BITS)



LENGTH	PART NUMBER	CC
8 1/2 (8.500)	003-0293-00	K+
3 1/2 (3.500)	003-0445-00	K+
11 5/8 (11.625)	003-0524-00	K+

DRIVER-BITS (1/4 INCH HEX DRIVE)

PHILLIPS



POINT SIZE	OVERALL LENGTH (IN.)	PART NUMBER	CC
#0	1.000	003-0368-00	H+
#0	1.937	003-0009-00	I+
#1	1.000	003-0335-00	G-
#1	1.937	003-0415-00	H-
#2	1.000	003-0336-00	G-

POZIDRIV



POINT SIZE	OVERALL LENGTH (IN.)	PART NUMBER	CC
#1	1.000	003-0443-00	G-
#1	1.937	003-0602-00	H
#2	1.000	003-0444-00	G

TORX



POINT SIZE	OVERALL LENGTH (IN.)	PART NUMBER	CC
T7	1.000	003-1293-00	J+
T8	1.000	003-0964-00	J-
T9	1.000	003-0965-00	J-
T15	1.000	003-0966-00	J-
T20	1.937	003-0866-00	J+

SLOTTED



POINT SIZE	OVERALL LENGTH (IN.)	PART NUMBER	CC
For #6 & #8 Screw	1.500	003-0447-00	G+
For #8 & #10 Screw	1.500	003-0448-00	G+

HEX



POINT SIZE	OVERALL LENGTH (IN.)	PART NUMBER	CC
3/32 (.093)	1.000	003-0970-00	I
1/8 (.125)	1.000	003-0971-00	I
3/16 (.187)	1.937	003-1254-00	I

APPLICATION NOTE

DRIVER-BIT

Tektronix used fasteners with straight, Phillips, Pozidriv, Torx and hex recesses. Trying to determine which driver-bit type to use is no problem, except for Phillips and Pozidriv. These two recesses look alike, but have one difference that makes bit selection important. The driving flutes of a Pozidriv recess are much wider than those of a Phillips; therefore, a Pozidriv bit will not engage properly into a Phillips recess. If you use a Pozidriv bit in a Phillips recess, the result will be recess burring.

You can, in an emergency, use a Phillips bit in a Pozidriv recess, but extreme care must be exercised since bit engagement will be rather loose.

If you are having a camout and/or recess burring problem, check (a) the type of fastener recess and (b) the type of bit being used. The Pozidriv recess can be identified by a small line between each driving flute (see drawing below). Then choose the proper type (Phillips, Pozidriv, etc.) and size (#0, #1, etc.) of bit. Each bit is marked by type and size, making identification easy. The fastener recess size depends on the fastener size and generally follows the chart shown below. (This chart applies only to Phillips and Pozidriv fasteners. Check fastener specifications for other types of recesses.)

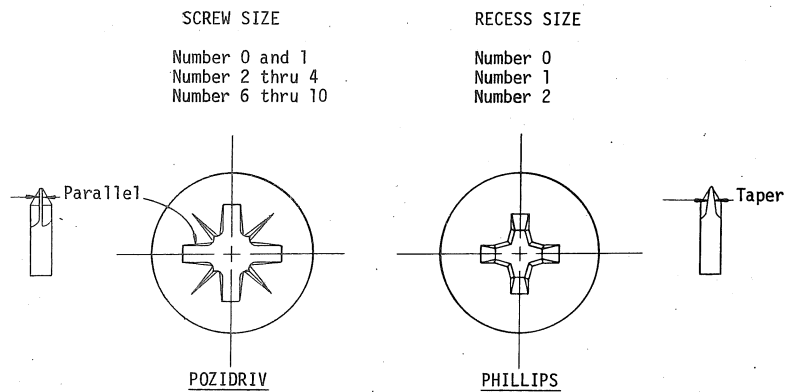

COST CODE

(CC COLUMN)

CODE	≈ VALUE with -	≈ VALUE no suffix	≈ VALUE with +
A	.2¢	.5¢	.75¢
B	1.25¢	1.5¢	2¢
C	2.5¢	3¢	3.75¢
D	4.25¢	5¢	6¢
E	7¢	8¢	10¢
F	13¢	15¢	18¢
G	22¢	25¢	35¢
H	40¢	50¢	60¢
I	65¢	75¢	\$1
J	\$1.25	\$1.50	\$2
K	\$2.50	\$3	\$3.75
L	\$4.25	\$5	\$6
M	\$7	\$8	\$10
N	\$13	\$15	\$18
O	\$22	\$25	\$35+

NOTE: Costs may vary from order to order due to order quantities, vendor, etc.

APPLICATION NOTE

SOLDERING IRON TIP

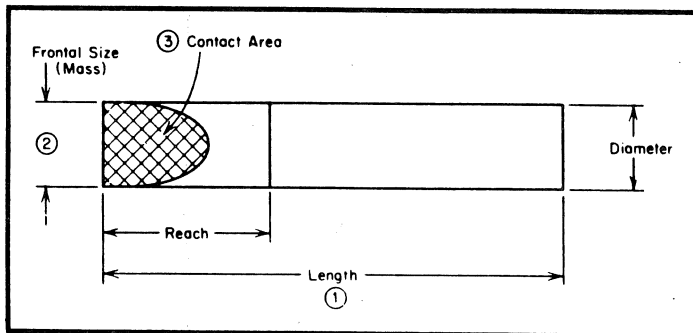

Figure 7, tip design factors that assure maximum flow of heat.

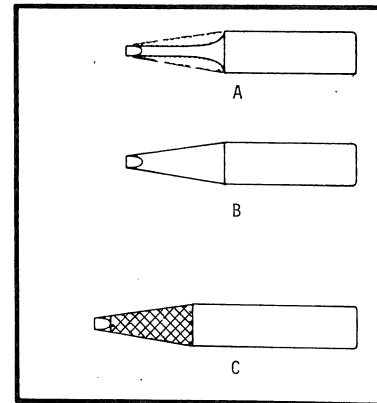

Figure 8, taper can influence heat retention and transfer properties.

Emphasis always has been placed on the selection of the soldering iron with too little attention paid to the design of the soldering iron tip. There are four tip design factors that should be considered to assure maximum flow of heat, thus permitting the greatest rate of productivity for reliable connections at minimal cost. These are (1) tip length, (2) frontal size (mass), (3) contact area, and (4) tip construction. See Figure 7.

1. **Tip Length** - In order to assure the greatest flow of heat from the element (heater) to the working face of the tip, it is recommended that the tip be as short as possible. On a standard 1/4 inch tip, a rule of thumb is that you decrease tip temperature 100°F per inch of length added to tip.
2. **Frontal Size (Mass)** - Every effort must be made to utilize the largest frontal size possible. Too many engineers, because of some tight spots, standardize on long, turned down tips (Figure 8A), losing the heat retention and transfer properties so important in maintaining constant heat output. Figure 8B shows a tip having the same point face. However since it is a conical taper, it is far more efficient.
3. **Contact Area** - All of the heat from the iron and tip must be transferred to the solder connection through the tip contact area. Therefore, the more interface between tip and solder connection, the shorter the dwell time. Of paramount importance is the fact that the tip must be readily tinnable. It must maintain a solder coat at all times since it is the solder that actually transfers the heat to the connection. The contact area should be selected and designed to suit (match) the soldering task.
4. **Tip Construction** - The tip should be copper base with electro-deposited, high grade iron on the front end (see Figure 8C). The back of the tip should be stainless steel coated. This prevents the tip from ever sticking in the iron. The point face should be tinned with tin/lead solder. The cross hatched area should be immunized with nickel/chrome to prevent solder from creeping toward the soldering iron barrel.

SOLDERING IRON TIPS

(FOR WELLER STATIONS)

NOTE: THESE ARE IRON-CLAD, LONG LIFE TIPS. UNDER NO CIRCUMSTANCES SHOULD THEY BE FILED.

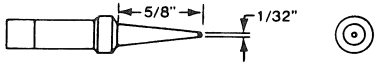
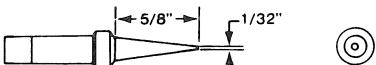
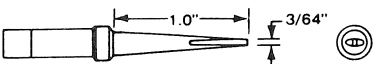
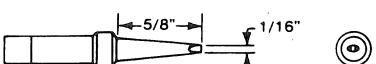
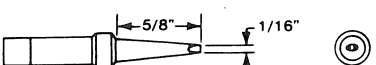
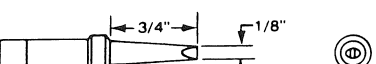
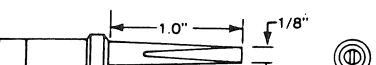
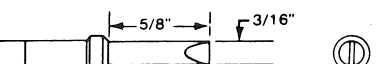
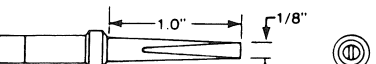
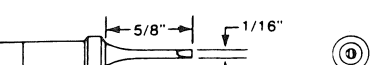
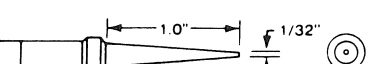
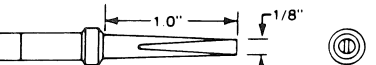
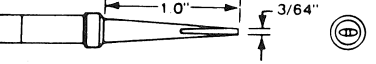
CONFIGURATION	TEMP. °F*	PART NUMBER	CC
	800	003-0913-00	J+
	800	003-0914-00	J+
	800	003-0915-00	J+
	700	003-0916-00	J+
	800	003-0917-00	J
	700	003-0918-00	J+
	800	003-0919-00	J+
	800	003-0920-00	J+
	600	003-0945-00	J+
	700	003-0946-00	J+
	900	003-1234-00	J+
	900	003-1236-00	K-
	900	003-1235-00	K-

* TEMPERATURE IS VALUE REACHED BY THE TIP WHEN IRON IS AT IDLE.

SOLDERING IRON TIPS(CONT)

(DESIGNED FOR IRONS UP TO 30 WATTS)

LENGTH 2.250 INCHES
DIAMETER .187 INCHES

	PART NUMBER	CC
	003-0898-00	J-
	003-0899-00	J
	003-0900-00	J
	003-0901-00	J+
	003-0902-00	J+
	003-0903-00	J

DESOLDERING IRON TIPS

Tips fit Weller
DS-100

DIMENSION			PART NUMBER	CC
L	D ₁	D ₂		
.500	.040	.090	003-0921-00	K+
.500	.050	.105	003-0922-00	K+
.500	.080	.125	003-0923-00	K

SOLDERING IRON TIPS (CONT)



LENGTH 2.250 INCHES (DESIGNED FOR IRONS UP TO 35 WATTS)
 DIAMETER .250 INCHES

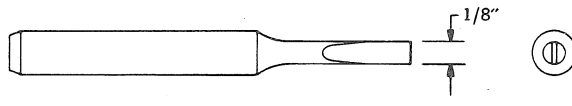
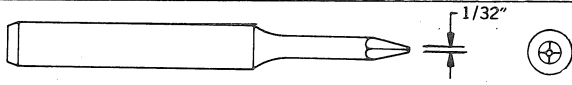
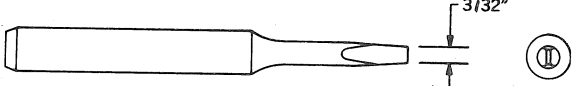
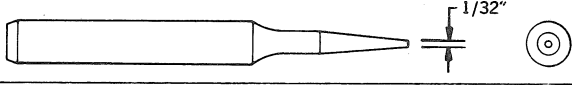
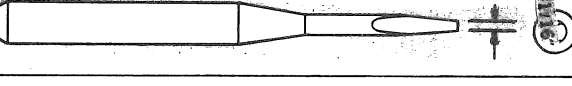
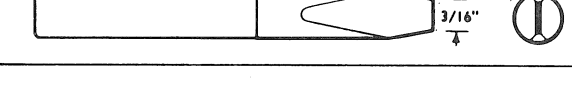
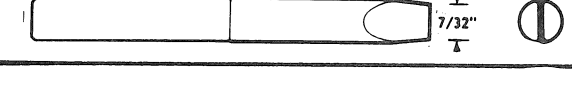

	PART NUMBER	CC
	003-0904-00	J
	003-0905-00	J+
	003-0906-00	J+
	003-0907-00	J
	003-0908-00	J+
	003-0909-00	J+
	003-0910-00	J+

SLEEVE TYPE (FOR ANTEX IRON)

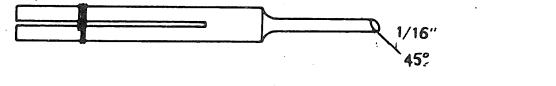
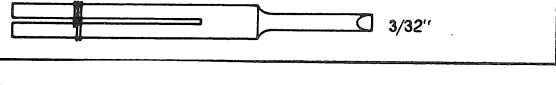
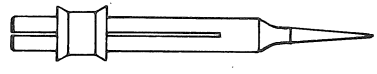
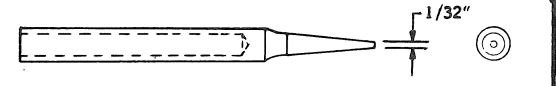
ANTEX IRON PART NUMBER CC
 15W 003-0338-01 M
 18W 003-0783-00 M+

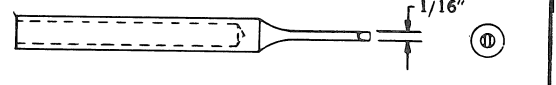
	003-0896-00	J
	003-0701-00	J-
 TYPICAL TIP DRAWING These sleeve type tips are slotted as shown and are furnished with a retainer ring.		
	003-0897-00	J+
	003-0339-00	H
	003-0523-00	I-

SOLDERING IRON TIPS (CONT)

FOR STANDARD 25 THROUGH 60 WATT IRONS. TIP INSERTED INTO IRON BARREL AND NORMALLY HELD IN PLACE BY A SETSCREW.

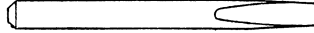

DIMENSION A	LENGTH	PART NUMBER	CC
.187	2.500	003-0225-00	I-
.250	2.625	003-0234-00	I+
.250	3.562	003-0227-00	F+

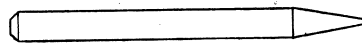

DIMENSION A	LENGTH	PART NUMBER	CC
.250	3.000	003-0235-00	
.250	4.000	003-0231-00	G+
.375	3.500	003-0232-00	J-



DIMENSIONS A B	LENGTH	PART NUMBER	CC
.250 .125	2.750	003-0656-00	I+
.250 .125	3.750	003-0233-00	I+

* NOTE: THESE ARE PLAIN COPPER TIPS. THEY HAVE VERY SHORT LIFE (1 - 2 DAYS) AND THEIR USAGE IS NOT RECOMMENDED. SIMILAR CONFIGURATIONS OF LONG LIFE DESIGN ARE AVAILABLE AND SHOULD BE USED IN PLACE OF THESE.

TWEEZERS

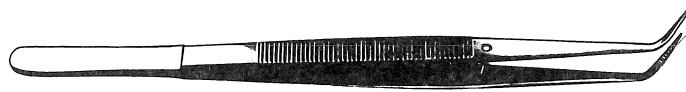

MATERIAL	LENGTH	TYPE TIP	PART NUMBER	CC
SS	5.000	Serrated	003-0236-00	K+
SS	6.500	Serrated	003-0604-00	K+



MATERIAL	LENGTH	TYPE TIP	PART NUMBER	CC
SS	4.500	Smooth	003-0464-00	K+



MATERIAL	LENGTH	TYPE TIP	PART NUMBER	CC
SS	4.500	Smooth	003-0465-00	L-



MATERIAL	LENGTH	TYPE TIP	PART NUMBER	CC
SS	4.500	Straight	003-0499-00	K



MATERIAL	LENGTH	TYPE TIP	PART NUMBER	CC
	4.500	Broad	003-0664-00	K



MATERIAL	LENGTH	TYPE TIP	PART NUMBER	CC
	4.750	Broad	003-0721-00	K+

WRENCHES



COMBINATION

OPENING	TYPE	OVERALL LENGTH	PART NUMBER	CC
9/32 x 9/32	6 Point	3.718	003-0245-00	K-
1/4 x 1/4	6 Point	3.718	003-0246-00	K-
5/16 x 5/16	6 Point	4.218	003-0247-00	K-
11/32 x 11/32	12 Lobe	4.218	003-0248-00	K
3/8 x 3/8	12 Lobe	4.687	003-0249-00	K-
7/16 x 7/16	12 Lobe	5.187	003-0250-00	K-
1/2 x 1/2	12 Lobe	5.687	003-0251-00	K
9/16 x 9/16	12 Lobe	6.218	003-0252-00	K
5/8 x 5/8	12 Lobe	6.843	003-0253-00	K
11/16 x 11/16	12 Lobe	7.468	003-0254-00	K+
3/4 x 3/4	12 Lobe	8.125	003-0255-00	K+
13/16 x 13/16	12 Lobe	9.500	003-0256-00	L+

OPEN END

OPENING	PART NUMBER	CC
3/16 x 3/16	003-0258-00	K-
1/4 x 1/4	003-0259-00	K-
5/16 x 5/16	003-0260-00	K-
11/32 x 11/32	003-0261-00	K-
3/8 x 3/8	003-0262-00	K-
7/16 x 7/16	003-0263-00	K-

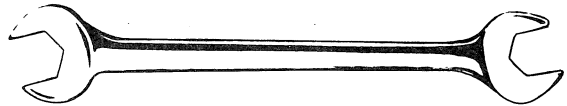

BOX END OFFSET



OPENING	TYPE	PART NUMBER	CC
5/8 x 11/16	12 Lobe	003-0243-00	L
13/16 x 7/8	12 Lobe	003-0244-00	L-
1/2 x 1/2	12 Lobe	003-0264-00	K

ADJUSTABLE



SIZE (INCHES)	CAPACITY (INCHES)	PART NUMBER	CC
4.000	1/2	003-0239-00	K+
6.000	3/4	003-0240-00	K+
8.000	15/16	003-0241-00	L-
10.000	1-1/8	003-0242-00	L

L-WRENCH



SHORT ARM

HEX SIZE (INCHES)	LENGTH (INCHES)	PART NUMBER	CC
5/32 (.156)	2.500	003-0104-00	E+
.050	1.700	003-0105-00	E-
1/16 (.062)	1.700	003-0106-00	E-
5/64 (.078)	1.900	003-0107-00	E-
3/32 (.093)	2.000	003-0108-00	E-
1/8 (.125)	2.200	003-0109-00	E
3/16 (.187)	2.700	003-0110-00	F
1/4 (.250)	3.200	003-0111-00	G

LONG ARM

5/8 (.625)	9.000	003-1110-00	L
1/2 (.500)	8.200	003-1111-00	K-
7/16 (.437)	7.500	003-1112-00	J+
3/8 (.375)	6.700	003-1113-00	I+
5/16 (.312)	6.000	003-1114-00	I-
1/4 (.250)	5.200	003-1115-00	H-
7/32 (.218)	4.900	003-1116-00	G
3/16 (.187)	4.500	003-1117-00	F+
5/32 (.156)	4.100	003-1118-00	F
3/32 (.094)	3.700	003-1120-00	F-
7/64 (.109)	3.600	003-1121-00	F-
3/32 (.094)	3.400	003-1122-00	E+
5/64 (.078)	5.700	003-1123-00	E+
9/16 (.562)	5.700	003-1125-00	J+
1/2 (.500)	5.200	003-1126-00	J
3/8 (.375)	4.200	003-1127-00	I-
5/16 (.312)	3.700	003-1128-00	H-
7/32 (.218)	3.000	003-1129-00	F+
9/64 (.140)	2.400	003-1130-00	E+
.028)	1.200	003-1131-00	F-

COST CODE

(CC COLUMN)

CODE	A	B	C	D	E	F	G	H	I	J	K	L	M	N	O
≈ VALUE with +	.75¢	2¢	3.75¢	6¢	10¢	18¢	35¢	60¢	\$1	\$2	\$3.75	\$6	\$10	\$18	\$35+
≈ VALUE no suffix	.5¢	1.5¢	3¢	5¢	8¢	15¢	25¢	50¢	75¢	\$1.50	\$3	\$5	\$8	\$15	\$25
≈ VALUE with -	.2¢	1.25¢	2.5¢	4.25¢	7¢	13¢	22¢	40¢	65¢	\$1.25	\$2.50	\$4.25	\$7	\$13	\$22

NOTE: Costs may vary from order to order due to order quantities, vendor, etc.

CROSS-REFERENCE INDEX

HAND TOOLS

PART NUMBER	DESCRIPTION	PAGE NO.	STATUS
003-0009-00	Bit	0-22	CR
003-0103-00	Hex Driver	0-15	CR
003-0104-00	Wrench	0-31	CR
003-0105-00	Wrench	0-31	CR
003-0106-00	Wrench	0-31	CR
003-0107-00	Wrench	0-31	CR
003-0108-00	Wrench	0-31	CR
003-0109-00	Wrench	0-31	CR
003-0110-00	Wrench	0-31	CR
003-0111-00	Wrench	0-31	CR
003-0112-00	Hex Driver	0-15	CR
003-0113-00	Hex Driver	0-15	CR
003-0114-00	Hex Driver	0-15	CR
003-0115-00	Hex Driver	0-15	CR
003-0122-00	Nut Driver	0-16	CR
003-0123-00	Nut Driver	0-16	CR
003-0124-00	Nut Driver	0-16	CR
003-0125-00	Nut Driver	0-16	CR
003-0126-00	Nut Driver	0-16	CR
003-0127-00	Nut Driver	0-16	CR
003-0129-00	Nut Driver	0-16	CR
003-0130-00	Nut Driver	0-16	CR
003-0131-00	Nut Driver	0-16	CR
003-0132-00	Nut Driver	0-16	CR
003-0133-00	Nut Driver	0-16	CR
003-0134-00	Nut Driver	0-16	CR
003-0135-00	Nut Driver	0-16	CR
003-0136-00	Nut Driver	0-16	CR
003-0137-00	Nut Driver	0-16	CR
003-0138-00	Nut Driver	0-16	CR
003-0139-00	Nut Driver	0-16	CR
003-0145-00	Pliers	0-19	CR
003-0146-00	Pliers	0-19	CR
003-0147-00	Pliers	0-17	CR
003-0148-00	Pliers	0-17	CR
003-0150-00	Pliers	0-17	CR
003-0151-00	Pliers	0-17	CR
003-0152-00	Pliers	0-19	CR
003-0153-00	Pliers	0-19	CR
003-0154-00	Pliers	0-19	CR
003-0155-00	Pliers	0-19	CR
003-0156-00	Pliers	0-17	CR
003-0157-00	Pliers	0-19	CR
003-0159-00	Pliers	0-17	CR
003-0166-00	Pliers	0-19	CR
003-0168-00	Pliers	0-17	CR
003-0169-00	Screw Driver	0-21	CR
003-0170-00	Screw Driver	0-21	CR
003-0179-00	Screw Driver	0-21	CS
003-0181-00	Screw Driver	0-21	CR
003-0192-00	Screw Driver	0-21	CR
003-0197-00	Screw Driver	0-21	CR
003-0199-00	Screw Driver	0-21	CR
003-0202-00	Hex Driver	0-15	CR
003-0203-00	Hex Driver	0-15	CR
003-0225-00	Solder Tip	0-28	CR
003-0227-00	Solder Tip	0-28	CR
003-0231-00	Solder Tip	0-28	CR
003-0232-00	Solder Tip	0-28	CR
003-0233-00	Solder Tip	0-28	CR
003-0234-00	Solder Tip	0-28	CR
003-0235-00	Solder Tip	0-28	CR
003-0236-00	Tweezer	0-29	CR
003-0239-00	Wrench	0-30	CR
003-0240-00	Wrench	0-30	CR
003-0241-00	Wrench	0-30	CR
003-0242-00	Wrench	0-30	CR
003-0243-00	Wrench	0-30	CR
003-0244-00	Wrench	0-30	CR
003-0245-00	Wrench	0-30	CR
003-0246-00	Wrench	0-30	CR
003-0247-00	Wrench	0-30	CR
003-0248-00	Wrench	0-30	CR
003-0249-00	Wrench	0-30	CR
003-0250-00	Wrench	0-30	CR

PART NUMBER	DESCRIPTION	PAGE NO.	STATUS
003-0251-00	Wrench	0-30	CR
003-0252-00	Wrench	0-30	CR
003-0253-00	Wrench	0-30	CR
003-0254-00	Wrench	0-30	CR
003-0255-00	Wrench	0-30	CR
003-0256-00	Wrench	0-30	CR
003-0258-00	Wrench	0-30	CR
003-0259-00	Wrench	0-30	CR
003-0260-00	Wrench	0-30	CR
003-0261-00	Wrench	0-30	CR
003-0262-00	Wrench	0-30	CR
003-0263-00	Wrench	0-30	CR
003-0264-00	Wrench	0-30	CR
003-0270-00	Ratchet	0-14	CR
003-0271-00	Socket	0-14	CR
003-0272-00	Socket	0-14	CR
003-0273-00	Socket	0-14	CR
003-0274-00	Socket	0-14	CR
003-0275-00	Socket	0-14	CR
003-0276-00	Extension	0-14	CR
003-0277-00	Extension	0-14	CR
003-0293-00	Screw Driver	0-22	CR
003-0335-00	Bit	0-22	CR
003-0336-00	Bit	0-22	CR
003-0339-00	Solder Tip	0-27	CR
003-0341-00	Screw Driver	0-21	CR
003-0368-00	Bit	0-22	CR
003-0410-00	Nut Driver	0-16	CR
003-0411-00	Nut Driver	0-16	CR
003-0412-00	Nut Driver	0-16	CR
003-0415-00	Bit	0-22	CS
003-0420-00	Screw Driver	0-21	CR
003-0422-00	Screw Driver	0-21	CR
003-0423-00	Screw Driver	0-21	CR
003-0443-00	Bit	0-22	CR
003-0444-00	Bit	0-22	CR
003-0445-00	Screw Driver	0-22	CR
003-0446-00	Nut Driver	0-16	CR
003-0447-00	Bit	0-22	CR
003-0448-00	Bit	0-22	CR
003-0458-00	Nut Driver	0-16	CR
003-0464-00	Tweezer	0-29	CR
003-0465-00	Tweezer	0-29	CR
003-0472-00	Screw Driver	0-21	CR
003-0478-00	Socket	0-14	CR
003-0479-00	Socket	0-14	CR
003-0480-00	Socket	0-14	CR
003-0481-00	Socket	0-14	CR
003-0482-00	Socket	0-14	CR
003-0483-00	Socket	0-14	CR
003-0484-00	Socket	0-14	CR
003-0490-00	Pliers	0-19	CR
003-0499-00	Tweezer	0-29	CR
003-0511-00	Screw Driver	0-21	CR
003-0512-00	Nut Driver	0-16	CR
003-0513-00	Screw Driver	0-21	CR
003-0515-00	Screw Driver	0-21	CR
003-0516-00	Screw Driver	0-21	CS
003-0517-00	Screw Driver	0-21	CR
003-0518-00	Screw Driver	0-21	CR
003-0523-00	Solder Tip	0-27	CR
003-0524-00	Screw Driver	0-22	CR
003-0601-00	Pliers	0-19	CR
003-0602-00	Bit	0-22	CR
003-0604-00	Tweezer	0-29	CR
003-0616-00	Screw Driver	0-21	CR
003-0640-00	Screw Driver	0-21	CR
003-0655-00	Pliers	0-17	CR
003-0656-00	Solder Tip	0-28	CR
003-0664-00	Tweezer	0-29	CR
003-0684-00	Screw Driver	0-21	CR
003-0701-00	Solder Tip	0-27	CR
003-0711-00	Pliers	0-17	CR
003-0717-00	Nut Driver	0-16	CR
003-0721-00	Tweezer	0-29	CR

CROSS-REFERENCE INDEX (CONT)

HAND TOOLS

0

PART NUMBER	DESCRIPTION	PAGE NO.	STATUS§§
003-0746-00	Pliers	0-18	CR
003-0764-00	Screw Driver	0-21	CR
003-0784-00	Pliers	0-20	CR
003-0846-00	Pliers	0-18	CR
003-0848-00	Pliers	0-18	CR
003-0866-00	Bit	0-22	CR
003-0878-00	Pliers	0-20	CR
003-0879-00	Pliers	0-20	CR
003-0880-00	Pliers	0-20	CR
003-0896-00	Solder Tip	0-27	CR
003-0897-00	Solder Tip	0-27	CR
003-0898-00	Solder Tip	0-26	CR
003-0899-00	Solder Tip	0-26	CR
003-0900-00	Solder Tip	0-26	CR
003-0901-00	Solder Tip	0-26	CR
003-0902-00	Solder Tip	0-26	CR
003-0903-00	Solder Tip	0-26	CR
003-0904-00	Solder Tip	0-27	CR
003-0905-00	Solder Tip	0-27	CR
003-0906-00	Solder Tip	0-27	CR
003-0907-00	Solder Tip	0-27	CR
003-0908-00	Solder Tip	0-27	CR
003-0909-00	Solder Tip	0-27	CR
003-0910-00	Solder Tip	0-27	CR
003-0913-00	Solder Tip	0-25	CR
003-0914-00	Solder Tip	0-25	CR
003-0915-00	Solder Tip	0-25	CR
003-0916-00	Solder Tip	0-25	CR
003-0917-00	Solder Tip	0-25	CR
003-0918-00	Solder Tip	0-25	CR
003-0919-00	Solder Tip	0-25	CR
003-0920-00	Solder Tip	0-25	CR
003-0921-00	Solder Tip	0-26	CR
003-0922-00	Solder Tip	0-26	CR
003-0923-00	Solder Tip	0-26	CR
003-0945-00	Solder Tip	0-25	CR
003-0946-00	Solder Tip	0-25	CR
003-0964-00	Bit	0-22	CR
003-0965-00	Bit	0-22	CR
003-0966-00	Bit	0-22	CR
003-0967-00	Screw Driver	0-21	CR
003-0970-00	Bit	0-22	CS
003-0971-00	Bit	0-22	CS
003-0973-00	Nut Driver	0-16	CR
003-0974-00	Nut Driver	0-16	CR
003-0975-00	Nut Driver	0-16	CR
003-0976-00	Nut Driver	0-16	CR
003-0977-00	Nut Driver	0-16	CR
003-0978-00	Nut Driver	0-16	CR
003-1018-00	Pliers	0-20	CR
003-1110-00	L-Wrench	0-31	CR
003-1111-00	L-Wrench	0-31	CR
003-1112-00	L-Wrench	0-31	CR
003-1113-00	L-Wrench	0-31	CR
003-1114-00	L-Wrench	0-31	CR
003-1115-00	L-Wrench	0-31	CR
003-1116-00	L-Wrench	0-31	CR
003-1117-00	L-Wrench	0-31	CR
003-1118-00	L-Wrench	0-31	CR
003-1120-00	L-Wrench	0-31	CR
003-1121-00	L-Wrench	0-31	CR
003-1122-00	L-Wrench	0-31	CR
003-1123-00	L-Wrench	0-31	CR
003-1125-00	L-Wrench	0-31	CR
003-1126-00	L-Wrench	0-31	CR
003-1127-00	L-Wrench	0-31	CR
003-1128-00	L-Wrench	0-31	CR
003-1129-00	L-Wrench	0-31	CR
003-1130-00	L-Wrench	0-31	CR
003-1131-00	L-Wrench	0-31	CR
003-1234-00	Solder Tip	0-25	CR
003-1235-00	Solder Tip	0-25	CR
003-1236-00	Solder Tip	0-25	CR
003-1254-00	Bit	0-22	CR
003-1293-00	Bit	0-22	CR

§§ STATUS CODES

CR	Current Production
EN	Engineering
PP	Pre-Production
CS	Customer Service
NP	Non-Production
DL	Deleted
OB	Obsolete Instrument
CM	Custom Mod Instrument
DS	Digital Systems
OT	Obsolescent Instrument
MP	Modified Part
LR	Last Supply Current
LS	Last Supply Customer Service
VN	Vendor
TC	Tequipment Current Production
IN	International
SC	Sony/Tek Current Production

THE STATUS IN THIS CATALOG WAS CORRECT AT THE TIME IT WAS PUBLISHED, BUT IT IS SUBJECT TO CHANGE.

§ TO USE A PART WITH THIS STATUS ON A NEW INSTRUMENT REQUIRES THAT A NEW PURCHASED PART INITIATION FORM (PPIF) BE INITIATED.

(A GLOSSARY OF TERMS FOR THESE STATUS CODES CAN BE FOUND ON PAGE 0-10).

CONVERSION TABLE

INCH FRACTIONS AND DECIMALS TO MILLIMETER EQUIVALENTS

INCHES			INCHES			INCHES			INCHES		
FRACTION	DECIMAL	mm	FRACTION	DECIMAL	mm	FRACTION	DECIMAL	mm	FRACTION	DECIMAL	mm
---	.0004	.010	---	.3000	7.620	---	.7874	20.000	---	1.969	50.000
---	.0010	.025	5/16	.3125	7.938	51/64	.7969	20.241	2	2.000	50.800
---	.0039	.100	---	.3150	8.000	13/16	.8125	20.638	2-1/8	2.125	54.000
---	.0050	.127	21/64	.3281	8.334	---	.8268	21.000	---	2.165	55.000
---	.0079	.200	---	.3346	8.500	53/64	.8281	21.034	2-1/4	2.250	57.200
---	.0098	.250	11/32	.3438	8.731	27/32	.8438	21.431	---	2.362	60.000
---	.0100	.254	---	.3543	9.000	55/64	.8594	21.828	2-3/8	2.375	60.300
---	.0118	.300	23/64	.3594	9.128	---	.8662	22.000	2-1/2	2.500	63.500
1/64	.0156	.397	---	.3740	9.500	7/8	.8750	22.225	---	2.559	65.000
---	.0157	.400	3/8	.3750	9.525	57/64	.8906	22.622	2-5/8	2.625	66.700
---	.0197	.500	25/64	.3906	9.922	---	.9000	22.860	2-3/4	2.750	69.900
---	.0236	.600	---	.3937	10.000	---	.9055	23.000	---	2.756	70.000
---	.0250	.635	---	.4000	10.160	29/32	.9063	23.019	2-7/8	2.875	73.000
---	.0276	.700	13/32	.4062	10.319	59/64	.9219	23.416	---	2.953	75.000
---	.0295	.750	---	.4134	10.500	15/16	.9375	23.813	3	3.000	76.200
1/32	.0313	.794	27/64	.4219	10.716	---	.9449	24.000	---	3.150	80.000
---	.0315	.800	---	.4331	11.000	61/64	.9531	24.209	3-1/4	3.250	82.600
---	.0354	.900	7/16	.4375	11.113	31/32	.9688	24.606	---	3.346	85.000
---	.0394	1.000	29/64	.4531	11.509	---	.9843	25.000	3-1/2	3.500	88.900
3/64	.0469	1.191	15/32	.4688	11.906	1	1.0000	25.400	---	3.543	90.000
---	.0472	1.200	---	.4724	12.000	---	1.0240	26.000	---	3.740	95.000
---	.0500	1.270	31/64	.4844	12.303	1-1/16	1.0620	26.988	3-3/4	3.750	95.300
---	.0551	1.400	---	.4921	12.500	---	1.0630	27.000	---	3.937	100.000
---	.0591	1.500	1/2	.5000	12.700	---	1.1020	28.000	4	4.000	101.600
1/16	.0625	1.588	---	.5118	13.000	1-1/8	1.1250	28.575	---	4.331	110.000
---	.0669	1.700	33/64	.5156	13.097	---	1.1420	29.000	4-1/2	4.500	114.300
---	.0750	1.905	17/32	.5326	13.494	---	1.1810	30.000	---	4.724	120.000
5/64	.0781	1.984	---	.5315	13.500	1-3/16	1.1880	30.160	5	5.000	127.000
---	.0787	2.000	35/64	.5469	13.891	---	1.2210	31.000	---	5.118	130.000
---	.0906	2.300	---	.5512	14.000	1-1/4	1.2500	31.750	5-1/2	5.500	139.700
3/32	.0938	2.381	9/16	.5625	14.288	---	1.2600	32.000	---	5.512	140.000
---	.0984	2.500	---	.5710	14.500	---	1.2990	33.000	---	5.906	150.000
---	.1000	2.540	37/64	.5781	14.684	1-5/16	1.3120	33.340	6	6.000	152.400
---	.1024	2.600	---	.5906	15.000	---	1.3390	34.000	---	6.299	160.000
7/64	.1093	2.776	19/32	.5938	15.081	1-3/8	1.3750	34.930	6-1/2	6.500	165.100
---	.1181	3.000	---	.6000	15.240	---	1.3780	35.000	7	7.000	177.800
1/8	.1250	3.175	39/64	.6094	15.478	---	1.4170	36.000	---	7.087	180.000
---	.1378	3.500	---	.6103	15.500	1-7/16	1.4380	36.510	7-1/2	7.500	190.500
9/64	.1406	3.572	5/8	.6250	15.875	---	1.4570	37.000	---	7.874	200.000
5/32	.1563	3.969	---	.6299	16.000	---	1.4960	38.000	8	8.000	203.200
---	.1575	4.000	41/64	.6406	16.272	1-1/2	1.5000	38.100	8-1/2	8.500	215.900
11/64	.1719	4.366	---	.6496	16.500	---	1.5350	39.000	---	8.661	220.000
---	.1772	4.500	21/32	.6563	16.669	1-9/16	1.5620	39.690	9	9.000	228.600
3/16	.1875	4.763	---	.6693	17.000	---	1.5750	40.000	---	9.449	240.000
---	.1969	5.000	43/64	.6719	17.066	---	1.6140	41.000	9-1/2	9.500	241.300
---	.2000	5.080	11/16	.6875	17.463	1-5/8	1.6250	41.280	---	9.843	250.000
13/64	.2031	5.159	---	.6890	17.500	---	1.6540	42.000	10	10.000	254.000
---	.2165	5.500	---	.7000	17.780	1-11/16	1.6880	42.860	---	10.236	260.000
7/32	.2188	5.556	45/64	.7031	17.859	---	1.6930	43.000	11	11.000	279.400
15/64	.2344	5.953	---	.7087	18.000	---	1.7320	44.000	---	11.024	280.000
---	.2362	6.000	23/32	.7188	18.256	1-3/4	1.7500	44.450	---	11.811	300.000
1/4	.2500	6.350	---	.7283	18.500	---	1.7720	45.000	12	12.000	304.800
---	.2559	6.500	47/64	.7344	18.653	---	1.8110	46.000	13	13.000	330.200
17/64	.2656	6.747	---	.7480	19.000	1-13/16	1.8130	46.040	---	13.780	350.000
---	.2756	7.000	3/4	.7500	19.050	---	1.8500	47.000	14	14.000	355.600
9/32	.2813	7.144	49/64	.7656	19.447	1-7/8	1.8750	47.630	15	15.000	381.000
---	.2953	7.500	---	.7677	19.500	---	1.8900	48.000	---	15.748	400.000
19/64	.2969	7.541	25/32	.7813	19.844	---	1.9290	49.000	16	16.000	406.400

MATERIALS CATALOG PART NUMBER INDEX

THIS IS AN INDEX TO THIS CATALOG

PART NUMBER	PAGE NO.	PART NUMBER	PAGE NO.	PART NUMBER	PAGE NO.	PART NUMBER	PAGE NO.
002-0019-00	4-6	006-1020-00	5-5	006-2056-00	5-4	006-2905-00	5-5
002-0077-00	5-5	006-1021-00	5-5	006-2118-00	5-7	006-2932-00	4-7
002-0083-00	5-5	006-1022-00	5-5	006-2152-00	5-7	006-2954-00	4-6
002-0084-00	5-5	006-1023-00	5-5	006-2196-00	4-6	006-2958-00	5-5
002-0086-00	5-5	006-1024-00	5-5	006-2196-01	4-6	006-2971-00	4-6
002-0147-00	2-7	006-1025-00	5-5	006-2206-00	Sect. 2 Index	006-2977-00	2-6
002-1415-00	4-6	006-1026-00	5-5	006-2207-00	5-7	006-2979-00	2-7
004-0001-00	Sect. 5 Index	006-1027-00	5-5	006-2302-00	5-5	006-2980-00	2-7
006-0006-00	5-5	006-1028-00	5-5	006-2302-01	5-5	006-2987-00	2-6
006-0009-00	5-4	006-1029-00	5-5	006-2313-00	4-6	006-2993-00	5-5
006-0011-00	5-7	006-1037-00	5-4	006-2314-00	4-6	006-2994-00	5-5
006-0013-00	5-7	006-1039-00	4-4	006-2366-00	4-6	006-2995-00	5-5
006-0027-00	5-2	006-1042-00	4-8	006-2381-00	5-4	006-3141-00	5-5
006-0034-00	5-4	006-1043-00	4-8	006-2389-00	4-7	006-3148-00	4-7
006-0085-00	5-4	006-1069-00	4-3	006-2390-00	Sect. 4 Index	006-3149-00	4-7
006-0098-00	5-2	006-1085-00	2-5	006-2414-00	4-8	006-3157-00	5-7
006-0116-00	4-3	006-1097-00	5-4	006-2458-00	4-6	006-3158-00	Sect. 5 Index
006-0145-00	5-7	006-1098-00	4-6	006-2475-00	5-3	006-3164-00	4-6
006-0147-00	5-7	006-1103-00	5-7	006-2517-00	4-6	006-3167-00	5-7
006-0170-00	5-4	006-1142-00	4-8	006-2525-00	5-7	006-3178-00	5-4
006-0172-00	Sect. 5 Index	006-1161-00	5-4	006-2531-00	5-7	006-3190-00	Sect. 2 Index
006-0173-01	5-4	006-1165-00	5-4	006-2548-00	5-4	006-3198-00	5-5
006-0211-00	2-5	006-1171-00	5-5	006-2549-00	5-4	006-3217-00	4-6
006-0212-00	2-5	006-1171-01	5-5	006-2550-00	5-4	006-3222-00	5-4
006-0213-00	2-5	006-1171-02	Sect. 5 Index	006-2564-00	5-5	006-3223-00	5-4
006-0217-00	4-6	006-1171-03	5-5	006-2570-00	4-6	006-3272-00	5-7
006-0219-00	5-7	006-1178-00	4-6	006-2574-00	5-7	006-3380-00	5-4
006-0314-00	4-3	006-1189-00	5-5	006-2579-00	4-6	006-3402-00	5-3
006-0315-00	5-7	006-1190-00	5-5	006-2597-00	5-3	006-3411-00	4-6
006-0353-00	5-3	006-1193-01	1-33	006-2598-00	5-5	006-3424-00	2-8
006-0361-00	5-4	006-1214-01	5-3	006-2611-00	5-5	006-3446-00	5-3
006-0365-00	5-5	006-1215-01	5-3	006-2612-00	5-5	006-3449-00	5-3
006-0367-00	4-6	006-1217-00	4-6	006-2621-00	Sect. 14 Index	006-3450-00	5-3
006-0367-01	4-6	006-1223-00	Sect. 5 Index	006-2622-00	14-3	006-3451-00	5-3
006-0432-00	5-2	006-1242-00	5-5	006-2623-00	14-3	006-3452-00	5-3
006-0435-00	5-5	006-1257-00	5-4	006-2624-00	14-3	006-3453-00	5-3
006-0438-00	3-4	006-1259-00	Sect. 4 Index	006-2625-00	Sect. 14 Index	006-3454-00	5-3
006-0455-00	5-4	006-1353-00	5-7	006-2626-00	14-3	006-3455-00	5-3
006-0458-00	5-4	006-1356-00	12-8	006-2627-00	14-3	006-3456-00	5-3
006-0464-00	4-7	006-1433-00	5-4	006-2628-00	14-3	006-3457-00	5-3
006-0500-00	5-4	006-1437-00	Sect. 5 Index	006-2629-00	Sect. 14 Index	006-3458-00	5-3
006-0502-00	5-4	006-1441-00	5-5	006-2630-00	14-3	006-3459-00	5-3
006-0532-00	4-6	006-1548-00	Sect. 5 Index	006-2631-00	14-3	006-3460-00	5-3
006-0533-00	4-6	006-1595-00	5-5	006-2632-00	14-3	006-3461-00	5-3
006-0534-00	Sect. 4 Index	006-1610-00	Sect. 6 Index	006-2633-00	14-3	006-3462-00	5-3
006-0541-00	5-6	006-1618-00	5-5	006-2634-00	14-3	006-3463-00	5-3
006-0553-00	5-4	006-1668-00	Sect. 5 Index	006-2635-00	Sect. 14 Index	006-3464-00	5-3
006-0556-00	5-4	006-1677-00	3-4	006-2636-00	14-3	006-3466-00	5-3
006-0597-00	5-4	006-1681-00	5-7	006-2637-00	14-3	006-3467-00	5-3
006-0607-00	Sect. 5 Index	006-1685-00	4-6	006-2638-00	14-3	006-3484-00	4-7
006-0611-00	5-3	006-1703-00	5-4	006-2639-00	14-3	006-3485-00	4-7
006-0613-00	5-4	006-1748-00	5-3	006-2640-00	14-3	006-3492-00	5-7
006-0616-00	5-4	006-1749-00	5-3	006-2641-00	14-3	006-3493-00	4-7
006-0617-00	5-7	006-1757-00	4-6	006-2642-00	Sect. 14 Index	006-3499-00	4-8
006-0618-00	5-7	006-1791-00	5-2	006-2643-00	Sect. 14 Index	006-3581-00	5-4
006-0639-00	Sect. 4 Index	006-1792-00	2-5	006-2644-00	Sect. 14 Index	006-3638-00	4-6
006-0642-00	Sect. 5 Index	006-1793-00	2-5	006-2645-00	14-3	006-3639-00	4-7
006-0663-00	12-8	006-1796-00	2-5	006-2646-00	Sect. 14 Index	006-3640-00	4-7
006-0664-00	12-8	006-1799-00	4-3	006-2647-00	Sect. 14 Index	006-3684-00	5-7
006-0674-00	4-2	006-1821-00	5-3	006-2648-00	Sect. 14 Index	006-4379-00	4-6
006-0675-00	4-2	006-1825-00	Sect. 5 Index	006-2649-00	Sect. 14 Index	006-4380-00	4-6
006-0682-00	4-3	006-1832-00	5-4	006-2655-00	5-7	006-4381-00	4-6
006-0683-00	4-3	006-1848-00	Sect. 4 Index	006-2697-00	14-3	006-4401-00	4-6
006-0684-00	4-3	006-1849-00	Sect. 4 Index	006-2712-00	4-6	006-4402-00	4-6
006-0685-00	4-3	006-1851-00	4-7	006-2761-00	5-7	006-4403-00	4-6
006-0687-00	4-3	006-1852-00	4-7	006-2783-00	5-4	006-4404-00	4-6
006-0690-00	5-4	006-1863-00	4-3	006-2784-00	Sect. 5 Index	006-4409-00	5-7
006-0693-00	5-4	006-1864-00	4-7	006-2801-00	Sect. 4 Index	006-4466-00	4-6
006-0695-00	5-2	006-1865-00	Sect. 4 Index	006-2823-00	Sect. 4 Index	006-4536-00	5-7
006-0696-00	5-4	006-1866-00	4-7	006-2825-00	2-8	107-0019-01	2-6
006-0698-00	5-4	006-1912-00	5-5	006-2832-00	2-6	107-0021-00	2-8
006-0750-00	5-4	006-1923-00	5-5	006-2841-00	2-5	107-0022-00	2-8
006-0785-00	5-4	006-1926-00	5-4	006-2848-00	4-6	107-0023-00	2-8
006-0793-00	5-4	006-1928-00	5-4	006-2870-00	5-3	107-0037-00	2-8
006-1002-00	5-5	006-1965-00	5-5	006-2885-00	5-3	162-0592-00	2-4

MATERIALS CATALOG PART NUMBER INDEX (CONT)

THIS IS AN INDEX TO THIS CATALOG

PART NUMBER	PAGE NO.	PART NUMBER	PAGE NO.	PART NUMBER	PAGE NO.	PART NUMBER	PAGE NO.
176-0170-00	11-2	251-0070-01	Sect. 7 Index	251-0120-00	6-29	251-0204-00	6-16
176-0176-00	11-2	251-0070-02	Sect. 7 Index	251-0121-00	6-6	251-0205-00	6-2
176-0243-00	12-6	251-0070-03	Sect. 7 Index	251-0125-00	7-5	251-0206-00	6-10
176-0261-00	12-6	251-0070-04	7-4	251-0125-01	7-2	251-0207-00	7-4
204-0460-00	3-6	251-0071-00	7-5	251-0126-00	6-2	251-0209-00	7-3
204-0462-01	3-6	251-0072-00	7-5	251-0127-00	7-3	251-0210-00	7-6
204-0462-02	3-6	251-0072-01	7-5	251-0128-00	6-19	251-0210-02	Sect. 7 Index
204-0466-00	3-6	251-0073-00	7-5	251-0129-00	7-3	251-0213-00	7-2
204-0486-00	3-6	251-0073-01	7-4	251-0130-00	7-4	251-0214-00	7-3
204-0486-02	3-6	251-0073-02	7-4	251-0131-00	7-6	251-0216-00	6-14
204-0488-00	3-6	251-0073-03	Sect. 7 Index	251-0134-00	6-12	251-0217-00	6-12
204-0488-01	3-6	251-0073-04	7-4	251-0136-00	7-6	251-0218-00	6-15
204-0488-02	3-6	251-0073-05	7-4	251-0137-01	6-15	251-0219-00	6-15
204-0499-00	3-6	251-0073-06	7-4	251-0140-00	6-3	251-0220-00	7-5
204-0503-01	3-6	251-0073-07	7-4	251-0141-00	7-5	251-0220-01	Sect. 7 Index
204-0511-00	3-6	251-0073-08	Sect. 7 Index	251-0141-01	7-5	251-0220-02	7-5
204-0512-00	3-6	251-0073-09	7-4	251-0141-02	7-5	251-0220-03	7-5
204-0519-00	3-6	251-0073-10	7-2	251-0144-00	6-2	251-0220-06	Sect. 7 Index
204-0537-00	3-6	251-0074-00	7-3	251-0145-00	7-5	251-0220-07	7-5
204-0541-00	3-6	251-0075-00	7-5	251-0146-00	7-4	251-0220-08	7-5
204-0585-00	3-6	251-0075-01	7-4	251-0147-00	7-4	251-0220-09	7-5
204-0586-00	3-6	251-0075-02	7-4	251-0148-00	7-2	251-0221-00	7-3
204-0603-00	3-6	251-0075-03	7-2	251-0150-00	6-3	251-0222-00	7-2
204-0604-00	3-6	251-0075-04	7-4	251-0151-00	7-4	251-0223-00	7-3
204-0611-00	3-6	251-0075-06	7-4	251-0152-00	7-3	251-0224-00	6-10
204-0651-00	3-6	251-0075-07	7-4	251-0153-00	7-6	251-0225-00	7-5
204-0688-00	Sect. 3 Index	251-0075-08	7-4	251-0154-00	7-2	251-0226-00	6-2
204-0702-00	3-6	251-0076-00	7-5	251-0155-00	7-6	251-0228-00	6-16
204-0710-00	3-6	251-0076-01	7-4	251-0156-00	6-21	251-0231-00	7-6
204-0778-00	3-6	251-0076-02	Sect. 7 Index	251-0158-00	7-2	251-0233-00	7-6
204-0817-00	3-6	251-0076-03	7-4	251-0160-00	6-21	251-0234-00	6-6
204-0818-00	3-6	251-0076-04	7-4	251-0161-00	6-21	251-0235-00	7-6
204-0823-00	Sect. 3 Index	251-0077-00	7-5	251-0167-00	7-6	251-0236-00	7-2
204-0861-00	3-6	251-0077-01	7-4	251-0169-00	6-6	251-0239-00	6-12
251-0002-00	6-2	251-0077-02	7-4	251-0171-00	6-6	251-0240-00	6-6
251-0004-00	6-2	251-0077-03	7-4	251-0174-00	7-2	251-0242-00	6-2
251-0005-00	7-2	251-0077-04	7-4	251-0175-00	7-2	251-0245-00	6-2
251-0006-00	7-2	251-0077-05	7-4	251-0176-00	6-12	251-0246-00	7-6
251-0009-00	7-2	251-0078-00	7-5	251-0177-00	6-35	251-0248-00	7-3
251-0010-00	7-2	251-0078-01	7-5	251-0179-00	7-5	251-0249-00	7-3
251-0011-00	7-2	251-0078-02	7-5	251-0179-01	7-4	251-0250-00	7-4
251-0015-00	7-2	251-0078-03	7-4	251-0179-02	7-4	251-0251-00	6-2
251-0016-00	7-2	251-0078-04	7-4	251-0179-03	7-4	251-0252-00	6-16
251-0019-00	7-2	251-0078-05	7-4	251-0180-00	7-5	251-0253-00	7-2
251-0020-00	7-2	251-0078-06	7-4	251-0180-01	7-4	251-0254-00	7-2
251-0021-00	7-2	251-0081-00	7-3	251-0180-02	7-5	251-0255-00	7-2
251-0022-00	7-2	251-0083-00	6-22	251-0180-03	7-4	251-0256-00	Sect. 6 Index
251-0023-00	7-2	251-0085-00	7-6	251-0180-04	7-4	251-0257-00	6-16
251-0024-00	7-2	251-0086-00	7-4	251-0182-00	7-5	251-0258-00	6-21
251-0025-00	7-3	251-0087-00	7-2	251-0182-01	Sect. 7 Index	251-0260-00	6-12
251-0026-00	7-3	251-0088-00	6-18	251-0182-02	7-4	251-0261-00	6-4
251-0027-00	7-3	251-0089-00	7-6	251-0182-03	7-4	251-0262-00	6-3
251-0028-00	7-5	251-0090-00	6-6	251-0183-00	6-10	251-0264-00	6-3
251-0031-00	7-5	251-0092-00	Sect. 6 Index	251-0185-00	6-17	251-0265-00	6-3
251-0034-00	7-5	251-0096-00	7-6	251-0186-00	6-19	251-0266-00	6-3
251-0036-00	7-5	251-0097-00	6-15	251-0189-00	6-17	251-0267-00	6-6
251-0038-00	7-5	251-0098-00	6-9	251-0190-00	Sect. 6 Index	251-0268-00	6-6
251-0039-00	7-6	251-0099-00	7-6	251-0191-00	6-2	251-0269-00	6-6
251-0040-00	7-6	251-0100-00	7-5	251-0192-00	6-3	251-0270-00	6-6
251-0041-00	7-6	251-0101-00	7-2	251-0193-00	6-9	251-0271-00	Sect. 7 Index
251-0042-00	7-6	251-0102-00	6-16	251-0194-00	6-6	251-0271-03	7-5
251-0043-00	7-6	251-0103-00	7-2	251-0195-00	7-5	251-0271-04	7-5
251-0044-00	7-6	251-0104-00	6-17	251-0196-00	7-5	251-0271-05	7-5
251-0048-00	Sect. 6 Index	251-0106-00	6-29	251-0196-01	Sect. 7 Index	251-0271-06	7-5
251-0049-00	6-2	251-0108-00	7-5	251-0196-02	7-4	251-0275-00	6-10
251-0053-00	7-4	251-0109-00	7-2	251-0196-03	7-4	251-0276-00	6-10
251-0054-00	7-2	251-0112-00	7-6	251-0196-05	Sect. 7 Index	251-0277-00	6-12
251-0055-00	7-4	251-0113-00	7-5	251-0197-00	6-3	251-0278-00	6-12
251-0056-00	7-4	251-0113-01	7-5	251-0198-00	6-20	251-0279-00	6-12
251-0057-00	7-4	251-0113-02	7-5	251-0200-00	7-4	251-0281-00	7-2
251-0061-00	6-30	251-0114-00	7-5	251-0201-00	6-35	251-0282-00	6-19
251-0066-00	7-5	251-0115-00	6-22	251-0202-00	7-5	251-0283-00	6-12
251-0067-00	6-3	251-0117-00	6-6	251-0202-01	7-4	251-0284-00	7-3
251-0069-00	6-2	251-0118-00	6-3	251-0202-02	Sect. 7 Index	251-0285-00	7-6
251-0070-00	7-5	251-0119-00	6-2	251-0202-03	7-4	251-0286-00	7-2

MATERIALS CATALOG PART NUMBER INDEX (CONT)

THIS IS AN INDEX TO THIS CATALOG

PART NUMBER	PAGE NO.	PART NUMBER	PAGE NO.	PART NUMBER	PAGE NO.	PART NUMBER	PAGE NO.
251-0287-00	7-3	251-0341-00	10-2	251-0432-00	9-3	251-0486-00	8-3
251-0289-00	7-3	251-0341-01	10-2	251-0432-01	Sect. 9 Index	251-0487-00	9-2
251-0290-00	6-3	251-0342-00	Sect. 8 Index	251-0433-00	8-3	251-0488-00	11-2
251-0291-00	6-6	251-0342-01	8-2	251-0435-00	8-5	251-0489-00	8-4
251-0292-00	6-18	251-0342-02	8-2	251-0436-00	Sect. 11 Index	251-0489-01	Sect. 8 Index
251-0293-00	6-10	251-0343-00	8-2	251-0437-00	8-5	251-0490-00	9-3
251-0295-00	7-6	251-0345-00	8-2	251-0439-00	9-3	251-0490-01	Sect. 9 Index
251-0296-00	7-3	251-0350-00	8-2	251-0439-01	9-2	251-0490-03	9-3
251-0298-00	6-3	251-0351-00	8-5	251-0439-02	9-3	251-0491-00	8-3
251-0299-00	6-3	251-0353-00	11-2	251-0440-00	8-4	251-0492-00	8-5
251-0300-00	6-20	251-0353-01	11-2	251-0441-00	8-3	251-0493-00	9-2
251-0301-00	8-2	251-0353-02	11-2	251-0442-00	9-3	251-0494-00	8-2
251-0302-00	8-3	251-0353-03	11-2	251-0442-01	9-3	251-0495-00	8-3
251-0303-00	8-3	251-0358-00	8-5	251-0442-02	9-3	251-0496-00	8-3
251-0304-00	8-3	251-0361-00	11-2	251-0444-00	Sect. 12 Index	251-0498-00	9-2
251-0305-00	8-3	251-0362-00	10-2	251-0444-02	Sect. 12 Index	251-0499-00	8-3
251-0306-00	8-2	251-0362-01	10-2	251-0444-04	Sect. 12 Index	251-0501-00	15-4
251-0307-00	8-2	251-0363-00	8-4	251-0444-05	Sect. 12 Index	251-0503-00	14-3
251-0308-00	8-2	251-0365-00	11-2	251-0444-06	Sect. 12 Index	251-0504-00	Sect. 14 Index
251-0309-00	8-2	251-0365-01	Sect. 11 Index	251-0444-07	Sect. 12 Index	251-0506-00	14-2
251-0310-00	8-3	251-0366-00	10-2	251-0445-00	8-2	251-0507-00	15-2
251-0311-00	8-3	251-0367-00	10-2	251-0446-00	8-2	251-0508-00	12-5
251-0312-00	8-3	251-0368-00	8-5	251-0447-00	Sect. 9 Index	251-0509-00	12-8
251-0313-00	8-3	251-0369-00	9-3	251-0448-00	10-2	251-0511-00	12-8
251-0314-00	8-3	251-0370-00	11-2	251-0448-01	10-2	251-0512-00	12-8
251-0315-00	8-4	251-0373-00	8-2	251-0448-02	10-2	251-0513-00	12-8
251-0315-01	8-4	251-0374-00	Sect. 10 Index	251-0448-03	10-2	251-0514-00	12-8
251-0315-02	8-4	251-0378-01	9-3	251-0448-04	10-2	251-0515-00	12-8
251-0315-03	8-4	251-0378-02	9-2	251-0448-05	10-2	251-0516-00	14-3
251-0315-04	8-2	251-0378-03	9-2	251-0448-06	10-2	251-0517-00	15-4
251-0315-05	8-2	251-0378-04	9-3	251-0448-07	10-2	251-0518-00	15-3
251-0315-06	8-2	251-0378-06	Sect. 9 Index	251-0451-00	9-3	251-0522-00	Sect. 8 Index
251-0315-07	8-4	251-0378-07	9-3	251-0451-01	9-3	251-0525-00	Sect. 9 Index
251-0316-00	8-4	251-0380-00	8-2	251-0451-02	9-3	251-0526-00	14-2
251-0316-01	8-4	251-0382-00	8-2	251-0451-03	9-3	251-0528-00	14-3
251-0316-02	8-4	251-0383-00	10-2	251-0451-04	Sect. 9 Index	251-0528-01	Sect. 14 Index
251-0316-03	8-2	251-0385-00	10-2	251-0451-06	9-3	251-0528-02	14-2
251-0316-04	8-2	251-0389-00	8-5	251-0453-00	8-2	251-0528-03	14-2
251-0316-05	8-2	251-0391-00	8-2	251-0454-00	8-2	251-0528-04	14-2
251-0317-00	8-4	251-0393-00	8-5	251-0457-00	8-3	251-0529-00	14-3
251-0317-01	8-2	251-0394-00	8-3	251-0459-00	8-5	251-0530-00	14-3
251-0317-02	8-4	251-0397-00	Sect. 10 Index	251-0462-00	9-3	251-0531-00	15-4
251-0318-00	8-4	251-0399-00	8-2	251-0462-01	9-3	251-0532-00	Sect. 15 Index
251-0319-00	8-5	251-0400-00	9-2	251-0462-02	9-2	251-0533-00	14-2
251-0321-00	8-5	251-0400-01	9-2	251-0462-03	9-3	251-0534-00	Sect. 12 Index
251-0323-00	8-5	251-0400-02	Sect. 9 Index	251-0462-05	9-2	251-0535-00	Sect. 15 Index
251-0325-00	10-2	251-0401-00	9-2	251-0464-00	10-2	251-0538-00	15-3
251-0326-00	Sect. 8 Index	251-0401-01	9-3	251-0464-01	Sect. 10 Index	251-0539-00	15-3
251-0328-00	8-2	251-0402-00	8-5	251-0464-03	Sect. 10 Index	251-0539-01	15-3
251-0330-00	11-2	251-0403-00	8-3	251-0464-04	10-2	251-0540-00	14-3
251-0330-04	11-2	251-0404-00	8-5	251-0464-05	Sect. 10 Index	251-0540-01	14-3
251-0331-00	8-2	251-0405-00	8-5	251-0465-00	9-3	251-0541-00	14-2
251-0332-00	8-5	251-0406-00	9-2	251-0465-01	9-2	251-0542-00	15-3
251-0333-00	8-4	251-0406-01	Sect. 9 Index	251-0465-02	9-2	251-0543-00	14-3
251-0333-01	8-2	251-0411-00	Sect. 10 Index	251-0465-03	9-2	251-0544-00	14-2
251-0333-02	8-2	251-0412-00	9-2	251-0465-05	9-3	251-0545-00	12-8
251-0333-03	8-4	251-0412-01	9-2	251-0466-00	11-2	251-0545-01	12-8
251-0333-06	8-4	251-0412-02	9-2	251-0466-01	Sect. 11 Index	251-0551-00	12-8
251-0333-07	8-4	251-0412-03	9-3	251-0466-02	11-2	251-0552-00	Sect. 12 Index
251-0333-08	8-2	251-0412-04	9-3	251-0467-00	Sect. 8 Index	251-0554-00	15-4
251-0333-09	8-2	251-0412-06	9-3	251-0468-00	9-2	251-0555-00	12-5
251-0333-10	8-4	251-0413-00	8-4	251-0468-01	9-3	251-0556-00	14-3
251-0335-00	10-2	251-0414-00	8-3	251-0468-02	9-2	251-0557-00	14-3
251-0335-01	10-2	251-0416-00	11-2	251-0468-03	9-2	251-0559-00	14-2
251-0335-04	10-2	251-0417-00	11-2	251-0471-00	9-2	251-0560-00	Sect. 12 Index
251-0337-00	8-5	251-0418-00	11-2	251-0472-00	10-2	251-0561-00	Sect. 12 Index
251-0338-00	11-2	251-0419-00	12-5	251-0473-00	Sect. 8 Index	251-0562-00	15-4
251-0338-01	11-2	251-0419-01	12-5	251-0476-00	8-3	251-0563-00	15-4
251-0338-02	11-2	251-0420-00	11-2	251-0478-00	9-2	251-0563-02	15-2
251-0338-03	11-2	251-0423-00	8-5	251-0479-00	8-5	251-0567-00	15-4
251-0338-04	Sect. 11 Index	251-0424-00	8-5	251-0480-00	8-5	251-0568-00	15-2
251-0339-00	8-3	251-0426-00	8-3	251-0481-00	Sect. 8 Index	251-0569-00	15-2
251-0340-00	Sect. 10 Index	251-0427-00	8-5	251-0482-00	8-3	251-0570-00	12-5
251-0340-01	10-2	251-0428-00	8-5	251-0484-00	8-5	251-0571-00	15-4
251-0340-02	10-2	251-0430-00	8-2	251-0485-00	8-2	251-0572-00	15-4

MATERIALS CATALOG PART NUMBER INDEX (CONT)

THIS IS AN INDEX TO THIS CATALOG

PART NUMBER	PAGE NO.	PART NUMBER	PAGE NO.	PART NUMBER	PAGE NO.	PART NUMBER	PAGE NO.
251-0573-00	15-4	251-0689-00	15-5	251-0773-00	15-4	251-0851-00	Sect. 14 Index
251-0574-00	15-4	251-0689-01	15-5	251-0774-00	15-3	251-0854-00	12-5
251-0577-00	15-4	251-0690-00	14-2	251-0775-00	15-2	251-0855-00	15-2
251-0578-00	15-2	251-0691-00	12-8	251-0775-01	15-2	251-0861-00	13-2
251-0579-00	15-4	251-0694-00	15-2	251-0776-00	15-2	251-0862-00	15-2
251-0581-00	15-3	251-0695-00	15-5	251-0778-00	12-8	251-0863-00	15-2
251-0589-00	Sect. 14 Index	251-0696-00	15-2	251-0780-00	14-2	251-0864-00	15-3
251-0590-00	14-3	251-0697-00	14-3	251-0781-00	Sect. 15 Index	251-0865-00	14-2
251-0591-00	13-3	251-0698-00	14-3	251-0781-01	15-4	251-0866-00	14-2
251-0598-00	15-3	251-0699-00	15-3	251-0781-02	15-2	251-0867-00	15-3
251-0599-00	14-2	251-0700-00	15-3	251-0782-00	Sect. 15 Index	251-0869-00	14-3
251-0601-00	14-2	251-0701-00	15-3	251-0783-00	Sect. 15 Index	251-0869-01	14-2
251-0603-00	15-2	251-0702-00	12-5	251-0784-00	14-2	251-0870-00	14-2
251-0604-00	15-4	251-0704-00	15-4	251-0785-00	12-8	251-0871-00	Sect. 14 Index
251-0611-00	15-5	251-0706-00	15-4	251-0786-00	12-8	251-0872-00	12-5
251-0615-00	15-4	251-0707-00	Sect. 15 Index	251-0787-00	12-8	251-0873-00	15-5
251-0616-00	15-4	251-0708-00	15-3	251-0788-00	15-4	251-0874-00	13-3
251-0617-00	15-3	251-0709-00	15-4	251-0789-00	15-5	251-0875-00	15-3
251-0618-00	14-2	251-0711-00	15-3	251-0790-01	15-5	251-0877-00	14-2
251-0619-00	14-3	251-0711-01	Sect. 15 Index	251-0790-02	15-5	251-0880-00	15-3
251-0619-02	14-2	251-0712-00	13-2	251-0790-03	15-5	251-0882-00	Sect. 15 Index
251-0619-03	14-2	251-0714-00	15-3	251-0792-00	15-3	251-0883-00	15-3
251-0620-00	14-3	251-0714-01	Sect. 15 Index	251-0793-00	15-3	251-0884-00	Sect. 14 Index
251-0620-01	Sect. 14 Index	251-0715-00	15-3	251-0796-00	15-4	251-0885-00	Sect. 14 Index
251-0622-00	Sect. 14 Index	251-0718-00	15-4	251-0797-00	15-4	251-0886-00	13-2
251-0623-00	14-2	251-0718-01	15-4	251-0797-01	15-4	251-0887-00	14-3
251-0624-00	15-2	251-0719-00	15-2	251-0798-00	15-4	251-0889-00	14-3
251-0624-01	15-4	251-0720-00	15-2	251-0799-00	Sect. 15 Index	251-0890-00	15-3
251-0625-00	15-3	251-0721-00	15-4	251-0800-00	14-3	251-0890-02	15-3
251-0626-00	15-3	251-0723-00	14-2	251-0801-00	15-4	251-0891-00	14-2
251-0627-00	15-4	251-0724-00	12-8	251-0801-01	Sect. 15 Index	251-0892-00	15-3
251-0628-00	15-4	251-0726-00	14-2	251-0802-00	15-4	251-0893-00	15-5
251-0629-00	15-4	251-0727-00	15-2	251-0804-01	12-8	251-0894-00	15-4
251-0630-00	14-2	251-0728-00	15-3	251-0805-00	15-4	251-0895-00	Sect. 14 Index
251-0631-00	15-3	251-0729-00	15-2	251-0806-00	12-8	251-0897-00	15-4
251-0633-00	Sect. 15 Index	251-0729-01	15-2	251-0807-00	Sect. 12 Index	251-0898-00	12-5
251-0634-00	15-4	251-0729-03	15-4	251-0807-01	12-8	251-0899-00	14-2
251-0635-00	15-2	251-0730-00	15-2	251-0808-00	15-2	251-0900-00	12-8
251-0639-00	15-3	251-0731-00	15-2	251-0809-00	15-4	251-0901-00	15-2
251-0639-01	15-3	251-0732-00	15-2	251-0810-00	15-3	251-0902-00	12-5
251-0640-00	15-3	251-0733-00	15-5	251-0811-00	14-3	251-0903-00	Sect. 15 Index
251-0643-00	15-4	251-0734-00	Sect. 14 Index	251-0813-00	15-4	251-0904-00	15-3
251-0644-00	15-2	251-0736-00	12-5	251-0814-00	14-2	251-0906-00	15-2
251-0646-00	14-2	251-0737-00	12-5	251-0815-00	14-2	251-0910-00	14-2
251-0648-00	12-8	251-0738-00	12-8	251-0817-00	13-2	251-0911-00	Sect. 14 Index
251-0649-00	15-2	251-0740-00	12-5	251-0817-02	13-2	251-0912-00	14-3
251-0651-00	Sect. 12 Index	251-0741-00	14-2	251-0818-00	15-4	251-0913-00	14-3
251-0652-00	15-5	251-0742-00	15-3	251-0819-00	12-5	251-0915-00	12-8
251-0653-00	12-8	251-0743-00	15-5	251-0821-00	12-8	251-0917-00	15-2
251-0656-00	15-4	251-0744-00	15-5	251-0822-00	12-8	251-0918-00	15-5
251-0657-00	15-2	251-0745-00	12-5	251-0823-00	8-5	251-0919-00	15-3
251-0660-00	15-4	251-0746-00	15-2	251-0824-00	15-5	251-0920-00	14-2
251-0662-00	15-2	251-0747-00	15-2	251-0824-01	15-5	251-0921-00	Sect. 14 Index
251-0663-00	15-4	251-0748-00	14-2	251-0826-00	Sect. 15 Index	251-0922-00	15-4
251-0664-00	14-3	251-0749-00	Sect. 14 Index	251-0827-00	15-5	251-0923-00	15-4
251-0667-00	14-2	251-0750-00	15-3	251-0828-00	15-2	251-0924-00	Sect. 14 Index
251-0668-00	14-2	251-0751-00	15-3	251-0830-00	15-5	251-0925-00	14-2
251-0669-00	Sect. 15 Index	251-0752-00	12-8	251-0832-00	15-2	251-0927-00	15-2
251-0670-00	15-3	251-0753-00	14-2	251-0833-00	12-5	251-0928-00	14-2
251-0672-00	15-4	251-0754-00	Sect. 15 Index	251-0834-00	14-3	251-0929-00	14-3
251-0673-00	15-4	251-0755-00	15-2	251-0835-00	15-2	251-0931-00	Sect. 14 Index
251-0674-00	15-5	251-0757-00	15-3	251-0836-00	15-3	251-0932-00	14-2
251-0676-00	14-2	251-0759-00	14-2	251-0837-00	14-2	251-0933-00	12-8
251-0677-00	14-3	251-0760-00	12-5	251-0838-00	Sect. 12 Index	251-0934-00	14-2
251-0678-00	14-3	251-0761-00	15-2	251-0839-00	15-2	251-0935-00	14-2
251-0678-01	14-2	251-0762-00	15-5	251-0840-00	12-5	251-0936-00	14-2
251-0680-00	12-4	251-0763-00	15-4	251-0841-00	12-3	251-0937-00	14-2
251-0681-00	14-2	251-0764-00	15-4	251-0842-00	14-2	251-0959-00	13-3
251-0682-00	12-8	251-0765-00	15-2	251-0843-00	15-2	251-0960-00	15-2
251-0683-00	12-8	251-0766-00	15-4	251-0844-00	15-4	251-0963-00	12-8
251-0684-00	15-3	251-0767-00	Sect. 14 Index	251-0845-00	15-2	251-0964-00	Sect. 12 Index
251-0685-00	Sect. 15 Index	251-0768-00	Sect. 15 Index	251-0846-00	12-5	251-0966-00	14-2
251-0686-00	15-2	251-0771-00	15-3	251-0847-00	15-2	251-0968-00	15-4
251-0687-00	15-2	251-0772-00	15-2	251-0848-00	Sect. 15 Index	251-0970-00	15-3
251-0688-00	15-2	251-0772-01	15-2	251-0850-00	12-8	251-0971-00	14-3

MATERIALS CATALOG PART NUMBER INDEX (CONT)

THIS IS AN INDEX TO THIS CATALOG

PART NUMBER	PAGE NO.	PART NUMBER	PAGE NO.	PART NUMBER	PAGE NO.	PART NUMBER	PAGE NO.
251-0972-00	15-3	251-1073-00	6-10	251-1169-00	Sect. 6 Index	251-1269-00	6-29
251-0973-00	15-3	251-1074-00	6-8	251-1170-00	6-20	251-1271-00	6-19
251-0974-00	Sect. 12 Index	251-1076-00	6-10	251-1172-00	6-2	251-1272-00	6-4
251-0975-00	14-2	251-1077-00	6-18	251-1173-00	6-19	251-1273-00	7-2
251-0978-00	15-5	251-1078-00	6-4	251-1174-00	6-13	251-1274-00	7-3
251-0983-00	14-2	251-1079-00	6-8	251-1175-00	6-13	251-1275-00	7-4
251-0984-00	15-4	251-1080-00	7-6	251-1176-00	6-16	251-1276-00	7-3
251-0985-00	14-2	251-1081-00	7-2	251-1177-00	6-7	251-1277-00	Sect. 7 Index
251-0986-00	Sect. 14 Index	251-1083-00	7-2	251-1181-00	6-2	251-1278-00	6-19
251-0987-00	15-4	251-1085-00	6-11	251-1182-00	6-4	251-1279-00	7-3
251-0988-00	Sect. 12 Index	251-1087-00	7-2	251-1183-00	6-4	251-1280-00	7-3
251-0988-01	12-8	251-1088-01	6-10	251-1184-00	6-7	251-1283-00	7-4
251-0989-00	Sect. 15 Index	251-1089-00	6-10	251-1185-00	6-14	251-1284-00	7-6
251-0990-00	12-5	251-1090-00	6-6	251-1187-00	7-6	251-1285-00	6-10
251-0991-00	15-2	251-1091-00	7-2	251-1188-00	7-2	251-1286-00	7-6
251-0992-00	15-3	251-1092-00	7-2	251-1189-00	6-4	251-1287-00	7-2
251-0993-00	15-2	251-1093-00	6-33	251-1190-00	7-5	251-1291-00	6-5
251-0994-00	12-3	251-1094-00	6-10	251-1190-01	7-4	251-1292-00	6-2
251-0995-00	15-4	251-1095-00	6-10	251-1190-02	7-5	251-1293-00	6-22
251-0996-00	12-5	251-1096-00	Sect. 7 Index	251-1191-00	6-4	251-1296-00	6-5
251-0998-00	14-2	251-1097-00	6-10	251-1192-00	6-16	251-1297-00	6-10
251-0999-00	15-2	251-1098-00	6-16	251-1193-00	6-19	251-1298-00	6-2
251-1000-00	14-3	251-1099-00	7-2	251-1194-00	6-5	251-1300-00	6-10
251-1001-00	7-2	251-1102-00	7-5	251-1195-00	6-16	251-1301-00	7-5
251-1003-00	6-2	251-1105-00	6-7	251-1196-00	6-4	251-1302-00	6-5
251-1008-00	6-2	251-1107-00	Sect. 7 Index	251-1197-00	6-4	251-1303-00	6-7
251-1009-00	6-6	251-1108-00	6-18	251-1199-00	6-35	251-1304-00	6-14
251-1010-00	6-3	251-1109-00	7-5	251-1200-00	6-19	251-1305-00	7-5
251-1015-00	6-30	251-1110-00	6-34	251-1201-00	6-19	251-1311-00	7-6
251-1015-01	6-30	251-1111-00	6-5	251-1202-00	7-2	251-1312-00	6-2
251-1018-00	7-3	251-1112-00	6-13	251-1203-00	6-21	251-1313-00	7-3
251-1019-00	7-5	251-1114-00	6-13	251-1204-00	7-3	251-1314-00	6-14
251-1019-01	7-4	251-1115-00	6-20	251-1205-00	6-16	251-1315-00	6-14
251-1019-02	7-4	251-1116-00	6-10	251-1206-00	6-16	251-1319-00	7-3
251-1019-03	7-4	251-1117-00	6-22	251-1207-00	7-2	251-1320-00	6-33
251-1020-00	6-2	251-1118-00	7-2	251-1208-00	6-5	251-1321-00	6-15
251-1021-00	Sect. 6 Index	251-1119-00	7-3	251-1209-00	6-22	251-1322-00	6-15
251-1021-01	6-27	251-1120-00	6-7	251-1210-00	6-13	251-1323-00	6-10
251-1022-00	7-4	251-1122-00	6-33	251-1211-00	7-2	251-1325-00	6-16
251-1023-00	6-12	251-1124-00	6-4	251-1212-00	7-2	251-1326-00	6-33
251-1024-00	6-12	251-1126-00	6-20	251-1220-00	6-34	251-1326-01	6-35
251-1026-00	7-6	251-1127-00	6-13	251-1221-00	6-7	251-1329-00	6-10
251-1027-00	7-2	251-1128-00	Sect. 7 Index	251-1222-00	6-8	251-1330-00	6-29
251-1029-00	6-10	251-1129-00	6-2	251-1223-00	6-19	251-1331-00	6-19
251-1030-00	6-10	251-1131-00	6-12	251-1224-00	6-21	251-1332-00	6-16
251-1032-00	6-6	251-1132-00	6-5	251-1225-00	6-17	251-1333-00	6-15
251-1033-00	6-3	251-1134-00	7-2	251-1226-00	6-7	251-1334-00	7-3
251-1034-00	6-21	251-1135-00	6-19	251-1227-00	7-5	251-1335-00	7-2
251-1035-00	6-21	251-1136-00	Sect. 6 Index	251-1227-01	7-5	251-1336-00	6-5
251-1036-00	7-6	251-1137-00	6-19	251-1229-00	6-17	251-1337-00	7-5
251-1037-00	6-6	251-1138-00	6-20	251-1231-00	6-30	251-1341-00	7-2
251-1038-00	6-36	251-1140-01	6-17	251-1233-00	6-7	251-1345-00	6-15
251-1041-00	6-3	251-1141-00	6-14	251-1234-00	Sect. 6 Index	251-1346-00	6-5
251-1042-00	6-6	251-1142-00	6-13	251-1235-00	Sect. 6 Index	251-1347-00	6-15
251-1043-00	6-6	251-1143-00	6-10	251-1236-00	6-13	251-1348-00	7-5
251-1044-00	6-12	251-1144-00	7-2	251-1237-00	6-13	251-1349-00	6-16
251-1046-00	6-4	251-1145-00	7-3	251-1239-00	7-6	251-1353-00	6-14
251-1047-00	7-4	251-1146-00	6-16	251-1240-00	7-4	251-1354-00	6-6
251-1048-00	6-34	251-1147-00	6-5	251-1241-00	Sect. 6 Index	251-1355-00	7-2
251-1049-00	6-2	251-1149-00	6-15	251-1244-00	6-10	251-1356-00	7-6
251-1052-00	6-18	251-1150-00	6-21	251-1249-00	6-8	251-1357-00	7-6
251-1054-00	6-2	251-1151-00	6-4	251-1250-00	7-4	251-1358-00	7-6
251-1055-00	Sect. 7 Index	251-1152-00	6-4	251-1251-00	7-6	251-1349-00	7-3
251-1056-00	7-5	251-1153-00	6-15	251-1252-00	6-17	251-1360-00	6-10
251-1060-00	6-19	251-1154-00	6-16	251-1253-00	7-4	251-1361-00	6-10
251-1061-00	6-33	251-1155-00	6-4	251-1258-00	6-16	251-1363-00	7-3
251-1063-00	7-5	251-1156-00	6-5	251-1259-00	6-29	251-1365-00	6-35
251-1064-00	6-8	251-1157-01	7-5	251-1260-00	6-14	251-1366-00	6-32
251-1065-00	6-16	251-1158-00	6-22	251-1261-00	6-14	251-1367-00	6-5
251-1067-00	6-4	251-1161-00	6-22	251-1262-00	6-4	251-1369-00	6-14
251-1068-00	6-30	251-1162-00	6-13	251-1263-00	6-7	251-1370-00	6-21
251-1069-00	6-8	251-1163-00	6-13	251-1264-00	6-14	251-1371-00	6-7
251-1070-00	6-29	251-1164-00	6-13	251-1265-00	6-17	251-1372-00	6-21
251-1071-00	6-17	251-1165-00	Sect. 6 Index	251-1266-00	6-17	251-1375-00	6-22
251-1072-00	6-10	251-1168-00	7-2	251-1268-00	6-13	251-1376-00	6-14

MATERIALS CATALOG PART NUMBER INDEX (CONT)

THIS IS AN INDEX TO THIS CATALOG

PART NUMBER	PAGE NO.	PART NUMBER	PAGE NO.	PART NUMBER	PAGE NO.	PART NUMBER	PAGE NO.
251-1377-00	6-33	251-1492-00	6-38	251-1585-00	6-26	251-1725-00	15-4
251-1378-00	Sect. 7 Index	251-1495-00	6-2	251-1586-00	6-37	251-1726-00	6-37
251-1380-00	6-7	251-1496-00	6-8	251-1587-00	6-37	251-1730-00	6-37
251-1381-00	7-6	251-1497-00	6-9	251-1588-00	6-31	251-3000-00	Sect. 7 Index
251-1384-00	Sect. 6 Index	251-1498-00	6-9	251-1589-00	6-24	251-3001-00	15-3
251-1385-00	Sect. 6 Index	251-1499-00	6-8	251-1591-00	6-31	251-3002-00	14-3
251-1386-00	6-16	251-1500-00	6-22	251-1592-00	6-37	251-3003-00	15-2
251-1389-00	7-3	251-1501-00	Sect. 6 Index	251-1593-00	6-24	251-3004-00	14-2
251-1390-00	6-35	251-1501-01	6-26	251-1594-00	6-10	251-3006-00	15-2
251-1391-00	Sect. 6 Index	251-1502-00	6-11	251-1595-00	Sect. 7 Index	251-3007-00	Sect. 15 Index
251-1393-00	6-16	251-1503-00	6-9	251-1596-00	7-4	251-3008-00	12-8
251-1394-00	6-8	251-1504-00	6-11	251-1597-00	6-7 & 7-3	251-3009-00	Sect. 15 Index
251-1396-00	6-5	251-1505-00	6-11	251-1598-00	6-12	251-3010-00	12-8
251-1397-00	6-21	251-1506-00	6-11	251-1599-00	6-24	251-3013-00	7-3
251-1400-00	7-6	251-1507-00	6-31	251-1600-00	6-26	251-3014-00	12-8
251-1422-00	Sect. 7 Index	251-1508-00	7-3	251-1602-00	7-3	251-3015-00	11-2
251-1423-00	6-20	251-1510-00	6-9	251-1603-00	Sect. 7 Index	251-3016-00	Sect. 15 Index
251-1424-00	6-22	251-1512-00	6-38	251-1604-00	7-2	251-3017-00	Sect. 14 Index
251-1425-00	6-5	251-1513-00	6-38	251-1605-00	6-25	251-3018-00	Sect. 15 Index
251-1426-00	Sect. 7 Index	251-1514-00	6-23	251-1606-00	6-25	251-3019-00	15-3
251-1427-00	7-2	251-1515-00	6-23	251-1607-00	7-3	251-3019-01	15-3
251-1428-00	6-14	251-1517-00	6-23	251-1608-00	6-10	251-3019-02	15-3
251-1429-00	7-2	251-1518-00	6-23	251-1611-00	6-26	251-3019-03	15-3
251-1431-00	Sect. 6 Index	251-1519-00	6-23	251-1612-00	7-3	251-3019-04	15-3
251-1433-00	6-34	251-1520-00	6-23	251-1615-00	6-25	251-3019-05	15-3
251-1434-00	6-7	251-1521-00	6-23	251-1616-00	6-17	251-3020-00	15-2
251-1435-00	6-11	251-1522-00	6-18	251-1621-00	7-5	251-3020-01	15-2
251-1436-00	7-2	251-1523-00	6-18	251-1622-00	6-36	251-3022-00	Sect. 15 Index
251-1437-00	7-2	251-1529-00	6-23	251-1624-00	6-26	251-3023-00	12-5
251-1438-00	Sect. 7 Index	251-1530-00	6-22	251-1629-00	6-26	251-3024-00	15-3
251-1439-00	7-3	251-1531-00	6-22	251-1630-00	6-26	251-3025-00	15-3
251-1440-00	7-3	251-1532-00	6-26	251-1631-00	6-27	251-3026-00	15-3
251-1440-01	7-3	251-1534-00	6-18	251-1632-00	7-2	251-3027-00	Sect. 14 Index
251-1441-00	7-3	251-1535-00	Sect. 7 Index	251-1633-00	6-2	251-3028-00	14-2
251-1442-00	Sect. 7 Index	251-1536-00	7-2	251-1635-00	6-25	251-3030-00	12-5
251-1443-00	7-2	251-1537-00	7-3	251-1636-00	6-37	251-3031-00	15-3
251-1444-00	6-14	251-1538-00	6-30	251-1637-00	6-2	251-3032-00	15-3
251-1446-00	7-5	251-1539-00	Sect. 7 Index	251-1638-00	7-3	251-3034-00	14-3
251-1447-00	6-8	251-1540-00	6-9	251-1639-00	7-3	251-3035-00	14-3
251-1448-00	Sect. 6 Index	251-1541-00	6-9	251-1640-00	6-7	251-3036-00	15-2
251-1449-00	6-22	251-1542-00	7-6	251-1641-00	7-5	251-3048-00	15-5
251-1451-00	6-10	251-1543-00	7-6	251-1641-01	7-5	251-3049-00	15-3
251-1452-00	6-28	251-1545-00	6-31	251-1642-00	7-5	251-3050-00	Sect. 7 Index
251-1453-00	6-28	251-1547-00	7-3	251-1643-00	7-5	251-3051-00	Sect. 14 Index
251-1454-00	6-32	251-1548-00	7-3	251-1649-00	7-10	251-3052-00	15-2
251-1455-00	6-32	251-1549-00	6-31	251-1650-00	6-37	251-3053-00	14-2
251-1456-02	6-29	251-1550-00	6-31	251-1656-00	6-36	251-3053-01	14-2
251-1457-00	6-32	251-1552-00	6-38	251-1657-00	7-3	251-3054-00	8-3
251-1458-00	6-14	251-1553-00	6-24	251-1671-00	6-28	251-3055-00	14-3
251-1459-00	7-3	251-1554-00	6-24	251-1672-00	6-27	251-3056-00	15-2
251-1460-00	Sect. 6 Index	251-1555-00	6-37	251-1673-00	6-28	251-3057-00	15-2
251-1461-00	6-9	251-1556-00	6-37	251-1674-00	Sect. 7 Index	251-3059-00	14-2
251-1462-00	6-9	251-1558-00	7-6	251-1675-00	6-2	251-3060-00	15-2
251-1463-00	Sect. 6 Index	251-1559-00	7-2	251-1677-00	7-3	251-3061-00	12-5
251-1464-00	6-29	251-1560-00	6-24	251-1678-00	6-7	251-3065-00	15-4
251-1465-00	6-21	251-1561-00	7-5	251-1680-00	6-7	252-0006-00	5-4
251-1469-00	6-8	251-1563-00	6-8	251-1681-00	6-2	252-0008-00	5-4
251-1470-00	6-18	251-1565-00	6-24	251-1682-00	6-37	252-0010-00	Sect. 12 Index
251-1471-00	6-37	251-1566-00	6-9	251-1685-00	6-30	252-0011-00	5-2
251-1472-00	6-18	251-1567-00	6-25	251-1690-00	7-4	252-0021-00	5-3
251-1475-00	6-25	251-1568-00	6-15	251-1691-00	6-25	252-0022-00	Sect. 5 Index
251-1476-00	6-25	251-1569-00	6-9	251-1691-01	6-25	252-0024-00	5-4
251-1477-00	6-11	251-1570-00	Sect. 6 Index	251-1692-00	7-5	252-0026-00	Sect. 5 Index
251-1478-00	6-23	251-1571-00	7-3	251-1697-00	6-19	252-0027-00	5-3
251-1479-00	6-35	251-1572-00	6-9	251-1698-00	6-2	252-0028-00	5-2
251-1480-00	6-25	251-1573-01	6-24	251-1699-00	6-27	252-0029-00	4-6
251-1482-00	6-10	251-1574-00	6-27	251-1700-00	6-27	252-0030-00	5-2
251-1483-00	7-3	251-1575-00	6-26	251-1701-00	6-27	252-0031-00	Sect. 5 Index
251-1485-00	6-10	251-1576-00	6-28	251-1702-00	7-3	252-0039-00	5-6
251-1486-00	6-37	251-1577-00	6-27	251-1703-00	6-2	252-0041-00	1-38
251-1487-00	6-38	251-1578-00	6-9	251-1704-00	6-19	252-0045-00	12-8
251-1488-00	6-38	251-1580-00	6-31	251-1706-00	6-25	252-0047-00	5-4
251-1489-00	6-11	251-1581-00	6-28	251-1707-00	6-25	252-0052-00	5-2
251-1490-00	6-22	251-1582-00	6-9	251-1709-00	6-7	252-0060-00	Sect. 12 Index
251-1491-00	6-22	251-1584-00	6-28	251-1723-00	7-2	252-0062-00	5-2

MATERIALS CATALOG PART NUMBER INDEX (CONT)

THIS IS AN INDEX TO THIS CATALOG

PART NUMBER	PAGE NO.	PART NUMBER	PAGE NO.	PART NUMBER	PAGE NO.	PART NUMBER	PAGE NO.
252-0063-00	5-2	252-0203-03	Sect. 5 Index	252-0562-00	2-9	253-0052-00	4-4
252-0064-00	5-2	252-0203-04	5-2	252-0564-00	2-9	253-0054-00	4-2
252-0065-00	5-2	252-0203-05	5-3	252-0565-00	2-7	253-0055-00	4-2
252-0070-00	Sect. 12 Index	252-0204-00	5-2	252-0566-00	2-6	253-0056-00	4-3
252-0077-00	1-38 & 5-3	252-0210-00	1-38	252-0568-00	2-6	253-0059-00	4-3
252-0082-00	5-3	252-0212-00	1-38	252-0570-00	2-6	253-0060-00	4-2
252-0087-00	5-2	252-0213-00	1-35	252-0571-00	2-9	253-0062-00	4-3
252-0089-00	1-38 & 5-3	252-0214-00	1-35	252-0578-00	2-7	253-0063-00	4-2
252-0091-00	5-2	252-0215-00	5-3	252-0589-00	2-6	253-0064-00	4-3
252-0092-00	Sect. 5 Index	252-0217-00	5-2	252-0590-00	Sect. 2 Index	253-0065-00	4-2
252-0092-01	Sect. 5 Index	252-0217-01	Sect. 5 Index	252-0591-00	2-6	253-0066-00	4-3
252-0092-02	5-2	252-0217-02	Sect. 5 Index	252-0594-00	Sect. 2 Index	253-0068-00	2-8
252-0093-00	Sect. 12 Index	252-0217-03	5-2	252-0597-00	2-6	253-0070-00	4-3
252-0095-00	5-2	252-0224-00	5-2	252-0597-01	2-6	253-0071-00	4-3
252-0098-00	1-33	252-0229-00	5-2	252-0603-00	2-3 & 4-3	253-0072-00	4-3
252-0107-00	4-8	252-0229-01	5-2	252-0617-00	2-8	253-0074-00	4-5
252-0108-00	3-6 & 4-8	252-0229-02	5-2	252-0630-00	2-8	253-0075-00	4-4
252-0109-00	3-6	252-0229-03	5-2	252-0633-00	2-8	253-0076-00	4-2
252-0109-02	4-8	252-0229-04	5-2	252-0635-00	4-3	253-0077-00	4-2
252-0115-00	3-6	252-0229-05	5-2	252-0636-00	2-6	253-0078-00	4-3
252-0115-01	3-6 & 4-8	252-0235-00	5-2	252-0651-00	4-4	253-0079-00	4-2
252-0115-02	3-6 & 4-8	252-0235-01	Sect. 5 Index	252-0652-00	15-2	253-0080-00	2-8
252-0115-03	3-6 & 4-8	252-0236-00	5-2	252-0653-00	15-2	253-0081-00	2-8
252-0115-04	4-8	252-0237-00	5-6	252-0654-00	15-2	253-0082-00	2-8
252-0116-00	5-3	252-0238-00	5-6	252-0655-00	1-35	253-0083-00	4-4
252-0117-00	1-35	252-0240-00	5-2	252-0656-00	5-6	253-0084-00	4-2
252-0120-00	5-4	252-0247-00	5-2	252-0657-00	Sect. 2 Index	253-0086-00	4-2
252-0121-02	3-6	252-0248-00	5-2	252-0658-00	4-6	253-0087-00	4-2
252-0121-03	3-6	252-0249-00	5-2	252-0674-00	2-3	253-0088-00	4-2
252-0121-04	3-6	252-0250-00	5-2	252-0682-00	4-6	253-0090-00	4-2
252-0123-00	Sect. 5 Index	252-0251-00	5-3	252-0683-00	4-4	253-0091-00	4-2
252-0124-00	5-2	252-0252-00	5-3	252-0684-00	4-4	253-0092-00	2-8
252-0125-00	Sect. 5 Index	252-0258-00	5-3	252-0687-00	2-5	253-0093-00	4-5
252-0127-00	5-2	252-0259-00	5-3	252-0688-00	2-8	253-0095-00	4-4
252-0133-00	5-4	252-0259-01	5-3	252-0689-00	2-8	253-0096-00	2-8
252-0150-00	5-5	252-0259-02	5-3	252-0691-00	2-8	253-0097-00	4-2
252-0153-00	1-38	252-0259-03	5-3	252-0692-00	2-5	253-0101-00	4-4
252-0156-00	4-6	252-0259-04	5-3	252-0696-00	4-4	253-0102-00	4-2
252-0157-00	5-2	252-0260-00	Sect. 5 Index	252-0697-00	4-4	253-0103-00	4-2
252-0158-00	5-2	252-0261-00	1-35	252-0698-00	2-3	253-0104-00	4-2
252-0159-00	5-2	252-0262-00	5-2	252-0700-00	1-34	253-0107-00	4-2
252-0165-00	5-6	252-0263-00	5-2	252-0700-01	1-34	253-0114-00	4-2
252-0168-00	3-6 & 4-8	252-0264-00	5-2	252-0703-00	Sect. 2 Index	253-0115-00	4-2
252-0169-00	5-3	252-0264-01	5-2	252-0705-00	2-7	253-0116-00	4-3
252-0174-00	Sect. 4 Index	252-0264-02	5-2	252-0709-00	2-7	253-0117-00	4-3
252-0175-00	Sect. 5 Index	252-0264-03	5-2	252-0714-00	2-2	253-0118-00	4-2
252-0176-00	1-38	252-0268-00	5-2	252-0716-00	5-2	253-0119-00	4-2
252-0180-00	5-2	252-0269-00	5-6	252-0718-00	4-6	253-0120-00	4-3
252-0181-00	5-2	252-0270-00	5-6	252-0723-00	5-2	253-0123-00	2-8
252-0182-00	5-3	252-0271-00	Sect. 5 Index	252-0725-00	2-8	253-0124-00	2-8
252-0187-00	5-2	252-0272-00	5-3	252-0726-00	3-6	253-0125-00	4-2
252-0187-01	Sect. 5 Index	252-0273-00	5-2	252-0731-00	4-6	253-0126-00	4-3
252-0187-02	Sect. 5 Index	252-0274-00	5-6	253-0013-00	4-3	253-0127-00	2-8
252-0187-03	5-2	252-0276-00	4-6	253-0015-00	4-3	253-0128-00	4-5
252-0188-00	5-2	252-0504-00	2-8	253-0018-00	Sect. 4 Index	253-0130-00	4-3
252-0190-00	1-39	252-0506-00	2-7	253-0019-00	4-2	253-0131-00	4-2
252-0191-00	5-3	252-0509-00	2-9	253-0020-00	2-8	253-0132-00	4-4
252-0192-00	1-39	252-0511-00	2-8	253-0021-00	4-2	253-0135-00	4-3
252-0193-00	1-39	252-0512-00	2-8	253-0022-00	2-8	253-0136-00	4-2
252-0194-00	1-39	252-0514-00	2-8	253-0023-00	4-5	253-0137-00	4-3
252-0194-01	1-39	252-0516-00	2-8	253-0024-00	4-5	253-0138-00	4-2
252-0194-02	1-39	252-0517-00	2-8	253-0025-00	2-8	253-0140-00	4-2
252-0194-03	1-39	252-0518-00	2-8	253-0026-00	Sect. 2 Index	253-0142-00	4-2
252-0194-04	1-39	252-0523-00	2-8	253-0028-00	4-4	253-0143-00	4-2
252-0194-05	1-39	252-0524-00	2-8	253-0030-00	2-5	253-0144-00	4-2
252-0194-06	1-39	252-0529-00	2-8	253-0032-00	4-2	253-0145-00	4-2
252-0194-07	1-39	252-0530-00	2-8	253-0033-00	4-5	253-0148-00	4-5
252-0194-08	1-39	252-0532-00	2-8	253-0038-00	2-8	253-0149-00	4-3
252-0194-09	1-39	252-0537-00	2-8	253-0039-00	4-2	253-0149-01	4-3
252-0196-00	1-39	252-0545-00	2-8	253-0044-00	4-4	253-0151-00	4-2
252-0199-00	1-35	252-0548-00	2-8	253-0045-00	4-4	253-0152-00	4-3
252-0200-00	4-6	252-0551-00	2-8	253-0046-00	2-8	253-0153-00	4-3
252-0203-00	Sect. 5 Index	252-0555-00	2-7	253-0047-00	4-2	253-0154-00	4-3
252-0203-01	5-2	252-0559-00	2-6	253-0049-00	4-2	253-0155-00	4-5
252-0203-02	Sect. 5 Index	252-0560-00	2-6	253-0051-00	4-3	253-0157-00	4-2

MATERIALS CATALOG PART NUMBER INDEX (CONT)

THIS IS AN INDEX TO THIS CATALOG

PART NUMBER	PAGE NO.	PART NUMBER	PAGE NO.	PART NUMBER	PAGE NO.	PART NUMBER	PAGE NO.
253-0158-00	2-8	253-0259-00	4-3	254-0564-00	3-3	254-0605-00	Sect. 3 Index
253-0159-00	2-8	253-0261-00	Sect. 4 Index	254-0566-00	3-4	254-0606-00	Sect. 3 Index
253-0160-00	4-3	253-0262-00	4-5	254-0567-01	Sect. 3 Index	254-0607-00	3-2
253-0161-00	4-2	253-0263-00	Sect. 4 Index	254-0568-00	3-2	254-0608-00	Sect. 3 Index
253-0162-00	Sect. 4 Index	253-0264-00	4-5	254-0568-01	3-2	254-0609-00	Sect. 3 Index
253-0164-00	4-4	253-0265-00	2-8	254-0568-02	3-2	254-0611-00	Sect. 3 Index
253-0165-00	4-5	253-0265-01	2-8	254-0568-03	3-2	254-0611-02	Sect. 3 Index
253-0166-00	4-5	253-0266-00	4-5	254-0568-04	3-2	254-0613-00	Sect. 3 Index
253-0171-00	4-3	253-0268-00	4-3	254-0568-05	3-2	254-0613-01	Sect. 3 Index
253-0172-00	2-8	253-0269-00	4-3	254-0568-06	3-2	254-0614-00	Sect. 3 Index
253-0173-00	Sect. 4 Index	253-0270-00	4-4	254-0568-07	3-2	254-0615-03	Sect. 3 Index
253-0174-00	4-2	253-0272-00	4-4	254-0569-00	Sect. 3 Index	254-0618-00	3-3
253-0175-00	4-2	253-0273-00	4-4	254-0570-00	3-2	254-0618-01	3-3
253-0176-00	4-3	253-0274-00	4-2	254-0570-01	3-2	254-0618-04	3-3
253-0179-00	4-3	253-0276-00	4-6	254-0570-02	3-2	254-0618-05	3-3
253-0181-00	2-8	253-0277-00	4-4	254-0570-03	3-2	254-0618-06	3-3
253-0182-00	4-2	253-0279-00	4-2	254-0570-04	3-2	254-0618-07	3-3
253-0184-00	4-3	253-0280-00	4-3	254-0571-00	3-2	254-0618-08	Sect. 3 Index
253-0185-00	4-3	253-0281-00	4-2	254-0571-01	3-2	254-0618-09	3-3
253-0187-00	4-2	253-0282-00	4-5	254-0571-02	3-2	254-0618-10	3-3
253-0188-00	4-4	253-0283-00	4-2	254-0571-03	3-2	254-0618-11	3-3
253-0189-00	4-3	253-0284-00	4-2	254-0572-00	3-2	254-0618-12	3-3
253-0190-00	4-4	253-0285-00	2-8	254-0572-01	3-2	254-0618-13	3-3
253-0191-00	4-2	253-0288-00	4-5	254-0572-02	3-2	254-0621-01	Sect. 3 Index
253-0192-00	4-3	253-0289-00	4-5	254-0572-03	3-2	254-0623-00	Sect. 3 Index
253-0196-00	4-2	253-0290-00	4-5	254-0572-04	3-2	254-0623-01	3-3
253-0197-00	4-2	253-0291-00	4-2	254-0572-05	3-2	254-0623-03	Sect. 3 Index
253-0198-00	4-3	253-0292-00	4-2	254-0572-06	3-2	254-0623-04	3-3
253-0199-00	4-3	253-0293-00	2-5 & 4-3	254-0572-07	3-2	254-0624-00	Sect. 3 Index
253-0201-00	4-3	253-0294-00	4-5	254-0572-08	3-2	254-0624-01	Sect. 3 Index
253-0202-00	4-2	253-0295-00	4-5	254-0573-00	3-2	254-0625-00	Sect. 3 Index
253-0203-00	2-8	253-0296-00	4-5	254-0573-01	3-2	254-0627-00	3-2
253-0204-00	4-2	253-0297-00	2-5 & 4-2	254-0573-02	Sect. 3 Index	254-0627-01	3-2
253-0205-00	4-3	253-0298-00	2-4 & 4-2	254-0573-03	3-2	254-0628-00	3-2
253-0206-00	4-3	253-0299-00	4-2	254-0573-04	3-2	254-0628-01	3-2
253-0207-00	4-3	253-0300-00	4-5	254-0573-05	3-2	254-0629-00	3-2
253-0210-00	4-3	253-0301-00	4-5	254-0573-06	3-2	254-0630-00	Sect. 3 Index
253-0211-00	4-3	253-0301-01	4-5	254-0573-07	3-2	254-0634-00	3-3
253-0212-00	4-3	253-0302-00	4-5	254-0576-00	3-3	254-0635-00	3-2
253-0216-00	4-3	253-0303-00	4-3	254-0577-00	3-2	254-0636-00	Sect. 3 Index
253-0217-00	4-3	253-0304-00	2-4 & 4-2	254-0577-01	3-2	254-0637-00	Sect. 3 Index
253-0218-00	4-3	253-0308-00	2-5	254-0577-02	3-2	254-0638-00	3-2
253-0219-00	4-2	254-0504-00	2-2	254-0577-03	3-2	254-0639-00	3-2
253-0220-00	4-5	254-0505-00	2-2	254-0577-04	3-2	254-0640-00	3-2
253-0221-00	4-2	254-0507-00	2-2	254-0577-05	3-2	254-0640-01	3-2
253-0224-00	4-5	254-0509-00	2-6	254-0577-06	3-2	254-0641-00	Sect. 3 Index
253-0225-00	4-5	254-0510-00	2-6	254-0577-07	3-2	254-0642-00	Sect. 3 Index
253-0226-00	4-5	254-0512-00	2-6	254-0577-08	3-2	254-0642-01	Sect. 3 Index
253-0227-00	4-2	254-0514-00	2-6	254-0577-09	3-2	254-0643-00	3-3
253-0228-00	4-2	254-0515-00	2-6	254-0577-10	3-2	254-0644-00	3-4
253-0229-00	4-2	254-0519-00	2-3	254-0578-00	3-3	254-0644-01	3-4
253-0230-00	4-3	254-0527-00	2-3	254-0580-00	3-2	254-0646-00	2-4
253-0231-00	Sect. 2 Index	254-0530-00	2-2	254-0581-00	3-3	254-0647-00	2-6
253-0232-00	4-3	254-0531-00	2-6	254-0582-00	3-3	254-0648-00	3-3
253-0234-00	4-2	264-0534-00	2-6	254-0584-00	3-2	254-0649-00	Sect. 3 Index
253-0236-00	4-3	254-0536-00	2-6	254-0588-00	3-2	254-0650-00	3-3
253-0237-00	4-3	254-0537-00	2-6	254-0590-00	3-2	254-0651-00	3-3
253-0238-00	4-3	254-0539-00	2-3	254-0592-00	3-3	254-0652-00	3-3
253-0239-00	4-3	254-0541-00	3-3	254-0593-00	3-2	254-0653-00	2-7
253-0240-00	4-2	254-0541-05	Sect. 3 Index	254-0593-02	3-2	254-0654-00	2-4
253-0241-00	4-3	254-0541-06	3-3	254-0593-03	3-2	254-0655-00	3-3
253-0243-00	4-2	254-0541-08	3-3	254-0594-00	3-3	254-0656-00	3-2
253-0244-00	4-5	254-0541-09	3-3	254-0597-00	3-3	254-0657-00	3-3
253-0245-00	4-5	254-0541-10	3-3	254-0598-00	3-3	254-0658-00	3-2
253-0246-00	4-3	254-0541-11	3-2	254-0598-01	3-3	254-0659-00	3-3
253-0247-00	4-5	254-0546-00	3-4	254-0599-00	3-3	254-0659-01	3-3
253-0248-00	4-3	254-0547-00	2-6	254-0600-00	3-4	254-0660-00	3-2
253-0249-00	Sect. 4 Index	254-0548-00	3-3	254-0601-00	3-4	254-0661-00	3-2
253-0251-00	4-5	254-0551-00	3-2	254-0602-00	3-2	254-0662-00	Sect. 3 Index
253-0252-00	4-2	254-0551-04	3-2	254-0602-01	3-2	254-0663-00	3-2
253-0253-00	4-3	254-0551-05	3-2	254-0602-02	3-2	254-0664-00	3-2
253-0254-00	4-2	254-0556-00	3-4	254-0603-00	3-3	254-0665-00	3-3
253-0255-00	4-2	254-0559-00	3-2	254-0603-01	3-3	254-0666-00	3-3
253-0257-00	4-5	254-0563-01	Sect. 3 Index	254-0604-00	3-3	254-0667-00	3-4
253-0258-00	2-8	254-0563-03	Sect. 3 Index	254-0604-01	3-3	254-0907-00	2-5

MATERIALS CATALOG PART NUMBER INDEX (CONT)

THIS IS AN INDEX TO THIS CATALOG

PART NUMBER	PAGE NO.	PART NUMBER	PAGE NO.	PART NUMBER	PAGE NO.	PART NUMBER	PAGE NO.
254-0908-00	2-5	255-0087-00	2-3	255-0190-00	1-5	255-0305-00	2-5
254-0911-00	2-5	255-0090-00	1-5	255-0191-00	2-6	255-0307-00	2-2
254-0914-00	2-2	255-0093-00	2-4	255-0196-00	2-2	255-0308-00	1-18
254-0915-00	2-2	255-0095-00	1-8	255-0197-00	1-5	255-0309-00	2-7
254-0916-00	2-2	255-0099-00	1-6	255-0198-00	2-2	255-0310-00	2-6
254-0917-00	2-2	255-0100-00	1-29	255-0199-00	2-4	255-0311-00	2-4
254-0918-00	2-2	255-0104-00	2-2	255-0200-00	2-7	255-0312-00	1-8
254-0919-00	Sect. 2 Index	255-0105-00	1-29	255-0201-00	Sect. 2 Index	255-0313-00	1-8
254-0922-00	1-9	255-0108-00	2-2	255-0202-00	2-4	255-0317-01	1-20
254-0923-00	1-9	255-0109-00	1-5	255-0203-00	1-24	255-0318-00	1-6
254-0925-00	1-16	255-0110-00	1-21	255-0204-00	2-4	255-0319-00	2-5
254-0927-00	2-2	255-0112-00	1-22	255-0205-00	2-4	255-0320-00	1-5
254-0934-00	2-5	255-0113-00	1-8	255-0206-00	2-4	255-0325-00	2-5
254-0934-01	2-4	255-0114-00	1-38	255-0207-00	1-5	255-0326-00	2-4
254-0935-00	2-5	255-0115-00	Sect. 1 Index	255-0208-00	1-36	255-0327-00	1-20
254-0937-00	1-39	255-0116-00	2-2	255-0212-00	1-36	255-0328-00	1-24
254-0938-00	1-9	255-0117-00	1-15	255-0214-00	1-5	255-0329-00	Sect. 1 Index
254-0939-00	1-22	255-0118-00	2-4	255-0215-00	1-21	255-0330-00	1-30
254-0940-00	1-16	255-0119-00	2-4	255-0217-00	1-5	255-0332-00	1-17
254-0944-00	2-5	255-0120-00	2-4	255-0219-00	1-8	255-0334-00	2-9
254-0946-00	2-4	255-0121-00	2-4	255-0220-00	1-8	255-0335-00	1-27
254-0948-00	2-2	255-0122-00	2-4	255-0221-00	Sect. 1 Index	255-0336-00	Sect. 1 Index
254-0949-00	2-2	255-0123-00	1-32	255-0223-00	1-26	255-0337-00	1-31
254-0950-00	2-2	255-0124-00	2-3	255-0224-00	2-6	255-0339-00	1-19
254-0951-00	2-2	255-0125-00	2-5	255-0225-00	Sect. 1 Index	255-0344-00	3-4
254-0955-00	2-6	255-0126-00	2-5	255-0227-00	1-5	255-0345-00	2-2
254-0956-00	2-4	255-0127-00	2-2	255-0228-00	1-5	255-0355-00	1-36
254-0959-00	Sect. 2 Index	255-0130-00	1-36	255-0229-00	1-5	255-0356-00	1-36
254-0960-00	2-7	255-0132-00	2-2	255-0230-00	1-5	255-0359-00	1-14
254-0960-03	2-7	255-0133-00	2-4	255-0231-00	1-5	255-0364-00	1-20
254-0965-00	1-28	255-0134-00	1-8	255-0232-00	1-5	255-0365-00	1-16
254-0966-00	1-22	255-0139-00	2-2	255-0233-00	1-5	255-0366-00	2-4
254-0972-00	2-2	255-0140-00	1-10	255-0235-00	1-18	255-0367-00	2-4
254-0978-00	2-2	255-0141-00	2-5	255-0237-00	2-6	255-0368-00	1-17
254-0979-00	1-19	255-0141-01	2-5	255-0238-00	Sect. 2 Index	255-0370-00	1-31
254-0984-00	1-28	255-0143-00	2-5	255-0239-00	1-28	255-0370-01	1-31
254-0985-00	1-26	255-0143-01	2-5	255-0240-00	1-5	255-0370-02	1-31
254-0987-00	1-16	255-0144-00	2-4	255-0244-00	1-9	255-0371-00	2-7
254-0990-00	1-26	255-0145-00	2-2	255-0245-00	1-26	255-0372-00	1-38
254-0995-00	1-16	255-0146-00	2-7	255-0249-00	2-9	255-0374-00	1-23
254-0997-00	Sect. 1 Index	255-0147-00	2-4	255-0254-00	2-4	255-0376-00	1-8
254-0998-00	1-5	255-0148-00	1-13	255-0255-00	1-36	255-0378-00	1-17
254-1000-00	1-34	255-0149-00	Sect. 1 Index	255-0257-00	2-4	255-0382-00	1-7
255-0001-00	1-29	255-0150-00	Sect. 2 Index	255-0258-00	2-4	255-0383-00	1-33
255-0007-00	1-16	255-0151-00	2-4	255-0259-00	2-4	255-0384-00	Sect. 1 Index
255-0009-00	1-8	255-0152-00	2-4	255-0262-00	1-32	255-0385-00	1-6
255-0010-00	1-5	255-0153-00	2-4	255-0263-00	2-6	255-0386-00	1-13
255-0011-00	2-4	255-0155-00	2-4	255-0264-00	1-20	255-0387-00	1-16
255-0014-00	1-5	255-0156-00	1-20	255-0267-00	1-20	255-0387-01	1-16
255-0015-00	1-8	255-0159-00	2-2	255-0268-00	2-4	255-0387-02	1-16
255-0017-00	1-36	255-0160-00	1-5	255-0270-00	1-20	255-0388-00	2-4
255-0018-00	1-23	255-0161-00	1-8	255-0271-00	1-7	255-0394-00	1-39
255-0020-00	2-3	255-0163-00	2-2	255-0272-00	1-26	255-0395-00	Sect. 1 Index
255-0026-00	1-15	255-0164-00	2-2	255-0273-00	1-26	255-0396-00	Sect. 1 Index
255-0027-00	1-39	255-0166-00	2-5	255-0274-00	1-26	255-0397-00	2-6
255-0028-00	2-2	255-0167-00	Sect. 2 Index	255-0275-00	2-5	255-0398-00	Sect. 1 Index
255-0029-00	2-2	255-0168-00	Sect. 2 Index	255-0275-01	2-5	255-0401-00	Sect. 2 Index
255-0031-00	2-4	255-0171-00	2-2	255-0276-00	2-2	255-0403-00	1-37
255-0032-00	2-3	255-0172-00	1-16	255-0278-00	2-2	255-0405-00	1-10
255-0033-00	1-16	255-0173-00	1-5	255-0280-00	2-4	255-0406-00	1-38
255-0041-00	1-26	255-0173-01	1-5	255-0282-00	1-13	255-0408-00	1-34
255-0045-00	1-26	255-0173-02	1-5	255-0284-00	1-36	255-0410-00	1-33
255-0048-00	2-3	255-0173-03	1-5	255-0285-00	1-5	255-0411-00	2-7
255-0050-00	1-16	255-0174-00	1-6	255-0286-00	1-20	255-0412-00	2-9
255-0058-00	2-6	255-0177-00	2-7	255-0291-00	2-6	255-0413-00	2-5
255-0061-00	1-6	255-0178-00	2-4	255-0292-00	1-20	255-0416-00	2-6
255-0062-00	2-2	255-0180-00	1-5	255-0294-00	1-17	255-0417-00	2-7
255-0064-00	1-27	255-0181-00	1-36	255-0295-00	2-7 & 3-4	255-0417-01	2-7
255-0071-00	1-23	255-0182-00	2-4	255-0298-00	1-20	255-0417-02	Sect. 2 Index
255-0073-00	2-4	255-0185-00	2-5	255-0299-00	1-37	255-0418-00	2-6
255-0075-00	2-4	255-0185-01	2-5	255-0300-00	2-4	255-0419-00	2-4
255-0078-00	2-3	255-0186-00	2-5	255-0301-00	2-4	255-0421-00	2-2
255-0079-00	2-3	255-0187-00	2-5	255-0302-00	1-8	255-0422-00	Sect. 2 Index
255-0081-00	1-8	255-0188-00	1-22 & 1-39	255-0303-00	1-17	255-0423-00	1-18
255-0082-00	1-20	255-0189-00	1-5	255-0304-00	1-23	255-0424-00	2-4

MATERIALS CATALOG PART NUMBER INDEX (CONT)

THIS IS AN INDEX TO THIS CATALOG

PART NUMBER	PAGE NO.	PART NUMBER	PAGE NO.	PART NUMBER	PAGE NO.	PART NUMBER	PAGE NO.
255-0425-00	2-4	255-0532-00	1-18	255-0624-00	1-25	255-0706-00	3-5
255-0427-00	2-7	255-0533-00	2-5 & 3-4	255-0625-00	1-15	255-0707-00	3-5
255-0430-00	1-39	255-0533-01	2-5 & 3-4	255-0628-00	3-5	255-0708-00	3-5
255-0431-00	2-5	255-0533-02	2-5 & 3-4	255-0629-00	Sect. 1 Index	255-0710-00	1-18
255-0432-00	2-4	255-0533-03	2-5 & 3-4	255-0630-00	2-10	255-0711-00	Sect. 2 Index
255-0433-00	2-4	255-0535-00	2-5	255-0630-01	2-10	255-0712-00	3-5
255-0434-00	1-39	255-0536-00	1-38	255-0630-02	2-10	255-0713-00	2-9
255-0435-00	1-36	255-0537-00	2-2	255-0630-03	2-10	255-0714-00	2-10
255-0436-00	1-39	255-0538-00	1-25	255-0631-00	2-10	255-0714-01	2-10
255-0438-00	1-19	255-0539-00	1-17	255-0631-01	2-10	255-0714-02	2-10
255-0439-00	2-3	255-0540-01	1-20	255-0631-02	2-10	255-0714-03	2-10
255-0440-00	2-5	255-0541-01	3-5	255-0631-03	2-10	255-0715-00	1-33
255-0442-00	2-5	255-0542-00	1-15	255-0632-00	2-5	255-0716-00	1-33
255-0443-00	1-19	255-0544-00	1-33	255-0634-00	1-15	255-0717-00	2-10
255-0444-00	1-19	255-0545-00	Sect. 2 Index	255-0640-00	3-4	255-0717-01	2-10
255-0445-00	1-19	255-0548-00	1-15	255-0642-00	2-5	255-0717-02	2-10
255-0446-00	1-6	255-0549-00	Sect. 1 Index	255-0643-00	2-7	255-0717-03	2-10
255-0447-00	1-7	255-0550-00	1-9	255-0644-00	1-8	255-0718-00	Sect. 2 Index
255-0448-00	1-39	255-0551-00	2-6	255-0644-01	1-8	255-0719-00	1-30
255-0449-00	2-2	255-0552-00	Sect. 2 Index	255-0644-02	1-8	255-0720-00	1-38
255-0450-00	2-9	255-0553-00	1-39	255-0644-03	1-8	255-0721-00	2-7
255-0452-00	1-39	255-0555-00	2-4	255-0644-04	1-8	255-0725-00	1-39
255-0454-00	2-7	255-0558-00	2-4	255-0644-05	1-8	255-0731-00	1-38
255-0455-00	2-4	255-0559-00	1-39	255-0644-06	1-8	255-0733-00	2-10
255-0456-00	2-4	255-0560-00	1-39	255-0645-00	2-7	255-0734-00	2-2
255-0457-00	2-7	255-0561-00	1-39	255-0646-00	1-21	255-0735-00	1-20
255-0459-00	2-6	255-0562-00	1-39	255-0647-00	4-4	255-0736-00	1-20
255-0460-00	1-36	255-0563-00	1-39	255-0648-00	2-9	255-0737-00	1-20
255-0461-01	Sect. 1 Index	255-0564-00	1-39	255-0649-00	3-5	255-0738-00	1-20
255-0462-00	1-39	255-0565-01	1-20	255-0650-00	3-5	255-0739-00	1-20
255-0463-00	2-2	255-0565-02	1-20	255-0651-00	1-20	255-0740-00	1-20
255-0466-00	1-12	255-0565-03	1-20	255-0652-00	1-20	255-0741-00	1-20
255-0469-00	1-5	255-0565-04	1-20	255-0653-00	2-5	255-0742-00	1-20
255-0470-00	1-18	255-0565-05	1-20	255-0654-00	1-18	255-0743-00	1-20
255-0470-01	1-18	255-0565-06	1-20	255-0655-00	1-31	255-0744-00	1-18
255-0470-02	1-18	255-0566-00	1-36	255-0656-00	2-10	255-0745-00	1-17
255-0471-00	1-16	255-0567-00	2-3	255-0656-01	2-10	255-0753-00	2-2
255-0472-00	1-34	255-0569-00	4-3	255-0656-02	2-10	255-0755-00	1-9
255-0473-00	Sect. 1 Index	255-0570-00	1-39	255-0656-03	2-10	255-0756-00	1-24
255-0475-00	2-4	255-0571-00	1-34	255-0659-00	2-4	255-0756-01	1-24
255-0476-00	1-39	255-0572-00	1-34	255-0660-00	2-4	255-0756-02	1-24
255-0479-00	1-38	255-0573-00	2-7	255-0661-00	1-34	255-0756-03	1-24
255-0481-00	2-4	255-0574-00	1-9	255-0663-00	2-2	255-0757-00	1-20
255-0482-00	1-38	255-0574-01	1-20	255-0664-00	2-7	255-0757-01	1-20
255-0483-00	1-7	255-0575-00	2-7 & 3-4	255-0665-00	Sect. 2 Index	255-0757-02	1-20
255-0486-00	2-6	255-0576-00	4-4	255-0668-00	3-5	255-0757-03	1-20
255-0488-00	1-19	255-0577-00	Sect. 2 Index	255-0669-00	3-5	255-0759-00	1-8
255-0488-01	1-19	255-0578-00	1-39	255-0670-00	2-6	255-0758-00	2-3
255-0488-02	1-19	255-0581-00	2-9	255-0671-00	3-5	255-0760-00	2-7
255-0488-03	1-19	255-0582-00	Sect. 1 Index	255-0672-00	3-5	255-0761-00	2-2
255-0488-04	1-19	255-0586-00	1-38	255-0673-00	3-5	255-0762-00	1-38
255-0488-05	1-19	255-0587-00	2-5	255-0674-00	1-27	255-0763-00	2-2
255-0502-00	1-27	255-0588-00	3-5	255-0676-00	Sect. 2 Index	255-0764-00	Sect. 1 Index
255-0503-00	2-5	255-0608-00	1-39	255-0679-00	2-7	255-0765-00	Sect. 1 Index
255-0504-00	1-18	255-0609-00	Sect. 3 Index	255-0680-00	1-39	255-0766-00	1-16
255-0505-00	1-23	255-0611-00	Sect. 3 Index	255-0682-00	1-8	255-0767-00	1-9
255-0506-00	2-6	255-0612-00	1-18	255-0683-00	1-8	255-0770-00	2-2
255-0507-00	Sect. 1 Index	255-0612-01	1-18	255-0684-00	Sect. 1 Index	255-0771-00	1-10
255-0508-00	1-22	255-0612-02	1-18	255-0686-00	1-38	255-0772-00	2-7
255-0510-00	1-10	255-0612-03	1-18	255-0687-00	3-5	255-0773-00	1-18
255-0511-00	1-39	255-0612-04	1-18	255-0688-00	1-19	255-0774-00	1-39
255-0512-00	Sect. 1 Index	255-0613-00	1-39	255-0689-00	2-9	255-0775-00	2-7
255-0513-00	1-39	255-0614-00	1-34	255-0691-00	2-5	255-0776-00	1-34
255-0514-00	2-6	255-0615-00	1-24	255-0692-00	1-39	255-0778-00	2-9
255-0515-00	1-33	255-0616-00	1-33	255-0693-00	1-8	255-0779-00	1-19
255-0516-00	3-4	255-0617-00	1-18	255-0695-00	1-25	255-0780-00	2-5
255-0516-01	3-4	255-0617-01	1-18	255-0696-00	1-18	255-0782-00	1-11
255-0516-02	3-4	255-0617-02	1-18	255-0697-00	3-5	255-0783-00	1-20
255-0517-00	1-39	255-0617-03	1-18	255-0699-00	3-5	255-0784-00	1-33
255-0520-00	1-34	255-0617-04	1-18	255-0700-00	1-18	255-0785-00	1-38
255-0520-01	Sect. 1 Index	255-0618-00	2-5	255-0701-00	1-18	255-0786-00	2-2
255-0521-00	Sect. 2 Index	255-0619-00	2-9	255-0702-00	2-5	255-0787-00	2-2
255-0523-00	1-33	255-0620-00	3-5	255-0703-00	2-3	255-0791-00	1-28
255-0527-01	1-20	255-0621-01	1-31	255-0704-00	2-2	255-0803-00	2-6
255-0528-00	2-2	255-0622-00	Sect. 2 Index	255-0705-00	Sect. 2 Index	255-0804-00	1-18

MATERIALS CATALOG PART NUMBER INDEX (CONT)

THIS IS AN INDEX TO THIS CATALOG

PART NUMBER	PAGE NO.	PART NUMBER	PAGE NO.	PART NUMBER	PAGE NO.	PART NUMBER	PAGE NO.
255-0805-00	2-7	256-0664-00	4-6 & 12-8	257-0108-00	12-6	258-0382-01	9-2
255-0806-00	2-9	256-0665-00	4-6 & 12-8	257-0109-00	12-6	258-0382-02	9-3
255-0807-00	2-8	256-0666-00	5-6	257-0110-00	12-6	258-0383-00	9-2
255-0808-00	2-7	256-0667-00	4-8	257-0111-00	12-6	258-0383-01	9-2
255-0809-00	1-39	256-0673-00	5-4	257-0112-00	12-6	258-0383-02	9-3
255-0810-00	1-32	256-0676-00	Sect. 5 Index	257-0113-00	12-6	258-0383-03	9-2
255-0812-00	1-9	256-0677-00	Sect. 5 Index	257-0115-00	12-6	258-0384-00	9-2
255-0813-00	1-38	256-0678-00	4-8	257-0116-00	12-6	258-0384-01	9-2
255-0814-00	1-20	256-0679-00	4-8	257-0117-00	12-6	258-0386-00	11-2
255-0815-00	1-39	256-0680-00	4-8	257-0118-00	12-6	258-0387-00	8-5
255-0817-00	1-39	256-0681-00	4-8	258-0301-00	8-3	258-0389-00	8-5
255-0818-00	1-39	256-0683-00	Sect. 4 Index	258-0303-00	8-3	258-0390-00	Sect. 10 Index
255-0819-00	1-39	256-0684-00	5-6	258-0304-00	8-3	258-0391-00	11-2
255-0820-00	1-39	256-0686-00	4-8	258-0305-00	8-5	258-0392-00	Sect. 12 Index
255-0821-00	1-9	256-0688-00	4-6	258-0306-00	8-3	258-0392-01	Sect. 12 Index
256-0509-00	5-7	256-0689-00	5-6	258-0307-00	8-2	258-0395-01	Sect. 12 Index
256-0510-00	4-8	256-0690-00	5-6	258-0307-01	8-4	258-0395-03	Sect. 12 Index
256-0513-00	4-8	256-0691-00	5-6	258-0307-02	8-4	258-0395-04	12-5
256-0515-00	4-8	256-0693-00	4-6	258-0307-03	8-4	258-0396-00	Sect. 9 Index
256-0517-00	4-8	256-0694-00	4-6	258-0307-04	8-4	258-0396-01	9-3
256-0520-00	4-8	256-0696-00	4-6	258-0307-05	8-4	258-0397-00	Sect. 12 Index
256-0523-00	4-8	256-0697-00	4-6	258-0307-06	8-4	258-0398-00	8-3
256-0529-00	Sect. 4 Index	256-0698-00	4-6	258-0307-07	8-4	258-0399-00	Sect. 9 Index
256-0530-00	4-8	256-0700-00	4-8	258-0308-00	Sect. 12 Index	258-0399-01	Sect. 9 Index
256-0531-00	4-8	256-0701-00	4-6	258-0309-00	8-5	258-0401-00	Sect. 12 Index
256-0532-00	4-8	256-0702-00	4-6	258-0317-00	8-5	258-0401-02	12-5
256-0533-00	2-8	257-0001-00	12-5	258-0318-00	8-2	258-0402-00	10-2
256-0534-00	5-7	257-0011-00	12-5	258-0319-00	12-2	258-0403-00	9-2
256-0549-00	4-8	257-0012-00	12-5	258-0321-00	8-5	258-0405-00	10-2
256-0551-00	4-8	257-0017-00	12-5	258-0322-00	8-2	258-0405-02	10-2
256-0554-00	4-8	257-0019-00	12-5	258-0325-00	9-3	258-0406-00	Sect. 8 Index
256-0555-00	Sect. 4 Index	257-0020-00	12-6	258-0329-00	11-2	258-0407-00	8-3
256-0558-00	1-38	257-0025-00	12-6	258-0332-00	12-4	258-0408-00	8-4
256-0559-00	4-8	257-0026-00	12-6	258-0337-00	8-2	258-0409-00	8-3
256-0562-00	5-6	257-0027-00	12-6	258-0337-01	Sect. 8 Index	258-0410-00	12-5
256-0564-00	Sect. 4 Index	257-0029-00	12-6	258-0337-02	Sect. 8 Index	258-0410-01	Sect. 12 Index
256-0565-00	Sect. 4 Index	257-0030-00	12-6	258-0337-03	8-4	258-0412-00	8-5
256-0569-00	4-8	257-0032-00	12-5	258-0337-04	8-4	258-0413-00	8-5
256-0570-00	4-7	257-0035-00	12-6	258-0340-00	11-2	258-0414-00	9-2
256-0571-00	4-8	257-0039-00	12-6	258-0342-00	8-2	258-0414-01	9-2
256-0579-00	5-6	257-0040-00	12-6	258-0344-00	8-3	258-0415-00	10-2
256-0584-00	4-8	257-0043-00	12-6	258-0345-00	12-5	258-0416-00	9-2
256-0591-00	4-8	257-0045-00	12-5	258-0347-00	Sect. 10 Index	258-0416-01	9-3
256-0592-00	Sect. 4 Index	257-0049-00	12-6	258-0350-00	Sect. 8 Index	258-0419-00	Sect. 12 Index
256-0593-00	4-8	257-0057-00	12-6	258-0351-00	Sect. 8 Index	258-0420-00	9-2
256-0597-00	5-6	257-0059-00	12-6	258-0352-00	9-2	258-0421-00	Sect. 9 Index
256-0598-00	5-6	257-0060-00	12-6	258-0354-00	12-2	258-0421-01	9-3
256-0604-00	4-8	257-0060-01	12-6	258-0355-00	12-2	258-0421-02	Sect. 9 Index
256-0605-00	4-8	257-0064-00	12-6	258-0355-01	12-2	258-0422-00	12-3
256-0606-00	4-8	257-0066-00	12-6	258-0356-00	8-2	258-0423-00	9-2
256-0609-00	5-6	257-0068-00	12-6	258-0357-00	12-2	258-0424-00	10-2
256-0611-00	4-8	257-0077-00	5-6 & 12-6	258-0358-00	8-2	258-0425-00	11-2
256-0612-00	Sect. 4 Index	257-0080-00	12-6	258-0359-00	8-2	258-0426-00	8-5
256-0613-00	4-8	257-0081-00	12-6	258-0360-00	8-2	258-0428-00	8-3
256-0614-00	4-8	257-0082-00	12-6	258-0364-00	12-4	258-0430-00	8-2
256-0615-00	5-6	257-0083-00	12-6	258-0365-00	8-2	258-0431-00	8-5
256-0617-00	4-8	257-0084-00	12-6	258-0366-00	8-2	258-0432-00	8-2
256-0618-00	4-8	257-0085-00	12-6	258-0368-00	8-2	258-0433-00	Sect. 9 Index
256-0619-00	5-6	257-0086-00	12-6	258-0370-00	12-4	258-0434-00	11-2
256-0620-00	4-8	257-0087-00	12-6	258-0372-00	Sect. 12 Index	258-0435-00	11-2
256-0630-00	4-8	257-0088-00	12-6	258-0373-00	12-5	258-0436-00	9-2
256-0631-00	Sect. 4 Index	257-0089-00	12-6	258-0374-00	Sect. 9 Index	258-0437-00	8-5
256-0632-00	Sect. 5 Index	257-0090-00	12-6	258-0374-01	Sect. 9 Index	258-0438-00	11-2
256-0634-00	4-8	257-0091-00	12-6	258-0374-02	9-2	258-0439-00	11-2
256-0640-00	5-6 & 4-6	257-0092-00	12-6	258-0374-03	9-3	258-0441-00	Sect. 12 Index
256-0646-00	Sect. 5 Index	257-0093-00	12-6	258-0376-00	8-3	258-0442-00	9-2
256-0649-00	5-6	257-0095-00	12-6	258-0377-00	8-2	258-0443-00	8-2
256-0651-00	5-6	257-0096-00	12-6	258-0378-01	9-3	258-0445-00	8-4
256-0652-00	5-6	257-0097-00	12-6	258-0378-02	9-2	258-0446-00	12-4
256-0653-00	5-6	257-0099-00	12-6	258-0379-00	8-3	258-0448-00	11-2
256-0654-00	5-6	257-0100-00	12-6	258-0380-00	8-5	258-0449-00	8-3
256-0655-00	5-6	257-0101-00	12-6	258-0381-00	9-2	258-0450-00	8-3
256-0656-00	5-6	257-0102-00	12-6	258-0381-01	9-2	258-0452-00	10-2
256-0659-00	5-6	257-0104-00	12-6	258-0381-02	Sect. 9 Index	258-0453-00	10-2
256-0660-00	5-6	257-0106-00	12-6	258-0382-00	9-2	258-0455-00	8-2

MATERIALS CATALOG PART NUMBER INDEX (CONT)

THIS IS AN INDEX TO THIS CATALOG

PART NUMBER	PAGE NO.	PART NUMBER	PAGE NO.
258-0462-00	Sect. 10 Index	333-2641-00	12-7
258-0463-00	9-2	333-2642-00	12-7
258-0463-01	9-2	333-2643-00	12-7
258-0464-00	9-3	333-2647-00	12-7
258-0466-00	8-3	333-2647-01	12-7
258-0468-00	9-3	333-2651-00	12-7
258-0469-00	14-3	333-2652-00	12-7
258-0469-01	14-3	333-2652-01	12-7
258-0469-02	14-3	333-2653-00	12-7
258-0470-00	10-2	333-2654-00	12-7
258-0471-00	9-2	333-2655-00	12-7
258-0472-00	Sect. 11 Index	333-2656-00	12-7
258-0481-00	14-3	333-2657-01	12-7
258-0482-00	8-2	333-2660-00	12-7
258-0484-00	Sect. 9 Index	333-2661-00	12-7
258-0485-00	9-2	333-2671-00	12-7
258-0485-01	Sect. 9 Index	333-2679-00	12-7
258-0485-02	9-2	333-2680-00	12-7
258-0485-03	9-2	333-2683-00	12-7
258-0486-00	Sect. 8 Index	333-2684-00	12-7
258-0487-00	8-2	333-2688-01	12-7
258-0488-00	11-2	333-2698-00	12-7
258-0489-00	8-5	333-2702-00	12-7
258-0490-00	11-2	333-2703-00	12-7
258-0491-00	11-2	333-2704-01	12-7
258-0492-00	Sect. 9 Index	333-2704-02	12-7
258-0493-00	11-2	333-2704-03	12-7
258-0494-00	Sect. 12 Index	333-2709-00	12-7
258-0496-00	12-5	333-2710-00	12-7
258-0497-00	12-5	333-2711-00	12-7
258-0499-00	8-2	333-2725-00	12-7
258-0500-00	8-3	333-2731-03	12-7
258-0501-00	Sect. 12 Index	333-2732-03	12-7
258-0504-00	10-2	333-2736-00	12-7
258-0505-00	8-5	333-2737-00	12-7
258-0506-00	12-5	333-2744-00	12-7
258-0507-00	9-2	333-2746-00	12-7
258-0508-00	12-5	333-2749-00	12-7
258-0509-00	8-4	333-2750-00	12-7
258-0510-00	9-3	333-2766-01	12-7
258-0511-00	8-5	333-2767-01	12-7
258-0512-00	12-5	333-2775-01	12-7
258-0513-00	11-2	333-2780-00	12-7
258-0518-00	11-2	333-2781-00	12-7
258-0519-00	8-4	333-2787-00	12-7
258-0520-00	8-4	333-2791-00	12-7
258-0521-00	8-5	333-2794-00	12-7
258-0522-00	12-5	333-2795-00	12-7
258-0523-00	8-5	333-2799-00	12-7
258-0525-00	9-3	333-2801-00	12-7
258-0526-00	12-5	333-2825-00	12-7
258-0527-00	Sect. 14 Index	333-2870-00	12-7
258-0528-00	9-2	333-2882-00	12-7
258-0529-00	9-3	333-2883-00	12-7
258-0532-00	12-5	333-2890-00	12-7
258-0533-00	11-2	333-2893-00	12-7
258-0534-00	12-5	333-2894-00	12-7
307-0210-00	Sect. 3 Index	342-0082-00	3-6
307-0211-02	3-6	342-0449-00	3-6
333-2454-02	12-7	342-0461-00	3-6
333-2510-00	12-7	342-0582-00	3-6
333-2532-00	12-7	342-0582-01	3-6
333-2559-00	12-7	348-0524-00	4-3
333-2560-00	12-7	439-0313-00	5-6
333-2566-00	12-7	439-0386-00	5-3
333-2567-00	12-7	439-0400-00	5-6
333-2575-00	12-7		
333-2599-00	12-7		
333-2599-01	12-7		
333-2607-00	12-7		
333-2608-00	12-7		
333-2609-00	12-7		
333-2619-00	12-7		
333-2631-00	12-7		
333-2631-01	12-7		

EVALUATION ENGINEER LIST

COMPONENT	COMPONENT ENGINEER	EXT.
ABSORBERS, RF	Phil Lee	2474
ACTUATOR ASSEMBLIES, PUSHBUTTON	Jim Deer	2484
ADAPTERS, ELECTRICAL, GR CONNECTORS, PROBES	Phil Lee	2474
ADHESIVES	Katherine Dennett	2314
ANGLES	Katherine Dennett	2314
ALUMINUM	Bella Geotina	2315
ATTENUATORS	Phil Lee	2474
BAFFLES, AIR	John Thomas	2466
BANDS, MARKING	Bella Geotina	2315
BARS (METAL)	Bella Geotina	2315
BATTERIES	Byron Witt	2479
BEARINGS	John Thomas	2466
BELTS (PULLIES)	John Thomas	2466
BEZELS (ACCESSORIES)	Dennis Johnson	2471
BLADDERS	John Thomas	2466
BLADES, SHUTTER	Katherine Dennett	2314
BLOCKS	Byron Witt	2479
BOARDS, TERMINAL	Phil Lee	2474
BODY (CONNECTORS)	Joe Reshey	2313
BOLTS	Kelly Cushing	2461
BOXES	Byron Witt	2479
BRACES	Katherine Dennett	2314
BRACKETS	John Thomas	2466
BRASS	Bella Geotina	2315
BRONZE	Bella Geotina	2315
BRUSHES, MOTOR	John Thomas	2466
BUMPERS	Kelly Cushing	2461
BUSHINGS	John Thomas	2466
BUTTONS, PLUG	Kelly Cushing	2461
CABINET PARTS	Katherine Dennett	2314
CABLE ASSEMBLIES (BULK & WIRE)	Elizabeth Doolittle	2309
CABLES, GPIB	Phil Lee	2474
CABLES, RF	Phil Lee	2474
CABLES, ELECTRICAL ADAPTERS	Phil Lee	2474
CABLES, POWER	Dennis Johnson	2471
CABLES, NIPPLE	Jim Deer	2484
CAMS	John Thomas	2466
CANS	Byron Witt	2479
CAPS	Kelly Cushing	2461
CAPACITORS Aluminum, Tantalum Ceramic Film, Electrolytic Variable, Mica Tek-Made	Harry Tanielian Ray Powell Don Anderson Louis Mahn Jim Manuel	2545 2550 2545 2549 4442

COMPONENT	COMPONENT ENGINEER	EXT.
CASES	Byron Witt	2479
CASES, CARRYING	Byron Witt	2479
CASTERS	Kelly Cushing	2461
CATCHES	Paul Johnson	2473
CERAMICS, BULK & MATERIALS	Katherine Dennett	2314
CHAINS	John Thomas	2466
CHEMICALS	Katherine Dennett	2314
CIRCUIT BREAKERS	Paul Johnson	2473
CLAMPS	Paul Johnson	2473
CLIPS	Paul Johnson	2473
COATINGS	Katherine Dennett	2314
COILS Purchased Tek-Made	John Thomas Doug Gordon	2466 4414
COLLARS, CABLE	Jim Deer	2484
CONNECTORS	Phil Lee, Joe Reshey & Kelly Cushing	2474 2313 2461
CONTACTS	Phil Lee, Joe Reshey & Kelly Cushing	2474 2313 2461
COPPER	Bella Geotina	2315
CORDS, LACING	Bella Geotina	2315
CORES	Byron Witt	2479
COUNTERS	Dennis Johnson	2471
COUPLINGS	Jim Deer	2484
COVERS	Byron Witt	2479
CRT'S (154-XXX-XX)	John Thomas	2466
CRYSTALS	Byron Witt	2479
CUPS	Byron Witt	2479
CUSHIONS	Katherine Dennett	2314
DELAY LINES	Byron Witt	2479
DIALS	Dennis Johnson	2471
DIE CASTINGS, FRAMES, FRONT PANELS (426-XXXX-XX)	Bella Geotina	2315
DIODES Optoelectronics (See LED'S) High Frequency 4-Layer All Others	Alan LaValle Steve Fierro Paul Johnson Steve Fierro	2317 2308 2473 2308
DISKS	Kelly Cushing	2461
DISPLAYS	Alan LaValle	2317
DOORS	Paul Johnson	2473
DRUMS	Paul Johnson	2473
ELECTRIC COMPONENTS, MISCELLANEOUS	Jim Deer	2484
EXTENSION SHAFTS	Jim Deer	2484
EYELETS	Kelly Cushing	2461

EVALUATION ENGINEER LIST

0

COMPONENT	COMPONENT ENGINEER	EXT.
FANS	John Thomas	2466
FASTENERS	Kelly Cushing	2461
FELT (BULK)	Katherine Dennett	2314
FERRITES (CORES)	Byron Witt	2479
FERRULES	Katherine Dennett	2314
FET'S	Jerry Willard	2539
FIBER OPTICS	Louis Mahn	2549
FILM, ID	Bella Geotina	2315
FILM, PLASTIC	Bella Geotina	2315
FILTERS Air Crystal & Saw Light Line	John Thomas Byron Witt Louis Mahn Paul Johnson	2466 2479 2549 2473
FLANGES	Katherine Dennett	2314
FLIP-STANDS, CAB	Katherine Dennett	2314
FLUXES	Bella Geotina	2315
FOOT	Kelly Cushing	2461
FRAME & FRAME SECTION/PANELS	Bella Geotina	2315
FRONT PANELS (ANODIZED)	Bella Geotina	2315
FUSES & FUSE HOLDERS	Dennis Johnson	2471
GASKETS	Katherine Dennett	2314
GEARS	John Thomas	2466
GPIBS CABLES	Phil Lee	2474
GRILLES (FANS, ETC.)	John Thomas	2466
GRIPS	Paul Johnson	2473
GROMMETS	Kelly Cushing	2461
GUARDS	John Thomas	2466
GUIDES	John Thomas	2466
HAND GRIPS	Paul Johnson	2473
HAND TOOLS	Kelly Cushing	2461
HANDLES	Paul Johnson	2473
HARDWARE (WASHERS, NUTS, SCREWS)	Kelly Cushing	2461
HEADERS	Kelly Cushing	2461
HEAT SINKS	Jim Williamson	2552
HINGES	Byron Witt	2479
HOLDERS	Joe Reshey	2313
HOLDERS, LAMPS	Jim Deer	2484
HOUSINGS	John Thomas	2466
HUBS	John Thomas	2466
IMPELLERS (AIR, FAN)	John Thomas	2466
INDUCTORS	John Thomas	2466
INSERTS	Kelly Cushing	2461
INSULATION SLEEVING	Bella Geotina	2315

COMPONENT	COMPONENT ENGINEER	EXT.
INSULATORS	Bella Geotina	2315
INTEGRATED CIRCUITS (See MICROCIRCUITS)		
INTERFACE UNITS	Phil Lee	2474
JACKS	Phil Lee	2474
KEYS (CONNECTORS, LOCKS)	Kelly Cushing	2461
KEYBOARDS	Jim Deer	2484
KNOBS	Kelly Cushing	2461
KNOBS, DIAL ASSEMBLY	Kelly Cushing	2461
KNOB SKIRTS	Kelly Cushing	2461
LABELS, ID MARKERS, OVERLAYS	Bella Geotina	2315
LACING CORDS, THREAD, ETC. (BULK)	Bella Geotina	2315
LAMPS	Jim Deer	2484
LAMP HOLDERS	Jim Deer	2484
LATCHES (FORMED)	Paul Johnson	2473
LEADS (FORMED) (195-XXXX-XX)	Katherine Dennett	2314
LED'S (LIGHT EMITTING DIODES) Infared IR Detectors and Emitters Visible	Louis Mahn Louis Mahn Alan LaValle	2549 2549 2317
LENS (CAMERA)	Katherine Dennett	2314
LENS (INDICATOR LIGHT)	Jim Deer	2484
LEVERS	Kelly Cushing	2461
LIDS	Kelly Cushing	2461
LIGHT INDICATORS	Jim Deer	2484
LINKS, TERMINAL CONNECTORS	Phil Lee & Joe Reshey	2474 2313
LOCKS	Kelly Cushing	2461
LOCK WASHERS	Kelly Cushing	2461
MASKS, GRATICULE	Katherine Dennett	2314
METERS	Dennis Johnson	2471
MICROCIRCUITS Analog CCD Analog Switches AS, ALS Line Drivers & Receivers AS, ALSTTL, FAST Bit Slice Bubble Memory & Controllers CMOS Communications Circuits Comparators D/A Converters A/D Converters, DVM Devices DRAM'S and Controllers DTL EAROM'S ECL EEPROM'S Error Correcting Chips FIFO'S Flexible Diskette Controllers FPLA'S and PAL'S GPIB Interface & Buss Drivers Graphic Display Controllers/CRT	Jerry Willard Jerry Willard Ken Smith John Higley Ken Smith Gary Johnson Wilton Hart Matt Porter Jim Williamson Matt Porter Matt Porter Jim McKay Abe Ghahyasi Jim McKay Joseph Parent Jim McKay Jim McKay Joseph Parent Pat Emmons Joseph Parent Ken Smith Pete Lancashire	2539 2539 2319 2316 2319 2009 2572 2311 2552 2311 2311 2557 2319 2557 2573 2009 2573 2319 2566

EVALUATION ENGINEER LIST

COMPONENT	COMPONENT ENGINEER	EXT.
MICROCIRCUITS (Continued)		
High Speed Logic ECL Schottky, AS Line Drivers & Receivers Linear Logic (Field Programmable) (Mask Programmable)	Joseph Parent John Higley Ken Smith Gary Sargeant Pat Emmons Abe Ghahyasi	2573 2316 2319 2540 2009 2319
Low Power Logic CMOS LSTTL Magnetic Media/Process Analysis LSTTL LTTL, HTTL Memories (Electrically Alterable Non-Volatile)	Wilton Hart John Higley Phil Brothers John Higley Abe Ghahyasi Jim McKay	2572 2316 2454 2316 2319 2557
MOS NVRAM'S Op Amps PROM'S, EPROM'S & MROM'S	Joseph Parent Pat Emmons Jim Williamson & Gary Sargeant Pat Emmons	2573 2009 2552 2540 2009
Peripherals RAM Process Analysis RAM'S (Dynamic) RAM'S (Static)	Ken Smith Joseph Parent Jim McKay John Bossett Pat Emmons	2319 2573 2557 2541 2009
RAM'S (Non-Volatile) RAM'S (Pseudo Static) Regulators, Linear Regulators, Switching ROM'S (Field Programmable) (Mask Programmable)	Pat Emmons Pat Emmons Steve Fierro Jim Williamson Pat Emmons Abe Ghahyasi	2009 2009 2308 2552 2009 2319
RTL, DTL Serial & Parallel I/O STTL Tek-Made / Monolithics Tek-Made / Hybrids TTL	Abe Ghahyasi Ken Smith John Higley Joe McGrady Bob Stanton Abe Ghahyasi	2319 2319 2316 1047 3961 2319
MICROPROCESSORS		
CMOS Microprocessors Intel, Zilog Microprocessors Microprocessor Peripherals & Control Motorola Microprocessors 6801 Family Microprocessors 8035, 8048 Family Microprocessors Miscellaneous Microprocessors	Wilton Hart Wilton Hart Ken Smith Carle Teale John Higley Ken Smith Carl Teale	2572 2572 2319 2567 2316 2319 2567
MICROWAVE COMPONENTS		
	Byron Witt	2479
MOTORS & MOTOR BRUSHES		
	John Thomas	2466
MOUNTS		
	Bella Geotina	2315
MULTIPLIERS (HIGH VOLTAGE)		
	Gary Sargeant	2540
NICKEL - BERYLLIUM		
	Bella Geotina	2315
NON-METALLIC SHEETS (BULK) (252-05XX-XX)		
	Katherine Dennett	2314
NON-METALLIC SHEETS (NOT BULK) (107-XXXX-XX)		
	Katherine Dennett	2314
NUTS		
	Kelly Cushing	2461
OEM REPLACEABLE PARTS		
	Jim Deer	2484
OPERATING SUPPLIES (006-XXXX-XX)		
	Katherine Dennett	2314
OPTICAL COMPONENTS		
	Katherine Dennett	2314
OPTOISOLATORS		
	Louis Mahn	2549
OSCILLATORS		
	Byron Witt	2479
OVERLAY, PB		
	Bella Geotina	2315
PADS		
	Katherine Dennett	2314
PAINTS, VARNISH (BULK)		
	Katherine Dennett	2314
PANELS (ETCHED AND ANODIZED)		
	Bella Geotina	2315
PANELS (NOT ANODIZED)		
	Katherine Dennett	2314

COMPONENT	COMPONENT ENGINEER	EXT.
PAPER (BULK & SHEET)		
	Katherine Dennett	2314
PHOTO COMPONENTS		
	Katherine Dennett	2314
PHOTOCOUPERS & PHOTODE		
	Louis Mahn	2549
PINS		
	Kelly Cushing	2461
PIVOT ARMS		
	Paul Johnson	2479
PLASTICS, MOLDING MATERIALS		
	Bella Geotina	2315
PLASTIC RODS, TUBING, SHEET (BULK)		
	Bella Geotina	2315
PLASTIC SHEETS (NOT BULK)		
	Bella Geotina	2315
PLATES, ID & INSTRUCTION		
	Bella Geotina	2315
PLATES, MISCELLANEOUS		
	Katherine Dennett	2314
PLUGS, TELEPHONE		
	Kelly Cushing	2461
PLUGGER, SOLENOID		
	Paul Johnson	2473
POINTERS		
	Kelly Cushing	2461
POSTS, ELECTRICAL & MECHANICAL		
	Kelly Cushing	2461
POTENTIOMETERS		
	Gene Single	2544
POWER CONNECTORS		
	Dennis Johnson	2471
POWER CORDS		
	Dennis Johnson	2471
POWER SUPPLIES		
	Jim Williamson	2552
PRECIOUS METALS		
	Bella Geotina	2315
PROBES		
	Phil Lee	2474
PROTECTIVE COVERS		
	Byron Witt	2479
PULLIES		
	John Thomas	2466
PUSHBUTTONS		
	Jim Deer	2484
RACKS		
	Paul Johnson	2473
RAILS		
	Paul Johnson	2473
READOUT DEVICES		
	Alan LaVallie	2317
RECEPTACLES		
Connectors	Phil Lee & Joe Reshey	2474 2313
Power	Dennis Johnson	2471
REDUCERS (PAINT, VARNISH)		
	Katherine Dennett	2314
REDUCERS, MECHANICAL		
	Phil Lee	2474
RELAYS (MECHANICAL & SOLID STATE)		
	Paul Johnson	2473
RESILIENT MOUNTS		
	John Thomas	2466
RESISTORS		
Fixed (Including Varistors) Variable, Panel & Precision & Trimmers	Ray Powell Gene Single	2550 2544
Tek-Made, Fixed Thick Film Tek-Made, Fixed & Variable Wirewound	Clarence Smith Jim Manuel	3985 4442
RINGS		
	Kelly Cushing	2461
RINGS, KNOB SKIRT, RETAINING & TRIM		
	Kelly Cushing	2461
RIVETS		
	Phil Lee	2474
RODS, MISCELLANEOUS		
	Bella Geotina	2315
RODS, PINION		
	Bella Geotina	2315
RODS, SPACING		
	Kelly Cushing	2461
ROTATING MECHANICAL PARTS		
	John Thomas	2466
ROTORS, VARIABLE RESISTORS		
	John Thomas	2466

EVALUATION ENGINEER LIST

0

COMPONENT	COMPONENT ENGINEER	EXT.
RUBBER (BULK)	Katherine Dennett	2314
SCREENS	John Thomas	2466
SCREWS	Kelly Cushing	2461
SCR'S, SCS'S	Paul Johnson	2473
SHAFTS	Jim Deer	2484
SHEETS, NON-METALLIC (ALL)	Katherine Dennett	2314
SHELLS, KNOBS	Kelly Cushing	2461
SHIELDS (ELECTRICAL & MECHANICAL)	Katherine Dennett	2314
SHIELDING GASKETS	Katherine Dennett	2314
SHELVES	Kelly Cushing	2461
SHIMS	Jim Deer	2484
SHOCK MOUNTS	Katherine Dennett	2314
SILICONE WAFERS	Katherine Dennett	2314
SLEEVES	Katherine Dennett	2314
SLEEVES, MARKING	Bella Geotina	2315
SLEEVES, SPACER	Jim Deer	2484
SLEEVING, INSULATION	Bella Geotina	2315
SLIDES	Jim Deer	2484
SLIDES, ASSEMBLY	Jim Deer	2484
SOCKETS	Kelly Cushing	2461
SOLDER (BULK)	Bella Geotina	2315
SOLENOIDS	Paul Johnson	2473
SPACERS	Jim Deer	2484
SPARK GAPS	Paul Johnson	2473
SPRINGS	Kelly Cushing	2461
SPROCKET WHEELS	John Thomas	2466
STAINLESS STEEL	Bella Geotina	2315
STEEL (BULK)	Bella Geotina	2315
STEMS	Kelly Cushing	2461
STIFFENERS	Katherine Dennett	2314
STOPS	Paul Johnson	2473
STRAIN RELIEFS	Jim Deer	2484
STRAPS	Kelly Cushing	2461
STRIKES	Paul Johnson	2473
STRIPS (CERAMIC, FELT, TRIM, METAL, RUBBER)	Katherine Dennett	2314
STUDS	Kelly Cushing	2461
SUBPANELS	Katherine Dennett	2314
SUBSTRATES (204-XXXX-XX)	Katherine Dennett	2314
SUPPORTS	Katherine Dennett	2314
SWITCHES General Reed Assembly Key Turret	Dennis Johnson Paul Johnson Dennis Johnson Dennis Johnson Dennis Johnson	2471 2473 2471 2471 2471

COMPONENT	COMPONENT ENGINEER	EXT.
TAGS	Bella Geotina	2315
TAPE	Bella Geotina	2315
TERMINAL, BLADES	Kelly Cushing	2461
TERMINAL, BOARDS	Kelly Cushing	2461
TERMINAL LUGS	Kelly Cushing	2461
TERMINAL PINS	Joe Reshey	2313
TERMINAL STRIPS, CERAMIC	Katherine Dennett	2314
TERMINAL STRIPS	Katherine Dennett	2314
TERMINATIONS	Phil Lee	2474
THERMISTORS	Ray Powell	2550
THREADS	Bella Geotina	2315
THUMBSCREWS	Kelly Cushing	2461
THYRISTORS	Paul Johnson	2473
TIE PLATES	Paul Johnson	2473
TIE STRIPS	Paul Johnson	2473
TIN (BULK)	Bella Geotina	2315
TIPS, PROBES	Joe Reshey	2313
TRANSDUCERS	Byron Witt	2479
TRANSFORMERS Purchased Tek-Made	John Thomas Bob Cogan	2466 4416
TRANSISTORS Field Effect (FET'S) Photo Power Small Signal, Arrays Unijunction, Triacs	Jerry Willard Louis Mahn Jim Williamson Ashok Narayan Paul Johnson	2539 2549 2552 2551 2473
TRAYS	Kelly Cushing	2461
TRIM STRIPS	Katherine Dennett	2314
TUBING, HEAT SHRINKS	Bella Geotina	2315
VALVES	John Thomas	2466
VARNISH (BULK)	Katherine Dennett	2314
VENTILATING FANS	John Thomas	2466
WAFERS Processed Silicon	Katherine Dennett Katherine Dennett	2314 2314
WASHERS	Kelly Cushing	2461
WHEELS	Kelly Cushing	2461
WINDOWS	Bella Geotina	2315
WIRE, ELECTRICAL, STRIPE	Elizabeth Doolittle	2309
WIRE, BULK	Elizabeth Doolittle	2309
YOKES	John Thomas	2466

PURCHASING ROSTER

CENTRAL PRODUCTION/ENGINEERING MRO/CAPITAL/FACILITIES/SUPPLIES/SERVICES

NAME	BUYER NUMBER	EXT.	DEL. STA.
<u>PASSIVE COMPONENTS</u>			
Frank, Harriet	1C, 12	2749	78-649
Lemas, Dave	03, 1D, 42, 44, 46	2761	78-649
Ross, Glenn	1E, 28	2740	78-649
<u>ELECTRO/MECHANICAL</u>			
Elle, Dave	1F, 24, 3E	2758	78-650
Strand, Karel	05, 1P, 47	2743	78-650
Webb, Sharon	25, 3V, 33	2745	78-650
Wilkins, Rob	1B, 3D, 31	2733	78-650
<u>ACTIVE COMPONENTS</u>			
Cannon, Sue	1V, 38, 4B	2773	78-643
Hiatt, Larry	1X, 3J, 3R	2783	78-643
Roussos, George	09, 3P, 4C	2762	78-643
Ware, Donna	1T, 10	2767	78-643

NAME	BUYER NUMBER	EXT.	DEL. STA.
<u>CAPITAL & CAPITAL SERVICES</u>			
Foster, Scott	4Z	2702	78-664
Haun, Tom	4N	0443	22-780
Pearce, Chuck	4W	2777	78-664
Tripp, Paul	27	2784	78-664
<u>SUPPLIES/SERVICES</u>			
Adams, Don	04	4187	71-555
Johnson, Glenn	01, 3T, 3U	4183	71-555
Lockhart, Frances	02, 17	4190	71-555
<u>MRP/FACILITIES</u>			
Earnest, Patty	14, 18, 48	1209	71-555
Forbes, Andy	43	0442	22-780
Isaacson, Bill	22	0449	22-780
Swire, Mel	11, 4L	4186	71-555

DIVISION PURCHASING

NAME	BUYER NUMBER	EXT.	DEL. STA.
<u>IDD PURCHASING - WILSONVILLE</u>			
Banta, Ruth	34, 4G	3259	63-439
Brown, W. Kirk	1N	3258	63-439
Burgess, Steve	3X	3134	63-439
Kaylor, George	35	3254	63-439
Scott, Joe	2W	3257	63-439
Wetzler, Ron	1A	3023	63-439
<u>DAD PURCHASING - WALKER ROAD</u>			
Hoffmeister, Marge	4Y	1568	94-323
MacDanold, Mildred	1K, 39	1259	94-323
Seed, Jim	2D, 4H	1130	94-323
Stewart, Gordon	1H, 3H	1307	94-323
<u>ID PURCHASING - BEAVERTON</u>			
Dougherty, Larry	40	4185	71-555
Guthrie, Mia	2L, 2T	2736	38-846
Kinney, Marty	3L	3210	39-846
<u>TECHNOLOGY GROUP</u>			
Brown, Bill M.	1Y	1094	59-201
Eberhardt, Irene	2J, 26	6819	50-471
Fisher, Larry	2A, 23	4197	59-201
Jennings, Bob	41	4197	59-201
McDermott, Carol	4V	3914	13-856
Peterson, Art	13	6816	50-471
Stucki, Ken	2K, 20, 4M, 4X	3915	13-856
Walton, Robin	07	6826	50-471
<u>COMMUNICATIONS DIVISION</u>			
Hunt, Jan	3C	0444	58-264
Likens, Julia	2C, 4E	4598	58-264
Wilson, Harry	2V, 3F	2737	58-264
Zilk, Ed	16	1824	58-264
<u>EMCM - CLARK COUNTY</u>			
Deardorff, Clyde	1W	7370	08-545
Gardner, Don	08, 2R	7399	08-545
Lader, Billie	2P, 45	7273	08-545
McKichan, Russ	3G	7305	08-545
Scott, Wendy	2Y, 3W, 4P	5028	C1-548
<u>EMCM - BEAVERTON</u>			
Balsillie, Doug	29, 3K	3095	10-000
Bjerke, Cal	06, 3A	1381	16-298
Collier, Bob	2H, 4R	1152	16-306
Davidson, Lloyd	1G, 1J, 19, 4U	2760	78-635
Gedney, Rex	30	1146	16-298
Kaiser, Dick	2N	1151	16-306
Merrill, Art	1M, 36	0452	16-298
Olson, Norma	2B, 2E	4557	19-661
Ornelas, Tino	2F, 2G, 37	8241	32-261

NUMBER TO BUYER

NUMBER	BUYER	NUMBER	BUYER
01	Johnson	24	Elle
02	Lockhart	25	Webb
03	Lemas	26	Eberhardt
04	Adams	27	Tripp
05	Strand	28	Ross
06	Bjerke	29	Balsillie
07	Walton	3A	Bjerke
08	Gardner	3B	Wacha
09	Roussos	3C	Hunt
1A	Wetzler	3D	Wilkins
1B	Wilkins	3E	Elle
1C	Frank	3F	Wilson
1D	Lemas	3G	McKichan
1E	Ross	3H	Stewart
1F	Elle	3J	Hiatt
1G	Davidson	3K	Balsillie
1H	Stewart	3L	Kinney
1J	Davidson	3P	Roussos
1K	MacDanold	3R	Hiatt
1M	Merrill	3T	Johnson
1N	Brown, K.	3U	Johnson
1P	Strand	3V	Webb
1R	Wacha	3W	Scott, W.
1T	Ware	3X	Burgess
1V	Cannon	30	Gedney
1W	Deardorff	31	Wilkins
1X	Hiatt	33	Webb
1Y	Brown, B.	34	Banta
1Z	Kidd	35	Kaylor
10	Ware	36	Merrill
11	Swire	37	Ornelas
12	Frank	38	Cannon
13	Peterson	39	MacDanold
14	Earnest	4A	Prise
15	Goodwin	4B	Cannon
16	Zilk	4C	Roussos
17	Lockhart	4E	Likens
18	Earnest	4G	Banta
19	Davidson	4H	Seed
2A	Fisher	4J	Evans
2B	Olson	4K	Evans
2C	Likens	4L	Swire
2D	Seed	4M	Stucki
2E	Olson	4N	Haun
2F	Ornelas	4P	Scott, W.
2G	Ornelas	4R	Collier
2H	Collier	4U	Davidson
2J	Eberhardt	4V	McDermott
2K	Stucki	4W	Pearce
2L	Guthrie	4X	Stucki
2M	Young	4Y	Hoffmeister
2N	Kaiser	4Z	Foster
2P	Lader	40	Dougherty
2R	Gardner	41	Jennings
2T	Guthrie	42	Lemas
2V	Wilson	43	Forbes
2W	Scott, J.	44	Lemas
2Y	Scott, W.	45	Lader
20	Stucki	46	Lemas
21	Fritzler	47	Strand
22	Isaacson	48	Earnest
23	Fisher	49	Fink

SIX CATALOG INDEX

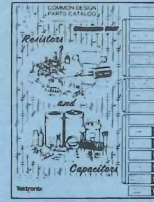

THIS IS A COMPOSITE INDEX OF THE TYPES OF PARTS INCLUDED IN THE SIX CATALOGS (SHOWN ABOVE). IT IS IN ALPHABETICAL ORDER GIVING THE CATALOG AND SECTION NUMBER THAT THE PARTS ARE LISTED IN.

C A T	S E C T	TYPE OF PARTS (ALPHA LIST)
3	4	Adhesives
4	9	Air Filters
3	5	Aluminum (Extrusion)
3	6	Aluminum (Bar, Wire, Flat, Tube)
2	15	Angle Brackets
1	3	Arrays
1	6	
1	10	Back Diodes
1	10	
4	8	Battery
2	11	Bearing (Sleeve)
2	11	Belts (Drive)
3	8 & 11	Beryllium Materials
2	3	Binding Post
4	10	
2	10	Bracket (Angle & Comp. Mounting)
2	15	
3	7	Brass Material
2	13	Bumpers
2	4	Bushings
2	9	Button Plugs
2	13	Cabinet (Instrument)
2	14	Cabinet (Fasteners)
6	5 & 6	Cables (RF, Special Purpose, Flat)
6	8	Cables (Assys, Power Cords, Ext.)
6	10	Cable Nipples
5	9-14	Capacitors, Fixed
5	15	Capacitors, Variable
1	15	Cartridge Lamp
2	13	Casters
2	14	Catches
3	4	Ceramic Materials
3	3	Ceramic Substrates
2	11	Chains (Drive)
3	4	Chemical Elements & Symbols Table
2	14	Circuit Board Ejectors
4	13	Circuit Board Interconn System
3	3	Circuit Board Laminate Materials
4	6	Circuit Breakers
2	9	Clamps
2	9	Clips
3	15	Coatings (Insulative, Resistive, Paints, etc.)
4	2	Coils
3	1	Conductive Elastomers
4	10-13	Connectors (Ckt Board, Coax, Power, D Series, Peltola, Flat Cable)
4	13	Contacts
3	10-11	Copper and Misc. Copper Alloys
3	8	Copper-Beryllium
4	2	Core (For Coils & Transformers)
2	6	Couplings, Shaft
4	1	Crystal Oscillators
4	1	Crystal Units & Holders
1	11	Current Limiting Diodes
2	13	Cushioning Pads
6	4	Delay Lines
2	7	Dial (Knob & Turns Counting)
1	10-13	Diodes
4	10	Discrete Component Carriers
PG III		EIA Date Code
1	0	Environ and Reliability Notes
3	3	Epoxy Preforms
2	8	Eyelets
4	9	Fan and Impeller (Air)
2	4	Fasteners
3	2	Felt Material
2	3	Ferrules
1	7	FET'S
4	1	Filters (RFI)
2	13	Flipstands, Cab
3	11	Flux
2	13	Foot (Cabinet)
4	2	Form (Coil & Transformer)
1	10	Four Layer Diodes
4	8	Fuses
4	8	Fuseholder and Clips

C A T	S E C T	TYPE OF PARTS (ALPHA LIST)
2	10	Gasket (RFI)
4	1	Gases (Material)
3	4	Gasses (Material)
2	11	Gears
1	15	Glow Lamps
2	4	Grommets
2	14	Guide (Pin, Ckt Bd & Instr. Cabnt)
2	13	Handles
1	5	Heat Sinks
2	14	Hinges
2	9	Holders
4	8	Holders (Battery)
4	9	Impeller (Air Fan)
1	15	Incandescent Lamps
1	15	Indicator Lights
4	2	Inductors
3	15	Ink (Marking)
2	7	Insert (Knob)
2	2	Insert (Threaded)
2	13	Instrument Cabinets
3	2-4	Insulating Materials (Bulk)
6	9	Insulating Sleeving
2	3	Insulator Post
1	5	Insulators
1	1-4	Integrated Circuits (Microcircuits)
4	13	Interconn System (For Circuit Bds)
4	10	Jack (Telephone & Tip)
2	7	Knob & Knob Subparts
2	6	Knob With Shaft
2	7	Knob Design Data
3	15	Lacquer
1	15	Lamp (Incand, Glow, Indicator)
1	15	Lampholder
2	14	Latch (Door, etc.)
6	1	Leads (Formed)
1	14	LED'S (Light Emitting Diodes)
1	15	Lens (Indicator)
2	14	Lock (Door, etc.)
1	0	Logo List
5	0	
3	15	Lubricants
4	10	Lug Terminals (Solder and Solderless)
2	4	
3	12	Magnetic Shielding Material
2	12	Marker, Identification
1	1-4	Microcircuits
1	1	Microprocessors
2	13	Modular Packaging System
4	9	Motors
1	15	Neon Lamps
3	11	Nickel Material (Bulk)
2	2	Nuts and Nut Block
1	3	Op Amps
1	14	Optoelectronic Devices
1	14	Optoisolators
2	4	"O" Rings
4	1	Oscillator (Crystal)
2	13	Pad (Cushioning)
3	15	Paint & Paint Additives
3	9	Phosphor-Bronze Material
1	14	Photoconductors
1	14	Phototransistors
2	14	Pin (Guide)
2	8	Pin (Spring and Retaining)
3	1	Plastic Materials (Bulk Molding)
3	2	Plastic (Shapes and Sheets)
2	12	Plate (Indent and Instruction)
2	3	Post (Threaded Spacers)
4	2	Pot Cores
5	6-8	Potentiometer (Variable Resistor)
6	11	Power Supplies
1	6	Power Transistors
2	2 & 3	Press Mount Hardware

C A T	S E C T	TYPE OF PARTS (ALPHA LIST)
1	0	Product Safety
4	0	
5	0	
1	8	Programmable Thyristors
2	11	Pulleys
2	7	Push Buttons
1	12	Rectifier Diodes
4	3	Relay
1	0	Reliability Notes
4	0	
5	0	
5	1-5	Resistor, Fixed
5	6-8	Resistor, Variable
2	8	Retaining Ring
4	1	RFI Filters
2	8	Rivet
1	12	Schottky Diodes
1	8	SCR Thyristors
2	1	Screws
1	All	Semiconductors
2	6	Shafts
4	10	Shields (RFI Gaskets, Ckt Boards, etc.)
2	1	
2	1	Shock Mounts
1	10	Shockley (Diodes)
1	12	Signal Diodes
2	11	Sleeve Bearing
2	14	Slide (Ckt Board & Instr. Cabinet)
1	6	Small Signal Transistors
1	10	Snap-Off Diodes
4	10	Socket (Electrical Components)
3	11	Solder
4	3	Solenoids
3	15	Solvents
2	3	Spacers (Threaded & Unthreaded)
4	8	Spark Gap
2	8	Spring (Helical)
2	11	Sprockets
3	14	Stainless Steel Material
2	3	Standoffs
3	13	Steel Material
2	4	Strain Relief Bushings
2	9	Straps
2	1	Stud (Threaded, Weld, Pressmount, etc.)
4	3-7	Switch (Lever, Slide, Push, Toggle, Reed, Thermo, Rocker, Rotary, Power, Logic, Thumbwheel, etc.)
1	12	Switching Diodes
1	8	Switching Transistors
3	4	Tape
All	0	Tek Part Number System
2	10	Terminal (Lug, Block, Grnding, Studs, Ceramic Strip, Quick Disc, Feedthru)
4	10	Thumbscrews
2	1	
All	0	Tools, Small
4	2	Transformers
1	6-9	Transistors
1	8	Triac Thyristors
1	10	Tunnel Diodes
1	8	Unijunction Thyristors
5	6-8	Variable Resistors
3	15	Varnish
1	12	Voltage Multipliers (Diodes)
4	8	Voltage Selectors (Fuse)
2	4	Washer (Flat, Lock, Spring Shldr)
6	1-3	Wire (Electrical)
1	11	Zener Diodes

EVALUATION ENGINEER LIST, PREVIOUSLY ON BACK COVER, CAN BE FOUND ON PAGES 0-70 THRU 0-73. ALSO, PURCHASING ROSTER ON INSIDE OF THIS COVER.

