

Tektronix®

**TYPE
S-1
SAMPLING HEAD**

INSTRUCTION MANUAL

Tillhör
TEKTRONIX AB
Service
08/83 00 80



**PLEASE CHECK FOR CHANGE INFORMATION
AT THE REAR OF THIS MANUAL.**

**TYPE
S-1
SAMPLING HEAD**

INSTRUCTION MANUAL

Tektronix, Inc.
P.O. Box 500
Beaverton, Oregon 97077

070-0763-00
Product Group 42

Serial Number _____

First Printing APR 1968
Revised MAY 1985

Copyright © 1968 Tektronix, Inc. All rights reserved.
Contents of this publication may not be reproduced in any
form without the written permission of Tektronix, Inc.

Products of Tektronix, Inc. and its subsidiaries are covered
by U.S. and foreign patents and/or pending patents.

TEKTRONIX, TEK, SCOPE-MOBILE, and  are
registered trademarks of Tektronix, Inc. TELEQUIPMENT
is a registered trademark of Tektronix U.K. Limited.

Printed in U.S.A. Specification and price change privileges
are reserved.

INSTRUMENT SERIAL NUMBERS

Each instrument has a serial number on a panel insert, tag,
or stamped on the chassis. The first number or letter
designates the country of manufacture. The last five digits
of the serial number are assigned sequentially and are
unique to each instrument. Those manufactured in the
United States have six unique digits. The country of
manufacture is identified as follows:

B000000	Tektronix, Inc., Beaverton, Oregon, USA
100000	Tektronix Guernsey, Ltd., Channel Islands
200000	Tektronix United Kingdom, Ltd., London
300000	Sony/Tektronix, Japan
700000	Tektronix Holland, NV, Heerenveen, The Netherlands

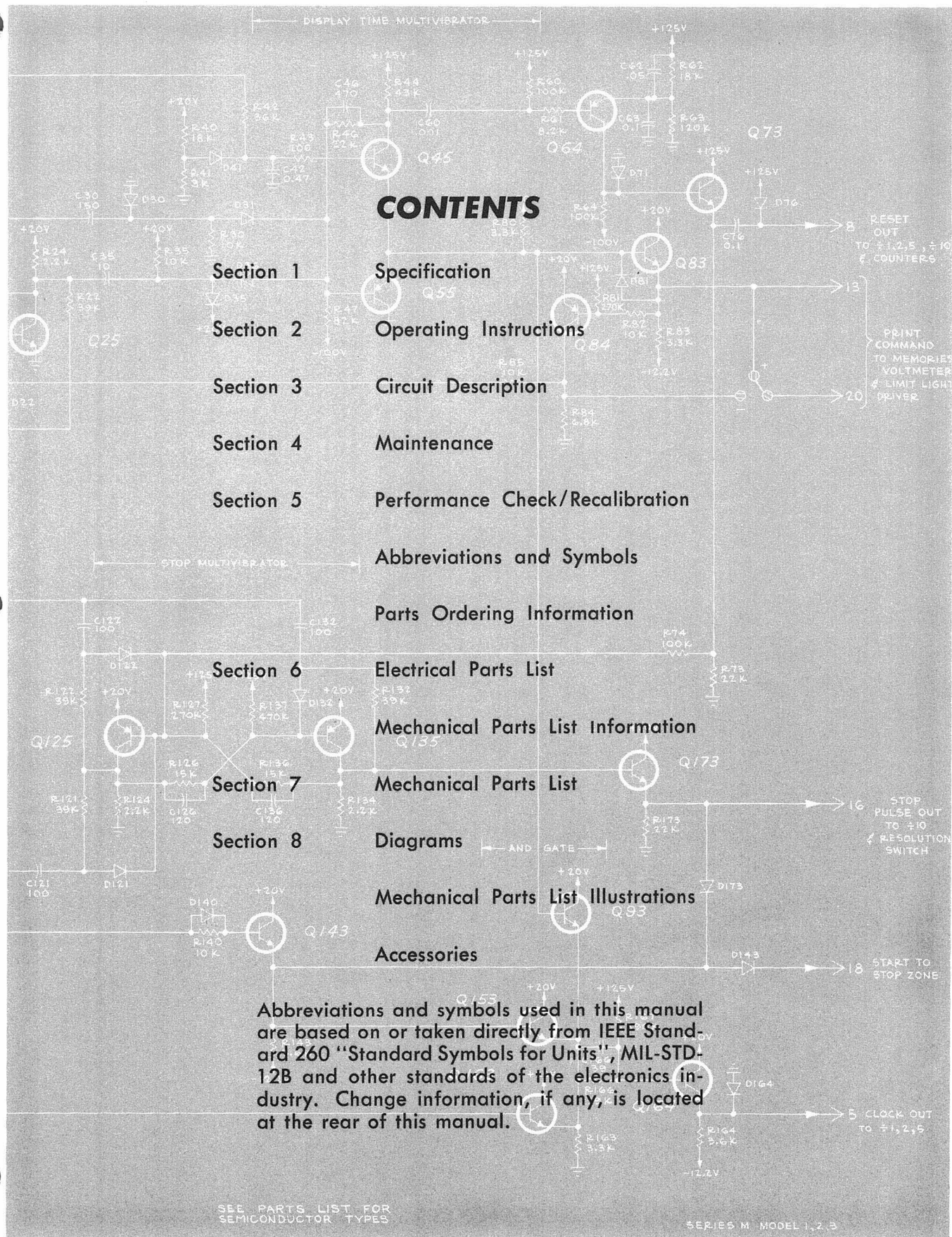

CONTENTS

- Section 1 Specification
- Section 2 Operating Instructions
- Section 3 Circuit Description
- Section 4 Maintenance
- Section 5 Performance Check/Recalibration

- Abbreviations and Symbols
- Parts Ordering Information

- Section 6 Electrical Parts List
- Section 7 Mechanical Parts List Information
- Section 7 Mechanical Parts List
- Section 8 Diagrams

- Mechanical Parts List Illustrations
- Accessories

Abbreviations and symbols used in this manual are based on or taken directly from IEEE Standard 260 "Standard Symbols for Units", MIL-STD-12B and other standards of the electronics industry. Change information, if any, is located at the rear of this manual.

SEE PARTS LIST FOR SEMICONDUCTOR TYPES

SERIES M, MODEL 1,2,3



Fig. 1-1. Type S-1 Sampling Head.

SECTION 1

TYPE S-1 SPECIFICATION

Change information, if any, affecting this section will be found at the rear of the manual.

General Information

The Type S-1 Sampling Head is a 50 Ω input, 350 ps rise-time, plug-in preamplifier for use in some Tektronix 3S-series sampling units, such as the Type 3S2 Sampling Unit. Input characteristics of the sampling system are controlled by the type of sampling head in use.

The Type S-1 can be installed directly into the Type 3S2, or used remotely on an optional 3 foot or 6 foot extender cable. Vertical deflection factor of the sampling system is labeled at the top of the Type S-1 as mVOLTS/DIV; the label refers to the sampling unit Units/Div switch that is directly above the head.

A portion of the input signal is provided to the Type 3S2 Sampling Unit for externally triggering a Type 3T2 Random Sampling Sweep. The Type 3S2 allows selection of the trigger pickoff signal from the Channel A or Channel B sampling head. The selected trigger pickoff signal is returned to the Type 3S2 front panel at the Trig Out connector. The trigger pickoff signal is useful with any sampling sweep unit for repetitive signals where the triggering event does not have to be displayed. (Only the Type 3T2 random process

sampling allows the triggering event to be displayed using the sampling head trigger pickoff signal.)

Digital Unit Program Connections

The Type S-1 contains connections at its rear that program both the decimal and the units lamps of a Type 230 Digital Unit. The S-1 digital control connections pass through the Units/Div switch of either the Type 3S5 or Type 3S6 Programmable Sampling Unit, and through the Type 568 Oscilloscope to the Type 230 Digital Unit.

ELECTRICAL CHARACTERISTICS

The following characteristics apply over an ambient temperature range of 0°C to +50°C. These characteristics apply only after the Type S-1 has been properly mated to the sampling unit and indicator oscilloscope, and after sufficient warmup time. For the particular system warmup requirements, refer to the related amplifier and indicator oscilloscope instruction manual. (A 5 minute warmup time is required for Type 3S2-3T2). A procedure for mating the Type S-1 to the vertical amplifier can be found in the Operating Instructions section of this manual.

ELECTRICAL CHARACTERISTICS

Characteristics	Performance Requirement	Supplemental Information
Input Resistance and Capacitance	50 Ω within 1% from +20° C to +30° C ambient, within 2% from 0° C to +20° C and from +30° C to +50° C, shunted by approximately 0.4 pF.	Measured at DC
Loop Gain	Adjustable in the sampling unit to unity for signals up to 500 mV P-P; when the plus dot response is adjusted for unity loop gain, the minus dot response will be within 5% of unity loop gain, and vice versa.	
Operating Input Voltage Range	+1 V to -1 V, with \leq 1 V P-P signals. Step signals greater than 500 mV require more than one dot to display 100% of the step transition.	
Maximum Input Voltage	\pm 5 VDC or sinewave of 10 V P-P up to 10 MHz.	
Transient Response		
Risetime	350 ps or less, 10% to 90%.	
Pulse Flatness Deviation	\leq + 0.5 and - 3% in the first 5 ns after the step pulse reaches 50%.	Applies when the step pulse is Tektronix Type 284 Pulse Output signal through a 20 cm airline.
	\leq + and - 0.5% after the first 5 ns.	
Displayed Noise	2 mV or less, tangential noise.	
Trace Baseline Vertical Shift with Trigger Repetition Rate Change.	10 mV or less for trigger rate change from 30 Hz to 50 kHz.	

SECTION 2

OPERATING INSTRUCTIONS

Change information, if any, affecting this section will be found at the rear of the manual.

General Information

This section provides the basic information required for operation of the Type S-1 Sampling Head, including installation and First Time Operation.

The Type S-1 completes the circuitry of some Tektronix sampling units, and controls the input characteristics of the vertical channel by providing the Strobe Generator, Sampling Bridge, and Preamplifier circuits. Such a sampling unit is the Type 3S2, using one or two S-series sampling heads. A Type 3S2 and a sampling sweep unit plugged into an indicator oscilloscope completes the sampling system. A choice of real or equivalent time sampling is provided by the type of sweep unit used.

A $50\ \Omega$ input resistance allows the use of $50\ \Omega$ attenuators and probes for operation over a wide range of signal voltages.

A portion of the input signal is provided to the sampling unit. In the Type 3S2, this signal is selected from Channel A or B, and returned to the front panel Trig Out connector for external triggering of sampling sweep units.

Installing the Type S-1 Sampling Head

Fig. 2-1 shows the Type S-1 partially installed into a Type 3S2 Sampling Unit with Type 561A Oscilloscope and Type 3T2 Random Sampling Sweep. The sampling head (or heads) can be plugged into the sampling unit as shown, or used remotely on a special extender cable. Three and six foot extender cables are available. Order the three foot extender cable by Tektronix Part No. 012-0124-00, or the six foot extender cable by Tektronix Part No. 012-0125-00. Contact your local Tektronix Field Engineer or Representative for price and availability of these optional accessories.

To insert the Type S-1 into the right or left hand compartments of the sampling unit, proceed as follows:

1. Pull the latch knob (Fig. 2-1) outward from the front panel (the latch knob will push out normally when the unit is inserted if the knob is left free to move).
2. Insert the Type S-1 slowly into the compartment, so the two plastic guides in the compartment engage the S-1.
3. Push the Type S-1 completely into the compartment.
4. Push the latch knob to lock the S-1 in place.

To remove the Type S-1 from the compartment, pull the latch knob away from the front panel, then pull the unit from the compartment.

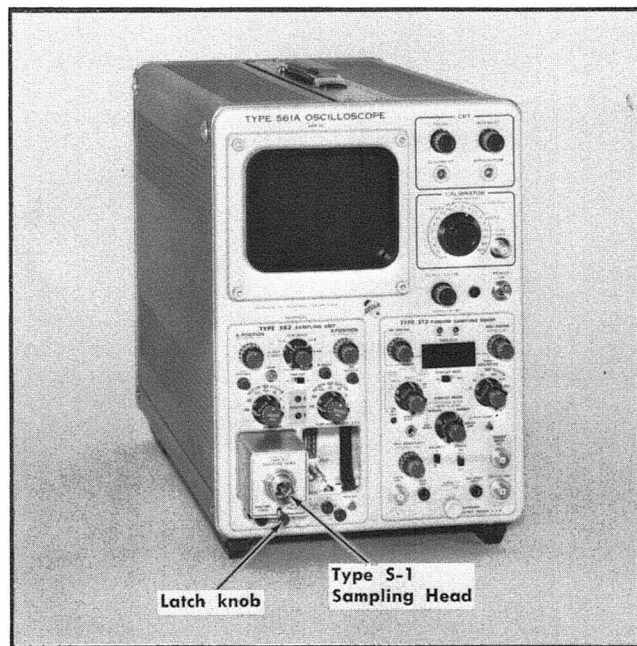

Fig. 2-1. Installation information.

To use the Type S-1 on an extender cable, install as follows:

1. Pull the latch knob located on the head end of the extender cable outward from the panel (the latch knob will push out normally when the extender is inserted if the knob is free to move).
2. Insert the extender cable head end slowly into the desired compartment in the sampling unit so the two plastic guides in the compartment engage the unit.
3. Push the head completely into the compartment.
4. Push the latch knob to lock the extender cable head end in place.
5. Connect the Type S-1 to the other end of the extender cable in a similar manner, and set the latch knob to hold it in place.
6. To remove the Type S-1 from the extender cable, pull the latch knob on the front panel of the Type S-1, and remove the unit from the extender cable.
7. To remove the extender cable head from the sampling unit compartment, pull the latch knob outward from the front panel, then pull the unit free.

Operating Instructions—Type S-1

Mating

The vertical deflection factor labeled by the Type S-1, and the sampling system loop balance (adjusted by the Bridge Bal control) must be considered when mating a Type S-1 with a sampling unit.

The mVOLTS/DIV label on the Type S-1 names the deflection factor units of the sampling unit Units/Div switch located directly above the label. For example, with the Type S-1 installed in a Type 3S2 and the Units/Div switch set at 100, each major division of CRT deflection corresponds to 100 millivolts of input signal (when the Variable control is in the Cal position). The deflection factor is mated to the indicator oscilloscope CRT by adjusting the sampling unit Gain control while the Type S-1 is in Channel B. Refer to the sampling unit manual for its Gain adjustment. Power supplies and circuit interconnections are made through the two connectors at the rear of the Type S-1.

Bridge Balance

The Bridge Balance control of the Type S-1 should be adjusted whenever the sampling head is changed from one sampling unit to another, or is operated on an extender cable. Location of the control and details of its adjustment are described in First Time Operation which follows.

FIRST TIME OPERATION

The First Time Operation procedure utilizes, in addition to the Type S-1, a Type 3S2, Type 561A, and Type 284. The Type 3T2 Random Sampling Sweep unit is recommended for use with the Type S-1 because random sampling permits viewing the signal in advance of the triggering event. Such trigger lead-time is required by the Type S-1 with the Type 3S2 to view fast pulses without a pretrigger. The Type 284 is used as a signal source.

Setup Information

1. With the Type 561A Power switch off, insert a Tektronix Type 3S2 Sampling Unit into the vertical compartment (left) and a Tektronix Type 3T2 Random Sampling Sweep into the horizontal plug-in compartment (right).

2. Insert the Type S-1 Sampling Head into Channel A compartment (left) in the Type 3S2 leaving the latch knob free to move. Once the S-1 is seated, push the latch to lock it in place.

3. Set the Intensity control on the Type 561A fully counter-clockwise.

4. Connect the Type 561A to a power source which meets its voltage and frequency requirements.

5. Set the Power switch to On. Allow about 5 minutes warm-up so the units reach operating temperature before proceeding.

6. For single-trace operation, set the controls as follows:

Type 3S2

Display Mode	CH A
Normal-Smooth	Normal

A and B Position	Midrange
DC offset (both channels)	Midrange (5 turns from one end)
Units/Div (both Channels)	200
Variable (both Channels)	Cal
Invert (both Channels)	Push in
Dot Response (both Channels)	Midrange
B Delay	Midrange

Type 3T2

Horiz Position	Midrange
Samples/Div	9 o'clock position
Display Mode	Normal
Start Point	With Trigger
Sweep Rate	200 ns/Div
Range	10 μ s
Display Mag	$\times 1$
Time Magnifier	$\times 5$
Variable	Cal
Time Position	Both fully clockwise
Trig Sensitivity	Fully clockwise
Recovery Time	Optional
Trigger Polarity	+
Trigger Source	Ext

Type 284

Square Wave Amplitude	1.0 V ¹
Period	1 μ s
Mode	Square Wave Output
Lead Time	Optional

7. Connect the square wave output signal from the Type 284 to the input connector of the Type S-1 through a 50 Ω coaxial cable and a $\times 2$ attenuator. Connect the trigger output signal from the Type 284 through a coaxial cable to the External Input 50 Ω connector on the Type 3T2.

8. Advance the Type 561A Intensity control until the free running trace brilliance is at the desired viewing level.

9. Center the trace on the graticule with the Type 3S2 A Position control and/or the DC Offset control. Adjust the Type 3T2 Trig Sensitivity control for a stable triggered display of a two-cycle square wave with an amplitude of about 2.5 divisions.

Adjusting Dot Response
Sequential Sampling

One method of adjusting the dot response for unity loop gain is to use a double or multiple-triggered sweep. This causes each sample to respond to the full signal amplitude and produce a display similar to Fig. 2-2A or B.

10. To obtain a display similar to that of Fig. 2-2A or B, turn the Type 3T2 Trig Sensitivity control clockwise into the

¹Used through X2 attenuator for 0.5 V into the Type S-1.

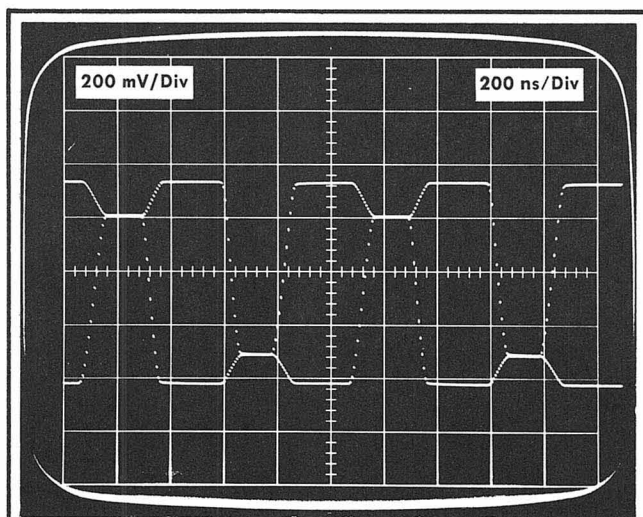
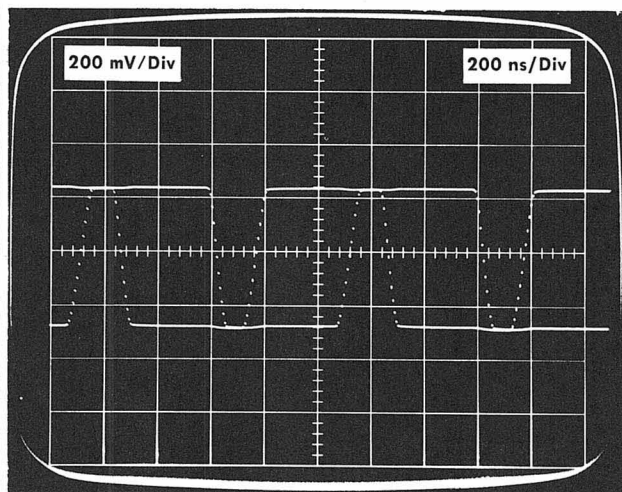
(A) Double-triggered, $>$ unity loop gain.

(B) Double-Triggered, unity loop gain.

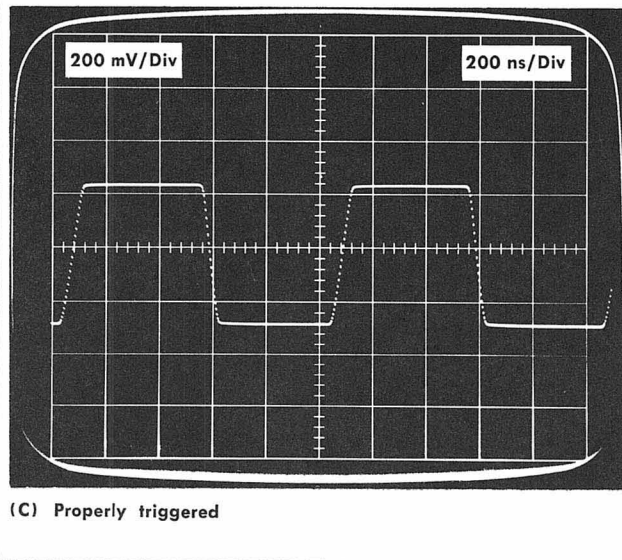

(C) Properly triggered

Fig. 2-2. Typical display for unity dot response adjustment in normal sequential sampling.

free run region. Then adjust the Recovery Time control until the desired display appears.

11. Turn the Channel A Dot Response control to obtain a display showing unity dot response (see Fig. 2-2B). Fig 2-2A shows greater than unity dot response. This requires counterclockwise rotation of the Dot Response control to obtain unity dot response. The double triggering shown in Fig. 2-2A and B is useful to adjust the dot response to unity, but should not be used in making measurements.

12. After the dot response is adjusted to unity, turn the Trig Sensitivity control counterclockwise into the triggered region for a stable trace of a properly triggered display similar to Fig. 2-2C.

Random Sampling

13. Another convenient method of adjusting the dot response to unity can be shown with random process sampling. Change the following controls:

Type 3T2

Start Point	Before Trigger
Time Magnifier	$\times 50$

Type 284

Period	100 ns
--------	--------

14. A dot response greater than unity will produce a display similar to Fig. 2-3A. Dot response deviations from unity are best observed when the Type 3T2 Time Magnifier is set at $\times 20$ or $\times 50$. Adjust the Type 3S2 Dot Response control for a unity dot response display similar to Fig. 2-3B.

Bridge Balance Adjustment

15. Connect a bench multimeter set for ≈ 30 V full scale between ground and the Type 3S2 Channel A Offset jack. Adjust the Type 3S2 DC Offset control until the multimeter reads 0 Volts. Increase the meter sensitivity and repeat the adjustment for greater accuracy.

16. Disconnect the coaxial cable from the Type 284, leaving the other end of the cable connected to the Type S-1 input connector. Turn the Type 3S2 Trig Sensitivity control clockwise to free run the trace.

NOTE

Operating the sampling head without the input connector terminated by a 50Ω resistor or coaxial cable will cause a vertical shift of the zero signal baseline by a few millivolts. This is caused by the strobe kickout signal being reflected from the open input connector, and arriving back at the sampling bridge while the bridge is conducting. Because of this phenomena, set the display zero reference point with the input circuit terminated. Also use at least 20 cm airline between the Type S-1 input and any tunnel-diode pulse generator or circuit that is sensitive to signals centering its output circuit.

Operating Instructions—Type S-1

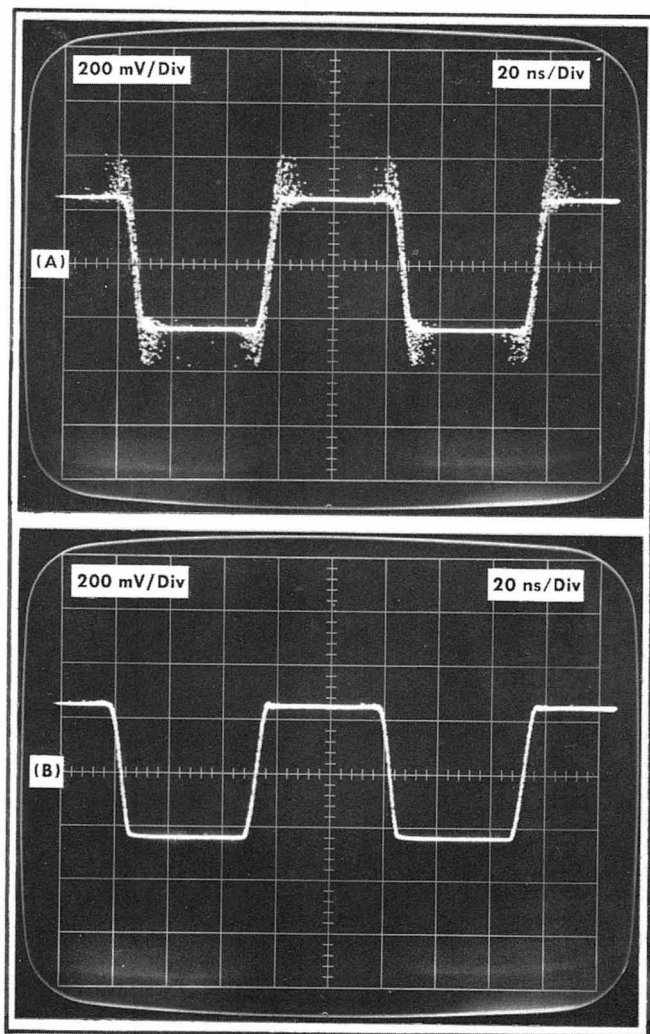

Fig. 2-3. Random process display (A) Loop gain > 1 . (B) Loop gain $= 1$.

17. Switch the Type 3S2 Units/Div control throughout its range, adjusting the Type S-1 Bridge Bal control for a trace shift of not over one division as the Units/Div control is switched from one end to the other. See Fig. 2-4 for the location of the Bridge Bal control. This adjustment must be made whenever the Type S-1 is shifted from one sampling unit to another, or operated on a sampling head extender cable.

GENERAL OPERATING INFORMATION

Input Signal Connection Precautions

Accurate displays of signals containing very fast transitions or very high frequencies are possible only when the coupling circuit does not distort the signal. The Type S-1 input resistance is $50\ \Omega$ requiring the use of high quality $50\ \Omega$ coaxial cables and attenuators between the signal source and the sampling head input connector. Tektronix, Inc. offers several special probes that permit the signal source loading to be less than caused by the $50\ \Omega$ input

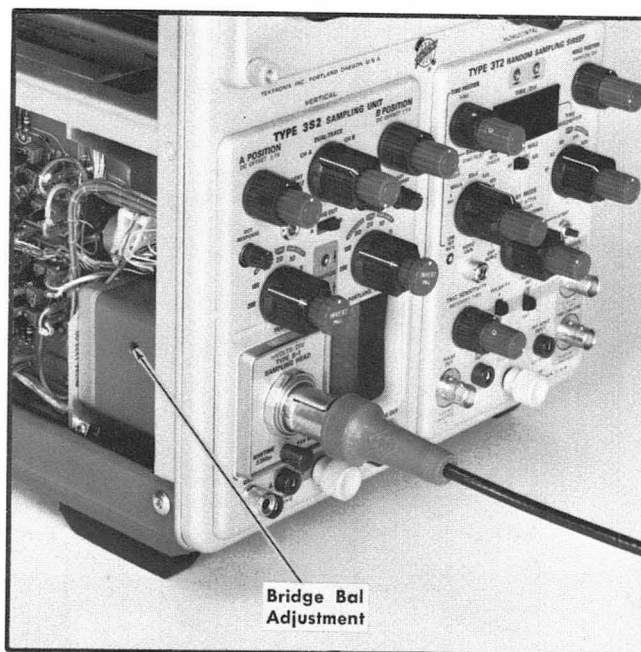

Fig. 2-4. Bridge Bal Location.

resistance. See your Tektronix Field Engineer or Representative about such special input coupling devices.

Input Voltage Considerations

Proper displays of various signal amplitudes require special attention to the type of time base generation in use. There are also input voltage limits that must be observed to prevent either display distortion or damage to the Type S-1.

For greater details on coupling of high frequency input signals, and on precautions to be observed, refer to the sampling unit Instruction Manual supplied with your sampling instruments.

Maximum input signal voltage is an important consideration in any sampling system. Signals greater than $+1$ or -1 volt generally will not permit a valid display. Thus any signals of greater amplitude should be attenuated in some manner before being applied to the Type S-1 input connector. Maximum input voltage without damage to the input termination resistor is $+5$ or -5 volts DC, or 10 volts peak to peak sine wave signals in the frequency domain of 10 MHz or below.

Where unity loop gain displays are required, accurate displays are possible only when the input amplitude and the time base generator mode are both considered. The two time base generation modes are (1) normal process sampling, where each dot is displayed in sequence across the CRT, and (2) random process sampling where the dots are not necessarily displayed in a sequence that progresses uniformly across the CRT. (The Type 3T2 Random Sampling Sweep unit presents random process sampling displays in a controlled sequence very similar to normal process sampling when the Time Magnifier switch is at $\times 1$ or $\times 2$ and the trigger signal repetition rate is uniform.) The random process dot se-

quence is definitely not sequential when the Time Magnifier switch is anywhere between $\times 5$ and $\times 50$, with the dot presentation completely random at $\times 50$. The Type 3T2 can be operated in a normal process mode, and all other Tektronix sampling sweep units generate only a normal process sequential dot display.

Unity loop gain displays are not usually required when the signal rate of rise and the sweep rate selected provide a large number of dots for any vertical display change. Unity loop gain is required for some random process sampling displays, and for normal process displays where there are either no samples, or less than about 6 samples in a step transition. Many dots in any vertical change permits valid random process displays without unity loop gain when the Type 3T2 Time Magnifier is at $\times 1$ or $\times 2$.

In summary, unity loop gain exists when the vertical channel (sampling head and sampling unit) will accurately shift a sample dot 100% of the signal amplitude. The Specification Section lists the loop gain linearity limits as $\pm 5\%$ for certain limited signal amplitudes discussed below. A 5% loop gain linearity means that the vertical channel will shift a dot in the positive direction 100% of the full signal amplitude, but minus transitions may shift a dot between -95% and -105% of the full signal amplitude, and vice versa. (The sampling unit Dot Response control thus allows either the display top or bottom to be adjusted for unity loop gain for close examination of signal detail.) Unity loop gain is obtained by proper adjustment of the sampling unit Dot Response control as described in First Time operation.

Input signal amplitude limits for unity loop gain within the 5% linearity tolerance are listed in Table 2-1. The input voltage columns are for signal amplitudes of 0.5 V peak to peak and 1.0 V peak to peak anywhere between +1 V and -1 V DC.

TABLE 2-1

Input Signal Amplitude Limits Allowing Unity Loop Gain Vs Sampling Unit mVOLTS/DIV Deflection Factor

Sampling Unit Units/Div Switch	Input Voltage	
	0.5 V P-P	1.0 V P-P
All positions 200 to 2	yes	no
	Either Normal or Random Process	
Limited to positions of 20 to 2	yes	yes
	Either Normal or Random Process	
All positions 200 to 2	yes	yes
	Normal Process only with >6 dots in a 100% vertical transition.	

Triggering from the Signal

The Type S-1 provides a trigger pickoff signal to the sampling unit. This signal is a portion of the input signal.

In the Type 3S2, the signal is selected from the Channel A or Channel B sampling head and returned to the front panel

Trig Out connector by the trigger circuit. The amplitude is about 10% of the input signal into $50\ \Omega$. A small amount of the sampling bridge strobe signal is present with the trigger signal.

A Type 3S2 standard accessory trigger coupling cable can be used between the Type 3S2 and Type 3T2 for triggering the sampling sweep unit from the sampling head pickoff signal. Connect the cable between the Type 3S2 Trig Out connector and the Type 3T2 $50\ \Omega$ Trigger Input connector. Operate the Type 3T2 as if externally triggered. Repetitive sine or square wave displays are best viewed when operating the Type 3T2 Start Point switch at With Trigger (normal process sequential dot sampling).

Fast pulse signals require random process sampling with the Type 3T2 Start Point switch at Before Trigger. This mode of operation will permit the sampling bridge strobe signal portion of the trigger pickoff signal to sometime trigger the timing unit. When this occurs, it is impossible to obtain a meaningful display. Signal amplitude to the Type S-1 must be greater than about 300 mV peak to peak in order to obtain valid displays of fast pulses during random process sampling. It is usually more satisfactory to obtain some other form of pretriggering for the sampling sweep unit when it is necessary to view fast signals.

Measuring Risetime

The Type S-1 is useful to show risetime and detect aberrations of signals in circuits that are properly coupled to the Type S-1. The risetime of both the generator (or source), and the Type S-1 must be taken into consideration.

Signals with risetimes as fast as about 0.8 ns (800 picoseconds) can be measured using the Type S-1 without any special considerations. Read the 10% to 90% risetime directly from the CRT (or digital unit) to know the risetime of the signal.

Signals with risetime faster than about 0.8 ns can be best measured using a Tektronix Type S-2 Sampling Head. However, fair approximations of risetime can be made using the Type S-1 and calculating the signal risetime by formula (1) below. Formula (1) is based upon both the signal and the sampler having Gaussian risetime characteristics. The Type S-1 risetime is actually trapezoidal, with a very linear rise and sharp corners. Signals with risetimes in the order of 50 ps will cause the sharp corners on the Type S-1 display to be quite obvious and signals with risetimes in the order of 80 to 100 ps will only modify the risetime display corners. Thus, it is recommended that displays with risetimes faster than 0.8 ns not be used to accurately measure the signal 10% to 90% rate of rise. The Performance Check and Recalibration Procedure gives equipment, procedure and displays of Type S-1 and Type S-2 risetime when driven by a 50 ps risetime tunnel diode pulser signal.

Formula (1)

$$T_r (\text{Displayed}) = (\text{Signal } T_r)^2 + (\text{Type S-1 } T_r)^2$$

transposing:

$$\text{Signal } T_r = (\text{Display } T_r)^2 - (\text{Type S-1 } T_r)^2$$

SECTION 3

CIRCUIT DESCRIPTION

Change information, if any, affecting this section will be found at the rear of the manual.

General Information

This section of the manual contains a block diagram analysis of the Type S-1 Sampling Head followed by a detailed circuit description. The Type S-1 Sampling Head is designed to be the signal input section of the sampling system. The reader may find it helpful to refer to the associated sampling unit manual for information on sampling principles if the purpose of a particular circuit is not clear. For example, Type 3S2 manual, Section 4, "Basic Sampling Principles". The sampling unit manual also shows interconnections and circuits referred to in this section. Schematic and block diagrams of the Type S-1 are located at the rear of this manual.

BLOCK DIAGRAM

Strobe Generator

The Strobe Generator develops fast-rise short-duration push-pull pulses that drive the Sampling Bridge into balanced conduction. Output occurs at the time of each sample when a command pulse arrives from the Delay and Strobe Driver circuit of the associated sampling unit. Shape and amplitude of the output strobe pulses is set by the Avalanche Volts and Snap-off Current controls. Strobe pulse duration is fixed by the two shorted clipping lines.

Sampling Bridge

The Sampling Bridge allows no connection other than the normal stray capacitance of the bridge between the input connector and the Preamplifier input except when driven into conduction by the Strobe Generator. When the Strobe Generator drives the Sampling Bridge into conduction, a portion of the signal across the Sampling Bridge is applied to the Preamplifier input.

Reverse bias is applied to the Sampling Bridge diodes by the Bridge Volts and Bridge Bal circuit. The sampling system feedback signal and DC Offset voltage is applied to the Sampling Bridge output side and the Preamplifier input through the biasing network.

Blow-by and Trigger Pickoff

The primary function of the Blow-by and Trigger Pick-off circuit is to cancel capacitively-coupled unwanted signals that normally bypass the Sampling Bridge. Very high frequencies pass to the Preamplifier input by the normal stray capacitances of the Sampling Bridge. These unwanted signals are called "blow-by".

The Blow-by circuit receives an attenuated portion of the input signal, amplifies and inverts the signal, and applies it, as a blow-by correction signal, through a capacitor to the output terminal of the Sampling Bridge. Magnitude of the blow-by correction signal is adjusted by the Transient Response control to effectively cancel the capacitively-coupled blow-by signal.

The trigger pickoff function of the Blow-by and Trigger circuitry provides a signal source for externally triggering the sampling sweep unit. The trigger pickoff circuit output signal drives an additional amplifier and channel selector circuit in the sampling unit.

Preamplifier

The Preamplifier circuit both amplifies and time-stretches the signal it receives from the Sampling Bridge. The signal received is a portion of the difference between the Feedback with the DC Offset voltage and the input signal. This "error signal" is amplified and AC coupled to the Post Amplifier in the sampling unit. The Preamplifier gain is adjustable to aid in setting the overall sampling head and sampling unit "loop" gain unity for proper dot response.

CIRCUIT DESCRIPTION

The Type S-1 Sampling Head uses the power supplies of the indicator oscilloscope and associated sampling unit. Interconnections to some of the circuits in the sampling unit are by two connectors at the rear of the sampling head. This Circuit Description covers the circuits of the Type S-1, and refers to circuits within the sampling unit. Reference to the sampling unit instruction manual diagrams and circuit description may be useful to fully understand the circuit relationships.

Strobe Generator

The Avalanche Strobe Generator circuit is located on the Strobe board. This circuit produces the push-pull strobe pulses that drive the Sampling Bridge through two equal transmission lines. See Fig. 3-1.

This Avalanche circuit converts the Strobe Drive pulse from the sampling unit to very fast push-pull strobe pulses.

The Strobe Drive pulse is transformer-coupled by T75 to the base and emitter of the Avalanche transistor Q69. Two outputs are AC-coupled from Q69, one from the collector

Circuit Description—Type S-1

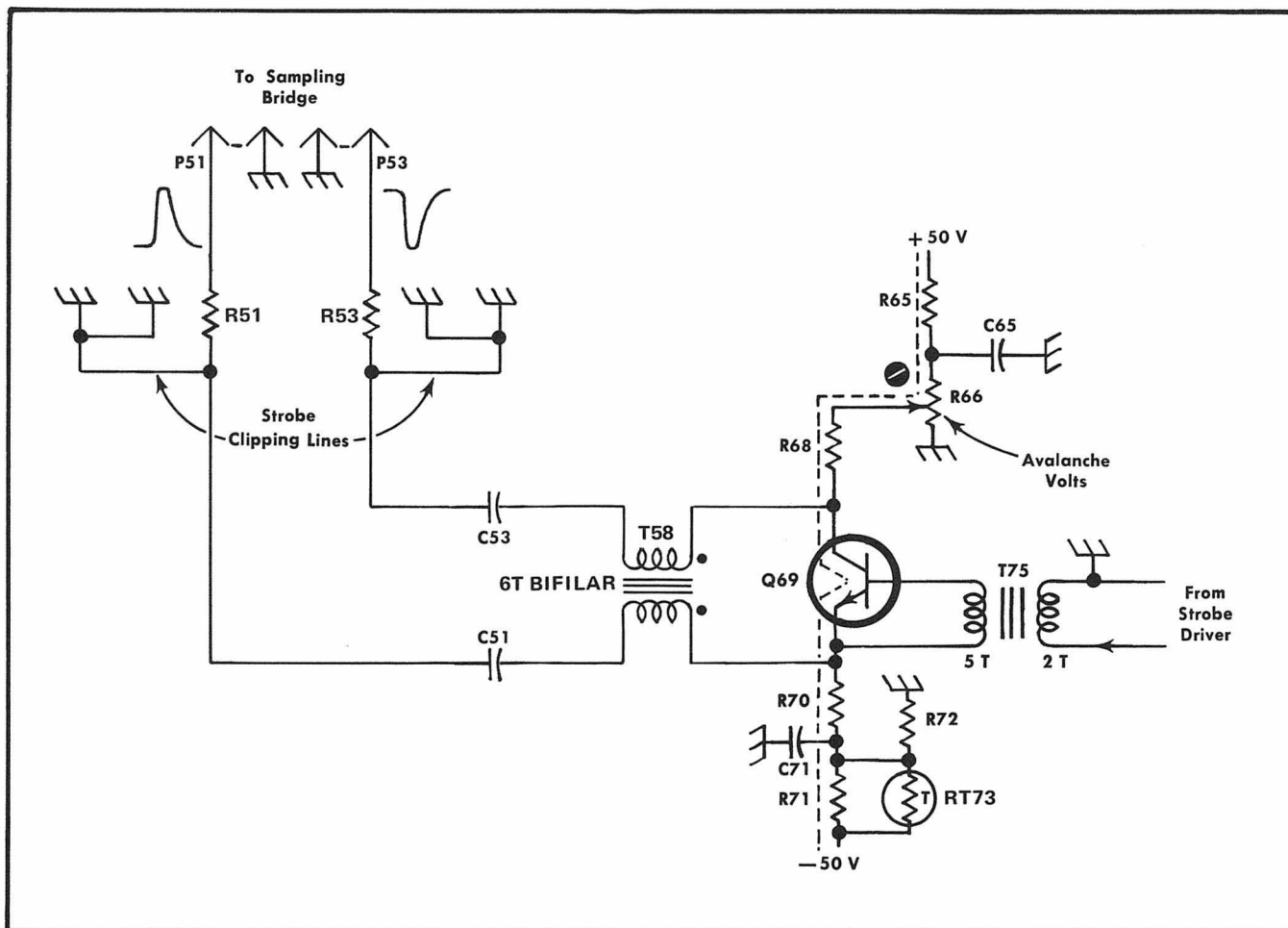

Fig. 3-1. Strobe Generator circuits.

and the other from the emitter. The Avalanche Volts control adjusts the collector voltage of Q69. The typical quiescent voltage at Q69 collector is about +15 volts. This voltage sets the amplitude of the output Strobes, and assures the normal avalanche action of Q69 when driven by the Strobe Drive signal. Q69 current path is shown by a dashed line in Fig. 3-1. Before Avalanche conduction, there is a potential of about 60 volts between collector and emitter.

The negative Strobe Drive pulse is transformer-coupled by T75 to the emitter and the base of Q69, forward biasing Q69. Normal avalanche action follows with the collector going negative and the emitter going positive. This fast-rise

push-pull signal is transformer and capacitor coupled to the Clip lines by T58, C51, and C53.

The fast-rise step which appears at each clipping line input is propagated down the line. A finite period of time later the steps reach the short circuit ends of each clipping line. The step is then reflected, equal in amplitude and opposite in polarity, back to the transmission line. This cancels the signals moving toward the Sampling Bridge. This action results in a positive Strobe pulse being delivered to P51, and a negative Strobe pulse being delivered to P53 through R51 and R53, respectively. These coupling resistors act as back terminations for the Strobe transmission lines and can be positioned on their respective clip lines for good strobe drive balance.

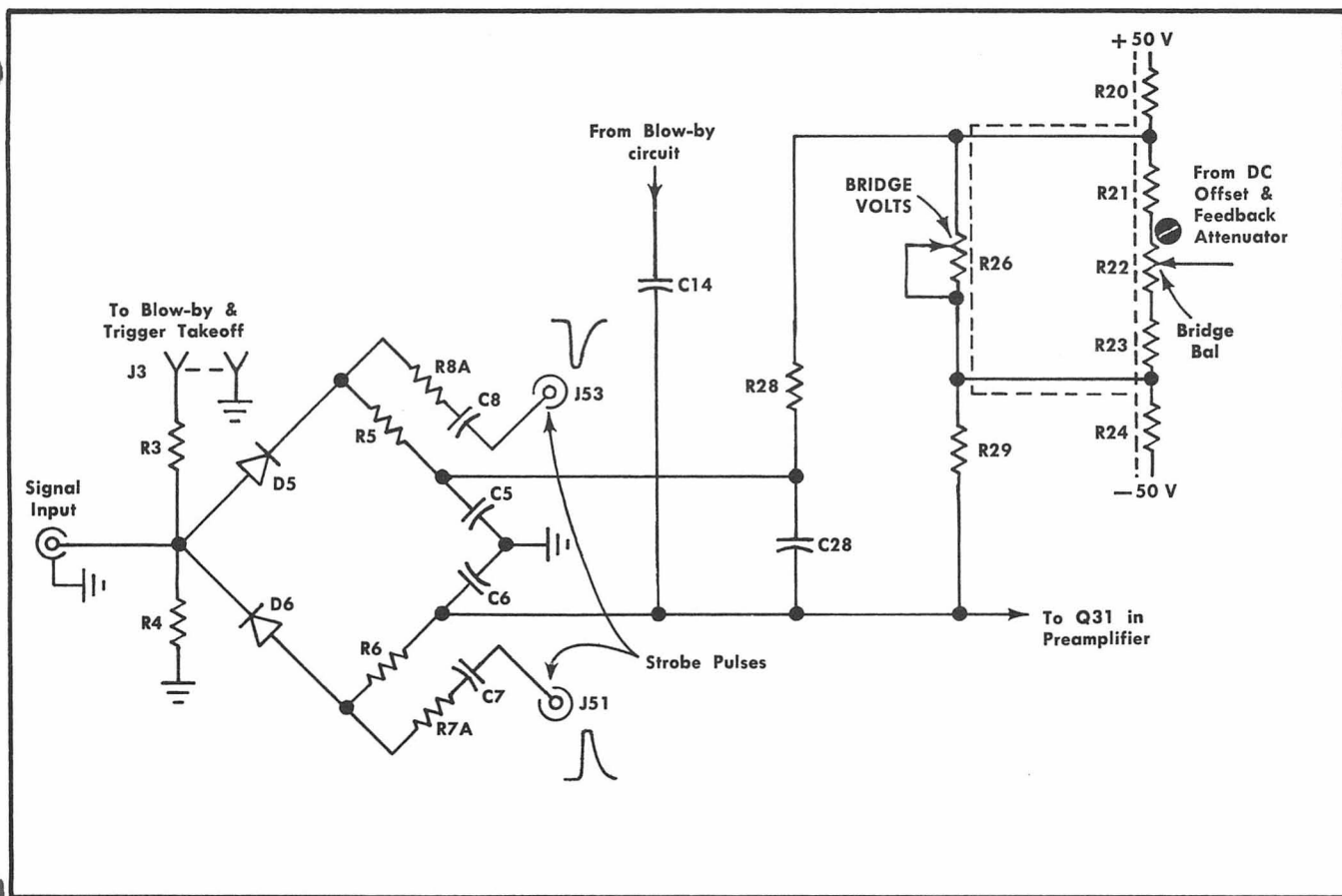

Fig. 3-2. Sampling Bridge circuit with Bridge Volts and Bridge Bal circuits.

Sampling Bridge

The Sampling Bridge consists of D5, D6, R5, R6, R7A, R8A, C5, C6, C7, C8, and C28. See Fig. 3-2. The Sampling diodes allow no connection between the input connector and the Preamplifier input (other than the normal stray capacitance of the bridge) except when driven into conduction by the strobe pulses from the Strobe Generator. During D5 and D6 conduction time of about 350 ps, the bridge delivers a portion of the voltage difference between the input signal and the bridge output signal to the Preamplifier input.

The bridge input circuit is terminated in 50 Ω . The 50 Ω consists of R4 with the series value of R3 and R10 in parallel. (R10 is shown in Fig. 3-3). R3 delivers a small portion of the input signal to the Blow-by and Trigger Pick-off circuit. The bridge output drives the high input impedance of Q31 gate in the Preamplifier.

Reverse-bias voltage for the sampling bridge diodes is developed across R21-R22-R23 in parallel with R26, the Bridge Volts control. R26 allows the reverse-bias voltage adjustment. A higher reverse voltage allows D5 and D6 to be turned on for a shorter period of time. A lower voltage gives a longer conduction time. During calibration the voltage is usually set nearly to maximum.

The Bridge Bal potentiometer is adjusted to compensate for diode, strobe, and other system unbalance signals. The

combined memory feedback and DC Offset voltage from the sampling unit is fed through the bridge volts circuit to the output of the Sampling Bridge.

During the sampling time, the strobe pulses forward bias D5 and D6. By normal bridge function, the conduction of D5 and D6 charges or discharges C5, C6, C7 and C8. The voltage change on these capacitors changes about 2½% of the difference between the Feedback and DC Offset voltage and the incoming signal voltage. This voltage change, called the error signal, is amplified in the Preamplifier.

Preamplifier

The Preamplifier circuit (see Fig. 3-3) amplifies and time-stretches the error signal pulse from the Sampling Bridge, and AC couples it to the Post Amplifier in the sampling unit.

The input transistor Q31 operates as a very high input impedance high-gain inverting amplifier. Temperature compensation for Q31 is accomplished by thermister R33 in parallel with R34. The 4 mA current path is from the +50 volt supply through R31, Q31, the parallel combination of R33-R34 and R35 to the -50 volt supply. C34 assures that Q31 AC gain is high, while its DC gain is less than 1.

Q41 and Q45 are connected as an operational amplifier with a very low output impedance at Q45 emitter. The output is coupled by C49 and L49 to the 90 Ω input resistance Post Amplifier in the sampling unit. Q45 current

Circuit Description—Type S-1

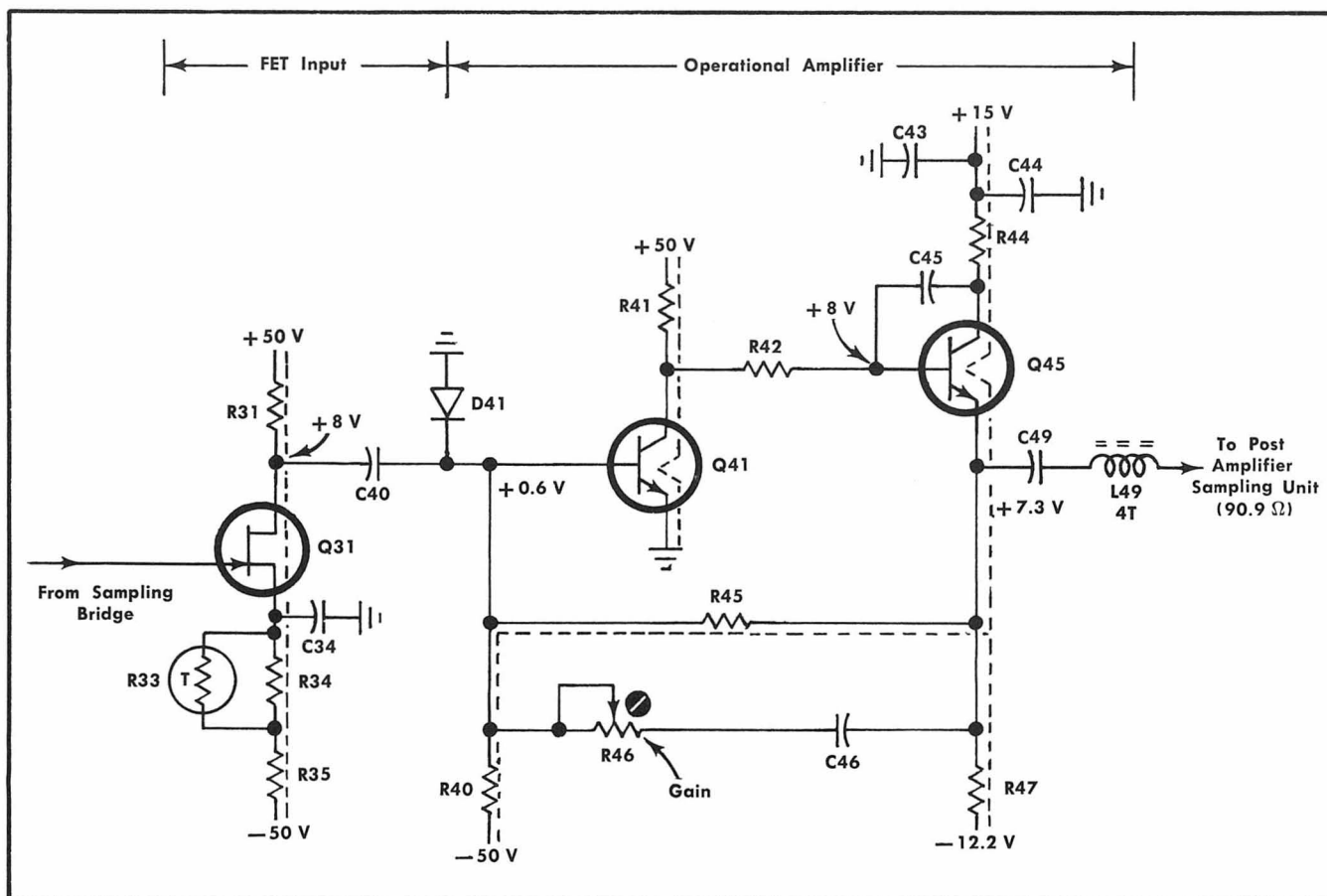

Fig. 3-3. Preamplifier circuit.

paths are shown by dashed lines in Fig. 3-3. D41 protects Q41 base from high negative voltage if Q45 is removed from its socket.

Current in R40 with DC negative feedback by R45 sets the output DC voltage level of the amplifier at about 7.3 volts. Negative AC feedback from the emitter of Q45 through C46 and Gain control R46 to Q41 base controls the AC gain of the Preamplifier. The Gain control R46 allows the AC feedback to be adjusted, thereby adjusting the gain. The AC gain of the Preamplifier is usually adjusted to be about 16 depending upon the sampling efficiency. For example: For an input signal into the Type S-1 input connector of 500 mV, if the display dot change is 100% of the signal, Q45 output signal will be about 200 mV. A positive 500 mV input signal will produce a +12.5 mV signal at Q31 gate (for a 2.5% sampling efficiency), and a positive 200 mV output signal. Likewise a negative input signal will produce a negative output signal.

Blow-by and Trigger Pickoff

The Blow-by and Trigger Pickoff circuits consists of Q13, Q17 and associated components connected as a common-emitter paraphase amplifier. See Fig. 3-4. The primary purpose of the circuit is to cancel unwanted high frequency capacitively-coupled signals that bypass the Sampling

Bridge. The secondary purpose is to provide a trigger pick-off signal to the sampling unit for external triggering of the sampling sweep unit.

Input signal to the Blow-by and Trigger Pickoff circuit is a portion of the Type S-1 input signal. The signal is fed to the base of Q13 through R3. R10 terminates the 50 Ω impedance of J3-P3 coaxial connector and assures no reflections back into the input circuit. The output from Q13 collector feeds an AC coupled signal to the output side of the Sampling Bridge, cancelling the blow-by signal. The output from Q17 collector feeds a DC coupled trigger take-off signal to the sampling unit trigger amplifier.

To trace the Blow-by signal path, a portion of the Type S-1 input signal is coupled to the base of Q13 and inverted at the collector of Q13. The inverted signal amplitude is adjusted by R13, the Transient Response control, and fed through R14 and C14 to the output side of the Sampling Bridge. This signal is out of phase with the input signal, cancelling the induced displacement current of the capacitance shunting the Sampling Bridge.

The trigger pickoff signal path starts with a portion of the input signal coupled from Q13 emitter to Q17 emitter to provide an in-phase signal at Q17 collector to the Trigger Amplifier and selector circuits in the sampling unit. Q17 collector load is provided in the sampling unit.

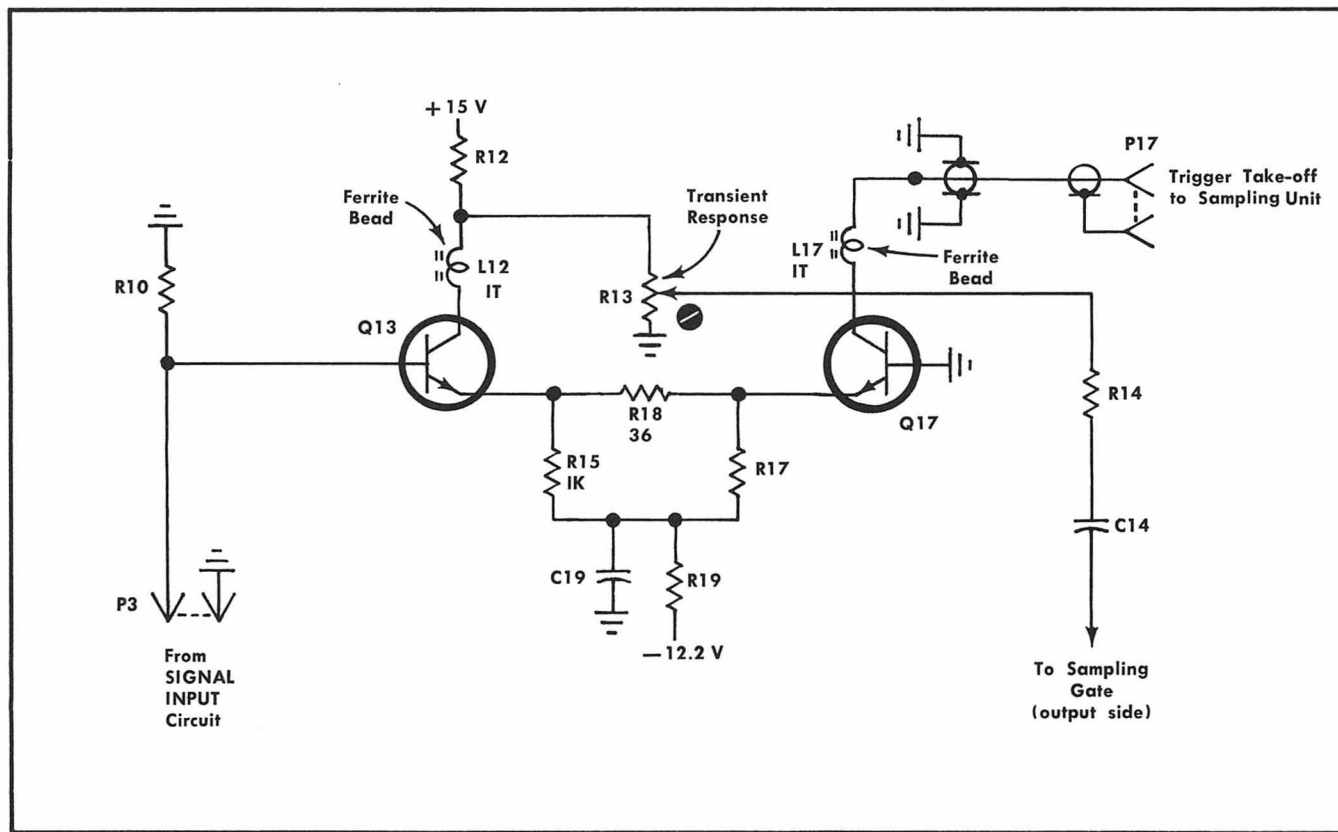

Fig. 3-4. Blow-by and Trigger Pickoff circuits.

SECTION 4

MAINTENANCE

Change information, if any, affecting this section will be found at the rear of the manual.

Introduction

This section of the manual contains information for use in corrective maintenance or troubleshooting of the Type S-1.

To remove the Type S-1 from its case, loosen the four retaining screws on the back. Then slide the back off, and remove the body by sliding it to the rear. Directions for replacing the case on the sampling head will be found at the end of this section.

Parts Replacement

All parts used in the Type S-1 can be purchased directly through your Tektronix Field Office or Representative. However, replacements for standard electronic items can generally be obtained locally in less time than is required to obtain them from Tektronix. Replacements for the special parts used in the assembly of the Type S-1 should be ordered from Tektronix since these parts are either manufactured or selected by Tektronix to satisfy a particular requirement. Before purchasing or ordering, consult the Electrical or Mechanical Parts List to determine the value, tolerance and ratings required.

NOTE

When selecting the replacement parts, it is important to remember that the physical size and shape

of a component may affect its performance at high frequencies. Parts orientation and lead dress should duplicate those of the original part since many of the components are mounted in a particular way to reduce or control stray capacitance and inductance. After repair, the sampling head may require recalibration.

Transistor Replacement. Cut the leads of a replacement transistor to the same length as the transistor removed and bend the leads as necessary. The lead configurations of the transistors used in the Type S-1 are shown in Fig. 4-1. Two transistors, Q13 and Q17, have soldered leads and are soldered to the circuit board. The field-effect transistor mounting has an arrow at the top position.

Leadless Capacitors. There are leadless ceramic capacitors soldered directly to the circuit boards. Care must be taken when replacing these capacitors as they are easy to crack. The type of solder used must be high quality, with good cold-flow characteristics. Thus, do not use 50/50 solder, but 60/40 or 62/38 solder when replacing the leadless capacitors.

Best results will be obtained by applying heat from the soldering iron directly under the leadless capacitor on the opposite side of the board. Usually a plated-through hole is under the leadless capacitor, allowing solder to conduct heat through the board. Without plated-through holes, the

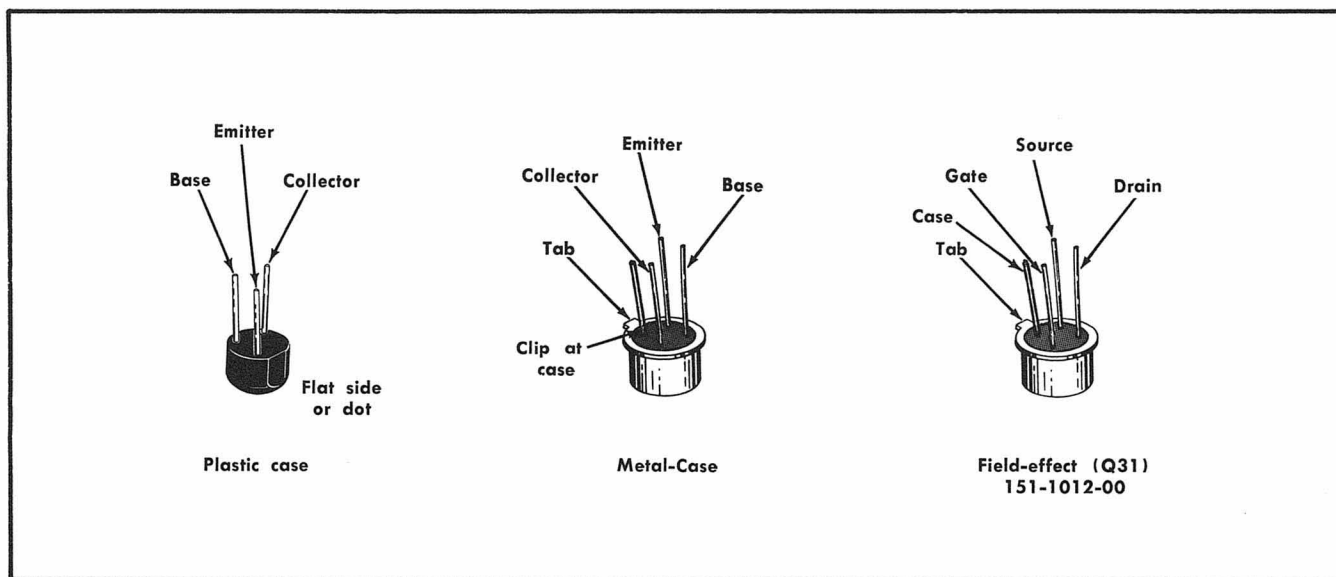

Fig. 4-1. Lead configuration for board-mounted transistors.

Maintenance—Type S-1

capacitor may be soldered into place by positioning the part, then applying heat to the adjacent plated area.

Use only enough solder to obtain a good full-flow joint. Excess solder on either side of the capacitor can lead to a shorted circuit.

Removal and Replacement of Snap-off Diode. The Snap-off diode is mounted in small metal clips, as shown on the circuit board illustration. The diode is best removed or replaced with a pair of shaped plastic tweezers, such as Tektronix Part No. 006-0765-00, or equivalent.

Replacement of Sampling Bridge Diodes. The Sampling Bridge diodes may be removed or replaced on the Sampler Board through the top of the unit. Fig. 4-2 shows a method for the removal or replacement of the white plastic holder in which the diodes are mounted.

CAUTION

The diodes are very fragile and it is possible to break one or both if the white plastic holder is removed or replaced too rapidly. Damage is caused when the holder ends snap together as they are moved from the circuit board. (Above SN B0104515 the diodes are soldered in place.)

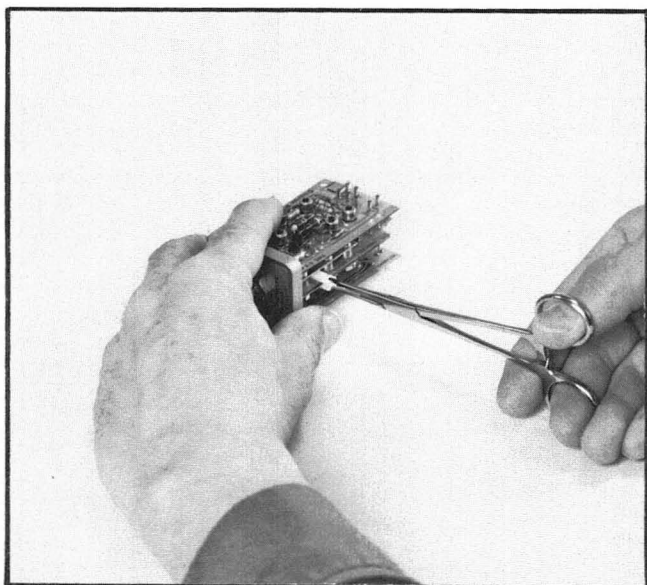

Fig. 4-2. Removal or replacement of sampling bridge diodes.

The position of the plastic diode holder assembly is shown in Fig. 4-3 with the shields removed; it is not necessary to remove these shields to replace the sampling diode assembly. For removal or replacement use Xcelite Forceps 42H, or similar tool.

The hook-like ends of the diode holder normally rest in a circuit board hole and firmly hold the diodes to the plated area. Cautious removal, especially just as the holder clears the circuit board, is necessary to minimize the physical shock and possible damage to the diodes, as the hook-like

ends may snap or spring together. Replacement of the holder should also be by slow, cautious movement; first as the hook-like ends reach the plated area which increases the thickness and second as they reach the hole where the possibility of physical shock exists as in the removal. A metal shield prevents the holder being inserted too far.

Circuit Board Replacement. If a circuit board is damaged and cannot be repaired, the entire assembly including all soldered-on components should be replaced. The part number given in the Mechanical Parts List is for the completely wired board.

The Preamp Board and the Strobe Board are removed by gently pulling outward from the Sampler Board. To replace the boards, align the connectors and pin contacts and ease the boards into position. Pin connectors should not protrude beyond the clamps.

The Sampler Board is removed as follows:

1. Remove both the Preamp Board and the Strobe Board.
2. Remove the 12 sided nut (nutdriver, special, Tektronix Part No. 003-0459-00) which secures the GR connector to the front panel.
3. Slide the Sampler Board and the GR connector away from the front panel.

To remove the Shields and Input Connector:

1. Loosen the threaded nut by turning it counterclockwise with the special Tektronix tool, Part No. 003-0607-00. Do not remove the threaded nut, but back it off just enough to free the notched plate (see Fig. 4-4).
2. Rotate the notched plate 90° and slide the Input Connector assembly away from the circuit board.
3. Loosen, but do not remove, the seven nuts holding the shields.
4. Remove the 7 nuts and bolts, freeing the shields.

TROUBLESHOOTING

The design of this sampling head is such that printed circuit boards are interchangeable from one unit to another. Since the outer boards are easily removed and replaced, it is possible to quickly troubleshoot a faulty sampling head by interchanging boards with an operating one. Thus, removal of the preamp board from the operating unit and replacement with one from the defective unit quickly checks the faulty units' preamp circuits.

The sampler board may be checked for defective parts without disassembly by the following procedure:

1. Remove the sampling diode plastic holder.
2. Remove the Preamp board. Leave the Strobe board in place.
3. With an ohmmeter, check the DC resistance to ground from the preamp input pins H and I. If a direct short is found, C5 or C6 is shorted; if a 350 Ω connection to ground is found, then C7 or C8 is shorted.
4. To check C5, C6, C7 and C8 for opens, (with Preamp board removed), use a Tektronix Type 130 Direct-Reading L-C

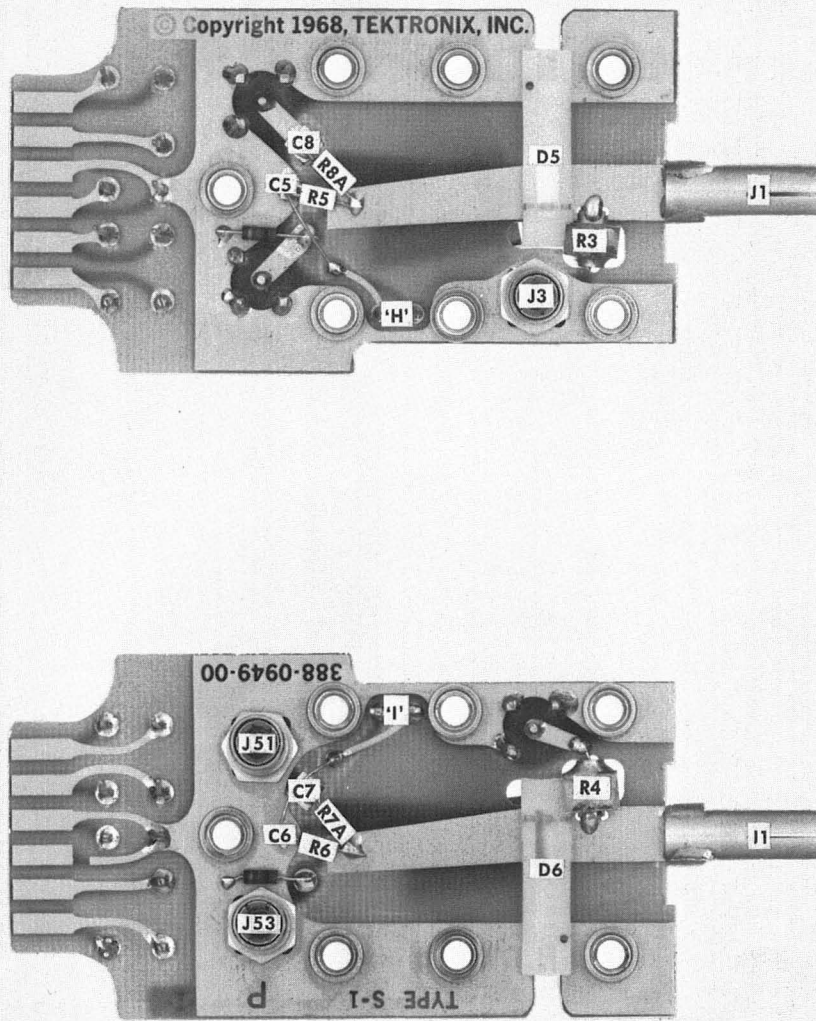

Fig. 4-3. Sampler circuit board, shields removed.

Maintenance—Type S-1

Meter (or equivalent) and refer to Table 4-1 for the values of capacitance from either pin H or I to ground.

TABLE 4-1

Input C	Problem
25 pF	Capacitors OK
20 pF	C5 (C6) open
10 pF	C7 (C8) open
5 pF	C5 and C7 open (C6 and C8)

Attempt to isolate trouble to one circuit through operational and visual checks. Verify that the trouble is actually a malfunction within the Type S-1, and not improper adjustments or malfunctioning associated equipment. Note the effect the adjustments have on the trouble symptoms. Normal and abnormal operation of each adjustment helps establish the location and nature of the trouble.

Check the instrument calibration procedure given in Section 5, and note the position of each adjustment so it can be returned to its original position after the check. This will facilitate recalibration after the trouble has been found and corrected.

Check the Circuit Diagram for voltages and waveforms. A block diagram and schematic diagram are included in Section 8 of this manual. It is usually best, if the trouble is not isolated to a circuit, to start with the power supplied from the sampling unit; see Table 4-2, then proceed consecutively from one circuit to the next.

TABLE 4-2

Test Point Pin		Power Supply (Decoupled)	Tolerance
Preamp Board	Strobe Board		
G	B	+50 V	± 1 V
A	A	+15 V	± 0.15 V
F	C	-50 V	± 0.5 V
B	—	-12.2 V	± 0.37 V

CAUTION

Use care when measuring voltages or signals. The small size and high density of components in this instrument establishes a condition such that an inadvertent movement of the test probe or the use of oversized probes may cause a short-circuit between components.

Major Circuit and Part Locations

The remainder of this section includes photographs of sections of the Type S-1. Major circuit areas are identified. All components mounted on circuit boards are identified by circuit numbers.

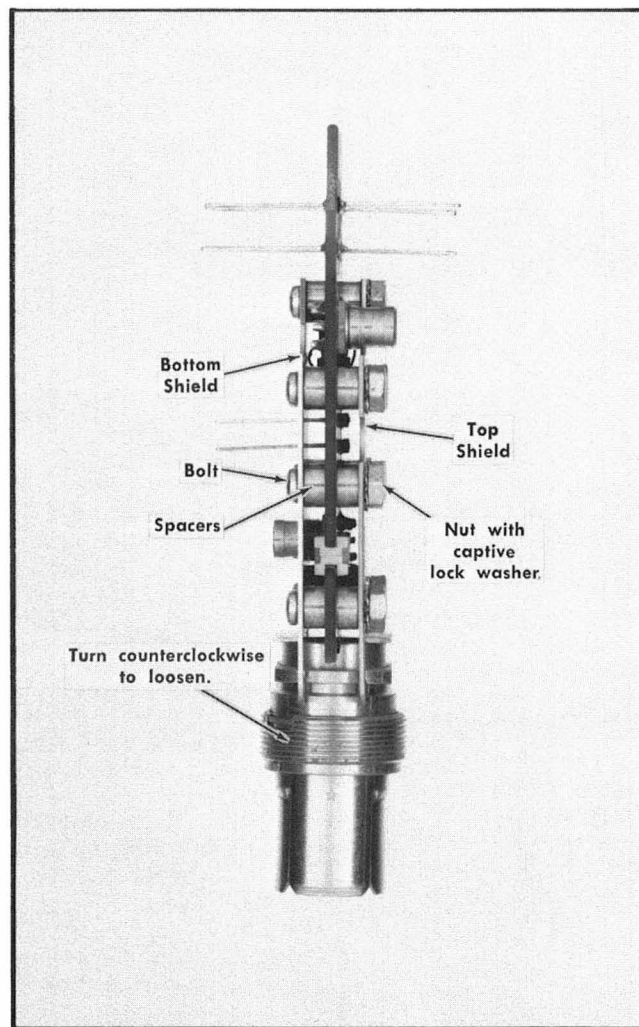
**Fig. 4-4. Assembly of Sampler Circuit board.****Replacing the Sampling Head Case**

To replace the case on the sampling head, align the body so that the hole in the side will appear over the Bridge Bal control at the rear of the Preamp board. Check that the upper and lower corners of the Preamp board and Gate Generator boards are aligned with the channels in the sampling head body which contain the zigzag springs. Push the body gently forward until it contacts the front panel. Be sure that the white plastic pawl on the locking knob is properly aligned as the sampling head unit is slid into the body. In attaching the rear castings, be sure that the hole at one side of the casting fits over the trigger pick-off signal output connector. Insert the four long mounting bolts and tighten them securely.

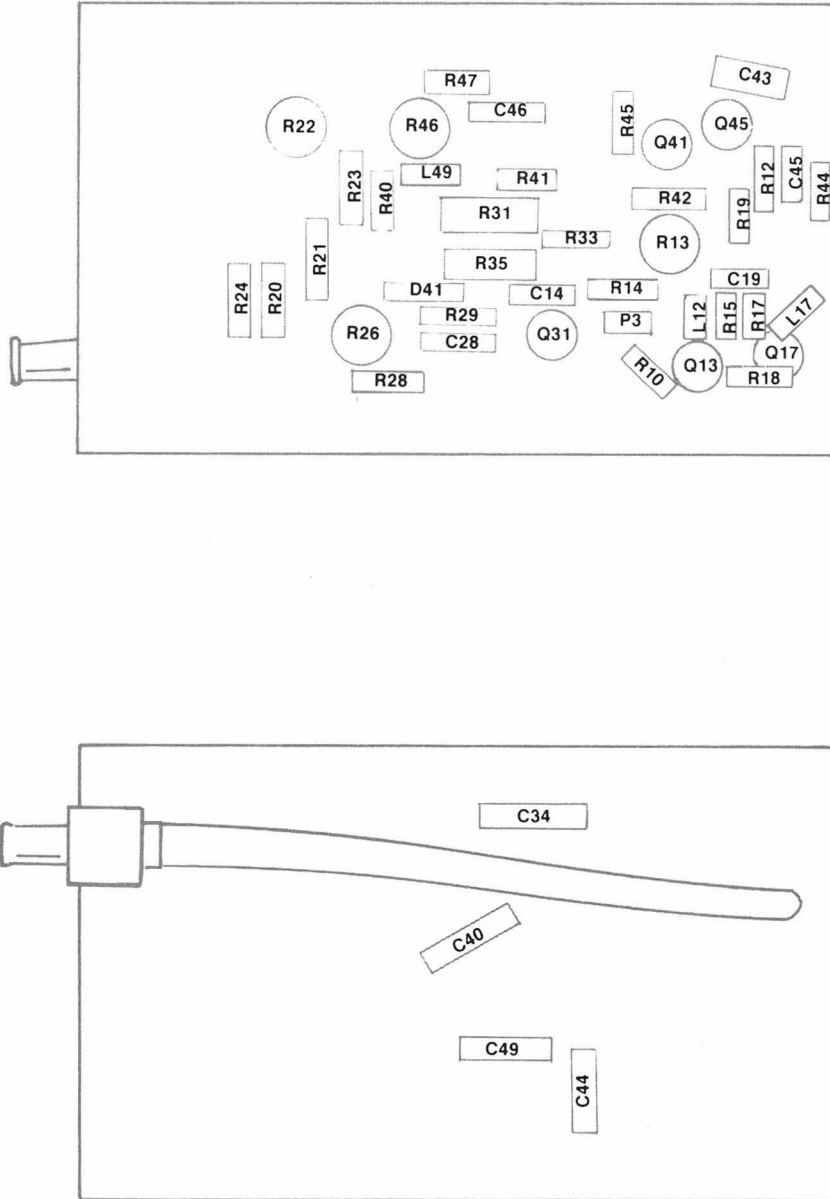

0763-01

Fig. 4-5. Preamp circuit board.

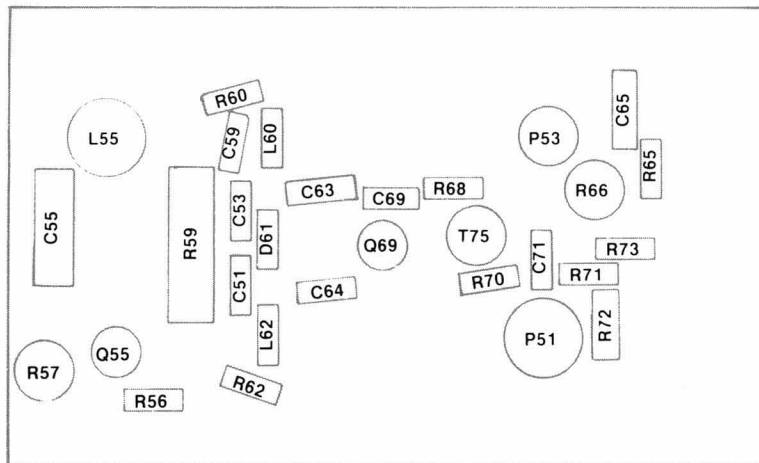

0763-02

Fig. 4-6A. Strobe Generator circuit board Eff. SN B010100-B069999.

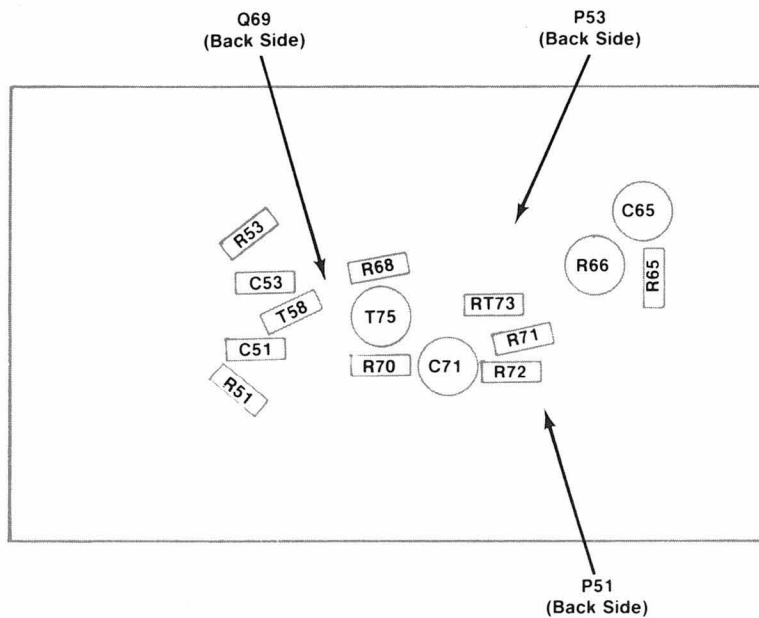

0763-03

Fig. 4-6B. Strobe Generator circuit board Eff. SN B070000-up.

SECTION 5

PERFORMANCE CHECK / RECALIBRATION

Change information, if any, affecting this section will be found at the rear of the manual.

Introduction

Performance of the sampling head can be checked without making internal adjustments by using the steps of this procedure whose headings are set in the type face used in step 1 (page 5-5). Failure to meet the requirements given in any check indicates the need for recalibration. Recalibration steps are headed by the type face shown in step 2.

The sampling head performance can be restored to the limits stated in Section 1 by performing the recalibration steps of this procedure. Any needed maintenance should be performed before proceeding with recalibration.

Since the sampling head functions as a part of the associated sampling unit, it is recommended that the performance checks for the sampling unit be performed just before these performance checks are made. Then, if the sampling unit requires recalibration, that procedure should be performed before starting this procedure.

EQUIPMENT REQUIRED

The equipment listed below or its equivalent is required for a complete check and recalibration of the Type S-1 Sampling Head; see Fig. 5-1. The equipment listed is used in the following procedure. Equipment specifications given are the minimum necessary for the particular use of each item. All test equipment must be correctly calibrated. If other equipment is substituted, it must meet or exceed the limits stated below. If a pulse generator other than the Type 284 is used, fast pulse display characteristics may vary from those shown in this manual.

All equipment items listed, except items 12, 13 and 14, can be obtained by ordering through your local Tektronix Field Engineer or Representative.

1. Test Oscilloscope. Bandwidth, DC to at least 50 MHz. Minimum deflection factor of 20 mV/div. For example, a Tektronix Type 585 with Type 82 Plug-In Unit.

2. 10 \times Probe for use with test oscilloscope. Tektronix P6008 Probe recommended with the Type 82 Plug-In Unit. Tektronix Part No. 010-0129-00.

3. Indicator Oscilloscope, with proper sampling plug-in units, such as a Type 561A or Type 564 Oscilloscope with Type 3S2 Sampling Unit and Type 3T2 Random Sampling

Sweep. Or, a Type 568 Oscilloscope with the same vertical and horizontal plug-ins, and Type 230 Digital Unit if the sampling system is used with digital readout.

4. Special 3 foot flexible extender cable for operating the sampling head outside the sampling unit. Tektronix Part No. 012-0124-00 required.

5. Signal Generator-Pulse Generator, such as the Tektronix Type 284 Pulse Generator used in this procedure. Pulse risetime ≤ 70 ps, at approximately 200 mV amplitude into 50 Ω , with a trigger signal available at least 75 ps in advance of the fast pulse. Square wave signals of 1 μ s period (1 MHz) and 100 ns period (10 MHz) at 1-volt amplitude into 50 Ω . (If your Type 284 Lead time switch is labeled 5 ns-50 ns, order modification kit, Tektronix Part No. 040-0487-01.)

6. 50 Ω coaxial cable, RG 58/U, 5 ns signal delay, with GR 874 connectors. Tektronix Part No. 017-0512-00.

7. 50 Ω coaxial cable, 5 ns signal delay, approximately 40 inches long, with BNC connectors. Tektronix Part No. 012-0057-01.

8. 50 Ω coaxial air line, 20 cm long, with GR 874 connectors. GR 874-L20. Tektronix Part No. 017-0084-00.

9. One 50 Ω 5 \times Coaxial Attenuator, such as GR 874-G14. Tektronix Part No. 017-0079-00.

10. One 50 Ω 2 \times Coaxial Attenuator, such as GR 874-G6. Tektronix Part No. 017-0080-00.

11. A special Variable Attenuator with GR 874 connectors. It consists of a 100 Ω potentiometer across the 50 Ω line, and does not have a guaranteed response. Tektronix Part No. 067-0511-00.

12. DC Bridge for measuring 50 Ω . Plus or minus 2 volts DC maximum across 50 Ω resistor. Accuracy, $\pm 0.2\%$ required (not shown).

13. Small insulated handle, $\frac{3}{32}$ inch bit screwdriver for adjusting screwdriver-adjust controls. (Not shown.)

14. An RMS reading line voltage meter, with a $\pm 3\%$ accuracy at the line voltage to which the indicator oscilloscope is connected. (Not shown.)

Performance Check/Recalibration—Type S-1

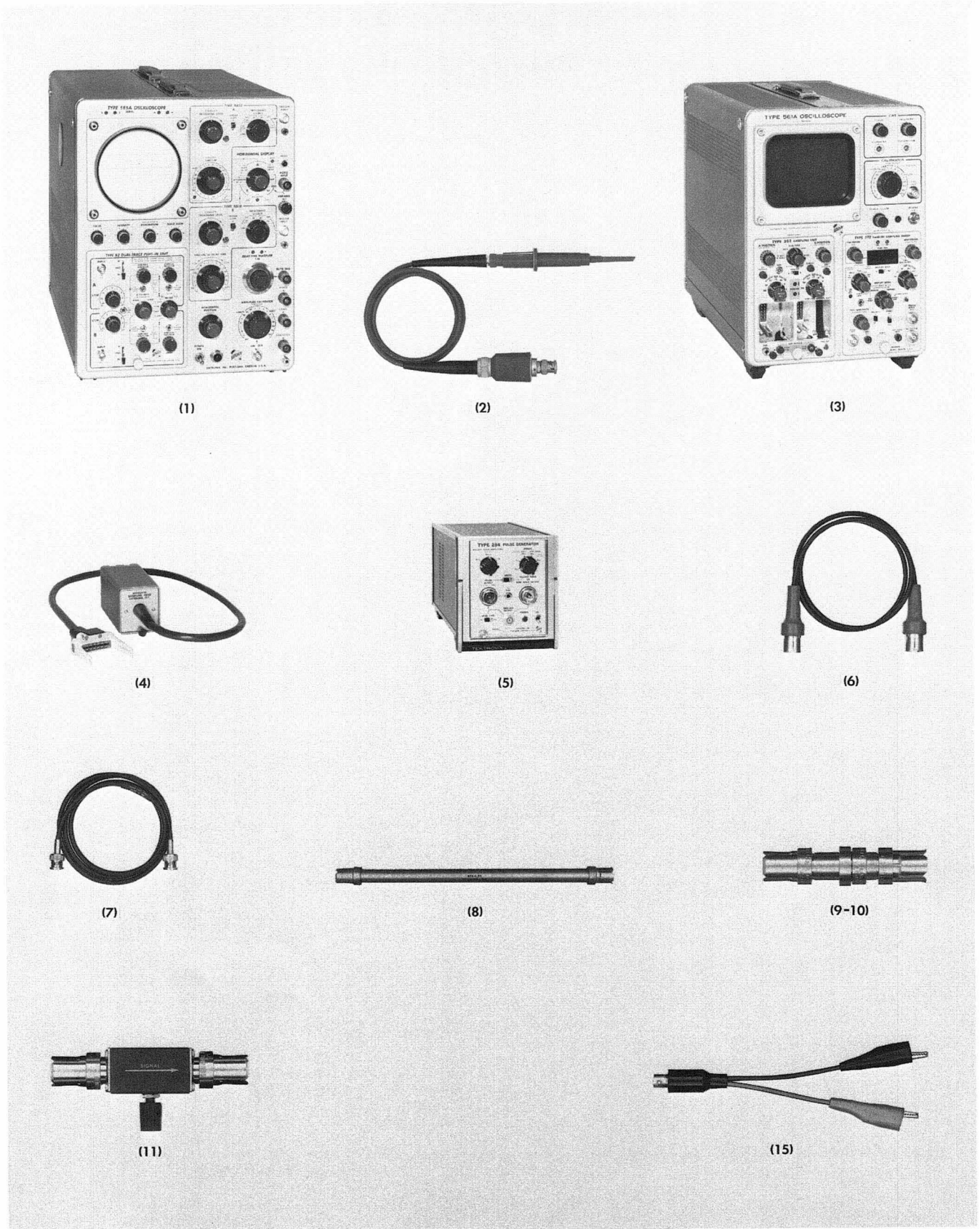

Fig. 5-1. Calibration Equipment.

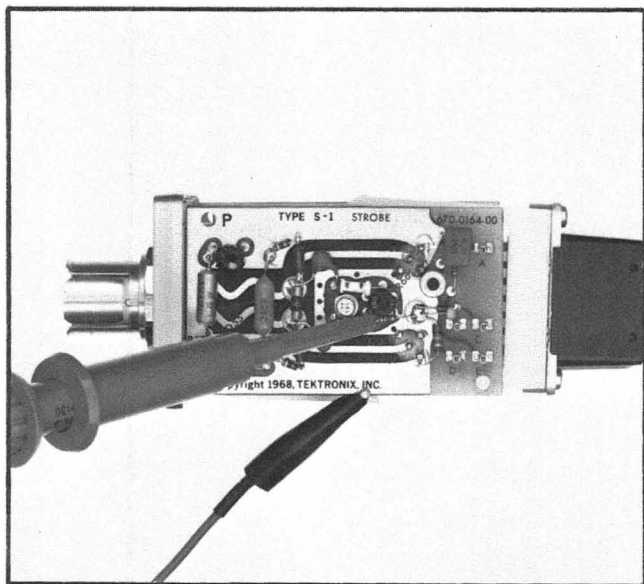

Fig. 5-2. Test oscilloscope 10 \times probe connected to Q69 emitter.

15. A clip lead to BNC adapter. Tektronix Part No. 013-0076-00.

PERFORMANCE CHECK AND RECALIBRATION RECORD AND INDEX

The following abridged procedure may be used as a guide by the experienced technician for checking and/or recalibrating the Type S-1 Sampling Head. The abridged procedure can be used as a maintenance record (the procedure may be reproduced without special permission of Tektronix, Inc.). The step numbers and titles are identical to those in the complete procedure.

Sampling Head Type S-1 Serial No. _____

Calibration Date _____

Calibrated By _____

Checked By _____

- | | | |
|--------------------------|---|-----------|
| <input type="checkbox"/> | 1. Check for Operation and Ability To Produce a CRT Display | Page 5-5 |
| <input type="checkbox"/> | 2. Check For Q69 (Avalanche) Operation | Page 5-5 |
| <input type="checkbox"/> | 3. Check 10% to 90% Risetime | Page 5-6 |
| <input type="checkbox"/> | 4. Adjust Risetime | Page 5-9 |
| <input type="checkbox"/> | 5. Check Loop Gain Linearity | Page 5-11 |

- | | | |
|--------------------------|---|-----------|
| <input type="checkbox"/> | 6. Preliminary Bridge Bal Adjust | Page 5-13 |
| <input type="checkbox"/> | 7. Adjust Transient Response (Blow-by) | Page 5-13 |
| <input type="checkbox"/> | 8. Check Pulse Flatness Deviation | Page 5-13 |
| <input type="checkbox"/> | 9. Check Trace Shift From 30 Hz to 50 kHz | Page 5-15 |
| <input type="checkbox"/> | 10. Final Bridge Bal Adjust | Page 5-15 |
| <input type="checkbox"/> | 11. Check Tangential Noise | Page 5-15 |

PRELIMINARY PROCEDURE

1. Check the sampling head 50 Ω DC input resistance. With the sampling head separated from the sampling unit, use a DC Resistance Bridge and measure the DC input resistance. Connect one lead to the input connector outer conductor, and the other lead to the center conductor. Be sure the bridge does not apply more than ± 2 volts to the input terminals.

The sampling head input resistance must be 50 Ω , $\pm 1\%$.

If the input resistance is high, examine the trigger pick-off resistance divider with an ohmmeter. R3 can be measured by removing the Preamp board from the head and measuring between the center pin of J3 and the center pin of J1. R10 can be measured from the center pin of P3 to ground. If either of these resistors is open, the sampling head DC input resistance will be out of tolerance on the high side.

If the input resistance is low, and if the voltage applied by the bridge exceeds 0.6 volt, check for a shorted capacitor among C5, C6, C7 and C8. If changing the input polarity from the DC bridge produces a proper resistance reading, the conduction path can be traced through the one sampling diode that does conduct, to help locate the defective part.

If the termination resistor is itself out of tolerance, it is recommended that the sampler board be returned to Tektronix for repairs. The resistor assembly (R4, R3 and the ground clip) is available for making repairs at the time of recalibration. If replacement is attempted, it is very important that no solder be permitted to flow onto the area of sampling diode contact.

Complete any needed repairs to the sampling head before proceeding.

2. Connect the sampling head and oscilloscope system. This step discusses the assembling of testing equipment, 5-minute warmup period, and setting of the vertical and horizontal plug-in unit Gain controls.

a. Assemble the indicator oscilloscope system. Place the Type 3S2 (or other Sampling Unit) into the left compartment of the indicator oscilloscope, and the Type 3T2 (or other Sampling Sweep Unit) into the right compartment. Install an operating sampling head into the Type 3S2 Channel B compartment. Leave the Channel A compartment vacant. (If using a Digital Readout unit, make the interconnections to the indicator.)

Performance Check/Recalibration—Type S-1

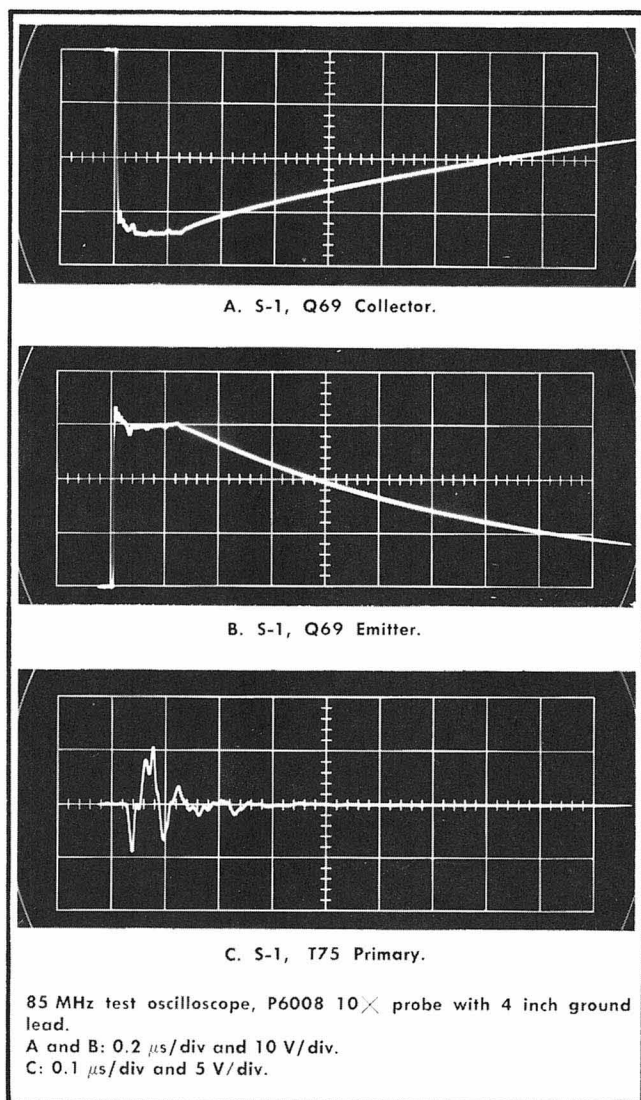

Fig. 5-3. Checking Avalanche drive and output.

b. Connect the RMS line-voltage meter to the power mains. Determine that the oscilloscope (and other equipment) power supply is set for the correct value of line voltage. Connect all the equipment to the proper power outlet and turn on the power. Obtain a free-running trace and let the equipment warm up for five minutes.

c. After the warm-up period, adjust the indicator oscilloscope Trace Alignment control so the free-run trace is parallel to the graticule lines.

NOTE

It is recommended that the recalibration procedure in the sampling unit instruction manual be completed before proceeding.

d. Connect the Type 284 Square Wave Output connector to the Channel B sampling head input. Use a 5 ns signal delay 50 Ω coaxial cable with GR 874 connectors (item 6 of equipment required). Connect the Type 284 Trigger Output

connector to the sampling sweep unit External Trigger input (50 Ω) connector. Use a 5 ns signal delay 50 Ω coaxial cable with BNC connectors (item 7 of equipment required).

Adjust both the vertical and the horizontal unit Gain controls for proper deflection factor of each unit. Use the Type 284 100 ns period square wave as both a time and amplitude reference.

e. Install the sampling head to be recalibrated onto the special three foot extender cable (item 4 of equipment required). Connect the other end of the cable into the Type 3S2 Channel A sampling head compartment. (The sampling head should be in its case.) Allow a five minute warm up of the system.

CHECK AND RECAL PROCEDURE**1. Check For Operation and Ability to Produce a CRT Display**

a. Connect the Type 284 Square Wave Output signal to the head to be calibrated. Then set the Type 3S2 controls for a Channel A display. If there is a square wave display, proceed to Step 3. If there is no square wave display, do Step 2.

2. Check For Q69 (Avalanche) Operation

a. Remove the extender cable from the sampling head (the indicator oscilloscope power may be left on).

b. Remove the sampling head case. First, remove the four round-head screws visible at the back of the unit; then slide the cover off by gently pulling it away from the front casing and input connector.

c. Reconnect the extender cable to the rear of the sampling head, being certain that the trigger pickoff coaxial connector mates with the coaxial connector of the extender cable. Use the signal set-up of step 1.

d. Use the test oscilloscope with 10 \times Probe to check for proper operation of Q69. The probe connections are shown in Fig. 5-2, and the general nature of the signals is shown in Fig. 5-3. Fig. 5-3A and B show the general amplitude for Q69 collector and emitter signals in the Sampling Head. Fig. 5-3C shows the typical drive signal at T75 primary (square terminal E) while the head is on the extender cable.

If T75 is receiving drive, but there is no signal out of Q69, change Q69 (changing Q69 may significantly increase the displayed noise, so it is best to have several transistors of this type on hand and grade them for low noise using step 11). If all signals of Fig. 5-3 are present, check the Preamplifier output (square terminal D). If there is no signal at the Preamplifier output, check the sampling diodes and Q31 in the following manner.

(1) Pull Q41 from its socket. Set the Type 3S2 DC Offset control for zero volts at the front panel Offset jack. Free run the time base unit. Use the test oscilloscope, with 10 \times probe, and monitor the drain lead of Q31.

(2) Q31 will have a pulse signal at each strobe time if the transistor is operating. If there is no pulse signal, change Q31, reinstall Q41 and try to obtain a trace.

Performance Check/Recalibration—Type S-1

(3) If Q31 is operating, and if there is a pulse of either polarity at its drain lead (with Q41 out), operate the BRIDGE BAL control (R22) through its range. As R22 is changed, the pulse signal should reduce to zero and change to the opposite polarity. If the pulse signals does not change polarity, one of the sampling diodes is open.

NOTE

The sampling diodes are very fragile and replacements are expensive. The white plastic clip should not be disturbed nor withdrawn unless you are certain that a diode is defective. If a diode is to be changed, reinsert the clip very carefully so that the diodes do not receive any physical shock as the clip ends drop into place. With extreme caution, it is possible to remove and replace a set of sampling diodes without damage.

(4) Restore Q41 to its socket. Once a display is obtained, go on to Step 4.

3. Check 10% to 90% Risetime

NOTE

This step follows Step 1, and is to be performed with the case on the sampling head. If Step 2 was performed, ignore this step and proceed to step 4.

Requirement—10% to 90% risetime is equal to or less than 350 ps.

a. Connect the equipment shown in Fig. 5-4. The extender cable is recommended, although not required. The cable permits easy access to the Type 284 TD Bias screwdriver control which is adjusted as part of this step.

Connections in Fig. 5-4 are:

(1) 20 cm 50 Ω air line between Type 284 Pulse Output connector and sampling head input connector. (No substitute signal cable is acceptable.)

(2) 5 ns signal delay 50 Ω coaxial cable (RG-58/CU, with BNC connectors between Type 284 Trigger Output jack and the sampling sweep unit External Trigger (50 Ω) input connector.

(3) Special 3 foot sampling head extender cable between the head and the Type 3S2 left side compartment connectors.

(4) If using digital readout, the proper cable between the oscilloscope and the digital unit, supplied with the Type 230.

NOTE

Instrument risetime can be checked either by visual measurement of the CRT display, or by a digital readout unit. Digital measurement of rise-

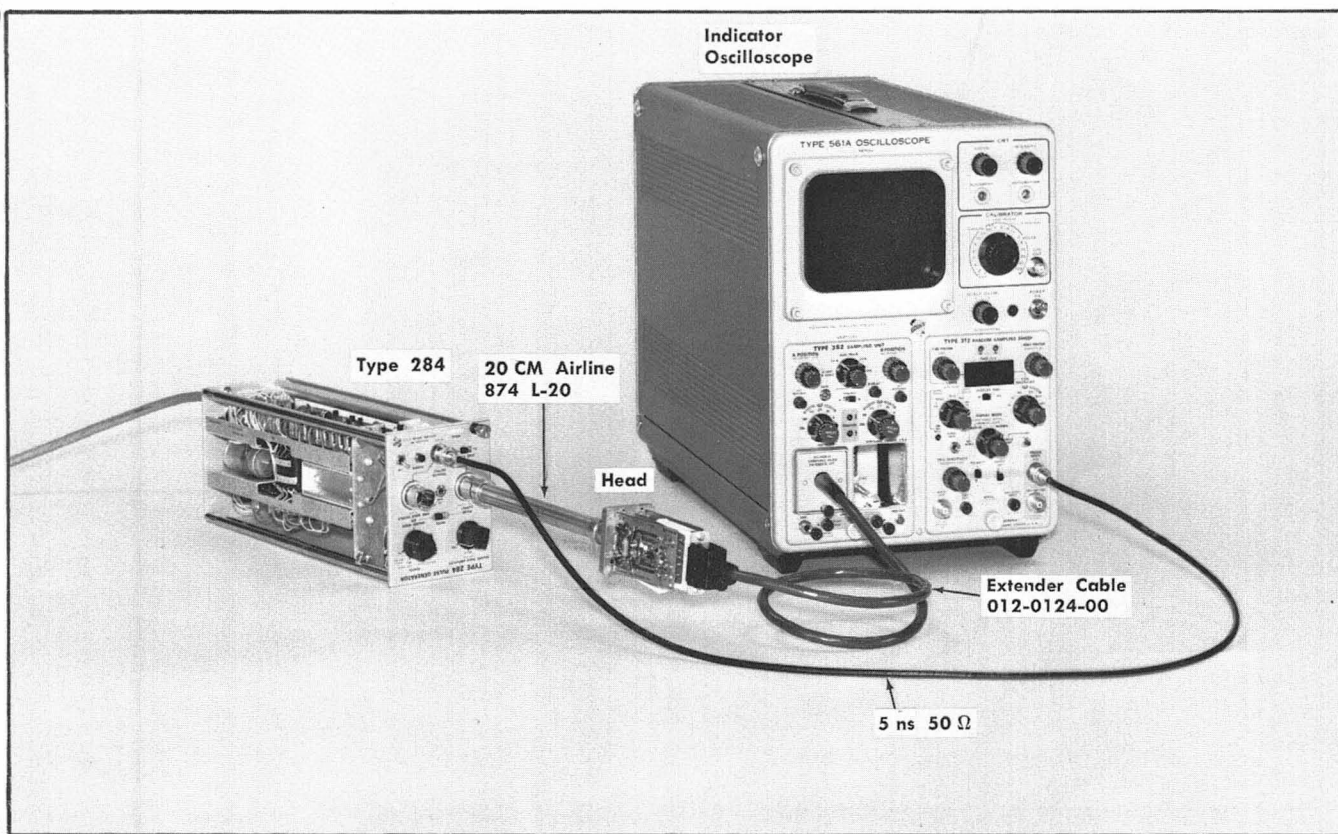

Fig. 5-4. Risetime check test equipment set-up.

Performance Check/Recalibration—Type S-1

time requires that the Type 3T2 be operated in the With Trigger mode. With Trigger operation requires that the Type 284 trigger pulse have a leadtime of at least 73 ns before the fast Pulse Output signal. (Type 284 instruments with only 5 ns-50 ns Lead Time required the installation of Field Modification Kit, Tektronix Part No. 040-0487-01.)

CRT risetime measurement permits the Type 3T2 to operate in the Before Trigger (Random) mode, in which the trigger leadtime does not have to be 73 ns.

The 73 ns stated here is required for the With Trigger mode when the sampling head is operating on a 3 foot extender cable and the trigger cable has a 5 ns signal delay. Less leadtime (about 70 ns) is required when the sampling head is installed in the Type 3S2 and the trigger cable signal delay is only 2 ns.

Fig. 5-5 shows a substitute method of obtaining 73 ns trigger leadtime in an early model Type 284. If you install the recommended 23 ns signal delay cable shown in Fig. 5-5, operate the Type 284

with the case removed and adjust it as described in the following portions of this step. Most Type 284 Pulse Generators include 75 ns trigger signal lead time.

Digital Readout of Risetime

Set the controls as follows:

Type 284

Mode	Pulse Output
Leadtime	75 ns
Other controls	Optional

Type 3S2

Normal-Smooth	Normal
Units/div	50
Variable	CAL
Mode	Channel A
Trig Out	Optional
Dot Response	Midrange
Other Controls	Optional

Type 3T2

Time Position	Fully clockwise
Fine	Midrange for centered display
Range	100 ns
Time Magnifier	$\times 50$ } 200 ps/div
Variable	Cal
Display Mag	$\times 1$
Start Point	With Trigger
Display Mode	Normal
Trigger Source	Ext
Trigger Polarity	+
Trigger Sensitivity	10 o'clock
Recovery Time	Optional
Internal Samples/Div	100

Indicator Oscilloscope

Intensity	Normal display
Scale Illum	As desired

Type 230

Measurement Averaging	8
CRT Intensification	Both Ref Zones and Time Measurement on
Measurement Mode	Time
CH A Reference Zones	Both at Average
Channel Switches	Both at A
Time Measurement Start Point	10% Between Zones
Time Measurement Stop Point	90% Between Zones
Slope	Both at +1st
Display Time	Midrange
Triggered Measurement Limits	Off
	Optional

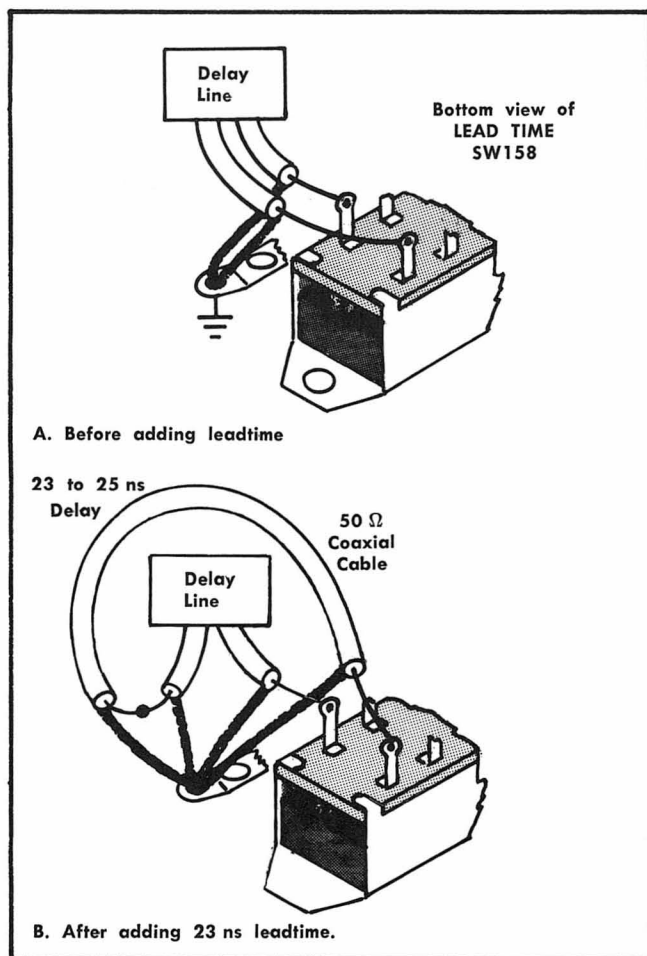

Fig. 5-5. Adding leadtime to a Tektronix Type 284 Pulse Generator, before SN_____.

b. Use the Type 3T2 Fine Time Position control to position the pulse rise as in Fig. 5-6A.

If a pulse display cannot be positioned into view, turn the Time Position to midrange (pulse display is off the CRT to the left) and adjust the Type 284 TD Bias control. Start by turning the TD Bias control fully counterclockwise. This assures that there is no pulse output and the indicator oscilloscope trace should be positioned two divisions up from the lower edge of the graticule. Slowly turn the Type 284 TD Bias control clockwise to a midrange position that causes the indicator oscilloscope trace to jump up about 5 divisions. (Repeat, so the control is at a position that just causes the trace to be up.) Set the Type 3T2 Time Position controls fully clockwise. If the indicator oscilloscope trace remains up 5 divisions without displaying a positive pulse, there is not sufficient leadtime in the triggering signal path. Shorten the 5 ns signal delay cable to the Type 3T2 Ext Trig 50 Ω input connector to 2 ns signal delay, and try again. Or operate in Channel B and use the B Delay control to gain more display leadtime. (An additional 2 ns trigger leadtime can be obtained by clockwise rotation of the Type 284 Snap Current control, R174, but at a cost of slowing the rate of rise of the fast Pulse Output signal. The recommended setting of R174 is about 30° from the counterclockwise stop, and at a position where the displayed pulse time jitter is the least. Adjusting R174 for least trigger jitter (near its counterclockwise end) usually speeds the fast Pulse Output so the pulse risetime is about 45 to 50 ps.

c. Once a pulse display is obtained, position it and the digital 0% and 100% zones as shown in Fig. 5-6A. Read the risetime from the Digital unit. With the Type 3T2 Time Magnifier at $\times 50$ for 200 ps sweep rate, 350 ps will be read as $+0.350$ ns, and 75 ps will be read as $+0.075$ ns.

If the risetime is 350 ps or less, proceed to Step 5.

If the risetime of the sampling head is too slow, perform Step 4.

CRT Measurement of Risetime

Set the Type 3T2 controls:

Internal Samples/Div	Variable
Front Panel Samples/Div	9 o'clock
Start Point	Before Trigger
Trig Sensitivity	Clockwise to free run until a trace appears (several seconds), then back to 10 o'clock area for least trigger jitter.
Time Position	Counterclockwise until step pulse appears.

The Type S-1 risetime can be measured at 200 ps/div sweep rate with the Type 3T2 Range and Time Magnifier controls as set in the digital readout setup.

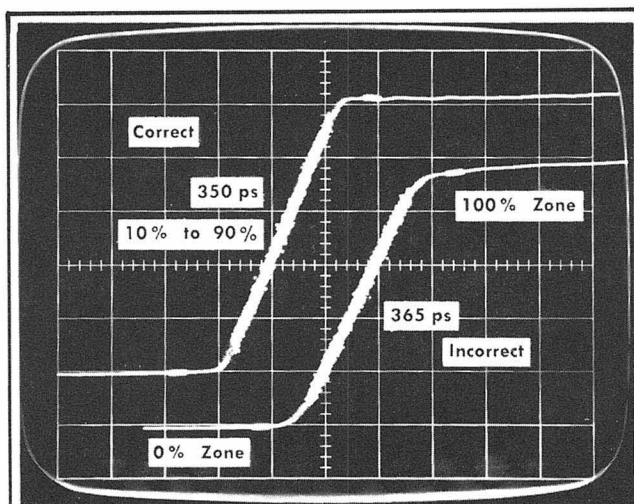

A. S-1. Digital risetime checks.

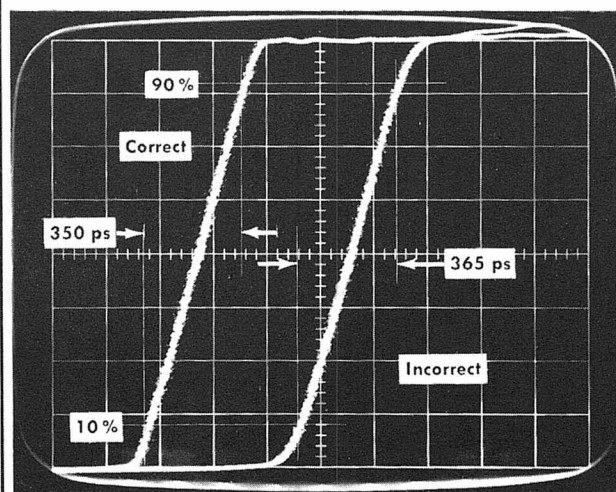

B. S-1, CRT-measured risetime checks.

A is taken using Type 568 and Type 230 Digital Unit.
B is taken using a Type 561A.
A and B: 200 ps/div, Type 3T2 in With Trigger mode.
A: Type 3T2 internal Samples/Div switch at 100.
B: Type 3T2 internal Samples/Div switch at Variable.

Fig. 5-6. Sampling Head risetime check displays. Left is correct. Right is slow due to clockwise rotation of Avalanche Volts control.

Use the Type 3S2 Units/Div Variable control to obtain an 8 division vertical display.

Most accurate risetime measurement from the CRT is made by taking a photograph. Scribe the photo in a manner similar to that done in Fig. 5-6B.

If the risetime is 350 ps or less, proceed to Step 5.

If the risetime of the sampling head is too slow, perform Step 4.

Performance Check/Recalibration—Type S-1

4. Adjust Risetime

a. Each internal control has its particular effect upon sampling head operation. The list below gives the general effect of each control.

Control	Function
Avalanche Volts, R66	Alters strobe pulse amplitude and risetime, which affects the display risetime and dot response. Clockwise rotation makes risetime slower.
Snap-Off Current, R57	Alters loop gain and display noise. Must be adjusted any time Avalanche Volts is changed.
Gain, R46	Alters loop gain.
Bridge Volts, R26	Sets sampling diodes reverse voltage. Decreasing the bridge volts (counterclockwise rotation) slows display rise time by permitting a longer diode conduction time due to fixed amplitude strobe pulses. Keeping the Bridge Volts near maximum (clockwise) allows better sampling dot response linearity as well as a larger input signal dynamic range.
Bridge Bal, R22	Introduces an internal offset voltage to the feedback loop to cancel normal error signals in the sampling loop, including normal unbalance in the sampling bridge. R22 is adjusted (with DC Offset at zero) to cancel most of the trace vertical shift as the Units/Div switch position is changed.
Transient Response, R13	Adjust the magnitude of blow-by correction signal. (Not important when setting risetime.)

NOTE

It is usually possible to achieve a risetime value less than that quoted in Section 1. The faster risetime is possible while also meeting the other specifications of noise and pulse flatness deviation. A single CRT measurement of risetime is usually adequate to check for proper sampling operation. An exact figure of the system (pulser, coaxial cable, and sampling head system) risetime can be more easily obtained by use of a digital readout unit. The digital readout figure can be accepted as the disetime of the Type S-1 itself if the

Pulser used is as fast as the Type 284. The procedure below is not specifically limited to use with either form of risetime measurement; therefore, if you use a digital system, set the digital unit controls as listed in Step 3. Risetime adjustment is given as the first recalibration step, because any time the Avalanche Volts control setting is changed, it is necessary to also adjust R57, R46 and R22 in that order.

b. Remove the sampling head cover. The head must be on an extender cable for access to all controls. Make the connections shown in Fig. 5-4. Set the controls as in Step 3. Preset the sampling head internal controls (see Fig. 5-7).

BRIDGE VOLTS Fully Clockwise
GAIN 30° from clockwise end

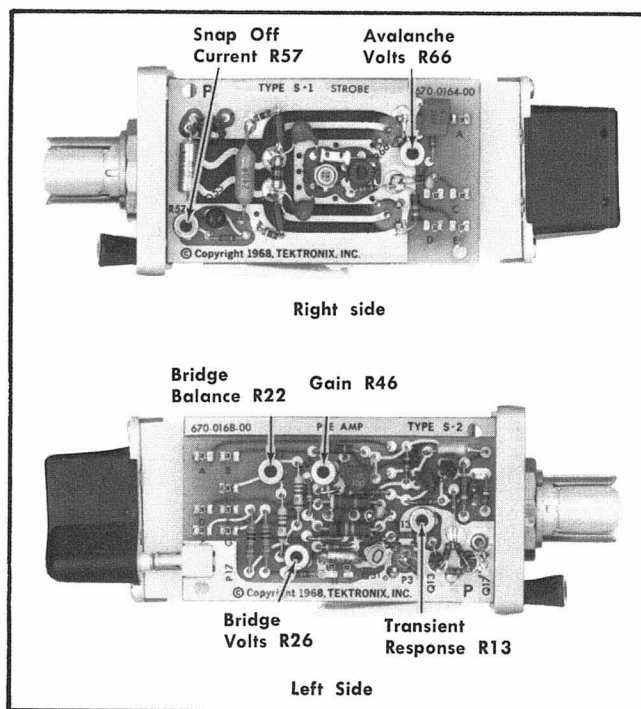

Fig. 5-7. Sampling head control locations.

Leave the other head controls as previously adjusted.

c. Operate the Type 3T2 with the Start Point switch at With Trigger. Obtain a display of the pulse rise.

Assuming that the risetime is slow, adjust the Avalanche Volts control about 5° counterclockwise. Fig. 5-8B shows a triple exposure of the effects of changing the setting of the AVALANCHE VOLTS control. Both the vertical and horizontal changes were caused by the AVALANCHE VOLTS control only; the vertical and horizontal Position controls were not touched.

Check the risetime, and do (d.) below. Then continue to adjust the AVALANCHE VOLTS control until the risetime is 350 ps or less, 10% to 90%. Repeat (d.) again.

d. Operate the Type 3T2 with the Start Point switch at Before Trigger. Obtain a display of the pulse rise.

Adjust the SNAP-OFF CURRENT control to maximize loop gain. This is done by first using the Type 3S2 Dot Response control to determine whether the display dot response shows more than or less than unity loop gain. If it is less than unity, adjust the SNAP-OFF CURRENT control to reduce the trace vertical spread. If the loop gain is more than unity, adjust the SNAP-OFF CURRENT control to increase the trace vertical spread. (See Fig. 5-8A.)

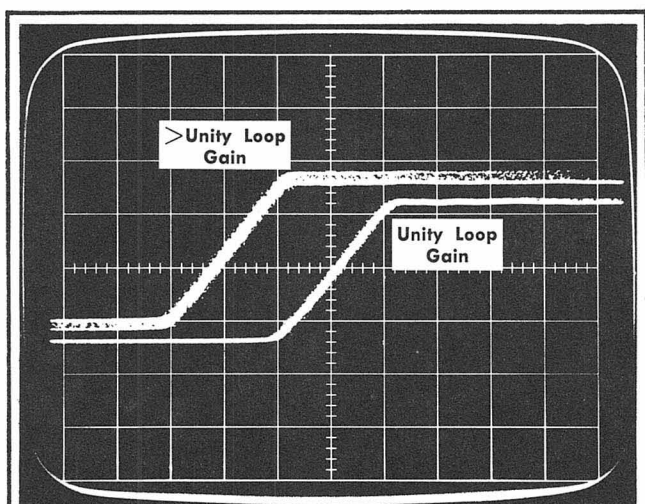

A. Dot response check.

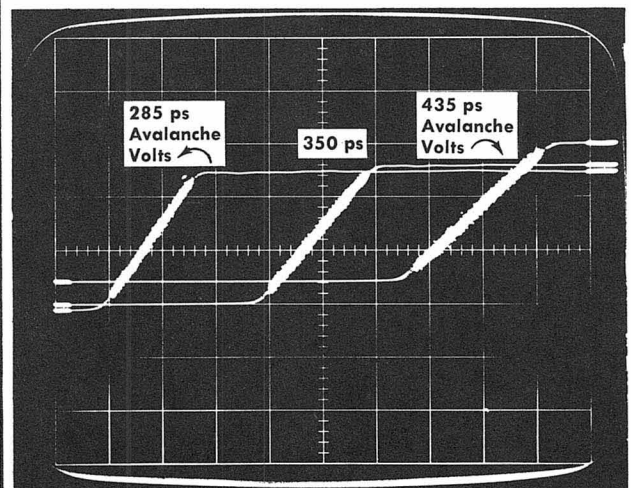

B. Changes in display for 3 positions of Avalanche Volts control.

Fig. 5-8. Type S-1 displays for step 4. Sweep rate: 200 ps/div.

NOTE

The Type S-1 will in some cases have less display noise when adjusted for a risetime faster than 350 ps. The practical adjustment limit lies within the range of both the SNAP-OFF CURRENT and the GAIN controls. If the AVALANCHE VOLTS control is adjusted for too fast a risetime, one or both

of the other controls will reach the end of its adjustment range and prevent proper calibration.

As the SNAP-OFF CURRENT control is turned, the display will move. The display shift is in the form of a rising or a dipping arc. The vertical component of the display movement is a result of a change in SNAP-OFF CURRENT, rather than any signal input change. The peak of the arc in either the positive or the negative direction occurs very near the point at which maximum loop gain occurs. Set the SNAP OFF CURRENT control to the point where the display is at the peak of the arc, rather than precisely at maximum loop gain. This produces minimum display noise with proper risetime.

e. Set the Type 3S2 Dot Response control to its electrical midpoint. The electrical midpoint is found by watching the changes in trace spread through the total range of adjustment of the control. Set the control for a trace spread half-way between maximum loop gain and minimum loop gain.

Now adjust the GAIN control for unity loop gain as indicated at the right of Fig. 5-8A.

NOTE

If in the previous risetime adjusting step the sampling sweep unit is not a Type 3T2, random sampling is not available to show unity loop gain dot response displays. In this case, each time the loop gain is to be checked, the signal and sweep rate and triggering must each be changed. The proper procedure for checking loop gain using a Type 3T4 or Type 3T77A sampling sweep unit follows:

1. Set the Type 284 Period switch to 1 μ s, the Mode switch for a square wave output and the Square Wave Amplitude control for 1.0 V output. Install the variable attenuator between the Type 284 and the sampling head input.

2. Set the sweep rate to 0.2 μ s/Div. Remove the trigger cable from the Ext Trigger input connector and set the Trigger Sensitivity control clockwise for a free run trace. It may then be necessary to adjust the Recovery Time control for a proper display.

3. A proper Type S-1 unity loop gain dot response display is shown in Fig. 5-9B. Note that the amplitude is the same as the square wave signal of Fig. 5-9A when the loop gain linearity is checked in the next step.

4. The photograph of Fig. 5-9B is a time exposure of four sweeps, making the photo look similar to the CRT display as viewed by the calibrating technician.

5. Thus, the preceding risetime adjustment step requires that the sampling head signal source be changed from the Type 284 fast Pulse Output to the Square Wave Output for checking loop gain, when the sampling sweep unit is not a Type 3T2.

Performance Check/Recalibration—Type S-1

5. Check Loop Gain Linearity

Requirement—Dot will move full amplitude $\pm\%$, of any signal up to 500 mV peak to peak when sampling sweep unit is either double triggered or free run.

The connections between the Type 284 and the sampling head are changed in this step. The head can be either on the extender cable with or without the case installed, or it can be in the Type 3S2 with the case in place.

Connections between the Type 284 Square Wave Output connector and the sampling head input connector includes attenuation. The attenuation can be attained either by fixed 50 Ω GR-874 type attenuators, or the special variable attenuator, item 11 of the equipment required list.

Attenuation is 2X for the Type S-1 when the Square Wave Amplitude is 1.0 volt.

a. Install the correct attenuator to the Type 284 Square Wave Output connector. Connect the output side of the attenuator to the sampling head input connector.

b. Set the Type 284 Period switch to 100 ns (set it to 1 μ s when the sampling sweep unit is other than a Type 3T2). Set the Type 3T2 Range switch to 10 μ s, the Time Magnifier to $\times 50$ and the Start Point Switch to With Trigger.

c. Set the Type 3S2 Units/Div switch to 100. Obtain a triggered square wave display.

Set the With Trigger display amplitude to exactly 5 divisions (500 mV input). Then adjust the Type 3S2 units/div Variable control counter clockwise until the display is 4 divisions peak to peak. This sets the display at 25% per major graticule division.

d. Set the Type 3T2 Start Point switch to Before Trigger (or free run the time base unit at 0.5 μ s/div if not a Type 3T2). Obtain a triggered display.

Set the Type 3S2 Dot Response control so the top of the square wave is at unity loop gain (one trace). The bottom of the square wave can show two traces, but the dot response overshoot or undershoot must not be greater than 5%, or 1 minor graticule divisions. (5% of Fig. 5-10B is 1.25 minor graticule divisions.)

If the dot response overshoots or undershoots more than 5%, the problem is either unbalanced sampling bridge diodes, unbalanced strobe pulses to the bridge or the sampling unit Smoothing Balance control requires adjustment. If no components on either the strobe generator board or the sampler board are broken (or unsoldered), change the sampling diodes after reading the Note in Step 2d. Damage to leadless capacitors is about the only way the strobe pulse amplitudes can be unbalanced, and this is unlikely with normal care of the instrument.

6. Preliminary Bridge Bal Adjust

a. Place the 20 cm air line on the sampling head input connector. Leave the other end of the line open.

Free run the sampling sweep unit to obtain a no-signal trace.

b. Set the Type 3S2 DC Offset control for zero volts at the front panel Offset jack. Use either the test oscilloscope or a bench multimeter to determine zero volts.

c. As the Type 3S2 Units/Div switch is operated through its ranges, adjust the sampling head BRIDGE BAL control (R22) for no more than one division of vertical shift in the trace. (This control adjustment varies with the case on or off the sampling head, and the control must be readjusted when changing operation to an in extender cable.)

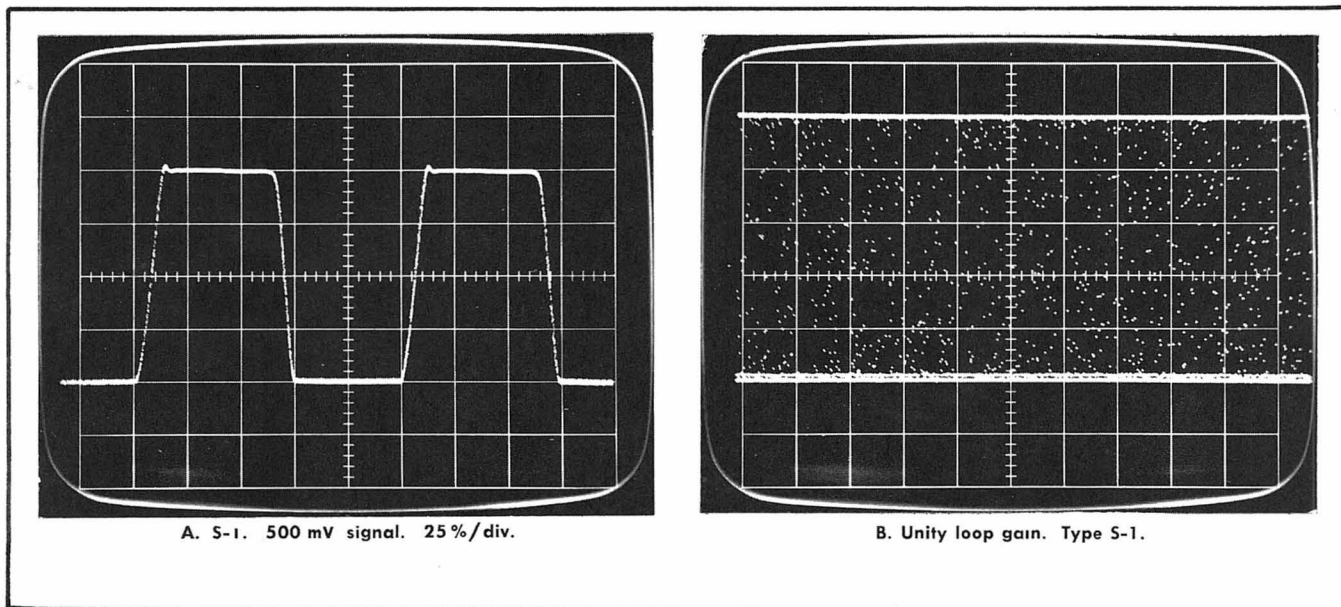

Fig. 5-9. A is obtained with Type 3T2 in random mode. B is obtained with Type 3T4 or Type 3T77A at 0.2 μ s/div, free run. No external trigger signal applied.

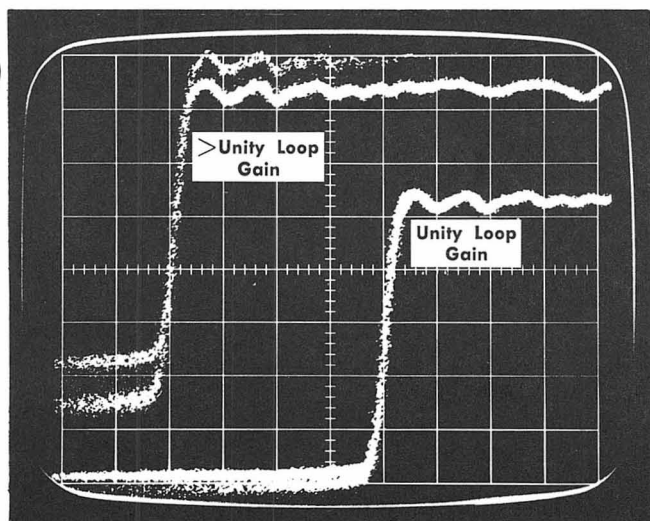

Fig. 5-10. Double exposure while adjusting R13, Transient Response control.

7. Adjust Transient Response Control, R13 ①

a. Connect the Type 284 Square Wave Output connector to the sampling head input. Use proper attenuation (or the variable attenuator) for 0.5 volts to the Type S-1.

Set the Type 284 Period switch to $1 \mu\text{s}$. Set the sweep rate to $1 \mu\text{s}/\text{div}$ and obtain a triggered display.

b. The display should be one cycle per division with the square wave top and bottom flat (parallel to a graticule line). Fig. 5-10 is a double exposure showing a correct adjustment of the TRANSIENT RESPONSE control, and an incorrect adjustment. The tilt of the square wave can be either rising or falling when R13 is not correctly adjusted.

c. Adjust R13 so the square wave display is flat.

8. Check Pulse Flatness Deviation

Requirement—Pulse will not deviate from flat more than $+1/2\%$ to -3% for first 5 ns after pulse reaches 50% amplitude, nor will it deviate more than $+1/2\%$ to $-1/2\%$ (total of 1%) thereafter.

a. Connect the 20 cm air line to the Type 284 Pulse Output connector and the Sampling Head to the other end of the air line.

Set the sweep rate to $2 \text{ ns}/\text{Div}$, and the vertical for a 5 div display at $100 \text{ mV}/\text{Div}$ (use the Variable if needed). Then change the mV/Div control (without moving the Variable) to $5 \text{ mV}/\text{Div}$ or 1% per division. Bring the pulse top into view with the DC Offset control. See Fig. 5-11A.

b. Time-position the display so the pulse rise is about a trace width inside the graticule edge. Check along the trace bottom for deviations as listed in the requirements, and as shown in Fig. 5-11.

Change the sweep rate as listed under the three parts of Fig. 5-11, and check for deviations as shown.

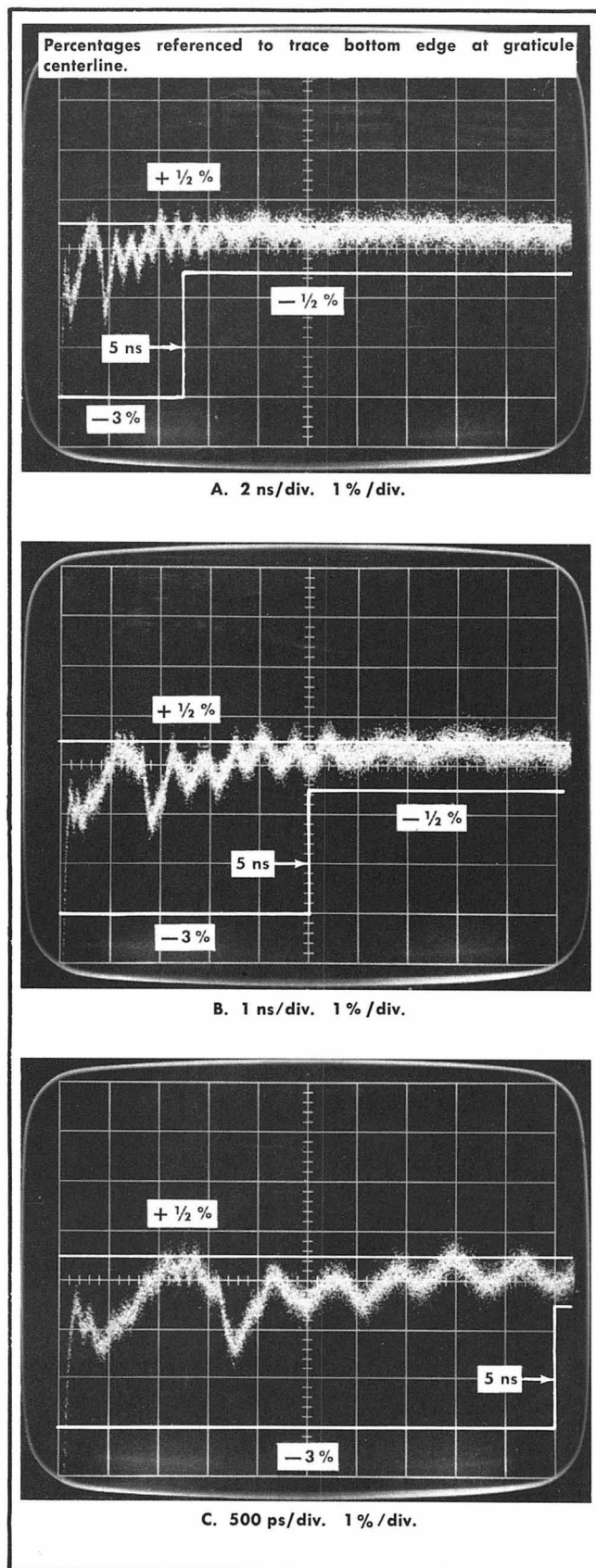

Fig. 5-11. Check of pulse flatness deviation. Step 8.

Performance Check/Recalibration—Type S-1

NOTE

The major dip 1.7 ns after the pulse rise is due to the Type 284 Pulse Generator reverse termination. Some other minor aberrations are also due to the Type 284. The requirement limits include deviations that are part of the Type 284. Therefore, the limits apply only when testing with the Type 284, and with a 20 cm air line between the pulser and the sampling head.

c. If either unit exceeds the pulse flatness deviation limits above, check the mechanical fit of the input connector. An improper (or loose) fit of the coaxial transition from round to flat at the Sampler Board input causes excessive aberrations when viewing a fast pulse. Also, check the solder connections between the round center conductor and the Sampler Board. See the Maintenance section of this manual.

9. Check Trace Shift With Trigger Rate Change From 30 Hz to 50 kHz

Requirement—A no-signal trace will not shift vertically more than 0 mV when the sampling sweep unit external trigger rate is changed from 30 Hz to 50 kHz.

a. Use the test oscilloscope as a trigger rate generator. Use the front panel + Gate signal (+20 volts peak) to drive the sampling sweep unit external trigger input. Feed the + Gate directly to the Type 3T2 1 M Ω /UHF Sync connector and trigger on the — Polarity of the signal. (If the time base unit is a Type 3T4 or 3T77A, place a 10 k Ω , 1/2 watt resistor between the test oscilloscope + Gate terminal and the time base external 50 Ω trigger input connector to provide 100 mV of triggering signal.)

Set the test oscilloscope A sweep controls for a free run sweep. To obtain a 30 Hz trigger signal, set the Time/Div switch to 0.5 ms and the Variable time/div control to a position about 45° left of the top center. To obtain a 50 kHz trigger signal, set the Time/Div switch to 20 μ s and the Variable time/div to a position 45° clockwise from bottom center.

b. Place either the 20 cm air line or a 50 Ω termination on the sampling head input connector. Set the sampling sweep unit for an external triggered sweep rate 50 ns/Div (to assure the shortest trigger circuit holdoff period, and that the triggering rate can actually follow the external triggering signal repetition rate).

c. Set the Type 3S2 Units/Div control to 10. Connect the external trigger rate generator signal to the sampling sweep unit and obtain a triggered sweep at either 30 Hz or 50 kHz repetition rate. Set the Type 3S2 DC Offset control to place the trace at one of the graticule lines.

d. Switch the trigger rate generator through its ranges to the other frequency limit and check that the CRT trace does not move up or down farther than a total of one division.

e. If the trace moves too far, change either the head avalanche transistor (Q69) or the sampling bridge diodes. Changing either of these parts require starting this procedure again at Step 1.

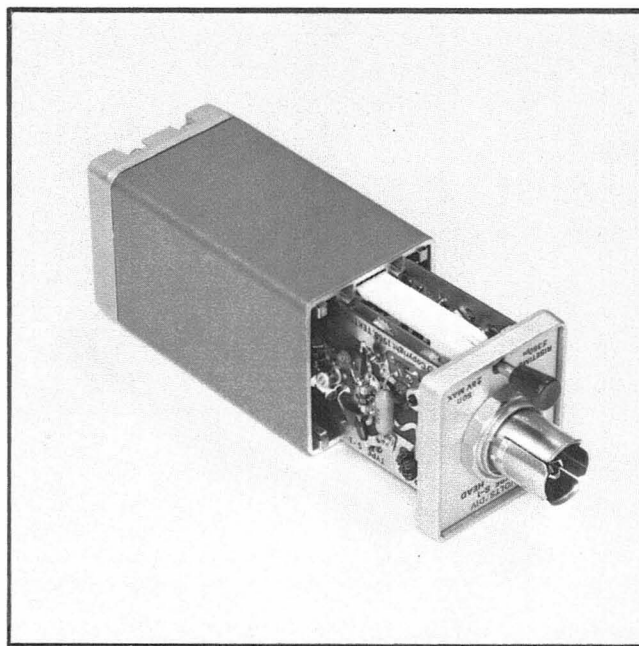

Fig. 5-12. Correct board and latch positions when reinstalling the Sampling Head case.

10. Final Bridge Bal Adjust

a. Place the sampling head case on the head, securing the four mounting bolts at the rear.

Fig. 5-12 shows the correct orientation of the sampling head case when reinstalling it. Note that the Preamplifier and Strobe Generator boards slide between part of the case and the zig-zag spring that runs from the front to the back. Correct case orientation places the one hole in the case over the Bridge Bal control. In sliding the case on, the white plastic locking latch must be fitted into part of the casting.

The rear casting cannot be mounted incorrectly because the trigger pickoff output coaxial connector fits through a hole in the casting. Place the rear casting in place before inserting the four long mounting bolts. Fit the rear casting and case in place by hand so there is no space between either end casting and the case before tightening the bolts.

Place the 20 cm air line on the head input connector.

b. Place the head either inside the Type 3S2 Channel A compartment, or upon the extender cable with which it is normally used. If the head is not normally used on an extender cable, adjust the Bridge Bal control with the head inside the Type 3S2.

c. Free run the Type 3T2 with a 50 ns sweep rate (a Type 3T4 or Type 3T77A at .5 μ s/div). Set the Channel A DC Offset control for zero volts at the front panel Offset connector. Center the trace with the Position control.

d. Operate the Type 3S2 Units/Div switch through its ranges and adjust the BRIDGE BAL control (through the hole in the left side of the case) for not more than one division of vertical shift.

11. Check Tangential Display Noise

NOTE

When making a visual noise reading from a sampling display, the eye interprets a noise value which is neither the RMS nor the peak to peak value. Since most observers agree that the displayed noise value is approximately 3 times the RMS value, the Tangential Noise here defined is 3 times the RMS value. (The measurement technique given produces acceptable agreement between various operators as to the instrument's noise value.)

Requirement—Tangential noise will be not greater than 2 mV, with the case on the sampling head.

a. Install a $5 \times 50 \Omega$ attenuator on the Type 284 Square Wave Output connector. Install the special variable attenuator onto the $5 \times$ attenuator. Connect a 50Ω coaxial cable (RG-58/CU, 5 ns signal delay) between the variable attenuator and the sampling head input connector. (The sampling head can be either inside the Type 3S2, or on an extender cable. The case must be in place on the head.)

b. Set the Type 284 controls:

Period	$1 \mu\text{s}$
Square Wave Amplitude	100 mV
Lead Time	Optional

c. Set the Type 3S2 controls:

Units/Div	5
-----------	---

d. Set the sampling sweep unit controls:

Trig Sensitivity	Clockwise - free run
Sweep rate	$1 \mu\text{s}/\text{div}$

Remove any external trigger cable from the sampling sweep unit external trigger input connector.

e. Refer to Fig. 5-14 during the following noise measurement procedure.

(1) Obtain a display (1) of two traces. Adjust the variable attenuator until the two traces blend together just to the point (2) at which they appear as one trace.

(2)

Set the Type 284 Square Wave Amplitude control to 1.0 V ($\times 10$ signal amplitude). The display (3) now has a tangential

deflection factor of 0.75 mV/div. ($E_{\text{tangential}}$ per division is equal to the Type 3S2 units/div setting of 5 mV divided by 2, times 3 divided by 10 = 0.75 mV/div). Therefore, the 2 mV tangential noise limit includes 2.66 graticule divisions (3) of Fig. 5-14. Check that the bottom edges of the two traces are not more than 2.66 divisions apart. Waveforms (3) of Fig. 5-14 measure as 1.1 mV tangential noise.

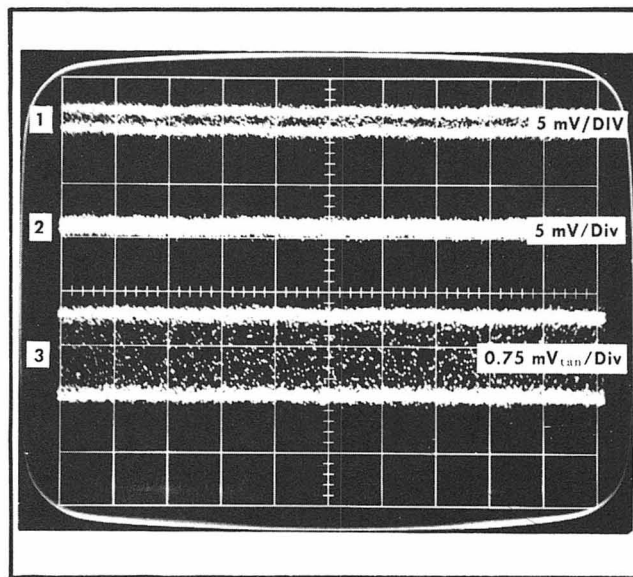

Fig. 5-13. Triple exposures of Tangential noise measurements, Step 11.

Determining Tangential Noise Deflection Factor

The noise displays (3 of Fig. 5-13) have a noise deflection factor based upon the signal amplitude, the Type 3S2 Units/Div switch setting, the fact that the final trace separation is twice the RMS noise, and that the tangential noise is then 3 times the RMS noise. The square wave signal amplitude that makes two traces appear as one sets the trace separation to twice the RMS noise. The procedure used here then permits a noise deflection factor to be determined by dividing the input mV/div deflection factor by 2 (trace separation is $2 \times$ the RMS noise), multiplying by 3 (tangential noise is $3 \times$ the RMS noise) and then dividing by 10 (the signal amplitude change complement).

f. If the tangential noise is outside the required limits, return to Step 4. Choose an Avalanche Volts setting that produces minimum noise right after the pulse rise (in With Trigger sweep mode). If it is impossible to obtain a sufficiently low noise figure, replace Q69 and repeat the rest of the procedure again.

REPLACEABLE ELECTRICAL PARTS

PARTS ORDERING INFORMATION

Replacement parts are available from or through your local Tektronix, Inc. Field Office or representative.

Changes to Tektronix instruments are sometimes made to accommodate improved components as they become available, and to give you the benefit of the latest circuit improvements developed in our engineering department. It is therefore important, when ordering parts, to include the following information in your order: Part number, instrument type or number, serial number, and modification number if applicable.

If a part you have ordered has been replaced with a new or improved part, your local Tektronix, Inc. Field Office or representative will contact you concerning any change in part number.

Change information, if any, is located at the rear of this manual.

SPECIAL NOTES AND SYMBOLS

X000 Part first added at this serial number
00X Part removed after this serial number

ITEM NAME

In the Parts List, an Item Name is separated from the description by a colon (:). Because of space limitations, an Item Name may sometimes appear as incomplete. For further Item Name identification, the U.S. Federal Cataloging Handbook H6-1 can be utilized where possible.

ABBREVIATIONS

ACTR	ACTUATOR	PLSTC	PLASTIC
ASSY	ASSEMBLY	QTZ	QUARTZ
CAP	CAPACITOR	RECP	RECEPTACLE
CER	CERAMIC	RES	RESISTOR
CKT	CIRCUIT	RF	RADIO FREQUENCY
COMP	COMPOSITION	SEL	SELECTED
CONN	CONNECTOR	SEMICOND	SEMICONDUCTOR
ELCTLT	ELECTROLYTIC	SENS	SENSITIVE
ELEC	ELECTRICAL	VAR	VARIABLE
INCAND	INCANDESCENT	WW	WIREWOUND
LED	LIGHT EMITTING DIODE	XFMR	TRANSFORMER
NONWIR	NON WIREWOUND	XTAL	CRYSTAL

CROSS INDEX—MFR. CODE NUMBER TO MANUFACTURER

Mfr. Code	Manufacturer	Address	City, State, Zip
01121	ALLEN-BRADLEY COMPANY	1201 2ND STREET SOUTH	MILWAUKEE, WI 53204
03888	KDI PYROFILM CORPORATION	60 S JEFFERSON ROAD	WHIPPANY, NJ 07981
04713	MOTOROLA, INC., SEMICONDUCTOR PROD. DIV.	5005 E MCDOWELL RD, PO BOX 20923	PHOENIX, AZ 85036
07263	FAIRCHILD SEMICONDUCTOR, A DIV. OF FAIRCHILD CAMERA AND INSTRUMENT CORP.	464 ELLIS STREET	MOUNTAIN VIEW, CA 94042
07910	TELEDYNE SEMICONDUCTOR	12515 CHADRON AVE.	HAWTHORNE, CA 90250
17540	ALPHA INDUSTRIES, INC.	20 SYLVAN RD.	WOBURN, MA 01801
50157	MIDWEST COMPONENTS INC.	P. O. BOX 787 1981 PORT CITY BLVD.	MUSKEGON, MI 49443
51642	CENTRE ENGINEERING INC.	2820 E COLLEGE AVENUE	STATE COLLEGE, PA 16801
56289	SPRAGUE ELECTRIC CO.	87 MARSHALL ST.	NORTH ADAMS, MA 01247
59660	TUSONIX INC.	2155 N FORBES BLVD	TUCSON, AZ 85705
72982	ERIE TECHNOLOGICAL PRODUCTS, INC.	644 W. 12TH ST.	ERIE, PA 16512
73138	BECKMAN INSTRUMENTS, INC., HELIPOT DIV.	2500 HARBOR BLVD.	FULLERTON, CA 92634
80009	TEKTRONIX, INC.	P O BOX 500	BEAVERTON, OR 97077
91418	RADIO MATERIALS COMPANY, DIV. OF P.R. MALLORY AND COMPANY, INC.	4242 W BRYN MAWR	CHICAGO, IL 60646
91637	DALE ELECTRONICS, INC.	P. O. BOX 609	COLUMBUS, NE 68601
98291	SEAELECTRO CORP.	225 HOYT	MAMARONECK, NY 10544

Ckt No.	Tektronix	Serial/Model No.		Name & Description	Mfr Code	Mfr Part Number
	Part No.	Eff	Dscont			
A	670-0163-00	B010100	B104514	CKT CARD ASSY:	80009	670-0163-00
A	670-0163-01	B104515		CKT BOARD ASSY:PREAMPLIFIER	80009	670-0163-01
A	670-0164-00	B010100	B069999	CKT BOARD ASSY:STROBE	80009	670-0164-00
A	670-0164-01	B070000		CKT CARD ASSY:	80009	670-0164-01
A	670-0165-00	B010100	B069999	CKT CARD ASSY:	80009	670-0165-00
A	670-0165-01	B070000	B093229	CKT CARD ASSY:	80009	670-0165-01
A	670-0165-02	B093230	B104514	CKT BOARD ASSY:GATE	80009	670-0165-02
A	670-0165-03	B104515		CKT BOARD ASSY:GATE	80009	670-0165-03
C5	283-0133-00			CAP.,FXD,CER DI:5PF,5%,50V	72982	8300 002C0H0509C
C6	283-0133-00			CAP.,FXD,CER DI:5PF,5%,50V	72982	8300 002C0H0509C
C7	283-0093-00	B010100	B089999	CAP.,FXD,CER DI:15PF,20%,50V	72982	811-565C472J
C7	283-0313-00	B090000		CAP.,FXD,CER DI:15PF,10%,100V	72982	A02AL4A4LC1G0150
C8	283-0093-00	B010100	B089999	CAP.,FXD,CER DI:15PF,20%,50V	72982	811-565C472J
C8	283-0313-00	B090000		CAP.,FXD,CER DI:15PF,10%,100V	72982	A02AL4A4LC1G0150
C14	283-0136-00			CAP.,FXD,CER DI:10PF,5%,50V	51642	A100050-NP0-100J
C19	283-0121-00			CAP.,FXD,CER DI:0.001UF,20%,200V	56289	40C73A5
C28	290-0188-00			CAP.,FXD,ELCTLT:0.1UF,10%,35V	56289	162D104X9035BC2
C34	283-0067-00			CAP.,FXD,CER DI:0.001UF,10%,200V	59660	835-515-Z5D0102K
C40	283-0067-00			CAP.,FXD,CER DI:0.001UF,10%,200V	59660	835-515-Z5D0102K
C43	290-0246-00			CAP.,FXD,ELCTLT:3.3UF,10%,15V	56289	162D335X9015CD2
C44	283-0003-00			CAP.,FXD,CER DI:0.01UF,+80-20%,150V	91418	SP103Z151-4R9
C45	283-0066-00			CAP.,FXD,CER DI:2.5PF,20%,200V	72982	8101-047C0J259D
C46	283-0000-00			CAP.,FXD,CER DI:0.001UF,+100-0%,500V	59660	0831610Y5P0102D
C49	283-0003-00			CAP.,FXD,CER DI:0.01UF,+80-20%,150V	91418	SP103Z151-4R9
C51	283-0121-00	B010100	B069999	CAP.,FXD,CER DI:0.001UF,20%,200V	56289	40C73A5
C51	283-0093-00	B070000	B089999	CAP.,FXD,CER DI:15PF,20%,50V	72982	811-565C472J
C51	283-0313-00	B090000		CAP.,FXD,CER DI:15PF,10%,100V	72982	A02AL4A4LC1G0150
C53	283-0121-00	B010100	B069999	CAP.,FXD,CER DI:0.001UF,20%,200V	56289	40C73A5
C53	283-0093-00	B070000	B089999	CAP.,FXD,CER DI:15PF,20%,50V	72982	811-565C472J
C53	283-0313-00	B090000		CAP.,FXD,CER DI:15PF,10%,100V	72982	A02AL4A4LC1G0150
C55	290-0134-00	B010100	B069999	CAP.,FXD,ELCTLT:22UF,20%,15V	56289	150D226X0015B2
C59	283-0072-01	B010100	B069999	CAP.,FXD,CER DI:0.01UF,+80-20%,200V	51642	S-300-200Z5V103M
C63	283-0103-00	B010100	B069999	CAP.,FXD,CER DI:180PF,5%,500V	59660	831-518-Z5D0181J
C64	283-0103-00	B010100	B069999	CAP.,FXD,CER DI:180PF,5%,500V	59660	831-518-Z5D0181J
C65	283-0005-00	B010100	B069999	CAP.,FXD,CER DI:0.01UF,+100-0%,250V	72982	8131N300Z5U0103P
C65	283-0121-00	B070000		CAP.,FXD,CER DI:0.001UF,20%,200V	56289	40C73A5
C69	281-0612-00	B010100	B069999	CAP.,FXD,CER DI:5.6PF,+/-0.5PF,500V	59660	374-018-COH0569D
C71	283-0121-00			CAP.,FXD,CER DI:0.001UF,20%,200V	56289	40C73A5
D5	152-0360-00	B010100	B049999	SEMICONV DEVICE:MATCHED PAIR	80009	152-0360-00
D6	-----			(PART OF D5)		
D5	152-0471-00	B050000	B104514	SEMICONV DEVICE:SILICON,MATCHED PAIR	80009	152-0471-00
D6	-----			(PART OF D5)		
D5	152-0471-01	B104515		SEMICONV DEVICE:SCHOTTKY PR,9V,0.3PF	17540	DMJ6786-98
D6	-----			(PART OF D5)		
D41	152-0185-00			SEMICONV DEVICE:SILICON,40PIV,150MA	07910	1N4152
D61	152-0335-00	B010100	B069999	SEMICONV DEVICE:SILICON,SNAP-OFF	80009	152-0335-00
L12	276-0543-00			SHLD BEAD,ELEK:FERRITE	80009	276-0543-00
L16	276-0543-00	B093060		SHLD BEAD,ELEK:FERRITE	80009	276-0543-00
L17	276-0543-00			SHLD BEAD,ELEK:FERRITE	80009	276-0543-00
L49	108-0440-00			COIL,RF:8UH,TOROIDAL INDUCTOR	80009	108-0440-00
L55	120-0382-00	B010100	B069999	XFMR,TOROID:14 TURNS,SINGLE	80009	120-0382-00

Replaceable Electrical Parts—S-1

Ckt No.	Tektronix	Serial/Model No.		Name & Description	Mfr	Mfr Part Number
	Part No.	Eff	Dscont		Code	
L60	108-0170-00	B010100	B069999	COIL,RF:FIXED,0.5UH	80009	108-0170-00
L62	108-0170-00	B010100	B069999	COIL,RF:FIXED,0.5UH	80009	108-0170-00
P17	175-0481-00			CABLE ASSY,RF:50 OHM COAX,3.5 L	80009	175-0481-00
P51	131-0391-00			CONNECTOR,RCPT,;50 OHM,COAX,SNAP-ON MALE	98291	51-051-0049
P53	131-0391-00			CONNECTOR,RCPT,;50 OHM,COAX,SNAP-ON MALE	98291	51-051-0049
Q13	151-0212-00			TRANSISTOR:SILICON,NPN	04713	SRF 518
Q17	151-0212-00			TRANSISTOR:SILICON,NPN	04713	SRF 518
Q31	151-1012-00			TRANSISTOR:SILICON,FE,N-CHANNEL	80009	151-1012-00
Q41	151-0224-00			TRANSISTOR:SILICON,NPN	07263	SA24850
Q45	151-0224-00			TRANSISTOR:SILICON,NPN	07263	SA24850
Q55	151-0224-00	B010100	B069999	TRANSISTOR:SILICON,NPN	07263	SA24850
Q69	153-0556-00			TRANSISTOR:SILICON,5V,SEL	80009	153-0556-00
R3	317-0391-00			RES.,FXD,CMPSN:390 OHM,5%,0.125W	01121	BB3915
R4	307-0098-00			RES.,FXD,FILM:56.4 OHM,0.50%	03888	125R250T56R40D
R5	317-0201-00	B010100	B093229	RES.,FXD,CMPSN:200 OHM,5%,0.125W	01121	BB2015
R5	317-0201-02	B093230		RES.,FXD,CMPSN:200 OHM,5%,0.125W	01121	BB2015
R6	317-0201-00	B010100	B093229	RES.,FXD,CMPSN:200 OHM,5%,0.125W	01121	BB2015
R6	317-0201-02	B093230		RES.,FXD,CMPSN:200 OHM,5%,0.125W	01121	BB2015
R7A	317-0151-00	B010100	B093229	RES.,FXD,CMPSN:150 OHM,5%,0.125W	01121	BB1515
R7A	317-0151-02	B093230		RES.,FXD,CMPSN:150 OHM,5%,0.125W	01121	BB1515
R7B	317-0101-00	B010100	B069999	RES.,FXD,CMPSN:100 OHM,5%,0.125W	01121	BB1015
R8A	317-0151-00	B010100	B093229	RES.,FXD,CMPSN:150 OHM,5%,0.125W	01121	BB1515
R8A	317-0151-02	B093230		RES.,FXD,CMPSN:150 OHM,5%,0.125W	01121	BB1515
R8B	317-0101-00	B010100	B069999	RES.,FXD,CMPSN:100 OHM,5%,0.125W	01121	BB1015
R10	317-0510-00			RES.,FXD,CMPSN:51 OHM,5%,0.125W	01121	BB5105
R12	315-0152-00			RES.,FXD,CMPSN:1.5K OHM,5%,0.25W	01121	CB1525
R13	311-0643-00			RES.,VAR,NONWIR:50 OHM,10%,0.50W	73138	82-33-2
R14	317-0271-00			RES.,FXD,CMPSN:270 OHM,5%,0.125W	01121	BB2715
R15	317-0102-00			RES.,FXD,CMPSN:1K OHM,5%,0.125W	01121	BB1025
R17	317-0102-00			RES.,FXD,CMPSN:1K OHM,5%,0.125W	01121	BB1025
R18	317-0360-00			RES.,FXD,CMPSN:36 OHM,5%,0.125W	01121	BB3605
R19	317-0511-00			RES.,FXD,CMPSN:510 OHM,5%,0.125W	01121	BB5115
R20	321-0385-00			RES.,FXD,FILM:100K OHM,1%,0.125W	91637	MFF1816G10002F
R21	321-0253-00			RES.,FXD,FILM:4.22K OHM,1%,0.125W	91637	MFF1816G42200F
R22	311-0609-00			RES.,VAR,NONWIR:2K OHM,10%,0.50W	73138	82-26-1
R23	321-0253-00			RES.,FXD,FILM:4.22K OHM,1%,0.125W	91637	MFF1816G42200F
R24	321-0385-00			RES.,FXD,FILM:100K OHM,1%,0.125W	91637	MFF1816G10002F
R26	311-0613-00			RES.,VAR,NONWIR:100K OHM,10%,0.50W	73138	82-27-2
R28	317-0473-00			RES.,FXD,CMPSN:47K OHM,5%,0.125W	01121	BB4735
R29	317-0473-00			RES.,FXD,CMPSN:47K OHM,5%,0.125W	01121	BB4735
R31	301-0912-00			RES.,FXD,CMPSN:9.1K OHM,5%,0.50W	01121	EB9125
R33	307-0124-00			RES.,THERMAL:5K OHM,10%	50157	1D1618
R34	317-0202-00			RES.,FXD,CMPSN:2K OHM,5%,0.125W	01121	BB2025
R35	301-0103-00			RES.,FXD,CMPSN:10K OHM,5%,0.50W	01121	EB1035
R40	317-0224-00			RES.,FXD,CMPSN:220K OHM,5%,0.125W	01121	BB2245
R41	317-0223-00			RES.,FXD,CMPSN:22K OHM,5%,0.125W	01121	BB2235
R42	317-0122-00			RES.,FXD,CMPSN:1.2K OHM,5%,0.125W	01121	BB1225
R44	317-0391-00			RES.,FXD,CMPSN:390 OHM,5%,0.125W	01121	BB3915
R45	317-0303-00			RES.,FXD,CMPSN:30K OHM,5%,0.125W	01121	BB3035
R46	311-0633-00	B010100	B059999	RES.,VAR,NONWIR:5K OHM,10%,0.50W	73138	82-30-1
R46	311-0607-00	B060000		RES.,VAR,NONWIR:10K OHM,10%,0.50W	73138	82-25-2
R47	315-0472-00			RES.,FXD,CMPSN:4.7K OHM,5%,0.25W	01121	CB4725

Ckt No.	Tektronix	Serial/Model No.		Name & Description	Mfr Code	Mfr Part Number
	Part No.	Eff	Dscont			
R51	317-0390-00	B070000		RES.,FXD,CMPSN:39 OHM,5%,0.125W	01121	BB3905
R53	317-0390-00	B070000		RES.,FXD,CMPSN:39 OHM,5%,0.125W	01121	BB3905
R56	317-0271-00	B010100	B069999	RES.,FXD,CMPSN:270 OHM,5%,0.125W	01121	BB2715
R57	311-0607-00	B010100	B069999	RES.,VAR,NONWIR:10K OHM,10%,0.50W	73138	82-25-2
R59	308-0243-00	B010100	B069999	RES.,FXD,WW:240 OHM,5%,3W	91637	CW2BB240R0J
R60	317-0390-00	B010100	B069999	RES.,FXD,CMPSN:39 OHM,5%,0.125W	01121	BB3905
R62	317-0390-00	B010100	B069999	RES.,FXD,CMPSN:39 OHM,5%,0.125W	01121	BB3905
R65	317-0101-00			RES.,FXD,CMPSN:100 OHM,5%,0.125W	01121	BB1015
R66	311-0644-00			RES.,VAR,NONWIR:20K OHM,10%,0.50W	73138	82-34-1
R68	317-0332-00			RES.,FXD,CMPSN:3.3K OHM,5%,0.125W	01121	BB3325
R70	317-0332-00			RES.,FXD,CMPSN:3.3K OHM,5%,0.125W	01121	BB3325
R71	317-0202-00			RES.,FXD,CMPSN:2K OHM,5%,0.125W	01121	BB2025
R72	315-0203-00			RES.,FXD,CMPSN:20K OHM,5%,0.25W	01121	CB2035
R73	307-0124-00	B010100	B069999	RES.,THERMAL:5K OHM,10%	50157	1D1618
RT73	307-0124-00	B070000		RES.,THERMAL:5K OHM,10%	50157	1D1618
T58	120-0318-00	B070000		XFMR,TOROID:6 TURNS BIFILAR	80009	120-0318-00
T75	120-0544-00			XFMR,TOROID:	80009	120-0544-00
VR28	152-0647-00	B104515		SEMICOND DEVICE:ZENER,0.4W,6.8V,5%	04713	SZG35014K3RL

REPLACEABLE MECHANICAL PARTS

PARTS ORDERING INFORMATION

Replacement parts are available from or through your local Tektronix, Inc. Field Office or representative.

Changes to Tektronix instruments are sometimes made to accommodate improved components as they become available, and to give you the benefit of the latest circuit improvements developed in our engineering department. It is therefore important, when ordering parts, to include the following information in your order: Part number, instrument type or number, serial number, and modification number if applicable.

If a part you have ordered has been replaced with a new or improved part, your local Tektronix, Inc. Field Office or representative will contact you concerning any change in part number.

Change information, if any, is located at the rear of this manual.

SPECIAL NOTES AND SYMBOLS

X000 Part first added at this serial number
00X Part removed after this serial number

FIGURE AND INDEX NUMBERS

Items in this section are referenced by figure and index numbers to the illustrations.

INDENTATION SYSTEM

This mechanical parts list is indented to indicate item relationships. Following is an example of the indentation system used in the description column.

```

1 2 3 4 5           Name & Description
Assembly and/or Component
Attaching parts for Assembly and/or Component
    --- * ---
Detail Part of Assembly and/or Component
Attaching parts for Detail Part
    --- * ---
Parts of Detail Part
Attaching parts for Parts of Detail Part
    --- * ---
  
```

Attaching Parts always appear in the same indentation as the item it mounts, while the detail parts are indented to the right. Indented items are part of, and included with, the next higher indentation. The separation symbol --- * --- indicates the end of attaching parts.

Attaching parts must be purchased separately, unless otherwise specified.

ITEM NAME

In the Parts List, an Item Name is separated from the description by a colon (:). Because of space limitations, an Item Name may sometimes appear as incomplete. For further Item Name identification, the U.S. Federal Cataloging Handbook H6-1 can be utilized where possible.

ABBREVIATIONS

#	INCH NUMBER SIZE	ELECTRN	ELECTRON	IN	INCH	SE	SINGLE END
ACTR	ACTUATOR	ELEC	ELECTRICAL	INCAND	INCANDESCENT	SECT	SECTION
ADPTR	ADAPTER	ELCTLT	ELECTROLYTIC	INSUL	INSULATOR	SEMICOND	SEMICONDUCTOR
ALIGN	ALIGNMENT	ELEM	ELEMENT	INTL	INTERNAL	SHLD	SHIELD
AL	ALUMINUM	EPL	ELECTRICAL PARTS LIST	LPHLDR	LAMPHOLDER	SHLDR	SHOULDERED
ASSEM	ASSEMBLED	EQPT	EQUIPMENT	MACH	MACHINE	SKT	SOCKET
ASSY	ASSEMBLY	EXT	EXTERNAL	MECH	MECHANICAL	SL	SLIDE
ATTEN	ATTENUATOR	FIL	FILLISTER HEAD	MTG	MOUNTING	SLFLKG	SELF-LOCKING
AWG	AMERICAN WIRE GAGE	FLEX	FLEXIBLE	NIP	NIPPLE	SLVG	SLEEVING
BD	BOARD	FLH	FLAT HEAD	NON WIRE	NOT WIRE WOUND	SPR	SPRING
BRKT	BRACKET	FLTR	FILTER	OBD	ORDER BY DESCRIPTION	SQ	SQUARE
BRS	BRASS	FR	FRAME or FRONT	OD	OUTSIDE DIAMETER	SST	STAINLESS STEEL
BRZ	BRONZE	FSTNR	FASTENER	OVB	OVAL HEAD	STL	STEEL
BSHG	BUSHING	FT	FOOT	PH BRZ	PHOSPHOR BRONZE	SW	SWITCH
CAB	CABINET	FXD	FIXED	PL	PLAIN or PLATE	T	TUBE
CAP	CAPACITOR	GSKT	GASKET	PLSTC	PLASTIC	TERM	TERMINAL
CER	CERAMIC	HDL	HANDLE	PN	PART NUMBER	THD	THREAD
CHAS	CHASSIS	HEX	HEXAGON	PNH	PAN HEAD	THK	THICK
CKT	CIRCUIT	HEX HD	HEXAGONAL HEAD	PWR	POWER	TNSN	TENSION
COMP	COMPOSITION	HEX SOC	HEXAGONAL SOCKET	RCPT	RECEPTACLE	TPG	TAPPING
CONN	CONNECTOR	HLCPS	HELICAL COMPRESSION	RES	RESISTOR	TRH	TRUSS HEAD
COV	COVER	HLEXT	HELICAL EXTENSION	RGD.	RIGID	V	VOLTAGE
CPLG	COUPLING	HV	HIGH VOLTAGE	RLF	RELIEF	VAR	VARIABLE
CRT	CATHODE RAY TUBE	IC	INTEGRATED CIRCUIT	RTNR	RETAINER	W	WITH
DEG	DEGREE	ID	INSIDE DIAMETER	SCH	SOCKET HEAD	WSHR	WASHER
DWR	DRAWER	IDENT	IDENTIFICATION	SCOPE	OSCILLOSCOPE	XFMR	TRANSFORMER
		IMPLR	IMPELLER	SCR	SCREW	XSTR	TRANSISTOR

CROSS INDEX—MFR. CODE NUMBER TO MANUFACTURER

Mfr. Code	Manufacturer	Address	City, State, Zip
00779	AMP. INC.	P O BOX 3608	HARRISBURG, PA 17105
12697	CLAROSTAT MFG. CO., INC.	LOWER WASHINGTON STREET	DOVER, NH 03820
22526	BERG ELECTRONICS, INC.	YOUK EXPRESSWAY	NEW CUMBERLAND, PA 17070
24655	GENERAL RADIO CO.	300 BAKER AVE.	CONCORD, MA 01742
57771	STIMPSON, EDWIN B.,CO. INC.	900 SYLVAN AVENUE	BAYPORT, NY 11705
73743	FISCHER SPECIAL MFG. CO.	446 MORGAN ST.	CINCINNATI, OH 45206
79136	WALDES, KOHINOOR, INC.	47-16 AUSTEL PLACE	LONG ISLAND CITY, NY 11101
80009	TEKTRONIX, INC.	P O BOX 500	BEAVERTON, OR 97077
83385	CENTRAL SCREW CO.	2530 CRESCENT DR.	BROADVIEW, IL 60153
83486	ELCO INDUSTRIES, INC.	1103 SAMUELSON ROAD	ROCKFORD, IL 61101
91260	CONNOR SPRING AND MFG. CO.	1729 JUNCTION AVE.	SAN JOSE, CA 95112
98291	SEAELECTRO CORP.	225 HOYT	MAMARONECK, NY 10544

Fig. & Index No.	Tektronix Part No.	Serial/Model No.		Qty	Name & Description					Mfr Code	Mfr Part Number
		Eff	Dscont		1	2	3	4	5		
1-1	333-1040-00			1	PANEL,FRONT:					80009	333-1040-00
-2	386-1338-01			1	SUBPANEL,FRONT:					80009	386-1338-01
-3	384-0687-00	B010100	B069999	1	KNOB:1.44 L X 0.125 OD,SST,W/KNO					80009	384-0687-00
-4	105-0066-00	B010100	B069999	1	STRIKE,LATCH:SAMPLING HEAD					80009	105-0066-00
	214-1226-01	B010100	B069999	1	SPRING,HLCPS:0.18 OD X 0.44 INCH LONG					80009	214-1226-01
	105-0338-00	B070000		1	LATCH ASSEMBLY:SAMPLING HEADS					80009	105-0338-00
	354-0163-00			1	.RING,RETAINING:TRUARC,CAD PLATE					79136	5133-12MD
	384-0687-01			1	.KNOB:1.44 L X 0.125 OD,SST					80009	384-0687-01
	105-0336-00			1	.STRIKE,CATCH:					80009	105-0336-00
-5	131-0553-00			1	CONTACT,ELEC:BRASS,ALBALOY PL					80009	131-0553-00
	132-0137-00			1	CONN,RCPT,ELEC:GR S-1,S-2					80009	132-0137-00
-6	103-0076-00			1	.ADAPTER,CONN:GR TO FLAT XSMN LINE					80009	103-0076-00
	354-0322-00			1	.RING,RETAINING:CIRC PUSH-O U/W 0.687 DIA					83385	OBD
	377-0196-00			1	.INSERT,SCR THD:0.875-32 X 0.75-27 X 0.344					80009	377-0196-00
-7	205-0091-00			1	.SHELL,ADAPTER:					80009	205-0091-00
-8	132-0007-00			1	.RING,RETAINING:0.575 ID X 0.031 THK					91260	132-0007-00B
-9	103-0055-00			1	.CPLG,CONTACT,EL:BRS ALBALOY PLATED					80009	103-0055-00
-10	132-0028-00			1	.INSULATOR,DISK:0.165 ID X 0.625 OD					24655	0874-0700
-11	132-0029-00			1	.CONTACT,ELEC:					24655	0874-0612
-12	132-0133-00			1	.SHELL,ELEC CONN:GR TYPE					80009	132-0133-00
-13	220-0459-00			1	NUT,PLAIN,DODEC:0.875-32 X 1.0,BRS					73743	2XX-64066-101
-14	-----			1	CKT BOARD ASSY:GATE(SEE REPL)						
-15	-----			1	.SEMICONV DEVICE:SI(SEE D5,D6 REPL)						
-16	131-0582-00			3	.CONN,RCPT,ELEC:SNAP-ON FEMALE,MODIFIED					98291	52-052-0049
-17	131-0591-00			8	.CONTACT,ELEC:0.835 INCH LONG					22526	47352
-18	361-0130-00			14	.SPACER,SLEEVE:0.125 L X 0.15-0.188 ID,BRS					80009	361-0130-00
	210-0709-00			7	.EYELET,METALLIC:0.138 OD X 0.258 L,BRS GO ***** (ATTACHING PARTS FOR CKT BD ASSY) *****					57771	A1472
-19	211-0014-00			7	SCREW,MACHINE:4-40 X 0.50 INCH,PNH STL					83385	OBD
-20	210-0586-00			7	NUT,PL,ASSEM WA:4-40 X 0.25,STL ***** (END ATTACHING PARTS) *****					83385	OBD
-21	119-0145-00			2	LINE SECT,RF TR:2.454 X 1.375 X 0.032					80009	119-0145-00
-22	-----			1	CKT BOARD ASSY:STROBE(SEE REPL)						
-23	131-0391-00			2	.CONNECTOR,RCPT,:50 OHM,COAX,SNAP-ON MALE					98291	51-051-0049
-24	136-0252-00	B010100	B069999	6	.SOCKET,PIN TERM:0.145 INCH LONG					00779	2-330808-7
	136-0252-07	B070000		3	.SOCKET,PIN CONN:W/O DIMPLE					22526	75060-012
-25	136-0263-00	B010100	B030479	5	.SOCKET,PIN TERM:U/W 0.025 SQ PIN					00779	85861-3
	136-0263-01	B030480	B069999	5	.SOCKET,PIN TERM:FOR 0.025 INCH SQUARE PIN					00779	85861-2
	136-0263-03	B070000	B092799	4	.SOCKET,PIN TERM:FOR 0.025 INCH SQUARE PIN					00779	85864-2
	136-0263-04	B092800		4	.SOCKET,PIN TERM:FOR 0.025 INCH SQUARE PIN					22526	75377-001
-26	344-0061-00	B010100	B069999	2	.CLIP,ELECTRICAL:DIODE,CU BE GOLD PL					80009	344-0061-00
-27	-----			1	CKT BOARD ASSY:PREAMP(SEE REPL)						
-28	131-0391-00			1	.CONNECTOR,RCPT,:50 OHM,COAX,SNAP-ON MALE					98291	51-051-0049
-29	175-0481-00			1	.CABLE ASSY,RF:50 OHM COAX,3.5 L					80009	175-0481-00
-30	136-0252-00			1	.SOCKET,PIN TERM:0.145 INCH LONG					00779	2-330808-7
-31	136-0263-00	B010100	B030479	9	.SOCKET,PIN TERM:U/W 0.025 SQ PIN					00779	85861-3
	136-0263-01	B030480	B069999	9	.SOCKET,PIN TERM:FOR 0.025 INCH SQUARE PIN					00779	85861-2
	136-0263-03	B070000	B092799	3	.SOCKET,PIN TERM:FOR 0.025 INCH SQUARE PIN					00779	85864-2
	136-0263-04	B092800		3	.SOCKET,PIN TERM:FOR 0.025 INCH SQUARE PIN					22526	75377-001
	210-0707-00			1	.EYELET,METALLIC:0.147 OD X 0.100 INCH LON					12697	OBD
-32	380-0125-00			1	HSG,SAMPLING HD:ALUMINUM					80009	380-0125-00
-33	386-1337-01	B010100	B039999	1	PANEL,REAR:					80009	386-1337-01
	386-1337-10	B040000	B104759	1	PANEL,REAR:					80009	386-1337-00
	386-1337-09	B104760		1	PANEL,REAR: ***** (ATTACHING PARTS) *****					80009	386-1337-09
-34	211-0141-00			4	SCREW,MACHINE:4-40 X 3.250,PNH,SST ***** (END ATTACHING PARTS) *****					83486	OBD

SECTION 8

DIAGRAMS AND CIRCUIT BOARD ILLUSTRATIONS

Symbols and Reference Designators

Electrical components shown on the diagrams are in the following units unless noted otherwise:

- Capacitors = Values one or greater are in picofarads (pF).
Values less than one are in microfarads (μ F).
- Resistors = Ohms (Ω).

Graphic symbols and class designation letters are based on ANSI Standard Y32.2-1975.

Logic symbology is based on ANSI Y32.14-1973 in terms of positive logic. Logic symbols depict the logic function performed and may differ from the manufacturer's data.

The overline on a signal name indicates that the signal performs its intended function when it goes to the low state.

Abbreviations are based on ANSI Y1.1-1972.

Other ANSI standards that are used in the preparation of diagrams by Tektronix, Inc. are:

- Y14.15, 1966 Drafting Practices.
- Y14.2, 1973 Line Conventions and Lettering.
- Y10.5, 1968 Letter Symbols for Quantities Used in Electrical Science and Electrical Engineering.

The following prefix letters are used as reference designators to identify components or assemblies on the diagrams.

A	Assembly, separable or repairable (circuit board, etc)	H	Heat dissipating device (heat sink, heat radiator, etc)	S	Switch or contactor
AT	Attenuator, fixed or variable	HR	Heater	T	Transformer
B	Motor	HY	Hybrid circuit	TC	Thermocouple
BT	Battery	J	Connector, stationary portion	TP	Test point
C	Capacitor, fixed or variable	K	Relay	U	Assembly, inseparable or non-repairable (integrated circuit, etc.)
CB	Circuit breaker	L	Inductor, fixed or variable	V	Electron tube
CR	Diode, signal or rectifier	M	Meter	VR	Voltage regulator (zener diode, etc.)
DL	Delay line	P	Connector, movable portion	W	Wirestrap or cable
DS	Indicating device (lamp)	Q	Transistor or silicon-controlled rectifier	Y	Crystal
E	Spark Gap, Ferrite bead	R	Resistor, fixed or variable	Z	Phase shifter
F	Fuse	RT	Thermistor		
FL	Filter				

The following special symbols may appear on the diagrams:

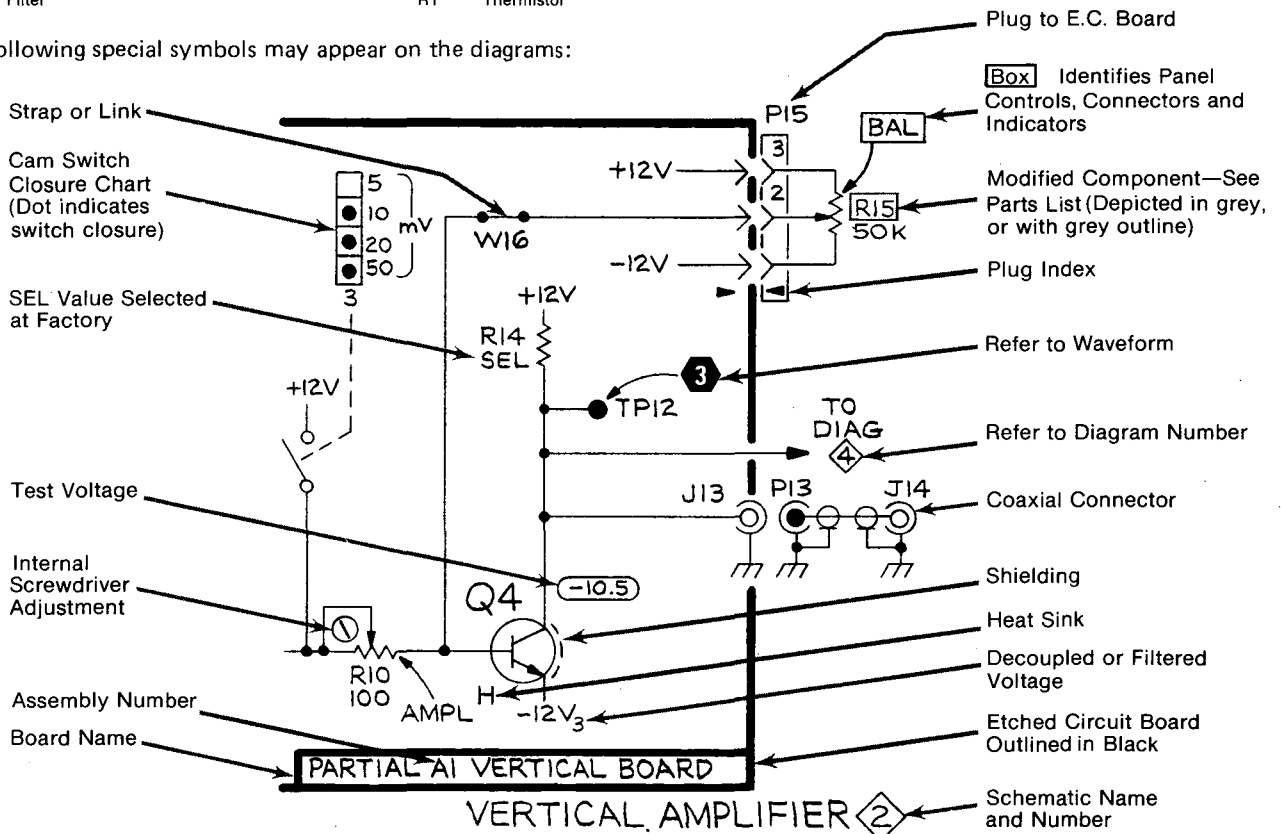

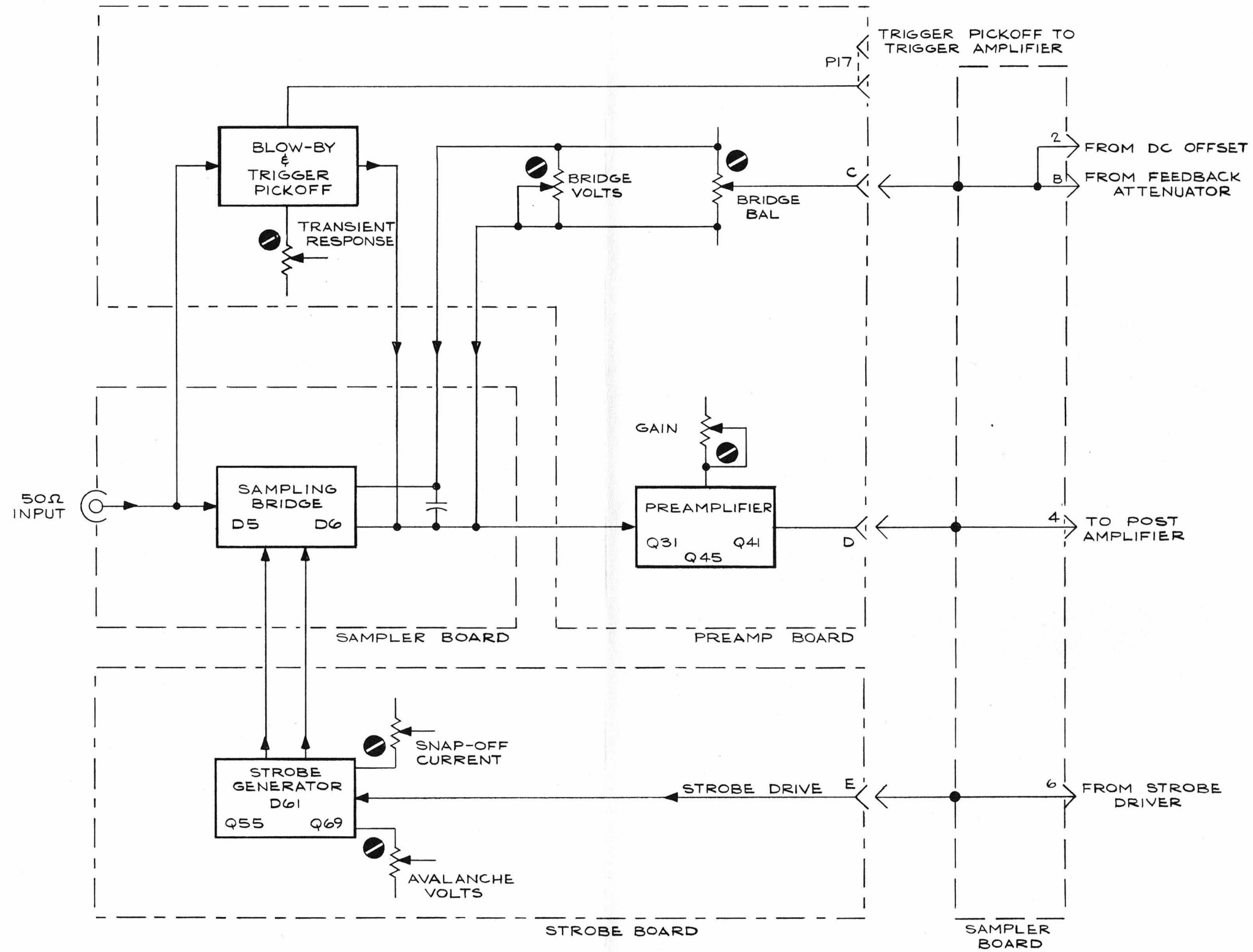

VOLTAGE AND WAVEFORM TEST CONDITIONS

Typical voltage measurements and waveform photographs were obtained under the following conditions unless noted on the individual diagrams:

Test Oscilloscope

Bandwidth	DC to at least 50 MHz
Probe Input	10 Megohms, 7 picofarads
Probe Ground lead	Clipped to Type S-1 chassis
Triggering	External via 1 X probe to Sampling Unit CH A Memory Gate transformer primary Test Point.

DC Voltmeter

Type	Volt-Ohmmeter 20,000 Ω /volt
------	--

Type S-1 conditions

Vertical input signal	Connected on a 3 foot extender cable. Case removed for access to circuits. 50 Ω Termination or Coaxial cable connected. No signal.
-----------------------	--

Sampling Unit

Vertical Position	Centered
DC Offset	Midrange. Zero volts at Offset Out jack.

Sampling Sweep Unit

Type 3T2: use any convenient sweep rate and free run the sweep with Trigger Sensitivity control fully clockwise. Type 3T4 or Type 3T77A: Set Time/Div switch to $.5 \mu s$ and free run the sweep with the Trigger Level control fully clockwise.

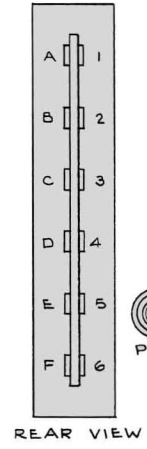
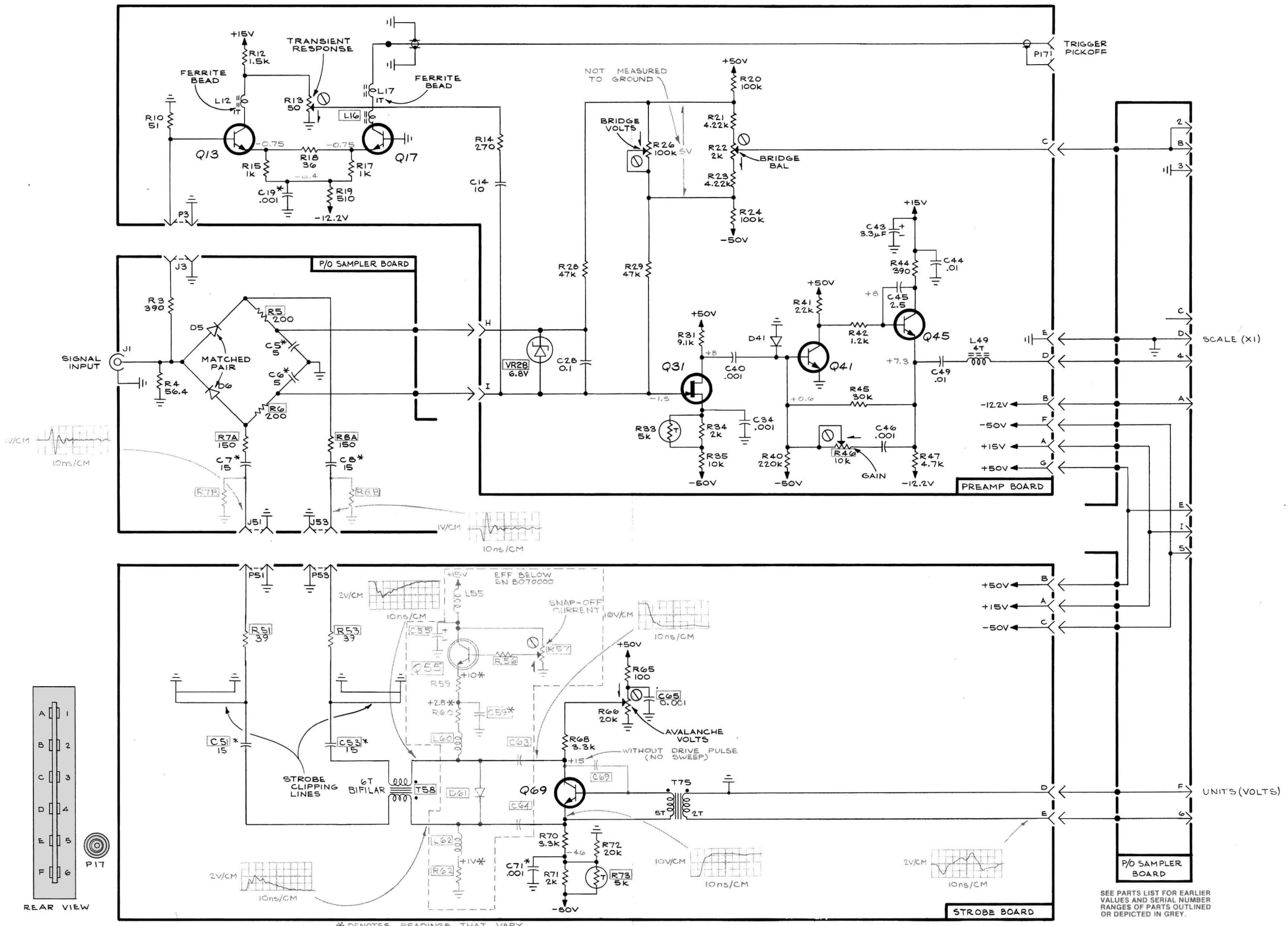

TYPE S-1 SAMPLING HEAD

REV F AUG 1980

SEE PARTS LIST FOR SEMICONDUCTOR TYPES

* DENOTES LEADLESS CAPACITORS

* DENOTES READINGS THAT VARY WITH D61 CHARACTERISTICS.

SEE PARTS LIST FOR EARLIER VALUES AND SERIAL NUMBER RANGES OF PARTS OUTLINED OR DEPICTED IN GREY.

FIG. 1 EXPLODED

FIG. 1

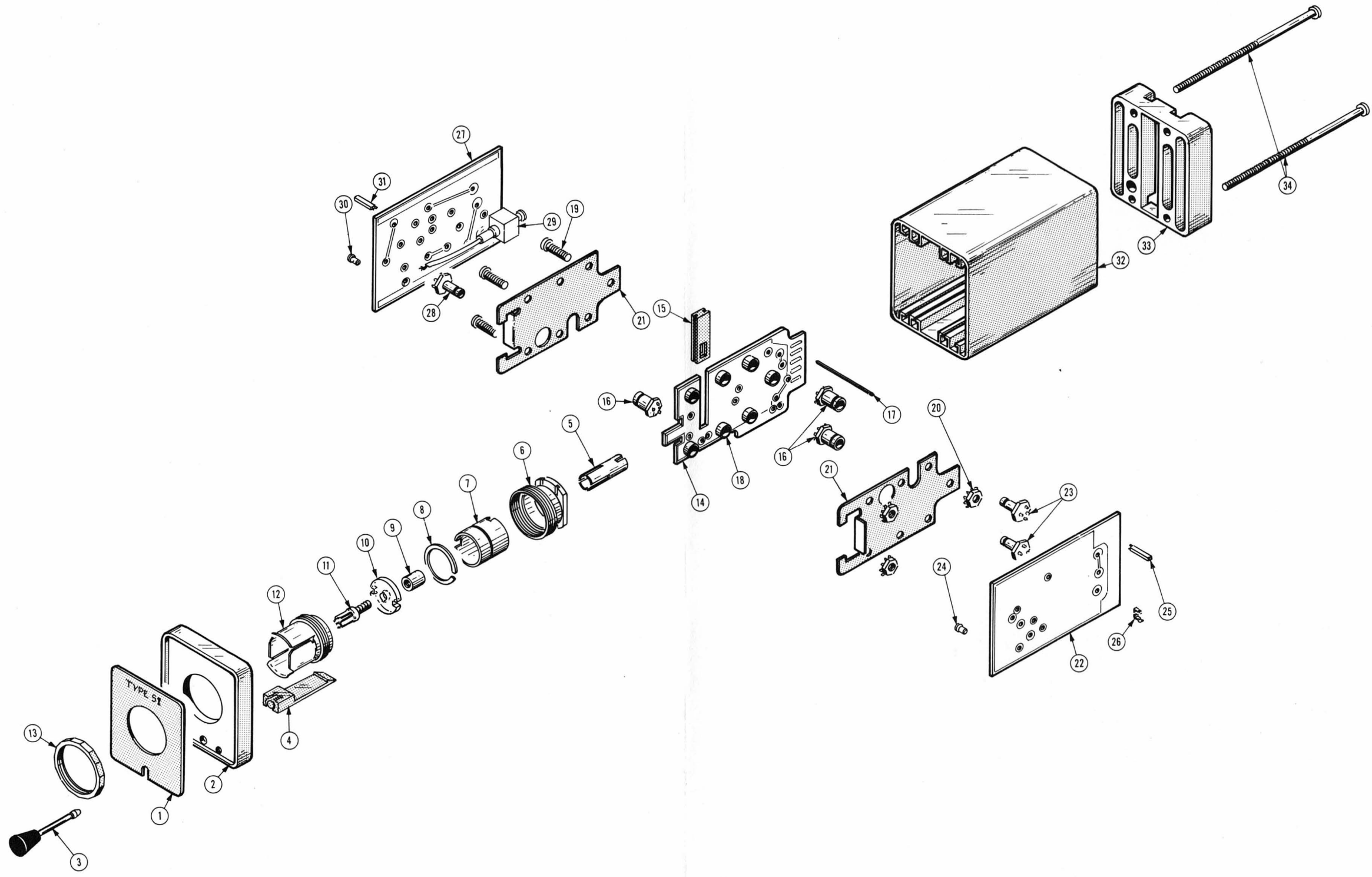

OPTIONAL ACCESSORIES (NOT SHOWN)

Fig. & Index No.	Tektronix Part No.	Serial/Model No.		Q t y	Description
		Eff	Disc		
				1 2 3 4 5	
	012-0124-00			1	CABLE, extender, 3 feet
	012-0125-00			1	CABLE, extender, 6 feet

FIG. 2 STANDARD ACCESSORIES

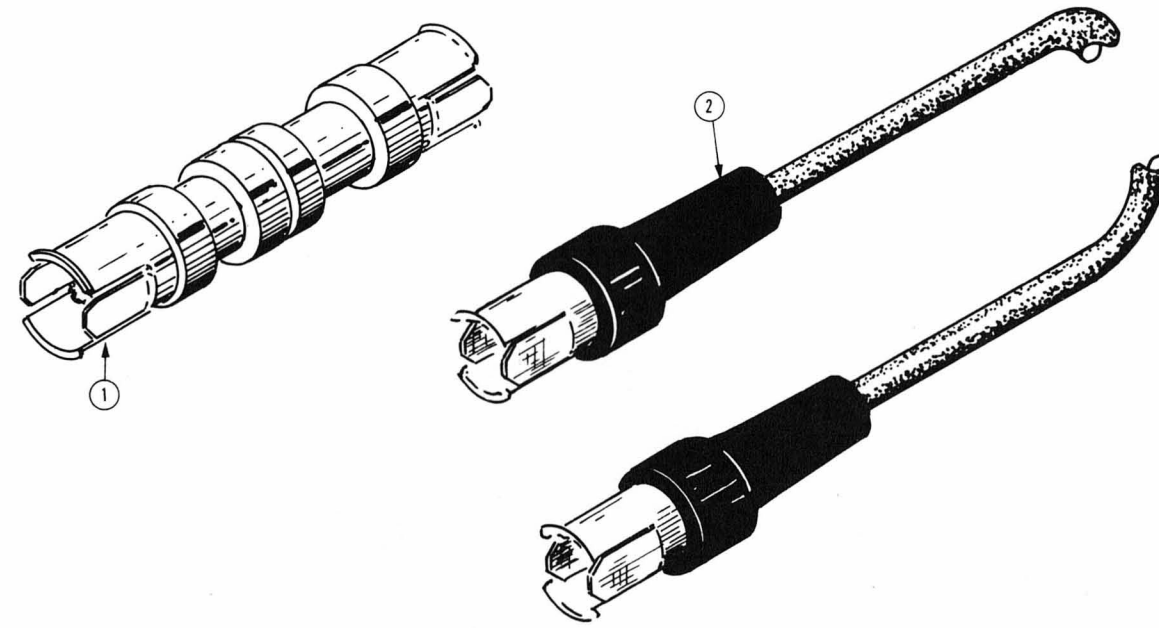

Fig. & Index No.	Tektronix Part No.	Serial/Model No.		Q t y	Description
		Eff	Disc		
				1 2 3 4 5	
2-1	017-0078-00			1	ATTENUATOR, 10X 50 Ω
-2	017-0512-00			1	CABLE, 5 ns delay w/GR connectors
	070-0763-00			2	MANUAL, instruction (not shown)

FIG. 2 ACCESSORIES