

Instructions

1240D1 INSTALLATION INSTRUCTIONS

1200 Series Logic Analyzers

INTRODUCTION

The 1240D1 9-Channel Acquisition Card should be installed only by a qualified service technician.

Compatibility. The 1240D1 is only compatible with the Tektronix 1240 Logic Analyzer. Do not attempt to install this card in any other product.

Service Information. Refer to the *1240 Logic Analyzer Service Manual* for all 1240D1 service information. These instructions only contain installation information.

Operator's Information. Refer to the *1240 Logic Analyzer Operator's Manual* for information on how to use the 1240D1 as part of a 1240 Logic Analyzer system.

DISASSEMBLY PROCEDURE

Installation of a 1240D1 card in a 1240 Logic Analyzer requires opening the 1240 to gain access to the 1240D1's possible locations and the application of certain simple rules about the relative locations of 1240D1 cards, 1240D2 (18-channel) cards, and empty slots. In some cases, you may need to access the power supply to change the position of the current limit jumper. Read all of the following cautionary material before opening the instrument. Install the acquisition cards as described in these instructions and double check your work before applying power.

Reassembly procedures are the reverse of the disassembly steps unless otherwise noted.

WARNING

Dangerous electric-shock areas inside the mainframe may be exposed when the covers are removed. Be sure the power is off and the power cord is disconnected before removing the covers. Disassembly procedures should only be attempted by qualified service personnel.

GENERAL PRECAUTIONS

- DO NOT attempt any disassembly or installation procedures if power is ON.
- DO NOT operate an instrument with the cabinet removed unless the front or rear of the instrument is raised off the working surface. When the instrument is in the service position (see Figure 3), position a fan to blow air into the left front of the mainframe (as you face the instrument). These procedures force air into the power supply area for cooling.

- DO NOT disconnect probes from the side of the 1240 by pulling on the cables; pull only on the plastic cable holders.
- DO NOT press or pull on components when manipulating circuit boards.

STATIC PRECAUTIONS

CAUTION

Static discharge can damage any semiconductor in this instrument.

Observe the following precautions to avoid static damage:

- Minimize handling of static-sensitive components.
- Transport and store static-sensitive components or assemblies in their original containers, or on a metal rail, or on conductive foam. Label any package that contains static-sensitive components or assemblies.
- Discharge the static voltage from your body by wearing a wrist strap while handling these components. Servicing static-sensitive assemblies should be performed only in a static-free work station by qualified service personnel.
- Nothing capable of generating or holding a static charge should be allowed on the work station surface.
- Keep component leads shorted together whenever possible.
- Pick up components by the body, never by the leads.
- Do not slide the components over any surface.

- Avoid handling components in areas that have a floor or work-surface covering capable of generating a static charge.
- Use a soldering iron that is connected to earth ground.
- Use only special anti-static suction type or wick type desoldering tools.

NOTE

Damage to electrical components may not be immediately apparent. Always follow the precautionary measures listed above when handling static-sensitive components.

TOOLS REQUIRED

- Magnetic screwdriver, 1/4 inch drive
- POZIDRIV-type bit #1
- POZIDRIV-type bit #2
- Allen wrench, 1/16 inch

REMOVING THE CABINET

1. Remove the six #6 pan-head screws holding the rear cabinet frame ring. Remove the frame ring.
2. Remove the two #6 pan-head screws on the bottom of the 1240 that secure the probe guide. Center the Test Pattern Generator sliding door and remove the probe guide.
3. Position the handle over the top of the 1240.
4. Slide the cabinet off toward the rear of the instrument.

CURRENT LIMIT ADJUSTMENTS

The 1240 power supply requires a jumper change when the configuration changes to *more than two* acquisition cards (any type). The jumper change allows the power supply to handle the increased demand for current.

No current limit adjustments are necessary if the 1240D1 to be installed is *not* the third acquisition card. Proceed to *Rolling the Card Cage*.

If this 1240D1 will be the third acquisition card, you will have to access the power supply to change the position of the current limit jumper. To access the power supply, remove the cabinet as previously described, then perform the following steps.

Removing the Rear Panel

1. Using the magnetic screwdriver, remove the four corner hex posts from the rear panel.
2. Remove the CONTRAST knob with the Allen wrench.
3. Remove the rear panel.

WARNING

A blinking neon lamp on the Power Supply Board, visible through a hole in the power supply cover adjacent to the warning label, indicates that a lethal voltage is present on that board. Wait for at least 15 minutes after power-down before accessing the Power Supply or related assemblies.

Removing the CRT Drive Board Bracket

To access the Power Supply, you must first remove the bracket that holds the CRT Drive Board.

4. Remove the ten #4 flat-head screws holding the bracket to the mainframe. The location of these screws is shown in Figure 1.
5. Unplug the grey ribbon cable from the top of the CRT Drive Board then remove the bracket from the mainframe.

Changing the Current Limit Jumper

6. J444 is located in the lower, center section of the Power Supply Board.
7. For three or four acquisition cards, connect the jumper to pins 1 and 2 of J444. (For one or two acquisition cards, the jumper is connected to pins 2 and 3.)
8. Reconnect the ribbon cable to the CRT Drive Board, then reattach the bracket to the mainframe.

ROLLING THE CARD CAGE

1. If you did not perform the current limit adjustments, remove the two hex posts on the card-cage side of the rear panel.
2. Remove the three #4 flat-head screws shown in Figure 2.
3. Roll the card cage to the upright service position. See Figure 3.
4. Remove the two #4 flat-head screws shown in Figure 3, then remove the circuit board guide. Be sure to replace the guide after installing the 1240D1 card.

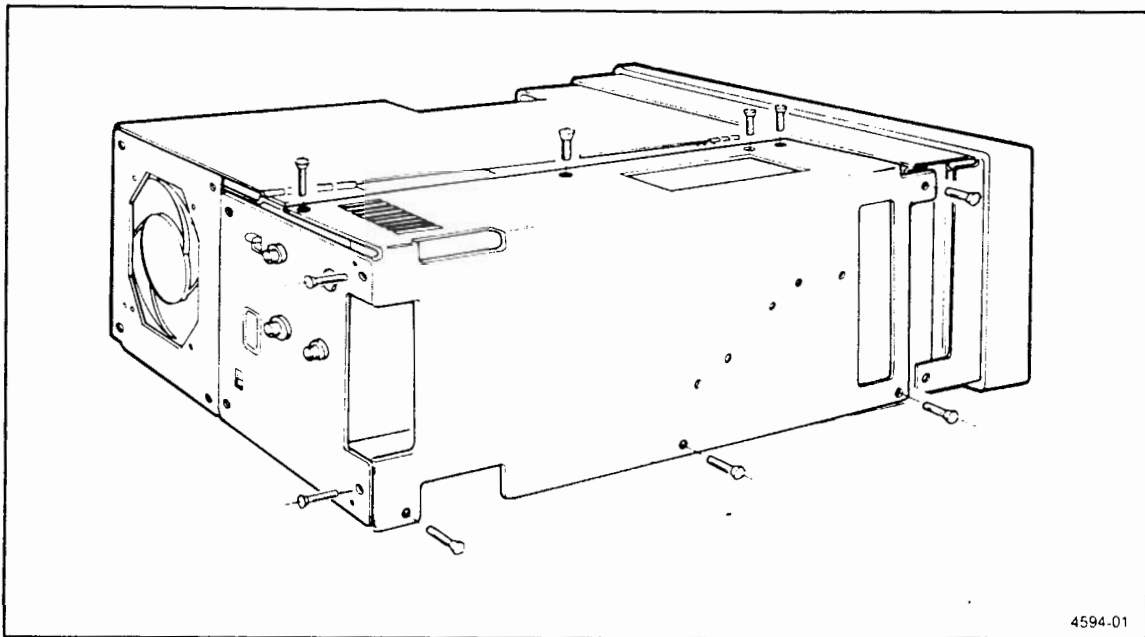

Figure 1. Location of screws for CRT Drive Board bracket removal. You only need to remove the CRT Drive Board bracket when it is necessary to access the Power Supply for current limit adjustments.

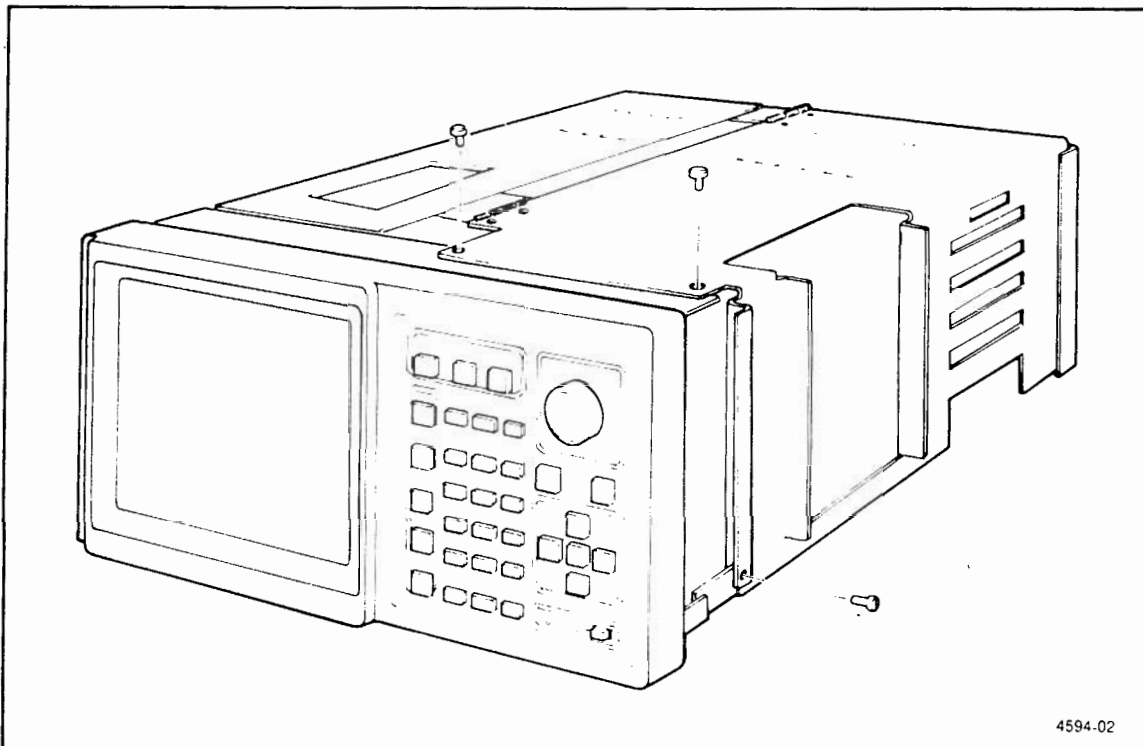
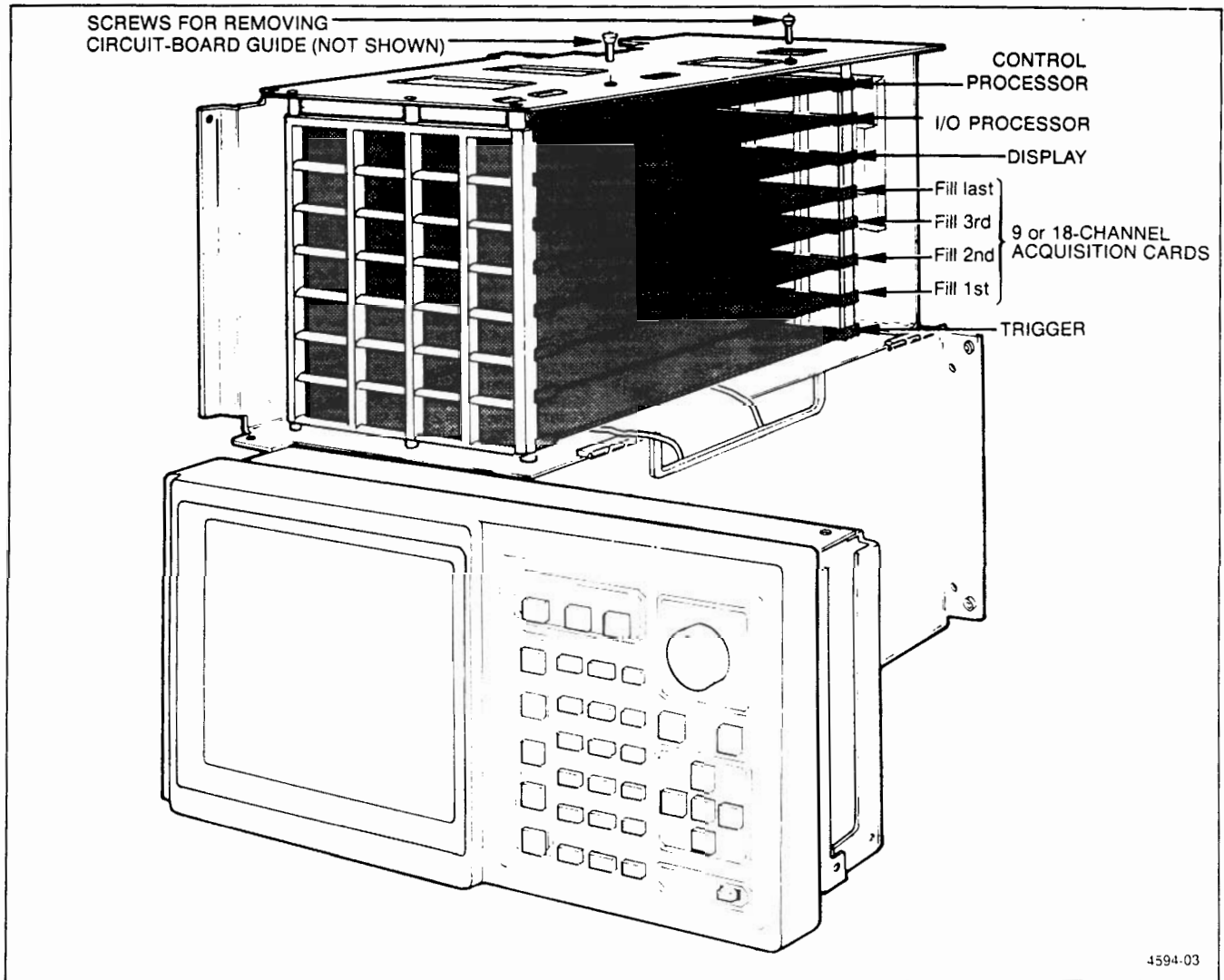

Figure 2. Location of three screws for card cage roll.



4594.03

Figure 3. View of the 1240 with the card cage in the service position. The circuit boards in the card cage are held in place by a circuit board guide (not shown in this figure). This guide must be removed before you can install a new acquisition card. To remove the guide, remove the two screws shown above. Install 1240D1 (9-channel) acquisition cards first, starting with the slot next to the Trigger Board. Fill any remaining slots with 1240D2 (18-channel) cards. Any empty slots should be next to the Display Board.

ACQUISITION CARD LOCATION RULES

Starting from the Trigger Board, fill adjacent slots with 1240D1s, then fill the remaining slots with 1240D2s (18-channel cards). All unused slots should be next to the Display Board. Refer to Figure 3.

Be sure to remove plastic probe-hole covers from the probe guide where necessary so that edge connectors on the back of the acquisition cards are accessible.

NOTE

If your instrument contains 18-channel cards, it will be necessary to remove them before installing new 9-channel cards in order to follow these rules.

To remove an acquisition card, press the two yellow board-ejector tabs outward until the card is free of the edge connector.