

TM 11-6625-2978-14

TECHNICAL MANUAL

**OPERATOR'S, ORGANIZATIONAL,
DIRECT SUPPORT AND GENERAL SUPPORT
MAINTENANCE MANUAL**

FOR

POWER SUPPLY PP-7549/U

(TEKTRONIX MODEL 1106)

(NSN 6130-01-018-1226)

HEADQUARTERS, DEPARTMENT OF THE ARMY

18 FEBRUARY 1982



5

SAFETY STEPS TO FOLLOW IF SOMEONE IS THE VICTIM OF ELECTRICAL SHOCK

1

DO NOT TRY TO PULL OR GRAB THE INDIVIDUAL

2

IF POSSIBLE, TURN OFF THE ELECTRICAL POWER

3

IF YOU CANNOT TURN OFF THE ELECTRICAL POWER, PULL, PUSH, OR LIFT THE PERSON TO SAFETY USING A WOODEN POLE OR A ROPE OR SOME OTHER INSULATING MATERIAL

4

SEND FOR HELP AS SOON AS POSSIBLE

5

AFTER THE INJURED PERSON IS FREE OF CONTACT WITH THE SOURCE OF ELECTRICAL SHOCK, MOVE THE PERSON A SHORT DISTANCE AWAY AND IMMEDIATELY START ARTIFICIAL RESUSCITATION

TECHNICAL MANUAL }
No. 11-6625-2978-14 }

TM11-6625-2978-14
HEADQUARTERS
DEPARTMENT OF THE ARMY
WASHINGTON, DC, 18 February 1982

**OPERATOR'S, ORGANIZATIONAL, DIRECT SUPPORT,
AND GENERAL SUPPORT MAINTENANCE MANUAL
FOR
POWER SUPPLY PP-7549/U
(TEKTRONIX MODEL 1106)
(NSN 6130-01-018-1226)**

REPORTING ERRORS AND RECOMMENDING IMPROVEMENTS

You can help improve this manual. If you find any mistakes or if you know of a way to improve the procedures, please let us know. Mail your letter, DA Form 2028 (Recommended Changes to Publications and Blank Forms), or DA Form 2028-2 located in the back of this manual direct to Commander, US Army Communications-Electronics Command, ATTN: DRSEL-ME-MQ, Fort Monmouth, NJ 07703.

In either case, a reply will be furnished direct to you.

TABLE OF CONTENTS

		Paragraph	Page
CHAPTER 1 .	INTRODUCTION		
SECTION I .	General	1-1	1-1
	II. Description and Data	1-7	1-1
	III. Safety Considerations	1-11	1-2
CHAPTER 2 .	SERVICE UPON RECEIPT AND INSTALLATION		
SECTION I .	Service Upon Receipt	2-1	2-1
	II. Installation	2-4	2-1
CHAPTER 3 .	OPERATING INSTRUCTIONS		
SECTION I .	Function of Controls and Connectors	3-1	3-1
	II. Operation and Inspection	3-3	3-1
	III. Battery Operation	3-5	3-1
CHAPTER 4 .	THEORY OF OPERATION		
SECTION I .	Circuit Description	4-1	4-1
	II. Operation Under Unusual Conditions	4-5	4-2
CHAPTER 5 .	MAINTENANCE		
SECTION I .	Troubleshooting	5-1	5-1
SECTION II .	Battery Service	5-3	5-1
CHAPTER 6 .	CALIBRATION		
SECTION I .	General	6-1	6-1
	II. Calibration During Maintenance	6-2	6-1

		Paragraph	Page
APPENDIX	A. REFERENCES		A-1
	B. MAINTENANCE ALLOCATION		
SECTION	I. Introduction	B-1	B-1
SECTION	II. Maintenance Allocation Chart.		B-3
	III. Tool and Test Equipment Requirements		B-4

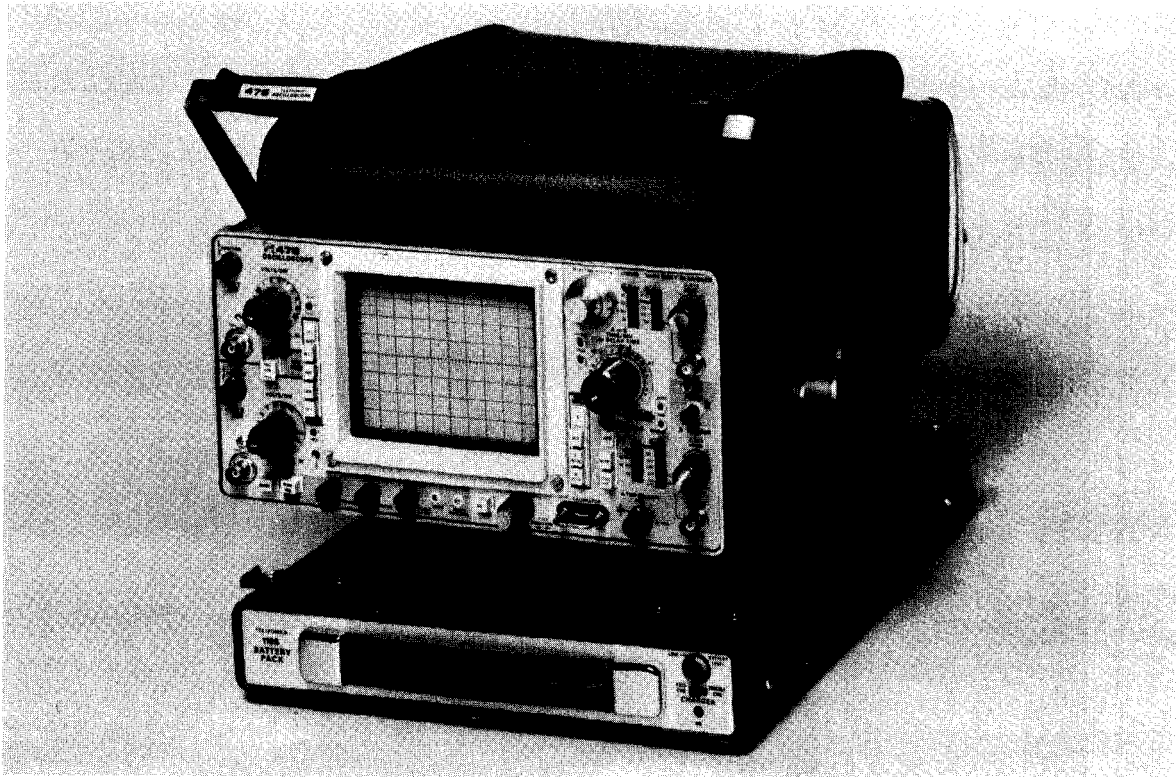

Figure 1-1. Power Supply PP-7549/U (1106 Battery Pack) Being Installed Under a Portable Oscilloscope.

CHAPTER I

INTRODUCTION

Section I. GENERAL

1-1. Scope

This manual describes Power Supply PP-7549/U (fig. 1-1) and provides instructions for its installation, operation, and maintenance. Power Supply PP-7549/U is the joint Army-Navy nomenclature and type number which has been applied to the commercially available Tektronix Model 1106 Battery Pack.

1-2. Index of Technical Publications

Refer to the latest issue of DA Pam 310-4 to determine whether there are new editions, changes, or additional publications pertaining to the equipment.

1-3. Maintenance Forms, Records, and Reports

a. Reports of Maintenance and Unsatisfactory Equipment. Department of the Army forms and procedures used for equipment maintenance will be those prescribed by TM 38-750, The Army Maintenance Management System.

b. Report of Packaging and Handling Deficiencies. Fill out and forward SF 364 (Report of Discrepancy (ROD)) as prescribed in AR 735-11-2/DLAR 4140.55/NAVMATINST 4355.73/AFR 400-54/MCO 4430.3E.

c. Discrepancy in Shipment Report (DISREP) (SF 361). Fill out and forward Discrepancy in Shipment Report (DISREP) (SF 361) as prescribed in AR 55-38/NAVSUPINST 4610.33B/AFR 75-18/MCO 4610.19C/DLAR 4500.15.

1-4. Reporting Equipment Improvement Recommendations (EIR)

If your Power Supply PP-7549/U needs improvement, let us know. Send us an EIR. You, the user, are the only one who can tell us what you don't like about your equipment. Let us know why you don't like the design. Tell us why a procedure is hard to perform. Put it on an SF 368 (Quality Deficiency Report). Mail it to Commander, US Army Communications-Electronics Command, ATTN: DR-SEL-ME-MQ, Fort Monmouth, NJ 07703. We'll send you a reply.

1-5. Administrative Storage

Administrative storage of equipment issued to and used by Army activities will have preventive maintenance performed in accordance with the PMCS charts before storing. When removing the equipment from administrative storage the PMCS should be performed to assure operational readiness. Disassembly and repacking of equipment for shipment or limited storage are covered in paragraphs 2-1 and 2-2.

1-6. Destruction of Army Electronics Materiel

Destruction of Army electronics materiel to prevent enemy use shall be in accordance with TM 750-244-2.

Section II. DESCRIPTION AND DATA

1-7. Purpose and Use

Power Supply PP-7549/U is a dc power source for operating portable Oscilloscope OS-261/U (Tektronix Model 475 Option 7) away from ac power sources. Power Supply PP-7549/U is sold commercially as a Tektronix, Model 1106 Battery Pack. Power Supply PP-7549/U is also referred to as the battery pack throughout this manual.

1-8. Description

Power Supply PP-7549/U is a self-contained portable battery pack equipped with a dc cable for connecting to an oscilloscope allowing operation away from ac power recepticals. It also has an ac cable

which enables connection to an ac circuit for recharging.

1-9. Use Option

a. The separate battery pack capability permits a choice of battery operation or ac line operation. During charging of the battery pack, the oscilloscope may be operated from the ac line without detaching the battery pack. The oscilloscope may be detached from the battery pack, while it is charging, and used elsewhere with either another battery pack or ac line. The battery pack and oscilloscope may be separated easily and quickly for carrying ease.

b. Refer to the oscilloscope technical manual for information regarding input power switch position when changing to or from battery pack operation.

1-10. Specifications

a. *AC Requirements.* Ac power source is required only for battery charging. Standard instrument: 100 to 132 Vac or 200 to 264 Vac, 50 to 400 Hz. Standard instrument with an internal connection change: 90 to 120 Vac or 180 to 240 Vac, see the maintenance section of this manual for further information 50 to 400 Hz. Power line consumption is 40 watts maximum at 115 Vac, 60 Hz.

b. *Power Output.* 22 to 24 Vdc for 7 ampere-hours. 5 A maximum.

c. *Battery Operating Time.* Approximately 140 watt-hours from fully-charged batteries.

d. *Battery Charge Time.* 14 to 16 hours (0° C to 40° C).

e. *Temperature.* Operating, 0° C to 40° C. 0° C to 40° C will not noticeably reduce the battery capacity. Storage outside this range will reduce battery efficiency and capacity. Non-operating; with batteries -40° C to +60° C; without batteries, -55° C to +75° C.

f. *Physical.* Weight is 16 pounds. 11.5 inches wide. 17.0 inches long, including feet and handle. 2.6 inches high, including feet. Combined height of battery pack and oscilloscope is approximately 8.4 inches.

Section III. SAFETY CONSIDERATIONS

1-11. Charging

The instrument is intended to be operated from a single-phase ac power source having one current-carrying conductor (the Neutral Conductor) at ground (earth) potential. Operation from power sources where both current-carrying conductors are live with respect to ground (such as phase-to-phase

on a three-wire system) is not recommended, since only the Line Conductor has over-current (fuse) protection within the instrument.

1-12. Power Cord Conductor Identification

Identification of power cord conductors is contained in table 1-1.

Table 1-1. Power Cord Conductor Identification

Conductor	Color	Alternate Color
Ungrounded (Line)	Brown	Black
Grounded (Neutral)	Blue	White
Grounding (Earthing)	Green-Yellow	Green-Yellow

1-13. AC Power Cord

The instrument has a three-wire power cord with a three-terminal polarized plug for connection to the power source and safety-earth. The ground (earth) terminal of the plug is directly connected to the instrument frame. For electric-shock protection, insert this plug only in a mating outlet with a safety earth contact.

1-14. Operating

a. The potential at the chassis (frame) of the battery pack is established by the oscilloscope being powered through the safety-earth conductor system. For electric-shock protection, connect the oscilloscope cabinet (frame) to a ground (earth) reference.

b. If the battery pack ac power cord is connected to a correctly-wired ac power source, an additional shock protection circuit is established through the safety-earth conductor system.

CHAPTER 2

SERVICE UPON RECEIPT AND INSTALLATION

Section I. SERVICE UPON RECEIPT

2-1. Packaging Data

a. Power Supply PP-7549/U may arrive packed for either domestic or overseas shipment.

b. When Power Supply PP-7549/U is packed for overseas shipment it is placed in a lightweight packing material and is placed in a corrugated carton. The carton is sealed with gummed tape. The boxed equipment is then placed in a moisture-vaporproof barrier, which is heat-sealed, and this package is placed in a waterproof corrugated carton. The technical manuals are placed under the lid and the carton is sealed with waterproof tape. The packaged battery pack is placed in a wooden shipping container with a waterproof case liner. The wooden container is reinforced with flat metal straps.

2-2. Unpacking

a. For unpacking overseas shipment equipment, proceed as follows:

(1) Cut the metal straps with a suitable cutting tool, or twist them with pliers until the straps break. Remove the straps.

(2) Remove the nails from the top and one side of the wooden case. Do not attempt to pry off the sides and top. Such action may damage the equipment.

(3) Remove the corrugated filler from the packing case and lift the packaged equipment out of the case.

(4) Open the outer corrugated carton and break the sealed moisture-vaporproof barrier. Lift out the inner corrugated carton.

(5) Open the inner corrugated carton and remove the battery pack. Read and observe the charging instructions fully before connecting the battery pack to an oscilloscope.

b. The battery pack may be received in domestic packing cases. The instructions given in *a* above, also apply to unpacking domestic shipments. If heavy wrapping paper has been used, remove it carefully and take out the battery pack.

2-3. Check Unpacked Equipment

a. Inspect the equipment for damage incurred during shipment. If the equipment has been damaged, report the damage on SF 964 (para 1-3b).

b. Check the equipment for completeness against the packing slip.

Report all discrepancies in accordance with paragraph 1-3. The equipment should be placed in service even though a minor assembly or part that does not affect proper functioning is missing.

c. Check to see if the equipment has been modified. Modified equipment will have the MWO number on the front panel near the nomenclature plate. Check also to see whether all currently applicable MWO's have been applied. (Current MWO's are listed in DA Pam 310-4).

d. After the equipment has been thoroughly checked, clean with a soft cloth.

Section II. INSTALLATION

2-4. Attaching The Battery Pack

a. The battery pack is equipped with four permanently attached clamps that are designed to fit and attach to the feet of the portable Oscilloscope OS-261 (Tektronix Model 475 Option 7). Set the oscilloscope on the battery pack and observe that the oscilloscope feet seat properly in the clamps. Press the moveable part of the clamp inward until a positive fit is accomplished.

b. The dc power cord attached to the battery pack is to be plugged into the dc socket of the oscilloscope. Refer to chapter 3 prior to placing the battery pack into operation.

c. The ac power cord to the battery pack is not used while the battery pack is in operation. Store this ac cord in a method so that it will not incur damage during movement of the oscilloscope and battery pack from one working area to the next.

d. It may be advantageous to use the battery pack and the oscilloscope as separate units as each item is equipped with its own carrying handle. With care, the two units may be carried short distances by two persons without disconnecting the dc power cord while still in the operational mode, thus realizing the full portability of these two units.

CHAPTER 3

OPERATING INSTRUCTIONS

Section I. FUNCTION OF CONTROLS AND CONNECTORS

3-1. Battery Level

Meter indicates the approximate state of charge of the batteries while under load.

3-2. Charger

a. Mode Switch.

(1) *Full.* Permits the maximum safe charging rate. Charge rate should be changed to the trickle-charge rate when the batteries have received a full charge.

(2) *Trickle.* Reduces the charging rate to main-

tain fully-charged batteries.

b. ON Position. Lamp indicates charger is on. Charging occurs as long as the battery pack is connected to the ac power line.

c. Line Selector. Select 115 Vac or 230 Vac operation.

d. DC Output (Attached Cord). Connects to the oscilloscope external dc input.

e. AC Input. Allows ac operation of the battery charger circuit only, as long as the ac line is connected.

Section II. OPERATION AND INSPECTION

3-3. First-Time Operation

The instrument may be operated with less than fully charged batteries. For first-time operation, however, charge the batteries at the full-charge rate for 14 to 16 hours.

3-4. Attaching the Battery Pack

Attach the battery pack to an oscilloscope with Option 7 as follows (see fig. 1-1):

a. Open the latches on the battery pack by pulling them outward. Set the oscilloscope on top of the battery pack with the feet in the holes in the latches. Push the latches in until they lock in the feet of the

oscilloscope. Check each corner to verify that each foot has been latched to the battery pack.

b. Set the oscilloscope for 24 Vdc operation and connect the battery pack output to the oscilloscope (Option 7) dc input. Turn the oscilloscope on. Check that the battery pack powers the oscilloscope. Observe the BATTERY LEVEL meter. The meter reading is only indicative of the remaining charge if the battery pack is powering an oscilloscope. Under no-load conditions, the battery pack will read full, even if it is almost discharged.

c. Connect the oscilloscope frame to a ground (earth) reference before using.

Section III. BATTERY OPERATION

WARNING

The nickel-cadmium (NiCd) cells used in this instrument are capable of delivering a large amount of current in a short time. Care must be taken not to short-circuit the cells. The battery pack is fused at 6 amperes.

3-5. Operating Time

a. Battery operating time depends on the load

selected and the charge-discharge temperatures. Optimum charge and discharge is obtained when the batteries are operating at temperatures between 20° C to 30° C. Relative capacities for other temperatures are shown in table 3-1. Battery pack discharge curves are given in figure 3-1.

b. Optimum operating time is obtained by having the battery pack vertical (handle on top) during battery charging.

Table 3-1. Typical Battery Charge Capacity (referenced to charge-discharge at +20° C to +30° C)

Charge Temperature	Operating Temperature		
	-15° C	+20° C to +30° C	+55° C
0° C	40%	60%	50%
+20° C to +30° C	65%	100%	85%
+40° C	40%	65%	55%

c. The approximate battery pack operating time may be roughly estimated using figure 3-1. For individual oscilloscope times see the Option 7

Specification portion of the oscilloscope technical manual.

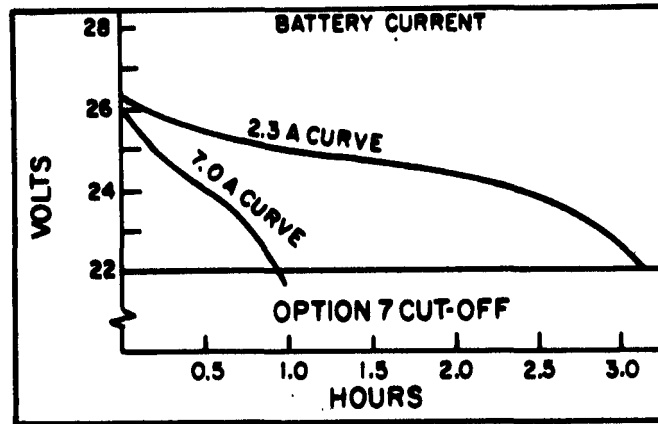

EL6RK002

Figure 3-1. Typical Battery-Pack Discharge Curves.

NOTE

High discharge rates or high ambient temperatures may raise the battery temperature enough to lower their 140 watt-hour capability.

3-6. Battery Discharge

Extensive discharge of the batteries may cause one or more of the cells to reverse polarity. Repeated reversal shortens the useful life of the batteries. The oscilloscope with the Option 7 has a circuit to cut off its inverter when the external dc source drops below approximately 22 Vdc. This prevents the battery from going into deep discharge.

3-7. Battery Charge

a. A thermal cutout in the battery pack protects the batteries from overheating during charge time. The batteries normally become warmer as they reach full charge potential. If the temperature surrounding the batteries exceeds the safe operating level, a thermal cutout switches the charge rate from 620 milliamperes full-charge to the 60-milliamperere trickle-charge rate. When the temperature returns to a safe operating level, the thermal cutout returns the charge rate to the 620-milliamperere level.

The batteries may be damaged by over-charging for long periods (in excess of 24 hours). Repeated over-charging shortens the useful life of the batteries.

b. During normal usage or storage, each battery cell in the battery pack acquires a slightly different charge characteristic. To provide the best overall operation and maximum operating life, the charge on the individual battery cells should be equalized periodically. This can be done without damage to the battery cells by charging the batteries at the full-charge rate for 24 hours. Charging should be done after every 15 charge-discharge cycles or every 30 days, whichever occurs first.

c. Once the batteries are fully charged, change the mode switch to trickle charge if the battery pack is to remain connected to the ac line. This maintains fully-charged batteries and prevents overcharging.

3-8. Battery Pack Storage

a. The batteries used in the battery pack should be stored in a charged condition. For best shelf life, when storing the battery pack for long periods of time, remove fuse F131 (which may be stored by placing it in the dc power cord clip on the rear panel). Fully recharge the batteries about every three months.

b. Charge retention characteristics of nickel-cadmium batteries vary with the storage temperature and humidity. The battery pack may be stored at ambient temperatures between -40°C and $+60^{\circ}\text{C}$ without damage, either in the instrument or as a separate unit. The self-discharge rate increases with an increase in ambient temperature. For example, cells stored at $+20^{\circ}\text{C}$ will lose about 50% of their stored charge in three months, but when stored at $+50^{\circ}\text{C}$, they will be almost completely self-discharged in only one month. High humidity also increases the rate of self-discharge.

3-9. Maintenance

Additional data regarding maintenance and repair of the battery pack and the NiCd cells can be found in the maintenance section of this manual.

310. Battery Charge Level

a. Meter indication of battery charge level may be false during the first several minutes of battery operation. This is due to a battery characteristic.

b. When the battery pack is turned on, a residual battery charge may give a meter indication of a high state-of-charge even though a low, partial charge is all that remains. The battery pack may operate several minutes, under load, before this partial charge is depleted.

c. This characteristic may show up after the battery pack has been discharged and the instrument turned off. It may also show up after the instrument has been stored in temperatures significantly below 25°C , then brought to room temperature for operation.

d. If unsure of the state of the battery charge, recharge at the proper temperature for the full recharge time given in the battery operation section.

CHAPTER 4

THEORY OF OPERATION

Section I. CIRCUIT DESCRIPTION

4-1. General

a. The battery pack provides a 24 Vdc power source. The charger circuit will charge, at either full-charge or trickle-charge rates, as long as the battery pack is connected to the correct ac line. The meter circuit is always on. The output voltage is always available at the DC OUT plug. The batteries may be disconnected from the meter and charger circuitry by removing fuse F131.

b. Refer to the complete schematic in chapter 6 throughout the following circuit description.

4-2. Battery Charger Circuit

a. From the secondary of transformer T101, ac voltage is applied to full-wave bridge rectifier CR115. The rectified voltage goes to filter C115 and through CR121 to resistor R121 and transistor Q124. VR123 sets the bias for Q124. This bias is about 5.6V across the R123 and the emitter-base junctions of Q124, a Darlington transistor. The drop across the two emitter-base junctions reduces this voltage to about 4.3 V across R123.

b. In parallel with R123 is the series combination of CR125, S125, S130, and R131. The charge rate switch S130 is shown in the FULL CHG position (closed). Under normal battery temperatures, thermal cut-out S125 is closed and the 4.3 V is across R131 (in series with CR125). This limits the charge current to about 620 milliamperes.

c. Battery temperature rises as the batteries reach full charge. S125 opens, removing resistor R131 from the circuit. The charging current is now limited to about 60 milliamperes by the 4.3 V being applied only across R123. The same current reduction occurs when the charge rate switch (S130) is set to TRICKLE CHG (open).

4-3. Charger Circuit Protection

a. Power dissipated by Q124, in the full-charge mode, is reduced for high line or low battery conditions by the circuitry involving C117, CR111, CR112, R125, and T101.

b. At low line, CR111 and CR112 are reverse biased. An increase in line voltage increases the potential from the -DC OUT line to the collector of Q124 and also to CR112 and CR111. Q124 provides a constant current to a fixed load (R123 and R131). The increased potential, therefore, appears across Q124, increasing its dissipation.

c. At some point the increased line voltage causes CR111 and CR112 to conduct. This point is determined by the taps on T101. Once CR111 and CR112 conduct, they maintain a voltage at the plus side of C117 that is about 70% of the voltage at the plus side of C115 (with respect to the -DC OUT line). As the voltage across C117 increases, current through R125 increases. There is a corresponding decrease in current supplied by Q124. This current reduction in Q124 decreases the power dissipated in Q124. Since the current through R125 is supplied from a lower voltage source than is the current through Q124, there is a reduction in total power.

d. A low charge on the batteries will have the same effect on the circuit as an increase in line voltage. Batteries with a low charge and with a high ac line may receive nearly all of the charging current through CR111, CR112, and R125.

e. CR125 prevents the current, during high line conditions, from bypassing the charge rate switch when it is in the TRICKLE CHG mode. CR 121 prevents C115 from charging through Q124. This situation can exist if the battery pack has been off for a long time, a dead battery is replaced, F131 is replaced, or a similar condition exists that permits C115 to discharge, then apply voltage across the +DC OUT line.

4-4. Meter Circuit

The voltage reference for the meter circuit is set by R127 and VR131. The other side of the meter is connected to voltage divider R128, R133, and R136. R133 is set for a meter reading at the junction of the red and green portions of the meter scale (a reading at the left end dot for early SN instruments).

Section II. OPERATION UNDER UNUSUAL CONDITIONS

4-5. Operation in Arctic Climates

Subzero temperatures and climatic conditions associated with cold weather may hamper the efficient operation of electronic equipment. Instructions and precautions for operation under such adverse conditions follow:

a. Keep the equipment warm and dry. If the equipment is not kept in a heated enclosure, construct an insulated box for its protection.

b. Make certain the equipment has been warmed up sufficiently before use. This may take 15 to 30 minutes, depending on the temperature of the surrounding air.

c. When equipment which has been exposed to the cold is brought into a warm room, it will sweat until it reaches room temperature. When the equipment has reached room temperature, dry it thoroughly.

4-6. Operation in Tropical Climates

In tropical climates, electronic equipment may be installed in tents, huts or, when necessary, in underground dugouts. When equipment is installed below ground, and when it is set up in swamp areas, danger of moisture damage is more acute than normal in the tropics. Ventilation is usually very poor, and the high relative humidity causes condensation on the equipment whenever its temperature becomes lower than the ambient air. To counteract this condition, place lighted electric bulbs under the equipment.

4-7. Operation in Desert Climates

The main problem with electronic equipment in desert areas is the large amount of sand and dust that lodges in the moving parts and mechanical assemblies. Cleaning and servicing intervals should be shortened according to local conditions.

CHAPTER 5

MAINTENANCE

Section I. TROUBLESHOOTING

5-1. General

The first step in servicing a defective battery pack is to sectionalize the fault. Sectionalization means tracing the fault to the major circuit responsible for the abnormal operation. The second step is to localize the fault. Localization means tracing the fault to a particular stage or network within one of the major circuits. The third step is to isolate the fault. Isolation means tracing the fault to the defective part responsible for the abnormal condition. Some faults, such as burned-out resistors, arcing and shorted transformers, can often be located by sight, smell, and hearing. The majority of faults, however, must be isolated by checking voltages and resistances.

5-2. Component Sectionalization, Localization, and Isolation

Listed below is a sequence of tests arranged to reduce unnecessary work and aid in tracing the trouble to a specific component.

a. Visual Inspection. Through inspection alone, the trouble may frequently be discovered or the circuit in which the trouble exists may be determined. This inspection helps to avoid additional damage to the equipment as a result of improper servicing methods.

b. Intermittents. It is possible that some external connections may cause the trouble. Test wiring for loose connections and move wires and components with an insulated tool. This may indicate the location of a faulty connection or component.

c. Voltage Checks. Refer to figures 6-2, 6-3, and 6-4 for troubleshooting voltage checks, symbols, and schematic diagram.

Section II. BATTERY SERVICE

5-3. Tools and Test Equipment Required

The following is a list of common tools and test equipment required for general support maintenance.

a. Multimeter ME-451/U, NSN 6625-01-060-6804.

b. Battery Charger PP-6241/U, NSN 6130-00-106-6445.

c. Tool Kit, Electronic Equipment TK-100/G, NSN 5180-00-605-0079.

5-4. Batteries

a. The battery pack contains twenty 1.25 V Nickel-Cadmium (NiCd) cells, in groups of four, strapped together. Background information regarding these cells is given in chapter 3, section III battery operation and should be read before any servicing is performed on the battery pack.

b. If one group of cells is defective and fails while the rest of the battery pack is still quite new, that group may be replaced without undue concern. The Tektronix Field Representative or Office should be consulted before cells are replaced, if the warranty is still in effect.

c. Gas evolution and recombination takes place

during battery charging. This creates a pressure within the cells which they normally can withstand. If a cell becomes defective, or a circuit failure causes the recommended charge rate to be exceeded, excessive pressure builds up. The pressure may rupture a relief vent, exhausting the gas. This action may shorten the life of the cell, and will coat the surrounding areas with a corrosive substance.

5-5. Battery Removal

Remove the six screws from the sides of the battery pack. Remove the cover. Remove fuse F131. Remove the two screws from the battery clamps. Unsolder the wires at the batteries.

5-6. Cell Replacement

a. When necessary, a group of four cells can be removed and replaced by cutting the straps that connect the two ends of the cell group to the pack, and soldering a new group of four cells. Single cell replacement should not be attempted. The cell type specified must be used. Other types may not function properly. They may prove to be a hazard to the instrument and to personnel. Operating time or temperature performance may be degraded. The battery

pack should be charged for 24 hours after cells are replaced.

b. All cells in the battery pack should be made by the same manufacturer. Include this information, with the other information required, when ordering replacement cells.

5-7. Line voltage Selection Wiring

a The battery pack can be wired to accept a

variation in input voltage as may exist in certain conditions or geographical areas. The wires on transformer T101 may be changed to accept line variation. Proper wiring of the input will result in satisfactory battery pack charging.

b. Refer to figure 5-1 for line voltage selection wiring. For nominal 115 Vat, use the 100 to 132 VAC diagram. For nominal 105 Vat, use the 90 to 120 VAC diagram.

100 TO 132 VAC

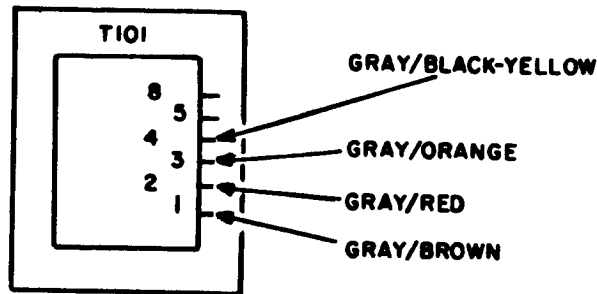

A.

90 TO 120 VAC

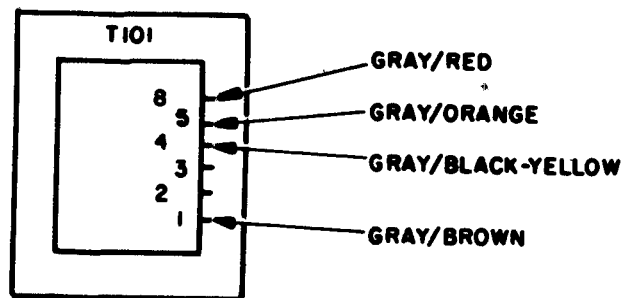

B.

EL6RK003

Figure 5-1. Line Voltage Section Wiring.

CHAPTER 6

CALIBRATION

Section I. GENERAL

6-1. Terms and Definition

a. Calibration, in accordance with maintenance practices, is the checking of voltages, current, resistances, etc., through each section or stage, and the adjusting and alignment of variable components within each section or stage. It is almost always necessary to perform this type of calibration while the equipment is being electrically repaired or as parts are being replaced. Common maintenance test equipment is used for this type of calibration.

b. Calibration, in accordance with AR 750-25-1 (US Army Calibration System), is a periodic check of the total accuracy of each parameter as compared to calibrated standards at a ratio of 4 to 1. Upon completion of this type of calibration a Department of the Army DA Label 80 is affixed to the accepted unit. All information regarding calibration requirements for the maintenance of Army materiel is contained in TB 43-180 and TM 38-750.

Section II. CALIBRATION DURING MAINTENANCE

6-2. Battery Pack Disassembly

a. For calibration during maintenance, remove the six screws from the sides of the battery pack and

lift the cover.

b. For further mechanical disassembly see the exploded view in figure 6-1.

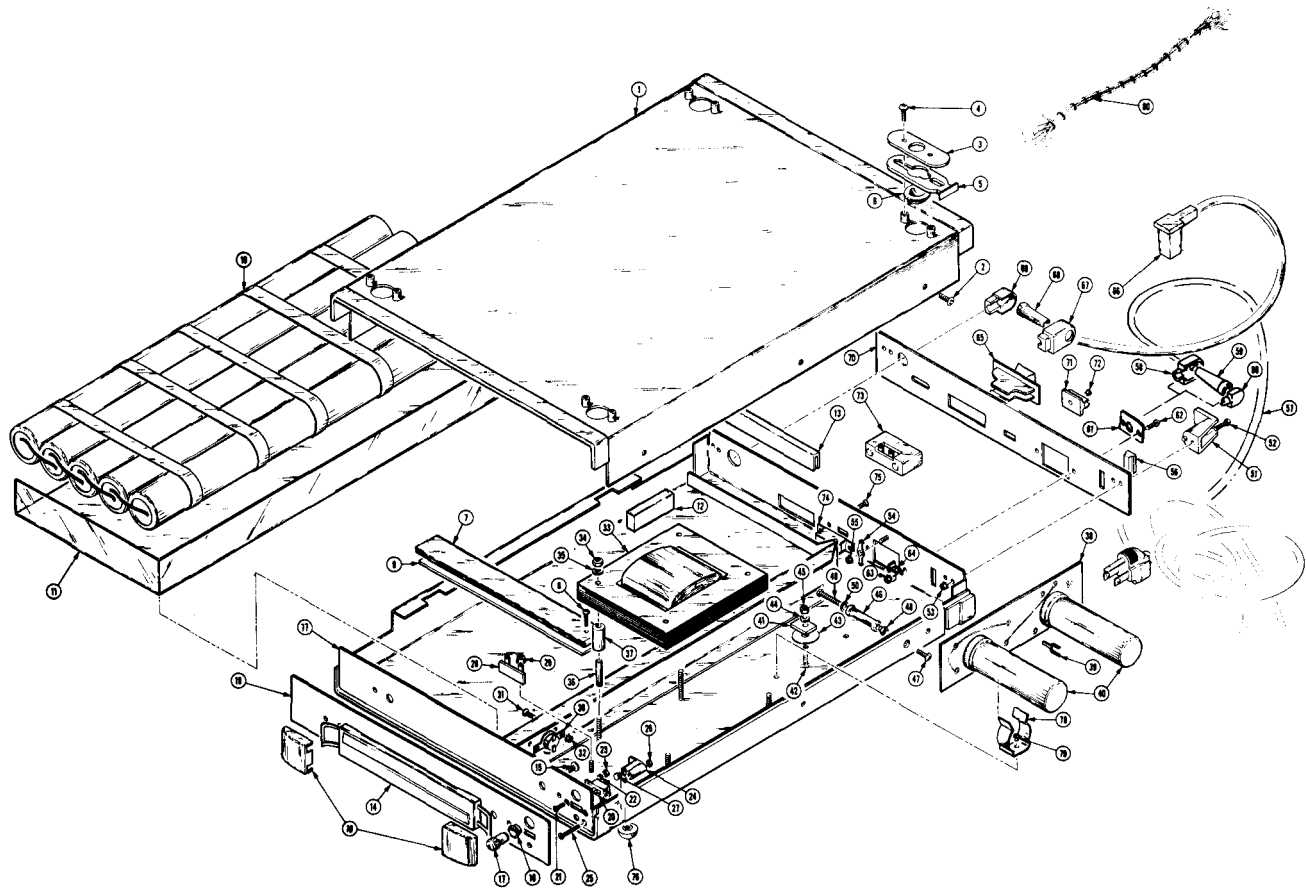

Figure 6-1. Battery Pack PP-75/U, Exploded View.

WARNING

Dangerous potential and high current capabilities exist at several points. Disconnect power cord, remove fuse F131, and unsolder batteries before replacing parts.

6-3. Equipment Required

DC Milliammeter: 620 mA and 60mA. Voltmeter: 20,000 Ω /VDC and 5,000 Ω /VAC **multimeter**. Variable DC Power Source: 21 to 24 V at 10 mA.

NOTE

The battery pack is calibrated at the factory using a power supply permitting ac-

curate setting of the meter zero. Because this type of power supply may not be available, an alternate method is given. The accuracy of the equipment required depends on how critically the user wants the meter zero to coincide with the cut-off point in the Option 7 circuitry.

6-4. Calibration Procedure

a. Charge.

(1) Remove fuse F131, (figure 6-2). Connect the ammeter across the terminals for F131. Connect the battery pack to the correct ac line. Set the mode switch to FULL CHG.

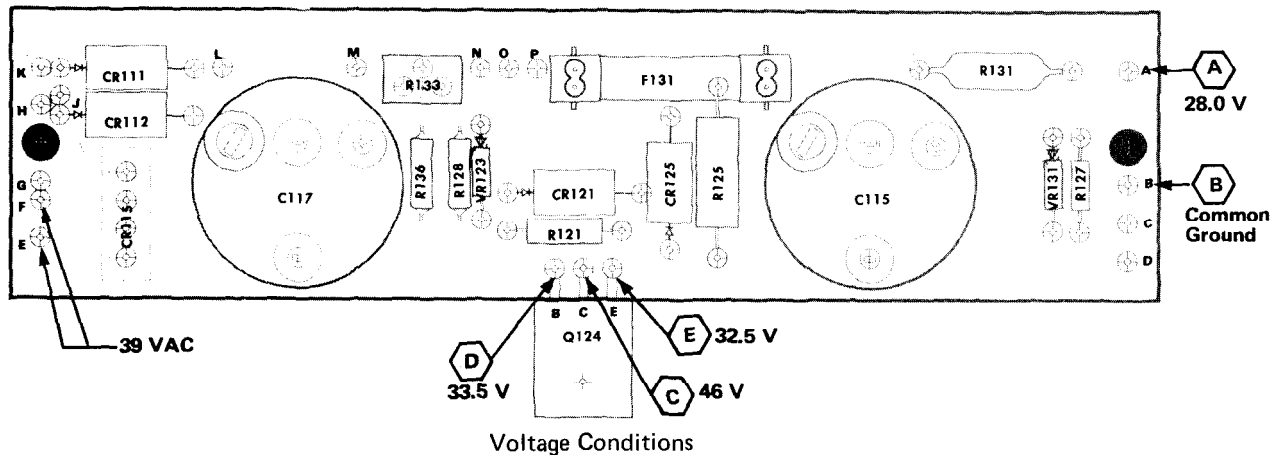

Voltmeter: 20,000 $\Omega/\zeta\Delta X$ and 5,000 $\Omega/\zeta AX$ multimeter.

Voltage readings will vary with line voltage and battery charge level.

Battery charged

Line Selector: Correct line voltage

Mode Switch: FULL CHG

Figure 6-2. Battery Pack PP-7549/U, Circuit Board, with Test Voltages and Conditions.

(2) Current should be approximately 620 mA.

(3) Change mode switch to TRICKLE CHG.

(4) Current should be approximately 60 mA.

b. Zero Adjust.

(1) Disconnect the battery pack from the ac line. Disconnect the external milliammeter but do not install F131. Connect a 23 V power source to the DC OUT connector (for SN below B022417 use a 22 V source).

(2) Battery level meter should read near the

junction of the red and green portions of the scale (or near the left end dot for SN below B022417).

(3) Adjust Meter Level (R133) (fig. 6-2) for a reading at the junction of the red and green portions of the scale (for SN below B022417 adjust R133 for a meter reading at the left end dot).

(4) Remove the dc power source and install fuse F131.

(5) Reassemble the battery pack in the opposite manner as disassembled in paragraph 6-2.

CIRCUIT BOARD ILLUSTRATION, DIAGRAM, AND PARTS LISTS

Symbols

Electrical components shown on the diagrams are in the following units unless noted otherwise:

Capacitors = Values one or greater are in picofarads (pF).

Values less than one are in microfarads (μF).

Resistors = Ohms (Ω).

Symbols used on the diagrams are based on USA Standard Y32.2-1967.

Logic symbology is based on MIL-STD-8068 in terms of positive logic. Logic symbols depict the logic function performed and may differ from the manufacturer's data.

The following special symbols are used on the diagrams:

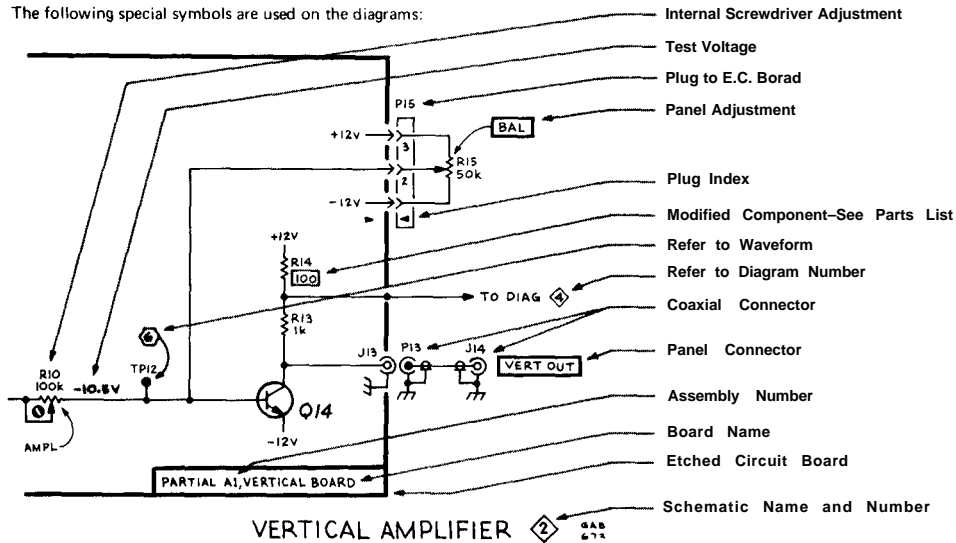
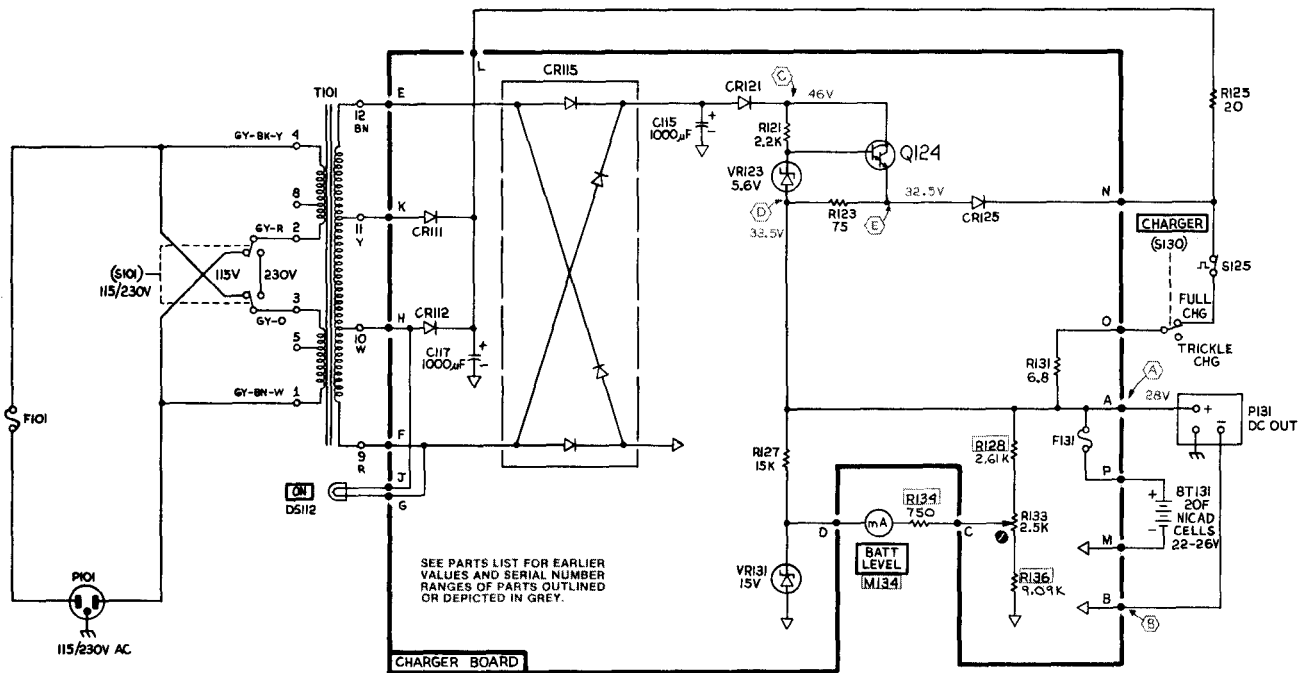

Figure 6-3. Battery Pack PP-7549/U, Vertical Amplifier Schematic with Explanation of Electrical Symbols.



NOTE:
 ↓ DENOTES COMMON
 ▽ NEGATIVE RETURN

Figure 6-4. Battery Pack PP-7649/U, Schematic Diagram.

APPENDIX A

REFERENCES

DA Pam 310-4	Index of Technical Publications.
TB 43-180	Calibration Requirements for the Maintenance of Army Materiel.
TB 43-0118	Field Instructions For Painting and Preserving Electronics Command Equipment Including Camouflage Pattern Painting of Electrical Equipment Shelters.
TM 11-6130-351-14	Operator's, Organizational, Direct Support, and General Support Maintenance Manual Including Repair Parts and Special Tools Lists (Including Depot Maintenance Repair Parts and Special Tools) for Battery Charger PP-6241/U.
TM 11-6625-2953-14	Operator's, Organizational, Direct Support, and General Support Maintenance Manual for Multimeter AN/USM-451.
TM 38-750	The Army Maintenance Management System (TAMMS).
TM 740-90-1	Administrative Storage of Equipment.
TM 750-244-2	Procedures for Destruction of Electronics Materiel to Prevent Enemy Use (Electronics Command).

APPENDIX B

MAINTENANCE ALLOCATION

Section I. INTRODUCTION

B-1. General

This appendix provides a summary of the maintenance operations for the PP-7549/U. It authorizes categories of maintenance for specific maintenance functions on repairable items and components and the tools and equipment required to perform each function. This appendix may be used as an aid in planning maintenance operations.

B-2. Maintenance Function

Maintenance functions will be limited to and defined as follows:

a. Inspect. To determine the serviceability of an item by comparing its physical, mechanical, and/or electrical characteristics with established standards through examination.

b. Test. To verify serviceability and to detect incipient failure by measuring the mechanical or electrical characteristics of an item and comparing those characteristics with prescribed standards.

c. Service. Operations required periodically to keep an item in proper operating condition, i.e., to clean (decontaminate), to preserve, to drain, to paint, or to replenish fuel, lubricants, hydraulic fluids, or compressed air supplies.

d. Adjust. To maintain, within prescribed limits, by bringing into proper or exact position, or by setting the operating characteristics to the specified parameters.

e. Align. To adjust specified variable elements of an item to bring about optimum or desired performance.

f. Calibrate. To determine and cause corrections to be made or to be adjusted on instruments or test measuring and diagnostic equipments used in precision measurement. Consists of comparisons of two instruments, one of which is a certified standard of known accuracy, to detect and adjust any discrepancy in the accuracy of the instrument being compared.

g. Install. The act of emplacing, seating, or fixing into position an item, part, module (component or assembly) in a manner to allow the proper functioning of the equipment or system.

h. Replace. The act of substituting a serviceable like type part, subassembly, or module (component or assembly) for an unserviceable counterpart.

i. Repair. The application of maintenance ser-

vices (inspect, test, service, adjust, align, calibrate, replace) or other maintenance actions (welding, grinding, riveting, straightening, facing, remachining, or resurfacing) to restore serviceability to an item by correcting specific damage, fault, malfunction, or failure in a part, subassembly, module (component or assembly), end item, or system.

j. Overhaul. That maintenance effort (service/action) necessary to restore an item to a completely serviceable/operational condition as prescribed by maintenance standards (i.e., DMWR) in appropriate technical publications. Overhaul is normally the highest degree of maintenance performed by the Army. Overhaul does not normally return an item to like new condition.

k. Rebuild. Consists of those services/actions necessary for the restoration of unserviceable equipment to a like new condition in accordance with original manufacturing standards. Rebuild is the highest degree of materiel maintenance applied to Army equipment. The rebuild operation includes the act of returning to zero those age measurements (hours, miles, etc.) considered in classifying Army equipments/components.

B-3. Column Entries

a. Column 1, Group Number. Column 1 lists group numbers, the purpose of which is to identify components, assemblies, subassemblies, and modules with the next higher assembly.

b. Column 2, Component/Assembly. Column 2 contains the noun names of components, assemblies, subassemblies, and modules for which maintenance is authorized.

c. Column 3, Maintenance Functions. Column 3 lists the functions to be performed on the item listed in column 2. When items are listed without maintenance functions, it is solely for purpose of having the group numbers in the MAC and RPSTL coincide.

d. Column 4, Maintenance Category. Column 4 specifies, by the listing of a "work time" figure in the appropriate subcolumn(s), the lowest level of maintenance authorized to perform the function listed in column 3. This figure represents the active time required to perform that maintenance function at the indicated category of maintenance. If the number or complexity of the tasks within the listed

maintenance function vary at different maintenance categories, appropriate "work time" figures will be shown for each category. The number of task-hours specified by the "work time" figure represents the average time required to restore an item (assembly, subassembly, component, module, end item or system) to a serviceable condition under typical field operating conditions. This time includes preparation time, troubleshooting time, and quality assurance/quality control time in addition to the time required to perform the specific tasks identified for the maintenance functions authorized in the maintenance allocation chart. Subcolumns of column 4 are as follows:

- C-Operator/Crew
- O-Organizational
- F-Direct Support
- H-General Support
- D-Depot

e. Column 5, Tools and Equipment. Column 5 specifies by code, those common tool sets (not individual tools) and special tools, test, and support equipment required to perform the designated function.

f. Column 6, Remarks. Column 6 contains an alphabetic code which leads to the remark in section IV, Remarks, which is pertinent to the item opposite the particular code.

B-4. Tools and Test Equipment Requirements (See III)

a. Tool or Test Equipment Reference Code. The numbers in this column coincide with the numbers used in the tools and equipment column of the MAC. The numbers indicate the applicable tool or test equipment for the maintenance functions.

b. Maintenance Category. The codes in this column indicate the maintenance category allocated the tool or test equipment.

c. Nomenclature. This column lists the noun name and nomenclature of the tools and test equipment required to perform the maintenance functions.

d. National/NATO Stock Number. This column lists the National/NATO stock number of the specific tool or test equipment.

e. Tool Number. This column lists the manufacturer's part number of the tool followed by the Federal Supply Code for manufacturers (5-digit) in parentheses.

B-5. Remarks (Sec IV)

a. Reference Code. This code refers to the appropriate item in section II, column 6.

b. Remarks. This column provides the required explanatory information necessary to clarify items appearing in section II.

(Next printed page is B-3)

SECTION II MAINTENANCE ALLOCATION CHART
FOR
POWER SUPPLY PP-7549/U

(1) GROUP NUMBER	(2) COMPONENT/ASSEMBLY	(3) MAINTENANCE FUNCTION	(4) MAINTENANCE CATEGORY					(5) TOOLS AND EQPT.	(6) REMARKS
			C	O	F	H	D		
00	POWER SUPPLY PP-7549/U	Inspect		0.1					
		Test				0.5			1 thru 3
		Calibrate				0.5			1 thru 3
		Repair		0.1		1.0			3
		Repair Overhaul					5.0		1 thru 3
01	STORAGE BATTERY BT-131	Inspect				0.1			3
		Test				0.1			2, 3
		Replace				0.2			3
		Repair				0.2			3
02	CIRCUIT CARD ASSY (A1)	Inspect				0.1			3
		Test				0.5			1 thru 3
		Replace				0.2			3
		Repair					0.5		3

SECTION III TOOL AND TEST EQUIPMENT REQUIREMENTS
FOR
POWER SUPPLY PP-7549/U

TOOL OR TEST EQUIPMENT REF CODE	MAINTENANCE CATEGORY	NOMENCLATURE	NATIONAL/NATO STOCK NUMBER	TOOL NUMBER
1	H, D	MULTIMETER ME-451/U	6625-01-060-6804	
2	H, D	BATTERY CHARGER PP-6241/U	6130-00-106-6445	
3	H, D	TOOL KIT, ELECTRONIC EQUIPMENT TK-100/G	5180-00-605-0079	

By Order of the Secretary of the Army:

Official:

ROBERT M. JOYCE
Brigadier General, United States Army
The Adjutant General

E. C. MEYER
General, United States Army
Chief of Staff

Distribution:

To be distributed in accordance with special mailing list.

RECOMMENDED CHANGES TO EQUIPMENT TECHNICAL PUBLICATIONS



THEN... JOT DOWN THE DOPE ABOUT IT ON THIS FORM. CAREFULLY TEAR IT OUT. FOLD IT AND DROP IT IN THE MAIL!

SOMETHING WRONG WITH THIS PUBLICATION?

FROM (PRINT YOUR UNIT'S COMPLETE ADDRESS)
 Commander
 Stateside Army Depot
 ATTN: AMSTA-US
 Stateside, N.J. 07703

DATE SENT
 10 July 1975

PUBLICATION NUMBER TM 11-5840-340-12	PUBLICATION DATE 23 Jan 74	PUBLICATION TITLE Radar Set AN/PRC-76
---	-------------------------------	--

BE EXACT PIN-POINT WHERE IT IS				IN THIS SPACE TELL WHAT IS WRONG AND WHAT SHOULD BE DONE ABOUT IT:
PAGE NO	PARA-GRAPH	FIGURE NO	TABLE NO	
2-25	2-28			<p>Recommend that the installation antenna alignment procedure be changed throughout to specify a 2° IFF antenna lag rather than 1°.</p> <p>REASON: Experience has shown that with only a 1° lag, the antenna servo system is too sensitive to wind gusting in excess of 25 knots, and has a tendency to rapidly accelerate and decelerate as it hunts, causing strain to the drive train. Hunting is minimized by adjusting the lag to 2° without degradation of operation.</p>
3-10	3-3		3-1	<p>Item 5, Function column. Change "2 db" to "3db."</p> <p>REASON: The adjustment procedure the the TRANS POWER FAULT indicator calls for a 3 db (500 watts) adjustment to light the TRANS POWER FAULT indicator.</p>
5-6	5-8			<p>Add new step f.1 to read, "Replace cover plate removed in step e.1, above."</p> <p>REASON: To replace the cover plate.</p>
		F03		<p>Zone C 3. On J1-2, change "+24 VDC to "+5 VDC."</p> <p>REASON: This is the output line of the 5 VDC power supply. +24 VDC is the input voltage.</p>

TEAR ALONG PERFORATED LINE

PRINTED NAME, GRADE OR TITLE, AND TELEPHONE NUMBER
 SSG I. M. DeSpirito 999-1776

SIGN HERE

RECOMMENDED CHANGES TO EQUIPMENT TECHNICAL PUBLICATIONS



THEN... JOT DOWN THE DOPE ABOUT IT ON THIS FORM. CAREFULLY TEAR IT OUT. FOLD IT AND DROP IT IN THE MAIL.

SOMETHING WRONG WITH THIS PUBLICATION?

FROM (PRINT YOUR UNIT'S COMPLETE ADDRESS)

DATE SENT

PUBLICATION NUMBER

TM 11-6625-2978-14

PUBLICATION DATE

18 Feb 82

PUBLICATION TITLE

Power Supply PP-7549/U

BE EXACT PIN-POINT WHERE IT IS

PAGE NO

PARA-GRAPH

FIGURE NO

TABLE NO

IN THIS SPACE TELL WHAT IS WRONG AND WHAT SHOULD BE DONE ABOUT IT:

PRINTED NAME GRADE OR TITLE AND TELEPHONE NUMBER

SIGN HERE

114R 4000-1 PREPARED IN

FILL IN YOUR
UNIT'S ADDRESS

FOLD BACK

DEPARTMENT OF THE ARMY

OFFICIAL BUSINESS
PENALTY FOR PRIVATE USE \$300

POSTAGE AND FEES PAID
DEPARTMENT OF THE ARMY
DOD 314



TEAR ALONG PERFORATED LINE

Commander
US Army Communications-
Electronics Command
ATTN: DRSEL-ME-MQ
Fort Monmouth, New Jersey 07703

THE METRIC SYSTEM AND EQUIVALENTS

WEIGHT MEASURE

1 Centimeter = 10 Millimeters = 0.01 Meters = 0.3937 Inches
 1 Meter = 100 Centimeters = 1000 Millimeters = 39.37 Inches
 1 Kilometer = 1000 Meters = 0.621 Miles

WEIGHTS

1 Gram = 0.001 Kilograms = 1000 Milligrams = 0.035 Ounces
 1 Kilogram = 1000 Grams = 2.2 lb.
 1 Metric Ton = 1000 Kilograms = 1 Megagram = 1.1 Short Tons

LIQUID MEASURE

1 Milliliter = 0.001 Liters = 0.0338 Fluid Ounces
 1 Liter = 1000 Milliliters = 33.82 Fluid Ounces

SQUARE MEASURE

1 Sq. Centimeter = 100 Sq. Millimeters = 0.155 Sq. Inches
 1 Sq. Meter = 10,000 Sq. Centimeters = 10.76 Sq. Feet
 1 Sq. Kilometer = 1,000,000 Sq. Meters = 0.386 Sq. Miles

CUBIC MEASURE

1 Cu. Centimeter = 1000 Cu. Millimeters = 0.06 Cu. Inches
 1 Cu. Meter = 1,000,000 Cu. Centimeters = 35.31 Cu. Feet

TEMPERATURE

$5/9(^{\circ}\text{F} - 32) = ^{\circ}\text{C}$
 212° Fahrenheit is equivalent to 100° Celsius
 90° Fahrenheit is equivalent to 32.2° Celsius
 32° Fahrenheit is equivalent to 0° Celsius
 $9/5^{\circ}\text{C} + 32 = ^{\circ}\text{F}$

APPROXIMATE CONVERSION FACTORS

TO CHANGE	TO	MULTIPLY BY
Inches	Centimeters	2.540
Feet	Meters	0.305
Yards	Meters	0.914
Miles	Kilometers	1.609
Square Inches	Square Centimeters	6.451
Square Feet	Square Meters	0.093
Square Yards	Square Meters	0.836
Square Miles	Square Kilometers	2.590
Acres	Square Hectometers	0.405
Cubic Feet	Cubic Meters	0.028
Cubic Yards	Cubic Meters	0.765
Fluid Ounces	Milliliters	29.573
its	Liters	0.473
arts	Liters	0.946
allons	Liters	3.785
Ounces	Grams	28.349
Pounds	Kilograms	0.454
Short Tons	Metric Tons	0.907
Pound-Feet	Newton-Meters	1.356
Pounds per Square Inch	Kilopascals	6.895
Miles per Gallon	Kilometers per Liter	0.425
Miles per Hour	Kilometers per Hour	1.609

TO CHANGE	TO	MULTIPLY BY
Centimeters	Inches	0.394
Meters	Feet	3.280
Meters	Yards	1.094
Kilometers	Miles	0.621
Square Centimeters	Square Inches	0.155
Square Meters	Square Feet	10.764
Square Meters	Square Yards	1.196
Square Kilometers	Square Miles	0.386
Square Hectometers	Acres	2.471
Cubic Meters	Cubic Feet	35.315
Cubic Meters	Cubic Yards	1.308
Milliliters	Fluid Ounces	0.034
Liters	Pints	2.113
Liters	Quarts	1.057
ers	Gallons	0.264
ms	Ounces	0.035
ograms	Pounds	2.205
Metric Tons	Short Tons	1.102
Newton-Meters	Pounds-Feet	0.738
Kilopascals	Pounds per Square Inch	0.145
ometers per Liter	Miles per Gallon	2.354
ometers per Hour	Miles per Hour	0.621

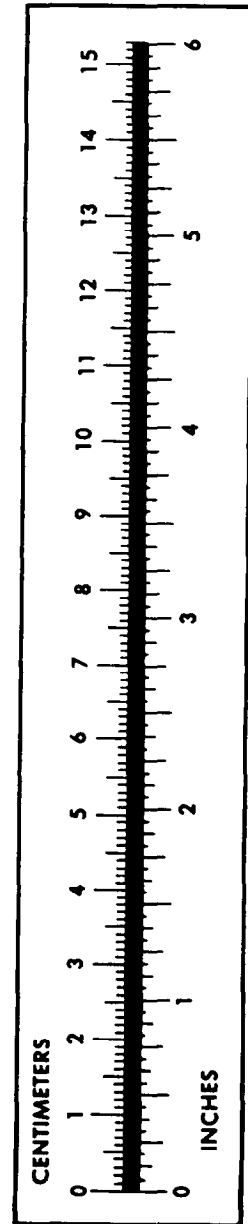

PIN: 050633-000