

# INSTRUCTION MANUAL

Serial Number B043362

**DIFFERENTIAL  
AMPLIFIER  
5A19N**



## WARRANTY

All TEKTRONIX instruments are warranted against defective materials and workmanship for one year. Any questions with respect to the warranty should be taken up with your TEKTRONIX Field Engineer or representative.

All requests for repairs and replacement parts should be directed to the TEKTRONIX Field Office or representative in your area. This will assure you the fastest possible service. Please include the instrument Type Number or Part Number and Serial Number with all requests for parts or service.

Specifications and price change privileges reserved.

Copyright © 1972 by Tektronix, Inc., Beaverton, Oregon.  
Printed in the United States of America. All rights reserved.  
Contents of this publication may not be reproduced in any form without permission of Tektronix, Inc.

U.S.A. and foreign TEKTRONIX products covered by U.S. and foreign patents and/or patents pending.

TEKTRONIX is a registered trademark of Tektronix, Inc.

# TABLE OF CONTENTS

		Page
<b>SECTION 1</b>	<b>OPERATING INSTRUCTIONS</b>	
	Controls and Connectors	1-1
	Basic Operation	1-1
	General Information	1-2
	Electrical Characteristics	1-4
	Repackaging for Shipment	1-5
<b>SECTION 2</b>	<b>THEORY OF OPERATION</b>	
	Block Diagram Description	2-1
	Circuit Operation	2-1
<b>SECTION 3</b>	<b>CALIBRATION</b>	
	Test Equipment Required	3-1
	Procedure	3-2
<b>SECTION 4</b>	<b>DIAGRAMS AND PARTS LISTS</b>	

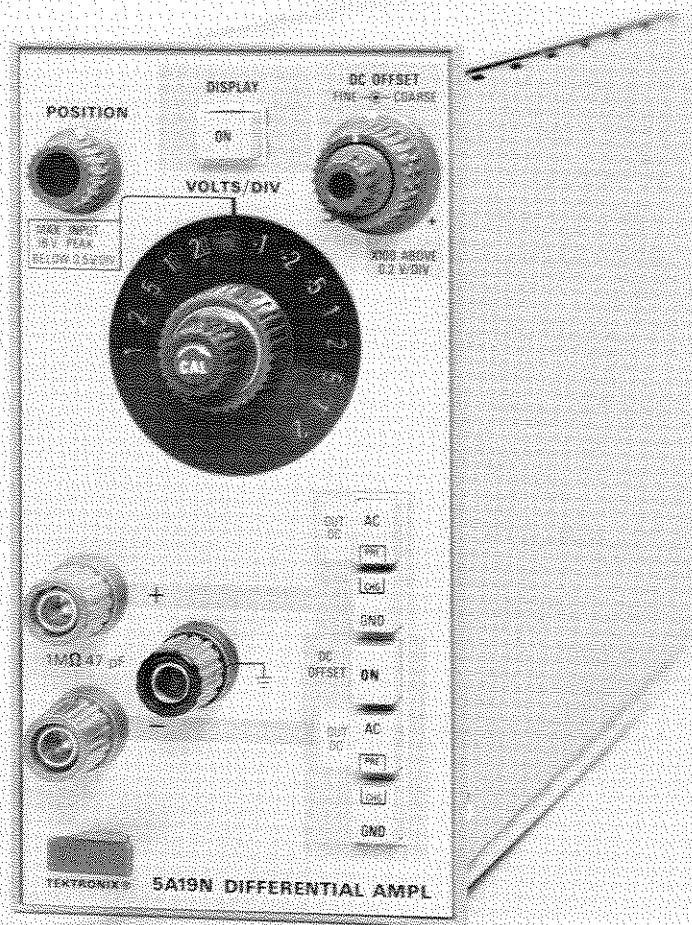

# SECTION 1

## OPERATING INSTRUCTIONS

### Instrument Description

The 5A19N Differential Amplifier is a differential amplifier plug-in unit for use with TEKTRONIX 5100-Series Oscilloscopes. The unit features high sensitivity with direct-coupled inputs, moderate common-mode rejection, and variable DC offset. An illuminated knob skirt provides deflection factor readout. The unit has a maximum bandwidth capability of DC to 2 megahertz.

### CONTROLS AND CONNECTORS

This is a brief description of the function or operation of the front-panel controls and connectors. More detailed information is given under General Information.

DISPLAY	Applies and removes logic levels to the oscilloscope system to enable or disable plug-in operation. Switch is functional only when plug-in is operated in one of the vertical plug-in compartments.
POSITION	Positions display.
VOLTS/DIV	Volts per major graticule division. Selects calibrated deflection factor in a 1-2-5 sequence, from 1 mV/Div to 20 V/Div in 14 steps. Knob skirt is illuminated to indicate deflection factor.
Variable (Volts/Div)	Provides uncalibrated, continuously variable deflection factor between calibrated steps; extends range to 50 V/Div.
DC OFFSET	COARSE and FINE controls provide on-screen display of small signal variations on relatively large DC levels. DC OFFSET push-button must be pressed to the ON position. Internal shunts select offset ranges (see General Information).

### Input Coupling Pushbuttons

AC-DC: Button pushed in selects capacitive coupling of signal applied to associated input connector; button out selects direct coupling of input signal.

GND: Disconnects the input signal and provides ground reference to the amplifier input stage.

PRE CHG: Both AC-DC and GND buttons pushed in permits pre-charging of the coupling capacitor to the input signal DC level. Release GND button for measurement.

DC OFFSET: Disconnects — amplifier input from the front panel and reconnects it to an internal offset voltage source.

### + and — Input Connectors

5-way binding post connectors for application of external voltage signals. Connector labeled + indicates that a positive-going signal will cause upward deflection; connector labeled — indicates that a positive-going signal will cause downward deflection.

### BASIC OPERATION

#### Preparation

The 5A19N is calibrated and ready for use as it is received. It can be installed in any compartment of the 5100N-Series Power Supply/Amplifier module, but it is intended for primary use in vertical compartments (the center and left compartments). For X-Y operation, the 5A19N may also be installed in the horizontal (right) compartment (refer to the Oscilloscope System Instruction manual for information on X-Y operation).

#### NOTE

*The Power Supply/Amplifier module is designed so that in the absence of DISPLAY logic levels from the vertical plug-ins, it will display the output of the unit in the left compartment.*

## Operating Instructions—5A19N

To install, align the upper and lower rails of the 5A19N with the plug-in compartment tracks and fully insert it (the plug-in panel must be flush with the oscilloscope panel). To remove, pull the release latch to disengage the 5A19N from the oscilloscope.

The first few steps of the following procedure are intended to help place the trace on the screen quickly and prepare the instrument for immediate use. The remainder of the steps demonstrate some of the basic functions of the 5A19N. Operation of other instruments in the system is described in the instruction manuals for those units.

1. Insert the unit all the way into the oscilloscope system plug-in compartment.

2. Turn the oscilloscope Intensity control fully counterclockwise and turn the oscilloscope system Power On. Preset the time-base and triggering controls for a 2-millisecond/division sweep rate and automatic triggering.

3. Set the 5A19N front-panel controls as follows:

### DISPLAY

DISPLAY	ON (readout illuminates)
POSITION	Midrange
VOLTS/DIV	.1 V
+ Input Coupling	DC, GND
– Input Coupling	DC, GND

### NOTE

*About five minutes is sufficient time for warmup when using the 5A19N.*

4. Adjust the Intensity control for normal viewing of the trace. The trace should appear near the graticule center.

5. Move the trace two divisions below the graticule centerline with the POSITION control.

6. Apply a 400-millivolt peak-to-peak signal (available at the oscilloscope Calibrator loop) through a test lead or 1X probe to the + input connector.

### NOTE

*Use a BNC female to dual banana adapter, TEKTRONIX Part No. 103-0090-00, to connect a probe to the 5A19N input.*

7. For DC-coupled, single-ended operation, release the + input GND button. The display should be a four division square wave with the bottom of the display at the reference established in step 5. Rotate the Variable Volts/Div control counterclockwise out of its detent position, observing reduction of the display. Return the Variable control to the detent (CAL) position.

8. For AC-coupled, single-ended operation, re-position the display with the POSITION control to place the bottom of the display at the graticule centerline.

9. Push in the AC button and note that the display shifts downward about two divisions to its average level.

10. For AC-coupled differential operation, short across the + and – input connectors and set the – input to AC (AC button in, GND button out). The calibrator signal is now coupled to both inputs as a common-mode signal. A straight line display should be observed, since the common-mode signal is being rejected.

## Step Attenuator Balance Check

The DC balance is adjusted internally by R75 (BAL). If this control is not properly adjusted, the CRT zero reference point (trace or spot) will shift vertically due to differential DC imbalance in the amplifier as the VOLTS/DIV switch is rotated throughout its range. The shift is more noticeable on the most sensitive positions.

a. With the instrument operating, ground both the + and – inputs (GND buttons pushed in), set the VOLTS/DIV switch to 20 V, and move the trace to graticule center with the POSITION control. Check for 0.5 div or less trace shift as the VOLTS/DIV switch is rotated throughout its range.

b. If the trace shift is excessive, refer to the Step Attenuator Balance adjustment in the Calibration Procedure.

## Gain Check

Whenever the 5A19N is inserted into a plug-in compartment other than the one in which it was calibrated, the amplifier gain should be checked and, if necessary, adjusted. See the Calibration Procedure in this manual for complete instructions.

## GENERAL INFORMATION

### Applying Signals

When measuring DC voltages, use the largest deflection factor (20 V/Div) when first connecting the 5A19N to an

unknown voltage source. If the deflection is too small to make the measurement, switch to a lower deflection factor.

**DC Offset.** Internal shunts (see Fig. 3-1) are provided to select from two offset ranges:  $\pm 15$  volts or  $\pm 350$  volts. By shunting across position (1),  $\pm 15$  volts of offset is available from 1 mV/div to 0.2 V/div or an equivalent  $\pm 350$  volts from 0.5 V/div to 20 V/div. Shunting across position (2) provides  $\pm 15$  volts at any deflection factor setting.

When using DC offset at the lowest deflection factor positions, it may be difficult to position the display on screen due to the resolution of the DC OFFSET control. If so, use the BEAM FINDER button on the Display Module to locate and position the display.

**Pre-charging.** When only the AC component of a signal having both AC and DC components is to be measured, or whenever a signal having a different DC level is connected, use the Input Coupling switches (AC and GND push-buttons) to take advantage of the pre-charging circuit incorporated in the unit. The pre-charging circuit permits charging the coupling capacitor to the DC source voltage when the AC and GND buttons are pressed in. The procedure for using this circuit is as follows:

- a. Before connecting the 5A19N to a signal containing a DC component, push in the AC and GND buttons. Then connect the input to the circuit under test.
- b. Wait about one second for the coupling capacitor to charge.
- c. Remove the ground from the coupling capacitor (GND button out). The display will remain on-screen, and the AC component can be measured in the usual manner.

### Signal Input Connectors

When connecting signals to the + and – input connectors on the 5A19N, consider the method of coupling that will be used. Sometimes unshielded test leads can be used to connect the 5A19N to a signal source, particularly when a high level, low-frequency signal is monitored at a low impedance point. However, when any of these factors is missing, it becomes increasingly important to use shielded signal cables. In all cases, the signal-transporting leads should be kept as short as practical.

When making single-ended input measurements (conventional amplifier operation), be sure to establish a common ground connection between the device under test and the 5A19N. The shield of a coaxial cable is normally used for this purpose.

In some cases, differential measurements require no common ground connection,<sup>1</sup> and therefore are less susceptible to interference by ground-loop currents. Some problems with stray magnetic coupling into the signal-transporting leads can also be minimized by using a differential rather than a single-ended measurement. These considerations are discussed later in this section under Differential Operation.

It is always important to consider the signal source loading (and resulting change in the source operating characteristics) due to the signal-transporting leads and the input circuit of the 5A19N. The circuit at the input connectors can normally be represented by a 1 megohm resistance to ground paralleled by 47 pF. A few feet of shielded cable (20 to 40 pF per foot) may increase the parallel capacitance to 100 pF or more. In many cases, the effects of these resistive and capacitive loads may be too great and it may be desirable to minimize them through the use of an attenuator probe.

Attenuator probes not only decrease the resistive-capacitive loading of a signal source, but also extend the measurement range of the 5A19N to include substantially higher voltages. Passive attenuator probes having attenuation factors of 10X, 100X, and 1000X, as well as other special-purpose types, are available through your TEKTRONIX Field Engineer or Field Office.

### Display Polarity

Single-ended signals applied to the + input connector produce a display in phase with the input signal. Signals applied to the – input connector will be inverted.

A similar polarity relationship exists for differentially applied signals, but it pertains to the direction of voltage change at one input with respect to the other, rather than with respect to chassis potential.

### Deflection Factor

The amount of trace deflection produced by a signal is determined by the signal amplitude, the attenuation factor (if any) of the probe, the setting of the VOLTS/DIV switch, and the setting of the Variable control. The calibrated deflection factors are indicated by the VOLTS/DIV switch only when the Variable control is rotated fully clockwise into the detent position.

<sup>1</sup>The DC plus AC voltages on the test points (with respect to the chassis potential of the 5A19N) should be limited to the levels listed in Electrical Characteristics under Common-Mode Rejection. Higher levels will degrade the common-mode rejection ratio and exceed the input voltage rating of the unit.

The range of the Variable control is at least 2.5:1. It provides uncalibrated deflection factors covering the full range between the fixed settings of the VOLTS/DIV switch. The control can be set to extend the deflection factor to at least 50 volts/division.

### Voltage Comparison Measurements

Some applications require deflection factors other than the fixed values provided by the VOLTS/DIV switch. One such application is comparison of signal amplitudes by ratio rather than by absolute voltage. To accomplish this, apply a reference signal to either input of the 5A19N, and set the VOLTS/DIV switch and Variable control so that the reference display covers the desired number of graticule divisions. Do not change this setting of the Variable control throughout the subsequent comparisons. The settings of the VOLTS/DIV switch can be changed, however, to accommodate large ratios. In doing so, regard the numbers which designate the switch positions as ratio factors rather than voltages.

### Differential Operation

Single-ended measurements often yield unsatisfactory results because of interference resulting from ground-loop currents between the 5A19N and the device under test. In other cases, it may be desirable to eliminate a DC voltage by means other than the use of a DC-blocking capacitor, which could limit the low-frequency response.

These limitations of single-ended measurements are effectively eliminated using differential measurements. Differential measurements are made by connecting each input (+ input and - input) to selected points in the test circuit. Since the chassis of the 5A19N need not be connected in any way to the test circuit, there are few limitations to the selection of these test points. In any case, do not exceed the maximum safe input voltages listed in Electrical Characteristics.

Both Input Coupling switches should be set to the same position, AC or DC, depending on the method of signal coupling required.

Only the voltage difference between two signals is amplified and displayed in differential measurements, while the common-mode signals (common in amplitude, frequency, and phase) are rejected. See Fig. 1-1.

The ability of the 5A19N to reject common-mode signals is indicated by the common-mode rejection ratio (CMRR). CMRR is at least 1000:1 at the input connectors for the lower deflection factors (1 mV/DIV and 200 mV/DIV) when signals between DC and 10 kHz are DC coupled to the inputs. To illustrate this characteristic, assume that a single-ended input signal consists of an unwanted 60 Hz signal at 1 volt peak to peak, plus a desired signal at 10 mV peak to peak. If an attempt is made to display the described signal (single-ended measurements) at 2 mV/DIV, the 60 Hz signal will produce a deflection equivalent to 500 divisions and the 10 mV signal will be lost.

If the same 10 mV signal is measured differentially with the 60 Hz signal common to both inputs, no more than one part in 1000 of the common-mode signal will appear in the display. The desired signal will produce a display of 5 divisions, with not more than 0.5 division of display produced by the common-mode signal (CMRR not specified when residual display is 0.1 division or less).

There are a number of factors which can degrade common-mode rejection. The principal requirement for maximum rejection is for the common-mode signal to arrive at the input FET gates in precisely the same form. A difference of only 0.25% in the attenuation factors of the input attenuators may reduce the rejection ratio to 400:1. Likewise, any difference in source impedance at the two points in the source under test will degrade the rejection ratio. Attenuator probes which do not have adjustable R and C will reduce the rejection ratio. The actual rejection ratio depends upon the attenuation accuracy of the probe (swapping probes may improve the rejection ratio).

Outside influences such as magnetic fields can also degrade the performance, particularly when low level signals are involved. Magnetic interference may be minimized by using identical signal-transporting leads to the two inputs and twisting the two leads together over as much of their length as possible.

## ELECTRICAL CHARACTERISTICS

In this manual the word Volts/Div or division refers to major graticule division.

### Performance Conditions

The following characteristics apply only if the 5A19N is operating within the environmental limits described in the 5100-series oscilloscope system manual. In addition, the 5A19N must have been calibrated at an ambient temperature between +20°C and +30°C.

**BANDWIDTH (-3 dB):** DC (direct) coupled, DC to at least 2 MHz. AC (capacitive) coupled, 2 Hz to at least 2 MHz.

**DEFLECTION FACTOR:** 1 mV/div to 20 V/div within 2% in a 14 step 1-2-5 sequence. Uncalibrated, continuously variable between steps and to 50 V/div.

**COMMON-MODE REJECTION:** DC (direct) coupled, at least 60 dB from 1 mV/div to 0.2 V/div with up to 32 V P-P sine wave. At least 40 dB from 0.5 V/div to 20 V/div with up to 350 V P-P sine wave.

**DC OFFSET:** At least  $\pm 15$  V from 1 mV/div to 0.2 V/div or  $\pm 350$  V from 0.5 V/div to 20 V/div with an internal shunt at position (1). At least  $\pm 15$  V at any deflection factor setting with the internal shunt at position (2).

**INPUT RC:** 1 M $\Omega$  within 0.3% paralleled by  $\approx 47$  pF.

**MAXIMUM INPUT VOLTAGE:** 350 V (DC + peak AC).

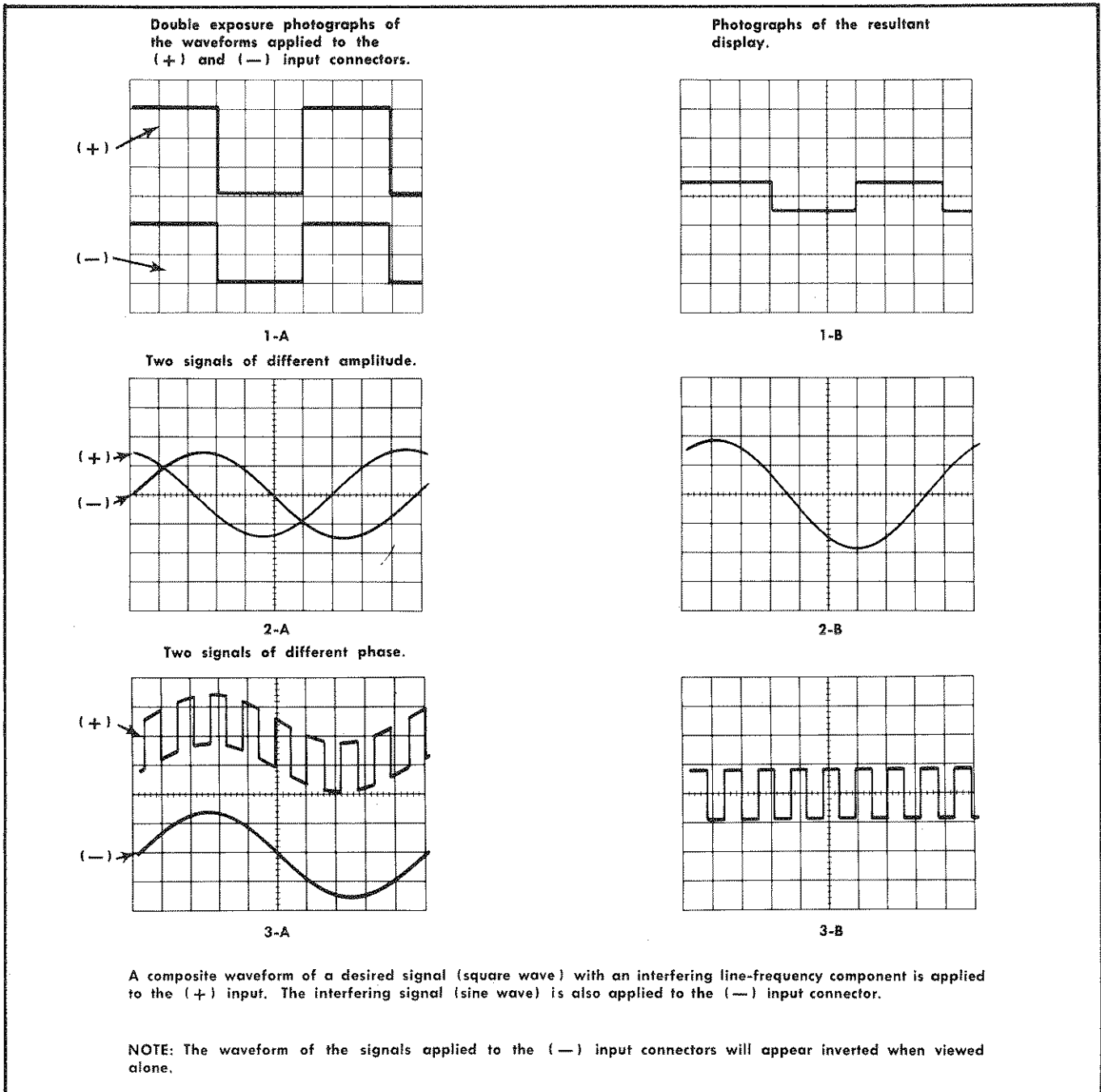

Fig. 1-1. Three examples of differential applications.

### REPACKAGING FOR SHIPMENT

If the Tektronix instrument is to be shipped to a Tektronix Service Center for service or repair, attach a tag showing: owner (with address) and the name of an individual at your firm that can be contacted, complete instrument serial number and a description of the service required.

Save and re-use the package in which your instrument was shipped. If the original packaging is unfit for use or not available, repackage the instrument as follows:

Surround the instrument with polyethylene sheeting to protect the finish of the instrument. Obtain a carton of corrugated cardboard of the correct carton strength and having inside dimensions of no less than six inches more than the instrument dimensions. Cushion the instrument by tightly packing three inches of dunnage or urethane foam between carton and instrument, on all sides. Seal carton with shipping tape or industrial stapler.

The carton test strength for your instrument is 200 pounds.

# SECTION 2

## THEORY OF OPERATION

### Introduction

This section of the manual contains an electrical description of the circuits in the 5A19N Differential Amplifier unit. Complete schematic diagrams and an overall block diagram of the unit are given on pullout pages at the back of this manual.

### BLOCK DIAGRAM DESCRIPTION

When the DISPLAY button is pressed, a logic level is applied to the oscilloscope to enable 5A19N operation (switch function is limited to operation in a vertical compartment), and the front-panel readout lamp illuminates to indicate the ON mode.

Voltage signals applied to the + and – input connectors can be passed directly to the attenuators (DC coupled) or they can be capacitively (AC) coupled to block the DC component of the signal. The GND switch disconnects DC-coupled signals and applies a reference ground to the preamplifier input; for AC-coupled signals, the coupling capacitor is allowed to pre-charge to the DC level of the signal, preventing a damaging current surge when the ground is removed.

The input attenuators are frequency-compensated voltage dividers. 1X attenuation is provided for positions 1 m to 0.2 of the VOLTS/DIV switch, and 100X attenuation is provided for positions 0.5 to 20.

The gain switching stage consists of two identical operational amplifiers operating in a differential mode. The VOLTS/DIV switch changes the value of the common source/emitter resistor between the two sides, thus changing the gain for the various deflection factors.

The offset generator compensates for DC levels of  $\pm 15$  volts or  $\pm 350$  volts depending upon the deflection factor and the internal shunt. The offset voltage is applied to the – input of the gain switching amplifier to offset the DC level at the + input.

The output differential amplifier is operated push-pull, presenting a signal to the output terminals of the same polarity as that applied to the preamplifier input. Preamplifier output shunting produced by the Variable Volts/

Div control provides a means of varying the gain of the 5A19N. Internal Gain control R110 provides emitter degeneration. A positioning-current driver is connected to the output lines to alter the quiescent CRT beam position.

A triggering signal is tapped from the preamplifier output stage, amplified and made available to an associated time-base plug-in unit. Triggering signal amplitude is about 0.25 volt per displayed division.

### CIRCUIT OPERATION

#### Plug-In Logic

When the DISPLAY button, S130, is pressed, a logic level is applied to the electronic switching circuit in the oscilloscope to enable plug-in operation. Power is applied to illuminate the front-panel knob-skirt readout lamp, indicating the ON mode.

#### Input Coupling

Signals applied to the front-panel + and – input connectors may be capacitive coupled (AC), direct coupled (DC), or internally disconnected (GND). Input coupling is selected by means of two pushbutton switches at each input, S10A and S10B for the + input and S40A and S40B for the – input.

Assuming that a signal is applied to the + input, the applied signal is passed directly to the attenuators when both buttons are out. When the AC button is pressed, C10 is placed in the circuit to couple signals to about two hertz ( $-3$  dB point) and higher to the attenuator. This capacitor blocks any DC component of the signal. When the GND button is pressed, a ground reference is provided to the input of the amplifier without the need to remove the applied signal from the input connector.

#### NOTE

*When DC levels (above 20 volts) are to be blocked by AC coupling, both the AC and GND buttons should be pressed in (PRE CHG) while input connections are made or broken, or when voltage levels are changed. This will allow the coupling capacitor to charge without drawing excessive current from the signal source.*

## Input Attenuators

The input attenuators are frequency-compensated voltage dividers which provide 100X attenuation in positions 0.5 to 20 of the VOLTS/DIV switch. At DC and for low-frequency signals, the dividers are essentially resistive (attenuation ratio determined by the resistance ratio). At higher frequencies, the capacitive reactance becomes effective and the attenuation ratio is determined by the impedance ratio.

In addition to providing constant 100X attenuation at all frequencies within the bandwidth capabilities of the instrument, the input attenuators maintain a constant input RC characteristic (one megohm paralleled by about 47 pF) for settings 0.5 to 20 of the VOLTS/DIV switch.

## Input Protection

Negative voltage excursions are clamped at  $-20$  volts by diodes CR24 or CR26. The  $-20$  volt clamping reference is generated by VR25 and C25.

Positive voltage excursions are clamped at  $+20$  volts by the gate-to-drain circuit of Q70A/B and diodes CR90 or CR96. The  $+20$  volt clamping reference is generated by VR95 and C95.

## DC Offset

The Offset Generator is composed of divider network R60A/R60B/R64/R68. Coarse and fine offset adjustment is provided by R60A/B. When the DC OFFSET pushbutton is pressed  $\pm 15$  volts is available from the Offset Generator either directly to the inverting input of the Gain Switching Amplifier or through the Attenuator depending upon whether a shunt is connected across position (1) or (2). A shunt across position (1) provides an offset range of  $\pm 15$  volts from 1 mV/div to 0.2 V/div and the equivalent of  $\pm 350$  volts from 0.5 V/div to 20 V/div; position (2) provides  $\pm 15$  volts at any deflection factor setting.

## Common-Mode Rejection

When identical signals are present at the gates of Q70A/B the sources follow the gate signal; thus, no difference voltage appears across gain-setting resistors R80 through R85. The emitter connection of Q90 and Q96 to a

reference supply provides a constant voltage across drain load resistors R70 and R74. Therefore, the current through R70 and R74 is also constant and passes through Q70A/B.

Since there is no voltage difference across resistors R80 through R85, the same current is applied to the emitters of Q94 and Q98. A constant current through Q94 and Q98 causes an equal voltage across load resistors R94 and R98 which results in a fixed output from the preamplifier.

## Gain Switching Stage

The Gain Switching Stage consists of two identical feedback amplifiers connected in a differential configuration. Gain is determined by the ratio of the common collector to the emitter/source resistances. R75 (BAL) develops a voltage due to the source current through Q70B and adjusts out any unbalance between the two feedback amplifiers.

## Output Amplifier

The output amplifier consists of push-pull amplifier Q100/Q110. With a signal applied, potentiometer R110 (GAIN) provides emitter degeneration, the gain being determined by the total emitter resistance. This allows the overall gain of the 5A19N to be adjusted to match the main-frame requirements. Also, the Variable VOLTS/DIV control, R105, allows gain to be adjustable over a 2.5 to 1 ratio by shunting the collector loads of the preceding stages.

Divider R119/R121 and POSITION control R120 either add to or subtract from the Q100/Q110 currents to alter the quiescent vertical position of the display.

## Trigger Signal Amplifier

Differential amplifier Q140/Q144 receives the triggering signal from the collectors of Q94/Q98. The triggering signal is amplified and passed through emitter-follower Q148, where it is made available to an associated time-base unit via output terminal A4. The triggering signal is of the same polarity as that applied to the gate of Q70, and has an amplitude of about 0.25 volt per displayed division.

# SECTION 3

## CALIBRATION

### Introduction

This section of the manual contains a procedure to return the circuits of the 5A19N within their designed operating capabilities. Calibration is generally required after a repair has been made, or after long time intervals in which normal aging of components may affect instrument accuracy. For initial inspection, verify instrument operation by performing the procedures described under General Information in Section 1.

### Instrument Maintenance

If necessary, clean and inspect this instrument as outlined in the Maintenance section of the Oscilloscope System manual. Also, the System manual contains information for general maintenance of this instrument, including preventive maintenance, component identification and replacement, etc.

### Service Available

Tektronix, Inc. provides complete instrument repair and calibration at local Field Service Centers and at the Factory Service Center. Contact your local Tektronix Field Office or representative for further information.

## TEST EQUIPMENT REQUIRED

### General

The following test equipment and accessories, or the equivalent is required for complete calibration of the 5A19N. Specifications given for the test equipment are the minimum necessary for accurate calibration. Therefore, some of the specifications listed may be less rigorous than the actual performance capabilities of the test equipment. All test equipment is assumed to be correctly calibrated and operating within the listed specifications.

### Calibration Equipment Alternatives

If other test equipment is substituted, control settings or setup may need altering to meet the requirements of the equipment used. Detailed operating instructions for the test equipment are not given in this procedure. Refer to the instruction manual for the test equipment if more information is needed.

### Special Calibration Fixtures

Special Tektronix calibration fixtures are used in this procedure only where they facilitate instrument calibration. These special fixtures are available from Tektronix, Inc. Order by part number through your local Tektronix Field Office or representative.

### Test Instruments

1. 5100-series oscilloscope system. For this procedure, a 5110 Oscilloscope with a 5B10N Time-Base plug-in is used.
2. Constant amplitude sine-wave generator. Frequency, 2 Hz to 2 MHz; output amplitude, about 0.5 V to at least 32 V P-P. For example, General Radio 1310-B and 1210-C Oscillator (use GR Type 274 QBJ Adapter to provide BNC output).
3. Standard amplitude calibrator. Output signal, 1 kHz square wave; output amplitude, 5 mV to at least 100 V; accuracy, within 0.25%. TEKTRONIX PG 506 Calibration Generator recommended (requires a TM 500-series power module).

### Accessories

1. BNC female to dual banana adapter provides connection to binding posts. Tektronix Part No. 103-0090-00.
2. Coaxial cable. Impedance, 50  $\Omega$ ; length 42 inches; connectors, BNC. Tektronix Part No. 012-0057-01.
3. Input RC normalizer. RC time constant, 47  $\mu$ s (1 M $\Omega$  X 47 pF); connectors, BNC. Tektronix Calibration Fixture 067-0541-00 recommended.
4. In-line termination. Impedance, 50  $\Omega$ ; accuracy within 2%; connectors, BNC. Tektronix Part No. 011-0049-01 recommended.
5. Plug-in extension for the 5100-series oscilloscope system. Tektronix Calibration Fixture 067-0645-03 (not mandatory for this procedure).

PROCEDURE

Initial Control Settings

Preparation

1. Remove the protective cover from the left side of the 5A19N and also the left side-panel from the 5100-series oscilloscope. (The plug-in extender can be used to gain access to the internal adjustments, instead of removing the oscilloscope side-panel.) Insert the 5A19N into the center plug-in compartment, and the 5B10N into the right compartment.

2. Connect the oscilloscope to the power source for which it is wired. Set the controls as described under Initial Control Settings. Refer to Fig. 3-1 for location of internal adjustments and test points.

3. Allow 5 minutes for warmup before calibration.

NOTE

*This instrument should be calibrated at an ambient temperature between +20°C and +30°C (+68°F and +86°F) for best accuracy.*

NOTE

*Do not preset internal controls unless they are known to be significantly out of adjustment, or unless repairs have been made in the circuit. In these instances, the internal controls can be set to midrange.*

5A19N

DISPLAY	ON
POSITION	Midrange
VOLTS/DIV	50 m
Variable (CAL)	Fully cw (detent)
+ and - Input Coupling	GND

Time Base (5B10N)

Position	Sweep starts at left edge of graticule
Seconds/Div.	1 m
Triggering Mode	Auto Trig. + Slope.
	AC Couple
Triggering Source	Composite
Triggering Level	Midrange
All other pushbuttons	Out

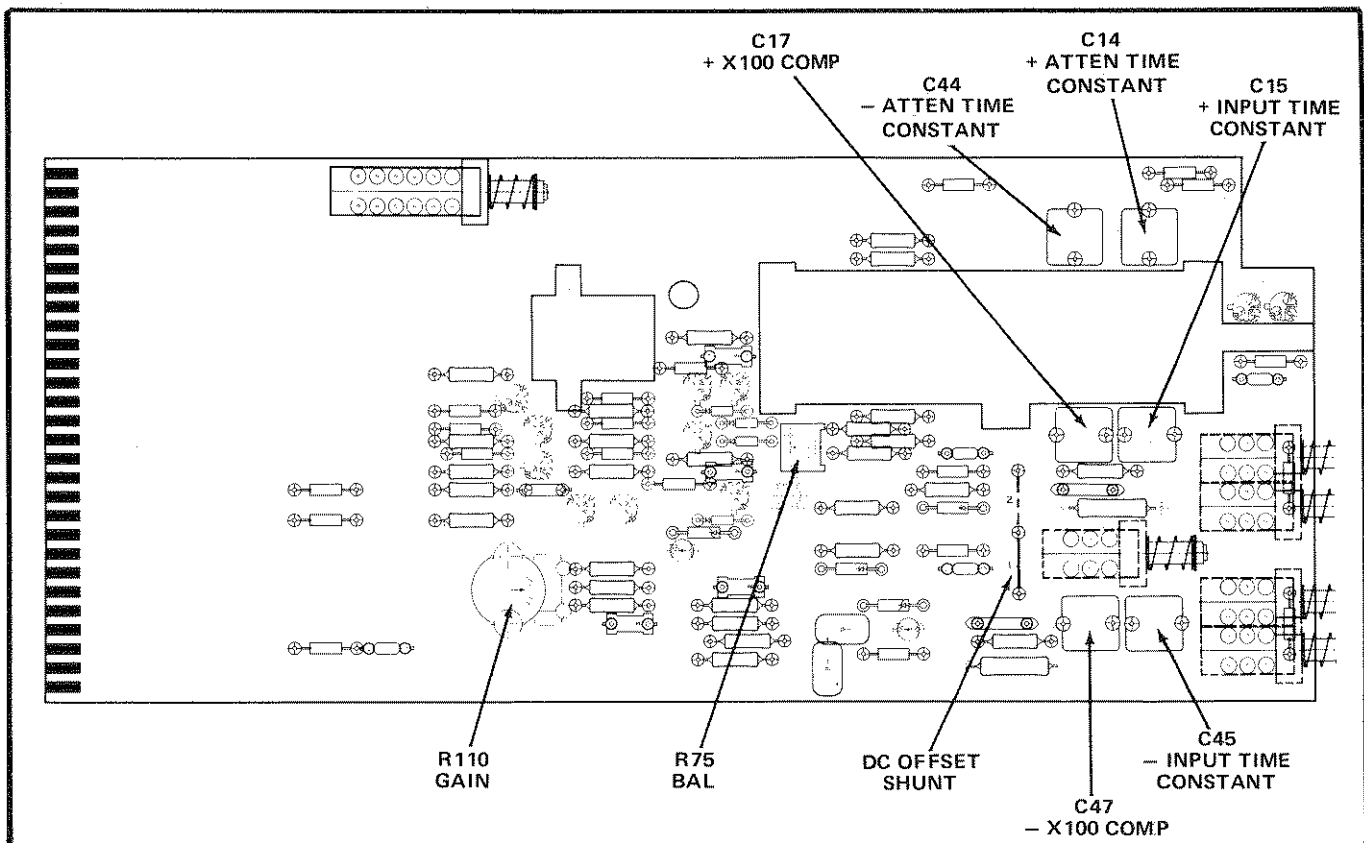

Fig. 3-1. Internal adjustment locations.

### 1. Step Attenuator Balance

a. Adjust R75 (BAL) for minimum trace shift while switching the VOLTS/DIV from 1 m to 2 m and back.

### 2. Input Compensation

a. Press to release the + GND button and set the VOLT/DIV to 100 m. Apply a 0.5 V square wave from the Standard Amplitude Calibrator through the Input RC Normalizer to the + input. Adjust Time Base Level for a stable display.

b. Adjust C15 (INPUT TIME CONSTANT) for the best square front corner on the display.

c. Apply a 2 V square wave from the Standard Amplitude Calibrator and set the VOLTS/DIV to 0.5. Adjust C17 (X 100 COMP) and C14 (ATTEN TIME CONSTANT) for the best square front corner on the display.

d. Repeat the preceding procedure for the - input. Adjust C45 (INPUT TIME CONSTANT) then C47 (X 100 COMP) and C44 (ATTEN TIME CONSTANT) for the best square front corner on the display.

### 3. Amplifier Gain

a. Set the VOLTS/DIV to 10 m and apply a 50 mV square wave from the Standard Amplitude Calibrator to the + input.

b. Adjust R110 (GAIN) for exactly 5 divisions of display amplitude.

c. Turn Variable VOLTS/DIV (CAL) fully ccw and check that the display amplitude is less than 2 divisions. Return CAL to detent (fully cw).

### 4. VOLTS/DIV Accuracy

a. Set the VOLTS/DIV to 20 and apply a 100 V square wave from the Standard Amplitude Calibrator to the + input.

b. Switch the VOLTS/DIV down through each position while also switching the Standard Amplitude Calibrator to maintain either 4 or 5 divisions of display amplitude. Check that the display amplitude is within 2% of the VOLTS/DIV setting.

### 5. Common-Mode Rejection Ratio

a. Release - GND button and set the VOLTS/DIV to 10 m. Apply a 32 V P-P, 10 kHz signal from the Constant Amplitude Sine-Wave Generator through the BNC female to Dual Banana Adapter to the + and - inputs. Check that display amplitude is 3.2 divisions or less.

### 6. Bandwidth

a. Press the - GND button. Set the VOLTS/DIV to 10 m, and Time Base Seconds/Div to 1 m.

b. Apply a 1 kHz, 6 division signal from the Constant Amplitude Sine-Wave Generator to the + input. Set the Generator for a 2 MHz output. Check for at least a 4.2 division display amplitude.

This completes the 5A19N calibration procedure.



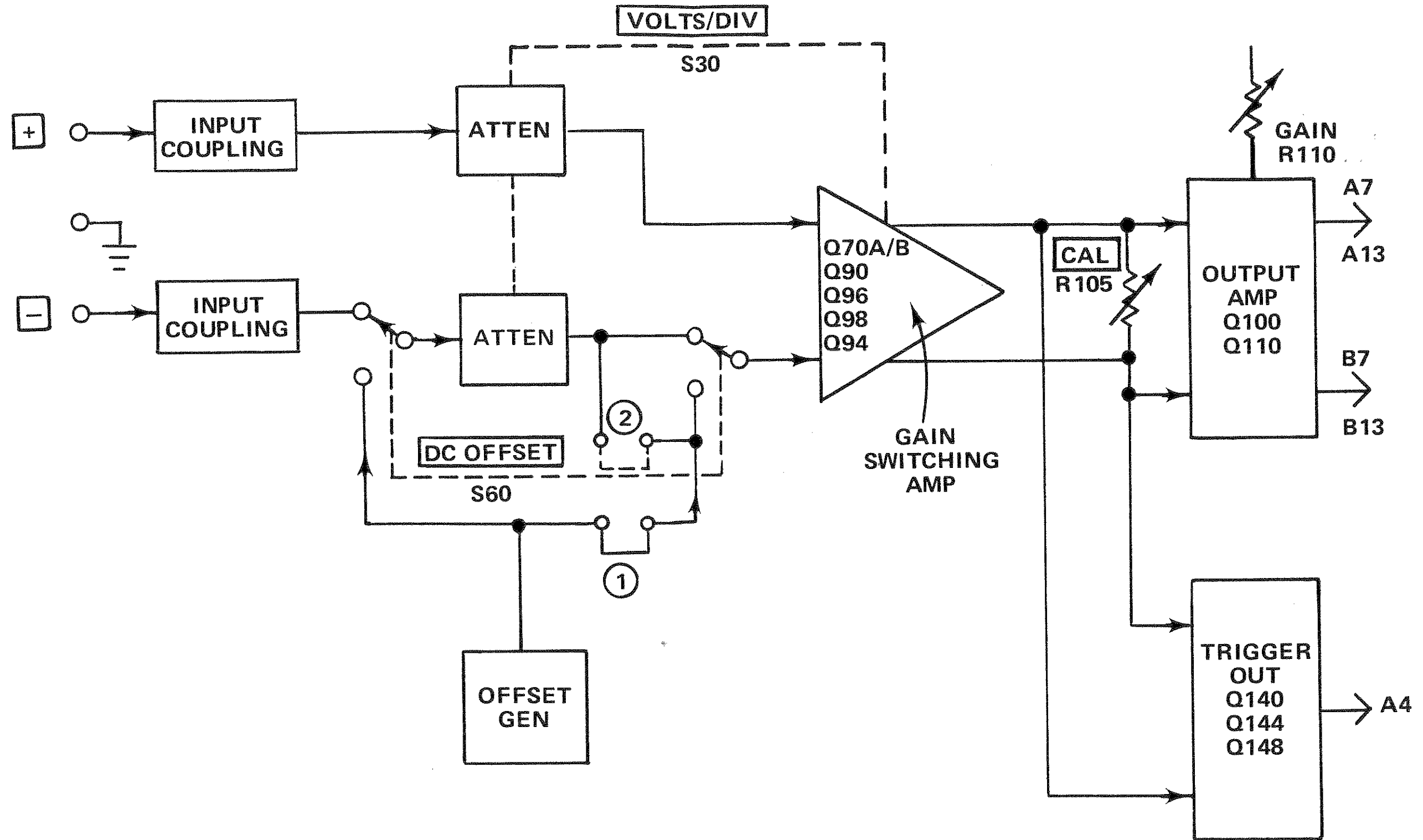

5A19N COMPONENT LOCATIONS

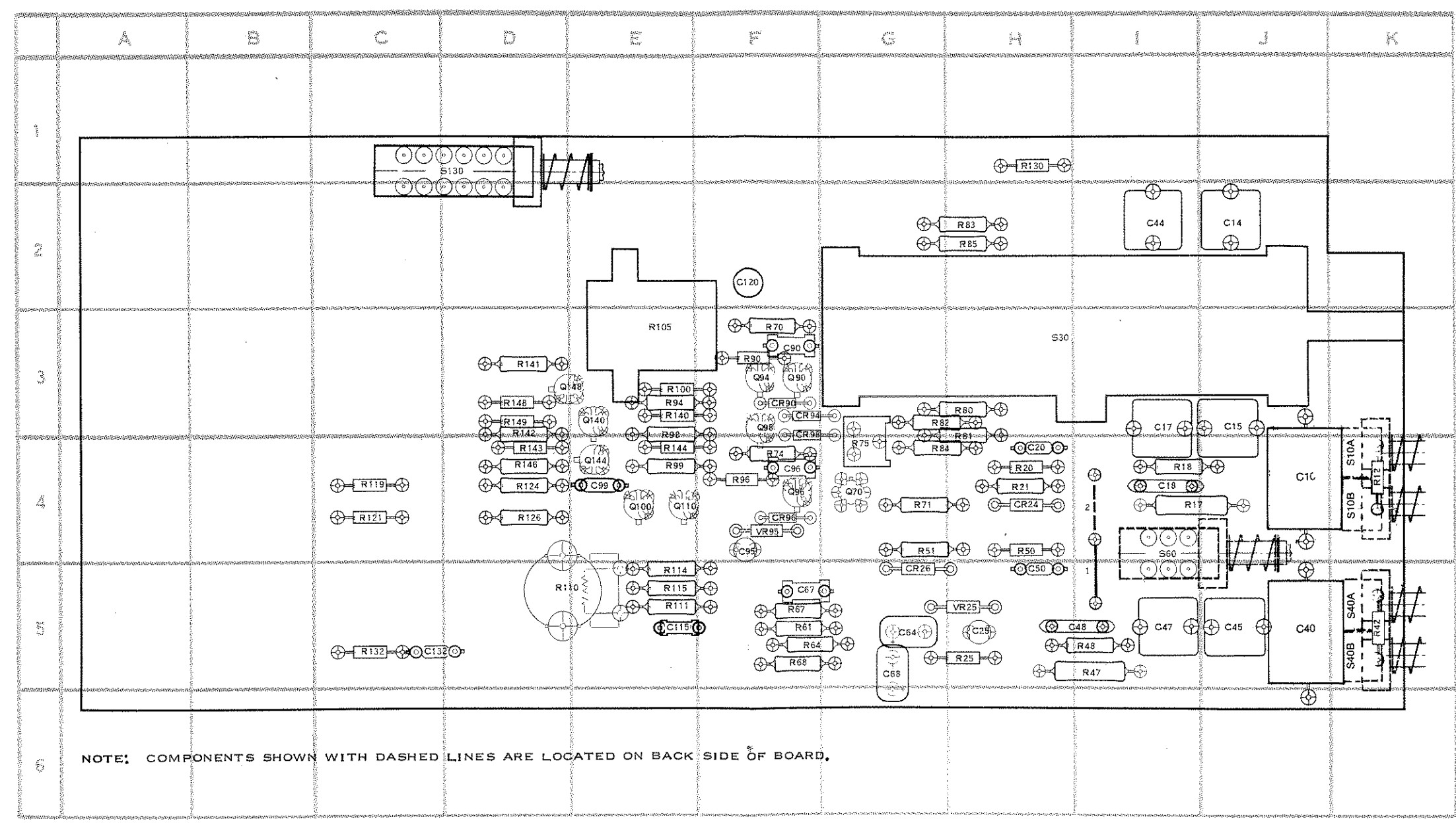

NOTE: COMPONENTS SHOWN WITH DASHED LINES ARE LOCATED ON BACK SIDE OF BOARD.

CKT NO	GRID LOC
C10	K4
C14	J2
C15	J4
C17	I4
C18	I4
C20	H4
C25	H5
C40	K5
C44	I2
C45	J5
C47	I5
C48	I5
C50	H5
C64	G5
C67	G5
C68	G6
C90	F3
C95	F5
C96	F4
C99	E4
C115	F5
C120	F3
C132*	D5
CR24	H4
CR26	G5
CR90	F4
CR94	G4
CR96	F4
CR98	G4
Q70A,B	G4
Q90	G3
Q94	F3
Q96	G4
Q98	F4
Q100	E4
Q110	F4
Q140	E4
Q144	E4
Q148	E3

CKT NO	GRID LOC
R12	K4
R17	J4
R18	J4
R20	H4
R21	H4
R25	H6
R42	K5
R47	I6
R48	I5
R50	H5
R51	H5
R61	G5
R64	G5
R67	G5
R68	G6
R70	F3
R71	H4
R74	F4
R75	G4
R80	H4
R81	H4
R82	H4
R83	H2
R84	H4
R85	H2
R90	F3
R94	F4
R96	F4
R98	F4
R99	F4
R100	F3
R105	E3
R110	E5
R111	F5
R114	F5
R115	F5
R119	C4
R121	C4
R124	D4
R126	D4
R130*	H2
R132*	C5

CKT NO	GRID LOC
R140	F4
R141	D3
R142	D4
R143	D4
R144	F4
R146	D4
R148	D4
R149	D4
S10A	K4
S10B	
S30	I3
S40A	K5
S40B	
S60	I5
S130	D2
VR25	H5
VR95	F5

\*See Parts List for serial number ranges.



# REPLACEABLE ELECTRICAL PARTS

## PARTS ORDERING INFORMATION

Replacement parts are available from or through your local Tektronix, Inc. Field Office or representative.

Changes to Tektronix instruments are sometimes made to accommodate improved components as they become available, and to give you the benefit of the latest circuit improvements developed in our engineering department. It is therefore important, when ordering parts, to include the following information in your order: Part number, instrument type or number, serial number, and modification number if applicable.

If a part you have ordered has been replaced with a new or improved part, your local Tektronix, Inc. Field Office or representative will contact you concerning any change in part number.

Change information, if any, is located at the rear of this manual.

## SPECIAL NOTES AND SYMBOLS

X000 Part first added at this serial number  
00X Part removed after this serial number

## ITEM NAME

In the Parts List, an Item Name is separated from the description by a colon (:). Because of space limitations, an Item Name may sometimes appear as incomplete. For further Item Name identification, the U.S. Federal Cataloging Handbook H6-1 can be utilized where possible.

## ABBREVIATIONS

ACTR	ACTUATOR	PLSTC	PLASTIC
ASSY	ASSEMBLY	QTZ	QUARTZ
CAP	CAPACITOR	RECP	RECEPTACLE
CER	CERAMIC	RES	RESISTOR
CKT	CIRCUIT	RF	RADIO FREQUENCY
COMP	COMPOSITION	SEL	SELECTED
CONN	CONNECTOR	SEMICOND	SEMICONDUCTOR
ELCTLT	ELECTROLYTIC	SENS	SENSITIVE
ELEC	ELECTRICAL	VAR	VARIABLE
INCAND	INCANDESCENT	WW	WIREWOUND
LED	LIGHT EMITTING DIODE	XFMR	TRANSFORMER
NONWIR	NON WIREWOUND	XTAL	CRYSTAL

CROSS INDEX—MFR. CODE NUMBER TO MANUFACTURER

Mfr. Code	Manufacturer	Address	City, State, Zip
00853	SANGAMO ELECTRIC CO., S. CAROLINA DIV.	P O BOX 128	PICKENS, SC 29671
01121	ALLEN-BRADLEY COMPANY	1201 2ND STREET SOUTH	MILWAUKEE, WI 53204
04713	MOTOROLA, INC., SEMICONDUCTOR PROD. DIV.	5005 E MCDOWELL RD, PO BOX 20923	PHOENIX, AZ 85036
07263	FAIRCHILD SEMICONDUCTOR, A DIV. OF FAIRCHILD CAMERA AND INSTRUMENT CORP.	464 ELLIS STREET 12515 CHADRON AVE.	MOUNTAIN VIEW, CA 94042 HAWTHORNE, CA 90250
07910	TELEDYNE SEMICONDUCTOR		
08806	GENERAL ELECTRIC CO., MINIATURE LAMP PRODUCTS DEPARTMENT	NELA PARK	CLEVELAND, OH 44112
12697	CLAROSTAT MFG. CO., INC.	LOWER WASHINGTON STREET	DOVER, NH 03820
32997	BOURNS, INC., TRIMPOT PRODUCTS DIV.	1200 COLUMBIA AVE.	RIVERSIDE, CA 92507
53944	ELT INC., GLOW LITE DIVISION	BOX 698	PAULS VALLEY, OK 73075
56289	SPRAGUE ELECTRIC CO.		NORTH ADAMS, MA 01247
58474	SUPERIOR ELECTRIC CO., THE	383 MIDDLE ST.	BRISTOL, CT 06010
71450	CTS CORP.	1142 W. BEARDSLEY AVE.	ELKHART, IN 46514
72982	ERIE TECHNOLOGICAL PRODUCTS, INC.	644 W. 12TH ST.	ERIE, PA 16512
74970	JOHNSON, E. F., CO.	299 10TH AVE. S. W.	WASECA, MN 56093
80009	TEKTRONIX, INC.	P O BOX 500	BEAVERTON, OR 97077
90201	MALLORY CAPACITOR CO., DIV. OF P. R. MALLORY AND CO., INC.	3029 E WASHINGTON STREET P O BOX 372	INDIANAPOLIS, IN 46206
91637	DALE ELECTRONICS, INC.	P. O. BOX 609	COLUMBUS, NE 68601

Ckt No.	Tektronix Part No.	Serial/Model No. Eff	Dscont	Name & Description	Mfr Code	Mfr Part Number
A1	670-1948-00	B010100	B029999	CKT BOARD ASSY:MAIN	80009	670-1948-00
A1	670-1948-01	B030000		CKT BOARD ASSY:MAIN	80009	670-1948-01
C10	285-0724-02			CAP.,FXD,PLSTC:0.1UF,+5%-15%,600V	80009	285-0724-02
C14	281-0081-00			CAP.,VAR,AIR DI:1.8-13PF,375VDC	74970	189-6-5
C15	281-0131-00			CAP.,VAR,AIR DI:2.4-24.5PF,250V	74970	189-509-5
C17	281-0081-00			CAP.,VAR,AIR DI:1.8-13PF,375VDC	74970	189-6-5
C18	283-0594-00			CAP.,FXD,MICA D:0.001UF,1%,100V	00853	D151F102F0
C20	283-0002-00			CAP.,FXD,CER DI:0.01UF,+80-20%,500V	72982	811-546E103Z
C25	290-0534-00			CAP.,FXD,ELCTLT:1UF,20%,35V	56289	196D105X0035HA1
C40	285-0724-02			CAP.,FXD,PLSTC:0.1UF,+5%-15%,600V	80009	285-0724-02
C44	281-0081-00			CAP.,VAR,AIR DI:1.8-13PF,375VDC	74970	189-6-5
C45	281-0081-00			CAP.,VAR,AIR DI:1.8-13PF,375VDC	74970	189-6-5
C47	281-0081-00			CAP.,VAR,AIR DI:1.8-13PF,375VDC	74970	189-6-5
C48	283-0594-00			CAP.,FXD,MICA D:0.001UF,1%,100V	00853	D151F102F0
C50	283-0002-00			CAP.,FXD,CER DI:0.01UF,+80-20%,500V	72982	811-546E103Z
C64	290-0527-00			CAP.,FXD,ELCTLT:15UF,20%,20V	90201	TDC156M020FL
C67	281-0536-00			CAP.,FXD,CER DI:1000PF,10%,500V	72982	301055X5P102K
C68	290-0527-00			CAP.,FXD,ELCTLT:15UF,20%,20V	90201	TDC156M020FL
C90	281-0534-00			CAP.,FXD,CER DI:3.3PF,+/-0.25PF,500V	72982	301-000C0J0339C
C95	290-0512-00			CAP.,FXD,ELCTLT:22UF,20%,15V	56289	196D226X0015KA1
C96	281-0534-00			CAP.,FXD,CER DI:3.3PF,+/-0.25PF,500V	72982	301-000C0J0339C
C99	283-0000-00			CAP.,FXD,CER DI:0.001UF,+100-0%,500V	72982	831-516E102P
C115	281-0544-00			CAP.,FXD,CER DI:5.6PF,10%,500V	72982	301-000C0H0569D
C120	290-0534-00			CAP.,FXD,ELCTLT:1UF,20%,35V	56289	196D105X0035HA1
C132	283-0002-00	B010100	B029999X	CAP.,FXD,CER DI:0.01UF,+80-20%,500V	72982	811-546E103Z
CR24	152-0246-00			SEMICONV DEVICE:SILICON,400PIV,200MA	80009	152-0246-00
CR26	152-0246-00			SEMICONV DEVICE:SILICON,400PIV,200MA	80009	152-0246-00
CR90	152-0141-02			SEMICONV DEVICE:SILICON,30V,150MA	07910	1N4152
CR94	152-0141-02			SEMICONV DEVICE:SILICON,30V,150MA	07910	1N4152
CR96	152-0141-02			SEMICONV DEVICE:SILICON,30V,150MA	07910	1N4152
CR98	152-0141-02			SEMICONV DEVICE:SILICON,30V,150MA	07910	1N4152
DS130	150-0111-00	B010100	B029999	LAMP,GLOW:NEON,1.2MA	53944	A1B-3
DS130	150-0130-00	B030000		LAMP,INCAND:5V,60MA	08806	2200DX
J10	129-0064-01			POST,BDG,ELEC:RED,5-WAY MINIATURE	58474	BB10167G2BX
J30	129-0064-00			POST,BDG,ELEC:CHARCOAL,5-WAY MINIATURE	58474	BINP BB10167G13T
J40	129-0064-01			POST,BDG,ELEC:RED,5-WAY MINIATURE	58474	BB10167G2BX
Q70A,B	151-1049-00			TRANSISTOR:SILICON,JFE,N-CHANNEL,DUAL	80009	151-1049-00
Q90	151-0342-00			TRANSISTOR:SILICON,PNP	80009	151-0342-00
Q94	151-0342-00			TRANSISTOR:SILICON,PNP	80009	151-0342-00
Q96	151-0342-00			TRANSISTOR:SILICON,PNP	80009	151-0342-00
Q98	151-0342-00			TRANSISTOR:SILICON,PNP	80009	151-0342-00
Q100	151-0341-00			TRANSISTOR:SILICON,NPN	07263	S040065
Q110	151-0341-00			TRANSISTOR:SILICON,NPN	07263	S040065
Q140	151-0341-00			TRANSISTOR:SILICON,NPN	07263	S040065
Q144	151-0341-00			TRANSISTOR:SILICON,NPN	07263	S040065
Q148	151-0341-00			TRANSISTOR:SILICON,NPN	07263	S040065
R10	321-0177-00			RES.,FXD,FILM:681 OHM,1%,0.125W	91637	MFF1816G681ROF
R12	316-0105-00			RES.,FXD,CMPSN:1M OHM,10%,0.25W	01121	CB1051
R17	322-0624-03			RES.,FXD,FILM:990K OHM,0.25%,0.25W	91637	MFF1421D99002C
R18	321-0289-03			RES.,FXD,FILM:10K OHM,0.25%,0.125W	91637	MFF1816D10001C
R20	315-0474-00			RES.,FXD,CMPSN:470K OHM,5%,0.25W	01121	CB4745

Replaceable Electrical Parts—5A19N

Ckt No.	Tektronix Part No.	Serial/Model No. Eff	Dscont	Name & Description	Mfr Code	Mfr Part Number
R21	321-0181-00			RES.,FXD,FILM:750 OHM,1%,0.125W	91637	MFF1816G750R0F
R25	315-0512-00			RES.,FXD,CMPSN:5.1K OHM,5%,0.25W	01121	CB5125
R40	321-0177-00			RES.,FXD,FILM:681 OHM,1%,0.125W	91637	MFF1816G681R0F
R42	316-0105-00			RES.,FXD,CMPSN:1M OHM,10%,0.25W	01121	CB1051
R47	322-0624-03			RES.,FXD,FILM:990K OHM,0.25%,0.25W	91637	MFF1421D99002C
R48	321-0289-03			RES.,FXD,FILM:10K OHM,0.25%,0.125W	91637	MFF1816D10001C
R50	315-0474-00			RES.,FXD,CMPSN:470K OHM,5%,0.25W	01121	CB4745
R51	321-0181-00			RES.,FXD,FILM:750 OHM,1%,0.125W	91637	MFF1816G750R0F
R60A,B	311-0679-00			RES.,VAR,NONWIR:PNL,2 X 10K OHM,0.5W	12697	CM39682
R61	321-0283-00			RES.,FXD,FILM:8.66K OHM,1%,0.125W	91637	MFF1816G86600F
R64	321-0225-00			RES.,FXD,FILM:2.15K OHM,1%,0.125W	91637	MFF1816G21500F
R67	321-0437-00			RES.,FXD,FILM:348K OHM,1%,0.125W	91637	MFF1816G34802F
R68	321-0225-00			RES.,FXD,FILM:2.15K OHM,1%,0.125W	91637	MFF1816G21500F
R70	321-0292-00			RES.,FXD,FILM:10.7K OHM,1%,0.125W	91637	MFF1816G10701F
R71	321-0068-00			RES.,FXD,FILM:49.9 OHM,1%,0.125W	91637	MFF1816G49R90F
R74	321-0292-00			RES.,FXD,FILM:10.7K OHM,1%,0.125W	91637	MFF1816G10701F
R75	311-1222-00			RES.,VAR,NONWIR:100 OHM,20%,0.50W	32997	3386F-T04-101
R80	321-0771-03			RES.,FXD,FILM:50 OHM,0.25%,0.125W	91637	MFF1816D50R00C
R81	321-0097-03			RES.,FXD,FILM:100 OHM,0.25%,0.125W	91637	MFF1816D100R0C
R82	321-0612-03			RES.,FXD,FILM:500 OHM,0.25%,0.125W	91637	MFF1816D500R0C
R83	321-0612-03			RES.,FXD,FILM:500 OHM,0.25%,0.125W	91637	MFF1816D500R0C
R84	321-0816-03			RES.,FXD,FILM:5K OHM,0.25%,0.125W	91637	MFF1816D50000C
R85	321-0816-03			RES.,FXD,FILM:5K OHM,0.25%,0.125W	91637	MFF1816D50000C
R90	315-0333-00			RES.,FXD,CMPSN:33K OHM,5%,0.25W	01121	CB3335
R94	321-0203-00			RES.,FXD,FILM:1.27K OHM,1%,0.125W	91637	MFF1816G12700F
R96	315-0333-00			RES.,FXD,CMPSN:33K OHM,5%,0.25W	01121	CB3335
R98	321-0203-00			RES.,FXD,FILM:1.27K OHM,1%,0.125W	91637	MFF1816G12700F
R99	321-0263-00			RES.,FXD,FILM:5.36K OHM,1%,0.125W	91637	MFF1816G53600F
R100	315-0821-00			RES.,FXD,CMPSN:820 OHM,5%,0.25W	01121	CB8215
R105	311-1394-00			RES.,VAR,WW:20K OHM,10%,0.50W	01121	10M3394
R110	311-1124-00			RES.,VAR,NONWIR:250 OHM,30%,0.25W	71450	201-YA5533
R111	321-0214-00			RES.,FXD,FILM:1.65K OHM,1%,0.125W	91637	MFF1816G16500F
R114	321-0290-00			RES.,FXD,FILM:10.2K OHM,1%,0.125W	91637	MFF1816G10201F
R115	321-0290-00			RES.,FXD,FILM:10.2K OHM,1%,0.125W	91637	MFF1816G10201F
R119	315-0223-00			RES.,FXD,CMPSN:22K OHM,5%,0.25W	01121	CB2235
R120	311-0546-00	B010100	B019999	RES.,VAR,NONWIR:10K OHM,20%,0.75W	80009	311-0546-00
R120	311-1460-00	B020000		RES.,VAR NONWIR:10K OHM,20%,1W	01121	73J1G040L130M
R121	315-0223-00			RES.,FXD,CMPSN:22K OHM,5%,0.25W	01121	CB2235
R124	321-0193-00			RES.,FXD,FILM:1K OHM,1%,0.125W	91637	MFF1816G10000F
R126	321-0193-00			RES.,FXD,FILM:1K OHM,1%,0.125W	91637	MFF1816G10000F
R130	315-0124-00	B010100	B029999	RES.,FXD,CMPSN:120K OHM,5%,0.25W	01121	CB1245
R130	315-0270-00	B030000		RES.,FXD,CMPSN:27 OHM,5%,0.25W	01121	CB2705
R132	315-0103-00	B010100	B029999X	RES.,FXD,CMPSN:10K OHM,5%,0.25W	01121	CB1035
R140	315-0471-00			RES.,FXD,CMPSN:470 OHM,5%,0.25W	01121	CB4715
R141	321-0254-00			RES.,FXD,FILM:4.32K OHM,1%,0.125W	91637	MFF1816G43200F
R142	321-0294-00			RES.,FXD,FILM:11.3K OHM,1%,0.125W	91637	MFF1816G11301F
R143	315-0751-00			RES.,FXD,CMPSN:750 OHM,5%,0.25W	01121	CB7515
R144	315-0471-00			RES.,FXD,CMPSN:470 OHM,5%,0.25W	01121	CB4715
R146	321-0294-00			RES.,FXD,FILM:11.3K OHM,1%,0.125W	91637	MFF1816G11301F
R148	315-0181-00			RES.,FXD,CMPSN:180 OHM,5%,0.25W	01121	CB1815
R149	316-0153-00			RES.,FXD,CMPSN:15K OHM,10%,0.25W	01121	CB1531

Ckt No.	Tektronix Part No.	Serial/Model No. Eff	Dscont	Name & Description	Mfr Code	Mfr Part Number
S10A) S10B)	260-1207-00			SWITCH,PUSH:2 MODULE	80009	260-1207-00
S30	105-0318-00			DRUM ASSY,CAM S:VOLTS/DIV	80009	105-0318-00
S40A) S40B)	260-1207-00			SWITCH,PUSH:2 MODULE	80009	260-1207-00
S60	260-1445-00			SWITCH,PUSH:PP,1 STA,NON-SHORT	80009	260-1445-00
S130	260-1209-00			SWITCH,PUSH:4PDT	80009	260-1209-00
VR25	152-0304-00			SEMICOND DEVICE:ZENER,0.4W,20V,5%	04713	1N968B
VR95	152-0149-00			SEMICOND DEVICE:ZENER,0.4W,10V,5%	04713	1N961B



**PARTS LIST**

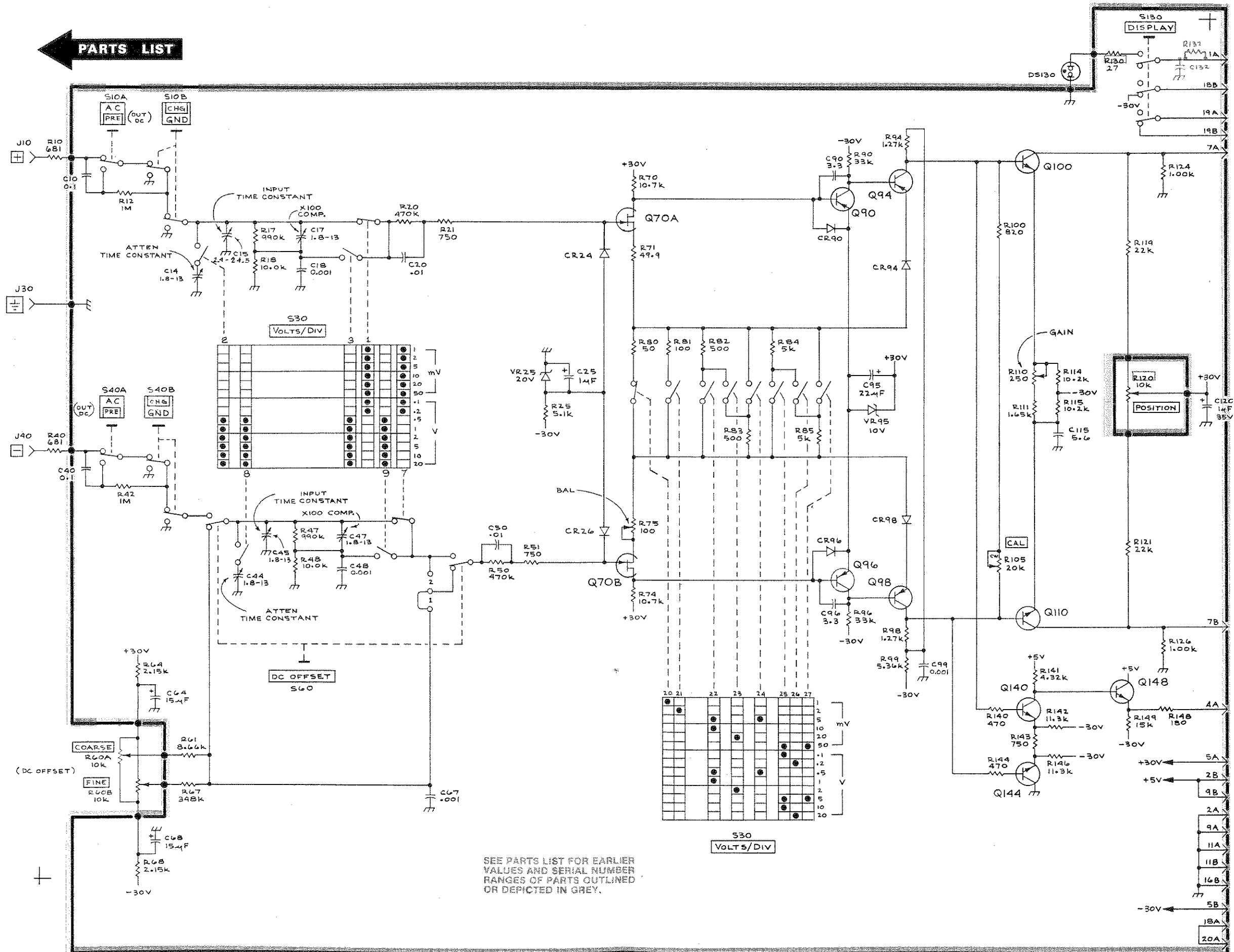

SEE PARTS LIST FOR EARLIER VALUES AND SERIAL NUMBER RANGES OF PARTS OUTLINED OR DEPICTED IN GREY.



# REPLACEABLE MECHANICAL PARTS

## PARTS ORDERING INFORMATION

Replacement parts are available from or through your local Tektronix, Inc. Field Office or representative.

Changes to Tektronix instruments are sometimes made to accommodate improved components as they become available, and to give you the benefit of the latest circuit improvements developed in our engineering department. It is therefore important, when ordering parts, to include the following information in your order: Part number, instrument type or number, serial number, and modification number if applicable.

If a part you have ordered has been replaced with a new or improved part, your local Tektronix, Inc. Field Office or representative will contact you concerning any change in part number.

Change information, if any, is located at the rear of this manual.

## SPECIAL NOTES AND SYMBOLS

X000 Part first added at this serial number

00X Part removed after this serial number

## FIGURE AND INDEX NUMBERS

Items in this section are referenced by figure and index numbers to the illustrations.

## INDENTATION SYSTEM

This mechanical parts list is indented to indicate item relationships. Following is an example of the indentation system used in the description column.

```

1 2 3 4 5           Name & Description
Assembly and/or Component
Attaching parts for Assembly and/or Component
    --- * ---
Detail Part of Assembly and/or Component
Attaching parts for Detail Part
    --- * ---
Parts of Detail Part
Attaching parts for Parts of Detail Part
    --- * ---

```

Attaching Parts always appear in the same indentation as the item it mounts, while the detail parts are indented to the right. Indented items are part of, and included with, the next higher indentation. The separation symbol --- \* --- indicates the end of attaching parts.

**Attaching parts must be purchased separately, unless otherwise specified.**

## ITEM NAME

In the Parts List, an Item Name is separated from the description by a colon (:). Because of space limitations, an Item Name may sometimes appear as incomplete. For further Item Name identification, the U.S. Federal Cataloging Handbook H6-1 can be utilized where possible.

## ABBREVIATIONS

"	INCH	ELCTRN	ELECTRON	IN	INCH	SE	SINGLE END
#	NUMBER SIZE	ELEC	ELECTRICAL	INCAND	INCANDESCENT	SECT	SECTION
ACTR	ACTUATOR	ELECTLT	ELECTROLYTIC	INSUL	INSULATOR	SEMICON	SEMICONDUCTOR
ADPTR	ADAPTER	ELEM	ELEMENT	INTL	INTERNAL	SHLD	SHIELD
ALIGN	ALIGNMENT	EPL	ELECTRICAL PARTS LIST	LPHLDR	LAMPHOLDER	SHLDR	SHOULDERED
AL	ALUMINUM	EQPT	EQUIPMENT	MACH	MACHINE	SKT	SOCKET
ASSEM	ASSEMBLED	EXT	EXTERNAL	MECH	MECHANICAL	SL	SLIDE
ASSY	ASSEMBLY	FIL	FILLISTER HEAD	MTG	MOUNTING	SLFLKG	SELF-LOCKING
ATTEN	ATTENUATOR	FLEX	FLEXIBLE	NIP	NIPPLE	SLVG	SLEEVEING
AWG	AMERICAN WIRE GAGE	FLH	FLAT HEAD	NON WIRE	NOT WIRE WOUND	SPR	SPRING
BD	BOARD	FLTR	FILTER	OBD	ORDER BY DESCRIPTION	SQ	SQUARE
BRKT	BRACKET	FR	FRAME or FRONT	OD	OUTSIDE DIAMETER	SST	STAINLESS STEEL
BRS	BRASS	FSTNR	FASTENER	OYH	OVAL HEAD	STL	STEEL
BRZ	BRONZE	FT	FOOT	PH BRZ	PHOSPHOR BRONZE	SW	SWITCH
BSHG	BUSHING	FXD	FIXED	PL	PLAIN or PLATE	T	TUBE
CAB	CABINET	GSKT	GASKET	PLSTC	PLASTIC	TERM	TERMINAL
CAP	CAPACITOR	HDL	HANDLE	PN	PART NUMBER	THD	THREAD
CER	CERAMIC	HEX	HEXAGON	PNH	PAN HEAD	THK	THICK
CHAS	CHASSIS	HEX HD	HEXAGONAL HEAD	PWR	POWER	TNSN	TENSION
CKT	CIRCUIT	HEX SOC	HEXAGONAL SOCKET	RCPT	RECEPTACLE	TPG	TAPPING
COMP	COMPOSITION	HLCPS	HELICAL COMPRESSION	RES	RESISTOR	TRH	TRUSS HEAD
CONN	CONNECTOR	HLEXT	HELICAL EXTENSION	RGD	RIGID	V	VOLTAGE
COV	COVER	HV	HIGH VOLTAGE	RLF	RELIEF	VAR	VARIABLE
CPLG	COUPLING	IC	INTEGRATED CIRCUIT	RTNR	RETAINER	W/	WITH
CRT	CATHODE RAY TUBE	ID	INSIDE DIAMETER	SCH	SOCKET HEAD	WSHR	WASHER
DEG	DEGREE	IDNT	IDENTIFICATION	SCOPE	OSCILLOSCOPE	XFMR	TRANSFORMER
DWR	DRAWER	IMPLR	IMPELLER	SCR	SCREW	XSTR	TRANSISTOR

CROSS INDEX—MFR. CODE NUMBER TO MANUFACTURER

Mfr. Code	Manufacturer	Address	City, State, Zip
08261	SPECTRA-STRIP CORP.	7100 LAMPSON AVE.	GARDEN GROVE, CA 92642
45722	USM CORP., PARKER-KALON FASTENER DIV.		CAMPBELLSVILLE, KY 42718
58474	SUPERIOR ELECTRIC CO., THE	383 MIDDLE ST.	BRISTOL, CT 06010
71159	BRISTOL SOCKET SCREW, DIV. OF AMERICAN CHAIN AND CABLE CO., INC.	P O BOX 2244, 40 BRISTOL ST.	WATERBURY, CT 06720
71785	TRW, CINCH CONNECTORS	1501 MORSE AVENUE	ELK GROVE VILLAGE, IL 60007
73743	FISCHER SPECIAL MFG. CO.	446 MORGAN ST.	CINCINNATI, OH 45206
74445	HOLO-KROME CO.	31 BROOK ST. WEST	HARTFORD, CT 06110
78189	ILLINOIS TOOL WORKS, INC. SHAKEPROOF DIVISION	ST. CHARLES ROAD	ELGIN, IL 60120
78471	TILLEY MFG. CO.	900 INDUSTRIAL RD.	SAN CARLOS, CA 94070
79136	WALDES, KOHINOOR, INC.	47-16 AUSTEL PLACE	LONG ISLAND CITY, NY 11101
79807	WROUGHT WASHER MFG. CO.	2100 S. O BAY ST.	MILWAUKEE, WI 53207
80009	TEKTRONIX, INC.	P O BOX 500	BEAVERTON, OR 97077
83385	CENTRAL SCREW CO.	2530 CRESCENT DR.	BROADVIEW, IL 60153
93907	CAMCAR SCREW AND MFG. CO.	600 18TH AVE.	ROCKFORD, IL 61101

Fig. & Index No.	Tektronix Part No.	Serial/Model No. Eff	Dscont	Qty	1	2	3	4	5	Name & Description	Mfr Code	Mfr Part Number
1-1	337-1399-00			2						SHLD,ELECTRICAL:SIDE	80009	337-1399-00
-2	129-0064-04			2						POST,BDG,ELEC:CHARCOAL,5-WAY MINIATURE (ATTACHING PARTS FOR EACH)		
-3	210-0457-00			1						NUT,PLAIN,EXT W:6-32 X 0.312 INCH,STL	83385	OBD
-4	358-0181-00			1						INSULATOR,BSHG:CHARCOAL	58474	BB10166G13BX
										* - - - -		
-5	129-0064-00			1						POST,BDG,ELEC:CHARCOAL,5-WAY MINIATURE (ATTACHING PARTS)	58474	BINP BB10167G13T
-6	210-0457-00			1						NUT,PLAIN,EXT W:6-32 X 0.312 INCH,STL	83385	OBD
										* - - - -		
-7	366-1317-00			1						KNOB:RED,CAL	80009	366-1317-00
	213-0153-00			1						. SETSCREW:5-40 X 0.125 INCH,HEX SOC STL	74445	OBD
-8	366-1395-00			1						KNOB:VOLTS/DIV	80009	366-1395-00
	213-0153-00			2						. SETSCREW:5-40 X 0.125 INCH,HEX SOC STL	74445	OBD
-9	366-0494-00			1						KNOB:GRAY,POSITION	80009	366-0494-00
	213-0153-00			1						. SETSCREW:5-40 X 0.125 INCH,HEX SOC STL	74445	OBD
-10	366-1084-00			1						KNOB:GRAY,DC OFFSET FINE	80009	366-1084-00
	213-0239-00			1						. SETSCREW:3-48 X 0.062 INCH,HEX SOC STL	71159	OBD
-11	366-1101-00			1						KNOB:GRAY,DC OFFSET COARSE	80009	366-1101-00
	213-0153-00			1						. SETSCREW:5-40 X 0.125 INCH,HEX SOC STL	74445	OBD
-12	366-1257-14			1						PUSH BUTTON:GRAY--ON	80009	366-1257-14
-13	366-1257-11			2						PUSH BUTTON:GRAY--AC PRE	80009	366-1257-11
-14	366-1257-12			2						PUSH BUTTON:GRAY--CHG GND	80009	366-1257-12
-15	366-1257-74			1						PUSH BUTTON:ON	80009	366-1257-74
-16	366-1286-00	B010100	B019999	1						KNOB:LATCH	80009	366-1286-00
	366-1286-03	B020000		1						KNOB:LATCH,SILVER	80009	366-1286-03
	214-1840-00	XB020000		1						PIN,KNOB SECRCG:0.094 OD X 0.120 INCH LONG	80009	214-1840-00
-17	358-0029-00			1						BSHG,MACH.THD:HEX,0.375-32 X 0.438"LONG (ATTACHING PARTS)	80009	358-0029-00
-18	210-0590-00			1						NUT,PLAIN,HEX.:0.375 X 0.438 INCH,STL	73743	2X28269-402
-19	210-0978-00			1						WASHER,FLAT:0.375 ID X 0.50 INCH OD,STL	78471	OBD
-20	344-0195-00			1						CLIP,GROUND:		
	210-0012-00			1						WASHER,LOCK:INTL,0.375 ID X 0.50" OD STL	78189	1220-02-00-0541C
										* - - - -		
-21	-----			1						RES.,VAR NONWIR:(SEE R120 EPL) (ATTACHING PARTS)		
-22	210-0583-00			1						NUT,PLAIN,HEX.:0.25-32 X 0.312 INCH,BRS	73743	2X20224-402
-23	210-0940-00			1						WASHER,FLAT:0.25 ID X 0.375 INCH OD,STL	79807	OBD
										* - - - -		
-24	-----			1						RES.,VAR:(SEE R60A & R60B EPL) (ATTACHING PARTS)		
-25	210-0583-00			1						NUT,PLAIN,HEX.:0.25-32 X 0.312 INCH,BRS	73743	2X20224-402
-26	210-0940-00			1						WASHER,FLAT:0.25 ID X 0.375 INCH OD,STL	79807	OBD
-27	210-0046-00			1						WASHER,LOCK:INTL,0.26 ID X 0.40" OD,STL	78189	1214-05-00-0541C
										* - - - -		
-28	426-0681-00			6						FR,PUSH BUTTON:GRAY PLASTIC	80009	426-0681-00
-29	333-1531-00			1						PANEL,FRONT:	80009	333-1531-00
-30	214-1513-00	B010100	B019999	1						LCH,PL-IN RTNG:PLASTIC	80009	214-1513-00
	214-1513-01	B020000		1						LCH,PLUG-IN RET: (ATTACHING PARTS)	80009	214-1513-01
-31	213-0254-00			1						SCR,TPG,THD CTG:2-32 X 0.250,100 DEG,FLH	45722	OBD
										* - - - -		
-32	136-0429-00			1						RETAINER,LAMP:CAM SWITCH	80009	136-0429-00
-33	386-2216-00			1						SUBPANEL:FRONT (ATTACHING PARTS)	80009	386-2216-00
-34	213-0229-00			4						SCR,TPG,THD FOR:6-20 X0.375"100 DEG,FLH STL	93907	OBD
										* - - - -		
-35	337-1632-00			1						SHIELD,ELEC:REAR	80009	337-1632-00
-36	337-1430-00			1						SHIELD,LIGHT:LAMP	80009	337-1430-00
-37	384-1059-00			1						EXTENSION SHAFT:6.58 INCH LONG	80009	384-1059-00
-38	384-1099-00			1						EXTENSION SHAFT:PUSH BUTTON,1.54 INCH LONG	80009	384-1099-00
-39	-----			1						CKT BOARD ASSY:MAIN(SEE A1 EPL)		
-40	136-0235-00			1						. SOCKET,PLUG-IN:6 CONTACT,ROUND	71785	133-96-12-062

Replaceable Mechanical Parts—5A19N

Fig. & Index No.	Tektronix Part No.	Serial/Model No. Eff Dscont	Qty	1 2 3 4 5	Name & Description	Mfr Code	Mfr Part Number
1-41	131-0604-00		14	.	CONTACT,ELEC:CKT BD SW,SPR	80009	131-0604-00
-42	214-0579-00		2	.	TERM.,TEST PT:0.40 INCH LONG	80009	214-0579-00
-43	-----		1	.	SWITCH,PUSH:4PDT(SEE S130 EPL)		
-44	361-0383-00		2	.	SPACER,PB SW:CHARCOAL,0.33 INCH LONG	80009	361-0383-00
-45	-----		1	.	SWITCH,PUSH:(SEE S10A,B EPL)		
-46	-----		1	.	SWITCH,PUSH:(SEE S40A,B EPL)		
-47	-----		1	.	SWITCH,PUSH:PP,1 STA,NON-SHORT(SEE S60 EPL)		
-48	361-0384-00		10	.	SPACER,PB SW:0.133 INCH LONG	80009	361-0384-00
-49	-----		1	.	RES.,VAR NONWIR:(SEE R105 EPL)		
-50	376-0051-00	B010100 B019999	1	.	CPLG,SHAFT,FLEX:FOR 0.125 INCH DIA SHAFTS	80009	376-0051-00
	376-0051-01	B020000	1	.	CPLG,SHAFT,FLEX:FOR 0.125 INCH DIA SHAFTS	80009	376-0051-01
	376-0049-00		1	.	CPLG,SHAFT,FLEX:PLASTIC	80009	376-0049-00
	354-0251-00		2	.	RING,COUPLING:0.251 ID X 0.375 INCH OD,AL	80009	354-0251-00
	213-0022-00	B010100 B019999	4	.	SETScrew:4-40 X 0.188 INCH,HEX SOC STL	74445	OBD
	213-0178-00	B020000	4	.	SETScrew:4-40 X 0.125 INCH,HEX,SOC STL	74445	OBD
-51	384-0282-00		1	.	EXTENSION SHAFT:0.125 OD X 0.625 INCH LONG	80009	384-0282-00
-52	200-0963-00		1	.	COVER,CAM SW: (ATTACHING PARTS)	80009	200-0963-00
-53	211-0022-00		4	.	SCREW,MACHINE:2-56 X 0.188 INCH,PNH STL	83385	OBD
-54	210-0259-00		1	.	TERMINAL,LUG:0.099"ID INT TOOTH,SE	80009	210-0259-00
-55	210-0001-00		3	.	WASHER,LOCK:INTL,0.092 ID X 0.18"OD,STL	78189	1202-00-00-0541C
-56	220-0636-00		4	.	NUT,PLAIN,HEX.:2-56 X 0.188 INCH HEX,BRS - - - * - - -	73743	OBD
-57	354-0219-00		1	.	RING,RETAINING:FOR 0.25 INCH SHAFT	79136	5103-25-MD-R
-58	214-1139-00 <sup>1</sup>		-	.	SPRING,FLAT:GOLD COLORED	80009	214-1139-00
	214-1139-02 <sup>1</sup>		-	.	SPRING,FLAT:GREEN COLORED	80009	214-1139-02
	214-1139-03 <sup>1</sup>		-	.	SPRING,FLAT:RED COLORED	80009	214-1139-03
-59	214-1127-00		1	.	ROLLER,DETENT:0.125 DIA X 0.125 INCH L	80009	214-1127-00
-60	401-0057-00		1	.	BEARING,CAM SW:FRONT	80009	401-0057-00
-61	407-0653-00		1	.	BRACKET,COVER:CAM SWITCH	80009	407-0653-00
-62	105-0317-00		1	.	DRUM,CAM SW:VOLTS/DIV	80009	105-0317-00
-63	401-0056-00		1	.	BEARING,CAM SW:REAR	80009	401-0056-00
-64	210-0406-00		6	.	NUT,PLAIN,HEX.:4-40 X 0.188 INCH,BRS (ATTACHING PARTS CKT BOARD ASSY)	73743	2X12161-402
-65	211-0116-00		6	.	SCR,ASSEM WSHR:4-40 X 0.312 INCH,PNH BRS	83385	OBD
-66	213-0146-00		4	.	SCR,TPG,THD FOR:6-20 X 0.313 INCH,PNH STL - - - * - - -	83385	OBD
-67	426-0725-00		1	.	FR SECT,PLUG-IN:TOP	80009	426-0725-00
-68	426-0724-00		1	.	FR SECT,PLUG-IN:BOTTOM	80009	426-0724-00
-69	175-0826-00		FT	.	WIRE,ELECTRICAL:3 WIRE RIBBON,5 INCHES LONG	08261	OBD
-70	175-0827-00		FT	.	WIRE,ELECTRICAL:4 WIRE RIBBON,9 INCHES LONG	08261	SS-0426-710610C

<sup>1</sup>Replace only with part bearing the same color code as the original part in your instrument.

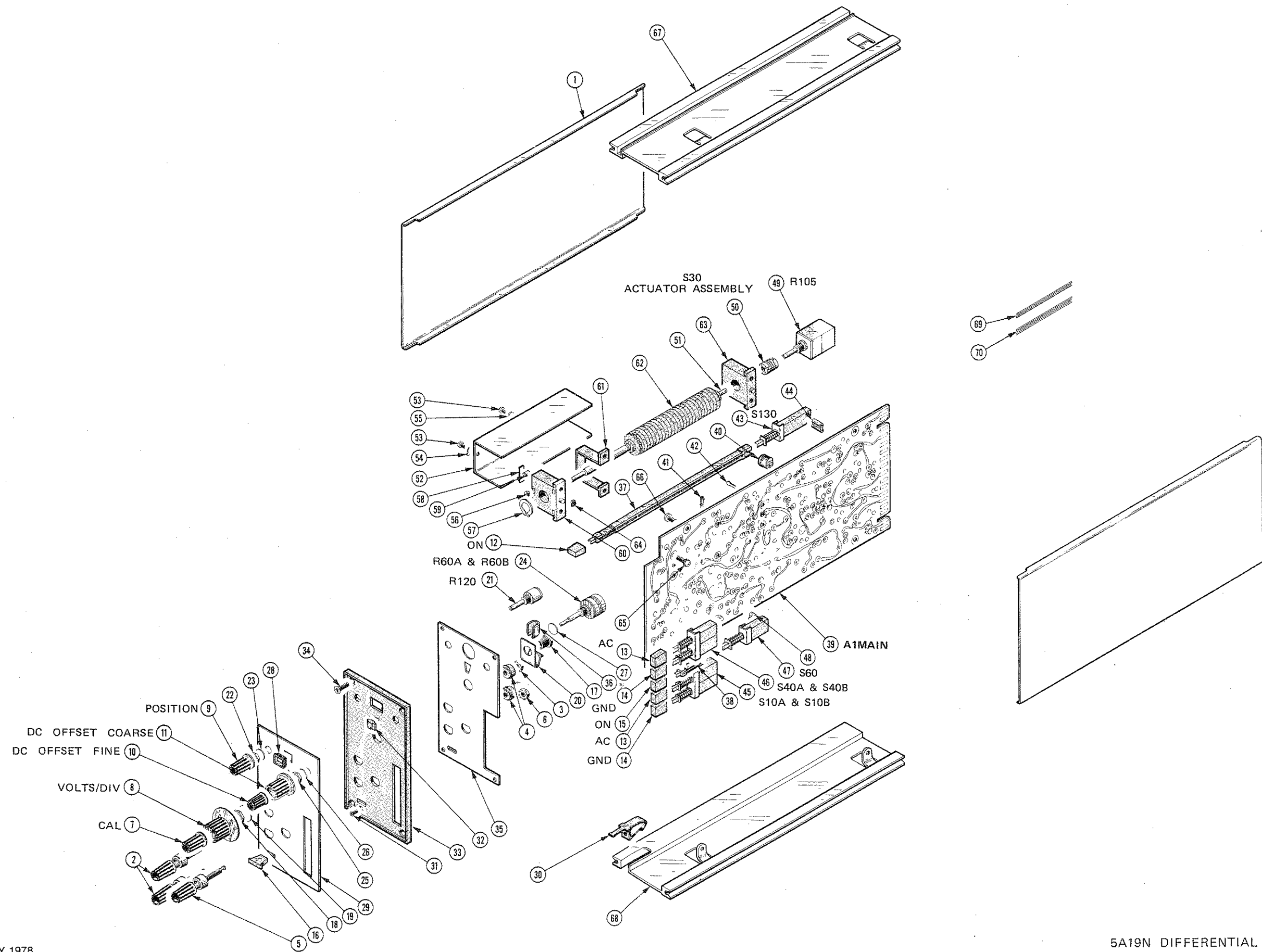



Index No.	Tektronix Part No.	Serial/Model No. Eff	Dscnt	Qty						Name & Description	Mfr	
					1	2	3	4	5		Code	Mfr Part Number
	070-1328-00			1						MANUAL, TECH: INSTRUCTION	80009	070-1328-00



## **MANUAL CHANGE INFORMATION**

At Tektronix, we continually strive to keep up with latest electronic developments by adding circuit and component improvements to our instruments as soon as they are developed and tested.

Sometimes, due to printing and shipping requirements, we can't get these changes immediately into printed manuals. Hence, your manual may contain new change information on following pages.

A single change may affect several sections. Since the change information sheets are carried in the manual until all changes are permanently entered, some duplication may occur. If no such change pages appear following this page, your manual is correct as printed.

## **SERVICE NOTE**

Because of the universal parts procurement problem, some electrical parts in your instrument may be different from those described in the Replaceable Electrical Parts List. The parts used will in no way alter or compromise the performance or reliability of this instrument. They are installed when necessary to ensure prompt delivery to the customer. Order replacement parts from the Replaceable Electrical Parts List.



# CALIBRATION TEST EQUIPMENT REPLACEMENT

## Calibration Test Equipment Chart

This chart compares TM 500 product performance to that of older Tektronix equipment. Only those characteristics where significant specification differences occur, are listed. In some cases the new instrument may not be a total functional replacement. Additional support instrumentation may be needed or a change in calibration procedure may be necessary.

### Comparison of Main Characteristics

DM 501 replaces 7D13		
PG 501 replaces 107 108	PG 501 - Risetime less than 3.5 ns into 50 $\Omega$ . PG 501 - 5 V output pulse; 3.5 ns Risetime	107 - Risetime less than 3.0 ns into 50 $\Omega$ . 108 - 10 V output pulse; 1 ns Risetime
PG 502 replaces 107 108 111	PG 502 - 5 V output PG 502 - Risetime less than 1 ns; 10 ns Pretrigger pulse delay	108 - 10 V output 111 - Risetime 0.5 ns; 30 to 250 ns Pretrigger pulse delay
PG 508 replaces 114 115 2101	Performance of replacement equipment is the same or better than equipment being replaced.	
PG 506 replaces 106 067-0502-01	PG 506 - Positive-going trigger output signal at least 1 V; High Amplitude output, 60 V. PG 506 - Does not have chopped feature.	106 - Positive and Negative-going trigger output signal, 50 ns and 1 V; High Amplitude output, 100 V. 0502-01 - Comparator output can be alternately chopped to a reference voltage.
SG 503 replaces 190, 190A, 190B 191 067-0532-01	SG 503 - Amplitude range 5 mV to 5.5 V p-p. SG 503 - Frequency range 250 kHz to 250 MHz.	190B - Amplitude range 40 mV to 10 V p-p. 0532-01 - Frequency range 65 MHz to 500 MHz.
SG 504 replaces 067-0532-01 067-0650-00	SG 504 - Frequency range 245 MHz to 1050 MHz.	0532-01 - Frequency range 65 MHz to 500 MHz.
TG 501 replaces 180, 180A 181 184 2901	TG 501 - Trigger output-slaved to marker output from 5 sec through 100 ns. One time-mark can be generated at a time. TG 501 - Trigger output-slaved to market output from 5 sec through 100 ns. One time-mark can be generated at a time. TG 501 - Trigger output-slaved to marker output from 5 sec through 100 ns. One time-mark can be generated at a time.	180A - Trigger pulses 1, 10, 100 Hz; 1, 10, and 100 kHz. Multiple time-marks can be generated simultaneously. 181 - Multiple time-marks 184 - Separate trigger pulses of 1 and 0.1 sec; 10, 1, and 0.1 ms; 10 and 1 $\mu$ s. 2901 - Separate trigger pulses, from 5 sec to 0.1 $\mu$ s. Multiple time-marks can be generated simultaneously.

NOTE: All TM 500 generator outputs are short-proof. All TM 500 plug-in instruments require TM 500-Series Power Module.

