

KEITHLEY

Model 610C, 610CR Solid-State Electrometers

Instruction Manual

A GREATER MEASURE OF CONFIDENCE

WARRANTY

Keithley Instruments, Inc. warrants this product to be free from defects in material and workmanship for a period of 1 year from date of shipment.

Keithley Instruments, Inc. warrants the following items for 90 days from the date of shipment: probes, cables, rechargeable batteries, diskettes, and documentation.

During the warranty period, we will, at our option, either repair or replace any product that proves to be defective.

To exercise this warranty, write or call your local Keithley representative, or contact Keithley headquarters in Cleveland, Ohio. You will be given prompt assistance and return instructions. Send the product, transportation prepaid, to the indicated service facility. Repairs will be made and the product returned, transportation prepaid. Repaired or replaced products are warranted for the balance of the original warranty period, or at least 90 days.

LIMITATION OF WARRANTY

This warranty does not apply to defects resulting from product modification without Keithley's express written consent, or misuse of any product or part. This warranty also does not apply to fuses, software, non-rechargeable batteries, damage from battery leakage, or problems arising from normal wear or failure to follow instructions.

THIS WARRANTY IS IN LIEU OF ALL OTHER WARRANTIES, EXPRESSED OR IMPLIED, INCLUDING ANY IMPLIED WARRANTY OF MERCHANTABILITY OR FITNESS FOR A PARTICULAR USE. THE REMEDIES PROVIDED HEREIN ARE BUYER'S SOLE AND EXCLUSIVE REMEDIES.

NEITHER KEITHLEY INSTRUMENTS, INC. NOR ANY OF ITS EMPLOYEES SHALL BE LIABLE FOR ANY DIRECT, INDIRECT, SPECIAL, INCIDENTAL OR CONSEQUENTIAL DAMAGES ARISING OUT OF THE USE OF ITS INSTRUMENTS AND SOFTWARE EVEN IF KEITHLEY INSTRUMENTS, INC., HAS BEEN ADVISED IN ADVANCE OF THE POSSIBILITY OF SUCH DAMAGES. SUCH EXCLUDED DAMAGES SHALL INCLUDE, BUT ARE NOT LIMITED TO: COSTS OF REMOVAL AND INSTALLATION, LOSSES SUSTAINED AS THE RESULT OF INJURY TO ANY PERSON, OR DAMAGE TO PROPERTY.



Keithley Instruments, Inc.

28775 Aurora Road • Cleveland, Ohio 44139 • 440-248-0400 • Fax: 440-248-6168
1-888-KEITHLEY (534-8453) • www.keithley.com

Sales Offices:	BELGIUM:	Bergensesteenweg 709 • B-1600 Sint-Pieters-Leeuw • 02-363 00 40 • Fax: 02/363 00 64
	CHINA:	Yuan Chen Xin Building, Room 705 • 12 Yumin Road, Dewai, Madian • Beijing 100029 • 8610-6202-2886 • Fax: 8610-6202-2892
	FINLAND:	Tietäjantie 2 • 02130 Espoo • Phone: 09-54 75 08 10 • Fax: 09-25 10 51 00
	FRANCE:	3, allée des Garays • 91127 Palaiseau Cédex • 01-64 53 20 20 • Fax: 01-60 11 77 26
	GERMANY:	Landsberger Strasse 65 • 82110 Germering • 089/84 93 07-40 • Fax: 089/84 93 07-34
	GREAT BRITAIN:	Unit 2 Commerce Park, Brunel Road • Theale • Berkshire RG7 4AB • 0118 929 7500 • Fax: 0118 929 7519
	INDIA:	Flat 2B, Willocrissa • 14, Rest House Crescent • Bangalore 560 001 • 91-80-509-1320/21 • Fax: 91-80-509-1322
	ITALY:	Viale San Gimignano, 38 • 20146 Milano • 02-48 39 16 01 • Fax: 02-48 30 22 74
	KOREA:	FL., URI Building • 2-14 Yangjae-Dong • Seocho-Gu, Seoul 137-130 • 82-2-574-7778 • Fax: 82-2-574-7838
	NETHERLANDS:	Postbus 559 • 4200 AN Gorinchem • 0183-635333 • Fax: 0183-630821
	SWEDEN:	c/o Regus Business Centre • Frosundaviks Allé 15, 4tr • 169 70 Solna • 08-509 04 679 • Fax: 08-655 26 10
	SWITZERLAND:	Kriesbachstrasse 4 • 8600 Dübendorf • 01-821 94 44 • Fax: 01-820 30 81
	TAIWAN:	1FL., 85 Po Ai Street • Hsinchu, Taiwan, R.O.C. • 886-3-572-9077 • Fax: 886-3-572-9031

The following safety precautions should be observed before using this product and any associated instrumentation. Although some instruments and accessories would normally be used with non-hazardous voltages, there are situations where hazardous conditions may be present.

This product is intended for use by qualified personnel who recognize shock hazards and are familiar with the safety precautions required to avoid possible injury. Read and follow all installation, operation, and maintenance information carefully before using the product. Refer to the manual for complete product specifications.

If the product is used in a manner not specified, the protection provided by the product may be impaired.

The types of product users are:

Responsible body is the individual or group responsible for the use and maintenance of equipment, for ensuring that the equipment is operated within its specifications and operating limits, and for ensuring that operators are adequately trained.

Operators use the product for its intended function. They must be trained in electrical safety procedures and proper use of the instrument. They must be protected from electric shock and contact with hazardous live circuits.

Maintenance personnel perform routine procedures on the product to keep it operating properly, for example, setting the line voltage or replacing consumable materials. Maintenance procedures are described in the manual. The procedures explicitly state if the operator may perform them. Otherwise, they should be performed only by service personnel.

Service personnel are trained to work on live circuits, and perform safe installations and repairs of products. Only properly trained service personnel may perform installation and service procedures.

Keithley products are designed for use with electrical signals that are rated Installation Category I and Installation Category II, as described in the International Electrotechnical Commission (IEC) Standard IEC 60664. Most measurement, control, and data I/O signals are Installation Category I and must not be directly connected to mains voltage or to voltage sources with high transient over-voltages. Installation Category II connections require protection for high transient over-voltages often associated with local AC mains connections. Assume all measurement, control, and data I/O connections are for connection to Category I sources unless otherwise marked or described in the Manual.

Exercise extreme caution when a shock hazard is present. Lethal voltage may be present on cable connector jacks or test fixtures. The American National Standards Institute (ANSI) states that a shock hazard exists when voltage levels greater than 30V RMS, 42.4V peak, or 60VDC are present. **A good safety practice is to expect that hazardous voltage is present in any unknown circuit before measuring.**

Operators of this product must be protected from electric shock at all times. The responsible body must ensure that operators are prevented access and/or insulated from every connection point. In some cases, connections must be exposed to potential human contact. Product operators in these circumstances must be trained to protect themselves from the risk of electric shock. If the circuit is capable of operating at or above 1000 volts, **no conductive part of the circuit may be exposed.**

Do not connect switching cards directly to unlimited power circuits. They are intended to be used with impedance limited sources. NEVER connect switching cards directly to AC mains. When connecting sources to switching cards, install protective devices to limit fault current and voltage to the card.

Before operating an instrument, make sure the line cord is connected to a properly grounded power receptacle. Inspect the connecting cables, test leads, and jumpers for possible wear, cracks, or breaks before each use.

When installing equipment where access to the main power cord is restricted, such as rack mounting, a separate main input power disconnect device must be provided, in close proximity to the equipment and within easy reach of the operator.

For maximum safety, do not touch the product, test cables, or any other instruments while power is applied to the circuit under test. ALWAYS remove power from the entire test system and discharge any capacitors before: connecting or disconnecting cables or jumpers, installing or removing switching cards, or making internal changes, such as installing or removing jumpers.

Do not touch any object that could provide a current path to the common side of the circuit under test or power line (earth) ground. Always make measurements with dry hands while standing on a dry, insulated surface capable of withstanding the voltage being measured.

The instrument and accessories must be used in accordance with its specifications and operating instructions or the safety of the equipment may be impaired.

Do not exceed the maximum signal levels of the instruments and accessories, as defined in the specifications and operating information, and as shown on the instrument or test fixture panels, or switching card.

When fuses are used in a product, replace with same type and rating for continued protection against fire hazard.

Chassis connections must only be used as shield connections for measuring circuits, NOT as safety earth ground connections.

If you are using a test fixture, keep the lid closed while power is applied to the device under test. Safe operation requires the use of a lid interlock.

If a  screw is present, connect it to safety earth ground using the wire recommended in the user documentation.

The  symbol on an instrument indicates that the user should refer to the operating instructions located in the manual.

The  symbol on an instrument shows that it can source or measure 1000 volts or more, including the combined effect of normal and common mode voltages. Use standard safety precautions to avoid personal contact with these voltages.

The **WARNING** heading in a manual explains dangers that might result in personal injury or death. Always read the associated information very carefully before performing the indicated procedure.

The **CAUTION** heading in a manual explains hazards that could damage the instrument. Such damage may invalidate the warranty.

Instrumentation and accessories shall not be connected to humans.

Before performing any maintenance, disconnect the line cord and all test cables.

To maintain protection from electric shock and fire, replacement components in mains circuits, including the power transformer, test leads, and input jacks, must be purchased from Keithley Instruments. Standard fuses, with applicable national safety approvals, may be used if the rating and type are the same. Other components that are not safety related may be purchased from other suppliers as long as they are equivalent to the original component. (Note that selected parts should be purchased only through Keithley Instruments to maintain accuracy and functionality of the product.) If you are unsure about the applicability of a replacement component, call a Keithley Instruments office for information.

To clean an instrument, use a damp cloth or mild, water based cleaner. Clean the exterior of the instrument only. Do not apply cleaner directly to the instrument or allow liquids to enter or spill on the instrument. Products that consist of a circuit board with no case or chassis (e.g., data acquisition board for installation into a computer) should never require cleaning if handled according to instructions. If the board becomes contaminated and operation is affected, the board should be returned to the factory for proper cleaning/servicing.

Model 610C, 610CR Solid-State Electrometers Instruction Manual

Keithley Instruments, Inc.
All rights reserved.
Cleveland, Ohio, U.S.A.
Third Printing, December 2001
Document Number: 29113 Rev. C

CONTENTS

<u>Section</u>	<u>Page</u>
SPECIFICATIONS	ii
1. GENERAL DESCRIPTION	1
2. OPERATION	4
3. CIRCUIT DESCRIPTION	9
4. ACCESSORIES	12
5. SERVICING	13
6. CALIBRATION	22
7. REPLACEABLE PARTS	27
SCHEMATIC	35

ILLUSTRATIONS

Figure No.	Title	Page
1	Front Panel Controls	1
2	Rear Panel Controls.	1
3	Front Panel Controls, Model 610CR.	3
4	Rear Panel Controls, Model 610CR	3
5	Guarded Voltage Measurement.	6
6	Current Measurements, Loading Error.	6
7	Galvanometric Measurements	6
8	Resistance Measurements.	6
9	Recorder Output, 100 mV Divider Network.	8
10	Voltmeter Configuration, NORMAL Mode	9
11	Ammeter Configuration, FAST Mode	11
12	Ohmmeter Configuration, NORMAL Mode.	11
13	Chassis, Side View	15
14	Chassis, Side View	16
15	Circuit Board, PC-183.	17
16	Printed Circuit Board, PC-186.	18
17	Switch, MEDIUM ZERO, S101.	19
18	Switch, COARSE ZERO, S102.	19
19	Switch, RANGE S106	20
20	Switch, Multiplier, S107	21
21	Chassis Assembly	33

Model 610C/610CR Specifications

AS A VOLTMETER

RANGE: 0.001V full scale to 100V in eleven 1× and 3× ranges.

ACCURACY: ±1% of full scale on all ranges, exclusive of noise and drift.

ZERO DRIFT: <1mV per 24 hours; <150μV per °C after 30-minute warm-up.

METER NOISE: ±25μV maximum with input shorted on most sensitive range.

INPUT IMPEDANCE: >10¹⁴Ω shunted by 20pF. Input resistance may also be selected in decade steps from 10 to 10¹¹Ω.

AS AN AMMETER

RANGE: 10⁻¹⁴A full scale to 0.3A in twenty-eight 1× and 3× ranges.

ACCURACY: ±2% of full scale on 0.3 to 10⁻¹¹A ranges using the smallest available multiplier setting; ±4% of full scale on 3 × 10⁻¹² to 10⁻¹⁴A ranges.

METER NOISE: <±3 × 10⁻¹⁵A.

OFFSET CURRENT: <5 × 10⁻¹⁵A.

AS AN AMPLIFIER

INPUT IMPEDANCE: >10¹⁴Ω shunted by 20pF. Input resistance may also be selected in decade steps from 10 to 10¹¹Ω.

OUTPUTS: Unity-gain output and either voltage or current recorder output.

UNITY-GAIN OUTPUT: At DC, output is equal to input within 10ppm, exclusive of noise and drift, for output currents ≤100μA. Up to 1mA may be drawn for input voltages ≤10V. Output polarity is the same as input polarity.

VOLTAGE RECORDER OUTPUT: ±3V for full scale input. Internal resistance is 3kΩ. Output polarity is opposite input polarity.

GAIN: 0.1, 0.3, etc. to 3000.

FREQUENCY RESPONSE (within 3db): DC to 40kHz at a gain of 1 and lower, decreasing to DC to 100Hz at maximum gain. Full output response limited to 3kHz on any gain.

NOISE: <3% rms of full scale at gain of 3000, decreasing to 1% at gains below 100.

CURRENT RECORDER OUTPUT: ±1mA for full scale input, variable ±5% with 1400Ω recorders.

AS AN OHMMETER

RANGE: 100Ω full scale to 10¹⁴Ω in 25 linear 1× and 3× ranges.

ACCURACY: ±3% of full scale on 100 to 10¹⁰Ω ranges using the largest available multiplier setting; ±5% of full scale on 3 × 10¹⁰ to 10¹⁴Ω ranges.

AS A COULOMB METER

RANGE: 10⁻¹³C full scale to 10⁻⁵C in seventeen 1× and 3× ranges.

ACCURACY: ±5% of full scale on all ranges. Drift due to offset current does not exceed 5 × 10⁻¹⁵C per second.

GENERAL

POLARITY: Meter switch selects left-zero (positive or negative) or center-zero scales. Output polarity is not reversed.

CONNECTORS:

Input: Teflon-insulated UHF; ground binding post.

Voltage or current output: Amphenol 80-PC2F.

Unity gain output, chassis ground: Binding posts.

POWER: 105–125V or 210–250V (switch selected), 50–60Hz, 10W.

LINE STABILITY: A 10% change in line voltage will cause <10μV meter deflection on all ranges.

DIMENSIONS, WEIGHT: 275mm high × 175mm wide × 290mm deep (10.75 in × 7 in × 11.5 in). Net weight 4.8kg (11 lb).

ACCESSORIES SUPPLIED: Mating input and output connectors.

Specifications subject to change without notice.

SECTION 1. GENERAL DESCRIPTION

1-1. GENERAL.

a. The Keithley Model 610C Electrometer is a versatile, completely solid-state instrument which measures a wide range of dc voltage, current, resistance and charge. The Electrometer's input resistance of greater than 10^{14} ohms is the result of extensive instrument development with high input impedance transistors. The Model 610C has all the capabilities of conventional VTVMs, but it can also make many more measurements without circuit loading.

b. The Electrometer has eleven voltage ranges from 0.001 volt full scale to 100 volts, twenty-eight current ranges from 10^{-14} ampere full scale to 0.3 ampere, twenty-five linear resistance ranges from 100 ohms full scale to 10^{14} ohms, and seventeen charge ranges from 10^{-13} coulomb full scale to 10^{-5} coulomb.

c. The Model 610C employs matched insulated-gate field-effect transistors followed by a transistor differential amplifier and complimentary output stage. A large amount of negative feedback is used for stability and accuracy.

1-2. FEATURES.

a. An important feature of the Model 610C is its excellent zero stability which permits accurate measurements with a minimum of adjustment. Zero drift is less than 1 millivolt per 24 hours. Zero offset due to temperature change is less than 150 microvolts per $^{\circ}\text{C}$, after a 30-minute warm-up. This offset, however, can easily be compensated for with the front-panel zero controls.

b. Fast warm up is an inherent characteristic of this Electrometer. It can be used well within 30 minutes of a cold start on the most sensitive range and almost immediately on less sensitive ranges.

c. Low offset current — less than 5×10^{-15} ampere — minimizing zero offset with high source resistances and permits maximum resolution when measuring current and charge.

d. Excellent overload protection without degradation of performance is obtained by use of a unique input circuit. The Model 610C Electrometer will withstand overloads up to 500 volts on most ranges without damage and has good recovery.

1-3. DIFFERENCES BETWEEN THE MODELS 610C AND 610CR.

a. The Model 610CR is the rack version of the cabinet configuration, Model 610C. The circuit, specifications, electrical parts and operating procedures for the two models are the same. Besides the outside dimensions, the main difference between them is the Model 610CR's COARSE ZERO Control is on the front panel, not on the rear panel.

b. The instructions in the Manual are for both models, although only the Model 610C is mentioned.

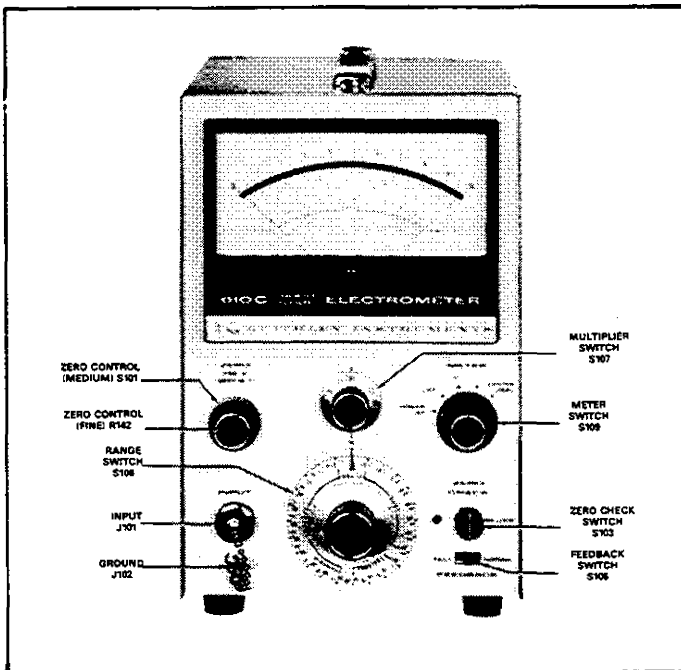

FIGURE 1. Front Panel Controls.

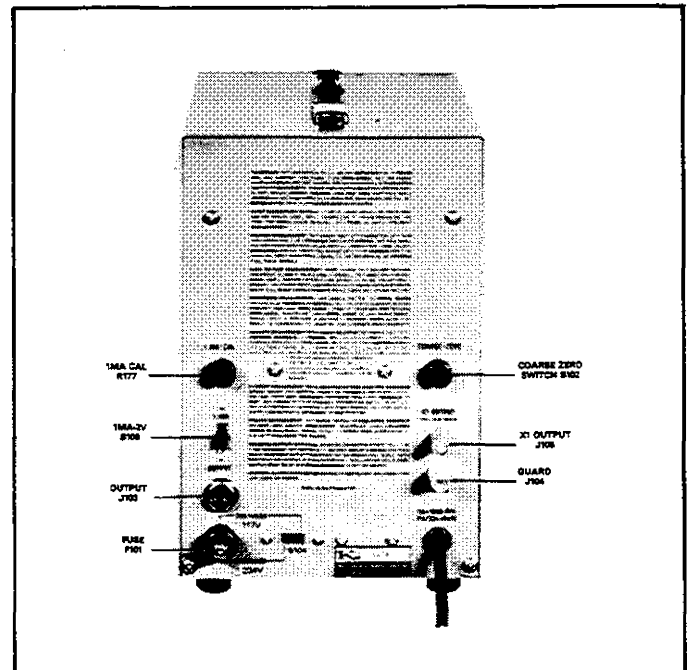

FIGURE 2. Rear Panel Controls.

TABLE 2

Front Panel Controls and Terminals

Control	Functional Description	Paragraph
<u>RANGE Switch</u> (S106)	Sets the parameter to be measured: VOLTS, AMPERES, OHMS, or COULOMBS. Also sets the particular range for a given parameter.	2-3a
<u>MULTIPLIER Switch</u> (S107)	Sets the full-scale meter sensitivity. When used with AMPERES, OHMS, or COULOMBS the setting should be multiplied by the RANGE setting.	2-3a
<u>METER Switch</u> (S109)	Controls power to instrument. Also selects the meter polarity and center scale.	2-2
<u>ZERO Controls</u>		
FINE (R142)	Meter zero adjustment. (potentiometer)	2-2
MEDIUM (S101)	Meter zero adjustment. (switch)	
COARSE (S102)	Meter zero adjustment. (switch)	
<u>ZERO CHECK Switch</u> (S103)	Zero check when depressed.	2-2
<u>FEEDBACK Switch</u> (S105)	Sets amplifier connections for NORMAL or FAST.	2-3a
<u>INPUT</u> (J101)	Input receptacle, UHF type.	2-1a
<u>GROUND</u> (J102)	Chassis ground connection.	2-1a

TABLE 3

Rear Panel Terminals

Control	Functional Description	Paragraph
OUTPUT (J103)	Output receptacle.	2-7a
1MA-3V (S108)	Sets output for 1MA or 3V full scale.	2-7a
1MA CAL (R177)	Adjusts 1MA output.	2-7a
X1 Output (J105)	Unity Gain Output.	2-7c
GUARD (J104)	Guard output.	2-5b
117-234V Switch (S104)	Sets instrument for 117 or 234V power.	2-2
Fuse (F101)	117V: 0.25A, slow blow 234V: 0.125A, slow blow	2-2

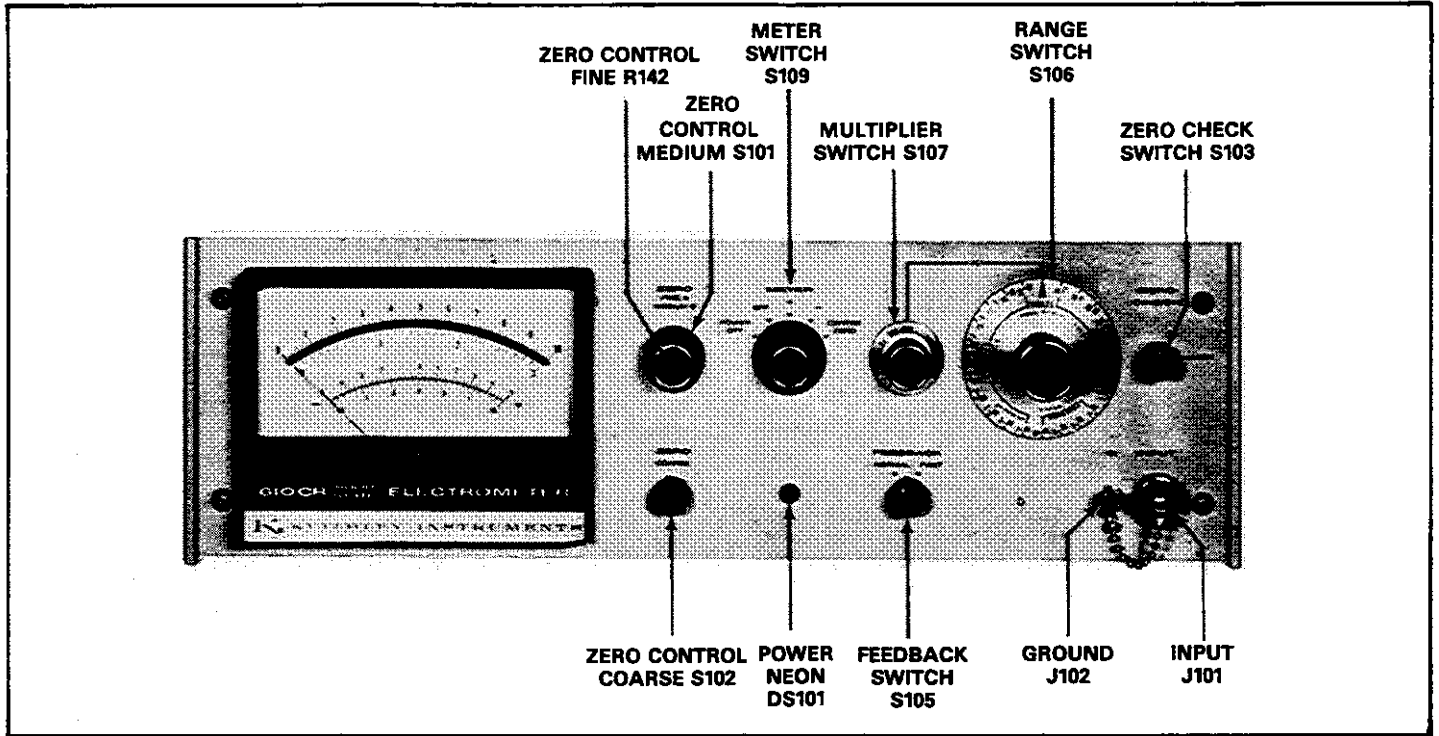

FIGURE 3. Front Panel Controls, Model 610CR.

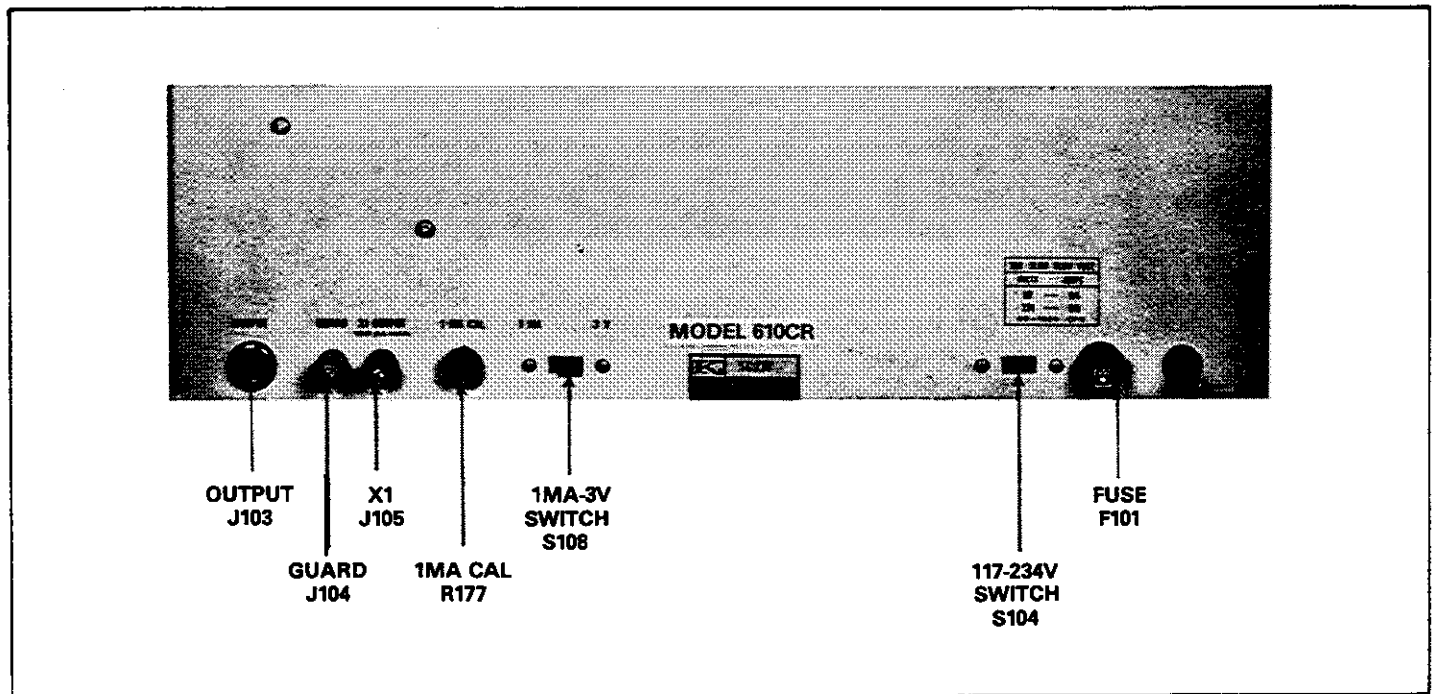

FIGURE 4. Rear Panel Controls, Model 610CR.

SECTION 2. OPERATION

2-1. INPUT CONNECTIONS.

a. The Model 610C INPUT Receptacle is a Teflon-insulated UHF-type connector. A shield cap is provided. The Ground Post, below the Receptacle, is connected to Chassis ground.

b. When working with a high impedance source, carefully shield the input connection and the source since any variation in the electrostatic field near the input will cause definite meter disturbances.

c. Use high resistance, low-loss materials — such as Teflon (recommended), polyethylene or polystyrene — for insulation. The insulation leakage resistance of test fixtures and leads should be several orders of magnitude higher than the internal resistance of the source. Excessive leakage reduces the accuracy of reading from high impedance sources. Coaxial cables used should be a low noise type which employs a graphite or other conductive coating between the dielectric and the surrounding shield braid.

NOTE

Clean, dry connections and cables are very important to maintain the value of all insulation materials. Even the best insulation will be compromised by dirt, dust, solder flux, films of oil or water vapor. A good cleaning agent is methyl alcohol, which dissolves most common dirt without chemically attacking the insulation. Dry the cables or connections after washing with alcohol or use dry nitrogen if available. Or, if it is available, Freon is an excellent cleaning agent.

d. When working with a high impedance source, any change in the shunt capacitance of the input circuit will cause disturbances in the reading. Make the measuring setup as rigid as possible, and tie down connecting cables to prevent their movement. A continuous vibration may appear at the output as a sinusoidal signal, and other precautions may be necessary to isolate the instrument and the connecting cable from the vibration.

e. For low impedance measurements — below 10^8 ohms or above 10^{-8} ampere — unshielded leads and a binding post adapter may be used.

f. When the Model 610C is used on the most sensitive current range with the FEEDBACK Switch at FAST, some insulators — such as Teflon — may produce random signals which show up as erratic meter deflections. Insulation used in the Model 610C is carefully selected to minimize these spurious signals.

g. If a well shielded chamber and a well made high impedance transfer switch is available, it is advantageous to connect the Model 610C to the circuit only when a reading is being made. In some cases, the offset current can charge the external test circuitry. One example of this occurs when measuring a capacitor's leakage resistance by observing the decay of the terminal voltage. If the leakage current is less than the offset current (less than 5×10^{-15} ampere), there may be no decay of the terminal voltage when the Electrometer is left connected across the capacitor's terminals.

IMPORTANT

Make certain that the OUTPUT SWITCH S108 (1mA-3V) is set to the "3V" position unless a 1mA recorder is connected at J103.

2-2. PRELIMINARY PROCEDURES.

a. Check the 117-234V Switch and the Fuse for the proper ac line voltage.

b. Set the controls as follows:

ZERO CHECK Button	LOCK
Range Switch	VOLTS
Multiplier Switch	1
FEEDBACK Switch	NORMAL
METER Switch	POWER OFF
1mA-3V Switch	3V

c. Connect the power cord and turn the METER Switch to CENTER ZERO. Within ten seconds, the meter pointer should come to the center position. If not, adjust the meter zero with the MEDIUM and FINE ZERO Controls. Normally, there is no need to use the COARSE ZERO Switch.

d. After a few moments increase the voltage sensitivity by advancing the Multiplier Switch to .3, .1, etc. Continue zeroing with the FINE ZERO Control.

e. After long periods of storage or after an overload, the Model 610C may drift excessively. The input transistors are insensitive to mechanical shock; however, a severe input overload may cause a zero offset. This is corrected with the Zero controls. Drifting, though, can occur for several hours.

f. Although the offset current of the Electrometer is much below that found in conventional voltmeters, it can be observed on the meter. The current charges the input capacitance, and the Electrometer appears to drift when the input is open. Use the ZERO CHECK Button to discharge the charge build-up.

2-3. VOLTAGE MEASUREMENTS.

a. Normal Voltage Measurements. When the RANGE switch is set to VOLTS position the 610C can be used to measure voltages from .001 volt full scale to 100 volts. In this mode the input impedance is greater than 10^{14} ohms shunted by 20 picofarads. The input impedance can be reduced when necessary by setting the RANGE switch to AMPERES as discussed in paragraph 2-3c.

1. Set the controls as follows:

ZERO CHECK Switch	LOCK
RANGE Switch	VOLTS
Multiplier Switch	100
FEEDBACK Switch	NORMAL
METER Switch	CENTER ZERO

2. Connect the input source to the UHF input. Unlock the ZERO CHECK switch to make a reading. Increase the meter sensitivity using the Multiplier switch to obtain a useable on-scale reading. The METER switch should be set to either + or - to obtain the rated voltage accuracy.

b. Guarded Voltage Measurements. This method is useable when a Keithley Model 6108 input cable is available. The Model 6108 is a specialized triaxial cable with a mating UHF connector. The cable is terminated with three color-coded alligator clip leads. The leads are identified as shown in Table 4.

TABLE 4.
Model 6108 Input Cable.

Lead Color	Terminal Function
Red	Input High
Black	Inner Shield (Guard)
Green	Outer Shield (Ground)

1. Set the controls as follows:

ZERO CHECK Switch	LOCK
RANGE Switch	VOLTS
Multiplier Switch	100
FEEDBACK Switch	NORMAL
METER Switch	CENTER ZERO

2. Connect the Model 6108 to the UHF input. Connect the black banana plug to the X1 OUTPUT on the rear panel of the instrument. Connect the remaining alligator clip leads as shown in Figure 5.

c. Decreased Input Resistance. The input resistance can be reduced for applications where very high input resistance is not required. Set the RANGE switch to one of the AMPERES ranges where the input is shunted by a resistor. The input resistance is then the reciprocal value of the AMPERES setting. For instance, to obtain an input resistance of 10 megohms ($10^7 \Omega$) set the RANGE switch to the 10^{-7} AMPERES range. Then adjust the Multiplier switch to the full scale voltage desired. The 610C can now be used for voltage measurements as discussed in paragraphs 2-3a and b.

d. High Voltage Measurements. Measurements can be made up to 30 kilovolts using one of the Voltage Divider probes listed in Table 5. The full scale voltage range is determined by multiplying the divider ratio times the Multiplier setting.

TABLE 5
Voltage Divider Probes

Model	Divider Ratio	Accuracy
6102A	10:1	$\pm 4\%$
6103A	1000:1	$\pm 5\%$ at 10 kv

2-4. CURRENT MEASUREMENTS.

a. Normal Current Measurements. When the FEEDBACK switch is set to NORMAL the current is determined by measuring the voltage drop across a RANGE resistor shunting the 610C input. This method is useable for any current range where low noise is essential.

1. Set the front panel controls as follows:

ZERO CHECK Switch	LOCK
RANGE Switch	10^{-1} AMPERES
Multiplier Switch	1
FEEDBACK Switch	NORMAL
METER Switch	CENTER ZERO

2. Connect the 610C input terminals in series with the current to be measured. Unlock the ZERO CHECK switch to make a reading. Increase the sensitivity using the RANGE switch. The full scale current is determined by multiplying the RANGE setting times the Multiplier setting. Use the smallest Multiplier setting to obtain the best accuracy. The input voltage drop of the 610C in the NORMAL mode is a function of the Multiplier setting and therefore the loading error should be noted as shown in Figure 6.

TABLE 6.

Response Speed For Fast Current Measurements.

Range	Rise Time (Seconds)			Output Noise (Peak-to-Peak)		
	No C	50pF	5000pF	No C	50pF	5000pF
10^{-14} to 10^{-11}	2.0	2.0	2.0	6×10^{-15}	1.5×10^{-14}	7×10^{-13}
10^{-10}	.45	.45	.45	8.5×10^{-14}	2×10^{-13}	2.5×10^{-12}
10^{-9}	.07	.07	.07	6.8×10^{-13}	3.2×10^{-12}	2×10^{-11}
10^{-8}	.015	.015	.015	6×10^{-12}	2.5×10^{-11}	2×10^{-10}
10^{-7}	.003	.003	.003	4×10^{-11}	8×10^{-11}	3×10^{-10}
10^{-6}	.003	.003	.003	1.5×10^{-10}	3.3×10^{-10}	8.5×10^{-10}

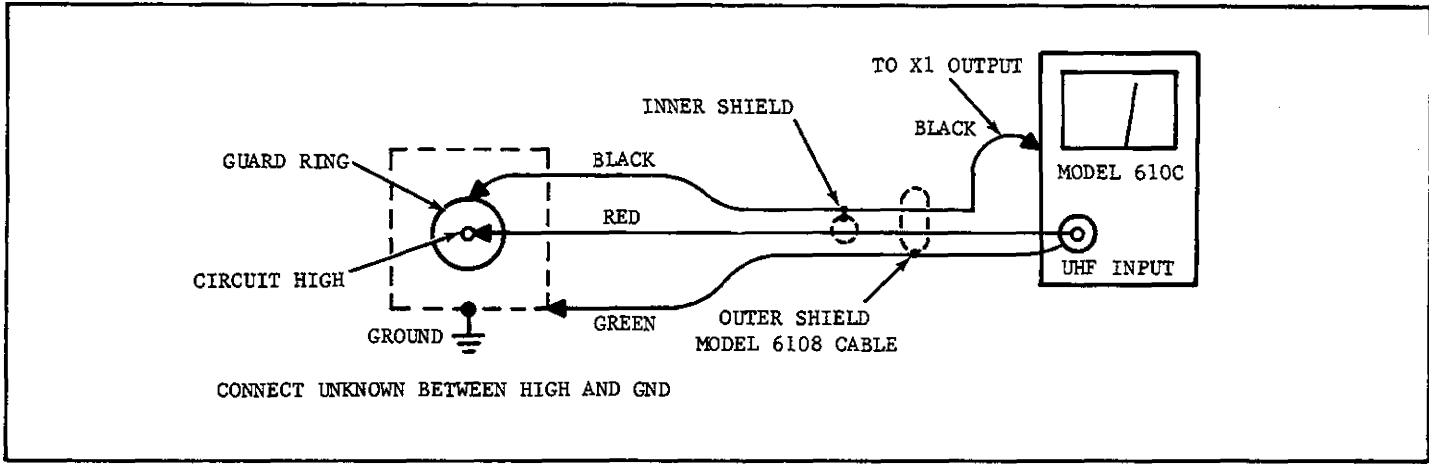

FIGURE 5. Guarded Voltage Measurement

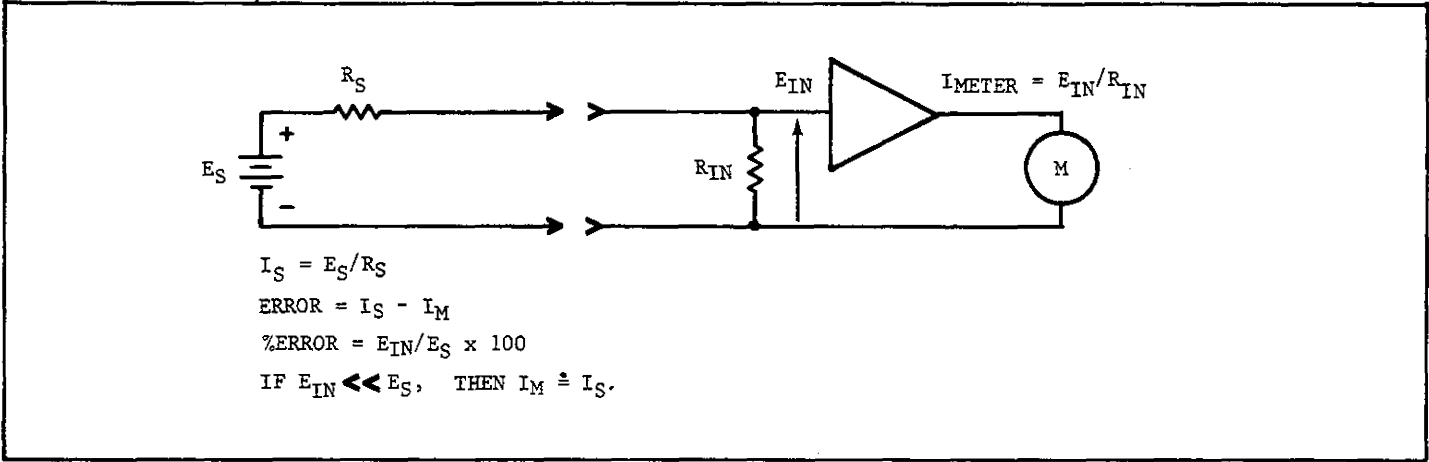

FIGURE 6. Current Measurements, Loading Error.

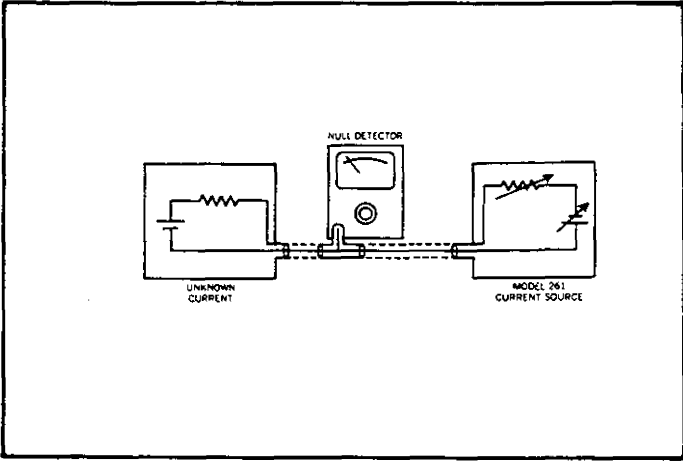

FIGURE 7. Galvanometric Measurements.

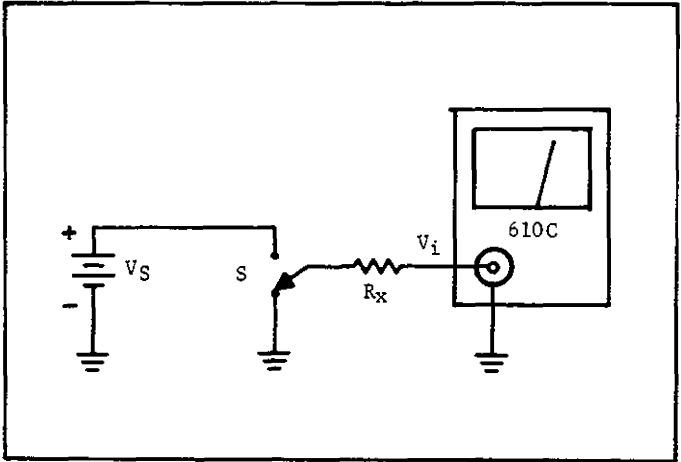

FIGURE 8. Resistance Measurements.

NOTE

If the voltage applied to the sample is not 100 times the Electrometer input drop, then the unknown resistance is calculated as follows:

$$R_x = \frac{V_{\text{Source}} - V_{\text{Input Drop}}}{I_{\text{Measured}}} \quad \text{Eq. 1}$$

where R_x = Unknown resistance,
 V_{Source} = Applied voltage,
 $V_{\text{Input Drop}}$ = Electrometer input voltage drop
 and I_{Measured} = Current measured by Electrometer.

b. Fast Current Measurements. When the FEEDBACK switch is set to FAST the current is determined by the voltage developed across the RANGE resistor in feedback loop. This method is useable for current levels from 10^{-5} to 10^{-14} amperes. Typical rise times for the 610C when used in the FAST mode are given in Table 6.

1. Set the controls as follows:

ZERO CHECK	LOCK
RANGE Switch	10^{-6} AMPERES
MULTIPLIER Switch	1
FEEDBACK Switch	FAST
METER Switch	CENTER ZERO

2. Connect the 610C input terminals in series with the current to be measured. Unlock the ZERO CHECK Switch to make a reading. Increase the sensitivity using the RANGE switch. The full scale current is determined by multiplying the RANGE setting times the MULTIPLIER setting. Use the smallest Multiplier setting to obtain the best accuracy. Example: A Multiplier setting of 0.1 means that the meter will read 0.1 Volts maximum.

3. When using the OUTPUT the recorder cannot be referenced to case ground since the low side of the output is floating.

c. Galvanometric Current Measurements. In this method the 610C is used as a null detector. The 610C should be used in conjunction with an accurate current source such as the Keithley Model 261 as shown in Figure 7.

2-5. RESISTANCE MEASUREMENTS.

a. Normal Resistance Measurements. When the FEEDBACK switch is set to NORMAL the resistance is determined by measuring the voltage drop across the unknown resistance shunting the input. The 610C injects a constant current at the input terminals. The voltage drop is therefore proportional to resistance.

b. Ohms Guard Resistance Measurements. The 610C can also be used in the FAST mode when the unknown resistance is connected between INPUT high and GUARD on the rear panel of the instrument. This method is recommended for measurements from 10^{11} to 10^{14} ohms.

c. Volt-Ampere Resistance Measurements. This method is useful when the voltage drop across the unknown resistance must be accurately controlled. For this measurement the 610C is used in the NORMAL mode with the RANGE switch set to AMPERES. The circuit connections are shown in Figure 8. To determine the resistance the Multiplier setting should be subtracted from the voltage source setting. The resistance is therefore the ratio of the net voltage divided by the current measured by the 610C.

CAUTION

The Model 610C ohms circuit has a compliance voltage to 125 volts. This means that up to 125 volts will be present at input HI and near panel X1 if the ZERO CHECK switch is OFF and input HI and LO is open-circuited. Always set ZERO CHECK to ON before connecting or disconnecting to the input when using the OHMS function.

2-6. CHARGE MEASUREMENTS.

a. Current Integration. Charge or current integration measurements can be accomplished using the 610C in the coulombmeter mode. The electrometer indicates the voltage developed across a capacitor connected between the input and feedback point. The voltage indicated is proportional to the integral of the applied current.

1. Set the controls as follows:

ZERO CHECK Switch	LOCK
RANGE Switch	10^{-7} COULOMBS
Multiplier Switch	1
FEEDBACK Switch	FAST

2. Connect the 610C input terminals in series with the current to be measured. Unlock the ZERO CHECK switch to make a reading. Increase the sensitivity using the RANGE switch. The coulombmeter reading is determined by multiplying the meter reading times the RANGE switch COULOMBS setting.

NOTE

The input offset current of the electrometer contributes a charge of 5×10^{-15} coulomb per second and should be subtracted from the actual reading.

3. After each coulombmeter reading is made, discharge the integrating capacitor in the electrometer by locking the ZERO CHECK switch for at least 20 seconds before making another measurement.

NOTE

For a more complete discussion of current integration, request the Keithley Product Note entitled "Using the Electrometer Voltmeter as a Current Integrating or Charge Measuring Instrument."

b. Static Charge Measurements. Static charge can be measured using the 610C when used with either Keithley accessory Models 2501 or 2503 Static Detector probes. In this application the 610C is used in the VOLTS mode. The charge is measured in terms of volts using the capacitive divider of the Static Detector.

NOTE

For information concerning Static Charge measurements, request the Product Note entitled "Electrometer Static Charge Measurements". The Model 610C should be used with Keithley Models 2501 and 2503 Static Detector Probes for Static Charge Measurements. Do not attempt to use the Model 610C in the COULOMBS mode for Static Charge measurements since the Electrometer is very sensitive to charge transients.

2-7. RECORDER OUTPUTS.

a. Analog Output (J103). This output can be used to monitor the 610C using either voltage or current responding recorders.

1. Voltage Output: +3 volts for full scale input. Internal resistance is 3 kilohms. Output polarity is opposite input polarity. To use this output set the IMA-3V switch to 3V. This output is suitable for use with voltage recorders, oscilloscopes, digital voltmeters, etc. which have at least 300 kilohms input resistance.

NOTE

In the FAST mode the OUTPUT is floating with respect to chassis ground.

2. Current Output: +1 milliampere for full scale input, variable +5% with 1400 ohm recorders. To use this output set the IMA-3V switch to IMA. This output is suitable for use with recorders which respond to current such as the Keithley Model 370 Recorder. The IMA CAL (R177) can be used to set full scale for the particular recorder in use.

b. Servo Rebalance Recorder Output. For some types of recorders a divider network is required to provide a 50mV or 100mV full scale output. In this application the IMA-3V switch should be set to IMA. The divider resistors should be selected to provide a voltage suitable for the recorder in use. A typical example is shown in Figure 9. The full voltage output is 3V. Therefore, the total divider resistance should be 3000 ohms. The voltage drop across the 100Ω resistor is then adjusted for 100mV by adjusting the IMA CAL control.

c. Unity-Gain Output (J105). This output can be used for measurements from very high source impedance. The XI output is equal to input within 10ppm at d-c, exclusive of noise and drift, for output currents not exceeding 100 microamperes. Output polarity is the same as input polarity. This terminal cannot be used in FAST mode.

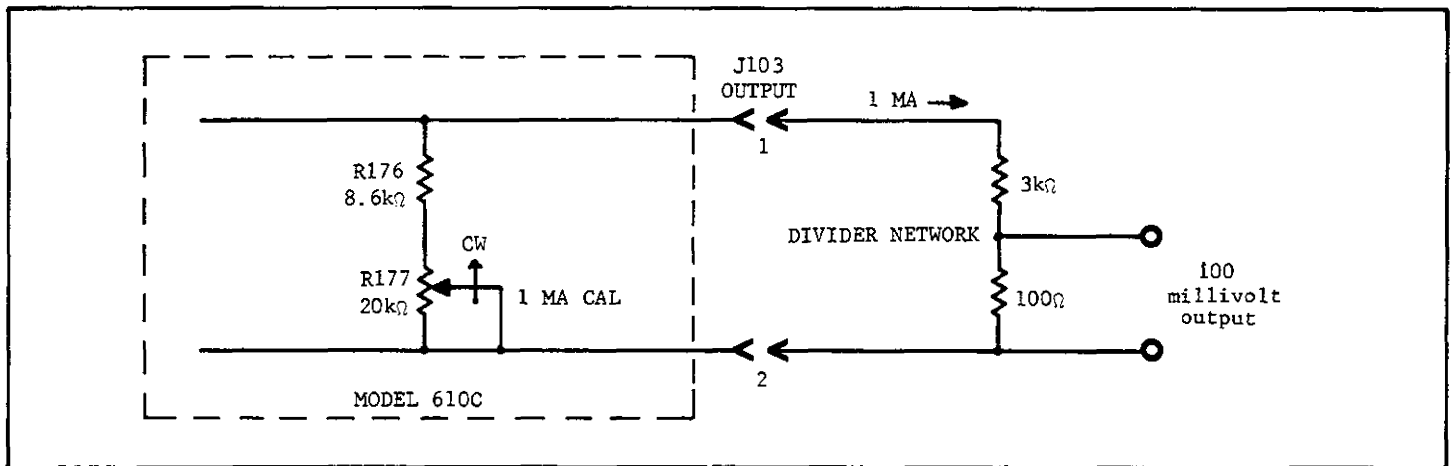

FIGURE 9. Recorder Output, 100 mV Divider Network.

SECTION 3. CIRCUIT DESCRIPTION

3-1. GENERAL.

a. The Keithley Model 610C is basically an extremely stable and linear dc voltmeter with a full-scale sensitivity of 1 millivolt and an input impedance of 10^{14} ohms shunted by 20 picofarads. By using the front panel controls, shunt resistors and capacitors are selected to make measurements over a total of 79 voltage, current, resistance, and coulomb ranges. Current and resistance are measured using precision resistance standards, from 10 ohm wirewound resistors to 10^{11} ohm glass-sealed, deposited carbon resistors. Coulombs are measured using close tolerance polystyrene film capacitor standards.

b. Well-regulated low and high voltage supplies furnish necessary amplifier power.

3-2. VOLTMETER OPERATION.

a. The Model 610C employs matched insulated-gate field-effect transistors followed by a transistor differential amplifier with a high-voltage complementary-output stage. Figure 10 shows the block diagram for the voltmeter mode of operation.

b. Voltmeter operation of the Model 610C is as follows:

1. The amplifier is always in a unity-gain, input-voltage to output current converter configuration. The internal circuitry is arranged such that a full-scale input voltage (e_i) results in exactly a 1 milliampere output current, through the divider string composed of R_m , R_{178} , and the meter. Voltage gain of the circuit is determined by the ratio of R_{178} to R_m . Output is taken across R_{178} .

2. The voltage drop across the amplifier is

$$e_a = \frac{e_i}{k+1}$$

where k is the amplifier loop gain, greater than 10^6 on all ranges.

c. The complementary-output stage, Q111 and Q112, drives the amplifier ground at the same potential as the input signal. Thus the input impedance is maintained for any value input voltage and the need for input dividers is eliminated. The amplifier ground is not chassis ground, but it is connected directly to J105, the unity-gain output.

d. Power supplies are floating with respect to chassis ground. The ± 120 volt supplies are provided for the complementary-output, Q111 and Q112, while the regulated ± 9 volt supplies provide power for the amplifier and are referred to the unity-gain output.

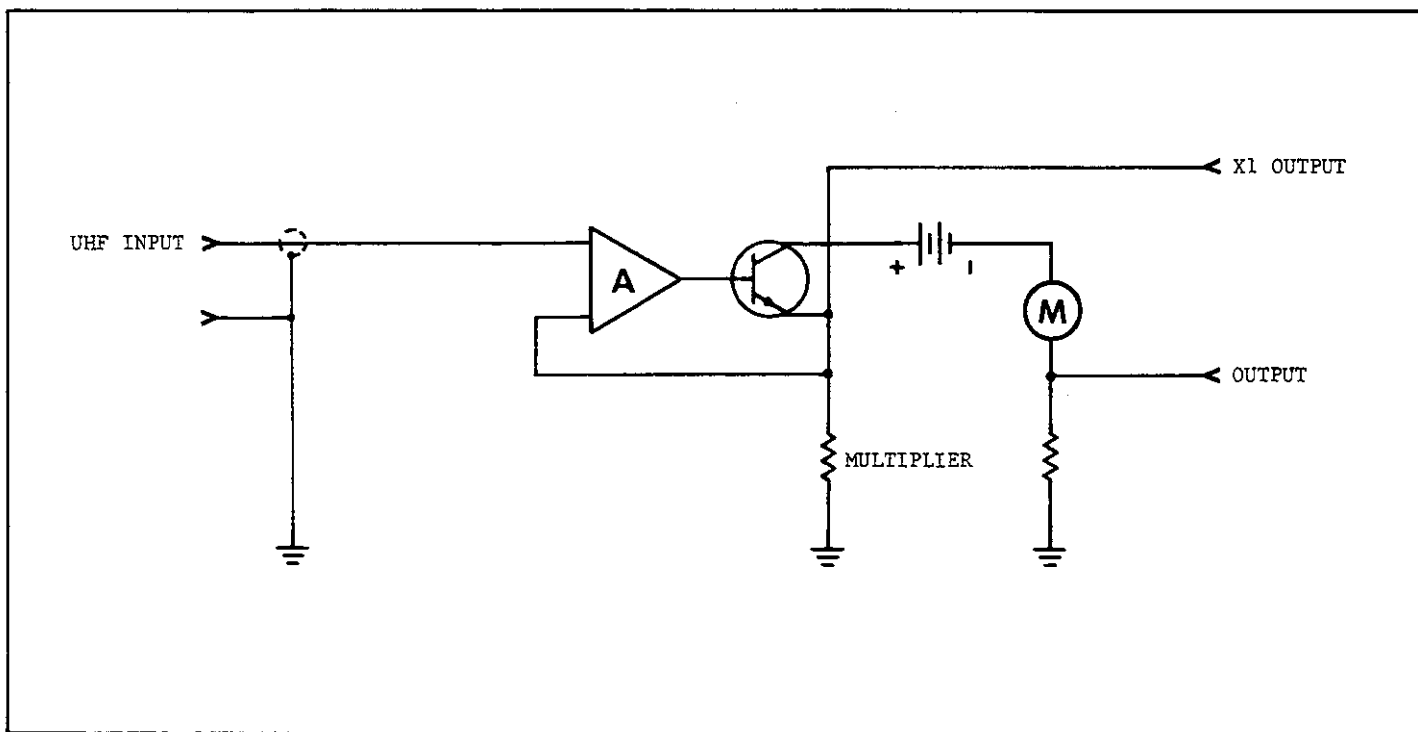

FIGURE 10. Voltmeter Configuration, NORMAL Mode.

3-3. VOLTMETER CIRCUIT.

a. The amplifier input stage is a pair of insulated-gate, field-effect transistors, Q101 and Q102, in a differential configuration. The gate of Q102 is returned to amplifier common, the unity-gain output.

b. Depressing the ZERO CHECK Button, S103, places the gate of the active insulated-gate devices at zero potential.

c. The input stage is followed by a transistor differential amplifier composed of Q103-Q110. Q108 and Q109 make up the output gain stage, which is utilized in a gain-multiplier configuration. This stage provides the remainder of the high gain required by the amplifier. Also, this stage prevents fold-over and lock-up with positive input overloads. Diode D101, between base and emitter of Q110, prevents fold-over and lock-up under negative input overloads.

d. Frequency compensation is provided by capacitors C114, C115, resistors R145, R148, and capacitor C116. The compensation networks provide a controlled frequency characteristic to insure stability under all conditions of capacitive loading on input and output while on any range.

e. The recorder output is derived from the current flow from Q111 and Q112 through the divider, R_m , R178, and the meter. With the Output Switch, S108, on 3V, ± 3 volts for full-scale deflection is obtained at output connector, J103, by ± 1.1 milliamperes flowing through the divider. With S108 at 1MA, R176 and R177 are connected across J103, allowing ± 1 milliamperes, $\pm 5\%$, to pass through an external load.

3-4. AMMETER OPERATION.

a. Normal Method. In the normal method of current measurements (FEEDBACK Switch in NORMAL position), one of the Range Switch resistors, R102 through R112, shunts the input. (See Figure 11). The Model 610C then measures the voltage drop across the resistor. The meter is calibrated to read the current in amperes for the appropriate range.

b. Fast Method. In the fast method of current measurements (FEEDBACK Switch in FAST position), the Model 610C functions as an ammeter with negative feedback. The differential amplifier output is divided by the Multiplier Switch resistors, R165 to R175, and fed back to the amplifier input through a feedback resistor selected with the Range Switch. (See Figure 11). Floating ground is connected to the low impedance side of the input, and the output ground is floating. This method increases the response speed by minimizing the effects of input capacity; it also reduces the input drop to less than 100 microvolts.

3-5. OHMMETER OPERATION.

a. Normal Method. In the normal method of resistance measurements (FEEDBACK Switch in NORMAL position), the Model 610C uses a constant-current, voltage-drop circuit. Refer to Figure 12. R_x is the unknown resistor. A voltage source, E, applies a potential across R_x . The source is obtained from the +9 volt supply through the resistor divider network, R136 through R138. E varies from 0.1 to 1.3 volts, depending upon the OHMS range used. The voltage source is connected between floating ground and the input gate of Q101 through R_s , the range resistor. R_s is one of the resistors, R102 through R112. I is equal to E/R_s , regardless of the value of R_x , as long as the voltage drop across R_x does not exceed the Multiplier Switch setting. This circuit provides a true source regardless of the input. The Model 610C can then measure the voltage drop across R_x and indicate the resistance value on its calibrated meter.

b. Guarded Method. In the guarded method of resistance measurements (FEEDBACK Switch in FAST position and the sample resistance connected between the input terminal, J101, and the OHMS Guard terminal, J104), feedback is applied through the sample. The circuit is similar to the normal method, except for the feedback. This reduces the slowing effect of the instrument's input capacity. Leakage error is also reduced since the potential across the input terminal is small. In this mode, floating ground is connected to the low impedance side of the input and the output ground is floating. The guard terminal is at output ground potential.

3-6. COULOMBMETER OPERATION. The Model 610C circuit for measuring charge is similar to that used for an ammeter with the fast method. A negative feedback is applied around a shunt capacitor, C108 to C111, selected with the Range Switch. The shunt capacitor replaces R_s in Figure 11. The stored charge is proportional to the voltage across the capacitor, which is measured by the Model 610C voltmeter circuits.

3-7. POWER SUPPLY. The power supply operates from the line voltage and furnishes ± 120 and ± 9 volts to the differential amplifier and output stages.

a. A 24-volts rms output from the transformer, T101, is full-wave rectified by diodes D110 through D113. The resultant 30 volts is filtered by capacitors C117 and C118 and regulated to ± 9 volts by diodes D102 through D105.

b. The ± 120 volts is obtained similarly through filtering and regulating by capacitors C119 and C120, and diodes D108 and D109.

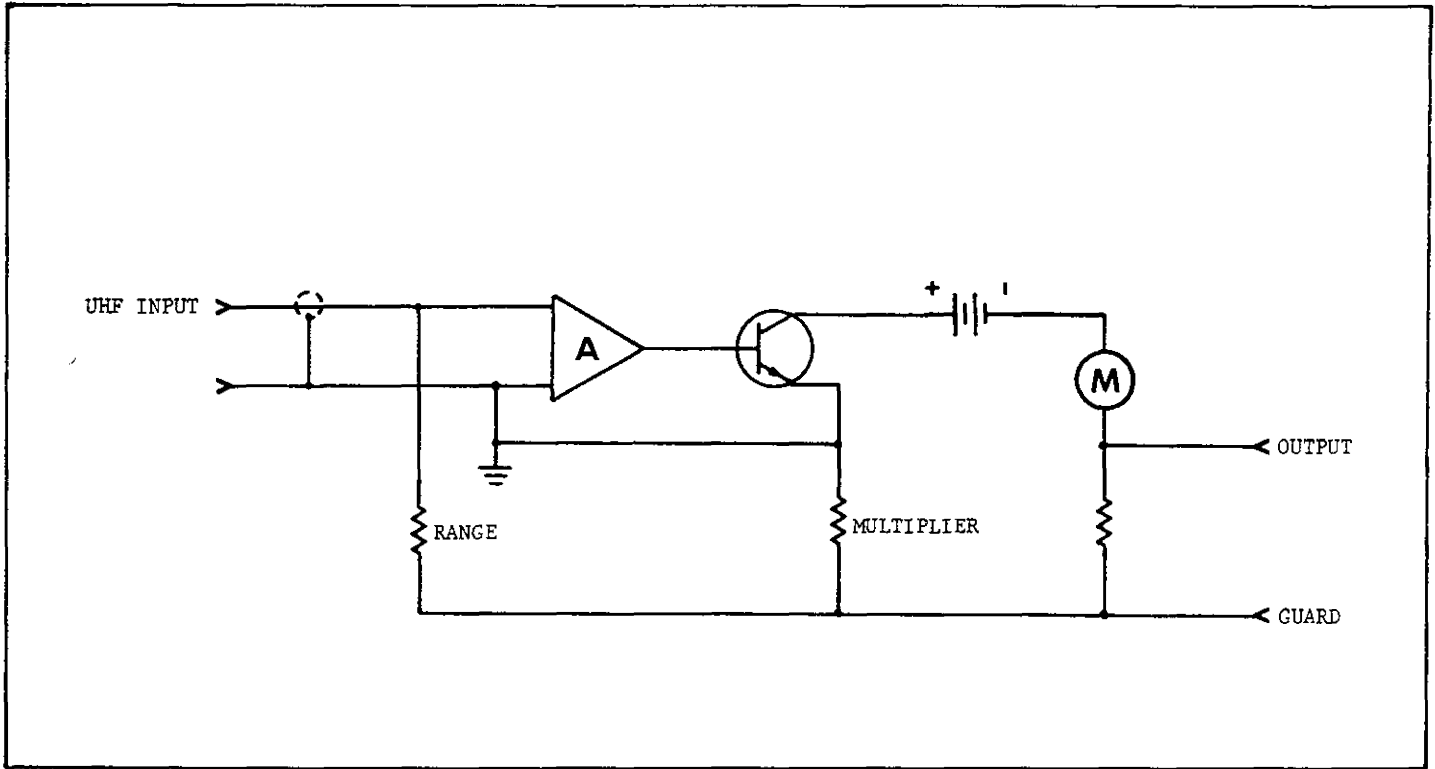

FIGURE 11. Ammeter Configuration, FAST Mode.

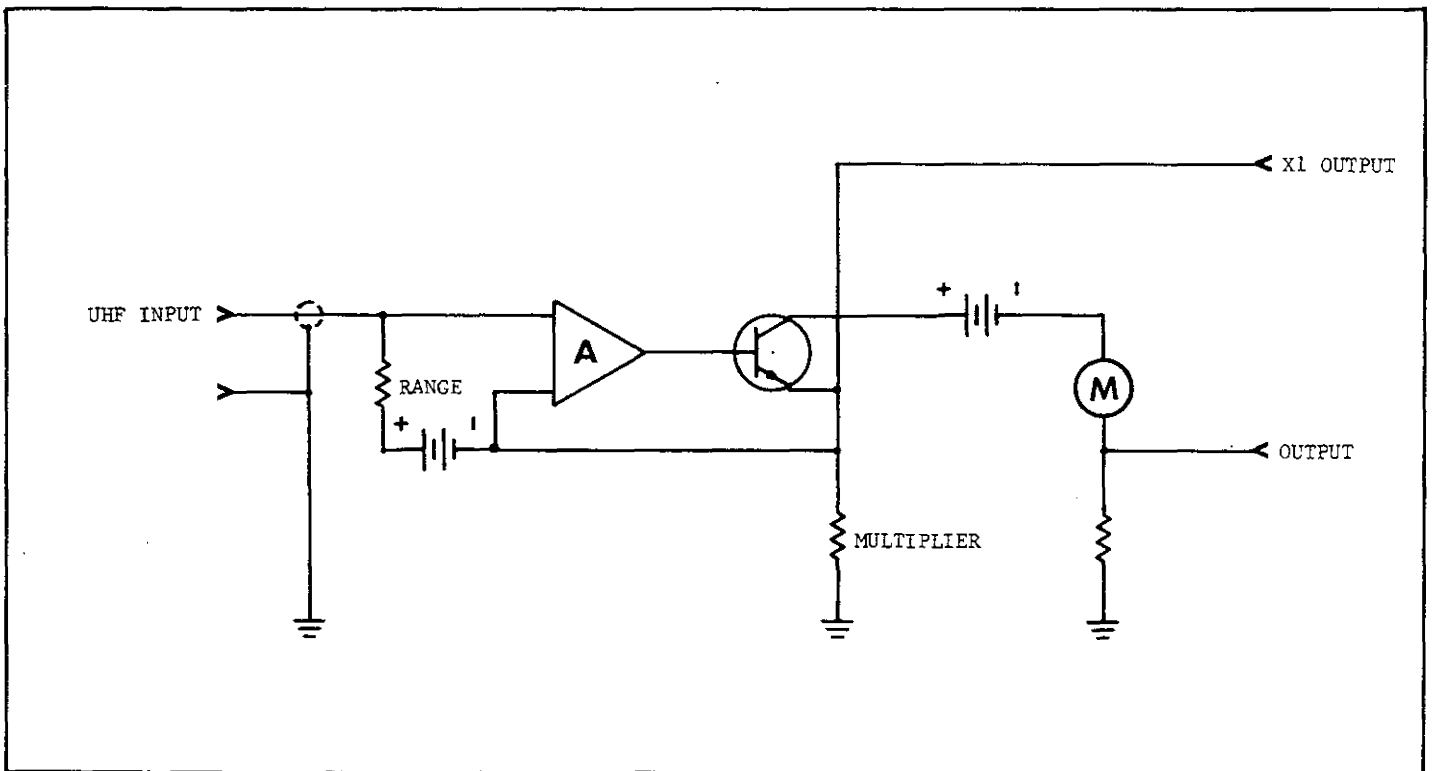

FIGURE 12. Ohmmeter Configuration, NORMAL Mode.

SECTION 4. ACCESSORIES

4-1. GENERAL. The following Keithley accessories can be used with the Model 610C to provide additional convenience and versatility.

4-2. OPERATING INSTRUCTIONS. A separate instruction manual is supplied with each accessory giving complete operating information.

Model 2503 Static Detector Probe

The Model 2503 is a specially designed detector used to measure static charge on plane surfaces. The probe must be used with an electrometer such as the 610C.

The Model 2503 is useful for measurements of charge on flat surfaces. The Model 2503 is a solid coax $\frac{1}{2}$ inch (13mm) diameter tube with a $3\frac{1}{2}$ inch (89mm) head, a $3\frac{1}{2}$ inch (89mm) coupler, a 1 inch (25mm) adapter, and two 90° angle adapters with a diameter of at least $\frac{1}{2}$ inch or 13mm. Recommended spacing is $\frac{1}{4}$ of an inch from the surface for 10,000:1 divider ratio. The 2503 is calibrated such that a one volt deflection on the electrometer corresponds to 10kV of static charge.

Model 6101A Shielded Probe

The Model 6101A is a shielded cable with a needle-point probe and 30 inches of low noise cable terminated by a UHF connector.

Model 6103C Divider Probe

The Model 6103C is a shielded cable with a needle-point probe and 30 inches of low noise cable terminated by a UHF connector. The probe includes a 1000:1 voltage divider with a $3.8 \times 10^{11}\Omega$ input resistance. Accuracy is $\pm 5\%$ of reading.

Model 6105 Resistivity Chamber

The Model 6105 is a guarded test fixture for measurement of surface and volume resistivity. The chamber is designed in accordance with ASTM Standard Method of Test for Electrical Resistance of Insulating Materials, D257-66. The 6105 can be used in conjunction with an electrometer and voltage supply.

Resistivity can be determined by measuring the current through a sample with a known voltage impressed. The measurement can be made most conveniently when a set of electrodes are used that can be calibrated in terms of surface or volume resistivity. The Keithley Model 6105 resistivity adapter has been designed for use with a Keithley electrometer and an optional high voltage supply. Mating cables are supplied as follows:

- Model 32418 UHF to MHV cable
- Model 4801 BNC to BNC cable
- Model 6147 BNC to Triax adapter
- Model CS-115 UHF to BNC adapter

Model 8002A High Resistance Test Fixture

The Model 8002A high resistance test fixture has one pair of 5-way binding posts (input) and a 3-lug female triax receptacle (output).

The Model 8002A minimizes leakage current that can become a significant portion of high resistance measurement.

Accessories:

- Model 7172 2-lug to 3-lug triaxial adapter
- Model 7078-TRX-3 three feet triaxial cable
- Model 8007-GND-3 safety ground wire
- Model CS-662 mating plug
- Model CA-18-1 dual banana cable

Model 19072 Input Cable

The Model 19072 is three feet (0.9m) of coaxial cable (SC-9). The cable is terminated with a UHF connector on one end and alligator clips on the other.

SECTION 5. SERVICING

5-1. GENERAL. Section 5 contains the maintenance and troubleshooting procedures for the Model 610C Electrometer. Follow these procedures as closely as possible to maintain the performance of the instrument.

5-2. SERVICING SCHEDULE. The Model 610C requires no periodic maintenance beyond the normal care required of high-quality electronic equipment. The value of the high-megohm resistors, R110, R111 and R112, should be checked approximately every 2 or 3 years for specified accuracy.

5-3. PARTS REPLACEMENT.

a. The Replaceable Parts List in Section 7 describes the electrical components of the Electrometer. Replace components only as necessary. Use only reliable replacements which meet the specifications.

b. The MOS FET input transistors, Q101 and Q102, are specially selected and matched; order only as a plug-in unit, part number 23733A from Keithley Instruments, Inc. They can be checked only by replacement.

TABLE 6.
Test Equipment.

Type	Description	Mfr.	Model No.
Digital Voltmeter	1 μ V to 1000V	Keithley	160 or 163
AC VTVM	-	Hewlett-Packard	400
RMS Voltmeter	-	" "	3400A
Microvolt-Ammeter	10 μ V to 1000V, 10 ⁻¹ to 10 ⁻¹¹ A	Keithley	153
Voltage Supply	0-1000V	"	241
Nanovolt Source	10 ⁻¹⁰ V to 1.11V	"	260
Picoampere Source	10 ⁻¹⁴ A to 1.1 x 10 ⁻⁴ A	"	261
Recorder	1mA type	"	370
Megohm Bridge	10 ⁵ to 10 ¹⁵ Ω	"	515A
Resistance Standards	10 ⁸ to 10 ¹³ Ω	"	5155
Differential Voltmeter	10 μ V to 500V	"	662
Oscilloscope	-	Tektronix	561A
Function Generator	-	Wavetek	102

TABLE 7. Model 610C Troubleshooting.

Difficulty	Probable Cause	Solution
Excessive zero offset	Input transistors may be defective.	Check Q101 and Q102; replace if faulty.
Excessive offset current	Excessive temperature fluctuation or defective input transistors.	Check Q101 and Q102; replace if faulty.
Cannot meter zero on any range.	See paragraph 5-5.	See paragraph 5-5e, Step 7.
Unable to zero meter on most sensitive range.	Incorrect base voltage on input transistors.	Check per paragraph 5-5.
Meter will not zero on one Multiplier Switch setting.	Faulty resistor for setting of Multiplier Switch.	Check resistors; replace if faulty.
10 ⁻¹⁰ to 10 ⁻¹⁴ ampere current ranges are out of specification.	Defective high megohm resistors.	Check per paragraph 6-10.

5-4. TROUBLESHOOTING.

a. The procedures which follow give instructions for repairing troubles which might occur in the Model 610C. Use the procedures outlined and use only specified replacement parts. Table 6 lists equipment recommended for troubleshooting. If the trouble cannot be readily located or repaired, contact Keithley Instruments, Inc., or its representatives.

b. Table 7 contains the more common troubles which might occur. If the repairs indicated in the table do not clear up the trouble, find the difficulty through a circuit-by-circuit check, such as given in paragraph 4-5. Refer to the circuit schematic to find the more critical components and to determine their function in the circuit. The complete circuit schematic, 22821E, is in Section 7.

5-5. PROCEDURES TO GUIDE TROUBLESHOOTING.

a. If the instrument will not operate, check the fuse, line cord and power source. If these are found satisfactory, use the following procedures to isolate the trouble.

b. The schematic diagram indicates all transistor terminal voltages referenced to either floating ground or output ground; a properly operating Electrometer will have these values $\pm 10\%$. The control settings for these values are the Range Switch at VOLTS, Multiplier Switch at 1, and the meter zeroed. Measurements are with the Model 153.

c. At times, the meter will not zero on any range with the input shorted. Adjust the COARSE ZERO Switch, S102 (Figure 2), to bring the Model 610C into balance. If this does not work, continue to check the circuits.

d. Power Supply.

1. Check the plus and minus 120 volt supplies with a Model 160 DVM and a Model 561A Oscilloscope to within 10% of the indicated schematic value.

a) Vary the line voltage from 105 to 125 volts

for a 117 volt line and from 210 to 250 volts for a 234 volt line. The ± 120 volt supplies should change by less than 2 volts. Return the line voltage to nominal value.

b) The ripple on the ± 120 volt supplies should be less than 40 mV peak-to-peak. If the ripple is high (up to approximately 0.3 volts peak-to-peak), check the output noise on the 1 millivolt range before attempting any corrective action. If the noise is within specification, 90 mV rms, the high ripple is acceptable. If the noise is out of specifications, try replacing the applicable zener diode to reduce ripple.

c) If replacing zener does not correct the high ripple, the probable cause is high beta in Q111 and/or Q112. Select for a beta range of 35-80.

d) High ripple on the ± 120 volt supply may also be due to a defective D114 diode in the center zero circuitry.

e) Line transients (spikes) may or may not be present depending upon machinery in operation at the time.

2. Check the plus and minus 9 volt supplies in the same manner on the ± 120 volt supplies. The ripple for the ± 9 volt supplies must be less than 4 mV peak-to-peak.

e. Amplifier.

1. To check the amplifier, disconnect the feedback loop by removing the complimentary input transistors Q111 and Q112. This allows each stage of the amplifier to be individually checked. It also eliminates the possibility of applying excessive voltage to the input transistors, causing serious damage.

2. Connect the Model 153 between the drains of Q101 and Q102. Adjust the COARSE and MEDIUM ZERO Controls for null. If a null cannot be reached, check Q101, Q102, the COARSE and MEDIUM ZERO Control circuits (resistors R114 to R135), and transistors

Q103 and Q104. Check Q103 and Q104 by removing them and adjusting again for null. If null is now reached, replace the transistor pair with a new pair.

3. Check the next stage by connecting the Model 153 across the emitters of Q103 and Q104 and adjusting the COARSE and MEDIUM ZERO Controls for null. If null is not reached, check this stage and the base circuit of the next stage. Check the base circuit by removing transistors Q105 and Q106 and again adjusting for null. If null is now reached, replace the transistor pair with a new pair.

4. Check the next stage by connecting Model 153 across the collectors of Q105 and Q106 and adjusting the COARSE and MEDIUM ZERO Controls for null. If null is not reached, check this stage and check for

shorts in the base circuit of Q107 and Q108.

5. Connect Model 153 to the collector of Q109. Adjust the FINE ZERO Control for null. If null is reached, the dc amplifier is operating correctly and the trouble is in output stage or the feedback stage.

6. Check the output stage, resistors R155 through R158 and capacitor C116 for possible shorts.

7. The feedback loop includes the multiplier resistors, R165 through R175, the recorder output resistors, R178 on 3V position or R176 and R177 on 1 MA position, and the meter. An opening of any of these components prevents zeroing of the meter. An open multiplier resistor, however, prevents zeroing for only that particular multiplier setting.

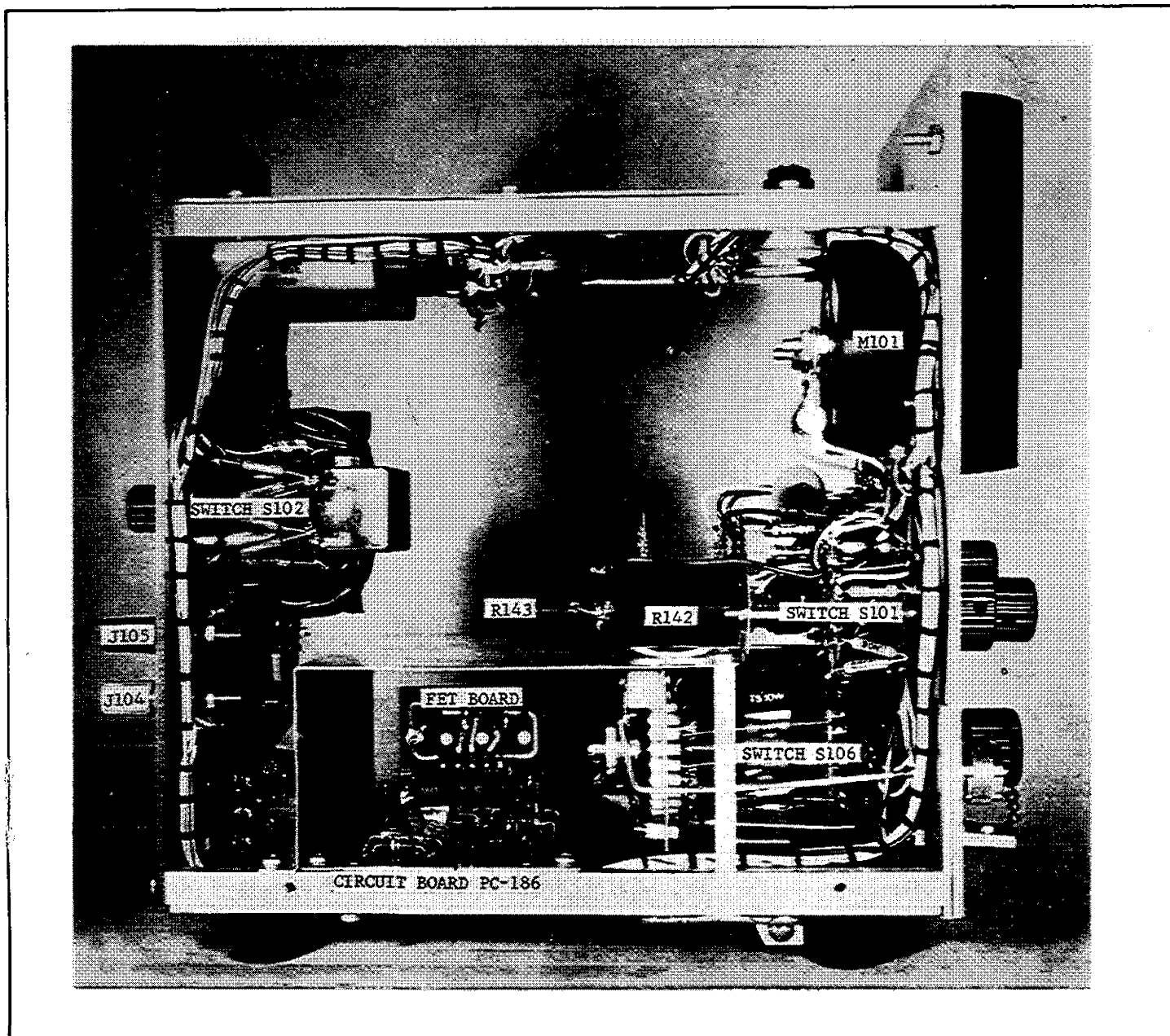

FIGURE 13. Chassis, Side View.

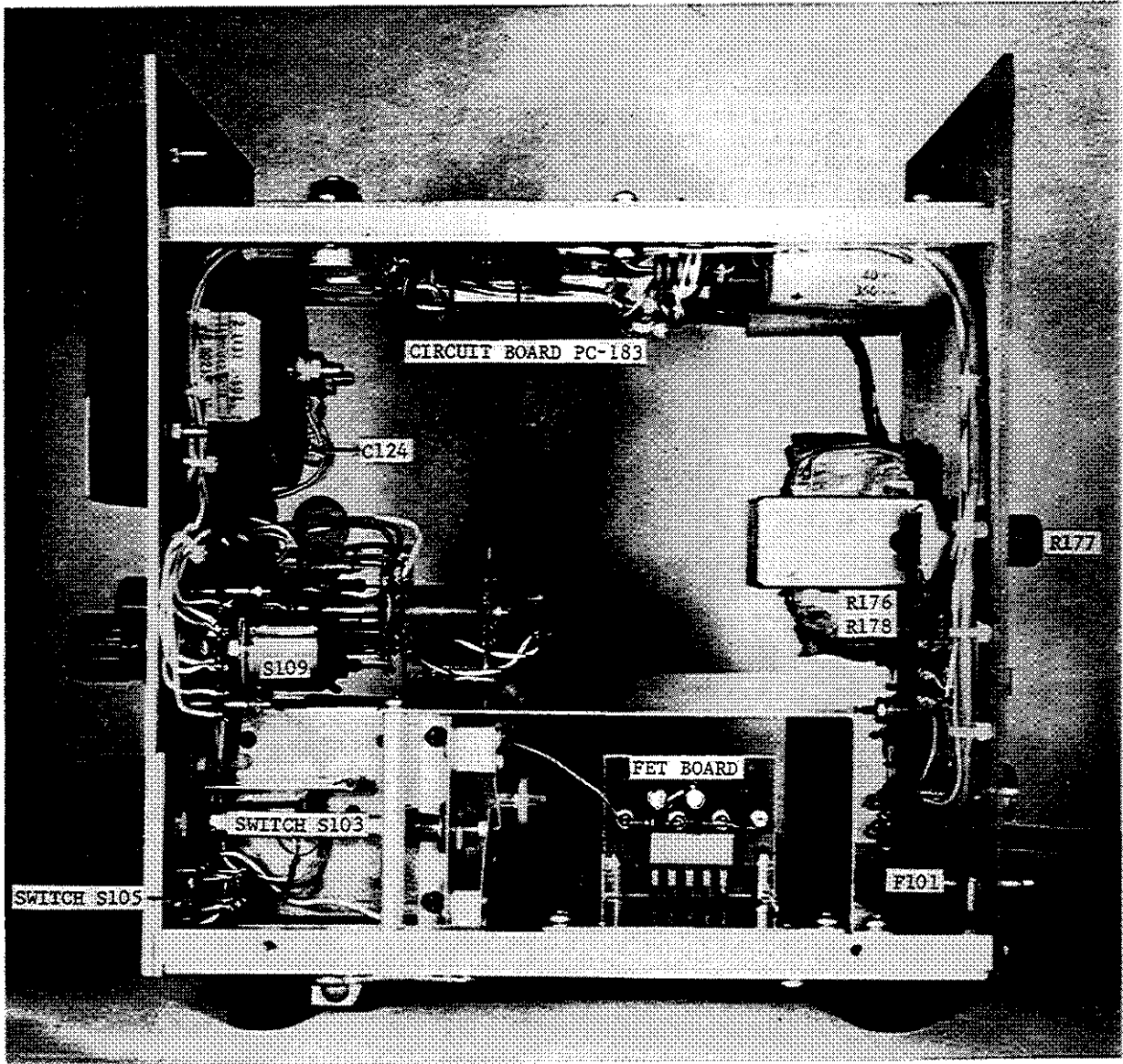

FIGURE 14. Chassis, Side View.

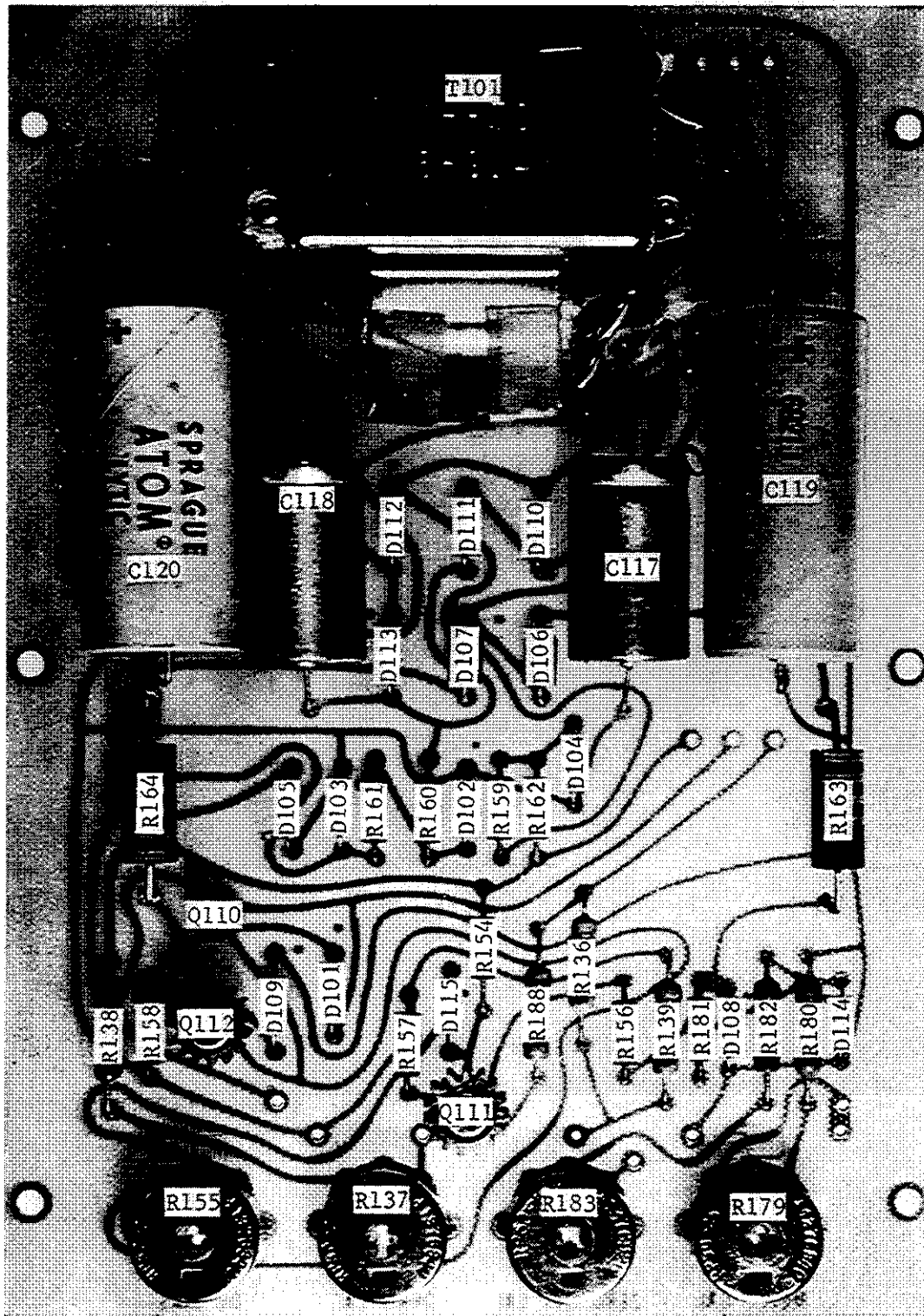

FIGURE 15. Circuit Board, PC183.

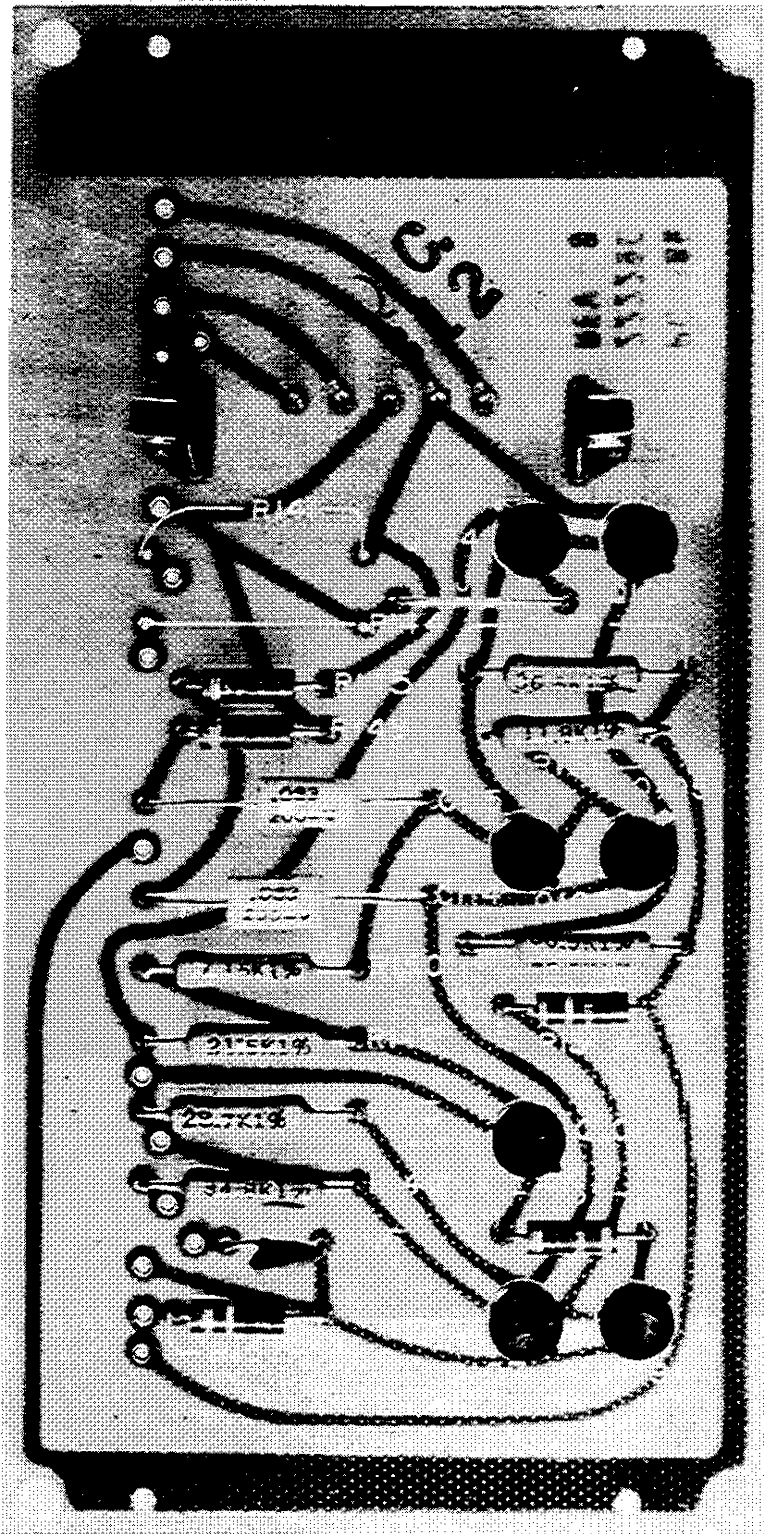

FIGURE 16. Printed Circuit Board, PC-186.

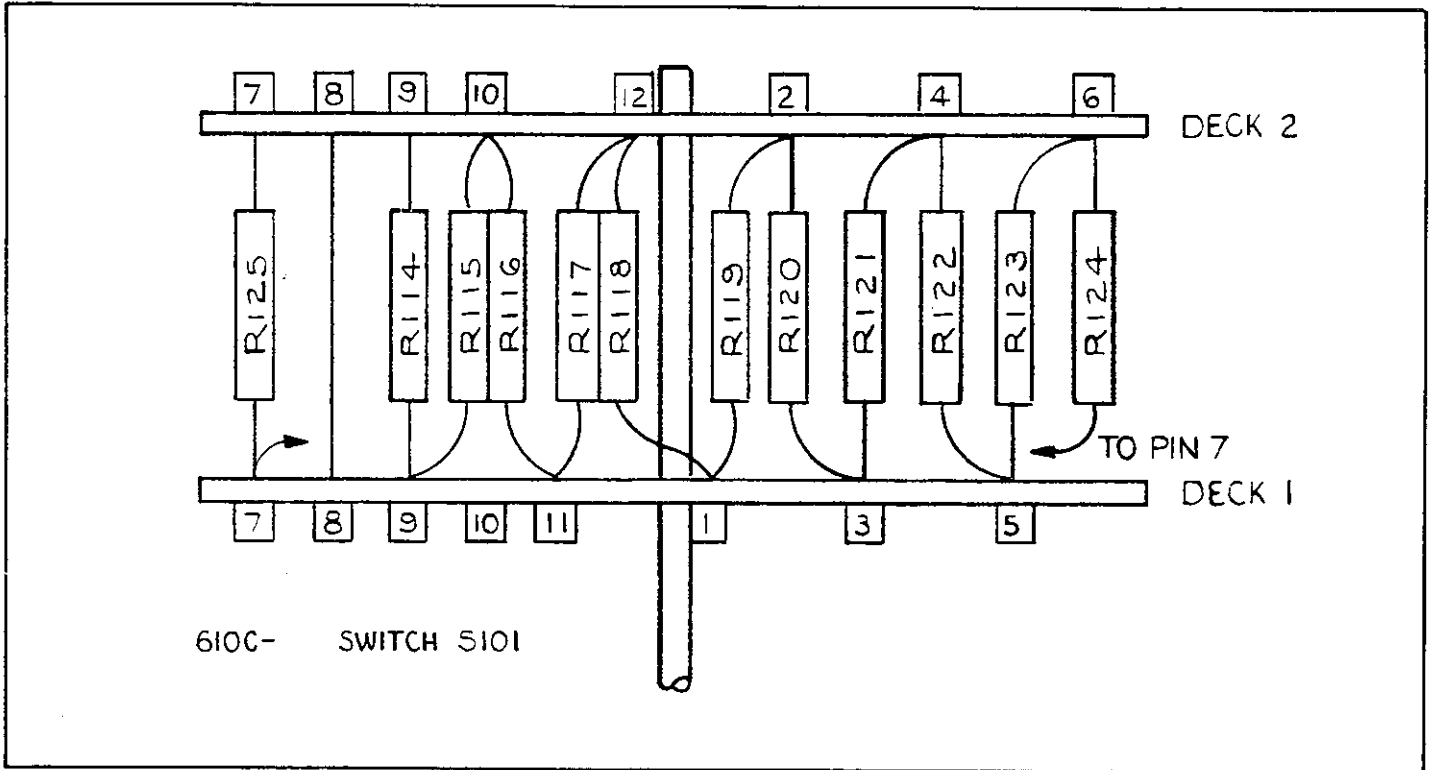

FIGURE 17. Switch, MEDIUM ZERO, S101.

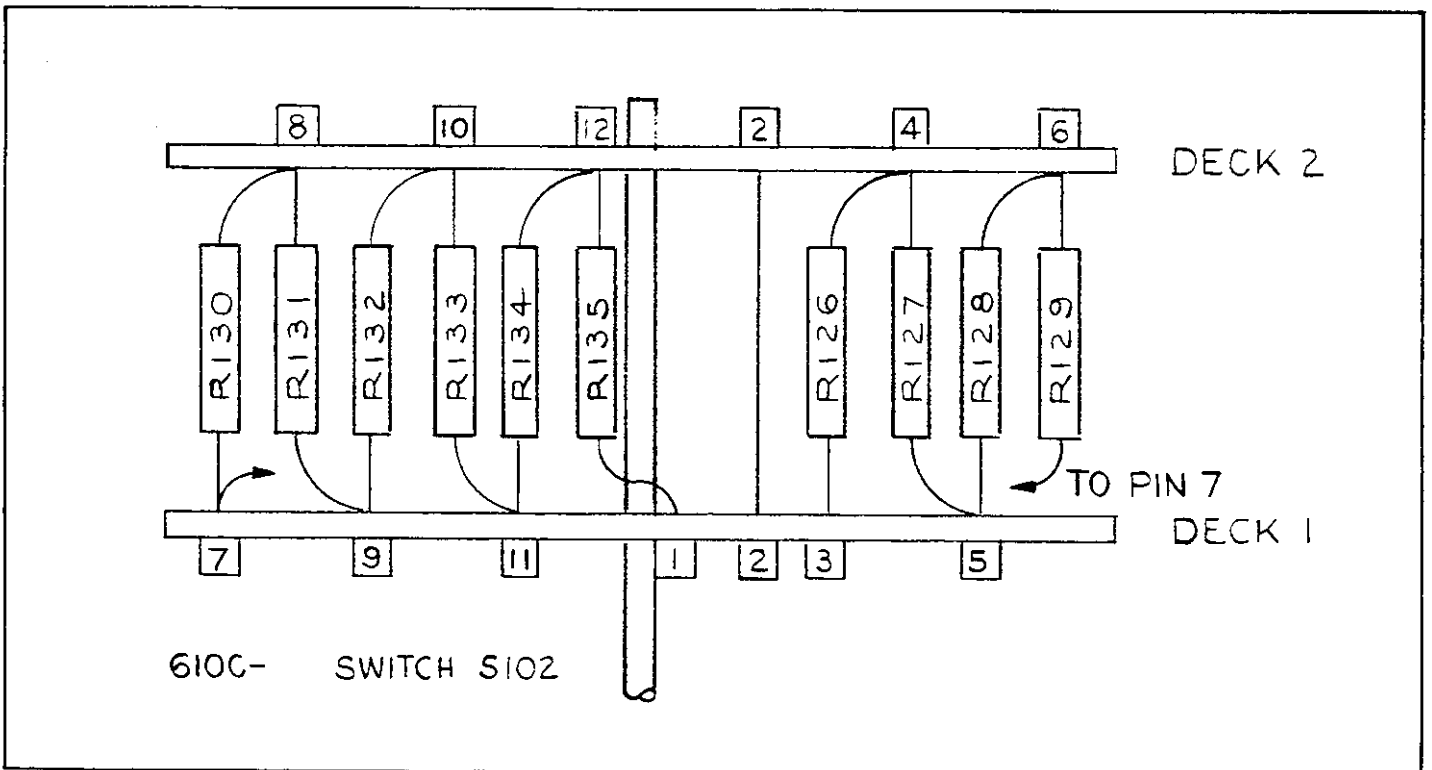

FIGURE 18. Switch, COARSE ZERO, S102.

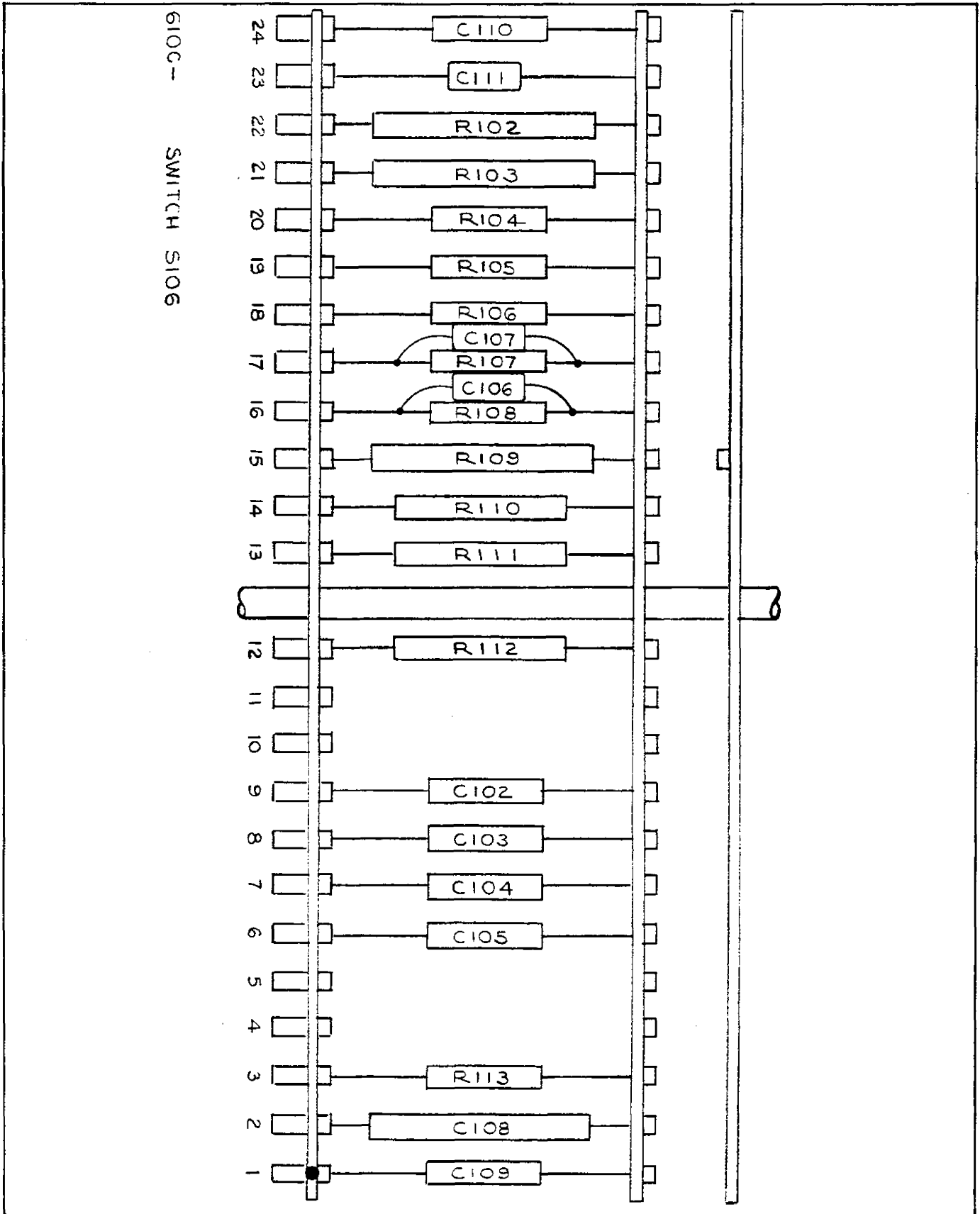

FIGURE 19. Switch, RANGE S106.

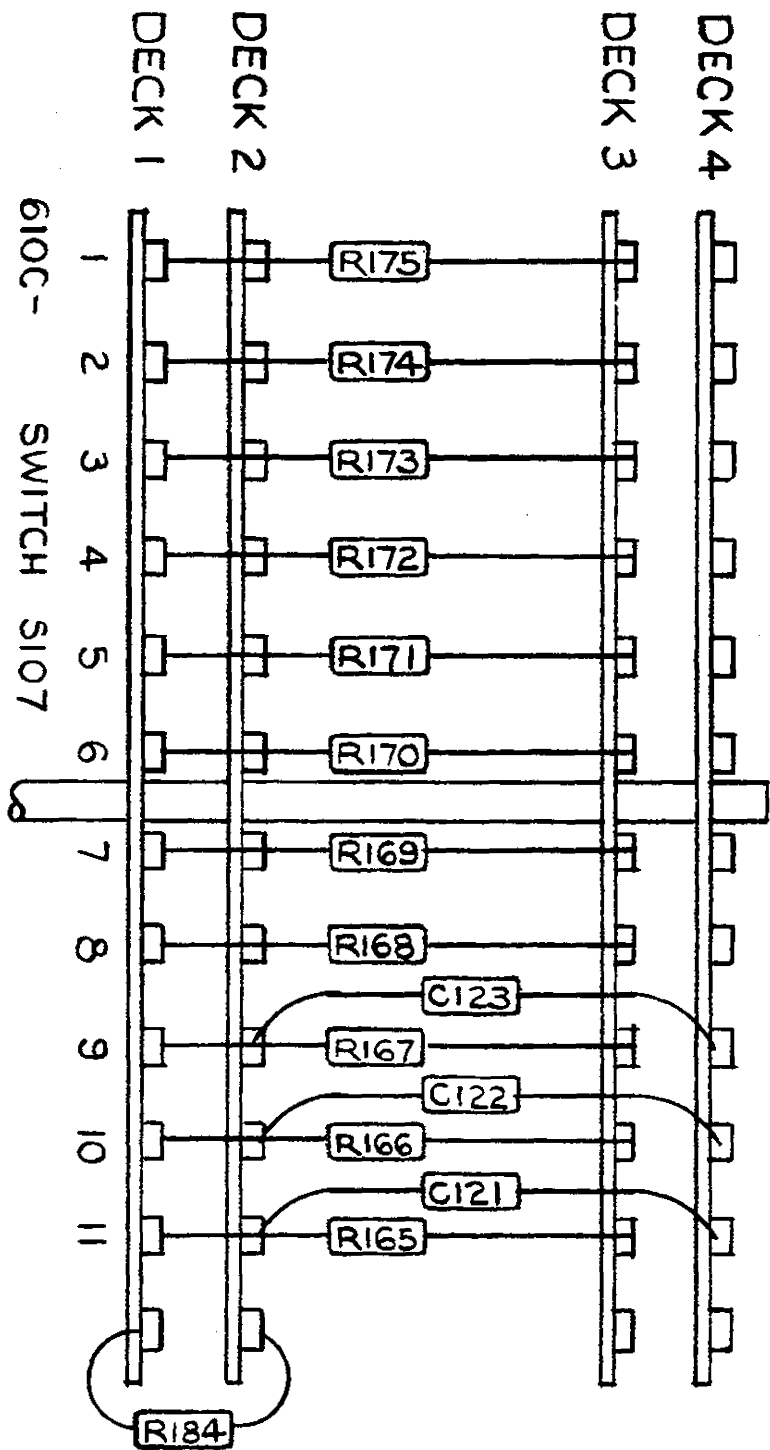

FIGURE 20. Switch, Multiplier, S107.

SECTION 6. CALIBRATION

6-1. GENERAL.

a. The function of the calibration section is to provide a method of checking the Model 610C to make sure that it operates properly and within the specifications given in Table 1 on page ii.

b. The following procedures are recommended for adjusting and calibrating the Model 610C. Use the equipment recommended in Table 6 or their equivalents.

6-2. CALIBRATION SCHEDULE.

a. Check offset current (paragraph 6-8) at regular intervals to make sure the input transistors are functioning correctly.

b. Verify the value of the high-megohm resistors (paragraph 6-10) approximately every six months.

c. Calibrate the ohms ranges (paragraph 6-11) about once a year or when range resistor or power supply components are replaced.

d. Calibrate the meter zero (paragraph 6-4) about once a year or when components are replaced.

e. Check the Model 610C accuracy (paragraph 6-11) once a year, after the other adjustments, or if improper operation is suspected.

NOTE

Unless otherwise stated all the following calibration procedures will be made with the FEEDBACK Switch set to NORMAL and the 3V-LMA Switch set to 3V.

6-3. PRELIMINARY CALIBRATION PROCEDURES.

a. Do not connect the Electrometer to an ac power line. Set the front panel controls as follows:

ZERO CHECK Button	LOCK
RANGE Switch	VOLTS
Multiplier Switch	100
FEEDBACK Switch	NORMAL
METER Switch	POWER OFF

b. Adjust the meter mechanical zero.

c. Plug the Electrometer into a 117 or 234 volt ac line and turn the instrument on. Make sure the unit is zero checked.

1. If the instrument is operative, the meter should be on scale. Decrease the Multiplier Switch setting in steps to the 1 millivolt range and zero the Electrometer on each range with the ZERO Controls.

2. If inoperative, meter pinned, etc., check the power supplies before troubleshooting for other than an obvious problem.

d. Check the power supply voltages as called out in the troubleshooting procedures, paragraph 5-5d.

6-4. MECHANICAL METER SET AND METER ZERO CALIBRATION. Zero whenever other adjustments are made.

a. To set the mechanical Zero meter, turn the METER Switch to METER OFF and set the mechanical Zero Meter adjustment for zero meter reading (top-scale zero).

b. To calibrate meter zero:

1. Turn the Model 610C on. Zero the meter on the .001 Multiplier Switch setting. Then set the Multiplier Switch to 1; apply 1 volt $\pm 0.05\%$ with the Keithley Model 260 Nanovolt Source to the Model 610C INPUT Receptacle. Monitor the output with Keithley Models 160 or 163DVM and a 3:1 adapter. Adjust the FINE ZERO Control for 1.000 volt at the output. Adjust the METER CAL Potentiometer, R179 for full scale meter reading.

2. Set the center zero by first zeroing the meter on the .001 Multiplier Switch setting. Then switch to the 1 position. Set the METER Switch to CENTER ZERO and adjust the Meter Ctr. Cal. potentiometer, R183, for exact center-scale meter zero.

6-5. CALIBRATION OF OHMS RANGES. This calibration adjusts the constant power supply needed for resistance measurements. It must be accurate to maintain specified resistance measurement accuracy.

a. Connect the Model 662 to the junction of resistors R188 and R136 and the common lead to the unity-gain terminal (Figure 2). Adjust the Ohms Cal Potentiometer, R137, for 1 volt dc $\pm 0.5\%$.

b. If the control does not have enough latitude, check the +9 volt supply (paragraph 5-5).

6-6. TRACKING CHECK AND LMA OUTPUT CALIBRATION.

a. Tracking. Set the METER Switch to +, the Multiplier Switch to 1 and apply 1 volt with the Model 260 to the INPUT Receptacle.

1. If the 1 volt range has good accuracy, the meter should indicate full scale. If not, use the .1 or 10 Multiplier Switch settings, whichever has the best full scale accuracy.

2. Check the meter 0-10 scale for no more than 1/2% (1/2 division) tracking error going from zero to full scale in 1/10 of full scale voltage steps.

b. LMA Output. Load output of the Model 610C with a 1400 ohm resistor.

1. Set the 3V-LMA Switch to LMA, the Multiplier Switch to 1 and apply 1 volt to INPUT Receptacle with the Model 260.

2. Adjusting the LMA CAL Control (R177) should vary the output voltage from 1.33 to 1.47 volts, indicating a current variation from 0.95 to 1.05 milliamperes.

3. Depending on the exact value of the 1400 ohm load, the voltage range may be slightly higher or lower than 1.33 to 1.47 volts; for example, 1.34 to 1.48 volts or 1.32 to 1.46 volts. This is satisfactory provided the overall change is at least 140 millivolts and the maximum voltage is near 1.47 volts.

4. Remove the 1400 ohm load and set the 3V-1MA Switch to 3V when completed.

6-7. DC BIAS ADJUST.

a. Zero check unit, zero meter on the .001 volt range and then set to 100 volt range.

b. Connect DCVM across R157 (see PC-183 layout) and adjust DC BIAS pot for 25MV \pm 3MV. DCVM common must be above ground for this measurement.

c. Set range to .001 volts and re-zero. Voltage across R157 should be 25MV \pm 3MV.

6-8. NOISE CHECK.

a. Zero check the unit and connect the output to a Hewlett-Packard Model 3400A RMS Voltmeter.

1. Set the METER Switch to CENTER ZERO and zero the Model 610C on the 1 millivolt range.

2. The Meter noise must be less than 25 microvolts rms or 50 microvolts peak-to-peak.

3. The Output noise must be less than 90 millivolts rms.

b. Switch the Model 610C to the 1 volt range. Output noise must be less than 15 millivolts rms.

c. Excessive output noise may be due to high ripple on the 120 volt or 9 volt supplies. If ripple checks satisfactorily, excessive noise can generally be corrected by reversing the two red leads from the secondary of the transformer.

1. If reversing the red leads does not correct excessive noise, the probable cause is due to high beta for Q111 or Q112. Select for beta range of 35 to 80.

2. Reversing the two yellow leads from the secondary of the transformer may also help reduce excessive noise in some units.

6-8. OFFSET CURRENT CHECK. Check offset current whenever excessive noise or drift is suspected. To read the offset current of the Model 610C, set the front panel controls to:

ZERO CHECK Button	LOCK
Multiplier Switch	.003
Range Switch	10^{-11} AMPERES
FEEDBACK Switch	FAST
METER Switch	+

Cap the INPUT Receptacle and unlock the ZERO CHECK Button. The offset current indicated on the meter should be less than 5×10^{-15} ampere. (This is less than 20% of full scale). If this is exceeded, check the +9 volt supply (paragraph 5-5) and the input transistor, Q101.

6-9. DRIFT CHECK.

a. Set the front panel controls to:

ZERO CHECK Button	LOCK
Multiplier Switch	.03
Range Switch	VOLTS
FEEDBACK Switch	NORMAL
METER Switch	+

Set the 3V-1MA Switch on the back panel to 3V.

b. Connect Model 610C to the Model 370 Recorder. Adjust Recorder sensitivity control completely clockwise (maximum sensitivity) and the 1MA CAL Control of Model 610C for full recorder deflection. Make sure Model 610C chassis cover is attached with at least two screws.

c. Make two drift runs with the Model 610C to determine time and temperature stability individually. For each run allow the Electrometer to warm up for 1/2 hour. A zero drift of less than 2 millivolts after the first half hour is indicative of a satisfactory temperature coefficient. After the first half hour the time stability should be less than 1 millivolt per 24 hours. The offset due to temperature should be less than 150 microvolts per $^{\circ}$ C.

d. If the instrument does not meet the zero drift specification, the input transistors may be faulty.

6-10. HIGH MEGOHM RESISTOR VERIFICATION.

a. About every six months it is necessary to check the value of the high-megohm resistors, R110 to R112, on the Range Switch. The instrument should be within its rated accuracy for two or three years from the time it leaves the factory. After this, some of the resistors may drift out of tolerance and should be replaced. Faulty high-megohm resistors will affect the accuracies of measurements for the 10^{-9} to 10^{-11} AMPERES and the 10^8 to 10^{12} OHMS settings of the Range Switch.

b. To check these resistors, it is necessary to use a bridge capable of better than 1% accuracy up to 10^{11} ohms such as the Keithley Instruments Model 515A Megohm Bridge. If such equipment is not available, two procedures are recommended to check out the resistors:

1. Return the complete instrument to the factory for resistor calibration.
2. Replace the high-megohm resistors periodically with a certified set from Keithley Instruments to assure absolute calibration accuracy.

6-11. ACCURACY CHECK.

a. Checking the accuracy is the quickest way to spot faulty Model 610C operation. Perform the check about once a year, if components are replaced, or if other adjustments are made. If accuracy is verified over all ranges, the Model 610C should be able to meet all specifications. If the accuracy must be checked often, check the stability.

b. Voltage. Connect the Model 610C input to the Model 241 and monitor the output with the Model 160 DVM. First, set the Model 610C for the 10-volt range. Increase the input voltage in 1-volt steps from 0 to 10 volts. The Model 610C should indicate the input voltage to $\pm 1\%$ of full scale. Perform the same operation in the 3-volt range. Connect the Model 610C to the Model 260. Check the other voltage ranges for accuracy of $\pm 1\%$ of full scale. Make sure the 3V-IMA Switch is in the 3V position for the 1, 3 and 10 volt ranges

NOTE

In subparagraph c below, for 10^{-1} ampere through 10^{-5} ampere ranges, a larger Multiplier Switch setting will result in inaccuracies due to loading of the current source; hence the .01 Multiplier Switch setting must be used. The appropriate current source is two decades less than range setting; that is, on the 10^{-1} ampere range use 10^{-3} ampere source, etc.

c. Current. Connect the Model 610C to the Model 261 with the Model 2611 and monitor the output with the Model 160 DVM. Check the full-scale accuracy of all the current positions on the Range Switch. For the 10^{-6} to 10^{-11} ampere ranges, set the FEEDBACK Switch to FAST and the Multiplier Switch to 1. The Model 610C should indicate the input current to $\pm 2\%$ of full scale from 10^{-6} to 10^{-8} ampere ranges and $\pm 4\%$ of full scale from the 10^{-9} to 10^{-11} ampere ranges. For the ranges above 10^{-5} ampere, construct a current source whose output is $\pm 0.25\%$. Set the Model 610C FEEDBACK Switch to NORMAL and the Multiplier Switch to .01 when calibrating these ranges.

d. Ohms. Connect the high side of the Model 5155 Resistor to the center terminal of the INPUT Receptacle and the low side to low. Check the full scale accuracy of all ohm positions on the Range Switch by measuring the voltage drop of the known current across the known sample with the Model 610C. The test current applied is the reciprocal of the OHMS Range Setting. Check the 100 through 10^8 ohm ranges for an accuracy of $\pm 3\%$ of full scale by using the resistance measurement method as described in paragraph 2-5b (FEEDBACK Switch in NORMAL). Check the 10^9 through 10^{12} ohm ranges for an accuracy of $\pm 5\%$ of full scale by employing the resistance measurement method as described in paragraph 2-5c (FEEDBACK Switch in FAST).

e. Coulombs. To check the Model 610C as a charge amplifier, set the FEEDBACK Switch to FAST. Apply 10 volts from the Keithley Model 241 Voltage Supply through a Keithley Model 5155 10^{11} ohm standard to the Model 610C input. Set the Multiplier Switch to the settings given in Table 9. Use a stop watch or a Tektronix Model 561A Oscilloscope to time the rise to full scale deflection. Check each range to $\pm 5\%$.

TABLE 9.

Coulomb Ranges Accuracy Check. The Table gives the Multiplier Switch setting, the coulomb range checked and the rise time for each coulomb range.

Multiplier Switch Setting	Coulombs Range	Rise Time, Zero to Full Scale (seconds)
.01	10^{-7}	10
.1	10^{-8}	10
1	10^{-9}	10
10	10^{-10}	10

6-12. UNITY GAIN CHECK.

a. Zero check the Model 610C and set the instrument to the 100 volt range. Connect the Model 241 Voltage Supply to the Model 610C INPUT Receptacle and to the Model 662 Differential Voltmeter High terminal. Connect the Electrometer X1 OUTPUT Terminal to the Low terminal of the Model 662. Set the Model 662 dial to 0 and the Null Switch to 10 millivolts. The Model 662 should indicate at or near zero.

NOTE

A large transient is generated when the 241 is switched from Standby to Output. To prevent false indication, set 241 to Output and use voltage dial (0 or 10 volts) when making this check.

b. Set the Model 241 to zero volts, release the Electrometer ZERO CHECK Button and note that the Model 662 null remains the same.

1. Apply +100 volts to the Model 610C input with the Voltage Supply. The Differential Voltmeter null indication should not change more than 1 millivolt, indicating a unity gain within 10 ppm.

2. Repeat the test of subparagraph 1 above using -100 volts.

6-13. FREQUENCY RESPONSE CHECK.

a. Zero check the unit. Connect a Wavetek Model 102 Function Generator through a 1000:1 divider to the Model 610C input and connect the Electrometer output to a Hewlett-Packard Model 400 AC VTVM. Set the Electrometer FEEDBACK Switch to NORMAL.

b. Zero the Model 610C on the 10 millivolt range.

1. Set the Signal Generator to 20 Hz at minimum output. Release the Electrometer ZERO CHECK Button and increase the Generator output to obtain 2 volt rms at the Model 610C output.

2. Set the Generator to 100 Hz. The Electrometer output voltage must be within ± 3 dB of the 20 Hz 2 volt rms output.

c. Zero the Model 602 on the 3 volt range and change the divider to 100:1.

1. Set the Generator to 100 Hz and for minimum output. Release the ZERO CHECK Button and increase the Generator output to obtain 0.1 volt rms at the Electrometer output.

2. Set the Generator to 40 kHz. The Model 610C output must be within ± 3 dB of the 100 Hz 0.1 volt rms output.

NOTE

If other than a constant amplitude signal generator (Wavetek) is used, it will be necessary to monitor the output of the signal generator with another VTVM in order to maintain the same signal level at various frequencies specified.

SECTION 7. REPLACEABLE PARTS

7-1. REPLACEABLE PARTS LIST. The Replaceable Parts List describes the components of the Models 610C and 610CR. The List gives the circuit designation, the part description, a suggested manufacturer, the manufacturer's part number and the Keithley Part Number. The last column indicates the figure picturing the part. The name and address of the manufacturers listed in the "Mfg. Code" column are in Table 11.

and serial number, the Keithley Part Number, the circuit designation and a description of the part. All structural parts and those coded for Keithley manufacture (80164) must be ordered through Keithley Instruments, Inc., or its representatives. In ordering a part not listed in the Replaceable Parts List, completely describe the part, its function and its location.

7-2. HOW TO ORDER PARTS.

a. For parts orders, include the instrument's model

b. Order parts through your nearest Keithley representative or the Sales Service Department, Keithley Instruments, Inc.

TABLE 10.
Abbreviations and Symbols.

A	ampere		MfF	Metal Film
CerD	Ceramic, disc		My	Mylar
Comp	Composition		μ	micro (10^{-6})
DCb	Deposited Carbon		No.	number
EA1	Electrolytic, Aluminum		Ω	ohm
ETB	Electrolytic, tubular		p	pico (10^{-12})
F	farad		Poly	Polystyrene
Fig.	Figure		Ref.	Reference
Gcb	Glass enclosed carbon		Req'd.	required
k	kilo (10^3)		V	volt
M or meg	mega (10^6) or megohms		W	watt
Mfg.	Manufacturer		WW	Wirewound
			WWVar	Wirewound Variable

MODELS 610C, 610CR REPLACEABLE PARTS LISTS
(Refer to Schematic Diagram 22821E for circuit designations).

CAPACITORS

Circuit Desig.	Value	Rating	Type	Mfg. Code	Mfg. Part No.	Keithley Part No.	Fig. Ref.
C101	150 pF	600V	CerD	72982	ED-150	C22-150P	19
C102	5 pF	200V	Poly	83125	E1013-1	C31-5P	19
C103	10 pF	500V	Poly	71590	CPR-10J	C138-10P	19
C104	22 pF	500V	Poly	71590	CPR-22J	C138-22P	19
C105	47 pF	500V	Poly	71590	CPR-47J	C138-47P	19
C106	100 pF	160V	Poly	84171	2PJ-101G	C108-100P	19
C107	.001 μ F	160V	Poly	84171	2PJ-102G	C108-.001M	19
C108	.1 μ F	200V	Poly	97419	PYWR-0.1M	C-251-0.1M	19
C109	.01 μ F	160V	Poly	84171	2PJ-103G	C108-.01M	19
C110	.001 μ F	160V	Poly	84171	2PJ-102G	C108-.001M	19
C111	100 pF	160V	Poly	84171	2PJ-101G	C108-100P	19
C112	.001 μ F	600V	CerD	72982	ED-.001	C22-.001M	--
C113	.001 μ F	600V	CerD	72982	ED-.001	C22-.001M	--

CAPACITORS (Cont'd.)

Circuit Desig.	Value	Rating	Type	Mfg. Code	Mfg. Part No.	Keithley Part No.	Fig. Ref.
C114	.033 μ F	200V	MPF	97419	M2WR-.033M	C143-.033M	16
C115	.033 μ F	200V	MPF	97419	M2WR-.033M	C143-.033M	16
C116	150 pF	1000V	CerD	71590	DD-151	C64-150P	16
C117	470 μ F	40V	EAL	73445	ET471X040A2	C150-470M	15
C118	470 μ F	40V	EAL	73445	ET471X040A2	C150-470M	15
C119	40 μ F	350V	ETB	56289	TVA1611	C23-40M	15
C120	40 μ F	350V	ETB	56289	TVA1611	C23-40M	15
C121	.015 μ F	500V	CerD	72982	811-Z5U0-153M	C22-.015M	20
C122	.0047 μ F	500V	CerD	72982	801-Z5U0-472M	C22-.0047M	20
C123	.001 μ F	1000V	CerD	72982	80800Z5R0-102K	C64-.001M	20
C124	100 μ F	15V	ETB	73445	C426	C3-100M	14

DIODES

Circuit Desig.	Description	Mfr. Desig.	Mfr. Code	Keithley Part No.	Fig. Ref.
D101	Silicon	1N645	01295	RF-14	15
D102	Zener, 20V, 1W	1N4747	04713	DZ-25	15
D103	Zener, 9.1V, 0.25W	1N713	12954	DZ-14	15
D104	Zener, 20V, 1W	1N4747	04713	DZ-25	15
D105	Zener	1N713	12954	DZ-14	15
D106	Rectifier, 1A, 800V	1N4006	04713	RF-38	15
D107	Rectifier, 1A, 800V	1N4006	04713	RF-38	15
D108	Zener, 120V, 1W	VR-120A	84970	DZ-32	15
D109	Zener, 120V, 1W	VR-120A	84970	DZ-32	15
D110	Silicon	1N645	01295	RF-14	15
D111	Silicon	1N645	01295	RF-14	15
D112	Silicon	1N645	01295	RF-14	15
D113	Silicon	1N645	01295	RF-14	15
D114	Zener, 9V, 1/2W	1N935	04713	DZ-7	15
D115	Silicon	1N645	01295	RF-14	15

MISCELLANEOUS PARTS

Circuit Desig.	Description	Mfr. Code	Keithley Part No.	Fig. Ref.
21850B	MOS FET Input Plug-in Card (PC-182)	80164	23733A	14
DS101	Pilot Light (Mfg. No. 53)	08804	PL-20	1,3
---	Pilot Light Holder (Mfg. No. 203CE)	81478	PL-18	
F101 (117V)	Fuse, slow blow, 1/4A, 3AG (Mfg. No. 313.250)	75915	FU-17	2,4
F101 (234V)	Fuse, slow blow, 1/8A, 3AG (Mfg. Type MDL)	71400	FU-20	
---	Fuse holder (Mfg. No. 342012)	75915	FH-3	
J101	Receptacle, UHF, INPUT (Mfg. No. 6804)	91737	CS-64	1,3
---	(F)Plug, UHF, Mate of J102 (Mfg. No. 5127)	91737	CS-49	
---	Reducing Adapter, UHF (UG-175/U)	02660	CS-36	
---	Dust cap (Mfg. No. 7901)	91737	CAP-4	
J102	Binding Post (Mfg. No. 33-286)	08811	BP-15	1,3
J103	Receptacle, Microphone, OUTPUT (Mfg. No. 80-PC2F)	02660	CS-32	2,4
---	(F)Plug, Microphone, Mate of J103 (Mfg. No. 80-MC2M)	02660	CS-33	
J104	Binding Post, GUARD (Mfg. No. DF21RC)	58474	BP-11R	2,4
J105	Binding Post, XI OUTPUT (Mfg. No. DF21BC)	58474	BP-11B	2,4
---	Binding Post Adapter (Mfg. No. 29-43)	81073	BP-10	---

(F) Furnished accessory.

MISCELLANEOUS PARTS (Cont'd)

Circuit Desig.	Description	Mfg. Code	Keithley Part No.	Fig. Ref.
J106	Printed Circuit Contacts (Mfg. No. 02-005-113-6-200)	91662	CS-199	--
L101	Choke (Mfg. No. 6302-E)	76493	CH-7	--
L102	Choke (Mfg. No. 6302-E)	76493	CH-7	--
M101	Meter	80164	ME-53	13
P101	Cord Set, 6 feet (Mfg. No. 4638-13) (F) 3 to 2 wire adapter plug	93656 80164	CO-5 CO-4	2, 4 --
P106	Printed Circuit Contacts, Mate of J101 (Mfg. No. 02-005-111-5-200)	91662	CS-200	-- --
S101	Rotary Switch less components, MEDIUM ZERO Rotary Switch with components, Medium Zero Knob, Medium Zero Switch	80164 80164 80164	SW-209 22426B KN-45	1, 3, 13 -- --
S102	Rotary Switch less components, COARSE ZERO Rotary Switch with components, Coarse Zero Knob, Coarse Zero Switch	80164 80164 80164	SW-166 22445B KN-58	2, 3, 13 -- --
S103	Knob, ZERO CHECK Shaft Assembly, Zero Check Button	80164 80164	KN-47 16988A	1, 3, 14 --
S104	Slide Switch, 117-234V	80164	SW-151	2, 4
S105	Slide Switch, FEEDBACK	80164	SW-45	1, 3, 14
S106	Rotary Switch less components, RANGE Rotary Switch with components, Range Knob, Range Switch	80164 80164 80164	SW-257 22425B KN-51	1, 3, 13 -- --
S107	Rotary Switch less components, MULTIPLIER Rotary Switch with components, Multiplier Knob, Multiplier Switch	80164 80164 80164	SW-267 22429B KN-48	1, 3, 13 -- --
S108	Slide Switch, 1MA - 3V	80164	SW-45	2, 4
S109	Rotary Switch less components, METER Knob, Meter Switch 1MA CAL Control Knob, 1MA CAL Control	80164 80164 71450 80164	SW-165 KN-46 RP34-20K KN-58	1, 3, 14 -- 2, 4, 14 --
T101	Transformer Top Cover Assembly (610C) Feet, plastic, 4 required (610C) Handle (610C) Bottom Panel (610C) Bottom Panel (610CR) Top Panel (610CR) Tilt Bail (610C)	80164 80164 80164 80164 80164 80164 80164 80164	TR-70A 17972B FE-5 HH-18 21540C 22284C 22282C 15004B	15 21 21 21 21 -- -- 21

(F) Furnished accessory.

RESISTORS

Circuit Desig.	Value	Rating	Type	Mfg. Code	Mfg. Part No.	Keithley Part No.	Fig. Ref.
R101	10 M Ω	10%, 1/2 W	Comp	01121	EB	R1-10M	
R102	10 Ω	1%, 10 W	WW	91637	RS-10	R34-10	19
R103	100 Ω	1%, 10 W	WW	91637	RS-10	R34-100	19
R104	1 k Ω	1%, 1/2 W	DCb	91637	DCF-1/2	R12-1K	19
R105	10 k Ω	1%, 1/2 W	DCb	07716	DCC	R12-10K	19
R106	100 k Ω	1%, 1/2 W	DCb	91637	DCF-1/2	R12-100K	19
R107	1 M Ω	1%, 1/2 W	DCb	07716	DCC	R12-1M	19
R108	10 M Ω	1%, 1/2 W	DCb	91637	DCF-1/2	R12-10M	19
R109	100 M Ω	1%, 2 W	DCb	91637	DC-2	R14-100M	19
R110	10 ⁹ Ω		Gcb	63060	RX-1	R20-10 ⁹	19
R111	10 ¹⁰ Ω		Gcb	63060	RX-1	R20-10 ¹⁰	19
R112	10 ¹¹ Ω		Gcb	63060	RX-1	R20-10 ¹¹	19
R113	134 k Ω	1%, 1/2 W	DCb	07716	DCC	R12-134K	19
R114	68 k Ω	1%, 1/2 W	DCb	07716	DCC	R12-68K	17
R115	806 Ω	1%, 1/2 W	DCb	91637	DCF-1/2	R12-806	17
R116	806 Ω	1%, 1/2 W	DCb	91637	DCF-1/2	R12-806	17
R117	806 Ω	1%, 1/2 W	DCb	91637	DCF-1/2	R12-806	17
R118	806 Ω	1%, 1/2 W	DCb	91637	DCF-1/2	R12-806	17
R119	806 Ω	1%, 1/2 W	DCb	91637	DCF-1/2	R12-806	17
R120	806 Ω	1%, 1/2 W	DCb	91637	DCF-1/2	R12-806	17
R121	806 Ω	1%, 1/2 W	DCb	91637	DCF-1/2	R12-806	17
R122	806 Ω	1%, 1/2 W	DCb	91637	DCF-1/2	R12-806	17
R123	806 Ω	1%, 1/2 W	DCb	91637	DCF-1/2	R12-806	17
R124	806 Ω	1%, 1/2 W	DCb	91637	DCF-1/2	R12-806	17
R125	68 k Ω	1%, 1/2 W	DCb	07716	DCC	R12-68K	17
R126	249 Ω	1%, 1/2 W	DCb	91637	DCF-1/2-249	R12-249	18
R127	249 Ω	1%, 1/2 W	DCb	91637	DCF-1/2-249	R12-249	18
R128	249 Ω	1%, 1/2 W	DCb	91637	DCF-1/2-249	R12-249	18
R129	249 Ω	1%, 1/2 W	DCb	91637	DCF-1/2-249	R12-249	18
R130	249 Ω	1%, 1/2 W	DCb	91637	DCF-1/2-249	R12-249	18
R131	249 Ω	1%, 1/2 W	DCb	91637	DCF-1/2-249	R12-249	18
R132	249 Ω	1%, 1/2 W	DCb	91637	DCF-1/2-249	R12-249	18
R133	249 Ω	1%, 1/2 W	DCb	91637	DCF-1/2-249	R12-249	18
R134	249 Ω	1%, 1/2 W	DCb	91637	DCF-1/2-249	R12-249	18
R135	249 Ω	1%, 1/2 W	DCb	91637	DCF-1/2-249	R12-249	18
R136	900 Ω	1/2%, 1/2 W	MtF	07716	CEC	R61-900	15
R137	2 k Ω	20%, 2 W	WWVar	71450	1NS 115	RP50-2K	15
R138	6.8 k Ω	1%, 1/2 W	DCb	91637	DCF-1/2	R12-6.8K	15
R139	100 Ω	1/2%, 1/2 W	MtF	07716	CEC	R61-100	15
R140	34.8 k Ω	1%, 1/2 W	MtF	07716	CEC	R94-34.8K	16
R141	200 k Ω	1%, 1/2 W	MtF	07716	CEC	R94-200K	16
R142	10 k Ω	5%, 2 W	WWVar	12697	62JA	RP42-10K	13
R143	40 k Ω	1%, 1/2 W	DCb	07716	DCC	R12-40K	13
R144	200 k Ω	1%, 1/2 W	MtF	07716	CEC	R94-200K	16
R145	2.2 k Ω	10%, 1/2 W	Comp	01121	EB	R1-2.2K	16
R146	36.5 k Ω	1%, 1/2 W	MtF	07716	CEC	R94-36.5K	16
R147	36.5 k Ω	1%, 1/2 W	MtF	07716	CEC	R94-36.5K	16
R148	2.2 k Ω	10%, 1/2 W	Comp	01121	EB	R1-2.2K	16
R149	21.5 k Ω	1%, 1/2 W	MtF	07716	CEC	R94-21.5K	16
R150	7.15 k Ω	1%, 1/2 W	MtF	07716	CEC	R94-7.15K	16
R151	270 k Ω	10%, 1/2 W	Comp	01121	EB	R1-270K	16
R152	4.7 k Ω	10%, 1/2 W	Comp	01121	EB	R1-4.7K	16
R153	100 k Ω	10%, 1/2 W	Comp	01121	EB	R1-100K	16

RESISTORS (Cont'd.)

Circuit Desig.	Value	Rating	Type	Mfg. Code	Mfg. Part No.	Keithley Part No.	Fig. Ref.
R154	15 k Ω	10%, 1/2 W	Comp	01121	EB	R1-15K	15
R155	2 k Ω	20%, 2 W	WWVar	71450	1NS 115	RP50-2K	15
R156	10 Ω	10%, 1/2 W	Comp	01121	EB	R1-10	15
R157	47 Ω	10%, 1/2 W	Comp	01121	EB	R1-47	15
R158	47 Ω	10%, 1/2 W	Comp	01121	EB	R1-47	15
R159	680 Ω	10%, 1/2 W	Comp	01121	EB	R1-680	15
R160	680 Ω	10%, 1/2 W	Comp	01121	EB	R1-680	15
R161	1.8 k Ω	10%, 1/2 W	Comp	01121	EB	R1-1.8K	15
R162	1.8 k Ω	10%, 1/2 W	Comp	01121	EB	R1-1.8K	15
R163	33 k Ω	10%, 2 W	Comp	01121	HB	R3-33K	15
R164	33 k Ω	10%, 2 W	Comp	01121	HB	R3-33K	15
R165	91 k Ω	.1%, 1/2 W	MtF	07716	CEC T-1	R135-91K	20
R166	27.3 k Ω	.1%, 1/2 W	MtF	07716	CEC T-1	R135-27.3K	20
R167	9.1 k Ω	.1%, 1/2 W	MtF	07716	CEC T-1	R135-9.1K	20
R168	2.7 k Ω	.1%, 1/2 W	MtF	07716	CEC T-1	R135-2.7K	20
R169	910 Ω	.1%, 1/2 W	MtF	07716	CEC T-1	R135-910	20
R170	273 Ω	.1%, 1/2 W	MtF	07716	CEC T-1	R135-273	20
R171	91 Ω	.1%, 1/2 W	MtF	07716	CEC T-1	R135-91	20
R172	27.3 Ω	.1%, 1/2 W	MtF	07716	CEC T-1	R135-27.3	20
R173	9.1 Ω	.1%, 1/4 W	WW	01686	7009	R95-9.1	20
R174	2.73 Ω	.1%, 1/4 W	WW	01686	7009	R95-2.73	20
R175	.91 Ω	.1%, 1/4 W	WW	01686	7009	R95-.91	20
R176	8.6 k Ω	1%, 1/2 W	DCb	07716	DCC	R12-8.6K	14
R177	20 k Ω	10%, 5 W	WWVar	71450	AW	RP34-20K	14
R178	2.73 k Ω	.1%, 1/2 W	MtF	07716	CEC T-1	R135-2.73K	14
R179	2 k Ω	20%, 2 W	WWVar	71450	1NS 115	RP50-2K	15
R180	500 Ω	1%, 1/2 W	DCb	07716	DCC	R12-500	15
R181	68 k Ω	10%, 1/2 W	Comp	01121	EB	R1-68K	15
R182	*18 k Ω	1%, 1/2 W	DCb	07716	DCC	R12-18K	15
R183	10 k Ω	20%, 2 W	WWVar	71450	1NS 115	RP50-2K	15
R184	10 Ω	10%, 1/4 W	Comp	44655	RC07	R76-10	20
R185	28.7 k Ω	1%, 1/2 W	MtF	07716	CEC	R94-28.7K	16
R186	36.5 k Ω	1%, 1/2 W	MtF	07716	CEC	R94-36.5K	16
R187	**						
R188	330 Ω	1/2%, 1/2 W	MtF	07716	CEC	R61-330	15
R189	27 k Ω	10%, 1/4 W	Comp	44655	RC07	R76-27K	15

* Nominal value, factory set.

** Part of input plug-in board, replace only by ordering Keithley Part Number 23733A.

TRANSISTORS

Circuit Desig.	Number	Mfg. Code	Keithley Part No.	Fig. Ref.
Q101	**			
Q102	**			
Q103	2N3903	04713	TG-49	16
Q104	2N3903	04713	TG-49	16
Q105	2N3903	04713	TG-49	16
Q106	2N3903	04713	TG-49	16
Q107	2N3903	04713	TG-49	16
Q108	2N3903	04713	TG-49	16
Q109	2N3905	04713	TG-53	16
Q110	2N3905	04713	TG-53	15
Q111	MM3003	04713	TG-58	15
Q112	MM4003	04713	TG-59	15

Chassis Assembly Parts List

Item No.	Description	Qty	Keithley Part No.
1	Top Cover Assembly	1	17972B
-	Top Cover (Sheet Metal)	1	17076B
-	Handle Assembly	1	HH-18
2	Screw, #8-32x1/4", slotted	4	#8-32x1/4 slotted, P.H.
3	Bottom Cover Assembly	1	21540C
-	Bottom Cover (Sheet Metal)	1	21541C
-	Tilt Bail	1	15004B
-	Support Assembly, Right	1	19206B
-	Support Assembly, Left	1	19205B
-	Feet	4	FE-5
-	Rubber Ball	4	FE-6
4	Front Panel	1	16971C
5	Rear Panel	1	21542C

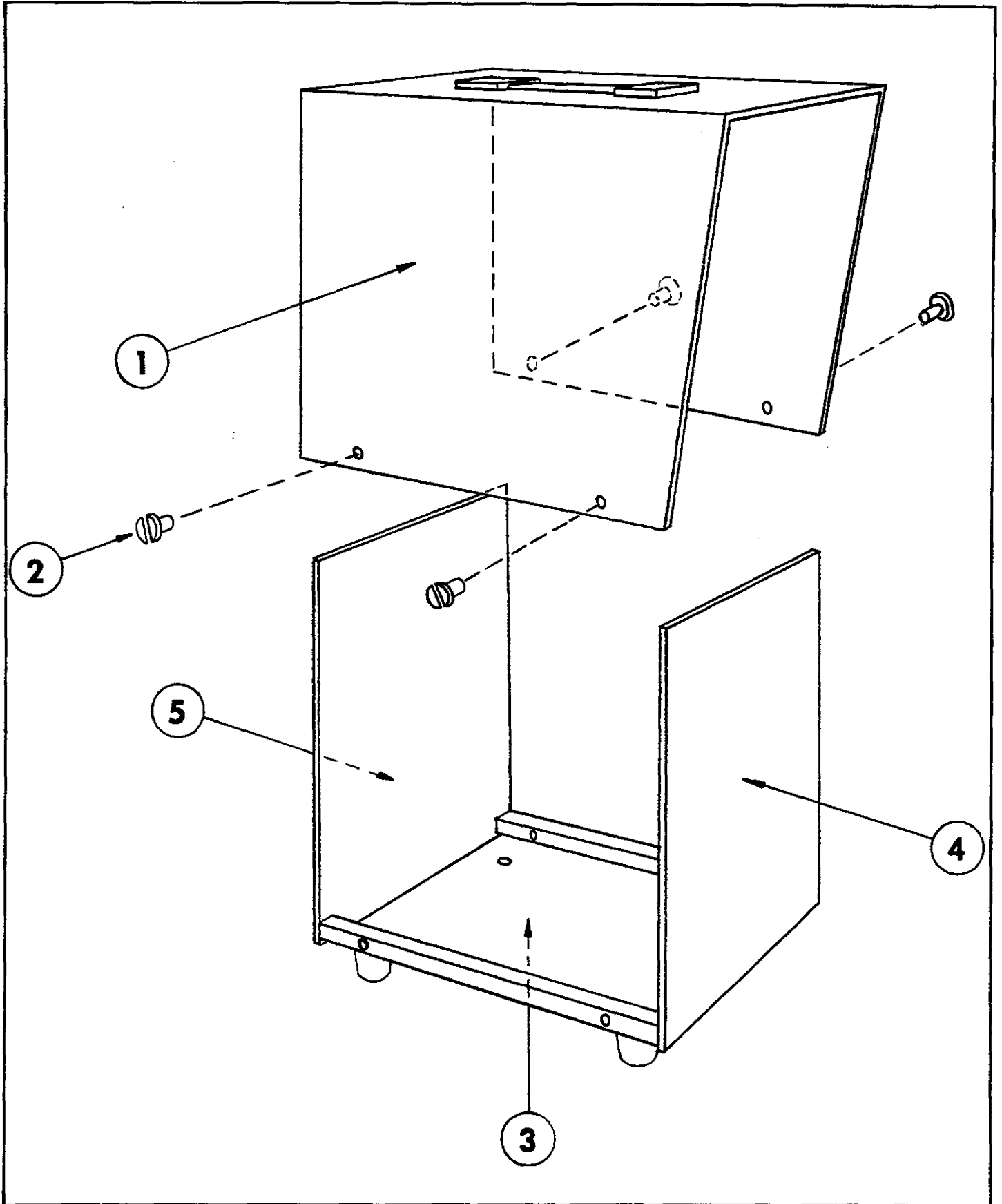
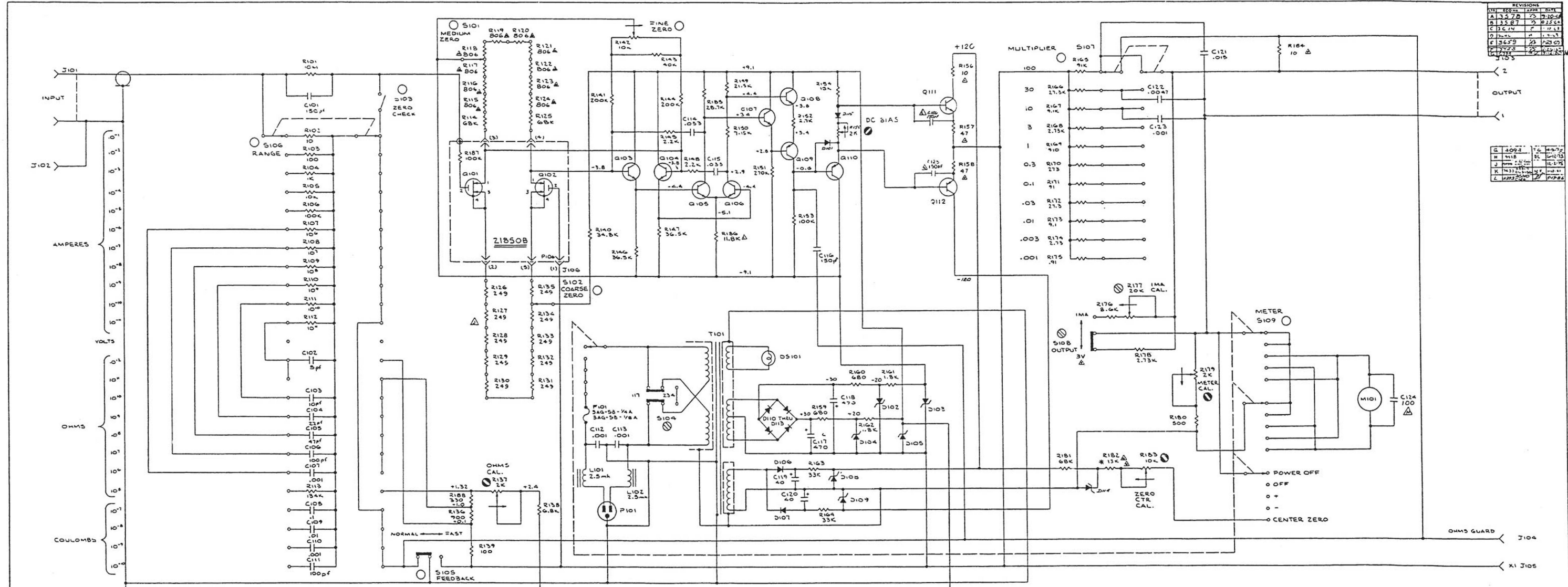

FIGURE 21. Chassis Assembly

TABLE 11.
Code-to-Name List of Manufacturers.

01121	Allen-Bradley Corp. 1201 South 2nd St. Milwaukee, Wis. 53204	12697	Clarostat Mfg. Co., Inc. Lower Washington St. Dover, N.H. 03820	73445	Amperex Electronic Co., Div. of North American Philips Co., Inc. Hicksville, N.Y.
01295	Texas Instruments, Inc. Semiconductor-Components Division 13500 North Central Expwy. Dallas, Texas 75231	12954	Dickson Electronics Corp. 302 S. Wells Fargo Ave. Scottsdale, Arizona	75915	Littlefuse, Inc. 800 E. Northwest Hwy. Des Plaines, Ill. 60016
01686	RCL Electronics, Inc. 195 McGregor Street Manchester, N.H. 03102	13050	Potter Co. Highway 51 N. Wesson, Miss. 39191	76493	Miller, J. W. Co. 5915 S. Main Street Los Angeles, Calif. 90003
02660	Amphenol Corp. 2801 South 25th Ave. Broadview, Illinois 60153	44655	Ohmite Mfg. Co. 3601 Howard St. Skokie, Ill. 60476	80164	Keithley Instruments, Inc. 28775 Aurora Road Cleveland, Ohio 44139
02735	RCA of America Commercial Receiving Tube & Semiconductor Div. Somerville, N.J.	56289	Sprague Electric Co. North Adams, Mass.	81478	Dover Stamping Co. 427 Plymouth Ave. Fall River, Mass.
04713	Motorola Semiconductor Products Division 5005 East McDowell Rd. Phoenix, Arizona 85008	58474	Superior Electric Co., The 383 Middle St. Bristol, Conn. 06012	83125	General Instruments Corp. Capacitor Division Orange Street Darlington, S.C. 29532
07263	Fairchild Camera & Instru- ment Corp. Semiconductor Division 313 Frontage Rd. Mountain View, California	63060	Victoreen Instrument Co. 5806 Hough Avenue Cleveland, Ohio 44103	84171	Allen Electronics Inc. Community Drive Great Neck, N.Y. 11022
07716	IRC Inc. 2850 Mt. Pleasant Burlington, Iowa 52601	71400	Bussmann Mfg. Div. of McGraw-Edison Co. 2531 W. University St. St. Louis, Mo.	84570	Sarkes Tarzian, Inc. E. Hillside Dr. Bloomington, Ind.
08804	General Electric Co. Lamp Metals & Components Department Cleveland Wire Plant 21800 Tungsten Road Cleveland, Ohio 44117	71450	GTS Corp. 1142 W. Beard'sley Ave Elkhart, Ind.	81137	Dale Electronics, Inc. P.O. Box 607 Columbus, Nebr. 68601
08811	GL Electronics Div. of GL Industries, Inc. 300 Harvard Avenue Westville, N.J. 08093	71550	Centralco Div. of Globe- Union, Inc. 932 E. Keefe Avenue Milwaukee, Wis. 53212	91662	Elc Corp. Willow Grove, Pa.
		72982	Erie Technological Products, Inc. 644 W. 12th St. Erie, Pa. 16512	91737	Gremar Mfg. Co., Inc. 7 North Avenue Wakefield, Mass.
				93656	Electric Cord Co. 1275 Bloomfield Avenue Caldwell, N.J.

REV	DATE	BY	REVISION
A	11-27-67	RS	INITIAL
B	12-27-67	RS	REVISION
C	1-27-68	RS	REVISION
D	2-27-68	RS	REVISION
E	3-27-68	RS	REVISION
F	4-27-68	RS	REVISION
G	5-27-68	RS	REVISION
H	6-27-68	RS	REVISION
I	7-27-68	RS	REVISION
J	8-27-68	RS	REVISION
K	9-27-68	RS	REVISION
L	10-27-68	RS	REVISION



- NOTES:
1. ALL RESISTANCE & CAPACITANCE SHALL BE DESIGNATED IN OHMS & MICROFARADS UNLESS OTHERWISE NOTED.
 2. ○ FRONT PANEL CONTROL.
 3. ⊗ INTERNAL SCREWDRIIVER ADJ.
 4. ⊙ REAR PANEL CONTROL.
 5. M MEGOHM
 6. K 1000 OHM
 7. pf PICOFARAD
 8. ↑ CLOCKWISE ROTATION.
 9. ALL VOLTAGES MEASURED REFERRED TO CHASSIS GROUND, WITH S105 IN NORMAL.
 10. * INDICATES NOMINAL VALUE DETERMINED DURING FINAL CAL.

SCHEMATIC DESIGNATIONS NOT USED				SCHEMATIC DESIGNATIONS HIGHEST DESIGNATIONS			
PI02	PI03	PI04	PI05	S109	LI02	DS101	RI08A
				CI26	DI12	DS101	PI06
				T101	DI15	FI01	

DIMENSIONAL TOLERANCES PER MIL-STD-20B UNLESS OTHERWISE SPECIFIED FRACTIONAL DECIMAL INCHES 1/8 3/16 1/4 5/16 3/8 7/16 1/2 5/8 3/4 7/8 1	KEITHLEY INSTRUMENTS CLEVELAND, OHIO	TITLE SCHEMATIC ELECTROMETER PART NUMBER 22821E
---	---	--



Service Form

Model No. _____ Serial No. _____ Date _____

Name and Telephone No. _____

Company _____

List all control settings, describe problem and check boxes that apply to problem. _____

- | | | |
|--|--|--|
| <input type="checkbox"/> Intermittent | <input type="checkbox"/> Analog output follows display | <input type="checkbox"/> Particular range or function bad; specify _____ |
| <input type="checkbox"/> IEEE failure | <input type="checkbox"/> Obvious problem on power-up | <input type="checkbox"/> Batteries and fuses are OK |
| <input type="checkbox"/> Front panel operational | <input type="checkbox"/> All ranges or functions are bad | <input type="checkbox"/> Checked all cables |

Display or output (check one)

- | | |
|-----------------------------------|--|
| <input type="checkbox"/> Drifts | <input type="checkbox"/> Unable to zero |
| <input type="checkbox"/> Unstable | <input type="checkbox"/> Will not read applied input |
| <input type="checkbox"/> Overload | |

- | | |
|---|--|
| <input type="checkbox"/> Calibration only | <input type="checkbox"/> Certificate of calibration required |
| <input type="checkbox"/> Data required | |

(attach any additional sheets as necessary)

Show a block diagram of your measurement system including all instruments connected (whether power is turned on or not). Also, describe signal source.

Where is the measurement being performed? (factory, controlled laboratory, out-of-doors, etc.)

What power line voltage is used? _____ Ambient temperature? _____ °F

Relative humidity? _____ Other? _____

Any additional information. (If special modifications have been made by the user, please describe.)

Be sure to include your name and phone number on this service form.

Specifications are subject to change without notice.

All Keithley trademarks and trade names are the property of Keithley Instruments, Inc. All other trademarks and trade names are the property of their respective companies.



Keithley Instruments, Inc.

BELGIUM: Keithley Instruments B.V.
CHINA: Keithley Instruments China
FRANCE: Keithley Instruments Sarl
GERMANY: Keithley Instruments GmbH
GREAT BRITAIN: Keithley Instruments Ltd.
INDIA: Keithley Instruments GmbH
ITALY: Keithley Instruments s.r.l.
KOREA: Keithley Instruments Korea
NETHERLANDS: Keithley Instruments B.V.
SWITZERLAND: Keithley Instruments SA
TAIWAN: Keithley Instruments Taiwan

28775 Aurora Road • Cleveland, Ohio 44139 • 440-248-0400 • Fax: 440-248-6168
1-888-KEITHLEY (534-8453) www.keithley.com

Bergensesteenweg 709 • B-1600 Sint-Pieters-Leeuw • 02/363 00 40 • Fax: 02/363 00 64
Yuan Chen Xin Building, Room 705 • 12 Yumin Road, Dewai, Madian • Beijing 100029 • 8610-6202-2886 • Fax: 8610-6202-2892
3, allée des Garays • 91127 Palaiseau Cédex • 01 64 53 20 20 • Fax: 01 60 11 77 26
Landsberger Strasse 65 • D-82110 Germering • 089/84 93 07-40 • Fax: 089/84 93 07-34
The Minster • 58 Portman Road • Reading, Berkshire RG30 1EA • 0118-9 57 56 66 • Fax: 0118-9 59 64 69
Flat 2B, WILLOCRISSE • 14, Rest House Crescent • Bangalore 560 001 • 91-80-509-1320/21 • Fax: 91-80-509-1322
Viale San Gimignano, 38 • 20146 Milano • 02-48 39 16 01 • Fax: 02-48 30 22 74
2FL., URI Building • 2-14 Yangjae-Dong • Seocho-Gu, Seoul 137-130 • 82-2-574-7778 • Fax: 82-2-574-7838
Postbus 559 • NL-4200 AN Gorinchem • 0183-635333 • Fax: 0183-630821
Kriesbachstrasse 4 • 8600 Dübendorf • 01-821 94 44 • Fax: 01-820 30 81
1FL., 85 Po Ai Street • Hsinchu, Taiwan, R.O.C. • 886-3-572-9077 • Fax: 886-3-572-9031