

# Model 1753 IEEE Interface

Instruction Manual

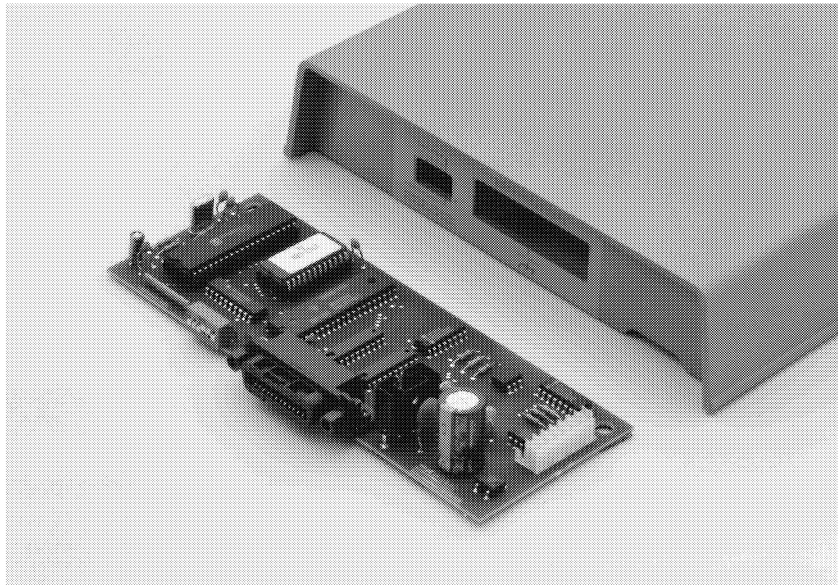

Contains Operating and Servicing Information

**KEITHLEY**

# WARRANTY

Keithley Instruments, Inc. warrants this product to be free from defects in material and workmanship for a period of 1 year from date of shipment.

Keithley Instruments, Inc. warrants the following items for 90 days from the date of shipment: probes, cables, rechargeable batteries, diskettes, and documentation.

During the warranty period, we will, at our option, either repair or replace any product that proves to be defective.

To exercise this warranty, write or call your local Keithley representative, or contact Keithley headquarters in Cleveland, Ohio. You will be given prompt assistance and return instructions. Send the product, transportation prepaid, to the indicated service facility. Repairs will be made and the product returned, transportation prepaid. Repaired or replaced products are warranted for the balance of the original warranty period, or at least 90 days.

## LIMITATION OF WARRANTY

This warranty does not apply to defects resulting from product modification without Keithley's express written consent, or misuse of any product or part. This warranty also does not apply to fuses, software, non-rechargeable batteries, damage from battery leakage, or problems arising from normal wear or failure to follow instructions.

THIS WARRANTY IS IN LIEU OF ALL OTHER WARRANTIES, EXPRESSED OR IMPLIED, INCLUDING ANY IMPLIED WARRANTY OF MERCHANTABILITY OR FITNESS FOR A PARTICULAR USE. THE REMEDIES PROVIDED HEREIN ARE BUYER'S SOLE AND EXCLUSIVE REMEDIES.

NEITHER KEITHLEY INSTRUMENTS, INC. NOR ANY OF ITS EMPLOYEES SHALL BE LIABLE FOR ANY DIRECT, INDIRECT, SPECIAL, INCIDENTAL OR CONSEQUENTIAL DAMAGES ARISING OUT OF THE USE OF ITS INSTRUMENTS AND SOFTWARE EVEN IF KEITHLEY INSTRUMENTS, INC., HAS BEEN ADVISED IN ADVANCE OF THE POSSIBILITY OF SUCH DAMAGES. SUCH EXCLUDED DAMAGES SHALL INCLUDE, BUT ARE NOT LIMITED TO: COSTS OF REMOVAL AND INSTALLATION, LOSSES SUSTAINED AS THE RESULT OF INJURY TO ANY PERSON, OR DAMAGE TO PROPERTY.



Keithley Instruments, Inc. • 28775 Aurora Road • Cleveland, OH 44139 • 440-248-0400 • Fax: 440-248-6168 • <http://www.keithley.com>

|                |                             |   |
|----------------|-----------------------------|---|
| BELGIUM:       | Keithley Instruments B.V.   | Bergensesteenweg 709 • B-1600 Sint-Pieters-Leeuw • 02/363 00 40 • Fax: 02/363 00 64                                   |
| CHINA:         | Keithley Instruments China  | Yuan Chen Xin Building, Room 705 • 12 Yumin Road, Dewai, Madian • Beijing 100029 • 8610-62022886 • Fax: 8610-62022892 |
| FRANCE:        | Keithley Instruments Sarl   | B.P. 60 • 3, allée des Garays • 91122 Palaiseau Cédex • 01 64 53 20 20 • Fax: 01 60 11 77 26                          |
| GERMANY:       | Keithley Instruments GmbH   | Landsberger Strasse 65 • D-82110 Germering • 089/84 93 07-40 • Fax: 089/84 93 07-34                                   |
| GREAT BRITAIN: | Keithley Instruments Ltd    | The Minster • 58 Portman Road • Reading, Berkshire RG30 1EA • 0118-9 57 56 66 • Fax: 0118-9 59 64 69                  |
| INDIA:         | Keithley Instruments GmbH   | Flat 2B, WILOCRISSA • 14, Rest House Crescent • Bangalore 560 001 • 91-80-509-1320/21 • Fax: 91-80-509-1322           |
| ITALY:         | Keithley Instruments s.r.l. | Viale S. Gimignano, 38 • 20146 Milano • 02/48 30 30 08 • Fax: 02/48 30 22 74  |
| NETHERLANDS:   | Keithley Instruments B.V.   | Postbus 559 • 4200 AN Gorinchem • 0183-635333 • Fax: 0183-630821  |
| SWITZERLAND:   | Keithley Instruments SA     | Kriesbachstrasse 4 • 8600 Dübendorf • 01-821 94 44 • Fax: 01-820 30 81  |
| TAIWAN:        | Keithley Instruments Taiwan | 1 Fl. 85 Po Ai Street • Hsinchu, Taiwan, R.O.C. • 886-3572-9077 • Fax: 886-3572-9031                                  |

# Model 1753 IEEE Interface Instruction Manual

The Model 1753 IEEE Interface Instruction Manual covers the following IEEE-488 interface options:

- Model 1753 IEEE-488 Interface (for the Models 175 and 175-AV DMMs)
- Model 1753A IEEE-488 Interface (for the Model 175A DMM)

Throughout the manual, references to the Model 175 also refer to the Models 175A and 175-AV; references to the Model 1753 also refer to the Model 1753A.



# Safety Precautions

---

The following safety precautions should be observed before using this product and any associated instrumentation. Although some instruments and accessories would normally be used with non-hazardous voltages, there are situations where hazardous conditions may be present.

This product is intended for use by qualified personnel who recognize shock hazards and are familiar with the safety precautions required to avoid possible injury. Read the operating information carefully before using the product.

Exercise extreme caution when a shock hazard is present. Lethal voltage may be present on cable connector jacks or test fixtures. The American National Standards Institute (ANSI) states that a shock hazard exists when voltage levels greater than 30V RMS, 42.4V peak, or 60VDC are present. **A good safety practice is to expect that hazardous voltage is present in any unknown circuit before measuring.**

Before operating an instrument, make sure the line cord is connected to a properly grounded power receptacle. Inspect the connecting cables, test leads, and jumpers for possible wear, cracks, or breaks before each use.

For maximum safety, do not touch the product, test cables, or any other instruments while power is applied to the circuit under test. ALWAYS remove power from the entire test system and discharge any capacitors before: connecting or disconnecting cables or jumpers, installing or removing switching cards, or making internal changes, such as installing or removing jumpers.

Do not touch any object that could provide a current path to the common side of the circuit under test or power line (earth) ground. Always make measurements with dry hands while standing on a dry, insulated surface capable of withstanding the voltage being measured.

Do not exceed the maximum signal levels of the instruments and accessories, as defined in the specifications and operating information, and as shown on the instrument or test fixture rear panel, or switching card.

Do not connect switching cards directly to unlimited power circuits. They are intended to be used with impedance limited sources. NEVER connect switching cards directly to AC main. When connecting sources to switching cards, install protective devices to limit fault current and voltage to the card.

When fuses are used in a product, replace with same type and rating for continued protection against fire hazard.

Chassis connections must only be used as shield connections for measuring circuits, NOT as safety earth ground connections.

If you are using a test fixture, keep the lid closed while power is applied to the device under test. Safe operation requires the use of a lid interlock.

If a  screw is present on the test fixture, connect it to safety earth ground using #18 AWG or larger wire.

The  symbol on an instrument or accessory indicates that 1000V or more may be present on the terminals. Refer to the product manual for detailed operating information.

Instrumentation and accessories should not be connected to humans.

Maintenance should be performed by qualified service personnel. Before performing any maintenance, disconnect the line cord and all test cables.

# SPECIFICATIONS

## Accuracy Specifications:

The Model 175 accuracy specifications apply to the instrument if either of the following two conditions are met:

1. Factory Installation—The Model 1753 is installed at the factory and the instrument is operated with the top cover in place.
2. Field Installation—When installed in the field, the instrument must be calibrated and operated with the Model 1753 and top cover installed.

If the Model 175 is operated without recalibration after field installation of the Model 1753 the following deratings apply:

1. For DCV and ohms add two counts to the accuracy specifications.
2. For ACV add 0.5% + 20 counts to the 2V range (50-10kHz).

**Power**—The Model 175 must be operated from line power in order for the Model 1753 to operate.

**Warmup**—1 hour to rated accuracy (top cover installed)

**Maximum Volt-Hertz Product:**  $1 \times 10^6$

## Output:

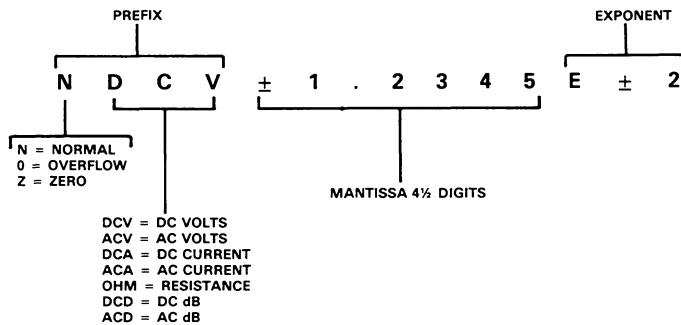

## Trigger to First Byte Out:

- 700msec except 1sec on ohms, typical (T0 and T1 modes).
- 800msec except 2sec on ohms, typical (T3 mode).

## Address Modes:

- Talk Only Mode
- Addressable Mode

## IEEE-488 BUS IMPLEMENTATION

**Multiline Commands:** DCL, SDC, GET, GTL, UNT, UNL, SPE, SPD.

**Uniline Commands:** IFC, REN, EOI, SRQ, ATN.

**Interface Functions:** SH1, AH1, T5, TE0, L4, LE0, SR1, RL2, PP0, DC1, DT1, C0, E1.

**Programmable Parameters:** Range, REL, dB, EOI, Trigger, Calibration, SRQ, Status, Output Format, Terminator.

## DEVICE-DEPENDENT COMMANDS:

**dB:** D0 = dB off  
D1 = dB on

|               |           |               |
|---------------|-----------|---------------|
| <b>Range:</b> | Volts     | Ohms          |
|               | R0 = Auto | Auto          |
|               | R1 = 200m | 200           |
|               | R2 = 2    | 2k            |
|               | R3 = 20   | 20k           |
|               | R4 = 200  | 200k          |
|               | R5 = 2000 | 2M, 20M, 200M |

**Relative:** Z0 = REL off  
Z1 = REL on

**Trigger:** T0 = Continuous on talk  
T1 = One-shot on talk  
T2 = Continuous on GET  
T3 = One-shot on GET  
T4 = Continuous on X  
T5 = One-shot on X

**Execute:** X = Execute other device-dependent commands.

**EOI:** K0 = EOI enabled  
K1 = EOI disable

**Status Word:** U0 = Output status word

**Data Format:** G0 = Readings and status word with 175 prefix  
G1 = Readings and status word without 175 prefix

**SRQ:** M0 = Clear SRQ Data Mask  
M1 = Reading Overflow  
M8 = Reading Done  
M9 = Reading Done or Reading Overflow  
M16 = Busy  
M17 = Busy or Reading Overflow  
M24 = Busy or Reading Done  
M25 = Busy, Reading Done or Reading Overflow  
M32 = Clear SRQ Error Mask  
M33 = IDDC  
M34 = IDDC  
M35 = IDDC or IDDCO  
M36 = Not in Remote  
M37 = Not in Remote or IDDCO  
M38 = Not in Remote or IDDC  
M39 = Not in Remote, IDDC or IDDCO

**Digital Calibration:**  $V \pm n.nnnnE \pm nn$  = n represents calibration value

**Store:** L0 = Store calibration constants

**Terminator:** Y(ASCII) = ASCII character  
Y(LF) = CR LF  
Y(CR) = LF CR  
Y(DEL) = None

# TABLE OF CONTENTS

| Paragraph                                    | Title                                      | Page |
|--|--|------|
| <b>SECTION 1—GENERAL INFORMATION</b>         |  |      |
| 1.1  | Introduction .....                         | 1-1  |
| 1.2  | Model 1753 Features .....                  | 1-1  |
| 1.3  | Warranty Information .....                 | 1-1  |
| 1.4  | Manual Addenda .....                       | 1-1  |
| 1.5  | Safety Symbols and Terms .....             | 1-1  |
| 1.6  | Specifications .....                       | 1-1  |
| 1.7  | Unpacking and Inspection .....             | 1-1  |
| 1.8  | Preparation for Use .....                  | 1-1  |
| <b>SECTION 2—AN OVERVIEW OF THE IEEE-488</b> |  |      |
| 2.1  | Introduction .....                         | 2-1  |
| 2.2  | Bus Description .....                      | 2-1  |
| 2.3  | IEEE-488 Bus Lines .....                   | 2-1  |
| 2.3.1  | Bus Management Lines .....                 | 2-1  |
| 2.3.2  | Handshake Lines .....                      | 2-2  |
| 2.3.3  | Data Lines .....                           | 2-3  |
| 2.4  | Bus Commands .....                         | 2-3  |
| 2.4.1  | Uniline Commands .....                     | 2-3  |
| 2.4.2  | Universal Commands (Multiline) .....       | 2-3  |
| 2.4.3  | Addressed Commands .....                   | 2-4  |
| 2.4.4  | Unaddress Commands .....                   | 2-4  |
| 2.4.5  | Device-Dependent Commands .....            | 2-4  |
| 2.5  | Commands Codes .....                       | 2-4  |
| 2.6  | Command Sequence .....                     | 2-4  |
| 2.6.1  | Addressed Command Sequence .....           | 2-4  |
| 2.6.2  | Universal Command Sequence .....           | 2-6  |
| 2.6.3  | Device-Dependent Command Sequence .....    | 2-6  |
| <b>SECTION 3—OPERATION</b>                   |  |      |
| 3.1  | Introduction .....                         | 3-1  |
| 3.2  | Hardware Considerations .....              | 3-1  |
| 3.2.1  | Typical Controlled Systems .....           | 3-1  |
| 3.2.2  | Bus Connections .....                      | 3-1  |
| 3.2.3  | Addressable Mode Selection .....           | 3-3  |
| 3.2.4  | Primary Address Selection .....            | 3-3  |
| 3.3  | Software Assembly .....                    | 3-4  |
| 3.3.1  | Controller Interface Routines .....        | 3-4  |
| 3.3.2  | HP-85 BASIC Statements .....               | 3-4  |
| 3.3.3  | Interface Function Codes .....             | 3-5  |
| 3.3.4  | Model 175 Interface Commands .....         | 3-5  |
| 3.4  | General Bus Command Programming .....      | 3-6  |
| 3.4.1  | REN (Remote Enable) .....                  | 3-6  |
| 3.4.2  | IFC (Interface Clear) .....                | 3-7  |
| 3.4.3  | GTL (Go To Local) .....                    | 3-7  |
| 3.4.4  | DCL (Device Clear) .....                   | 3-7  |
| 3.4.5  | SDC (Selective Device Clear) .....         | 3-7  |
| 3.4.6  | GET (Group Execute Trigger) .....          | 3-8  |
| 3.4.7  | Serial Polling (SPE, SPD) .....            | 3-8  |
| 3.5  | Device-Dependent Command Programming ..... | 3-8  |
| 3.5.1  | Execute (X) .....                          | 3-10 |
| 3.5.2  | dB (D) .....                               | 3-10 |

# TABLE OF CONTENTS

| Paragraph                                | Title  | Page |
|--|--|------|
| 3.5.3                                    | Range (R) .....  | 3-10 |
| 3.5.4                                    | Relative (Z) .....   | 3-10 |
| 3.5.5                                    | Triggering (T) .....   | 3-10 |
| 3.5.6                                    | EOI (K) .....  | 3-11 |
| 3.5.7                                    | Status Word (U) .....  | 3-11 |
| 3.5.8                                    | SRQ Mode (M) and Status Byte Format .....                          | 3-12 |
| 3.5.9                                    | Data Format .....  | 3-14 |
| 3.5.10                                   | Prefix (G) .....   | 3-14 |
| 3.5.11                                   | Programmable Terminator (Y) .....                                  | 3-15 |
| 3.5.12                                   | Digital Calibration (V) and Storage (L) .....                      | 3-15 |
| 3.6                                      | Talk Only Operation .....  | 3-15 |
| 3.7                                      | Controller Program .....   | 3-16 |
| 3.7.1                                    | Apple II (Apple Interface) .....                                   | 3-16 |
| 3.7.2                                    | HP-85 .....  | 3-16 |
| 3.7.3                                    | HP 9816 .....  | 3-17 |
| 3.7.4                                    | HP 9825A .....   | 3-17 |
| 3.7.5                                    | HP 9826 .....  | 3-17 |
| 3.7.6                                    | IBM Personal Computer XT or PC (National Instrument GPIB-PC) ..... | 3-18 |
| 3.7.7                                    | IBM Personal Computer XT or PC (Tecmar IEEE-488 Interface) .....   | 3-18 |
| 3.7.8                                    | DEC LSI 11 .....   | 3-19 |
| 3.7.9                                    | PET/CBM 2001 .....   | 3-19 |
| 3.7.10                                   | TEK 4052 .....   | 3-20 |
| <br><b>SECTION 4—THEORY OF OPERATION</b> |  |      |
| 4.1                                      | Introduction .....   | 4-1  |
| 4.2                                      | Circuit Description .....  | 4-1  |
| <br><b>SECTION 5—MAINTENANCE</b>         |  |      |
| 5.1                                      | Introduction .....   | 5-1  |
| 5.2                                      | Installation .....   | 5-1  |
| 5.3                                      | Special Handling of Static Sensitive Devices .....                 | 5-1  |
| 5.4                                      | Troubleshooting .....  | 5-1  |
| <br><b>SECTION 6—REPLACEMENT PARTS</b>   |  |      |
| 6.1                                      | Introduction .....   | 6-1  |
| 6.2                                      | Parts List .....   | 6-1  |
| 6.3                                      | Ordering Information .....   | 6-1  |
| 6.4                                      | Factor Service .....   | 6-1  |
| 6.5                                      | Schematic Diagram and Component Location Drawing .....             | 6-1  |

## LIST OF ILLUSTRATIONS

| Figure | Title  | Page |
|--------|--|------|
| 2 - 1  | IEEE-Bus Configuration .....   | 2-2  |
| 2-2    | Handshake Sequence .....   | 2-2  |
| 2-3    | Command Codes .....  | 2-5  |
| 3-1    | System Types .....   | 3-1  |
| 3-2    | IEEE-488 Connector .....   | 3-2  |
| 3-3    | IEEE-488 Connections .....   | 3-2  |
| 3-4    | Contact Assignments .....  | 3-3  |
| 3-5    | Typical IEEE-488 Bus Driver (one of 16) .....                        | 3-3  |
| 3-6    | TO/ADDRESSABLE and Primary Address Switches (Address 24 shown) ..... | 3-3  |
| 3-7    | General Format for U0 Command .....                                  | 3-12 |
| 3-8    | Status Byte Format .....   | 3-14 |
| 3-9    | Data Format .....  | 3-14 |
| 6-1    | Model 1753 Installation .....  | 6-2  |
| 6-2    | Model 1753 Component Location Drawing, Dwg. No. 1753-100 .....       | 6-5  |
| 6-3    | Model 1753 Schematic Diagram, Dwg. No. 1753-106 .....                | 6-7  |

## LIST OF TABLES

| Table | Title   | Page |
|-------|---|------|
| 2-1   | IEEE-488 Bus Command Summary .....              | 2-3  |
| 2-2   | Hexidecimal and Decimal Command Codes .....     | 2-4  |
| 2-3   | Typical Addressed Command Sequence .....        | 2-6  |
| 2-4   | Typical Device-Dependent Command Sequence ..... | 2-6  |
| 3-1   | IEEE Contact Designations .....                 | 3-2  |
| 3-2   | Primary Address Switch Positions .....          | 3-4  |
| 3-3   | HP-85 IEEE-488 BASIC Statements .....           | 3-5  |
| 3-4   | Model 175 Interface Function Codes .....        | 3-6  |
| 3-5   | IEEE Command Groups .....                       | 3-6  |
| 3-6   | General Bus Commands .....                      | 3-6  |
| 3-7   | Default Conditions .....                        | 3-7  |
| 3-8   | Device-Dependent Command Summary .....          | 3-9  |
| 3-9   | SRQ Mask Commands .....                         | 3-13 |
| 3-10  | Status Byte Interpretation .....                | 3-14 |
| 5-1   | Static Sensitive Devices .....                  | 5-1  |
| 5-2   | Model 1753 IEEE-488 Interface Checks .....      | 5-2  |
| 6-1   | Model 1753 Replaceable Parts List .....         | 6-3  |

# SECTION 1 GENERAL INFORMATION

## 1.1 INTRODUCTION

The Model 1753 IEEE-488 interface is designed to enhance the capabilities of the Model 175 DMM by allowing the transmission of data and commands over the IEEE bus. The Model 1753 provides all the digital logic necessary to interface the Model 175 to the bus using the standard IEEE-488-1978 protocol.

## 1.2 MODEL 1753 FEATURES

Some of the important Model 1753 features include:

- Easy Installation. If not already factory installed, the interface may be easily installed in the field.
- IEEE-488-1978 Standard. The Model 1753 communicates with other instruments that use the same IEEE-488-1978 standards.
- Standard IEEE-488 Connector. When the interface is installed in the Model 175, the IEEE-488 connector is available on the rear panel of the instrument.
- Simple Primary Address Selection. The primary address of the Model 1753 may easily be set by using the five address switches on the rear panel of the Model 175.
- Talk Only/Addressable Operation. The interface may be set for one of two modes of operation. In the talk only mode, the Model 175 outputs data to other devices (for example, a printer). In the addressable mode, the Model 175 can both receive commands and transmit data over the bus through the interface.

## 1.3 WARRANTY INFORMATION

Warranty information may be found inside the the front cover of this manual. Should it become necessary to exercise the warranty, contact your nearest Keithley representative or the factory to determine the proper course of action. Keithley Instruments, Inc. maintains service facilities in the United States, United Kingdom, and throughout Europe. Addresses for these facilities may be found outside the rear cover of this manual. Information concerning the application, operation or service of your instrument may be directed to the applications engineer at any of these locations.

## 1.4 MANUAL ADDENDA

Information concerning improvements or changes to the interface which occur after the printing of this manual may be found on an Addendum sheet attached to the inside back cover of this manual. Be sure to review these changes before attempting to use the interface.

## 1.5 SAFETY SYMBOLS AND TERMS

The following safety symbols and terms are used in this manual and found on the Model 175.

The symbol  on the instrument indicates that the user should refer to the operating instructions.

The symbol  on the instrument indicates that a potential of 1000V or more may be present on the terminal(s). Standard safety precautions should be observed when such dangerous voltages are encountered.

Information associated with the **WARNING** heading explains dangers that could result in personal injury or death.

Information following the **CAUTION** heading explains hazards that could damage the instrument.

## 1.6 SPECIFICATIONS

Model 1753 specifications may be found immediately preceding this section of the manual.

## 1.7 UNPACKING AND INSPECTION

The Model 1753 interface was carefully inspected both mechanically and electrically before shipment. Upon receiving the Model 1753, carefully unpack all items and check for any obvious physical damage that might have occurred during shipment. Report any damage to the shipping agent immediately. Retain the original packing materials in case reshipment is necessary. The following items are shipped with every Model 1753 order:

- Model 1753 IEEE-488 Interface
- Hardware necessary for installation.
- Modified Top Cover
- Model 1753 Instruction Manual
- Additional accessories as ordered.

## 1.8 PREPARATION FOR USE

As shipped, the Model 1753 interface is set to the addressable mode with the primary address set to 24 at the factory. For information on changing these parameters, refer to Section 3. If the Model 1753 is to be field installed, refer to Section 5 for necessary installation instructions.



## SECTION 2 AN OVERVIEW OF THE IEEE-488 BUS

### 2.1 INTRODUCTION

The IEEE-488 bus is an instrumentation data bus standardized by the Institute of Electronic and Electrical Engineers in 1975. The most recent revision of bus standards was made in 1978; hence the complete description for current bus standards is the IEEE-488-1978 designation.

This section gives a brief description of the general bus structure along with an outline of bus commands. The information presented here is not intended to be an in-depth description of what is a very complex standard. More complete information on the IEEE-488 bus, which is also frequently referred to as the GPIB (General Purpose Interface Bus), is available from the IEEE and a variety of other sources.

### 2.2 BUS DESCRIPTION

The IEEE-488 bus was designed as a parallel data transfer medium to optimize data transfer without using an excessive number of bus lines. In keeping with this goal, the bus has only eight data lines that are used for both data and some commands. Five bus management lines and three handshake lines round out the complement of signal lines. Since the bus is of parallel design, all devices connected to the bus have the same information available simultaneously. Exactly what is done with the information by each device depends on many factors, including device capabilities.

A typical bus configuration for controlled operation is shown in Figure 2-1. The typical system will have one controller and one or more instruments to which commands are given and, in most cases, from which data is received. Generally, there are three categories that describe device operation. These designations include: controller; talker; listener.

The controller does what its name implies: it controls other devices on the bus. A talker sends data, while a listener receives data. Depending on the instrument, a particular device may be a talker only, a listener only, or both a talker and a listener. The Model 175, through the 1753 interface, is capable of being both a talker and a listener, but it does not have controller capability.

Any given system can have only one controller (control may be passed to an appropriate device through a special command), but any number of talkers or listeners may be present up to the hardware constraints of the bus. Generally, the bus is limited to 15 devices, but this number may be reduced if higher than normal data transfer rates are required or if longer than normal cables are used.

Several devices may be commanded to listen at once, but only one device may be a talker at any given time. Otherwise, communications would be scrambled much like an individual trying to pick out a single conversation in a large crowd.

Before a device can talk or listen, it must be appropriately addressed. Devices are selected on the basis of their primary address. To avoid confusion, the addressed device is sent a talk or listen command derived from its primary address. Normally, each device on the bus has a unique primary address so that each may be addressed individually. The primary address of the Model 1753 interface is set to 24 at the factory, but it may be changed to any value between 0 and 30 as described in Section 3.

Once the device is addressed to talk or listen, the appropriate bus transactions will take place. For example, if the Model 1753 is properly addressed to talk, it will normally place its data string on the bus one byte at a time. The controller will then read this information, and the appropriate software can then be used to channel the information to the desired location. Other bus functions and instrumentation may be controlled by special bus commands as described in paragraph 2.3.

### 2.3 IEEE-488 BUS LINES

The signal lines on the IEEE-488 bus are grouped into three general categories. The data lines handle bus information, while the handshake and bus management lines ensure that proper data transfer and bus operation takes place. Each of the bus lines is inverted so that low is true. The following paragraphs describe the purpose of these lines, which are shown in Figure 2-1.

#### 2.3.1 Bus Management Lines

The bus management group is made up of five signal lines that send certain single-line bus commands and ensure an orderly transfer of data. These lines are used to send the single-line commands described in paragraph 2.4.

1. ATN (Attention)-The attention line is one of the more important management lines. The state of the ATN line determines whether information on the data bus is to be considered data or a command as described in paragraph 2.4.
2. IFC (Interface Clear)-Setting the IFC line true (low) causes the bus to go to a known state by sending the IFC command.
3. REN (Remote Enable)-Setting the REN line low sends the REN command. This sets up instruments on the bus for remote operation.

4. EOI (End Or Identify)-The EOI line is used to terminate a multi-byte transfer sequence.
5. SRQ (Service Request)-The SRQ line is set low by a bus device when it requires service from the controller.

2. NRFD (Not Ready For Data)-The acceptor controls the state of the NRFD line.
3. NDAC (Not Data Accepted)-The acceptor also controls the NDAC line.

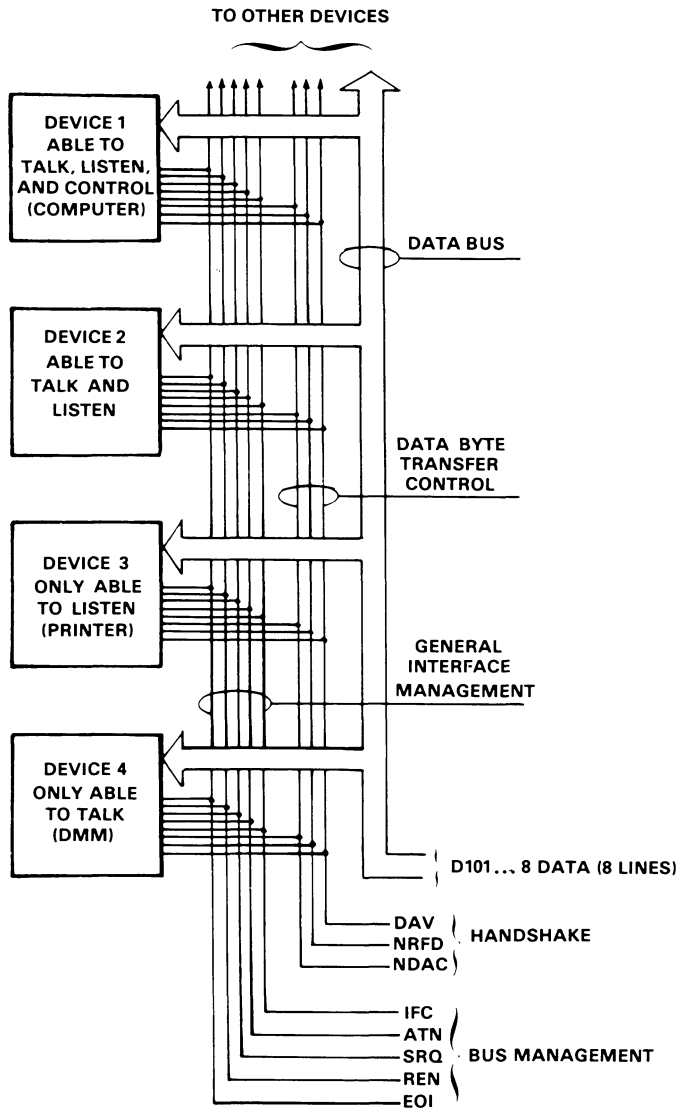

Figure 2-1. IEEE Bus Configuration

### 2.3.2 Handshake Lines

The bus uses three handshake lines that operate in an interlocked sequence. This method ensures reliable data transfer regardless of the transfer rate. Generally, data transfer will occur at a rate determined by the slowest active device on the bus.

One of the handshake lines is controlled by the data source, while the remaining two lines are controlled by accepting devices. The three bus handshake lines are:

1. DAV (Data Valid)-The source controls the state of the DAV line.

The complete handshake sequence for one data byte is shown in Figure 2-2. Once data is on the bus, the source checks to see that NRFD is high, indicating that all devices on the bus are ready for data. At the same time NDAC should be low from the previous byte transfer. If these conditions are not met, the source must then wait until the NRFD and NDAC lines have the correct status. Because of the possibility of a bus hang up, some controllers have time-out routines to display error messages if the handshake sequence stops for any reason.

Once the NRFD and NDAC lines are properly set, the source sets the DAV line low, indicating that data on the bus is now valid. The NRFD line then goes low; the NDAC line then goes high once all devices on the bus have accepted the data. Each device will release the NDAC line at its own rate, but the NDAC line will not go high until the slowest device has accepted the data.

After the NDAC line goes high, the source then sets the DAV line high to indicate that the data on the bus is no longer valid. At this point, the NDAC line returns to its low state. Finally, the NRFD line is released by each of the devices at their own rates, until the NRFD line finally goes high when the slowest device is ready, and the bus is set to repeat the sequence with the next byte of data.

The sequence just described is used to transfer both data and multiline commands. The state of the ATN lines determines whether the data bus contains data or commands as described in paragraph 2.4.

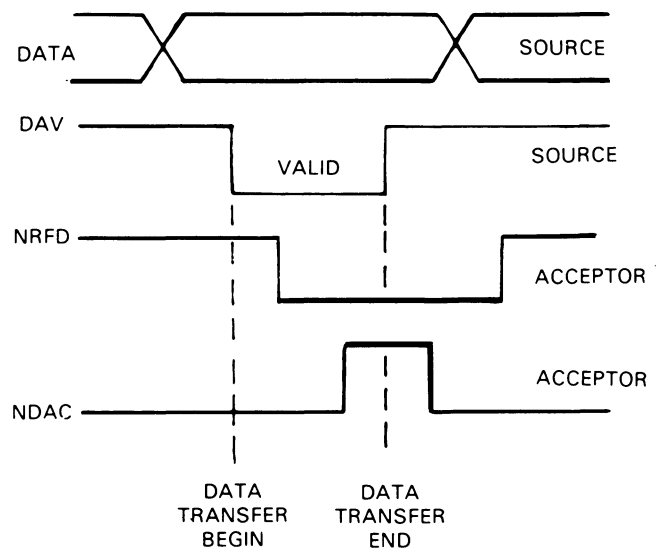

Figure 2-2. Handshake Sequence

### 2.3.3 Data Lines

The IEEE-488 bus uses eight data lines that allow data to be transmitted and received in a bit-parallel, byte-serial manner. These eight lines use the convention DIO1 through DIO8 instead on the usual D0 through D7 binary terminology. The data lines are bidirectional and, as with the remaining bus signal lines, low is true.

### 2.4 BUS COMMANDS

While the hardware aspect of the bus is important, the interface would be worthless without appropriate commands to control communications between the various instrument on the bus. This section will briefly describe the purpose of the bus commands which are grouped into the following three general categories:

1. Uniline commands: Sent by setting the associated bus line low.
2. Multiline commands: General bus commands which are sent with the ATN line low.
3. Device-Dependent commands: Special commands that depend on device configurations; sent with ATN high.

These commands are summarized in Table 2-1. Only commands that affect Model 175 operation are covered in this section.

#### 2.4.1 Uniline Commands

Uniline commands are sent by setting the associated bus line low. The ATN, IFC, and REN commands are sent only by the system controller. The SRQ command is asserted by an external device. The EOI command may be sent by either the controller or an external device. The following is a brief description of each command:

1. REN (Remote Enable)-When the controller sends the REN command, the instrument will be set up for remote operation. This command should be sent to the instrument before attempting to program over the bus.
2. EOI-The EOI command is transmitted by setting the EOI (End Or Identify) line low during the last byte of a multi-byte transfer sequence.
3. IFC (Interface Clear)-The IFC command is sent by setting the IFC line low; it sets the bus to a known state.
4. ATN (Attention)-The controller sets ATN low when sending multiline commands. Device-dependent commands are sent with ATN high. The ATN line must remain high while a device transmits its data string.
5. SRQ (Service Request)-The SRQ line is set low by an external device when it requires service from the controller. A serial polling sequence, as described in paragraph 3.4.7, must be used to determine which device has requested service.

#### 2.4.2 Universal Commands (Multiline)

Universal commands are multiline commands that require no addressing. All instrumentation equipped to implement the command will do so when the command is transmitted over the bus. As with all multiline commands, the universal commands are sent with ATN low.

1. DCL (Device Clear)-After a DCL is sent, instrumentation equipped to implement the command will revert to some known state.
2. SPE (Serial Poll Enable)-The SPE command is the first step in the serial polling sequence, which is used to determine which instrument has requested service.
3. SPD (Serial Poll Disable)-The SPD command is sent by the controller to remove all instrumentation on the bus from the serial poll mode. The Model 175 will no longer place its status byte on the bus when addressed to talk after the SPD command is sent.

**Table 2-1. IEEE-488 Bus Command Summary**

| Command Type       | Command               | State of ATN Line*           | Comments                              |                                       |
|--------------------|-----------------------|------------------------------|---------------------------------------|---------------------------------------|
| Uniline            | REN (Remote Enable)   | X                            | Set up for remote operation.          |                                       |
|                    | EOI (End or Identify) | X                            | Sent by setting EOI low.              |                                       |
|                    | IFC (Interface Clear) | X                            | Clears Interface                      |                                       |
|                    | ATN (Attention)       | Low                          | Defines data bus contents.            |                                       |
|                    | SRQ (Service Request) | X                            | Controlled by external device.        |                                       |
| Multiline          | Universal             | DCL (Device Clear)           | Low                                   | Returns device to default conditions. |
|                    |                       | SPE (Serial Poll Enable)     | Low                                   | Enables serial polling.               |
|                    |                       | SPD (Serial Poll Disable)    | Low                                   | Disables serial polling.              |
|                    | Addressed             | SDC (Selective Device Clear) | Low                                   | Returns unit to default conditions.   |
|                    |                       | GTL (Go to Local)            | Low                                   | Returns to local control.             |
|                    | Unaddress             | GET (Group Execute Trigger)  | Low                                   | Triggers device for reading.          |
| UNL (Unlisten)     |                       | Low                          | Removes all listeners from bus.       |                                       |
|                    | UNT (Untalk)          | Low                          | Removes all talkers from bus.         |                                       |
| Device-dependent** |                       | High                         | Programs Model 175 for various modes. |                                       |

\*X = Don't Care

\*\*See Section 3 for complete description.

### 2.4.3 Addressed Commands

Each of these commands must be preceded by a listen command derived from the device's primary address before the instrument will respond. Only the addressed device will respond to each of these commands:

1. SDC (Selective Device Clear)-The SDC command performs essentially the same function as the DCL command except that only the addressed device will respond.
2. GTL (Go To Local)-The GTL command is used to remove instruments from the remote mode of operation.
3. GET (Group Execute Trigger)-The GET command is used to trigger devices to perform some action that depends on device configuration.

### 2.4.4 Unaddress Commands

The two unaddress commands are used by the controller to remove all talkers and listeners from the bus simultaneously. No addressing is required to implement these commands.

1. UNL (Unlisten)-All listeners are removed from the bus at once when the UNL command is placed on the bus.
2. UNT (Untalk)-The controller sends the UNT command to clear the bus of any talkers.

### 2.4.5 Device-Dependent Commands

The meaning of the device-dependent commands is determined by instrument configuration. Generally, these commands are sent as one or more ASCII characters that tell the device to perform a specific function. For complete information on using these commands with the Model 175, refer to Section 3. The IEEE-488 bus treats device-dependent commands as data in that the ATN line is high when the commands are transmitted.

## 2.5 COMMAND CODES

Each bus command is given a unique code that is transmitted over the bus as 7 bit ASCII data. This section will briefly explain the code groups which are summarized in Figure 2-3. Every command is sent with ATN low.

1. Addressed Command Group (ACG)-Addressed commands are listed in column 0(B) in the table. Column 0(A) lists the corresponding ASCII codes.
2. Universal Command Group (UCG)-Columns 1(A) and 1(B) list the Universal commands and the corresponding ASCII codes.
3. Listen Address Group (LAG)-Columns 2(A) and 3(A) list the ASCII codes corresponding to the primary addresses listed in columns 2(B) and 3(B). The primary address value set by the switches on the rear panel of the Model 175 corresponds to the listed value. For example, if the primary address of the instrument is set to eight, the LAG byte will correspond to the ASCII "(" character.
4. Talk Address Group (TAG)-TAG primary address values and the corresponding ASCII characters are listed in columns 4(A) through 5(B).

The preceding address groups are all grouped together to form the Primary Command Group (PCG). The bus also has another group of commands, called the Secondary Command Group (SCG). These are listed in Figure 2-3 for informational purposes only; the Model 1753 does not respond to these commands, but other devices may have secondary addressing capability.

#### NOTE

Commands are normally transmitted with the 7 bit code listed in the table. For most devices, the condition of  $D_7$  (DI08) is unimportant, as shown by the "Don't Care" indication in the table. Some devices, however, may require that  $D_7$  assumes a specific logic state before the commands are recognized.

Hexadecimal and decimal values for each of the commands or command groups are listed in Table 2-2. Each value in the table assumes that  $D_7$  is set to 0.

Table 2-2. Hexadecimal and Decimal Command Codes

| Command | Hex Value* | Decimal Value |
|---------|------------|---------------|
| GTL     | 01         | 1             |
| SDC     | 04         | 4             |
| GET     | 08         | 8             |
| DCL     | 14         | 20            |
| SPE     | 18         | 24            |
| SPD     | 19         | 25            |
| LAG     | 20-3F      | 32-63         |
| TAG     | 40-5F      | 64-95         |
| UNL     | 3F         | 63            |
| UNT     | 5F         | 95            |

\*Values shown with  $D_7 = 0$ .

## 2.6 COMMAND SEQUENCE

The proper command sequence must be sent by the controller before an instrument will respond as intended. The universal commands, such as DCL require only that ATN be set low before the command is sent. Other commands require that the device be addressed to listen first. This section will briefly describe the bus sequence for several types of commands.

### 2.6.1 Addressed Command Sequence

Before a device will respond to one of these commands, it must receive a LAG command derived from its primary address. Table 2-3 shows a typical sequence for the SDC command. The LAG command assumes that the instrument is set at a primary address of 24.

Note that an UNL command is transmitted before the LAG, SDC sequence. This is generally done to remove all other listeners from the bus first so that only the addressed device responds.

| D7 D6 D5 D4 Bits |   | D3 | D2 | D1 | D0  | COLUMN - | 0 (A) | 0 (B) | 1 (A) | 1 (B) | X 0 0 0 | X 0 1 0 | 2 (A) | 2 (B) | 3 (A) | 3 (B) | 4 (A) | 4 (B) | 5 (A) | 5 (B) | 6 (A) | 6 (B) | 7 (A) | 7 (B) |
|------------------|---|----|----|----|-----|----------|-------|-------|-------|-------|---------|---------|-------|-------|-------|-------|-------|-------|-------|-------|-------|-------|-------|-------|
| 1                | 1 | 1  | 1  | 1  | 1   | ROW1     | 0 (A) | 0 (B) | 1 (A) | 1 (B) | X 0 0 0 | X 0 1 0 | 2 (A) | 2 (B) | 3 (A) | 3 (B) | 4 (A) | 4 (B) | 5 (A) | 5 (B) | 6 (A) | 6 (B) | 7 (A) | 7 (B) |
| 0                | 0 | 0  | 0  | 0  | 0   | NUL      | 0 (A) | 0 (B) | 1 (A) | 1 (B) | X 0 0 0 | X 0 1 0 | 2 (A) | 2 (B) | 3 (A) | 3 (B) | 4 (A) | 4 (B) | 5 (A) | 5 (B) | 6 (A) | 6 (B) | 7 (A) | 7 (B) |
| 0                | 0 | 0  | 1  | 1  | 1   | SOH      | 0 (A) | 0 (B) | 1 (A) | 1 (B) | X 0 0 0 | X 0 1 0 | 2 (A) | 2 (B) | 3 (A) | 3 (B) | 4 (A) | 4 (B) | 5 (A) | 5 (B) | 6 (A) | 6 (B) | 7 (A) | 7 (B) |
| 0                | 0 | 1  | 0  | 0  | 2   | STX      | 0 (A) | 0 (B) | 1 (A) | 1 (B) | X 0 0 0 | X 0 1 0 | 2 (A) | 2 (B) | 3 (A) | 3 (B) | 4 (A) | 4 (B) | 5 (A) | 5 (B) | 6 (A) | 6 (B) | 7 (A) | 7 (B) |
| 0                | 0 | 1  | 1  | 1  | 3   | ETX      | 0 (A) | 0 (B) | 1 (A) | 1 (B) | X 0 0 0 | X 0 1 0 | 2 (A) | 2 (B) | 3 (A) | 3 (B) | 4 (A) | 4 (B) | 5 (A) | 5 (B) | 6 (A) | 6 (B) | 7 (A) | 7 (B) |
| 0                | 1 | 0  | 0  | 4  | EOT | SDC      | 0 (A) | 0 (B) | 1 (A) | 1 (B) | X 0 0 0 | X 0 1 0 | 2 (A) | 2 (B) | 3 (A) | 3 (B) | 4 (A) | 4 (B) | 5 (A) | 5 (B) | 6 (A) | 6 (B) | 7 (A) | 7 (B) |
| 0                | 1 | 0  | 0  | 5  | ENQ | PPC*     | 0 (A) | 0 (B) | 1 (A) | 1 (B) | X 0 0 0 | X 0 1 0 | 2 (A) | 2 (B) | 3 (A) | 3 (B) | 4 (A) | 4 (B) | 5 (A) | 5 (B) | 6 (A) | 6 (B) | 7 (A) | 7 (B) |
| 0                | 1 | 1  | 0  | 6  | ACK |          | 0 (A) | 0 (B) | 1 (A) | 1 (B) | X 0 0 0 | X 0 1 0 | 2 (A) | 2 (B) | 3 (A) | 3 (B) | 4 (A) | 4 (B) | 5 (A) | 5 (B) | 6 (A) | 6 (B) | 7 (A) | 7 (B) |
| 0                | 1 | 1  | 1  | 7  | BEL |          | 0 (A) | 0 (B) | 1 (A) | 1 (B) | X 0 0 0 | X 0 1 0 | 2 (A) | 2 (B) | 3 (A) | 3 (B) | 4 (A) | 4 (B) | 5 (A) | 5 (B) | 6 (A) | 6 (B) | 7 (A) | 7 (B) |
| 1                | 0 | 0  | 0  | 8  | BS  | GET      | 0 (A) | 0 (B) | 1 (A) | 1 (B) | X 0 0 0 | X 0 1 0 | 2 (A) | 2 (B) | 3 (A) | 3 (B) | 4 (A) | 4 (B) | 5 (A) | 5 (B) | 6 (A) | 6 (B) | 7 (A) | 7 (B) |
| 1                | 0 | 0  | 1  | 9  | HT  | TCT*     | 0 (A) | 0 (B) | 1 (A) | 1 (B) | X 0 0 0 | X 0 1 0 | 2 (A) | 2 (B) | 3 (A) | 3 (B) | 4 (A) | 4 (B) | 5 (A) | 5 (B) | 6 (A) | 6 (B) | 7 (A) | 7 (B) |
| 1                | 0 | 1  | 0  | 10 | LF  |          | 0 (A) | 0 (B) | 1 (A) | 1 (B) | X 0 0 0 | X 0 1 0 | 2 (A) | 2 (B) | 3 (A) | 3 (B) | 4 (A) | 4 (B) | 5 (A) | 5 (B) | 6 (A) | 6 (B) | 7 (A) | 7 (B) |
| 1                | 0 | 1  | 1  | 11 | VT  |          | 0 (A) | 0 (B) | 1 (A) | 1 (B) | X 0 0 0 | X 0 1 0 | 2 (A) | 2 (B) | 3 (A) | 3 (B) | 4 (A) | 4 (B) | 5 (A) | 5 (B) | 6 (A) | 6 (B) | 7 (A) | 7 (B) |
| 1                | 1 | 0  | 0  | 12 | FF  |          | 0 (A) | 0 (B) | 1 (A) | 1 (B) | X 0 0 0 | X 0 1 0 | 2 (A) | 2 (B) | 3 (A) | 3 (B) | 4 (A) | 4 (B) | 5 (A) | 5 (B) | 6 (A) | 6 (B) | 7 (A) | 7 (B) |
| 1                | 1 | 0  | 1  | 13 | CR  |          | 0 (A) | 0 (B) | 1 (A) | 1 (B) | X 0 0 0 | X 0 1 0 | 2 (A) | 2 (B) | 3 (A) | 3 (B) | 4 (A) | 4 (B) | 5 (A) | 5 (B) | 6 (A) | 6 (B) | 7 (A) | 7 (B) |
| 1                | 1 | 1  | 0  | 14 | SO  |          | 0 (A) | 0 (B) | 1 (A) | 1 (B) | X 0 0 0 | X 0 1 0 | 2 (A) | 2 (B) | 3 (A) | 3 (B) | 4 (A) | 4 (B) | 5 (A) | 5 (B) | 6 (A) | 6 (B) | 7 (A) | 7 (B) |
| 1                | 1 | 1  | 1  | 15 | SI  |          | 0 (A) | 0 (B) | 1 (A) | 1 (B) | X 0 0 0 | X 0 1 0 | 2 (A) | 2 (B) | 3 (A) | 3 (B) | 4 (A) | 4 (B) | 5 (A) | 5 (B) | 6 (A) | 6 (B) | 7 (A) | 7 (B) |

\*PPC (Parallel Poll Configure), PPU (Parallel Poll Unconfigure), and TCT (Take Control) not implemented by Model 2243

NOTE: D<sub>0</sub> = DIO1...D<sub>7</sub> = DIO8  
X = Don't Care

Figure 2-3. Command Codes

### 2.6.2 Universal Command Sequence

The universal commands are sent by setting ATN low and then placing the command on the bus. For example, the following is placed on the bus to give the DCL command:

ATN•DCL

Note that both the ATN and DCL commands are on the bus simultaneously. Also, addressing is not necessary.

### 2.6.3 Device-Dependent Command Sequence

The device-dependent commands are transmitted with ATN high. However, the device must be addressed to listen first before the commands are transmitted. Table 2-4 shows the command sequence for the following:

D1X

This command, which sets the Model 175 to the dB function, is described in detail in Section 3.

**Table 2-3. Typical Addressed Command Sequence**

| Step | Command | ATN State    | Data Bus |     |         |
|------|---------|--------------|----------|-----|---------|
|      |         |              | ASCII    | Hex | Decimal |
| 1    | UNL     | Set low      | ?        | 3F  | 63      |
| 2    | LAG*    | Stays low    | 8        | 38  | 56      |
| 3    | SDC     | Stays low    | EOT      | 04  | 4       |
| 4    |         | Returns high |          |     |         |

\*Assumes primary address = 24.

**Table 2-4. Typical Device-Dependent Command Sequence**

| Step | Command | ATN State  | Data Bus |     |         |
|------|---------|------------|----------|-----|---------|
|      |         |            | ASCII    | Hex | Decimal |
| 1    | UNL     | Set low    | ?        | 3F  | 63      |
| 2    | LAG*    | Stays low  | 8        | 38  | 56      |
| 3    | Data    | Set high   | F        | 46  | 70      |
| 4    | Data    | Stays high | 0        | 30  | 48      |
| 5    | Data    | Stays high | X        | 58  | 88      |

\*Assumes primary address = 24.

## SECTION 3 OPERATION

### 3.1 INTRODUCTION

The Model 1753 is designed to interface the Model 175 to the IEEE-488 bus. The volts and ohms ranges, and the dB and REL features are controlled by programming commands over the IEEE-488 bus.

This section deals with important hardware and software aspects of bus operation and describes important programming functions in detail. Included are: general bus commands, device-dependent commands, status word and status byte, and other important operating information.

### 3.2 HARDWARE CONSIDERATIONS

Before the Model 175 can be used with the IEEE-488 bus, the instrument must be connected to the bus using a suitable connector. Also, the instrument must be set up for Addressable operation and the primary address must be properly selected as described in this section.

**NOTE**

Allow the Model 175/1753 to warm up (power on) for one hour before using.

#### 3.2.1 Typical Controlled Systems

The IEEE-488 bus is a parallel system. As a result, adding more devices is simply a matter of using more cables to make the desired connections. Because of this flexibility, system complexity can range from the very simple to extremely complex.

Figure 3-1 shows two typical system configurations. Figure 3-1(a) shows the simplest possible controlled system. The controller is used to send commands to the instrument, which sends data back to the controller.

The system becomes more complex in Figure 3-1(b), where additional instrumentation is added. Depending on programming, all data may be routed through the controller, or it may be transmitted directly from one instrument to another.

For very complex applications, a much larger computer can be used. Tape drives or disks can then be used to store data.

#### 3.2.2 Bus Connections

The Model 175 is connected to the bus through an IEEE-488 connector which is shown in Figure 3-2. This connector is designed to be stacked to allow a number of parallel connections on one instrument.

**NOTE**

To avoid possible mechanical damage, it is recommended that no more than three connectors be stacked on any one instrument. Otherwise, the resulting strain may cause internal damage.

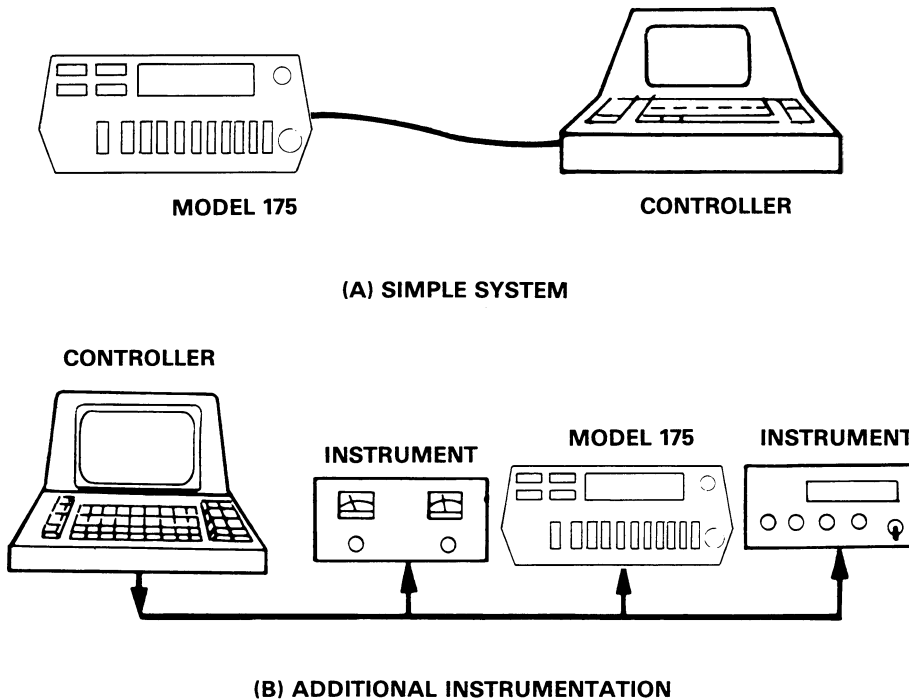

**Figure 3-1. System Types**

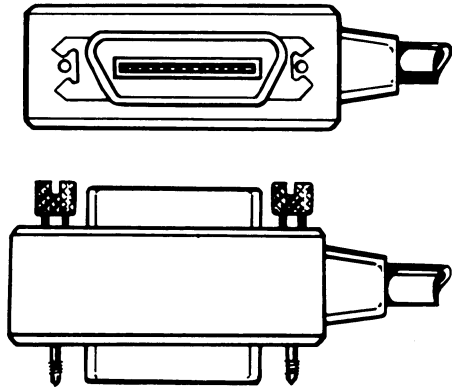

**Figure 3-2. IEEE-488 Connector**

A typical connecting scheme for the bus is shown in Figure 3-3. Each cable normally has the standard IEEE connector on each end. The Keithley Model 7008-3 or 7008-6 cable is ideal for this purpose. Once the connections are made, the screws should be tightened securely. The connector is located on the rear panel of the Model 175.

**NOTE**

The IEEE-488 bus is limited to a maximum of 15 devices, including the controller. Also, the maximum cable length is 20 meters. Failure to observe these limits will probably result in erratic bus operation.

Custom cables may be constructed using the information in Table 3-1 and Figure 3-4. Table 3-1 lists the contact assignments for the various bus lines, while Figure 3-4 shows contact designations. Contact 18 through 24 are return lines for the indicated signal lines, and the cable shield is connected to contact 12. Each ground line is connected to digital common in the Model 175.

**Table 3-1. IEEE Contact Designations**

| Contact Number | IEEE-488 Designation | Type       |
|----------------|----------------------|------------|
| 1              | DIO1                 | Data       |
| 2              | DIO2                 | Data       |
| 3              | DIO3                 | Data       |
| 4              | DIO4                 | Data       |
| 5              | EOI (24)*            | Management |
| 6              | DAV                  | Handshake  |
| 7              | NRFD                 | Handshake  |
| 8              | NDAC                 | Handshake  |
| 9              | IFC                  | Management |
| 10             | SRQ                  | Management |
| 11             | ATN                  | Management |
| 12             | SHIELD               | Ground     |
| 13             | DIO5                 | Data       |
| 14             | DIO6                 | Data       |
| 15             | DIO7                 | Data       |
| 16             | DIO8                 | Data       |
| 17             | REN (24)*            | Management |
| 18             | Gnd, (6)*            | Ground     |
| 19             | Gnd, (7)*            | Ground     |
| 20             | Gnd, (8)*            | Ground     |
| 21             | Gnd, (9)*            | Ground     |
| 22             | Gnd, (10)*           | Ground     |
| 23             | Gnd, (11)*           | Ground     |
| 24             | Gnd, LOGIC           | Ground     |

\*Numbers in parentheses refer to signal ground return of reference contact number. EOI and REN signal lines return on contact 24.

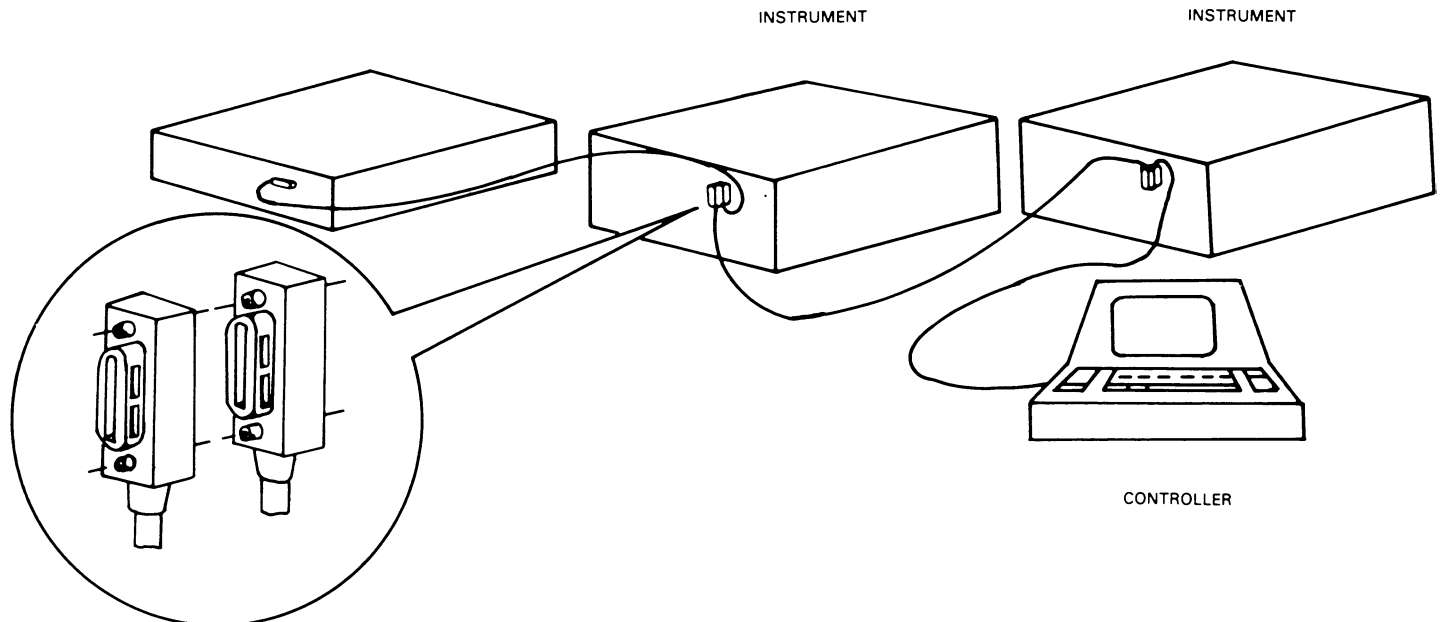

**Figure 3-3. IEEE-488 Connections**

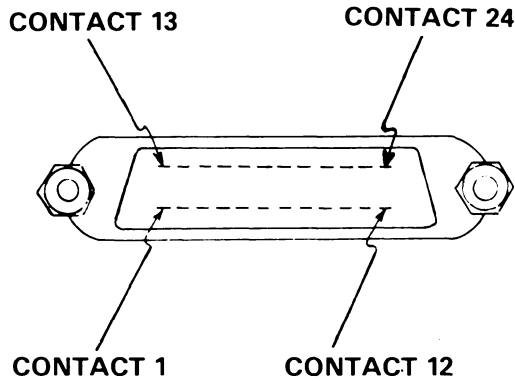

Figure 3-4. Contact Assignments

**CAUTION**

The voltage between IEEE common and ground must not exceed 30V or damage to the instrument may occur.

A typical signal line bus driver is shown in Figure 3-5. With the configuration shown, the driver has bidirectional capability. When the I/O control line is high, the line is configured as an output line. When the control line is low, the driver is set up for input operation. Note that not all signal lines have bidirectional capability. Some lines, such as ATN, will always be configured as an output line in the controller and as an input line for all other devices on the bus.

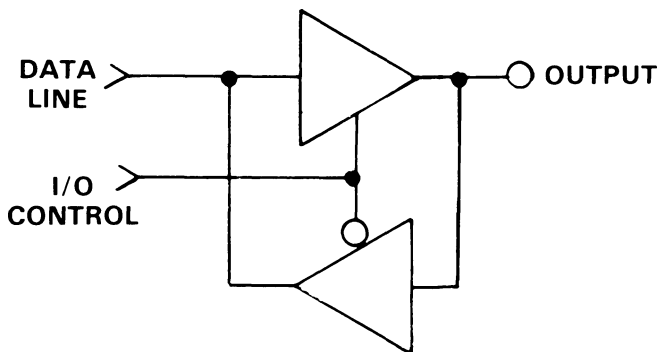

Figure 3-5. Typical IEEE-488 Bus Driver (One of 16)

**3.2.3 Addressable Mode Selection**

The Model 1753 must be set to the addressable mode when used with an external controller. Mode selection is done with the TO/ADDRESSABLE mode selection switch located on the rear panel of the Model 175. This switch is grouped with those that set the primary address; these switches are located on the rear panel of the Model 175. Figure 3-6 shows the ADDRESSABLE position for the switch.

The TO/ADDRESSABLE switch is read only upon power-up. If the mode is changed, the Model 175 must be turned off and then powered-up again before it will recognize the new switch position.

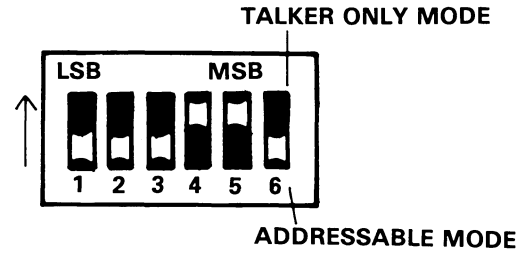

Figure 3-6. TO/ADDRESSABLE and Primary Address Switches (Factory Set Address 24 Shown)

**3.2.4 Primary Address Selection**

The Model 175 must receive a listen command before it will respond to the addressed or device-dependent commands sent over the bus. Similarly, a talk command must be sent to the Model 175 before it will transmit its data string, status word, or status byte. Those talk and listen commands are derived from the primary address of the instrument. The primary address of the Model 1753 is set to 24 at the factory, but it may be set to any value between 0 and 30 by placing the primary address switches which are shown in Figure 3-6, in the desired position. The primary address specified in the controller's programming language must agree with the primary address of the Model 1753.

**NOTE**

The primary address switch positions are read only upon power-up. If the address is changed, the Model 175 must be turned off and then powered-up again before the new address can be used.

Figure 3-6 shows the correct positions for the factory set value of 24, if a different address is required, the primary address may be changed as outlined in Table 3-2.

**NOTE**

If other instrumentation is also connected to the bus, be sure that each device has a different primary address. If this precaution is not observed, erratic bus operation may result.

The primary address switches are binary weighted; A1 is the least significant bit, while A5 the most significant bit. For example, the binary value for the factory set primary address of eight is 01000. Use the tip of a pen or pencil to operate the switches.

**NOTE**

No instrument on the bus (including the Model 175) should be operated with a primary address of 31, even though it is possible to set the switches to those positions (11111). This address is reserved for the UNL and UNT commands; instruments will respond by removing themselves from the talk or listen modes if primary address 31 is used.

**Table 3-2. Primary Address Switch Positions**

| Primary Address | 5 | 4 | 3 | 2 | 1 |
|-----------------|---|---|---|---|---|
| 0               | 0 | 0 | 0 | 0 | 0 |
| 1               | 0 | 0 | 0 | 0 | 1 |
| 2               | 0 | 0 | 0 | 1 | 0 |
| 3               | 0 | 0 | 0 | 1 | 1 |
| 4               | 0 | 0 | 1 | 0 | 0 |
| 5               | 0 | 0 | 1 | 0 | 1 |
| 6               | 0 | 0 | 1 | 1 | 0 |
| 7               | 0 | 0 | 1 | 1 | 1 |
| 8               | 0 | 1 | 0 | 0 | 0 |
| 9               | 0 | 1 | 0 | 0 | 1 |
| 10              | 0 | 1 | 0 | 1 | 0 |
| 11              | 0 | 1 | 0 | 1 | 1 |
| 12              | 0 | 1 | 1 | 0 | 0 |
| 13              | 0 | 1 | 1 | 0 | 1 |
| 14              | 0 | 1 | 1 | 1 | 0 |
| 15              | 0 | 1 | 1 | 1 | 1 |
| 16              | 1 | 0 | 0 | 0 | 0 |
| 17              | 1 | 0 | 0 | 0 | 1 |
| 18              | 1 | 0 | 0 | 1 | 0 |
| 19              | 1 | 0 | 0 | 1 | 1 |
| 20              | 1 | 0 | 1 | 0 | 0 |
| 21              | 1 | 0 | 1 | 0 | 1 |
| 22              | 1 | 0 | 1 | 1 | 0 |
| 23              | 1 | 0 | 1 | 1 | 1 |
| 24              | 1 | 1 | 0 | 0 | 0 |
| 25              | 1 | 1 | 0 | 0 | 1 |
| 26              | 1 | 1 | 0 | 1 | 0 |
| 27              | 1 | 1 | 0 | 1 | 1 |
| 28              | 1 | 1 | 1 | 0 | 0 |
| 29              | 1 | 1 | 1 | 0 | 1 |
| 30              | 1 | 1 | 1 | 1 | 0 |

### 3.3 SOFTWARE ASSEMBLY

The most sophisticated computer in the world would be useless without the necessary software. This basic requirement is also true of the IEEE-488 bus, which requires the use of handler routines as described in this section.

#### 3.3.1 Controller Interface Routines

Before a controller can be used with the IEEE-488 interface, the user must make certain that appropriate handler software is present within the controller. With the HP-85 computer, for example, the HP-IB interface card must be used with an additional I/O ROM, which contains the necessary handler software.

Other small computers that can be used as controllers have limited IEEE command capability. The PET/CBM computers, for example, are incapable of sending the universal and addressed multiline commands from BASIC, although most of these commands may be sent through machine-language routines. The capabilities of other small computers depends

on the particular interface being used. Often, little software "tricks" are required to achieve the desired results.

From the preceding discussion, the message is clear: make sure the proper software is being used with the interface. Often, the user may incorrectly suspect that a hardware problem is causing an intermittent fault, when it was the software that was causing the problem all along.

#### 3.3.2 HP-85 BASIC Statements

Many of the programming instructions use examples written in Hewlett-Packard Model 85 BASIC. The HP-85 was chosen for these examples because it has a large number of BASIC statements that control IEEE-488 operation. This section covers those HP-85 BASIC statements that are essential to Model 1753 operation.

A complete list of HP-85 IEEE-488 BASIC statement is shown in Table 3-3. All the statements in the table have a one or three digit argument that must be specified. The first digit is the HP-85 interface select code, which is set to 7 at the factory. The last two digits of those statements that require a three digit argument specify the primary address. Generally, only those commands that actually require an address to be sent over the bus need the primary address to be specified.

The statements in the table with the three digit arguments assume that the primary address of the device (in this case the Model 1753) is set at 24. Other primary addresses require that the last two digits be set to the corresponding value. For example, to send a GTL command to device 21, the following BASIC statement would be used: LOCAL 721.

Some of the statements in the table have two forms; the exact configuration used depends on the desired command. For example, CLEAR 7 will cause a DCL to be sent, while CLEAR 724 causes an SDC to be transmitted to device 24.

The third column of Table 3-3 lists the mnemonics for the command sequences. While most of these have been covered before, a couple of points should be noted. As described earlier, the ATN line is set low by the controller if the data bus contains a multiline command. This is indicated in the table by ANDing the ATN mnemonic with the first command on the bus. For example, ATN.GET means that ATN and GET are sent simultaneously.

Two commands not previously covered are MLA (My Listen Address) and MTA (My Talk Address). These are ordinary PCG (Primary Command Group) addresses sent by the HP-85 to facilitate bus operation in some situations. The Model 1753 will normally ignore these commands, but other devices may require that MLA and MTA be present in the command sequence under certain circumstances.

**NOTE**

The HP-85 address is set to 21 at the factory. Since each device on the bus must have a unique primary address, do not set the Model 175 to that address to avoid conflicts with the HP-85.

**3.3.3 Interface Function Codes**

The interface function codes are part of the IEEE-488-1978 standards. These codes define an instrument's ability to support various interface functions and should not be confused with programming commands found elsewhere in this manual.

Table 3-4 lists the codes for the Model 1753. These codes are also listed for convenience on the rear panel of the instrument immediately above the IEEE connector. The numeric value following each one or two letter code defines Model 175 capabilities as follows:

1. SH1(Source Handshake Function)-The ability for the Model 175 to initiate the transfer of message/data on the data bus is provided by the SH function.
2. AH1(Acceptor Handshake Function)-The ability for the Model 175 to guarantee proper reception of message/data on the data bus is provided by the AH function.
3. T5(Talker Function)-The ability for the Model 175 to send device-dependent data over the bus (to other devices) is provided by the T function. Model 175 talker capabilities exist only after the instrument has been addressed to talk.

4. L4(Listener Function)-The ability for the Model 175 to receive device-dependent data over the bus (from other devices) is provided by the L function. Listener function capabilities of the Model 175 exist only after it has been addressed to listen.
5. SR1(Service Request Function)-The ability for the Model 175 to request service from the controller is provided by the SR function.
6. RL2(Remote-Local Function)-The ability for the Model 175 to be placed in the remote or local modes is provided by the RL function.
7. PP0(Parallel Poll Function)-The Model 175 does not have parallel polling capabilities.
8. DC1(Device Clear Function)-The ability for the Model 175 to be cleared (initialized) is provided by the DC function.
9. DT1(Device Trigger Function)-The ability for the Model 175 to have its readings triggered is provided by the DT function.
10. C0(Controller Function)-The Model 175 does not have controller capabilities.
11. TE0(Extended Talker Capabilities)-The Model 175 does not have extended talker capabilities.
12. LE0(Extended Listener Capabilities)-The Model 175 does not have extended listener capabilities.

**3.3.4 Model 175 Interface Commands**

Interface commands controlling Model 175 operation are listed in Table 3-5. Not included in the table are device-dependent commands, which are covered in detail in paragraph 3.5.

**Table 3-3. HP-85 IEEE-488 BASIC Statements**

| Statement  | Action  | Bus Command Sequence   |
|--|---|--|
| ABORTIO 7<br>CLEAR 7<br>CLEAR 724<br>ENTER 724;A\$ | Send IFC.<br>Send DCL.<br>Send SDC to device 24.<br>Device 24 addressed to talk.<br>Data placed in A\$. | IFC<br>ATN•DCL<br>ATN•UNL;MTA;LAG;SDC<br>ATN•UNL;MLA;TAG;ATN;data  |
| LOCAL 724<br>OUTPUT 724;A\$                        | Send GTL to device 24.<br>Device 24 addressed to listen.<br>Transmit A\$.                               | ATN•UNL;MTA;LAG;GTL<br>ATN•MTA;UNL;LAG;ATN;data                    |
| REMOTE 7<br>REMOTE 724                             | Set REN true.<br>Send REN true. Address device 24 to listen.  | REN<br>REN;ATN•UNL;MTA;LAG   |
| RESET 7<br>SPOLL(724)                              | Send IFC, cancel REN.<br>Address device 24 to talk.<br>Conduct serial poll.                             | IFC;REN;REN<br>ATN•UNL;MLA;TAG;SPE;ATN;<br>status byte;ATN•SPD;UNT |
| TRIGGER 7<br>TRIGGER 724                           | Send GET<br>Address device 24 to listen.<br>Send GET.   | ATN•GET<br>ATN•UNL;MTA;LAG;GET                                     |

**Table 3-4. Model 175 Interface Function Codes**

| Code | Interface Function   |
|------|--|
| SH1  | Source Handshake Capability  |
| AH1  | Acceptor Handshake Capability  |
| T5   | Talker (Basic Talker, Serial Poll, Talk Only Mode, Unaddressed To Talk On LAG) |
| L4   | Listener (Basic Listener, Unaddressed To Listen On TAG)                        |
| SR1  | Service Request Capability   |
| RL2  | No Local Lockout Capability  |
| PP0  | No Parallel Poll Capability  |
| DC1  | Device Clear Capability  |
| DT1  | Device Trigger Capability  |
| C0   | No Controller Capability   |
| E1   | Open Collector Bus Drivers   |
| TE0  | No Extended Talker Capabilities  |
| LE0  | No Extended Listener Capabilities  |

**Table 3-5. IEEE Command Groups**

|                                |                               |
|--------------------------------|-------------------------------|
| <b>HANDSHAKE COMMAND GROUP</b> |                               |
|                                | DAC = DATA ACCEPTED           |
|                                | RFD = READY FOR DATA          |
|                                | DAV = DATA VALID              |
| <b>UNIVERSAL COMMAND GROUP</b> |                               |
|                                | ATN = ATTENTION               |
|                                | DCL = DEVICE CLEAR            |
|                                | IFC = INTERFACE CLEAR         |
|                                | LLO = LOCAL LOCKOUT           |
|                                | REN = REMOTE ENABLE           |
|                                | SPD = SERIAL POLL DISABLE     |
|                                | SPE = SERIAL POLL ENABLE      |
| <b>ADDRESS COMMAND GROUP</b>   |                               |
| LISTEN:                        | LAG = LISTEN ADDRESS GROUP    |
|                                | MLA = MY LISTEN ADDRESS       |
|                                | UNL = UNLISTEN                |
| TALK:                          | TAG = TALK ADDRESS GROUP      |
|                                | MTA = MY TALK ADDRESS         |
|                                | UNT = UNTALK                  |
|                                | OTA = OTHER TALK ADDRESS      |
| <b>ADDRESSED COMMAND GROUP</b> |                               |
|                                | ACG = ADDRESSED COMMAND GROUP |
|                                | GET = GROUP EXECUTE TRIGGER   |
|                                | GTL = GO TO LOCAL             |
|                                | SDC = SELECTIVE DEVICE CLEAR  |
| <b>STATUS COMMAND GROUP</b>    |                               |
|                                | RQS = REQUEST SERVICE         |
|                                | SRQ = SERIAL POLL REQUEST     |
|                                | STB = STATUS BYTE             |
|                                | END = EOI                     |

**3.4 GENERAL BUS COMMAND PROGRAMMING**

General bus commands are those commands which have the same general meaning regardless of instrument configuration. These commands are grouped into two categories:

1. Addressed Commands. These commands require that the primary address of the instrument agrees with the primary address in the controller's programming language.
2. Unaddressed Commands. No primary address is required for these commands. All devices equipment to implement these commands will do so simultaneously when the command is sent.

**Table 3-6. General Bus Command**

| Command | Addressing Required ? | HP-85 BASIC Statement |
|---------|-----------------------|-----------------------|
| REN     | Yes                   | REMOTE 724            |
| IFC     | No                    | ABORTIO 7             |
| GTL     | Yes                   | LOCAL 724             |
| DCL     | No                    | CLEAR 7               |
| SDC     | Yes                   | CLEAR 724             |
| GET*    | Yes                   | TRIGGER 724           |
| GET*    | No                    | TRIGGER 7             |

\*GET may be sent with or without addressing.

General bus commands are summarized in Table 3-6, which also lists the HP-85 BASIC statement that sends each command. Each addressed command statement assumes a primary address of 24.

**NOTE**

The Model 175 must be set for a primary address of 24 to work with addressed command examples.

**3.4.1 REN (Remote Enable)**

The remote enable command is sent to the Model 175 by the controller to set it up for remote operation. Generally, this should be done before attempting to program the instrument over the bus. The Model 175 will indicate that it is in the remote mode by displaying the RMT annunciator.

To place the Model 175 in the remote mode, the controller must perform the following steps:

1. Set the REN line low.
2. Address the Model 175 to listen.

**NOTE**

Setting REN true without addressing will not cause the RMT annunciator to turn on; however, once REN is true, the RMT annunciator will turn on the next time an addressed command is received.

**Programming Example**—This sequence is automatically sent by the HP-85 when the following is typed into the keyboard:

REMOTE 724 (END LINE)

After the END LINE key is pressed, the Model 175 RMT annunciator should come on. If not, check to see that the in-

strument is set for the proper primary address. Also, check to see that all bus connections are tight.

### 3.4.2 IFC (Interface Clear)

The IFC command is sent by the controller to set the Model 175 to the talk and listen idle states.

To send the IFC command, the controller need only set the IFC line true.

**Programming Example**—Before demonstrating the IFC command, turn on the RMT annunciator if it is not already on, by entering the following statements into the HP-85 computer:

REMOTE 724 (END LINE)

The RMT annunciator should now be on. The IFC command may now be sent by entering the following statement into the HP-85:

ABORTIO 7 (END LINE)

After the END LINE key is pressed, the Model 175 will be in the talk idle state.

### 3.4.3 GTL (Go To Local)

The GTL command is used to take the instrument out of the remote mode. To send the GTL command, the controller must perform the following sequence:

1. Set ATN true.
2. Address the Model 175 to listen.
3. Place the GTL command on the bus.

**Programming Example**—If the instrument is not in the remote mode, enter the following statement into the HP-85:

REMOTE 724 (END LINE)

Check to see that the RMT annunciator is on. The GTL command sequence is automatically sent by the HP-85 with the following statement:

LOCAL 724 (END LINE)

Note that the RMT annunciator turns off.

### NOTE

Setting REN false with the LOCAL 7 statement will also take the instrument out of the remote mode.

### 3.4.4 DCL (Device Clear)

The DCL command may be used to clear the Model 175, setting it to a known state. Note that all devices on the bus equipped to respond to a DCL will do so simultaneously. When the Model 175 receives a DCL command, it will return to the default conditions listed in Table 3-7.

To send the DCL command, the controller must perform the following steps:

1. Set ATN true.
2. Place the DCL command on the bus.

**Programming Example**—Place the instrument on the 200V range with the front panel controls. Also enable the REL and dB modes. Now enter the following statement into the HP-85:

CLEAR 7 (END LINE)

When the END LINE key is pressed, the instrument returns to power-up status.

### 3.4.5 SDC (Selective Device Clear)

The SDC command performs the same function as the DCL command except that only the addressed device responds. This command is useful for clearing only selected instruments instead of all instruments simultaneously. The Model 175 will return to the default conditions listed in Table 3-7 when responding to an SDC command.

To transmit the SDC command, the controller must perform the following steps:

1. Set ATN true.
2. Address the Model 175 to listen.
3. Place the SDC command on the data bus.

**Table 3-7. Default Conditions (Status Upon Power Up or After SDC or DCL)**

| Mode        | Value    | Status                          |
|-------------|----------|---------------------------------|
| Function    | —        | Reflects front panel selection. |
| Range       | —        | Reflects front panel selection. |
| Relative    | Z0       | Off                             |
| EOI         | K0       | Send EOI.                       |
| Trigger     | T0       | Continuous on Talk.             |
| SRQ         | M000     | Disabled                        |
| Data Format | G0       | Send prefix.                    |
| dB          | D0       | Off                             |
| Terminator  | Y(CR LF) | CR LF                           |
| Data Logger | —        | Unchanged (off)                 |

**Programming Example**—Using the front panel controls, place the instrument in the 200V measurement mode and enable the REL and dB modes. Now enter the following statement into the HP-85:

CLEAR 712 (END LINE)

Note that the instrument did not respond because the SDC command was sent with a primary address of 12. Now enter the following statement into the HP-85 keyboard:

CLEAR 724 (END LINE)

This time the instrument returns to the default conditions listed in Table 3-7.

### 3.4.6 GET (Group Execute Trigger)

The GET command is sent to the Model 175 to trigger the instrument. Using the GET command is only one of several methods that can be used to trigger readings. More detailed information on all trigger modes, including GET can be found in paragraph 3.5.5.

To send GET command over the bus, the controller must perform the following sequence:

1. Set ATN true.
2. Address the Model 175 to listen.
3. Place the GET command on the data.

GET can also be sent without addressing by omitting step 2.

**Programming Example**—Type in the following statement in the HP-85 keyboard:

REMOTE 724 (END LINE)

Place the instrument in the one-shot on GET trigger mode with the following statement:

OUTPUT 724 (END LINE)

When the END LINE key is pressed, the instrument will be waiting for a trigger.

The instrument may be triggered to take a single reading with the following statement:

TRIGGER 724 (END LINE)

When END LINE is pressed one reading will be processed.

#### NOTE

The Model 175 will also respond to GET without addressing. This command is sent with the following HP-85 statement:

TRIGGER 7

The preceding examples use device-dependent commands to place the instrument in the appropriate trigger modes. These commands are covered in detail in paragraph 3.5.

### 3.4.7 Serial Polling (SPE, SPD)

The serial polling sequence is used to obtain the Model 175 status byte. Usually, the serial polling sequence is used to determine which of several devices has requested service over the SRQ line. However, the serial polling sequence may

be used at any time to obtain the status byte format, refer to paragraph 3.5.8.

The serial polling sequence is conducted as follows:

1. The controller sets the ATN line true.
2. The SPE (Serial Poll Enable) command is placed on the bus by the controller.
3. The Model 175 is addressed to talk.
4. The controller sets ATN false.
5. The instrument then places its status byte on the bus to be read by the controller.
6. The controller then sets the ATN line low and places SPD (Serial Poll Disable) on the bus to end the serial polling sequence.

Steps 3 through 5 may be repeated for other instruments on the bus by using the correct talk address for each instrument. ATN must be true when the talk address is transmitted and false when the status byte is read.

**Programming Example**—The HP-85 SPOLL statement automatically performs the serial polling sequence. To demonstrate serial polling, momentarily power down the Model 175 and enter the following statements into the HP-85 keyboard.

REMOTE 724 (END LINE)  
S = SPOLL (724) (END LINE)  
DISP S (END LINE)

When END LINE is pressed the second time, the computer performs the serial polling sequence. When END LINE is pressed the last time, the status byte value is displayed on the CRT. Paragraph 3.5.8 covers the status byte format in detail.

## 3.5 DEVICE-DEPENDENT COMMAND PROGRAMMING

IEEE device-dependent commands are sent to the Model 175 to control various operating modes such as dB, relative, range and data format. Each command is made up of an ASCII alpha character followed by one or more numbers designating specific parameters. For example, dB is programmed by sending an ASCII "D" followed by a zero or one for turning it off or on. The IEEE bus treats device-dependent commands as data in that ATN is high when the commands are transmitted.

A number of commands may be grouped together in one string. A command string is terminated by an ASCII "X" character which tells the instrument to execute the command string.

If an illegal command or command parameter is present within a command string, the instrument will:

1. Ignore the entire command string.
2. Set appropriate error bits in the status byte.
3. Generate an SRQ if programmed to do so.

These programming aspects are covered in paragraph 3.5.8.

HP-85 examples are included throughout this section to clarify programming.

**NOTE**

Before performing a programming example, it is recommended that the instrument be set to its default values by sending an SDC over the bus. See paragraph 3.4.5 for information on using the SDC command.

If the HP-85 should become "hung up" at any point, operation may be restored by holding the SHIFT key down and then pressing RESET on the keyboard.

In order to send a device-dependent command, the controller must perform the following sequence.

1. Set ATN true.
2. Address the Model 175 to listen.
3. Set ATN false.
4. Send the command string over the data bus one byte at a time.

**Programming Example**—Device-dependent commands are sent by the HP-85 using the following statement:

OUTPUT 724;A\$ (END LINE)

A\$ in this case contains the ASCII characters that form the command string.

**NOTE**

REN must be true when attempting to program the Model 175. If REN is false, the RMT annunciator will be off.

Commands that affect the Model 175 are listed in Table 3-8. All the commands listed in Table 3-8 are covered in detail in the following paragraphs.

**NOTE**

Programming Examples that follow assume that the Model 175 primary address is at its factory setting of 24.

**Table 3-8. Device-Dependent Command Summary**

| Mode                | Command          | Description                              |
|---------------------|------------------|--|
| dB                  | D0               | dB off                                   |
|                     | D1               | dB on                                    |
| Range               | R0               | Volts Ohms                               |
|                     | R1               | Auto Auto                                |
|                     | R2               | 200m 200                                 |
|                     | R3               | 2 2k                                     |
|                     | R4               | 20 20k                                   |
|                     | R5               | 200 200k                                 |
| Relative            | Z0               | REL off                                  |
|                     | Z1               | REL on                                   |
| Trigger             | T0               | Continuous on talk.                      |
|                     | T1               | One-shot on talk.                        |
|                     | T2               | Continuous on GET.                       |
|                     | T3               | One-shot on GET.                         |
|                     | T4               | Continuous on X.                         |
| EOI                 | K0               | EOI enabled.                             |
|                     | K1               | EOI disabled.                            |
| Status Word         | U0               | Output status word.                      |
| SRQ Mode            | Mnn              | SRQ on error and/or data conditions      |
| Data Format         | G0               | Readings with prefix.                    |
|                     | G1               | Readings without prefix.                 |
| Digital Calibration | V ± n.nnnnE ± nn | n represents calibration value.          |
| Store               | L0               | Store Calibration Constants.             |
| Terminator          | Y(ASCII)         | ASCII character.                         |
|                     | Y(LF)            | CR LF                                    |
|                     | Y(CR)            | LF CR                                    |
|                     | Y(DEL)           | None                                     |
| Execute             | X                | Execute other device-dependent commands. |

### 3.5.1 Execute (X)

The execute command is implemented by sending an ASCII "X" over the bus. Its purpose is to tell the Model 175 to execute other device-dependent commands. Generally, the "X" character is the last byte in the command string. The execute character also controls instrument operation in the T4 and T5 trigger modes as described in paragraph 3.5.5.

#### NOTE

Command strings sent without an execute character will not be executed at that time, but they will be stored in the command buffer. The next time an execute character is received, the stored commands will be executed, assuming all commands in the previous string were valid.

**Programming Example**—Enter the following statement sequence into the HP-85 keyboard:

```
REMOTE 724 (END LINE)
OUTPUT 724; "X" (END LINE)
```

When the END LINE key is pressed the second time, the instrument receives the command. No changes will occur with this example because no other commands were given.

### 3.5.2 dB (D)

The dB function is the only function that can be programmed over the IEEE bus. The Model 175 must be manually set to DCV or ACV before dB can be enabled. The dB function is controlled by sending one of the following commands over the bus:

```
D0 = dB OFF
D1 = dB ON
```

Upon power-up, or after the instrument receives a DCL or SDC command, the D0 mode will be enabled.

**Programming Example**—Place the Model 175 in the DCV function from the front panel and enter the following statements into the HP-85 keyboard:

```
REMOTE 724 (END LINE)
OUTPUT 724; "D1X" (END LINE)
```

After the END LINE key is pressed the second time, the dB function will be enabled as indicated by the dB annunciator.

### 3.5.3 Range (R)

The volts and ohms ranges are programmable over the bus. The current ranges are not programmable. The Model 175 must be manually set to the volts (AC or DC) or ohms functions before the range commands can be effective. The range commands can be found in Table 3-8.

Upon power-up, or after receiving a DCL or SDC, the range

of the Model 175 will correspond to the range pushbutton pressed in.

**Programming Example**—Cycle power on the Model 175 and manually select the 2VDC function and range. Enter the following statements into the HP-85:

```
REMOTE 724 (END LINE)
OUTPUT 724; "R5X" (END LINE)
```

When END LINE is pressed the second time, the instrument switches to the R5 range (1000V).

#### NOTE

The other functions, except current can be selected without affecting the programmed range. If the amps (A) function is selected the Model 175 will switch to the correct range that corresponds to the range pushbutton pressed in. Range control over the bus will be terminated.

### 3.5.4 Relative (Z)

The REL mode serves as a means for a baseline suppression. When the correct REL command is sent over the bus, the instrument will enter the REL mode, as shown by the REL annunciator. All readings displayed or sent over the bus while REL is enabled are the difference between the stored baseline and the actual voltage level. For example, if a 100mV baseline is stored, 100mV will be subtracted from all subsequent readings as long as the REL mode is enabled. The value of the stored baseline can be a little as a few microvolts or as large as the selected range will permit. The REL mode is controlled by sending one of the following commands over the bus:

```
Z0 = REL Disabled
Z1 = REL Enabled
```

Upon power-up, or after DCL or SDC, Z0 is selected.

**Programming Example**—With the front panel REL button, disable the relative mode and enter the following statements into the HP-85 keyboard:

```
REMOTE 724 (END LINE)
OUTPUT 724; "Z1X" (END LINE)
```

After the END LINE key is pressed the second time, the REL annunciator will turn on.

#### NOTE

See the Model 175 Instruction Manual for detailed information on the use of the REL mode.

### 3.5.5 Triggering (T)

Triggering provides a stimulus to begin a reading conversion within the instrument. Triggering may be done in two basic ways: in a continuous mode, a single trigger command is

used to start a continuous series of readings; in a one-shot trigger mode, a separate trigger stimulus is required to start each conversion.

The Model 175 has six trigger commands as follows:

- T0 Continuous On Talk
- T1 One-Shot On Talk
- T2 Continuous On GET
- T3 One-Shot On GET
- T4 Continuous On X
- T5 One-Shot On X

Upon power-up or after a DCL or SDC command, the T0 mode is enabled.

In the T0 and T1 mode, triggering is done by addressing the Model 175 to talk. In the T2 and T3 modes, a GET command provides the trigger stimulus. In the T4 and T5 modes, the execute (X) character triggers the instrument.

**Programming Example**—Place the instrument in the one-shot on talk mode with the following HP-85 statement sequence:

```
REMOTE 724 (END LINE)
OUTPUT 724;"T1X" (END LINE)
```

After the END LINE key is pressed the second time, the instrument will be in the one-shot on talk trigger mode. The instrument is waiting for a trigger.

Trigger the instrument with a talk command by entering the following statement into the HP-85:

```
ENTER 724;A$ (END LINE)
```

After pressing END LINE one reading will be processed. To continue taking readings in this mode, one talk command must be sent for each conversion.

### 3.5.6 EOI (K)

The EOI line on the bus is usually set low by a device during the last byte of its data transfer sequence. In this way, the last byte is properly identified, allowing variable length data words to be transmitted. The Model 175 will normally send EOI during the last byte of its data string or status word. The EOI response of the instrument may be sent with one of the following commands:

- K0 sends EOI during last byte.
- K1 Send no EOI.

Upon power-up, the K0 mode is enabled.

**Programming Example**—Model 175 EOI response will be suppressed with the following HP-85 statement sequence:

```
REMOTE 724 (END LINE)
OUTPUT 724;"K1X"(END LINE)
```

Note that the HP-85 does not normally rely on EOI to mark the last byte of data transfer. Some controllers, however, may require that EOI be present at the end of transmitting.

### 3.5.7 Status Word (U)

The status word commands allow access to information concerning present operating modes of the instrument. When the status word command is given, the Model 175 will transmit status information instead of its normal data string the next time it is addressed to talk. Model 175 status word command is:

U0 Send instrument status on operating modes such as range, dB, etc.

Figure 3-7 shows the general format for the U0 command. The letters in the U0 format correspond to other device-dependent commands, such as Range (R), dB (D), etc.

#### NOTES:

1. Status word information will be returned only once each time the command is sent. Once status is read, the instrument will send its normal data string the next time it is addressed to talk.
2. The returned terminator character (Y) is derived by ANDing the byte with 00001111 and ORing the result with 00110000. For example, the last byte in the normal (CR LF) terminator sequence is a LF or ASCII 10 (00001010). ANDing with 00001111 yields 00001010. ORing with 00110000 gives 00111010 which is printed out as an ASCII colon(:).
3. The status word should not be confused with the status byte. The status word contains a number of bytes pertaining to the various operating modes of the instrument. The status byte is a single byte that is read with the SPE, SPD command sequence and contains information on SRQ status and error and data conditions.
4. The returned SRQ mode (M) value is determined by adding up the values of the bit positions in the status byte that could cause an SRQ according to the previously programmed value of the SRQ mode. (See paragraph 3.5.8 for complete information on the SRQ mask and status byte.)

**Programming Example**—Enter the program below into the HP-85. Be sure to include line numbers.

| PROGRAM                  | COMMENTS                                |
|--------------------------|---|
| 10 REMOTE 724            | Set up instrument for remote operation. |
| 20 OUTPUT 724; "U0X"     | Send U0 status command.                 |
| 30 ENTER 724; A          | Enter status word into computer.        |
| 40 DISP "****FRZKTMdMeY" |   |
| 50 DISP A                | Display on CRT.                         |
| 60 END                   |   |

After entering the program, press the HP-85 RUN key. The U0 status word will then be displayed on the CRT.

### 3.5.8 SRQ Mode (M) and Status Byte Format

The SRQ command controls which of a number of conditions within the Model 175 will cause the instrument to request service from the controller with the SRQ command. Once an SRQ is generated, the Model 175 status byte can be checked to determine if it was the Model 175 that requested service. Other bits in the status byte could also be set depending on certain data or error conditions.

The Model 175 can be programmed to generate an SRQ under one or more of the following conditions:

1. If a reading has been completed.
2. If an overflow condition occurs.
3. If a busy condition occurs.
4. If an Illegal Device-Dependent Command Option (IDDCO) is received.
5. If an Illegal Device-Dependent Command (IDDC) is received.
6. If the instrument is not in remote when a command is sent.

Upon power-up or after a DCL or SDC command, SRQ is disabled.

**SRQ Mask**—In order to facilitate SRQ programming, the Model 175 uses an internal mask to generate an SRQ. When a particular mask bit is set, the Model 175 will send an SRQ when those conditions occur. Bits within the mask can be controlled by sending the ASCII letter "M" followed by a decimal number to set the appropriate bits. Table 3-9 lists the commands to set the various mask bits, while Figure 3-8 shows the general mask format.

**Programming Example**—Cycle power on the Model 175 and program it for SRQ in IDDCO and output the status word.

| PROGRAM               | COMMENTS                      |
|-----------------------|-------------------------------|
| 10 REMOTE 724         | Set up for remote operation.  |
| 20 OUTPUT 724; "M33X" | Program for SRQ on IDDCO.     |
| 30 OUTPUT 724; "U0X"  | Send status command.          |
| 40 ENTER 724; A\$     | Enter commands into computer. |
| 50 DISP A\$           | Display on CRT.               |
| 60 END                |                               |

After entering the program, press the HP-85 run key. The U0 status word will then be displayed. The Me bytes (see Figure 3-7) will contain "01" indicating that the Model 175 is now programmed to SRQ on an IDDCO.

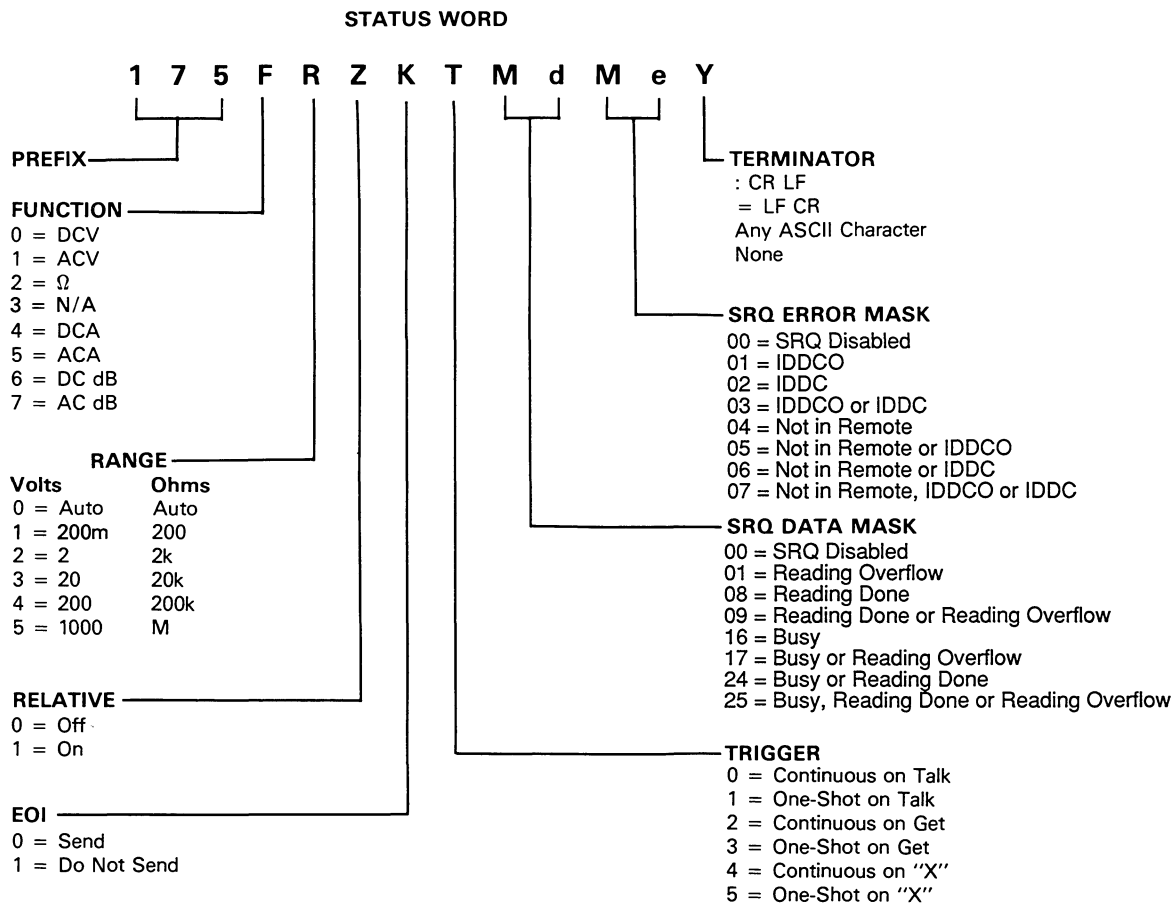

Figure 3-7. General Format for U0 Command

**Table 3-9. SRQ Mask Commands**

| Command | Status Bits Set | Conditions to Generate SRQ             |
|---------|-----------------|--|
| M0      | —               | Clear SRQ Data Mask                    |
| M1      | B0              | Reading Overflow                       |
| M8      | B3              | Reading Done                           |
| M9      | B3, B0          | Reading Done or Reading Overflow       |
| M16     | B4              | Busy                                   |
| M17     | B4, B0          | Busy or Reading Overflow               |
| M24     | B4, B3          | Busy or Reading Done                   |
| M25     | B4, B3, B0      | Busy, Reading Done or Reading Overflow |
| M32     | B5              | Clear SRQ Error Mask                   |
| M33     | B5, B0          | IDDCO                                  |
| M34     | B5, B1          | IDDC                                   |
| M35     | B5, B1, B0      | IDDC or IDDCO                          |
| M36     | B5, B2          | Not in Remote                          |
| M37     | B5, B2, B0      | Not in Remote or IDDCO                 |
| M38     | B5, B2, B1      | Not in Remote or IDDC                  |
| M39     | B5, B2, B1, B0  | Not in Remote, IDDC or IDDCO           |

Status Byte Format—The status byte contains information relating to data and error conditions within the instrument. When a particular bit is set, certain conditions are present. Table 3-10 lists the meanings of the various bits, and Figure 3-8 shows the general format of the status byte, which is obtained by using the SPE, SPD polling sequence described in paragraph 3.4.7.

If the status byte is read when no SRQ was generated by the Model 175 (bit 6 clear), the current status of the instrument will be read. For example, if a reading was done, bit 3 would be set.

When a SRQ is generated by the Model 175, bit 6 of the status byte will be set. If the SRQ was caused by an error condition, bit 5 will also be set along with one of the error condition bits (B0, B1, or B2). Only the error that caused the initial SRQ will be defined by the status byte.

If the SRQ was caused by a data condition, bit 5 will be clear and the appropriate data condition bits (B0, B3 and B4) will be set. If the busy condition caused the SRQ, then only the busy bit will be set.

After an SRQ, the status byte will remain unchanged until it is read.

The various bits in the status byte are described below:

1. Reading Overflow—Set when an overrange input is applied to the instrument.
2. Reading Done—Set when the instrument has completed the present conversion and is ready to take another reading.
3. Busy—The instrument is still executing a prior command and is not ready to accept a new command.
4. IDDCO—An illegal command option such as R6 has been sent. This bit is cleared when the status byte is read.

5. IDDC—An illegal command will set this bit. For example, N1 is illegal since no such letter exists in the command set. The IDDC bit will be cleared on a reading of the status byte.
6. Not in remote-Model 175 in local mode of operation.

**NOTES:**

1. Once the Model 175 has generated an SRQ, its status byte must be read to clear the SRQ line. Otherwise the instrument will continuously assert SRQ.
2. The Model 175 may be programmed to generate an SRQ for more than one condition simultaneously.

**Programming Example**—Enter the following program into the HP-85:

| PROGRAM                        | COMMENTS                                   |
|--------------------------------|--|
| 10 REMOTE 724                  | Set up for remote operation.               |
| 20 OUTPUT 724; "M33X"          | Program for SRQ on IDDCO.                  |
| 30 OUTPUT 724; "R6X"           | Attempt to program illegal command option. |
| 40 S=SPOLL (724)               | Perform serial poll.                       |
| 50 DISP "B7B6B5B4B3<br>B2B1B0" |  |
| 60 FOR I=7 TO 0 STEP -1        | Loop eight times.                          |
| 70 DISP BIT (S,I);             |  |
| 80 NEXT I                      |  |
| 90 DISP                        |  |
| 100 END                        |  |

Press the HP-85 RUN key. The computer conducts a serial poll and displays the status byte bits in order on the CRT. The SRQ (B6), error (B5), and IDDCO (B0) bits are set because line 30 of the program attempted to program the instrument with an illegal command option (R6).

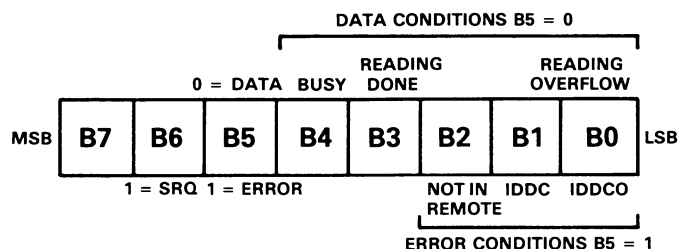

Figure 3-8. Status Byte Format

Table 3-10. Status Byte and Mask Interpretation

| Bit     | Bit 5=0<br>(Data Conditions) | Bit 5=1<br>(Error Conditions) |
|---------|------------------------------|-------------------------------|
| 0 (LSB) | Overflow                     | IDDCO                         |
| 1       | N/A                          | IDDC                          |
| 2       | N/A                          | No remote                     |
| 3       | Reading done                 | N/A                           |
| 4       | Busy                         | N/A                           |
| 5       | Data                         | Error                         |
| 6       | SRQ                          | SRQ                           |
| 7       | N/A                          | N/A                           |

### 3.5.9 Data Format

Model 175 data is transmitted over the bus as a string of ASCII characters with the format shown in Figure 3-9. The first character indicates the function. The mantissa of the reading is made up of 7 characters, including sign and decimal point, while the exponent requires three characters. To obtain the data string from the instrument, the controller must perform the following sequence:

1. Set ATN low.
2. Address the instrument to talk.
3. Set ATN high.
4. Input the data string one byte at a time.

#### NOTE

The data string can be outputted without the prefix 175. See paragraph 3.5.10 for more information.

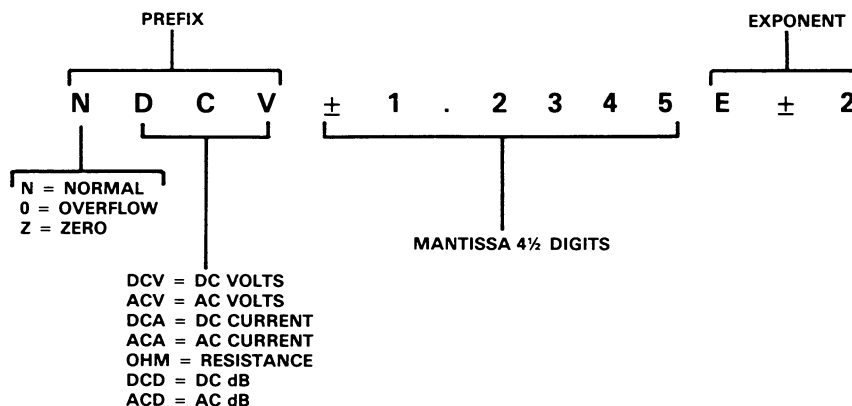

Figure 3-9. Data Format

**Programming Example**—Cycle power on the Model 175 and program it to output a data string.

| PROGRAM          | COMMENTS                     |
|------------------|------------------------------|
| 10 REMOTE 724    | Set for remote operation.    |
| 20 ENTER 724;A\$ | Enter command into computer. |
| 30 DISP A\$      | Display on CRT.              |
| 40 END           |                              |

Press the run key of the HP-85 and the data string will be displayed.

### 3.5.10 Prefix (G)

With the use of the G command, the prefix 175 for the status word or data string can be either transmitted or deleted. The commands are as follows:

- G0 Include Prefix
- G1 Suppress Prefix

Upon power-up or after a DCL or SDC command, the G0 mode is enabled.

**Programming Example**—Program the Model 175 to output a data string without the prefix.

| PROGRAM              | COMMENTS                     |
|----------------------|------------------------------|
| 10 REMOTE 724        | Set for remote operation.    |
| 20 OUTPUT 724; "G1X" | Suppress prefix command.     |
| 30 ENTER 724; A\$    | Enter command into computer. |
| 40 DISP A\$          | Display on CRT.              |
| 50 END               |                              |

Press the HP-85 run key. The data string will be displayed without the prefix.

### 3.5.11 Programmable Terminator (Y)

The Model 175 uses special characters to mark the end of its data string or status word. The terminator can be changed to allow a variety of controllers to be used. The default value is carriage return, line feed (CR LF). This is the value upon power-up or after the instrument receives a DCL or SDC.

The terminator is programmed by sending the ASCII character Y and the desired terminator character. Any ASCII character except the following may be used:

Any capital letter. Any number. Blank. + - / , . or e

Special command characters program the instrument for special terminator sequences as follows:

1. Y(LF) = CR LF (Two terminators)
2. Y(CR) = LF CR (Two terminators)
3. Y(DEL) = No terminator

#### NOTE

Most controllers use CR or LF to terminate their input sequence. Using a nonstandard terminator may cause the controller to hang up unless special programming is used.

**Programming Example**—The terminator can be eliminated by sending an ASCII DEL with the following HP-85 statements:

```
REMOTE 724
OUTPUT 724;"Y";CHR$(127);"X"
```

When the second line is entered, the terminator is suppressed; no terminator is sent by the instrument when data is requested.

### 3.5.12 Digital Calibration (V) and Storage (L)

If you have Revision C software in your Model 175, then you have an external calibration switch on the rear panel that needs to be placed in "ENABLED" before calibration begins.

To determine what software revision level your instrument has, hold in the dB button and turn on the Model 175. First, all LCD digits and annunciators turn on, then the software revision level is displayed. The instrument then runs a display test and goes into troubleshooting diagnostics. Cycle power to return the unit to normal operation.

#### NOTE

For Revision A and B software, contact the factory for calibration information.

The Model 175 is shipped from the factory with its external calibration switch in DISABLED. In this position, calibration constants cannot be stored when entered from the front panel or over the IEEE-488 bus.

The calibration switch is located in the middle of the rear panel. Slide the switch to ENABLED.

Use the V command to place the instrument in calibration and transmit a calibration value. Commands with values up to the range selected on the front panel or below are accepted. The display of the Model 175 indicates that the instrument has entered calibration by the "C" annunciator.

If commands with values higher than the front panel range are selected, then they and all other commands in the string are ignored and the instrument will not enter calibration.

The following calibration command transmits the calibration value to the instrument:

$$V + n.nnnnE + nn$$

where:

+n.nnnn represents the mantissa (4-1/2 digits)  
E + nn represents the exponent

The L0 command permanently stores the calibration values. When the command is sent, the message "Stor" is displayed briefly indicating that permanent storage has occurred. If the message "out" is displayed, then calibration storage was not enabled and the calibration constants are only valid until the Model 175 is turned off.

NOTES:

1. Only enter as many significant digits as necessary. For example, use the following command for calibration of the 20V range with a 19.000V input value:  
V19X
2. The correct calibration signal must be applied to the instrument before the calibration command can be sent.
3. The calibration enabled switch can be changed at any time to enable the storage of calibration constants.

**Programming Example**—Since the following example is for demonstration purposes only, the calibration constants will not be permanently stored.

#### CAUTION

**Place the calibration switch in DISABLED to ensure that permanent storage of the calibration constants cannot occur. Failure to do so could seriously affect instrument accuracy.**

Select the 2VDC range. Connect a precise 1.9000VDC calibration voltage to the input terminals and enter the following statements into the HP-85:

```
REMOTE 724
OUTPUT 724;"V1.9X"
OUTPUT 724;"L0X"
```

When the second line is entered, the "C" annunciator turns on to indicate that the instrument is in calibration. The display shows the calibration value entered in the V command, indicating the unit is calibrated to the input signal.

When the third line is entered, the unit displays the message "out" and the "C" annunciator blinks, indicating that the calibration constants were not permanently stored. The calibration constants will be lost when the instrument is turned off. (If storage had been selected, the constants would be stored and the message "Stor" would have been displayed.)

### 3.6 TALK ONLY OPERATION

The talk only mode may be used to send data to a listen only device such as a printer. When the Model 175 is in the talk only mode, it ignores commands sent over the bus. Enable talk only by placing the TO/ADDRESSABLE switch in the TO position (see Figure 3-6).

### NOTE

The status of the TO/ADDRESSABLE switch is read-only upon power-up. If the switch position is changed, the instrument must be momentarily powered down before it will recognize the new switch condition (the positions of the address switches are not important). Sending commands to the instrument when it is in the talk only mode may cause the controller to hang-up.

When the Model 175 is used in the talk only mode, it may be interfaced with one or more listeners. Each of these devices and associated cabling should conform to IEEE-488-1978 standards.

The Model 175 will transmit its normal data string in bit-parallel byte-serial fashion over the bus as requested by the listeners. The data format is the same one used for Addressable operation and is described in detail in paragraph 3.5.9. If the address switches are set to an odd number the prefix will be sent with the reading. An even address number will send only the data.

The default talk rate is 3 readings per second (every reading). However, a different talk rate can be selected by performing the following procedure.

1. Press and hold the STO/CLR pushbutton. The following talk rates will scroll on the display.  
r = 0 (every reading)  
r = 1 (every rdg/sec)  
r = 2 (1rdg/10sec)  
r = 3 (1rdg/min)  
r = 4 (1rdg/10min)  
r = 5 (1rdg/hr)
2. Release the STO/CLR pushbutton when the desired talk rate is displayed. The STO annunciator will turn on and the instrument will talk at the selected rate.
3. Turn off the Data Logger by again pressing the STO/CLR button. The STO annunciator will turn off.

### NOTE

The instrument will continue to talk at the selected rate until either a new rate is entered or power is cycled.

## 3.7 CONTROLLER PROGRAMS

The Model 175 is easily connected to a wide variety of system controllers through the Model 1753 interface. System instrument designs have been thoroughly checked out with a number of different controllers to ensure complete compatibility.

Most of the programming functions throughout this manual use HP-85 examples. This section gives additional programming information for using the Model 175 with various other controllers.

Each of the programs in this section are designed to be a simple aid to the user, and is not intended to suit specific needs. More detailed programming information can be found throughout this manual.

These programs display one reading at the controller output, which is usually a CRT display. The data format is an ASCII string with the form:

$$\text{NDCV} \pm 0.0000 \text{ E} \pm 0 \text{ CR LF}$$

A note with each program indicates modifications to change the string into a numeric equivalent of the form:

$$\pm 0.0000 \text{ E} \pm 0$$

### 3.7.1 APPLE II (APPLE Interface)

The program below obtains one reading from the Model 175 and displays the reading on the APPLE II screen, using an APPLE IEEE-488 interface.

#### Directions

1. Set switches on the Model 175 to the addressable mode, primary address 24.
2. Connect the Model 175 to APPLE II and APPLE IEEE-488 interface.
3. Set the Model 175 to DCV and AUTO range.
4. Enter the program below using the RETURN key after each line.
5. Type in RUN and depress RETURN key.
6. The display will read "TEST SETUP".
7. To program the Model 175 to the 2V range and take a reading, type in R2T1X and depress the RETURN key.
8. Display will read NDCV + 0.0000 E + 0 for "0" volts in. (Short Input)

| PROGRAM                              | COMMENTS   |
|--------------------------------------|--|
| 10 DIM A\$(20),B\$(20)               | Dimension data string.                                 |
| 20 Z\$=CHR\$(26)                     | Terminator.  |
| 30 INPUT "TEST<br>SETUP?";B\$        | Enter programming command<br>Example: 2V range = R2T1X |
| 40 PR#3                              | Send output to IEEE bus.                               |
| 50 IN#3                              | Get input from IEEE bus.                               |
| 60 PRINT "RA"                        | Turn remote on.  |
| 70 PRINT "WT8";<br>Z\$;B\$           | Write B\$ to 175.                                      |
| 80 PRINT "LF1"                       | Linefeed on.   |
| 90 PRINT "RDX";Z\$;<br>INPUT " ";A\$ | Read data from 175.                                    |
| 100 PRINT "UT"                       | Untalk.  |
| 110 PR#0                             | Send output to CRT.                                    |
| 120 IN#0                             | Get input from keyboard.                               |
| 130 PRINT A\$                        |  |
| 140 GOTO 30                          | Repeat.  |

NOTE: If conversion to numeric variable is desired, add the following:

|                            |                                  |
|----------------------------|----------------------------------|
| 134 A=VAL(MID\$(A\$,5,11)) | Convert string to numeric value. |
| 136 PRINT A                |                                  |

### 3.7.2 HP 85

The program below obtains one reading from the Model 175 and displays the reading on the HP 85 CRT screen, using the 82937A GPIB Interface and an I/O ROM.

#### Directions

1. Set switches on the Model 175 to the addressable mode, primary address 24.
2. Connect the Model 175 to the HP 82937A IEEE Interface.
3. Set the Model 175 to DCV and AUTO range.
4. Enter the program below using the END LINE key after each line is typed.
5. Depress the RUN key.
6. The display will read "TEST SETUP".
7. To program the Model 175 to the 2V range and take a reading, type in R2T1X and depress the END LINE key.
8. Display will read NDCV + 0.0000 E + 0 for "0" volts in. (Short Input)

| PROGRAM                | COMMENTS                       |
|------------------------|--------------------------------|
| 10 DIM A\$(20),B\$(20) | Dimension data string          |
| 20 REMOTE 724          | Set to remote.                 |
| 30 DISP "TEST SETUP"   | Prompt for test setup.         |
| 40 INPUT B\$           |                                |
| 50 OUTPUT 724; B\$     | Program the 175.               |
| 60 ENTER 724; A\$      | Get the data from the 175 DMM. |
| 70 DISP A\$            |                                |
| 80 GO TO 30            | Repeat.                        |
| 90 END                 |                                |

NOTE: If conversion to numeric variable is needed, change line 70 as follows:

|                     |  |
|---------------------|--|
| 70 DISP VAL(A\$(5)) |  |
|---------------------|--|

### 3.7.3 HP 9816

The following program sends a command, reads data from the Model 175 and displays the reading on the HP 9816 screen, using BASIC 2.0.

#### Directions

1. Set address switches to primary address 24.
2. Connect the Model 175 to the HP 9816.
3. Set the 175 to DCV and AUTO range.
4. Enter the program below using the ENTER key after each line is typed.
5. Depress the RUN key.
6. The display will read "TEST SETUP".
7. To program the Model 175 to the 2V range and read data, type in R2T1X and depress the ENTER key.
8. The display will read NDCV + 0.0000 E + 0 for "0" volts in.

| PROGRAM                   | COMMENTS                    |
|---------------------------|-----------------------------|
| 10 REMOTE 724             | Set to remote.              |
| 20 INPUT "TEST SETUP",A\$ | Prompt for test setup.      |
| 30 OUTPUT 724;A\$         | Program the 175.            |
| 40 ENTER 724; B\$         | Read the data from the 175. |
| 50 PRINT B\$              |                             |
| 60 GO TO 20               | Repeat                      |
| 70 END                    |                             |

NOTE: For conversion to numeric variable, change lines 40 and 50 as follows:

|                |  |
|----------------|--|
| 40 ENTER 724;A |  |
| 50 PRINT A     |  |

### 3.7.4 HP 9825A

The program below obtains one reading from the Model 175 and displays the reading on the HP 9825A using a 98034A HPIB interface and a 9872A extended I/O ROM.

#### Directions

1. Set switches on the Model 175 to addressable mode, primary address 24.
2. Connect the Model 175 to HP 9825A and HP 98034A HPIB interface.
3. Set the Model 175 for DCV and AUTO range.
4. Enter the program below, using the STORE key after each line is typed. Line numbers are automatically assigned by the 9825A.
5. Depress the RUN key.
6. The display will read "TEST SETUP".
7. To program the Model 175 to the 2V range and take a reading, type in R2T1X and depress the CONT key.
8. Printer will read NDCV + 0.0000 E + 0 for "0" volts in.

| PROGRAM               | COMMENTS  |
|-----------------------|---|
| 0 dim A\$(20),B\$(20) | To dimension data string.                                 |
| 1 dev "175",724       | Define Model 175 channel A address.                       |
| 2 rem "175"           | Set to remote.  |
| 3 ent"TEST SETUP",A\$ | Enter programming command. (Example: 2VDC range = R2T1X.) |
| 4 wrt "175",A\$       | Output program command to Model 175 via IEEE bus.         |
| 5 red"175",B\$        | Read data from Model 175 via IEEE bus.                    |
| 6 prt B\$             | Print data on hard copy printer.                          |
| 7 gto 3               | Repeat.   |

NOTE: If conversion to numeric variable is desired, omit lines 6 and 7 and substitute:

|                        |                           |
|------------------------|---------------------------|
| 6 "e"→B\$(13,13); flt5 | Convert to numeric value. |
| 7 prt val(B\$(5))      |                           |
| 8 gto 3                | Repeat.                   |

### 3.7.5 HP 9826

The program below obtains one reading from the Model 175 and displays the reading on the HP 9826 screen, using the BASIC ROMs.

#### Directions

- Using address switches, select primary address 24.
- Connect the Model 175 to the HP 9826.
- Set the Model 175 for DCV and AUTO range.
- Enter the program below using the ENTER key after each line is typed.
- Depress the RUN key.
- The display will read "TEST SETUP".
- To program the Model 175 to the 2V range and take a reading, type in R2T1X and depress the END LINE key.
- Display will read NDCV + 0.0000 E + 0 for "0" volts in. (Short Input)

| PROGRAM               | COMMENTS                   |
|-----------------------|----------------------------|
| 10 REMOTE 724         | Set to remote.             |
| 20 PRINT "TEST SETUP" | Prompt for test setup.     |
| 30 INPUT B\$          |                            |
| 40 OUTPUT 724; B\$    | Program the 175.           |
| 50 ENTER 724; A\$     | Get the data from the 175. |
| 60 PRINT A\$          |                            |
| 70 GO TO 20           | Repeat                     |
| 80 END                |                            |

NOTE: If conversion to numeric variable is needed, change lines 50 and 60 as follows:

|                |  |
|----------------|--|
| 50 ENTER 724;A |  |
| 60 PRINT A     |  |

### 3.7.6 IBM Personal Computer XT or PC (National Instruments GPIB-PC)

The following program sends a command string to the Model 175 and displays the reading on the IBM personal computer display. The equipment required for this program is the IBM personal computer XT or PC, the National Instruments GPIB-PC interface and the DOS 2.00 operating system. The GPIB software and hardware must be installed and configured per the National Instruments GPIB-PC instruction manual.

#### Directions

- Using rear panel switches, set primary address 24 on the Model 175.
- Connect the Model 175 to the GPIB-PC interface with power off.
- Turn on the Model 175 and set to DCV and AUTO range.
- Type in the command BASIC on the IBM keyboard to get into the IBM interpretive BASIC language.
- Type in the command LOAD "DECL" to prepare the

system for programming. The LOAD "DECL" command takes up the first five lines of the program. Refer to the program.

- Type in the following program starting with line 10.
- Type in RUN to execute the program.
- The display will read "TEST SETUP".
- To program the Model 175 to the 2V range and take a reading, type in R2T1X and press the return key.
- The display will read NDCV + 0.0000 E + 0 for "0" volts in. (Short Input)

| PROGRAM   | COMMENTS   |
|---|--|
| 1 CLEAR, 60000!   | The first five lines do not have to be typed in. Typing in LOAD "DECL" accomplishes this task. |
| 2 IBINIT = 60000!   |  |
| 3 BLOAD "bib.m",<br>IBINIT  |  |
| 4 IBSTA% = 0:IBCNT<br>% = 0:IBERR% = 0  |  |
| 5 CALL IBINIT (IBRD%,IBWRT%,<br>IBCMD%,IBWAIT%,IBRPP%,<br>IBONL%,IBRSC%,IBSIC%,<br>IBSRE%,IBRTL%,IBRSV%,<br>IBLPE%,IBPAD%,IBSAD%,<br>IBIST%,IBDMA%,IBEOS%,<br>IBTMO%,IBEOT%,IBGTS%,<br>IBCAC%,IBDIAG%,IBSTA%,<br>IBERR%,IBCNT%) |  |
| 10 BD% = 0 '  | Interface board number is 0.   |
| 20 CLS  |  |
| 30 RD\$ = SPACE\$(25) '   | Data buffer = 25 bytes.  |
| 40 V% = 0 : CALL IBPAD%<br>(BD%,V%) '   | Primary address of GPIB is 0.  |
| 50 CALL IBSIC%(BD%) '   | Interface clear.   |
| 60 V% = 1 : CALL IBSRE%<br>(BD%,V%) '   | Set 175 to remote.   |
| 70 CMD\$ = "@8" '   | Listen address of 175.   |
| 80 INPUT "TEST SETUP";<br>C\$ '   | Prompt for command.  |
| 90 CALL IBCMD%(BD%,CMD\$) '   | Address 175 to listen  |
| 100 CALL IBWRT%(BD%,C\$) '  | Send command string to 175.  |
| 110 CMD\$ = " X" '  | Talk address of 175  |
| 120 CALL IBCMD%(BD%,CMD\$) '  | Address 175 to talk.   |
| 130 CALL IBRD%(BD%,RD\$) '  | Get data string from 175.  |
| 140 PRINT RD\$ '  | Print data string.   |
| 150 GOTO 70 '   | Repeat.  |

### 3.7.7 IBM Personal Computer XT or PC (Tecmar IEEE-488 Interface)

The following program sends a command string to the Model 175 and displays the reading on the IBM personal computer display. The equipment required for this program is the IBM personal computer XT or PC, the Tecmar IEEE-488 interface,

the Tecmar IEEE-488 software support package (Version 1.1) and the DOS 2.00 operating system. The GPIB software and hardware must be installed and configured per the Tecmar IEEE-488 instruction manual.

**Directions**

1. Using rear panel switches, set primary address to 24 on the Model 175.
2. Connect the Model 175 to the GPIB-PC interface with power off.
3. Set the Model 175 for DCV and AUTO range.
4. Turn computer on with DOS disk installed and enter time and date when prompted.
5. Insert TECMAR disk into drive and type "ASM488". (Press return)
6. Insert DOS disk into drive and type "BASIC". (Press return to get into the IBM interpretive BASIC language.)
7. Insert TECMAR disk back into drive and type LOAD "IEEESP". (Press return to enter initialization commands.) Lines 2 through 88 will load into memory.
9. Type in RUN to execute the program.
10. The display will read "TEST SETUP."
11. To program the Model 175 to the 2V range and take a reading, type in R2T1X and depress the return key.
12. The display will read NDCV + 0.0000 E + 0 for "0" volts in. (Short Input)

| PROGRAM  | COMMENTS  |
|--|---|
|  | The first group of lines do not have to be typed in. Typing LOAD "IEEESP" accomplishes this task. |
| 100 MY.ADDR% = 7:BD.<br>ADDR% =<br>&H310                   | GPIB ADD. 7 & I/O<br>ADD.<br>FACTORY = 310HEX)  |
| 110 CLS  |   |
| 120 LAD%(0) = 24:LAD%(1) = 199                             | LISTEN ADD. &<br>ARRAY TER-<br>MINATOR.   |
| 130 TAD%(0) = 24:TAD%(1) = 199                             | TALK ADD. &<br>ARRAY TER-<br>MINATOR.   |
| 140 TCIMODE% = 1:MS% = 10                                  | CONFIGURE GPIB<br>FOR INTERRUPTS.   |
| 150 TERM% = 2:EOS% = 10:<br>ER% = 0                        | TERM. SPECIFIER,<br>ASCII EQUIV.(LF),<br>ERROR VAR.   |
| 160 DEF SEG = CSEG   | CSEG = SEGMENT<br>ADD. OF THE ASM -<br>488 ROUTINE.   |
| 170 CALL INIT%(MS%,<br>TCIMODE%,MY.ADDR%,<br>BD.ADDR%,ER%) | INITIALIZE THE<br>GPIB.   |
| 180 ATA\$ = SPACE\$(25)                                    | DATA BUFFER = 25<br>BYTES.  |

|   |  |
|---|--|
| 190 CALL SDR%(LAD%(0),<br>ER%)                                    | SET REMOTE LINE<br>ACTIVE.                                 |
| 200 STRNUM% = 1   | ONE STRING PER<br>READ OR WRITE.<br>PROMPT FOR<br>COMMAND. |
| 210 INPUT "TEST SETUP<br>";BATA\$                                 | SEND COMMAND<br>TO 175.                                    |
| 220 CALL WRSTR% (EOS%,<br>TERM%,LAD%(0),BATA\$,<br>STRNUM%,ER%) ' |  |
| 230 CALL RDSTR% (EOS%,<br>TERM%,TAD%(0),ATA\$,<br>STRNUM%,ER%) '  | GET DATA FROM<br>175.                                      |
| 240 PRINT ATA\$   | PRINT DATA<br>STRING.<br>REPEAT.                           |
| 250 GOTO 210  |  |

**3.7.8 DEC LSI 11**

The program below obtains one reading from the Model 175 and displays the reading on the DEC LSI 11 microcomputer CRT terminal. The LSI 11 must be configured with 16k words of RAM and an IBV 11 IEEE interface. The software must be configured with IB software as well as the FORTRAN and the RT 11 operating system

**Directions**

1. Set switches on the Model 175 to addressable mode, primary address 24.
2. Connect the Model 175 to the IBV II IEEE cable.
3. Set the Model 175 to DCV and AUTO range.
4. Enter the program below, using the editor under RT 11 and the name IPHILD.
5. Compile using the FORTRAN compiler as follows: FORTRAN IPHILD
6. Link with the system and IB libraries as follows: LINK IPHILD, IBLIB
7. Type RUN IPHILD and depress the RETURN key.
8. The display will read "ENTER ADDRESS".
9. To program the Model 175 to the 2V range and take a reading, type in R2T1X and depress RETURN key.
10. Display will read NDCV + 0.0000 E + 0 for "0" volts in.

| PROGRAM                             | COMMENTS                  |
|-------------------------------------|---------------------------|
| DO 2 I = 1, 10                      |                           |
| CALL IBSTER (I,0)                   | !Turn off IB errors.      |
| 2 CONTINUE                          |                           |
| CALL IBSTER (15,5)                  | !Allow 5 error 15's.      |
| CALL IBTIMO (120)                   | !Allow 1sec. bus timeout. |
| CALL IBTERM ("10)                   | !Set LF as terminator.    |
| CALL IBREN                          | !Turn remote on.          |
| 4 TYPE 5                            |                           |
| 5 FORMAT (1X,'ENTER<br>ADDRESS',\$) | !Input the address 24.    |
| ACCEPT 10, PRIADR                   |                           |
| 10 FORMAT (214)                     |                           |
| 12 TYPE 15                          |                           |

```

15 FORMAT (1X,'TEST      !Prompt for the test setup.
   SETUP',\$)
   CALL GETSTR (5,      !Get the test setup.
   MSG,72)
   CALL IBSEOI (MSG,-1 !Program the 175.
   PRIADR)
18 I=IBRECV (INPUT,80, !Get the data from the 175.
   PRIADR) INPUT
   (I + 1) = 0
   CALL PUTSTR (7,
   INPUT,'0')
   CALL IBUNT          !Untalk the 175.
   GO TO 12           !Repeat.
   END

```

```

50 For N = 1 TO 350
60 Next N
70 IF ST=2 THEN 40      If time out, input again.
80 PRINT A$             Print data.
90 GO TO 20             Repeat.
NOTE: If conversion to numeric variable is desired, omit line
      90 and type the following:
90 A = VAL(MID$(A$,5,15)) Convert string to numeric
                           value.
100 PRINT "A="; A
110 GO TO 20            Repeat.

```

### 3.7.9 PET/CBM 2001

The program below obtains one reading from the Model 175 and displays the reading on the PET/CBM 2001 Series.

#### Directions

1. Set switches on the Model 175 to addressable mode, primary address 24.
2. Connect the Model 175 to PET/CBM 2001 IEEE interface.
3. Set the Model 175 to DCV and AUTO range.
4. Enter the program below using the RETURN key after each line.
5. Type RUN and depress the RETURN key.
6. The display will read "TEST SETUP".
7. To program the Model 175 to the 2V range and take a reading, type in R2T1X and depress the RETURN key.
8. Display will read NDCV + 0.0000 E + 0 for "0" volts in. (Short Input)

| PROGRAM                    | COMMENTS   |
|----------------------------|--|
| 10 OPEN 6,24               | Open file 6, primary address 24.                           |
| 20 INPUT "TEST SETUP"; B\$ | Enter programming command. (Example: 2V DC range = R2T1X.) |
| 30 PRINT#6,B\$             | Output to the IEEE bus.                                    |
| 40 INPUT#6,A\$             | Read data from Model 175 via IEEE bus.                     |

### 3.7.10 TEK 4052

The program below obtains one reading from the Model 175 and displays the reading on the TEK 4052 graphics terminal, with a TEK 4051 GPIB interface.

#### Directions

1. Set switches on the Model 175 to the addressable mode, primary address 24.
2. Connect the Model 175 to TEK 4051 IEEE interface.
3. Set the Model 175 for DCV and AUTO range.
4. Enter the program below using the RETURN key after each line.
5. Type in RUN.
6. The display will read "TEST SETUP".
7. To program the Model 175 to the 2V range and take a reading, type in R2T1X and depress the RETURN key.
8. Display will read NDCV + 0.0000 E + 0 for "0" volts in.

| PROGRAM  | COMMENTS                   |
|--|----------------------------|
| 5 PRINT @ 37,0: 10,255,13  |                            |
| 10 PRINT "TEST SETUP"  | Prompt for the test setup. |
| 20 INPUT A\$   |                            |
| 30 PRINT @ 24:A\$  | Program the 175.           |
| 40 INPUT % 24: B\$   | Get the data from the 175. |
| 50 PRINT B\$   |                            |
| 60 GO TO 10  | Repeat                     |
| NOTE: If conversion to numeric value is needed, change lines 40 and 50 to: |                            |
| 40 INPUT % 24:A  |                            |
| 50 PRINT A   |                            |

## **SECTION 4 THEORY OF OPERATION**

### **4.1 INTRODUCTION**

This section contains the basic circuit description of the Model 1753. The IEEE-488 interface option enables the Model 175 to be incorporated into a measurement system that utilizes programmed control through the IEEE-488 bus. Explanation of the complicated software is beyond the scope of this section.

### **4.2 CIRCUIT DESCRIPTION**

The entire IEEE-488 interface circuitry is located on a single PCB (Schematic 1753-106). The heart of the IEEE option is the General Purpose Interface Bus Adapter (U104) and the microprocessor (U101). The GPIBA is capable of performing all IEEE Talker/Listener protocols. The bidirectional data lines D0 through D7 permit the transfer of data between the microprocessor and the GPIBA. The transceiver U105 and U107 are used to drive the output. Data is buffered by U105 and U107 and is transmitted to the bus via connector J1007.

The primary address switches (S101) select the primary address, and permit selection of 31 primary Talker/Listener address pairs. To address the Model 175 the controller must send the primary address of the Model 175. The factory set primary address of the Model 175 is 24 (11000). The microprocessor reads the primary address from S101 and then knows which Talker/Listener address to assign the GPIBA (U104) and thus the Model 175

#### **NOTE**

The primary address is updated only upon power up.

This section is accessed with the address switch enable (AS) signal. The AS signal is derived from the microprocessor (U101) and enables the three state latch U103. Enabling U103 places the address on the data bus (D0-D4 and D7).

The opto-isolators (U109 and U111) isolate the Model 175 from earth ground which may be picked up from the controller or one of the instruments on the IEEE bus.



# SECTION 5 MAINTENANCE

## 5.1 INTRODUCTION

This section contains information necessary to maintain the Model 1753. Installation procedures, troubleshooting information and instructions concerning care in handling static sensitive devices are included.

### WARNING

**All service information is intended for qualified electronic maintenance personnel only.**

## 5.2 INSTALLATION

The Model 1753 is field installable. To install the Model 1753 into a Model 175 use the following procedure and refer to Figure 6-1:

### WARNING

**To prevent a shock hazard, unplug the line cord and all test leads from the instrument before removing the top cover.**

1. Remove and retain the top cover. The top cover is secured by four screws accessible from the bottom of the instrument.
2. Install the rear standoff by positioning it over the hole in the PC board, as shown in Figure 6-1, and pressing firmly until it snaps securely into the board.
3. Install the cable clamp so that there will be no slack in the display cable under the IEEE board. The display cable must not touch the IEEE board.
4. Position the Model 1753 loosely on the rear standoff.

### WARNING

**Do not push down on J1008. The male connector pins will pass through J1008 and may cause personal injury.**

5. Guide the terminals of P1008 into J1008 and firmly push down on that end of the board to mate the connectors.
6. Push down on the other side of the IEEE board until it snaps onto the rear standoff. Make sure the board is seated properly on the front stand off.
7. Install the modified top cover.

### WARNING

**If the Model 1753 is removed, use the original top cover supplied with the Model 175 (if available). If the modified top cover is used, cover the holes normally occupied by the IEEE connector and switch. Failure to cover these holes could result in a shock hazard that could cause severe injury or death.**

## 5.3 SPECIAL HANDLING OF STATIC SENSITIVE DEVICES

MOS devices are designed to function at high impedance levels. Normal static charge can destroy these devices. Table 5-1 lists all the static sensitive devices for the Model 1753. Steps 1 through 7 provide instructions on how to avoid damaging these devices.

1. Devices should be handled and transported in protective containers, antistatic tubes or conductive foam.
2. Use a properly grounded work bench and a grounding wriststrap.
3. Handle device by the body only.
4. PCBs must be grounded to bench while inserting devices.
5. Use antistatic solder suckers.
6. Use grounded tip soldering irons.
7. After devices are soldered or inserted into sockets they are protected and normal handling can resume.

Table 5-1. Static Sensitive Devices

| Circuit Designation | Keithley Part Number |
|---------------------|----------------------|
| U101                | LSI-60               |
| U102                | LSI-30               |
| U103                | IC-338               |
| U106, U110          | IC-106               |
| U108                | IC-341               |

## 5.4 TROUBLESHOOTING

The troubleshooting information in this section is intended for use by qualified personnel who have a basic understanding of the analog and digital circuitry used in a precision test instrument. Instructions have been written to assist in isolating the defective circuit. Isolating the defective component has been left up to the troubleshooter. Refer to Table 5-2 for IEEE-488 interface board checks.

### NOTE

For instruments that are still under warranty (less than 12 months since date of shipment), whose performance falls outside specification at any point, contact your Keithley representative or the factory before attempting troubleshooting or repair.

**Table 5-2. Model 1753 IEEE-488 Interface Checks**

| Step | Item/Component                 | Required Condition  | Remarks                             |
|------|--------------------------------|---|-------------------------------------|
| 1    | J1008 pin 1 reference to pin 2 | +5V $\pm$ 10% referenced to Digital Common                                | +5V Digital Supply                  |
| 2    | S401 (1-6)                     | In the "1" position the switch is pulled up to +5V $\pm$ 10%              | Primary Address                     |
| 3    | U404 pin 18                    | 1MHz square wave at 0V to +5V   | Clock to U404                       |
| 4    | U404 pin 9                     | +5V signal being pulsed to 0V every 1msec                                 | IRQ Line                            |
| 5    | U404 pin 19                    | +5V (logic "1")<br>Program the Model 175 into Remote (primary address 24) | RESET Line                          |
| 6    | U405 pins 19 and 2 (D1 and B1) | Logic "1" ( $\approx$ +5V)  | Information across bus transceiver. |
| 7    | U405 pins 18 and 3 (D2 and B2) | Logic "1" ( $\approx$ +5V)  | Information across bus transceiver. |
| 8    | U405 pins 17 and 4 (D3 and B3) | Logic "0" ( $\approx$ 0V)   | Information across bus transceiver. |
| 9    | U405 pins 16 and 5 (D4 and B4) | Logic "0" ( $\approx$ 0V)   | Information across bus transceiver. |
| 10   | U405 pins 15 and 6 (D5 and B5) | Logic "1" ( $\approx$ +5V)  | Information across bus transceiver. |
| 11   | U405 pins 14 and 7 (D6 and B6) | Logic "0" ( $\approx$ 0V)   | Information across bus transceiver. |
| 12   | U405 pins 13 and 8 (D7 and B7) | Logic "1" ( $\approx$ +5V)  | Information across bus transceiver. |
| 13   | U405 pins 12 and 9 (D8 and B8) | Logic "1" ( $\approx$ +5V)  | Information across bus transceiver. |

**NOTE**

All measurements in Table 5-2 are referenced to digital common.

## **SECTION 6 REPLACEABLE PARTS**

### **6.1 INTRODUCTION**

This section contains replacement parts information, schematic diagrams and component location drawings for the Model 1753.

### **6.2 PARTS LIST**

The electrical parts are listed in Table 6-1 in alphabetical order of their circuit designations. Figure 6-1 shows the pertinent mechanical parts.

### **6.3 ORDERING INFORMATION**

To place an order, or to obtain information concerning replacement parts, contact your Keithley representative or the factory. See the inside front cover for addresses. When ordering include the following information:

1. Instrument Model Number
2. Instrument Serial Number

3. Part Description
4. Circuit Description (if applicable)
5. Keithley Part Number

### **6.4 FACTORY SERVICE**

If the instrument is to be returned to the factory for service, please complete the service form which follows this section and return it with the instrument.

### **6.5 SCHEMATIC DIAGRAM AND COMPONENT LOCATION DRAWING**

A Schematic diagram and component location drawing follows the replaceable parts list information contained in this section. The drawings are listed as follows:

Figure 6-2 - Component Location Drawing for the Model 1753

Figure 6-3 - Schematic Diagram for the Model 1753

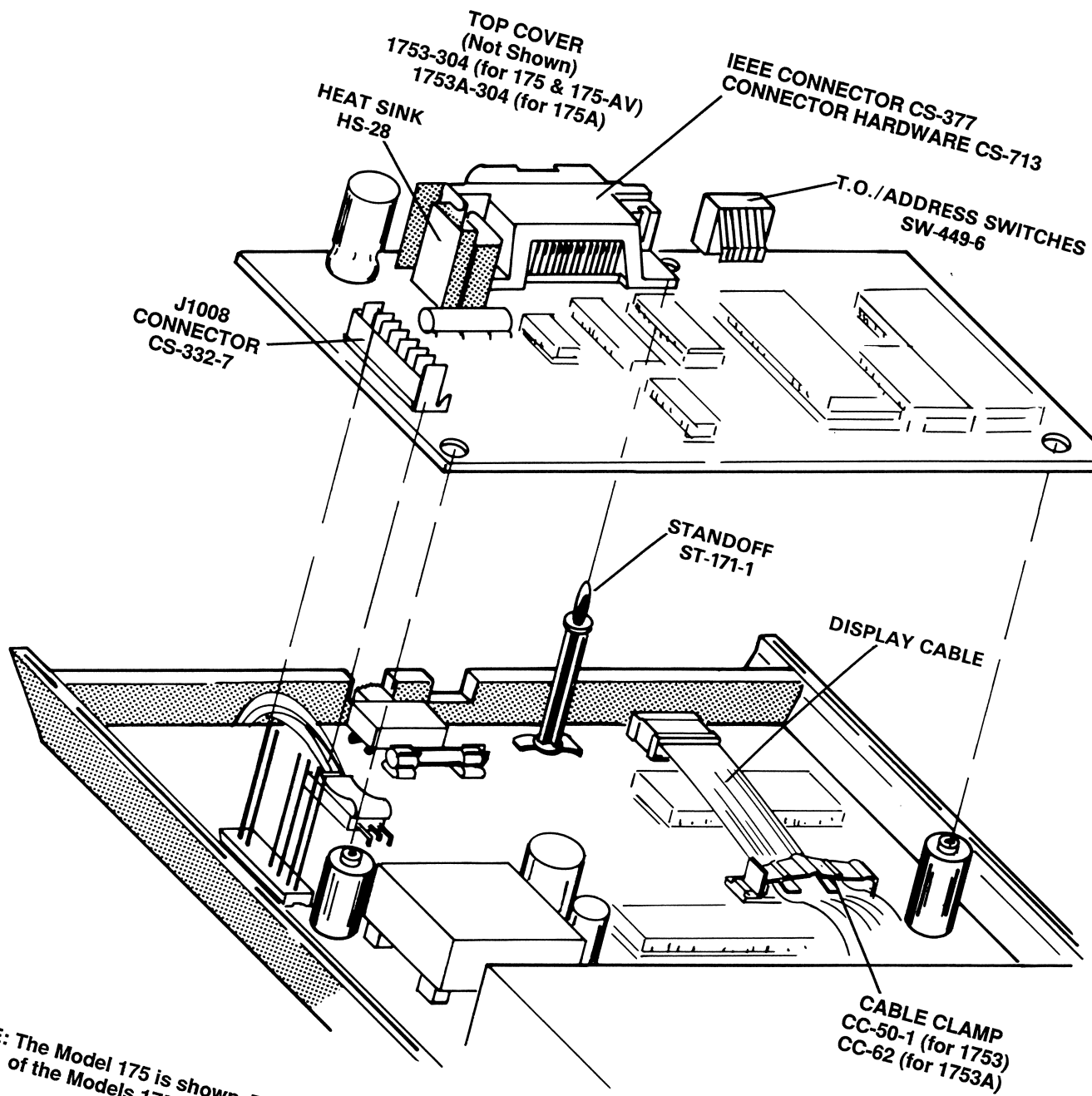

NOTE: The Model 175 is shown. The rear panel and mother board of the Models 175A and 175-AV differ slightly.

Figure 6-1. Model 1753/1753A Installation

**Table 6-1. Model 1753/1753A, Parts List**

| Circuit Desig. | Description                                     | Location |     | Keithley Part No. |
|----------------|---|----------|-----|-------------------|
|                |   | Pcb      | Sch |                   |
| C101           | Capacitor, 22pF, 500VDC, Ceramic Disc           | C2       | B3  | C-22-22p          |
| C102           | Capacitor, 22pF, 500VDC, Ceramic Disc           | C2       | B3  | C-22-22p          |
| C103           | Capacitor, 4.7μF, 25VDC, Aluminum Electrolytic  | C3       | D2  | C-314-4.7         |
| C104           | Capacitor, .01μF, 16VDC, Ceramic Disc           | C3       | B2  | C-238-.01         |
| C105           | Capacitor, .01μF, 16VDC, Ceramic Disc           | D2       | E1  | C-238-.01         |
| C106           | Capacitor, .01μF, 16VDC, Ceramic Disc           | D3       | F1  | C-238-.01         |
| C107           | Capacitor, .01μF, 16VDC, Ceramic Disc           | E3       | G3  | C-238-.01         |
| C108           | Capacitor, .1μF, 16VDC, Ceramic Disc            | F3       | C5  | C-238-.1          |
| C109           | Capacitor, 2200μF, 16VDC, Aluminum Electrolytic | F3       | C5  | C-351-2200        |
| CR101          | Rectifier, 1N914                                | C3       | D2  | RF-28             |
| CR102          | Rectifier, Bridge, VM18                         | F3       | C5  | RF-52             |
| J1007          | IEEE Connector                                  | E3       | H3  | CS-377            |
| J1008          | Molex Connector (7 pin)                         | F2       | E5  | CS-332-7          |
| K101           | Relay, Single Pole                              | E2       | D5  | RL-83             |
| R101           | Resistor, 10MΩ, 5%, 1/4W, Composition           | C2       | B3  | R-76-10M          |
| R102           | Resistor, 3.3kΩ, 5%, 1/4W, Composition          | C3       | D2  | R-76-3.3k         |
| R103           | Resistor, 3.3kΩ, 5%, 1/4W, Composition          | C3       | D3  | R-76-3.3k         |
| R104           | Thick Film Resistor Network                     | C3       | B1  | TF-99             |
| R105           | Resistor, 330Ω, 5%, 1/4W, Composition           | E2       | D6  | R-76-330          |
| R106           | Resistor, 10kΩ, 5%, 1/4W, Composition           | E2       | D5  | R-76-10k          |
| R107           | Resistor, 100kΩ, 5%, 1/4W, Composition          | E2       | D5  | R-76-100k         |
| R108           | Resistor, 10kΩ, 5%, 1/4W, Composition           | F2       | D5  | R-76-10k          |
| R109           | Resistor, 100kΩ, 5%, 1/4W, Composition          | F2       | D6  | R-76-100k         |
| R110           | Resistor, 330Ω, 5%, 1/4W, Composition           | F2       | D5  | R-76-330          |
| S101           | Primary Address Switches, Bank of 6 switches    | D3       | A2  | SW-449-6          |
| U101           | Microprocessor, 6805E2                          | C2       | B3  | LSI-60            |
| U102           | EPROM, 2732                                     | D2       | E2  | 1753-800-**       |
| U103           | Octal D Latch, 74HC373                          | D3       | E3  | IC-338            |
| U104           | GPIO Adapter, 9914                              | D2       | F2  | LSI-49            |
| U105           | GPIO Transceiver, 75161                         | E2       | G3  | IC-299            |
| U106           | Hex Inverter, 4049                              | E2       | SEV | IC-106            |
| U107           | GPIO Transceiver, 75160                         | E3       | G2  | IC-298            |
| U108           | 3-Input NAND GATE 74HC10                        | E3       | SEV | IC-341            |
| U109           | Opto Isolator, TIL117                           | E2       | D5  | IC-362            |
| U110           | Hex Inverter, 4049                              | F2       | SEV | IC-106            |
| U111           | Opto Isolator, TIL117                           | F2       | D6  | IC-362            |
| VR101          | +5V Voltage Regulator, 7805CP5                  | E3       | C5  | IC-93             |
| Y101           | Crystal, 4.0MHz                                 | C2       | B3  | CR-10             |
| —              | Top Cover, Modified (brown)                     |          |     | 1753-304          |
| —              | Standoff (IEEE to Mother board)                 |          |     | ST-171-1          |
| —              | Heat Sink (used on VR101)                       |          |     | HS-28             |
| —              | Top Cover, Modified (gray)                      |          |     | 1753A-304         |
| —              | Socket (for U102)                               |          |     | SO-68             |
| —              | 40-pin socket (for U101)                        |          |     | SO-84-40          |

\*\*When ordering, specify software level of Model 175.

