

4114 COMPUTER DISPLAY TERMINAL

*Please Check for
CHANGE INFORMATION
at the Rear of this Manual*

First Printing AUG 1982

Tektronix[®]
COMMITTED TO EXCELLENCE

WARNING

THE FOLLOWING SERVICING INSTRUCTIONS ARE FOR USE BY QUALIFIED PERSONNEL ONLY. TO AVOID PERSONAL INJURY, DO NOT PERFORM ANY SERVICING OTHER THAN THAT CONTAINED IN OPERATING INSTRUCTIONS UNLESS YOU ARE QUALIFIED TO DO SO.

Copyright © 1982 by Tektronix, Inc., Beaverton, Oregon.
Printed in the United States of America. All rights reserved.
Contents of this publication may not be reproduced in any form without permission of Tektronix, Inc.

This instrument, in whole or in part, may be protected by one or more U.S. or foreign patents or patent applications. Information provided on request by Tektronix, Inc., P.O. Box 500, Beaverton, Oregon 97077.

TEKTRONIX is a registered trademark of Tektronix, Inc.

MANUAL REVISION STATUS

PRODUCT: 4114 Computer Display Terminal

This manual supports the following versions of this product: Serial Numbers B010100 and up.

REV DATE	DESCRIPTION
AUG 1982	Original Issue; replaces 061-2489-00.

CONTENTS

Section 1	INTRODUCTION	Page
	Related Documents	1-1
	General Description	1-1
	Physical Description	1-2
	Options	1-4
	Accessories	1-5
Section 2	INSTALLATION	
	Introduction	2-1
	Selecting an Installation Site	2-1
	Unpacking the Terminal	2-3
	Checking the Operating Voltage	2-4
	Connecting Cables and Applying Power	2-4
	Testing the Terminal (Self-Test)	2-5
	Connecting to a Host Computer	2-5
	Telephone Line Connection	2-5
	Testing Communication	2-6
	Packaging for Shipment	2-6
Section 3	STRAP INFORMATION	
	Introduction	3-1
	Pedestal Inverter Board	3-2
	Processor Board Straps	3-3
	Keyboard Straps	3-4
	RAM/ROM and RAM Controller Board Straps	3-4
	Display Module Straps	3-6
	X and Y Input Interchange (Deflection Amplifier Board)	3-7
	Selecting Hold IN/OUT (Deflection Amplifier Board)	3-7
	Selecting Antiburn IN/OUT (Deflection Amplifier Board)	3-7
	Selecting FAST/SLO (Deflection Amplifier Board)	3-7
	Selecting N/TEST (Storage Board)	3-7
	Selecting Z Reset Select (Storage Board)	3-7
	Selecting Z Axis Input Polarity (HV & Z Axis Board)	3-7
	Selecting Line Operating Voltage	3-8
	Vector Generator Board Straps	3-9
	Display Controller Board Straps	3-9

Section 4	ABBREVIATED ADJUSTMENT PROCEDURE	
	Introduction	4-1
	Pedestal Adjustment	4-1
	Display Adjustment	4-4
Section 5	SELF-TEST DIAGNOSTIC PROGRAM	
	Introduction	5-1
	Parts of Self-Test	5-1
	Control Flow of Self-Test	5-2
	Self-Test Firmware Jump Table	5-5
	How to Run Self-Test	5-5
	Self-Test Error Messages	5-6
	Errors Directory	5-6
	Keyboard Check and Lights	5-6
	Processor Check	5-10
	Communications and Bus Checks	5-14
	Memory Tests	5-18
	Display Tests (9)	5-23
	System Level Errors (7x)	5-29
	4114 Option Tests and Error Messages	5-31
	3PPI Board Tests	5-31
	Adjustment Self-Test	5-44
	The General Menu	5-45
	Display Menu	5-45
	Processor Board Menu	5-46
	Disk Option Menu	5-47
	Tablet Adjustment Menu/Procedure	5-48
Section 6	REPLACEABLE ELECTRICAL PARTS	
Section 7	INTERCONNECT AND BLOCK DIAGRAMS	
Section 8	SCHEMATICS	
Section 9	REPLACEABLE MECHANICAL PARTS	
Appendix A	SIGNAL LIST	
Appendix B	ASCII CODE AND KEYCODE CHARTS	

ILLUSTRATIONS

Figure	Description	Page
1-1	The 4114 Computer Display Terminal	vi
1-2	4114 Motherboard	1-3
2-1	4114 Dimensions	2-2
2-2	Power, RS-232, and Display Cables	2-4
2-3	Display Module Packaging Configuration	2-7
2-4	Accessory Box Packaging Configuration	2-8
2-5	Pedestal Packaging Configuration	2-9
3-1	Power Supply Inverter Board; AC Input Jumper in 115 Vac Position	3-2
3-2	RAM Controller Board Base Address Strap Positions	3-5
3-3	Five Terminal Barrier Strip Wiring and Jumper Positions for Line Voltage Selection	3-8
4-1	INIT Waveform	4-2
4-2	PDWN-INIT Signal	4-2
4-3	PFAIL Waveform	4-2
4-4	Charge Pump Waveform	4-3
4-5	Adjusted Charge Pump Waveform	4-3
4-6	Target Erase Waveform	4-5
4-7	Target Erase Waveform Enlarged	4-5
4-8	Target Erase Pulse Waveform	4-5
4-9	CE-2 Waveform	4-6
4-10	CE-1 Waveform	4-6
4-11	Flood Gun Anode Waveform	4-7
4-12	Waveform at R246	4-7
4-13	X and Y Axis Frequency Compensation Adjustments	4-8
4-14	Dynamic Focus Waveform	4-9
4-15	Brite Intensity Pulse	4-9
4-16	Display Controller Board-A8	4-11
4-17	Vector Generator Board-A9	4-11
4-18	High Voltage and Z Axis Board-A16A1	4-13
4-19	Double Erase Storage Board-A13A1	4-13
4-20	Low Voltage Power Supply Board-A12	4-15
4-21	Deflection Amplifier Board-A15A1	4-15
5-1	Self-Test Functional Diagram	5-1
5-2	Self-Test Program Block Diagram	5-2
5-3	The ROM Header contains a Chain of Pointers to Testing and Adjustment routines that are executed via Jump Tables	5-5
5-4	RAM/ROM Board	5-9
5-5	Processor Board ROMs	5-13
5-6	Status Byte	5-16
5-7	4114 Self-Test Control Flow	5-49

TABLES

Table	Description	Page
2-1	Packaging Configurations	2-6
3-1	Processor Board Strap Settings.....	3-3
3-2	Keyboard Language Option Straps	3-4
3-3	Display Module Straps	3-6
3-4	Fuse Selection	3-8
4-1	LVPS Voltage Tolerances and Ripple.....	4-4
5-1	Power-Up/Self-Test Sequence.....	5-3
5-2	Self-Test Errors Directory	5-7
5-3	Keyboard/Processor Board Errors	5-8
5-4	Processor Board Errors.....	5-10
5-5	RAM/Bus and Host Port Errors	5-14
5-6	Hex-to-Decimal Equivalents	5-17
5-7	System/Option ROMs Errors.....	5-18
5-8	RAM Test Errors	5-20
5-9	CMOS Memory Errors	5-22
5-10	Display Controller, Vector Generator, and Display Module Errors.....	5-23
5-11	System Level (7x) Error Codes.....	5-29
5-12	3PPI Errors	5-31
5-13	Disk Option Errors	5-33
5-14	Tablet Error Messages	5-41
5-15	Adjustment Control Keys	5-44
B-1	ASCII (ISO-7-US) Code Chart.....	B-1
B-2	Characters Used in < Char> Parameters.....	B-2
B-3	Characters Used in < Int> and < Int+ > Parameters.....	B-3
B-4	Characters Used in < Int-Report> Parameters.....	B-4
B-5	Characters Used in < Xy> Parameters	B-5
B-6	Characters Used in < Xy-Report> Parameters.....	B-6
B-7	United Kingdom Character Set.....	B-7
B-8	Swedish Character Set	B-8
B-9	APL Character Set	B-9
B-10	Danish/Norwegian Character Set	B-10
B-11	Keyboard/Keycodes.....	B-11

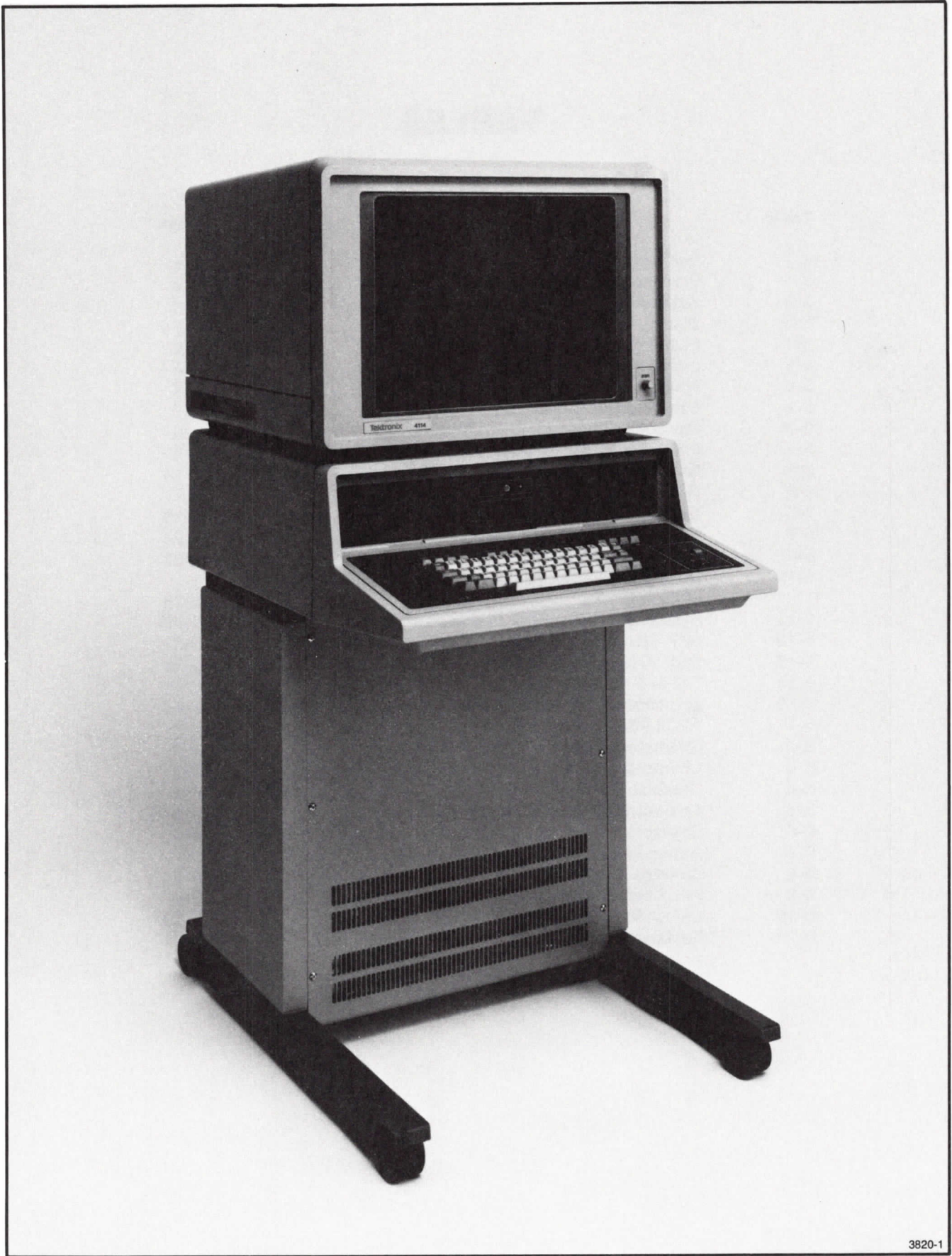

3820-1

Figure 1-1. The 4114 Computer Display Terminal.

Section 1

INTRODUCTION

The 4114 Computer Display Terminal Service Manual is divided into two volumes. Volume 1 includes introductory information, operating information, circuit theory, functional check and performance check procedures, a detailed description of the adjustment procedure, troubleshooting and self test diagnostic, and maintenance information. Volume 1 is primarily a reference manual. Volume 2, on the other hand,

contains frequently used information that the service technician needs to troubleshoot, repair, and adjust the terminal in the field. This information includes an abbreviated adjustment procedure, electrical and mechanical parts lists, block and schematic diagrams, installation information, and the Self Test diagnostic program, which is a built-in, firmware troubleshooting aid.

RELATED DOCUMENTS

Detailed information on the use of the 4114 terminal is found in the following documents.

- 4114 Computer Display Terminal Operator's Manual
- 4114 Host Programmer's Manual
- 4110 Series Command Reference Manual
- 4114 Introduction Brochure

GENERAL DESCRIPTION

The 4114 is a high-resolution, microprocessor-controlled graphics computer terminal. The display is a 19-inch diagonal direct view storage tube. More than 12 million points on the display surface are individually addressable. By using these points, the display presents a graphic image made up of line segments. This image is displayed in either of two modes: Storage mode or Refresh mode. In Storage mode, the image is stable and permanent on the screen until it is erased. In Refresh mode, the image is continuously renewed, and therefore is easily moved around the screen surface. Graphics images can be constructed using both modes at the same time.

The 4114 uses microprocessor technology to create more than 100 primarily graphics-related commands. Using these commands, a host-resident software program run on a 4114 can create graphic images that can be displayed, modified, and sent to and received from a host computer. The 4114 carries most of the graphics processing-time burden if its local graphics commands are used.

The standard 4114 contains 32 K of RAM (read/write) memory and can contain up to 800 K of RAM memory on optional RAM Controller boards. As much as one megabyte of words can be stored on the optional flexible disks — 512 K bytes per disk. The maximum host computer communication speed ("baud rate") is 19,200 bits per second for graphics and 38.4 K bits per second for text.

Set-Up mode uses English-language type commands to initialize many terminal operating parameters. Three of the major classifications are: general, dialog, and communications. In the general group, parameters like margin, echo, and Snoopy mode are set. In the dialog group, parameters like buffer size, line width, and number of lines are set. And in the communications group, parameters such as number of stopbits, kind of parity, and end-of-line string are set.

INTRODUCTION

Most commands for the 4114 are encoded as three character ASCII codes beginning with the ESC character. The host computer controls the 4114 by sending it these three character ESC sequences in the order determined by each specific job to be done. (The Set-Up mode commands are encoded both as English-language type commands and as ESC sequences.)

Many features of the 4014 Computer Display Terminal are emulated by the 4114 terminal. Because of this, most application programs written for the 4014 run on the 4114 with very little or no modification. In addition, most peripheral devices that function connected to the 4014 also function when they are connected to the 4114. This includes Tektronix hard copy units and plotters.

PHYSICAL DESCRIPTION

The 4114 consists of two main parts: the display module and the pedestal. The display module sits on four plastic bumpers (feet) on top of the pedestal. After the terminal is installed, the display module and pedestal are connected by two cables — the AC Display power cable and the display cable.

The display module contains a 19-inch direct view storage tube. The mechanical package is similar to the Tektronix 618 Display Monitor. The display electronics inside the display module include high voltage and Z axis, storage, deflection amplifier, hard copy amplifier, and low voltage power supply circuitry. This circuitry is similar to that in the Tektronix GMA102A Display Monitor.

The pedestal consists of the keyboard, the low voltage power supply, the card cage, and six mounting plates on the rear panel.

The keyboard has a standard typewriter-like layout of ASCII-encoded keys. There are eight programmable and four command keys along with four LED indicator lights situated above the standard ASCII keys. There are also two thumbwheels — one moving up and down (controlling vertical motion on the screen) and one moving across (controlling horizontal motion on the screen).

Above the keyboard is the power switch. Optional flexible disk assemblies may be installed on one or both sides of the power switch.

The card cage and low voltage power supply are found inside the pedestal below the keyboard. The card cage contains plug-in circuit boards with dimensions of 8.5 by 11.5 inches.

The standard 4114 contains the following circuit boards:

- Motherboard. This has slots for five standard size circuit boards. The 80 pin bus of the Motherboard is the System Bus.
- Processor board.
- RAM/ROM board. This contains system EPROM and one 32 K RAM Array board.
- Display Controller board.
- Vector Generator board.

Figure 1-2 shows the Motherboard card slot locations and priority. If two or more bus masters are contending for control of the bus, it is necessary to assign a "bus priority" to each of the bus masters. This is done by inserting the board with highest priority in Motherboard slot connector J1, the next highest priority board in J2, etc. Since the Disk Controller Board requires the highest priority for DMA operations, it is always inserted in J1. The Processor Board goes in J2, and the Display Controller Board in J4.

Note that the above placement of boards in the Motherboard yields the highest possible priority for each board. A board placement that preserves the relative priorities of the boards, for example, is the following: Disk Controller in J3, Processor Board in J4, and Display Controller in J5. The boards operate properly when given relative priority position.

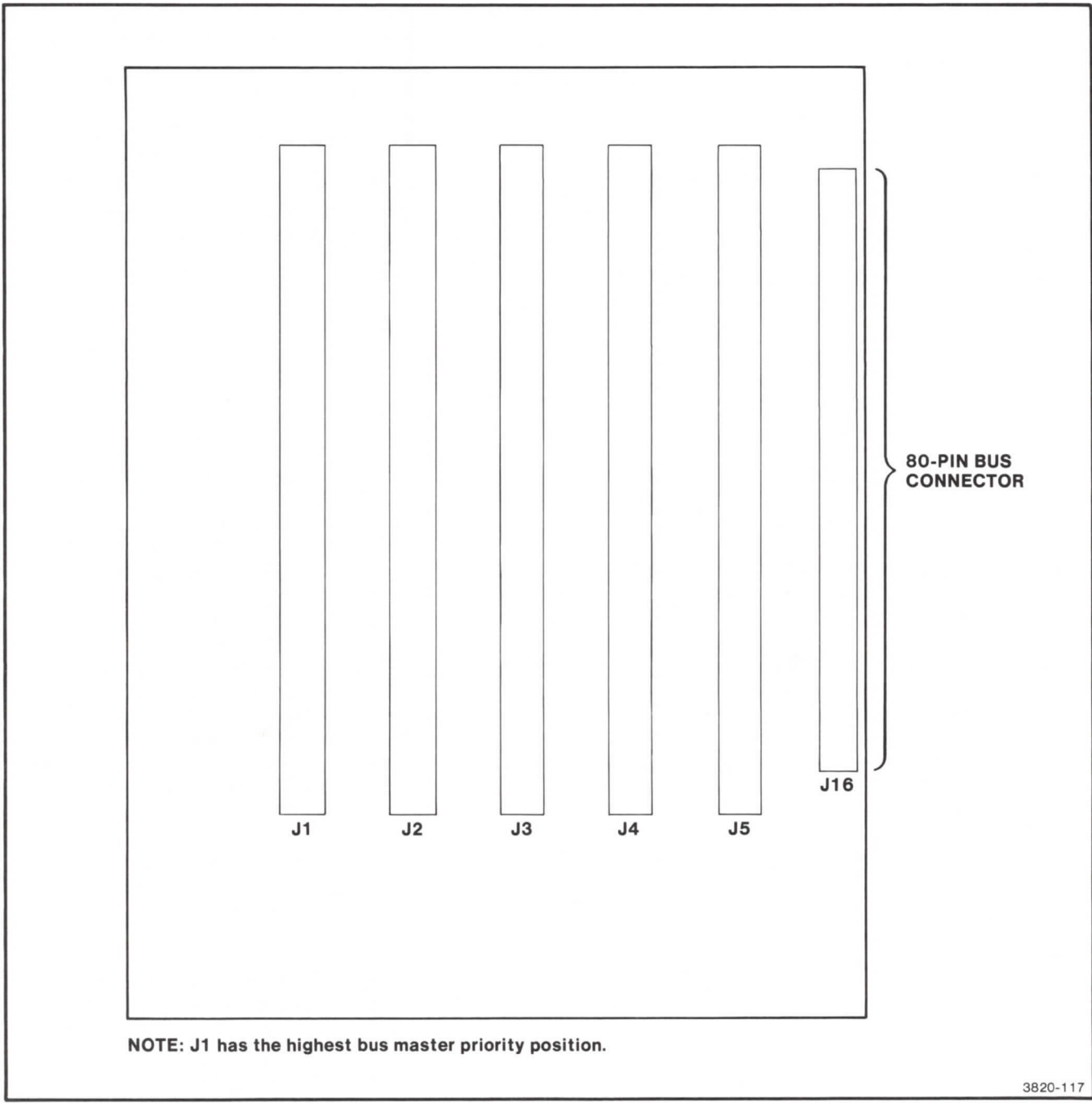

Figure 1-2. 4114 Motherboard.

INTRODUCTION

The 4114 may contain these optional circuit boards:

- Motherboard Extender. This increases the System Bus slots of the Motherboard to fifteen total slots. (Option 40 or 41)
- Three Port Peripheral Interface (3PPI) board. (Option 10)
- Tablet Controller board. (Part of Option 13 and 14)
- Disk Controller board. (Part of Option 42 and 43)

The low voltage power supply provides all the operating voltages for the Pedestal circuitry and is located above and to the right of the card cage — looking at the card cage from the front.

There are six removable mounting plates on the rear panel of the pedestal. One is standard and five hold optional connectors or L-brackets. The standard RS-232 host computer connector is mounted to the standard plate. The display cable connector is mounted here also.

OPTIONS

The following list of options is arranged in numerical order. Option numbers beginning with a letter designation are placed at the end of the list.

- Option 1 Extended Communications (includes half-duplex, block mode, and downloader).
- Option 2 Current Loop Interface (see Current Loop Interface Service Manual for detailed service information).
- Option 4A United Kingdom Keyboard. Hardware is identical to standard keyboard, except for keyboard ROMs.
- Option 4C Swedish Keyboard. Same hardware as other keyboards.
- Option 4E APL Keyboard. Same hardware as other keyboards.
- Option 4F Danish and Norwegian Keyboard. Same hardware as other keyboards.
- Option 10 Three Port Peripheral Interface (3PPI). This option supports the following peripheral devices:
- 4662 and 4663 Plotters
 - 4641 and 4642 Printers
 - 4923 Tape Recorder with Option 1 installed and other RS-232 devices
- See the 4110 Series Option 10 3PPI Service and 4114 Operator's Manuals for details.

- Option 13 Graphic Tablet. Size: 11 by 11-inches. Option hardware includes: Graphic Tablet (and pen), 411X Tablet Controller board, and Tablet Interface board. See the 4110 Series F13/14 Graphics Tablet Instruction and 4114 Operator's Manuals.
- Option 14 Graphic Tablet. Size: 30 x 40-inch. Option hardware includes: Graphic Tablet (and pen), 411X Tabet Contoller board, and Tablet Interface board. See the 4110 Series F13/14 Graphics Tablet Instruction and 4114 Operator's manuals.
- Option 24 One RAM Controller Board. Includes 32 K bytes of RAM on one RAM Array Board. Service information is in Appendix B of this manual.
- Option 25 One RAM Controller Board. Includes 64 K bytes of RAM on two RAM Array Boards. For service information, see Opt. 24.
- Option 26 One RAM Controller Board. Includes 96 K bytes of RAM on three RAM Array Boards. For service information, see Opt. 24.
- Option 27 One RAM Controller Board. Includes 128 K bytes of RAM on four RAM Array Boards. For service information, see Opt. 24.

- | | | | |
|-----------|---|-----------|---|
| Option 28 | Two RAM Controller Boards. Includes 256 K bytes of RAM on eight RAM Array Boards. For service information, see Opt. 24. | Option 43 | Dual Flexible Disk Drives and one Disk Controller board. The service information is located in the Option 42/43 Service Manual, and 119-0977-01/03 Drive Unit Service Manual. |
| Option 29 | Four RAM Controller Boards. Includes 512 K bytes of RAM on sixteen RAM Array Boards. For service information, see Opt. 24. | Option 52 | Customer-specified line voltage and frequency option. |
| Option 30 | Local Easy Graphing. | Option A1 | Universal European line voltage and frequency: 220 V, 50 Hz. |
| Option 31 | Color Enhanced Refresh. Display Module has special DVST that writes refreshed vectors in yellow-orange. | Option A2 | United Kingdom line voltage and frequency: 240 V, 50 Hz. |
| Option 40 | Ten-Slot Peripheral Bus Extender. Includes Motherboard Extender, wire kit, and two 7 watt fans. | Option A3 | Australian line voltage and frequency: 240 V, 50 Hz. |
| Option 41 | Same as Option 40 except 14 W fans for Japan. | Option A4 | North American line voltage and frequency: 240 V, 60 Hz. |
| Option 42 | Single Flexible Disk Drive, and one Disk Controller board. The service information is located in the Option 42/43 Service Manual, and 119-0977-01/03 Drive Unit Service Manual. | Option A5 | Switzerland line voltage and frequency: 220 V/10 A, 50 Hz. |

ACCESSORIES

This list is divided into two parts: the standard accessories that are supplied with each 4114, and those accessories that may be ordered separately in addition to the standard accessories. The following accessories are also found in the parts list, where part numbers are listed for each item.

Standard Accessories:

- 4114 Computer Display Terminal Operator's Manual
- 4110 Series Command Reference Manual
- Power cord set
- Host Port RS-232 cable
- Eight relegendable key caps
- Six function key overlays
- 4114 Host Programmer's Manual
- 4114 Introduction Brochure

Optional Accessories:

- Relegendable key caps
- Function key overlays
- 4114 Service Manual, Volume 1
- 4114 Service Manual, Volume 2
- 4110 Series Option 10 Three Port Peripheral Interface (3PPI) Manual
- 4110 Series Option 13/14 Graphics Tablet Manual
- 4110 Series Option 42/43 Disk Drives Manual
- 119-0977-01/03 Flexible Disk Drive Instruction Manual
- RS-232 Loopback Connector
- Current Loop Loopback Connector

Section 2

INSTALLATION

INTRODUCTION

WARNING

Dangerous voltages exist within the terminal. Use normal electrical precautions when working inside the terminal.

Installation consists of locating a suitable installation site, unpacking the terminal, checking operating voltages, applying power, testing the internal operation with Self Test, connecting the terminal to a host computer, and testing communication between the host computer and the terminal.

The terminal is packaged as two units: the pedestal and the display module. Once these are unpacked, the display module is placed on the pedestal and the power, display, and RS-232 communication cables are connected. No further assembly is required. However, if new options are to be installed, disassembly of the terminal may be required. **THIS SHOULD BE DONE BY QUALIFIED SERVICE TECHNICIANS ONLY.**

SELECTING AN INSTALLATION SITE

The primary requirement for proper operation is adequate ventilation clearance around the terminal. Make sure, especially, that the heat sink at the back of the terminal has at least two inches (5.08 cm) clearance from the nearest wall or surface. More clearance provides better ventilation and greater reliability. The terminal consumes a maximum of about 800 watts (2720 BTU/hour). Typical consumption is about 500 watts (1700 BTU/hour).

Temperature should be within the range of + 10 to + 40 C (50 to 104 F) without the flexible disk drive(s) option (Option 42/43) and + 10 to + 36 C (50 to 97 F) with the option. Relative humidity should be a maximum of 75% without Option 42/43 and within the range of 20% to 75% with Option 42/43.

Use Figure 2-1, 4114 Dimensions, to determine how much space is required for the terminal.

INSTALLATION

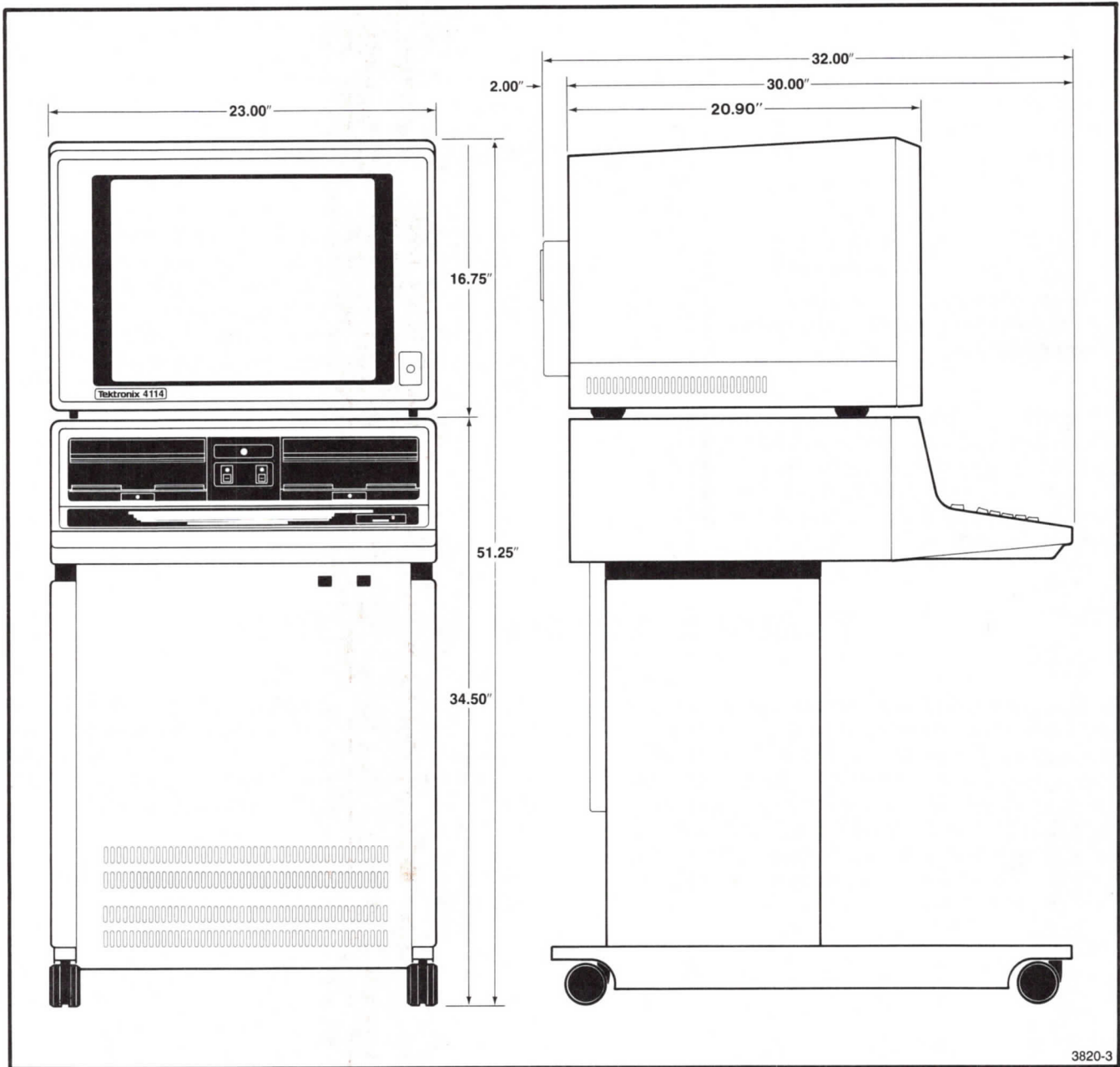

Figure 2-1. 4114 Dimensions.

UNPACKING THE TERMINAL

The terminal is shipped in two cartons. The small carton contains the display module plus packing material. The large carton contains the pedestal, the ordered accessories, and some packing materials.

WARNING

Both shipping cartons are HEAVY. Two people should do the lifting necessary to install the terminal. Please use proper lifting techniques to avoid injury to yourselves or the terminal.

Before opening the cartons, gather these tools: a medium-size flat-bladed screwdriver, a carton opener (a small stout-bladed knife), and a medium-size — about two feet long — crowbar (pinch bar).

During the unpacking procedure, check the packing list against the terminal, accessories, and any options also ordered to make sure that they agree. Refer to the following lists.

Standard accessories included with the 4114 are:

- 4114 Computer Display Terminal Operator's Manual
- 4110 Series Command Reference Manual
- Power cord set
- Host Port RS-232 cable
- Eight relegendable key caps
- Six function key overlays
- 4114 Host Programmer's Manual
- 4114 Introduction Brochure

Optional Accessories:

- Relegendable key caps
- Function key overlays
- 4114 Service Manual Volume 1
- 4114 Service Manual Volume 2
- 4110 Series Option 10 Three Port Peripheral Interface (3PPI) Manual
- 4110 Series Option 13/14 Graphic Tablets Manual
- 4110 Series Option 42/43 Flexible Disk Drives Manual
- 119-0977-00 Flexible Disk Drive Instruction Manual
- RS-232 Loopback Connector
- Current Loop Loopback Connector

Before beginning the unpacking procedure, carefully inspect both shipping cartons for any signs of damage. Report any damage to the carrier and the local Tektronix sales representative immediately.

1. Use the carton opener to cut the plastic straps on the pedestal carton. Lift the carton straight up and over the pedestal. Note that the packages containing the standard accessories are placed on top of the packing material protecting the top of the terminal. Look in the carton for these packages if they are not seen immediately on top of the terminal. Remove any packing material from the top of the terminal.
2. The pedestal is secured to the shipping pallet by two boards that are power-stapled over the roller legs both in front and in back of the lower portion of the pedestal. Use the crowbar to pry both boards loose from the pallet structure.

WARNING

The sharp ends of the staples in the two boards need to be placed a safe distance away from all foot traffic.

3. Lift the pedestal off the pallet and set it down. Remove the pallet from the immediate area.
4. Lift the display module carton onto a table or other suitable surface near the pedestal.
5. Open the top of the carton with the carton opener and remove the packing material. Slit the carton at three of its vertical edges; then remove the display module from the carton and set it on the pedestal top. (Save the shipping cartons and packaging material in case the terminal needs to be shipped again. See Packaging For Shipment at the end of this section.)

CHECKING THE OPERATING VOLTAGE

CAUTION

If the terminal is not set for the proper operating voltage, and the terminal is connected to a voltage different from what it is set for, serious damage to the terminal may occur.

The terminal has two yellow voltage indicators that should be checked to see that the terminal is set to the proper ac power supply for the site. Make sure that the indicator on the pedestal and the one on the display module both are set to show the same value and that the value is correct. These yellow indicators are located on the back of each unit near the ac power receptacles. (Note that changing the yellow indicator does not change the internal voltage settings.)

CAUTION

Installation of new options and changing the operating voltages for the 4114 should be done by qualified service personnel only. Procedures for changing the operating voltage are located in the Maintenance section of the 4114 Service Manual Volume 1. Procedures for installing options are found in Volume 1 of this manual or the manual describing the option.

CONNECTING CABLES AND APPLYING POWER

There are two cables connecting the pedestal and display module — the ac power cable and the display cable. In addition, the pedestal has its ac power cable connecting it to a power outlet and its RS-232 communication cable connecting it to a modem or directly to the host computer. The 4114 should be operated only with all of these cables properly connected.

1. Refer to Figure 2-2 and attach the display cable to the pedestal. Tighten alternately the screws on either side of the cord. Use a small, flat-bladed screwdriver to tighten the screws.
2. Attach the host port RS-232 cable to the modem and pedestal. Use the screwdriver to secure the connectors.
3. Make sure the power button on the front is in the OFF position. Then plug the AC display power cable into the pedestal and the display module. Connect the AC power cable to the pedestal and an ac power outlet.
4. Push in the power button. Wait a few minutes until the keyboard LEDs all go off. The cursor should appear in the upper left corner of the screen. If it does not appear, refer to the Self Test section.

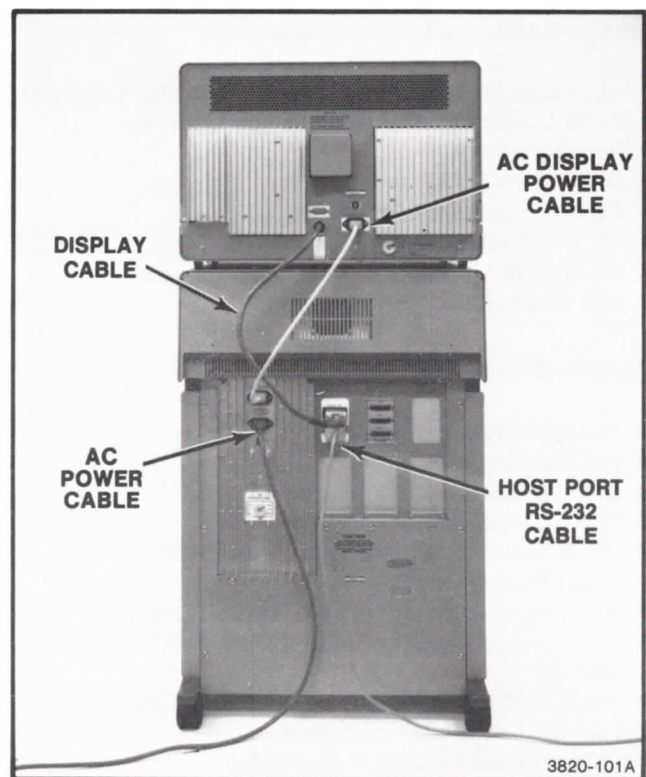

Figure 2-2. Power, RS-232, and Display Cables.

TESTING THE TERMINAL (SELF TEST)

NOTE

More about Self Test is found in Section 5 of this manual. The following procedures are just for verification of correct operation of the terminal. If the terminal fails to pass one of the two versions of Self Test, a malfunction code stays lit on the keyboard LED lights. To decode the malfunction, consult Self Test in Section 5.

When the terminal is turned on, it runs through a power-up, Self Test routine. This routine tests about 30% of the circuitry in the terminal. If a malfunction is found during the power-up routine, a malfunction message appears on the eight keyboard LEDs. The LED light patterns are interpreted as a two digit hexadecimal number. The righthand four LEDs (bits) form the least significant hexadecimal digit, and the lefthand four LEDs (bits) form the most significant hexadecimal digit. For first time operation, a more detailed version of Self Test should be run. A brief outline of how to perform this test follows. Refer to Section 5 of this manual for more information.

1. Apply power to the terminal.
2. Press the SELF TEST button (located under the keyboard at the righthand top of the pedestal) and hold it down.
3. Press the MASTER RESET button (located next to the SELF TEST button) and release it.
4. The keyboard LED lights begin to cycle. When this happens, release the SELF TEST button.
5. The keyboard LED lights cycle twice in the course of Self Test. If there is a malfunction, the LED lights remain lit in a hexadecimal binary malfunction code. Refer to the sections describing Self Test in Volume 1 and 2 of this manual. If there is no malfunction after cycling twice, the bell sounds and the CAPS key light blinks. The cursor should appear in the upper lefthand corner of the screen.

Upon completion of steps 1 through 5, 70% of the terminal circuitry has been tested. Proper terminal operation has been verified.

CONNECTING TO A HOST COMPUTER

The Host Port RS-232 Cable may be connected to the host computer in three ways that largely depend on the distance between the terminal and the host computer. In the first way, the cable may be plugged directly into the host computer (although usually an asynchronous modem eliminator is needed). In the second way, the cable may be plugged into a "short haul" modem or line driver device. is used when the host computer is in the same building or building complex, but not in the same room or immediate area. The third way uses a telephone line connection between modems.

TELEPHONE LINE CONNECTION

A modulator-demodulator (modem) is required to establish a telephone line connection. There are a number of specialized modems available. The type required depends upon the specific needs of the installation.

A host port RS-232 cable is included with the 4114 as a standard accessory. To connect to a modem, connect one end of the RS-232 cable to the plug on the rear of the 4114 designated "To Modem". Connect the other end of the cable to the modem to be used.

INSTALLATION

Once the terminal is connected to the modem, a standard procedure for connecting to the computer is as follows (this procedure may vary in some details for different computer installations):

1. Power-up the equipment.
2. Dial the number of the computer installation.
3. When the computer responds with an audible tone, place the telephone headset on the cradle provided in the modem, or push the button marked DATA and hang up the headset, or perform such other function as required by the modem in use.
4. Perform the sign-on procedure as required by the particular computer installation.

TESTING COMMUNICATION

Once the terminal has been connected to the computer (in any of the three basic ways using the RS-232 cable), perform the sign-on ("log-in", "log-on") procedure that is required by the host computer. Once the user has "signed-on" to the system, the communication lines between the host computer and the terminal should now be open. The user can now "talk"

to the computer. The user should try a few of the basic system commands to ensure that no communication problems exist between the terminal and the host computer.

Testing the communication provides the final verification of proper operation. The 4114 is now ready for use.

PACKAGING FOR SHIPMENT

If this terminal is to be shipped long distances by commercial transportation, it is recommended that the terminal be packaged as originally received from the factory. Cartons and packaging material in which the terminal components were shipped should be saved for this purpose.

Also, if this terminal is to be shipped to a Tektronix Service Center for service or repair, attach a tag to the terminal showing the following: Owner of the terminal (with address), the name of a person at your firm who can be contacted, complete terminal type and serial number, and an explanation of the service required.

Packaging configuration illustrations are listed in Table 2-1. Refer to them when repackaging for shipment.

Table 2-1

PACKAGING CONFIGURATIONS

Package	Figure
Display Module	2-3
Accessory Box	2-4
Pedestal	2-5

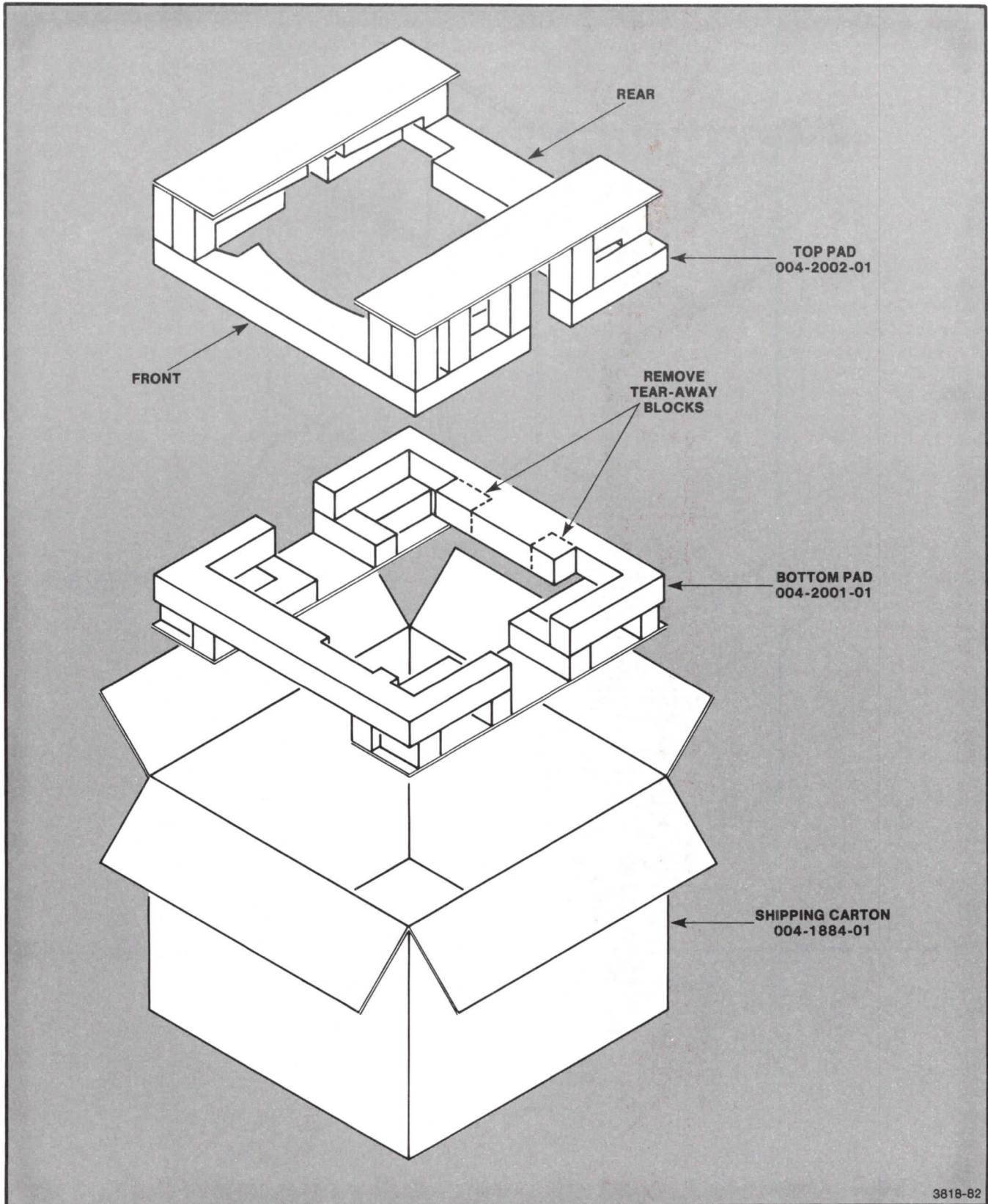

Figure 2-3. Display Module Packaging Configuration.

INSTALLATION

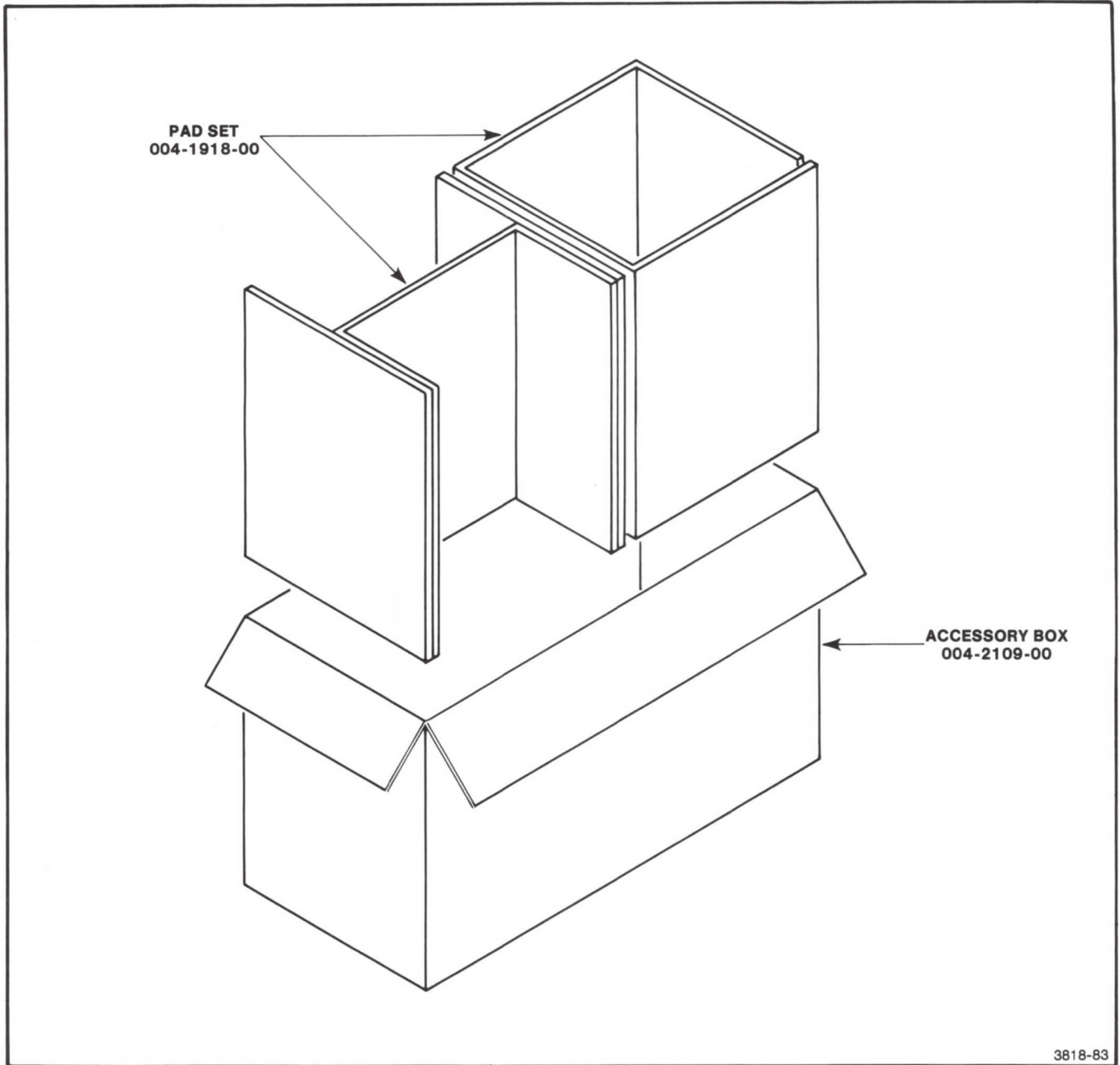

Figure 2-4. Accessory Box Packaging Configuration.

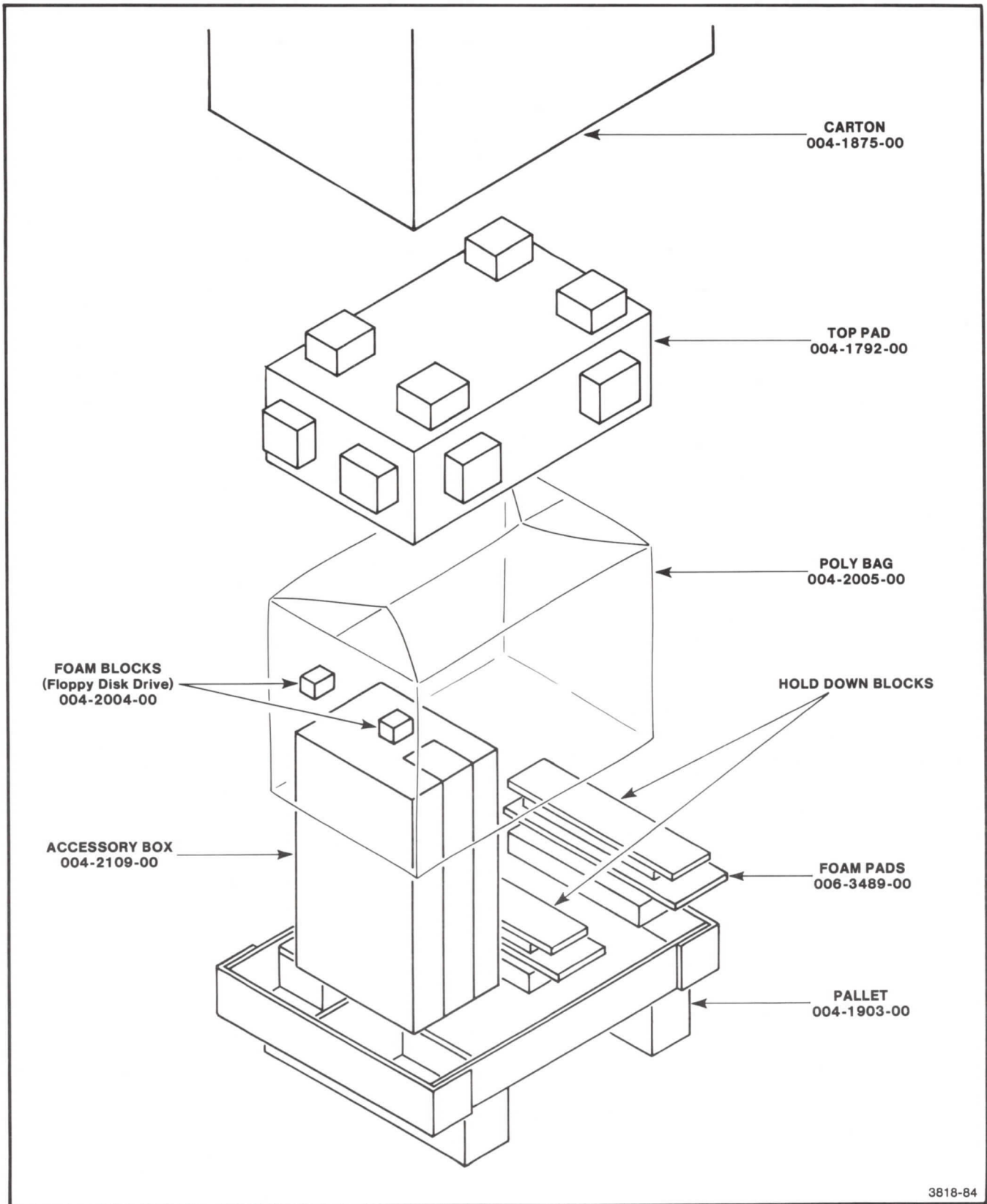

Figure 2-5. Pedestal Packaging Configuration.

Section 3

STRAP INFORMATION

INTRODUCTION

The terminal has straps on the various circuit boards, which provide flexibility in its operating parameters. There are two kinds of straps: cut straps and jumper straps. In cases where the terminal was designed to function one way, but provisions were made for future design enhancements, cut straps are often used. Cut straps are also used for straps that are changed

infrequently. Jumper straps, however, are changed much more often than cut straps. Most straps in the terminal are jumper straps.

This summary gives the strap settings for each standard circuit board or module in the terminal.

PEDESTAL INVERTER BOARD

The jumper straps J61 and J62 select either 230 Vac or 115 Vac. See Figure 3-1. The power supply line voltage input is factory set for 115 Vac.

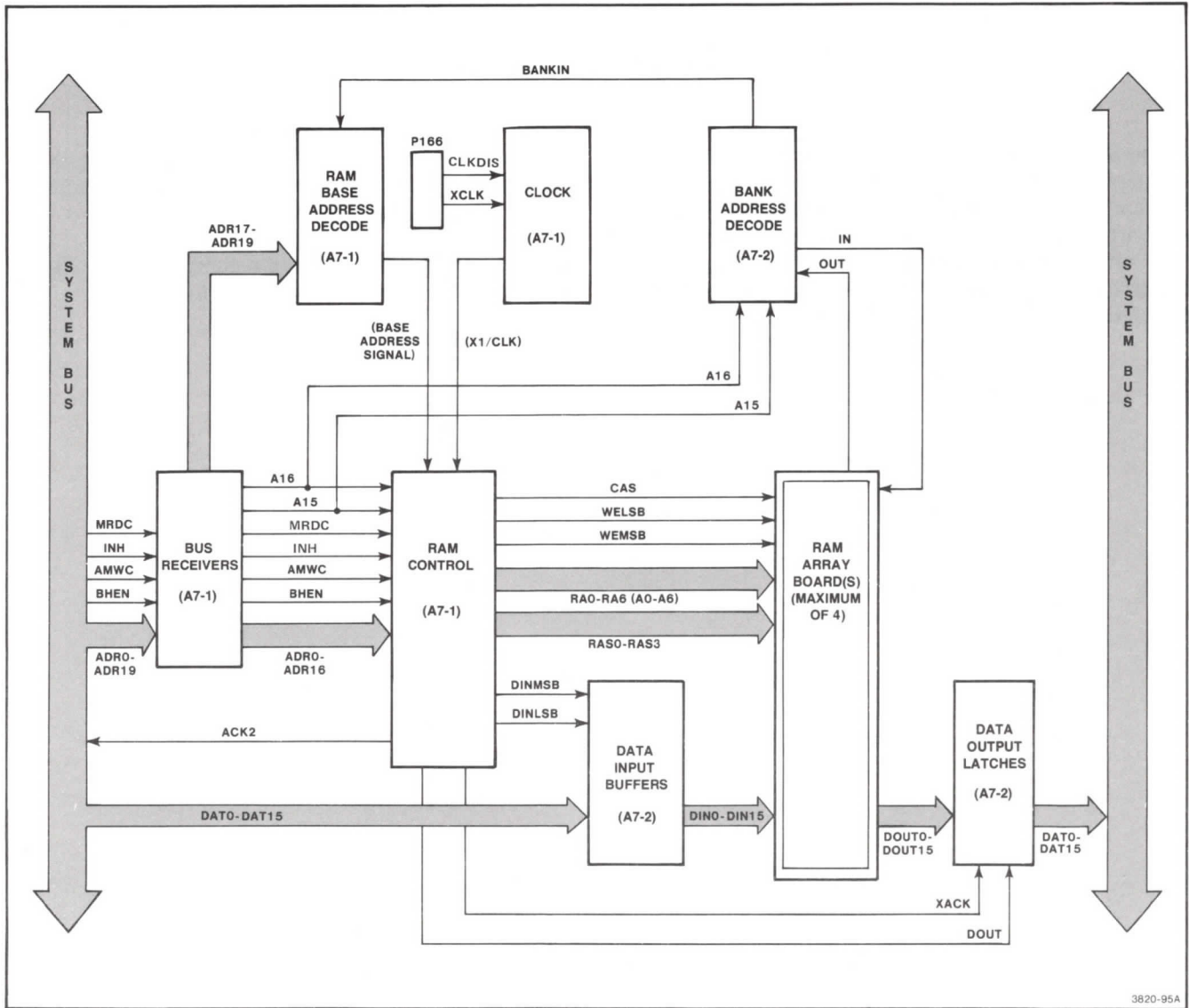

Figure 3-1. Power Supply Inverter Board; AC Input Jumper in 115 Vac Position.

PROCESSOR BOARD STRAPS

Several cut and jumper straps are provided on the Processor board. Straps labeled "Jxxx" have square pins with movable jumpers. Straps labeled "Wxxx" are cut straps; they consist of circuit traces on layer 1 of the ECB with no square pins. Table 3-1 lists these strap settings.

Table 3-1
PROCESSOR BOARD STRAP SETTINGS

Strap Label	Definition
ROM Logic Straps:	
ROM Size Strap (W126)	Selects either 16K bit or 32K bit ROMs, or disable all Processor board ROMs.
ROM Wait States (W475)	Normally strapped for ONE wait state. If all the ROMs on the Processor board are fast enough, this strap may be changed to indicate ZERO wait states.
ROM Type Straps (J226, J326, J426, J427)	There is one set of straps for each two-ROM bank of ROMs. These straps configure the board for the pin-out of the ROM being used.
BLCK Source: (W455, W456)	Normally strapped to "on-board." If more than one Processor board is used in the system, only one should be strapped to "on-board;" all others should be strapped to "off-board."
Interrupt Level Straps: (W470)	The Processor can generate three different interrupts to the 8086 bus. These straps define the interrupt priority levels of the three different interrupts. Normally, the "host port receiver interrupts" are set to interrupt level 0, "keyboard interrupts" set to level 4, and "host port transmitter" are set to interrupt level 5.
Bus Timeout Enable: (W561)	Prevents the Processor board from driving ACK1-0 on a bus timeout. Used for multi-Processor board systems.
Test 1 and Test 2 (J150 and J125)	Tests 1 and 2 disable clocks on the Processor board for ATE (automated test equipment) testing.
RS-232-C/RS-232-A: (J522)	This is normally set for RS-232-C. When restrapped for RS-232-A, the SRTS (Secondary Request To Send) signal is sent to Pin 11 of the 25-pin RS-232 connector rather than to Pin 19.

KEYBOARD STRAPS

The Keyboard cut straps allow the firmware to interpret key strokes according to languages other than English. This set consists of four individual cut straps labeled E1 through E4 (labeled W1-W4 on schematic A4-1). The combinations of these straps are read as one hexadecimal number which corresponds to certain keyboard options. See Table 3-2.

Table 3-2
KEYBOARD LANGUAGE OPTION STRAPS

Language	Option Number	Open Cut Strap	Hex Code
Standard	—	none	00
United Kingdom	4A	E4	08
Swedish	4C	E2	02
APL	4E	E1	01
Danish/Norwegian	4F	E2 & E3	06

RAM/ROM AND RAM CONTROLLER BOARD STRAPS

To install optional RAM memory, one or more RAM Controller boards must be installed in the card cage. Each RAM Controller board has sockets for four RAM Array boards. The RAM Array boards contain 32K-byte banks of memory. Since six RAM Controller boards can be installed in the terminal, it is necessary to specify the starting address of the four RAM banks on each RAM Controller board.

Strap J165 (see Figure 3-2) sets the Base Address for all memory on the board. Set the strap to '1,' for the RAM Controller nearest the processor. Set the strap on the other RAM Controller boards to "2", "3", "4", etc., as they are placed in order farther away from the Processor board. Strap J165 allows strapping for a maximum of six RAM Controller boards.

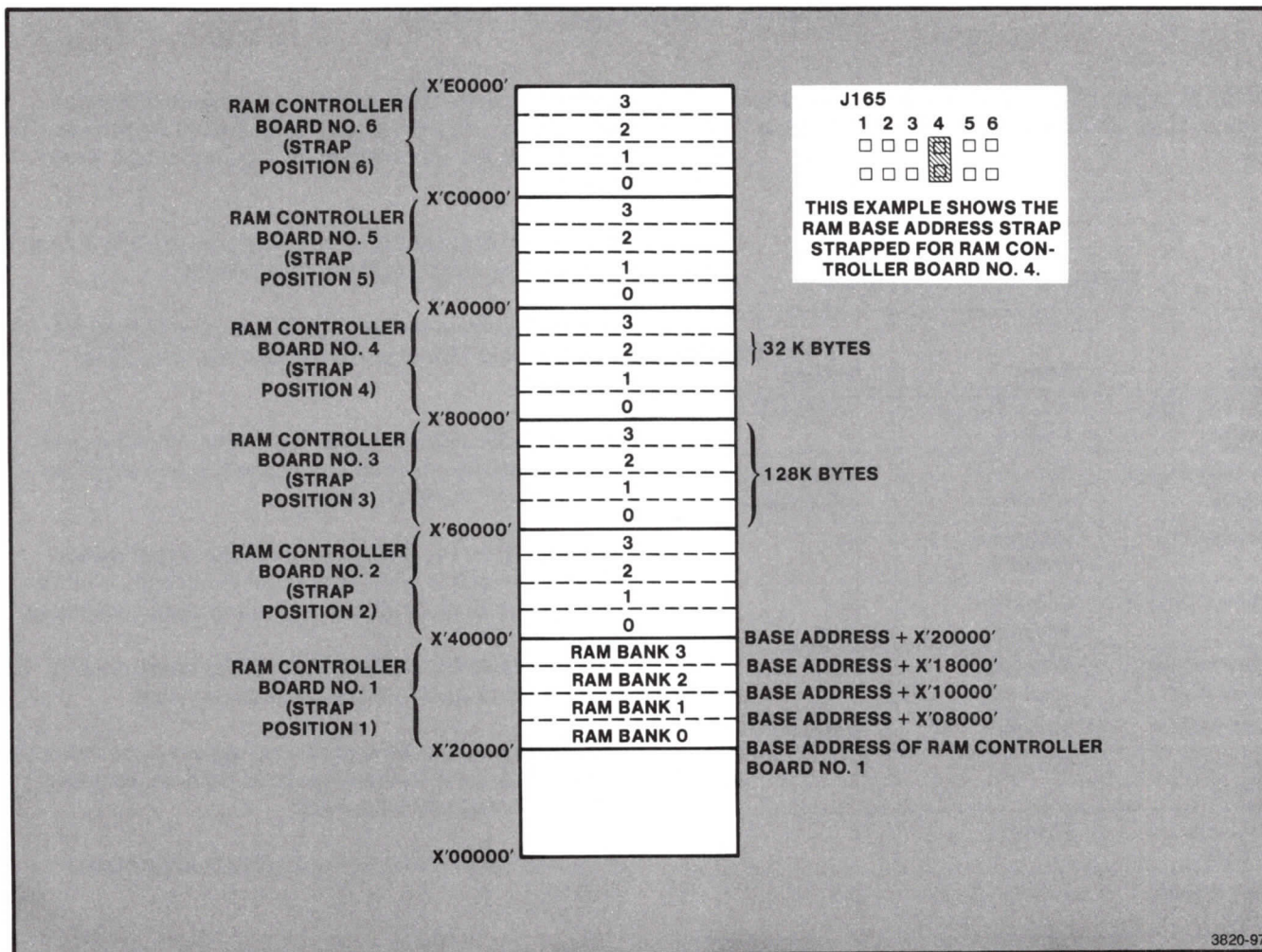

Figure 3-2. RAM Controller Board Base Address Strap Positions.

DISPLAY MODULE STRAPS

There are eight strap options in the terminal display module. They are located on the boards listed in Table 3-3.

Table 3-3
DISPLAY MODULE STRAPS

Strap	Board	Normal Operating Setting
100, 120, 220, 240Vac	Power Supply Module	Selectable
X-Y Interchange Polarity	Deflection Amplifier	Varies with crt configuration
Hold IN/OUT	Deflection Amplifier	IN
Antiburn IN/OUT	Deflection Amplifier	IN
SLU-0 recovery time FAST/SLO	Deflection Amplifier	FAST
Erase TEST/N	Storage	N (normal)
View Reset Z/TRUZ	Storage	Z
View Reset Z/GBUSY	Storage	Z
Z Axis Polarity Z1/Z-0	HV & Z Axis	Z-0

Five of the eight strap options are used to match the operational requirements of the pedestal. These are preset and are not changed during normal use. They are:

- Z Axis input polarity on the High Voltage and Z Axis board for selecting the Z-Axis polarity.
- View Reset on the Storage board for selecting the signal line TRU-Z or GB to reset the View Timer Control.
- Hold mode control on the Deflection Amplifier board for selecting between active and inactive Amplifier inputs during Hold mode.
- Antiburn on the Deflection Amplifier board selects between active and inactive beam intensity control during periods of little or no writing beam movement.
- Fast/Slo on the Deflection Amplifier board selects between SLU-0 fast or slow recovery time.

The factory setting for each of the options is as follows: Z-Axis Polarity, Z-0; View Reset, Z; Hold, IN; Antiburn, IN; SLU-0 recovery time, FAST.

A detailed description of the display module straps follows.

X AND Y INPUT INTERCHANGE (Deflection Amplifier Board)

These straps are used when the crt needs to be rotated 180 degrees due to aging crt phosphors. See "Rotating the CRT 180 degrees" in Section 11, Vol. 1 (Maintenance). Altering these straps interchanges the $\pm X$ and $\pm Y$ deflection inputs, which causes the crt to write in a different direction. The normal writing pattern is from left to right across the screen, and from top to bottom down the screen.

SELECTING HOLD IN/OUT (Deflection Amplifier Board)

This strap connects the deflection inputs while in Hold mode either to ground or to the Deflection Amplifier board input connectors. In the IN position, when the display enters Hold mode, the deflection inputs are connected to ground. This centers the deflection amplifier again and minimizes the amplifier power dissipation. In the OUT position, when the display enters Hold mode, the deflection inputs remain directly connected to the deflection amplifier input connectors.

SELECTING ANTIBURN IN/OUT (Deflection Amplifier Board)

CAUTION

This strap is always factory preset to the IN position. To avoid possible crt damage, it should not be set to the OUT position except for the adjustment of the display module.

Antiburn protects the crt from slow-moving, high-intensity beams. In the IN position, the antiburn amplifier controls the beam intensity. In the OUT position, there is no antiburn control and a slow-moving, high-intensity beam may damage the crt.

SELECTING FAST/SLO (Deflection Amplifier Board)

This strap option is used for a setting of SLU fast or slow recovery time. In the FAST position, the SLU signal provides only enough time for the settling of the deflection amplifier. In the SLO position, the SLU time is increased which provides additional settling time.

The display module is designed to be compatible with the pedestal with the FAST/SLO signal set in the FAST position. THIS SETTING SHOULD NOT BE CHANGED.

SELECTING N/TEST (Storage Board)

This strap is used only during display adjustment and should be left in the N position for normal operation. TEST will cause the crt to erase approximately every three seconds.

SELECTING Z RESET SELECT (Storage Board)

This strap selects the TRU-Z signal or a transition signal on the GBUSY signal line (GB) to reset the view counter. Resetting the view counter prevents the display module from going into Hold mode and ultimately into Auto Erase mode. In the TRU-Z position, each Z Axis positive transition resets the view counter, while in the GB position, any positive transition (from either a positive or negative pulse) of the GBUSY-0 signal line resets the view counter. An additional signal line, VIEW-0, also controls the view counter. A low on the VIEW-0 signal line always resets the view counter.

SELECTING Z AXIS INPUT POLARITY (HV & Z Axis Board)

CAUTION

The display module uses a factory setting of Z-0 in order to be compatible with the pedestal. THIS SETTING SHOULD NOT BE CHANGED.

The display module is designed to accept either a low or high true TTL signal. To accomplish this, a set of two straps — labeled Z-1 and Z-0 — on the High Voltage and Z Axis board is set to select which true level of Z is used by the display control. If a low true TTL signal is used for Z, the two straps must be set in the Z-0 position. The writing beam is then turned off when the Z Axis input signal rises to at least + 2 V, and turns on with a signal of less than + 0.8 V. Conversely, if a high true TTL signal is used for Z, the two straps must be set in the Z-1 position. The writing beam is then turned on when the Z Axis input signal rises to at least + 2 V, and turns off with a signal of less than + .8 V.

STRAP INFORMATION

SELECTING LINE OPERATING VOLTAGE

If it is necessary to change the transformer terminal connections to conform to your line voltage range, use the following procedure:

1. Remove the cover plate protecting the power transformer, the input power assembly, and the line fuse.
2. Connect or change the straps on the five-terminal barrier strip to conform to the desired line voltage using the illustration in Figure 3-3 as a guide.
3. Change the fuse, if necessary, to conform to the new operating voltage. The fuse information is shown on the rear of the chassis and repeated in Table 3-4.

4. Replace the cover plate over the Power Input Voltage Selection strip.
5. Change the yellow voltage indicator on the rear panel to indicate the new input line (primary) voltage.

Table 3-4
FUSE SELECTION

Line	Fuse Rating
100 V	5 A SLOW-BLOW
120 V	5 A SLOW-BLOW
220 V	3 A SLOW-BLOW
240 V	3 A SLOW-BLOW

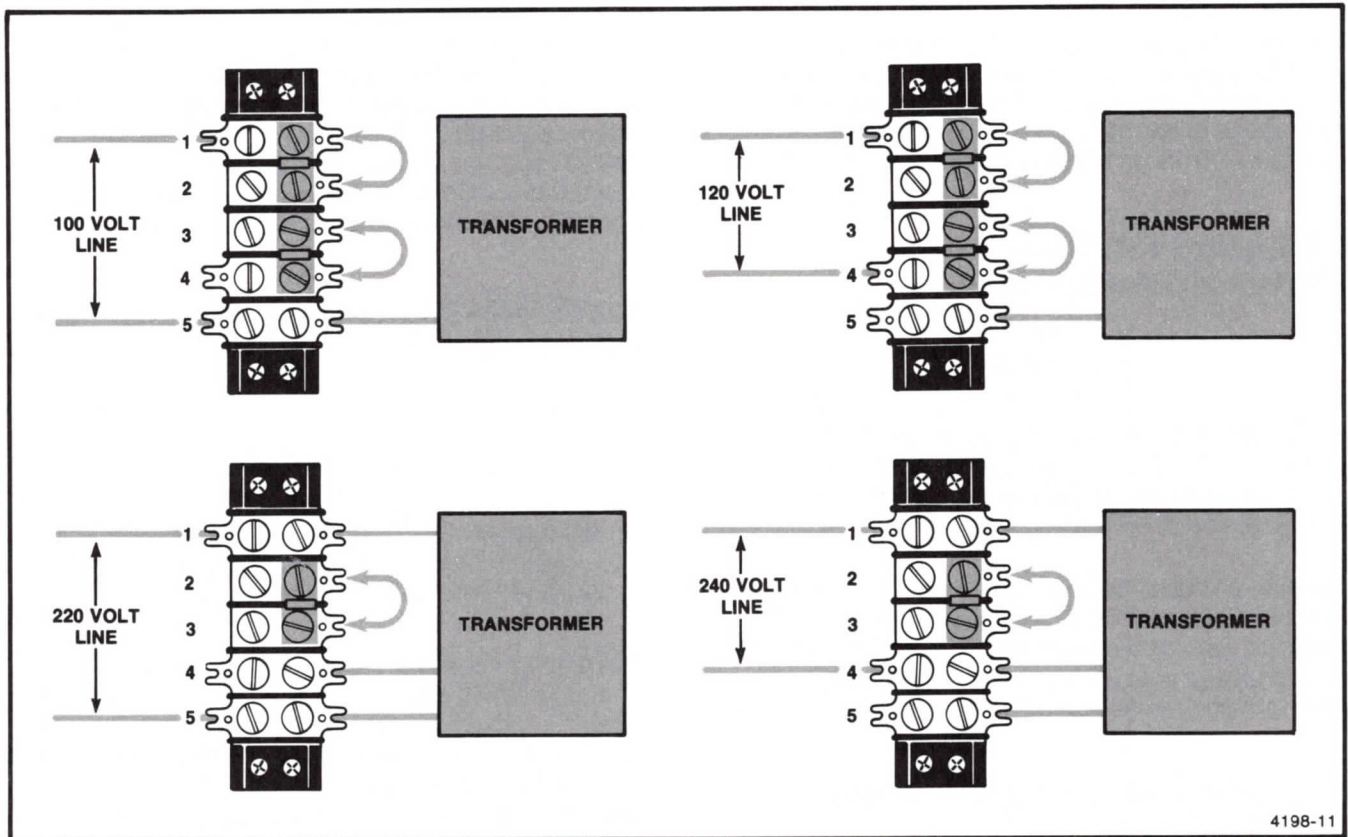

Figure 3-3. Five Terminal Barrier Strip Wiring and Jumper Positions for Line Voltage Selection.

VECTOR GENERATOR BOARD STRAPS

There is only one strap on the Vector Generator board. This is strap J601, which overrides the charge pump

for troubleshooting purposes. The Vector Generator board has no jumper strap on J601 during normal use.

DISPLAY CONTROLLER BOARD STRAPS

The Display Controller board has two cut straps on it, W370 and W570.

W570 selects one of seven bus interrupt levels, 0 through 7. The factory setting is wired to the 6 position.

W370 has two possible positions that select for address decoding. The positions are 0 and 1. The 0 position selects addresses X'00D0' through X'00D7' for decoding, while the 1 position selects addresses X'00D8' through X'00DF' for decoding. The factory preset position is 0.

Section 4

ABBREVIATED ADJUSTMENT

INTRODUCTION

This section is divided into two subsections, the first subsection describes the adjustment procedures for the pedestal part of the terminal. The second subsection describes the terminal display module adjustment procedure.

NOTE

This abbreviated adjustment section should NOT be used as a complete adjustment procedure. It does, however, serve as a checklist for the experienced service technician. For the complete adjustment procedures refer to "Pedestal Adjustment Procedure" and "Display Module Adjustment Procedure" in Volume 1 of this manual. THIS ABBREVIATED ADJUSTMENT SECTION DOES NOT CONTAIN "NOTES," "CAUTIONS," OR "WARNINGS."

PEDESTAL ADJUSTMENT

Gather the equipment necessary for adjusting the terminal, make sure the terminal is operating under performance specifications, remove the pedestal front panel, and perform an inspection with the power off.

1. LOW VOLTAGE POWER SUPPLY (R685)

- a. Install the 41XX Logic Extender board. (This board contains the test points needed for the power supply checks).
- b. CHECK — TP 75 on the Logic Extender board for + 5.105 V to + 5.115 V.
- c. ADJUST — + 5 V (R685) for + 5.1 V at TP 75.
- d. CHECK — the + 12.00 V supply at TP 79 for + 11.88 V to + 12.12 V.
- e. CHECK — the -5.2 V supply at TP 5 for -5.05 V to -5.35 V.
- f. CHECK — the -12.00 V supply at TP 1 for -11.88 V to -12.12 V.
- g. CHECK — power supply ripple on the + 5.1, + 12.00, -12.00, and the -5.2 V supplies is 100 mV or less.

ABBREVIATED ADJUSTMENT

- h. CHECK — the INIT waveform at TP9 and the PDWN-INIT waveform at TP 75 during the power up and power down sequences. Refer to Figures 4-1 and 4-2.
- i. CHECK — the PFAIL waveform at TP 7. Refer to Figure 4-3.

2. VECTOR CLOSURE (R1,R3)

- a. Display the Status message on the screen.
- b. ADJUST — R1 and R3 for maximum vector closure using the letter "B" in the status message. See the Adjustment foldout for the location of R1 and R3.

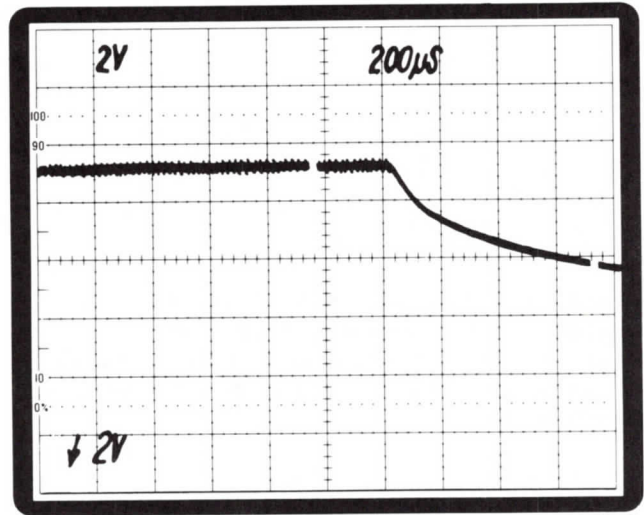

2461-6

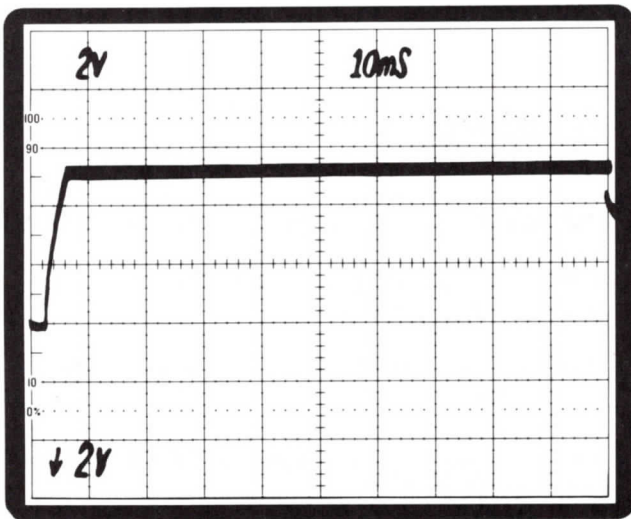

2461-5

Figure 4-1. INIT Waveform.

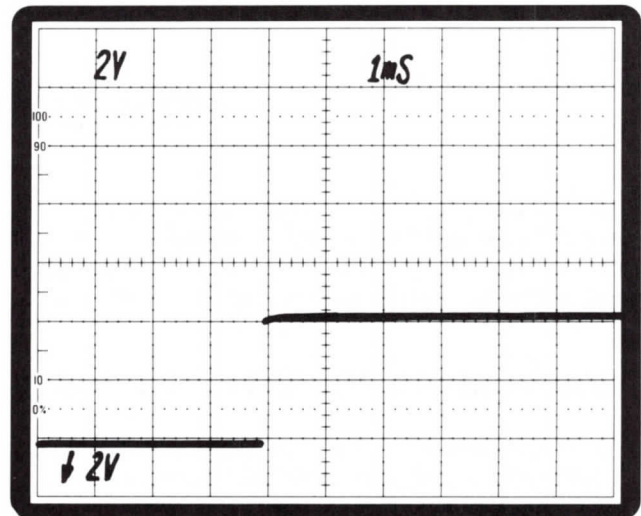

2461-7

Figure 4-3. PFAIL Waveform.

3. VECTOR GENERATOR BOARD (R424, R425, R426, R427, R605, R704)

- a. Install the Vector Generator board on the 41XX Logic Extender board.
- b. ADJUST — R425 (X DAC offset) for -4.950 V at TP 706 with the writing beam positioned to 0,0.
- c. ADJUST — R426 (Y DAC offset) for -4.873 V at TP 716 with the writing beam at 0,0.
- d. ADJUST — R424 (X DAC gain) for $+4.950$ V at TP 706 with the writing beam at 1023,4095.
- e. Adjust — R427 (Y DAC gain) for $+4.873$ V at TP 716 with the writing beam at 1023,4095.
- f. CHECK — the values in steps 2, 3, 4, and 5 again for any changes.
- g. ADJUST — R605 (Pump Up/Down) and R704 (Pump Down) for the best waveform at TP502 and TP 525 (externally triggered) while obtaining an optimum charge pump pattern on the display. See Figures 4-4 and 4-5.
- h. Turn off the terminal, remove the test board, install the Vector Generator board again, and replace the pedestal cover.

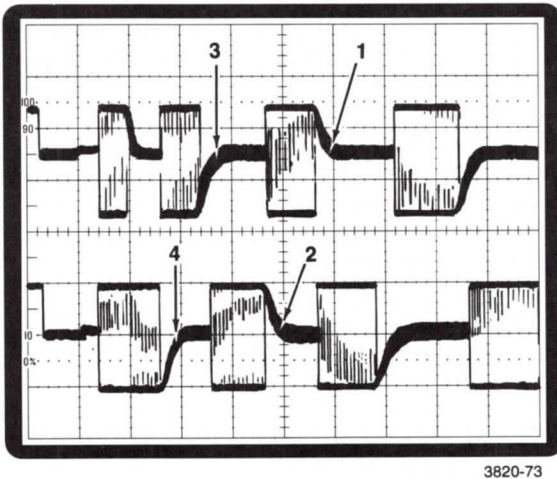

Figure 4-4. Charge Pump Waveform.

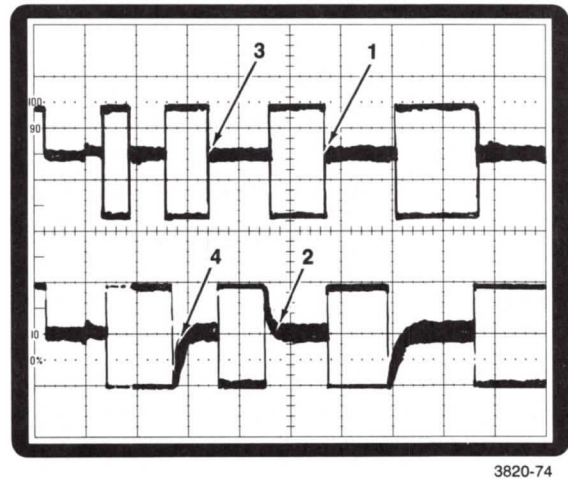

Figure 4-5. Adjusted Charge Pump Waveform.

DISPLAY ADJUSTMENT

Gather the equipment necessary for adjusting the terminal, make sure the terminal is operating under performance specifications, remove the pedestal front panel, and do an inspection with the power off.

1. LOW VOLTAGE POWER SUPPLY (R166)

- a. Turn on the terminal and press the PAGE key.
- b. CHECK — for voltage tolerances and ripple in Table 4-1 measured on the Interconnect board.
- c. ADJUST — R166 (+ 15 Adj) on the LVPS board for + 14.95 V to + 15.03 V.

Table 4-1

LVPS VOLTAGE TOLERANCES AND RIPPLE

Voltage	Voltage Tolerance	Maximum Ripple
+ 15 V (reg)	+ 14.97 V to + 15.03 V	5 mV p-p
- 15 V (reg)	- 14.85 V to - 15.15 V	5 mV p-p
+ 5 V (reg)	+ 4.8 V to + 5.2 V	10 mV p-p
+ 12 V (unreg)	no tolerance (about + 9 V)	1.5 V p-p
- 12 V (unreg)	no tolerance (about - 9 V)	1.5 V p-p
+ 20 V (unreg)	no tolerance	1.2 V p-p
- 20 V (unreg)	no tolerance	1.2 V p-p
+ 175 V (unreg)	no tolerance	7.0 V p-p
+ 290 V (reg)	+ 287.0 V to + 293.0 V	100 mV p-p
+ 490 V (unreg)	no tolerance	5.0 V p-p

2. HIGH VOLTAGE CHECK

- a. Check pin 3 of the crt for - 5700 V to - 6300 V at 120 Vac. It should not vary more than + , - 60 V at 108 Vac and 132 Vac.

3. STORAGE BOARD (R197,R198,R295)

- a. CHECK — TP 91 for 142.5 V to 157.5 V.
- b. ADJUST — R295 (OP LEVEL) so that the crt gets bright but does not store. Check the OP LEVEL voltage at TP 94.
- c. ADJUST — R198 (CE-2) for a flood gun pattern 1/16 inch from the edge of the phosphor. Check the CE-2 voltage at TP 93.
- d. ADJUST — R197 (CE-1) for uniform background illumination. The CE1 voltage at TP 92 should be about 5 V higher than CE-1. Make sure that oscillation does not occur due to the interaction between R197 and R198.
- e. Place the DVM probe on TP 91 and press PAGE. The voltage should not change during erasure.

4. STORAGE BOARD ERASE WAVEFORMS (R95,R195)

- a. Turn the power off, change the N/TEST jumper to "TEST", and turn the power back on. Note that the screen erases every 3 seconds.
- b. CHECK — for the Figure 4-6 waveform at TP 94, and verify that its parts conform to the waveforms in Figures 4-7 AND 4-8.

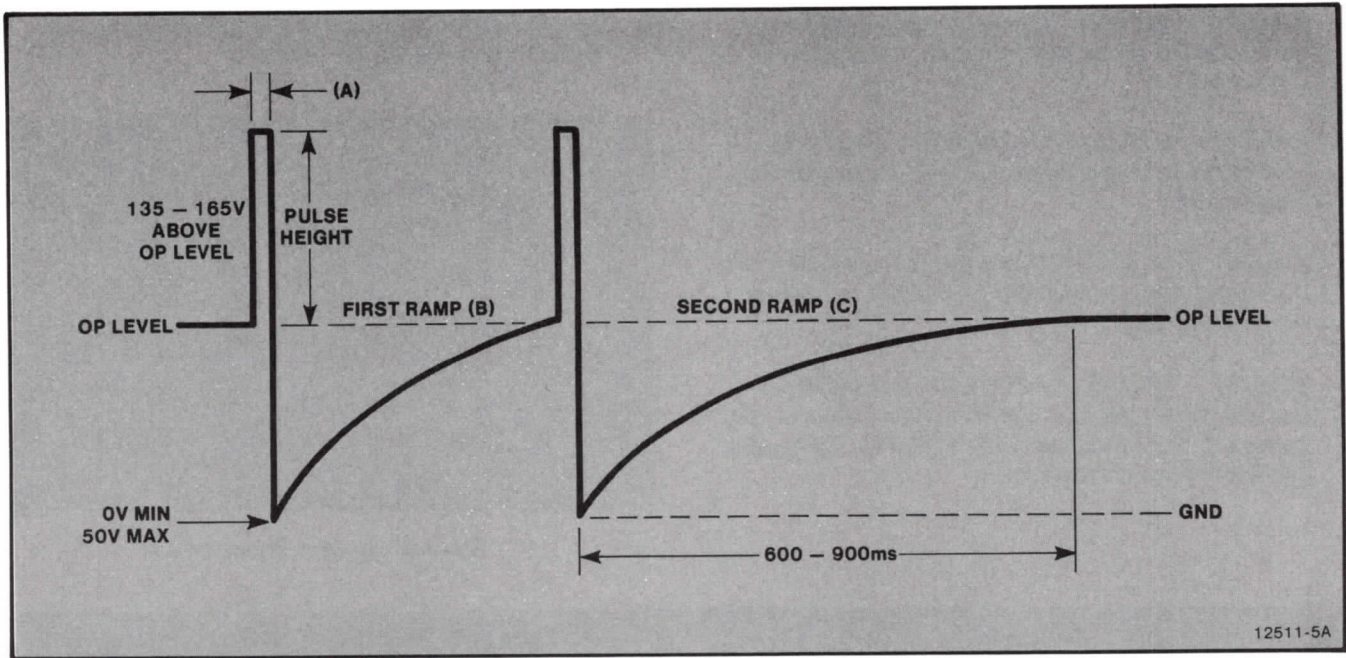

Figure 4-6. Target Erase Waveform.

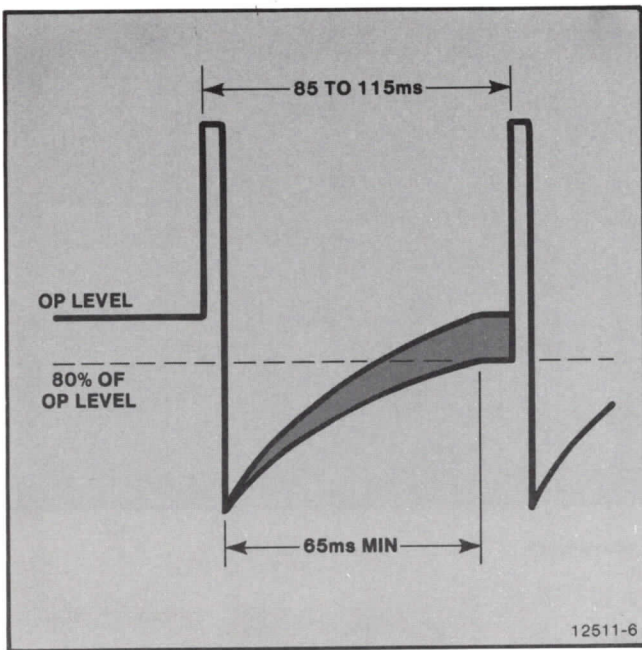

Figure 4-7. Target Erase Waveform Enlarged.

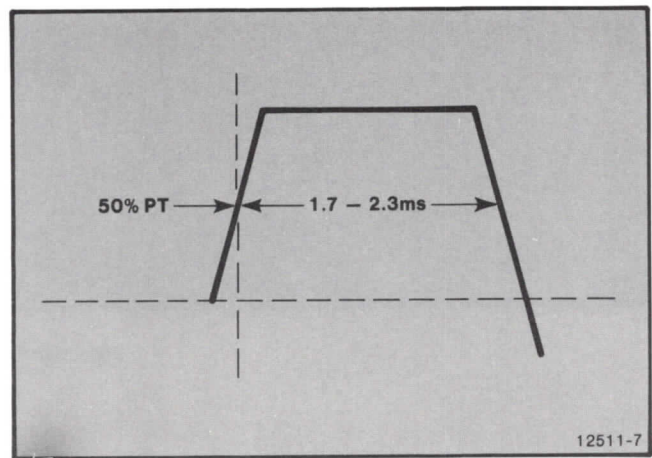

Figure 4-8. Target Erase Pulse Waveform.

ABBREVIATED ADJUSTMENT

- c. CHECK — for the CE-2 waveform at TP 93 and verify that its shape conforms to the waveform in Figure 4-9.
- d. CHECK — for the CE-1 waveform at TP 92 and verify that its shape conforms to the waveform in Figure 4-10.
- e. ADJUST — R95 (CE-1 Pulse Control) while erasing the screen and observing the edges of the screen for full coverage.
- f. ADJUST — R195 (CE-2 Pulse Control) while erasing the screen and observing the edges of the screen for full coverage. The OP LEVEL, CE-1, and CE-2 adjustments interact.

- g. Turn the power off, change the N/TEST jumper to "N", and turn the power back on.

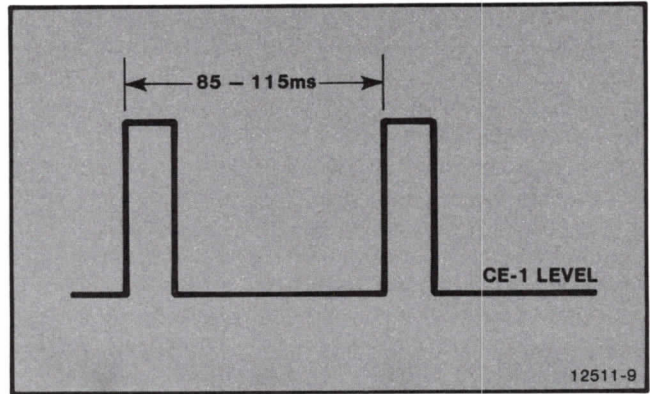

Figure 4-10. CE-1 Waveform.

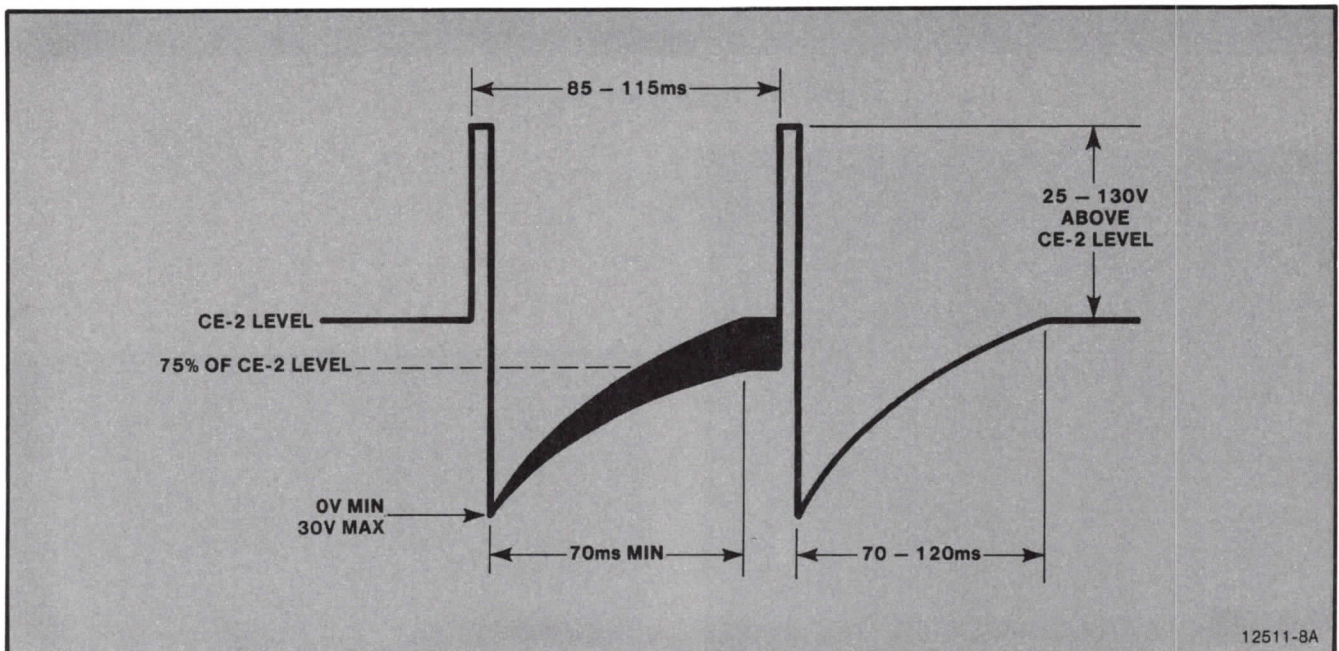

Figure 4-9. CE-2 Waveform.

5. FLOOD GUN ANODE

- a. Press the PAGE key and make sure that Hold mode lasts for 90 to 135 seconds.
- b. CHECK — for the waveform in Figure 4-11 at TP 91 on the Storage board while the terminal is in Hold mode.
- c. CHECK — for a TTL low on Pin 43 of the Interconnect board while the terminal is in Hold mode.

6. GRID BIAS (R288,R429)

- a. Turn the power off, move the antiburn strap from "IN" to "OUT", and turn the power back on.
- b. ADJUST — R429 (CRT BIAS on the HV & Z Axis board) clockwise until a low intensity dot appears in one corner of the cursor. Retrace lines also appear around the cursor. Adjust R288 (CENTER FOCUS on the HV & Z Axis board) for a well-focussed dot, then adjust R429 until the dot just disappears.
- c. CHECK — the voltage at the junction of C436 and CR345 on the HV & Z Axis board.
- d. ADJUST — R429 counterclockwise to increase the measurement to 5 volts.
- e. Turn the power off, move the antiburn strap from "OUT" to "IN", and turn the power back on.

7. NORMAL INTENSITY (R427)

- a. Press and hold down a character key and observe the Figure 4-12 waveform at the top of R246 on the HV & Z Axis board.
- b. ADJUST — R427 for a 40 V to 50 V difference between the most positive points ("crests") of adjacent pulses.

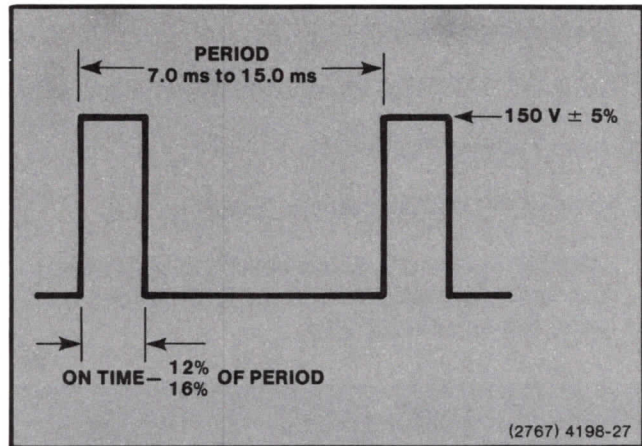

Figure 4-11. Flood Gun Anode Waveform.

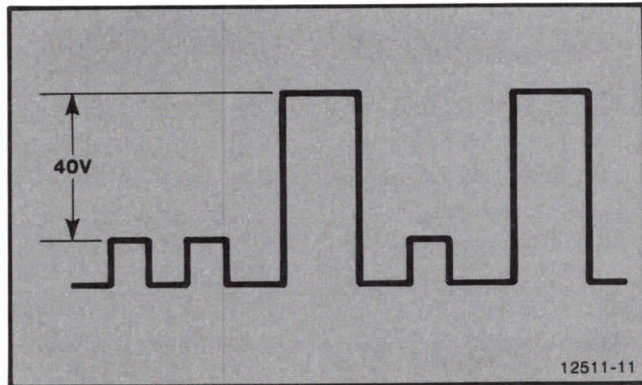

Figure 4-12. Waveform at R246.

ABBREVIATED ADJUSTMENT

8. ORIGIN SHIFT

- Press the PAGE key eight times and watch for seven consecutive origin shifts, with the cursor returning to the upper right on the eighth.

9. FREQUENCY COMPENSATION (R51, R69, R167)

- Display the X COMP pattern (key F3) by using the Self Test procedure.
- ADJUST — R51 (LA Short) and R150 (LA Long) on the Deflection board so that only one line can be seen. Refer to Figure 4-13.
- Display the Y COMP pattern (key F4).
- ADJUST — R69 (SA Short) and R167 (SA Long) on the Deflection board so that only one line can be seen. Refer to Figure 4-13.

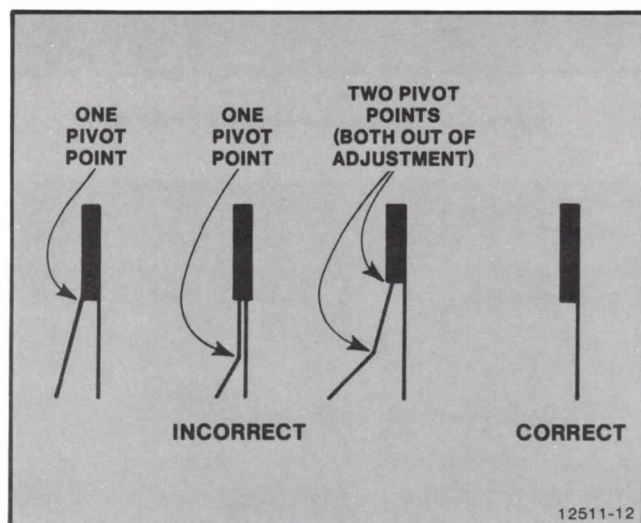

Figure 4-13. X and Y Axis Frequency Compensation Adjustments.

10. GAINS, POSITIONING, AND GEOMETRY (R50, R67, R250, R267, R322, R326)

- Display the GAIN pattern (key F2) by using the Self Test procedure.
- ADJUST — the yoke for a straight, vertical line in the middle of the pattern.
- ADJUST — R250 (Long Axis Pos) and R267 (Long Axis Gain) on the Deflection Amplifier board so that the left and right vertical line midpoints and the top and bottom horizontal line midpoints are equidistant from the edges of the crt.
- ADJUST — R267 (SA Pos) and R67 (SA Gain) so that the midpoint of the top and bottom horizontal lines are the same distance from the top and bottom of the crt screen (or crt filter).
- ADJUST — R326 (LA Geo) on the Deflection Amplifier board for the straightest top line.
- Measure the straightness of the bottom horizontal line.
- ADJUST — R322 (SA Geo) on the Deflection Amplifier board for the straightest lefthand vertical line.
- Measure the straightness of the righthand vertical line.
- CHECK — for excessive deviation from an ideal, straight line in the top horizontal line. If there is none, tighten the yoke.

11. ORTHOGONALITY

- Check for no more than + 1.2 degrees deviation from -90 degrees where the lines cross in the middle of the screen.

12. DYNAMIC FOCUS (R424)

- a. Display the GAIN pattern (key F2).
- b. Attach the oscilloscope probe to the upper end of R235 in the center of the HV & Z Axis board.
- c. ADJUST — R424 (Focus) on the Deflection Amplifier board so that the waveform changes less than 2 V as R128 (Corner Focus) is adjusted. See Figure 4-14.

13. SLU-0

- a. Display the X COMP pattern.
- a. CHECK — for a TTL pulse at Pin 36 of the Interconnect board.

14. FOCUS (R128,R288)

- a. Display the FOCUS pattern.
- b. ADJUST — R288 (Center Focus) and R128 (Corner Focus) on HV & Z Axis board the best center and corner focus while the pattern is writing.

15. DROPOUT

- a. Display the HARD COPY pattern, wait 2 1/2 minutes, and then press the SHIFT key.
- b. Increase the OP LEVEL or NORMAL intensity adjustments in 5 V increments and repeat step a until the minimum number of breaks are seen.

16. BRITE INTENSITY AND DEFOCUS (R34,R415)

- a. Display the DEFOCUS pattern.
- b. ADJUST — R415 (Brite Intensity) on the HV & Z Axis board for 10 V higher than the NORMAL INTENSITY level. See Figure 4-15.
- c. ADJUST — R34 (R34) on the HV & Z Axis board for a difference in characters as they are displayed.

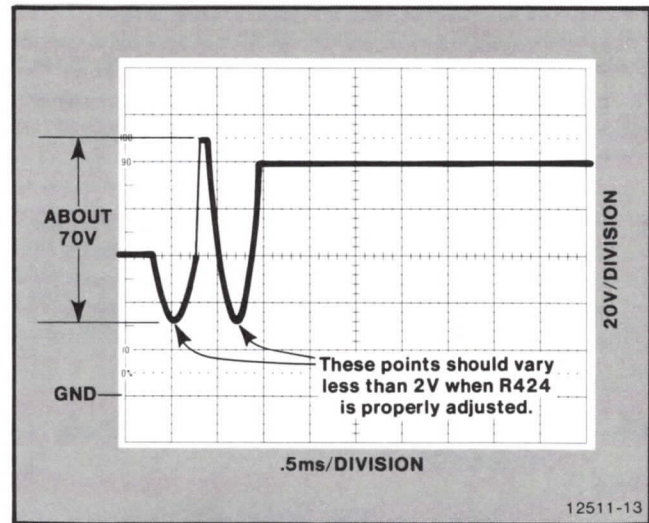

Figure 4-14. Dynamic Focus Waveform.

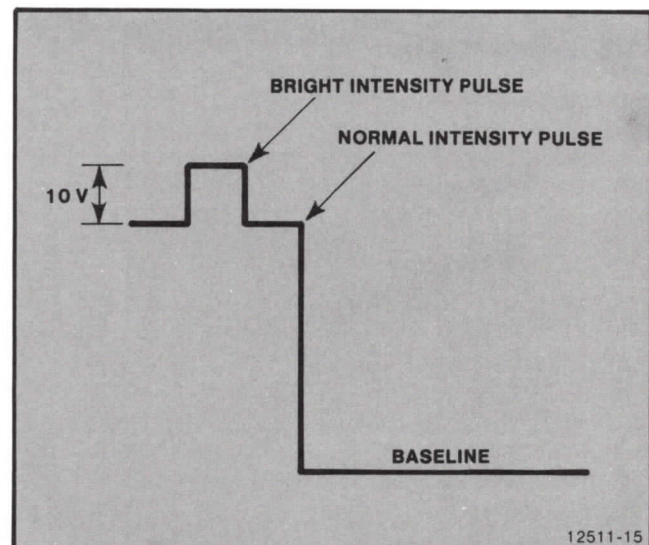

Figure 4-15. Brite Intensity Pulse.

ABBREVIATED ADJUSTMENT

17. WRITE-THRU INTENSITY (R227)

- a. Press the LOCAL key. Then press the ESC key followed by the CONTROL and Z keys at the same time. Use the thumbwheels to control the cross-hairs.
- b. ADJUST — R227 (Write-Thru Intensity) so that the lines disappear when the REFRESH INTENSITY control is fully counterclockwise and the lines store when REFRESH INTENSITY is fully clockwise.

18. HARD COPY (R26,R226,R227,R228, R229,R426)

- a. Connect a 4631 Hard Copy Unit, display the GRAPHIC pattern, press the HARD COPY key, and check for dimming of the screen during scanning.
- b. CHECK — Pin 43 on the Interconnect board during a scan for TTL low.

- c. ADJUST — R226 (Hard Copy Intensity) on the HV & Z Axis board for a non-storing, visible sweep during scanning.
- d. ADJUST — R227 (Hard Copy LA Gain), R228 (Hard Copy SA SA Gain), R229 (Hard Copy LA Pos), R426 (Hard Copy SA Pos), on the Deflection Amplifier board so that a scan covers the pattern with an additional 1/8 inch beyond each edge.
- f. ADJUST — R226 (Hard copy Intensity) for a scan just below storage level.
- g. Adjust — R26 (Hard Copy Threshold) on the HC Amplifier board for high contrast copies without noise. Compare three copies.
- h. Press PAGE, turn off the terminal, and install the cabinet cover again.

This completes the abbreviated adjustment procedures for the pedestal and display module.

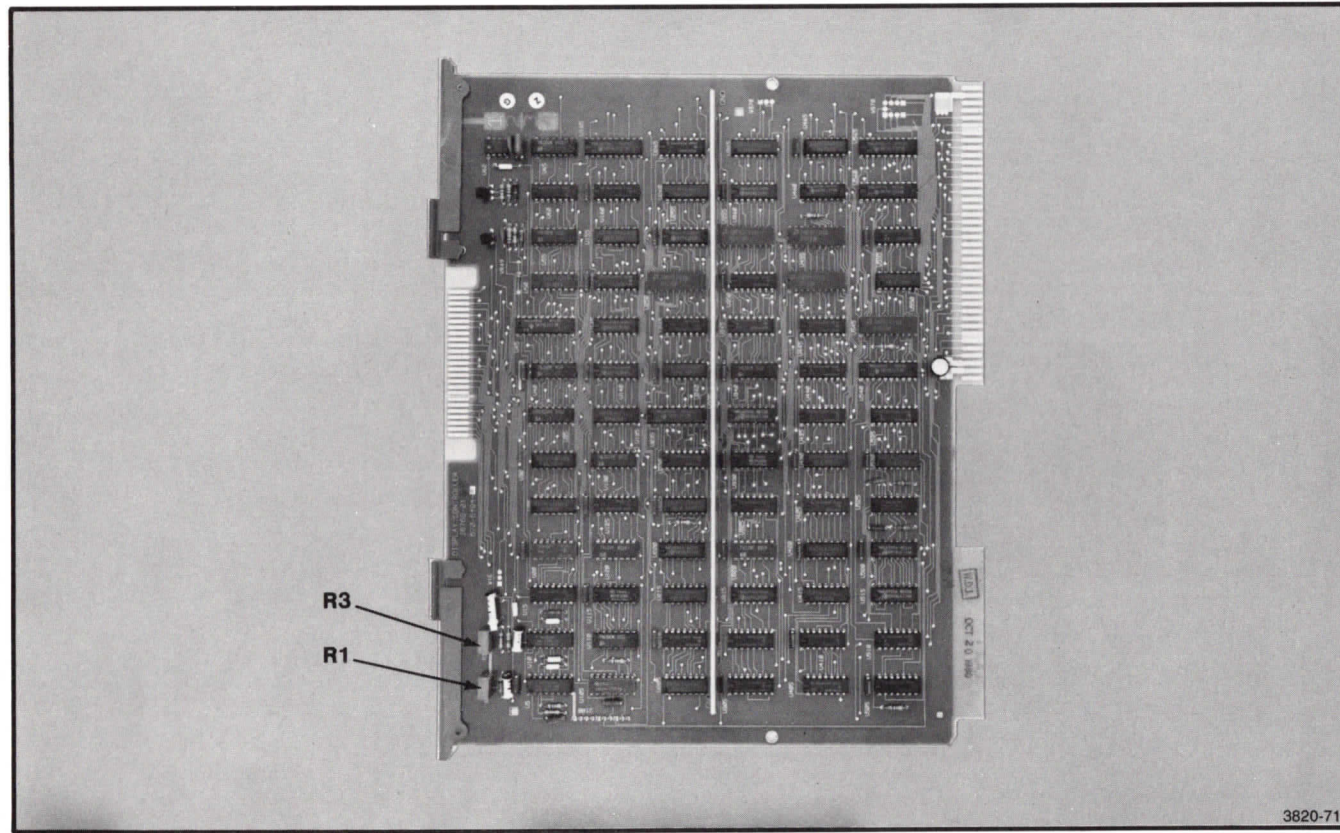

Figure 4-16. Display Controller Board-A8.

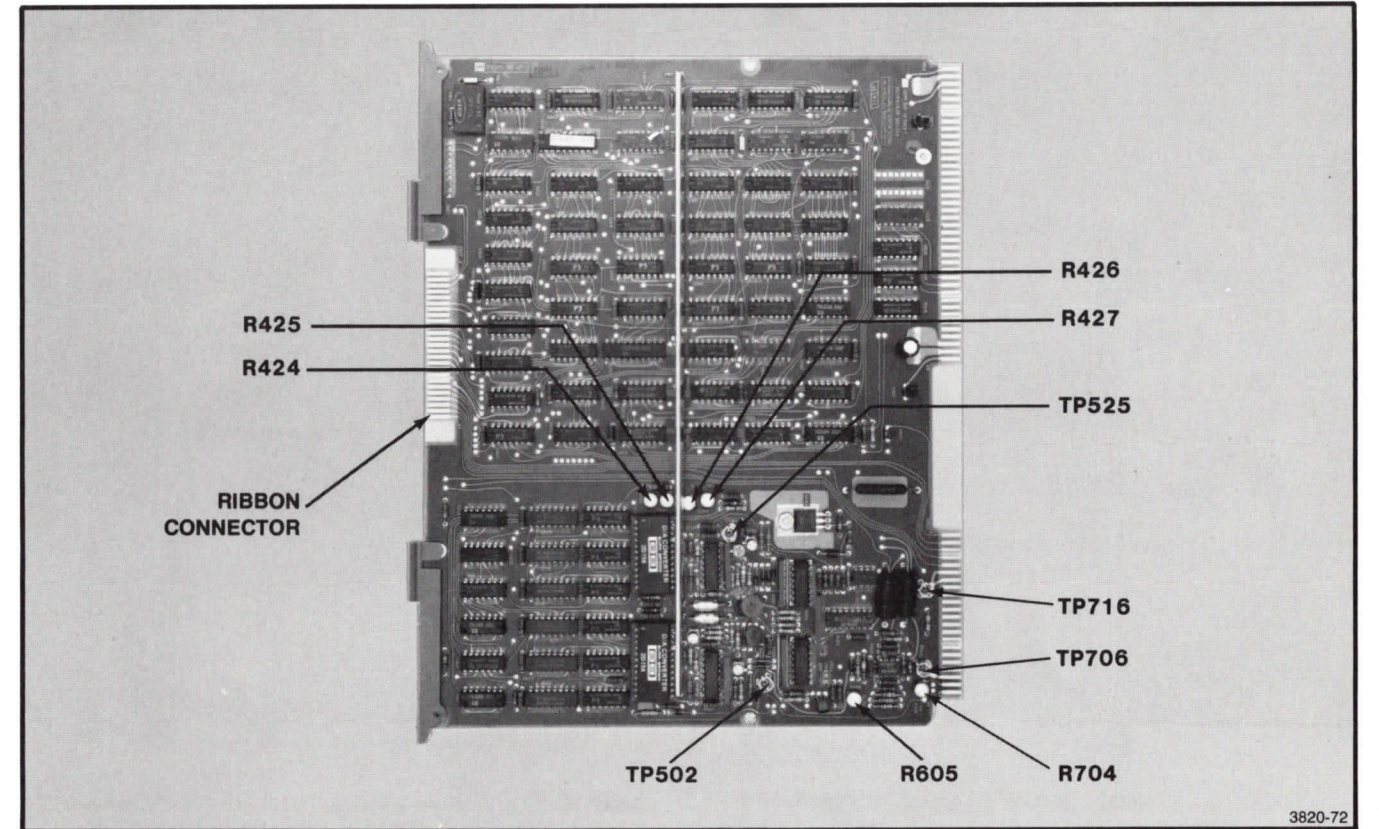

Figure 4-17. Vector Generator Board-A9.

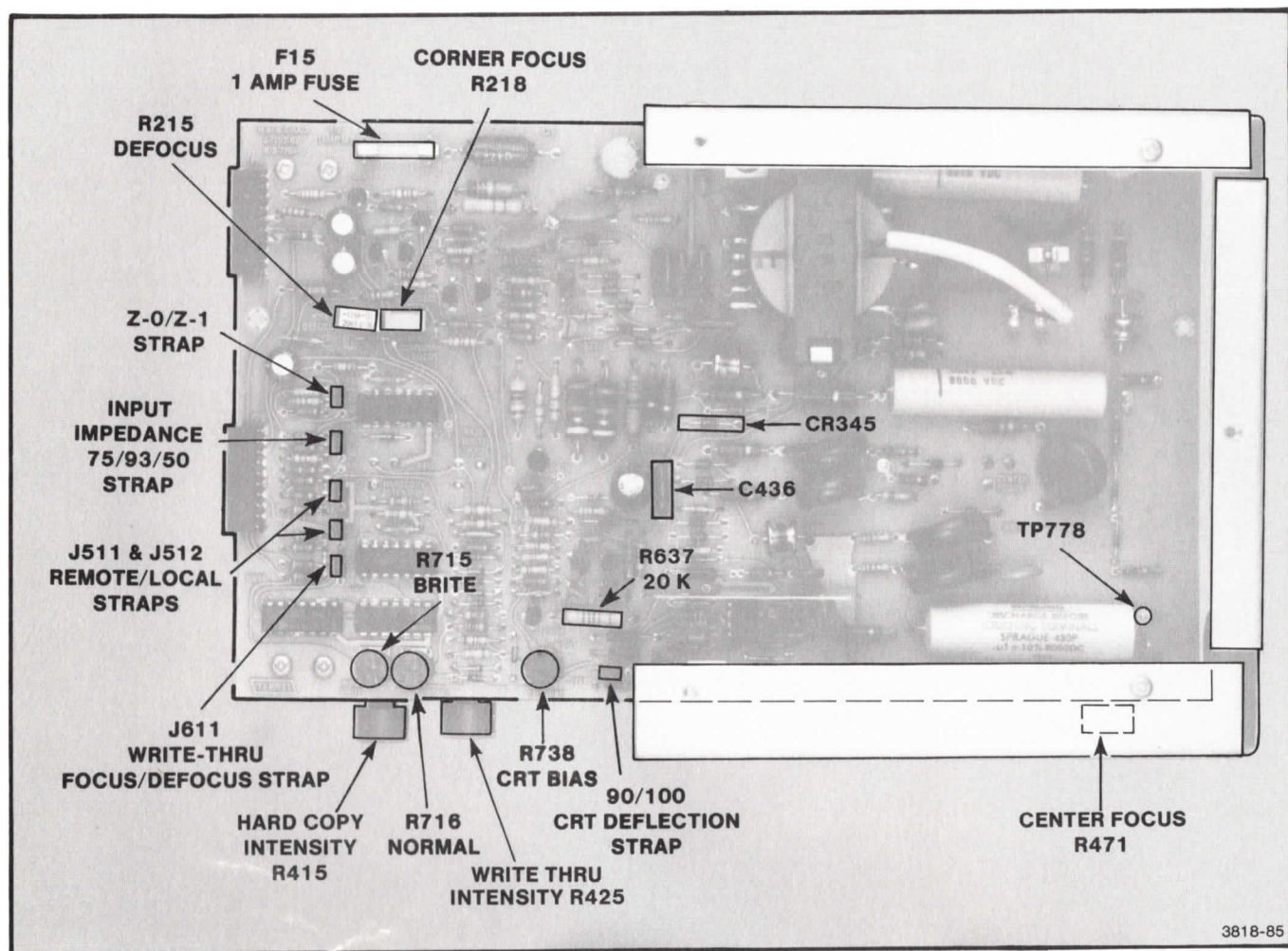

Figure 4-18. High Voltage and Z Axis Board-A16A1.

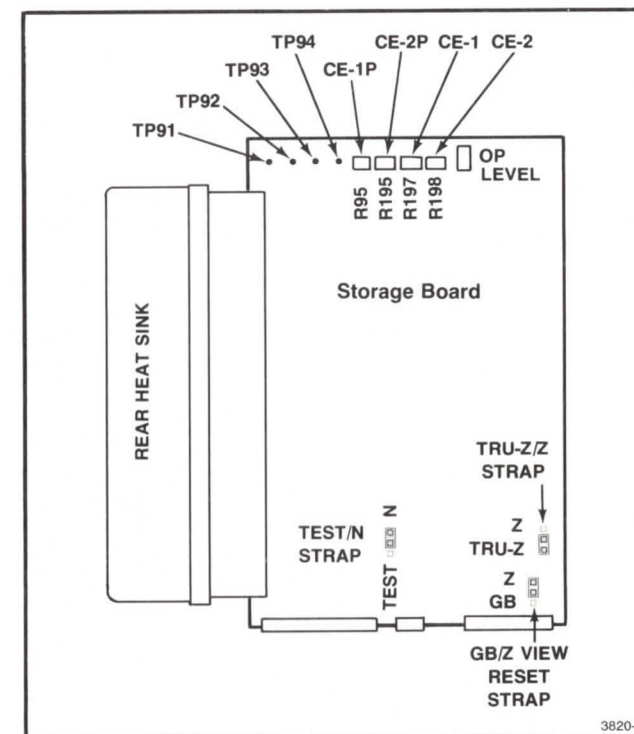

Figure 4-19. Double Erase Storage Board-A13A1.

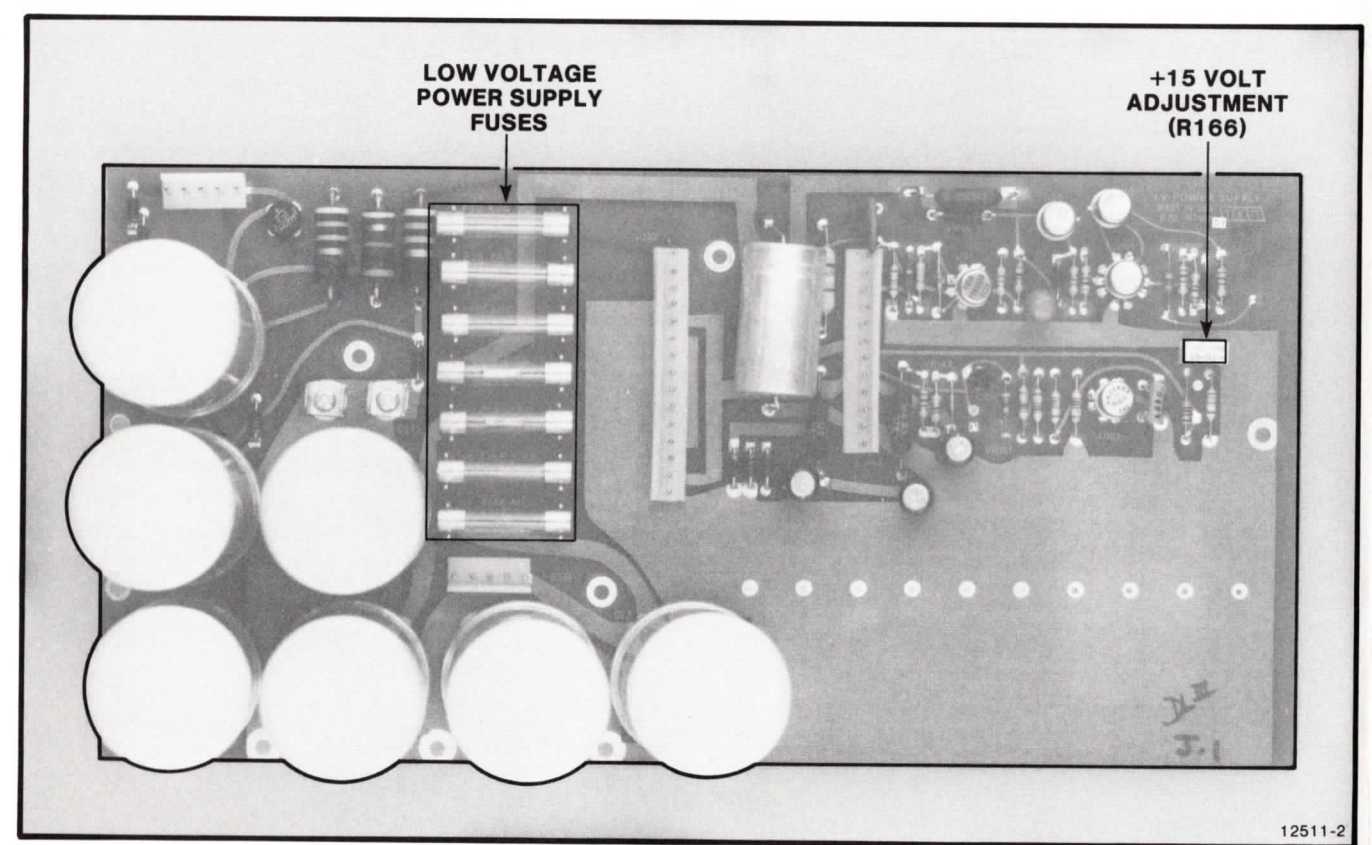

Figure 4-20. Low Voltage Power Supply Board-A12.

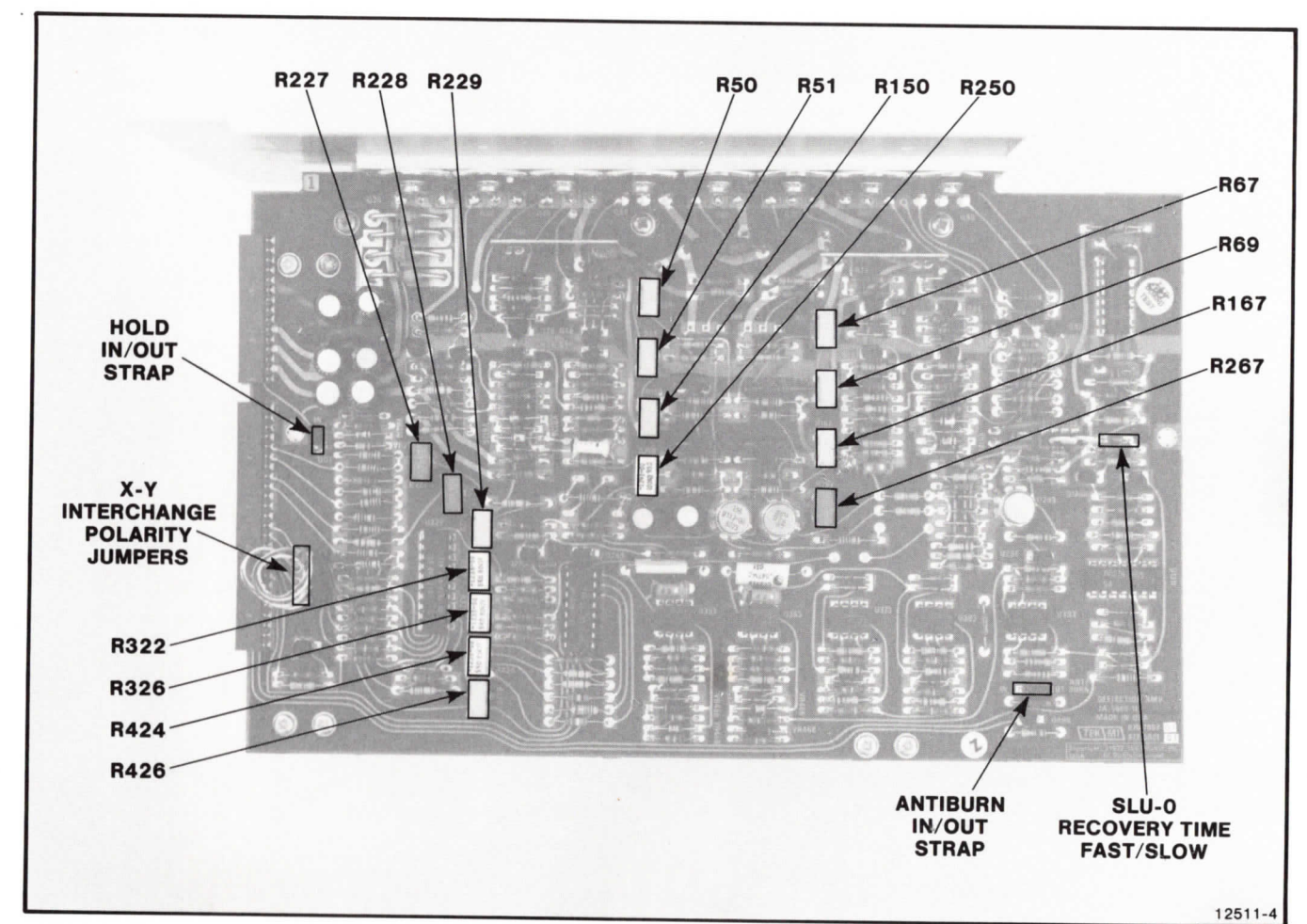

Figure 4-21. Deflection Amplifier Board-A15A1.

Section 5

SELF-TEST DIAGNOSTIC PROGRAM

INTRODUCTION

The primary troubleshooting aid for the 4114 is the Self-Test diagnostic program. This program resides in firmware and is arranged so it checks all hardware, starting with the initial error reporting mechanism (keyboard LEDs). Self-Test does not depend on any portion of the hardware until it has tested it; it may then use such hardware to aid in other tests.

PARTS OF SELF-TEST

There are three separate parts of the Self-Test program: the main Self-Test program, Power-Up, and Adjustment Self-Test. An additional diagnostic, System Errors Detector, is not really a part of Self-Test but is described in this section also. Figure 5-1 shows how these diagnostics are related to the main Self-Test firmware.

Power-Up

A subset of Self-Test is the Power-Up sequence. This diagnostic cannot be called directly by the user, but runs automatically each time the terminal is turned on. It performs a quick check of the various hardware modules. The 4114 operator's manual describes the error messages that may appear during the Power-Up sequence. For detailed diagnostic examination of terminal hardware, use Self-Test. Self-Test will perform additional tests as well as repeating the same tests that were done during the Power-Up sequence.

Main Self-Test

The main part of Self-Test is that portion which runs when the SELF TEST and MASTER RESET buttons are pressed. This routine repeats the Power-Up sequence and then goes on to thoroughly test the entire terminal hardware, including any options that may be installed.

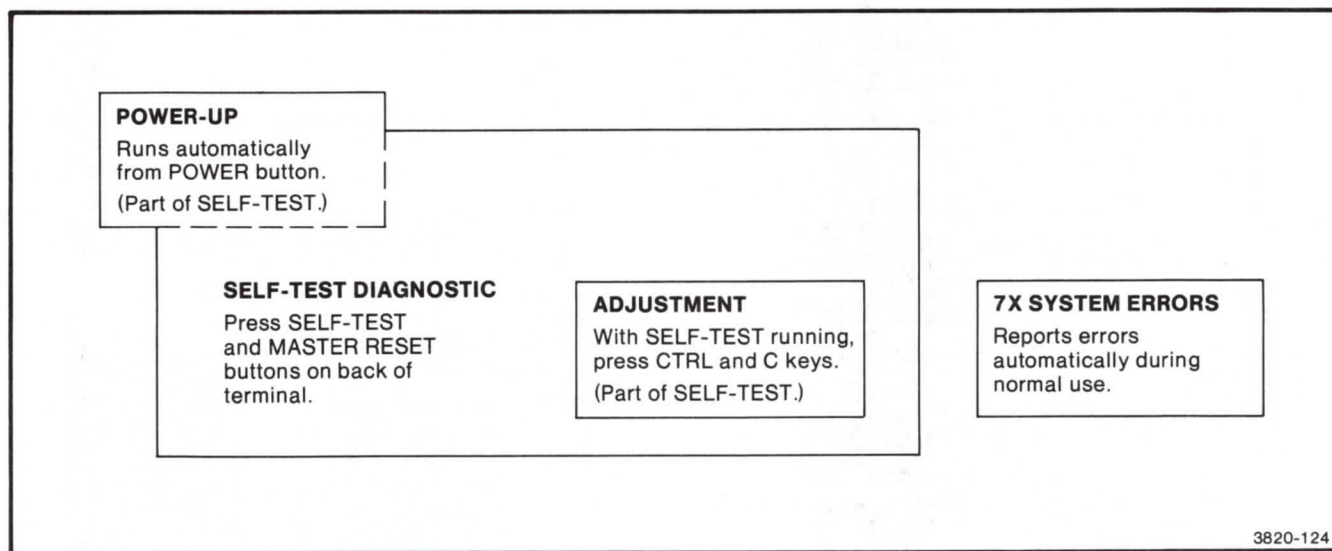

Figure 5-1. Self-Test Functional Diagram.

Adjustment Routine

The Adjustment part of Self-Test is used primarily for making adjustments and performance checks. However, this routine may also be used as a diagnostic tool, particularly on certain options such as the 3PPI. This routine is accessed from inside Self-Test by pressing the CTRL and C keys together. Detailed instructions about this part of Self-Test are located at the end of this section.

7x System Errors Detector

This error detecting firmware contains routines that catch system level or operator induced errors at the time they occur; not just during Self-Test. These error reporting routines are in ROM and have the same general syntax as the Self-Test error messages, but this error reporting device runs separately and independent of Self-Test. This allows it to report such errors spontaneously at the time a problem appears. The error codes that come under this category are listed and described in Table 5-11. If such an error is reported, which seems to be related to a hardware malfunction, run Self-Test to verify and locate it.

CONTROL FLOW OF SELF-TEST

Figure 5-2 shows the order in which the various hardware modules are tested. The three areas "flagged" with a 0 must function for Self-Test to run. After these areas are verified as functional, the keyboard lights and keys are tested (1). Then areas 2 through 9 are tested in that order.

Figure 5-7 (on the pull-out at the end of this section) shows the logical flow of Self-Test. This is the order in which the diagnostic checks are made when Self-Test is initialized. This figure does not include any sub-messages.

A subset of Self-Test is the Power-Up sequence. This sequence checks approximately 60% of the 4114 circuitry and is performed every time that the 4114 is turned on.

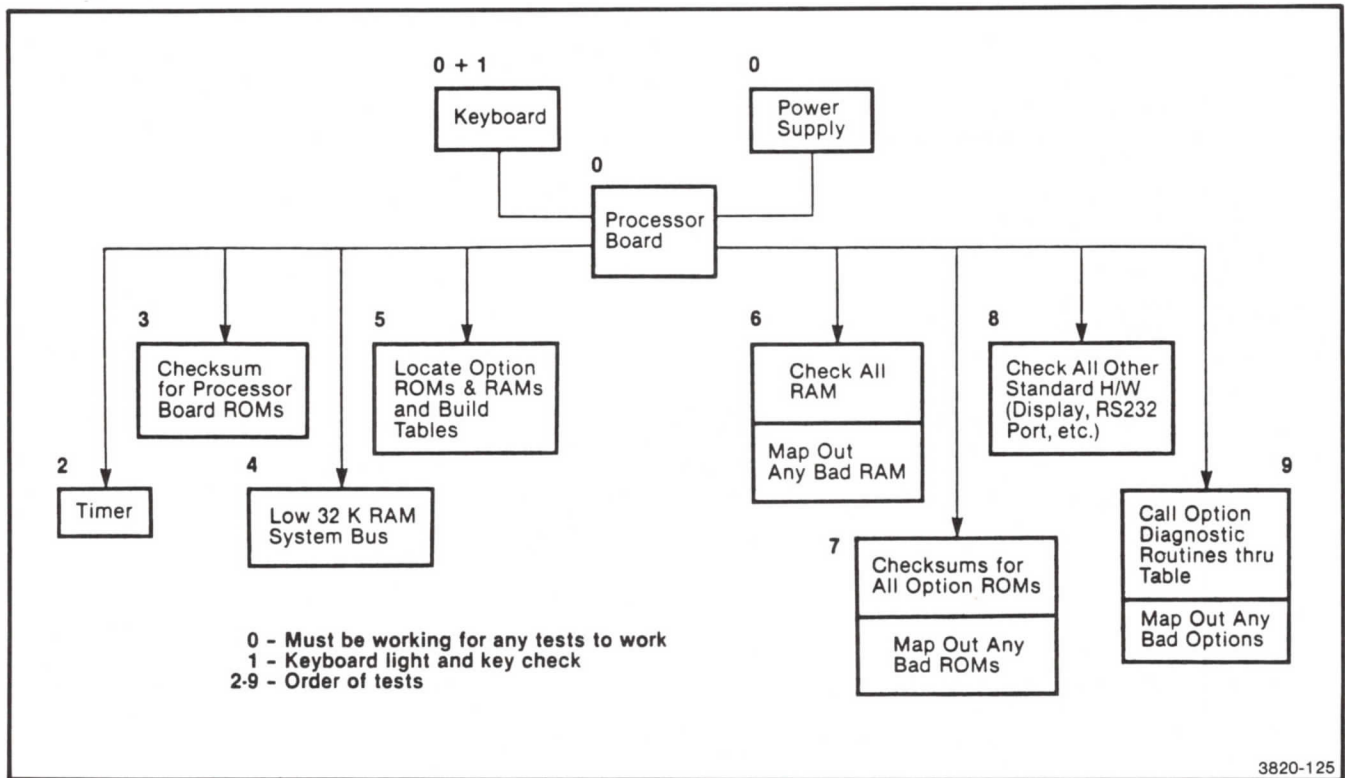

Figure 5-2. Self-Test Program Block Diagram.

In Table 5-1, the diagnostic checks that are performed during the Power Up routine are marked by the letters PUP. When the full version of Self-Test is run, all the tests are performed, including a repeat of the Power Up checks. This table contains only the tests executed by a standard 4114 terminal. The firmware used to check the options (such as the disk drive or Tablet Interface board) are contained on those optional boards.

NOTE

The light codes FD (1111 1101), CF (1100 1111), and BB (1011 1011) are not found in this table even though they are listed in the tables following. These codes are not tested in Self-Test, but are generated as error messages by the routine only if an error is found during the tests. For a definition of these codes, see the tables following Table 5-1.

Table 5-1
POWER-UP/SELF-TEST SEQUENCE

ERROR CODE		EXPLANATION	WHEN EXECUTED
Hex	Binary		
FE	1111 1110	Light checking routine	SLF
FC	1111 1100	Keyboard key check	SLF
EF	1110 1111	Timer check	SLF/PUP
EE	1110 1110	Timer set up routine	SLF/PUP
EC	1110 1100	Standard system ROM check	SLF/PUP
DF	1101 1111	Lowest 32K bus address check	SLF/PUP
BF	1011 1111	Lowest 32K RAM walking ones check	SLF
BE	1011 1110	Lowest 32K RAM walking zeros check	SLF
BD	1011 1101	Lowest 32K RAM all ones check	SLF/PUP
BC	1011 1100	Lowest 32K RAM all zeros check	SLF/PUP
B5	1011 0101	RAM stack building	SLF/PUP
BA	1011 1010	RAM/ROM memory tables building	SLF/PUP
DE	1101 1110	High address bus check	SLF/PUP

Table 5-1 (cont)
POWER-UP/SELF-TEST SEQUENCE

ERROR CODE		EXPLANATION	WHEN EXECUTED
Hex	Binary		
B9	1011 1001	Upper RAM walking ones check	SLF
B8	1011 1000	Upper RAM walking zeros check	SLF
B7	1011 0111	Upper RAM all ones check	SLF/PUP
B6	1011 0110	Upper RAM all zeros check	SLF/PUP
B4	1011 0100	System vector table expansion	SLF/PUP
FA	1111 1010	Keyboard identification set	SLF/PUP
CE	1101 1110	Processor ROM check	SLF/PUP
9F	1001 1111	Power Up/Reset	PUP
9E	1001 1110	Display/Display Control Test	SLF
9D	1001 1101	Display DMA/Vector Generator check	SLF
9C	1001 1100	Font initialization	PUP
AF	1010 1111	CMOS and ROM to RAM load	SLF/PUP
AF	1010 1111	CMOS and ROM to RAM load	SLF/PUP
EB	1110 1011	Interrupt checker	SLF/PUP
DD	1101 1101	Host port register checker	SLF/PUP
DC	1101 1100	Host port baud/character checker	SLF
CD	1100 1101	Option numbers checker	SLF/PUP
CC	1100 1100	Version compatability checker	SLF/PUP

SLF means the test is performed during Self-Test.
PUP means the test is performed during the Power-Up routine.

SELF-TEST FIRMWARE JUMP TABLE

To further aid in understanding how Self-Test works, refer to the ROM Header-Pointer diagram (Figure 5-3). This diagram shows how Self-Test is arranged around a "jump-table" system. This arrangement allows code updates and additions/deletions of option code sections to be mapped in or out easily.

HOW TO RUN SELF-TEST

Start Self-Test running by pressing the MASTER RESET and SELF TEST buttons. Press and hold MASTER RESET and SELF TEST, then release the MASTER RESET button. After the Keyboard LEDs begin to "cycle", release the SELF TEST button.

The test begins by turning on all the keyboard lights ("CAPS LOCK" key, four function key LEDs, and four indicator LEDs). The CAPS LOCK key light should turn off immediately (while the other eight LEDs remain lit). If the CAPS LOCK key light remains lit, there is a major malfunction in the processor.

While Self-Test is running, the eight keyboard lights blink through the codes for the various tests. When a fatal error occurs during a particular test, its identifying light pattern comes on blinking, and the bell will ring three times. These light patterns are displayed on the eight indicator LEDs, across the top of the keyboard¹. These light patterns indicate the binary equivalent of a hexadecimal code assigned to each major set of tests. The error message tables (in this section) list and define these error codes, giving an explanation for each error condition and suggesting which piece of circuitry malfunctioned. After the major error codes have been displayed, most problems can be narrowed down through the use of submessages. Submessages are displayed by first noting the major error codes, pressing RETURN, and noting the next set of lights displayed as the submessage. In some instances, there may be up to three levels of submessages.

After the display has been checked, most error messages are printed on the display screen. Such screen-displayed error messages first print the name of the test or the hardware module being tested. Then a submessage on the next line, tells which part of the test failed.

¹Eight LEDs, from KYBD LOCK light to the HARD COPY key light.

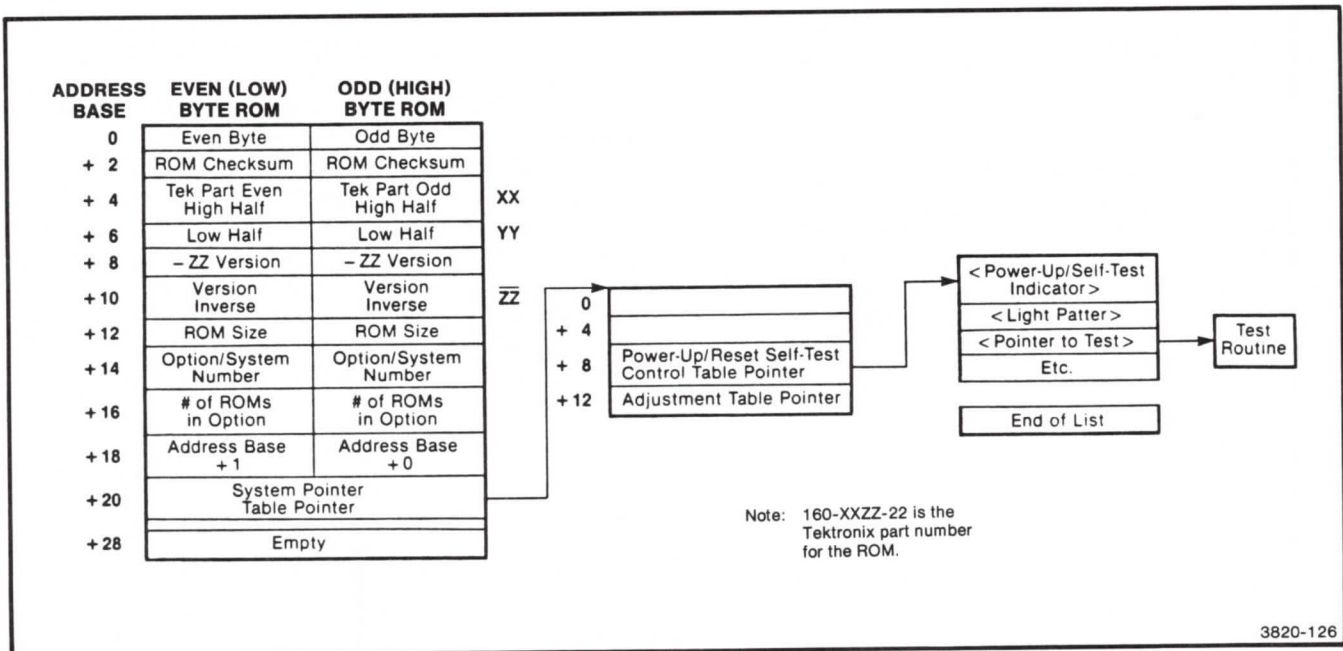

Figure 5-3. The ROM Header Contains a Chain of Pointers to Testing and Adjustment Routines That Are Executed Via Jump Tables.

SELF-TEST DIAGNOSTIC PROGRAM

Suppose Self-Test finds a major hardware problem that prevents the test from running to completion. Such is indicated by the light code for this test (where problem found) remaining lit indefinitely. This type of problem is highly unlikely, but could be caused by a bad ROM. Read the error code on the lights and use this to help determine where the test has aborted.

During the Delay Memory check (associated with Table 5-7, RAM Tests) there is a 14 second wait for each 32K of RAM being tested. In a fully loaded instrument (one with all RAM options installed), this test can take up to four minutes to run. Do not be surprised about this delay; it does not mean that Self-Test is "hung." If you wish to override this lengthy test, enter CONTROL D during the keyboard check and Self-Test will skip over this test.

SELF-TEST ERROR MESSAGES

This part of the section lists and describes the Self-Test error codes. In the following discussion, tests are grouped in modules according to the hardware being tested. Under each heading (test module name) is a short general description of the test and hardware it checks. Each table of error messages defines those messages that may appear while that test is running. To determine which piece of circuitry malfunctioned, read the list of active circuits for each test. Since many circuits are used in several tests, eliminate as "good" those circuits that passed all previous tests. These tables are grouped together for referencing convenience rather than the order in which the tests occur. Tables start with the error code FE (1111 1110) and are listed in descending order of the binary codes. Table 5-2 shows this order.

ERRORS DIRECTORY

Table 5-2 is a reference that shows which table to consult when any given error message is displayed. The Hex codes, in the center column, correspond to the light codes (displayed in binary on the LEDs) for each test category.

Keyboard Check and Lights (F)

When Self-Test starts, the indicator LEDs will show FF (1111 1111). As the test continues the light patterns approach 00.

During the keyboard lights check, each light is slowly turned on and off in a sequential loop beginning with the keypad, going across the eight LEDs (right to left), and down to the CAPS LOCK key. This circling light pattern is then repeated quickly.

At the beginning of the keyboard keys test the 4114 rings the bell once, and the CAPS LOCK key light starts blinking. This prompts the user to press a key (any key) after waiting a few seconds. When the bell rings and the CAPS LOCK key blinks, the test is supposed to stop and wait for a key stroke. If the test proceeds without pressing a key, this means spurious key strokes are being generated. This type of problem could be caused by dirt or corrosion in the keyboard, or a poor connection in the keyboard-to-processor board ribbon cable. If the test waits for a key entry, then press a key, allowing the tests to continue. Waiting too long before pressing a key causes the test to "time out" and continue (this usually takes about 20 seconds).

Table 5-2

SELF-TEST ERRORS DIRECTORY

TEST MODULE	HEX CODE(*)	TABLE NUMBER
KEYBOARD/PROCESSOR	Fx	5-3
PROCESSOR BOARD	Ex	5-4
RAM/BUS HOST PORT	Dx	5-5
SYSTEM OPTION ROMS	Cx	5-7
RAM TEST	Bx	5-8
CMOS MEMORY	Ax	5-9
DISPLAY BUS AND BOARD CHECK	9x	5-10
SYSTEM LEVEL ERROR CODES (**)	7x	5-11
3PPI (OPTION 10)		5-12
DISK (OPTION 42)		5-13
TABLET (OPTION 13/14)		5-14

(*) x Indicates this hexadecimal digit will change within the table.

(**) The 7x error codes are not part of Self-Test but are rather error codes that are generated if a problem occurs during normal use of the terminal. Self-Test does not have to be initialized to receive these error messages.

Table 5-3

KEYBOARD/PROCESSOR BOARD ERRORS

ERROR CODE		EXPLANATION
Binary	Hex	
1111 1110	FE	Error at beginning of keyboard lights test. (Circling lights test happens here.)
1111 1101	FD	Error at end of keyboard lights test.
1111 1100	FC	Error during keyboard keys test.
1111 1010	FA	Error while loading Keyboard Identification Code.

Submessage: (printed on screen)

"Keybrd -ID XX"

XX is the option number of the keyboard attached (example: a Swedish keyboard is Option 4C). This test then checks the validity of that Option number against the ROM Option number installed, and displays this message if the wrong ROMs or no ROMs (for the option) are present. See Figure 5-4 for the location of the keyboard ROMs.

"Keybrd -ID fail"

The identification test will fail when the 4114 cannot reset the keyboard and read the keyboard option number. This may be caused by a broken or loose connection.

CIRCUITS USED: Look for problems on Keyboard, Keyboard interface on the Processor Board, and keyboard ribbon cable and connectors.

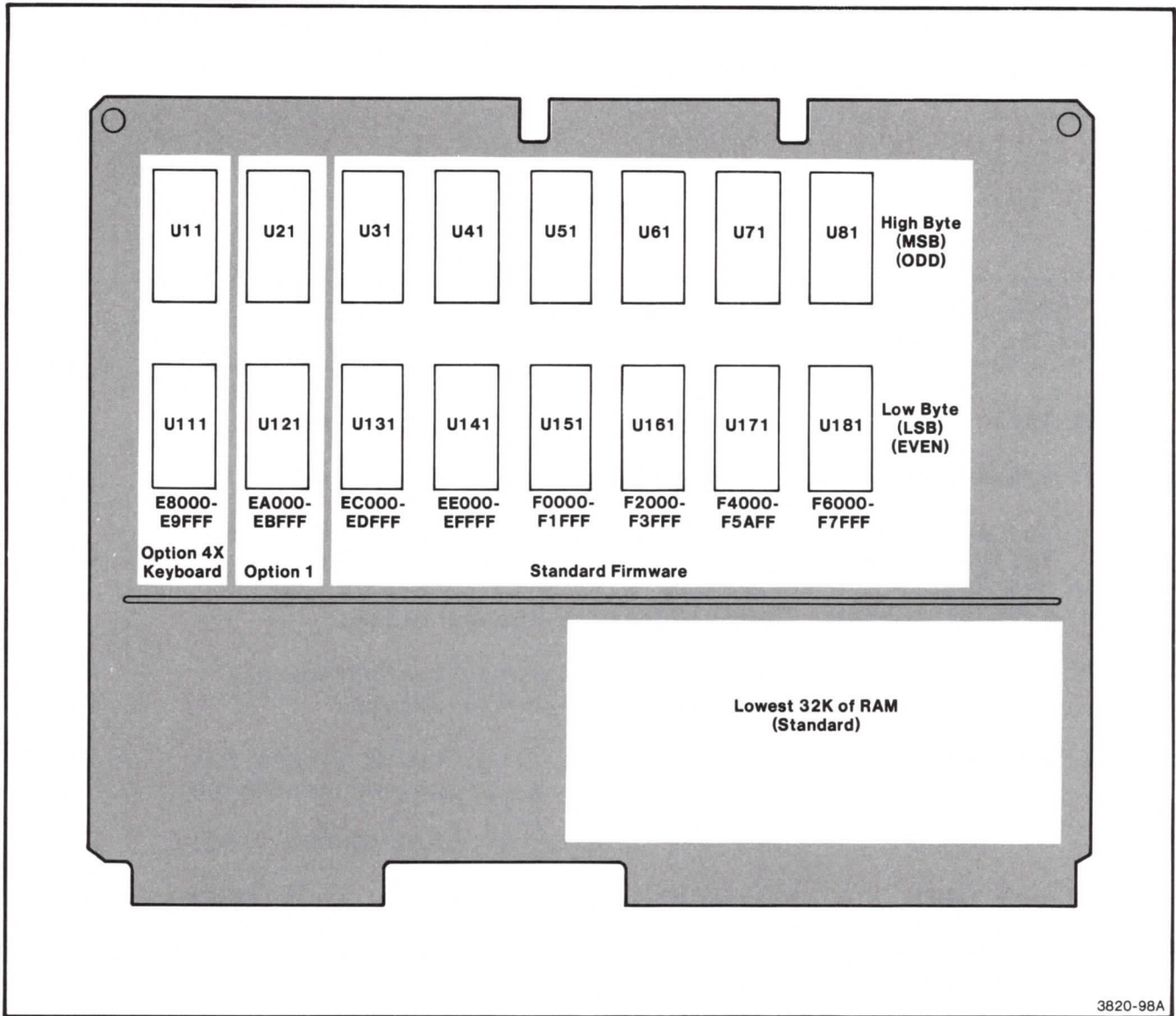

Figure 5-4. RAM/ROM Board.

Processor Check (E)

and its related hardware are systematically exercised.

At this time, Self-Test does a more thorough test of the Processor board and Keyboard functions. The processor

Table 5-4
PROCESSOR BOARD ERRORS

ERROR CODE Binary / Hex	EXPLANATION
1110 1111 EF	Error detected during Timer test. (a) Submessage: Bell; press RETURN, read light code. The submessage for the timer test will consist of the following parts: The highest four bits will be one of two codes, the lower four bits will be one of two possible codes. These codes are listed below.
0001 ----	Failed static test; tests timers' outputs for high/low values.
0010 ----	Failed dynamic test; tests timers for correct count vs. processor execution.
---- 0000	Failure in Timer 0 (I/O address 00E1).
---- 0001	Failure in Timer 1 (" " 00E3).

NOTE 2: Timer 2 cannot be tested at this point. It is checked later during the host port check.

Table 5-4 (cont)

PROCESSOR BOARD ERRORS

ERROR CODE		EXPLANATION
Binary	Hex	
1110 1110	EE	Failure during timer initialization.
1110 1100	EC	Error during standard ROM checksum test.
(a) Submessage 1: Bell; press RETURN, read light code.		
X X		Address of ROM problem in Hex XX000.
nnnn nnnn		(i.e., 1111 1110 = FE --> Address where problem found is FE000 'X'. This is first ROM pair on the Processor Board.) See Figure 5-5 for the location of the Processor board ROMs.
(a) Submessage 2: Bell, press RETURN again, read light code.		
This submessage consists of two parts, with the highest four bits consisting of one of three codes, and the lowest four bits of the message consisting of one of three possible codes. These codes are seen below.		
0001	----	ROM(s) not present.
0010	----	ROM(s) checksum error.
0011	----	Standard ROMs position check.
----	0000	xxxxxxxxxxxxxxxxxxxxxxxx
----	0001	Problem isolated to high ROM of pair.
----	0010	Problem isolated to low ROM of pair.
----	0011	Problem found in both ROMs of pair.

(a) Submessages are obtained in the following manner: When an error is noted, the bell will ring before each submessage. After noting the error bits (read from the keyboard LEDs), press RETURN, then read the submessage as the next set of lights displayed.

Table 5-4 (cont)
 PROCESSOR BOARD ERRORS

ERROR CODE Binary / Hex	EXPLANATION
1110 1011 EB	Error detected in Interrupt Handler Check
	Submessages: (printed on screen)
Interrupts-Static Error: XX	Bits that cannot be set in Interrupt Register (I/O base address 00EA).
Interrupts-Dynamic Address: XX	Level 5 interrupt performed. Failed to (b) reach interrupt vector address: XX + (4 x 5).
Interrupts-Div by 0 Address: XX	A divide by 0 instruction was performed, but did not vector through location 0. XX equals base interrupt address. (c)

CIRCUITS USED: Interrupts circuit block on Processor Board.

(b) Level five is the easiest level of interrupt to force (hence x5). Each time an increment of a level is made, it moves up four bytes in memory (hence the 4). XX equals the base interrupt address.

(c) This message with XXE00 most likely implies an earlier version of a 8086 processor chip not acceptable for Processor board operation.

NOTE 3: If either T1 or T2 inputs to the interrupt chip are stuck at a TTL low, Self-Test cannot detect this condition. Also, if an "interrupt level" output (from the interrupt chip) is stuck at a TTL low, Self-Test cannot detect this condition, either. If the interrupt chip seems to be causing a problem, examine the outputs with an oscilloscope, or replace the Processor board.

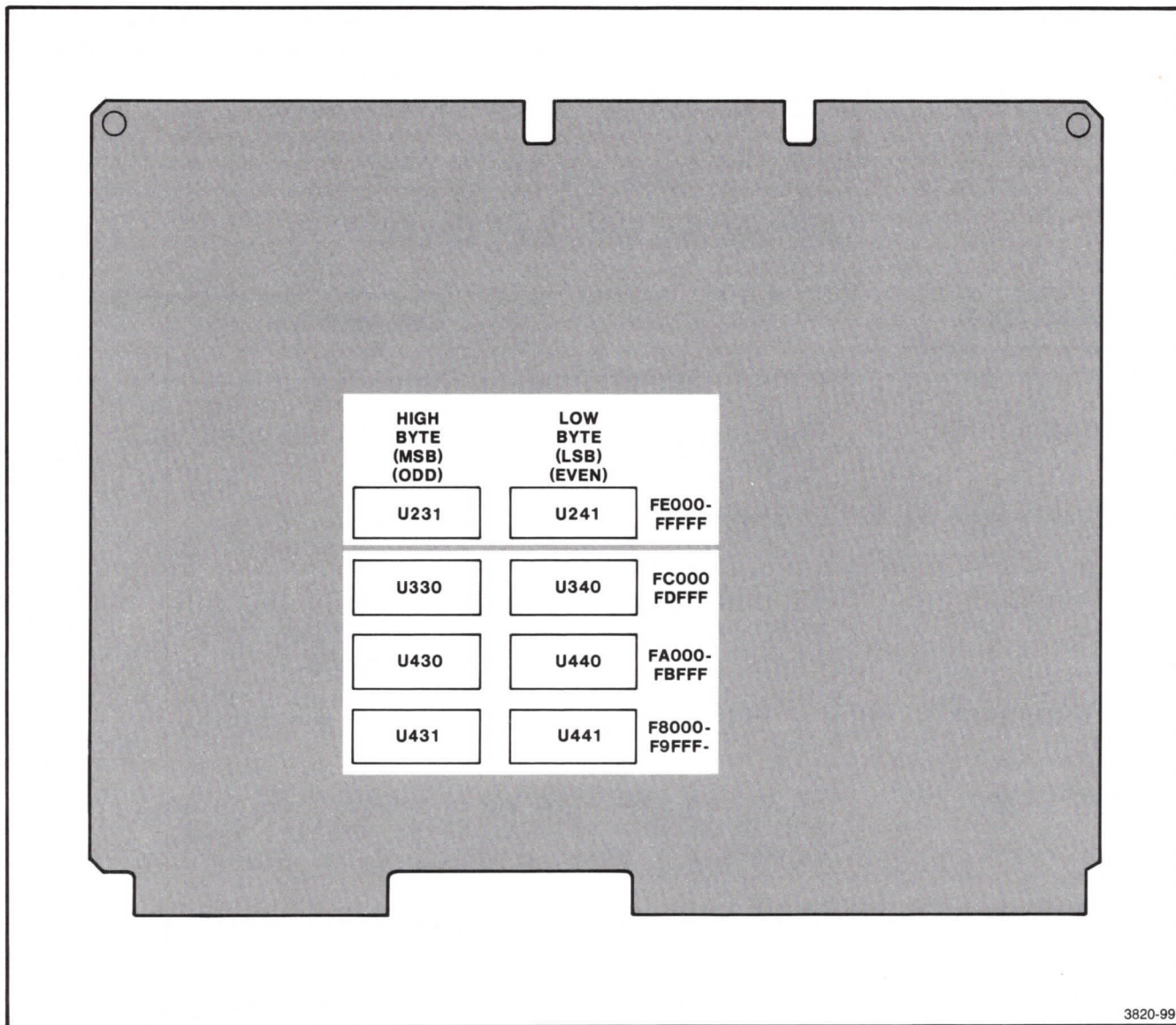

Figure 5-5. Processor Board ROMs.

SELF-TEST DIAGNOSTIC PROGRAM

Communications and Bus Checks (D)

This set of tests examines the operation of the main terminal bus and the host I/O port. This is accomplished

by writing its own address to low RAM (located between 0000 and 7FFF). It then reads this address back, using the comparison as a bus check. This assumes the RAMs are good.

Table 5-5

RAM/BUS AND HOST PORT ERRORS

ERROR CODE		EXPLANATION
Binary	Hex	
1101 1111	DF	Problems with low bits of main terminal bus or addressing via this bus. (a) Submessage 1: Bell, press RETURN, read light code. X X nnnn nnnn XX indicates the base address of the RAM that caused the bus problem: XX000 'X'. (i.e., 00 = 00000 and 20 = 20000.) (a) Submessage 2: Second Bell, press RETURN, read light code. Y Y nnnn nnnn YY is the Low data byte, showing which bits are in error. If these bits are all ones, address bit zero is likely to be bad. (a) Submessage 3: Third Bell, press RETURN, read light code. Z Z nnnn nnnn ZZ is the High data byte, showing which bits are in error. If these bits are all ones, byte high enable (BHEN) is probably bad. ----- NOTE: If YY and ZZ are all 1s, this indicates a time-out problem while attempting to access a RAM. -----

(a) Submessages 1 to 3: Bell rings before each submessage; after noting the error bits, press RETURN, read submessages as the next set of lights displayed.

Table 5-5 (cont)
 RAM/BUS AND HOST PORT ERRORS

ERROR CODE		EXPLANATION
Binary	Hex	
1101 1110	DE	Problem with the high bits of the main bus or addressing via this bus. Here it is writing high RAM (between 8000 and highest address) its address as data; then reading it back.
1101 1101	DD	Error detected during host port I/O address check
<p>Submessage: (printed on screen)</p> <p>"Host Port-Registers Expect: XX Receive: YY"</p> <p>This test checks the reset of the USART. After resetting USART, it reads the data at status I/O address: E2. It expects to read XX. If instead it receives YY (where XX not = YY) this means the test failed and the USART cannot be reset.</p> <p>"Host Port-Register Expect: XX-YY Receive: ZZ-AA</p> <p>The test checks USART Latch (I/O address EB), and USART Interrupt Request (" " EB).</p> <p>XX - Latch status expected; is 0 if no bits are in error.</p> <p>YY - Interrupt Request bits in error; is 0, if no bits are in error.</p> <p>ZZ - Latch Status bits in error.</p> <p>AA - Interrupt Request bits in error.</p>		

Table 5-5 (cont)
RAM/BUS AND HOST PORT ERRORS

ERROR CODE		EXPLANATION
Binary	Hex	
1101 1100	DC	Error detected during host port baud rate/character check
<p>Submessage: (printed on screen)</p> <p>"Host Port-Baud/Character Baud: XXXX Expect: YY-AA Receive: ZZ-BB"</p> <p>XXXX - Baud rate in hex (see Table 5-6). YY - character sent. AA - USART data status bits in error; expect 00 (I/O address E4). See Figure 5-6. ZZ - character received. BB - USART Data Status bits in error.</p>		

CIRCUITS: All RAM locations 0000 to 7FFF and 8000 to top RAM address bus lines connecting Processor and RAM/ROM board.

NOTE 4: Self-Test cannot check the following signals if they are tied to a TTL low: MWTC; PFAIL; BCLK; INT1; INT2; INT3; INT4; INT6; INT7; BREQ; and BGT.

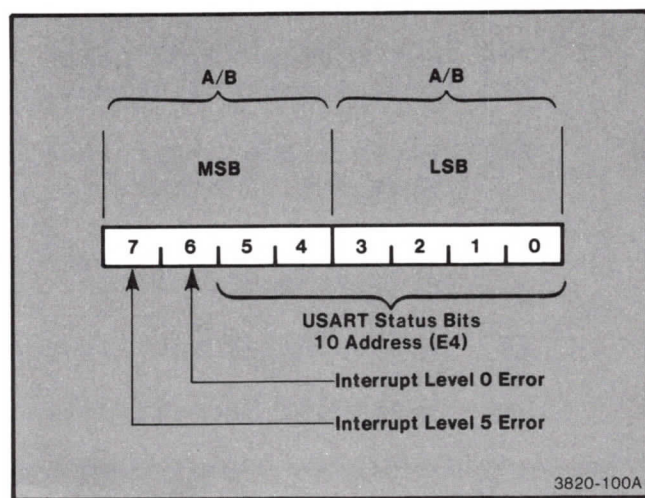

Figure 5-6. Status Byte.

The following table may be used to convert Hex numbers received into decimal numbers.

Table 5-6
HEX-TO-DECIMAL EQUIVALENTS

HEX NUMBER	DECIMAL NUMBER
12C	300
258	600
4B0	1200
708	1800
7D0	2000
960	2400
E10	3600
12C0	4800
1C20	7200
2580	9600
4B00	19200
9600	38400

Memory Tests

ROM Check (C). This set of tests examines the operation of all ROMs on the RAM/ROM board and all

option ROMs. The ROMs on the Processor board were tested along with the processor in previous tests. For the locations of the bad ROMs on the RAM/ROM board, refer back to Figure 5-4.

Table 5-7
SYSTEM/OPTION ROMS ERRORS

ERROR CODE Binary / Hex	EXPLANATION
1100 1111 CF	Failure during ROM Map generation.
1100 1110 CE	Error found during ROM checksums test.
Submessages:	Error messages are same as for main ROMs; see Table 5-4.
1100 1101 CD	ROMs found in wrong position (options only).
Submessages: (Displayed on screen)	
"ROM-Position Address: XXXX Expect: YY-ZZ Receive: AA-BB" ROM Set: CC-Fail	<p>Address XXXX -- the base address of the ROM pair being checked. See NOTE 1, below.</p> <p>Expect YY-ZZ -- 1) YY is the ROM Set number (same as option number. 2) ZZ indicates even or odd ROM of pair. (If ZZ is odd, then odd ROM is problem; if ZZ is even, then even ROM is problem).</p> <p>Receive AA-BB -- found ROM Set number AA (instead of YY); BB (like ZZ) indicates odd vs. even of pair.</p> <p>ROM Set CC-Fail -- CC is option (ROM Set) number of ROM that failed.</p>

NOTE 1: If FFFF, then Self-Test could not find the ROM pair indicated by "Expect: YY-ZZ".

Table 5-7 (cont)
 SYSTEM/OPTION ROM ERRORS

ERROR CODE		EXPLANATION	
Binary	Hex		
1100	1101	CD	(cont) ROMs in wrong position. Example> Address: 1600 Expect: 42-17 Receive: 42-15 ROM Set: 42-Fail Means -- that the base address of the ROM pair being checked is 16,000. 42 is the ROM set number expected (disk). 17 is base address + 1 (odd ROM of pair). If 16 is base address + 0 (even ROM " "). The test found 42-15 at the address; 42 was the ROM Set, and 15 means the odd ROM for location 14,000 was found there (instead of odd ROM for 16,000).
1100	1100	CC	ROM version compatibility problem Submessage: (printed on screen) "ROM-Version ROM Set: XX-VV Expect: YY-ZZ Receive: AA-BB ROM Set: CC-Fail" ROM Set used for reference is XX (see NOTE 2), and its version number is VV. "Expect YY-ZZ" refers to the expected ROM option name YY, and version number ZZ for the ROM Set being checked. "Receive AA-BB" reports the actual ROM name (AA) and version (BB) in same socket. Example> ROM Set: 00-05 Expect: 42-03 Receive: 42-01 Means -- The main system firmware (called 00) is version 5. It expects Option 42 ROMs with version 3 or higher to be installed. Instead, it finds Option 42 ROMs, with only version 1 firmware, installed. ROM Set: CC-Fail ROM failure -- CC is number of Option where version problem appeared. This ROM set is mapped out of the option.

CIRCUITS USED: RAM/ROM Board ROMs and circuits, and ROMs on option boards.

NOTE 2: XX is option number. System ROMs number is always 00.

SELF-TEST DIAGNOSTIC PROGRAM

RAM Check (B). This series of tests perform a systematic check of all system RAMs. Each set of tests are grouped, and each such group uses the same type of error reporting scheme (light codes). Refer back to Figure 5-4, which shows the physical location of the lowest 32K of RAM.

In the following tests, the RAM Memory Delay Check (BB) generates a light code which may remain lit for as much as 14 seconds while the test is running. This does not indicate an error. An error is indicated by a bell accompanied by a light code which stays on indefinitely. The lengthy Delay Memory Check may be overridden by entering CONTROL D during the keyboard check.

NOTE

In the following table, "Lowest 32K RAM" refers to the RAM from hexadecimal address 0000 to 7FFF, or the standard RAM of the 4114. "Upper RAM" refers to any extended RAM options installed in the 4114, starting at hexadecimal address 8000.

Table 5-8
RAM TEST ERRORS

ERROR CODE Binary / Hex	EXPLANATION
1011 1111 BF	Lowest 32K of RAM, walking ones check. (Here each bit is set and tested, in order from left to right, hence the "walking ones" term." This light code is accompanied by one of the following light code submessages.
(a) Submessage 1: Bell rings, press RETURN, read light code.	
X X nnnn nnnn	XX indicates the address of the RAM problem at XX000 'X'.
(a) Submessage 2: Second bell, press RETURN, read light code.	
Y Y nnnn nnnn	YY is the Low Data byte, showing which bits are in error.
(a) Submessage 3: Third bell, press RETURN, read light code.	
Z Z nnnn nnnn	ZZ is the High Data byte, showing which bits are in error.

Table 5-8 (cont)

RAM TEST ERRORS

ERROR CODE		EXPLANATION
Binary	Hex	
1011 1110	BE	(b) Error in "walking zeroes check;" lowest 32K RAM.
1011 1101	BD	(b) Error in "all ones check;" lowest 32K RAM.
1011 1100	BC	(b) Error in "init (zero check);" lowest 32K RAM..
1011 1011	BB	(b) Error in "RAM memory delay check." During the RAM memory delay check, data is held for 14 seconds and then rechecked. The light code will remain lit for this time.
1011 1010	BA	"RAM Memory Map Generation" error. This test checks for RAM and the absence of RAM and generates a corresponding memory map.
1011 1001	B9	(b) Error in "walking ones check;" upper RAM.
1011 1000	B8	(b) Error in "walking zeroes check;" upper RAM.
1011 0111	B7	(b) Error in "all ones check;" upper RAM.
1011 0110	B6	(b) Error in "init (zero check);" upper RAM.
1011 0101	B5	Error during RAM stack building.
1011 0100	B4	Error in operating system vector table (lowest 32K of RAM)

(a) Submessages are obtained in the following manner: when an error is noted, the bell will ring. After noting the error bits (read from the Keyboard LEDs), press RETURN, then read the submessage as the next set of lights displayed.

(b) If one of these messages is displayed as an error (the bell rings), the three submessages earlier in the table will have to be read in order to locate the problem.

SELF-TEST DIAGNOSTIC PROGRAM

CMOS Check (AF). When a CMOS memory error is detected, the LEDs will show the "AF" pattern (1010 1111), and a message is written on the display screen. The only time a full CMOS check is performed is during the Adjustment Procedure. See Processor Board menu at the end of this section.

NOTE

The following CMOS error messages report a change in default parameters. This may be caused by either: changing EPROMs, or by a CMOS battery/circuit failure.

Table 5-9
CMOS MEMORY ERRORS

ERROR CODE Binary / Hex	EXPLANATION
1010 1111 AF	CMOS check
Submessage: (printed on screen)	
"Cmos-Error	
I/O Address: XXXX Expect: YY41 Receive: ZZZZ	
	XXXX = Address of problem. If it is addressing correctly, the address will read FFFE.
	YY41 = YY is the system version number (taken from EPROM) and 41 indicates 4110 series product.
	ZZZZ = this is what is actually read, instead of YY41.
"Cmos-Checksum"	Checksum error detected.
"Setup Default-Reset"	CMOS parameters have been updated. This is the same as the Power-up message.

DISPLAY TESTS (9)

The Self Test program tests the two circuit boards that control how information is displayed on the display module screen: the Display Controller and Vector Generator boards. This set of tests also determines whether the display module is functioning, but does not isolate problems to individual boards or circuits in the display module.

If the Direct Memory Access (DMA) controller is malfunctioning, it can "hang" the system bus. If this happens, the processor will not be able to access the display test code. The terminal will then appear to "hang" on one of the light codes shown in Table 5-10.

Table 5-10

DISPLAY CONTROLLER, VECTOR GENERATOR, AND DISPLAY MODULE ERRORS

ERROR CODE Binary / Hex	EXPLANATION
1001 1111 9F	4114 Power Up/Reset Check
(a) Submessage 1: Bell, press RETURN, read light code:	
0000 0001	Display Module
0000 0010	Vector Generator
0000 0011	Display Module or Vector Generator
0000 0100	Display Controller
0000 0101	Display Module or Display Controller
0000 0110	Display Controller or Vector Generator
0000 0111	Cannot isolate problem
If 0001 appears as the four most significant bits (leftmost), A fatal error is indicated--these circuits will not work at all or will always generate errors.	

Table 5-10 (cont)

DISPLAY CONTROLLER, VECTOR GENERATOR, AND DISPLAY MODULE ERRORS

ERROR CODE		EXPLANATION	I/O Port Read	Bit Checked (b)
Binary	Hex			
(a) Submessage 2: Bell, press RETURN, read light code:				
<u>Error Code</u>		<u>Explanation</u>	<u>I/O Port Read</u>	<u>Bit Checked (b)</u>
0000 0001		No I/O port D0 read	D0	0-15
0000 0010		Vector in progress (bit active)	D0	3
0000 0011		Display list in progress (bit active)	D0	0
0000 0100		No I/O port D2 read	D2	0-15
0000 0101		SLU bit active	D2	11
0000 0110		Z bit active	D2	13
0000 0111		Long jump latch active	D2	9
0000 1000		Long vector latch active	D2	8
0000 1001		Generator running active	D2	2
0000 1010		Vector available active	D2	1

Note that these light codes are in consecutive binary order. This is the order in which the tests are done. Thus, if the light code 000 0111 appears, for example, all of the tests previous to this have been done and are functioning.

(a) Submessages are obtained in the following manner: When an error is noted, the bell will ring. After noting the error bits (read from the keyboard LEDs), press RETURN, and read the submessage as the next set of lights displayed.

(b) The 0 bit is the least significant bit (rightmost) and the 15 bit is the most significant bit.

Table 5-10 (cont)

DISPLAY CONTROLLER, VECTOR GENERATOR, AND DISPLAY MODULE ERRORS

ERROR CODE		EXPLANATION
Binary	Hex	
1001 1110	9E	Display Check Display Controller Check
(a) Submessage 1: Bell, press RETURN, read light code.		
0000 0001		Display Module
0000 0010		Vector Generator
0000 0011		Display Module or Vector Generator
0000 0100		Display Controller
0000 0101		Display Module or Display Controller
0000 0110		Display Controller or Vector Generator
0000 0111		Cannot isolate problem
If 0001 appears as the four most significant bits (leftmost), this indicates a fatal error. These circuits do not work at all or always generate errors. The terminal hangs with flashing lights.		
(a) Submessage 2: Bell, press RETURN, read light code.		

Table 5-10 (cont)

DISPLAY CONTROLLER, VECTOR GENERATOR, AND DISPLAY MODULE ERRORS

ERROR CODE		EXPLANATION	I/O Port Read	Bit Checked
Binary	Hex			
0000	0001	No I/O port D2 read	D2	0 - 15
0000	0010	DBUSY active after View mode is reset	D2	10
0000	0011	Ready for command bit not active	D0	1
0000	0100	Long jump latch won't set	D2	9
0000	0101	Long jump latch won't reset	D2	9
0000	0110	Long vector latch won't set	D2	8
0000	0111	Long vector won't reset	D2	8
0000	1000	No DBUSY response to erase command	D2	10
0000	1001	DBUSY on after erase	D2	10
0000	1010	X12 won't load to 0	D2	5
0000	1011	Y12 won't load kto 0	D2	4
0000	1100	X12 won't load to 1	D2	5
0000	1101	Y12 won't load to 1	D2	4
0000	1110	Vector execution not started	D0	3
0000	1111	Relative move execution took too long	D0	3
0001	0000	Relative move execution not completed	D0	3
0001	0001	X12 not 1: 0-4095 (1)	D2	5
0001	0010	Y12 not 1: 0-4095 (1)	D2	4
0001	0011	X12 not 0: 4095-4096 (1)	D2	5
0001	0100	Y12 not 0: 4095-4096 (1)	D2	4
0001	0101	X12 not 0: 8091-4096 (1)	D2	5
0001	0110	Y12 not 0: 8091-4096 (1)	D2	4

Table 5-10 (cont)

DISPLAY CONTROLLER, VECTOR GENERATOR, AND DISPLAY MODULE ERRORS

ERROR CODE		EXPLANATION	I/O Port Read	Bit Checked
Binary	Hex			
0001	0111	X12 not 1: 4096-4095 (1)	D2	5
0001	1000	Y12 not 1: 4096-4095 (1)	D2	4
0001	1001	X12 not 1: 4032-4095 (1)(2)	D2	5
0001	1010	Y12 not 1: 4032-4095 (1)(2)	D2	4
0001	1011	X12 not 0: 4095-4096 (1)(2)	D2	5
0001	1100	Y12 not 0: 4095-4096 (1)(2)	D2	4
0001	1101	MX11 stuck high	D2	3
0001	1110	MY11 stuck high	D2	0
0001	1111	MX11 stuck low	D2	3
0010	0000	MY11 stuck low	D2	0
0010	0001	4095 stored vector too fast (<2.0 ms)	D2	1
0010	0010	4095 stored to slow (>3.0 ms)	D2	1
0010	0011	Vector clipping failure	D2	1
0010	0100	Refresh vector too slow	D2	1
0010	0101	Dot dash not working	D2	1
0010	0110	Speed compensation failure	D2	1
1001	1101	9D	Display DMA check Vector Generator board	
(a) Submessage 1: Bell, press RETURN, read light code.				
0000	0001	Display Module		
0000	0010	Vector Generator		
0000	0011	Display Module or Vector Generator		
0000	0100	Display Controller		
0000	0101	Display Module or Display Controller		
0000	0110	Display Controller or Vector Generator		
0000	0111	Cannot isolate problem		

SELF-TEST DIAGNOSTIC PROGRAM

Table 5-10 (cont)

DISPLAY CONTROLLER, VECTOR GENERATOR, AND DISPLAY MODULE ERRORS

ERROR CODE	EXPLANATION
Binary / Hex	
<hr/>	
If 0001 appears as the four most significant bits (leftmost), this indicates a fatal error. These circuits do not work at all or always generate errors. The terminal hangs with flashing lights.	
(a) Submessage 2: Bell, press RETURN, read light code.	
0000 0001	Long Jump does not work
0000 0010	Scaling displacement failure
0000 0011	Time too short on timing test
0000 0100	Time too long on timing test
0000 0101	Display Controller not ready
1001 1100 9C	Character Font Initialization

CIRCUITS: Replace Vector Generator or Display Controller boards. Check bus connection and cable connection to display module. Check Display Module.

(a) Submessages are obtained in the following manner: when an error is noted, the bell will ring before each submessage. After noting the error bits (read from the keyboard LED's), press RETURN, then read the submessage as the next set of lights are displayed.

- (1) These numbers correspond to the X or Y Display Address Counters. The first number is the starting address during the test and the second is the ending address during the test (see submessage 2 under the error code 9E, located on the previous page).
- (2) Short vector format was used (see submessage 2 under the error code 9E, located on the previous page).

SYSTEM LEVEL ERRORS (7X)

These error messages prompt the user whenever the specified problem occurs. These error codes may appear at any time: NOT just during Self-Test. When

such an error message appears, run Self-Test to locate any defective circuitry that may be involved. Most of these errors involve improper use of the terminal and are referred to as "system level" errors, rather than hardware errors.

Table 5-11

SYSTEM LEVEL (7x) ERROR CODES

ERROR CODE		EXPLANATION
Binary	Hex	
0111 1111	7F	CMOS memory lacking Could not get enough memory for system initialization. Try resetting CMOS parameters.
0111 111	7E	No monitor level procedure. A monitor procedure was called from an interrupt service routine (ISR). This error should only happen when a file is downloaded containing software ISRs.
0111 1101	7D	System data structures scrambled- RAM data lost. Try resetting the terminal or checking any routines created in the terminal or loaded into the terminal that may be writing into the wrong area.

Table 5-11 (cont)
 SYSTEM LEVEL (7x) ERROR CODES

ERROR CODE Binary - Hex	EXPLANATION
0111 1100 7C	<p>Unexpected or illegal interrupt.</p> <p>If this error code is generated, it is suggested that Self-Test be run to pinpoint the interrupt failure area. Note: could spurious interrupt have been generated by operator?</p>
0111 1011 7B	<p>Error Handler could not set dynamic memory for an error message.</p> <p>Check the user allocation of RAM through the STA MEM (status memory) command for available memory.</p>

4114 OPTION TESTS AND ERROR MESSAGES

Self-Test is extended to three options that can be installed in the 4114. Options 42/43 (one or two disk drives) require a Disk Controller board. This circuit board contains ROMs which allow it to test itself when Self-Test is run. Likewise, the 3PPI board and Tablet Interface board (options 10 and 13/14 respectively) also contain ROMs which allow these circuit boards to test themselves when Self-Test is run. Options 24 through 29 (extended RAM options) are also checked during Self-Test, but by the normal firmware, and not by firmware in ROMs on the RAM boards. RAM above the standard 32K bytes is noted as 'Upper RAM' in the RAM test (located earlier in this section).

Error messages for the 3PPI board, Disk Controller board, and Tablet Interface board are the same for both the 4112 and 4114 terminals, since these boards are interchangeable in both terminals.

3PPI Board Tests

These error codes may appear while running Self-Test, only if the 3PPI Option is installed and the host port cables are in use. For a 3PPI cable testing procedure, go to the "3PPI Adjustment Menu/Procedure" at the end of this section.

Table 5-12

3PPI ERRORS

ERROR CODE Binary / Hex	EXPLANATION
0110 1111 6F	Error detected during Register check.
	Submessage:(printed on screen)
	I/O Address: FBnn Expect WW-XX Receive: YY-ZZ
	Explanation: The information reported by this error code is interpreted as follows: nn = register in error WW = expected data YY = actual data ZZ = actual interrupt

Table 5-12 (cont)

3PPI ERRORS

ERROR CODE			EXPLANATION
Binary	/	Hex	

0110	1110	6E	Error detected during 3PPI Character check.
------	------	----	---

Submessage (printed on screen):

```
3PPI Baud/Character
Baud: nnnn Expect: WW-XX
Receive: YY-ZZ
```

Explanation: nnnn = Baud rate (Hex).
 WW, XX, YY, ZZ are explained under the
 6F error message.

The following error messages may also appear on the screen.

3PPI Baud/Character	This means that no character data
Baud: nnnn Expect: 00-02	is received.
Receive: 00-FF	

3PPI Baud/Character	This means that there is a data
Baud: nnnn Expect: FF-00	transmission error where nn was
Receive: nn-00	was the character sent.

The Character check test uses internal loop-back testing. There is no interaction between this test and external equipment. The equipment is operation at either the system preset rate or 1200 baud, whichever is higher.

NOTE 7: Refer the table earlier in this section to convert the hexadecimal numbers received into decimal numbers.

Option 42/43 Self-Test Error Messages. Start the program running in the same manner as the normal Self-Test (by pushing the SELF TEST and MASTER RESET keys in the proper succession).

NOTE

Do NOT insert or remove a disk while Self-Test is running as this will generate unexpected interrupts.

Table 5-13
DISK OPTION ERRORS

ERROR CODE		EXPLANATION
Binary	Hex	
0101 1111	5F	Board Status Register Check
<p>This test validates the operation of the hardware comprising the Board Status Register (at X'FC00'). Each Read/Write bit in the register is set (set=0) and tested; it is again reset and tested.</p> <p>Submessage: (printed on screen)</p>		
"Disk - Board Status Register"		These tests check each bit in the BSR (Board Status Register).
"Disk - ADR19-1 not = 0"		Wrote a 0 to ADR19 (D3 of FC01) and read back a 1.
"Disk - ADR19-1 not = 1"		Wrote a 1 to ADR19, but read back a 0
"Disk - ADR19-1 not reset, =1"		Wrote a 0 to reset ADR19, but read a 1.
"Disk - INTE-0 not working"		Did not read back what was written at D6.
"Disk - BUSW-0 not working"		Did not read back what was written at D5.
"Disk - HDL3-0 not working"		Did not read back what was written at D3.

NOTE 8: The first three submessages listed check the ADR19 Address Counter.

Table 5-13 (cont)
DISK OPTION ERRORS

ERROR CODE Binary / Hex	EXPLANATION
"Disk - HDL2-0 not working"	Did not read back what was written at D2.
"Disk - HDL1-0 not working"	Did not read back what was written at D1.
"Disk - HDL0-0 not working"	Did not read back what was written at D0.

Circuits used: Address Decode, Input Data Buffer, and Board Status Register.

0101 1110 5E Initialize and check Disk Controller

The FDC is put into its command phase (regardless of its present state) via a series of command reads and writes. The following bits are tested for correct state:

- Under X'FC00' -- D7 (EOC-1)
- Under X'FC0B' -- D7 (RQM-1) and D6 (DIO-1).

A SPECIFY command is then issued by the processor.

Submessages: (printed on screen)

- "Disk - Controller Protocol"
- "EOC-0 is 0 after init" FDC generates an unexpected interrupt, bit is in wrong state after initialization.
- "Disk - DIO-1 is 0 - Write required" FDC required a write to it, while processor expects to read from it.

Table 5-13 (cont)
DISK OPTION ERRORS

ERROR CODE Binary / Hex	EXPLANATION
"Disk - DIO-1 is 1 - Read required"	FDC requires a read from it, but processor expects to write to it.
"Disk - DIO-1 is 1 after init"	Bit D6 is in wrong state after initialization.
"Disk - RQM-1 remains 0"	FDC never sends RQM-1 (fails in 1000 tries).
"Disk - Cannot restore Protocol"	Runs initialization sequence, but cannot put FDC into a known state. (Processor has no idea what FDC is doing).

Circuits used: FDC, Board Status, Control Strokes, Data MUX, and Address Decode.

0101 1101 5D Drive present check

The processor issues a SENSE DRIVE 0 STATUS (SDS) command. Drive 0 should be present. The D7 (RQM-1) and D6 (DIO-1) are tested for correct states before and during the command.

Submessage: (printed on screen)

"Disk- F0: not present" Drive 0 should always be present. This message means the FDC or Disk Drive control cannot find drive unit 0.

Circuits used: FDC's disk control I/F, and Disk Drive Control circuits.

Table 5-13 (cont)
DISK OPTION ERRORS

ERROR CODE Binary / Hex	EXPLANATION
0101 1100 5C	Intersystem Interrupt check
<p>The following procedure is used to generate an interrupt: The heads are unloaded (should already be unloaded from last test), and the processor issues a RECAL DRIVE 0 command. Recal is executed, but the head does not move. The FDC does not know that the heads were unloaded, so it generates an interrupt. An error is also reported, unless head was already at Track 0.</p> <p>The processor then issues the SENSE INTERRUPT STATUS (SIS) command to read the results of the RECAL command. The results of the SIS command are checked as well as RQM-1 and DIO-1.</p> <p>Submessages: (printed on screen)</p> <p>"Disk - Intersystem Interrupt Check"</p> <p>"Disk -Bad FC00 init" Board Status Register contains error (different state than expected).</p> <p>"Disk -Bad FC08 init" FDC status register contains an error (different state than expected).</p> <p>"Disk -Bad FC00 RECAL-1 status" Error in Board Status Register (BSR) after first byte of RECAL command written.</p> <p>"Disk -Bad FC08 RECAL-1 status" Error in FDC after first RECAL byte written.</p> <p>"Disk -Bad FC00 RECAL-2 status" Error in BSR after second RECAL byte written.</p> <p>"Disk -Bad FC08 RECAL-2 status" Error in FDC after second RECAL byte written.</p> <p>"Disk -Level 7 interrupt not present" Expected interrupt not present.</p>	

Table 5-13 (cont)

DISK OPTION ERRORS

ERROR CODE Binary / Hex	EXPLANATION
"Disk -Bad FC00 SIS status"	Error in BSR after Sense Interrupt status byte written.
"Disk -Bad FC08 SIS status"	Error in FDC after Sense Interrupt status byte written.
"Disk -ST0 data error"	Error in ST0, read at FDC.
"Disk -Bad FC00 ST0 status"	Error in BSR after ST0 status byte read.
"Disk -Bad FC08 ST0 status"	Error in FDC after ST0 status byte read.
"Disk -Track error"	Error in track number (PCN), read at FDC.
"Disk -Bad FC00 Track status"	Error in BSR after track number read.
"Disk -Bad FC08 Track status"	Error in FDC after track number read.
"Disk -Level 7 interrupt still present"	Interrupt still present.
Circuits used: Address Decode, Board Status, Control Strokes, Data MUX, and FDC.	

Table 5-13 (cont)
DISK OPTION ERRORS

ERROR CODE Binary / Hex	EXPLANATION
0101 1011 5B	DMA Operation check
Submessage: (printed on screen)	
"Disk - DMA transfer failed"	Data ('80') not found at current DMA address (RAM only).
Circuits: DMA State Machine, Data MUX, Control Strokes, Address Decode, Address Counters, Input Data Buffers, and Board Status blocks.	
0101 1010 5A	DMA addressing check
Both this test and the previous test must be completed before the DMA State Machine and the DMA Address Counters are fully tested; the testing of one requires the operation of the other.	
The DMA Address Counters are write only. The only way to look at these counters is to examine the most significant bit (MSB), which is at D4 of the Board Status Register (X'FC00').	
The twenty bit counters are subdivided into three groups: High Nibble (FC01), Middle Byte (FC02), and Low Byte (FC03). Each group is tested individually in the following manner.	

Table 5-13 (cont)

DISK OPTION ERRORS

ERROR CODE Binary / Hex	EXPLANATION
-- HIGH NIBBLE TEST --	
Test high nibble first because all bits must ripple through the high nibble while testing the middle and low bytes.	
STEP SET-UP	
1. Load High Nibble with 0.	
2. Does D4 = 0 ? See NOTE.	
TEST	
3. Load Middle Byte and Low Byte with X'FF.'	
4. Step DMA.	
5. Does D4 = 0 ?	
TEST	
6. Repeat steps 3 through 5 eight times.	
7. On eighth time, does D4 = 1 ?	
8. Repeat another eight times. (D4 should = 1 for these eight.)	
9. On sixteenth time, does D4 = 0 ?	
NOTE 9: If D=1 an error message is reported. All "D=N?" steps will cause an error unless the number is as expected. Error messages are in the accompanying tables.	
DMA Address Check (continued)	
-- MIDDLE BYTE TEST --	
STEP SET-UP	
10. Load High Nibble with 7.	
11. Does D4 = 0 ?	
12. Load Middle Byte X'FF.'	
TEST	
13. Load Low Byte with X'FF.'	
14. Step DMA.	
15. Does D4 = 0 ?	
16. Reload Low Byte with X'FF' (leave Middle Byte since we are testing it).	
17. Repeat steps 13 through 15; on 256th does D4 = 1? (Does High Nibble equal eight?).	

Circuits used: FDC, Board Status, Control Strobes, Data MUX, and Address Decode.

Table 5-13 (cont)
DISK OPTION ERRORS

ERROR CODE Binary / Hex	EXPLANATION
----------------------------	-------------

SET-UP

- 18. Reload High Nibble with F.
- 19. Does D4 = 1 ?

TEST

- 20. Reload Low Byte with X'FF,' and Step DMA.
- 21. Repeat step 19 twohundred fiftysix times.
- 22. On 256th time does D4 = 0 ? (High Nibble = 0)

-- LOW BYTE TEST --

Same procedure as Middle Byte test except the Low Byte and Middle Byte are reversed.

Error Messages for DMA Address Counters

Submessages (printed on screen):

"Disk - DMA Address Counters
- ADR19-1 Error

"Early 0-1 @ FC01"	Error detected at steps 2 or 5 (Counter reached 8 too soon)
"No 0-1 @ FC01"	Error detected at step 7.
"Early 1-0 @ FC01"	Error detected at step 8.
"No 1-0 @ FC01"	Error detected at step 9.
"Early 0-1 @ FC02"	Error detected at steps 11 or 15.
"No 0-1 @ FC02"	Error detected at step 17.
"Early 1-0 @ FC02"	Error detected at step 19.
"No 1-0 @ FC02"	Error detected at step 22.
"Early 0-1 @ FC03"	Same explanation as for FC02 messages, above, except substitute FC03 for FC02 in explanation of Middle Byte tests.
"No 0-1 @ FC03"	
"Early 1-0 @ FC03"	
"No 1-0 @ FC03"	

These tests check the clocking and carries of one counter to the next.

Circuits used: Same circuit blocks as used in DMA Operation Check, except Data MUX not used.

Tablet Self-Test Error Codes. The light codes for the tablet are indicative of failure of the tablet to complete a Self-Test sequence; the operation of the Tablet Controller board should be investigated.

During the tablet test, the proper error message is printed on the terminal screen if a test fails to pass. These submessages are accompanied by one of the following light codes (listed in Table 5-14).

A soft error will allow the tablet to be used. It alerts the operator that a problem exists.

A fatal error removes the tablet from the interrupt routine of the terminal. The tablet can not be used until the problem is corrected and the error cleared.

Table 5-14

TABLET ERROR MESSAGES

ERROR CODE Binary / Hex	EXPLANATION
0100 1111 4F	Board Communications check error.
	Submessage: (printed on screen)
	"Tablet -Board I/O Timeout"
	May appear during either the Power-Up sequence or Self-Test. It indicates that the terminal firmware is unable to communicate with the Tablet Controller board, and that a processor timeout occurred when communication was attempted. This is a FATAL error.
0100 1110 4E	Data Register bit check error.
	Submessage: (printed on screen)"
	"Tablet -Data Register Bit Error"
	Each individual bit of the data register is tested for set and reset. Message indicates at least one bit is not acting properly. This is a SOFT error.

Table 5-14 (cont)
 TABLET ERROR MESSAGES

ERROR CODE			EXPLANATION
Binary	/	Hex	
0100	1101	4D	Data Register count check error
Submessage: (printed on screen) - Only one of the following submessages will accompany the light code:			
"Tablet -Data Register Counting Error (Low)"			
Indicates that the data register was incapable of counting from 0 to 31 by one. This is a SOFT error.			
"Tablet -Data Register Counting Error (High)"			
Indicates that the data register was incapable of counting from 0 to 65539 by 29. This is a SOFT error.			
0100	1100	4C	Digitization check error.
Submessage: (printed on screen) - Only one of the following submessages will accompany the light code:			
"Tablet -Digitization Timeout Error"			
A start digitization command was given to the tablet and one of the FIRE pulses was not returned within 0.5 seconds. This is a SOFT error.			
"Tablet -Digitization Firing Sequence Error"			
The status bits, indicating which data firing (X1, X2, Y1, Y2) is present, were out of sequence. This is a SOFT error.			

Table 5-14 (cont)
 TABLET ERROR MESSAGES

ERROR CODE Binary / Hex	EXPLANATION
"Tablet -Erroneous Interrupting Indication"	The tablet status indicates that it is trying to interrupt the processor when it should not. This is a SOFT error.
"Tablet -failed To Interrupt"	Indicates the tablet status is not trying to interrupt the processor when it should. This is a SOFT error.
"Tablet -Data Register Counting Error (Digitization)"	The data register failed to count at all during a start digitization. This is a SOFT error.

ADJUSTMENT SELF-TEST

Adjustment Self-Test is the third diagnostic program that can be used to check the terminal. Adjustment Self-Test is started in the same manner as the main Self-Test (the second part of the functional check). A procedure and some guidelines for Adjustment Self-Test are outlined as follows:

1. Start Adjustment Self-Test running by pressing and holding the SELF TEST and MASTER RESET buttons.
2. Release the MASTER RESET button.
3. After the keyboard lights begin to "cycle," release the SELF TEST button.
4. The keyboard LEDs will all turn on, and then off, and then cycle twice. This is the same as during main Self-Test.
5. After the keyboard lights finish "cycling," the keyboard bell will ring once. Then press the CTRL and C keys at the same time.
6. Once CONTROL C has been pressed, the terminal will pause for a few seconds and then display a general menu on the screen. The terminal is now in the Adjustment part of Self-Test.
7. The general menu tells which key to press to check any specified part of the terminal. These keys are always one of the eight "function keys" across the upper-left part of the keyboard.
8. Once one of these keys (designated by the menu) is pressed, a second menu (submenu) will be displayed.

Table 5-15

ADJUSTMENT CONTROL KEYS

KEY	ACTION
CONTROL C	-- Displays (returns to) the general Self-Test menu.
CONTROL D	-- Displays the current menu.
CONTROL E	-- Exits from the current routine.
SPACE BAR	-- Repeats the current pattern/test.
Shifted Keys	-- A second function for specified key. The letters "Sh" in front of the key designation on the menu, means press the SHIFT key along with the designated key.

The General Menu

The General Menu is the first message that appears on the screen after Adjustment Self-Test is entered. The general menu is common for all 4110 series terminals. An example of the general menu is shown below.

```

411X Menu
--
f1 4114 Display
f2 Processor Board
f3 Disk
f4 3PPI
--
Selection
    
```

The Disk, 3PPI, and Tablet functions only appear if that options is installed. The options may change key designations depending on which options are installed. For instance, if no disk options were installed, but the tablet and 3PPI options were, the 3PPI option would be selected by F3, and the tablet options would be selected by F4. Adjustment Self-Test for the tablet is used only in adjusting the tablet when Options 13 or 14 are installed. It is not used in this function check procedure.

During Adjustment Self-Test, pressing CONTROL C will always cause this menu to be printed on the screen.

Display Menu

After the general menu is obtained, select the display menu by pressing F1. This key is in the upper-left corner of the keyboard. After the 4114 Display Menu is selected, the following will appear on the screen:

```

4114 Display Menu
--
f1 Hard Copy
f2 Gain
f3 X Comp
f4 Y Comp
f5 Focus
f6 Defocus
f7 Beam LL-Inv
f8 Beam UR-Inv
Sh f1 Charge Pump
--
Selection
*
    
```

These patterns can be used during the functional check to ensure that all display parameters are functioning properly.

f1 Hard Copy-S (Storage)

1. Press F1 to display the Hard Copy pattern.
2. Press space bar.
3. Observe the pattern erase and reappear.

f2 Gain-R (Refresh)

1. Press F2 to display Gain pattern in refresh mode.
2. Observe the crossed lines Gain pattern.
3. Press space bar.
4. Observe the Gain pattern change to storage mode.

f3 X Comp-R

1. Press F3 to display the X Comp pattern.
2. Observe only one tail (line) should be visible on each side of the screen.

f4 Y Comp-R

1. Press F4 to display the Y Comp pattern.
2. Observe only one tail (line) should be visible on the top and bottom of the screen.

f5 Focus-S

1. Press F5 to display the Focus pattern.
2. Observe the Focus pattern for uniform focus on the screen.

f6 Defocus-S

1. Press F6 to display the Defocus pattern.
2. Observe the Defocus pattern for a broad middle line in the individual patterns.

f7 Beam LL-Inv-R

1. Press F7 to display the Beam LL-Inv pattern (invisible).
2. Observe that no pattern is visible on the lower left-hand corner of the screen.

f8 Beam UR-Inv-R

1. Press F8 to display the Beam UR-Inv pattern (invisible).
2. Observe that no pattern is visible on the upper right-hand corner of the screen.

Sh f1 Charge Pump-R

1. Press SHIFT and F1 keys together to display the Charge Pump pattern.
2. Observe the Charge Pump pattern for straight and unbroken lines.

SELF-TEST DIAGNOSTIC PROGRAM

Processor Board Menu

Once the General Menu has been displayed on the screen, select the Processor Board menu by pressing F2. After F2 is pressed, the Processor Board menu is displayed. The Processor Board menu looks like this:

```
Processor Board Menu
--
f1 CMOS-Reset
f2 Keyboard
f3 Host Port
--
Selection
*
```

Working from the Processor Board menu, perform the following tests.

CMOS-Reset, Function Key F1. CMOS-Reset is used to restore the factory default settings of all the CMOS parameters. From the Processor Board menu, press F1 function key. This action prints the following message on the display:

```
*f1
CMOS-Reset
Selection
*
```

This message means that the terminal's operating parameters have been restored to their factory default settings.

Keyboard, Function Key F2. Pressing the F2 key causes every key on the keyboard to display two 2-digit hexadecimal numbers. These numbers represent the 8-bit codes that the Processor Board generates for each downstroke and upstroke of a key. Each key has its own distinct hexadecimal code, and each downstroke code is different than the corresponding upstroke code. The first number of the up-stroke code is always eight more than the first number of the downstroke code. The second character in the code is the same for both the down-stroke and the up-stroke of the key. This routine will verify that each key is operating properly. Figure 5-7 shows the Keyboard keycodes.

Now return to the Processor Board menu by pressing CTRL D.

Host Port Check, Function Key F3. The Host Port routine checks the validity of the output port of the terminal. Enter the Host Port routine by pressing F3. Once this is done, the screen displays the following message:

```
Host Port
Attach Loopback
Press SpcBar
```

Connect the special loopback connector from the output port back to the input port. These connections are located on the rear panel of the terminal. See Accessories List for the Loopback Connector part number.

After the cable is connected, press the space bar. This starts the routine that sends signals representing characters 7F through 00 (at baud rates 9600 through 300). When this string of signals is sent and received properly, the screen indicates it by printing "Complete." This message means the terminal is ready to go onto the next test.

If there is an error during the Host Port routine, the following submessage will appear on the screen:

```
"Host Port-Baud/Character
Baud: XXXX Expect: YY-AA Receive: ZZ-BB"
```

This means:

```
XXXX is the baud rate in hexadecimal.
YY   is the signal sent (for example: 7F).
AA   is the expected bits in error, this should
      always read 00.
ZZ   is the signal received.
BB   is the bits in error.
```

After this Host Port check is complete, return to the general menu by pressing CONTROL C. If there are no options installed, this completes the functional check of the terminal. If there are options installed, select each option listed in the general menu and perform the following checks for that option.

NOTE

Only the disk and 3PPI options may be functionally checked using Adjustment Self-Test. The tablet menu is used for alignment purposes of the Graphic Tablet only (which is external to the terminal). The electronics for the tablet that resides in the terminal (Tablet Controller Board) were checked during main Self-Test. An alignment procedure for the graphic tablet using Adjustment Self-Test is contained in the 4110 Series F13/14 Graphic Tablet Instruction Manual.

Disk Option Menu

The Disk Menu may be obtained from the general menu by pressing F3. The Disk Menu is an optional menu and will only appear if Option 42 is installed. Just as Self-Test checked out the electronics of the Disk Controller board, this routine checks the drive unit. This menu is useful for drive unit head alignment. For this purpose a special alignment diskette (not used in this functional check) is required.

NOTE

The following is only a functional check and not an alignment procedure. This check only ensures that no error messages are received and that the drive does not hang up. An alignment procedure for the disk drives is found in the "4110 Series F42/43 Disk Options Service Manual," and the "Flexible Disk Drive Instruction Manual."

This is an example of the Disk Menu (items are self explanatory):

```

Disk Menu
--
f1 No Operation
f2 Step up One Track
f3 Step Down One Track
f4 Seek Track 0
f5 Seek Track 1
f6 Seek Track 38
f7 Seek Track 75
f8 Seek Track 76
Sh f1 Load Head
Sh f2 Unload Head
Sh f3 Arms Write Mode
Sh f4 Writes Track 76 With a 2F Pattern
Sh f5 Select Your Own Track
Sh f6 Change Device (Drive Unit) Address
Sh f7 Auto Load And Unload The Head On Track 0
--
Selection
    
```

If the disk option is installed, insert a disk in the drive unit before starting this test. Then make sure the WRITE PROTECT switch is set to the off position (the light is not lit).



It is best to perform this part of the functional check using a disk free of data. Performing this test may cause some data to be written on the disk. With the write protect switch off, it is possible to write over existing data. Therefore, it is best to use an outdated disk or one that contains unwanted data.

Press each of the disk menu keys in succession. No error messages should be received on any of the tests and the head should move to the selected area on the disk. After running through the head movements (in the menu), press CTRL C to return to the general menu.

NOTE

This is merely a check of the disk drive unit to ensure that no error messages are received and that the drive does not hang up. For a full alignment procedure of the drive unit, see the "4110 Series F42/43 Disk Options Service Manual."

**TABLET ADJUSTMENT MENU/
PROCEDURE**

When the Tablet is selected from the general menu (part of Adjustment Self-Test), the following tablet menu will appear on the screen:

```
Tablet Menu
--
f1 Tablet Timing Adjustment
--
Selection
*
```

At this time, the interconnect cable must be connected between the Graphic Tablet and the 4114 graphic tablet port. Once this is done, the F1 key may be pressed.

The following submessages can be used to aid in adjusting the surface accuracy of the tablet. For more information on tablet adjustments, consult the Option F13/14 Graphics Tablet Instruction Manual. These submessages appear while running the Adjustment part of Self-Test only.

Submessages: (printed on screen)

Warning: -Tablet Firing Sequence Error -

The status bits which indicate which data firing (X1, X2, Y1, Y2) is being received are out of sequence. This is a warning only; the routine will proceed normally. This message can indicate a problem on any of the circuit boards associated with the tablet.

X = NNN,NNN, Y = NNN,NNN, Button = N (using a Cursor Pen)

This is the standard message. It is displayed whenever the Z-axis switch is depressed while in presence. It displays X and Y in inches from the margin, the button number depressed (0 for stylus; Z, 1, 2, 3 for a cursor.) It also indicates whether a pen (stylus) or cursor is in use.

X Timing Straps = NNNNNNN, Y Timing Straps = NNNNNNN

This message is printed whenever a Z-axis switch is depressed with the stylus out of presence. It is a binary readout of the timing strap settings. A comparison of this readout with the actual strap settings will verify the proper operation of the timing straps.

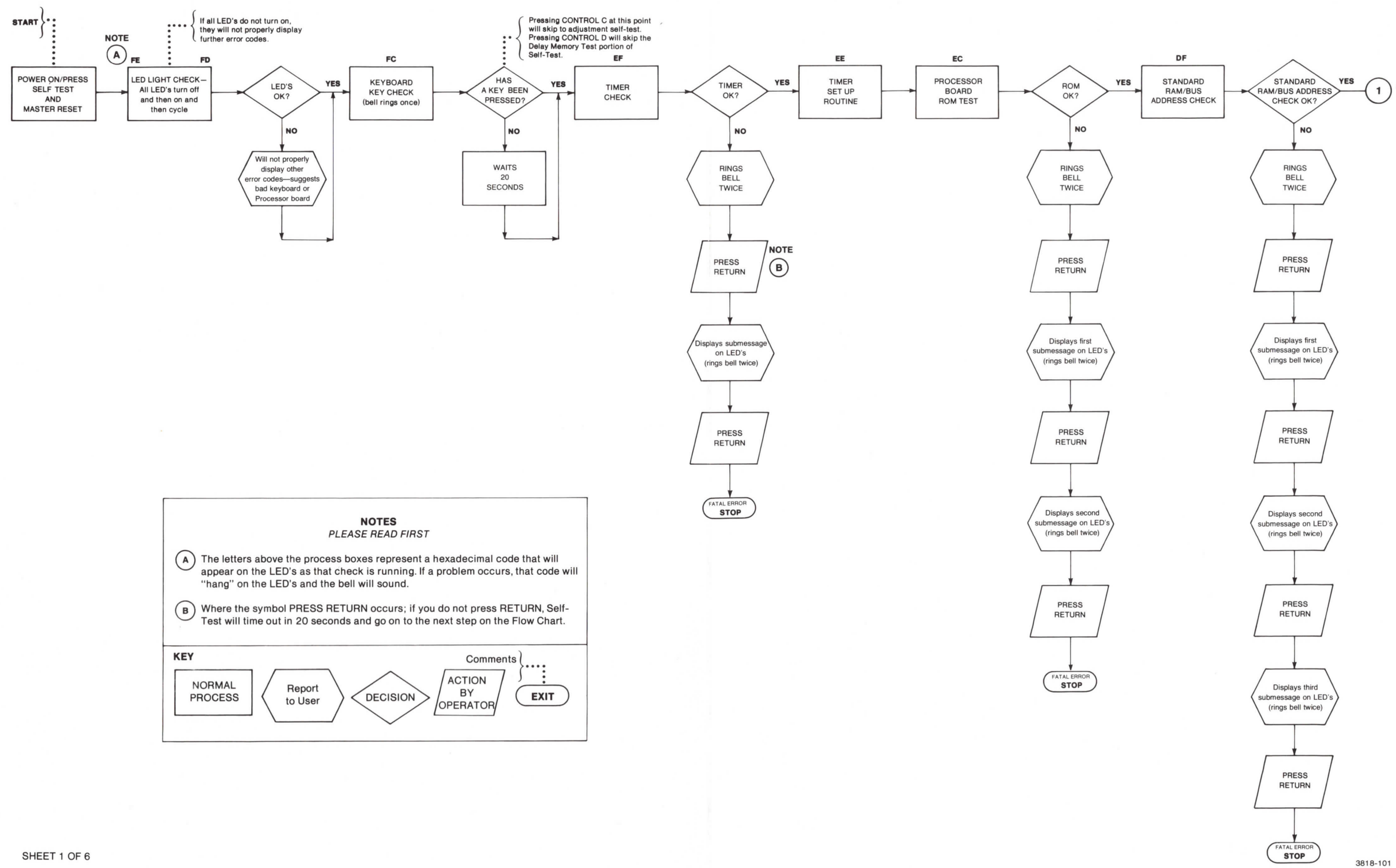

Figure 5-7A. 4114 Self-Test Control Flow.

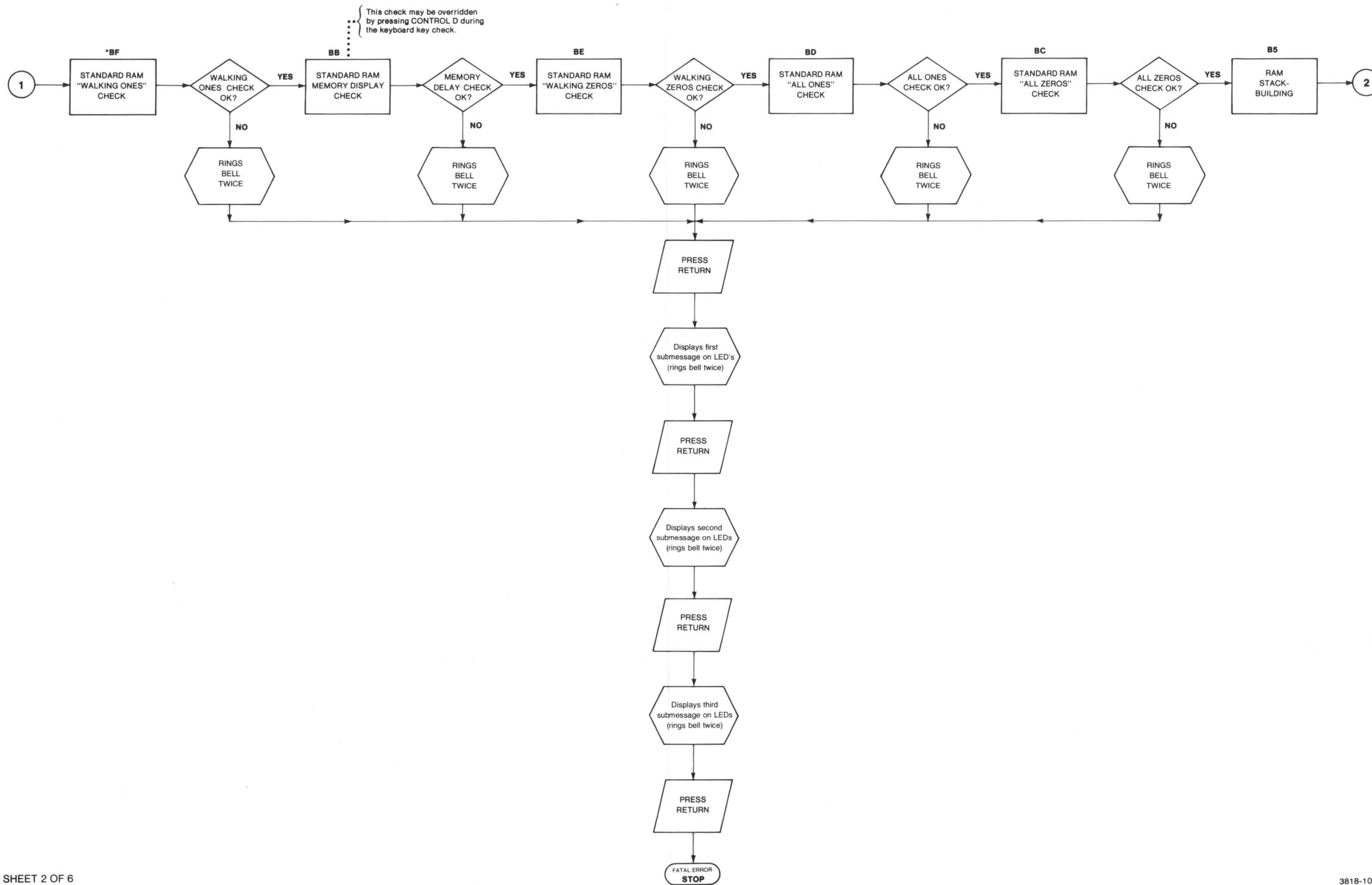
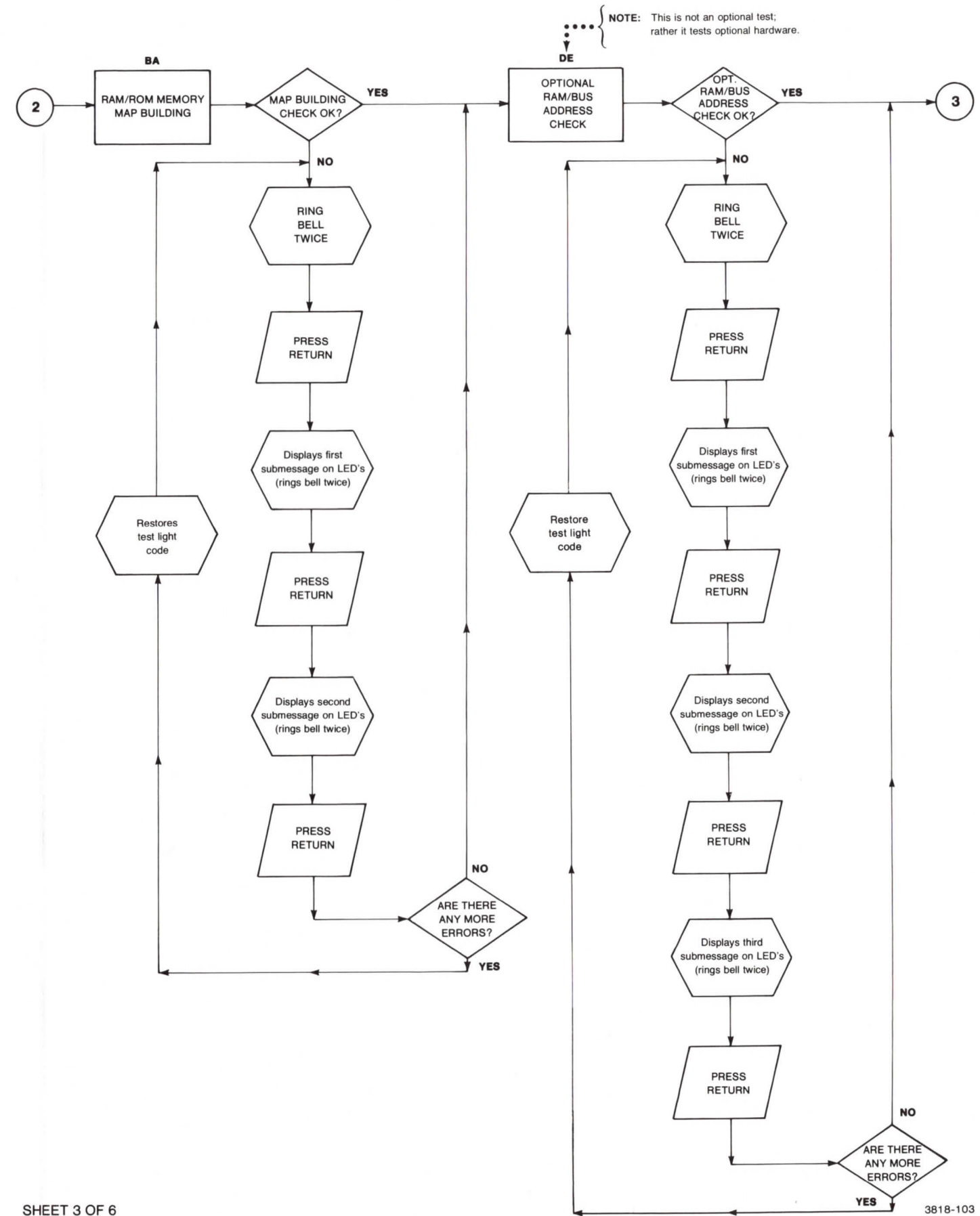

Figure 5-7B. 4114 Self-Test Control Flow (cont).



SHEET 3 OF 6

Figure 5-7C. 4114 Self-Test Control Flow (cont).

3818-103

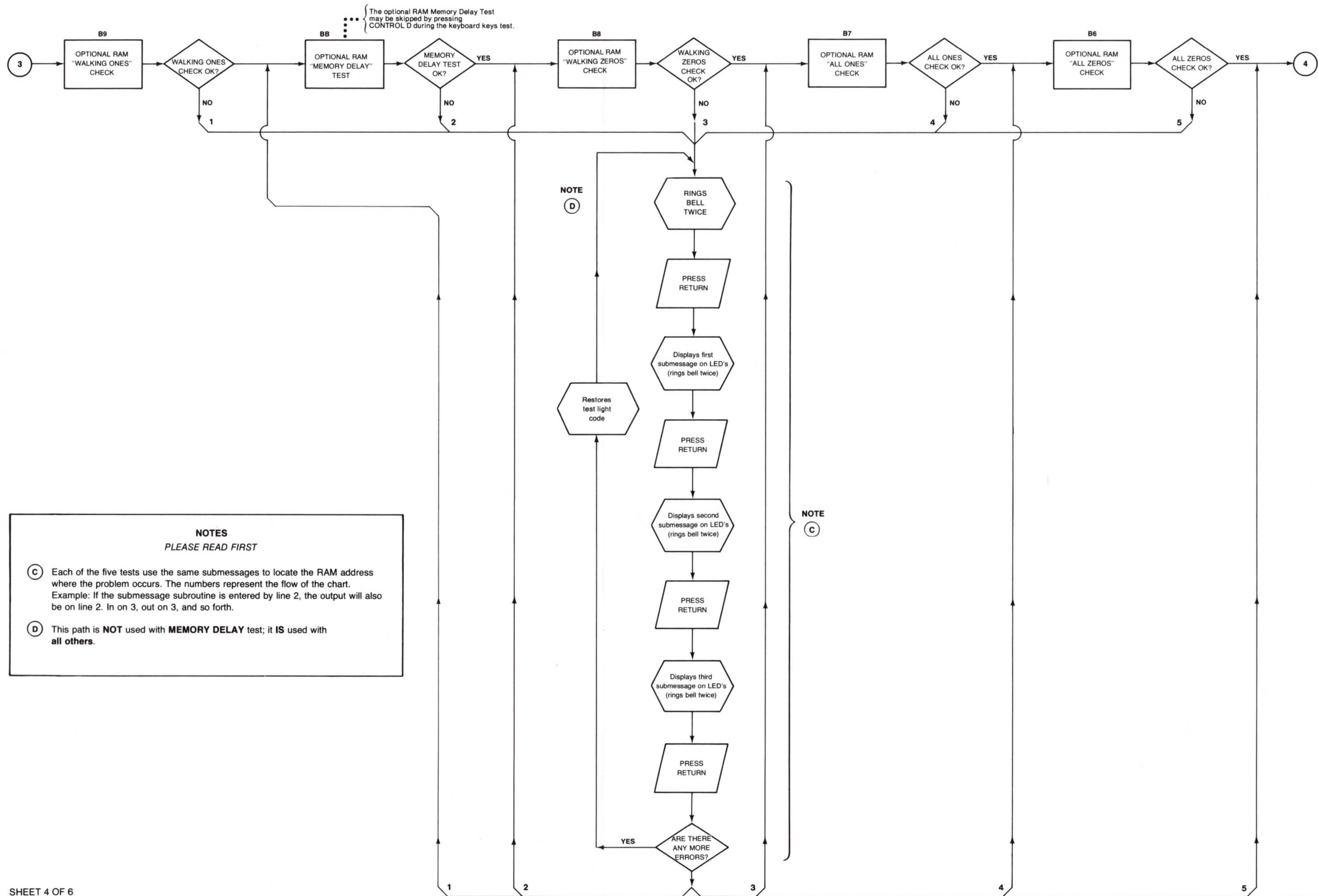
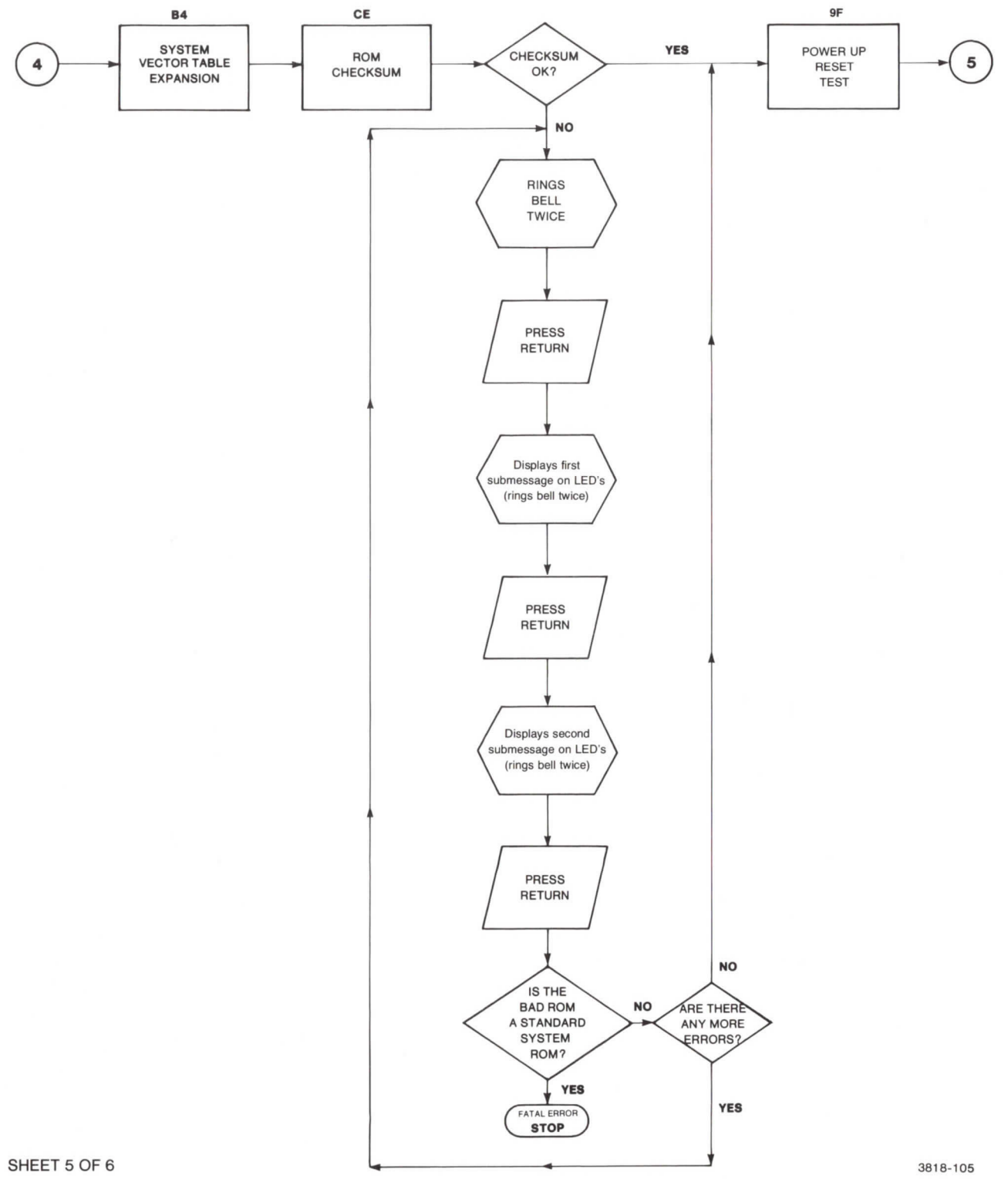

Figure 5-7D. 4114 Self-Test Control Flow (cont).



SHEET 5 OF 6

3818-105

Figure 5-7E. 4114 Self-Test Control Flow (cont).

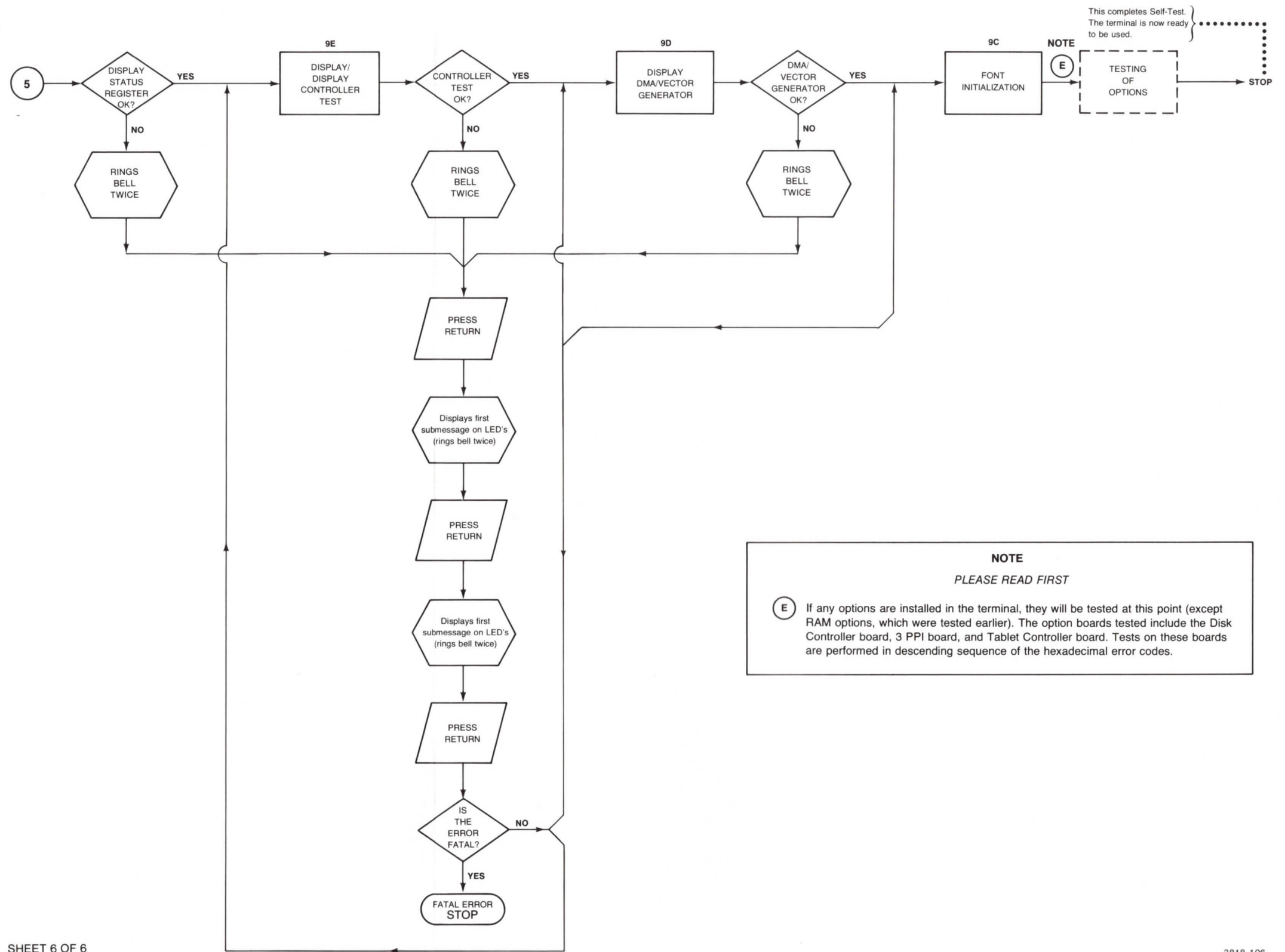

SHEET 6 OF 6

3818-106

Figure 5-7F. 4114 Self-Test Control Flow (cont).

4114 SELF-TEST
 FIGURE 5-7F

Section 6

REPLACEABLE ELECTRICAL PARTS

PARTS ORDERING INFORMATION

Replacement parts are available from or through your local Tektronix, Inc. Field Office or representative.

Changes to Tektronix instruments are sometimes made to accommodate improved components as they become available, and to give you the benefit of the latest circuit improvements developed in our engineering department. It is therefore important, when ordering parts, to include the following information in your order: Part number, instrument type or number, serial number, and modification number if applicable.

If a part you have ordered has been replaced with a new or improved part, your local Tektronix, Inc. Field Office or representative will contact you concerning any change in part number.

Change information, if any, is located at the rear of this manual.

LIST OF ASSEMBLIES

A list of assemblies can be found at the beginning of the Electrical Parts List. The assemblies are listed in numerical order. When the complete component number of a part is known, this list will identify the assembly in which the part is located.

CROSS INDEX-MFR. CODE NUMBER TO MANUFACTURER

The Mfr. Code Number to Manufacturer index for the Electrical Parts List is located immediately after this page. The Cross Index provides codes, names and addresses of manufacturers of components listed in the Electrical Parts List.

ABBREVIATIONS

Abbreviations conform to American National Standard Y1.1.

COMPONENT NUMBER (column one of the Electrical Parts List)

A numbering method has been used to identify assemblies, subassemblies and parts. Examples of this numbering method and typical expansions are illustrated by the following:

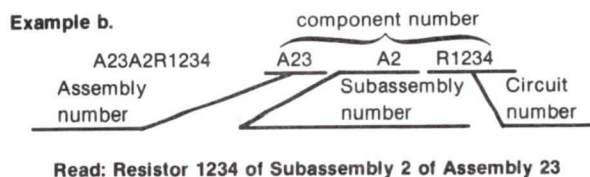
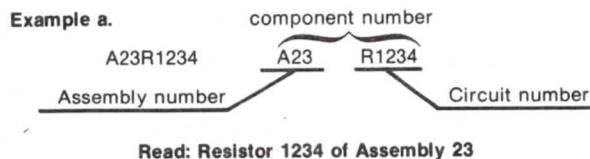

Only the circuit number will appear on the diagrams and circuit board illustrations. Each diagram and circuit board illustration is clearly marked with the assembly number. Assembly numbers are also marked on the mechanical exploded views located in the Mechanical Parts List. The component number is obtained by adding the assembly number prefix to the circuit number.

The Electrical Parts List is divided and arranged by assemblies in numerical sequence (e.g., assembly A1 with its subassemblies and parts, precedes assembly A2 with its subassemblies and parts).

Chassis-mounted parts have no assembly number prefix and are located at the end of the Electrical Parts List.

TEKTRONIX PART NO. (column two of the Electrical Parts List)

Indicates part number to be used when ordering replacement part from Tektronix.

SERIAL/MODEL NO. (columns three and four of the Electrical Parts List)

Column three (3) indicates the serial number at which the part was first used. Column four (4) indicates the serial number at which the part was removed. No serial number entered indicates part is good for all serial numbers.

NAME & DESCRIPTION (column five of the Electrical Parts List)

In the Parts List, an Item Name is separated from the description by a colon (:). Because of space limitations, an Item Name may sometimes appear as incomplete. For further Item Name identification, the U.S. Federal Cataloging Handbook H6-1 can be utilized where possible.

MFR. CODE (column six of the Electrical Parts List)

Indicates the code number of the actual manufacturer of the part. (Code to name and address cross reference can be found immediately after this page.)

MFR. PART NUMBER (column seven of the Electrical Parts List)

Indicates actual manufacturers part number.

REPLACEABLE ELECTRICAL PARTS

CROSS INDEX—MFR. CODE NUMBER TO MANUFACTURER

Mfr. Code	Manufacturer	Address	City, State, Zip
000CA	MOLEX	2222 WELLINGTON COURT	LYLE, ILLINOIS 60532
000FG	RIFA WORLD PRODUCTS INC.	7625 BUSH LAKE RD P.O. BOX 35263	MINNEAPOLIS, MN 55435
0000L	MATSUSHITA ELECTRIC	200 PARK AVENUE, 54TH FLOOR	NEW YORK, NY 10017
00779	AMP, INC.	P O BOX 3608	HARRISBURG, PA 17105
00853	SANGAMO ELECTRIC CO., S. CAROLINA DIV.	P O BOX 128	PICKENS, SC 29671
01002	GENERAL ELECTRIC COMPANY, INDUSTRIAL AND POWER CAPACITOR PRODUCTS DEPARTMENT	JOHN STREET	HUDSON FALLS, NY 12839
01121	ALLEN-BRADLEY COMPANY	1201 2ND STREET SOUTH	MILWAUKEE, WI 53204
01281	TRW ELECTRONIC COMPONENTS, SEMICONDUCTOR OPERATIONS	14520 AVIATION BLVD.	LAWNDALE, CA 90260
01295	TEXAS INSTRUMENTS, INC., SEMICONDUCTOR GROUP	P O BOX 5012, 13500 N CENTRAL EXPRESSWAY	DALLAS, TX 75222
01807	PETERSEN RADIO COMPANY, INC.	2800 WEST BROADWAY	COUNCIL BLUFFS, IN 51501
02735	RCA CORPORATION, SOLID STATE DIVISION	ROUTE 202	SOMERVILLE, NY 08876
02777	HOPKINS ENGINEERING COMPANY	12900 FOOTHILL BLVD.	SAN FERNANDO, CA 91342
03508	GENERAL ELECTRIC COMPANY, SEMI-CONDUCTOR PRODUCTS DEPARTMENT	ELECTRONICS PARK	SYRACUSE, NY 13201
04222	AVX CERAMICS, DIVISION OF AVX CORP.	P O BOX 867, 19TH AVE. SOUTH	MYRTLE BEACH, SC 29577
04713	MOTOROLA, INC., SEMICONDUCTOR PROD. DIV.	5005 E MCDOWELL RD, PO BOX 20923	PHOENIX, AZ 85036
05574	VIKING INDUSTRIES, INC.	21001 NORDHOFF STREET	CHATSWORTH, CA 91311
07263	FAIRCHILD SEMICONDUCTOR, A DIV. OF FAIRCHILD CAMERA AND INSTRUMENT CORP.	464 ELLIS STREET	MOUNTAIN VIEW, CA 94042
08057	MAGNETICS DIV OF SPANG INDST. INC.	230 ADRIAN RD.	MILLBRAE, CA 94030
09023	CORNELL-DUBILIER ELECTRONIC DIVISION	2652 DALRYMPLE ST.	SANFORD, NC 27330
09353	FEDERAL PACIFIC ELECTRIC CO.	103 MORSE STREET	WATERTOWN, MA 02172
11236	C AND K COMPONENTS, INC.	406 PARR RD.	BERNE, IN 46711
12697	CTS OF BERNE, INC.	LOWER WASHINGTON STREET	DOVER, NH 03820
12969	CLAROSTAT MFG. CO., INC.	580 PLEASANT STREET	WATERTOWN, MA 02172
13050	UNITRODE CORPORATION	HWY 51 N	WESSON, MS 39191
13919	POTTER CO.	PO BOX 11400, 6730 S TUCSON BLVD.	TUCSON, AZ 85706
14193	BURR-BROWN RESEARCH CORPORATION	1601 OLYMPIC BLVD.	SANTA MONICA, CA 90404
14433	CAL-R, INC.	3301 ELECTRONICS WAY	WEST PALM BEACH, FL 33402
14552	ITT SEMICONDUCTORS	P O BOX 3049	SANTA ANA, CA 92704
14752	MICRO SEMICONDUCTOR CORP.	2830 E FAIRVIEW ST.	SAN GABRIEL, CA 91776
14952	ELECTRO CUBE INC.	1710 S. DEL MAR AVE.	SANTA ROSA, CA 95402
15238	OPTICAL ENGINEERING INC.	2495 BLUE BELL DR. P.O. BOX 696	SANTA ROSA, CA 95402
15454	ITT SEMICONDUCTORS, A DIVISION OF INTERNATIONAL TELEPHONE AND TELEGRAPH CORP.	P.O. BOX 168, 500 BROADWAY	LAWRENCE, MA 01841
18324	RODAN INDUSTRIES, INC.	2905 BLUE STAR ST.	ANAHEIM, CA 92806
19396	SIGNETICS CORP.	811 E. ARQUES	SUNNYVALE, CA 94086
22526	ILLINOIS TOOL WORKS, INC. PAKTRON DIV.	900 FOLLIN LANE, SE	VIENNA, VA 22180
23223	BERG ELECTRONICS, INC.	YOUK EXPRESSWAY	NEW CUMBERLAND, PA 17070
24546	CTS MICROELECTRONICS, INC.	1201 CUMBERLAND AVENUE P O BOX 1278	WEST LAFAYETTE, IN 47902
25403	CORNING GLASS WORKS, ELECTRONIC COMPONENTS DIVISION	550 HIGH STREET	BRADFORD, PA 16701
27014	AMPEREX ELECTRONIC CORP., SEMICONDUCTOR AND MICROCIRCUITS DIV.	PROVIDENCE PIKE	SLATERSVILLE, RI 02876
27264	NATIONAL SEMICONDUCTOR CORP.	2900 SEMICONDUCTOR DR.	SANTA CLARA, CA 95051
31918	MOLEX PRODUCTS CO.	5224 KATRINE AVE.	DOWNERS GROVE, IL 60515
32159	IEE/SCHADOW INC.	8081 WALLACE ROAD	EDEN PRAIRIE, MN 55343
32997	WEST-CAP ARIZONA	2201 E. ELVIRA ROAD	TUCSON, AZ 85706
33096	BOURNS, INC., TRIMPOT PRODUCTS DIV.	1200 COLUMBIA AVE.	RIVERSIDE, CA 92507
34333	COLORADO CRYSTAL CORPORATION	2303 W 8TH STREET	LOVELAND, CO 80537
34335	SILICON GENERAL, INC.	7382 BOLSA AVE.	WESTMINSTER, CA 92683
34371	ADVANCED MICRO DEVICES	901 THOMPSON PL.	SUNNYVALE, CA 94086
34649	HARRIS SEMICONDUCTOR, DIV. OF HARRIS CORPORATION	P. O. BOX 883	MELBOURNE, FL 32901
50434	INTEL CORP.	3065 BOWERS AVE.	SANTA CLARA, CA 95051
50558	HEWLETT-PACKARD COMPANY	640 PAGE MILL ROAD	PALO ALTO, CA 94304
51181	ELECTRONIC CONCEPTS, INC.	526 INDUSTRIAL WAY WEST	EATONTOWN, NJ 07724
	KEYTRONICS INC.	707 NORTH ST.	ENDICOTT, NY 13760

CROSS INDEX—MFR. CODE NUMBER TO MANUFACTURER

Mfr. Code	Manufacturer	Address	City, State, Zip
51984	NEC AMERICA INC. RADIO AND TRANSMISSION DIV.	2990 TELESTAR CT. SUITE 212	FALLS CHURCH, VA 22042
52306	HIGH VOLTAGE DEVICES, INC.	7485 AVENUE 304	VISALIA, CA 93277
52833	KEYTRONIC CORP., OCR DIV.	SPOKANE INDUSTRIAL PK., P. O. BOX 14687	SPOKANE, WA 99214
53944	ELT INC., GLOW LITE DIVISION	BOX 698	PAULS VALLEY, OK 73075
54473	MATSUSHITA ELECTRIC, CORP. OF AMERICA	1 PANASONIC WAY	SECAUCUS, NJ 07094
55210	GETTIG ENG. AND MFG. COMPANY	PO BOX 85, OFF ROUTE 45	SPRING MILLS, PA 16875
55680	NICHICON/AMERICA/CORP.	6435 N PROESEL AVENUE	CHICAGO, IL 60645
55857	GOULD INC. PORTABLE BATTERY DIV.	2777 EAGANDALE BLVD	EAGAN, MN 55121
56289	SPRAGUE ELECTRIC CO.	87 MARSHALL ST.	NORTH ADAMS, MA 01247
59660	TUSONIX INC.	2155 N FORBES BLVD	TUCSON, AZ 85705
63743	WARD LEONARD ELECTRIC CO., INC.	31 SOUTH ST.	MOUNT VERNON, NY 10550
71400	BUSSMAN MFG., DIVISION OF MCGRAW-EDISON CO.	2536 W. UNIVERSITY ST.	ST. LOUIS, MO 63107
72982	ERIE TECHNOLOGICAL PRODUCTS, INC.	644 W. 12TH ST.	ERIE, PA 16512
73138	BECKMAN INSTRUMENTS, INC., HELIPOT DIV.	2500 HARBOR BLVD.	FULLERTON, CA 92634
74276	SIGNALITE DIV., GENERAL INSTRUMENT CORP.	1933 HECK AVE.	NEPTUNE, NJ 07753
75042	TRW ELECTRONIC COMPONENTS, IRC FIXED RESISTORS, PHILADELPHIA DIVISION	401 N. BROAD ST.	PHILADELPHIA, PA 19108
75378	CTS KNIGHTS, INC.	400 REIMANN AVE.	SANDWICH, IL 60548
75915	LITTELFUSE, INC.	800 E. NORTHWEST HWY	DES PLAINES, IL 60016
80009	TEKTRONIX, INC.	P O BOX 500	BEAVERTON, OR 97077
82389	SWITCHCRAFT, INC.	5555 N. ELSTON AVE.	CHICAGO, IL 60630
82877	ROTRON, INC.	7-9 HASBROUCK LANE	WOODSTOCK, NY 12498
83003	VARO, INC.	P O BOX 411, 2203 WALNUT STREET	GARLAND, TX 75040
90201	MALLORY CAPACITOR CO., DIV. OF P. R. MALLORY AND CO., INC.	3029 E. WASHINGTON STREET	INDIANAPOLIS, IN 46206
90484	ITT, SURPRENANT DIV.	P. O. BOX 372	CLINTON, MA 01510
91418	RADIO MATERIALS COMPANY, DIV. OF P.R. MALLORY AND COMPANY, INC.	172 STERLING STREET	
91637	DALE ELECTRONICS, INC.	4242 W BRYN MAWR P. O. BOX 609	CHICAGO, IL 60646 COLUMBUS, NE 68601

REPLACEABLE ELECTRICAL PARTS

Component No.	Tektronix Part No.	Serial/Model No. Eff Dscnt	Name & Description	Mfr Code	Mfr Part Number
ASSEMBLIES					
A1	670-7062-00	B010100 B021749	CKT BOARD ASSY:MOTHER	80009	670-7062-00
A1	670-7062-01	B021750	CKT BOARD ASSY:MOTHER	80009	670-7062-01
A2	670-7063-00	B010100 B021749	CKT BOARD ASSY:MOTHER BOARD EXTENDER	80009	670-7063-00
	-----		(OPTION 40,41 ONLY)		
A2	670-7063-01	B021750	CKT BOARD ASSY:MOTHER BOARD EXTENDER	80009	670-7063-01
	-----		(OPTION 40,41 ONLY)		
A3	672-0949-00	B010100 B019999	CKT BOARD ASSY:PROCESSOR	80009	672-0949-00
A3	672-0949-01	B020000	CKT BOARD ASSY:PROCESSOR	80009	672-0949-01
A3A1	670-6496-XX		(NOT AVAILABLE,SEE A3)		
A4	119-1305-03		KEYBOARD,CMPTR:	52833	65-2035
	-----		(STANDARD,OPTION 4A ONLY)		
A4	119-1394-00		KEYBOARD ASSY:SWEDISH & DANISH	51181	66-02035-003
	-----		(OPTION 4C,4F ONLY)		
A4	119-1395-00		KEYBOARD ASSY:APL	51181	66-02035-002
	-----		(OPTION 4E ONLY)		
A5	672-0950-00	B010100 B010169	CKT BOARD ASSY:RAM ROM	80009	672-0950-00
A5	672-0950-01	B010170 B010219	CKT BOARD ASSY:RAM ROM	80009	672-0950-01
A5	672-0950-02	B010220	CKT BOARD ASSY:RAM ROM	80009	672-0950-02
A5A1	670-6940-XX		(NOT AVAILABLE,SEE A5)		
A6	670-6670-00		CKT BOARD ASSY:RAM ARRAY	80009	670-6670-00
A7	670-6669-00	B010100 B010169	CKT BOARD ASSY:RAM CONTROLLER	80009	670-6669-00
	-----		(OPTION 24 THRU 29 ONLY)		
A7	670-6669-01	B010170 B010429	CKT BOARD ASSY:RAM CONTROLLER	80009	670-6669-01
	-----		(OPTION 24 THRU 29 ONLY)		
A7	670-6669-02	B010430	CKT BOARD ASSY:RAM CONTROLLER	80009	670-6669-02
	-----		(OPTION 24 THRU 29 ONLY)		
A8	670-6494-02		CKT BOARD ASSY:DISPLAY CONTROLLER	80009	670-6494-02
A9	670-6495-00		CKT BOARD ASSY:VECTOR GENERATOR	80009	670-6495-00
A10	670-5291-XX		CKT BOARD ASSY:		
	-----		(NOT AVAILABLE,USE 067-1005-00)		
A11	670-5163-01		CKT BOARD ASSY:INTERCONNECT	80009	670-5163-01
A12	670-4798-03		CKT BOARD ASSY:L V POWER SUPPLY	80009	670-4798-03
A13	672-0795-03	B010100 B010169	CKT BOARD ASSY:STORAGE	80009	672-0795-03
A13	672-0795-04	B010170	CKT BOARD ASSY:STORAGE	80009	672-0795-04
A13A1	670-6127-XX		(NOT AVAILABLE,SEE A13)		
A14	670-3097-01		CKT BOARD ASSY:HARD COPY AMPL	80009	670-3097-01
A15	672-0901-01		CKT BOARD ASSY:DEFLECTION AMPLIFIER	80009	672-0901-01
A15A1	670-7007-XX		(NOT AVAILABLE,SEE A15)		
A16	672-0662-04		CKT BOARD ASSY:HIGH VOLTAGE & Z AXIS	80009	672-0662-04
A16A1	670-4804-XX		(NOT AVAILABLE,SEE A16)		
A17	620-0294-00	B010100 B021324	POWER SUPPLY:	80009	620-0294-00
A17	620-0294-01	B021325	POWER SUPPLY:	80009	620-0294-01
A17A1	670-6503-01	B010100 B010804	CKT BOARD ASSY:INVERTER	80009	670-6503-01
A17A1	670-6503-02	B010805 B021324	CKT BOARD ASSY:INVERTER	80009	670-6503-02
A17A1	670-6503-03	B021325	CKT BOARD ASSY:INVERTER	80009	670-6503-03
A17A2	670-6502-00	B010100 B021324	CKT BOARD ASSY:REGULATOR	80009	670-6502-00
A17A2	670-6502-01	B021325	CKT BOARD ASSY:REGULATOR	80009	670-6502-01

REPLACEABLE ELECTRICAL PARTS

Component No.	Tektronix Part No.	Serial/Model No. Eff Dscont	Name & Description	Mfr Code	Mfr Part Number
A1 MOTHER					
A1	670-7062-00	B010100 B021749	CKT BOARD ASSY:MOTHER	80009	670-7062-00
A1	670-7062-01	B021750	CKT BOARD ASSY:MOTHER	80009	670-7062-01
AlC100	290-0779-00		CAP.,FXD,ELCLT:10UF,+50-10%,50VDC	56289	502D237
AlCR201	152-0141-02		SEMICONV DEVICE:SILICON,30V,150MA	01295	1N4152R
AlCR202	152-0141-02		SEMICONV DEVICE:SILICON,30V,150MA	01295	1N4152R
AlCR301	152-0141-02		SEMICONV DEVICE:SILICON,30V,150MA	01295	1N4152R
AlCR501	152-0141-02		SEMICONV DEVICE:SILICON,30V,150MA	01295	1N4152R
AlF1	159-0194-00	XB021750	FUSE,WIRE LEAD:5A,125V,0.125SEC	75915	255-005
AlF2	159-0194-00	XB021750	FUSE,WIRE LEAD:5A,125V,0.125SEC	75915	255-005
AlF3	159-0194-00	XB021750	FUSE,WIRE LEAD:5A,125V,0.125SEC	75915	255-005
AlF4	159-0194-00	XB021750	FUSE,WIRE LEAD:5A,125V,0.125SEC	75915	255-005
AlF5	159-0194-00	XB021750	FUSE,WIRE LEAD:5A,125V,0.125SEC	75915	255-005
AlF17	159-0194-00	XB021750	FUSE,WIRE LEAD:5A,125V,0.125SEC	75915	255-005
AlJ1	131-2059-01		CONN,RCPT,ELEC:CKT BD,40/80 FEM W/O EARS	00779	3-530671-0
AlJ2	131-2059-01		CONN,RCPT,ELEC:CKT BD,40/80 FEM W/O EARS	00779	3-530671-0
AlJ3	131-2059-01		CONN,RCPT,ELEC:CKT BD,40/80 FEM W/O EARS	00779	3-530671-0
AlJ4	131-2059-01		CONN,RCPT,ELEC:CKT BD,40/80 FEM W/O EARS	00779	3-530671-0
AlJ16	131-2603-00		CONN,RCPT,ELEC:CIRCUIT BD,23/46 CONTACT	00779	4-86063-2
AlJ17	131-2621-00		CONN,RCPT,ELEC:HEADER,1 X 5,0.25 CTR	00779	640900-1
AlJ18	131-0608-00		TERMINAL,PIN:0.365 L X 0.025 PH BRZ GOLD (QUANTITY OF 15)	22526	47357
AlJ20	131-0608-00		TERMINAL,PIN:0.365 L X 0.025 PH BRZ GOLD (QUANTITY OF 4)	22526	47357
AlQ710	151-0679-00		TRANSISTOR:SILICON,NPN	04713	SJE362
AlQ720	151-0679-00		TRANSISTOR:SILICON,NPN	04713	SJE362
AlQ741	151-0657-00		TRANSISTOR:SILICON,PNP	04713	SJE1973
AlQ751	151-0656-00		TRANSISTOR:SILICON,NPN	04713	SJE1972
AlQ761	151-0528-00		TRANSISTOR:SILICON,50V,16A	04713	2N6400
AlQ771	151-0657-00		TRANSISTOR:SILICON,PNP	04713	SJE1973
AlQ785	151-0656-00		TRANSISTOR:SILICON,NPN	04713	SJE1972
AlQ795	151-0477-00		TRANSISTOR:SILICON,NPN	04713	SJE374
AlR7	315-0100-00		RES.,FXD,CMPN:10 OHM,5%,0.25W	01121	CB1005
AlR101	315-0102-00		RES.,FXD,CMPN:1K OHM,5%,0.25W	01121	CB1025
AlR102	307-0596-00		RES NTWK,FXD FI:7,2.2K OHM,2%,1.0W	91637	MSP08A01222G
AlR201	307-0596-00		RES NTWK,FXD FI:7,2.2K OHM,2%,1.0W	91637	MSP08A01222G
AlR202	307-0596-00		RES NTWK,FXD FI:7,2.2K OHM,2%,1.0W	91637	MSP08A01222G
AlR203	315-0102-00		RES.,FXD,CMPN:1K OHM,5%,0.25W	01121	CB1025
AlR204	315-0621-00		RES.,FXD,CMPN:620 OHM,5%,0.25W	01121	CB6215
AlR205	315-0331-00		RES.,FXD,CMPN:330 OHM,5%,0.25W	01121	CB3315
AlR301	307-0675-00		RES NTWK,FXD FI:9,1K OHM,2%,1.25W	01121	210A102
AlR302	307-0675-00		RES NTWK,FXD FI:9,1K OHM,2%,1.25W	01121	210A102
AlR303	315-0511-00		RES.,FXD,CMPN:510 OHM,5%,0.25W	01121	CB5115
AlR304	315-0511-00		RES.,FXD,CMPN:510 OHM,5%,0.25W	01121	CB5115
AlR401	315-0221-00		RES.,FXD,CMPN:220 OHM,5%,0.25W	01121	CB2215
AlR501	307-0596-00		RES NTWK,FXD FI:7,2.2K OHM,2%,1.0W	91637	MSP08A01222G
AlR502	307-0596-00		RES NTWK,FXD FI:7,2.2K OHM,2%,1.0W	91637	MSP08A01222G
AlR503	315-0222-00		RES.,FXD,CMPN:2.2K OHM,5%,0.25W	01121	CB2225
AlR504	315-0222-00		RES.,FXD,CMPN:2.2K OHM,5%,0.25W	01121	CB2225
AlR703	307-0675-00		RES NTWK,FXD FI:9,1K OHM,2%,1.25W	01121	210A102
AlU703	156-1252-00		MICROCIRCUIT,DI:8/3 LINE PRIORITY ENCODER	80009	156-1252-00
AlU704	156-0469-01		MICROCIRCUIT,DI:3-LINE TO 8-LINE DCDR,CHK	80009	156-0469-01

REPLACEABLE ELECTRICAL PARTS

Component No.	Tektronix Part No.	Serial/Model No. Eff Dscont	Name & Description	Mfr Code	Mfr Part Number
A2 MOTHER BOARD EXTENDER					
A2	670-7063-00	B010100 B021749	CKT BOARD ASSY:MOTHER BOARD EXTENDER (OPTION 40,41 ONLY)	80009	670-7063-00
A2	670-7063-01	B021750	CKT BOARD ASSY:MOTHER BOARD EXTENDER (OPTION 40,41 ONLY)	80009	670-7063-01
A2F6	159-0194-00	XB021750	FUSE,WIRE LEAD:5A,125V,0.125SEC	75915	255-005
A2F7	159-0194-00	XB021750	FUSE,WIRE LEAD:5A,125V,0.125SEC	75915	255-005
A2F8	159-0194-00	XB021750	FUSE,WIRE LEAD:5A,125V,0.125SEC	75915	255-005
A2F9	159-0194-00	XB021750	FUSE,WIRE LEAD:5A,125V,0.125SEC	75915	255-005
A2F10	159-0194-00	XB021750	FUSE,WIRE LEAD:5A,125V,0.125SEC	75915	255-005
A2F11	159-0194-00	XB021750	FUSE,WIRE LEAD:5A,125V,0.125SEC	75915	255-005
A2F12	159-0194-00	XB021750	FUSE,WIRE LEAD:5A,125V,0.125SEC	75915	255-005
A2F13	159-0194-00	XB021750	FUSE,WIRE LEAD:5A,125V,0.125SEC	75915	255-005
A2F14	159-0194-00	XB021750	FUSE,WIRE LEAD:5A,125V,0.125SEC	75915	255-005
A2F15	159-0194-00	XB021750	FUSE,WIRE LEAD:5A,125V,0.125SEC	75915	255-005
A2F19	159-0194-00	XB021750	FUSE,WIRE LEAD:5A,125V,0.125SEC	75915	255-005
A2J6	131-2059-01		CONN,RCPT,ELEC:CKT BD,40/80 FEM W/O EARS	00779	3-530671-0
A2J7	131-2059-01		CONN,RCPT,ELEC:CKT BD,40/80 FEM W/O EARS	00779	3-530671-0
A2J8	131-2059-01		CONN,RCPT,ELEC:CKT BD,40/80 FEM W/O EARS	00779	3-530671-0
A2J9	131-2059-01		CONN,RCPT,ELEC:CKT BD,40/80 FEM W/O EARS	00779	3-530671-0
A2J10	131-2059-01		CONN,RCPT,ELEC:CKT BD,40/80 FEM W/O EARS	00779	3-530671-0
A2J11	131-2059-01		CONN,RCPT,ELEC:CKT BD,40/80 FEM W/O EARS	00779	3-530671-0
A2J12	131-2059-01		CONN,RCPT,ELEC:CKT BD,40/80 FEM W/O EARS	00779	3-530671-0
A2J13	131-2059-01		CONN,RCPT,ELEC:CKT BD,40/80 FEM W/O EARS	00779	3-530671-0
A2J14	131-2059-01		CONN,RCPT,ELEC:CKT BD,40/80 FEM W/O EARS	00779	3-530671-0
A2J15	131-2059-01		CONN,RCPT,ELEC:CKT BD,40/80 FEM W/O EARS	00779	3-530671-0
A2J19	131-2621-00		CONN,RCPT,ELEC:HEADER,1 X 5,0.25 CTR	00779	640900-1
A2P16	131-2221-00		CONN,RCPT,ELEC:CKT BD,50 CONT,MALE	00779	2-86479-9
A2P16	131-2606-00		TERM SET,PIN:21/42 CONTACT,MALE	00779	2-86479-5
A2R1	315-0221-00		RES.,FXD,CMPSN:220 OHM,5%,0.25W	01121	CB2215
A3 PROCESSOR					
A3	672-0949-00	B010100 B019999	CKT BOARD ASSY:PROCESSOR	80009	672-0949-00
A3	672-0949-01	B020000	CKT BOARD ASSY:PROCESSOR	80009	672-0949-01
A3A1	670-6496-XX		(NOT AVAILABLE, SEE A3)		*
A3BT10	146-0040-00		BATTERY,STORAGE:2.4V,70MAH,AAA CELL	55857	MS0702405333-002
A3C11	283-0421-00		CAP.,FXD,CER DI:0.1UF,+80-20%,50V	04222	DG015E104Z
A3C31	283-0421-00		CAP.,FXD,CER DI:0.1UF,+80-20%,50V	04222	DG015E104Z
A3C75	283-0421-00		CAP.,FXD,CER DI:0.1UF,+80-20%,50V	04222	DG015E104Z
A3C135	283-0421-00		CAP.,FXD,CER DI:0.1UF,+80-20%,50V	04222	DG015E104Z
A3C155	283-0421-00		CAP.,FXD,CER DI:0.1UF,+80-20%,50V	04222	DG015E104Z
A3C156	281-0797-00		CAP.,FXD,CER DI:15PF,10%,100V	72982	8035D9AADC0G150K
A3C170	283-0421-00		CAP.,FXD,CER DI:0.1UF,+80-20%,50V	04222	DG015E104Z
A3C202	283-0421-00		CAP.,FXD,CER DI:0.1UF,+80-20%,50V	04222	DG015E104Z
A3C216	283-0421-00		CAP.,FXD,CER DI:0.1UF,+80-20%,50V	04222	DG015E104Z
A3C231	283-0421-00		CAP.,FXD,CER DI:0.1UF,+80-20%,50V	04222	DG015E104Z
A3C270	283-0421-00		CAP.,FXD,CER DI:0.1UF,+80-20%,50V	04222	DG015E104Z
A3C355	283-0421-00		CAP.,FXD,CER DI:0.1UF,+80-20%,50V	04222	DG015E104Z
A3C360	283-0421-00		CAP.,FXD,CER DI:0.1UF,+80-20%,50V	04222	DG015E104Z
A3C365	283-0421-00		CAP.,FXD,CER DI:0.1UF,+80-20%,50V	04222	DG015E104Z
A3C401	283-0421-00		CAP.,FXD,CER DI:0.1UF,+80-20%,50V	04222	DG015E104Z
A3C455	283-0421-00		CAP.,FXD,CER DI:0.1UF,+80-20%,50V	04222	DG015E104Z
A3C501	283-0422-00		CAP.,FXD,CER DI:0.047UF,+80-20%,50V	04222	DG015E473Z
A3C502	283-0422-00		CAP.,FXD,CER DI:0.047UF,+80-20%,50V	04222	DG015E473Z

REPLACEABLE ELECTRICAL PARTS

A3 PROCESSOR (CONT)

Component No.	Tektronix Part No.	Serial/Model No. Eff Dscont	Name & Description	Mfr Code	Mfr Part Number
A3C503	283-0421-00		CAP.,FXD,CER DI:0.1UF,+80-20%,50V	04222	DG015E104Z
A3C504	283-0421-00		CAP.,FXD,CER DI:0.1UF,+80-20%,50V	04222	DG015E104Z
A3C505	283-0421-00		CAP.,FXD,CER DI:0.1UF,+80-20%,50V	04222	DG015E104Z
A3C511	283-0422-00		CAP.,FXD,CER DI:0.047UF,+80-20%,50V	04222	DG015E473Z
A3C512	283-0422-00		CAP.,FXD,CER DI:0.047UF,+80-20%,50V	04222	DG015E473Z
A3C513	283-0421-00		CAP.,FXD,CER DI:0.1UF,+80-20%,50V	04222	DG015E104Z
A3C514	283-0422-00		CAP.,FXD,CER DI:0.047UF,+80-20%,50V	04222	DG015E473Z
A3C525	283-0421-00		CAP.,FXD,CER DI:0.1UF,+80-20%,50V	04222	DG015E104Z
A3C526	283-0421-00		CAP.,FXD,CER DI:0.1UF,+80-20%,50V	04222	DG015E104Z
A3C533	283-0421-00		CAP.,FXD,CER DI:0.1UF,+80-20%,50V	04222	DG015E104Z
A3C541	283-0421-00		CAP.,FXD,CER DI:0.1UF,+80-20%,50V	04222	DG015E104Z
A3C551	290-0745-00		CAP.,FXD,ELCTLT:22UF,+50-10%,25V	56289	502D225
A3C555	283-0421-00		CAP.,FXD,CER DI:0.1UF,+80-20%,50V	04222	DG015E104Z
A3C560	283-0421-00		CAP.,FXD,CER DI:0.1UF,+80-20%,50V	04222	DG015E104Z
A3C565	283-0421-00		CAP.,FXD,CER DI:0.1UF,+80-20%,50V	04222	DG015E104Z
A3C570	283-0421-00		CAP.,FXD,CER DI:0.1UF,+80-20%,50V	04222	DG015E104Z
A3C575	283-0421-00		CAP.,FXD,CER DI:0.1UF,+80-20%,50V	04222	DG015E104Z
A3C576	283-0421-00		CAP.,FXD,CER DI:0.1UF,+80-20%,50V	04222	DG015E104Z
A3CR9	152-0141-02		SEMICONV DEVICE:SILICON,30V,150MA	01295	1N4152R
A3CR10	152-0141-02		SEMICONV DEVICE:SILICON,30V,150MA	01295	1N4152R
A3CR11	152-0141-02		SEMICONV DEVICE:SILICON,30V,150MA	01295	1N4152R
A3CR525	152-0141-02		SEMICONV DEVICE:SILICON,30V,150MA	01295	1N4152R
A3CR526	152-0141-02		SEMICONV DEVICE:SILICON,30V,150MA	01295	1N4152R
A3J103	131-1789-00		CONN,RCPT,ELEC:RT-ANGLE,2/100.025 SQ PINS	22526	65268-008
A3J125	131-0608-00	-----	TERMINAL,PIN:0.365 L X 0.025 PH BRZ GOLD (QUANTITY OF 2)	22526	47357
A3J150	131-0608-00	-----	TERMINAL,PIN:0.365 L X 0.025 PH BRZ GOLD (QUANTITY OF 2)	22526	47357
A3J226	131-0608-00	-----	TERMINAL,PIN:0.365 L X 0.025 PH BRZ GOLD (QUANTITY OF 5)	22526	47357
A3J326	131-0608-00	-----	TERMINAL,PIN:0.365 L X 0.025 PH BRZ GOLD (QUANTITY OF 5)	22526	47357
A3J426	131-0608-00	-----	TERMINAL,PIN:0.365 L X 0.025 PH BRZ GOLD (QUANTITY OF 5)	22526	47357
A3J427	131-0608-00	-----	TERMINAL,PIN:0.365 L X 0.025 PH BRZ GOLD (QUANTITY OF 5)	22526	47357
A3J522	131-0608-00	-----	TERMINAL,PIN:0.365 L X 0.025 PH BRZ GOLD (QUANTITY OF 3)	22526	47357
A3R9	315-0271-00		RES.,FXD,CMPSN:270 OHM,5%,0.25W	01121	CB2715
A3R11	315-0271-00		RES.,FXD,CMPSN:270 OHM,5%,0.25W	01121	CB2715
A3R12	315-0751-00		RES.,FXD,CMPSN:750 OHM,5%,0.25W	01121	CB7515
A3R13	315-0751-00		RES.,FXD,CMPSN:750 OHM,5%,0.25W	01121	CB7515
A3R31	307-0502-00		RES NTWK,FXD,FI:(9) 1.8K OHM,20%,0.125W	91637	MSP10A01-182M
A3R55	307-0650-00		RES NTWK,FXD,FI:9,2.7K OHM,5%,0.150W	32997	4310R-101-272
A3R175	315-0272-00		RES.,FXD,CMPSN:2.7K OHM,5%,0.25W	01121	CB2725
A3R216	307-0637-00		RES NTWK,FXD,FI:5,2K OHM,2%,0.125W	01121	206A202
A3R250	307-0650-00		RES NTWK,FXD,FI:9,2.7K OHM,5%,0.150W	32997	4310R-101-272
A3R350	307-0650-00		RES NTWK,FXD,FI:9,2.7K OHM,5%,0.150W	32997	4310R-101-272
A3R440	307-0446-00		RES,NTWK,FXD FI:10K OHM,20%,(9) RES	91637	MSP10A01-103M
A3R525	315-0102-00		RES.,FXD,CMPSN:1K OHM,5%,0.25W	01121	CB1025
A3R526	315-0102-00		RES.,FXD,CMPSN:1K OHM,5%,0.25W	01121	CB1025
A3R550	307-0446-00		RES,NTWK,FXD FI:10K OHM,20%,(9) RES	91637	MSP10A01-103M
A3U25	156-0956-02		MICROCIRCUIT,DI:OCTAL BFR W/3STATE OUT	01295	SN74LS244NP3
A3U35	160-0843-00		MICROCIRCUIT,DI:MICROCOMPUTER,PRGM & SCRN	80009	160-0843-00
A3U45	156-1416-00		MICROCIRCUIT,DI:16 BIT UP,SCREENED	34649	D8086
A3U65	156-0385-02		MICROCIRCUIT,DI:HEX INVERTER	01295	SN74LS04
A3U70	156-0473-02		MICROCIRCUIT,DI:DUAL 5-INP NAND GATE,SCRN	27014	DM8092N/A+

REPLACEABLE ELECTRICAL PARTS

A3 PROCESSOR (CONT)

Component No.	Tektronix Part No.	Serial/Model No. Eff Dscont	Name & Description	Mfr Code	Mfr Part Number
A3U75	156-0479-02		MICROCIRCUIT,DI:QUAD 2-INP ORGATE	01295	SN74LS32NP3
A3U101	156-0382-02		MICROCIRCUIT,DI:QUAD 2-INP NAND GATE	01295	SN74LS00
A3U115	156-0041-05		MICROCIRCUIT,DI:DUAL D-TYPE FF,BURN-IN	01295	SN7474
A3U125	156-0385-02		MICROCIRCUIT,DI:HEX INVERTER	01295	SN74LS04
A3U130	156-0469-02		MICROCIRCUIT,DI:3/8 LINE DCDR	01295	SN74LS138NP3
A3U135	156-0140-02		MICROCIRCUIT,DI:HEX BUFFERS W/OC HV OUT	27014	DM8017NA+/JA+
A3U140	156-0985-01		MICROCIRCUIT,DI:DUAL 5 INPUT NOR GATE,SCRN	04713	SN74LS260
A3U145	156-0478-02		MICROCIRCUIT,DI:DUAL 4 INP & GATE,BURN-IN	01295	SN74LS21NP3
A3U150	156-1065-01		MICROCIRCUIT,DI:OCTAL D TYPE TRANS LATCHES	34335	AM74LS373
A3U155	156-1428-01		MICROCIRCUIT,DI:CLOCK GENERATOR & DRVR	34649	D8284
A3U165	156-0694-02		MICROCIRCUIT,DI:DCDR/3 LINE TO 8 LINE,SCRN	07263	74S138DCQR
A3U170	156-0481-02		MICROCIRCUIT,DI:TRIPLE 3 INP & GATE	27014	DM74LS11NA+
A3U175	156-1059-01		MICROCIRCUIT,DI:DUAL J-K EDGETRIGGERED	01295	SN74LS109A
A3U201	156-0478-02		MICROCIRCUIT,DI:DUAL 4 INP & GATE,BURN-IN	01295	SN74LS21NP3
A3U202	156-0382-02		MICROCIRCUIT,DI:QUAD 2-INP NAND GATE	01295	SN74LS00
A3U215	156-0383-02		MICROCIRCUIT,DI:QUAD 2-INP NOR GATE	01295	SN74LS02
A3U216	156-0385-02		MICROCIRCUIT,DI:HEX INVERTER	01295	SN74LS04
A3U225	156-0383-02		MICROCIRCUIT,DI:QUAD 2-INP NOR GATE	01295	SN74LS02
A3U226	156-0865-02		MICROCIRCUIT,DI:OCTAL D-TYPE FF W/CLEAR	01295	SN74LS273NP3
A3U230	156-1036-01		MICROCIRCUIT,DI:PRGM INTERVALTIMER	34649	QD8253
A3U231	160-1013-01	B010100 B019999	MICROCIRCUIT,DI:4096 X 8 EPROM,PRGM	80009	160-1013-01
A3U231	160-1013-02	B020000	MICROCIRCUIT,DI:4096 X 8 EPROM,PRGM	80009	160-1013-02
A3U235	156-1172-01		MICROCIRCUIT,DI:DUAL 4 BIT CNTR,BURN IN	01295	SN74LS393
A3U240	156-0392-03		MICROCIRCUIT,DI:QUAD LATCH W/CLEAR	01295	SN74S175NP3
A3U241	160-1012-01	B010100 B019999	MICROCIRCUIT,DI:4096 X 8 EPROM,PRGM	80009	160-1012-01
A3U241	160-1012-02	B020000	MICROCIRCUIT,DI:4096 X 8 EPROM,PRGM	80009	160-1012-02
A3U245	156-0385-02		MICROCIRCUIT,DI:HEX INVERTER	01295	SN74LS04
A3U250	156-1065-01		MICROCIRCUIT,DI:OCTAL D TYPE TRANS LATCHES	34335	AM74LS373
A3U255	156-1065-01		MICROCIRCUIT,DI:OCTAL D TYPE TRANS LATCHES	34335	AM74LS373
A3U260	156-0465-02		MICROCIRCUIT,DI:8 INP NAND GATE	01295	SN74LS30NP3
A3U265	156-0382-02		MICROCIRCUIT,DI:QUAD 2-INP NAND GATE	01295	SN74LS00
A3U270	156-0386-02		MICROCIRCUIT,DI:TRIPLE 3-INPUT NAND GATE	01295	SN74LS10
A3U275	156-1258-01		MICROCIRCUIT,DI:DUAL J-K NEG-EDGE TRIG FF	01295	SN74LS112
A3U301	156-1460-00		MICROCIRCUIT,DI:ENHANCED PRGCOMM INTFC	18324	2661-2I/CP2752
A3U325	156-0467-02		MICROCIRCUIT,DI:QUAD 2-INP NAND BFR,SCRN	01295	SN74LS38
A3U330	160-1003-01		MICROCIRCUIT,DI:4096 X 8 EPROM,PRGM	80009	160-1003-01
A3U340	160-1002-01		MICROCIRCUIT,DI:4096 X 8 EPROM,PRGM	80009	160-1002-01
A3U350	156-1111-02		MICROCIRCUIT,DI:OCTAL BUS TRANSCEIVERS	01295	SN74LS245JP3
A3U355	156-0118-03		MICROCIRCUIT,DI:1 DUAL J-K FF,BURN-IN	01295	SN74S112JP3
A3U360	156-0690-03		MICROCIRCUIT,DI:QUAD 2 INP NOR GATE,BURN IN	01295	SN74S02
A3U365	156-0722-02		MICROCIRCUIT,DI:TPL 3-INPUT POS NAND GATE	04713	SN74LS12NDS
A3U370	156-1204-01		MICROCIRCUIT,DI:INTERRUPT CONTROLLER,SCRN	34649	QD8259A
A3U401	156-0391-02		MICROCIRCUIT,DI:HEX LATCH W/CLEAR	01295	SN74LS174
A3U415	156-0845-02		MICROCIRCUIT,DI:6 BIT COMPARATOR,BURN-IN	80009	156-0845-02
A3U425	156-0720-02		MICROCIRCUIT,DI:HEX DRVR,4 TO2 LINE	01295	SN74LS368
A3U430	160-1001-01		MICROCIRCUIT,DI:4096 X 8 EPROM,PRGM	80009	160-1001-01
A3U431	160-1011-01		MICROCIRCUIT,DI:4096 X 8 EPROM,PRGM	80009	160-1011-01
A3U440	160-1000-01		MICROCIRCUIT,DI:4096 X 8 EPROM,PRGM	80009	160-1000-01
A3U441	160-1010-01		MICROCIRCUIT,DI:4096 X 8 EPROM,PRGM	80009	160-1010-01
A3U450	156-1111-02		MICROCIRCUIT,DI:OCTAL BUS TRANSCEIVERS	01295	SN74LS245JP3
A3U455	156-0419-02		MICROCIRCUIT,DI:DUAL 4 INP NAND LINE DRVR	07263	74S140
A3U460	156-0955-02		MICROCIRCUIT,DI:OCTAL BFR W/3STATE OUT	04713	SN74LS241
A3U465	156-0385-02		MICROCIRCUIT,DI:HEX INVERTER	01295	SN74LS04
A3U470	156-0140-02		MICROCIRCUIT,DI:HEX BUFFERS W/OC HV OUT	27014	DM8017NA+/JA+
A3U475	156-0473-02		MICROCIRCUIT,DI:DUAL 5-INP NAND GATE,SCRN	27014	DM8092N/A+
A3U501	156-0878-01		MICROCIRCUIT,DI:QUAD LINE RCVR,SCRN	80009	156-0878-01
A3U515	156-0878-01		MICROCIRCUIT,DI:QUAD LINE RCVR,SCRN	80009	156-0878-01

REPLACEABLE ELECTRICAL PARTS

A3 PROCESSOR (CONT)

Component No.	Tektronix Part No.	Serial/Model No. Eff Dscont	Name & Description	Mfr Code	Mfr Part Number
A3U525	156-0879-01		MICROCIRCUIT,DI:QUAD LINE DRIVER,SCRN	80009	156-0879-01
A3U530	156-0479-02		MICROCIRCUIT,DI:QUAD 2-INP ORGATE	01295	SN74LS32NP3
A3U535	156-0887-01		MICROCIRCUIT,DI:256 X 4 SRAM,SCRN	80009	156-0887-01
A3U536	156-0887-01		MICROCIRCUIT,DI:256 X 4 SRAM,SCRN	80009	156-0887-01
A3U540	156-0887-01		MICROCIRCUIT,DI:256 X 4 SRAM,SCRN	80009	156-0887-01
A3U541	156-0887-01		MICROCIRCUIT,DI:256 X 4 SRAM,SCRN	80009	156-0887-01
A3U550	156-1111-02		MICROCIRCUIT,DI:OCTAL BUS TRANSCEIVERS	01295	SN74LS245JP3
A3U555	156-1111-02		MICROCIRCUIT,DI:OCTAL BUS TRANSCEIVERS	01295	SN74LS245JP3
A3U560	156-1427-01		MICROCIRCUIT,DI:BUS CONTROLLER,SCREENED	34649	QD8288
A3U565	156-1065-01		MICROCIRCUIT,DI:OCTAL D TYPE TRANS LATCHES	34335	AM74LS373
A3U570	156-1065-01		MICROCIRCUIT,DI:OCTAL D TYPE TRANS LATCHES	34335	AM74LS373
A3U575	156-1065-01		MICROCIRCUIT,DI:OCTAL D TYPE TRANS LATCHES	34335	AM74LS373
A3Y155	158-0135-00		XTAL UNIT,QTZ:14.7456 MHZ,0.01%,SERIES (XTAL UNIT REQUIRES FOAM ADHESIVE)	01807	OBD

REPLACEABLE ELECTRICAL PARTS

Component No.	Tektronix Part No.	Serial/Model No. Eff Dscont	Name & Description	Mfr Code	Mfr Part Number
A4 KEYBOARD					
A4	119-1305-03		KEYBOARD, CMPTR: (STANDARD, OPTION 4A ONLY)	52833	65-2035
A4	119-1394-00		KEYBOARD ASSY: SWEDISH & DANISH (OPTION 4C, 4F ONLY)	51181	66-02035-003
A4	119-1395-00		KEYBOARD ASSY: APL (OPTION 4E ONLY)	51181	66-02035-002
A4C1	118-0964-00		CAP., FXD, ELCTLT: 10UF, 15V, TANTALUM	80009	118-0964-00
A4C2	118-0963-00		CAP., FXD, ELCTLT: 2.2UF, 16V, TANTALUM	80009	118-0963-00
A4C3	118-0965-00		CAP., FXD, CER DI: 0.033UF, 100V	80009	118-0965-00
A4C4	118-0965-00		CAP., FXD, CER DI: 0.033UF, 100V	80009	118-0965-00
A4C5	118-0965-00		CAP., FXD, CER DI: 0.033UF, 100V	80009	118-0965-00
A4C6	118-0965-00		CAP., FXD, CER DI: 0.033UF, 100V	80009	118-0965-00
A4C7	290-0512-00		CAP., FXD, ELCTLT: 22UF, 20%, 15V	56289	196D226X0015KA1
A4C8	118-0965-00		CAP., FXD, CER DI: 0.033UF, 100V	80009	118-0965-00
A4C9	118-0965-00		CAP., FXD, CER DI: 0.033UF, 100V	80009	118-0965-00
A4C10	118-0965-00		CAP., FXD, CER DI: 0.033UF, 100V	80009	118-0965-00
A4C11	118-0965-00		CAP., FXD, CER DI: 0.033UF, 100V	80009	118-0965-00
A4C12	118-0965-00		CAP., FXD, CER DI: 0.033UF, 100V	80009	118-0965-00
A4C13	118-0965-00		CAP., FXD, CER DI: 0.033UF, 100V	80009	118-0965-00
A4C14	118-0965-00		CAP., FXD, CER DI: 0.033UF, 100V	80009	118-0965-00
A4C15	118-0965-00		CAP., FXD, CER DI: 0.033UF, 100V	80009	118-0965-00
A4C16	118-0965-00		CAP., FXD, CER DI: 0.033UF, 100V	80009	118-0965-00
A4C18	118-0964-00		CAP., FXD, ELCTLT: 10UF, 15V, TANTALUM	80009	118-0964-00
A4C19	281-0759-00		CAP., FXD, CER DI: 22PF, 10%, 100V	72982	8035D9AADC1G220K
A4C20	281-0759-00		CAP., FXD, CER DI: 22PF, 10%, 100V	72982	8035D9AADC1G220K
A4C21	281-0759-00		CAP., FXD, CER DI: 22PF, 10%, 100V	72982	8035D9AADC1G220K
A4C22	281-0759-00		CAP., FXD, CER DI: 22PF, 10%, 100V	72982	8035D9AADC1G220K
A4C23	281-0759-00		CAP., FXD, CER DI: 22PF, 10%, 100V	72982	8035D9AADC1G220K
A4C24	281-0759-00		CAP., FXD, CER DI: 22PF, 10%, 100V	72982	8035D9AADC1G220K
A4C25	281-0759-00		CAP., FXD, CER DI: 22PF, 10%, 100V	72982	8035D9AADC1G220K
A4C26	281-0759-00		CAP., FXD, CER DI: 22PF, 10%, 100V	72982	8035D9AADC1G220K
A4C27	283-0111-00		CAP., FXD, CER DI: 0.1UF, 20%, 50V	72982	8121-N088Z5U104M
A4DS1	118-0966-00		LT EMITTING DIO: RED, 40MA MAX, 1.5V	52833	21-05053-00
A4DS2	118-0966-00		LT EMITTING DIO: RED, 40MA MAX, 1.5V	52833	21-05053-00
A4DS3	118-0966-00		LT EMITTING DIO: RED, 40MA MAX, 1.5V	52833	21-05053-00
A4DS4	118-0966-00		LT EMITTING DIO: RED, 40MA MAX, 1.5V	52833	21-05053-00
A4DS6	118-0967-00		LT EMITTING DIO: ORANGE, 630NM, 35MA MAX, 2.4V	52833	21-57152-00
A4DS7	118-0967-00		LT EMITTING DIO: ORANGE, 630NM, 35MA MAX, 2.4V	52833	21-57152-00
A4DS8	118-0967-00		LT EMITTING DIO: ORANGE, 630NM, 35MA MAX, 2.4V	52833	21-57152-00
A4DS9	118-0967-00		LT EMITTING DIO: ORANGE, 630NM, 35MA MAX, 2.4V	52833	21-57152-00
A4DS18	118-0967-00		LT EMITTING DIO: ORANGE, 630NM, 35MA MAX, 2.4V	52833	21-57152-00
A4DS19	118-0967-00		LT EMITTING DIO: ORANGE, 630NM, 35MA MAX, 2.4V	52833	21-57152-00
A4DS20	118-0967-00		LT EMITTING DIO: ORANGE, 630NM, 35MA MAX, 2.4V	52833	21-57152-00
A4Q1	151-0254-00		TRANSISTOR: SILICON, NPN	03508	X38L3118
A4Q2	151-0301-00		TRANSISTOR: SILICON, PNP	27014	2N2907A
A4Q3	151-0302-00		TRANSISTOR: SILICON, NPN	07263	S038487
A4R1	315-0224-00		RES., FXD, CMPSN: 220K OHM, 5%, 0.25W	01121	CB2245
A4R2	315-0563-00		RES., FXD, CMPSN: 56K OHM, 5%, 0.25W	01121	CB5635
A4R3	315-0222-00		RES., FXD, CMPSN: 2.2K OHM, 5%, 0.25W	01121	CB2225
A4R4	315-0222-00		RES., FXD, CMPSN: 2.2K OHM, 5%, 0.25W	01121	CB2225
A4R5	315-0183-00		RES., FXD, CMPSN: 18K OHM, 5%, 0.25W	01121	CB1835
A4R6	315-0223-00		RES., FXD, CMPSN: 22K OHM, 5%, 0.25W	01121	CB2235
A4R7	315-0200-00		RES., FXD, CMPSN: 20 OHM, 5%, 0.25W	01121	CB2005
A4R8	315-0820-00		RES., FXD, CMPSN: 82 OHM, 5%, 0.25W	01121	CB8205
A4R9	315-0682-00		RES., FXD, CMPSN: 6.8K OHM, 5%, 0.25W	01121	CB6825

REPLACEABLE ELECTRICAL PARTS

A4 KEYBOARD (CONT)

Component No.	Tektronix Part No.	Serial/Model No. Eff Dscont	Name & Description	Mfr Code	Mfr Part Number
A4R10	322-0184-00		RES.,FXD,FILM:806 OHM,1%,0.25W	75042	CEBT0-8060F
A4R11	315-0333-00		RES.,FXD,CMPNS:33K OHM,5%,0.25W	01121	CB3335
A4R12	315-0820-00		RES.,FXD,CMPNS:82 OHM,5%,0.25W	01121	CB8205
A4R13	315-0820-00		RES.,FXD,CMPNS:82 OHM,5%,0.25W	01121	CB8205
A4R14	315-0332-00		RES.,FXD,CMPNS:3.3K OHM,5%,0.25W	01121	CB3325
A4R15	315-0104-00		RES.,FXD,CMPNS:100K OHM,5%,0.25W	01121	CB1045
A4R16	315-0103-00		RES.,FXD,CMPNS:10K OHM,5%,0.25W	01121	CB1035
A4R17	315-0104-00		RES.,FXD,CMPNS:100K OHM,5%,0.25W	01121	CB1045
A4R18	315-0103-00		RES.,FXD,CMPNS:10K OHM,5%,0.25W	01121	CB1035
A4R19	315-0104-00		RES.,FXD,CMPNS:100K OHM,5%,0.25W	01121	CB1045
A4R20	315-0103-00		RES.,FXD,CMPNS:10K OHM,5%,0.25W	01121	CB1035
A4R21	315-0104-00		RES.,FXD,CMPNS:100K OHM,5%,0.25W	01121	CB1045
A4R22	315-0103-00		RES.,FXD,CMPNS:10K OHM,5%,0.25W	01121	CB1035
A4R23	315-0100-00		RES.,FXD,CMPNS:10 OHM,5%,0.25W	01121	CB1005
A4R24	315-0100-00		RES.,FXD,CMPNS:10 OHM,5%,0.25W	01121	CB1005
A4R25	315-0332-00		RES.,FXD,CMPNS:3.3K OHM,5%,0.25W	01121	CB3325
A4R26	315-0332-00		RES.,FXD,CMPNS:3.3K OHM,5%,0.25W	01121	CB3325
A4R27	315-0332-00		RES.,FXD,CMPNS:3.3K OHM,5%,0.25W	01121	CB3325
A4R28	315-0332-00		RES.,FXD,CMPNS:3.3K OHM,5%,0.25W	01121	CB3325
A4R29	315-0820-00		RES.,FXD,CMPNS:82 OHM,5%,0.25W	01121	CB8205
A4RX1	307-0540-00		RES,NTWK,FXD,FI:(5) 1K OHM,10%,0.7W	01121	206A102
A4RX3	307-0792-00		RES NTWK,FXD,FI:7,82 OHM,2%,0.15W	11236	750-81-R82
A4U1	156-0402-00		MICROCIRCUIT,LI:TIMER	27014	LM555CN
A4U2	156-0645-02		MICROCIRCUIT,DI:HEX INV ST NAND GATES,SCRN	01295	SN74LS14
A4U3	156-0392-00		MICROCIRCUIT,DI:QUAD LATCH W/CLEAR	34335	SN74LS175N OR J
A4U4	118-0941-00		MICROCIRCUIT,LI:KYBD DETECTOR,CAPACITIVE	52833	22-00908-003
A4U5	118-0973-00		MICROCIRCUIT,DI:TTL,X-LINE DRIVER	52833	22-00950-003
A4U6	156-0153-02		MICROCIRCUIT,DI:HEX INVERTER BUFFER	27014	DM8006
A4U7	156-0874-02		MICROCIRCUIT,DI:8 BIT ADDRESSABLE LCH	80009	156-0874-02
A4U8	156-0874-02		MICROCIRCUIT,DI:8 BIT ADDRESSABLE LCH	80009	156-0874-02
A4U9	156-0153-02		MICROCIRCUIT,DI:HEX INVERTER BUFFER	27014	DM8006
A4U10	156-0961-00		MICROCIRCUIT,DI:QUAD 2-INP NAND ST	80009	156-0961-00
A4U11	156-0480-00		MICROCIRCUIT,DI:QUAD 2-INPUT AND GATE	01295	SN74LS08(N OR J)

REPLACEABLE ELECTRICAL PARTS

Component No.	Tektronix Part No.	Serial/Model No. Eff Dscont	Name & Description	Mfr Code	Mfr Part Number
A5 RAM ROM					
A5	672-0950-00	B010100 B010169	CKT BOARD ASSY:RAM ROM	80009	672-0950-00
A5	672-0950-01	B010170 B010219	CKT BOARD ASSY:RAM ROM	80009	672-0950-01
A5	672-0950-02	B010220	CKT BOARD ASSY:RAM ROM	80009	672-0950-02
A5A1	670-6940-XX		(NOT AVAILABLE, SEE A5)		*
A5C11	283-0421-00		CAP.,FXD,CER DI:0.1UF,+80-20%,50V	04222	DG015E104Z
A5C21	283-0421-00		CAP.,FXD,CER DI:0.1UF,+80-20%,50V	04222	DG015E104Z
A5C31	283-0421-00		CAP.,FXD,CER DI:0.1UF,+80-20%,50V	04222	DG015E104Z
A5C41	283-0421-00		CAP.,FXD,CER DI:0.1UF,+80-20%,50V	04222	DG015E104Z
A5C51	283-0421-00		CAP.,FXD,CER DI:0.1UF,+80-20%,50V	04222	DG015E104Z
A5C61	283-0421-00		CAP.,FXD,CER DI:0.1UF,+80-20%,50V	04222	DG015E104Z
A5C71	283-0421-00		CAP.,FXD,CER DI:0.1UF,+80-20%,50V	04222	DG015E104Z
A5C81	283-0421-00		CAP.,FXD,CER DI:0.1UF,+80-20%,50V	04222	DG015E104Z
A5C95	283-0421-00		CAP.,FXD,CER DI:0.1UF,+80-20%,50V	04222	DG015E104Z
A5C111	283-0421-00		CAP.,FXD,CER DI:0.1UF,+80-20%,50V	04222	DG015E104Z
A5C121	283-0421-00		CAP.,FXD,CER DI:0.1UF,+80-20%,50V	04222	DG015E104Z
A5C131	283-0421-00		CAP.,FXD,CER DI:0.1UF,+80-20%,50V	04222	DG015E104Z
A5C141	283-0421-00		CAP.,FXD,CER DI:0.1UF,+80-20%,50V	04222	DG015E104Z
A5C151	283-0421-00		CAP.,FXD,CER DI:0.1UF,+80-20%,50V	04222	DG015E104Z
A5C161	283-0421-00		CAP.,FXD,CER DI:0.1UF,+80-20%,50V	04222	DG015E104Z
A5C171	283-0421-00		CAP.,FXD,CER DI:0.1UF,+80-20%,50V	04222	DG015E104Z
A5C181	283-0421-00		CAP.,FXD,CER DI:0.1UF,+80-20%,50V	04222	DG015E104Z
A5C353	283-0421-00		CAP.,FXD,CER DI:0.1UF,+80-20%,50V	04222	DG015E104Z
A5C360	283-0421-00		CAP.,FXD,CER DI:0.1UF,+80-20%,50V	04222	DG015E104Z
A5C365	283-0421-00		CAP.,FXD,CER DI:0.1UF,+80-20%,50V	04222	DG015E104Z
A5C373	283-0421-00		CAP.,FXD,CER DI:0.1UF,+80-20%,50V	04222	DG015E104Z
A5C379	281-0797-00		CAP.,FXD,CER DI:15PF,10%,100V	72982	8035D9AADC0G150K
A5C381	283-0421-00		CAP.,FXD,CER DI:0.1UF,+80-20%,50V	04222	DG015E104Z
A5C409	283-0421-00		CAP.,FXD,CER DI:0.1UF,+80-20%,50V	04222	DG015E104Z
A5C453	283-0421-00		CAP.,FXD,CER DI:0.1UF,+80-20%,50V	04222	DG015E104Z
A5C460	283-0421-00		CAP.,FXD,CER DI:0.1UF,+80-20%,50V	04222	DG015E104Z
A5C465	283-0421-00		CAP.,FXD,CER DI:0.1UF,+80-20%,50V	04222	DG015E104Z
A5C483	283-0421-00		CAP.,FXD,CER DI:0.1UF,+80-20%,50V	04222	DG015E104Z
A5C489	283-0421-00		CAP.,FXD,CER DI:0.1UF,+80-20%,50V	04222	DG015E104Z
A5C493	283-0421-00		CAP.,FXD,CER DI:0.1UF,+80-20%,50V	04222	DG015E104Z
A5C496	283-0421-00		CAP.,FXD,CER DI:0.1UF,+80-20%,50V	04222	DG015E104Z
A5C561	290-0745-00		CAP.,FXD,ELCTLT:22UF,+50-10%,25V	56289	502D225
A5CR490	152-0066-00		SEMICONV DEVICE:SILICON,400V,750MA	14433	LG4016
A5J121	131-0608-00		TERMINAL,PIN:0.365 L X 0.025 PH BRZ GOLD (QUANTITY OF 5)	22526	47357
A5J122	131-0608-00		TERMINAL,PIN:0.365 L X 0.025 PH BRZ GOLD (QUANTITY OF 5)	22526	47357
A5J123	131-0608-00		TERMINAL,PIN:0.365 L X 0.025 PH BRZ GOLD (QUANTITY OF 5)	22526	47357
A5J124	131-0608-00		TERMINAL,PIN:0.365 L X 0.025 PH BRZ GOLD (QUANTITY OF 5)	22526	47357
A5J125	131-0608-00		TERMINAL,PIN:0.365 L X 0.025 PH BRZ GOLD (QUANTITY OF 5)	22526	47357
A5J126	131-0608-00		TERMINAL,PIN:0.365 L X 0.025 PH BRZ GOLD (QUANTITY OF 5)	22526	47357
A5J127	131-0608-00		TERMINAL,PIN:0.365 L X 0.025 PH BRZ GOLD (QUANTITY OF 5)	22526	47357
A5J128	131-0608-00		TERMINAL,PIN:0.365 L X 0.025 PH BRZ GOLD (QUANTITY OF 5)	22526	47357
A5J129	131-0608-00		TERMINAL,PIN:0.365 L X 0.025 PH BRZ GOLD (QUANTITY OF 3)	22526	47357

REPLACEABLE ELECTRICAL PARTS

A5 RAM ROM (CONT)

Component No.	Tektronix Part No.	Serial/Model No. Eff Dscont	Name & Description	Mfr Code	Mfr Part Number
A5L380	108-0088-00		COIL, RF: FIXED, 3.35UH	80009	108-0088-00
A5R91	307-0445-00		RES NTWK, FXD, FI: 4.7K OHM, 20%, (9) RES	91637	MSP10A01-472M
A5R191	307-0445-00		RES NTWK, FXD, FI: 4.7K OHM, 20%, (9) RES	91637	MSP10A01-472M
A5R192	131-0566-00	XB010360	BUS CONDUCTOR: DUMMY RES, 2.375, 22 AWG	55210	L-2007-1
A5R193	131-0566-00	XB010360	BUS CONDUCTOR: DUMMY RES, 2.375, 22 AWG	55210	L-2007-1
A5R374	315-0470-00		RES., FXD, CMPSN: 47 OHM, 5%, 0.25W	01121	CB4705
A5R375	315-0470-00		RES., FXD, CMPSN: 47 OHM, 5%, 0.25W	01121	CB4705
A5R376	315-0821-00		RES., FXD, CMPSN: 820 OHM, 5%, 0.25W	01121	CB8215
A5R378	315-0821-00		RES., FXD, CMPSN: 820 OHM, 5%, 0.25W	01121	CB8215
A5R383	315-0102-00		RES., FXD, CMPSN: 1K OHM, 5%, 0.25W	01121	CB1025
A5R390	315-0472-00		RES., FXD, CMPSN: 4.7K OHM, 5%, 0.25W	01121	CB4725
A5R393	315-0472-00		RES., FXD, CMPSN: 4.7K OHM, 5%, 0.25W	01121	CB4725
A5R396	315-0132-00		RES., FXD, CMPSN: 1.3K OHM, 5%, 0.25W	01121	CB1325
A5R455	315-0102-00		RES., FXD, CMPSN: 1K OHM, 5%, 0.25W	01121	CB1025
A5R482	315-0102-00		RES., FXD, CMPSN: 1K OHM, 5%, 0.25W	01121	CB1025
A5R490	315-0472-00		RES., FXD, CMPSN: 4.7K OHM, 5%, 0.25W	01121	CB4725
A5R491	315-0331-00		RES., FXD, CMPSN: 330 OHM, 5%, 0.25W	01121	CB3315
A5R492	315-0331-00		RES., FXD, CMPSN: 330 OHM, 5%, 0.25W	01121	CB3315
A5U11	160-0981-01		MICROCIRCUIT, DI: 4096 X 8 EPROM, PRGM (OPTION 4A, 4C, 4E, 4F ONLY)	80009	160-0981-01
A5U21	160-0985-01		MICROCIRCUIT, DI: 4096 X 8 EPROM, PRGM (OPTION 01 ONLY)	80009	160-0985-01
A5U31	160-0987-01		MICROCIRCUIT, DI: 4096 X 8 EPROM, PRGM	80009	160-0987-01
A5U41	160-0989-01		MICROCIRCUIT, DI: 4096 X 8 EPROM, PRGM	80009	160-0989-01
A5U71	160-1007-01		MICROCIRCUIT, DI: 4096 X 8 EPROM, PRGM	80009	160-1007-01
A5U81	160-1009-01		MICROCIRCUIT, DI: 4096 X 8 EPROM, PRGM	80009	160-1009-01
A5U95	156-0694-02		MICROCIRCUIT, DI: DCDR/3 LINE TO 8 LINE, SCRNM	07263	74S138DCQR
A5U111	160-0980-01		MICROCIRCUIT, DI: 4096 X 8 EPROM, PRGM (OPTION 4A, 4C, 4E, 4F ONLY)	80009	160-0980-01
A5U121	160-0984-01		MICROCIRCUIT, DI: 4096 X 8 EPROM, PRGM (OPTION 01 ONLY)	80009	160-0984-01
A5U131	160-0986-01		MICROCIRCUIT, DI: 4096 X 8 EPROM, PRGM	80009	160-0986-01
A5U141	160-0988-01		MICROCIRCUIT, DI: 4096 X 8 EPROM, PRGM	80009	160-0988-01
A5U171	160-1006-01		MICROCIRCUIT, DI: 4096 X 8 EPROM, PRGM	80009	160-1006-01
A5U181	160-1008-01		MICROCIRCUIT, DI: 4096 X 8 EPROM, PRGM	80009	160-1008-01
A5U193	156-0331-03	B010100 B010359X	MICROCIRCUIT, DI: DUAL D TYPE POS EDGE TRIG	80009	156-0331-03
A5U194	156-0323-02	XB010170	MICROCIRCUIT, DI: HEX INVERTER, BURN-IN	01295	SN74S04
A5U195	156-0304-02		MICROCIRCUIT, DI: DUAL 4 INP NAND GATE	01295	SN74S20
A5U353	156-1065-01		MICROCIRCUIT, DI: OCTAL D TYPE TRANS LATCHES	34335	AM74LS373
A5U360	156-0956-02		MICROCIRCUIT, DI: OCTAL BFR W/3STATE OUT	01295	SN74LS244NP3
A5U365	156-0956-02		MICROCIRCUIT, DI: OCTAL BFR W/3STATE OUT	01295	SN74LS244NP3
A5U373	156-0739-02		MICROCIRCUIT, DI: QUAD 2 INP ORGATE, SCRNM	01295	SN74S32
A5U381	156-0180-04		MICROCIRCUIT, DI: QUAD 2-INPUT NAND GATE	01295	SN74S00NP3
A5U383	156-0323-02		MICROCIRCUIT, DI: HEX INVERTER, BURN-IN	01295	SN74S04
A5U389	156-0035-02		MICROCIRCUIT, DI: SGL 8 INPUT NAND GATE	27014	DM8030NA+/JA+
A5U393	156-0739-02		MICROCIRCUIT, DI: QUAD 2 INP ORGATE, SCRNM	01295	SN74S32
A5U396	156-0707-03		MICROCIRCUIT, DI: QUAD 2 INP EXCL OR GATE	07263	74S86
A5U453	156-1065-01		MICROCIRCUIT, DI: OCTAL D TYPE TRANS LATCHES	34335	AM74LS373
A5U460	156-0956-02		MICROCIRCUIT, DI: OCTAL BFR W/3STATE OUT	01295	SN74LS244NP3
A5U465	156-0956-02		MICROCIRCUIT, DI: OCTAL BFR W/3STATE OUT	01295	SN74LS244NP3
A5U473	156-1442-00	B010100 B010359	MICROCIRCUIT, DI: DYNAMIC RAM CONT, SCRNM	18324	D8202
A5U473	156-1599-00	B010360	MICROCIRCUIT, DI: STTL, DYNAMIC RAM CONTROL	34649	D8202A
A5U483	156-1179-01		MICROCIRCUIT, DI: OCTAL BFR, W/3STATE OUT	01295	SN74S241 JP4
A5U489	156-0956-02		MICROCIRCUIT, DI: OCTAL BFR W/3STATE OUT	01295	SN74LS244NP3
A5U493	156-0956-02		MICROCIRCUIT, DI: OCTAL BFR W/3STATE OUT	01295	SN74LS244NP3
A5U496	156-1393-01		MICROCIRCUIT, DI: QUAD 2 INPUT NAND BFR, SCRNM	01295	SN74S38
A5VR345	152-0195-00		SEMICONV DEVICE: ZENER, 0.4W, 5.1V, 5%	04713	SZ11755

REPLACEABLE ELECTRICAL PARTS

A5 RAM ROM (CONT)

Component No.	Tektronix Part No.	Serial/Model No. Eff Dscont	Name & Description	Mfr Code	Mfr Part Number
A5W129	131-0608-00 -----		TERMINAL,PIN:0.365 L X 0.025 PH BRZ GOLD (QUANTITY OF 3)	22526	47357
A5W130	131-0608-00 -----		TERMINAL,PIN:0.365 L X 0.025 PH BRZ GOLD (QUANTITY OF 2)	22526	47357
A5W131	131-0608-00 -----		TERMINAL,PIN:0.365 L X 0.025 PH BRZ GOLD (QUANTITY OF 2)	22526	47357
A5W132	131-0608-00 -----		TERMINAL,PIN:0.365 L X 0.025 PH BRZ GOLD (QUANTITY OF 2)	22526	47357
A5Y380	158-0081-00 -----		XTAL UNIT,QTZ:22.008MHZ,+/-0.01% (XTAL UNIT REQUIRES FOAM ADHESIVE)	33096	PB3086

REPLACEABLE ELECTRICAL PARTS

Component No.	Tektronix Part No.	Serial/Model No. Eff Dscnt	Name & Description	Mfr Code	Mfr Part Number
A6 RAM ARRAY					
A6	670-6670-00		CKT BOARD ASSY:RAM ARRAY	80009	670-6670-00
A6C11	283-0423-00		CAP.,FXD,CER DI:0.22UF,+80-20%,50V	04222	DG015E224Z
A6C21	283-0423-00		CAP.,FXD,CER DI:0.22UF,+80-20%,50V	04222	DG015E224Z
A6C31	283-0423-00		CAP.,FXD,CER DI:0.22UF,+80-20%,50V	04222	DG015E224Z
A6C41	283-0423-00		CAP.,FXD,CER DI:0.22UF,+80-20%,50V	04222	DG015E224Z
A6C151	290-0748-00		CAP.,FXD,ELCTLT:10UF,+50-10%,20V	56289	500D149
A6C211	283-0423-00		CAP.,FXD,CER DI:0.22UF,+80-20%,50V	04222	DG015E224Z
A6C215	283-0423-00		CAP.,FXD,CER DI:0.22UF,+80-20%,50V	04222	DG015E224Z
A6C221	283-0423-00		CAP.,FXD,CER DI:0.22UF,+80-20%,50V	04222	DG015E224Z
A6C225	283-0423-00		CAP.,FXD,CER DI:0.22UF,+80-20%,50V	04222	DG015E224Z
A6C231	283-0423-00		CAP.,FXD,CER DI:0.22UF,+80-20%,50V	04222	DG015E224Z
A6C235	283-0423-00		CAP.,FXD,CER DI:0.22UF,+80-20%,50V	04222	DG015E224Z
A6C241	283-0423-00		CAP.,FXD,CER DI:0.22UF,+80-20%,50V	04222	DG015E224Z
A6C245	283-0423-00		CAP.,FXD,CER DI:0.22UF,+80-20%,50V	04222	DG015E224Z
A6C351	290-0748-00		CAP.,FXD,ELCTLT:10UF,+50-10%,20V	56289	500D149
A6C411	283-0423-00		CAP.,FXD,CER DI:0.22UF,+80-20%,50V	04222	DG015E224Z
A6C415	283-0423-00		CAP.,FXD,CER DI:0.22UF,+80-20%,50V	04222	DG015E224Z
A6C421	283-0423-00		CAP.,FXD,CER DI:0.22UF,+80-20%,50V	04222	DG015E224Z
A6C425	283-0423-00		CAP.,FXD,CER DI:0.22UF,+80-20%,50V	04222	DG015E224Z
A6C431	283-0423-00		CAP.,FXD,CER DI:0.22UF,+80-20%,50V	04222	DG015E224Z
A6C435	283-0423-00		CAP.,FXD,CER DI:0.22UF,+80-20%,50V	04222	DG015E224Z
A6C441	283-0423-00		CAP.,FXD,CER DI:0.22UF,+80-20%,50V	04222	DG015E224Z
A6C445	283-0423-00		CAP.,FXD,CER DI:0.22UF,+80-20%,50V	04222	DG015E224Z
A6R15	131-0566-00		BUS CONDUCTOR:DUMMY RES,2.375,22 AWG	55210	L-2007-1
A6R25	131-0566-00		BUS CONDUCTOR:DUMMY RES,2.375,22 AWG	55210	L-2007-1
A6R45	131-0566-00		BUS CONDUCTOR:DUMMY RES,2.375,22 AWG	55210	L-2007-1
A6U111	156-0968-02		MICROCIRCUIT,DI:16384 X 1 DYNAMIC RAM	80009	156-0968-02
A6U115	156-0968-02		MICROCIRCUIT,DI:16384 X 1 DYNAMIC RAM	80009	156-0968-02
A6U121	156-0968-02		MICROCIRCUIT,DI:16384 X 1 DYNAMIC RAM	80009	156-0968-02
A6U125	156-0968-02		MICROCIRCUIT,DI:16384 X 1 DYNAMIC RAM	80009	156-0968-02
A6U131	156-0968-02		MICROCIRCUIT,DI:16384 X 1 DYNAMIC RAM	80009	156-0968-02
A6U135	156-0968-02		MICROCIRCUIT,DI:16384 X 1 DYNAMIC RAM	80009	156-0968-02
A6U141	156-0968-02		MICROCIRCUIT,DI:16384 X 1 DYNAMIC RAM	80009	156-0968-02
A6U145	156-0968-02		MICROCIRCUIT,DI:16384 X 1 DYNAMIC RAM	80009	156-0968-02
A6U311	156-0968-02		MICROCIRCUIT,DI:16384 X 1 DYNAMIC RAM	80009	156-0968-02
A6U315	156-0968-02		MICROCIRCUIT,DI:16384 X 1 DYNAMIC RAM	80009	156-0968-02
A6U321	156-0968-02		MICROCIRCUIT,DI:16384 X 1 DYNAMIC RAM	80009	156-0968-02
A6U325	156-0968-02		MICROCIRCUIT,DI:16384 X 1 DYNAMIC RAM	80009	156-0968-02
A6U331	156-0968-02		MICROCIRCUIT,DI:16384 X 1 DYNAMIC RAM	80009	156-0968-02
A6U335	156-0968-02		MICROCIRCUIT,DI:16384 X 1 DYNAMIC RAM	80009	156-0968-02
A6U341	156-0968-02		MICROCIRCUIT,DI:16384 X 1 DYNAMIC RAM	80009	156-0968-02
A6U345	156-0968-02		MICROCIRCUIT,DI:16384 X 1 DYNAMIC RAM	80009	156-0968-02
A6W1	131-0608-00		TERMINAL,PIN:0.365 L X 0.025 PH BRZ GOLD (QUANTITY OF 2)	22526	47357
A6W2	131-0608-00		TERMINAL,PIN:0.365 L X 0.025 PH BRZ GOLD (QUANTITY OF 2)	22526	47357

REPLACEABLE ELECTRICAL PARTS

Component No.	Tektronix Part No.	Serial/Model No. Eff Dscont	Name & Description	Mfr Code	Mfr Part Number
A7 RAM CONTROLLER					
A7	670-6669-00 -----	B010100 B010169	CKT BOARD ASSY:RAM CONTROLLER (OPTION 24 THRU 29 ONLY)	80009	670-6669-00
A7	670-6669-01 -----	B010170 B010429	CKT BOARD ASSY:RAM CONTROLLER (OPTION 24 THRU 29 ONLY)	80009	670-6669-01
A7	670-6669-02 -----	B010430	CKT BOARD ASSY:RAM CONTROLLER (OPTION 24 THRU 29 ONLY)	80009	670-6669-02
A7C151	283-0421-00		CAP.,FXD,CER DI:0.1UF,+80-20%,50V	04222	DG015E104Z
A7C256	281-0797-00		CAP.,FXD,CER DI:15PF,10%,100V	72982	8035D9AADCOG150K
A7C351	283-0421-00		CAP.,FXD,CER DI:0.1UF,+80-20%,50V	04222	DG015E104Z
A7C451	283-0421-00		CAP.,FXD,CER DI:0.1UF,+80-20%,50V	04222	DG015E104Z
A7C515	283-0421-00		CAP.,FXD,CER DI:0.1UF,+80-20%,50V	04222	DG015E104Z
A7C521	283-0421-00		CAP.,FXD,CER DI:0.1UF,+80-20%,50V	04222	DG015E104Z
A7C525	283-0421-00		CAP.,FXD,CER DI:0.1UF,+80-20%,50V	04222	DG015E104Z
A7C531	283-0421-00		CAP.,FXD,CER DI:0.1UF,+80-20%,50V	04222	DG015E104Z
A7C535	283-0421-00		CAP.,FXD,CER DI:0.1UF,+80-20%,50V	04222	DG015E104Z
A7C545	290-0745-00		CAP.,FXD,ELCTLT:22UF,+50-10%,25V	56289	502D225
A7C561	283-0421-00		CAP.,FXD,CER DI:0.1UF,+80-20%,50V	04222	DG015E104Z
A7C565	283-0421-00		CAP.,FXD,CER DI:0.1UF,+80-20%,50V	04222	DG015E104Z
A7C571	283-0421-00		CAP.,FXD,CER DI:0.1UF,+80-20%,50V	04222	DG015E104Z
A7C575	283-0421-00		CAP.,FXD,CER DI:0.1UF,+80-20%,50V	04222	DG015E104Z
A7C581	283-0421-00		CAP.,FXD,CER DI:0.1UF,+80-20%,50V	04222	DG015E104Z
A7C585	283-0421-00		CAP.,FXD,CER DI:0.1UF,+80-20%,50V	04222	DG015E104Z
A7C591	283-0421-00		CAP.,FXD,CER DI:0.1UF,+80-20%,50V	04222	DG015E104Z
A7C595	283-0421-00		CAP.,FXD,CER DI:0.1UF,+80-20%,50V	04222	DG015E104Z
A7CR596	152-0066-00		SEMICONV DEVICE:SILICON,400V,750MA	14433	LG4016
A7J165	131-0608-00 -----		TERMINAL,PIN:0.365 L X 0.025 PH BRZ GOLD (QUANTITY OF 12)	22526	47357
A7J166	131-0608-00 -----		TERMINAL,PIN:0.365 L X 0.025 PH BRZ GOLD (QUANTITY OF 3)	22526	47357
A7L261	108-0088-00		COIL,RF:FIXED,3.35UH	80009	108-0088-00
A7R348	315-0821-00		RES.,FXD,CMPSN:820 OHM,5%,0.25W	01121	CB8215
A7R349	315-0102-00		RES.,FXD,CMPSN:1K OHM,5%,0.25W	01121	CB1025
A7R357	315-0102-00		RES.,FXD,CMPSN:1K OHM,5%,0.25W	01121	CB1025
A7R358	315-0821-00		RES.,FXD,CMPSN:820 OHM,5%,0.25W	01121	CB8215
A7R516	315-0102-00		RES.,FXD,CMPSN:1K OHM,5%,0.25W	01121	CB1025
A7R522	315-0102-00		RES.,FXD,CMPSN:1K OHM,5%,0.25W	01121	CB1025
A7R523	315-0102-00		RES.,FXD,CMPSN:1K OHM,5%,0.25W	01121	CB1025
A7R524	315-0102-00		RES.,FXD,CMPSN:1K OHM,5%,0.25W	01121	CB1025
A7R526	315-0102-00		RES.,FXD,CMPSN:1K OHM,5%,0.25W	01121	CB1025
A7R527	315-0102-00		RES.,FXD,CMPSN:1K OHM,5%,0.25W	01121	CB1025
A7R532	315-0201-00		RES.,FXD,CMPSN:200 OHM,5%,0.25W	01121	CB2015
A7R533	315-0201-00		RES.,FXD,CMPSN:200 OHM,5%,0.25W	01121	CB2015
A7R536	315-0201-00		RES.,FXD,CMPSN:200 OHM,5%,0.25W	01121	CB2015
A7R537	315-0102-00		RES.,FXD,CMPSN:1K OHM,5%,0.25W	01121	CB1025
A7R538	131-0566-00	XB010430	BUS CONDUCTOR:DUMMY RES,2.375,22 AWG	55210	L-2007-1
A7R539	131-0566-00	XB010430	BUS CONDUCTOR:DUMMY RES,2.375,22 AWG	55210	L-2007-1
A7R551	315-0470-00		RES.,FXD,CMPSN:47 OHM,5%,0.25W	01121	CB4705
A7R552	315-0102-00		RES.,FXD,CMPSN:1K OHM,5%,0.25W	01121	CB1025
A7R553	315-0470-00		RES.,FXD,CMPSN:47 OHM,5%,0.25W	01121	CB4705
A7R598	315-0132-00		RES.,FXD,CMPSN:1.3K OHM,5%,0.25W	01121	CB1325
A7U151	156-0694-02		MICROCIRCUIT,DI:DCDR/3 LINE TO 8 LINE,SCRN	07263	74S138DCQR
A7U351	156-0180-04		MICROCIRCUIT,DI:QUAD 2-INPUT NAND GATE	01295	SN74S00NP3
A7U451	156-1442-00	B010100 B010429	MICROCIRCUIT,DI:DYNAMIC RAM CONT,SCRN	18324	D8202
A7U451	156-1599-00	B010430	MICROCIRCUIT,DI:STTL,DYNAMIC RAM CONTROL	34649	D8202A
A7U515	156-0693-02		MICROCIRCUIT,DI:DECODER/DEMULTIPLEXER	27014	DM74S139

REPLACEABLE ELECTRICAL PARTS

A7 RAM CONTROLLER (CONT)

Component No.	Tektronix Part No.	Serial/Model No. Eff Dscnt	Name & Description	Mfr Code	Mfr Part Number
A7U521	156-0459-02		MICROCIRCUIT,DI:QUAD 2 INPUT & GATE,BURN	01295	SN74S08
A7U525	156-0739-02		MICROCIRCUIT,DI:QUAD 2 INP ORGATE,SCRN	01295	SN74S32
A7U531	156-1393-01		MICROCIRCUIT,DI:QUAD 2 INPUT NAND BFR,SCRN	01295	SN74S38
A7U535	156-0331-03	B010100 B010430X	MICROCIRCUIT,DI:DUAL D TYPE POS EDGE TRIG	80009	156-0331-03
A7U536	156-0323-02	XB010170 B010430X	MICROCIRCUIT,DI:HEX INVERTER,BURN-IN	01295	SN74S04
A7U561	156-0739-02		MICROCIRCUIT,DI:QUAD 2 INP ORGATE,SCRN	01295	SN74S32
A7U565	156-0956-02		MICROCIRCUIT,DI:OCTAL BFR W/3STATE OUT	01295	SN74LS244NP3
A7U571	156-1065-01		MICROCIRCUIT,DI:OCTAL D TYPE TRANS LATCHES	34335	AM74LS373
A7U575	156-0956-02		MICROCIRCUIT,DI:OCTAL BFR W/3STATE OUT	01295	SN74LS244NP3
A7U581	156-1065-01		MICROCIRCUIT,DI:OCTAL D TYPE TRANS LATCHES	34335	AM74LS373
A7U585	156-1179-01		MICROCIRCUIT,DI:OCTAL BFR,W/3STATE OUT	01295	SN74S241 JP4
A7U591	156-0956-02		MICROCIRCUIT,DI:OCTAL BFR W/3STATE OUT	01295	SN74LS244NP3
A7U595	156-0956-02		MICROCIRCUIT,DI:OCTAL BFR W/3STATE OUT	01295	SN74LS244NP3
A7VR597	152-0195-00		SEMICONV DEVICE:ZENER,0.4W,5.1V,5%	04713	SZ11755
A7Y251	158-0081-00		XTAL UNIT,QTZ:22.008MHZ,+/-0.01%	33096	PB3086
	-----		(XTAL UNIT REQUIRES FOAM ADHESIVE)		

REPLACEABLE ELECTRICAL PARTS

Component No.	Tektronix Part No.	Serial/Model No. Eff Dscnt	Name & Description	Mfr Code	Mfr Part Number
A8 DISPLAY CONTROLLER					
A8	670-6494-02		CKT BOARD ASSY:DISPLAY CONTROLLER	80009	670-6494-02
A8C1	281-0509-00		CAP.,FXD,CER DI:15PF,+/-1.5PF,500V	59660	301-000C0G0150K
A8C2	283-0421-00		CAP.,FXD,CER DI:0.1UF,+80-20%,50V	04222	DG015E104Z
A8C3	283-0032-00		CAP.,FXD,CER DI:470PF,5%,500V	72982	0831085Z5E00471J
A8C9	281-0509-00		CAP.,FXD,CER DI:15PF,+/-1.5PF,500V	59660	301-000C0G0150K
A8C14	281-0521-00		CAP.,FXD,CER DI:56PF,+/-5.6PF,500V	59660	302-000C0G560K
A8C20	283-0421-00		CAP.,FXD,CER DI:0.1UF,+80-20%,50V	04222	DG015E104Z
A8C40	283-0421-00		CAP.,FXD,CER DI:0.1UF,+80-20%,50V	04222	DG015E104Z
A8C51	283-0067-00		CAP.,FXD,CER DI:0.001UF,10%,200V	59660	835-515-Z5D0102K
A8C63	283-0023-00		CAP.,FXD,CER DI:0.1UF,+80-20%,12V	91418	MX0104Z1205R5
A8C64	283-0212-00		CAP.,FXD,CER DI:2UF,20%,50V	72982	8141N064Z5U205M
A8C100	283-0421-00		CAP.,FXD,CER DI:0.1UF,+80-20%,50V	04222	DG015E104Z
A8C115	283-0421-00		CAP.,FXD,CER DI:0.1UF,+80-20%,50V	04222	DG015E104Z
A8C125	283-0421-00		CAP.,FXD,CER DI:0.1UF,+80-20%,50V	04222	DG015E104Z
A8C140	283-0421-00		CAP.,FXD,CER DI:0.1UF,+80-20%,50V	04222	DG015E104Z
A8C150	283-0421-00		CAP.,FXD,CER DI:0.1UF,+80-20%,50V	04222	DG015E104Z
A8C160	283-0421-00		CAP.,FXD,CER DI:0.1UF,+80-20%,50V	04222	DG015E104Z
A8C210	283-0421-00		CAP.,FXD,CER DI:0.1UF,+80-20%,50V	04222	DG015E104Z
A8C225	283-0421-00		CAP.,FXD,CER DI:0.1UF,+80-20%,50V	04222	DG015E104Z
A8C240	283-0421-00		CAP.,FXD,CER DI:0.1UF,+80-20%,50V	04222	DG015E104Z
A8C255	283-0421-00		CAP.,FXD,CER DI:0.1UF,+80-20%,50V	04222	DG015E104Z
A8C305	283-0421-00		CAP.,FXD,CER DI:0.1UF,+80-20%,50V	04222	DG015E104Z
A8C320	283-0421-00		CAP.,FXD,CER DI:0.1UF,+80-20%,50V	04222	DG015E104Z
A8C330	283-0421-00		CAP.,FXD,CER DI:0.1UF,+80-20%,50V	04222	DG015E104Z
A8C340	283-0421-00		CAP.,FXD,CER DI:0.1UF,+80-20%,50V	04222	DG015E104Z
A8C350	283-0421-00		CAP.,FXD,CER DI:0.1UF,+80-20%,50V	04222	DG015E104Z
A8C360	283-0421-00		CAP.,FXD,CER DI:0.1UF,+80-20%,50V	04222	DG015E104Z
A8C410	283-0421-00		CAP.,FXD,CER DI:0.1UF,+80-20%,50V	04222	DG015E104Z
A8C420	283-0421-00		CAP.,FXD,CER DI:0.1UF,+80-20%,50V	04222	DG015E104Z
A8C430	283-0421-00		CAP.,FXD,CER DI:0.1UF,+80-20%,50V	04222	DG015E104Z
A8C465	283-0421-00		CAP.,FXD,CER DI:0.1UF,+80-20%,50V	04222	DG015E104Z
A8C505	283-0421-00		CAP.,FXD,CER DI:0.1UF,+80-20%,50V	04222	DG015E104Z
A8C515	283-0421-00		CAP.,FXD,CER DI:0.1UF,+80-20%,50V	04222	DG015E104Z
A8C525	283-0032-00		CAP.,FXD,CER DI:470PF,5%,500V	72982	0831085Z5E00471J
A8C530	283-0421-00		CAP.,FXD,CER DI:0.1UF,+80-20%,50V	04222	DG015E104Z
A8C555	283-0421-00		CAP.,FXD,CER DI:0.1UF,+80-20%,50V	04222	DG015E104Z
A8C640	290-0745-00		CAP.,FXD,ELCTLT:22UF,+50-10%,25V	56289	502D225
A8J100	131-0608-00		TERMINAL,PIN:0.365 L X 0.025 PH BRZ GOLD (QUANTITY OF 10)	22526	47357
A8Q51	151-0190-00		TRANSISTOR:SILICON,NPN	07263	S032677
A8Q56	151-0190-00		TRANSISTOR:SILICON,NPN	07263	S032677
A8R1	311-1241-00		RES.,VAR,NONWIR:100K OHM,10%,0.5W	32997	3386X-T07-104
A8R2	315-0473-00		RES.,FXD,CMPSN:47K OHM,5%,0.25W	01121	CB4735
A8R3	315-0163-00		RES.,FXD,CMPSN:16K OHM,5%,0.25W	01121	CB1635
A8R3	311-1241-00		RES.,VAR,NONWIR:100K OHM,10%,0.5W	32997	3386X-T07-104
A8R4	315-0102-00		RES.,FXD,CMPSN:1K OHM,5%,0.25W	01121	CB1025
A8R5	315-0163-00		RES.,FXD,CMPSN:16K OHM,5%,0.25W	01121	CB1635
A8R6	131-0566-00		BUS CONDUCTOR:DUMMY RES,2.375,22 AWG	55210	L-2007-1
A8R7	131-0566-00		BUS CONDUCTOR:DUMMY RES,2.375,22 AWG	55210	L-2007-1
A8R9	315-0204-00		RES.,FXD,CMPSN:200K OHM,5%,0.25W	01121	CB2045
A8R12	131-0566-00		BUS CONDUCTOR:DUMMY RES,2.375,22 AWG	55210	L-2007-1
A8R13	131-0566-00		BUS CONDUCTOR:DUMMY RES,2.375,22 AWG	55210	L-2007-1
A8R14	315-0163-00		RES.,FXD,CMPSN:16K OHM,5%,0.25W	01121	CB1635
A8R15	315-0242-00		RES.,FXD,CMPSN:2.4K OHM,5%,0.25W	01121	CB2425
A8R39	315-0305-00		RES.,FXD,CMPSN:3M OHM,5%,0.25W	01121	CB3055

REPLACEABLE ELECTRICAL PARTS

A8 DISPLAY CONTROLLER (CONT)

Component No.	Tektronix Part No.	Serial/Model No. Eff Dscont	Name & Description	Mfr Code	Mfr Part Number
A8R50	315-0102-00		RES.,FXD,CMPSN:1K OHM,5%,0.25W	01121	CB1025
A8R51	315-0153-00		RES.,FXD,CMPSN:15K OHM,5%,0.25W	01121	CB1535
A8R52	315-0103-00		RES.,FXD,CMPSN:10K OHM,5%,0.25W	01121	CB1035
A8R53	315-0472-00		RES.,FXD,CMPSN:4.7K OHM,5%,0.25W	01121	CB4725
A8R57	315-0302-00		RES.,FXD,CMPSN:3K OHM,5%,0.25W	01121	CB3025
A8R58	315-0102-00		RES.,FXD,CMPSN:1K OHM,5%,0.25W	01121	CB1025
A8R60	131-0566-00		BUS CONDUCTOR:DUMMY RES,2.375,22 AWG	55210	L-2007-1
A8R105	315-0102-00		RES.,FXD,CMPSN:1K OHM,5%,0.25W	01121	CB1025
A8R220	315-0102-00		RES.,FXD,CMPSN:1K OHM,5%,0.25W	01121	CB1025
A8R455	315-0102-00		RES.,FXD,CMPSN:1K OHM,5%,0.25W	01121	CB1025
A8R500	315-0102-00		RES.,FXD,CMPSN:1K OHM,5%,0.25W	01121	CB1025
A8R515	315-0104-00		RES.,FXD,CMPSN:100K OHM,5%,0.25W	01121	CB1045
A8R520	315-0104-00		RES.,FXD,CMPSN:100K OHM,5%,0.25W	01121	CB1045
A8R540	315-0102-00		RES.,FXD,CMPSN:1K OHM,5%,0.25W	01121	CB1025
A8R559	315-0305-00		RES.,FXD,CMPSN:3M OHM,5%,0.25W	01121	CB3055
A8U5	156-1335-00		MICROCIRCUIT,DI:DUAL RETRIG RESET MONO MV	07263	96LS02
A8U10	156-1335-00		MICROCIRCUIT,DI:DUAL RETRIG RESET MONO MV	07263	96LS02
A8U15	156-0386-02		MICROCIRCUIT,DI:TRIPLE 3-INPUT NAND GATE	01295	SN74LS10
A8U20	156-0462-02		MICROCIRCUIT,DI:HEX INVERTER,SCREENED	01295	SN7414
A8U25	156-0385-02		MICROCIRCUIT,DI:HEX INVERTER	01295	SN74LS04
A8U30	156-0465-02		MICROCIRCUIT,DI:8 INP NAND GATE	01295	SN74LS30NP3
A8U35	156-0469-01		MICROCIRCUIT,DI:3-LINE TO 8-LINE DCDR,CHK	80009	156-0469-01
A8U40	156-0382-02		MICROCIRCUIT,DI:QUAD 2-INP NAND GATE	01295	SN74LS00
A8U45	156-0865-02		MICROCIRCUIT,DI:OCTAL D-TYPE FF W/CLEAR	01295	SN74LS273NP3
A8U50	156-0481-02		MICROCIRCUIT,DI:TRIPLE 3 INP & GATE	27014	DM74LS11NA+
A8U55	156-0382-02		MICROCIRCUIT,DI:QUAD 2-INP NAND GATE	01295	SN74LS00
A8U60	156-0387-02		MICROCIRCUIT,DI:DUAL J-K FF,BURN IN	01295	SN74LS73
A8U62	156-0403-01		MICROCIRCUIT,DI:HEX INVERTER,CHK	80009	156-0403-01
A8U65	156-0382-02		MICROCIRCUIT,DI:QUAD 2-INP NAND GATE	01295	SN74LS00
A8U105	156-0852-02		MICROCIRCUIT,DI:HEX DRVR W/3 STATE INP	80009	156-0852-02
A8U110	156-0382-02		MICROCIRCUIT,DI:QUAD 2-INP NAND GATE	01295	SN74LS00
A8U115	156-0464-02		MICROCIRCUIT,DI:DUAL 4 INP NAND GATE	01295	SN74LS20
A8U120	156-0451-02		MICROCIRCUIT,DI:QUAD 2-INP NOR BFR,SCRN	01295	SN74128
A8U125	156-0875-02		MICROCIRCUIT,DI:DUAL 2-W/2 INP AOI GATES	01295	SN74LS51
A8U130	156-0469-01		MICROCIRCUIT,DI:3-LINE TO 8-LINE DCDR,CHK	80009	156-0469-01
A8U135	156-0385-02		MICROCIRCUIT,DI:HEX INVERTER	01295	SN74LS04
A8U140	156-0480-02		MICROCIRCUIT,DI:QUAD 2 INP & GATE	01295	SN74LS08NP3
A8U145	156-0480-02		MICROCIRCUIT,DI:QUAD 2 INP & GATE	01295	SN74LS08NP3
A8U150	156-0479-02		MICROCIRCUIT,DI:QUAD 2-INP ORGATE	01295	SN74LS32NP3
A8U155	156-0388-03		MICROCIRCUIT,DI:DUAL D FLIP-FLOP	07263	74LS74A
A8U160	156-0387-02		MICROCIRCUIT,DI:DUAL J-K FF,BURN IN	01295	SN74LS73
A8U165	156-1065-01		MICROCIRCUIT,DI:OCTAL D TYPE TRANS LATCHES	34335	AM74LS373
A8U205	156-0385-02		MICROCIRCUIT,DI:HEX INVERTER	01295	SN74LS04
A8U210	156-0479-02		MICROCIRCUIT,DI:QUAD 2-INP ORGATE	01295	SN74LS32NP3
A8U215	156-0388-03		MICROCIRCUIT,DI:DUAL D FLIP-FLOP	07263	74LS74A
A8U220	156-0391-02		MICROCIRCUIT,DI:HEX LATCH W/CLEAR	01295	SN74LS174
A8U225	156-0388-03		MICROCIRCUIT,DI:DUAL D FLIP-FLOP	07263	74LS74A
A8U230	156-0386-02		MICROCIRCUIT,DI:TRIPLE 3-INPUT NAND GATE	01295	SN74LS10
A8U235	156-0865-02		MICROCIRCUIT,DI:OCTAL D-TYPE FF W/CLEAR	01295	SN74LS273NP3
A8U240	156-0388-03		MICROCIRCUIT,DI:DUAL D FLIP-FLOP	07263	74LS74A
A8U245	156-0875-02		MICROCIRCUIT,DI:DUAL 2-W/2 INP AOI GATES	01295	SN74LS51
A8U250	156-1209-01		MICROCIRCUIT,DI:MICROPROGRAM SEQ,SCRN	34335	AM2911ADCB
A8U255	156-0480-02		MICROCIRCUIT,DI:QUAD 2 INP & GATE	01295	SN74LS08NP3
A8U260	156-0385-02		MICROCIRCUIT,DI:HEX INVERTER	01295	SN74LS04
A8U265	156-0390-02		MICROCIRCUIT,DI:DUAL 4/2 LINEDCDR/DEMUX	01295	SN74LS155
A8U305	156-0844-02		MICROCIRCUIT,DI:SYN 4 BIT CNTR,SCRN	01295	SN74LS161A
A8U310	156-0844-02		MICROCIRCUIT,DI:SYN 4 BIT CNTR,SCRN	01295	SN74LS161A

REPLACEABLE ELECTRICAL PARTS

A8 DISPLAY CONTROLLER (CONT)

Component No.	Tektronix Part No.	Serial/Model No. Eff Dscont	Name & Description	Mfr Code	Mfr Part Number
A8U315	156-0480-02		MICROCIRCUIT,DI:QUAD 2 INP & GATE	01295	SN74LS08NP3
A8U320	156-0451-02		MICROCIRCUIT,DI:QUAD 2-INP NOR BFR,SCRN	01295	SN74128
A8U325	156-0386-02		MICROCIRCUIT,DI:TRIPLE 3-INPUT NAND GATE	01295	SN74LS10
A8U330	156-0464-02		MICROCIRCUIT,DI:DUAL 4 INP NAND GATE	01295	SN74LS20
A8U335	156-0391-02		MICROCIRCUIT,DI:HEX LATCH W/CLEAR	01295	SN74LS174
A8U340	156-0382-02		MICROCIRCUIT,DI:QUAD 2-INP NAND GATE	01295	SN74LS00
A8U345	156-0530-02		MICROCIRCUIT,DI:QUAD 2-INP MUX,SCRN	01295	SN74LS157P3
A8U350	156-0386-02		MICROCIRCUIT,DI:TRIPLE 3-INPUT NAND GATE	01295	SN74LS10
A8U355	156-1209-01		MICROCIRCUIT,DI:MICROPROGRAM SEQ,SCRN	34335	AM2911ADCB
A8U360	156-0480-02		MICROCIRCUIT,DI:QUAD 2 INP & GATE	01295	SN74LS08NP3
A8U365	156-0385-02		MICROCIRCUIT,DI:HEX INVERTER	01295	SN74LS04
A8U405	156-1172-01		MICROCIRCUIT,DI:DUAL 4 BIT CNTR,BURN IN	01295	SN74LS393
A8U410	156-0530-02		MICROCIRCUIT,DI:QUAD 2-INP MUX,SCRN	01295	SN74LS157P3
A8U415	156-0385-02		MICROCIRCUIT,DI:HEX INVERTER	01295	SN74LS04
A8U420	156-0465-02		MICROCIRCUIT,DI:8 INP NAND GATE	01295	SN74LS30NP3
A8U425	156-0478-02		MICROCIRCUIT,DI:DUAL 4 INP & GATE,BURN-IN	01295	SN74LS21NP3
A8U430	156-0388-03		MICROCIRCUIT,DI:DUAL D FLIP-FLOP	07263	74LS74A
A8U435	156-0530-02		MICROCIRCUIT,DI:QUAD 2-INP MUX,SCRN	01295	SN74LS157P3
A8U440	156-0530-02		MICROCIRCUIT,DI:QUAD 2-INP MUX,SCRN	01295	SN74LS157P3
A8U445	156-0530-02		MICROCIRCUIT,DI:QUAD 2-INP MUX,SCRN	01295	SN74LS157P3
A8U450	156-1209-01		MICROCIRCUIT,DI:MICROPROGRAM SEQ,SCRN	34335	AM2911ADCB
A8U455	156-1209-01		MICROCIRCUIT,DI:MICROPROGRAM SEQ,SCRN	34335	AM2911ADCB
A8U460	156-0735-01		MICROCIRCUIT,DI:4-BIT BISTABLE LATCH,CHK	80009	156-0735-01
A8U465	156-0465-02		MICROCIRCUIT,DI:8 INP NAND GATE	01295	SN74LS30NP3
A8U505	156-0479-02		MICROCIRCUIT,DI:QUAD 2-INP ORGATE	01295	SN74LS32NP3
A8U510	156-0467-02		MICROCIRCUIT,DI:QUAD 2-INP NAND BFR,SCRN	01295	SN74LS38
A8U515	156-0391-02		MICROCIRCUIT,DI:HEX LATCH W/CLEAR	01295	SN74LS174
A8U520	156-0391-02		MICROCIRCUIT,DI:HEX LATCH W/CLEAR	01295	SN74LS174
A8U525	156-1335-00		MICROCIRCUIT,DI:DUAL RETRIG RESET MONO MV	07263	96LS02
A8U530	156-0388-03		MICROCIRCUIT,DI:DUAL D FLIP-FLOP	07263	74LS74A
A8U535	156-0530-02		MICROCIRCUIT,DI:QUAD 2-INP MUX,SCRN	01295	SN74LS157P3
A8U540	156-0865-02		MICROCIRCUIT,DI:OCTAL D-TYPE FF W/CLEAR	01295	SN74LS273NP3
A8U545	156-1209-01		MICROCIRCUIT,DI:MICROPROGRAM SEQ,SCRN	34335	AM2911ADCB
A8U550	156-0388-03		MICROCIRCUIT,DI:DUAL D FLIP-FLOP	07263	74LS74A
A8U555	156-0467-02		MICROCIRCUIT,DI:QUAD 2-INP NAND BFR,SCRN	01295	SN74LS38
A8U560	156-0956-02		MICROCIRCUIT,DI:OCTAL BFR W/3STATE OUT	01295	SN74LS244NP3
A8U565	156-1065-01		MICROCIRCUIT,DI:OCTAL D TYPE TRANS LATCHES	34335	AM74LS373
A8VR49	152-0278-00		SEMICOND DEVICE:ZENER,0.4W,3V,5%	04713	SZG35009K20

REPLACEABLE ELECTRICAL PARTS

Component No.	Tektronix Part No.	Serial/Model No. Eff Dscont	Name & Description	Mfr Code	Mfr Part Number
A9 VECTOR GENERATOR					
A9	670-6495-00		CKT BOARD ASSY:VECTOR GENERATOR	80009	670-6495-00
A9C141	283-0421-00		CAP.,FXD,CER DI:0.1UF,+80-20%,50V	04222	DG015E104Z
A9C151	283-0421-00		CAP.,FXD,CER DI:0.1UF,+80-20%,50V	04222	DG015E104Z
A9C161	283-0421-00		CAP.,FXD,CER DI:0.1UF,+80-20%,50V	04222	DG015E104Z
A9C175	283-0421-00		CAP.,FXD,CER DI:0.1UF,+80-20%,50V	04222	DG015E104Z
A9C185	283-0421-00		CAP.,FXD,CER DI:0.1UF,+80-20%,50V	04222	DG015E104Z
A9C201	283-0421-00		CAP.,FXD,CER DI:0.1UF,+80-20%,50V	04222	DG015E104Z
A9C205	283-0421-00		CAP.,FXD,CER DI:0.1UF,+80-20%,50V	04222	DG015E104Z
A9C211	283-0421-00		CAP.,FXD,CER DI:0.1UF,+80-20%,50V	04222	DG015E104Z
A9C215	283-0421-00		CAP.,FXD,CER DI:0.1UF,+80-20%,50V	04222	DG015E104Z
A9C221	283-0421-00		CAP.,FXD,CER DI:0.1UF,+80-20%,50V	04222	DG015E104Z
A9C225	283-0421-00		CAP.,FXD,CER DI:0.1UF,+80-20%,50V	04222	DG015E104Z
A9C245	283-0421-00		CAP.,FXD,CER DI:0.1UF,+80-20%,50V	04222	DG015E104Z
A9C285	283-0421-00		CAP.,FXD,CER DI:0.1UF,+80-20%,50V	04222	DG015E104Z
A9C303	283-0421-00		CAP.,FXD,CER DI:0.1UF,+80-20%,50V	04222	DG015E104Z
A9C312	283-0421-00		CAP.,FXD,CER DI:0.1UF,+80-20%,50V	04222	DG015E104Z
A9C314	283-0421-00		CAP.,FXD,CER DI:0.1UF,+80-20%,50V	04222	DG015E104Z
A9C341	283-0421-00		CAP.,FXD,CER DI:0.1UF,+80-20%,50V	04222	DG015E104Z
A9C355	283-0421-00		CAP.,FXD,CER DI:0.1UF,+80-20%,50V	04222	DG015E104Z
A9C371	283-0421-00		CAP.,FXD,CER DI:0.1UF,+80-20%,50V	04222	DG015E104Z
A9C385	283-0421-00		CAP.,FXD,CER DI:0.1UF,+80-20%,50V	04222	DG015E104Z
A9C401	283-0421-00		CAP.,FXD,CER DI:0.1UF,+80-20%,50V	04222	DG015E104Z
A9C402	281-0797-00		CAP.,FXD,CER DI:15PF,10%,100V	72982	8035D9AADC0G150K
A9C407	283-0421-00		CAP.,FXD,CER DI:0.1UF,+80-20%,50V	04222	DG015E104Z
A9C416	281-0773-00		CAP.,FXD,CER DI:0.01UF,10%,100V	04222	GC70-1C103K
A9C417	281-0797-00		CAP.,FXD,CER DI:15PF,10%,100V	72982	8035D9AADC0G150K
A9C423	283-0421-00		CAP.,FXD,CER DI:0.1UF,+80-20%,50V	04222	DG015E104Z
A9C424	283-0421-00		CAP.,FXD,CER DI:0.1UF,+80-20%,50V	04222	DG015E104Z
A9C425	283-0421-00		CAP.,FXD,CER DI:0.1UF,+80-20%,50V	04222	DG015E104Z
A9C427	283-0421-00		CAP.,FXD,CER DI:0.1UF,+80-20%,50V	04222	DG015E104Z
A9C429	283-0421-00		CAP.,FXD,CER DI:0.1UF,+80-20%,50V	04222	DG015E104Z
A9C471	283-0421-00		CAP.,FXD,CER DI:0.1UF,+80-20%,50V	04222	DG015E104Z
A9C481	283-0421-00		CAP.,FXD,CER DI:0.1UF,+80-20%,50V	04222	DG015E104Z
A9C503	283-0421-00		CAP.,FXD,CER DI:0.1UF,+80-20%,50V	04222	DG015E104Z
A9C504	281-0773-00		CAP.,FXD,CER DI:0.01UF,10%,100V	04222	GC70-1C103K
A9C505	285-1142-00		CAP.,FXD,PLSTC:0.01UF,1%,200VDC	19396	103F02PP580
A9C506	285-1142-00		CAP.,FXD,PLSTC:0.01UF,1%,200VDC	19396	103F02PP580
A9C507	283-0078-00		CAP.,FXD,CER DI:0.001UF,20%,500V	56289	20C114A8
A9C508	283-0078-00		CAP.,FXD,CER DI:0.001UF,20%,500V	56289	20C114A8
A9C545	283-0421-00		CAP.,FXD,CER DI:0.1UF,+80-20%,50V	04222	DG015E104Z
A9C555	283-0421-00		CAP.,FXD,CER DI:0.1UF,+80-20%,50V	04222	DG015E104Z
A9C585	283-0421-00		CAP.,FXD,CER DI:0.1UF,+80-20%,50V	04222	DG015E104Z
A9C607	283-0421-00		CAP.,FXD,CER DI:0.1UF,+80-20%,50V	04222	DG015E104Z
A9C610	283-0421-00		CAP.,FXD,CER DI:0.1UF,+80-20%,50V	04222	DG015E104Z
A9C616	283-0421-00		CAP.,FXD,CER DI:0.1UF,+80-20%,50V	04222	DG015E104Z
A9C622	281-0773-00		CAP.,FXD,CER DI:0.01UF,10%,100V	04222	GC70-1C103K
A9C641	283-0421-00		CAP.,FXD,CER DI:0.1UF,+80-20%,50V	04222	DG015E104Z
A9C651	283-0421-00		CAP.,FXD,CER DI:0.1UF,+80-20%,50V	04222	DG015E104Z
A9C661	283-0421-00		CAP.,FXD,CER DI:0.1UF,+80-20%,50V	04222	DG015E104Z
A9C675	283-0421-00		CAP.,FXD,CER DI:0.1UF,+80-20%,50V	04222	DG015E104Z
A9C685	283-0421-00		CAP.,FXD,CER DI:0.1UF,+80-20%,50V	04222	DG015E104Z
A9C703	283-0421-00		CAP.,FXD,CER DI:0.1UF,+80-20%,50V	04222	DG015E104Z
A9C706	283-0421-00		CAP.,FXD,CER DI:0.1UF,+80-20%,50V	04222	DG015E104Z
A9C707	283-0421-00		CAP.,FXD,CER DI:0.1UF,+80-20%,50V	04222	DG015E104Z
A9C715	290-0747-00		CAP.,FXD,ELCTLT:100UF,+50-10%,25V	56289	500D148

REPLACEABLE ELECTRICAL PARTS

A9 VECTOR GENERATOR (CONT)

Component No.	Tektronix Part No.	Serial/Model No. Eff Dscont	Name & Description	Mfr Code	Mfr Part Number
A9C716	290-0747-00		CAP.,FXD,ELCTLT:100UF,+50-10%,25V	56289	500D148
A9C751	290-0745-00		CAP.,FXD,ELCTLT:22UF,+50-10%,25V	56289	502D225
A9CR301	152-0322-00		SEMICONV DEVICE:SILICON,15V,HOT CARRIER	50434	5082-2672
A9CR302	152-0322-00		SEMICONV DEVICE:SILICON,15V,HOT CARRIER	50434	5082-2672
A9CR503	152-0322-00		SEMICONV DEVICE:SILICON,15V,HOT CARRIER	50434	5082-2672
A9CR504	152-0322-00		SEMICONV DEVICE:SILICON,15V,HOT CARRIER	50434	5082-2672
A9CR505	152-0322-00		SEMICONV DEVICE:SILICON,15V,HOT CARRIER	50434	5082-2672
A9CR506	152-0322-00		SEMICONV DEVICE:SILICON,15V,HOT CARRIER	50434	5082-2672
A9CR525	152-0322-00		SEMICONV DEVICE:SILICON,15V,HOT CARRIER	50434	5082-2672
A9CR526	152-0322-00		SEMICONV DEVICE:SILICON,15V,HOT CARRIER	50434	5082-2672
A9CR527	152-0322-00		SEMICONV DEVICE:SILICON,15V,HOT CARRIER	50434	5082-2672
A9CR528	152-0322-00		SEMICONV DEVICE:SILICON,15V,HOT CARRIER	50434	5082-2672
A9CR605	152-0322-00		SEMICONV DEVICE:SILICON,15V,HOT CARRIER	50434	5082-2672
A9CR620	152-0066-00		SEMICONV DEVICE:SILICON,400V,750MA	14433	LG4016
A9CR621	152-0141-02		SEMICONV DEVICE:SILICON,30V,150MA	01295	1N4152R
A9J360	131-0608-00		TERMINAL,PIN:0.365 L X 0.025 PH BRZ GOLD (QUANTITY OF 10)	22526	47357
A9L745	108-0598-00		COIL,RF:200UH	80009	108-0598-00
A9L785	108-0598-00		COIL,RF:200UH	80009	108-0598-00
A9Q406	151-1103-00		TRANSISTOR:SILICON,FE,N-CHANNEL	18324	SD210EE
A9Q505	151-1103-00		TRANSISTOR:SILICON,FE,N-CHANNEL	18324	SD210EE
A9Q520	151-1103-00		TRANSISTOR:SILICON,FE,N-CHANNEL	18324	SD210EE
A9Q525	151-1103-00		TRANSISTOR:SILICON,FE,N-CHANNEL	18324	SD210EE
A9Q601	151-0190-00		TRANSISTOR:SILICON,NPN	07263	S032677
A9Q626	151-0478-00		TRANSISTOR:SILICON,NPN	04713	SJE410
A9Q741	151-0190-00		TRANSISTOR:SILICON,NPN	07263	S032677
A9R105	315-0102-00		RES.,FXD,CMPSN:1K OHM,5%,0.25W	01121	CB1025
A9R131	315-0102-00		RES.,FXD,CMPSN:1K OHM,5%,0.25W	01121	CB1025
A9R185	131-0566-00		BUS CONDUCTOR:DUMMY RES,2.375,22 AWG	55210	L-2007-1
A9R201	315-0102-00		RES.,FXD,CMPSN:1K OHM,5%,0.25W	01121	CB1025
A9R245	315-0102-00		RES.,FXD,CMPSN:1K OHM,5%,0.25W	01121	CB1025
A9R301	321-0440-00		RES.,FXD,FILM:374K OHM,1%,0.125W	91637	MFF1816G37402F
A9R313	316-0106-00		RES.,FXD,CMPSN:10M OHM,10%,0.25W	01121	CB1061
A9R314	315-0202-00		RES.,FXD,CMPSN:2K OHM,5%,0.25W	01121	CB2025
A9R345	315-0102-00		RES.,FXD,CMPSN:1K OHM,5%,0.25W	01121	CB1025
A9R401	321-0228-00		RES.,FXD,FILM:2.32K OHM,1%,0.125W	91637	MFF1816G23200F
A9R402	315-0274-00		RES.,FXD,CMPSN:270K OHM,5%,0.25W	01121	CB2745
A9R403	315-0223-00		RES.,FXD,CMPSN:22K OHM,5%,0.25W	01121	CB2235
A9R404	307-0594-00		RES NTWK,FXD FI:7,220 OHM,2%,1.0W	91637	CSP08G01221G
A9R405	315-0224-00		RES.,FXD,CMPSN:220K OHM,5%,0.25W	01121	CB2245
A9R406	315-0104-00		RES.,FXD,CMPSN:100K OHM,5%,0.25W	01121	CB1045
A9R407	315-0151-00		RES.,FXD,CMPSN:150 OHM,5%,0.25W	01121	CB1515
A9R416	315-0224-00		RES.,FXD,CMPSN:220K OHM,5%,0.25W	01121	CB2245
A9R417	321-0228-00		RES.,FXD,FILM:2.32K OHM,1%,0.125W	91637	MFF1816G23200F
A9R418	315-0155-00		RES.,FXD,CMPSN:1.5M OHM,5%,0.25W	01121	CB1555
A9R419	315-0104-00		RES.,FXD,CMPSN:100K OHM,5%,0.25W	01121	CB1045
A9R420	307-0594-00		RES NTWK,FXD FI:7,220 OHM,2%,1.0W	91637	CSP08G01221G
A9R424	311-0613-00		RES.,VAR,NONWIR:100K OHM,10%,0.50W	73138	82-27-2
A9R425	311-0613-00		RES.,VAR,NONWIR:100K OHM,10%,0.50W	73138	82-27-2
A9R426	311-0613-00		RES.,VAR,NONWIR:100K OHM,10%,0.50W	73138	82-27-2
A9R427	311-0613-00		RES.,VAR,NONWIR:100K OHM,10%,0.50W	73138	82-27-2
A9R428	315-0202-00		RES.,FXD,CMPSN:2K OHM,5%,0.25W	01121	CB2025
A9R429	316-0106-00		RES.,FXD,CMPSN:10M OHM,10%,0.25W	01121	CB1061
A9R485	315-0102-00		RES.,FXD,CMPSN:1K OHM,5%,0.25W	01121	CB1025
A9R501	315-0471-00		RES.,FXD,CMPSN:470 OHM,5%,0.25W	01121	CB4715
A9R502	315-0332-00		RES.,FXD,CMPSN:3.3K OHM,5%,0.25W	01121	CB3325
A9R503	321-0309-00		RES.,FXD,FILM:16.2K OHM,1%,0.125W	91637	MFF1816G16201F

REPLACEABLE ELECTRICAL PARTS

A9 VECTOR GENERATOR (CONT)

Component No.	Tektronix Part No.	Serial/Model No. Eff Dscont	Name & Description	Mfr Code	Mfr Part Number
A9R504	315-0151-00		RES.,FXD,CMPSN:150 OHM,5%,0.25W	01121	CB1515
A9R505	321-0322-00		RES.,FXD,FILM:22.1K OHM,1%,0.125W	91637	MFF1816G22101F
A9R507	321-0309-00		RES.,FXD,FILM:16.2K OHM,1%,0.125W	91637	MFF1816G16201F
A9R522	315-0151-00		RES.,FXD,CMPSN:150 OHM,5%,0.25W	01121	CB1515
A9R523	321-0322-00		RES.,FXD,FILM:22.1K OHM,1%,0.125W	91637	MFF1816G22101F
A9R524	315-0151-00		RES.,FXD,CMPSN:150 OHM,5%,0.25W	01121	CB1515
A9R529	321-0309-00		RES.,FXD,FILM:16.2K OHM,1%,0.125W	91637	MFF1816G16201F
A9R530	321-0309-00		RES.,FXD,FILM:16.2K OHM,1%,0.125W	91637	MFF1816G16201F
A9R561	315-0102-00		RES.,FXD,CMPSN:1K OHM,5%,0.25W	01121	CB1025
A9R581	131-0566-00		BUS CONDUCTOR:DUMMY RES,2.375,22 AWG	55210	L-2007-1
A9R601	315-0332-00		RES.,FXD,CMPSN:3.3K OHM,5%,0.25W	01121	CB3325
A9R602	315-0472-00		RES.,FXD,CMPSN:4.7K OHM,5%,0.25W	01121	CB4725
A9R603	315-0272-00		RES.,FXD,CMPSN:2.7K OHM,5%,0.25W	01121	CB2725
A9R604	315-0561-00		RES.,FXD,CMPSN:560 OHM,5%,0.25W	01121	CB5615
A9R605	311-0607-00		RES.,VAR,NONWIR:10K OHM,10%,0.50W	73138	82-25-2
A9R606	315-0103-00		RES.,FXD,CMPSN:10K OHM,5%,0.25W	01121	CB1035
A9R607	321-0356-00		RES.,FXD,FILM:49.9K OHM,1%,0.125W	91637	MFF1816G49901F
A9R608	307-0594-00		RES NTWK,FXD FI:7,220 OHM,2%,1.0W	91637	CSP08G01221G
A9R609	315-0122-00		RES.,FXD,CMPSN:1.2K OHM,5%,0.25W	01121	CB1225
A9R612	315-0182-00		RES.,FXD,CMPSN:1.8K OHM,5%,0.25W	01121	CB1825
A9R613	315-0182-00		RES.,FXD,CMPSN:1.8K OHM,5%,0.25W	01121	CB1825
A9R614	315-0122-00		RES.,FXD,CMPSN:1.2K OHM,5%,0.25W	01121	CB1225
A9R615	307-0592-00		RES,NTWK,FXD FI:9,220 OHM,2%,2W	91637	MSP10A01-221G
A9R616	315-0471-00		RES.,FXD,CMPSN:470 OHM,5%,0.25W	01121	CB4715
A9R617	315-0102-00		RES.,FXD,CMPSN:1K OHM,5%,0.25W	01121	CB1025
A9R618	307-0594-00		RES NTWK,FXD FI:7,220 OHM,2%,1.0W	91637	CSP08G01221G
A9R619	315-0102-00		RES.,FXD,CMPSN:1K OHM,5%,0.25W	01121	CB1025
A9R621	307-0103-00		RES.,FXD,CMPSN:2.7 OHM,5%,0.25W	01121	CB27G5
A9R622	315-0471-00		RES.,FXD,CMPSN:470 OHM,5%,0.25W	01121	CB4715
A9R641	315-0102-00		RES.,FXD,CMPSN:1K OHM,5%,0.25W	01121	CB1025
A9R642	315-0222-00		RES.,FXD,CMPSN:2.2K OHM,5%,0.25W	01121	CB2225
A9R700	321-0366-00		RES.,FXD,FILM:63.4K OHM,1%,0.125W	91637	MFF1816G63401F
A9R701	321-0366-00		RES.,FXD,FILM:63.4K OHM,1%,0.125W	91637	MFF1816G63401F
A9R702	321-0316-00		RES.,FXD,FILM:19.1K OHM,1%,0.125W	91637	MFF1816G19101F
A9R703	315-0471-00		RES.,FXD,CMPSN:470 OHM,5%,0.25W	01121	CB4715
A9R704	311-0613-00		RES.,VAR,NONWIR:100K OHM,10%,0.50W	73138	82-27-2
A9R705	315-0471-00		RES.,FXD,CMPSN:470 OHM,5%,0.25W	01121	CB4715
A9R706	315-0154-00		RES.,FXD,CMPSN:150K OHM,5%,0.25W	01121	CB1545
A9R707	315-0103-00		RES.,FXD,CMPSN:10K OHM,5%,0.25W	01121	CB1035
A9R708	315-0472-00		RES.,FXD,CMPSN:4.7K OHM,5%,0.25W	01121	CB4725
A9R710	315-0201-00		RES.,FXD,CMPSN:200 OHM,5%,0.25W	01121	CB2015
A9R735	308-0399-00		RES.,FXD,WW:10 OHM,5%,5W	91637	RS2AK10R00J
A9TP502	131-1436-00		RCPT,COAX CABLE:CKT BD MT,3-PRONG,BRS GOLD	80009	131-1436-00
A9TP525	131-1436-00		RCPT,COAX CABLE:CKT BD MT,3-PRONG,BRS GOLD	80009	131-1436-00
A9TP706	131-1436-00		RCPT,COAX CABLE:CKT BD MT,3-PRONG,BRS GOLD	80009	131-1436-00
A9TP716	131-1436-00		RCPT,COAX CABLE:CKT BD MT,3-PRONG,BRS GOLD	80009	131-1436-00
A9U101	156-0703-02		MICROCIRCUIT,DI:4-2-3-2 INPUT& OR GATE	07263	74S64
A9U105	156-0739-02		MICROCIRCUIT,DI:QUAD 2 INP ORGATE,SCRN	01295	SN74S32
A9U111	156-0703-02		MICROCIRCUIT,DI:4-2-3-2 INPUT& OR GATE	07263	74S64
A9U115	156-0331-03		MICROCIRCUIT,DI:DUAL D TYPE POS EDGE TRIG	80009	156-0331-03
A9U121	156-0479-02		MICROCIRCUIT,DI:QUAD 2-INP ORGATE	01295	SN74LS32NP3
A9U125	156-0323-02		MICROCIRCUIT,DI:HEX INVERTER,BURN-IN	01295	SN74S04
A9U141	156-0385-02		MICROCIRCUIT,DI:HEX INVERTER	01295	SN74LS04
A9U145	156-0388-03		MICROCIRCUIT,DI:DUAL D FLIP-FLOP	07263	74LS74A
A9U151	156-0530-02		MICROCIRCUIT,DI:QUAD 2-INP MUX,SCRN	01295	SN74LS157P3
A9U155	156-0388-03		MICROCIRCUIT,DI:DUAL D FLIP-FLOP	07263	74LS74A
A9U161	156-0376-01		MICROCIRCUIT,DI:4 BIT PRL I/OSR,BURN-IN	01295	SN74LS195A

REPLACEABLE ELECTRICAL PARTS

A9 VECTOR GENERATOR (CONT)

Component No.	Tektronix Part No.	Serial/Model No. Eff Dscont	Name & Description	Mfr Code	Mfr Part Number
A9U165	156-0391-02		MICROCIRCUIT,DI:HEX LATCH W/CLEAR	01295	SN74LS174
A9U171	156-0311-02		MICROCIRCUIT,DI:6 BIT BINARY RATE MULTI	07263	7497(DCOR)
A9U175	156-0311-02		MICROCIRCUIT,DI:6 BIT BINARY RATE MULTI	07263	7497(DCOR)
A9U181	156-0451-02		MICROCIRCUIT,DI:QUAD 2-INP NOR BFR,SCRN	01295	SN74128
A9U185	156-0331-03		MICROCIRCUIT,DI:DUAL D TYPE POS EDGE TRIG	80009	156-0331-03
A9U201	156-0957-01		MICROCIRCUIT,DI:SYN 4 BIT UP/DOWN BINARY	27014	DM74LS169
A9U205	156-0957-01		MICROCIRCUIT,DI:SYN 4 BIT UP/DOWN BINARY	27014	DM74LS169
A9U211	156-0957-01		MICROCIRCUIT,DI:SYN 4 BIT UP/DOWN BINARY	27014	DM74LS169
A9U215	156-0957-01		MICROCIRCUIT,DI:SYN 4 BIT UP/DOWN BINARY	27014	DM74LS169
A9U221	156-0957-01		MICROCIRCUIT,DI:SYN 4 BIT UP/DOWN BINARY	27014	DM74LS169
A9U225	156-0957-01		MICROCIRCUIT,DI:SYN 4 BIT UP/DOWN BINARY	27014	DM74LS169
A9U241	156-0304-02		MICROCIRCUIT,DI:DUAL 4 INP NAND GATE	01295	SN74S20
A9U245	156-0385-02		MICROCIRCUIT,DI:HEX INVERTER	01295	SN74LS04
A9U251	156-0530-02		MICROCIRCUIT,DI:QUAD 2-INP MUX,SCRN	01295	SN74LS157P3
A9U255	156-0376-01		MICROCIRCUIT,DI:4 BIT PRL I/OSR,BURN-IN	01295	SN74LS195A
A9U261	156-0376-01		MICROCIRCUIT,DI:4 BIT PRL I/OSR,BURN-IN	01295	SN74LS195A
A9U271	156-0391-02		MICROCIRCUIT,DI:HEX LATCH W/CLEAR	01295	SN74LS174
A9U275	156-0311-02		MICROCIRCUIT,DI:6 BIT BINARY RATE MULTI	07263	7497(DCOR)
A9U281	160-1035-00		MICROCIRCUIT,DI:512 X 8 PROM,PRGM	80009	160-1035-00
A9U285	156-0479-02		MICROCIRCUIT,DI:QUAD 2-INP ORGATE	01295	SN74LS32NP3
A9U301	156-0381-02		MICROCIRCUIT,DI:QUAD 2-INP EXCL OR GATE	01295	SN74LS86
A9U305	156-0381-02		MICROCIRCUIT,DI:QUAD 2-INP EXCL OR GATE	01295	SN74LS86
A9U311	156-0381-02		MICROCIRCUIT,DI:QUAD 2-INP EXCL OR GATE	01295	SN74LS86
A9U315	156-0381-02		MICROCIRCUIT,DI:QUAD 2-INP EXCL OR GATE	01295	SN74LS86
A9U321	156-0381-02		MICROCIRCUIT,DI:QUAD 2-INP EXCL OR GATE	01295	SN74LS86
A9U325	156-0381-02		MICROCIRCUIT,DI:QUAD 2-INP EXCL OR GATE	01295	SN74LS86
A9U341	156-0382-02		MICROCIRCUIT,DI:QUAD 2-INP NAND GATE	01295	SN74LS00
A9U345	156-0479-02		MICROCIRCUIT,DI:QUAD 2-INP ORGATE	01295	SN74LS32NP3
A9U351	156-0865-02		MICROCIRCUIT,DI:OCTAL D-TYPE FF W/CLEAR	01295	SN74LS273NP3
A9U355	156-0388-03		MICROCIRCUIT,DI:DUAL D FLIP-FLOP	07263	74LS74A
A9U361	156-0376-01		MICROCIRCUIT,DI:4 BIT PRL I/OSR,BURN-IN	01295	SN74LS195A
A9U371	156-0391-02		MICROCIRCUIT,DI:HEX LATCH W/CLEAR	01295	SN74LS174
A9U375	156-0311-02		MICROCIRCUIT,DI:6 BIT BINARY RATE MULTI	07263	7497(DCOR)
A9U381	156-0696-02		MICROCIRCUIT,DI:QUAD CMLM-OUTPUT & NAND	01295	SN74265J4
A9U385	156-0118-03		MICROCIRCUIT,DI:1 DUAL J-K FF,BURN-IN	01295	SN74S112JP3
A9U404	156-0369-03		MICROCIRCUIT,DI:TRIPLE LINE RECEIVER,SCRN	04713	SC22689P216
A9U405	156-1443-00		MICROCIRCUIT,LI:DA CONVERTER,CUR OUTPUT	13919	2D158
A9U420	156-0369-03		MICROCIRCUIT,DI:TRIPLE LINE RECEIVER,SCRN	04713	SC22689P216
A9U421	156-1443-00		MICROCIRCUIT,LI:DA CONVERTER,CUR OUTPUT	13919	2D158
A9U441	156-0479-02		MICROCIRCUIT,DI:QUAD 2-INP ORGATE	01295	SN74LS32NP3
A9U445	156-0382-02		MICROCIRCUIT,DI:QUAD 2-INP NAND GATE	01295	SN74LS00
A9U451	156-0844-02		MICROCIRCUIT,DI:SYN 4 BIT CNTR,SCRN	01295	SN74LS161A
A9U455	156-0376-01		MICROCIRCUIT,DI:4 BIT PRL I/OSR,BURN-IN	01295	SN74LS195A
A9U461	156-0376-01		MICROCIRCUIT,DI:4 BIT PRL I/OSR,BURN-IN	01295	SN74LS195A
A9U471	156-0391-02		MICROCIRCUIT,DI:HEX LATCH W/CLEAR	01295	SN74LS174
A9U475	156-0311-02		MICROCIRCUIT,DI:6 BIT BINARY RATE MULTI	07263	7497(DCOR)
A9U481	156-0391-02		MICROCIRCUIT,DI:HEX LATCH W/CLEAR	01295	SN74LS174
A9U485	156-0387-02		MICROCIRCUIT,DI:DUAL J-K FF,BURN IN	01295	SN74LS73
A9U515	156-1272-00		MICROCIRCUIT,LI:DUAL OPERATIONAL AMPLIFIER	18324	NE5532 FE-IIB
A9U541	156-0392-03		MICROCIRCUIT,DI:QUAD LATCH W/CLEAR	01295	SN74S175NP3
A9U545	156-0382-02		MICROCIRCUIT,DI:QUAD 2-INP NAND GATE	01295	SN74LS00
A9U551	156-0118-03		MICROCIRCUIT,DI:1 DUAL J-K FF,BURN-IN	01295	SN74S112JP3
A9U555	156-0479-02		MICROCIRCUIT,DI:QUAD 2-INP ORGATE	01295	SN74LS32NP3
A9U561	156-0376-01		MICROCIRCUIT,DI:4 BIT PRL I/OSR,BURN-IN	01295	SN74LS195A
A9U571	156-0844-02		MICROCIRCUIT,DI:SYN 4 BIT CNTR,SCRN	01295	SN74LS161A
A9U575	156-0844-02		MICROCIRCUIT,DI:SYN 4 BIT CNTR,SCRN	01295	SN74LS161A
A9U581	156-0320-03		MICROCIRCUIT,DI:TRIPLE 3 INP NAND GATE	01295	SN74S11NP3

REPLACEABLE ELECTRICAL PARTS

A9 VECTOR GENERATOR (CONT)

Component No.	Tektronix Part No.	Serial/Model No. Eff Dscnt	Name & Description	Mfr Code	Mfr Part Number
A9U585	156-0479-02		MICROCIRCUIT,DI:QUAD 2-INP ORGATE	01295	SN74LS32NP3
A9U608	156-0369-03		MICROCIRCUIT,DI:TRIPLE LINE RECEIVER,SCRN	04713	SC22689P216
A9U615	156-0368-03		MICROCIRCUIT,DI:TTL TO ECL QUAD TRANS	80009	156-0368-03
A9U618	156-0369-03		MICROCIRCUIT,DI:TRIPLE LINE RECEIVER,SCRN	04713	SC22689P216
A9U622	156-0067-13		MICROCIRCUIT,LI:OPNL AMPL,SELECTED	01295	UA741CJG4
A9U641	156-0703-02		MICROCIRCUIT,DI:4-2-3-2 INPUT& OR GATE	07263	74S64
A9U645	156-0481-02		MICROCIRCUIT,DI:TRIPLE 3 INP & GATE	27014	DM74LS11NA+
A9U651	156-0464-02		MICROCIRCUIT,DI:DUAL 4 INP NAND GATE	01295	SN74LS20
A9U655	156-0464-02		MICROCIRCUIT,DI:DUAL 4 INP NAND GATE	01295	SN74LS20
A9U661	156-0651-02		MICROCIRCUIT,DI:8 BIT PRL-OUTSER SHF RGTR	01295	SN74LS164
A9U671	156-0844-02		MICROCIRCUIT,DI:SYN 4 BIT CNTR,SCRN	01295	SN74LS161A
A9U675	156-0844-02		MICROCIRCUIT,DI:SYN 4 BIT CNTR,SCRN	01295	SN74LS161A
A9U681	156-0118-03		MICROCIRCUIT,DI:1 DUAL J-K FF,BURN-IN	01295	SN74S112JP3
A9U685	156-0739-02		MICROCIRCUIT,DI:QUAD 2 INP ORGATE,SCRN	01295	SN74S32
A9U704	156-0158-07		MICROCIRCUIT,LI:DUAL OPNL AMPL,SCREENED	01295	MC1458JG4
A9U755	156-0479-02		MICROCIRCUIT,DI:QUAD 2-INP ORGATE	01295	SN74LS32NP3
A9U761	156-0381-02		MICROCIRCUIT,DI:QUAD 2-INP EXCL OR GATE	01295	SN74LS86
A9U765	156-0331-03		MICROCIRCUIT,DI:DUAL D TYPE POS EDGE TRIG	80009	156-0331-03
A9U771	156-0852-02		MICROCIRCUIT,DI:HEX DRVR W/3 STATE INP	80009	156-0852-02
A9Y185	119-1329-00		OSCILLATOR,RF:CRYSTAL CONTROLLED,24MHZ	75378	MX0-50-1

REPLACEABLE ELECTRICAL PARTS

Component No.	Tektronix Part No.	Serial/Model No. Eff Dscont	Name & Description	Mfr Code	Mfr Part Number
A10 LOGIC EXTENDER					
A10	670-5291-XX -----		CKT BOARD ASSY: (NOT AVAILABLE, USE 067-1005-00)		
A10J611	131-1346-00		CONNECTOR, RCPT, :40/80 DOUBLE ROW	05574	000201-5440
A10J612	131-1606-01		CONNECTOR, RCPT, :W/22-44 CONTACTS	80009	131-1606-01
A10TP1-80	214-0579-00 -----		TERM, TEST POINT: BRS CD PL (ALL TEST POINTS ARE THE SAME)	80009	214-0579-00
A11 INTERCONNECT					
A11	670-5163-01		CKT BOARD ASSY: INTERCONNECT	80009	670-5163-01
A11J10	131-0589-00 -----		TERMINAL, PIN: 0.46 L X 0.025 SQ (QUANTITY OF 10)	22526	48283-029
A11J20	131-0589-00 -----		TERMINAL, PIN: 0.46 L X 0.025 SQ (QUANTITY OF 10)	22526	48283-029
A11J80	131-1976-00		TERM. SET, PIN: 15 MALE CONT	27264	09-60-1151
A11J130	131-0589-00 -----		TERMINAL, PIN: 0.46 L X 0.025 SQ (QUANTITY OF 29)	22526	48283-029
A11J230	131-0589-00 -----		TERMINAL, PIN: 0.46 L X 0.025 SQ (QUANTITY OF 25)	22526	48283-029
A11J330	131-0589-00 -----		TERMINAL, PIN: 0.46 L X 0.025 SQ (QUANTITY OF 27)	22526	48283-029
A11J430	131-0589-00 -----		TERMINAL, PIN: 0.46 L X 0.025 SQ (QUANTITY OF 20)	22526	48283-029
A11J530	131-0589-00 -----		TERMINAL, PIN: 0.46 L X 0.025 SQ (QUANTITY OF 27)	22526	48283-029

REPLACEABLE ELECTRICAL PARTS

Component No.	Tektronix Part No.	Serial/Model No. Eff Dscont	Name & Description	Mfr Code	Mfr Part Number
A12 LV POWER SUPPLY					
A12	670-4798-03		CKT BOARD ASSY:L V POWER SUPPLY	80009	670-4798-03
A12C1	290-0799-00		CAP.,FXD,ELCTLT:300UF,+100-75%,300V	56289	OBD
A12C40	290-0002-00		CAP.,FXD,ELCTLT:8UF,+50-10%,450V	09023	BR8-450
A12C42	283-0002-00		CAP.,FXD,CER DI:0.01UF,+80-20%,500V	91418	SM103Z5014R9
A12C48	281-0770-00		CAP.,FXD,CER DI:0.001UF,20%,100V	72982	8035D9AADX5R102M
A12C55	290-0718-00		CAP.,FXD,ELCTLT:22UF,20%,35V	56289	196D226X0035PE4
A12C61	281-0772-00		CAP.,FXD,CER DI:0.0047UF,10%,100V	04222	GC701C472K
A12C101	290-0799-00		CAP.,FXD,ELCTLT:300UF,+100-75%,300V	56289	OBD
A12C111	290-0581-00		CAP.,FXD,ELCTLT:14,000UF,+75-10%,25V	56289	68D10489
A12C141	290-0746-00		CAP.,FXD,ELCTLT:47UF,+50-10%,16V	55680	16U-47V-T
A12C145	290-0746-00		CAP.,FXD,ELCTLT:47UF,+50-10%,16V	55680	16U-47V-T
A12C148	290-0746-00		CAP.,FXD,ELCTLT:47UF,+50-10%,16V	55680	16U-47V-T
A12C163	281-0523-00		CAP.,FXD,CER DI:100PF,+/-20PF,500V	72982	301-000U2M0101M
A12C168	283-0002-00		CAP.,FXD,CER DI:0.01UF,+80-20%,500V	91418	SM103Z5014R9
A12C201	290-0799-00		CAP.,FXD,ELCTLT:300UF,+100-75%,300V	56289	OBD
A12C211	290-0581-00		CAP.,FXD,ELCTLT:14,000UF,+75-10%,25V	56289	68D10489
A12C221	290-0508-00		CAP.,FXD,ELCTLT:18,000UF,+100-10%,15V	56289	68D10444
A12C231	290-0508-00		CAP.,FXD,ELCTLT:18,000UF,+100-10%,15V	56289	68D10444
A12CR1	152-0066-00		SEMICONV DEVICE:SILICON,400V,750MA	14433	LG4016
A12CR2	152-0066-00		SEMICONV DEVICE:SILICON,400V,750MA	14433	LG4016
A12CR10	152-0666-00		SEMICONV DEVICE:RECT,SI,800V,1.5A	80009	152-0666-00
A12CR56	152-0066-00		SEMICONV DEVICE:SILICON,400V,750MA	14433	LG4016
A12CR66	152-0066-00		SEMICONV DEVICE:SILICON,400V,750MA	14433	LG4016
A12CR105	152-0066-00		SEMICONV DEVICE:SILICON,400V,750MA	14433	LG4016
A12CR127	152-0066-00		SEMICONV DEVICE:SILICON,400V,750MA	14433	LG4016
A12CR141	152-0066-00		SEMICONV DEVICE:SILICON,400V,750MA	14433	LG4016
A12CR143	152-0066-00		SEMICONV DEVICE:SILICON,400V,750MA	14433	LG4016
A12CR145	152-0066-00		SEMICONV DEVICE:SILICON,400V,750MA	14433	LG4016
A12CR163	152-0066-00		SEMICONV DEVICE:SILICON,400V,750MA	14433	LG4016
A12F30	159-0083-00		FUSE,CARTRIDGE:0.15A,250V,FAST-BLOW	71400	AGC 15/100
A12F35	159-0028-00		FUSE,CARTRIDGE:3AG,0.25A,250V,FAST-BLOW	71400	AGC 1/4
A12F137	159-0083-00		FUSE,CARTRIDGE:0.15A,250V,FAST-BLOW	71400	AGC 15/100
A12F139	159-0023-00		FUSE,CARTRIDGE:3AG,2A,250V,5SEC	71400	MDX2
A12F141	159-0023-00		FUSE,CARTRIDGE:3AG,2A,250V,5SEC	71400	MDX2
A12F144	159-0006-00		FUSE,CARTRIDGE:5A,3AG,125V,SLOW-BLOW	71400	MDX5
A12F146	159-0149-00		FUSE,CARTRIDGE:4A,250V,SLOW-BLOW	71400	MDA 4 AMP
A12J32	131-1976-00		TERM. SET,PIN:15 MALE CONT	27264	09-60-1151
A12J43	131-1975-00		TERM. SET,PIN:12 MALE CONTACTS	27264	09-60-1121
A12J134	131-1974-00		TERM. SET,PIN:5 MALE CONTACTS (QUANTITY OF 2)	000CA	09-60-1051
A12Q55	151-0280-00		TRANSISTOR:SILICON,PNP	04713	SS8065
A12Q60	151-0302-00		TRANSISTOR:SILICON,NPN	07263	S038487
A12Q150	151-0190-00		TRANSISTOR:SILICON,NPN	07263	S032677
A12R21	305-0303-00		RES.,FXD,CMPSN:30K OHM,5%,2W	01121	HB3035
A12R23	305-0303-00		RES.,FXD,CMPSN:30K OHM,5%,2W	01121	HB3035
A12R25	305-0303-00		RES.,FXD,CMPSN:30K OHM,5%,2W	01121	HB3035
A12R41	323-0423-00		RES.,FXD,FILM:249K OHM,1%,0.50W	75042	CECT0-2493F
A12R43	321-0724-03		RES.,FXD,FILM:13.6K OHM,0.25W,0.125W	24546	NC55C1362C
A12R45	315-0681-03		RES.,FXD,CMPSN:680 OHM,5%,0.25W	01121	CB6815
A12R47	315-0133-00		RES.,FXD,CMPSN:13K OHM,5%,0.25W	01121	CB1335
A12R50	308-0223-00		RES.,FXD,WW:35 OHM,5%,3W	91637	RS2B-K35R00J
A12R52	315-0471-00		RES.,FXD,CMPSN:470 OHM,5%,0.25W	01121	CB4715
A12R53	315-0202-00		RES.,FXD,CMPSN:2K OHM,5%,0.25W	01121	CB2025
A12R57	315-0471-00		RES.,FXD,CMPSN:470 OHM,5%,0.25W	01121	CB4715
A12R59	315-0302-00		RES.,FXD,CMPSN:3K OHM,5%,0.25W	01121	CB3025

REPLACE

REPLACEABLE ELECTRICAL PARTS

A12 LV POWER SUPPLY (CONT)

Component No.	Tektronix Part No.	Serial/Model No.		Name & Description	Mfr	
		Eff	Dscont		Code	Mfr Part Number
A12R60	315-0101-00			RES., FXD, CMPSN:100 OHM, 5%, 0.25W	01121	CB1015
A12R62	315-0101-00			RES., FXD, CMPSN:100 OHM, 5%, 0.25W	01121	CB1015
A12R64	315-0202-00			RES., FXD, CMPSN:2K OHM, 5%, 0.25W	01121	CB2025
A12R68	315-0101-00			RES., FXD, CMPSN:100 OHM, 5%, 0.25W	01121	CB1015
A12R141	308-0795-00			RES., FXD, WW:0.2 OHM, 5%, 3W	91637	CW-2B .2 OHM 5%
A12R143	308-0795-00			RES., FXD, WW:0.2 OHM, 5%, 3W	91637	CW-2B .2 OHM 5%
A12R145	315-0101-00			RES., FXD, CMPSN:100 OHM, 5%, 0.25W	01121	CB1015
A12R147	315-0472-00			RES., FXD, CMPSN:4.7K OHM, 5%, 0.25W	01121	CB4725
A12R151	315-0471-00			RES., FXD, CMPSN:470 OHM, 5%, 0.25W	01121	CB4715
A12R152	321-0289-03			RES., FXD, FILM:10K OHM, 0.25%, 0.125W	91637	MFF1816D10001C
A12R153	321-0816-07			RES., FXD, FILM:5K OHM, 0.1%, 0.125W	91637	MFF1816C50000B
A12R155	321-0289-03			RES., FXD, FILM:10K OHM, 0.25%, 0.125W	91637	MFF1816D10001C
A12R157	321-0816-07			RES., FXD, FILM:5K OHM, 0.1%, 0.125W	91637	MFF1816C50000B
A12R166	311-1571-00			RES., VAR, NONWIR:500 OHM, 0.50W	73138	91-91-0
A12R167	321-0239-00			RES., FXD, FILM:3.01K OHM, 1%, 0.125W	91637	MFF1816G30100F
A12R169	321-0234-00			RES., FXD, FILM:2.67K OHM, 1%, 0.125W	91637	MFF1816G26700F
A12U51	156-0700-00			MICROCIRCUIT, LI: OPERATIONAL AMPLIFIER	18324	UA741T
A12U61	156-0699-00			MICROCIRCUIT, LI: VOLTAGE REGULATOR	07263	723HM
A12U161	156-0921-00			MICROCIRCUIT, LI: OPERATIONAL AMPLIFIER	02735	CA3140S
A12VR50	152-0669-00			SEMICONV DEVICE: ZENER, SI, 5W, 120V, 5%	80009	152-0669-00
A12VR148	152-0127-00			SEMICONV DEVICE: ZENER, 0.4W, 7.5V, 5%	04713	SZG35009K2

REPLACEABLE ELECTRICAL PARTS

Component No.	Tektronix Part No.	Serial/Model No. Eff Dscnt	Name & Description	Mfr Code	Mfr Part Number
A13 STORAGE					
A13	672-0795-03	B010100 B010169	CKT BOARD ASSY:STORAGE	80009	672-0795-03
A13	672-0795-04	B010170	CKT BOARD ASSY:STORAGE	80009	672-0795-04
A13A1	670-6127-XX		(NOT REPLACEABLE SEE A13)		
A13C09	290-0301-00		CAP.,FXD,ELCLTL:10UF,10%,20V	56289	150D106X9020B2
A13C11	290-0301-00		CAP.,FXD,ELCLTL:10UF,10%,20V	56289	150D106X9020B2
A13C13	290-0301-00		CAP.,FXD,ELCLTL:10UF,10%,20V	56289	150D106X9020B2
A13C15	283-0002-00		CAP.,FXD,CER DI:0.01UF,+80-20%,500V	91418	SM103Z5014R9
A13C18	283-0013-00		CAP.,FXD,CER DI:0.01UF,+100-0%,1000V	56289	33C29A7
A13C37	283-0029-00		CAP.,FXD,CER DI:0.005UF,5%,500V	72982	821-000B502J
A13C67	283-0035-00		CAP.,FXD,CER DI:0.0015UF,20%,400V	72982	811-000Z5U0152Z
A13C78	281-0603-00		CAP.,FXD,CER DI:39PF,5%,500V	59660	308-000C0G0390J
A13C109	281-0773-00		CAP.,FXD,CER DI:0.01UF,10%,100V	04222	GC70-1C103K
A13C110	281-0775-00		CAP.,FXD,CER DI:0.1UF,20%,50V	04222	SA205E104MAA
A13C120	281-0812-00		CAP.,FXD,CER DI:1000PF,10%,100V	72982	8035D9AADX7R102K
A13C121	281-0812-00		CAP.,FXD,CER DI:1000PF,10%,100V	72982	8035D9AADX7R102K
A13C125	281-0775-00		CAP.,FXD,CER DI:0.1UF,20%,50V	04222	SA205E104MAA
A13C126	281-0773-00		CAP.,FXD,CER DI:0.01UF,10%,100V	04222	GC70-1C103K
A13C130	290-0301-00		CAP.,FXD,ELCLTL:10UF,10%,20V	56289	150D106X9020B2
A13C132	281-0812-00		CAP.,FXD,CER DI:1000PF,10%,100V	72982	8035D9AADX7R102K
A13C135	281-0775-00		CAP.,FXD,CER DI:0.1UF,20%,50V	04222	SA205E104MAA
A13C143	290-0297-00		CAP.,FXD,ELCLTL:39UF,10%,10V	56289	150D396X9010B2
A13C153	281-0775-00		CAP.,FXD,CER DI:0.1UF,20%,50V	04222	SA205E104MAA
A13C159	290-0297-00		CAP.,FXD,ELCLTL:39UF,10%,10V	56289	150D396X9010B2
A13C164	281-0775-00		CAP.,FXD,CER DI:0.1UF,20%,50V	04222	SA205E104MAA
A13C165	281-0812-00		CAP.,FXD,CER DI:1000PF,10%,100V	72982	8035D9AADX7R102K
A13C168	290-0297-00		CAP.,FXD,ELCLTL:39UF,10%,10V	56289	150D396X9010B2
A13C171	290-0183-00		CAP.,FXD,ELCLTL:1UF,10%,35V	90201	TAC105K035P02
A13C178	290-0301-00		CAP.,FXD,ELCLTL:10UF,10%,20V	56289	150D106X9020B2
A13C209	290-0288-00		CAP.,FXD,ELCLTL:0.27UF,10%,35V	56289	162D274X9035BC2
A13C214	281-0767-00		CAP.,FXD,CER DI:330PF,20%,100V	12969	CGB331MEX
A13C215	281-0775-00		CAP.,FXD,CER DI:0.1UF,20%,50V	04222	SA205E104MAA
A13C225	281-0775-00		CAP.,FXD,CER DI:0.1UF,20%,50V	04222	SA205E104MAA
A13C226	281-0773-00		CAP.,FXD,CER DI:0.01UF,10%,100V	04222	GC70-1C103K
A13C227	281-0775-00		CAP.,FXD,CER DI:0.1UF,20%,50V	04222	SA205E104MAA
A13C245	281-0812-00		CAP.,FXD,CER DI:1000PF,10%,100V	72982	8035D9AADX7R102K
A13C281	290-0263-00		CAP.,FXD,ELCLTL:2.7UF,15V	56289	162D275X9015CD2
A13C282	290-0183-00		CAP.,FXD,ELCLTL:1UF,10%,35V	90201	TAC105K035P02
A13C288	290-0301-00		CAP.,FXD,ELCLTL:10UF,10%,20V	56289	150D106X9020B2
A13C345	281-0812-00		CAP.,FXD,CER DI:1000PF,10%,100V	72982	8035D9AADX7R102K
A13C346	281-0812-00		CAP.,FXD,CER DI:1000PF,10%,100V	72982	8035D9AADX7R102K
A13C347	281-0812-00		CAP.,FXD,CER DI:1000PF,10%,100V	72982	8035D9AADX7R102K
A13CR32	152-0107-00		SEMICOND DEVICE:SILICON,400V,400MA	01295	G727
A13CR70	152-0333-00		SEMICOND DEVICE:SILICON,55V,200MA	07263	FDH-6012
A13CR80	152-0333-00		SEMICOND DEVICE:SILICON,55V,200MA	07263	FDH-6012
A13CR86	152-0333-00		SEMICOND DEVICE:SILICON,55V,200MA	07263	FDH-6012
A13CR114	152-0333-00		SEMICOND DEVICE:SILICON,55V,200MA	07263	FDH-6012
A13CR124	152-0333-00		SEMICOND DEVICE:SILICON,55V,200MA	07263	FDH-6012
A13CR186	152-0333-00		SEMICOND DEVICE:SILICON,55V,200MA	07263	FDH-6012
A13CR208	152-0333-00		SEMICOND DEVICE:SILICON,55V,200MA	07263	FDH-6012
A13CR221	152-0333-00		SEMICOND DEVICE:SILICON,55V,200MA	07263	FDH-6012
A13CR243	152-0075-00		SEMICOND DEVICE:GE,25V,40MA	14433	G866
A13CR273	152-0333-00		SEMICOND DEVICE:SILICON,55V,200MA	07263	FDH-6012
A13CR278	152-0333-00		SEMICOND DEVICE:SILICON,55V,200MA	07263	FDH-6012
A13CR288	152-0333-00		SEMICOND DEVICE:SILICON,55V,200MA	07263	FDH-6012
A13J3	131-0787-00		CONTACT,ELEC:0.64 INCH LONG (QUANTITY OF 5)	22526	47359

REPLACEABLE ELECTRICAL PARTS

A13 STORAGE (CONT)

Component No.	Tektronix Part No.	Serial/Model No. Eff Dscnt	Name & Description	Mfr Code	Mfr Part Number
A13J4	131-0787-00		CONTACT,ELEC:0.64 INCH LONG (QUANTITY OF 7)	22526	47359
A13Q15	151-0423-00		TRANSISTOR:SILICON,NPN	51984	NTC2333L
A13Q25	151-0423-00		TRANSISTOR:SILICON,NPN	51984	NTC2333L
A13Q28	151-0169-00		TRANSISTOR:SILICON,NPN	04713	ST830
A13Q29	151-0169-00		TRANSISTOR:SILICON,NPN	04713	ST830
A13Q35	151-0423-00		TRANSISTOR:SILICON,NPN	51984	NTC2333L
A13Q36	151-0169-00		TRANSISTOR:SILICON,NPN	04713	ST830
A13Q38	151-0188-00		TRANSISTOR:SILICON,PNP	04713	SPS6868K
A13Q45	151-0423-00		TRANSISTOR:SILICON,NPN	51984	NTC2333L
A13Q55	151-0423-00		TRANSISTOR:SILICON,NPN	51984	NTC2333L
A13Q65	151-0423-00		TRANSISTOR:SILICON,NPN	51984	NTC2333L
A13Q66	151-0169-00		TRANSISTOR:SILICON,NPN	04713	ST830
A13Q68	151-0169-00		TRANSISTOR:SILICON,NPN	04713	ST830
A13Q73	151-0169-00	XB010170	TRANSISTOR:SILICON,NPN	04713	ST830
A13Q75	151-0423-00		TRANSISTOR:SILICON,NPN	51984	NTC2333L
A13Q84	151-0169-00		TRANSISTOR:SILICON,NPN	04713	ST830
A13Q85	151-0423-00		TRANSISTOR:SILICON,NPN	51984	NTC2333L
A13Q86	151-0169-00		TRANSISTOR:SILICON,NPN	04713	ST830
A13Q185	151-0188-00		TRANSISTOR:SILICON,PNP	04713	SPS6868K
A13Q186	151-0188-00		TRANSISTOR:SILICON,PNP	04713	SPS6868K
A13Q190	151-0254-00		TRANSISTOR:SILICON,NPN	03508	X38L3118
A13Q261	151-0188-00		TRANSISTOR:SILICON,PNP	04713	SPS6868K
A13Q264	151-0188-00		TRANSISTOR:SILICON,PNP	04713	SPS6868K
A13Q265	151-0190-00		TRANSISTOR:SILICON,NPN	07263	S032677
A13Q269	151-0188-00		TRANSISTOR:SILICON,PNP	04713	SPS6868K
A13Q270	151-0190-00		TRANSISTOR:SILICON,NPN	07263	S032677
A13Q275	151-0188-00		TRANSISTOR:SILICON,PNP	04713	SPS6868K
A13Q290	151-0254-00		TRANSISTOR:SILICON,NPN	03508	X38L3118
A13Q335	151-0190-00		TRANSISTOR:SILICON,NPN	07263	S032677
A13Q350	151-0190-00		TRANSISTOR:SILICON,NPN	07263	S032677
A13R8	307-0103-00		RES.,FXD,CMPSN:2.7 OHM,5%,0.25W	01121	CB27G5
A13R9	307-0103-00		RES.,FXD,CMPSN:2.7 OHM,5%,0.25W	01121	CB27G5
A13R14	315-0100-02		RES.,FXD,CMPSN:10 OHM,5%,0.25W	01121	CB1005
A13R15	315-0100-02		RES.,FXD,CMPSN:10 OHM,5%,0.25W	01121	CB1005
A13R18	315-0100-02		RES.,FXD,CMPSN:10 OHM,5%,0.25W	01121	CB1005
A13R23	315-0101-00		RES.,FXD,CMPSN:100 OHM,5%,0.25W	01121	CB1015
A13R26	315-0101-00		RES.,FXD,CMPSN:100 OHM,5%,0.25W	01121	CB1015
A13R27	315-0101-00		RES.,FXD,CMPSN:100 OHM,5%,0.25W	01121	CB1015
A13R30	315-0101-00		RES.,FXD,CMPSN:100 OHM,5%,0.25W	01121	CB1015
A13R38	315-0101-00		RES.,FXD,CMPSN:100 OHM,5%,0.25W	01121	CB1015
A13R40	304-0184-00		RES.,FXD,CMPSN:180K OHM,10%,1W	01121	GB1841
A13R43	305-0203-00		RES.,FXD,CMPSN:20K OHM,5%,2W	01121	HB2035
A13R46	305-0203-00		RES.,FXD,CMPSN:20K OHM,5%,2W	01121	HB2035
A13R50	305-0203-00		RES.,FXD,CMPSN:20K OHM,5%,2W	01121	HB2035
A13R53	305-0203-00		RES.,FXD,CMPSN:20K OHM,5%,2W	01121	HB2035
A13R56	323-0459-00		RES.,FXD,FILM:590K OHM,1%,0.50W	91637	MFF1226G59002F
A13R60	315-0100-02		RES.,FXD,CMPSN:10 OHM,5%,0.25W	01121	CB1005
A13R61	315-0102-00		RES.,FXD,CMPSN:1K OHM,5%,0.25W	01121	CB1025
A13R62	315-0100-02		RES.,FXD,CMPSN:10 OHM,5%,0.25W	01121	CB1005
A13R63	315-0512-00		RES.,FXD,CMPSN:5.1K OHM,5%,0.25W	01121	CB5125
A13R64	315-0101-00		RES.,FXD,CMPSN:100 OHM,5%,0.25W	01121	CB1015
A13R70	315-0102-00		RES.,FXD,CMPSN:1K OHM,5%,0.25W	01121	CB1025
A13R72	301-0224-00		RES.,FXD,CMPSN:220K OHM,5%,0.50W	01121	EB2245
A13R73	315-0102-00	XB010170	RES.,FXD,CMPSN:1K OHM,5%,0.25W	01121	CB1025
A13R74	323-0429-00		RES.,FXD,FILM:287K OHM,1%,0.5W	91637	MFF1226G28702F

REPLACEABLE ELECTRICAL PARTS

A13 STORAGE (CONT)

Component No.	Tektronix Part No.	Serial/Model No. Eff Dscnt	Name & Description	Mfr Code	Mfr Part Number
A13R76	323-0429-00		RES.,FXD,FILM:287K OHM,1%,0.5W	91637	MFF1226G28702F
A13R78	301-0224-00		RES.,FXD,CMPSN:220K OHM,5%,0.50W	01121	EB2245
A13R86	315-0102-00		RES.,FXD,CMPSN:1K OHM,5%,0.25W	01121	CB1025
A13R88	315-0103-00		RES.,FXD,CMPSN:10K OHM,5%,0.25W	01121	CB1035
A13R89	315-0101-00		RES.,FXD,CMPSN:100 OHM,5%,0.25W	01121	CB1015
A13R90	305-0823-00		RES.,FXD,CMPSN:82K OHM,5%,2W	01121	HB8235
A13R93	323-0381-00		RES.,FXD,FILM:90.9K OHM,1%,0.50W	75042	CECT0-9092F
A13R95	311-1940-00		RES.,VAR,NONWIR:TRMR,200K OHM,10%	73138	72-206-0
A13R109	315-0472-00		RES.,FXD,CMPSN:4.7K OHM,5%,0.25W	01121	CB4725
A13R110	315-0472-00		RES.,FXD,CMPSN:4.7K OHM,5%,0.25W	01121	CB4725
A13R112	315-0511-00		RES.,FXD,CMPSN:510 OHM,5%,0.25W	01121	CB5115
A13R114	315-0391-00		RES.,FXD,CMPSN:390 OHM,5%,0.25W	01121	CB3915
A13R125	315-0392-00		RES.,FXD,CMPSN:3.9K OHM,5%,0.25W	01121	CB3925
A13R126	315-0512-00		RES.,FXD,CMPSN:5.1K OHM,5%,0.25W	01121	CB5125
A13R127	315-0514-00		RES.,FXD,CMPSN:510K OHM,5%,0.25W	01121	CB5145
A13R129	321-0222-00		RES.,FXD,FILM:2K OHM,1%,0.125W	91637	MFF1816G20000F
A13R132	321-0333-00		RES.,FXD,FILM:28.7K OHM,1%,0.125W	91637	MFF1816G28701F
A13R135	315-0102-00		RES.,FXD,CMPSN:1K OHM,5%,0.25W	01121	CB1025
A13R136	315-0102-00		RES.,FXD,CMPSN:1K OHM,5%,0.25W	01121	CB1025
A13R145	321-0334-00		RES.,FXD,FILM:29.4K OHM,1%,0.125W	91637	MFF1816G29401F
A13R147	315-0472-00		RES.,FXD,CMPSN:4.7K OHM,5%,0.25W	01121	CB4725
A13R154	315-0472-00		RES.,FXD,CMPSN:4.7K OHM,5%,0.25W	01121	CB4725
A13R156	321-0328-00		RES.,FXD,FILM:25.5K OHM,1%,0.125W	91637	MFF1816G25501F
A13R157	315-0101-00		RES.,FXD,CMPSN:100 OHM,5%,0.25W	01121	CB1015
A13R169	321-0334-00		RES.,FXD,FILM:29.4K OHM,1%,0.125W	91637	MFF1816G29401F
A13R174	315-0102-00		RES.,FXD,CMPSN:1K OHM,5%,0.25W	01121	CB1025
A13R175	321-0237-00		RES.,FXD,FILM:2.87K OHM,1%,0.125W	91637	MFF1816G28700F
A13R180	321-0304-00		RES.,FXD,FILM:14.3K OHM,1%,0.125W	91637	MFF1816G14301F
A13R181	315-0101-00		RES.,FXD,CMPSN:100 OHM,5%,0.25W	01121	CB1015
A13R183	315-0101-00		RES.,FXD,CMPSN:100 OHM,5%,0.25W	01121	CB1015
A13R185	315-0103-00		RES.,FXD,CMPSN:10K OHM,5%,0.25W	01121	CB1035
A13R186	315-0105-00		RES.,FXD,CMPSN:1M OHM,5%,0.25W	01121	CB1055
A13R187	321-0311-00		RES.,FXD,FILM:16.9K OHM,1%,0.125W	91637	MFF1816G16901F
A13R188	321-0282-00		RES.,FXD,FILM:8.45K OHM,1%,0.125W	91637	MFF1816G84500F
A13R189	315-0562-00		RES.,FXD,CMPSN:5.6K OHM,5%,0.25W	01121	CB5625
A13R190	321-0282-00		RES.,FXD,FILM:8.45K OHM,1%,0.125W	91637	MFF1816G84500F
A13R191	321-0316-00		RES.,FXD,FILM:19.1K OHM,1%,0.125W	91637	MFF1816G19101F
A13R192	321-0222-00		RES.,FXD,FILM:2K OHM,1%,0.125W	91637	MFF1816G20000F
A13R193	321-0316-00		RES.,FXD,FILM:19.1K OHM,1%,0.125W	91637	MFF1816G19101F
A13R194	321-0316-00	B010100 B010169	RES.,FXD,FILM:19.1K OHM,1%,0.125W	91637	MFF1816G19101F
A13R194	321-0323-00	B010170	RES.,FXD,FILM:22.6K OHM,1%,0.125W	91637	MFF1816G22601F
A13R195	311-1940-00		RES.,VAR,NONWIR:TRMR,200K OHM,10%	73138	72-206-0
A13R197	311-1240-00		RES.,VAR,NONWIR:25K OHM,10%,0.50W	73138	72-30-0
A13R198	311-1940-00		RES.,VAR,NONWIR:TRMR,200K OHM,10%	73138	72-206-0
A13R208	315-0472-00		RES.,FXD,CMPSN:4.7K OHM,5%,0.25W	01121	CB4725
A13R209	315-0510-00		RES.,FXD,CMPSN:51 OHM,5%,0.25W	01121	CB5105
A13R210	315-0103-00		RES.,FXD,CMPSN:10K OHM,5%,0.25W	01121	CB1035
A13R211	315-0472-00		RES.,FXD,CMPSN:4.7K OHM,5%,0.25W	01121	CB4725
A13R212	315-0102-00		RES.,FXD,CMPSN:1K OHM,5%,0.25W	01121	CB1025
A13R220	315-0392-00		RES.,FXD,CMPSN:3.9K OHM,5%,0.25W	01121	CB3925
A13R225	315-0114-00		RES.,FXD,CMPSN:110K OHM,5%,0.25W	01121	CB1145
A13R226	315-0223-00		RES.,FXD,CMPSN:22K OHM,5%,0.25W	01121	CB2235
A13R238	315-0102-00		RES.,FXD,CMPSN:1K OHM,5%,0.25W	01121	CB1025
A13R245	315-0301-00		RES.,FXD,CMPSN:300 OHM,5%,0.25W	01121	CB3015
A13R247	315-0102-00		RES.,FXD,CMPSN:1K OHM,5%,0.25W	01121	CB1025
A13R254	316-0126-00		RES.,FXD,CMPSN:12M OHM,10%,0.25W	01121	CB1261
A13R255	316-0126-00		RES.,FXD,CMPSN:12M OHM,10%,0.25W	01121	CB1261

REPLACEABLE ELECTRICAL PARTS

A13 STORAGE (CONT)

Component No.	Tektronix Part No.	Serial/Model No. Eff Dscont	Name & Description	Mfr Code	Mfr Part Number
A13R256	315-0103-00		RES., FXD, CMPSN: 10K OHM, 5%, 0.25W	01121	CB1035
A13R260	315-0432-00		RES., FXD, CMPSN: 4.3K OHM, 5%, 0.25W	01121	CB4325
A13R261	315-0562-00		RES., FXD, CMPSN: 5.6K OHM, 5%, 0.25W	01121	CB5625
A13R264	315-0432-00		RES., FXD, CMPSN: 4.3K OHM, 5%, 0.25W	01121	CB4325
A13R265	315-0151-00		RES., FXD, CMPSN: 150 OHM, 5%, 0.25W	01121	CB1515
A13R267	315-0511-00		RES., FXD, CMPSN: 510 OHM, 5%, 0.25W	01121	CB5115
A13R270	315-0562-00		RES., FXD, CMPSN: 5.6K OHM, 5%, 0.25W	01121	CB5625
A13R271	315-0102-00		RES., FXD, CMPSN: 1K OHM, 5%, 0.25W	01121	CB1025
A13R272	321-0341-00		RES., FXD, FILM: 34.8K OHM, 1%, 0.125W	91637	MFF1816G34801F
A13R274	315-0432-00		RES., FXD, CMPSN: 4.3K OHM, 5%, 0.25W	01121	CB4325
A13R276	315-0511-00	B010100 B010169	RES., FXD, CMPSN: 510 OHM, 5%, 0.25W	01121	CB5115
A13R276	315-0621-00	B010170	RES., FXD, CMPSN: 620 OHM, 5%, 0.25W	01121	CB6215
A13R279	321-0345-00		RES., FXD, FILM: 38.3K OHM, 1%, 0.125W	91637	MFF1816G38301F
A13R280	315-0562-00		RES., FXD, CMPSN: 5.6K OHM, 5%, 0.25W	01121	CB5625
A13R281	321-0436-00		RES., FXD, FILM: 340K OHM, 1%, 0.125W	91637	MFF1816G34002F
A13R287	321-0390-00		RES., FXD, FILM: 113K OHM, 1%, 0.125W	91637	MFF1816G11302F
A13R288	315-0242-00		RES., FXD, CMPSN: 2.4K OHM, 5%, 0.25W	01121	CB2425
A13R290	315-0105-00		RES., FXD, CMPSN: 1M OHM, 5%, 0.25W	01121	CB1055
A13R291	321-0222-00		RES., FXD, FILM: 2K OHM, 1%, 0.125W	91637	MFF1816G20000F
A13R292	321-0301-00		RES., FXD, FILM: 13.3K OHM, 1%, 0.125W	91637	MFF1816G13301F
A13R295	311-1935-00		RES., VAR, NONWIR: TRMR, 50K OHM, 10%, 0.50W	32997	3299X-R27-503
A13R315	315-0103-00		RES., FXD, CMPSN: 10K OHM, 5%, 0.25W	01121	CB1035
A13R335	315-0103-00		RES., FXD, CMPSN: 10K OHM, 5%, 0.25W	01121	CB1035
A13R336	315-0511-00		RES., FXD, CMPSN: 510 OHM, 5%, 0.25W	01121	CB5115
A13R337	315-0101-00		RES., FXD, CMPSN: 100 OHM, 5%, 0.25W	01121	CB1015
A13R390	308-0777-00	B010100 B010169	RES., FXD, WW: 1 OHM, 5%, 5W	91637	RS5K1R000J
A13R390	308-0165-00	B010170	RES., FXD, WW: 0.5 OHM, 5%, 5W	63743	17951
A13RT389	307-0353-00		RES., VAR, NONWIR: TRMR, 50K OHM, 10%, DISC	15454	5DA5R0-K-270SS
A13TP91	214-0579-00		TERM, TEST POINT: BRS CD PL	80009	214-0579-00
A13TP92	214-0579-00		TERM, TEST POINT: BRS CD PL	80009	214-0579-00
A13TP93	214-0579-00		TERM, TEST POINT: BRS CD PL	80009	214-0579-00
A13TP94	214-0579-00		TERM, TEST POINT: BRS CD PL	80009	214-0579-00
A13U110	156-0371-00		MICROCIRCUIT, DI: QUAD 2-INPUT NAND ST	80009	156-0371-00
A13U115	156-0617-00	B010100 B010169	MICROCIRCUIT, DI: DUAL 4 BIT BIN COUNTER	01295	SN74393N
A13U115	156-0617-02	B010170	MICROCIRCUIT, DI: DUAL 4 BIT CNTR, SCRN	01295	SN74393NP3
A13U125	156-0402-00	B010100 B010169	MICROCIRCUIT, LI: TIMER	27014	LM555CN
A13U125	156-0402-02	B010170	MICROCIRCUIT, LI: TIMER, CHK	27014	LM555CN/A+
A13U136	156-0617-00	B010100 B010169	MICROCIRCUIT, DI: DUAL 4 BIT BIN COUNTER	01295	SN74393N
A13U136	156-0733-02	B010170	MICROCIRCUIT, DI: DUAL MONOSTABLE MV, SCRN	04713	SN74LS221N/J
A13U147	156-0093-00		MICROCIRCUIT, DI: HEX. INVERTER	80009	156-0093-00
A13U154	156-0093-00		MICROCIRCUIT, DI: HEX. INVERTER	80009	156-0093-00
A13U164	156-0617-00	B010100 B010169	MICROCIRCUIT, DI: DUAL 4 BIT BIN COUNTER	01295	SN74393N
A13U164	156-0733-02	B010170	MICROCIRCUIT, DI: DUAL MONOSTABLE MV, SCRN	04713	SN74LS221N/J
A13U175	156-0617-00	B010100 B010169	MICROCIRCUIT, DI: DUAL 4 BIT BIN COUNTER	01295	SN74393N
A13U175	156-0733-02	B010170	MICROCIRCUIT, DI: DUAL MONOSTABLE MV, SCRN	04713	SN74LS221N/J
A13U215	156-0462-00	B010100 B010169	MICROCIRCUIT, DI: HEX SCHMITT TRIG, TTL	80009	156-0462-00
A13U215	156-0462-02	B010170	MICROCIRCUIT, DI: HEX INVERTER, SCREENED	01295	SN7414
A13U225	156-0402-00	B010100 B010169	MICROCIRCUIT, LI: TIMER	27014	LM555CN
A13U225	156-0402-02	B010170	MICROCIRCUIT, LI: TIMER, CHK	27014	LM555CN/A+
A13U235	156-0030-00		MICROCIRCUIT, DI: QUAD 2-INPUT NAND GATE	01295	SN7400(N OR J)
A13U245	156-0371-00		MICROCIRCUIT, DI: QUAD 2-INPUT NAND ST	80009	156-0371-00
A13VR277	152-0279-00		SEMICONV DEVICE: ZENER, 0.4W, 5.1V, 5%	04713	SZG35010RL
A13VR287	152-0279-00		SEMICONV DEVICE: ZENER, 0.4W, 5.1V, 5%	04713	SZG35010RL

REPLACEABLE ELECTRICAL PARTS

Component No.	Tektronix Part No.	Serial/Model No. Eff Dscnt	Name & Description	Mfr Code	Mfr Part Number
A14 HARD COPY AMPLIFIER					
A14	670-3097-01		CKT BOARD ASSY:HARD COPY AMPL	80009	670-3097-01
A14C1	283-0111-00		CAP.,FXD,CER DI:0.1UF,20%,50V	72982	8121-N088Z5U104M
A14C6	283-0111-00		CAP.,FXD,CER DI:0.1UF,20%,50V	72982	8121-N088Z5U104M
A14C12	281-0623-00		CAP.,FXD,CER DI:650PF,5%,500V	04222	7001-1362
A14C13	281-0623-00		CAP.,FXD,CER DI:650PF,5%,500V	04222	7001-1362
A14C17	283-0000-00		CAP.,FXD,CER DI:0.001UF,+100-0%,500V	59660	831-519-Y5P-102P
A14C31	281-0623-00		CAP.,FXD,CER DI:650PF,5%,500V	04222	7001-1362
A14C34	281-0512-00		CAP.,FXD,CER DI:27PF,+/-2.7PF,500V	59660	308-000C0G0270K
A14C35	281-0623-00		CAP.,FXD,CER DI:650PF,5%,500V	04222	7001-1362
A14C105	281-0523-00		CAP.,FXD,CER DI:100PF,+/-20PF,500V	72982	301-000U2M0101M
A14C122	290-0536-00		CAP.,FXD,ELCLTLT:10UF,20%,25V	90201	TDC106M025FL
A14C123	290-0536-00		CAP.,FXD,ELCLTLT:10UF,20%,25V	90201	TDC106M025FL
A14C131	283-0111-00		CAP.,FXD,CER DI:0.1UF,20%,50V	72982	8121-N088Z5U104M
A14C141	283-0008-00		CAP.,FXD,CER DI:0.1UF,20%,500V	56289	2C37X7R104M501B2
A14C142	283-0008-00		CAP.,FXD,CER DI:0.1UF,20%,500V	56289	2C37X7R104M501B2
A14C145	283-0008-00		CAP.,FXD,CER DI:0.1UF,20%,500V	56289	2C37X7R104M501B2
A14C157	283-0111-00		CAP.,FXD,CER DI:0.1UF,20%,50V	72982	8121-N088Z5U104M
A14C158	283-0111-00		CAP.,FXD,CER DI:0.1UF,20%,50V	72982	8121-N088Z5U104M
A14L44	108-0146-00		COIL,RF:5UH	80009	108-0146-00
A14L140	108-0214-00		COIL,RF:400UH	80009	108-0214-00
A14L144	108-0214-00		COIL,RF:400UH	80009	108-0214-00
A14Q115	151-0223-00		TRANSISTOR:SILICON,NPN	04713	SPS8026
A14Q134	151-0134-00		TRANSISTOR:SILICON,PNP	80009	151-0134-00
A14R2	315-0100-00		RES.,FXD,CMPSN:10 OHM,5%,0.25W	01121	CB1005
A14R5	315-0100-00		RES.,FXD,CMPSN:10 OHM,5%,0.25W	01121	CB1005
A14R7	315-0102-00		RES.,FXD,CMPSN:1K OHM,5%,0.25W	01121	CB1025
A14R11	315-0103-00		RES.,FXD,CMPSN:10K OHM,5%,0.25W	01121	CB1035
A14R14	315-0103-00		RES.,FXD,CMPSN:10K OHM,5%,0.25W	01121	CB1035
A14R15	315-0153-00		RES.,FXD,CMPSN:15K OHM,5%,0.25W	01121	CB1535
A14R16	315-0432-00		RES.,FXD,CMPSN:4.3K OHM,5%,0.25W	01121	CB4325
A14R26	311-1228-00		RES.,VAR,NONWIR:10K OHM,20%,0.50W	32997	3386F-T04-103
A14R32	315-0102-00		RES.,FXD,CMPSN:1K OHM,5%,0.25W	01121	CB1025
A14R33	315-0103-00		RES.,FXD,CMPSN:10K OHM,5%,0.25W	01121	CB1035
A14R36	315-0102-00		RES.,FXD,CMPSN:1K OHM,5%,0.25W	01121	CB1025
A14R37	315-0103-00		RES.,FXD,CMPSN:10K OHM,5%,0.25W	01121	CB1035
A14R45	315-0302-00		RES.,FXD,CMPSN:3K OHM,5%,0.25W	01121	CB3025
A14R54	315-0103-00		RES.,FXD,CMPSN:10K OHM,5%,0.25W	01121	CB1035
A14R106	315-0562-00		RES.,FXD,CMPSN:5.6K OHM,5%,0.25W	01121	CB5625
A14R112	315-0472-00		RES.,FXD,CMPSN:4.7K OHM,5%,0.25W	01121	CB4725
A14R113	315-0471-00		RES.,FXD,CMPSN:470 OHM,5%,0.25W	01121	CB4715
A14R114	315-0102-00		RES.,FXD,CMPSN:1K OHM,5%,0.25W	01121	CB1025
A14R121	315-0472-00		RES.,FXD,CMPSN:4.7K OHM,5%,0.25W	01121	CB4725
A14R125	307-0103-00		RES.,FXD,CMPSN:2.7 OHM,5%,0.25W	01121	CB27G5
A14R126	307-0103-00		RES.,FXD,CMPSN:2.7 OHM,5%,0.25W	01121	CB27G5
A14R132	321-0214-00		RES.,FXD,FILM:1.65K OHM,1%,0.125W	91637	MFF1816G16500F
A14R135	301-0151-00		RES.,FXD,CMPSN:150 OHM,5%,0.50W	01121	EB1515
A14R136	321-0231-00		RES.,FXD,FILM:2.49K OHM,1%,0.125W	91637	MFF1816G24900F
A14R145	301-0151-00		RES.,FXD,CMPSN:150 OHM,5%,0.50W	01121	EB1515
A14R146	301-0100-00		RES.,FXD,CMPSN:10 OHM,5%,0.50W	01121	EB1005
A14T53	120-0827-00		XFMR,TOROID:THREE 12 TURN WINDINGS	80009	120-0827-00
A14TP1	214-0579-00		TERM,TEST POINT:BRS CD PL	80009	214-0579-00
A14TP12	214-0579-00		TERM,TEST POINT:BRS CD PL	80009	214-0579-00
A14TP13	214-0579-00		TERM,TEST POINT:BRS CD PL	80009	214-0579-00
A14TP116	214-0579-00		TERM,TEST POINT:BRS CD PL	80009	214-0579-00
A14U3	156-0096-02		MICROCIRCUIT,LI:VOLTAGE COMPARATOR,SCRN	27014	LM311H/A+

REPLACEABLE ELECTRICAL PARTS

A14 HARD COPY AMPLIFIER (CONT)

Component No.	Tektronix Part No.	Serial/Model No. Eff Dscont	Name & Description	Mfr Code	Mfr Part Number
A14U21	156-0162-00		MICROCIRCUIT,LI:DIFFERENTIAL VIDEO AMPL	07263	UA733DC
A14U43	156-0162-00		MICROCIRCUIT,LI:DIFFERENTIAL VIDEO AMPL	07263	UA733DC
A14U101	156-0072-00		MICROCIRCUIT,DI:MONOSTABLE MV,TTL,14 DIP	01295	SN74121(N OR J)

REPLACEABLE ELECTRICAL PARTS

Component No.	Tektronix Part No.	Serial/Model No. Eff Dscont	Name & Description	Mfr Code	Mfr Part Number
A15 DEFLECTION AMPLIFIER					
A15	672-0901-01		CKT BOARD ASSY:DEFLECTION AMPLIFIER	80009	672-0901-01
A15A1	670-7007-XX		(NOT AVAILABLE, SEE A15)		*
A15C15	290-0779-00		CAP.,FXD,ELCTLT:10UF,+50-10%,50VDC	56289	502D237
A15C16	290-0779-00		CAP.,FXD,ELCTLT:10UF,+50-10%,50VDC	56289	502D237
A15C115	290-0745-00		CAP.,FXD,ELCTLT:22UF,+50-10%,25V	56289	502D225
A15C116	290-0745-00		CAP.,FXD,ELCTLT:22UF,+50-10%,25V	56289	502D225
A15C117	290-0745-00		CAP.,FXD,ELCTLT:22UF,+50-10%,25V	56289	502D225
A15C118	290-0745-00		CAP.,FXD,ELCTLT:22UF,+50-10%,25V	56289	502D225
A15C146	281-0812-00		CAP.,FXD,CER DI:1000PF,10%,100V	72982	8035D9AADX7R102K
A15C149	281-0592-00		CAP.,FXD,CER DI:4.7PF,+/-0.5PF,500V	59660	301-000-COH0479D
A15C151	283-0730-00		CAP.,FXD,MICA D:274PF,1%,500V	00853	D155F2740F0
A15C154	283-0594-00		CAP.,FXD,MICA D:0.001UF,1%,100V	00853	D151F102F0
A15C161	283-0730-00		CAP.,FXD,MICA D:274PF,1%,500V	00853	D155F2740F0
A15C164	283-0594-00		CAP.,FXD,MICA D:0.001UF,1%,100V	00853	D151F102F0
A15C176	281-0812-00		CAP.,FXD,CER DI:1000PF,10%,100V	72982	8035D9AADX7R102K
A15C179	281-0592-00		CAP.,FXD,CER DI:4.7PF,+/-0.5PF,500V	59660	301-000-COH0479D
A15C196	283-0060-00		CAP.,FXD,CER DI:100PF,5%,200V	72982	855-535U2J101J
A15C197	283-0060-00		CAP.,FXD,CER DI:100PF,5%,200V	72982	855-535U2J101J
A15C254	290-0745-00		CAP.,FXD,ELCTLT:22UF,+50-10%,25V	56289	502D225
A15C255	290-0745-00		CAP.,FXD,ELCTLT:22UF,+50-10%,25V	56289	502D225
A15C282	281-0826-00		CAP.,FXD,CER DI:2200PF,5%,100V	04222	GA101C222KAA
A15C290	281-0809-00		CAP.,FXD,CER DI:200PF,5%,100V	72982	8013T2ADDC1G201J
A15C292	281-0826-00		CAP.,FXD,CER DI:2200PF,5%,100V	04222	GA101C222KAA
A15C334	281-0788-00		CAP.,FXD,CER DI:470PF,10%,100V	72982	8005H9AADW5R471K
A15C338	281-0788-00		CAP.,FXD,CER DI:470PF,10%,100V	72982	8005H9AADW5R471K
A15C352	285-1069-00		CAP.,FXD,PLSTC:0.047UF,200V	14752	C2319
A15C353	281-0604-00		CAP.,FXD,CER DI:2.2PF,+/-0.25PF,500V	04222	7001-1336
A15C362	285-1069-00		CAP.,FXD,PLSTC:0.047UF,200V	14752	C2319
A15C363	281-0604-00		CAP.,FXD,CER DI:2.2PF,+/-0.25PF,500V	04222	7001-1336
A15C381	281-0775-00		CAP.,FXD,CER DI:0.1UF,20%,50V	04222	SA205E104MAA
A15C393	281-0773-00		CAP.,FXD,CER DI:0.01UF,10%,100V	04222	GC70-1C103K
A15C1001	283-0065-00		CAP.,FXD,CER DI:0.001UF,5%,100V	72982	805-518-Z5D0102J
A15C1101	283-0065-00		CAP.,FXD,CER DI:0.001UF,5%,100V	72982	805-518-Z5D0102J
A15C1102	281-0775-00		CAP.,FXD,CER DI:0.1UF,20%,50V	04222	SA205E104MAA
A15C1106	281-0767-00		CAP.,FXD,CER DI:330PF,20%,100V	12969	CGB331MEX
A15C1202	281-0811-00		CAP.,FXD,CER DI:10PF,10%,100V	72982	8035D2AADC1G100K
A15C1212	281-0775-00		CAP.,FXD,CER DI:0.1UF,20%,50V	04222	SA205E104MAA
A15C1213	281-0772-00		CAP.,FXD,CER DI:0.0047UF,10%,100V	04222	GC701C472K
A15CR21	152-0676-00		SEMICONV DEVICE:RECT,SI,400V,3A	03508	A115DX112
A15CR22	152-0676-00		SEMICONV DEVICE:RECT,SI,400V,3A	03508	A115DX112
A15CR23	152-0676-00		SEMICONV DEVICE:RECT,SI,400V,3A	03508	A115DX112
A15CR24	152-0676-00		SEMICONV DEVICE:RECT,SI,400V,3A	03508	A115DX112
A15CR36	152-0141-02		SEMICONV DEVICE:SILICON,30V,150MA	01295	1N4152R
A15CR42	152-0066-00		SEMICONV DEVICE:SILICON,400V,750MA	14433	LG4016
A15CR43	152-0066-00		SEMICONV DEVICE:SILICON,400V,750MA	14433	LG4016
A15CR44	152-0066-00		SEMICONV DEVICE:SILICON,400V,750MA	14433	LG4016
A15CR45	152-0141-02		SEMICONV DEVICE:SILICON,30V,150MA	01295	1N4152R
A15CR46	152-0141-02		SEMICONV DEVICE:SILICON,30V,150MA	01295	1N4152R
A15CR75	152-0141-02		SEMICONV DEVICE:SILICON,30V,150MA	01295	1N4152R
A15CR76	152-0141-02		SEMICONV DEVICE:SILICON,30V,150MA	01295	1N4152R
A15CR82	152-0066-00		SEMICONV DEVICE:SILICON,400V,750MA	14433	LG4016
A15CR83	152-0066-00		SEMICONV DEVICE:SILICON,400V,750MA	14433	LG4016
A15CR86	152-0141-02		SEMICONV DEVICE:SILICON,30V,150MA	01295	1N4152R
A15CR119	152-0322-00		SEMICONV DEVICE:SILICON,15V,HOT CARRIER	50434	5082-2672
A15CR132	152-0141-02		SEMICONV DEVICE:SILICON,30V,150MA	01295	1N4152R
A15CR137	152-0141-02		SEMICONV DEVICE:SILICON,30V,150MA	01295	1N4152R

REPLACEABLE ELECTRICAL PARTS

A15 DEFLECTION AMPLIFIER (CONT)

Component No.	Tektronix Part No.	Serial/Model No. Eff Dscont	Name & Description	Mfr Code	Mfr Part Number
A15CR139	152-0141-02		SEMICON D DEVICE: SILICON, 30V, 150MA	01295	1N4152R
A15CR142	152-0141-02		SEMICON D DEVICE: SILICON, 30V, 150MA	01295	1N4152R
A15CR172	152-0141-02		SEMICON D DEVICE: SILICON, 30V, 150MA	01295	1N4152R
A15CR182	152-0141-02		SEMICON D DEVICE: SILICON, 30V, 150MA	01295	1N4152R
A15CR187	152-0141-02		SEMICON D DEVICE: SILICON, 30V, 150MA	01295	1N4152R
A15CR189	152-0141-02		SEMICON D DEVICE: SILICON, 30V, 150MA	01295	1N4152R
A15CR283	152-0141-02		SEMICON D DEVICE: SILICON, 30V, 150MA	01295	1N4152R
A15CR284	152-0141-02		SEMICON D DEVICE: SILICON, 30V, 150MA	01295	1N4152R
A15CR285	152-0141-02		SEMICON D DEVICE: SILICON, 30V, 150MA	01295	1N4152R
A15CR286	152-0141-02		SEMICON D DEVICE: SILICON, 30V, 150MA	01295	1N4152R
A15CR372	152-0141-02		SEMICON D DEVICE: SILICON, 30V, 150MA	01295	1N4152R
A15CR373	152-0141-02		SEMICON D DEVICE: SILICON, 30V, 150MA	01295	1N4152R
A15CR382	152-0141-02		SEMICON D DEVICE: SILICON, 30V, 150MA	01295	1N4152R
A15CR383	152-0141-02		SEMICON D DEVICE: SILICON, 30V, 150MA	01295	1N4152R
A15CR423	152-0322-00		SEMICON D DEVICE: SILICON, 15V, HOT CARRIER	50434	5082-2672
A15CR454	152-0141-02		SEMICON D DEVICE: SILICON, 30V, 150MA	01295	1N4152R
A15CR455	152-0141-02		SEMICON D DEVICE: SILICON, 30V, 150MA	01295	1N4152R
A15CR464	152-0141-02		SEMICON D DEVICE: SILICON, 30V, 150MA	01295	1N4152R
A15CR465	152-0141-02		SEMICON D DEVICE: SILICON, 30V, 150MA	01295	1N4152R
A15CR474	152-0141-02		SEMICON D DEVICE: SILICON, 30V, 150MA	01295	1N4152R
A15CR484	152-0141-02		SEMICON D DEVICE: SILICON, 30V, 150MA	01295	1N4152R
A15CR1104	152-0141-02		SEMICON D DEVICE: SILICON, 30V, 150MA	01295	1N4152R
A15CR1313	152-0141-02		SEMICON D DEVICE: SILICON, 30V, 150MA	01295	1N4152R
A15CR1411	152-0141-02		SEMICON D DEVICE: SILICON, 30V, 150MA	01295	1N4152R
A15CR1414	152-0141-02		SEMICON D DEVICE: SILICON, 30V, 150MA	01295	1N4152R
A15J56	131-0589-00		TERMINAL, PIN: 0.46 L X 0.025 SQ (QUANTITY OF 3)	22526	48283-029
A15J66	131-0589-00		TERMINAL, PIN: 0.46 L X 0.025 SQ (QUANTITY OF 3)	22526	48283-029
A15J199	131-0589-00		TERMINAL, PIN: 0.46 L X 0.025 SQ (QUANTITY OF 8)	22526	48283-029
A15J311	131-0589-00		TERMINAL, PIN: 0.46 L X 0.025 SQ (QUANTITY OF 2)	22526	48283-029
A15J314	131-0589-00		TERMINAL, PIN: 0.46 L X 0.025 SQ (QUANTITY OF 2)	22526	48283-029
A15Q20	151-0607-00		TRANSISTOR: SILICON, PNP	04713	SJE376
A15Q26	151-0190-00		TRANSISTOR: SILICON, NPN	07263	S032677
A15Q27	151-0188-00		TRANSISTOR: SILICON, PNP	04713	SPS6868K
A15Q30	151-0606-00		TRANSISTOR: SILICON, NPN	04713	SJE375
A15Q36	151-0188-00		TRANSISTOR: SILICON, PNP	04713	SPS6868K
A15Q38	151-0190-00		TRANSISTOR: SILICON, NPN	07263	S032677
A15Q40	151-0606-00		TRANSISTOR: SILICON, NPN	04713	SJE375
A15Q46	151-0190-00		TRANSISTOR: SILICON, NPN	07263	S032677
A15Q48	151-0188-00		TRANSISTOR: SILICON, PNP	04713	SPS6868K
A15Q50	151-0607-00		TRANSISTOR: SILICON, PNP	04713	SJE376
A15Q60	151-0606-00		TRANSISTOR: SILICON, NPN	04713	SJE375
A15Q70	151-0607-00		TRANSISTOR: SILICON, PNP	04713	SJE376
A15Q75	151-0188-00		TRANSISTOR: SILICON, PNP	04713	SPS6868K
A15Q76	151-0188-00		TRANSISTOR: SILICON, PNP	04713	SPS6868K
A15Q78	151-0190-00		TRANSISTOR: SILICON, NPN	07263	S032677
A15Q80	151-0607-00		TRANSISTOR: SILICON, PNP	04713	SJE376
A15Q84	151-0190-00		TRANSISTOR: SILICON, NPN	07263	S032677
A15Q86	151-0190-00		TRANSISTOR: SILICON, NPN	07263	S032677
A15Q88	151-0188-00		TRANSISTOR: SILICON, PNP	04713	SPS6868K
A15Q90	151-0606-00		TRANSISTOR: SILICON, NPN	04713	SJE375
A15Q96	151-0190-00		TRANSISTOR: SILICON, NPN	07263	S032677
A15Q97	151-0188-00		TRANSISTOR: SILICON, PNP	04713	SPS6868K

REPLACEABLE ELECTRICAL PARTS

A15 DEFLECTION AMPLIFIER (CONT)

Component No.	Tektronix Part No.	Serial/Model No. Eff Dscont	Name & Description	Mfr Code	Mfr Part Number
A15Q239	151-0190-00		TRANSISTOR:SILICON,NPN	07263	S032677
A15Q249	151-0190-00		TRANSISTOR:SILICON,NPN	07263	S032677
A15Q296	151-0190-00		TRANSISTOR:SILICON,NPN	07263	S032677
A15Q411	151-0190-00		TRANSISTOR:SILICON,NPN	07263	S032677
A15Q496	151-0190-00		TRANSISTOR:SILICON,NPN	07263	S032677
A15Q1200	151-0190-00		TRANSISTOR:SILICON,NPN	07263	S032677
A15Q1201	151-0190-00		TRANSISTOR:SILICON,NPN	07263	S032677
A15R17	308-0242-00		RES.,FXD,WW:0.25 OHM,5%,5W	91637	CW2A-ER2500K
A15R25	315-0102-00		RES.,FXD,CMPSN:1K OHM,5%,0.25W	01121	CB1025
A15R26	315-0102-00		RES.,FXD,CMPSN:1K OHM,5%,0.25W	01121	CB1025
A15R28	315-0101-00		RES.,FXD,CMPSN:100 OHM,5%,0.25W	01121	CB1015
A15R34	315-0102-00		RES.,FXD,CMPSN:1K OHM,5%,0.25W	01121	CB1025
A15R35	315-0101-00		RES.,FXD,CMPSN:100 OHM,5%,0.25W	01121	CB1015
A15R42	307-0593-00		RES.,FXD,FOIL:0.25 OHM,5%	80009	307-0593-00
A15R43	308-0590-00		RES.,FXD,WW:0.25 OHM,5%,3W	91637	RS2B-ER2500J
A15R44	315-0102-00		RES.,FXD,CMPSN:1K OHM,5%,0.25W	01121	CB1025
A15R45	315-0101-00		RES.,FXD,CMPSN:100 OHM,5%,0.25W	01121	CB1015
A15R50	311-1244-00		RES.,VAR, NONWIR:100 OHM,10%,0.50W	32997	3386X-T07-101
A15R51	311-1245-00		RES.,VAR, NONWIR:10K OHM,10%,0.50W	73138	72-28-0
A15R52	308-0590-00		RES.,FXD,WW:0.25 OHM,5%,3W	91637	RS2B-ER2500J
A15R54	315-0151-00		RES.,FXD,CMPSN:150 OHM,5%,0.25W	01121	CB1515
A15R55	315-0151-00		RES.,FXD,CMPSN:150 OHM,5%,0.25W	01121	CB1515
A15R57	315-0274-00		RES.,FXD,CMPSN:270K OHM,5%,0.25W	01121	CB2745
A15R58	315-0274-00		RES.,FXD,CMPSN:270K OHM,5%,0.25W	01121	CB2745
A15R60	308-0590-00		RES.,FXD,WW:0.25 OHM,5%,3W	91637	RS2B-ER2500J
A15R64	315-0151-00		RES.,FXD,CMPSN:150 OHM,5%,0.25W	01121	CB1515
A15R65	315-0151-00		RES.,FXD,CMPSN:150 OHM,5%,0.25W	01121	CB1515
A15R66	315-0274-00		RES.,FXD,CMPSN:270K OHM,5%,0.25W	01121	CB2745
A15R67	311-1244-00		RES.,VAR, NONWIR:100 OHM,10%,0.50W	32997	3386X-T07-101
A15R68	315-0274-00		RES.,FXD,CMPSN:270K OHM,5%,0.25W	01121	CB2745
A15R69	311-1245-00		RES.,VAR, NONWIR:10K OHM,10%,0.50W	73138	72-28-0
A15R71	308-0590-00		RES.,FXD,WW:0.25 OHM,5%,3W	91637	RS2B-ER2500J
A15R72	307-0593-00		RES.,FXD,FOIL:0.25 OHM,5%	80009	307-0593-00
A15R74	315-0102-00		RES.,FXD,CMPSN:1K OHM,5%,0.25W	01121	CB1025
A15R75	315-0101-00		RES.,FXD,CMPSN:100 OHM,5%,0.25W	01121	CB1015
A15R84	315-0102-00		RES.,FXD,CMPSN:1K OHM,5%,0.25W	01121	CB1025
A15R85	315-0101-00		RES.,FXD,CMPSN:100 OHM,5%,0.25W	01121	CB1015
A15R95	315-0102-00		RES.,FXD,CMPSN:1K OHM,5%,0.25W	01121	CB1025
A15R96	315-0102-00		RES.,FXD,CMPSN:1K OHM,5%,0.25W	01121	CB1025
A15R98	315-0101-00		RES.,FXD,CMPSN:100 OHM,5%,0.25W	01121	CB1015
A15R99	315-0101-00		RES.,FXD,CMPSN:100 OHM,5%,0.25W	01121	CB1015
A15R119	315-0102-00		RES.,FXD,CMPSN:1K OHM,5%,0.25W	01121	CB1025
A15R121	315-0101-00		RES.,FXD,CMPSN:100 OHM,5%,0.25W	01121	CB1015
A15R122	321-0244-00		RES.,FXD,FILM:3.4K OHM,1%,0.125W	91637	MFF1816G34000F
A15R123	321-0104-00		RES.,FXD,FILM:118 OHM,1%,0.125W	91637	MFF1816G118ROF
A15R124	321-0244-00		RES.,FXD,FILM:3.4K OHM,1%,0.125W	91637	MFF1816G34000F
A15R125	321-0104-00		RES.,FXD,FILM:118 OHM,1%,0.125W	91637	MFF1816G118ROF
A15R131	315-0220-00		RES.,FXD,CMPSN:22 OHM,5%,0.25W	01121	CB2205
A15R133	315-0102-00		RES.,FXD,CMPSN:1K OHM,5%,0.25W	01121	CB1025
A15R134	315-0101-00		RES.,FXD,CMPSN:100 OHM,5%,0.25W	01121	CB1015
A15R135	315-0101-00		RES.,FXD,CMPSN:100 OHM,5%,0.25W	01121	CB1015
A15R139	315-0101-00		RES.,FXD,CMPSN:100 OHM,5%,0.25W	01121	CB1015
A15R141	315-0220-00		RES.,FXD,CMPSN:22 OHM,5%,0.25W	01121	CB2205
A15R143	315-0102-00		RES.,FXD,CMPSN:1K OHM,5%,0.25W	01121	CB1025
A15R144	315-0221-00		RES.,FXD,CMPSN:220 OHM,5%,0.25W	01121	CB2215
A15R145	315-0221-00		RES.,FXD,CMPSN:220 OHM,5%,0.25W	01121	CB2215
A15R147	315-0102-00		RES.,FXD,CMPSN:1K OHM,5%,0.25W	01121	CB1025

REPLACEABLE ELECTRICAL PARTS

A15 DEFLECTION AMPLIFIER (CONT)

Component No.	Tektronix Part No.	Serial/Model No. Eff Dscnt	Name & Description	Mfr Code	Mfr Part Number
A15R148	315-0153-00		RES.,FXD,CMPSN:15K OHM,5%,0.25W	01121	CB1535
A15R149	315-0134-00		RES.,FXD,CMPSN:130K OHM,5%,0.25W	01121	CB1345
A15R150	311-1245-00		RES.,VAR, NONWIR:10K OHM,10%,0.50W	73138	72-28-0
A15R152	321-0127-00		RES.,FXD,FILM:205 OHM,1%,0.125W	91637	MFF1816G205R0F
A15R153	321-0202-00		RES.,FXD,FILM:1.24K OHM,1%,0.125W	91637	MFF1816G12400F
A15R162	321-0127-00		RES.,FXD,FILM:205 OHM,1%,0.125W	91637	MFF1816G205R0F
A15R163	321-0202-00		RES.,FXD,FILM:1.24K OHM,1%,0.125W	91637	MFF1816G12400F
A15R167	311-1245-00		RES.,VAR, NONWIR:10K OHM,10%,0.50W	73138	72-28-0
A15R171	315-0220-00		RES.,FXD,CMPSN:22 OHM,5%,0.25W	01121	CB2205
A15R173	315-0102-00		RES.,FXD,CMPSN:1K OHM,5%,0.25W	01121	CB1025
A15R174	315-0221-00		RES.,FXD,CMPSN:220 OHM,5%,0.25W	01121	CB2215
A15R175	315-0221-00		RES.,FXD,CMPSN:220 OHM,5%,0.25W	01121	CB2215
A15R177	315-0102-00		RES.,FXD,CMPSN:1K OHM,5%,0.25W	01121	CB1025
A15R178	315-0153-00		RES.,FXD,CMPSN:15K OHM,5%,0.25W	01121	CB1535
A15R179	315-0134-00		RES.,FXD,CMPSN:130K OHM,5%,0.25W	01121	CB1345
A15R181	315-0220-00		RES.,FXD,CMPSN:22 OHM,5%,0.25W	01121	CB2205
A15R183	315-0102-00		RES.,FXD,CMPSN:1K OHM,5%,0.25W	01121	CB1025
A15R184	315-0101-00		RES.,FXD,CMPSN:100 OHM,5%,0.25W	01121	CB1015
A15R185	315-0101-00		RES.,FXD,CMPSN:100 OHM,5%,0.25W	01121	CB1015
A15R192	321-0244-00		RES.,FXD,FILM:3.4K OHM,1%,0.125W	91637	MFF1816G34000F
A15R193	321-0104-00		RES.,FXD,FILM:118 OHM,1%,0.125W	91637	MFF1816G118R0F
A15R194	321-0244-00		RES.,FXD,FILM:3.4K OHM,1%,0.125W	91637	MFF1816G34000F
A15R195	321-0104-00		RES.,FXD,FILM:118 OHM,1%,0.125W	91637	MFF1816G118R0F
A15R211	321-0289-00		RES.,FXD,FILM:10K OHM,1%,0.125W	91637	MFF1816G10001F
A15R212	321-0193-00		RES.,FXD,FILM:1K OHM,1%,0.125W	91637	MFF1816G10000F
A15R213	321-0236-00		RES.,FXD,FILM:2.8K OHM,1%,0.125W	91637	MFF1816G28000F
A15R214	321-0277-00		RES.,FXD,FILM:7.5K OHM,1%,0.125W	91637	MFF1816G75000F
A15R215	321-0193-00		RES.,FXD,FILM:1K OHM,1%,0.125W	91637	MFF1816G10000F
A15R216	321-0289-00		RES.,FXD,FILM:10K OHM,1%,0.125W	91637	MFF1816G10001F
A15R217	321-0193-00		RES.,FXD,FILM:1K OHM,1%,0.125W	91637	MFF1816G10000F
A15R218	321-0208-00		RES.,FXD,FILM:1.43K OHM,1%,0.125W	91637	MFF1816G14300F
A15R227	311-1239-00		RES.,VAR, NONWIR:2.5K OHM,10%,0.50W	73138	72-26-0
A15R228	311-1237-00		RES.,VAR, NONWIR:1K OHM,10%,0.50W	32997	3386X-T07-102
A15R229	311-1245-00		RES.,VAR, NONWIR:10K OHM,10%,0.50W	73138	72-28-0
A15R233	315-0101-00		RES.,FXD,CMPSN:100 OHM,5%,0.25W	01121	CB1015
A15R235	321-0330-00		RES.,FXD,FILM:26.7K OHM,1%,0.125W	91637	MFF1816G26701F
A15R237	315-0101-00		RES.,FXD,CMPSN:100 OHM,5%,0.25W	01121	CB1015
A15R238	315-0182-00		RES.,FXD,CMPSN:1.8K OHM,5%,0.25W	01121	CB1825
A15R242	315-0101-00		RES.,FXD,CMPSN:100 OHM,5%,0.25W	01121	CB1015
A15R245	321-0289-00		RES.,FXD,FILM:10K OHM,1%,0.125W	91637	MFF1816G10001F
A15R247	315-0101-00		RES.,FXD,CMPSN:100 OHM,5%,0.25W	01121	CB1015
A15R248	315-0182-00		RES.,FXD,CMPSN:1.8K OHM,5%,0.25W	01121	CB1825
A15R250	311-1241-00		RES.,VAR, NONWIR:100K OHM,10%,0.50W	32997	3386X-T07-104
A15R251	321-0285-00		RES.,FXD,FILM:9.09K OHM,1%,0.125W	91637	MFF1816G90900F
A15R252	315-0104-00		RES.,FXD,CMPSN:100K OHM,5%,0.25W	01121	CB1045
A15R253	321-0202-00		RES.,FXD,FILM:1.24K OHM,1%,0.125W	91637	MFF1816G12400F
A15R261	321-0286-00		RES.,FXD,FILM:9.31K OHM,1%,0.125W	91637	MFF1816G93100F
A15R262	315-0104-00		RES.,FXD,CMPSN:100K OHM,5%,0.25W	01121	CB1045
A15R263	321-0202-00		RES.,FXD,FILM:1.24K OHM,1%,0.125W	91637	MFF1816G12400F
A15R266	321-0289-00		RES.,FXD,FILM:10K OHM,1%,0.125W	91637	MFF1816G10001F
A15R267	311-1241-00		RES.,VAR, NONWIR:100K OHM,10%,0.50W	32997	3386X-T07-104
A15R271	315-0134-00		RES.,FXD,CMPSN:130K OHM,5%,0.25W	01121	CB1345
A15R274	315-0471-00		RES.,FXD,CMPSN:470 OHM,5%,0.25W	01121	CB4715
A15R275	315-0471-00		RES.,FXD,CMPSN:470 OHM,5%,0.25W	01121	CB4715
A15R282	315-0754-00		RES.,FXD,CMPSN:750K OHM,5%,0.25W	01121	CB7545
A15R283	315-0113-00		RES.,FXD,CMPSN:11K OHM,5%,0.25W	01121	CB1135
A15R287	315-0113-00		RES.,FXD,CMPSN:11K OHM,5%,0.25W	01121	CB1135

REPLACEABLE ELECTRICAL PARTS

A15 DEFLECTION AMPLIFIER (CONT)

Component No.	Tektronix Part No.	Serial/Model No. Eff Dscont	Name & Description	Mfr Code	Mfr Part Number
A15R291	315-0202-00		RES., FXD, CMPSN: 2K OHM, 5%, 0.25W	01121	CB2025
A15R296	315-0203-00		RES., FXD, CMPSN: 20K OHM, 5%, 0.25W	01121	CB2035
A15R311	321-0193-00		RES., FXD, FILM: 1K OHM, 1%, 0.125W	91637	MFF1816G10000F
A15R312	321-0277-00		RES., FXD, FILM: 7.5K OHM, 1%, 0.125W	91637	MFF1816G75000F
A15R313	315-0752-00		RES., FXD, CMPSN: 7.5K OHM, 5%, 0.25W	01121	CB7525
A15R314	315-0242-00		RES., FXD, CMPSN: 2.4K OHM, 5%, 0.25W	01121	CB2425
A15R315	315-0752-00		RES., FXD, CMPSN: 7.5K OHM, 5%, 0.25W	01121	CB7525
A15R316	315-0242-00		RES., FXD, CMPSN: 2.4K OHM, 5%, 0.25W	01121	CB2425
A15R317	315-0752-00		RES., FXD, CMPSN: 7.5K OHM, 5%, 0.25W	01121	CB7525
A15R318	315-0242-00		RES., FXD, CMPSN: 2.4K OHM, 5%, 0.25W	01121	CB2425
A15R322	311-1238-00		RES., VAR, NONWIR: 5K OHM, 10%, 0.50W	73138	72-27-0
A15R326	311-1238-00		RES., VAR, NONWIR: 5K OHM, 10%, 0.50W	73138	72-27-0
A15R333	315-0101-00		RES., FXD, CMPSN: 100 OHM, 5%, 0.25W	01121	CB1015
A15R335	315-0102-00		RES., FXD, CMPSN: 1K OHM, 5%, 0.25W	01121	CB1025
A15R337	315-0101-00		RES., FXD, CMPSN: 100 OHM, 5%, 0.25W	01121	CB1015
A15R351	315-0561-00		RES., FXD, CMPSN: 560 OHM, 5%, 0.25W	01121	CB5615
A15R361	315-0561-00		RES., FXD, CMPSN: 560 OHM, 5%, 0.25W	01121	CB5615
A15R381	315-0754-00		RES., FXD, CMPSN: 750K OHM, 5%, 0.25W	01121	CB7545
A15R391	315-0302-00		RES., FXD, CMPSN: 3K OHM, 5%, 0.25W	01121	CB3025
A15R392	315-0432-00		RES., FXD, CMPSN: 4.3K OHM, 5%, 0.25W	01121	CB4325
A15R393	315-0272-00		RES., FXD, CMPSN: 2.7K OHM, 5%, 0.25W	01121	CB2725
A15R411	315-0752-00		RES., FXD, CMPSN: 7.5K OHM, 5%, 0.25W	01121	CB7525
A15R412	315-0242-00		RES., FXD, CMPSN: 2.4K OHM, 5%, 0.25W	01121	CB2425
A15R413	315-0102-00		RES., FXD, CMPSN: 1K OHM, 5%, 0.25W	01121	CB1025
A15R414	315-0682-00		RES., FXD, CMPSN: 6.8K OHM, 5%, 0.25W	01121	CB6825
A15R415	315-0362-00		RES., FXD, CMPSN: 3.6K OHM, 5%, 0.25W	01121	CB3625
A15R423	315-0102-00		RES., FXD, CMPSN: 1K OHM, 5%, 0.25W	01121	CB1025
A15R424	311-1238-00		RES., VAR, NONWIR: 5K OHM, 10%, 0.50W	73138	72-27-0
A15R425	321-0330-00		RES., FXD, FILM: 26.7K OHM, 1%, 0.125W	91637	MFF1816G26701F
A15R426	311-1245-00		RES., VAR, NONWIR: 10K OHM, 10%, 0.50W	73138	72-28-0
A15R431	315-0102-00		RES., FXD, CMPSN: 1K OHM, 5%, 0.25W	01121	CB1025
A15R442	321-0264-00		RES., FXD, FILM: 5.49K OHM, 1%, 0.125W	91637	MFF1816G54900F
A15R443	321-0312-00		RES., FXD, FILM: 17.4K OHM, 1%, 0.125W	91637	MFF1816G17401F
A15R444	321-0397-00		RES., FXD, FILM: 133K OHM, 1%, 0.125W	91637	MFF1816G13302F
A15R445	321-0336-00		RES., FXD, FILM: 30.9K OHM, 1%, 0.125W	91637	MFF1816G30901F
A15R446	321-0386-00		RES., FXD, FILM: 102K OHM, 1%, 0.125W	91637	MFF1816G10202F
A15R447	321-0264-00		RES., FXD, FILM: 5.49K OHM, 1%, 0.125W	91637	MFF1816G54900F
A15R451	315-0114-00		RES., FXD, CMPSN: 110K OHM, 5%, 0.25W	01121	CB1145
A15R452	315-0104-00		RES., FXD, CMPSN: 100K OHM, 5%, 0.25W	01121	CB1045
A15R453	315-0304-00		RES., FXD, CMPSN: 300K OHM, 5%, 0.25W	01121	CB3045
A15R454	315-0103-00		RES., FXD, CMPSN: 10K OHM, 5%, 0.25W	01121	CB1035
A15R457	315-0104-00		RES., FXD, CMPSN: 100K OHM, 5%, 0.25W	01121	CB1045
A15R459	315-0104-00		RES., FXD, CMPSN: 100K OHM, 5%, 0.25W	01121	CB1045
A15R461	315-0114-00		RES., FXD, CMPSN: 110K OHM, 5%, 0.25W	01121	CB1145
A15R462	315-0104-00		RES., FXD, CMPSN: 100K OHM, 5%, 0.25W	01121	CB1045
A15R463	315-0304-00		RES., FXD, CMPSN: 300K OHM, 5%, 0.25W	01121	CB3045
A15R464	315-0103-00		RES., FXD, CMPSN: 10K OHM, 5%, 0.25W	01121	CB1035
A15R467	315-0104-00		RES., FXD, CMPSN: 100K OHM, 5%, 0.25W	01121	CB1045
A15R469	315-0104-00		RES., FXD, CMPSN: 100K OHM, 5%, 0.25W	01121	CB1045
A15R471	315-0103-00		RES., FXD, CMPSN: 10K OHM, 5%, 0.25W	01121	CB1035
A15R472	315-0154-00		RES., FXD, CMPSN: 150K OHM, 5%, 0.25W	01121	CB1545
A15R473	315-0203-00		RES., FXD, CMPSN: 20K OHM, 5%, 0.25W	01121	CB2035
A15R475	315-0154-00		RES., FXD, CMPSN: 150K OHM, 5%, 0.25W	01121	CB1545
A15R476	315-0203-00		RES., FXD, CMPSN: 20K OHM, 5%, 0.25W	01121	CB2035
A15R477	315-0472-00		RES., FXD, CMPSN: 4.7K OHM, 5%, 0.25W	01121	CB4725
A15R481	315-0103-00		RES., FXD, CMPSN: 10K OHM, 5%, 0.25W	01121	CB1035
A15R482	315-0154-00		RES., FXD, CMPSN: 150K OHM, 5%, 0.25W	01121	CB1545

REPLACEABLE ELECTRICAL PARTS

A15 DEFLECTION AMPLIFIER (CONT)

Component No.	Tektronix Part No.	Serial/Model No. Eff Dscnt	Name & Description	Mfr Code	Mfr Part Number
A15R483	315-0203-00		RES.,FXD,CMPSPN:20K OHM,5%,0.25W	01121	CB2035
A15R485	315-0154-00		RES.,FXD,CMPSPN:150K OHM,5%,0.25W	01121	CB1545
A15R486	315-0203-00		RES.,FXD,CMPSPN:20K OHM,5%,0.25W	01121	CB2035
A15R487	315-0472-00		RES.,FXD,CMPSPN:4.7K OHM,5%,0.25W	01121	CB4725
A15R491	315-0103-00		RES.,FXD,CMPSPN:10K OHM,5%,0.25W	01121	CB1035
A15R492	315-0153-00		RES.,FXD,CMPSPN:15K OHM,5%,0.25W	01121	CB1535
A15R493	315-0222-00		RES.,FXD,CMPSPN:2.2K OHM,5%,0.25W	01121	CB2225
A15R495	315-0511-00		RES.,FXD,CMPSPN:510 OHM,5%,0.25W	01121	CB5115
A15R497	315-0203-00		RES.,FXD,CMPSPN:20K OHM,5%,0.25W	01121	CB2035
A15R1000	321-0304-00		RES.,FXD,FILM:14.3K OHM,1%,0.125W	91637	MFF1816G14301F
A15R1100	321-0371-00		RES.,FXD,FILM:71.5K OHM,1%,0.125W	91637	MFF1816G71501F
A15R1103	315-0102-00		RES.,FXD,CMPSPN:1K OHM,5%,0.25W	01121	CB1025
A15R1105	315-0183-00		RES.,FXD,CMPSPN:18K OHM,5%,0.25W	01121	CB1835
A15R1107	315-0102-00		RES.,FXD,CMPSPN:1K OHM,5%,0.25W	01121	CB1025
A15R1108	315-0103-00		RES.,FXD,CMPSPN:10K OHM,5%,0.25W	01121	CB1035
A15R1203	315-0303-00		RES.,FXD,CMPSPN:30K OHM,5%,0.25W	01121	CB3035
A15R1213	321-0335-00		RES.,FXD,FILM:30.1K OHM,1%,0.125W	91637	MFF1816G30101F
A15R1314	315-0102-00		RES.,FXD,CMPSPN:1K OHM,5%,0.25W	01121	CB1025
A15R1315	315-0103-00		RES.,FXD,CMPSPN:10K OHM,5%,0.25W	01121	CB1035
A15R1415	321-0193-00		RES.,FXD,FILM:1K OHM,1%,0.125W	91637	MFF1816G10000F
A15U228	155-0154-00		MICROCIRCUIT,LI:CHANNEL SWITCH	80009	155-0154-00
A15U256	156-0317-02		MICROCIRCUIT,LI:OPERATIONAL AMPLIFIER	34371	HA2-2625-5
A15U266	156-0317-02		MICROCIRCUIT,LI:OPERATIONAL AMPLIFIER	34371	HA2-2625-5
A15U293	156-0096-02		MICROCIRCUIT,LI:VOLTAGE COMPARATOR,SCRN	27014	LM311H/A+
A15U342	155-0152-01		MICROCIRCUIT,LI:GEOMETRY & FOCUS CORR	80009	155-0152-01
A15U353	156-0742-02		MICROCIRCUIT,LI:OPERATIONAL AMPLIFIER,SEL	01295	LM318P3
A15U363	156-0742-02		MICROCIRCUIT,LI:OPERATIONAL AMPLIFIER,SEL	01295	LM318P3
A15U373	156-0742-02		MICROCIRCUIT,LI:OPERATIONAL AMPLIFIER,SEL	01295	LM318P3
A15U383	156-0742-02		MICROCIRCUIT,LI:OPERATIONAL AMPLIFIER,SEL	01295	LM318P3
A15U393	156-0742-02		MICROCIRCUIT,LI:OPERATIONAL AMPLIFIER,SEL	01295	LM318P3
A15U1002	156-0733-02		MICROCIRCUIT,DI:DUAL MONOSTABLE MV,SCRN	04713	SN74LS221N/J
A15U1311	156-0072-02		MICROCIRCUIT,DI:MONOSTABLE MV,BURN-IN	01295	SN74121
A15VR136	152-0166-00		SEMICONV DEVICE:ZENER,0.4W,6.2V,5%	04713	SZ11738
A15VR138	152-0166-00		SEMICONV DEVICE:ZENER,0.4W,6.2V,5%	04713	SZ11738
A15VR186	152-0166-00		SEMICONV DEVICE:ZENER,0.4W,6.2V,5%	04713	SZ11738
A15VR188	152-0166-00		SEMICONV DEVICE:ZENER,0.4W,6.2V,5%	04713	SZ11738
A15VR210	152-0166-00		SEMICONV DEVICE:ZENER,0.4W,6.2V,5%	04713	SZ11738
A15VR211	152-0166-00		SEMICONV DEVICE:ZENER,0.4W,6.2V,5%	04713	SZ11738
A15VR456	152-0195-00		SEMICONV DEVICE:ZENER,0.4W,5.1V,5%	04713	SZ11755
A15VR458	152-0195-00		SEMICONV DEVICE:ZENER,0.4W,5.1V,5%	04713	SZ11755
A15VR466	152-0195-00		SEMICONV DEVICE:ZENER,0.4W,5.1V,5%	04713	SZ11755
A15VR468	152-0195-00		SEMICONV DEVICE:ZENER,0.4W,5.1V,5%	04713	SZ11755

REPLACEABLE ELECTRICAL PARTS

Component No.	Tektronix Part No.	Serial/Model No. Eff Dscont	Name & Description	Mfr Code	Mfr Part Number
A16 HIGH VOLTAGE AND Z AXIS					
A16	672-0662-04		CKT BOARD ASSY:HIGH VOLTAGE & Z AXIS	80009	672-0662-04
A16A1	670-4804-XX		(NOT AVAILABLE, SEE A16)		
A16C13	290-0745-00		CAP.,FXD,ELCTLT:22UF,+50-10%,25V	56289	502D225
A16C16	290-0745-00		CAP.,FXD,ELCTLT:22UF,+50-10%,25V	56289	502D225
A16C19	290-0745-00		CAP.,FXD,ELCTLT:22UF,+50-10%,25V	56289	502D225
A16C25	281-0775-00		CAP.,FXD,CER DI:0.1UF,20%,50V	04222	SA205E104MAA
A16C44	285-0604-00		CAP.,FXD,PLSTC:0.01UF,20%,400V	01002	64F22DB103
A16C45	285-0604-00		CAP.,FXD,PLSTC:0.01UF,20%,400V	01002	64F22DB103
A16C55	290-0312-00		CAP.,FXD,ELCTLT:47UF,10%,35V	56289	150D476X9035S2
A16C67	281-0775-00		CAP.,FXD,CER DI:0.1UF,20%,50V	04222	SA205E104MAA
A16C75	285-1137-00		CAP.,FXD,PLSTC:0.0047UF,10%,8000V	56289	430P472980
A16C97	285-0507-01		CAP.,FXD,PPR DI:0.0047UF,20%,6000V	56289	430P472060
A16C126	281-0763-00		CAP.,FXD,CER DI:47PF,10%,100V	72982	8035D9AADC1G470K
A16C137	281-0755-00		CAP.,FXD,CER DI:1.8PF,0.1%,500V	72982	314021COK0189B
A16C146	283-0001-00		CAP.,FXD,CER DI:0.005UF,+100-0%,500V	72982	831-559E502P
A16C175	285-1136-00		CAP.,FXD,PLSTC:0.001UF,10%,8000V	56289	430P559
A16C176	285-1137-00		CAP.,FXD,PLSTC:0.0047UF,10%,8000V	56289	430P472980
A16C177	285-1136-00		CAP.,FXD,PLSTC:0.001UF,10%,8000V	56289	430P559
A16C178	285-1136-00		CAP.,FXD,PLSTC:0.001UF,10%,8000V	56289	430P559
A16C181	283-0363-00		CAP.,FXD,CER DI:2.2PF,0.25%,2KV	72982	838-000COK229C
A16C182	283-0363-00		CAP.,FXD,CER DI:2.2PF,0.25%,2KV	72982	838-000COK229C
A16C215	281-0775-00		CAP.,FXD,CER DI:0.1UF,20%,50V	04222	SA205E104MAA
A16C245	285-1119-00		CAP.,FXD,PLSTC:0.082UF,10%,200V	19396	PP680C823K
A16C246	281-0619-00		CAP.,FXD,CER DI:1.2PF,+/-0.1PF,200V	59660	374 018 COK0129B
A16C335	281-0524-00		CAP.,FXD,CER DI:150PF,+/-30PF,500V	04222	7001-1381
A16C371	281-0812-00		CAP.,FXD,CER DI:1000PF,10%,100V	72982	8035D9AADX7R102K
A16C372	285-1136-00		CAP.,FXD,PLSTC:0.001UF,10%,8000V	56289	430P559
A16C373	285-1136-00		CAP.,FXD,PLSTC:0.001UF,10%,8000V	56289	430P559
A16C419	281-0775-00		CAP.,FXD,CER DI:0.1UF,20%,50V	04222	SA205E104MAA
A16C428	285-0572-00		CAP.,FXD,PLSTC:0.1UF,20%,200V	56289	410P10402
A16C439	281-0773-00		CAP.,FXD,CER DI:0.01UF,10%,100V	04222	GC70-1C103K
A16C455	281-0771-00		CAP.,FXD,CER DI:0.0022UF,20%,200V	56289	292C Z5U222M200B
A16C457	290-0745-00		CAP.,FXD,ELCTLT:22UF,+50-10%,25V	56289	502D225
A16C459	290-0745-00		CAP.,FXD,ELCTLT:22UF,+50-10%,25V	56289	502D225
A16C466	281-0797-00		CAP.,FXD,CER DI:15PF,10%,100V	72982	8035D9AADC0G150K
A16C469	281-0788-00		CAP.,FXD,CER DI:470PF,10%,100V	72982	8005H9AADW5R471K
A16C472	281-0775-00		CAP.,FXD,CER DI:0.1UF,20%,50V	04222	SA205E104MAA
A16C473	290-0247-00		CAP.,FXD,ELCTLT:5.6UF,10%,6V	56289	162D565X9006CD2
A16C474	283-0280-00		CAP.,FXD,CER DI:2200PF,10%,2000V	59660	0818590Y5500222K
A16C475	285-1138-00		CAP.,FXD,PLSTC:0.01UF,10%,8000V	56289	430P558
A16CR43	152-0107-00		SEMICONV DEVICE:SILICON,400V,400MA	01295	G727
A16CR91	152-0639-00		SEMICONV DEVICE:RECT,SI,10KV,10MA	52306	CX345
A16CR95	152-0639-00		SEMICONV DEVICE:RECT,SI,10KV,10MA	52306	CX345
A16CR148	152-0107-00		SEMICONV DEVICE:SILICON,400V,400MA	01295	G727
A16CR164	152-0107-00		SEMICONV DEVICE:SILICON,400V,400MA	01295	G727
A16CR165	152-0061-00		SEMICONV DEVICE:SILICON,175V,100MA	07263	FDH2161
A16CR166	152-0061-00		SEMICONV DEVICE:SILICON,175V,100MA	07263	FDH2161
A16CR168	152-0107-00		SEMICONV DEVICE:SILICON,400V,400MA	01295	G727
A16CR169	152-0107-00		SEMICONV DEVICE:SILICON,400V,400MA	01295	G727
A16CR199	152-0242-00		SEMICONV DEVICE:SILICON,225V,200MA	07263	FDH5004
A16CR270	152-0751-00		SEMICONV DEVICE:RECT,SI,SWITCHING,265V,DO-7	14552	TD13419
A16CR273	152-0751-00		SEMICONV DEVICE:RECT,SI,SWITCHING,265V,DO-7	14552	TD13419
A16CR290	152-0242-00		SEMICONV DEVICE:SILICON,225V,200MA	07263	FDH5004
A16CR315	152-0141-02		SEMICONV DEVICE:SILICON,30V,150MA	01295	1N4152R
A16CR324	152-0141-02		SEMICONV DEVICE:SILICON,30V,150MA	01295	1N4152R

REPLACEABLE ELECTRICAL PARTS

A16 HIGH VOLTAGE AND Z AXIS (CONT)

Component No.	Tektronix Part No.	Serial/Model No. Eff Dscnt	Name & Description	Mfr Code	Mfr Part Number
A16CR325	152-0141-02		SEMICON D DEVICE:SILICON,30V,150MA	01295	1N4152R
A16CR326	152-0141-02		SEMICON D DEVICE:SILICON,30V,150MA	01295	1N4152R
A16CR328	152-0141-02		SEMICON D DEVICE:SILICON,30V,150MA	01295	1N4152R
A16CR329	152-0141-02		SEMICON D DEVICE:SILICON,30V,150MA	01295	1N4152R
A16CR334	152-0141-02		SEMICON D DEVICE:SILICON,30V,150MA	01295	1N4152R
A16CR339	152-0141-02		SEMICON D DEVICE:SILICON,30V,150MA	01295	1N4152R
A16CR356	152-0141-02		SEMICON D DEVICE:SILICON,30V,150MA	01295	1N4152R
A16CR426	152-0141-02		SEMICON D DEVICE:SILICON,30V,150MA	01295	1N4152R
A16CR427	152-0141-02		SEMICON D DEVICE:SILICON,30V,150MA	01295	1N4152R
A16CR435	152-0141-02		SEMICON D DEVICE:SILICON,30V,150MA	01295	1N4152R
A16CR457	152-0141-02		SEMICON D DEVICE:SILICON,30V,150MA	01295	1N4152R
A16DS393	150-0035-00		LAMP,GLOW:90V,0.3MA	53944	A1B-3
A16DS494	150-0035-00		LAMP,GLOW:90V,0.3MA	53944	A1B-3
A16DS495	150-0035-00		LAMP,GLOW:90V,0.3MA	53944	A1B-3
A16F21	159-0022-00		FUSE,CARTRIDGE:3AG,1A,250V,FAST-BLOW	71400	AGC 1
A16L41	108-0422-00		COIL,RF:FIXED,82UH	80009	108-0422-00
A16Q35	151-0188-00		TRANSISTOR:SILICON,PNP	04713	SPS6868K
A16Q53	151-0469-00		TRANSISTOR:SILICON,NPN	04713	SJE1101
A16Q115	151-0190-00		TRANSISTOR:SILICON,NPN	07263	S032677
A16Q130	151-0190-00		TRANSISTOR:SILICON,NPN	07263	S032677
A16Q132	151-0190-00		TRANSISTOR:SILICON,NPN	07263	S032677
A16Q141	151-0444-00		TRANSISTOR:SILICON,NPN	80009	151-0444-00
A16Q145	151-0443-00		TRANSISTOR:SILICON,PNP	80009	151-0443-00
A16Q266	151-0347-00		TRANSISTOR:SILICON,NPN	56289	2N5551
A16Q269	151-0350-00		TRANSISTOR:SILICON,PNP	04713	SPS6700
A16Q445	151-0188-00		TRANSISTOR:SILICON,PNP	04713	SPS6868K
A16Q446	151-0188-00		TRANSISTOR:SILICON,PNP	04713	SPS6868K
A16Q465	151-0188-00		TRANSISTOR:SILICON,PNP	04713	SPS6868K
A16R5	307-0104-00		RES.,FXD,CMPSN:3.3 OHM,5%,0.25W	01121	CB33G5
A16R7	315-0100-00		RES.,FXD,CMPSN:10 OHM,5%,0.25W	01121	CB1005
A16R9	315-0472-03		RES.,FXD,CMPSN:4.7K OHM,5%,0.25W	01121	CB4725
A16R25	315-0472-03		RES.,FXD,CMPSN:4.7K OHM,5%,0.25W	01121	CB4725
A16R26	315-0472-03		RES.,FXD,CMPSN:4.7K OHM,5%,0.25W	01121	CB4725
A16R34	311-1556-00		RES.,VAR,NONWIR:50K OHM,20%,0.50W	73138	91-78-0
A16R36	315-0103-03		RES.,FXD,CMPSN:10K OHM,5%,0.25W	01121	CB1035
A16R37	315-0204-00		RES.,FXD,CMPSN:200K OHM,5%,0.25W	01121	CB2045
A16R38	315-0105-00		RES.,FXD,CMPSN:1M OHM,5%,0.25W	01121	CB1055
A16R39	315-0103-03		RES.,FXD,CMPSN:10K OHM,5%,0.25W	01121	CB1035
A16R44	301-0240-00		RES.,FXD,CMPSN:24 OHM,5%,0.50W	01121	EB2405
A16R47	315-0623-00		RES.,FXD,CMPSN:62K OHM,5%,0.25W	01121	CB6235
A16R61	315-0100-00		RES.,FXD,CMPSN:10 OHM,5%,0.25W	01121	CB1005
A16R70	307-0104-00		RES.,FXD,CMPSN:3.3 OHM,5%,0.25W	01121	CB33G5
A16R73	315-0271-03		RES.,FXD,CMPSN:270 OHM,5%,0.25W	01121	CB2715
A16R110	315-0271-03		RES.,FXD,CMPSN:270 OHM,5%,0.25W	01121	CB2715
A16R115	315-0472-03		RES.,FXD,CMPSN:4.7K OHM,5%,0.25W	01121	CB4725
A16R116	315-0750-00		RES.,FXD,CMPSN:75 OHM,5%,0.25W	01121	CB7505
A16R117	315-0151-00		RES.,FXD,CMPSN:150 OHM,5%,0.25W	01121	CB1515
A16R118	315-0820-00		RES.,FXD,CMPSN:82 OHM,5%,0.25W	01121	CB8205
A16R120	315-0151-00		RES.,FXD,CMPSN:150 OHM,5%,0.25W	01121	CB1515
A16R126	321-0231-00		RES.,FXD,FILM:2.49K OHM,1%,0.125W	91637	MFF1816G24900F
A16R127	321-0301-00		RES.,FXD,FILM:13.3K OHM,1%,0.125W	91637	MFF1816G13301F
A16R128	311-1556-00		RES.,VAR,NONWIR:50K OHM,20%,0.50W	73138	91-78-0
A16R133	301-0911-00		RES.,FXD,CMPSN:910 OHM,5%,0.50W	01121	EB9115
A16R134	315-0182-00		RES.,FXD,CMPSN:1.8K OHM,5%,0.25W	01121	CB1825
A16R135	315-0471-00		RES.,FXD,CMPSN:470 OHM,5%,0.25W	01121	CB4715
A16R147	315-0271-03		RES.,FXD,CMPSN:270 OHM,5%,0.25W	01121	CB2715
A16R167	301-0203-00		RES.,FXD,CMPSN:20K OHM,5%,0.50W	01121	EB2035

REPLACEABLE ELECTRICAL PARTS

A16 HIGH VOLTAGE AND Z AXIS (CONT)

Component No.	Tektronix Part No.	Serial/Model No. Eff Dscnt	Name & Description	Mfr Code	Mfr Part Number
A16R169	301-0105-00		RES.,FXD,CMPSN:1M OHM,5%,0.50W	01121	EB1055
A16R170	301-0514-00		RES.,FXD,CMPSN:510K OHM,5%,0.50W	01121	EB5145
A16R175	315-0271-03		RES.,FXD CMPSN:270 OHM,5%,0.25W	01121	CB2715
A16R176	315-0103-03		RES.,FXD,CMPSN:10K OHM,5%,0.25W	01121	CB1035
A16R177	315-0271-03		RES.,FXD CMPSN:270 OHM,5%,0.25W	01121	CB2715
A16R178	315-0102-03		RES.,FXD,CMPSN:1K OHM,5%,0.25W	01121	CB1025
A16R196	315-0472-03		RES.,FXD,CMPSN:4.7K OHM,5%,0.25W	01121	CB4725
A16R198	315-0303-03		RES.,FXD,CMPSN:30K OHM,5%,0.25W	01121	CB3035
A16R215	321-0322-00		RES.,FXD,FILM:22.1K OHM,1%,0.125W	91637	MFF1816G22101F
A16R216	321-0251-00		RES.,FXD,FILM:4.02K OHM,1%,0.125W	91637	MFF1816G40200F
A16R217	315-0221-00		RES.,FXD,CMPSN:220 OHM,5%,0.25W	01121	CB2215
A16R219	307-0104-00		RES.,FXD,CMPSN:3.3 OHM,5%,0.25W	01121	CB33G5
A16R225	321-0330-00		RES.,FXD,FILM:26.7K OHM,1%,0.125W	91637	MFF1816G26701F
A16R226	311-1934-00		RES.,VAR,NONWIR:PNL,2K OHM,20%,0.50W	01121	15M906
A16R227	311-1934-00		RES.,VAR,NONWIR:PNL,2K OHM,20%,0.50W	01121	15M906
A16R235	323-0452-00		RES.,FXD,FILM:499K OHM,1%,0.50W	75042	CECT0-4993F
A16R236	321-0431-00		RES.,FXD,FILM:301K OHM,1%,0.125W	91637	MFF1816G30102F
A16R246	323-0318-00		RES.,FXD,FILM:20K OHM,1%,0.50W	91637	MFF1226D20001F
A16R270	315-0303-03		RES.,FXD,CMPSN:30K OHM,5%,0.25W	01121	CB3035
A16R271	315-0226-00		RES.,FXD,CMPSN:22M OHM,5%,0.25W	01121	CB2265
A16R272	315-0303-03		RES.,FXD,CMPSN:30K OHM,5%,0.25W	01121	CB3035
A16R288	311-1933-00		RES.,VAR,NONWIR:PNL,5M OHM,10%,0.50W	01121	17M095
A16R291	315-0303-03		RES.,FXD,CMPSN:30K OHM,5%,0.25W	01121	CB3035
A16R292	315-0226-00		RES.,FXD,CMPSN:22M OHM,5%,0.25W	01121	CB2265
A16R325	315-0823-00		RES.,FXD,CMPSN:82K OHM,5%,0.25W	01121	CB8235
A16R334	315-0184-00		RES.,FXD,CMPSN:180K OHM,5%,0.25W	01121	CB1845
A16R336	315-0101-03		RES.,FXD,CMPSN:100 OHM,5%,0.25W	01121	CB1015
A16R337	315-0162-00		RES.,FXD,CMPSN:1.6K OHM,5%,0.25W	01121	CB1625
A16R344	323-0408-00		RES.,FXD,FILM:174K OHM,1%,0.50W	91637	MFF1226G17402F
A16R345	323-0408-00		RES.,FXD,FILM:174K OHM,1%,0.50W	91637	MFF1226G17402F
A16R346	315-0102-03		RES.,FXD,CMPSN:1K OHM,5%,0.25W	01121	CB1025
A16R347	315-0151-00		RES.,FXD,CMPSN:150 OHM,5%,0.25W	01121	CB1515
A16R355	315-0182-00		RES.,FXD,CMPSN:1.8K OHM,5%,0.25W	01121	CB1825
A16R365	323-0338-00		RES.,FXD,FILM:32.4K OHM,1%,0.50W	75042	CECT0-3242F
A16R366	315-0273-00		RES.,FXD,CMPSN:27K OHM,5%,0.25W	01121	CB2735
A16R367	315-0122-00		RES.,FXD,CMPSN:1.2K OHM,5%,0.25W	01121	CB1225
A16R368	315-0181-00		RES.,FXD,CMPSN:180 OHM,5%,0.25W	01121	CB1815
A16R369	321-0272-00		RES.,FXD,FILM:6.65K OHM,1%,0.125W	91637	MFF1816G66500F
A16R375	315-0102-03		RES.,FXD,CMPSN:1K OHM,5%,0.25W	01121	CB1025
A16R415	311-1562-00		RES.,VAR,NONWIR:2K OHM,20%,0.50W	73138	91-84-0
A16R416	321-0272-00		RES.,FXD,FILM:6.65K OHM,1%,0.125W	91637	MFF1816G66500F
A16R417	321-0322-00		RES.,FXD,FILM:22.1K OHM,1%,0.125W	91637	MFF1816G22101F
A16R418	315-0472-03		RES.,FXD,CMPSN:4.7K OHM,5%,0.25W	01121	CB4725
A16R425	321-0251-00		RES.,FXD,FILM:4.02K OHM,1%,0.125W	91637	MFF1816G40200F
A16R426	321-0243-00		RES.,FXD,FILM:3.32K OHM,1%,0.125W	91637	MFF1816G33200F
A16R427	311-1562-00		RES.,VAR,NONWIR:2K OHM,20%,0.50W	73138	91-84-0
A16R428	321-0251-00		RES.,FXD,FILM:4.02K OHM,1%,0.125W	91637	MFF1816G40200F
A16R429	311-1555-00		RES.,VAR,NONWIR:100K OHM,20%,0.5W	73138	91-77-0
A16R436	321-0289-00		RES.,FXD,FILM:10K OHM,1%,0.125W	91637	MFF1816G10001F
A16R437	321-0251-00		RES.,FXD,FILM:4.02K OHM,1%,0.125W	91637	MFF1816G40200F
A16R446	303-0823-00		RES.,FXD,CMPSN:82K OHM,5%,1W	01121	GB8235
A16R447	323-0333-00		RES.,FXD,FILM:28.7K OHM,1%,0.50W	75042	CECT0-2872F
A16R448	323-0365-00		RES.,FXD,FILM:61.9K OHM,1%,0.50W	75042	CECT0-6192F
A16R449	323-0365-00		RES.,FXD,FILM:61.9K OHM,1%,0.50W	75042	CECT0-6192F
A16R456	315-0103-03		RES.,FXD,CMPSN:10K OHM,5%,0.25W	01121	CB1035
A16R457	315-0103-03		RES.,FXD,CMPSN:10K OHM,5%,0.25W	01121	CB1035
A16R466	315-0152-00		RES.,FXD,CMPSN:1.5K OHM,5%,0.25W	01121	CB1525

REPLACEABLE ELECTRICAL PARTS

A16 HIGH VOLTAGE AND Z AXIS (CONT)

Component No.	Tektronix Part No.	Serial/Model No. Eff Dscont	Name & Description	Mfr Code	Mfr Part Number
A16R467	315-0204-00		RES., FXD, CMPSN:200K OHM, 5%, 0.25W	01121	CB2045
A16R468	315-0333-00		RES., FXD, CMPSN:33K OHM, 5%, 0.25W	01121	CB3335
A16R472	315-0823-00		RES., FXD, CMPSN:82K OHM, 5%, 0.25W	01121	CB8235
A16R474	315-0102-03		RES., FXD, CMPSN:1K OHM, 5%, 0.25W	01121	CB1025
A16R475	315-0103-03		RES., FXD, CMPSN:10K OHM, 5%, 0.25W	01121	CB1035
A16R476	307-0550-01		RES NTWK, FXD FI:HV DIVIDER	80009	307-0550-01
A16T75	120-1140-00		XFMR, PWR, SDN&SU:HIGH VOLTAGE	80009	120-1140-00
A16U25	152-0751-00		SEMICONV DEVICE:RECT, SI, SWITCHING, 265V, DO-7	14552	TD13419
A16U115	156-0058-01		MICROCIRCUIT, DI:HEX INVERTER	80009	156-0058-01
A16U125	156-0072-01		MICROCIRCUIT, LI:MONOSTABLE MV, CHK	80009	156-0072-01
A16U475	156-0067-00		MICROCIRCUIT, LI:OPERATIONAL AMPLIFIER	01295	MICROA741CP

REPLACEABLE ELECTRICAL PARTS

Component No.	Tektronix Part No.	Serial/Model No. Eff Dscont	Name & Description	Mfr Code	Mfr Part Number
A17 POWER SUPPLY					
A17	620-0294-00	B010100 B021324	POWER SUPPLY:	80009	620-0294-00
A17	620-0294-01	B021325	POWER SUPPLY:	80009	620-0294-01
A17C435	283-0008-00	XB021325	CAP., FXD, CER DI: 0.1UF, 20%, 500V	56289	2C37X7R104M501B2
A17C1001	283-0167-00		CAP., FXD, CER DI: 0.1UF, 10%, 100V	72982	8131N145X5R0104K
A17C1004	283-0167-00		CAP., FXD, CER DI: 0.1UF, 10%, 100V	72982	8131N145X5R0104K
A17CR1001	152-0721-00		SEMICONV DEVICE: RECT, SI, 100V, 12A, FAST REC	25403	BYW30-100U
A17CR1002	152-0714-00		SEMICONV DEVICE: RECT, SI, SCHOTTKY, 40V, 50A	01281	1N6098
A17CR1003	152-0714-00		SEMICONV DEVICE: RECT, SI, SCHOTTKY, 40V, 50A	01281	1N6098
A17CR1004	152-0721-00		SEMICONV DEVICE: RECT, SI, 100V, 12A, FAST REC	25403	BYW30-100U
A17E1002	276-0635-00	XB021325	CORE, EM: TOROID, FERRITE	08057	7J-41405-TC
A17F3001	159-0201-00	-----	FUSE, CARTRIDGE: 3AG, 10A, 125V, 5 SEC (4114 ONLY)	71400	GLH-10
A17F3001	159-0014-00	-----	FUSE, CARTRIDGE: 3AG, 5A, 250V, FAST-BLOW (OPTION A1, A2, A3, A4)	71400	MTH5
A17FL1001	119-1348-00		FILTER, RFI: 10A, 115/250V	13050	605C10
A17FL1002	119-1168-00	XB021325	CAPACITOR-RES: 0.1UF, 20% & 22 OHM, 10%, 250V	14752	RG1782-1
A17J3001	131-1084-00		CONNECTOR, RCPT, : 3 BLADE, 6A, 250V	82389	EAC-302
A17J3002	131-1234-00		CONN, RCPT, ELEC: PWR, FEMALE, 250VAC, 6A	82389	EAC-305
A17L1001	108-1069-00		COIL, RF: FIXED, 20UH	80009	108-1069-00
A17Q710	153-0652-00		TRANSISTOR: MJE13009, SCREENED	80009	153-0652-00
A17Q720	153-0652-00		TRANSISTOR: MJE13009, SCREENED	80009	153-0652-00
A17Q741	151-0657-00		TRANSISTOR: SILICON, PNP	04713	SJE1973
A17Q751	151-0656-00		TRANSISTOR: SILICON, NPN	04713	SJE1972
A17Q761	151-0528-00		TRANSISTOR: SILICON, 50V, 16A	04713	2N6400
A17Q771	151-0657-00		TRANSISTOR: SILICON, PNP	04713	SJE1973
A17Q785	151-0656-00		TRANSISTOR: SILICON, NPN	04713	SJE1972
A17Q795	151-0477-00		TRANSISTOR: SILICON, NPN	04713	SJE374
A17R1001	307-0004-00		RES., FXD, CMPSN: 3.9 OHM, 5%, 1W	23223	C10L-120000K
A17R1004	307-0004-00		RES., FXD, CMPSN: 3.9 OHM, 5%, 1W	23223	C10L-120000K
A17A1	670-6503-01	B010100 B010804	CKT BOARD ASSY: INVERTER	80009	670-6503-01
A17A1	670-6503-02	B010805 B021324	CKT BOARD ASSY: INVERTER	80009	670-6503-02
A17A1	670-6503-03	B021325	CKT BOARD ASSY: INVERTER	80009	670-6503-03
A17A1C105	283-0177-00		CAP., FXD, CER DI: 1UF, +80-20%, 25V	56289	273C5
A17A1C135	283-0067-00		CAP., FXD, CER DI: 0.001UF, 10%, 200V	59660	835-515-Z5D0102K
A17A1C137	283-0060-00		CAP., FXD, CER DI: 100PF, 5%, 200V	72982	855-535U2J101J
A17A1C145	290-0829-00		CAP., FXD, ELCTLT: 750UF, +100-10%, 200V	90201	FPF751SR2J3P2
A17A1C160	290-0829-00		CAP., FXD, ELCTLT: 750UF, +100-10%, 200V	90201	FPF751SR2J3P2
A17A1C174	281-0775-00		CAP., FXD, CER DI: 0.1UF, 20%, 50V	04222	SA205E104MAA
A17A1C175	290-0817-00		CAP., FXD, ELCTLT: 100UF, +50-10%, 63V	55680	NCA63ELB100-T
A17A1C249	283-0057-00		CAP., FXD, CER DI: 0.1UF, +80-20%, 200V	56289	2C20Z5U104Z200B
A17A1C345	290-0829-00		CAP., FXD, ELCTLT: 750UF, +100-10%, 200V	90201	FPF751SR2J3P2
A17A1C360	290-0829-00		CAP., FXD, ELCTLT: 750UF, +100-10%, 200V	90201	FPF751SR2J3P2
A17A1C384	283-0057-00	XB021325	CAP., FXD, CER DI: 0.1UF, +80-20%, 200V	56289	2C20Z5U104Z200B
A17A1C471	285-1133-00		CAP., FXD, PLSTC: 0.33UF, 1%, 100V	50558	MH12D334F
A17A1C472	283-0177-00		CAP., FXD, CER DI: 1UF, +80-20%, 25V	56289	273C5
A17A1C473	283-0134-00		CAP., FXD, CER DI: 0.47UF, +80-20%, 50V	72982	8131N087Z5U0474Z
A17A1C501	285-1203-00		CAP., FXD, PLSTC: 4UF, 10%, 200V	14952	C2551
A17A1C520	285-1203-00		CAP., FXD, PLSTC: 4UF, 10%, 200V	14952	C2551
A17A1C545	290-0829-00		CAP., FXD, ELCTLT: 750UF, +100-10%, 200V	90201	FPF751SR2J3P2
A17A1C560	290-0829-00		CAP., FXD, ELCTLT: 750UF, +100-10%, 200V	90201	FPF751SR2J3P2
A17A1C577	283-0067-00	B010100 B021324X	CAP., FXD, CER DI: 0.001UF, 10%, 200V	59660	835-515-Z5D0102K
A17A1C581	283-0190-00		CAP., FXD, CER DI: 0.47UF, 5%, 50V	72982	8141N077X7R0474J
A17A1C589	283-0057-00	XB021325	CAP., FXD, CER DI: 0.1UF, +80-20%, 200V	56289	2C20Z5U104Z200B

REPLACEABLE ELECTRICAL PARTS

A17A1 INVERTER (CONT)

Component No.	Tektronix Part No.	Serial/Model No. Eff Dscnt	Name & Description	Mfr Code	Mfr Part Number
A17A1C609	283-0659-00		CAP.,FXD,MICA D:1160PF,2%,500V	00853	D195F1161G0
A17A1C629	283-0057-00		CAP.,FXD,CER DI:0.1UF,+80-20%,200V	56289	2C20Z5U104Z200B
A17A1C630	283-0057-00		CAP.,FXD,CER DI:0.1UF,+80-20%,200V	56289	2C20Z5U104Z200B
A17A1C631	283-0194-00		CAP.,FXD,CER DI:4.7UF,20%,50V	56289	5C37Z5U475M050B
A17A1C643	285-1192-00		CAP.,FXD,PPR DI:0.0022UF,20%,250VAC	000FG	PME271Y422
A17A1C669	283-0328-00		CAP.,FXD,CER DI:0.03UF,+80-20%,200V	72982	8131N225Z5U0303Z
A17A1C673	283-0077-00	B010100 B012199	CAP.,FXD,CER DI:330PF,5%,500V	59660	831-500B331J
A17A1C673	283-0150-00	B010200 B010804	CAP.,FXD,CER DI:650PF,5%,200V	59660	835-515B651J
A17A1C673	283-0116-00	B010805	CAP.,FXD,CER DI:820PF,5%,500V	72982	801-547B821J
A17A1C733	283-0194-00		CAP.,FXD,CER DI:4.7UF,20%,50V	56289	5C37Z5U475M050B
A17A1C751	283-0067-00	XB021325	CAP.,FXD,CER DI:0.001UF,10%,200V	59660	835-515-25D0102K
A17A1C758	283-0134-00	B010100 B021324X	CAP.,FXD,CER DI:0.47UF,+80-20%,50V	72982	8131N087Z5U0474Z
A17A1C773	285-0598-00		CAP.,FXD,PLSTC:0.01UF,5%,100V	19396	DU490B103J
A17A1C780	283-0067-00	B010100 B021324	CAP.,FXD,CER DI:0.001UF,10%,200V	59660	835-515-25D0102K
A17A1C780	283-0221-00	B021325	CAP.,FXD,CER DI:0.47UF,20%,50V	72982	8131N087X7R0474M
A17A1C785	283-0422-00		CAP.,FXD,CER DI:0.047UF,+80-20%,50V	04222	DG015E473Z
A17A1CR106	152-0141-02		SEMICONV DEVICE:SILICON,30V,150MA	01295	1N4152R
A17A1CR107	152-0141-02		SEMICONV DEVICE:SILICON,30V,150MA	01295	1N4152R
A17A1CR108	152-0141-02		SEMICONV DEVICE:SILICON,30V,150MA	01295	1N4152R
A17A1CR109	152-0141-02		SEMICONV DEVICE:SILICON,30V,150MA	01295	1N4152R
A17A1CR125	152-0333-00		SEMICONV DEVICE:SILICON,55V,200MA	07263	FDH-6012
A17A1CR126	152-0333-00		SEMICONV DEVICE:SILICON,55V,200MA	07263	FDH-6012
A17A1CR127	152-0333-00		SEMICONV DEVICE:SILICON,55V,200MA	07263	FDH-6012
A17A1CR128	152-0333-00		SEMICONV DEVICE:SILICON,55V,200MA	07263	FDH-6012
A17A1CR180	152-0333-00		SEMICONV DEVICE:SILICON,55V,200MA	07263	FDH-6012
A17A1CR181	152-0333-00		SEMICONV DEVICE:SILICON,55V,200MA	07263	FDH-6012
A17A1CR227	152-0141-02		SEMICONV DEVICE:SILICON,30V,150MA	01295	1N4152R
A17A1CR325	152-0713-00		SEMICONV DEVICE:RECT BRIDGE,SI,400V,35A	04713	SDA10388K
A17A1CR375	152-0398-00	XB021325	SEMICONV DEVICE:SILICON,200V,1A	04713	SR3609RL
A17A1CR471	152-0141-02		SEMICONV DEVICE:SILICON,30V,150MA	01295	1N4152R
A17A1CR477	152-0141-02		SEMICONV DEVICE:SILICON,30V,150MA	01295	1N4152R
A17A1CR478	152-0141-02		SEMICONV DEVICE:SILICON,30V,150MA	01295	1N4152R
A17A1CR615	152-0400-00		SEMICONV DEVICE:SILICON,400V,1A	80009	152-0400-00
A17A1CR629	152-0400-00		SEMICONV DEVICE:SILICON,400V,1A	80009	152-0400-00
A17A1CR630	152-0400-00		SEMICONV DEVICE:SILICON,400V,1A	80009	152-0400-00
A17A1CR661	152-0071-00		SEMICONV DEVICE:GERMANIUM,15V,40MA	15238	G865
A17A1CR663	152-0071-00		SEMICONV DEVICE:GERMANIUM,15V,40MA	15238	G865
A17A1CR671	152-0071-00		SEMICONV DEVICE:GERMANIUM,15V,40MA	15238	G865
A17A1CR701	152-0400-00		SEMICONV DEVICE:SILICON,400V,1A	80009	152-0400-00
A17A1CR729	152-0400-00		SEMICONV DEVICE:SILICON,400V,1A	80009	152-0400-00
A17A1CR751	152-0242-00		SEMICONV DEVICE:SILICON,225V,200MA	07263	FDH5004
A17A1CR753	152-0242-00		SEMICONV DEVICE:SILICON,225V,200MA	07263	FDH5004
A17A1CR781	152-0071-00		SEMICONV DEVICE:GERMANIUM,15V,40MA	15238	G865
A17A1DS249	150-0035-00		LAMP,GLOW:90V,0.3MA	53944	A1B-3
A17A1E237	119-0181-00		ARSR,ELEC SURGE:230V,GAS FILLED	74276	CG230L
A17A1E431	119-0181-00		ARSR,ELEC SURGE:230V,GAS FILLED	74276	CG230L
A17A1J61	131-0589-00		TERMINAL,PIN:0.46 L X 0.025 SQ	22526	48283-029
	-----		(QUANTITY OF 6)		
A17A1J62	175-2966-00		LEAD ASSY,ELEC:3,22 AWG,1.5 L	80009	175-2966-00
	-----		(QUANTITY OF 6)		
A17A1J67	131-0608-00		TERMINAL,PIN:0.365 L X 0.025 PH BRZ GOLD	22526	47357
	-----		(QUANTITY OF 2)		
A17A1J69	131-0993-00		BUS,CONDUCTOR:2 WIRE BLACK	00779	850100-01
A17A1Q138	151-0342-00		TRANSISTOR:SILICON,PNP	07263	S035928
A17A1Q139	151-0432-00		TRANSISTOR:SILICON,NPN	27014	ST07391D
A17A1Q205	151-0537-00		THYRISTOR:TRIAC,10A,400V	03508	SC146DX176
A17A1Q271	151-0432-00		TRANSISTOR:SILICON,NPN	27014	ST07391D

REPLACEABLE ELECTRICAL PARTS

A17A1 INVERTER (CONT)

Component No.	Tektronix Part No.	Serial/Model No. Eff Dscont	Name & Description	Mfr Code	Mfr Part Number
A17A1Q273	151-0435-00		TRANSISTOR: SILICON, PNP	04713	SPS8335
A17A1Q275	151-0432-00		TRANSISTOR: SILICON, NPN	27014	ST07391D
A17A1Q276	151-0482-00		TRANSISTOR: SILICON, PNP	80009	151-0482-00
A17A1Q575	151-0342-00		TRANSISTOR: SILICON, PNP	07263	S035928
A17A1Q663	151-0439-00		TRANSISTOR: SILICON, NPN	80009	151-0439-00
A17A1Q673	151-0342-00		TRANSISTOR: SILICON, PNP	07263	S035928
A17A1Q685	151-0136-00		TRANSISTOR: SILICON, NPN	02735	35495
A17A1Q751	151-0323-00		TRANSISTOR: SILICON, NPN, SEL FROM MJE521	04713	SJE916
A17A1Q759	151-0439-00		TRANSISTOR: SILICON, NPN	80009	151-0439-00
A17A1R68	311-1307-00		RES., VAR, NONWIR: 500 OHM, 0.50W	32997	3299W-R27-501
A17A1R103	308-0336-00		RES., FXD, WW: 7K OHM, 5%, 5W	12697	OBD
A17A1R104	308-0237-00		RES., FXD, WW: 8.2K OHM, 5%, 5W	14193	SA50
A17A1R113	315-0331-00		RES., FXD, CMPSN: 330 OHM, 5%, 0.25W	01121	CB3315
A17A1R126	315-0104-00		RES., FXD, CMPSN: 100K OHM, 5%, 0.25W	01121	CB1045
A17A1R127	315-0622-00		RES., FXD, CMPSN: 6.2K OHM, 5%, 0.25W	01121	CB6225
A17A1R151	305-0333-00		RES., FXD, CMPSN: 33K OHM, 5%, 2W	01121	HB3335
A17A1R175	315-0472-00		RES., FXD, CMPSN: 4.7K OHM, 5%, 0.25W	01121	CB4725
A17A1R177	315-0914-00		RES., FXD, CMPSN: 910K OHM, 5%, 0.25W	01121	CB9145
A17A1R178	321-0443-00		RES., FXD, FILM: 402K OHM, 1%, 0.125W	91637	MFF1816G40202F
A17A1R179	315-0474-00	B010100 B021324	RES., FXD, CMPSN: 470K OHM, 5%, 0.25W	01121	CB4745
A17A1R179	315-0274-00	B021325	RES., FXD, CMPSN: 270K OHM, 5%, 0.25W	01121	CB2745
A17A1R180	315-0101-00	XB021325	RES., FXD, CMPSN: 100 OHM, 5%, 0.25W	01121	CB1015
A17A1R221	315-0203-00		RES., FXD, CMPSN: 20K OHM, 5%, 0.25W	01121	CB2035
A17A1R249	301-0565-00		RES., FXD, CMPSN: 5.6M OHM, 5%, 0.50W	01121	EB5655
A17A1R260	305-0333-00		RES., FXD, CMPSN: 33K OHM, 5%, 2W	01121	HB3335
A17A1R275	321-0463-00		RES., FXD, FILM: 649K OHM, 1%, 0.125W	91637	MFF1816G64902F
A17A1R276	321-0423-00		RES., FXD, FILM: 249K OHM, 1%, 0.125W	91637	MFF1816G24902F
A17A1R277	315-0103-00		RES., FXD, CMPSN: 10K OHM, 5%, 0.25W	01121	CB1035
A17A1R281	315-0220-00		RES., FXD, CMPSN: 22 OHM, 5%, 0.25W	01121	CB2205
A17A1R283	315-0103-00		RES., FXD, CMPSN: 10K OHM, 5%, 0.25W	01121	CB1035
A17A1R373	321-0425-00	B010100 B021324	RES., FXD, FILM: 261K OHM, 1%, 0.125W	91637	MFF1816G26102F
A17A1R373	321-0431-00	B021325	RES., FXD, FILM: 301K OHM, 1%, 0.125W	91637	MFF1816G30102F
A17A1R376	315-0203-00		RES., FXD, CMPSN: 20K OHM, 5%, 0.25W	01121	CB2035
A17A1R383	315-0103-00		RES., FXD, CMPSN: 10K OHM, 5%, 0.25W	01121	CB1035
A17A1R384	315-0102-00		RES., FXD, CMPSN: 1K OHM, 5%, 0.25W	01121	CB1025
A17A1R471	315-0432-00		RES., FXD, CMPSN: 4.3K OHM, 5%, 0.25W	01121	CB4325
A17A1R472	315-0393-00		RES., FXD, CMPSN: 39K OHM, 5%, 0.25W	01121	CB3935
A17A1R473	315-0204-00		RES., FXD, CMPSN: 200K OHM, 5%, 0.25W	01121	CB2045
A17A1R474	315-0394-00		RES., FXD, CMPSN: 390K OHM, 5%, 0.25W	01121	CB3945
A17A1R475	315-0564-00		RES., FXD, CMPSN: 560K OHM, 5%, 0.25W	01121	CB5645
A17A1R477	321-0359-00		RES., FXD, FILM: 53.6K OHM, 1%, 0.125W	91637	MFF1816G53601F
A17A1R478	315-0104-00		RES., FXD, CMPSN: 100K OHM, 5%, 0.25W	01121	CB1045
A17A1R479	315-0104-00		RES., FXD, CMPSN: 100K OHM, 5%, 0.25W	01121	CB1045
A17A1R510	308-0079-00		RES., FXD, WW: 117 OHM, 5%, 5W	91637	RS5-K117R0J
A17A1R530	315-0101-00	B010100 B021324X	RES., FXD, CMPSN: 100 OHM, 5%, 0.25W	01121	CB1015
A17A1R570	315-0821-00		RES., FXD, CMPSN: 820 OHM, 5%, 0.25W	01121	CB8215
A17A1R571	315-0203-00		RES., FXD, CMPSN: 20K OHM, 5%, 0.25W	01121	CB2035
A17A1R573	321-0223-00		RES., FXD, FILM: 2.05K OHM, 1%, 0.125W	91637	MFF1816G20500F
A17A1R574	321-0202-00		RES., FXD, FILM: 1.24K OHM, 1%, 0.125W	91637	MFF1816G12400F
A17A1R575	321-0202-00		RES., FXD, FILM: 1.24K OHM, 1%, 0.125W	91637	MFF1816G12400F
A17A1R576	321-0246-00		RES., FXD, FILM: 3.57K OHM, 1%, 0.125W	91637	MFF1816G35700F
A17A1R577	321-0222-00		RES., FXD, FILM: 2K OHM, 1%, 0.125W	91637	MFF1816G20000F
A17A1R581	315-0220-00		RES., FXD, CMPSN: 22 OHM, 5%, 0.25W	01121	CB2205
A17A1R583	315-0103-00		RES., FXD, CMPSN: 10K OHM, 5%, 0.25W	01121	CB1035
A17A1R585	315-0103-00		RES., FXD, CMPSN: 10K OHM, 5%, 0.25W	01121	CB1035
A17A1R587	315-0823-00		RES., FXD, CMPSN: 82K OHM, 5%, 0.25W	01121	CB8235
A17A1R589	321-0193-00		RES., FXD, FILM: 1K OHM, 1%, 0.125W	91637	MFF1816G10000F

REPLACEABLE ELECTRICAL PARTS

A17A1 INVERTER (CONT)

Component No.	Tektronix Part No.	Serial/Model No. Eff Dscont	Name & Description	Mfr Code	Mfr Part Number
A17A1R630	307-0106-00		RES., FXD, CMPSN:4.7 OHM, 5%, 0.25W	01121	CB47G5
A17A1R631	308-0755-00		RES., FXD, WW:0.75 OHM, 5%, 2W	75042	BWH-R7500J
A17A1R633	308-0441-00		RES., FXD, WW:3 OHM, 5%, 3W	91637	CW2B-3R00J
A17A1R653	306-0331-00		RES., FXD, CMPSN:330 OHM, 10%, 2W	01121	HB3311
A17A1R674	315-0203-00		RES., FXD, CMPSN:20K OHM, 5%, 0.25W	01121	CB2035
A17A1R675	315-0511-00		RES., FXD, CMPSN:510 OHM, 5%, 0.25W	01121	CB5115
A17A1R679	321-0233-00		RES., FXD, FILM:2.61K OHM, 1%, 0.125W	91637	MFF1816G26100F
A17A1R683	321-0193-00		RES., FXD, FILM:1K OHM, 1%, 0.125W	91637	MFF1816G10000F
A17A1R684	315-0203-00	B010100 B021324	RES., FXD, CMPSN:20K OHM, 5%, 0.25W	01121	CB2035
A17A1R684	315-0153-00	B021325	RES., FXD, CMPSN:15K OHM, 5%, 0.25W	01121	CB1535
A17A1R686	315-0222-00	B010100 B021324	RES., FXD, CMPSN:2.2K OHM, 5%, 0.25W	01121	CB2225
A17A1R686	315-0912-00	B021325	RES., FXD, CMPSN:9.1K OHM, 5%, 0.25W	01121	CB9125
A17A1R729	307-0106-00		RES., FXD, CMPSN:4.7 OHM, 5%, 0.25W	01121	CB47G5
A17A1R731	308-0441-00		RES., FXD, WW:3 OHM, 5%, 3W	91637	CW2B-3R00J
A17A1R732	308-0755-00		RES., FXD, WW:0.75 OHM, 5%, 2W	75042	BWH-R7500J
A17A1R751	307-0009-00		RES., FXD, CMPSN:4.7 OHM, 10%, 2W	01121	GB47G1
A17A1R753	307-0009-00		RES., FXD, CMPSN:4.7 OHM, 10%, 2W	01121	GB47G1
A17A1R759	303-0122-00		RES., FXD, CMPSN:1.2K OHM, 5%, 1W	01121	GB1225
A17A1R763	315-0101-00		RES., FXD, CMPSN:100 OHM, 5%, 0.25W	01121	CB1015
A17A1R765	315-0101-00		RES., FXD, CMPSN:100 OHM, 5%, 0.25W	01121	CB1015
A17A1R780	315-0203-00	XB021325	RES., FXD, CMPSN:20K OHM, 5%, 0.25W	01121	CB2035
A17A1R783	315-0202-00		RES., FXD, CMPSN:2K OHM, 5%, 0.25W	01121	CB2025
A17A1R785	308-0497-00		RES., FXD, WW:105 OHM, 1%, 2.5W	91637	RS2B-A105R0F
A17A1RT331	307-0350-00		RES., THERMAL:7.5 OHM, 10%, 3.9%/DEG C	15454	75DJ7R5R0220SS
A17A1RT533	307-0350-00		RES., THERMAL:7.5 OHM, 10%, 3.9%/DEG C	15454	75DJ7R5R0220SS
A17A1T120	120-1354-00		XFMR, PWR, STPDN:TRIGGER, LF	80009	120-1354-00
A17A1T529	120-1352-00		TRANSFORMER, RF:TOROID	80009	120-1352-00
A17A1T645	120-1353-00		TRANSFORMER, RF:TOROID	80009	120-1353-00
A17A1T741	120-1119-01		TRANSFORMER, RF:BASE DRIVE	80009	120-1119-01
A17A1TP581	131-0608-00		TERMINAL, PIN:0.365 L X 0.025 PH BRZ GOLD	22526	47357
A17A1TP781	131-0608-00		TERMINAL, PIN:0.365 L X 0.025 PH BRZ GOLD	22526	47357
A17A1TP785	131-0608-00		TERMINAL, PIN:0.365 L X 0.025 PH BRZ GOLD	22526	47357
A17A1U277	156-0341-01		MICROCIRCUIT, DI:DUAL 2-INPUT OR DRIVER	80009	156-0341-01
A17A1U377	156-0094-01		MICROCIRCUIT, DI:DUAL 2-INP NAND DRVR, CHK	80009	156-0094-01
A17A1U379	156-0158-07		MICROCIRCUIT, LI:DUAL OPNL AMPL, SCREENED	01295	MC1458JG4
A17A1U479	156-1226-01		MICROCIRCUIT, LI:DUAL COMPTR, 14 DIP, SCRN	27014	LM319J/A+
A17A1U677	156-0933-01		MICROCIRCUIT, LI:RGLTR, PULSE WIDTH MOD, SCRN	34333	SG9976
A17A1VR176	153-0058-00		SEMICON DVC, SE:ZENER, SEL, 6.2V, 5%, 10MA	80009	153-0058-00

REPLACEABLE ELECTRICAL PARTS

Component No.	Tektronix Part No.	Serial/Model No. Eff Dscont	Name & Description	Mfr Code	Mfr Part Number
A17A2	670-6502-00	B010100 B021324	CKT BOARD ASSY:REGULATOR	80009	670-6502-00
A17A2	670-6502-01	B021325	CKT BOARD ASSY:REGULATOR	80009	670-6502-01
A17A2C105	281-0775-00		CAP.,FXD,CER DI:0.1UF,20%,50V	04222	SA205E104MAA
A17A2C106	281-0775-00		CAP.,FXD,CER DI:0.1UF,20%,50V	04222	SA205E104MAA
A17A2C111	283-0003-00		CAP.,FXD,CER DI:0.01UF,+80-20%,150V	91418	SP103Z151-4R9
A17A2C113	283-0067-00		CAP.,FXD,CER DI:0.001UF,10%,200V	59660	835-515-Z5D0102K
A17A2C131	290-0770-00		CAP.,FXD,ELCTLT:100UF,+50-10%,25V	56289	502D230
A17A2C141	290-0770-00		CAP.,FXD,ELCTLT:100UF,+50-10%,25V	56289	502D230
A17A2C151	283-0057-00		CAP.,FXD,CER DI:0.1UF,+80-20%,200V	56289	2C20Z5U104Z200B
A17A2C154	283-0003-00		CAP.,FXD,CER DI:0.01UF,+80-20%,150V	91418	SP103Z151-4R9
A17A2C163	281-0775-00		CAP.,FXD,CER DI:0.1UF,20%,50V	04222	SA205E104MAA
A17A2C175	283-0067-00		CAP.,FXD,CER DI:0.001UF,10%,200V	59660	835-515-Z5D0102K
A17A2C183	283-0067-00		CAP.,FXD,CER DI:0.001UF,10%,200V	59660	835-515-Z5D0102K
A17A2C184	283-0067-00		CAP.,FXD,CER DI:0.001UF,10%,200V	59660	835-515-Z5D0102K
A17A2C190	283-0178-00		CAP.,FXD,CER DI:0.1UF,+80-20%,100V	72982	8131N145651 104Z
A17A2C255	283-0177-00		CAP.,FXD,CER DI:1UF,+80-20%,25V	56289	273C5
A17A2C261	290-0798-00		CAP.,FXD,ELCTLT:180UF,+100-10%,40V	56289	672D187H04ODM5C
A17A2C293	283-0178-00		CAP.,FXD,CER DI:0.1UF,+80-20%,100V	72982	8131N145651 104Z
A17A2C331	283-0057-00		CAP.,FXD,CER DI:0.1UF,+80-20%,200V	56289	2C20Z5U104Z200B
A17A2C383	281-0775-00		CAP.,FXD,CER DI:0.1UF,20%,50V	04222	SA205E104MAA
A17A2C392	281-0775-00		CAP.,FXD,CER DI:0.1UF,20%,50V	04222	SA205E104MAA
A17A2C423	283-0003-00		CAP.,FXD,CER DI:0.01UF,+80-20%,150V	91418	SP103Z151-4R9
A17A2C433	283-0028-00		CAP.,FXD,CER DI:0.0022UF,20%,50V	56289	19C606
A17A2C451	283-0028-00		CAP.,FXD,CER DI:0.0022UF,20%,50V	56289	19C606
A17A2C461	290-0798-00		CAP.,FXD,ELCTLT:180UF,+100-10%,40V	56289	672D187H04ODM5C
A17A2C521	290-0798-00		CAP.,FXD,ELCTLT:180UF,+100-10%,40V	56289	672D187H04ODM5C
A17A2C533	283-0028-00		CAP.,FXD,CER DI:0.0022UF,20%,50V	56289	19C606
A17A2C553	283-0028-00		CAP.,FXD,CER DI:0.0022UF,20%,50V	56289	19C606
A17A2C563	290-0773-00		CAP.,FXD,ELCTLT:1000UF,+50-10%,10V	0000L	ECE-B10Z1000
A17A2C581	290-0751-00		CAP.,FXD,ELCTLT:2200UF,+50-10%,16V	56289	D76245
A17A2C585	290-0800-00		CAP.,FXD,ELCTLT:250UF,+100-10%,20V	56289	672D257H0200M5C
A17A2C621	290-0816-00		CAP.,FXD,ELCTLT:400UF,+75-10%,50V	56289	39D985
A17A2C671	283-0057-00	B010100 B021324X	CAP.,FXD,CER DI:0.1UF,+80-20%,200V	56289	2C20Z5U104Z200B
A17A2C720	281-0775-00		CAP.,FXD,CER DI:0.1UF,20%,50V	04222	SA205E104MAA
A17A2C789	290-0751-00		CAP.,FXD,ELCTLT:2200UF,+50-10%,16V	56289	D76245
A17A2C796	281-0775-00		CAP.,FXD,CER DI:0.1UF,20%,50V	04222	SA205E104MAA
A17A2CR123	152-0066-00		SEMICONV DEVICE:SILICON,400V,750MA	14433	LG4016
A17A2CR124	152-0066-00		SEMICONV DEVICE:SILICON,400V,750MA	14433	LG4016
A17A2CR141	152-0141-02		SEMICONV DEVICE:SILICON,30V,150MA	01295	1N4152R
A17A2CR171	152-0661-00		SEMICONV DEVICE:RECT,SI,600V,3A,FAST	04713	MR856
A17A2CR172	152-0661-00		SEMICONV DEVICE:RECT,SI,600V,3A,FAST	04713	MR856
A17A2CR173	152-0784-00		SEMICONV DEVICE:RECT,SI,FAST RCVY,200V,5.0	04713	SR3688
A17A2CR181	152-0661-00		SEMICONV DEVICE:RECT,SI,600V,3A,FAST	04713	MR856
A17A2CR182	152-0661-00		SEMICONV DEVICE:RECT,SI,600V,3A,FAST	04713	MR856
A17A2CR213	152-0175-00		SEMICONV DEVICE:ZENER,0.4W,5.6V,5%	04713	SZG35008
A17A2CR231	152-0066-00		SEMICONV DEVICE:SILICON,400V,750MA	14433	LG4016
A17A2CR236	152-0141-02		SEMICONV DEVICE:SILICON,30V,150MA	01295	1N4152R
A17A2CR237	152-0141-02		SEMICONV DEVICE:SILICON,30V,150MA	01295	1N4152R
A17A2CR238	152-0141-02		SEMICONV DEVICE:SILICON,30V,150MA	01295	1N4152R
A17A2CR271	152-0784-00		SEMICONV DEVICE:RECT,SI,FAST RCVY,200V,5.0	04713	SR3688
A17A2CR341	152-0141-02		SEMICONV DEVICE:SILICON,30V,150MA	01295	1N4152R
A17A2CR519	152-0066-00		SEMICONV DEVICE:SILICON,400V,750MA	14433	LG4016
A17A2CR641	152-0141-02		SEMICONV DEVICE:SILICON,30V,150MA	01295	1N4152R
A17A2CR642	152-0141-02		SEMICONV DEVICE:SILICON,30V,150MA	01295	1N4152R
A17A2L215	108-0317-00		COIL,RF:FIXED,15UH	32159	71501M
A17A2L261	108-1017-00		COIL,RF:FXD,1MH	80009	108-1017-00
A17A2L291	108-1068-00		COIL,RF:FIXED,700UH	80009	108-1068-00

REPLACEABLE ELECTRICAL PARTS

A17A2 REGULATOR (CONT)

Component No.	Tektronix Part No.	Serial/Model No. Eff Dscont	Name & Description	Mfr Code	Mfr Part Number
A17A2L361	108-0860-00		COIL, RF: FIXED, 605UH	80009	108-0860-00
A17A2L391	108-1067-00		COIL, RF: FIXED, 52MH	80009	108-1067-00
A17A2L565	108-0935-00		COIL, RF: FIXED, 2.4UH	80009	108-0935-00
A17A2Q115	151-0188-00		TRANSISTOR: SILICON, PNP	04713	SPS6868K
A17A2Q251	151-0188-00		TRANSISTOR: SILICON, PNP	04713	SPS6868K
A17A2Q252	151-1005-00		TRANSISTOR: SILICON, JFE, N-CHANNEL	80009	151-1005-00
A17A2Q253	151-0188-00		TRANSISTOR: SILICON, PNP	04713	SPS6868K
A17A2Q254	151-0188-00		TRANSISTOR: SILICON, PNP	04713	SPS6868K
A17A2Q344	151-1005-00		TRANSISTOR: SILICON, JFE, N-CHANNEL	80009	151-1005-00
A17A2Q441	151-0190-00		TRANSISTOR: SILICON, NPN	07263	S032677
A17A2Q442	151-0190-00		TRANSISTOR: SILICON, NPN	07263	S032677
A17A2Q443	151-0190-00		TRANSISTOR: SILICON, NPN	07263	S032677
A17A2Q541	151-0190-00		TRANSISTOR: SILICON, NPN	07263	S032677
A17A2Q631	151-0350-00		TRANSISTOR: SILICON, PNP	04713	SPS6700
A17A2Q632	151-0350-00		TRANSISTOR: SILICON, PNP	04713	SPS6700
A17A2Q633	151-0350-00		TRANSISTOR: SILICON, PNP	04713	SPS6700
A17A2Q651	151-1005-00		TRANSISTOR: SILICON, JFE, N-CHANNEL	80009	151-1005-00
A17A2Q655	151-0188-00		TRANSISTOR: SILICON, PNP	04713	SPS6868K
A17A2Q731	151-0432-00		TRANSISTOR: SILICON, NPN	27014	ST07391D
A17A2Q775	151-0190-00		TRANSISTOR: SILICON, NPN	07263	S032677
A17A2Q781	151-0188-00		TRANSISTOR: SILICON, PNP	04713	SPS6868K
A17A2R112	315-0511-00		RES., FXD, CMPSN: 510 OHM, 5%, 0.25W	01121	CB5115
A17A2R114	315-0470-00		RES., FXD, CMPSN: 47 OHM, 5%, 0.25W	01121	CB4705
A17A2R116	315-0221-00		RES., FXD, CMPSN: 220 OHM, 5%, 0.25W	01121	CB2215
A17A2R121	301-0152-00		RES., FXD, CMPSN: 1.5K OHM, 5%, 0.50W	01121	EB1525
A17A2R122	315-0511-00		RES., FXD, CMPSN: 510 OHM, 5%, 0.25W	01121	CB5115
A17A2R124	315-0101-00		RES., FXD, CMPSN: 100 OHM, 5%, 0.25W	01121	CB1015
A17A2R125	308-0590-00		RES., FXD, WW: 0.25 OHM, 5%, 3W	91637	RS2B-ER2500J
A17A2R143	315-0102-00		RES., FXD, CMPSN: 1K OHM, 5%, 0.25W	01121	CB1025
A17A2R144	315-0202-00		RES., FXD, CMPSN: 2K OHM, 5%, 0.25W	01121	CB2025
A17A2R152	315-0511-00		RES., FXD, CMPSN: 510 OHM, 5%, 0.25W	01121	CB5115
A17A2R153	315-0101-00		RES., FXD, CMPSN: 100 OHM, 5%, 0.25W	01121	CB1015
A17A2R155	315-0221-00		RES., FXD, CMPSN: 220 OHM, 5%, 0.25W	01121	CB2215
A17A2R185	315-0100-00		RES., FXD, CMPSN: 10 OHM, 5%, 0.25W	01121	CB1005
A17A2R186	315-0100-00		RES., FXD, CMPSN: 10 OHM, 5%, 0.25W	01121	CB1005
A17A2R190	307-0004-00		RES., FXD, CMPSN: 3.9 OHM, 5%, 1W	23223	C10L-120000K
A17A2R216	315-0101-00		RES., FXD, CMPSN: 100 OHM, 5%, 0.25W	01121	CB1015
A17A2R234	321-1296-03		RES., FXD, FILM: 12K OHM, 0.25%, 0.125W	91637	MFF1816D12001C
A17A2R235	315-0362-00		RES., FXD, CMPSN: 3.6K OHM, 5%, 0.25W	01121	CB3625
A17A2R240	315-0101-00		RES., FXD, CMPSN: 100 OHM, 5%, 0.25W	01121	CB1015
A17A2R241	321-1609-03		RES., FXD, FILM: 2.02K OHM, 0.25%, 0.125W	24546	NC55C2021C
A17A2R242	321-0177-00		RES., FXD, FILM: 681 OHM, 1%, 0.125W	91637	MFF1816G681R0F
A17A2R243	321-1296-03		RES., FXD, FILM: 12K OHM, 0.25%, 0.125W	91637	MFF1816D12001C
A17A2R244	321-0240-01		RES., FXD, FILM: 3.09K OHM, 0.5%, 0.125W	91637	MFF1816G30900D
A17A2R245	315-0202-00		RES., FXD, CMPSN: 2K OHM, 5%, 0.25W	01121	CB2025
A17A2R253	315-0201-00		RES., FXD, CMPSN: 200 OHM, 5%, 0.25W	01121	CB2015
A17A2R293	307-0004-00		RES., FXD, CMPSN: 3.9 OHM, 5%, 1W	23223	C10L-120000K
A17A2R310	303-0751-00		RES., FXD, CMPSN: 750 OHM, 5%, 1W	01121	GB7515
A17A2R332	321-0326-00		RES., FXD, FILM: 24.3K OHM, 1%, 0.125W	91637	MFF1816G24301F
A17A2R334	321-1701-04		RES., FXD, FILM: 5.22K OHM, 0.1%, 0.125W	91637	MFF1816D52200B
A17A2R335	321-1296-03		RES., FXD, FILM: 12K OHM, 0.25%, 0.125W	91637	MFF1816D12001C
A17A2R342	315-0272-00		RES., FXD, CMPSN: 2.7K OHM, 5%, 0.25W	01121	CB2725
A17A2R343	315-0201-00		RES., FXD, CMPSN: 200 OHM, 5%, 0.25W	01121	CB2015
A17A2R351	321-1296-03		RES., FXD, FILM: 12K OHM, 0.25%, 0.125W	91637	MFF1816D12001C
A17A2R352	321-0159-00		RES., FXD, FILM: 442 OHM, 1%, 0.125W	91637	MFF1816G442R0F
A17A2R353	321-1701-04		RES., FXD, FILM: 5.22K OHM, 0.1%, 0.125W	91637	MFF1816D52200B
A17A2R355	315-0203-00		RES., FXD, CMPSN: 20K OHM, 5%, 0.25W	01121	CB2035

REPLACEABLE ELECTRICAL PARTS

A17A2 REGULATOR (CONT)

Component No.	Tektronix Part No.	Serial/Model No. Eff Dscont	Name & Description	Mfr Code	Mfr Part Number
A17A2R382	301-0102-00		RES., FXD, CMPSN:1K OHM, 5%, 0.50W	01121	EB1025
A17A2R418	315-0101-00		RES., FXD, CMPSN:100 OHM, 5%, 0.25W	01121	CB1015
A17A2R421	321-1701-04		RES., FXD, FILM:5.22K OHM, 0.1%, 0.125W	91637	MFF1816D52200B
A17A2R422	321-1296-03		RES., FXD, FILM:12K OHM, 0.25%, 0.125W	91637	MFF1816D12001C
A17A2R432	315-0202-00		RES., FXD, CMPSN:2K OHM, 5%, 0.25W	01121	CB2025
A17A2R451	315-0472-00		RES., FXD, CMPSN:4.7K OHM, 5%, 0.25W	01121	CB4725
A17A2R518	315-0301-00		RES., FXD, CMPSN:300 OHM, 5%, 0.25W	01121	CB3015
A17A2R531	315-0202-00		RES., FXD, CMPSN:2K OHM, 5%, 0.25W	01121	CB2025
A17A2R532	315-0202-00		RES., FXD, CMPSN:2K OHM, 5%, 0.25W	01121	CB2025
A17A2R535	315-0202-00		RES., FXD, CMPSN:2K OHM, 5%, 0.25W	01121	CB2025
A17A2R545	308-0075-00		RES., FXD, WW:100 OHM, 5%, 3W	91637	CW2B-100R0J-T/R
A17A2R546	321-0325-00		RES., FXD, FILM:23.7K OHM, 1%, 0.125W	91637	MFF1816G23701F
A17A2R547	321-0159-00		RES., FXD, FILM:442 OHM, 1%, 0.125W	91637	MFF1816G442R0F
A17A2R548	315-0273-00		RES., FXD, CMPSN:27K OHM, 5%, 0.25W	01121	CB2735
A17A2R551	315-0752-00		RES., FXD, CMPSN:7.5K OHM, 5%, 0.25W	01121	CB7525
A17A2R552	315-0752-00		RES., FXD, CMPSN:7.5K OHM, 5%, 0.25W	01121	CB7525
A17A2R554	321-0151-00		RES., FXD, FILM:365 OHM, 1%, 0.125W	91637	MFF1816G365R0F
A17A2R555	321-0816-03		RES., FXD, FILM:5K OHM, 0.25%, 0.125W	91637	MFF1816D50000C
A17A2R557	315-0510-00		RES., FXD, CMPSN:51 OHM, 5%, 0.25W	01121	CB5105
A17A2R583	308-0701-00		RES., FXD, WW:0.12 OHM, 5%, 2W	75042	BWH-R1200J
A17A2R619	308-0568-00		RES., FXD, WW:35 OHM, 5%, 5W	91637	RS5-K35R00J
A17A2R621	308-0643-00		RES., FXD, WW:0.1 OHM, 3%, 3W	91637	RS2B-ER1000H
A17A2R643	315-0201-00		RES., FXD, CMPSN:200 OHM, 5%, 0.25W	01121	CB2015
A17A2R661	303-0510-00		RES., FXD, CMPSN:51 OHM, 5%, 1W	01121	GB5105
A17A2R665	315-0202-00		RES., FXD, CMPSN:2K OHM, 5%, 0.25W	01121	CB2025
A17A2R693	315-0511-00		RES., FXD, CMPSN:510 OHM, 5%, 0.25W	01121	CB5115
A17A2R695	308-0757-00		RES., FXD, WW:0.025 OHM, 3%, 5W	91637	LVR5-GR0250H
A17A2R732	315-0202-00		RES., FXD, CMPSN:2K OHM, 5%, 0.25W	01121	CB2025
A17A2R756	315-0202-00		RES., FXD, CMPSN:2K OHM, 5%, 0.25W	01121	CB2025
A17A2R762	308-0643-00		RES., FXD, WW:0.1 OHM, 3%, 3W	91637	RS2B-ER1000H
A17A2R793	315-0203-00		RES., FXD, CMPSN:20K OHM, 5%, 0.25W	01121	CB2035
A17A2R795	315-0101-00		RES., FXD, CMPSN:100 OHM, 5%, 0.25W	01121	CB1015
A17A2T525	120-1355-00		XFMR, PWR, STPDN:HF CONVERTER	80009	120-1355-00
A17A2U431	156-0158-07		MICROCIRCUIT, LI:DUAL OPNL AMPL, SCREENED	01295	MC1458JG4
A17A2U451	156-0158-07		MICROCIRCUIT, LI:DUAL OPNL AMPL, SCREENED	01295	MC1458JG4
A17A2VR142	152-0508-00		SEMICOND DEVICE:ZENER, 0.4W, 12.6V, 5%	80009	152-0508-00
A17A2VR212	152-0395-00		SEMICOND DEVICE:ZENER, 0.4W, 4.3V, 5%	14552	TD332317
A17A2VR555	152-0395-00		SEMICOND DEVICE:ZENER, 0.4W, 4.3V, 5%	14552	TD332317

REPLACEABLE ELECTRICAL PARTS

Component No.	Tektronix Part No.	Serial/Model No. Eff Dscont	Name & Description	Mfr Code	Mfr Part Number
CHASSIS PARTS					
A5001	119-0420-00		FILTER, RFI: 6A, 250VAC, 400HZ	02777	F-11935-6
A9001	263-0073-01	B010100 B010169	SWITCH, ROTARY: OPTICAL, CURSOR	80009	263-0073-01
A9001	263-0073-02	B010170 B010444	SWITCH, ROTARY: OPTICAL, CURSOR	80009	263-0073-02
A9001	263-0073-03	B010445	SWITCH, ROTARY: OPTICAL, CURSOR	80009	263-0073-03
A9002	263-0073-01	B010100 B010169	SWITCH, ROTARY: OPTICAL, CURSOR	80009	263-0073-01
A9002	263-0073-02	B010170 B010144	SWITCH, ROTARY: OPTICAL, CURSOR	80009	263-0073-02
A9002	263-0073-03	B010445	SWITCH, ROTARY: OPTICAL, CURSOR	80009	263-0073-03
B1003	119-0721-00		FAN, VENTILATING: 75 CFM, 7W, 115VAC, 50/60HZ (OPTION 40, 41 ONLY)	82877	027119
B1004	119-0721-00		FAN, VENTILATING: 75 CFM, 7W, 115VAC, 50/60HZ (OPTION 40, 41 ONLY)	82877	027119
CR591	152-0066-00		SEMICONV DEVICE: SILICON, 400V, 750MA	14433	LG4016
CR1005	152-0518-00		SEMICONV DEVICE: RECT, SI, 50V, 27A	83003	K019
CR1006	152-0518-00		SEMICONV DEVICE: RECT, SI, 50V, 27A	83003	K019
F5001	159-0149-00		FUSE, CARTRIDGE: 4A, 250V, SLOW-BLOW (4114 ONLY)	71400	MDA 4 AMP
F5001	159-0023-00		FUSE, CARTRIDGE: 3AG, 2A, 250V, 5SEC (OPTION A1, A2, A3, A4)	71400	MDX2
L1002	119-0971-00		COIL, TUBE DEFL:	80009	119-0971-00
LS1001	119-0962-00		LOUDSPEAKER, PM: 8 OHM, 3W, 2.047 DIA	54473	EAS-5PH04SC
Q1001	151-0623-00		TRANSISTOR: SILICON, NPN	01295	T1P52
Q1002	151-0373-00		TRANSISTOR: SILICON, PNP	80009	151-0373-00
Q1003	151-0415-00		TRANSISTOR: SILICON, NPN	04713	SJE419
R5001	311-2114-00		RES., VAR, NONWIR: PNL, 10K OHM, 20%, 0.25W	01121	72J4G040R103M
S3001	260-2058-00		SWITCH, PUSH: DPDT, 1A, 25VDC	31918	601003
S3002	260-1970-00		SWITCH, PUSH: 0.4VA, 20V MAXIMUM	09353	8125J81E
S3003	260-1970-00		SWITCH, PUSH: 0.4VA, 20V MAXIMUM	09353	8125J81E
T1001	120-1097-00		XFMR, PWR, SDN&SU:	80009	120-1097-00
U1001	148-1005-00		RELAY, SOL STATE: 250VAC, 10A CONT, 12VDC	90484	C1-120-PC-240
U1002	156-0277-00		MICROCIRCUIT, LI: VOLTAGE REGULATOR	07263	MICROA7805UC
V5001	154-0785-52		ELECTRON TUBE: CRT	80009	154-0785-52

NEED
1
(Front)

Section 7

INTERCONNECT AND BLOCK DIAGRAMS

INTRODUCTION

This section lists the interconnect and block diagrams for the 4114. Some of these diagrams are included in the Theory of Operation section in Volume 1; they are repeated here for ease of referencing.

INTERCONNECT DIAGRAMS

- Power Supply Interconnect
- Motherboard Interconnect
- Motherboard Extender Interconnect
- Pedestal to Display and Power Display Interconnect
- Display Controller Interconnect
- RAM Controller Interconnect
- CRT Interconnect

BLOCK DIAGRAMS

- Simplified Processor Board
- Processor
- Programmable Communications Interface
- Keyboard
- RAM/ROM
- High Efficiency Power Supply
- Power Supply Inverter
- Power Supply Regulator
- Power Supply Pulse Width Modulator
- Display Control Circuitry
- Display Controller Board
- Simplified Display Controller
- Vector Generator
- Simplified Vector Generator
- Display Module

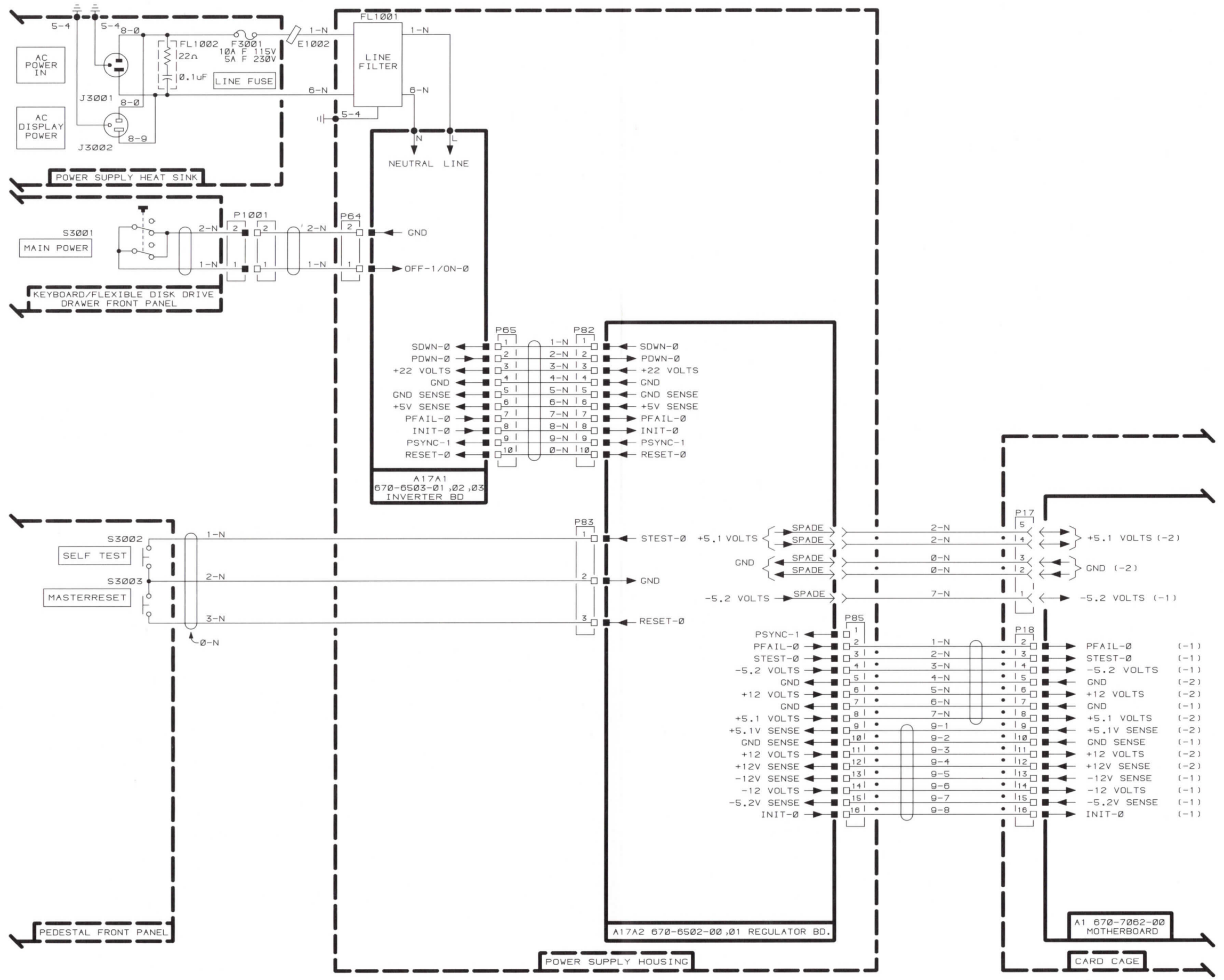

POWER SUPPLY INTERCONNECT

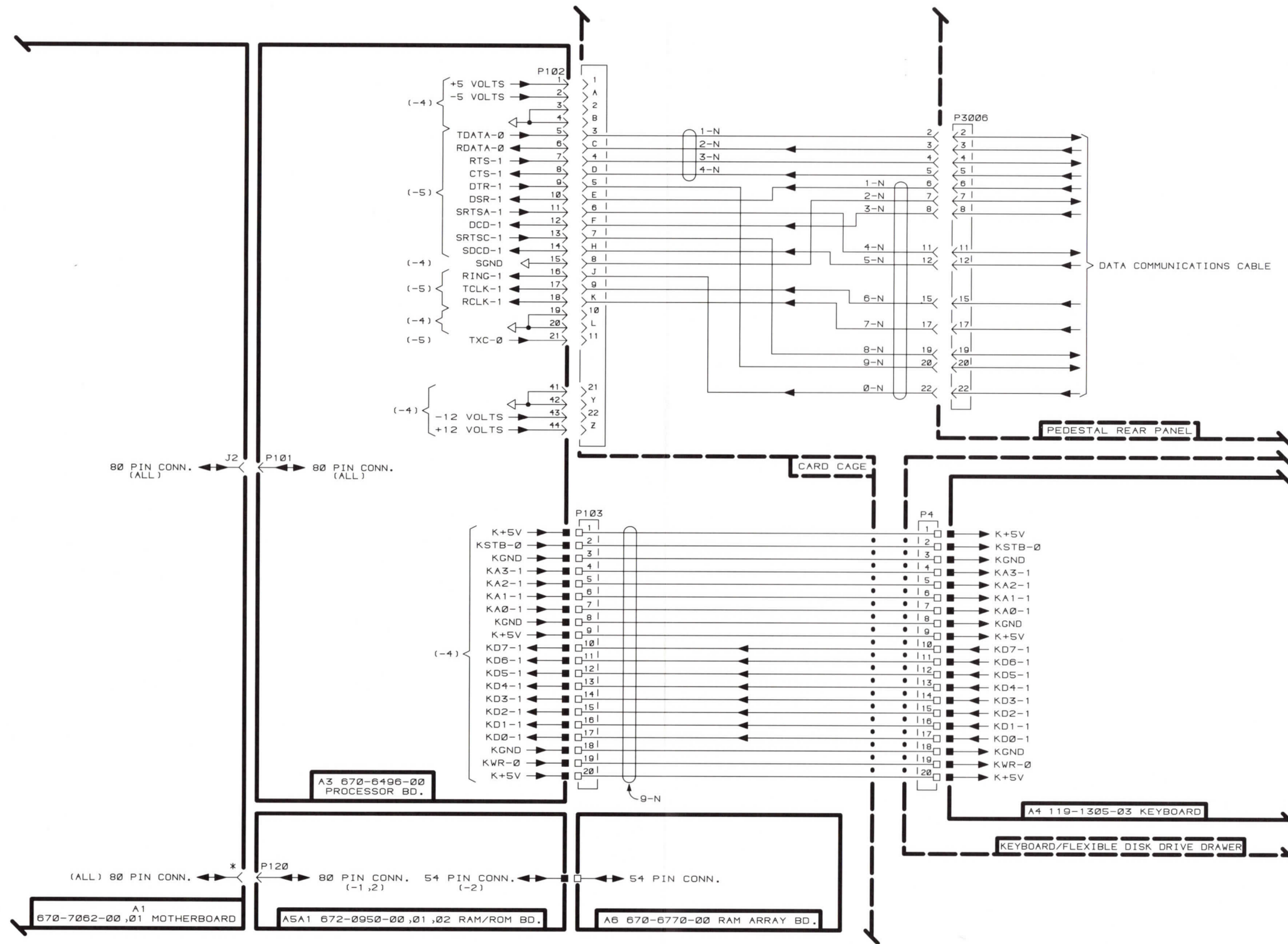

*J3 WHEN DISK CONTROLLER BOARD IS PRESENT.
 J6 OF A2 670-7063-00,01 MOTHERBOARD EXTENDER
 WHEN BOTH DISK CONTROLLER & 3PPI BOARDS ARE
 PRESENT.

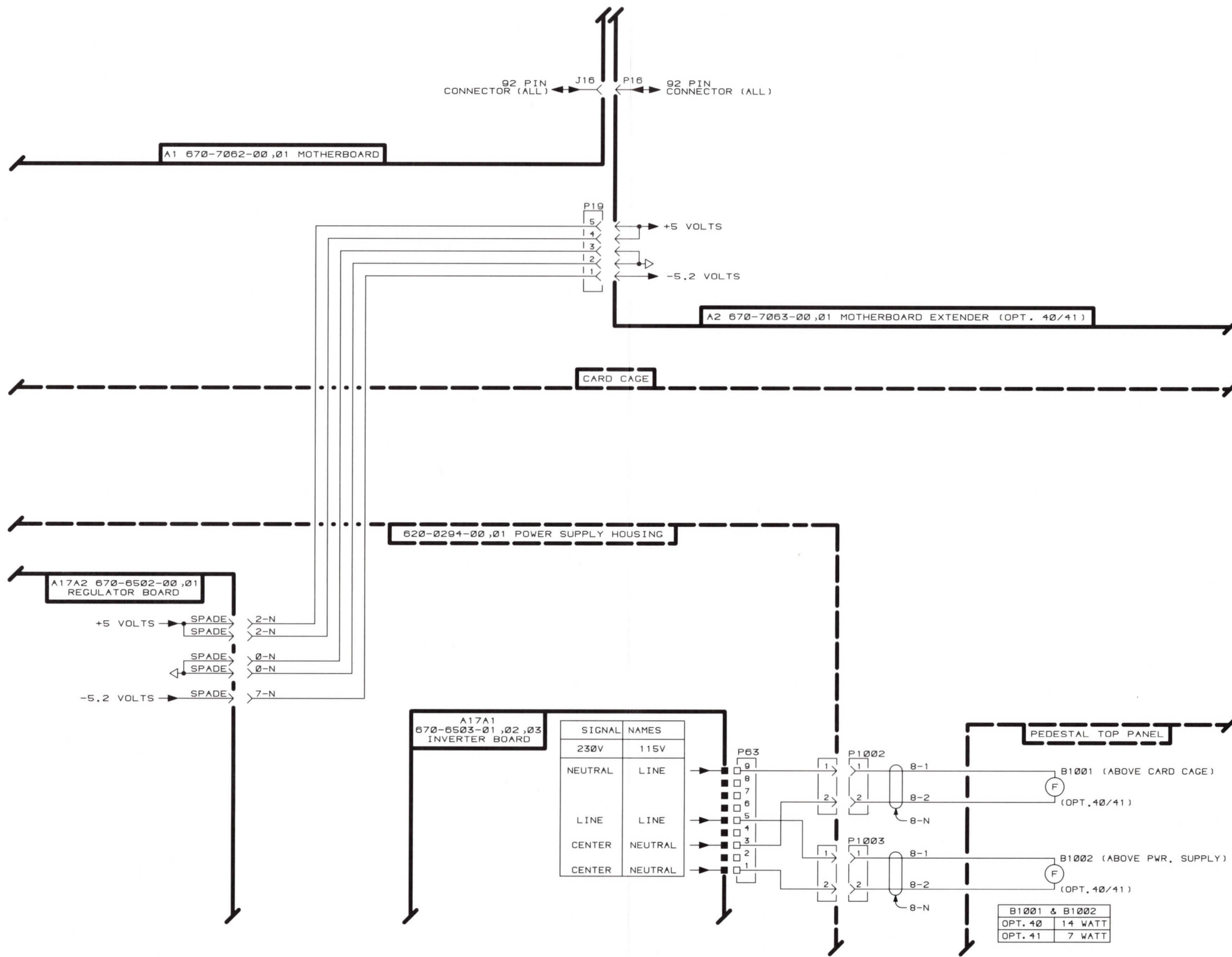

4114 OPT. 40/41

REV, JUN 1982
3818-4

MOTHERBOARD EXTENDER INTERCONNECT

(1 OF 1)

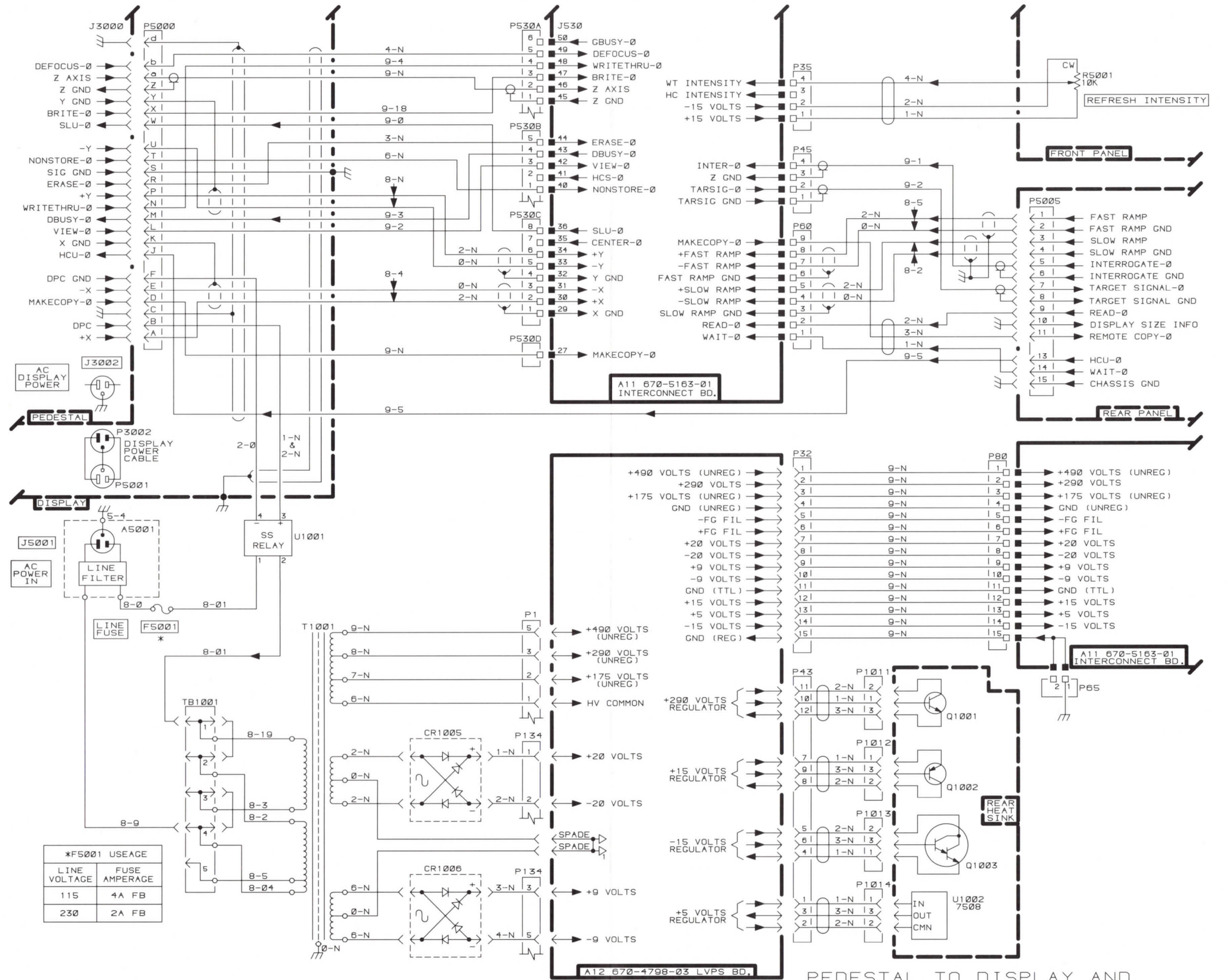

*F5001 USAGE

LINE VOLTAGE	FUSE AMPERAGE
115	4A FB
230	2A FB

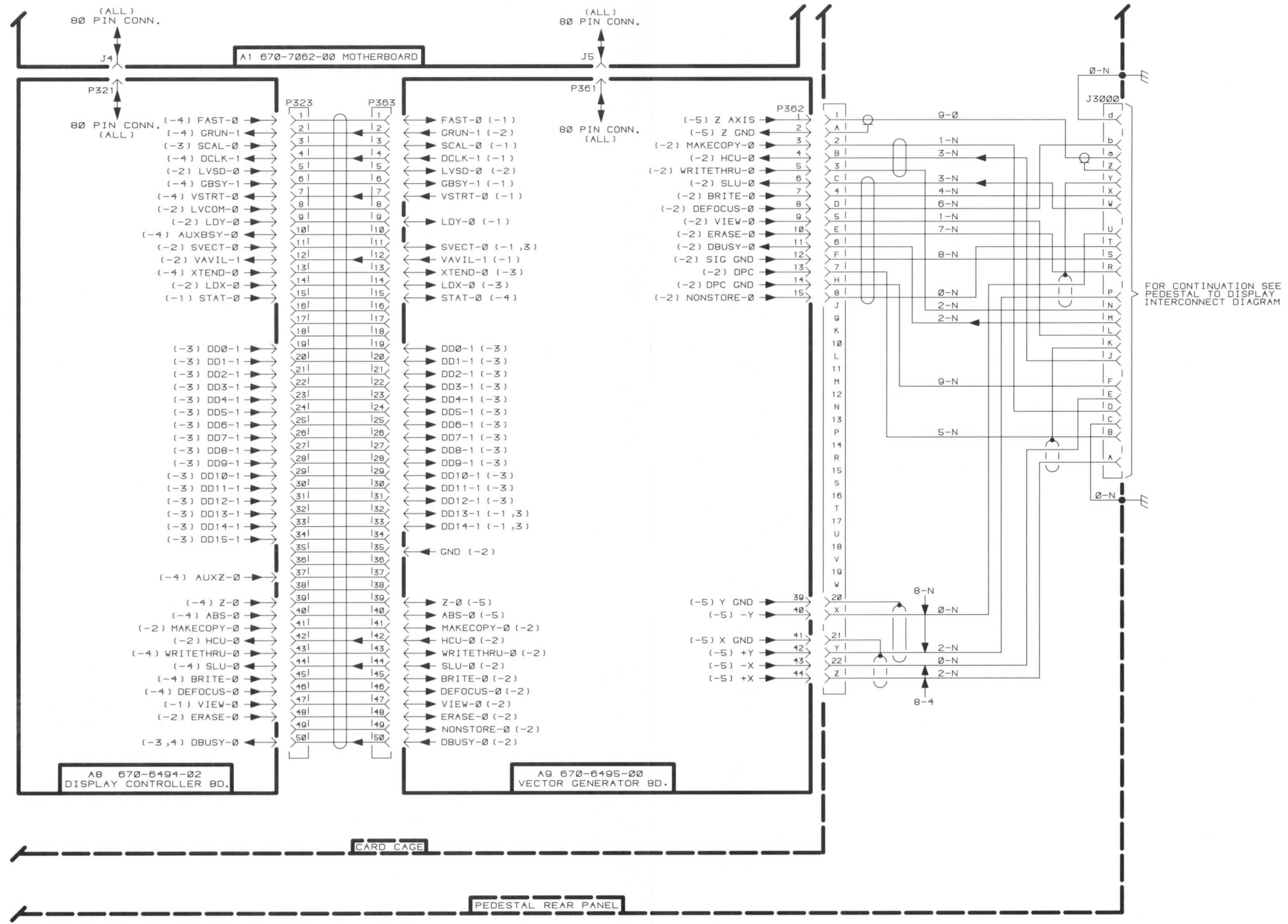

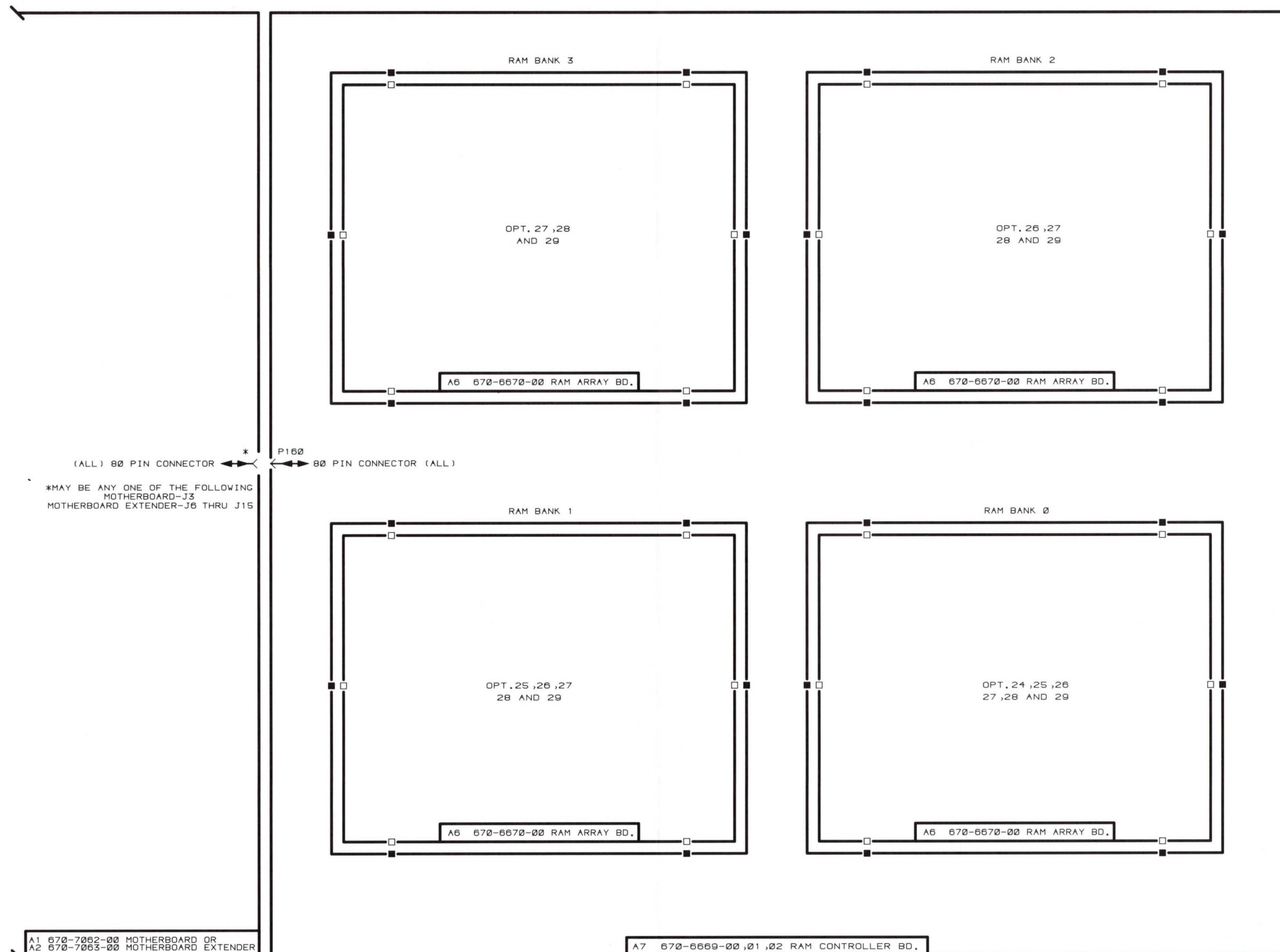

4114 OPT. 24 thru 29

REV, AUG 1981
3818-16

RAM CONTROLLER INTERCONNECT
(1 OF 1)

RAM CONTROLLER
INTERCONNECT

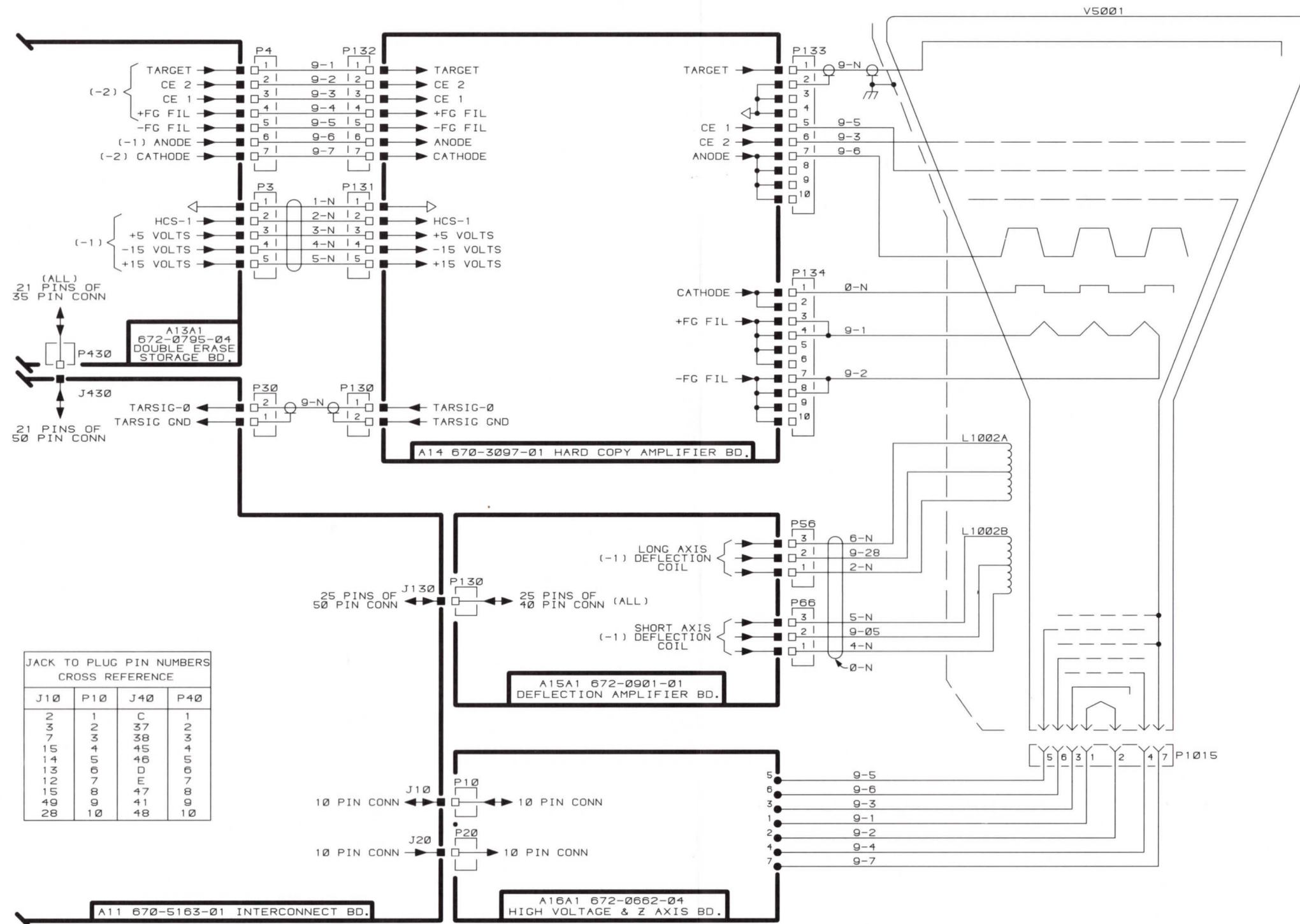

JACK TO PLUG PIN NUMBERS
CROSS REFERENCE

J10	P10	J40	P40
2	1	C	1
3	2	37	2
7	3	38	3
15	4	45	4
14	5	46	5
13	6	D	6
12	7	E	7
15	8	47	8
49	9	41	9
28	10	48	10

4114

REV, MAY 1982
3818-34

CRT INTERCONNECT (1 OF 1)

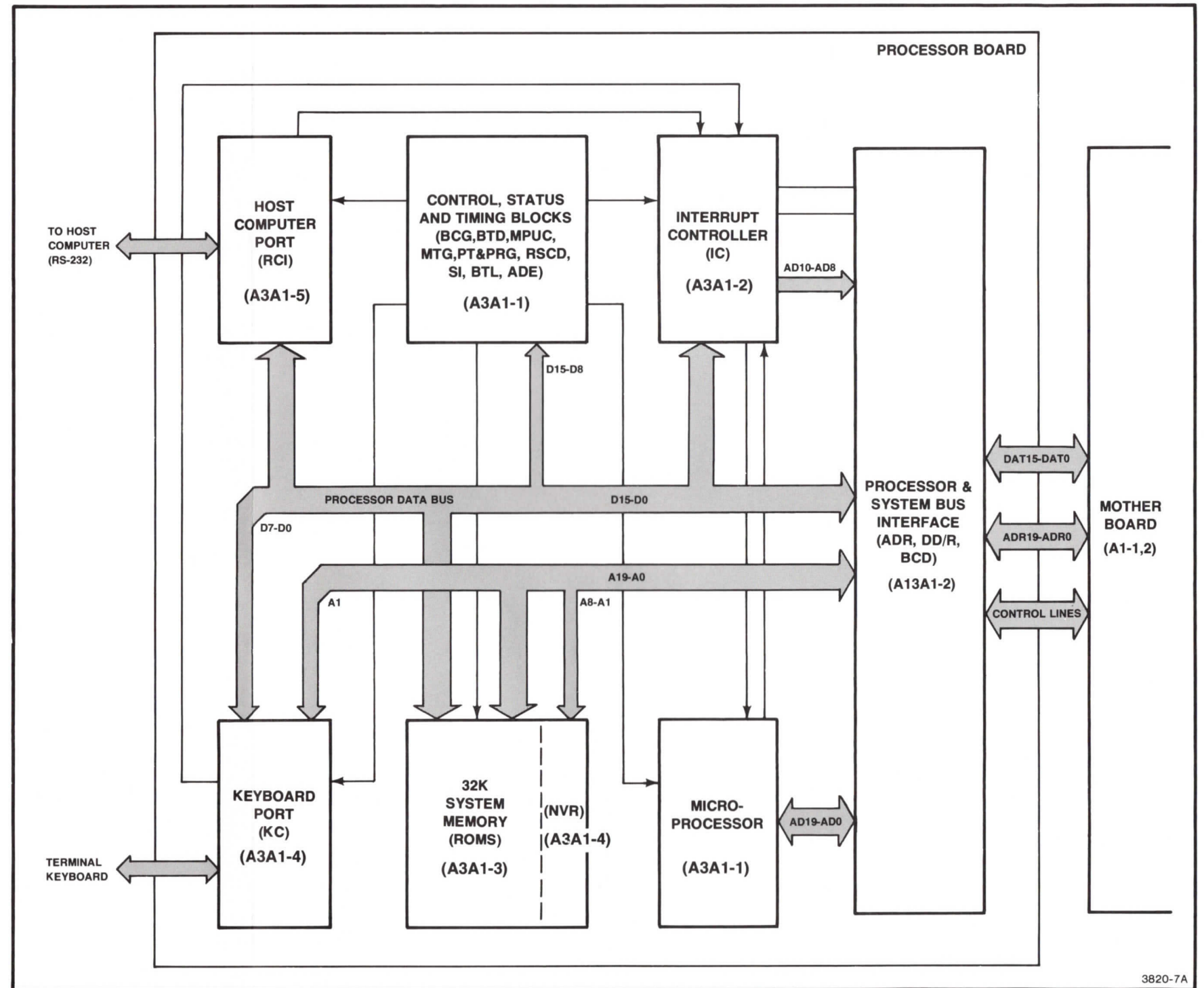

Simplified Processor Block Diagram

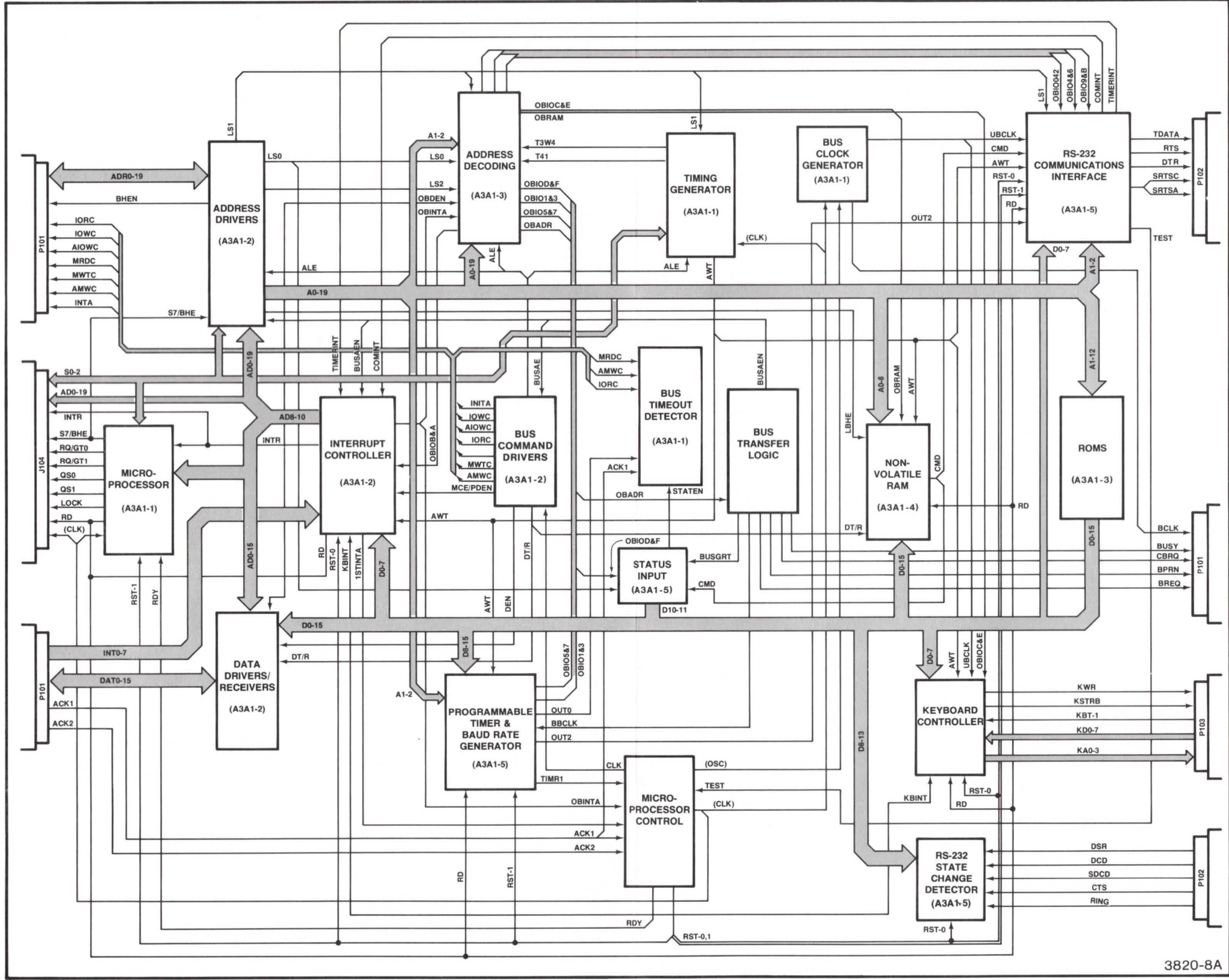

3820-8A

Processor Block Diagram

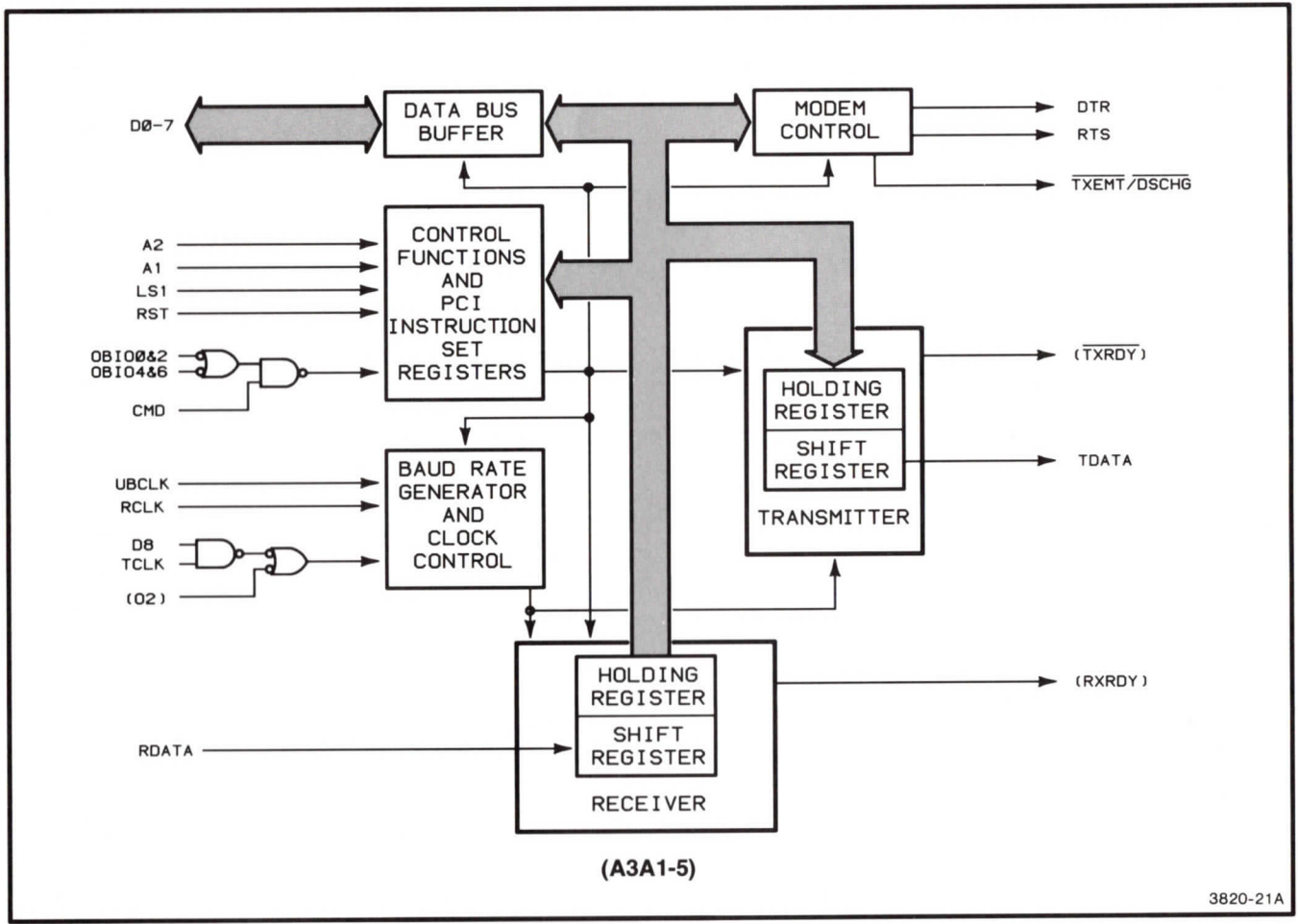

(A3A1-5)

3820-21A

Programmable Communications Interface

PROGRAMMABLE COMMUNICATIONS INTERFACE

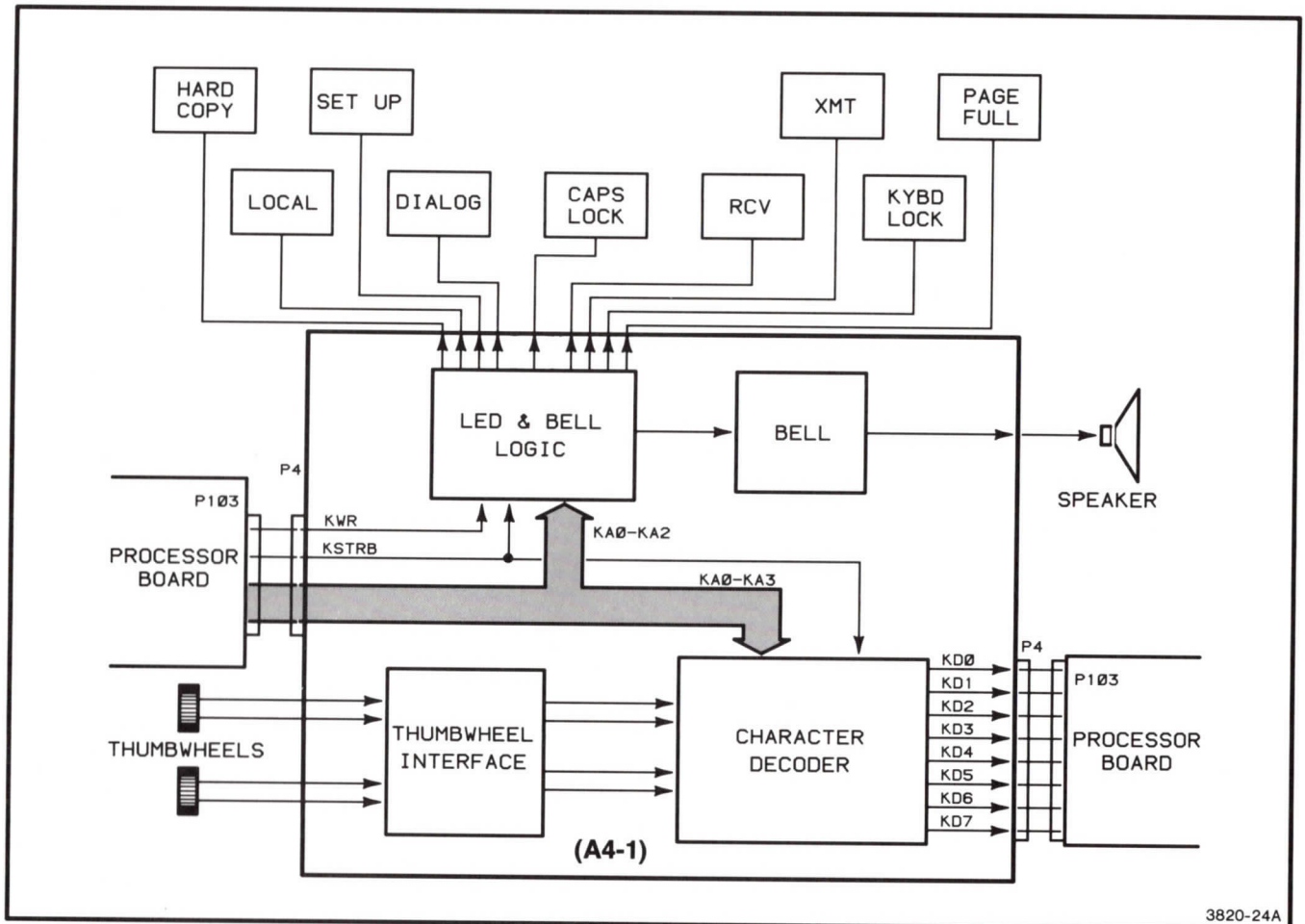

3820-24A

Keyboard Block Diagram

KEYBOARD
BLOCK DIAGRAM

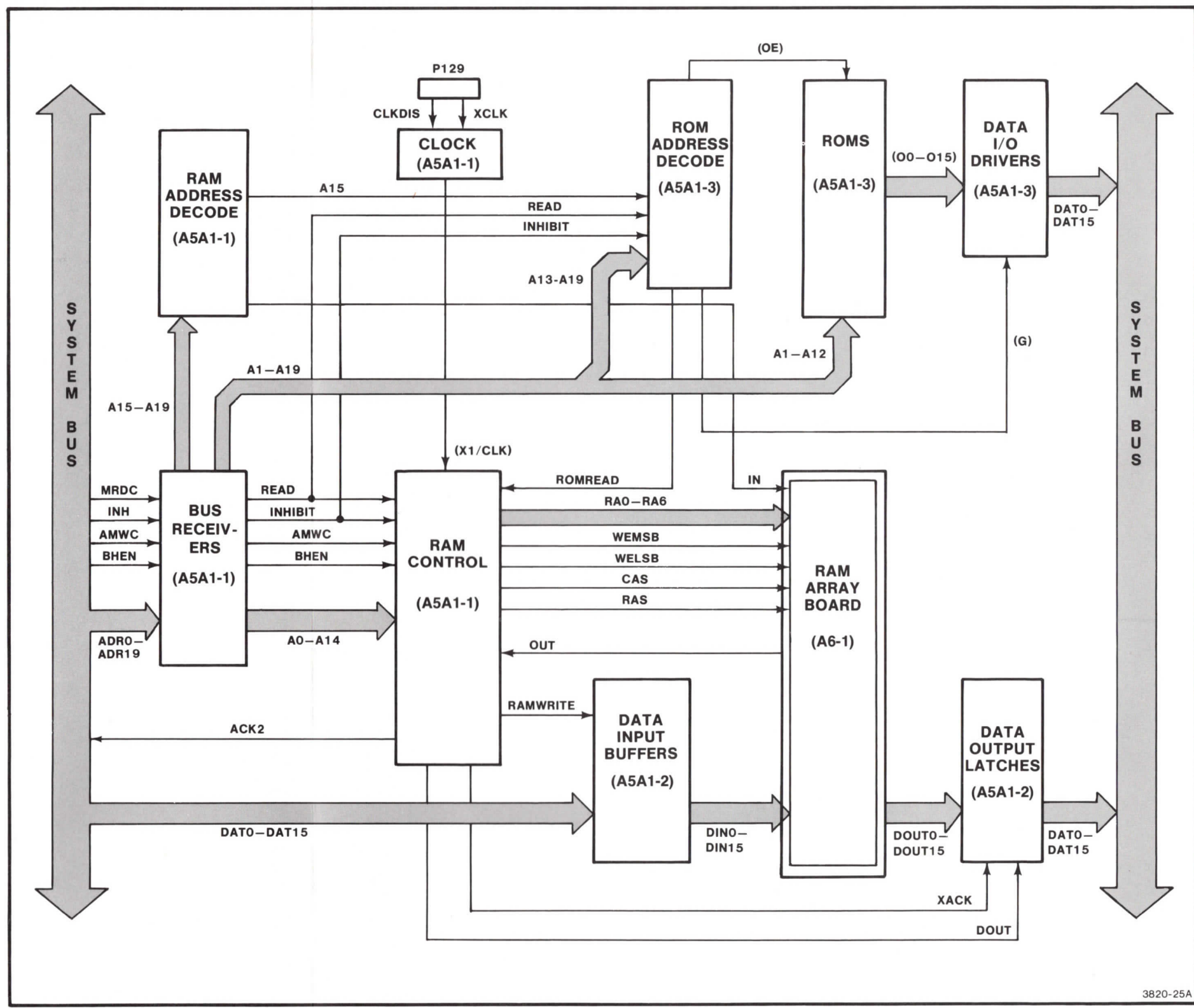

3820-25A

RAM/ROM Block Diagram

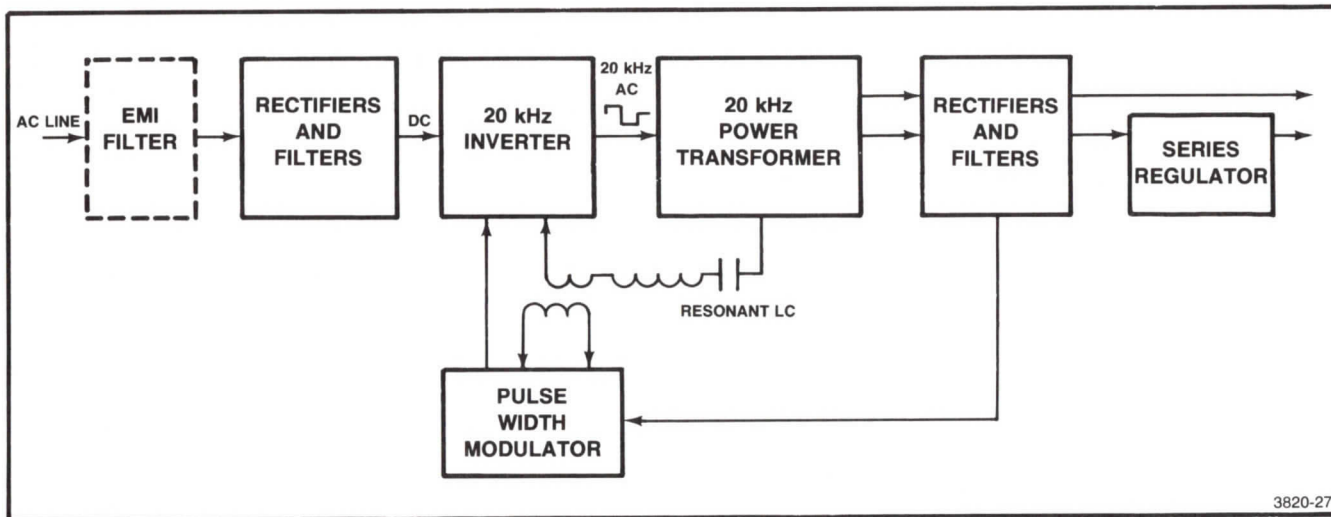

3820-27

High Efficiency Power Supply Block Diagram

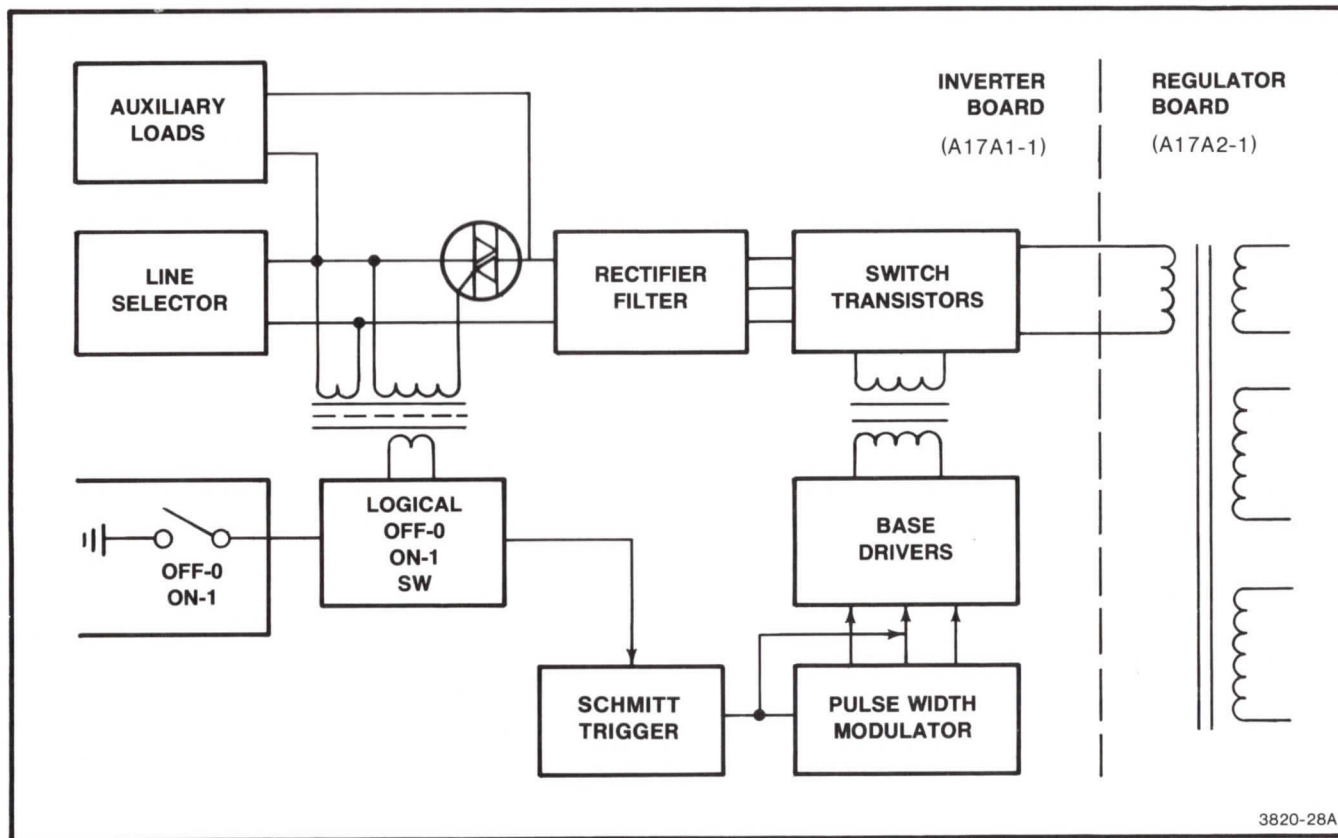

3820-28A

Power Supply Inverter Block Diagram

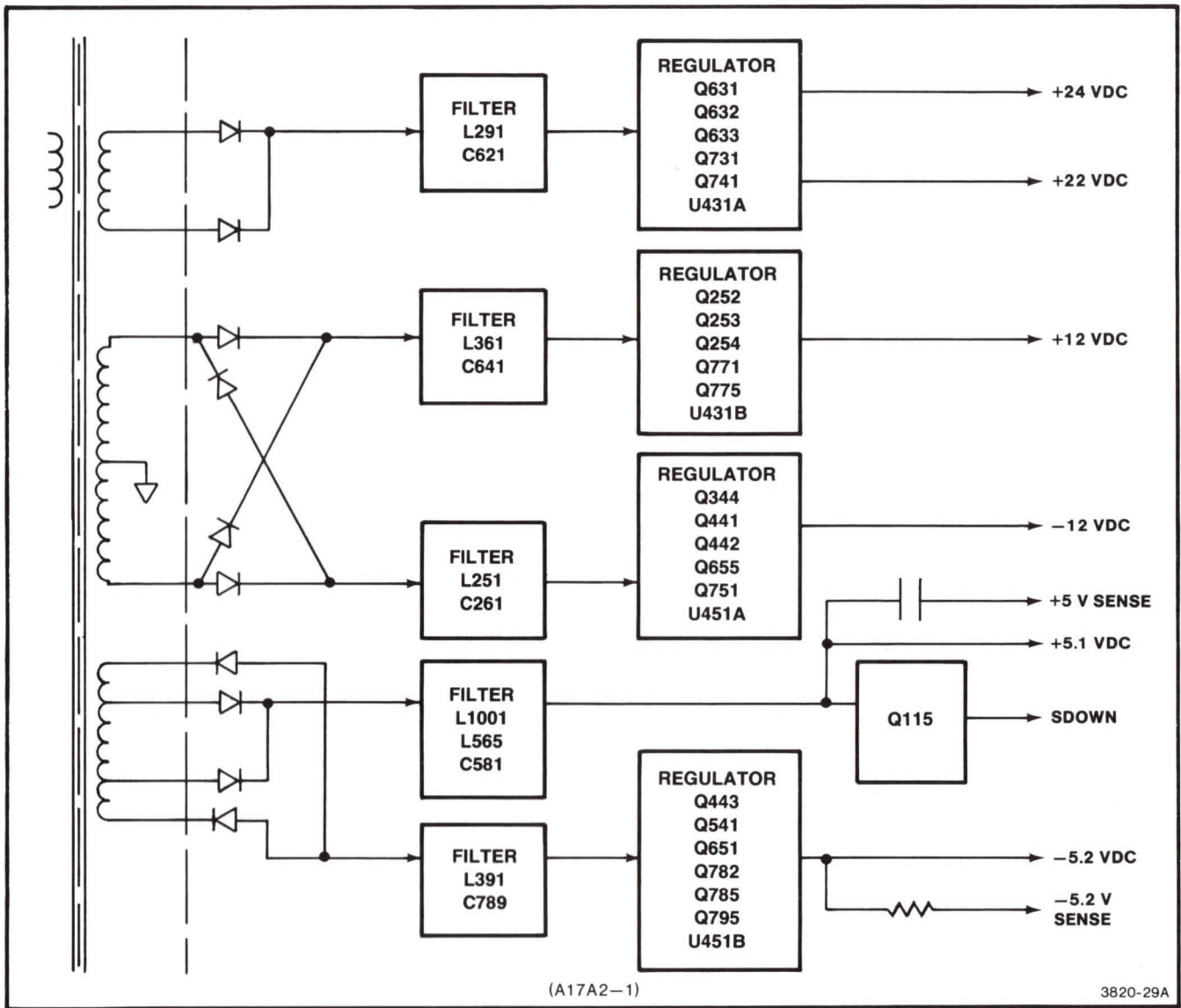

POWER SUPPLY
REGULATOR BLOCK DIAGRAM

Power Supply Regulator Block Diagram

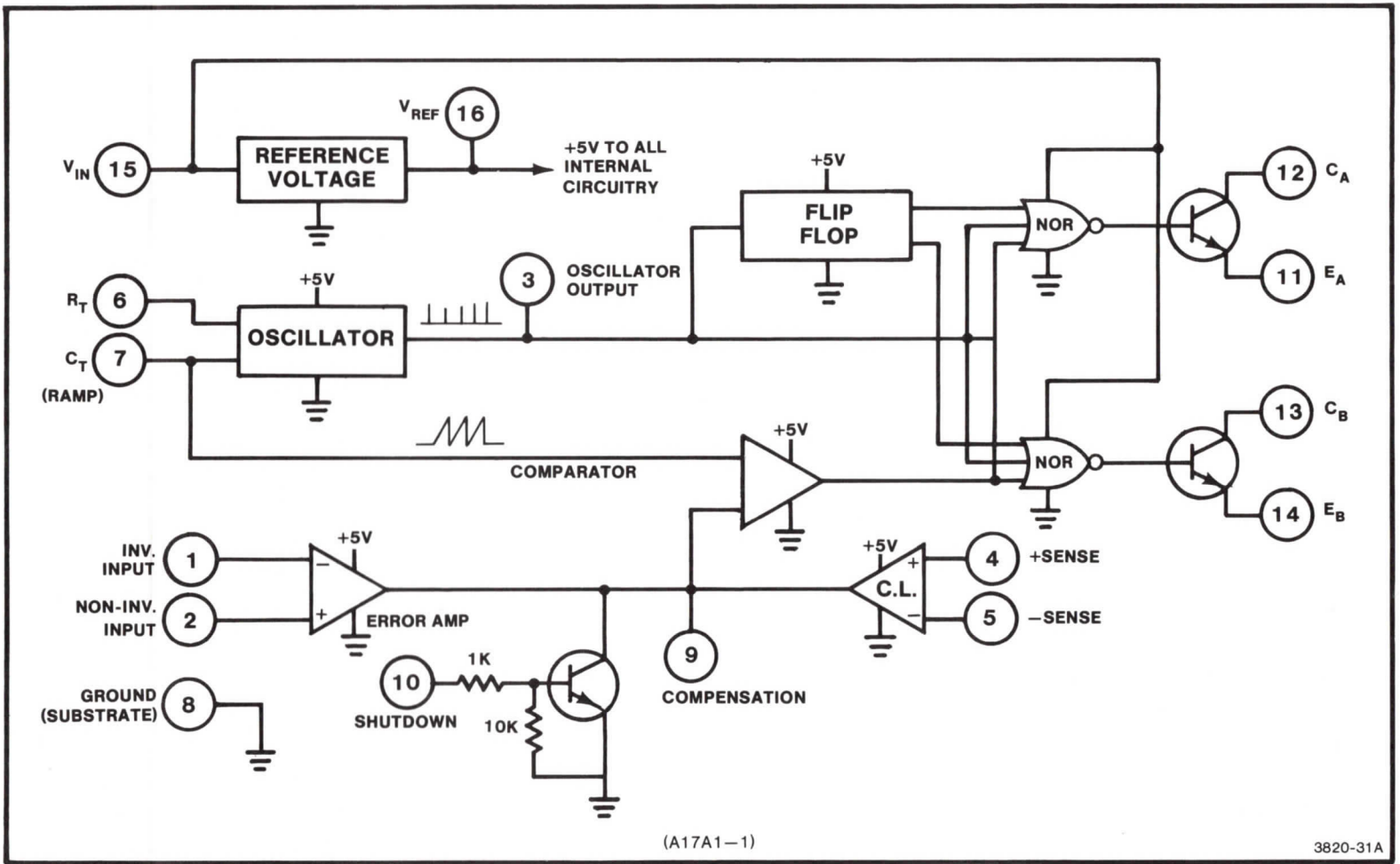

Power Supply Pulse Width Modulator Block Diagram

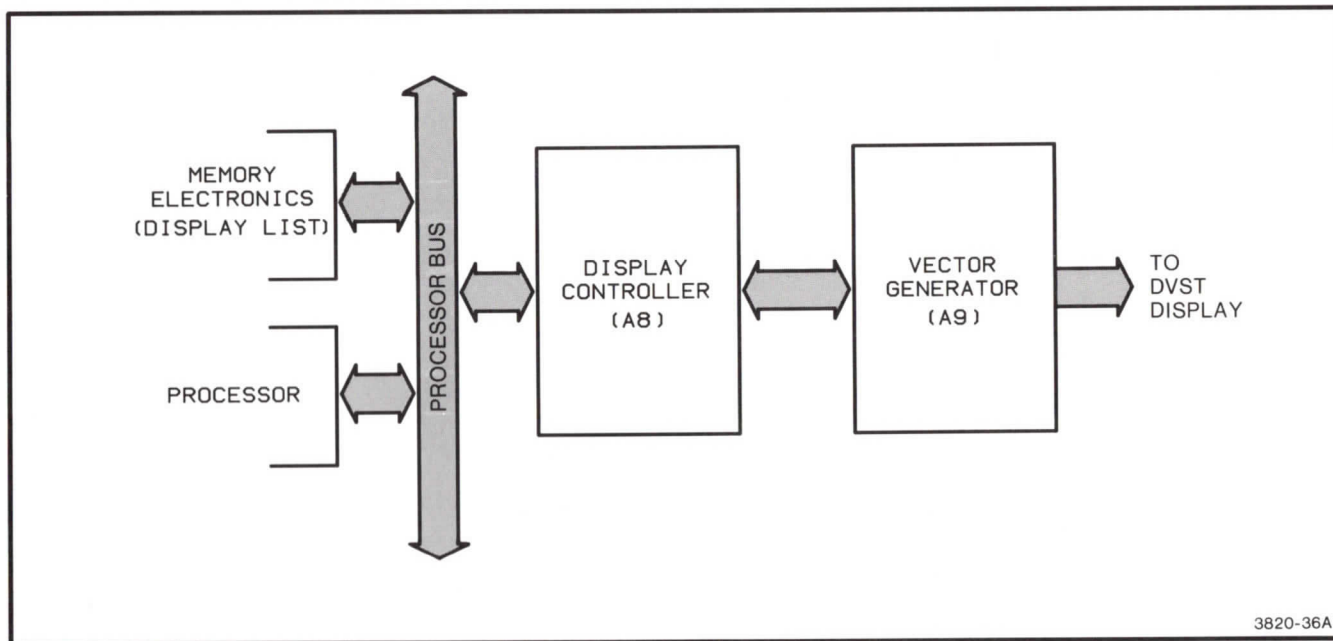

Display Control Circuitry Block Diagram

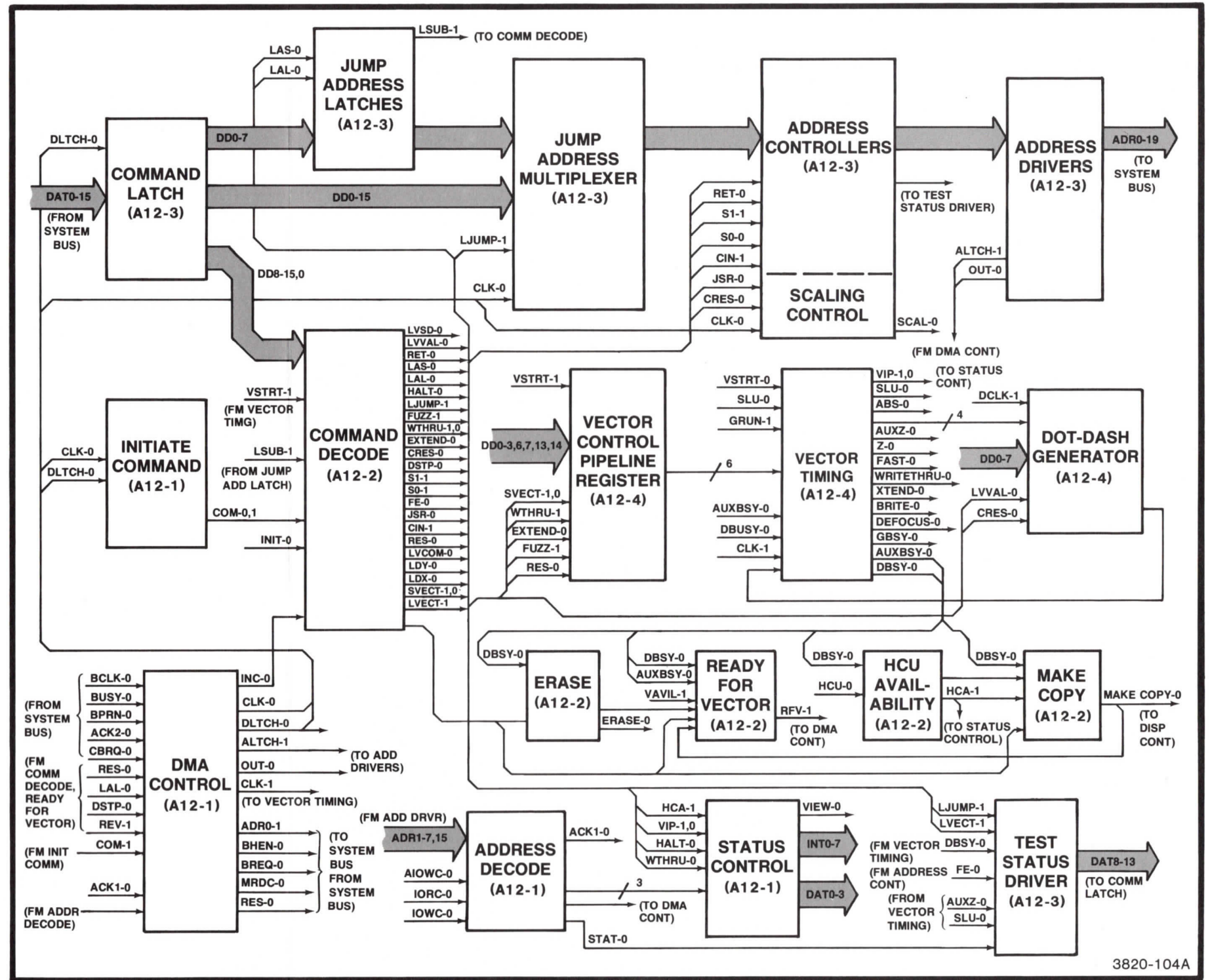

3820-104A

Display Controller Block Diagram

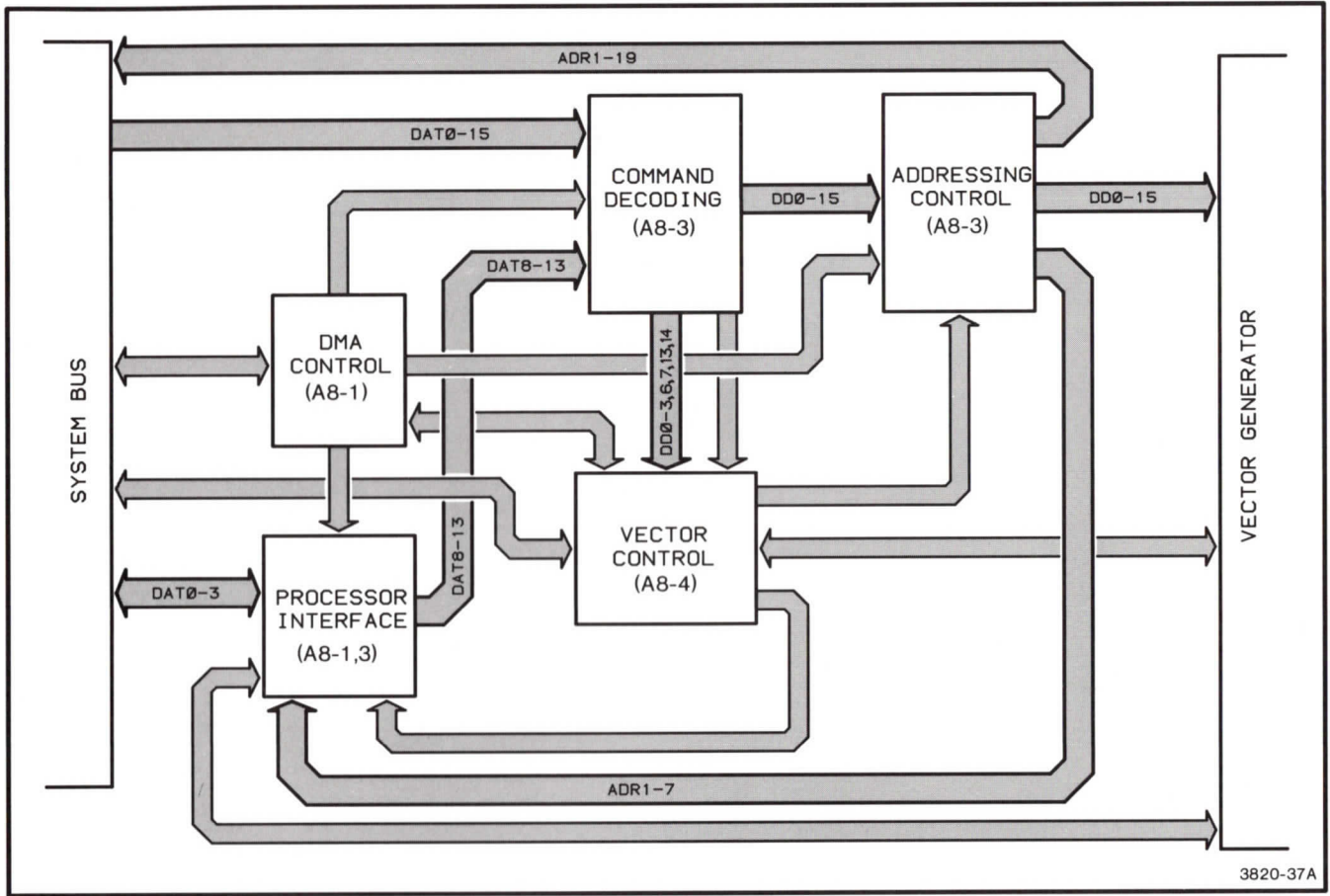

Simplified Display Controller Block Diagram

SIMPLIFIED DISPLAY CONTROLLER
BLOCK DIAGRAM

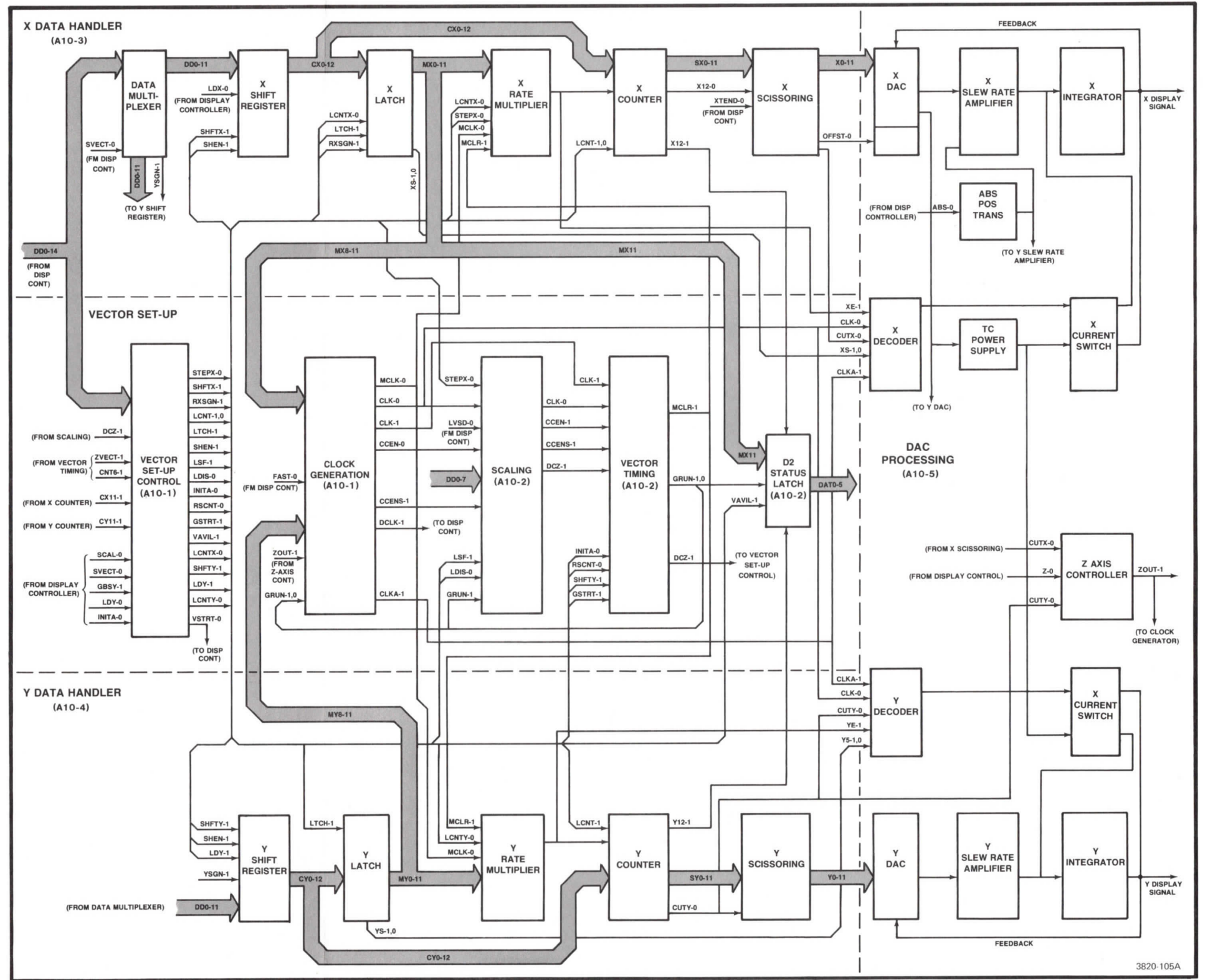

Vector Generator Block Diagram

3820-105A

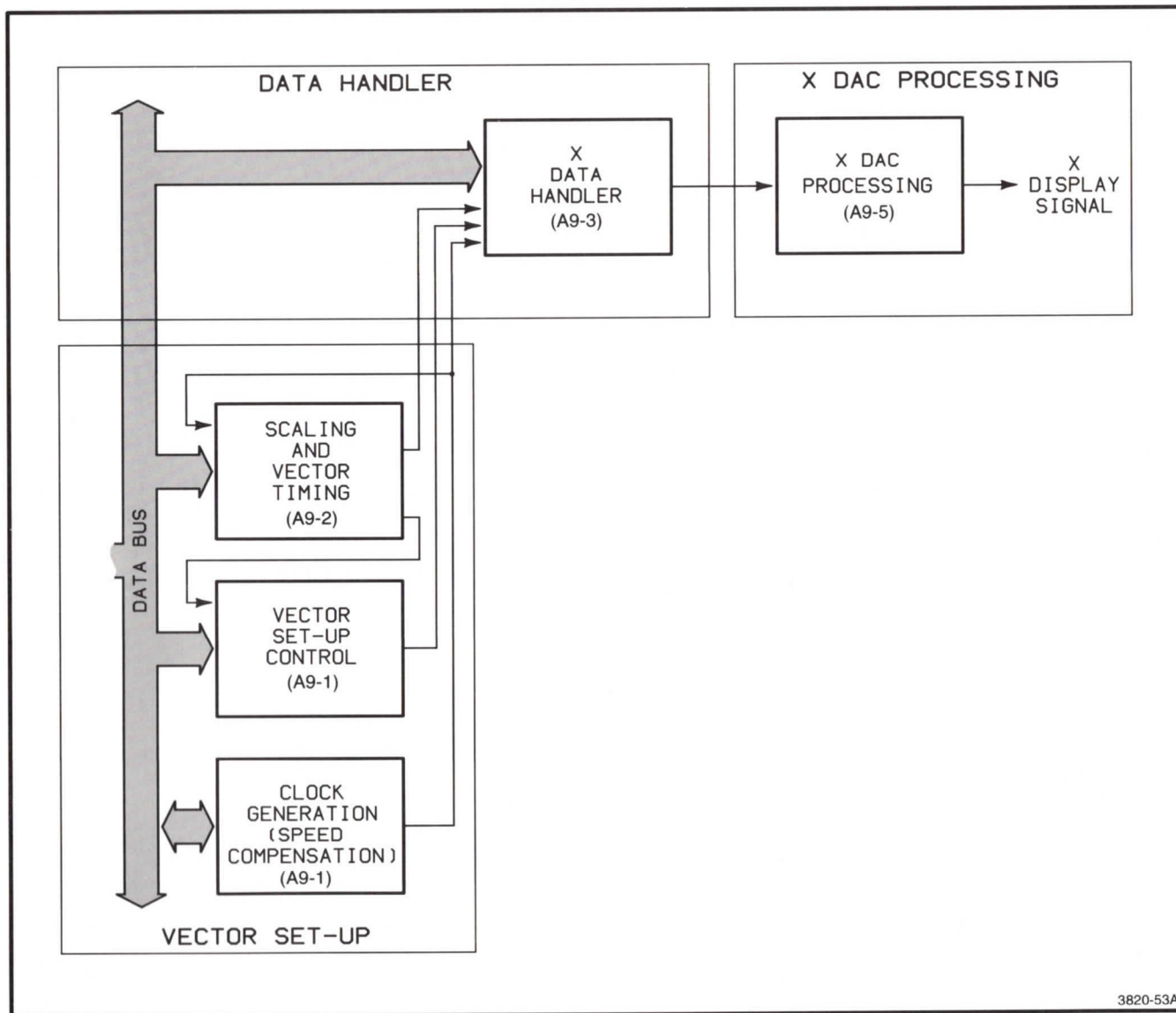

Simplified Vector Generator Block Diagram

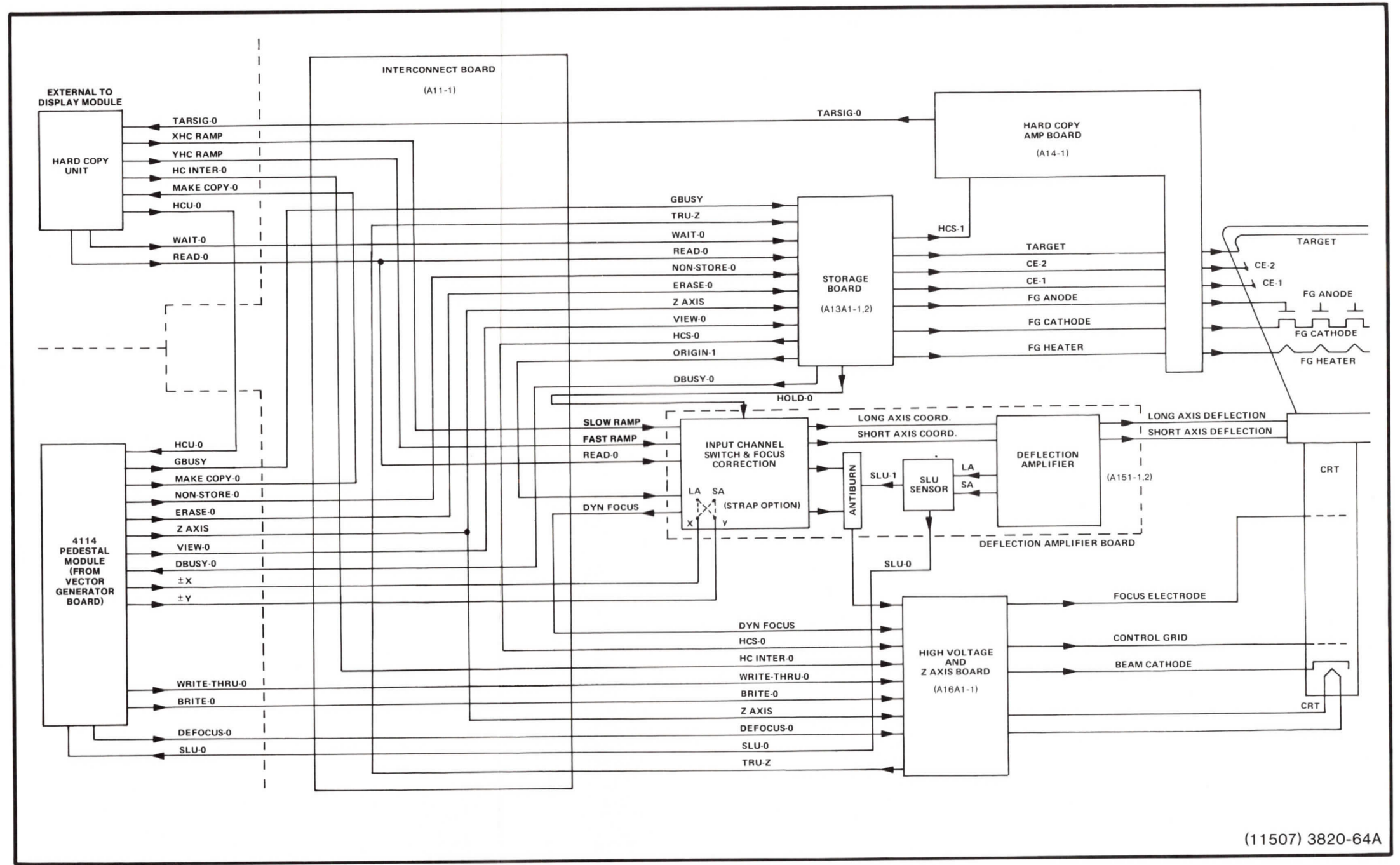

(11507) 3820-64A

Display Module Block Diagram

DISPLAY MODULE
BLOCK DIAGRAM

Section 8

SCHEMATICS

Symbols and Reference Designators

Electrical components shown on the diagrams are in the following units unless noted otherwise:

Capacitors = Values one or greater are in picofarads (pF).
 Values less than one are in microfarads (μ F).

Resistors = Ohms (Ω).

Graphic symbols and class designation letters are based on ANSI Standard Y32.2-1975.

Logic symbology is based on ANSI Y32.14-1973 in terms of positive logic. Logic symbols depict the logic function performed and may differ from the manufacturer's data.

Abbreviations are based on ANSI Y1.1-1972. Other ANSI standards that are used in the preparation of diagrams by Tektronix, Inc., are:

- | | |
|--------------|--|
| Y14.15, 1966 | Drafting Practices. |
| Y14.2, 1973 | Line Conventions and Lettering. |
| Y10.5, 1968 | Letter Symbols for Quantities Used in Electrical Science and Electrical Engineering. |

The following prefix letters are used as reference designators to identify components or assemblies on the diagrams.

A	Assembly, separable or repairable (circuit board, etc.)	H	Heat dissipating device (heat sink, heat radiator, etc.)	S	Switch or contactor
AT	Attenuator, fixed or variable	HR	Heater	T	Transformer
B	Motor	HY	Hybrid circuit	TC	Thermocouple
BT	Battery	J	Connector, stationary portion	TP	Test point
C	Capacitor, fixed or variable	K	Relay	U	Assembly, inseparable or non-repairable (integrated circuit, etc.)
CB	Circuit breaker	L	Inductor, fixed or variable	V	Electron tube
CR	Diode, signal or rectifier	M	Meter	VR	Voltage regulator (zener diode, etc.)
DL	Delay line	P	Connector, movable portion	W	Wirestrap or cable
DS	Indicating device (lamp)	Q	Transistor or silicon-controlled rectifier	Y	Crystal
E	Spark Gap, Ferrite bead	R	Resistor, fixed or variable	Z	Phase shifter
F	Fuse	RT	Thermistor		
FL	Filter				

The following special symbols may appear on the diagrams:

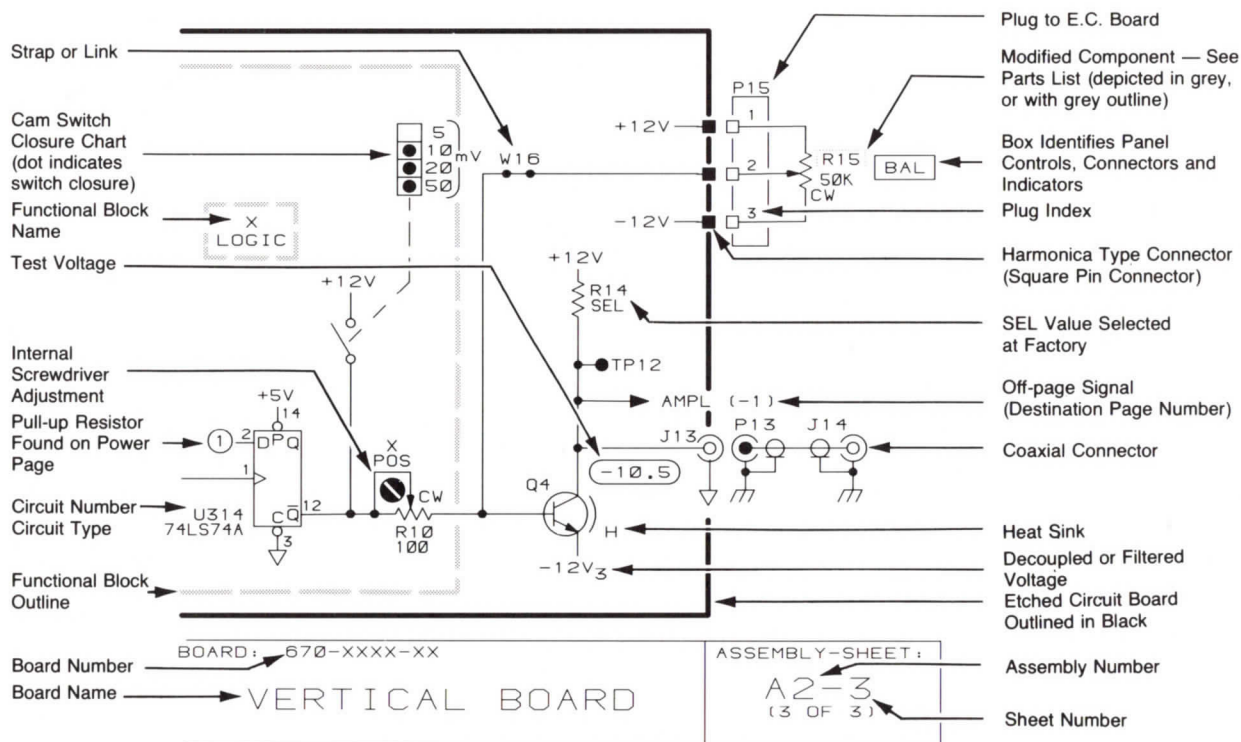

SCHEMATICS

1. True High and True Low Signals

Signal names on the schematics are followed by -1 or a -0. A TRUE HIGH signal is indicated by -1, and a TRUE LOW signal is indicated by -0.

SIGNAL -1 = TRUE HIGH
SIGNAL -0 = TRUE LOW

2. Cross-References

Schematic cross-references (from/to information) are included on the schematics. The "from" reference only indicates the signal "source," and the "to" reference lists all loads where the signal is used. All from/to information will be enclosed in parentheses.

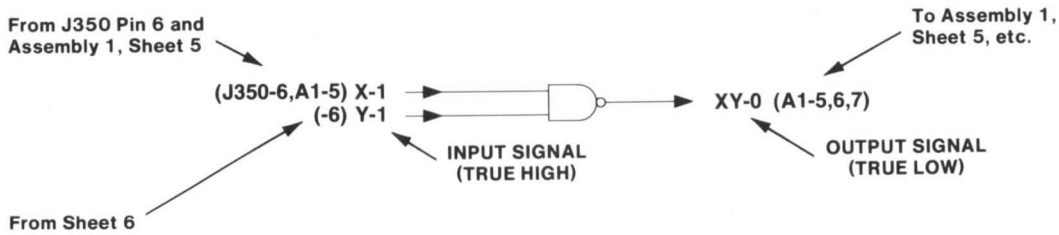

3. Component Number Example

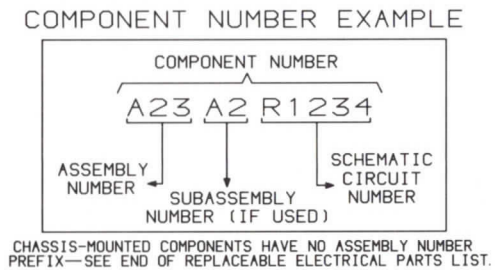

4114 SCHEMATICS

Name	Assembly No./Sheet(s)	Part Number(s)
Motherboard	A1-1,-2	670-7062-00,01
Motherboard Extender (Opt. 40/41)	A2-1	670-7063-00,01
Processor	A3A1-1,-2,-3,-4,-5	672-0949-00
Keyboard	A4-1	119-1305-03
RAM/ROM	A5A1-1,-1A,-2,-3	672-0950-00,01,02
RAM Array	A6-1	670-6670-00
RAM Controller	A7-1,-1A,-2	670-6669-00,01,02
Display Controller	A8-1,-2,-3,-4	670-6494-02
Vector Generator	A9-1,-2,-3,-4,-5	670-6495-00
41XX Logic Extender	A10-1,-2	670-5291-00
Interconnect	A11-1	670-5163-01
LVPS	A12-1	670-4798-03
Double Erase Storage	A13A1-1,-2	672-0795-04
Hard Copy Amplifier	A14-1	670-3097-01
Deflection Amplifier	A15A1-1,-2	672-0901-01
High Voltage & Z-Axis	A16A1-1	672-0662-04
Inverter	A17A1-1	670-6503-01,02,03
Regulator	A17A2-1	670-6502-00,01

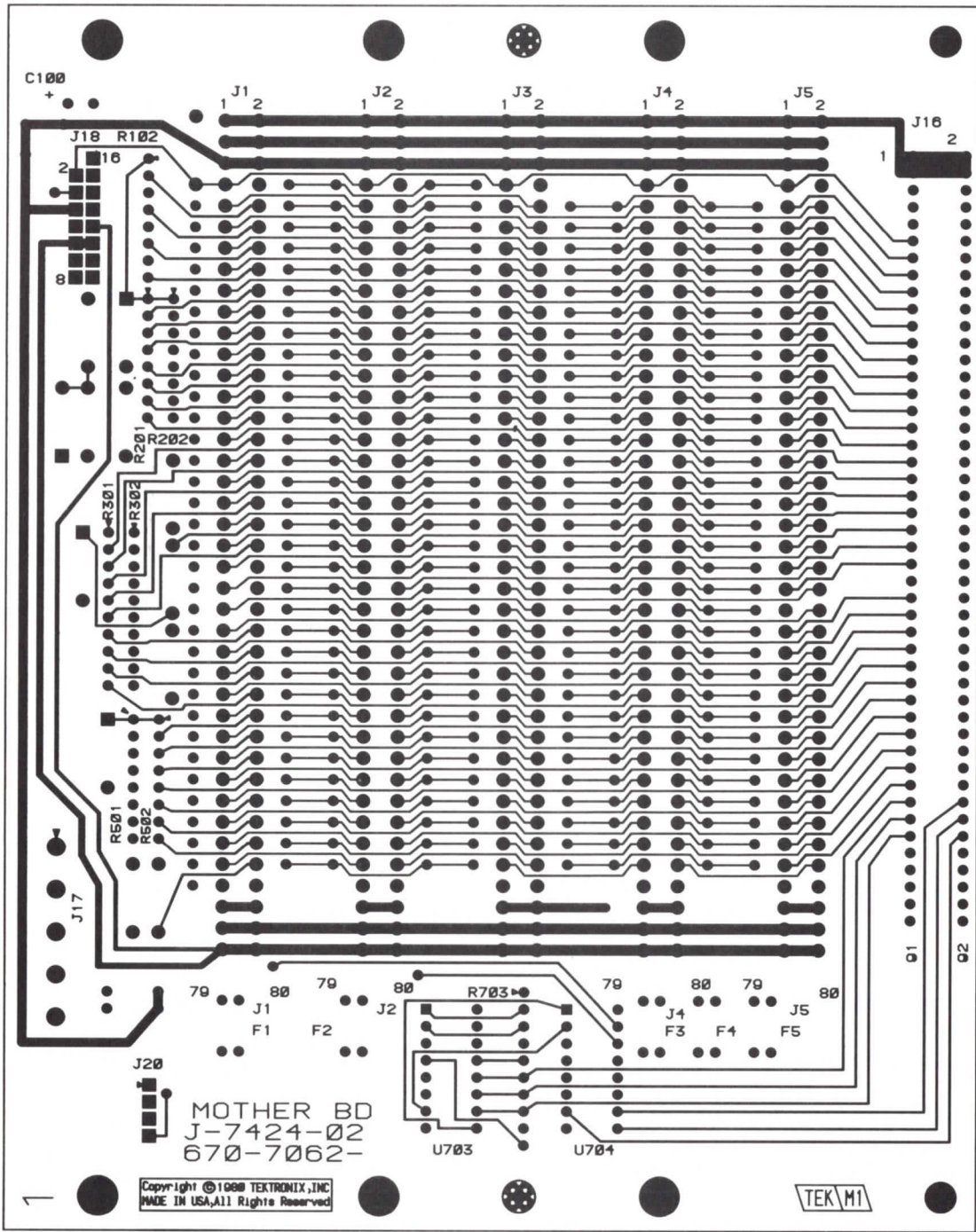

3818-92

Motherboard (670-7062-00,01) Component Locations.

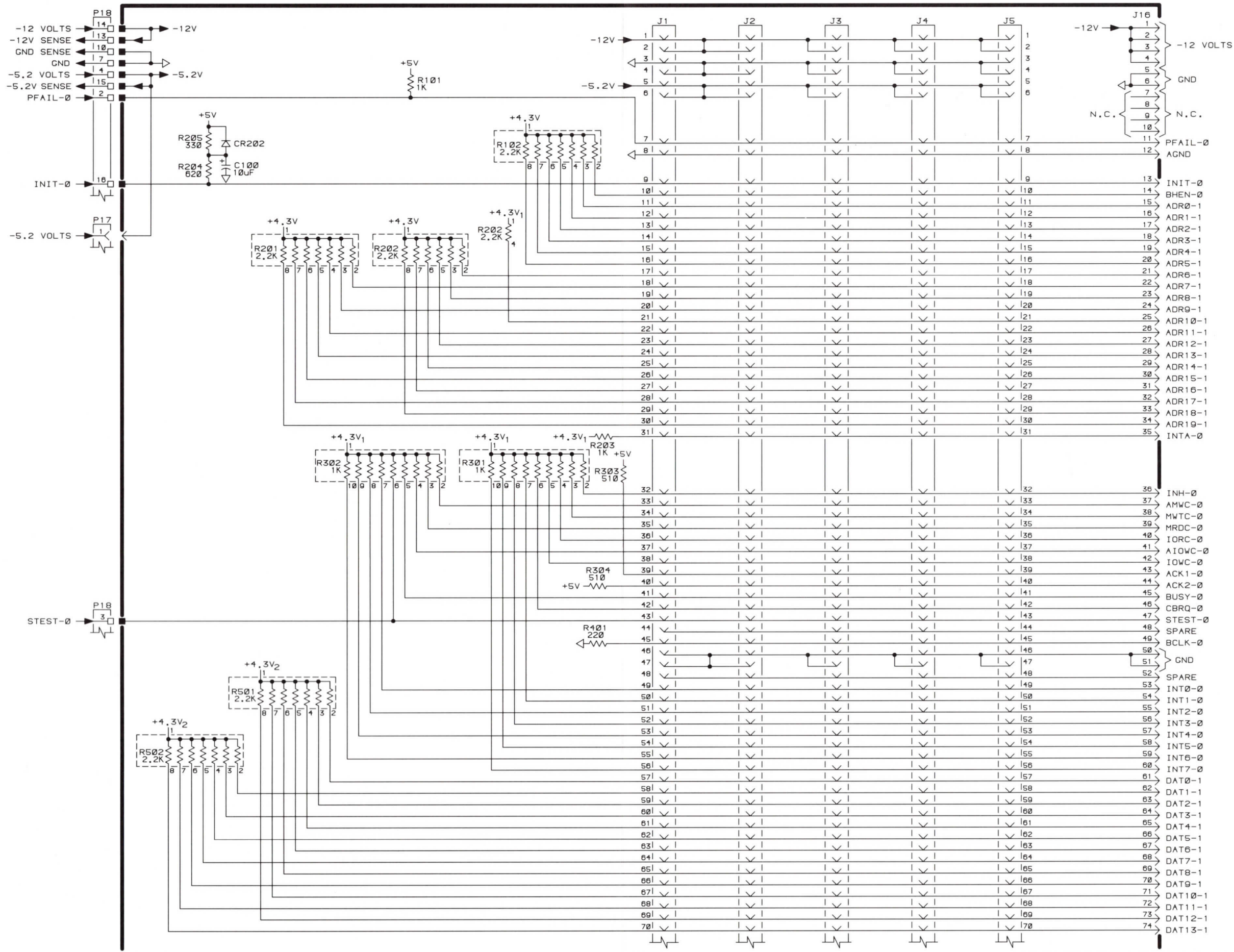

4114

REV, AUG 1982
3818-2

670-7062-00,01 MOTHERBOARD A1-1
(1 OF 2)

MOTHERBOARD
670-7062-00,01

A1-1

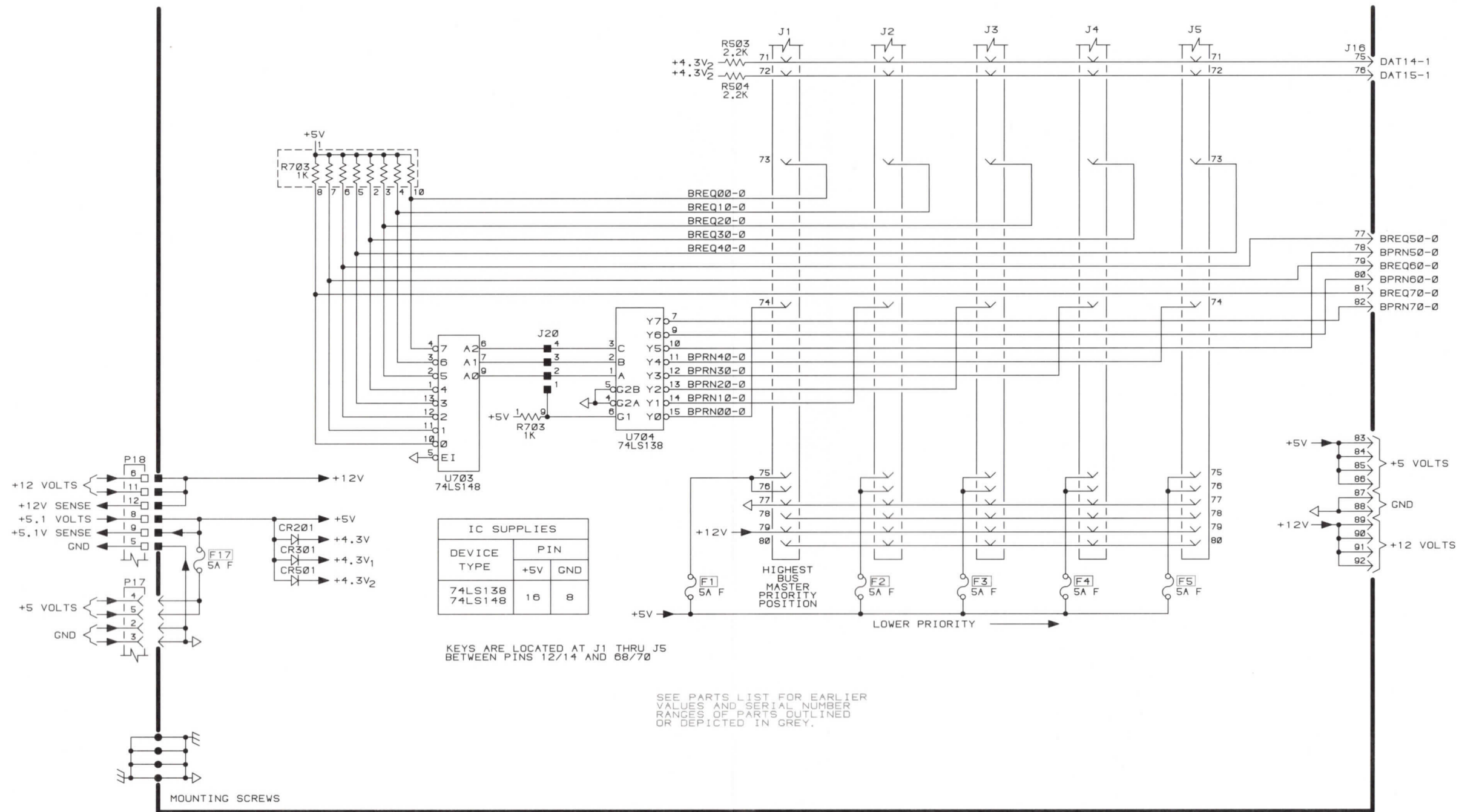

4114

REV, JUN 1982
3818-3

670-7062-00,01 MOTHERBOARD A1-2
(2 OF 2)

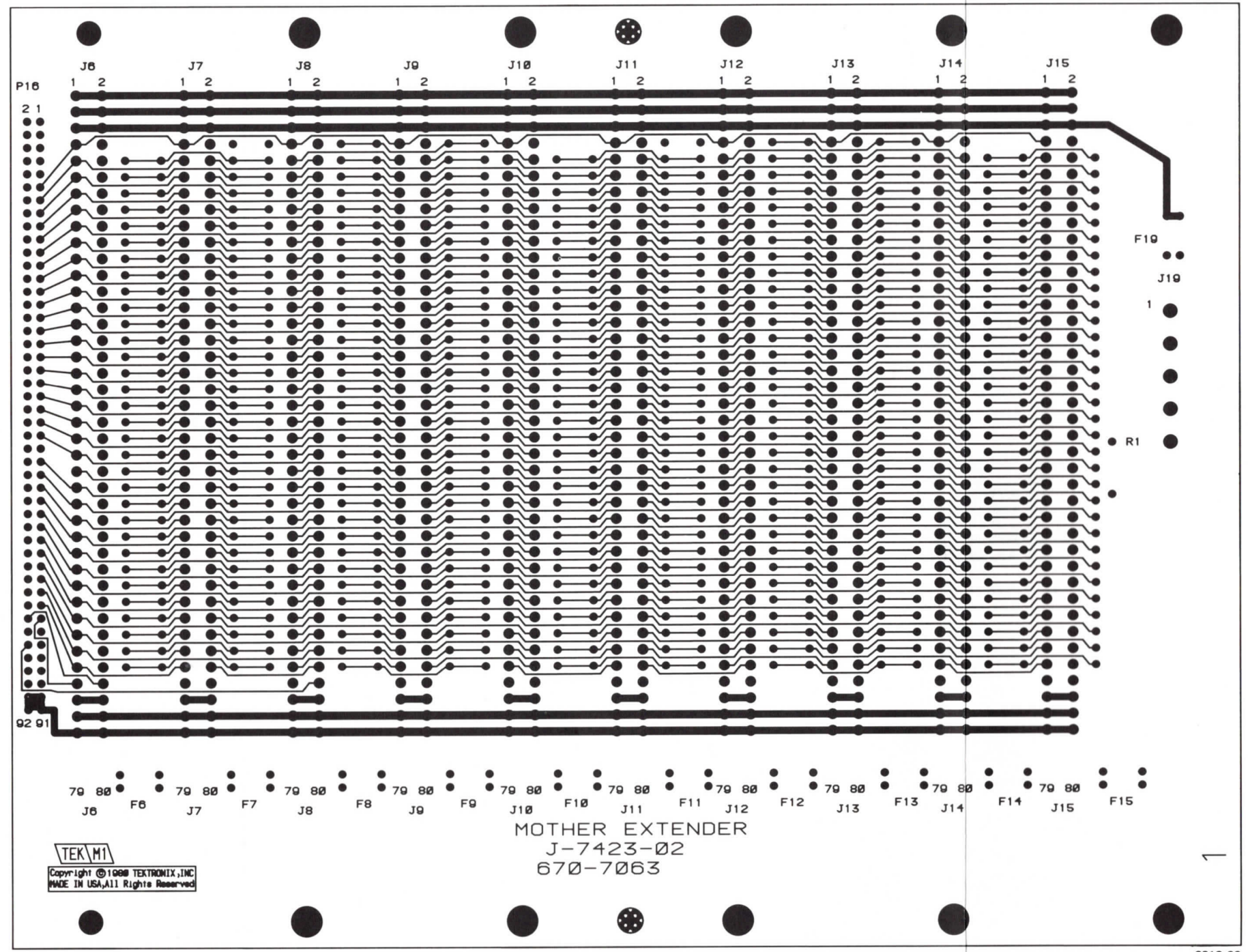

3818-93

Motherboard Extender (Option 40/41) (670-7063-00,01) Component Locations.

MOTHERBOARD EXTENDER (OPT. 40/41)
COMPONENT LOCATIONS



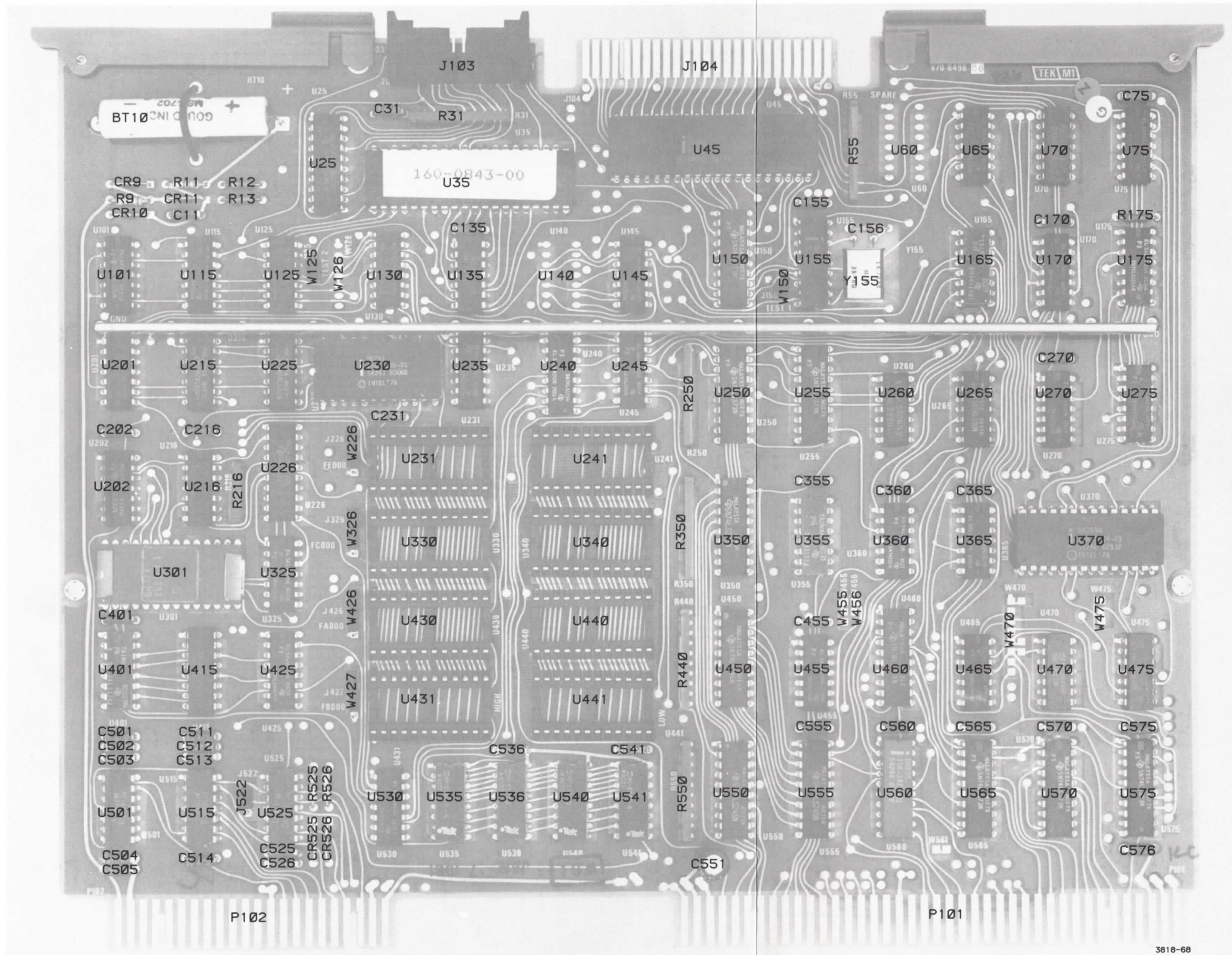

Processor Board (672-0949-00) Component Locations.

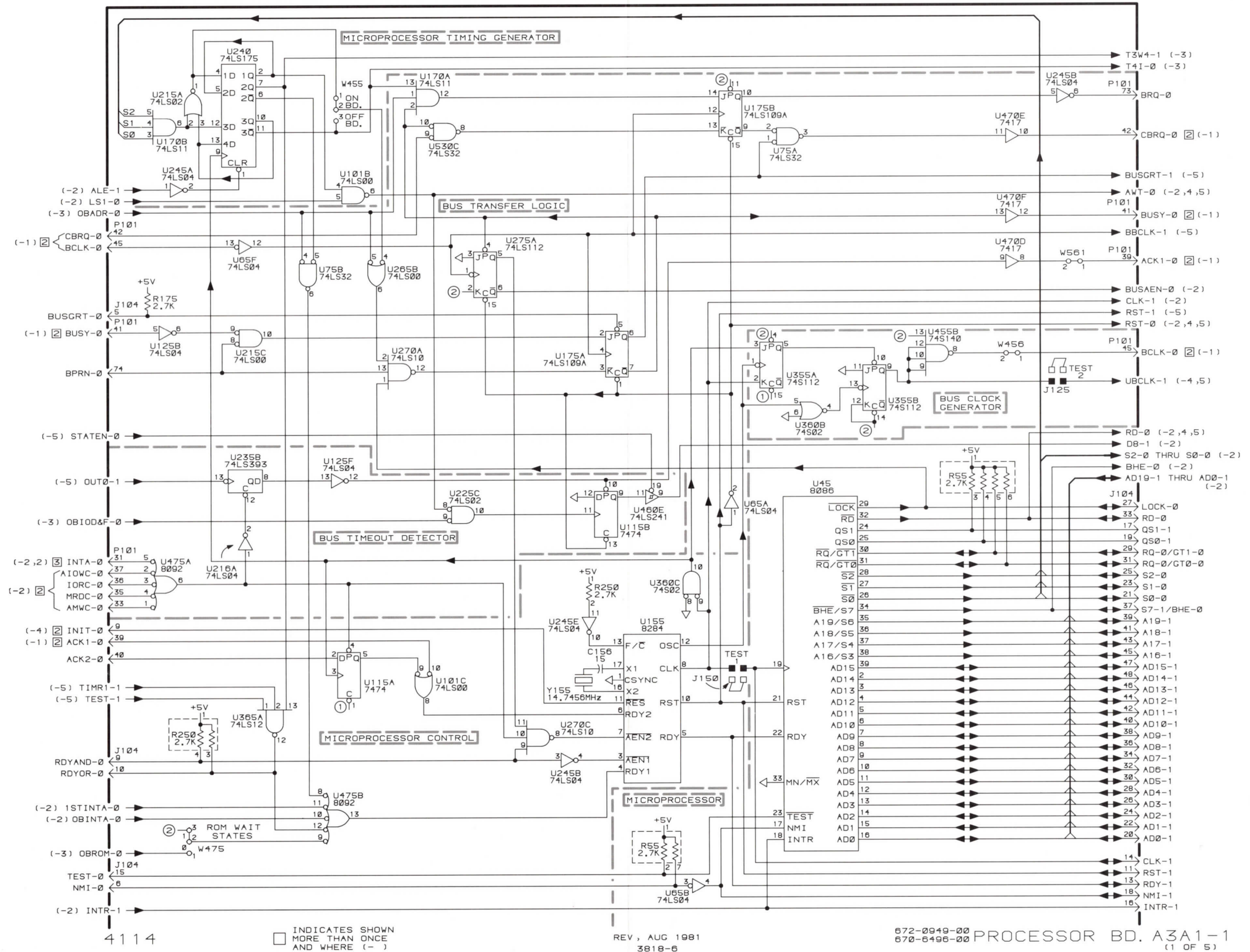

4114

INDICATES SHOWN MORE THAN ONCE AND WHERE (-)

REV, AUG 1981 3818-6

672-0949-00 PROCESSOR BD. A3A1-1
670-6496-00 (1 OF 5)

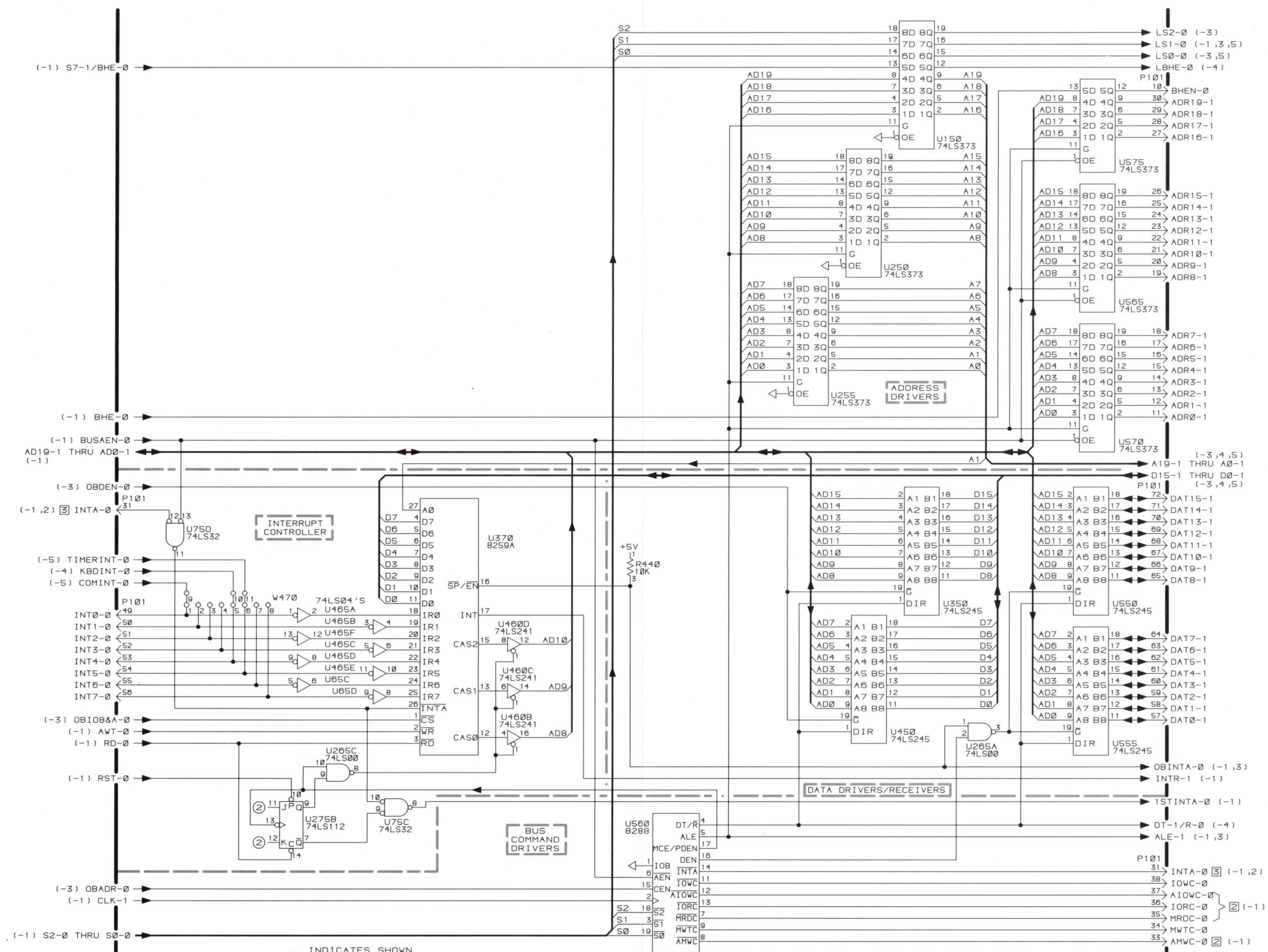

4114

INDICATES SHOWN MORE THAN ONCE AND WHERE (-)

REV, AUG 1981 3818-7

672-0949-00 PROCESSOR BD. A3A1-2 (2 OF 5)

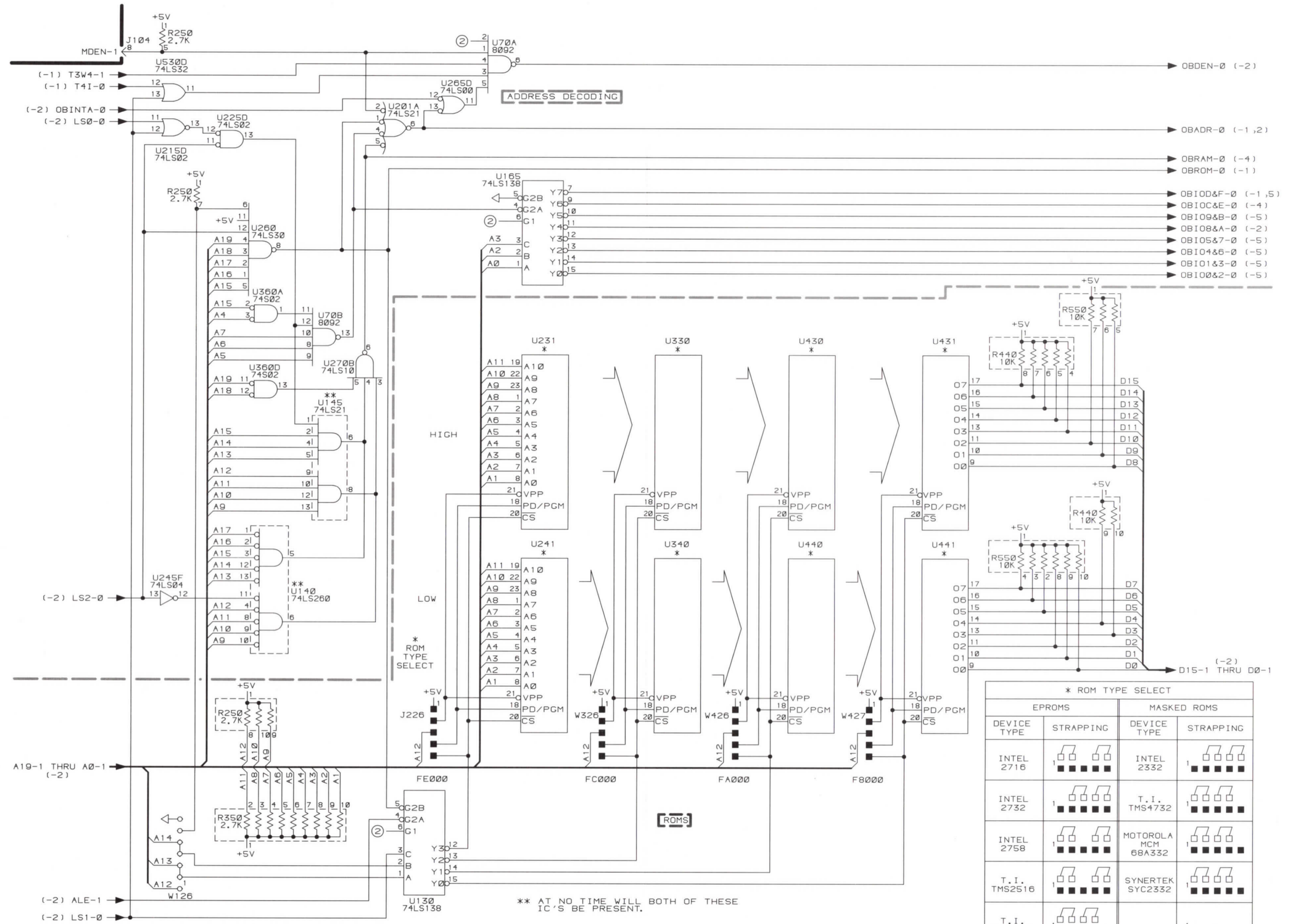

* ROM TYPE SELECT

EPROMS		MASKED ROMS	
DEVICE TYPE	STRAPPING	DEVICE TYPE	STRAPPING
INTEL 2716	1 <input type="checkbox"/> 2 <input type="checkbox"/> 3 <input type="checkbox"/>	INTEL 2332	1 <input type="checkbox"/> 2 <input type="checkbox"/> 3 <input type="checkbox"/> 4 <input type="checkbox"/>
INTEL 2732	1 <input type="checkbox"/> 2 <input type="checkbox"/> 3 <input type="checkbox"/> 4 <input type="checkbox"/>	T.I. TMS4732	1 <input type="checkbox"/> 2 <input type="checkbox"/> 3 <input type="checkbox"/> 4 <input type="checkbox"/>
INTEL 2758	1 <input type="checkbox"/> 2 <input type="checkbox"/> 3 <input type="checkbox"/> 4 <input type="checkbox"/>	MOTOROLA MCM 68A332	1 <input type="checkbox"/> 2 <input type="checkbox"/> 3 <input type="checkbox"/> 4 <input type="checkbox"/>
T.I. TMS2516	1 <input type="checkbox"/> 2 <input type="checkbox"/> 3 <input type="checkbox"/> 4 <input type="checkbox"/>	SYNERTEK SYC2332	1 <input type="checkbox"/> 2 <input type="checkbox"/> 3 <input type="checkbox"/> 4 <input type="checkbox"/>
T.I. TMS2532	1 <input type="checkbox"/> 2 <input type="checkbox"/> 3 <input type="checkbox"/> 4 <input type="checkbox"/>		1 <input type="checkbox"/> 2 <input type="checkbox"/> 3 <input type="checkbox"/> 4 <input type="checkbox"/>

4114

3818-8

672-0949-00
670-6496-00 PROCESSOR BD. A3A1-3 (3 OF 5)

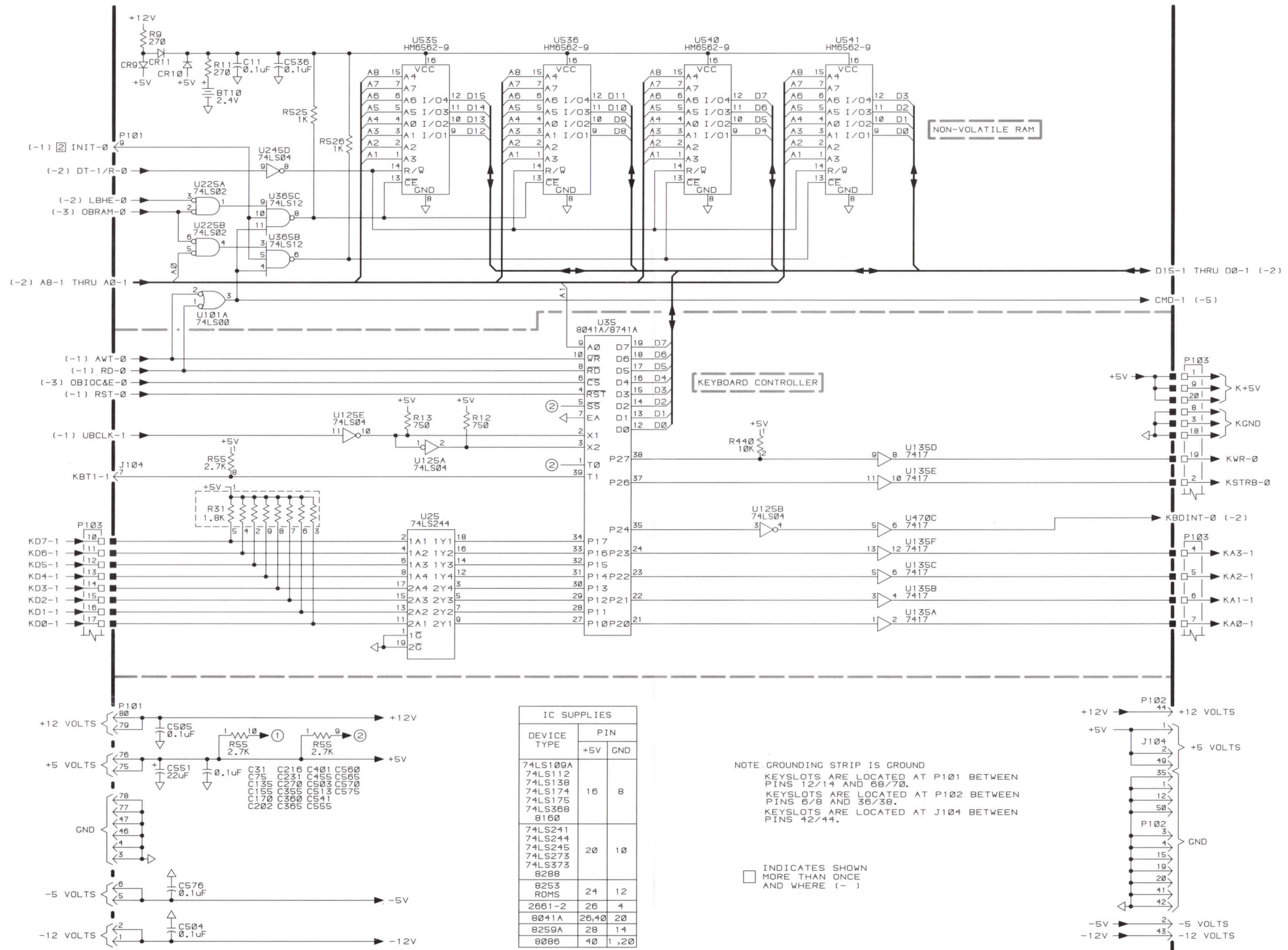

IC SUPPLIES

DEVICE TYPE	PIN	
	+5V	GND
74LS109A		
74LS112		
74LS138		
74LS174	16	8
74LS175		
74LS368		
8160		
74LS241		
74LS244	20	10
74LS245		
74LS273		
74LS373		
8288		
8253 ROMS	24	12
2661-2	26	4
8041A	26,40	20
8259A	28	14
8086	40	1,20

NOTE: GROUNDING STRIP IS GROUND
KEYSLOTS ARE LOCATED AT P101 BETWEEN PINS 12/14 AND 68/70.
KEYSLOTS ARE LOCATED AT P102 BETWEEN PINS 6/8 AND 36/38.
KEYSLOTS ARE LOCATED AT J104 BETWEEN PINS 42/44.

□ INDICATES SHOWN MORE THAN ONCE AND WHERE (-)

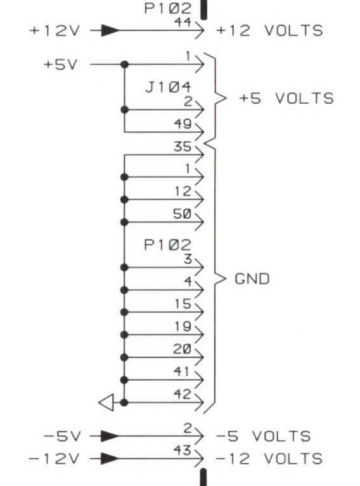
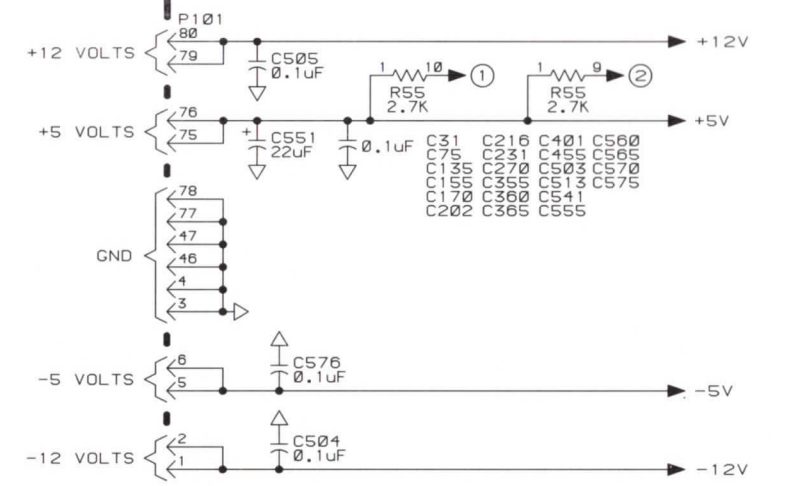

4114

3818-9

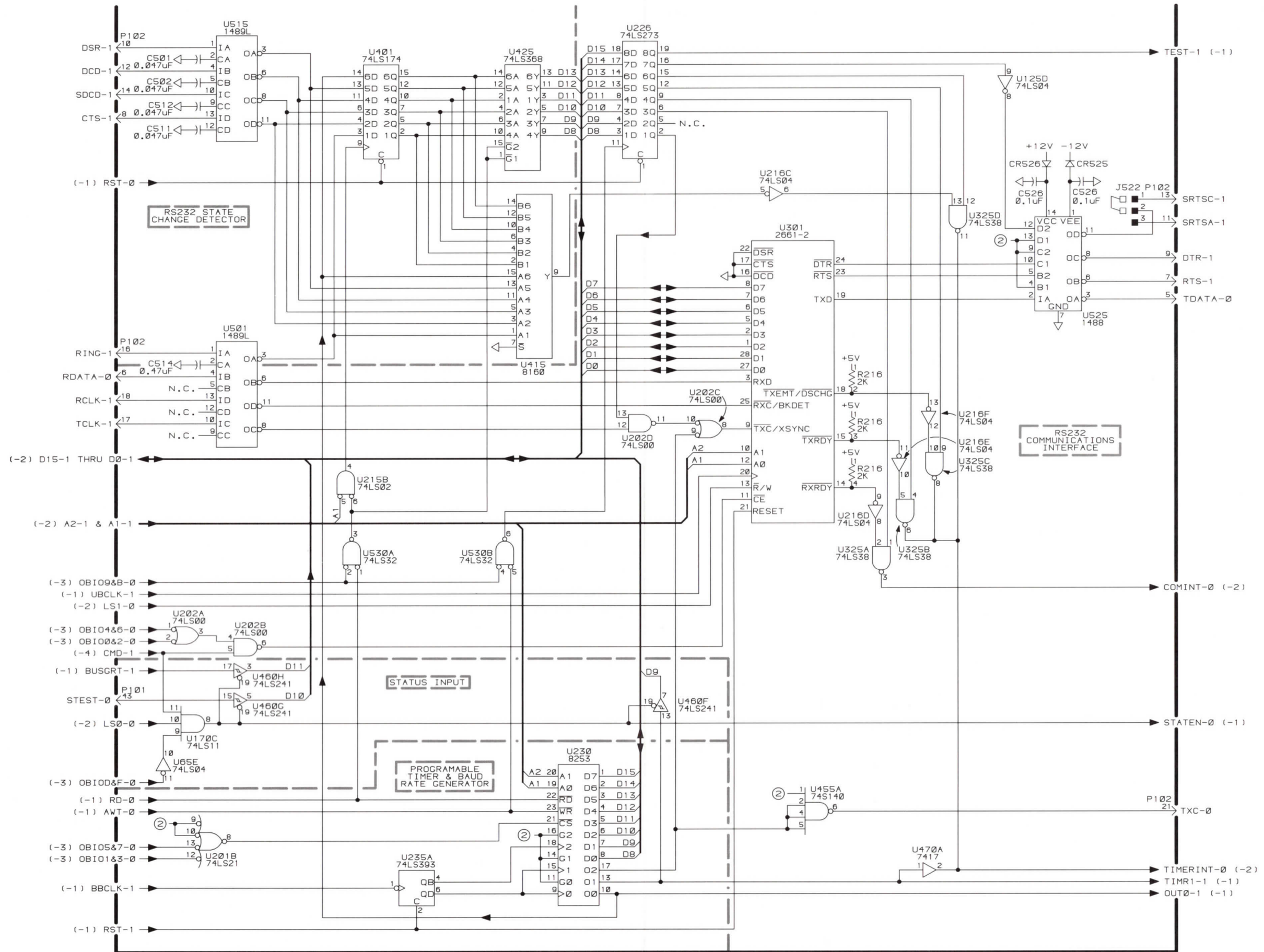

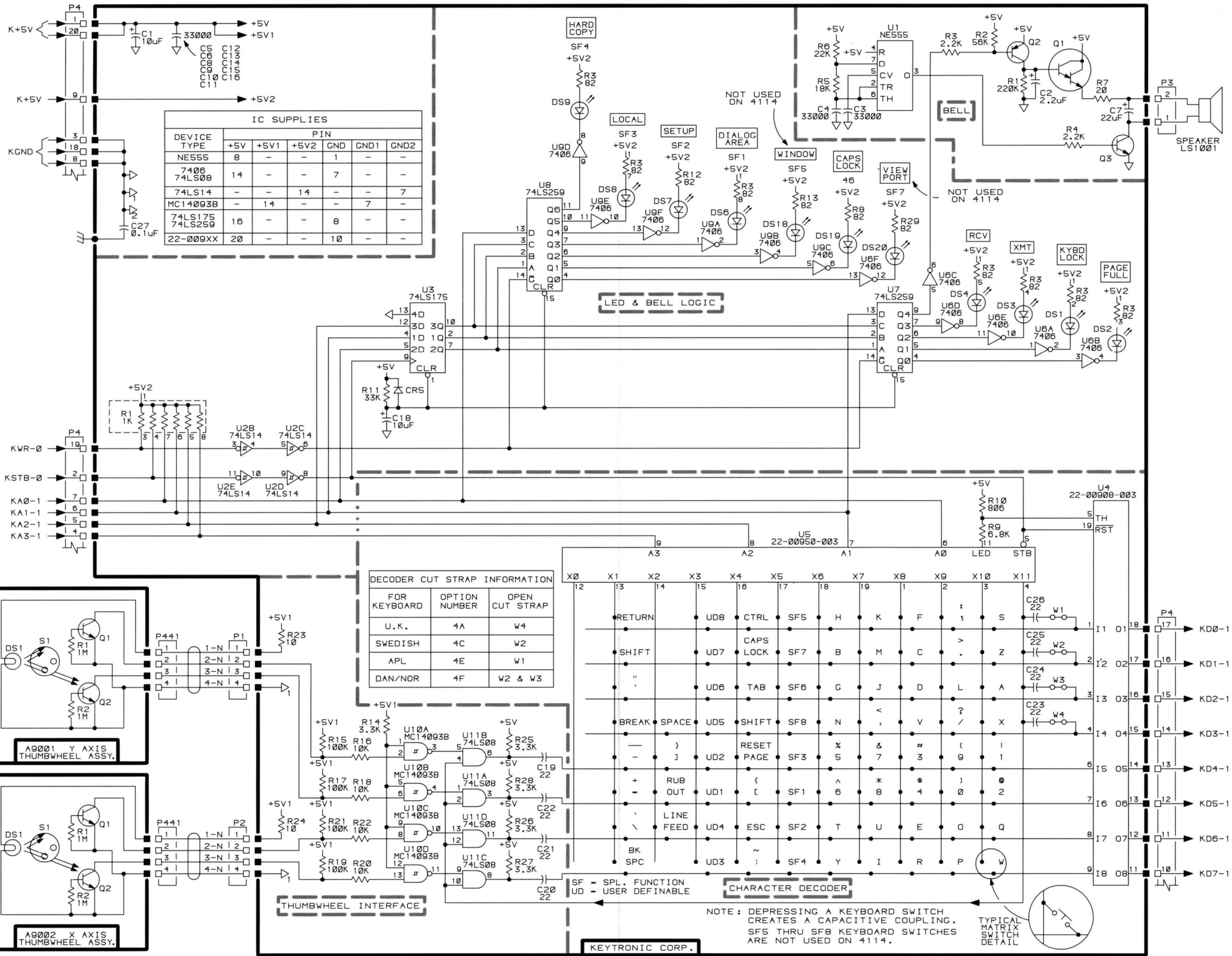

119-1305-03
(FOR USE WITH 4114)

REV, JUN 1982
3818-11

KEYBOARD A4-1
(1 OF 1)

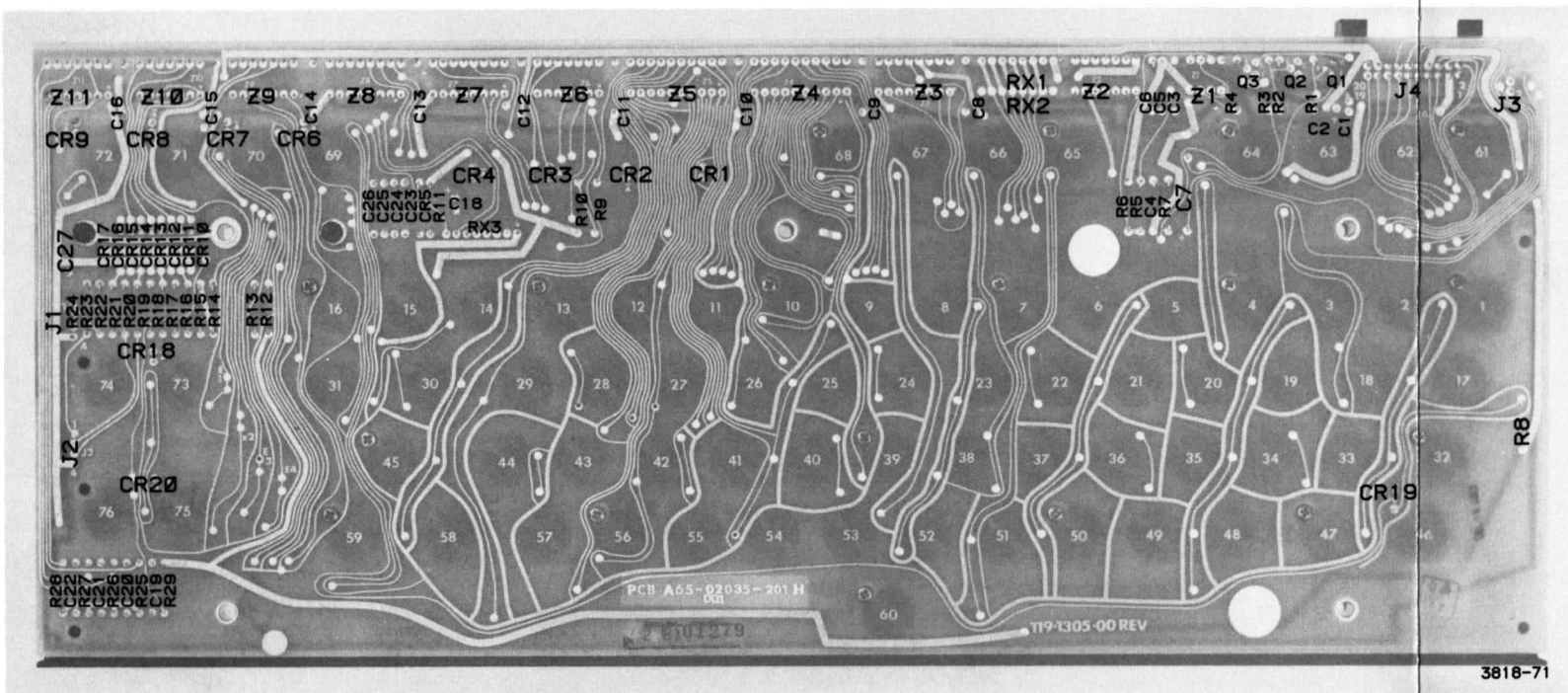

Keyboard (119-1305-03) Component Locations.

RAM/ROM
COMPONENT LOCATIONS

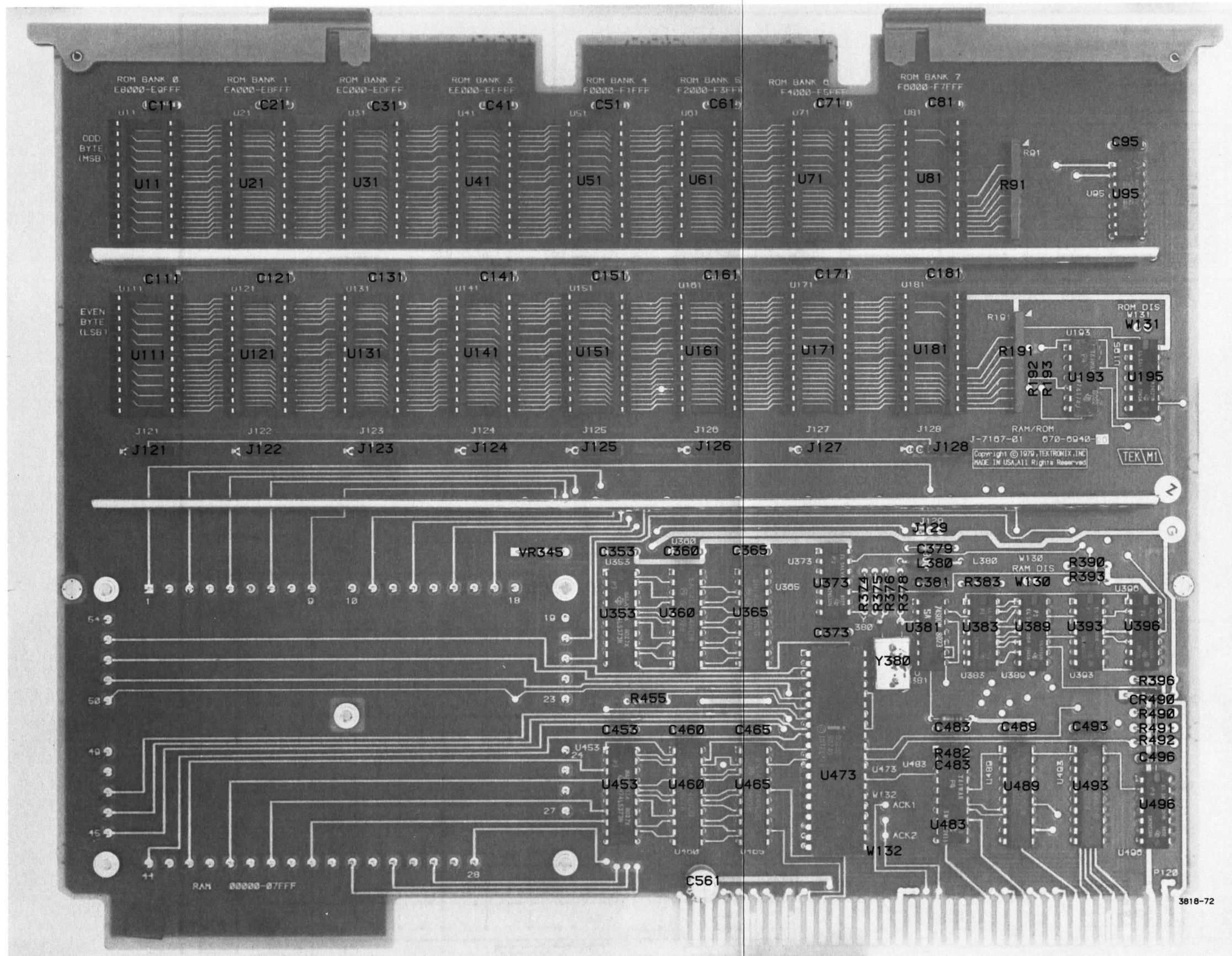

RAM/ROM Board (672-0950-00,01,02) Component Locations.

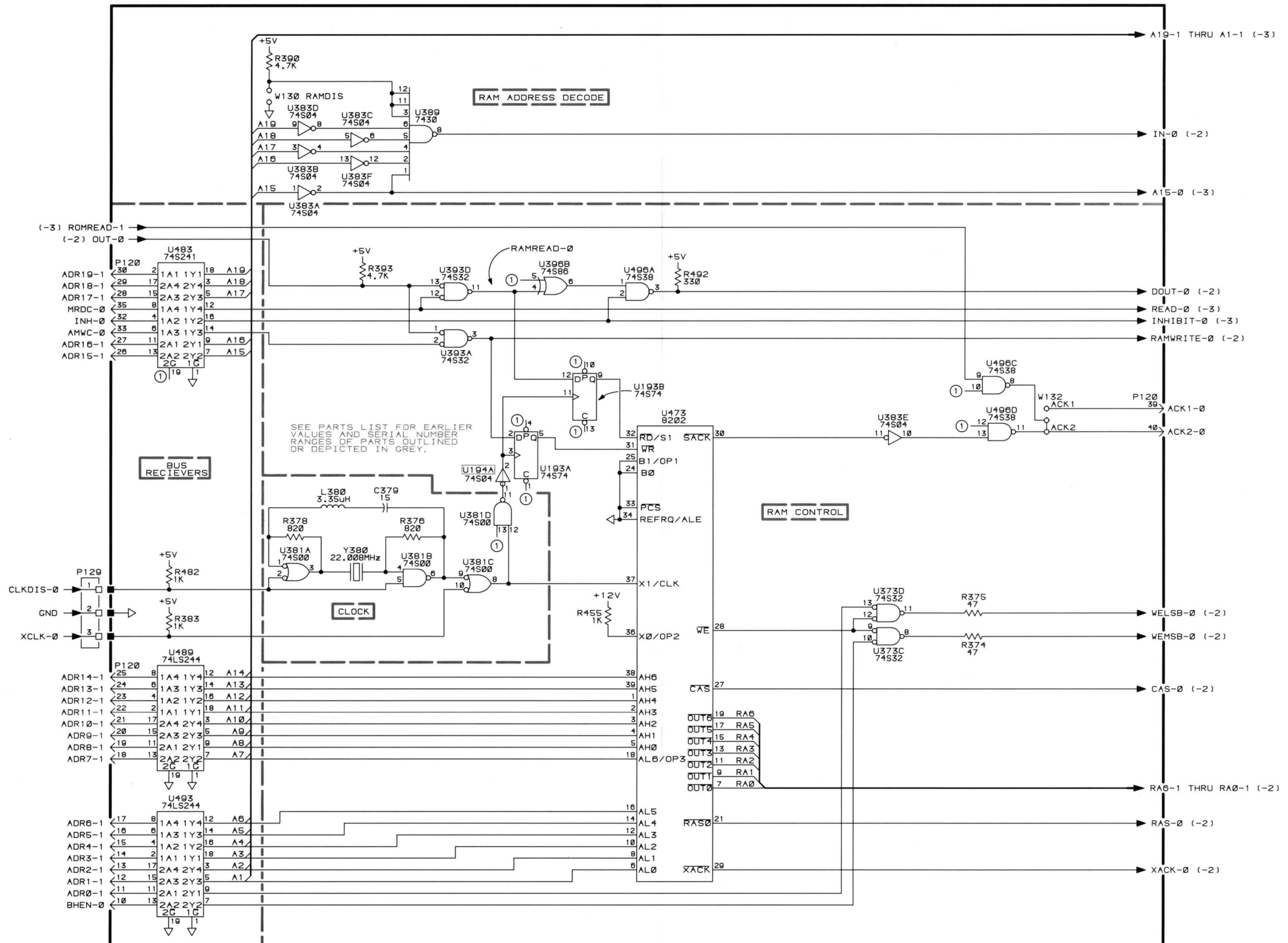

4114

REV, AUG 1981
3818-12

672-0950-00 .01 RAM/ROM BD. A5A1-1
670-0940-00 .01 (1 OF 3)

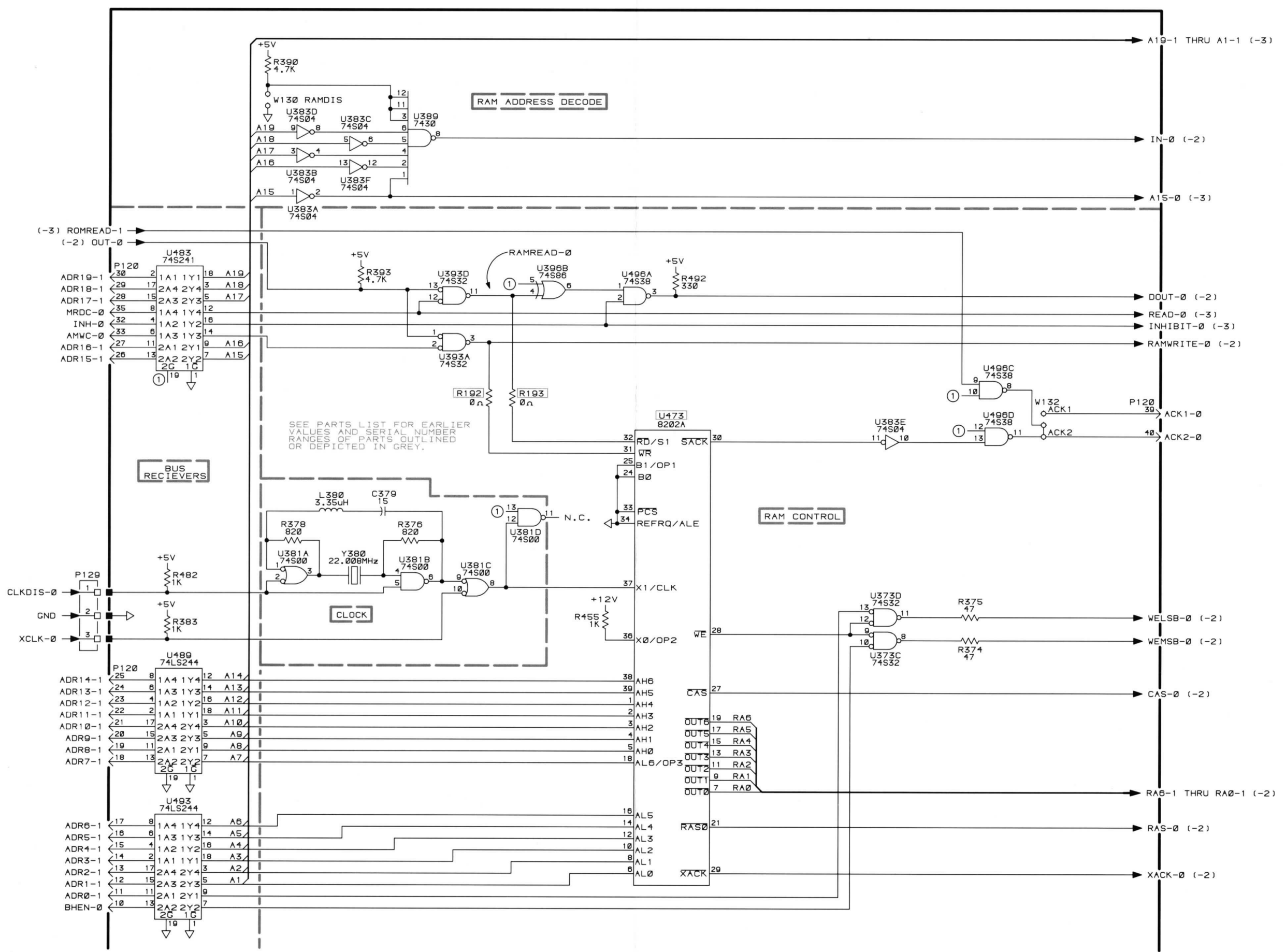

4114

3818-80

672-0950-02
670-0940-02 RAM/ROM BD. A5A1-1A
(1 OF 3)

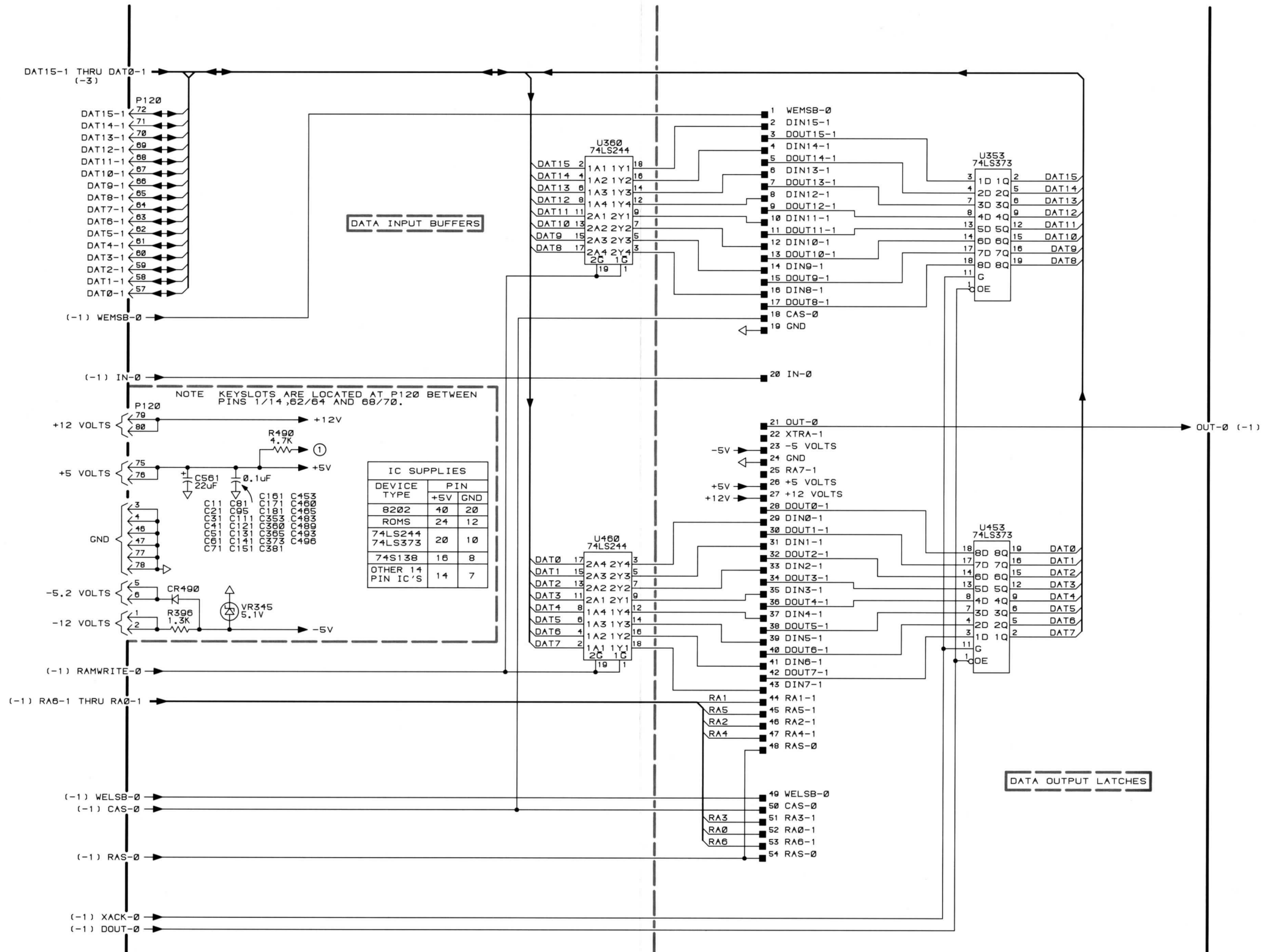

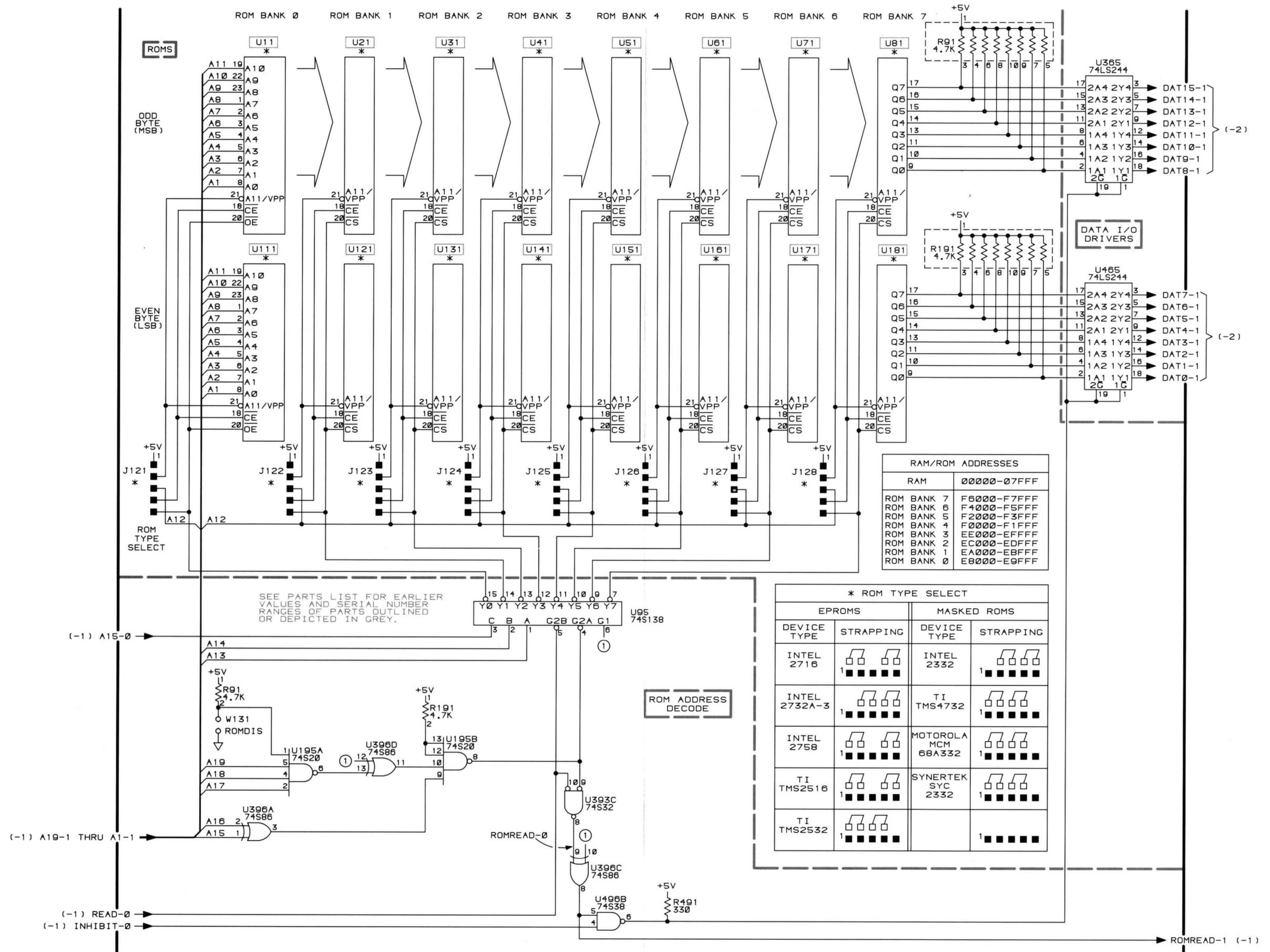

RAM/ROM ADDRESSES

RAM	ROM BANK	ADDRESS RANGE
		00000-07FFF
	ROM BANK 7	F6000-F7FFF
	ROM BANK 6	F4000-F5FFF
	ROM BANK 5	F2000-F3FFF
	ROM BANK 4	F0000-F1FFF
	ROM BANK 3	EE000-EFFFF
	ROM BANK 2	EC000-EDFFF
	ROM BANK 1	EA000-EBFFF
	ROM BANK 0	E8000-E9FFF

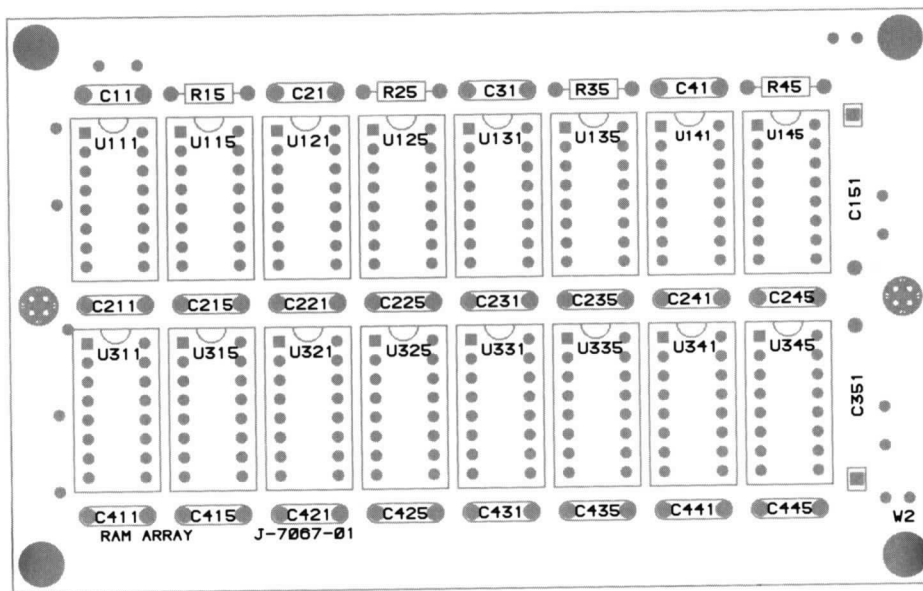

3818-94

RAM Array (670-6670-00) Component Locations.

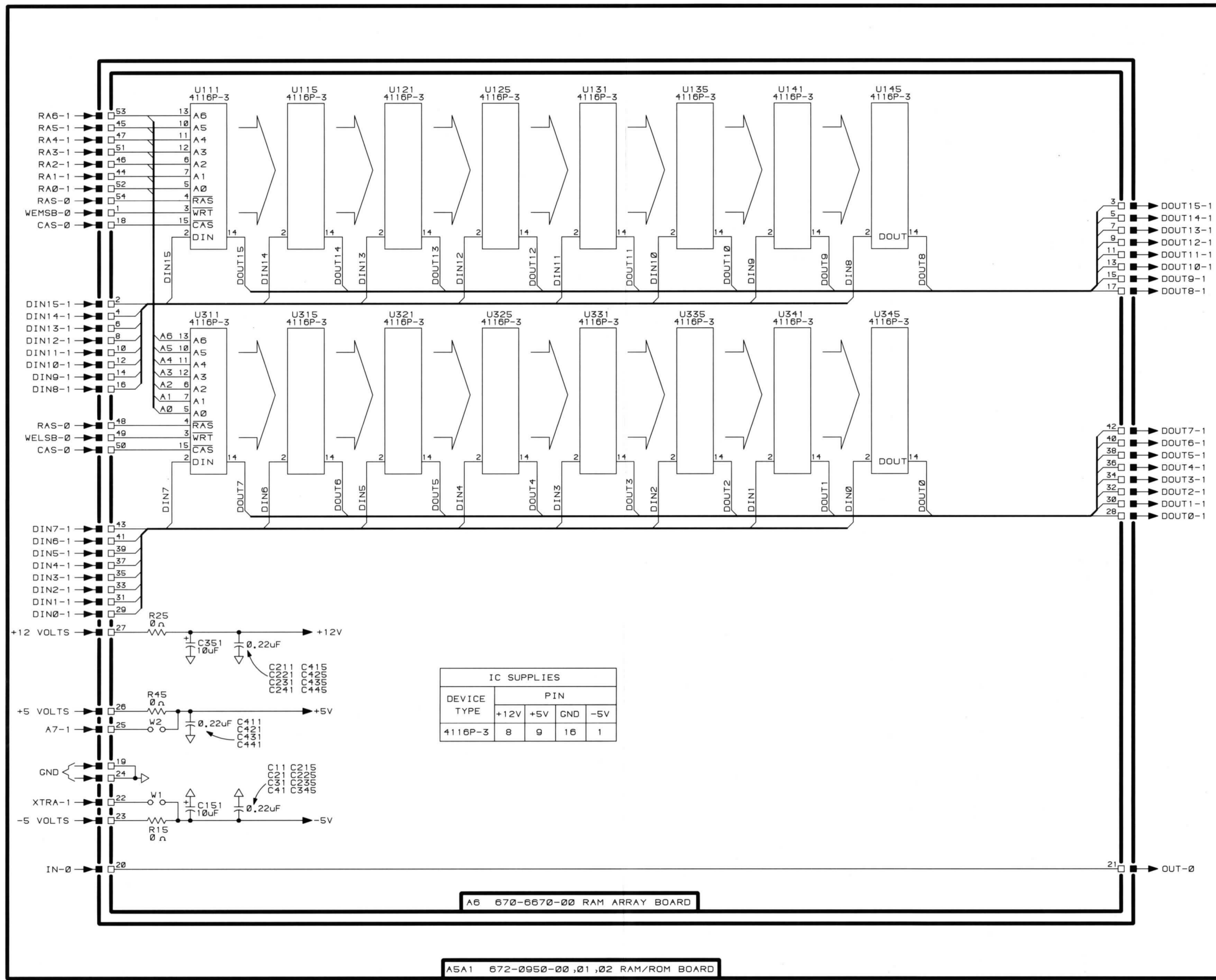

IC SUPPLIES				
DEVICE TYPE	PIN			
	+12V	+5V	GND	-5V
4116P-3	8	9	16	1

A6 670-6670-00 RAM ARRAY BOARD

ASA1 672-0950-00 ,01 ,02 RAM/ROM BOARD

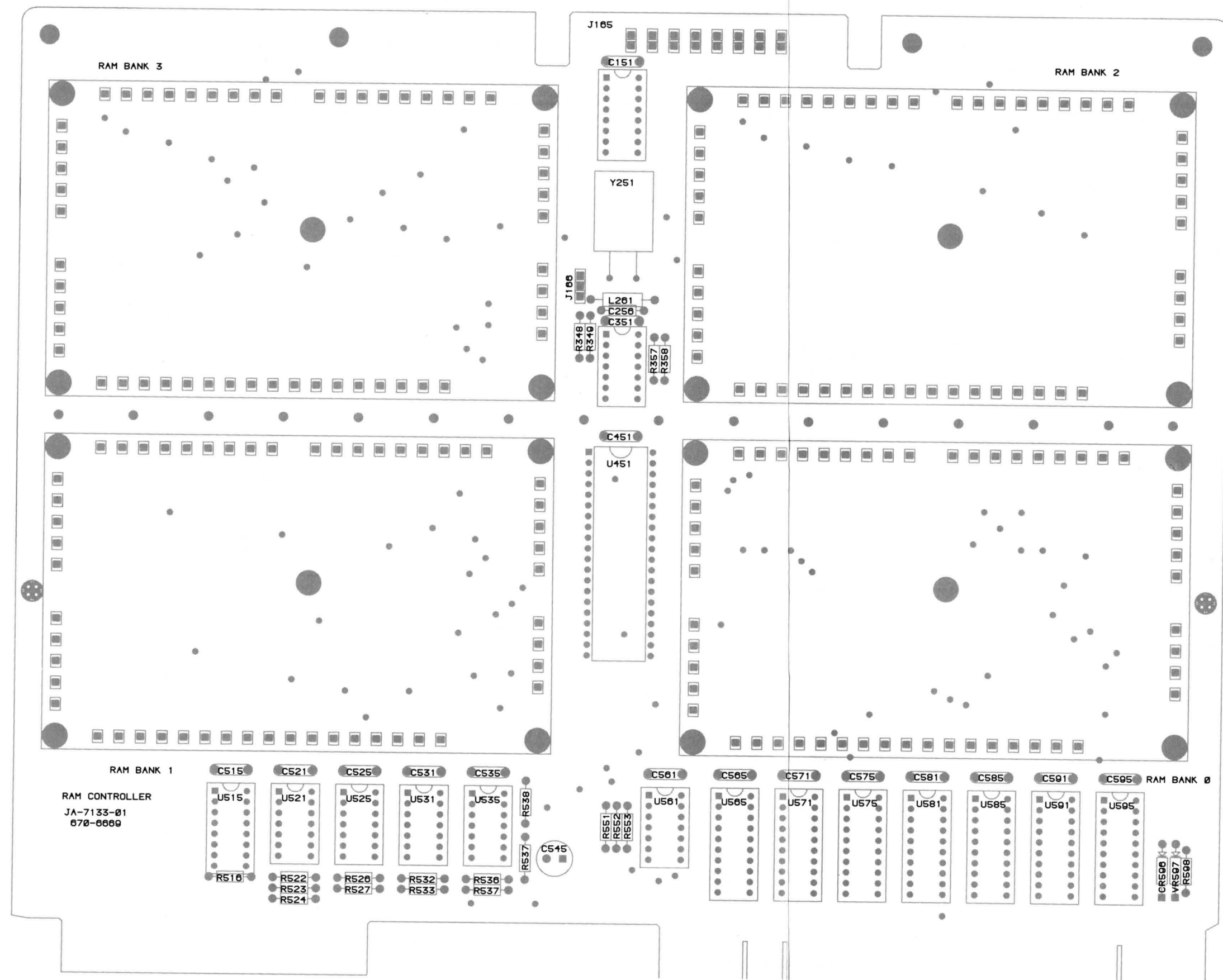

3818-95

RAM Controller (670-6669-00,01,02) Component Locations.

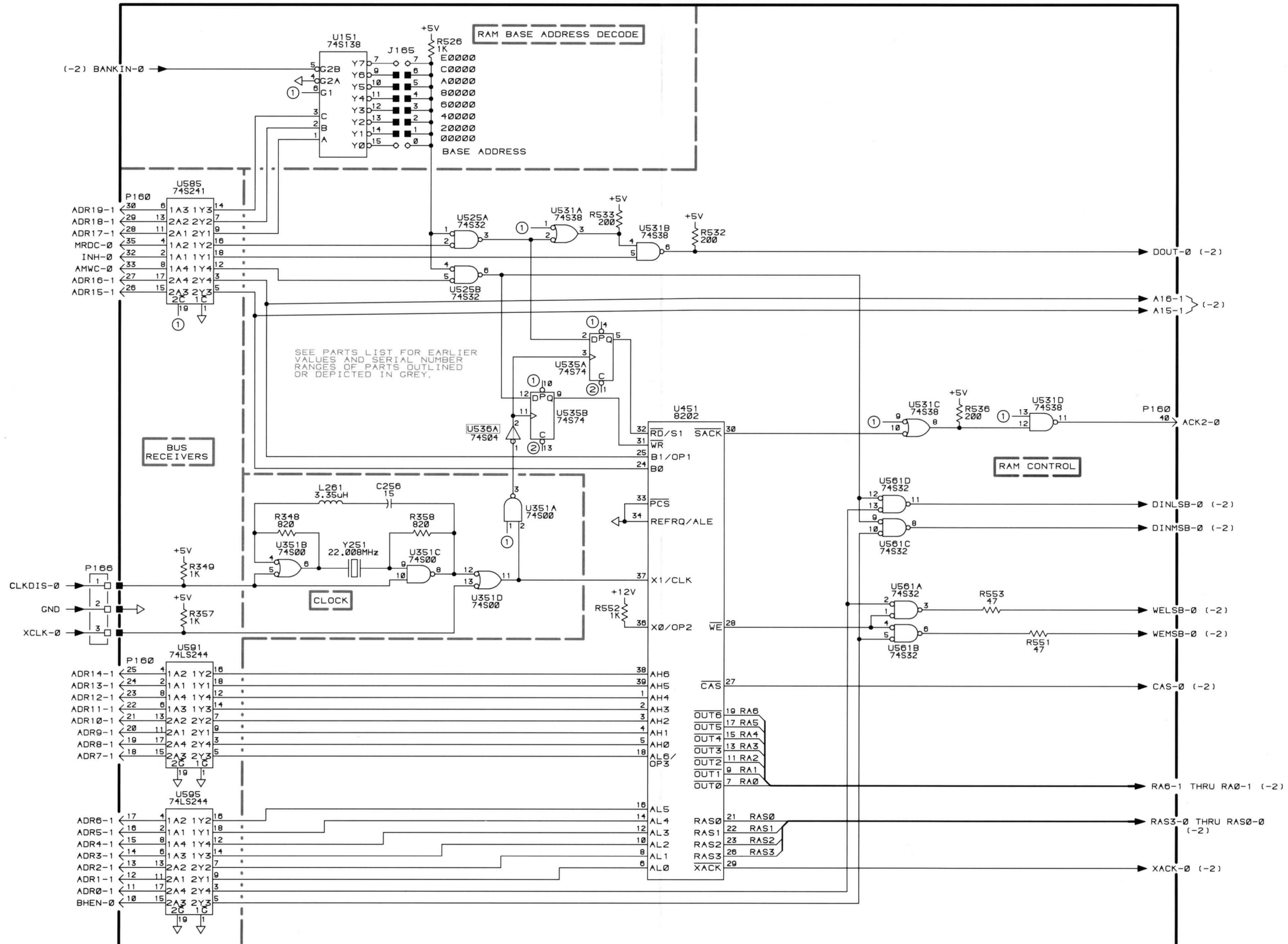

4114 OPT. 24 thru 29

REV. AUG 1981
3818-17

670-6669-00.01 RAM CONTROLLER BD. A7-1
(1 OF 2)

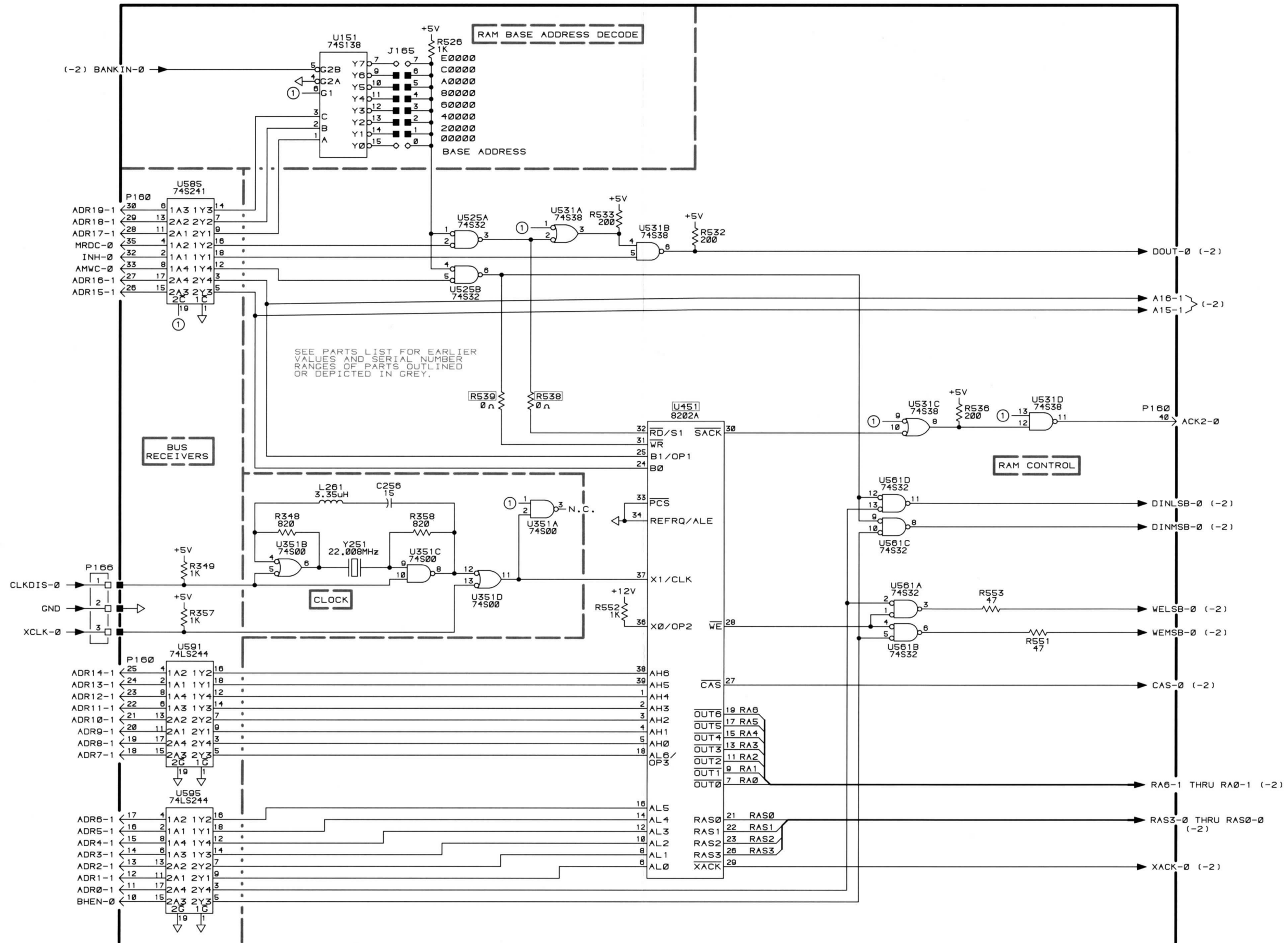

4114 OPT. 24 thru 29

3818-81

670-6669-02 RAM CONTROLLER BD. A7-1A (1 OF 2)

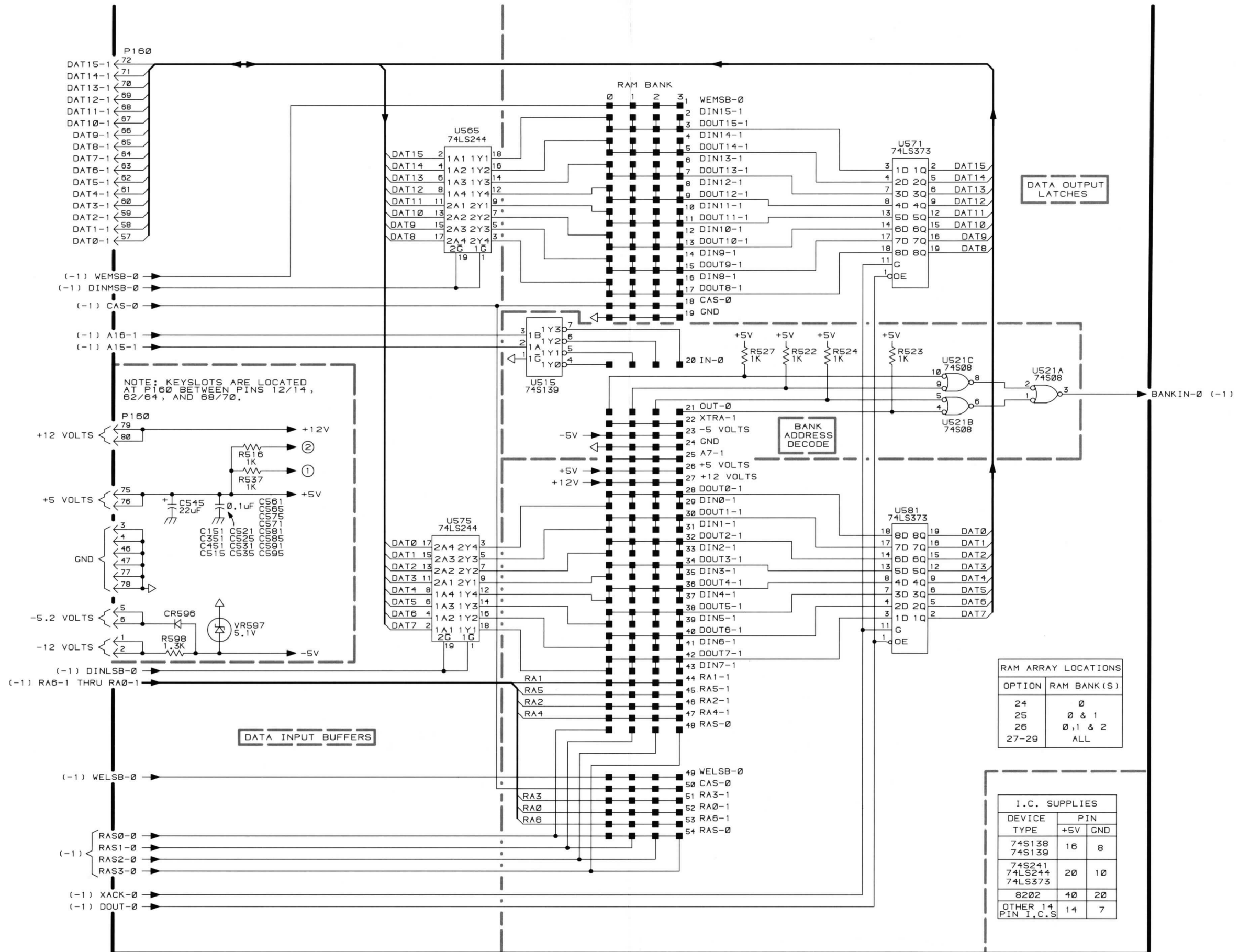

4114 OPT.24 thru 29

REV, AUG 1981
3818-18

670-6669-00,01,02 RAM CONTROLLER BD. A7-2
(2 OF 2)

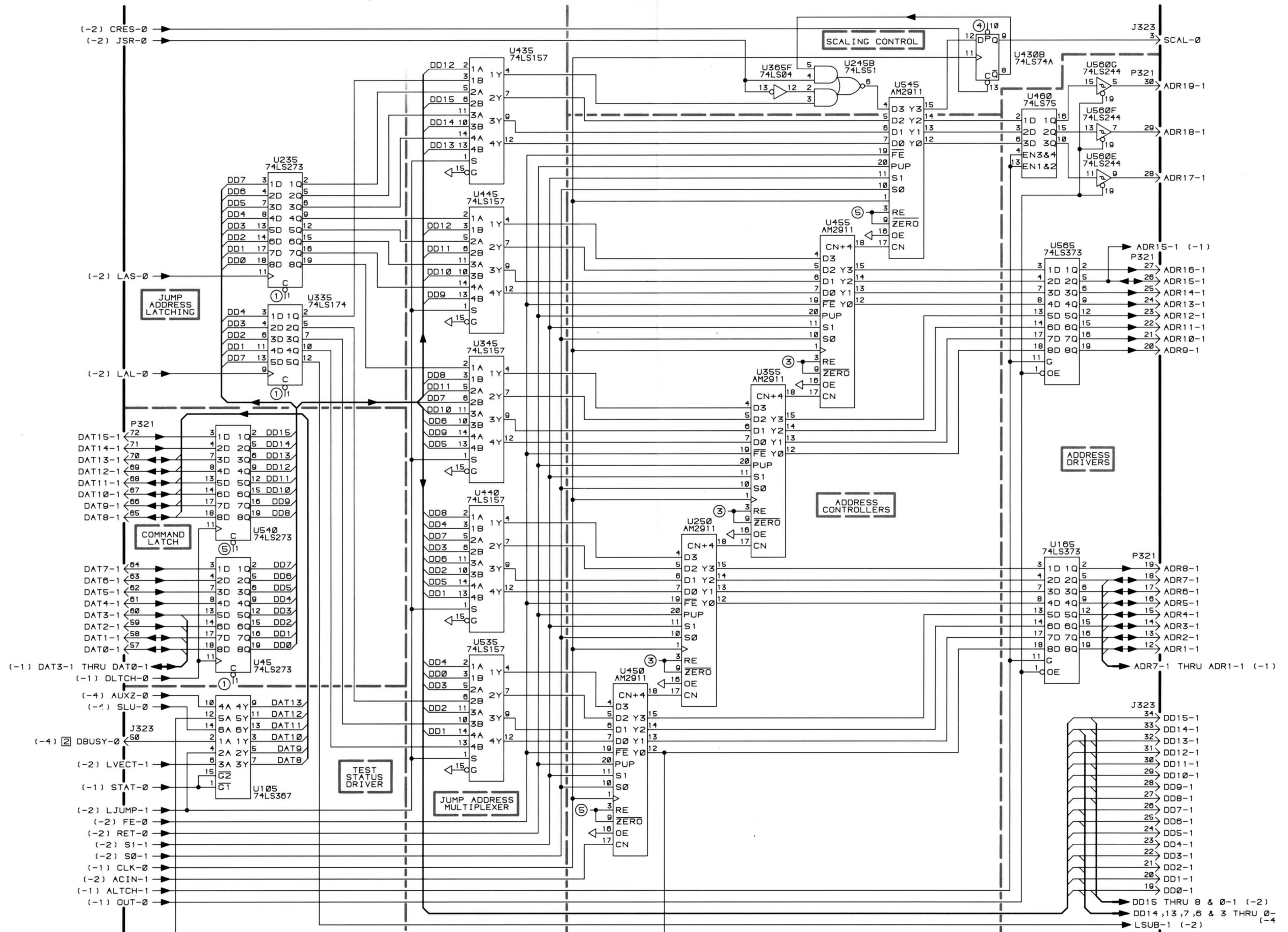

4114

□ INDICATES SHOWN MORE THAN ONCE AND WHERE (-)

REV. AUG 1981
3818-22

670-6494-02

DISPLAY CONTROLLER BD. A8-3
(3 OF 4)

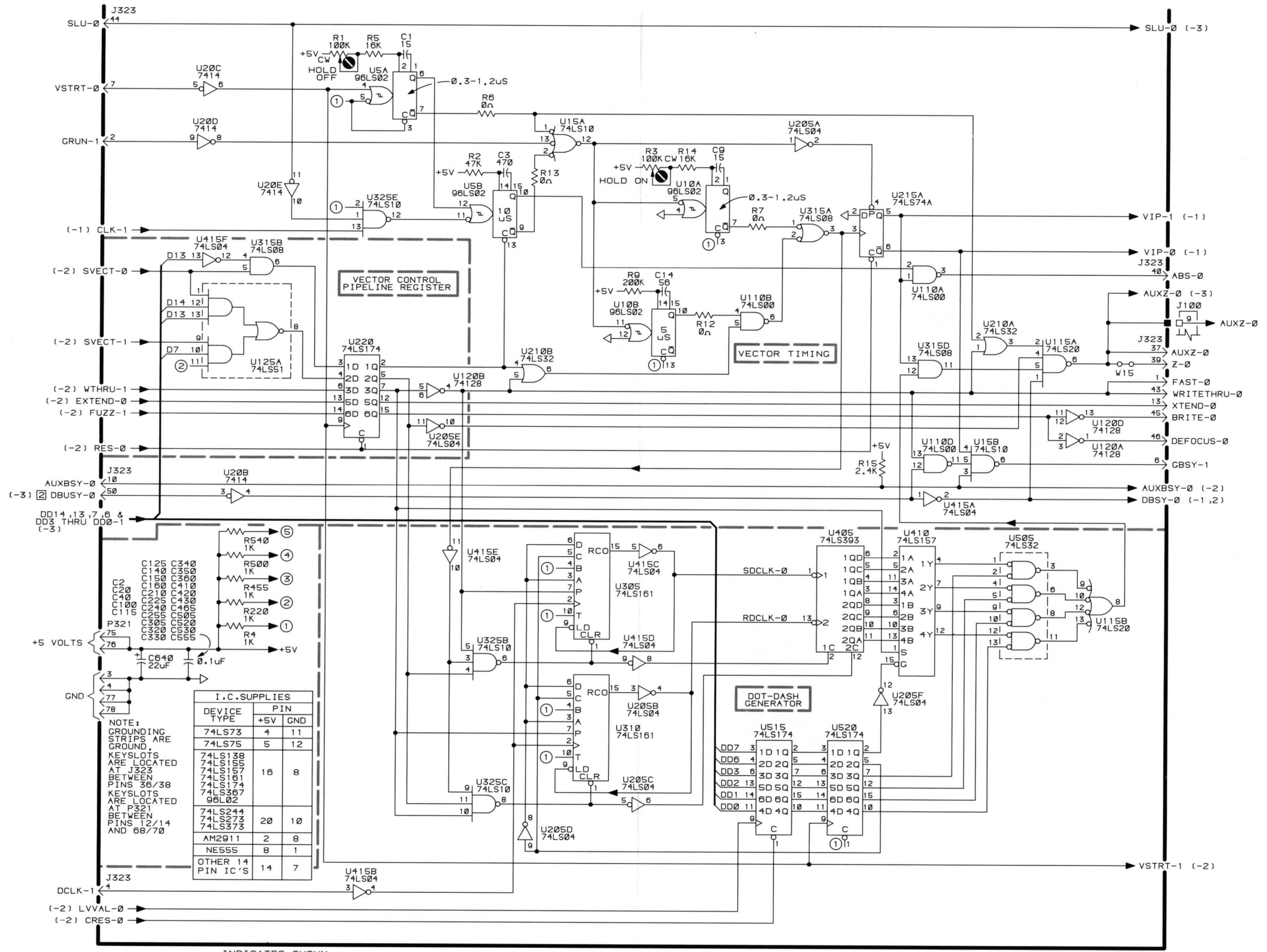

I.C. SUPPLIES		
DEVICE TYPE	+5V	GND
74LS73	4	11
74LS75	5	12
74LS138	16	8
74LS159	16	8
74LS161	16	8
74LS174	16	8
74LS367	16	8
96LS02	16	8
74LS244	20	10
74LS273	20	10
74LS373	20	10
AM2911	2	8
NESS5	8	1
OTHER 14 PIN IC'S	14	7

4114

INDICATES SHOWN MORE THAN ONCE AND WHERE (-)

REV, AUG 1981
3818-23

670-6494-02 DISPLAY CONTROLLER BD. A8-4
(4 OF 4)

VECTOR GENERATOR
COMPONENT LOCATIONS

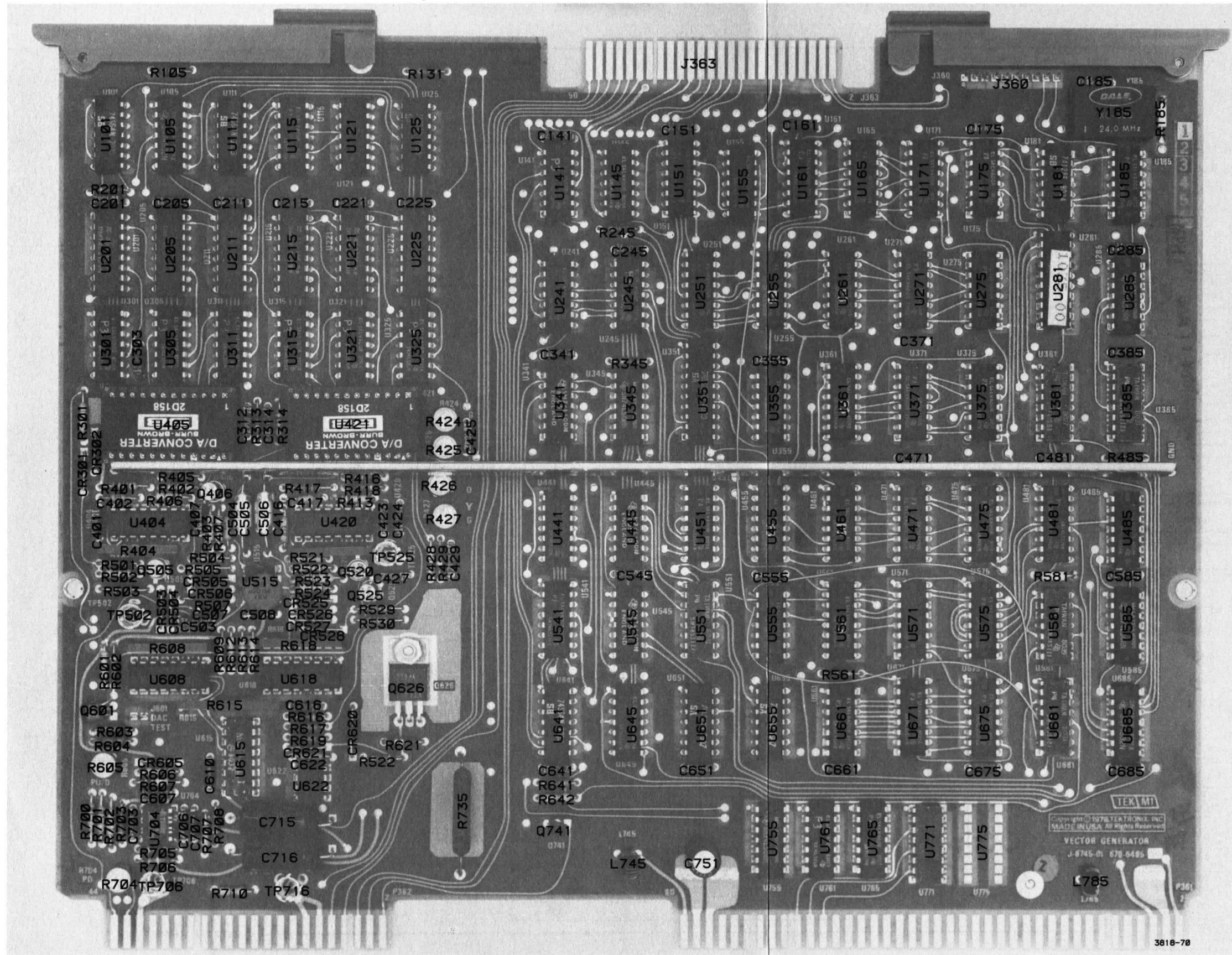

3818-70

Vector Generator (670-6495-00) Component Locations.

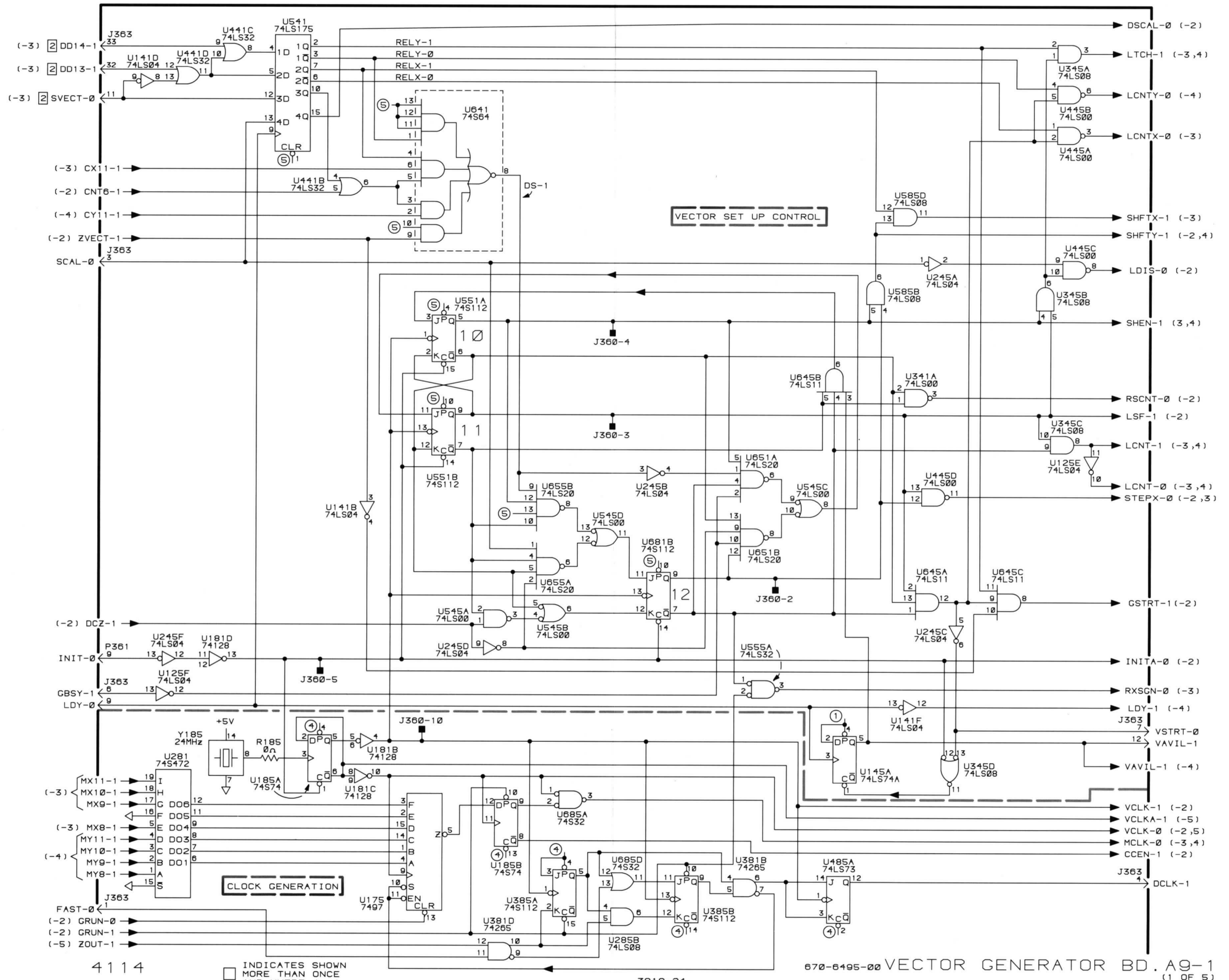

4114

□ INDICATES SHOWN MORE THAN ONCE AND WHERE (-)

3818-24

670-6495-00 VECTOR GENERATOR BD.A9-1 (1 OF 5)

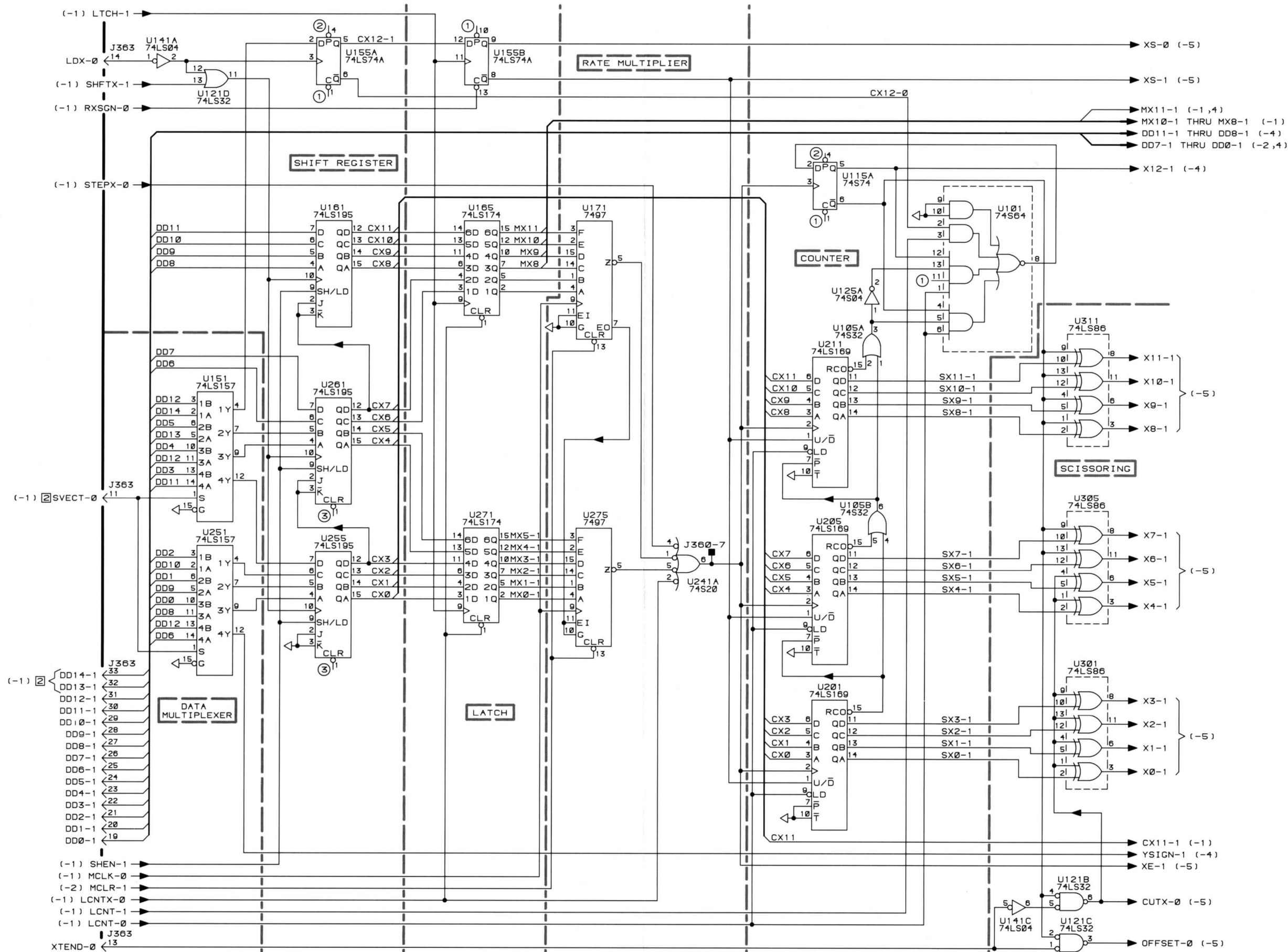

4 1 1 4

INDICATES SHOWN MORE THAN ONCE AND WHERE (-)

3818-26

670-6495-00 VECTOR GENERATOR BD A9-3 X DATA HANDLER (3 OF 5)

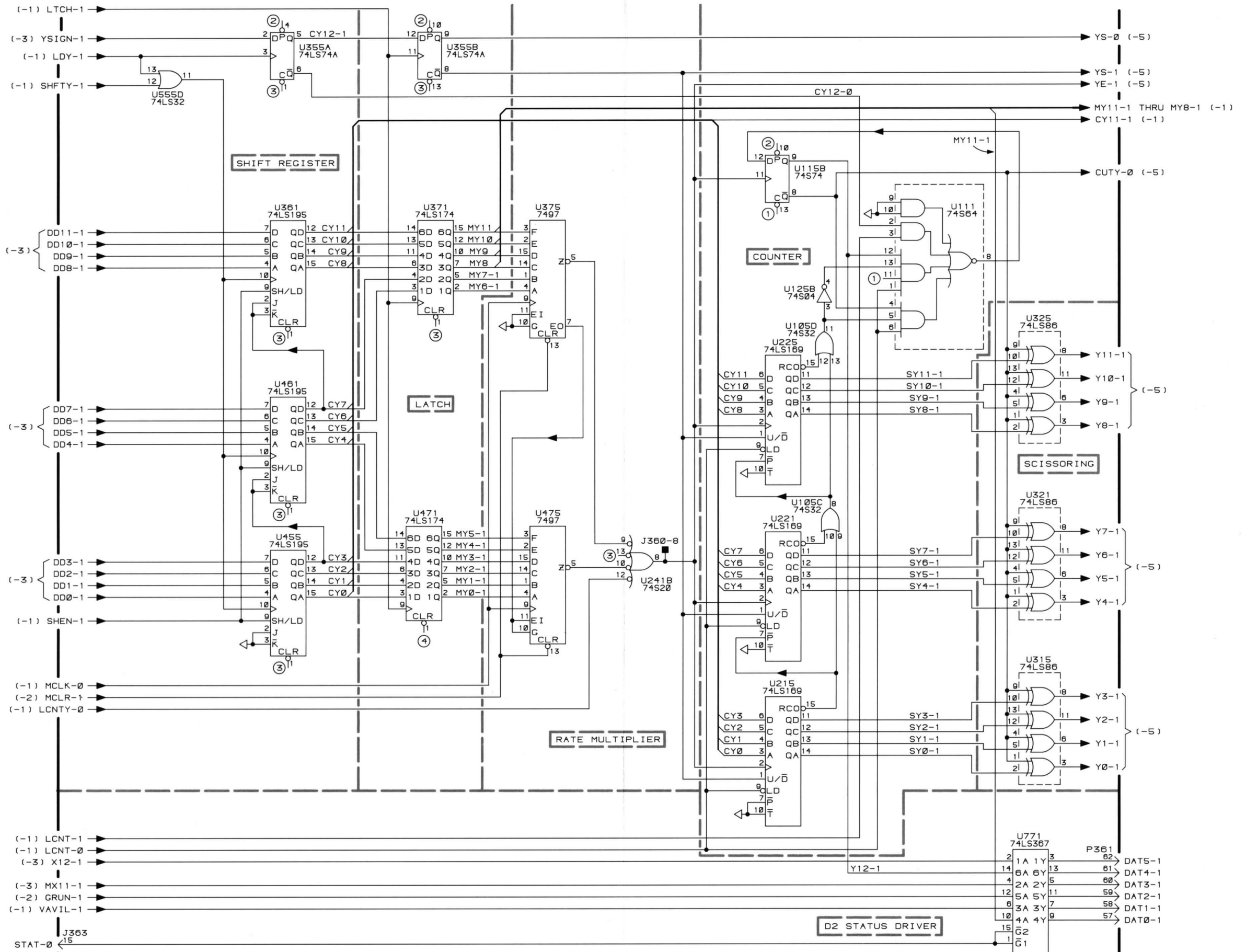

4114

3818-27

670-6495-00 VECTOR GENERATOR BD. A9-4
Y DATA HANDLER (4 OF 5)

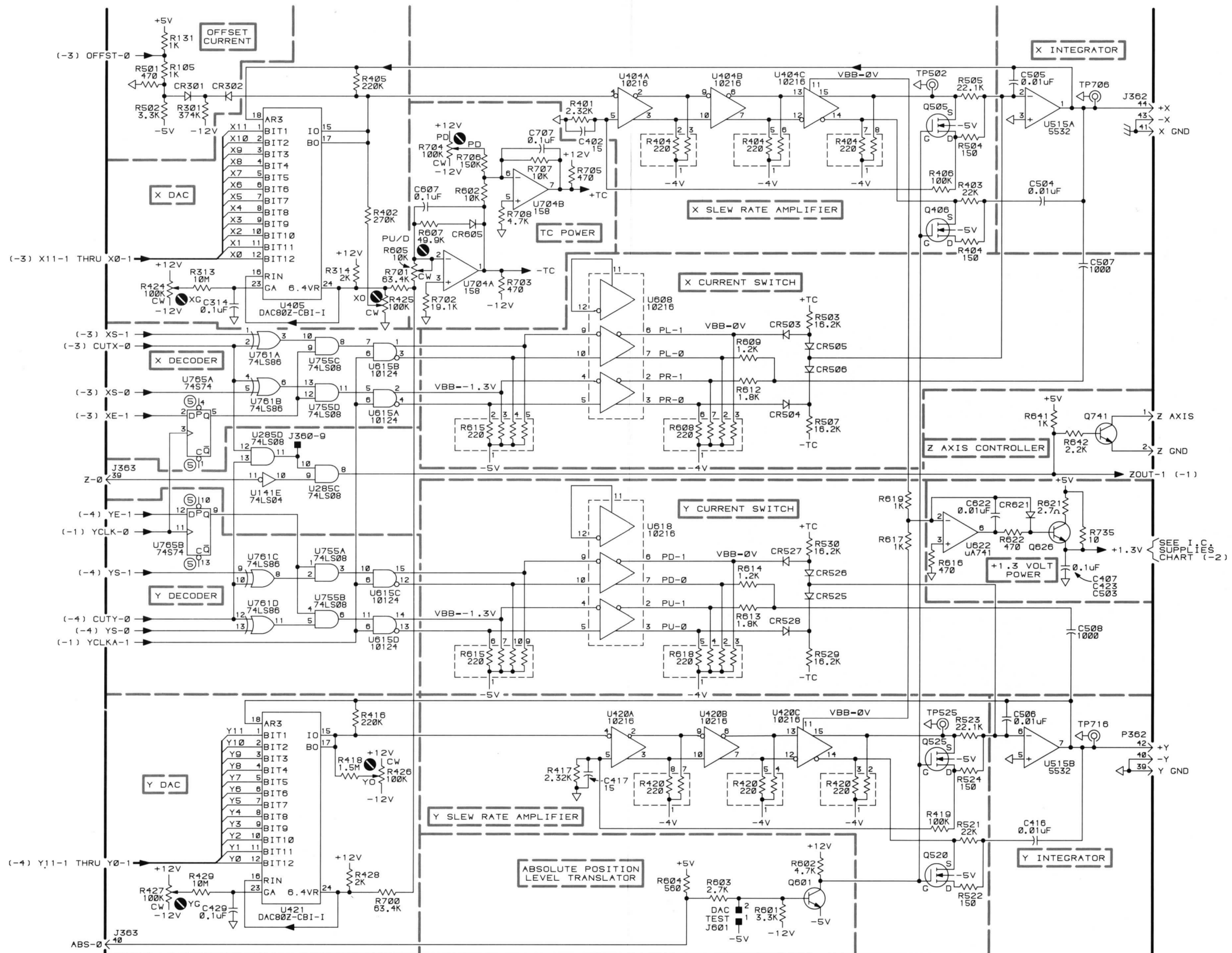

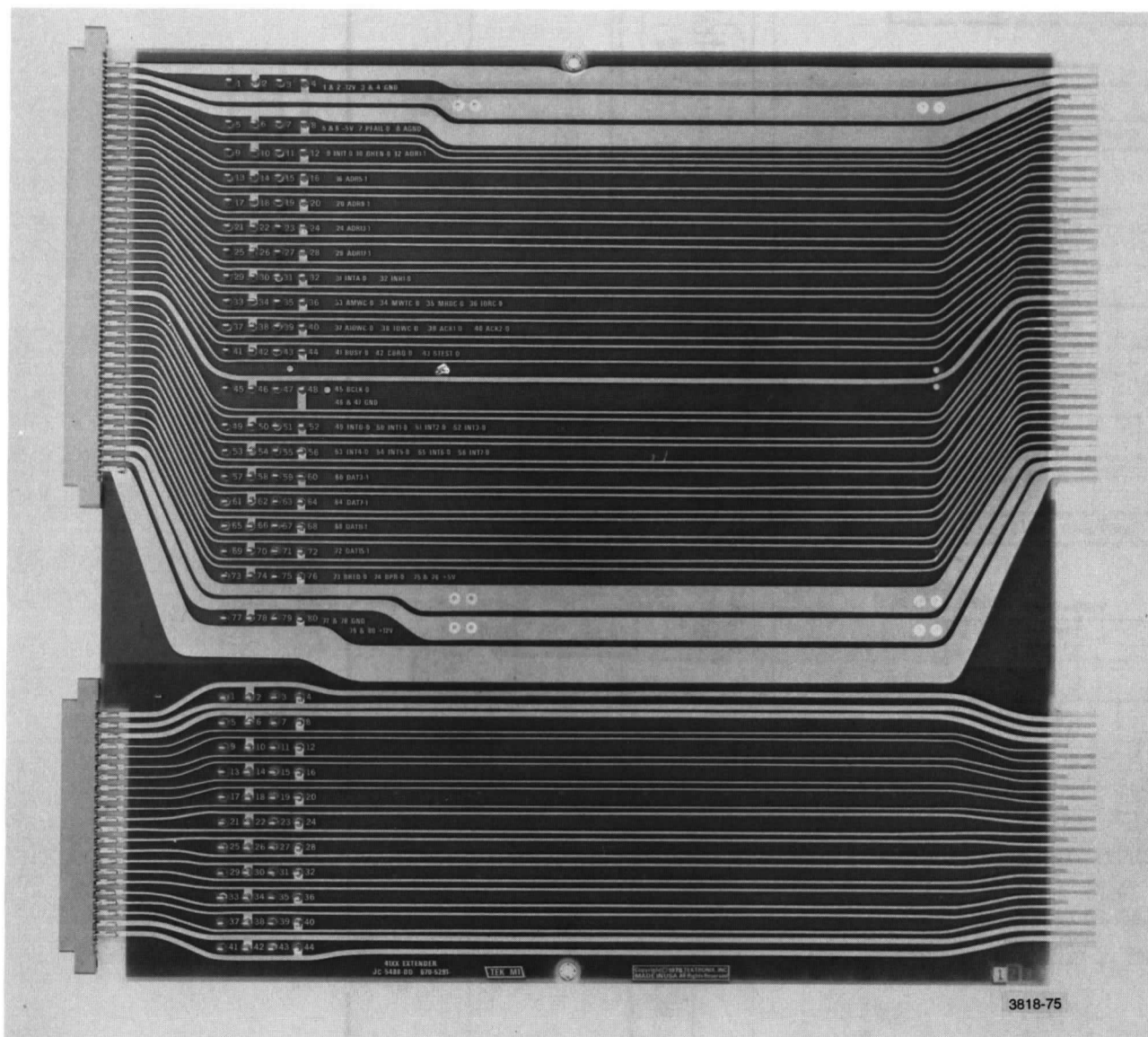

41XX Logic Extender (670-5291-00) Component Locations.

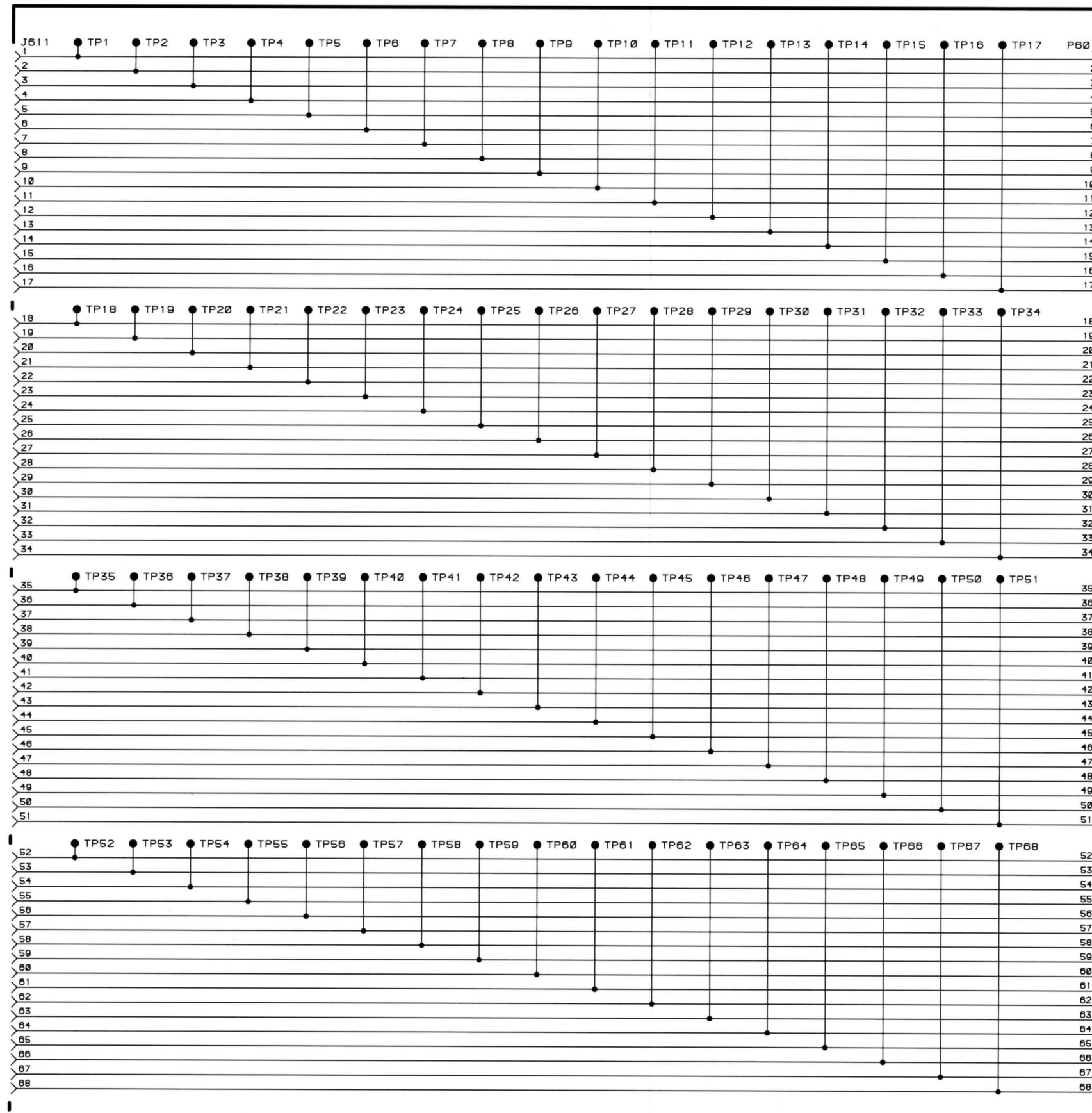

J1 THRU J15

- 12 VOLTS
- 12 VOLTS
- GND
- GND
- 5.2 VOLTS
- 5.2 VOLTS
- PFAIL-0
- AGND
- INIT-0
- BHEN-0
- ADR0-1
- ADR1-1
- ADR2-1
- ADR3-1
- ADR4-1
- ADR5-1
- ADR6-1
- ADR7-1
- ADR8-1
- ADR9-1
- ADR10-1
- ADR11-1
- ADR12-1
- ADR13-1
- ADR14-1
- ADR15-1
- ADR16-1
- ADR17-1
- ADR18-1
- ADR19-1
- INTA-0
- INH-0
- AMWC-0
- MWTC-0
- MRDC-0
- IORC-0
- AIOWC-0
- IOWC-0
- ACK1-0
- ACK2-0
- BUSY-0
- CBRQ-0
- STEST-0
- SPARE
- BCLK-0
- GND
- GND
- SPARE
- INT0-0
- INT1-0
- INT2-0
- INT3-0
- INT4-0
- INT5-0
- INT6-0
- INT7-0
- DAT0-1
- DAT1-1
- DAT2-1
- DAT3-1
- DAT4-1
- DAT5-1
- DAT6-1
- DAT7-1
- DAT8-1
- DAT9-1
- DAT10-1
- DAT11-1

067-1005-00
(FOR USE WITH 4114)

3818-29

670-5291-00 41XX LOGIC EXTENDER BD.A10-1
(1 OF 2)

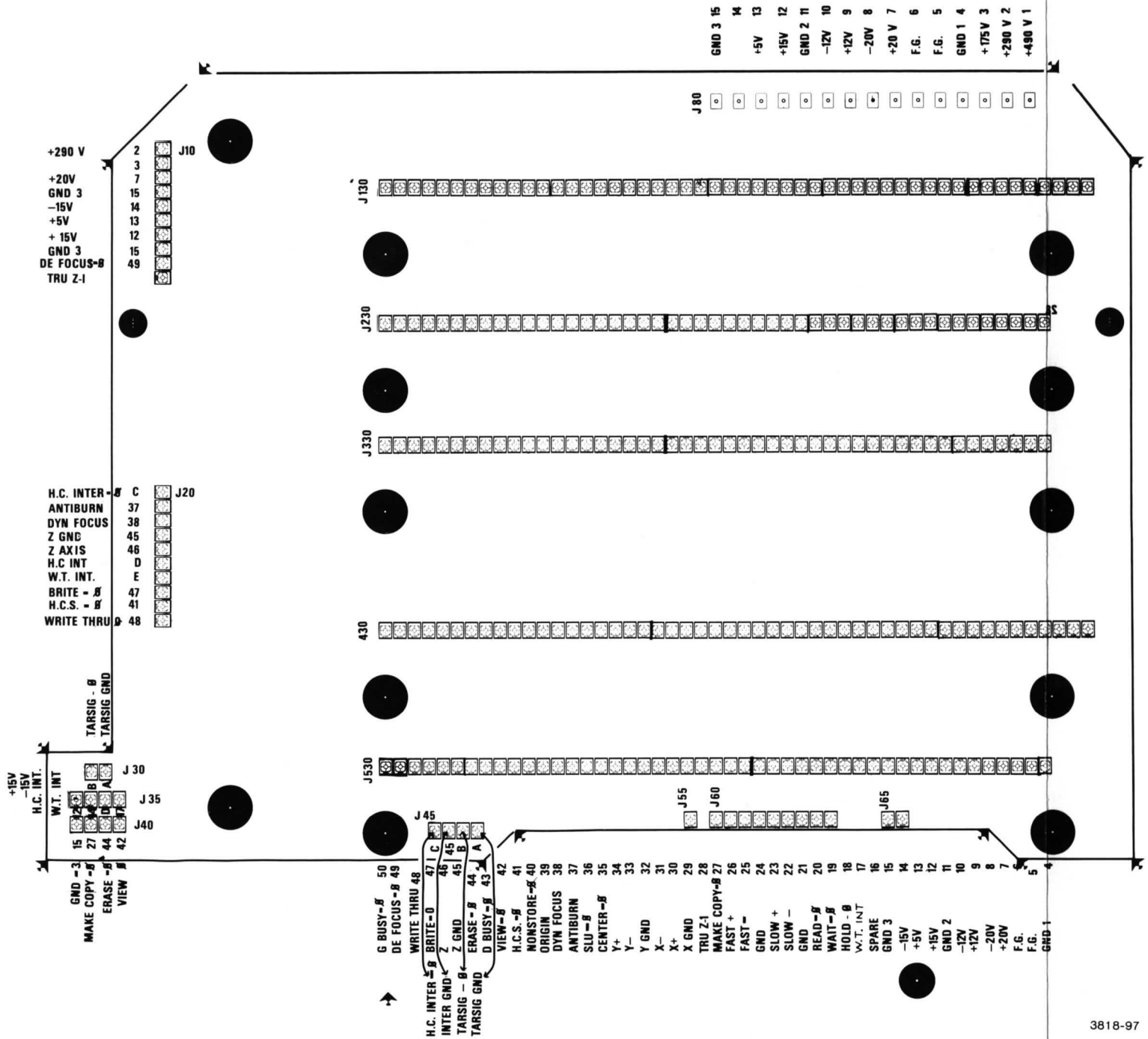

Interconnect (670-5163-01) Component Locations.

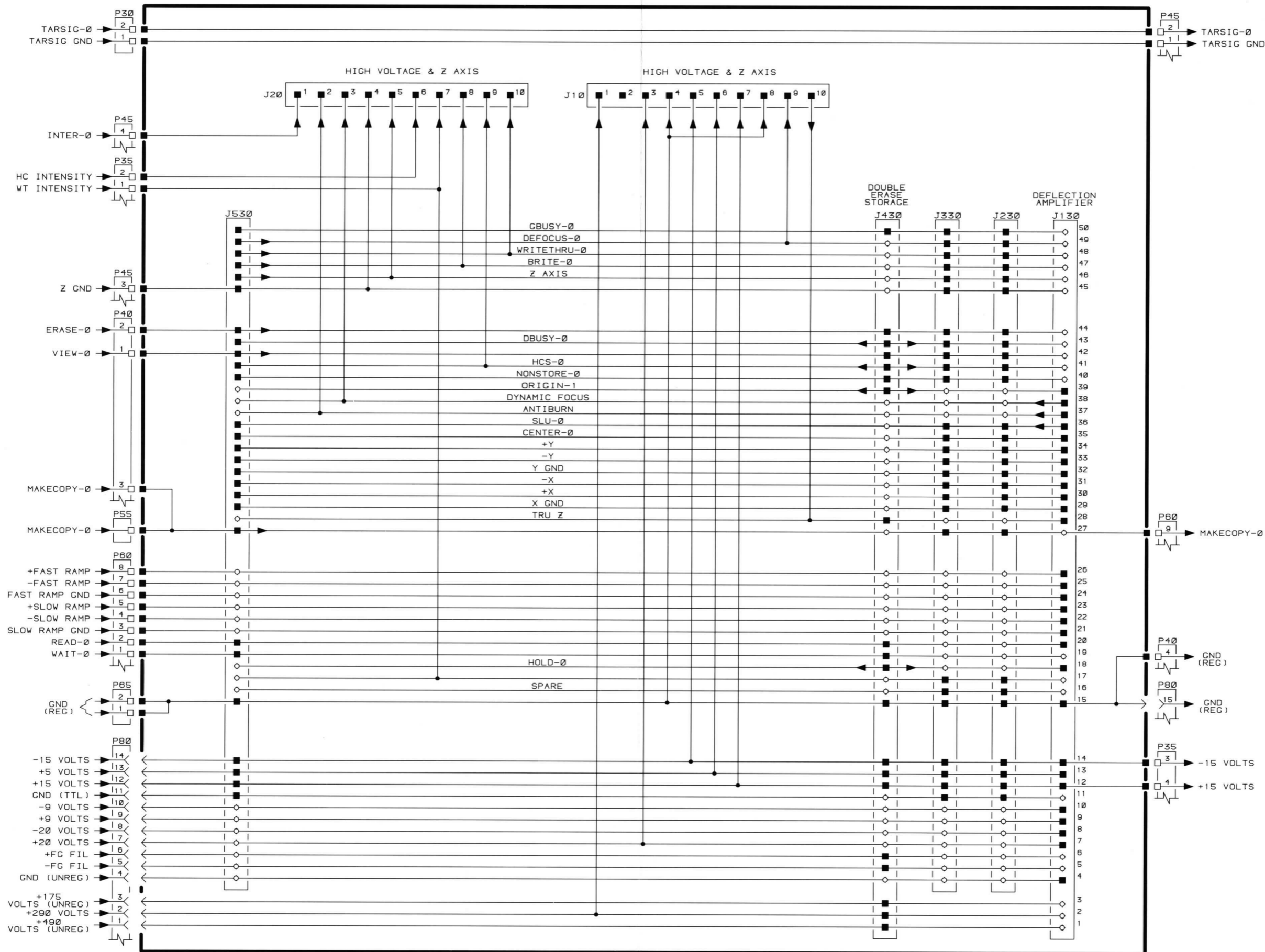

4114

REV, JUN 1982
3818-32

670-5163-01 INTERCONNECT BD.

A11-1
(1 OF 1)

INTERCONNECT
670-5163-01

A11-1

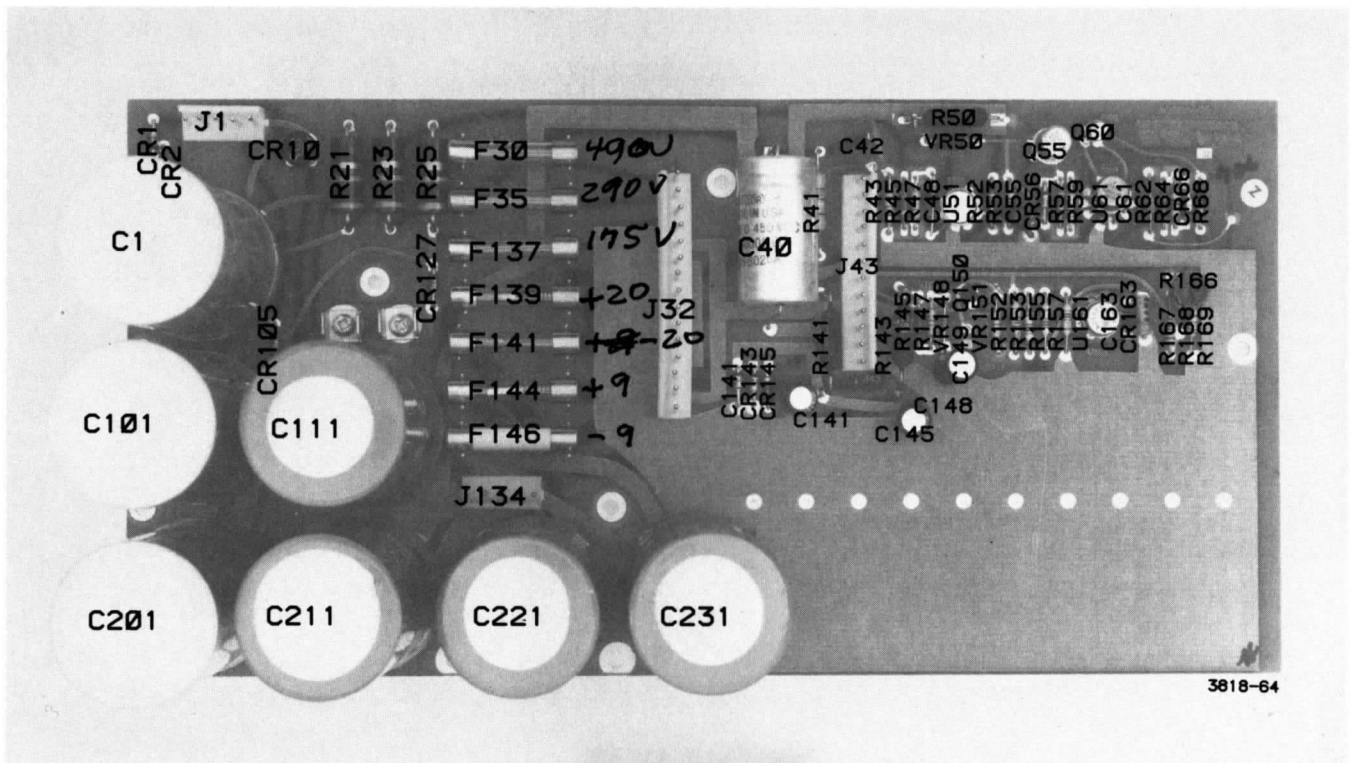

LVPS Board (670-4798-03) Component Locations.

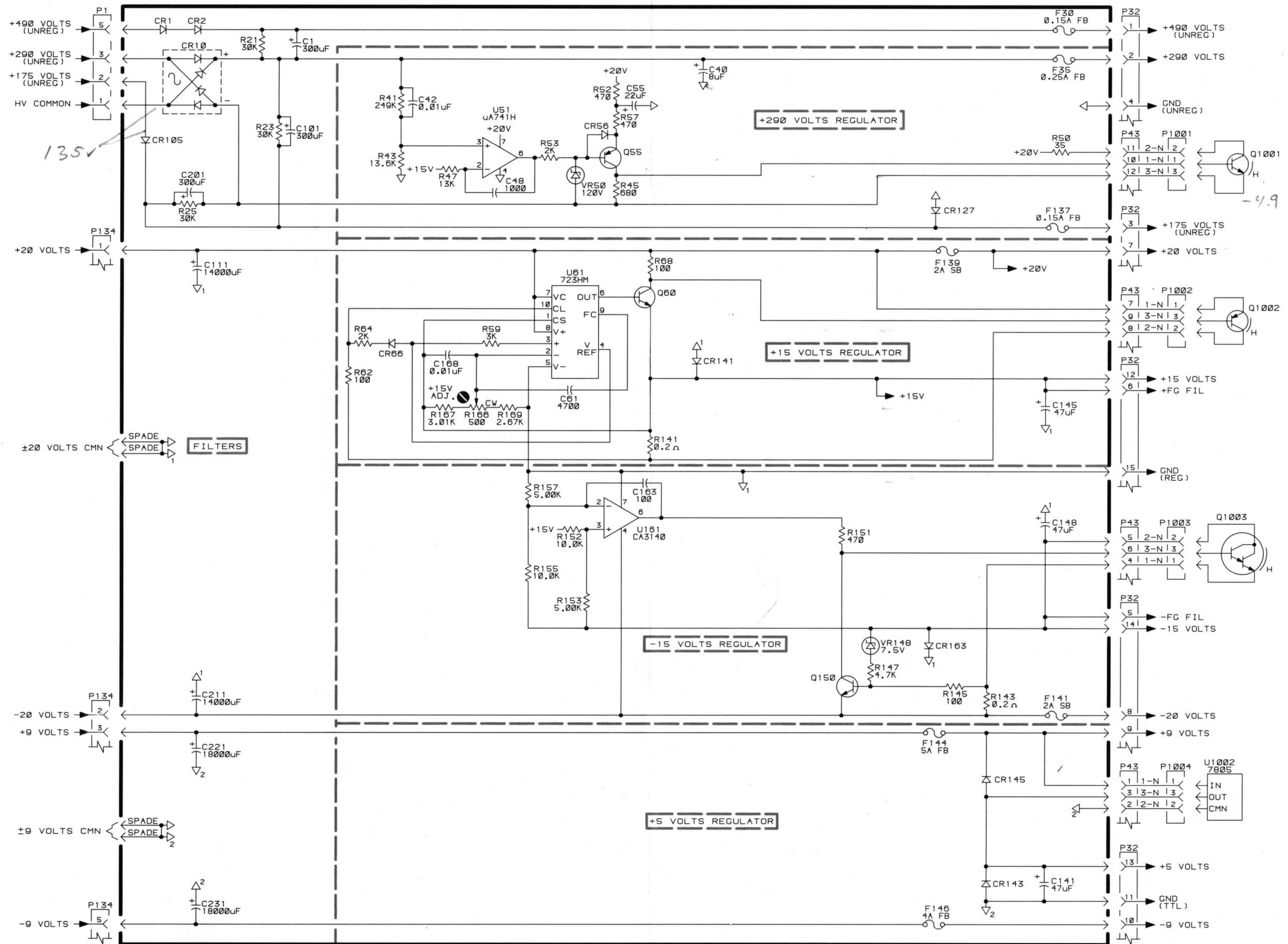

135

4114

REV, JUN 1982
3818-33

670-4798-03 LOW VOLTAGE POWER SUPPLY BD.

A12-1
(1 OF 1)

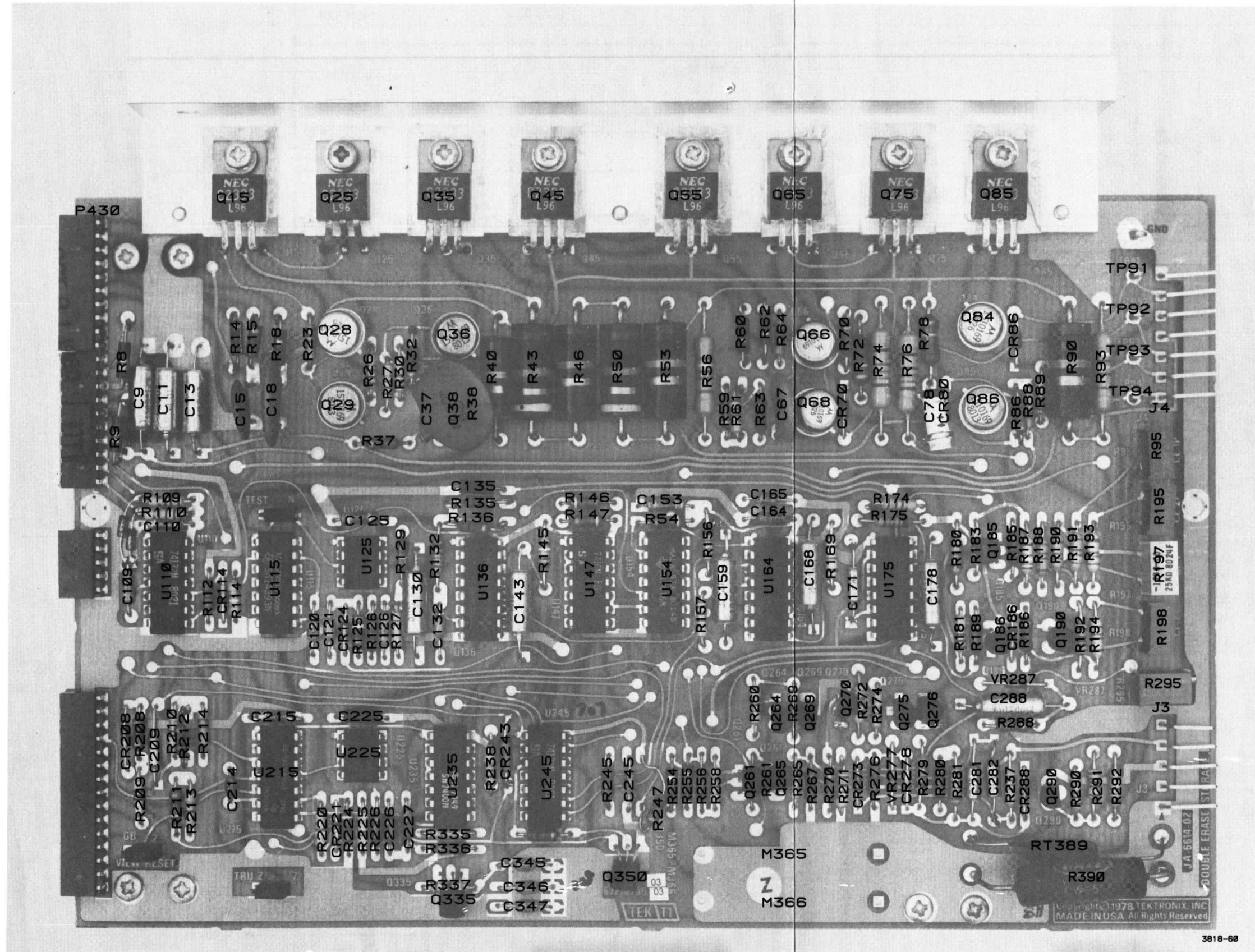

Double Erase Storage (672-0795-03,04) Component Locations.

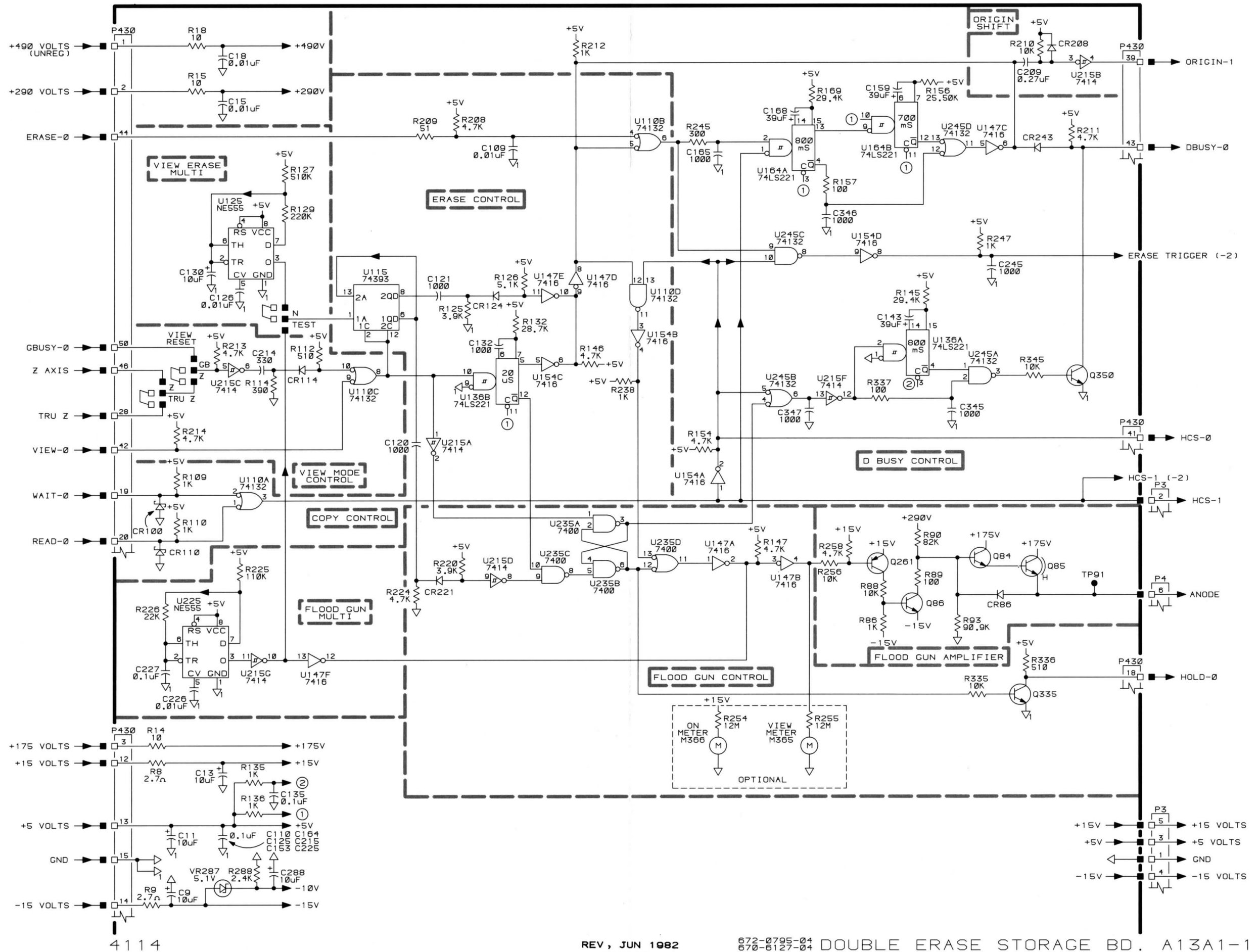

4114

REV, JUN 1982
3818-35

672-0795-04
670-6127-04 DOUBLE ERASE STORAGE BD. A13A1-1
(1 OF 2)

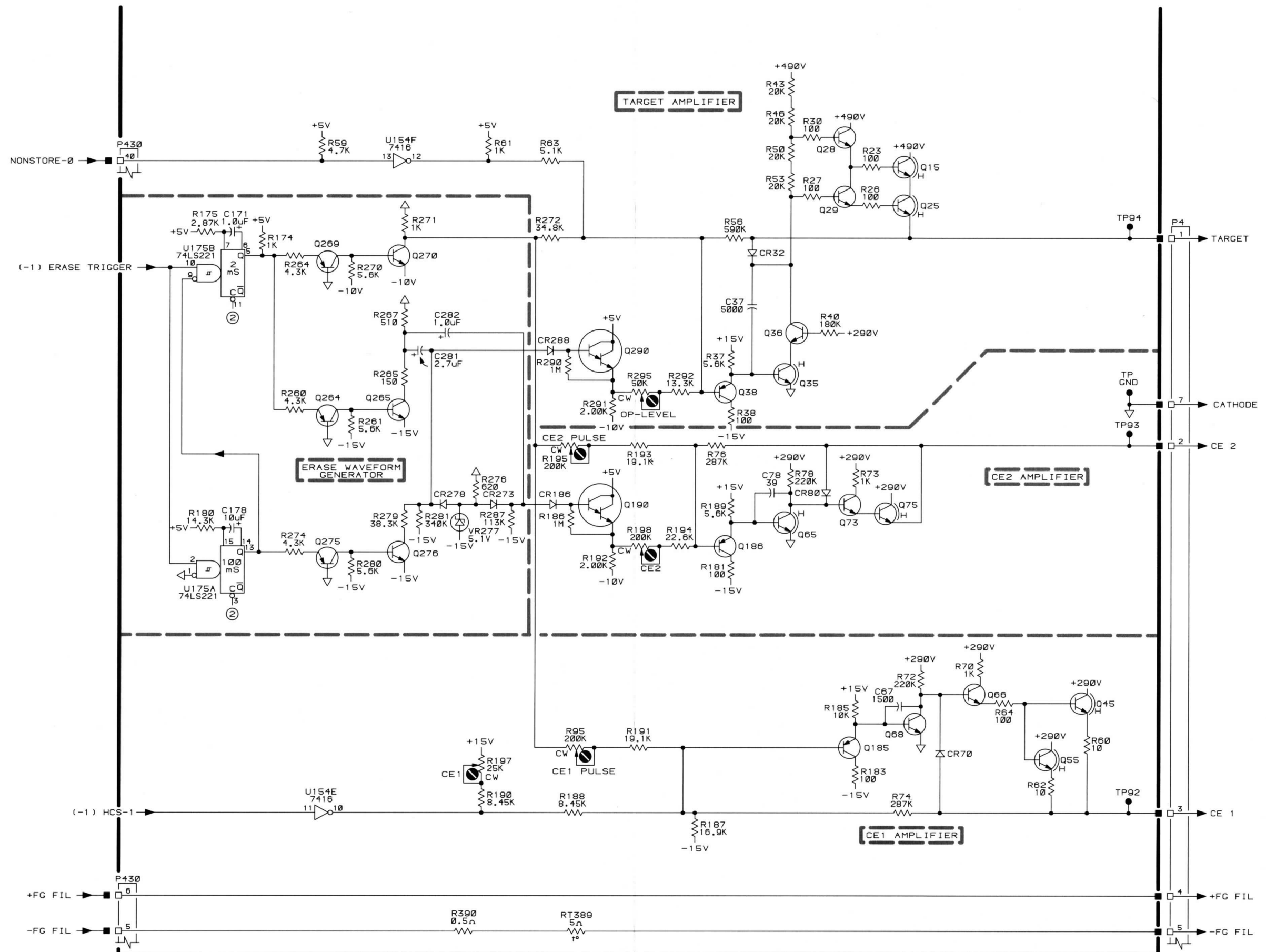

4114

REV, JUN 1982
3818-36

672-0795-04
870-6127-04
DOUBLE ERASE STORAGE BD. A13A1-2
(2 OF 2)

DOUBLE ERASE STORAGE A13A1-2
672-0795-03,04

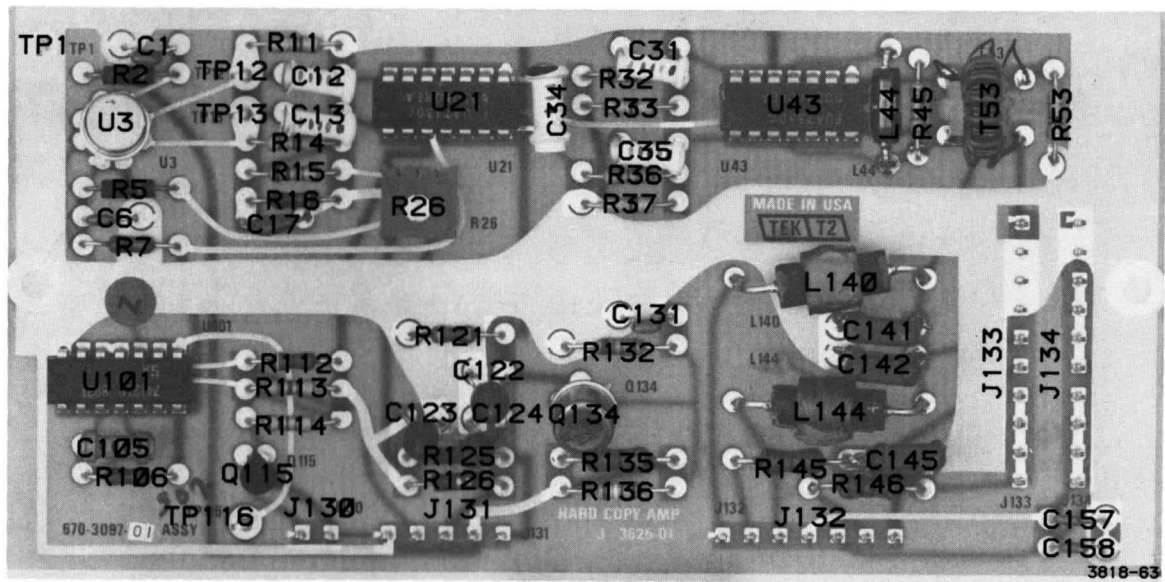

Hard Copy Amplifier (670-3097-01) Component Locations.

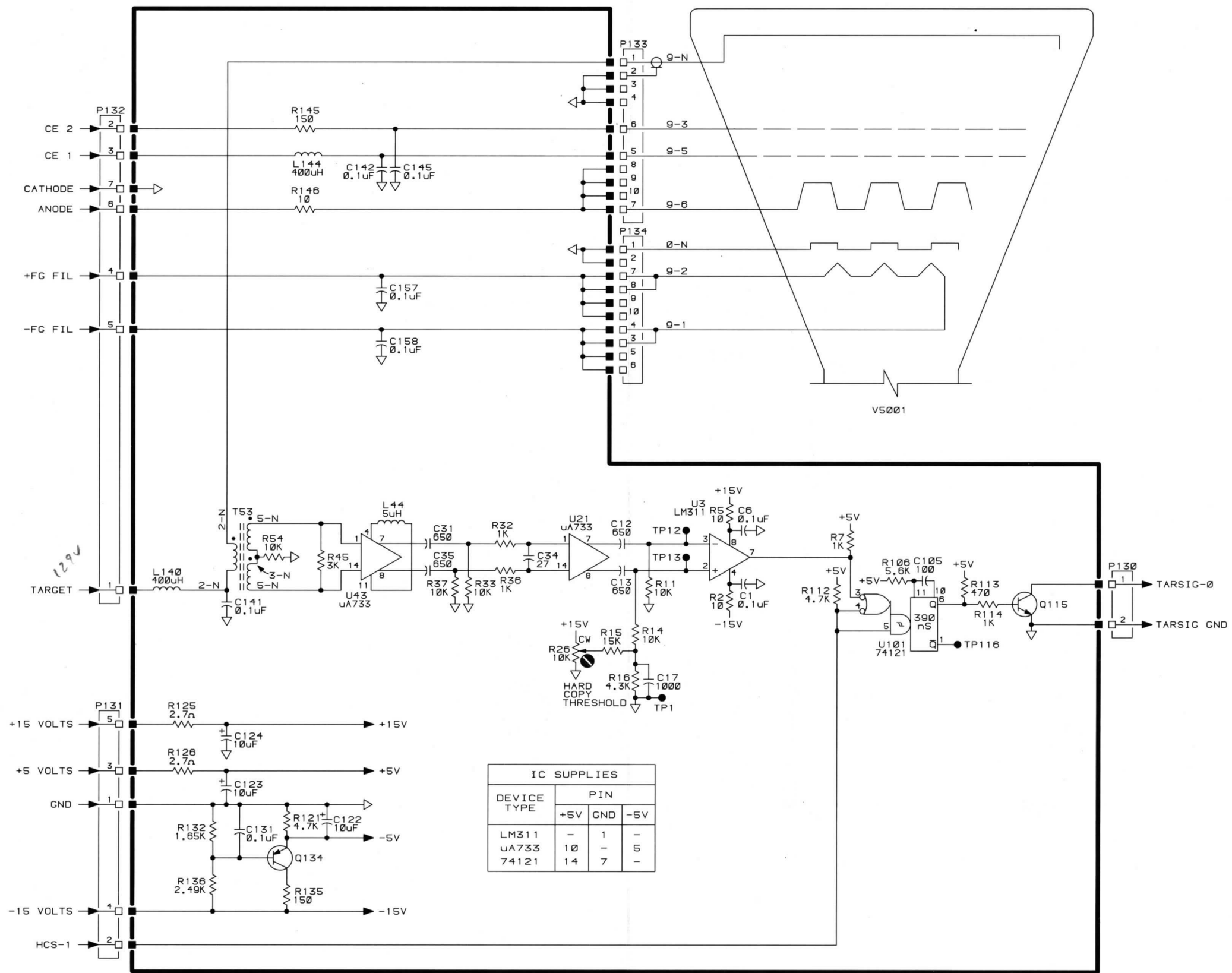

IC SUPPLIES			
DEVICE TYPE	PIN		
	+5V	GND	-5V
LM311	-	1	-
uA733	10	-	5
74121	14	7	-

4114

REV, AUG 1981.
3818-37

670-3097-01 HARD COPY AMPLIFIER BD. A14-1
(1 OF 1)

HC AMPLIFIER
670-3097-01

A14-1

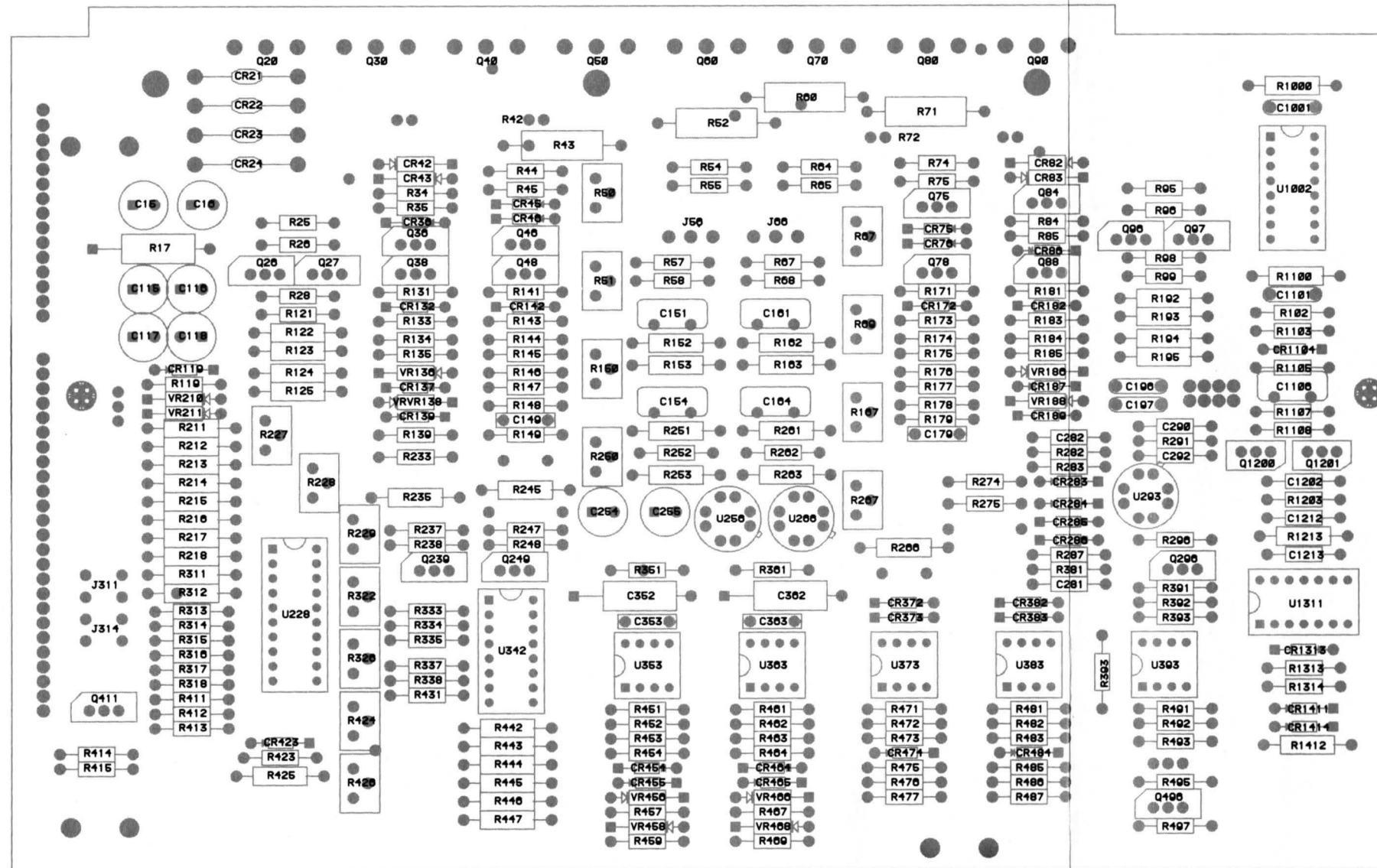

3818-98

Deflection Amplifier (672-0901-01) Component Locations.

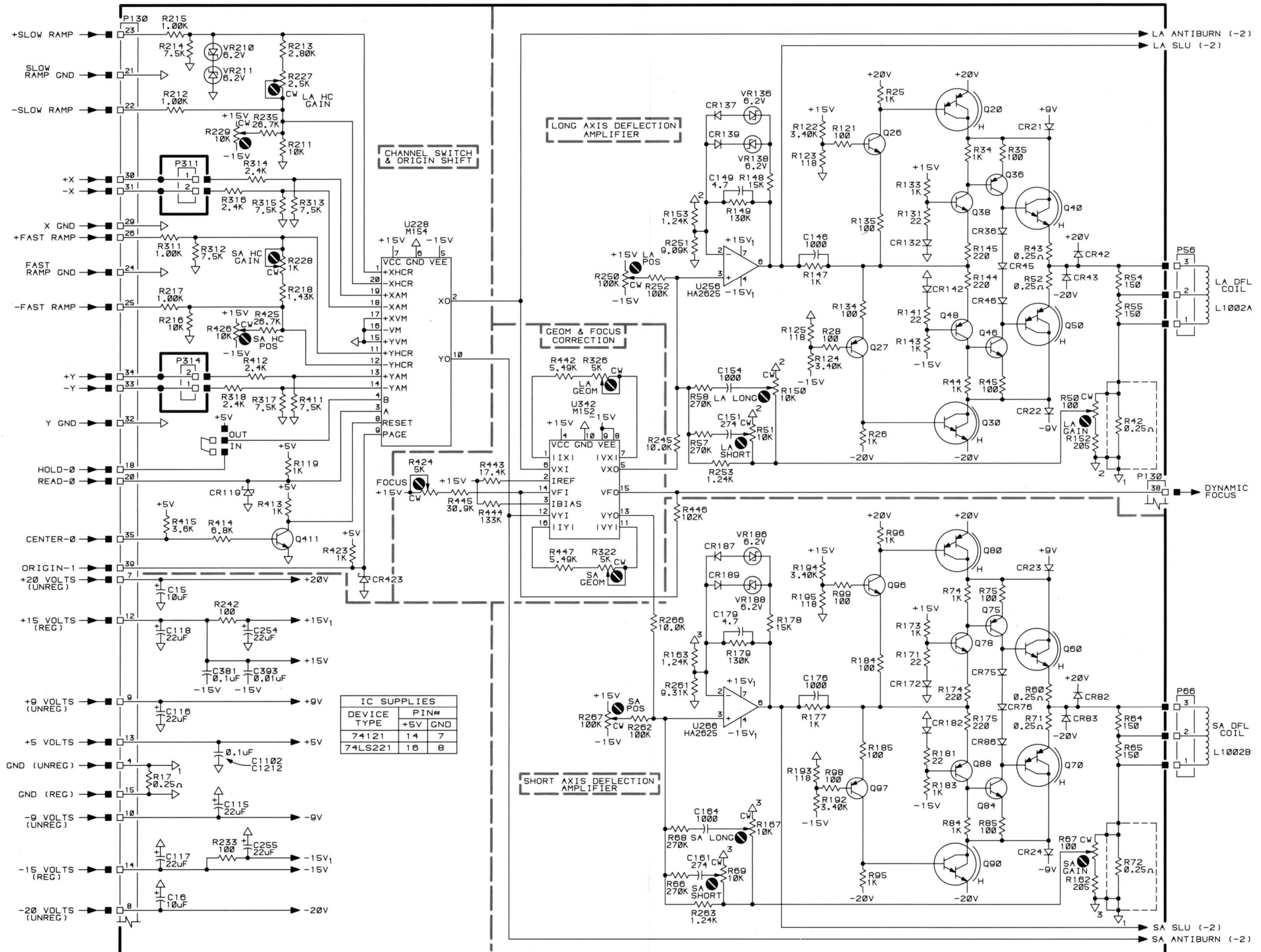

IC SUPPLIES			
DEVICE TYPE	+5V	GND	PIN#
74121	14	7	
74LS221	16	8	

4114

3818-38

672-0901-01 DEFLECTION AMPL. BD. A15A1-1
670-7007-01 (1 OF 2)

DEFLECTION AMPLIFIER A15A1-1
672-0901-01

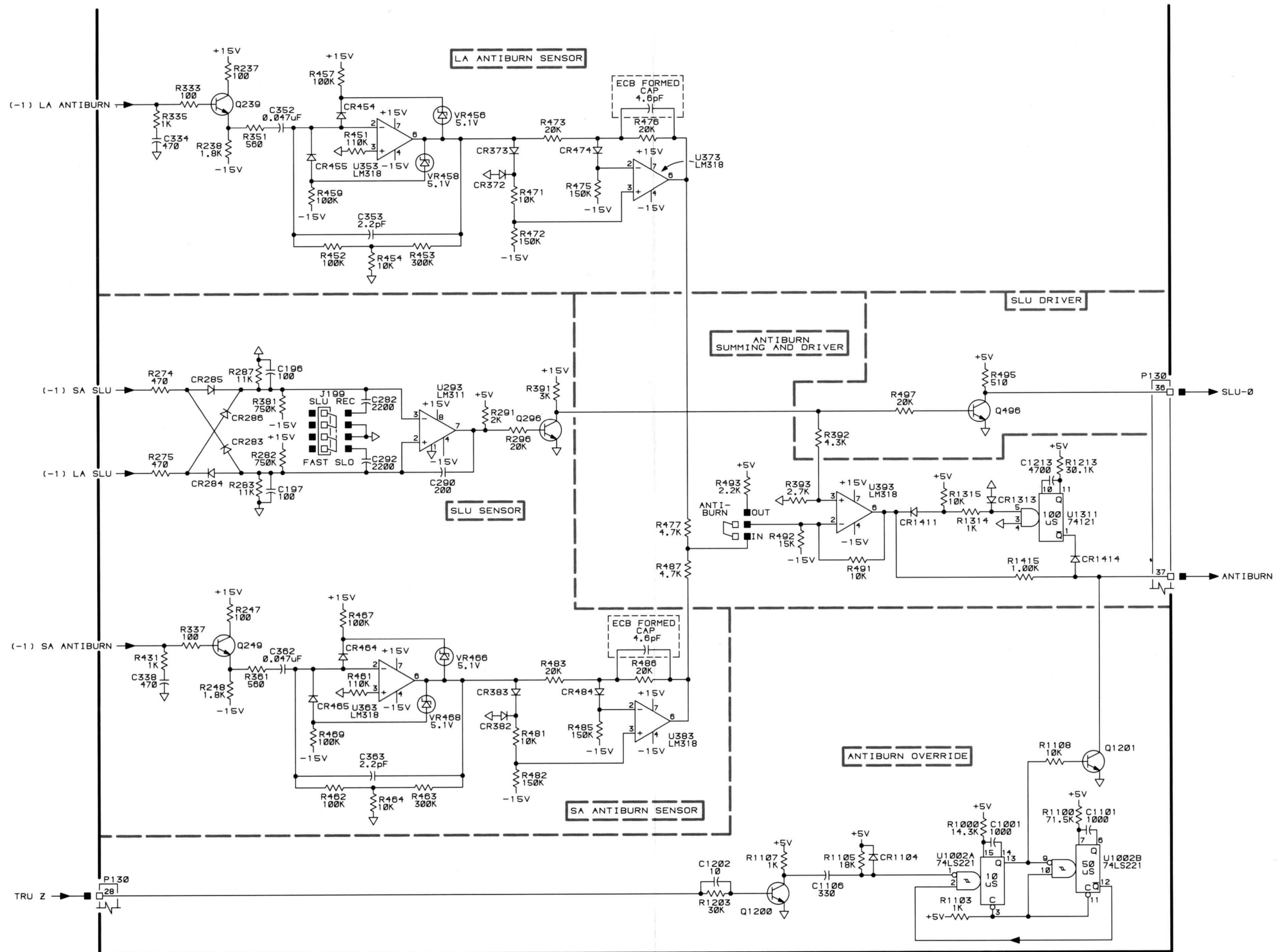

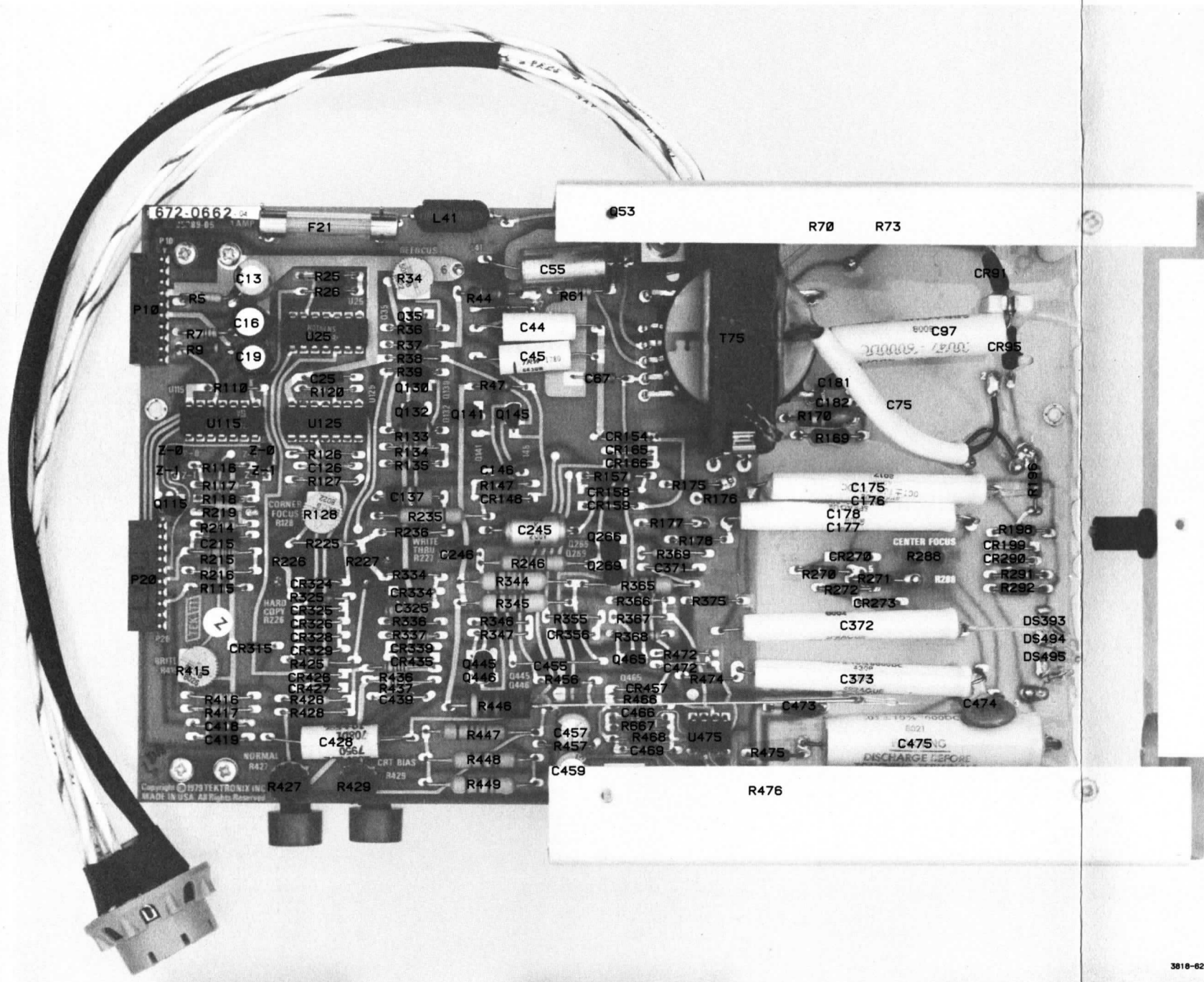

High Voltage and Z-Axis (672-0662-04) Component Locations.

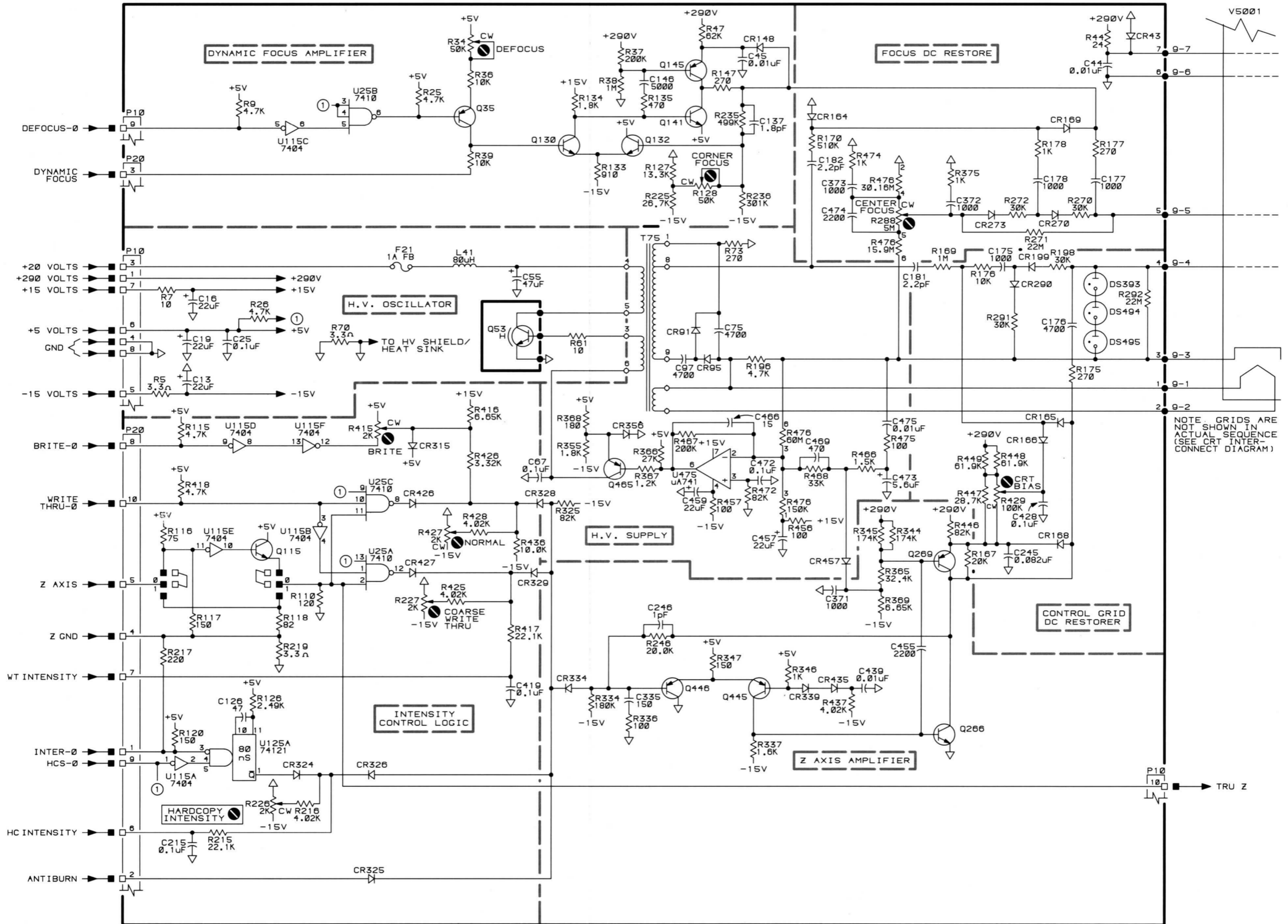

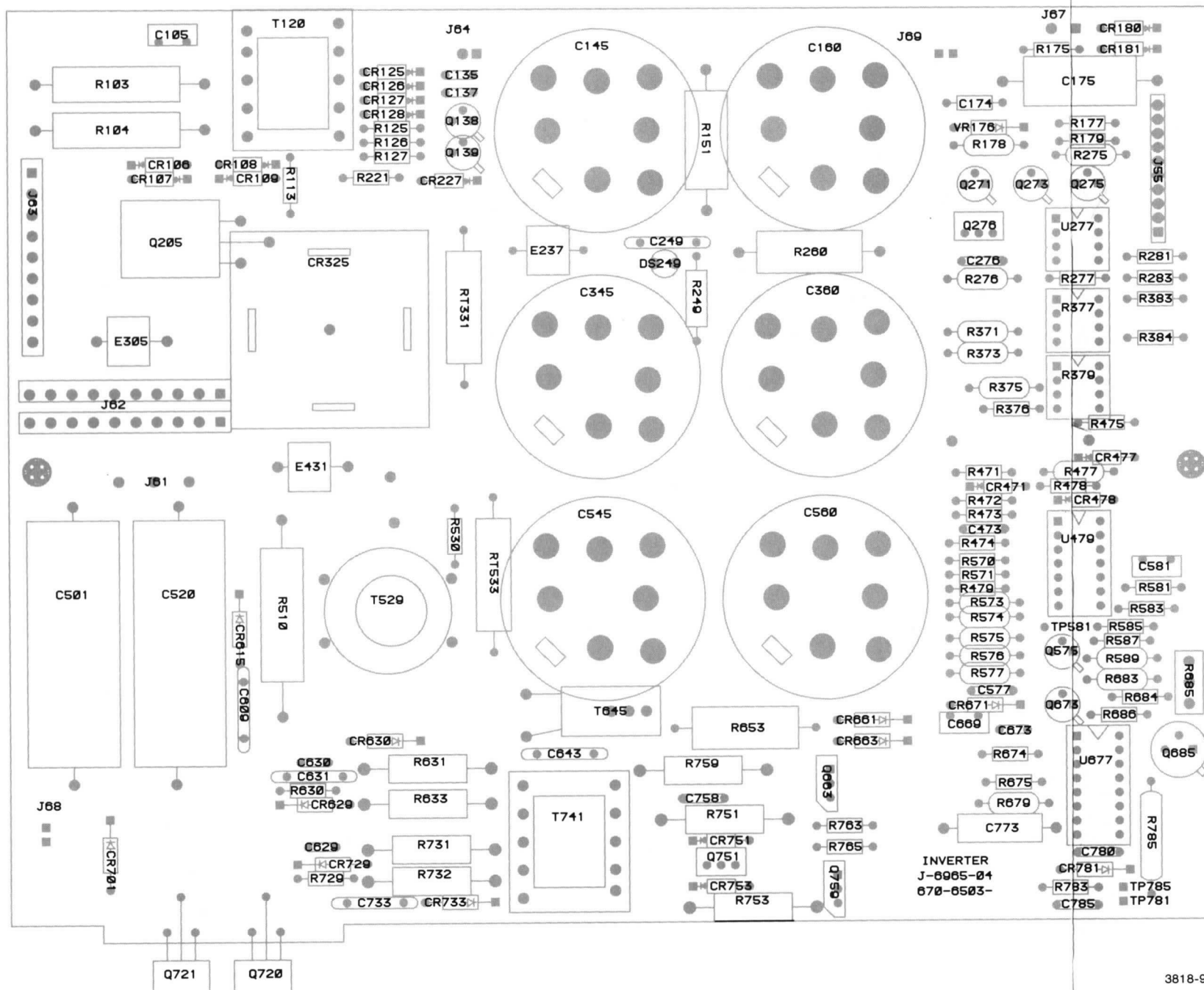

Inverter (670-6503-01,02,03) Component Locations.

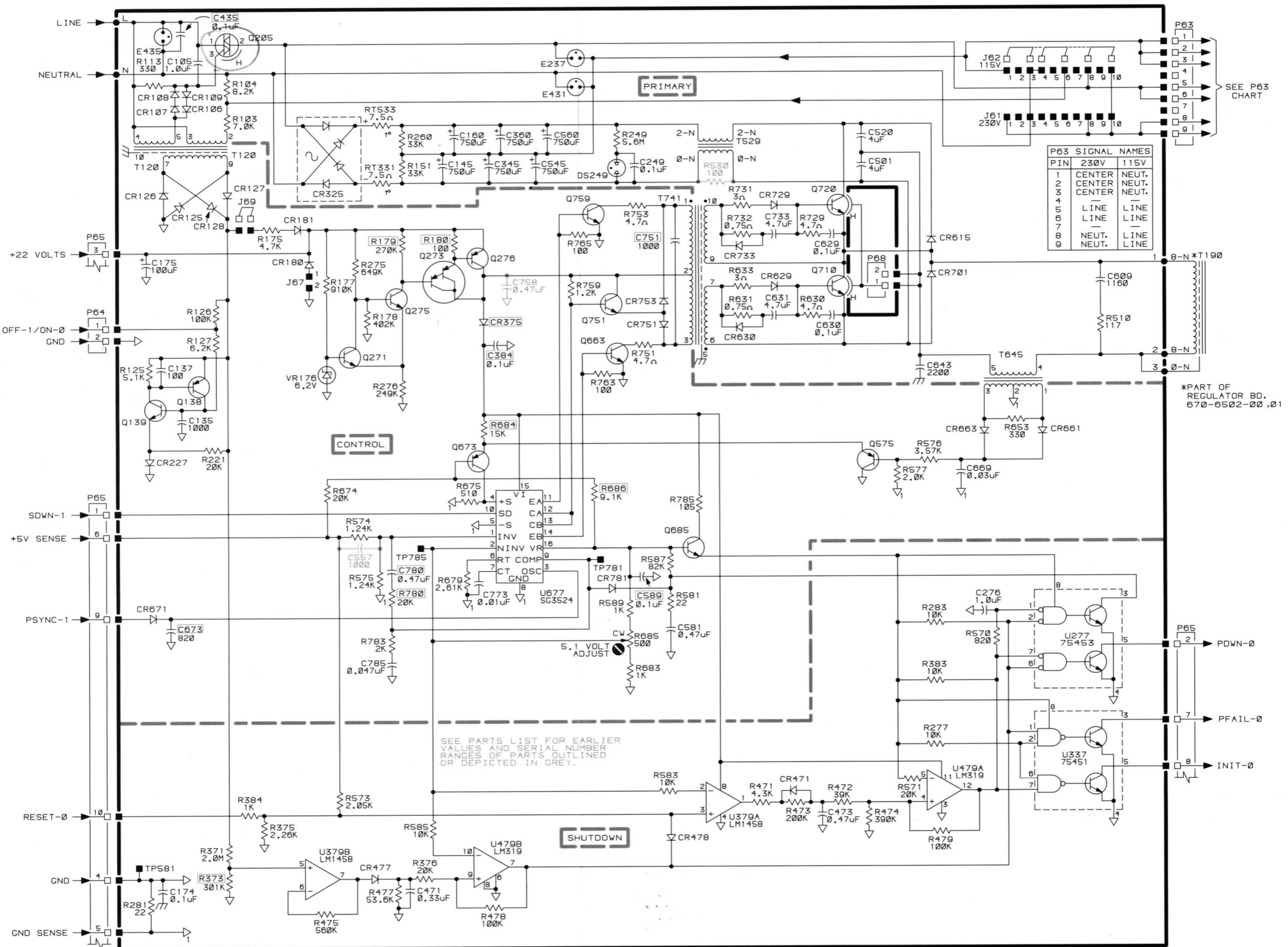

620-0294-00,01
(FOR USE WITH 4114)

REV, JUN 1982
3818-42

670-6503-01,02,03 INVERTER BD. A17A1-1
(1 OF 1)

INVERTER 670-6503-01,02,03 A17A1-1

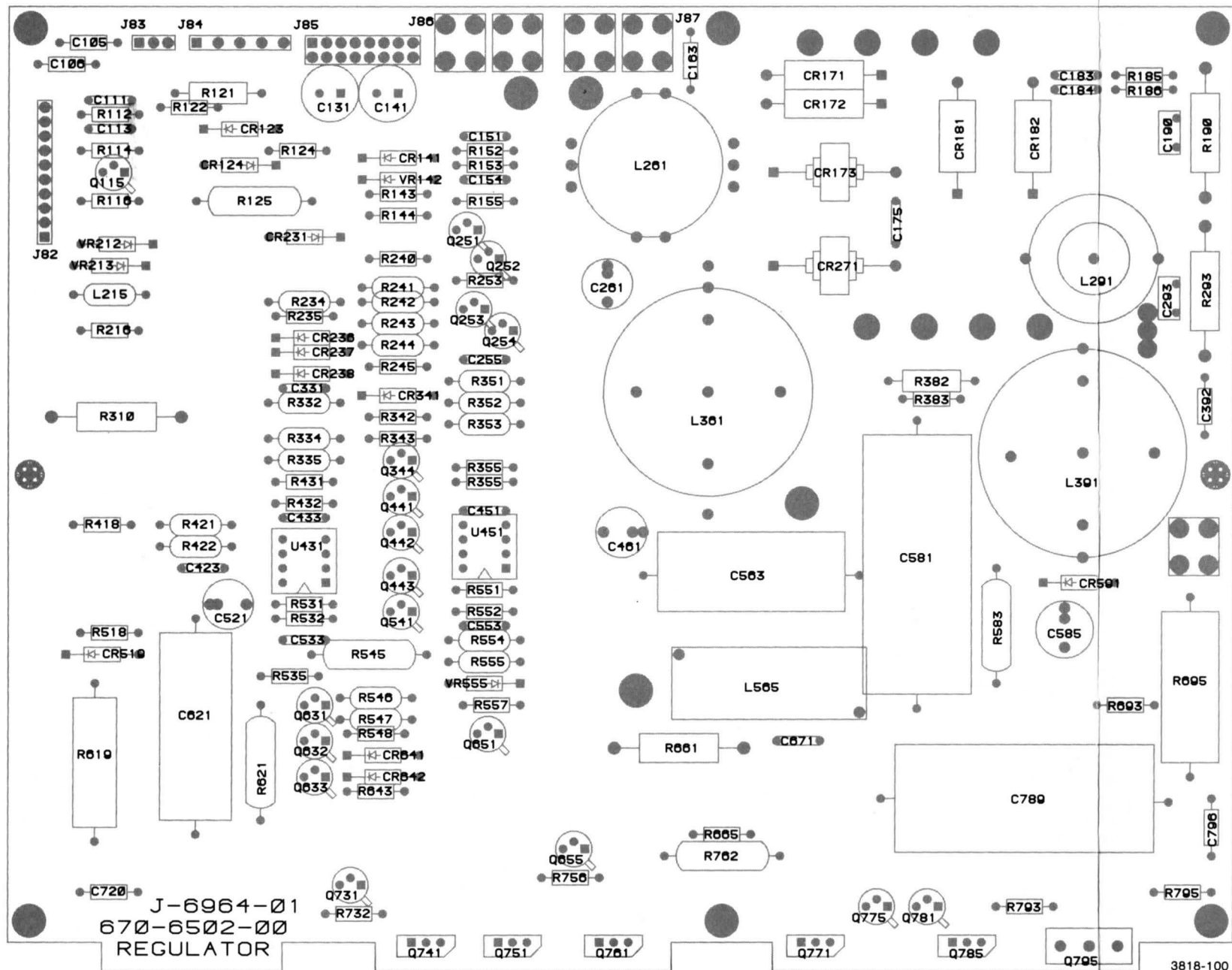

Regulator (670-6502-00,01) Component Locations.

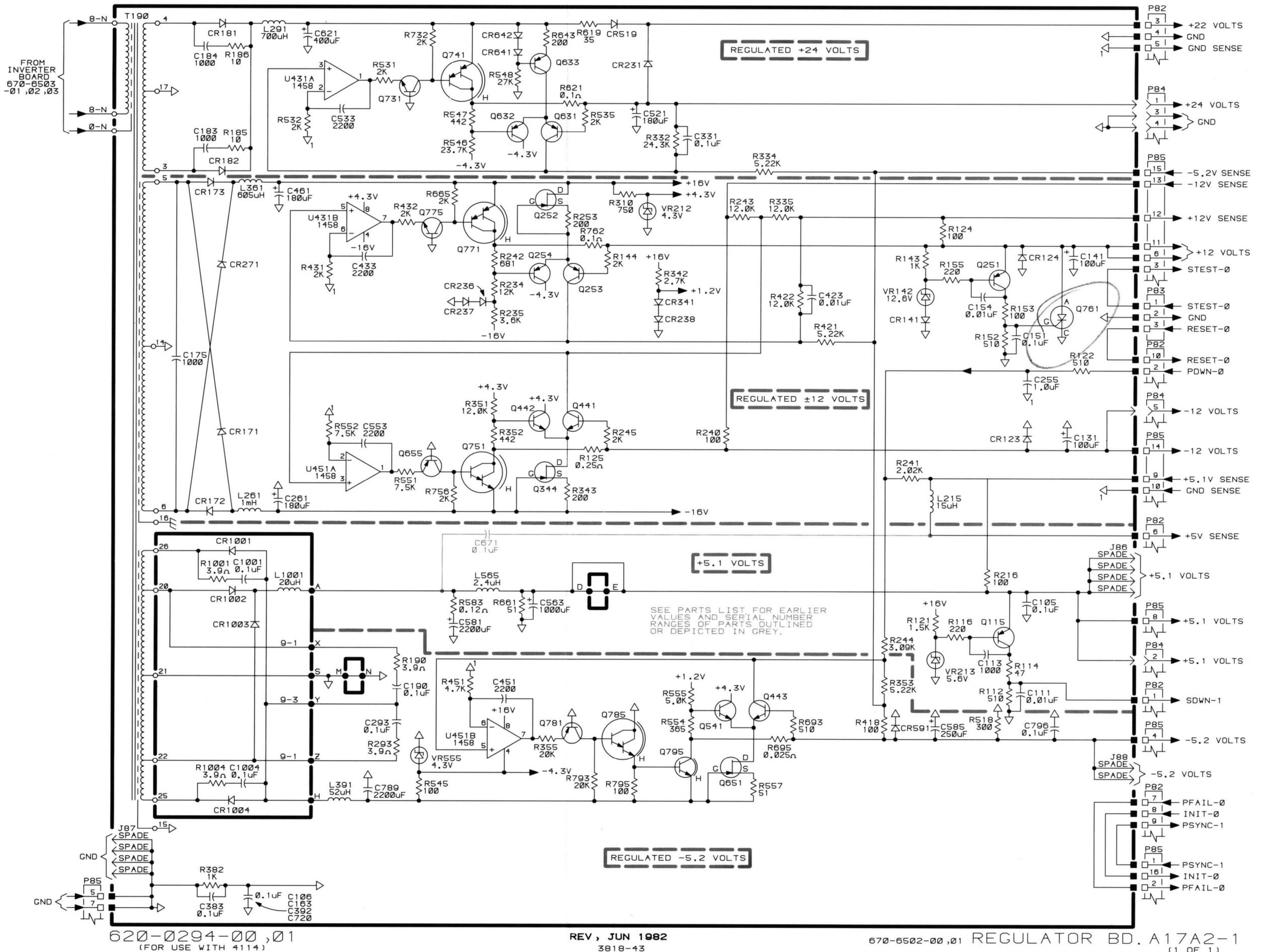

620-0294-00,01
(FOR USE WITH 4114)

REV, JUN 1982
3818-43

670-6502-00,01 REGULATOR BD. A17A2-1
(1 OF 1)

REGULATOR
670-6502-00,01
A17A2-1

Section 9

REPLACEABLE MECHANICAL PARTS

PARTS ORDERING INFORMATION

Replacement parts are available from or through your local Tektronix, Inc. Field Office or representative.

Changes to Tektronix instruments are sometimes made to accommodate improved components as they become available, and to give you the benefit of the latest circuit improvements developed in our engineering department. It is therefore important, when ordering parts, to include the following information in your order: Part number, instrument type or number, serial number, and modification number if applicable.

If a part you have ordered has been replaced with a new or improved part, your local Tektronix, Inc. Field Office or representative will contact you concerning any change in part number.

Change information, if any, is located at the rear of this manual.

SPECIAL NOTES AND SYMBOLS

X000 Part first added at this serial number
00X Part removed after this serial number

FIGURE AND INDEX NUMBERS

Items in this section are referenced by figure and index numbers to the illustrations.

INDENTATION SYSTEM

This mechanical parts list is indented to indicate item relationships. Following is an example of the indentation system used in the description column.

```

1 2 3 4 5           Name & Description
Assembly and/or Component
Attaching parts for Assembly and/or Component
    - - - * - - -
Detail Part of Assembly and/or Component
Attaching parts for Detail Part
    - - - * - - -
Parts of Detail Part
Attaching parts for Parts of Detail Part
    - - - * - - -
  
```

Attaching Parts always appear in the same indentation as the item it mounts, while the detail parts are indented to the right. Indented items are part of, and included with, the next higher indentation. The separation symbol - - - * - - - indicates the end of attaching parts.

Attaching parts must be purchased separately, unless otherwise specified.

ITEM NAME

In the Parts List, an Item Name is separated from the description by a colon (:). Because of space limitations, an Item Name may sometimes appear as incomplete. For further Item Name identification, the U.S. Federal Cataloging Handbook H6-1 can be utilized where possible.

ABBREVIATIONS

"	INCH	ELCTRN	ELECTRON	IN	INCH	SE	SINGLE END
#	NUMBER SIZE	ELEC	ELECTRICAL	INCAND	INCANDESCENT	SECT	SECTION
ACTR	ACTUATOR	ELCLTL	ELECTROLYTIC	INSUL	INSULATOR	SEMICOND	SEMICONDUCTOR
ADPTR	ADAPTER	ELEM	ELEMENT	INTL	INTERNAL	SHLD	SHIELD
ALIGN	ALIGNMENT	EPL	ELECTRICAL PARTS LIST	LPHLDR	LAMPHOLDER	SHLDR	SHOULDERED
AL	ALUMINUM	EQPT	EQUIPMENT	MACH	MACHINE	SKT	SOCKET
ASSEM	ASSEMBLED	EXT	EXTERNAL	MECH	MECHANICAL	SL	SLIDE
ASSY	ASSEMBLY	FIL	FILLISTER HEAD	MTG	MOUNTING	SLFLKG	SELF-LOCKING
ATTEN	ATTENUATOR	FLX	FLEXIBLE	NIP	NIPPLE	SLVG	SLEEVING
AWG	AMERICAN WIRE GAGE	FLH	FLAT HEAD	NON WIRE	NOT WIRE WOUND	SPR	SPRING
BD	BOARD	FLTR	FILTER	OBDD	ORDER BY DESCRIPTION	SQ	SQUARE
BRKT	BRACKET	FR	FRAME or FRONT	OD	OUTSIDE DIAMETER	SST	STAINLESS STEEL
BRS	BRASS	FSTNR	FASTENER	OVH	OVAL HEAD	STL	STEEL
BRZ	BRONZE	FT	FOOT	PH BRZ	PHOSPHOR BRONZE	SW	SWITCH
BSHG	BUSHING	FXD	FIXED	PL	PLAIN or PLATE	T	TUBE
CAB	CABINET	GSKT	GASKET	PLSTC	PLASTIC	TERM	TERMINAL
CAP	CAPACITOR	HDL	HANDLE	PN	PART NUMBER	THD	THREAD
CER	CERAMIC	HEX	HEXAGON	PNH	PAN HEAD	THK	THICK
CHAS	CHASSIS	HEX HD	HEXAGONAL HEAD	PWR	POWER	TNSN	TENSION
CKT	CIRCUIT	HEX SOC	HEXAGONAL SOCKET	RCPT	RECEPTACLE	TPG	TAPPING
COMP	COMPOSITION	HLCPS	HELICAL COMPRESSION	RES	RESISTOR	TRH	TRUSS HEAD
CONN	CONNECTOR	HLEXT	HELICAL EXTENSION	RGD	RIGID	V	VOLTAGE
COV	COVER	HV	HIGH VOLTAGE	RLF	RELIEF	VAR	VARIABLE
CPLG	COUPLING	IC	INTEGRATED CIRCUIT	RTNR	RETAINER	W/	WITH
CRT	CATHODE RAY TUBE	ID	INSIDE DIAMETER	SCH	SOCKET HEAD	WSHR	WASHER
DEG	DEGREE	IDNT	IDENTIFICATION	SCOPE	OSCILLOSCOPE	XFMR	TRANSFORMER
DWR	DRAWER	IMPLR	IMPELLER	SCR	SCREW	XSTR	TRANSISTOR

REPLACEABLE MECHANICAL PARTS

CROSS INDEX—MFR. CODE NUMBER TO MANUFACTURER

Mfr. Code	Manufacturer	Address	City, State, Zip
S3109	FELLER ASA ADOLF AG., C/O PANEL COMPONENTS CORP.	355 TESCONI CIRCLE	SANTA ROSA, CA 95401
S3629	PANEL COMPONENTS CORP.	2015 SECOND ST.	BERKELEY, CA 94170
000AD	EOFF ELECTRIC COMPANY	P.O. BOX 2828	PORTLAND, OR 97208
000BR	IRVIN-HODSON	2838 SE 9TH	PORTLAND, OR 97202
000CA	MOLEX	2222 WELLINGTON COURT	LYLE, ILLINOIS 60532
000CP	AIMSCO	4024 22ND AVE. WEST	SEATTLE, WA 98199
000CY	NORTHWEST FASTENER SALES, INC.	7923 SW CIRBUS DRIVE	BEAVERTON, OR 97005
000EP	AROW FASTENERS INC.	2112 AMERICAN AVENUE	HAYWARD, CA 94545
000IH	P/M INDUSTRIES INC.	14320 N.W. SCIENCE PARK DR.	PORTLAND, ORE 97229
000II	POWELL ELECTRONICS	722 E EVELYN AVE	SUNNYVALE, CA 94086
000IJ	TDK ELECTRONICS CO. LTD C/O KING ASSOCIATES	3380 VISO COURT	SANTA CLARA, CA 95050
000IK	CONNECT-AIR	50 37TH STR N.E.	AUBURN, WA 98002
000IL	FRANK JACKSON CO.	4475 S.W. SCHOLLS FERRY RD.	PORTLAND, ORE 97225
00613	USM CORPORATION, MOLLY FASTENER DIVISION	504 MT. LAUREL AVENUE	TEMPLE, PA 19560
00779	AMP, INC.	P O BOX 3608	HARRISBURG, PA 17105
01295	TEXAS INSTRUMENTS, INC., SEMICONDUCTOR GROUP	P O BOX 5012, 13500 N CENTRAL EXPRESSWAY	DALLAS, TX 75222
02107	SPARTA MANUFACTURING COMPANY	ROUTE NO. 2, BOX 128	DOVER, OH 44622
02114	FERROXCUBE CORPORATION	PO BOX 359, MARION ROAD	SAUGERTIES, NY 12477
02777	HOPKINS ENGINEERING COMPANY	12900 FOOTHILL BLVD.	SAN FERNANDO, CA 91342
04919	COMPONENT MANUFACTURING SERVICE, INC.	1 COMPONENT PARK WEST	BRIDGEWATER, MA 02379
06004	BASSICK, DIVISION STEWART-WARNER CORP.	960 ATLANTIC STREET	BRIDGEPORT, CT 06602
08261	SPECTRA-STRIP CORP.	7100 LAMPSON AVE.	GARDEN GROVE, CA 92642
08530	RELIANCE MICA CORP.	342-39TH ST.	BROOKLYN, NY 11232
09922	BURNDY CORPORATION	RICHARDS AVENUE	NORWALK, CT 06852
10112	VERNITRON CONTROL COMPONENTS A DIVISION OF VERNITRON CORP.	1601 PRECISION PARK LN P O BOX 867, 1757 STANFORD ST.	SAN DIEGO, CA 92073 SANTA MONICA, CA 90406
11897	PLASTIGLIDE MFG. CORPORATION		
12324	STAKE FASTENER CO DIV OF DUPREE INC.	9835 DUPREE ST P.O. BOX 3156	SOUTH EL MONTE, CA 91733
12327	FREEWAY CORPORATION	9301 ALLEN DRIVE	CLEVELAND, OH 44125
13130	CLEVELAND TWIST DRILL COMPANY, A SUB OF ACME CLEVELAND CORPORATION	PO BOX 6656	CLEVELAND, OH 44101
18565	CHOMERICS INC.	77 DRAGON COURT	WOBNURN, MA 01801
22526	BERG ELECTRONICS, INC.	YOUK EXPRESSWAY	NEW CUMBERLAND, PA 17070
22670	G.M. NAMEPLATE, INC.	2040 15TH AVENUE WEST	SEATTLE, WA 98119
24618	TRANSCON MFG. CO.	2655 PERTH ST.	DALLAS, TX 75220
24931	SPECIALITY CONNECTOR CO., INC.	2620 ENDRESS PLACE	GREENWOOD, IN 46142
27264	MOLEX PRODUCTS CO.	5224 KATRINE AVE.	DOWNERS GROVE, IL 60515
28520	HEYMAN MFG. CO.	147 N. MICHIGAN AVE.	KENILWORTH, NJ 07033
29598	BIC PEN CORPORATION	WILEY STREET	MILFORD, CT 06460
34785	DEK INC.	1555 HAWTHORNE LN.	W CHICAGO, IL 60185
51181	KEYTRONICS INC.	707 NORTH ST.	ENDICOTT, NY 13760
52833	KEYTRONIC CORP., OCR DIV.	SPOKANE INDUSTRIAL PK., P. O. BOX 14687	SPOKANE, WA 99214
54473	MATSUSHITA ELECTRIC, CORP. OF AMERICA	1 PANASONIC WAY	SECAUCUS, NJ 07094
59730	THOMAS AND BETTS COMPANY	36 BUTLER ST.	ELIZABETH, NJ 07207
70485	ATLANTIC INDIA RUBBER WORKS, INC.	571 W. POLK ST.	CHICAGO, IL 60607
70903	BELDEN CORP.	2000 S BATAVIA AVENUE	GENEVA, IL 60134
71468	ITT CANNON ELECTRIC	666 E. DYER RD.	SANTA ANA, CA 92702
72653	G. C. ELECTRONICS CO., A DIVISION OF HYDROMETALS, INC.	400 S. WYMAN ST.	ROCKFORD, IL 61101
73743	FISCHER SPECIAL MFG. CO.	446 MORGAN ST.	CINCINNATI, OH 45206
75497	LAMSON AND SESSIONS CO.	5000 TIEDEMAN ROAD	CLEVELAND, OH 44144
77339	NATIONAL LOCK WASHER COMPANY	P O BOX 5115, INDUSTRIAL PARKWAY	NORTH BRANCH, NJ 08856
77342	AMF INC., POTTER AND BRUMFIELD DIV.	200 RICHLAND CREEK DRIVE	PRINCETON, IN 47670
78189	ILLINOIS TOOL WORKS, INC. SHAKEPROOF DIVISION	ST. CHARLES ROAD	ELGIN, IL 60120
79807	WROUGHT WASHER MFG. CO.	2100 S. O BAY ST.	MILWAUKEE, WI 53207
80009	TEKTRONIX, INC.	P O BOX 500	BEAVERTON, OR 97077
80126	PACIFIC ELECTRICCORD CO.	747 W. REDONDO BEACH, P O BOX 10	GARDENA, CA 90247
81646	PARKER HANNIFER CORP., CLAMP & FASTENER DIV.	1000 PENNSYLVANIA AVE.	BROOKLYN, NY 11207

CROSS INDEX—MFR. CODE NUMBER TO MANUFACTURER

Mfr. Code	Manufacturer	Address	City, State, Zip
82877	ROTRON, INC.	7-9 HASBROUCK LANE	WOODSTOCK, NY 12498
83309	ELECTRICAL SPECIALITY CO., SUBSIDIARY OF BELDEN CORP.	213 E. HARRIS AVE. SOUTH	SAN FRANCISCO, CA 94080
83385	CENTRAL SCREW CO.	2530 CRESCENT DR.	BROADVIEW, IL 60153
85471	BOYD, A. B., CO.	2527 GRANT AVENUE	SAN LEANDRO, CA 94579
86044	CALIFORNIA GASKET COMPANY	1601 W. 134 STREET	GARDENA, CA 90249
86445	PENN FIBRE AND SPECIALTY CO., INC.	2032 E. WESTMORELAND ST.	PHILADELPHIA, PA 19134
86928	SEASTROM MFG. COMPANY, INC.	701 SONORA AVENUE	GLENDALE, CA 91201
91260	CONNOR SPRING AND MFG. CO.	1729 JUNCTION AVE.	SAN JOSE, CA 95112
93907	TEXTRON INC. CAMCAR DIV	600 18TH AVE	ROCKFORD, IL 61101
95987	WECKESSER CO., INC.	4444 WEST IRVING PARK RD.	CHICAGO, IL 60641
97464	INDUSTRIAL RETAINING RING CO.	57 CORDIER ST.	IRVINGTON, NJ 07111
98159	RUBBER TECK, INC.	19115 HAMILTON AVE., P O BOX 389	GARDENA, CA 90247
99742	PERMACEL DIV. OF JOHNSON AND JOHNSON	U. S. HIGHWAY 1	NEW BRUNSWICK, NJ 08901

REPLACEABLE MECHANICAL PARTS

Fig. & Index No.	Tektronix Part No.	Serial/Model No. Eff	Dscont	Qty	1	2	3	4	5	Name & Description	Mfr Code	Mfr Part Number
1-1	390-0780-03			1						CABINET TOP:W/BRACKETS (ATTACHING PARTS)	80009	390-0780-03
-2	210-0457-00			10						NUT, PL, ASSEM WA:6-32 X 0.312, STL CD PL - - - * - - -	83385	OBD
-3	426-1707-00			2						FRAME SECT, CAB:UPPER, LEFT & RIGHT, AL (ATTACHING PARTS)	80009	426-1707-00
-4	210-0457-00			6						NUT, PL, ASSEM WA:6-32 X 0.312, STL CD PL - - - * - - -	83385	OBD
-5	333-2634-01			1						PANEL, REAR: (ATTACHING PARTS)	80009	333-2634-01
-6	212-0023-00			7						SCREW, MACHINE:0-32 X 0.375, PNH, STL CD PL - - - * - - -	83385	OBD
-7	200-2471-00			1						COVER, CRT:ALUMINUM (ATTACHING PARTS)	80009	200-2471-00
-8	210-0457-00			3						NUT, PL, ASSEM WA:6-32 X 0.312, STL CD PL - - - * - - -	83385	OBD
-9	366-1522-00			1						KNOB:LINE VOLTAGE INDICATOR (ATTACHING PARTS)	80009	366-1522-00
-10	211-0507-00			1						SCREW, MACHINE:6-32 X 0.312 INCH, PNH STL - - - * - - -	83385	OBD
-11	390-0781-01			1						CABINET BOTTOM: (ATTACHING PARTS)	80009	390-0781-01
-12	212-0008-00			13						SCREW, MACHINE:8-32 X 0.500 INCH, PNH STL	83385	OBD
-13	212-0023-00			3						SCREW, MACHINE:0-32 X 0.375, PNH, STL CD PL - - - * - - -	83385	OBD
-14	426-1708-00			2						FRAME SECT, CAB:LOWER, LEFT & RIGHT, AL (ATTACHING PARTS)	80009	426-1708-00
-15	210-0457-00			6						NUT, PL, ASSEM WA:6-32 X 0.312, STL CD PL - - - * - - -	83385	OBD
-16	343-0899-02			1						RETAINER, MON: (ATTACHING PARTS)	80009	343-0899-02
-17	212-0507-00			4						SCREW, MACHINE:10-32 X 0.375 INCH, PNH STL - - - * - - -	83385	OBD
-18	334-3854-01			1						MARKER, IDENT:MKD 4114	80009	334-3854-01
-19	333-2657-01			1						PANEL, FRONT: (ATTACHING PARTS)	80009	333-2657-01
-20	210-0457-00			2						NUT, PL, ASSEM WA:6-32 X 0.312, STL CD PL - - - * - - -	83385	OBD
-21	366-1864-01			1						KNOB:0.46 ID X 0.50D X 0.562 H (ATTACHING PARTS)	80009	366-1864-01
-22	213-0153-00			1						. SETSCREW:5-40 X 0.125, STL BK OXD, HEX SKT - - - * - - -	000CY	OBD
-23	-----			1						RESISTOR, VAR:(SEE R5001 REPL CHASSIS PARTS) (ATTACHING PARTS)		
-24	210-0046-00			1						WASHER, LOCK:0.261 ID, INTL, 0.018 THK, BRS	78189	1214-05-00-0541C
-25	210-0940-00			1						WASHER, FLAT:0.25 ID X 0.375 INCH OD, STL	79807	OBD
-26	210-0583-00			1						NUT, PLAIN, HEX:0.25-32 X 0.312 INCH, BRS - - - * - - -	73743	2X20317-402
-27	175-3225-00			1						CA ASSY, SP, ELEC:3, 26 AWG, 12.0L RIBBON	80009	175-3225-00
-28	175-0826-00			AR						. WIRE, ELECTRICAL:3 WIRE RIBBON	80009	175-0826-00
-29	131-0707-00			3						. CONNECTOR, TERM:22-26 AWG, BRS & CU BE GOLD	22526	47439
-30	352-0162-00			1						. HLD, TERM CONN:4 WIRE BLACK . (A11J35)	80009	352-0162-00
-31	348-0128-00			4						BUMPER, PLASTIC:CABINET MTG, 2.022 INCH LONG (ATTACHING PARTS)	80009	348-0128-00
-32	211-0514-00			8						SCREW, MACHINE:6-32 X 0.750 INCH, PNH STL - - - * - - -	83385	OBD
-33	195-1722-00			1						LEAD, ELECTRICAL:18 AWG, 3.0 L, 0-N	80009	195-1722-00
-34	210-0322-00			2						. TERMINAL LUG:#10, SOLDERLESS, CU TIN PL	00779	34149
-35	210-0322-00			1						. TERMINAL LUG:#10, SOLDERLESS, CU TIN PL	00779	34149

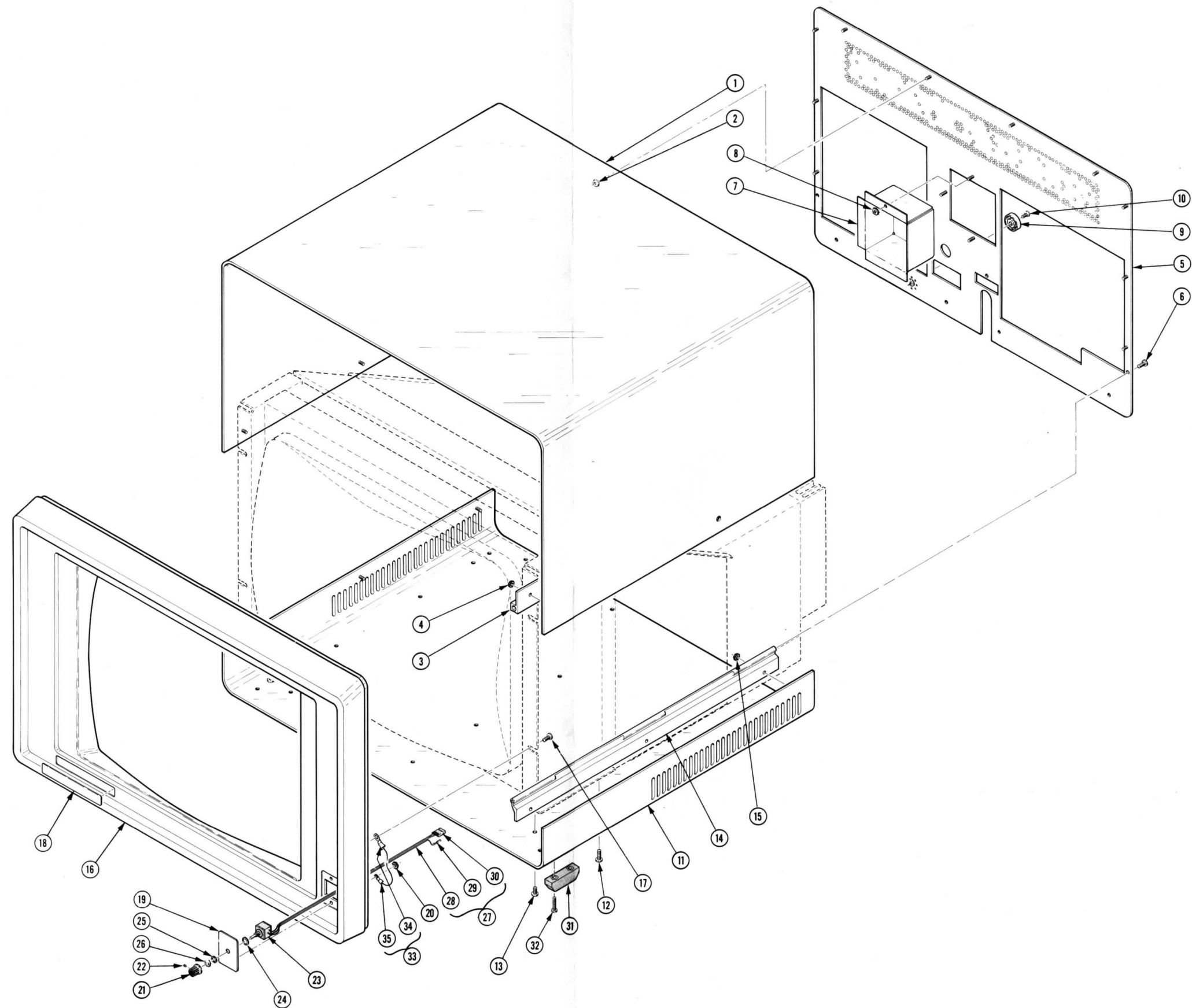
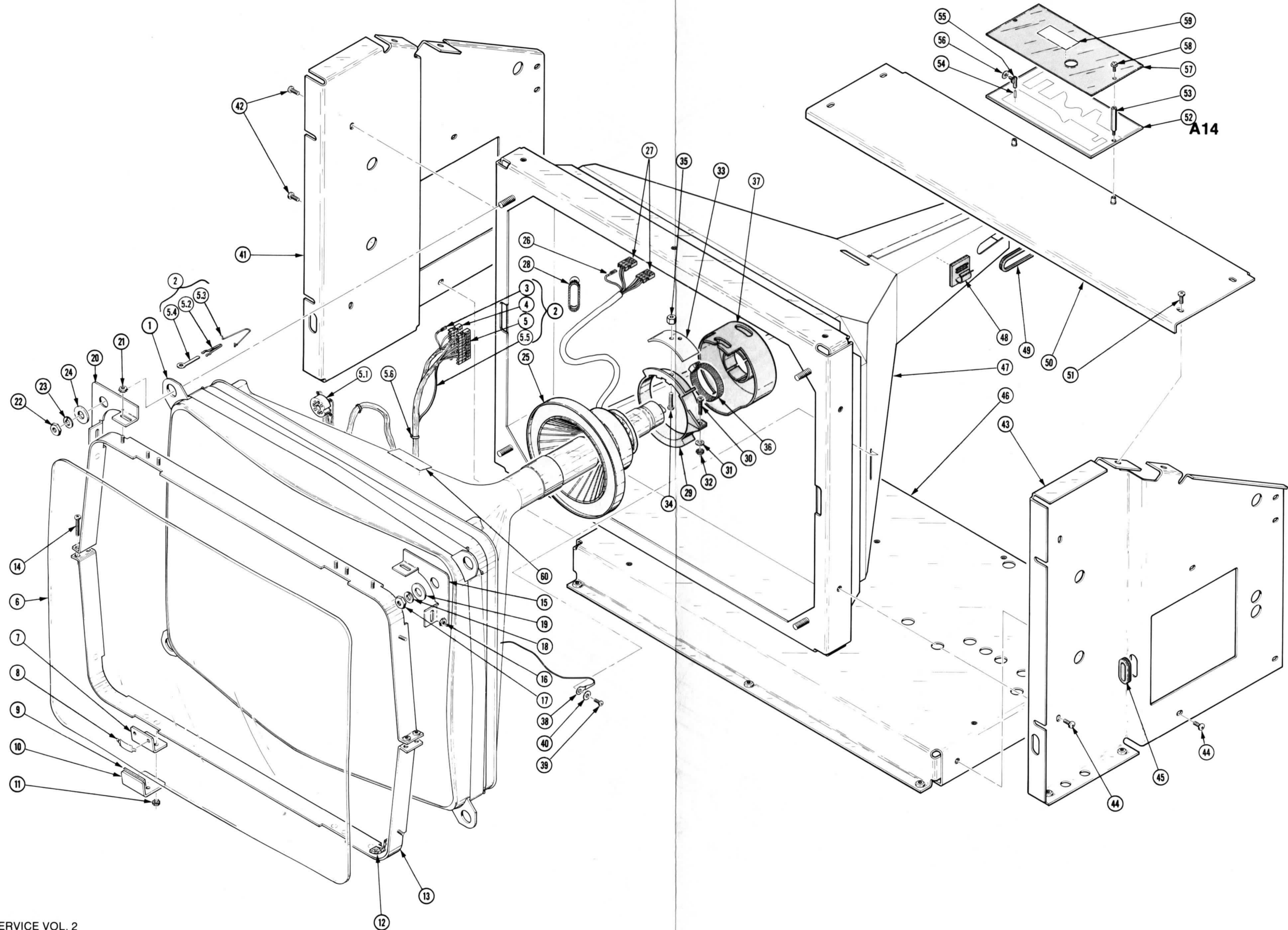

FIG. 2 DISPLAY CHASSIS, CRT



REPLACEABLE MECHANICAL PARTS

Fig. & Index No.	Tektronix Part No.	Serial/Model No. Eff Dscont	Qty	1	2	3	4	5	Name & Description	Mfr Code	Mfr Part Number
2-1	-----		1						ELECTRON TUBE:CRT W/CABLE(SEE V5001 REPL)		
-2	179-2424-02		1						. WIRING HARNESS:CRT	80009	179-2424-02
-3	131-0792-00		1						. . CONNECTOR,TERM:18-20 AWG,CU BE GOLD PL	22526	46221
	131-0622-00		1						. . CONTACT,ELEC:0.577"L,28-32 AWG WIRE	22526	46241
	131-0621-00		8						. . CONNECTOR,TERM:22-26 AWG,BRS& CU BE GOLD	22526	46231
-4	352-0206-03		1						. . HLDR,TERM CONN:10 WIRE ORANGE	80009	352-0206-03
-5	352-0206-04		1						. . HLDR,TERM CONN:10 WIRE YELLOW	80009	352-0206-04
-5.1	136-0660-00		1						. . SKT,PL-IN ELEK:FLOOD GUN	80009	136-0660-00
-5.2	344-0035-00		3						. . CLIP,ELECTRICAL:SNAP-ON	80009	344-0035-00
-5.3	131-1594-00		2						. . CONTACT,ELEC:ANODE,0.042 DIA SPR STL,U-SHP	91260	OBD
-5.4	210-0224-00		2						. . TERMINAL,LUG:0.20 ID X 0.344 OD,SE,BRS	86928	A373-148-1
-5.5	175-1020-09		AR						. . CABLE,RF:50 OHM COAX,W/WHT VINYL JKT	80009	175-1020-09
-5.6	343-0549-00		11						. . STRAP,TIEDOWN:0.091 W X 3.62 INCH LONG	59730	TY100
-6	337-1981-01		1						SHLD,IMPLOSION:GREEN	80009	337-1981-01
-7	352-0490-00		4						HOLDER,CONTACT:	80009	352-0490-00
-8	131-1520-00		4						CONTACT,ELEC:GROUNDING	80009	131-1520-00
-9	253-0137-00		AR						RL TAPE:1.25W X 4.5 INCH L,ADH,SIL RBR	99742	2650
-10	343-0666-00		4						CLAMP,FILTER:UPPER LEFT,LOWER RIGHT (ATTACHING PARTS)	80009	343-0666-00
-11	210-0457-00		8						NUT,PL,ASSEM WA:6-32 X 0.312,STL CD PL - - - * - - -	83385	OBD
-12	255-0569-00		AR						TAPE,PRESS SENS:108 FT X 0.5 X 0.125	99742	PU25F
-13	346-0157-00		2						STRAP,RETAINING:LOWER & UPPER,FILTER (ATTACHING PARTS)	80009	346-0157-00
-14	211-0516-00		4						SCREW,MACHINE:6-32 X 0.875 INCH,PNH STL - - - * - - -	83385	OBD
-15	407-2019-00		2						BRKT,RTNG STRAP:LWR LEFT OR UPPER RIGHT,AL (ATTACHING PARTS)	80009	407-2019-00
-16	210-0457-00		4						NUT,PL,ASSEM WA:6-32 X 0.312,STL CD PL	83385	OBD
-17	210-0411-00		2						NUT,PLAIN,HEX.:0.25-20 X 0.438 INCH STL	73743	OBD
-18	210-0016-00		2						WASHER,LOCK:SPLIT,0.259 ID X 0.489 OD,STL	77339	6507
-19	210-1044-00		2						WASHER,FLAT:0.375 ID X 0.75 INCH OD,STL - - - * - - -	86928	OBD
-20	407-2018-00		2						BRKT,RTNG STRAP:UPPER LEFT OR LWR RIGHT,AL (ATTACHING PARTS)	80009	407-2018-00
-21	210-0457-00		4						NUT,PL,ASSEM WA:6-32 X 0.312,STL CD PL	83385	OBD
-22	210-0411-00		2						NUT,PLAIN,HEX.:0.25-20 X 0.438 INCH STL	73743	OBD
-23	210-0016-00		2						WASHER,LOCK:SPLIT,0.259 ID X 0.489 OD,STL	77339	6507
-24	210-1044-00		2						WASHER,FLAT:0.375 ID X 0.75 INCH OD,STL - - - * - - -	86928	OBD
-25	119-0971-00		1						COIL,TUBE DEFL:	80009	119-0971-00
-26	131-0621-00		6						. CONNECTOR,TERM:22-26 AWG,BRS& CU BE GOLD	22526	46231
-27	352-0199-00		2						. CONN BODY,PL,EL:3 WIRE BLACK	80009	352-0199-00
-28	255-0334-00		2						PLASTIC CHANNEL:12.75 X 0.175X 0.155,NYL	11897	122-37-2500
-29	343-0664-00		1						CLAMP,CRT:YOKE (ATTACHING PARTS)	80009	343-0664-00
-30	211-0513-00		1						SCREW,MACHINE:6-32 X 0.625 INCH,PNH STL	83385	OBD
-31	210-0803-00		1						WASHER,FLAT:0.15 ID X 0.032 THK,STL CD PL	12327	OBD
-32	210-0457-00		1						NUT,PL,ASSEM WA:6-32 X 0.312,STL CD PL - - - * - - -	83385	OBD
-33	343-0670-00		1						CLAMP,CRT: (ATTACHING PARTS)	80009	343-0670-00
-34	212-0100-00		1						SCREW,MACHINE:8-32 X 0.625 INCH,HEX.HD,STL	83385	OBD
-35	129-0640-00		1						SPACER,POST:0.75 L,W/6-32THD ONE END,AL - - - * - - -	80009	129-0640-00
-36	343-0808-00		1						CLAMP,HOSE:0.75 ID SST,NON MAGNETIC	81646	6320
-37	343-0777-00		1						CLAMP,NECK,CRT:NYLON,BLACK	80009	343-0777-00
-38	210-0224-00		2						TERMINAL,LUG:0.20 ID X 0.344 OD,SE,BRS (ATTACHING PARTS)	86928	A373-148-1
-39	213-0146-00		2						SCR,TPG,THD FOR:6-20 X 0.313 INCH,PNH STL	83385	OBD
-40	210-0803-00		2						WASHER,FLAT:0.15 ID X 0.032 THK,STL CD PL - - - * - - -	12327	OBD
-41	407-2502-00		1						BRACKET,CRT:LEFT,AL (ATTACHING PARTS)	80009	407-2502-00
-42	212-0023-00		6						SCREW,MACHINE:0-32 X 0.375,PNH,STL CD PL - - - * - - -	83385	OBD

REPLACEABLE MECHANICAL PARTS

Fig. & Index No.	Tektronix Part No.	Serial/Model No. Eff Dscont	Qty	1	2	3	4	5	Name & Description	Mfr Code	Mfr Part Number
2-43	407-2501-00		1						BRACKET,CRT:RIGHT,AL (ATTACHING PARTS)	80009	407-2501-00
-44	212-0023-00		5						SCREW,MACHINE:0-32 X 0.375,PNH,STL CD PL -----*	83385	OBD
-45	348-0006-00		2						GROMMET,RUBBER:0.562 ID X 0.875 INCH OD	70485	1720
-46	441-1523-01		1						CHASSIS,TERM:MAIN,W/BRACKETS	80009	441-1523-01
-47	650-0245-00		1						MECHANICAL KIT:	80009	650-0245-00
-48	343-0835-00		1						CLAMP,LOOP:0.375 ID,NYLON W/ADH BACK	34785	021-0375
-49	348-0707-00		2						GROMMET,PLASTIC:BLACK,U SHAPE,0.5 X 2.0	85471	OBD
-50	407-2498-00		1						BRACKET,CRT:UPPER,AL (ATTACHING PARTS)	80009	407-2498-00
-51	212-0023-00		4						SCREW,MACHINE:0-32 X 0.375,PNH,STL CD PL -----*	83385	OBD
-52	-----		1						CKT BOARD ASSY:HARD COPY AMPL(SEE A14 REPL) (ATTACHING PARTS)		
-53	129-0457-00		2						SPACER,POST:1.07L,W/4-40 TAP 1 END -----*	80009	129-0457-00
-54	214-0506-00		2						HARD COPY BOARD INCLUDES: . CONTACT,ELEC:0.045 SQ X 0.375 INCH L	80009	214-0506-00
-55	352-0125-00		1						. HOLDER,TOROID:MOLD ACETAL	80009	352-0125-00
-56	210-1014-00		1						. WASHER,NONMETAL:0.094 ID X 0.312" OD,TEFLON	80009	210-1014-00
-57	200-2357-01		1						COVER,CKT BOARD:POLYCARBONATE (ATTACHING PARTS)	80009	200-2357-01
-58	211-0244-00		2						SCR,ASSEM WSHR:4-40 X 0.312 INCH,PNH STL -----*	78189	OBD
-59	334-2255-00		1						MARKER,IDENT:DANGER 500V	80009	334-2255-00
-60	334-1379-00		1						LABEL:CRT,ADHESIVE BACK	80009	334-1379-00

REPLACEABLE MECHANICAL PARTS

Fig. & Index No.	Tektronix Part No.	Serial/Model No. Eff Dscont	Qty	1	2	3	4	5	Name & Description	Mfr Code	Mfr Part Number
3-	-----	-----	1						CKT BOARD ASSY:HV & Z AXIS(SEE A16 REPL)		
-1	211-0513-00		1						. SCREW,MACHINE:6-32 X 0.625 INCH,PNH STL	83385	OBD
-2	210-0847-00		1						. WASHER,FLAT:0.164 ID X 0.500 OD,NYLON	83309	OBD
-3	214-2526-00		1						. SHIELD,EXP:6-32 X 0.312 INCH,PLASTIC	00613	E632
-4	334-2258-00		1						. MARKER,IDENT:DANGER HI VOLT	80009	334-2258-00
-5	337-2466-00		1						. SHIELD,ELEC:HIGH VOLTAGE (ATTACHING PARTS)	80009	337-2466-00
-6	211-0033-00		3						. SCR,ASSEM WSHR:4-40 X 0.312 PNH,STL,CD PL - - - * - - -	83385	OBD
-7	-----	-----	1						. TRANSISTOR:CHASSIS MTG(SEE A16Q53 REPL) (ATTACHING PARTS)		
-8	211-0097-00		1						. SCREW,MACHINE:4-40 X 0.312 INCH,PNH STL	83385	OBD
-9	210-1122-00		1						. WASHER,LOCK:0.12 ID,DISHED,0.025 THK - - - * - - -	86928	OBD
-10	342-0163-00		1						. INSULATOR,PLATE:XSTR,0.675 X 0.625 X 0.001"	80009	342-0163-00
-11	351-0460-00		2						. GUIDE,CKT CARD: (ATTACHING PARTS)	80009	351-0460-00
-12	211-0007-00		3						. SCREW,MACHINE:4-40 X 0.188 INCH,PNH STL - - - * - - -	83385	OBD
-13	348-0050-00		1						. GROMMET,PLASTIC:0.75 INCH DIA (NOT USED IN OPTION 31)	80009	348-0050-00
-14	337-2465-00		1						. SHIELD,ELEC:HIGH VOLTAGE (ATTACHING PARTS)	80009	337-2465-00
-15	211-0033-00		2						. SCR,ASSEM WSHR:4-40 X 0.312 PNH,STL,CD PL	83385	OBD
-16	211-0244-00		1						. SCR,ASSEM WSHR:4-40 X 0.312 INCH,PNH STL - - - * - - -	78189	OBD
-17	129-0541-00		2						. POST,ELEC-MECH:1.53" L W/4-40 THD,NYLON (ATTACHING PARTS)	80009	129-0541-00
-18	211-0244-00		2						. SCR,ASSEM WSHR:4-40 X 0.312 INCH,PNH STL - - - * - - -	78189	OBD
-19	384-1455-00		3						. EXTENSION SHAFT:1.5 L X 0.28 OD,PLASTIC	80009	384-1455-00
-20	-----	-----	1						CKT BOARD ASSY:HV & Z AXIS(SEE A16A1 REPL)		
-21	136-0759-00		1						. . SKT,PL-IN-ELEK:CRT,7 PIN W/LEADS	80009	136-0759-00
-22	136-0278-00		1						. . . SOCKET,PLUG-IN:WITH PINS	80009	136-0278-00
-22.1	204-0322-00		1						. . BODY,CRT SOCKET:7 CONTACT	80009	204-0322-00
-23	214-0464-00		7						. . . CONTACT,ELEC:CRT	80009	214-0464-00
-24	124-0118-00		1						. . . TERMINAL BOARD:1 NOTCH,CERAMIC,CLIP MTD	80009	124-0118-00
-25	361-0007-00		1						. . . SPACER,SLEEVE:0.250 INCH DIA,PLASTIC	80009	361-0007-00
-26	131-0608-00		6						. . . TERMINAL,PIN:0.365 L X 0.025 PH BRZ GOLD	22526	47357
-27	131-0993-00		2						. . . BUS,CONDUCTOR:2 WIRE BLACK	00779	530153-2
-28	344-0154-00		2						. . . CLIP,ELECTRICAL:FUSE,CKT BD MT	80009	344-0154-00
-29	131-1994-00		2						. . . CONN,RCPT,ELEC:CKT BD,10 CONTACT MALE	27264	22-16-2101
-30	214-0973-00		1						. . . HEAT SINK,ELEC:0.28 X 0.18 OVAL X 0.187"H	80009	214-0973-00
-31	343-0659-00		1						. . . CLAMP,LOOP:0.375 DIA,STEEL CAD PLATE	000CP	OBD
-32	343-0003-00		1						. . . CLAMP,LOOP:0.25 ID,PLASTIC (ATTACHING PARTS)	95987	1-4-6B
-33	211-0152-00		1						. . . SCR,ASSEM WSHR:4-40 X 0.625 INCH,PNH BRS	83385	OBD
-34	210-0863-00		1						. . . WSHR,LOOP CLAMP:0.187 ID U/W 0.5 W CLP,STL	95987	C191
-35	210-0005-00		1						. . . WASHER,LOCK:#6 EXT,0.02 THK,STL - - - * - - -	78189	1106-00
-36	337-1456-00		1						. . . SHLD,ELECTRICAL:CKT CARD MOUNT	80009	337-1456-00
-37	361-0607-00		3						. . . SPACER,SWITCH:PLASTIC	80009	361-0607-00
-38	351-0460-00		2						GUIDE,CKT CARD: (ATTACHING PARTS)	80009	351-0460-00
-39	211-0007-00		4						SCREW,MACHINE:4-40 X 0.188 INCH,PNH STL - - - * - - -	83385	OBD
-40	343-0916-00		1						CLAMP,LOOP:0.5 ID,NYLON	34785	029-500
-41	426-1709-00		1						FR,CKT BD MDL: (ATTACHING PARTS)	80009	426-1709-00
-42	212-0004-00		4						SCREW,MACHINE:8-32 X 0.312 INCH,PNH STL - - - * - - -	83385	OBD
-43	351-0512-00		3						GUIDE,CKT BOARD:WHITE NYLON,4.89L (ATTACHING PARTS)	80009	351-0512-00
-44	354-0195-00		3						RING,RETAINING: - - - * - - -	97464	6100-12-ST-PA

REPLACEABLE MECHANICAL PARTS

Fig. & Index No.	Tektronix Part No.	Serial/Model No. Eff	Dscont	Qty	1 2 3 4 5	Name & Description	Mfr Code	Mfr Part Number
3-45	214-2507-00			4		PIN, GUIDE: CIRCUIT CARD (ATTACHING PARTS)	80009	214-2507-00
-46	213-0777-00			4		SCREW, TPG, TF: 4-24 X 0.375 L, FLH, 100 DEG - - - * - - -	93907	OBD
-47	-----			1		CKT BOARD ASSY: INTERCONNECT (SEE A11 REPL)		
-48	131-0589-00			176		. TERMINAL, PIN: 0.46 L X 0.025 SQ	22526	48283-029
-49	131-1956-00			1		. TERM. SET, PIN: 8 MALE CONT, RIGHT ANGLE	00779	87233-8
-50	198-3572-00			2		WIRE SET, ELEC:	80009	198-3572-00
-51	131-0707-00			2		. CONNECTOR, TERM: 22-26 AWG, BRS& CU BE GOLD	22526	47439
-52	352-0169-00			2		. HLDR, TERM CONN: 2 WIRE BLACK	80009	352-0169-00
-53	210-0205-00			1		TERMINAL, LUG: SE #8 (ATTACHING PARTS)	86928	5442-7
-54	212-0023-00			1		SCREW, MACHINE: 0-32 X 0.375, PNH, STL CD PL - - - * - - -	83385	OBD
-55	214-2506-00			12		PIN, STR, HDLS: 0.250 DIA X 1.450 L, AL	80009	214-2506-00
-56	361-0822-00			12		SPACER, SLEEVE: 0.3 L X 0.148 ID, AL	80009	361-0822-00
-57	211-0033-00			12		SCR, ASSEM WSHR: 4-40 X 0.312 PNH, STL, CD PL	83385	OBD
-58	255-0334-00			1		PLASTIC CHANNEL: 12.75 X 0.175 X 0.155, NYL	11897	122-37-2500
-59	198-4332-00			1		WIRE SET, ELEC:	80009	198-4332-00
-60	175-0829-00			1		. WIRE, ELECTRICAL: 6 WIRE RIBBON	08261	SS-0626-710610C
-61	131-0621-00			22		. . CONNECTOR, TERM: 22-26 AWG, BRS& CU BE GOLD	22526	46231
	131-0622-00			1		. . CONTACT, ELEC: 0.577"L, 28-32 AWG WIRE	22526	46241
	131-0792-00			3		. . CONNECTOR, TERM: 18-20 AWG, CU BE GOLD PL	22526	46221
-62	352-0203-02			1		. . CONN BODY, PL, EL: 7 WIRE ORANGE	80009	352-0203-02
-63	352-0203-04			1		. . CONN BODY, PL, EL: 7 WIRE YELLOW	80009	352-0203-04
-64	175-0828-00			1		. . WIRE, ELECTRICAL: 5 WIRE RIBBON	08261	SS-0526-710610C
-65	352-0201-01			1		. . CONN BODY, PL, EL: 5 WIRE BROWN	80009	352-0201-01
-66	352-0201-03			1		. . CONN BODY, PL, EL: 5 WIRE ORANGE	80009	352-0201-03
-67	177-1183-00			AR		. . CABLE, RF: 50 OHM COAX, 9-0	80009	177-1183-00
-68	131-0708-00			1		. . CONTACT, ELEC: 0.48"L, 28-32 AWG WIRE	22526	47437
	131-2428-00			1		. . CONN PLUG, ELEC: 18-20 AWG, BRS& CU BE GOLD	22526	47441
-69	352-0169-00			1		. . HLDR, TERM CONN: 2 WIRE BLACK	80009	352-0169-00
-70	352-0198-00			1		. . HLDR, TERM CONN: 2 WIRE BLACK	80009	352-0198-00
	-----			1		CKT BOARD ASSY: STORAGE (SEE A13 REPL)		
-71	214-2508-00	B010100	B010169	1		. HT SK, CKT CARD:	80009	214-2508-00
	214-2508-01	B010170		1		. HEAT SINK, ELEC: CIRCUIT BOARD, AL (ATTACHING PARTS)	80009	214-2508-01
-72	211-0551-00			2		SCREW, MACHINE: 6-32 X 0.562 INCH, PNH STL - - - * - - -	83385	OBD
	-----			-		DOUBLE ERASE STORAGE ASSY INCLUDES:		
-73	-----			8		. TRANSISTOR: (SEE A13Q15, 25, 35, 45, 55, - . 65, 75, 85) (ATTACHING PARTS)		
-74	211-0033-00	B010100	B010169	8		. SCR, ASSEM WSHR: 4-40 X 0.312 PNH, STL, CD PL	83385	OBD
	211-0246-00	B010170		8		. SCR, ASSEM WSHR: 4-40 X 0.625 INCH, PNH, STL	78189	OBD
-75	210-0994-00	B010100	B010169X	8		. WASHER, FLAT: 0.125 ID X 0.25" OD, STL	86928	5702-201-20
-76	210-1291-00	B010100	B010169X	8		. WASHER, SHLDR: 0.118 ID X 0.1 THK, PLSTC	80009	210-1291-00
-77	342-0451-00	B010100	B010169	8		. INSULATOR, PLATE: TRANSISTOR, KAPTON	08530	OBD
	342-0536-00	B010170		8		. INSULATOR, XSTR: TO-220, POLYENELENE	80009	342-0536-00
	342-0563-00	XB010170		8		. INSULATOR, PLATE: TRANSISTOR, FIBERGLAS - - - * - - -	18565	OBD
-78	351-0460-00			3		. GUIDE, CKT CARD: (ATTACHING PARTS)	80009	351-0460-00
-79	211-0007-00			6		. SCREW, MACHINE: 4-40 X 0.188 INCH, PNH STL - - - * - - -	83385	OBD
-80	-----			1		. CKT BOARD ASSY: STORAGE (SEE A13A1 REPL) (ATTACHING PARTS)		
-81	211-0033-00			3		. SCR, ASSEM WSHR: 4-40 X 0.312 PNH, STL, CD PL - - - * - - -	83385	OBD
	-----			-		DOUBLE ERASE STORAGE BOARD INCLUDES:		
-82	131-0608-00			9		. . TERMINAL, PIN: 0.365 L X 0.025 PH BRZ GOLD	22526	47357
-83	131-0993-00			3		. . BUS, CONDUCTOR: 2 WIRE BLACK	00779	530153-2
-84	131-1994-00			2		. . CONN, RCPT, ELEC: CKT BD, 10 CONTACT MALE	27264	22-16-2101
-85	131-1995-00			1		. . CONN, RCPT, ELEC: CKT BD, 15 CONTACT MALE	27264	22-16-2151
-86	131-2131-00			1		. . CONN, RCPT, ELEC: CKT CD, 5 CONT, RIGHT ANGLE	27264	22-16-2051
-87	214-0579-00			1		. . TERM, TEST POINT: BRS CD PL	80009	214-0579-00

REPLACEABLE MECHANICAL PARTS

Fig. & Index No.	Tektronix Part No.	Serial/Model No. Eff Dscont	Qty	1	2	3	4	5	Name & Description	Mfr Code	Mfr Part Number
3-88	407-2524-00		1						BRACKET, ANGLE: (ATTACHING PARTS)	80009	407-2524-00
-89	213-0183-00		1						SCR, TPG, THD FOR: 6-20 X 0.5 TYPE B, PNH, STL	83385	OBD
-90	210-0458-00		1						NUT, PL, ASSEM WA: 8-32 X 0.344 INCH, STL	83385	OBD
	-----								----- * -----		
			1						CKT BOARD ASSY: DEFLECTION AMPL (SEE A15 REPL)		
-91	214-2612-00		1						. HT SK, CKT CD: ALUMINUM	80009	214-2612-00
									(ATTACHING PARTS)		
-92	211-0551-00		4						SCREW, MACHINE: 6-32 X 0.562 INCH, PNH STL	83385	OBD
	-----								----- * -----		
			-						DEFLECTION AMP ASSY INCLUDES:		
-93	-----		4						. TRANSISTOR: (SEE A15Q30, 40, 60, 90 REPL)		
	-----		4						. TRANSISTOR: (SEE A15Q20, 50, 70, 80 REPL)		
									(ATTACHING PARTS)		
-94	211-0033-00		8						. SCR, ASSEM WSHR: 4-40 X 0.312 PNH, STL, CD PL	83385	OBD
-95	210-0994-00		8						. WASHER, FLAT: 0.125 ID X 0.25" OD, STL	86928	5702-201-20
-96	210-1291-00		8						. WASHER, SHLDR: 0.118 ID X 0.1 THK, PLSTC	80009	210-1291-00
-97	342-0311-00		8						. INSULATOR, PLATE: TRANSISTOR, MICA	01295	64-21-023-212
									----- * -----		
-98	351-0460-00		3						. GUIDE, CKT CARD:	80009	351-0460-00
									(ATTACHING PARTS)		
-99	211-0007-00		6						. SCREW, MACHINE: 4-40 X 0.188 INCH, PNH STL	83385	OBD
	-----								----- * -----		
-100	-----		1						. CKT BOARD ASSY: DEFLECTION AMPL (SEE A15A1 REPL)		
									(ATTACHING PARTS)		
-101	211-0244-00		3						. SCR, ASSEM WSHR: 4-40 X 0.312 INCH, PNH STL	78189	OBD
	-----								----- * -----		
			-						. DEFLECTION AMP BOARD INCLUDES:		
-102	131-0993-00		2						. . . BUS, CONDUCTOR: 2 WIRE BLACK	00779	530153-2
-103	131-0859-00		6						. . . CONN, PLUG, ELEC: PWR, 125VAC, 15A W/TWIST	000AD	7594
-104	131-1207-00		1						. . . LINK, TERM. CONNE: 4 WIRE BLACK	80009	131-1207-00
-105	352-0162-00		1						. . . HLDR, TERM CONN: 4 WIRE BLACK	80009	352-0162-00
-106	131-0707-00		4						. . . CONNECTOR, TERM: 22-26 AWG, BRS& CU BE GOLD	22526	47439
-107	131-1994-00		1						. . . CONN, RCPT, ELEC: CKT BD, 10 CONTACT MALE	27264	22-16-2101
-108	131-1995-00		2						. . . CONN, RCPT, ELEC: CKT BD, 15 CONTACT MALE	27264	22-16-2151
-109	136-0729-00		1						. . . SKT, PL-IN ELEK: MICROCKT, 16 CONTACT	09922	DILB16P-108T
-110	198-3443-00		2						. . . WIRE SET, ELEC:	80009	198-3443-00
-111	352-0198-00		2						. . . HLDR, TERM CONN: 2 WIRE BLACK	80009	352-0198-00
-112	131-0621-00		4						. . . CONNECTOR, TERM: 22-26 AWG, BRS& CU BE GOLD	22526	46231
-113	175-3175-00		1						CA ASSY, SP, ELEC: 1, 50 OHM COAX, 2, 26 AWG	000IK	OBD
-114	358-0458-00		1						BSHG, STRAIN RLF: U/W 0.43 DIA CABLE	28520	SR-7P-2
-115	131-0890-00		2						LOCK, CONNECTOR: 4-40 X 0.312 L	71468	D 20418-2
-116	343-0013-00	B010100 B010399	3						CLAMP, LOOP: 0.375 INCH DIA	95987	3-8-6B
	343-0006-00	B010400	3						CLAMP, LOOP: 0.50 INCH DIAMETER, PLSTC	95987	1-2-6B
									(ATTACHING PARTS)		
-117	210-0457-00		3						NUT, PL, ASSEM WA: 6-32 X 0.312, STL CD PL	83385	OBD
-118	210-0863-00		3						WSHR, LOOP CLAMP: 0.187 ID U/W 0.5 W CLP, STL	95987	C191
									----- * -----		
-119	198-4310-00		1						WIRE SET, ELEC:	80009	198-4310-00
-120	131-0707-00		8						. . . CONNECTOR, TERM: 22-26 AWG, BRS& CU BE GOLD	22526	47439
	131-2428-00		3						. . . CONN PLUG, ELEC: 18-20 AWG, BRS& CU BE GOLD	22526	47441
	131-0708-00		2						. . . CONTACT, ELEC: 0.48"L, 28-32 AWG WIRE	22526	47437
-121	131-0458-00		1						. . . CONNECTOR, RCPT, : 15 PIN, FEMALE	71468	DA15S
-122	210-0202-00		2						. . . TERMINAL, LUG: 0.146 ID, LOCKING, BRZ TINNED	78189	2104-06-00-2520N
-123	352-0162-00		1						. . . HLDR, TERM CONN: 4 WIRE BLACK	80009	352-0162-00
-124	352-0167-00		1						. . . HLDR, TERM CONN: 9 WIRE BLACK	80009	352-0167-00
-125	343-0549-00		4						. STRAP, TIEDOWN: 0.091 W X 3.62 INCH LONG	59730	TY100
-126	210-0863-00		1						WSHR, LOOP CLAMP: 0.187 ID U/W 0.5 W CLP, STL	95987	C191
-127	441-1556-00		1						CHASSIS, TERM: INTERCONNECT MODULE	80009	441-1556-00
									(ATTACHING PARTS)		
-128	212-0023-00		3						SCREW, MACHINE: 0-32 X 0.375, PNH, STL CD PL	83385	OBD
									----- * -----		

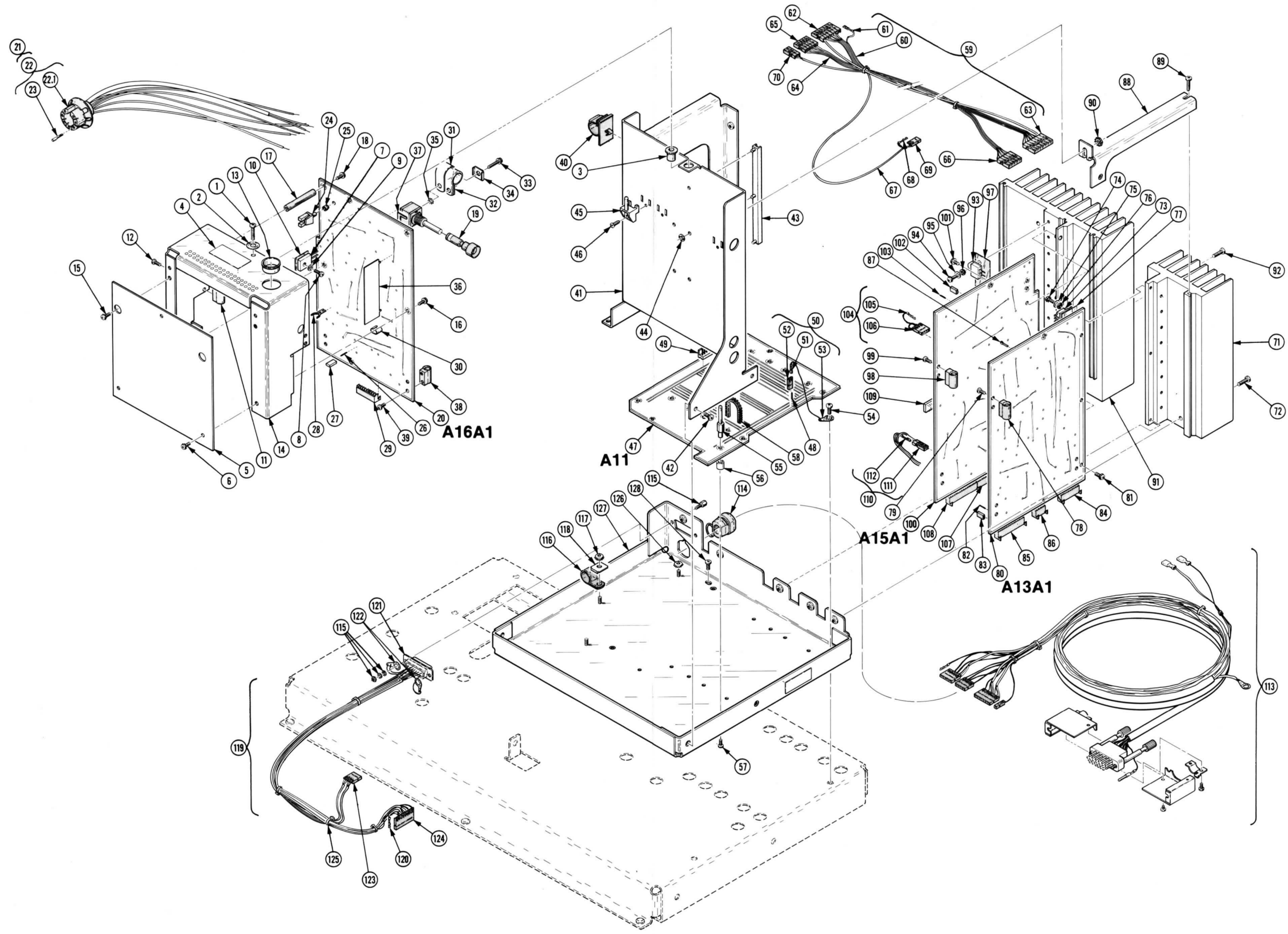
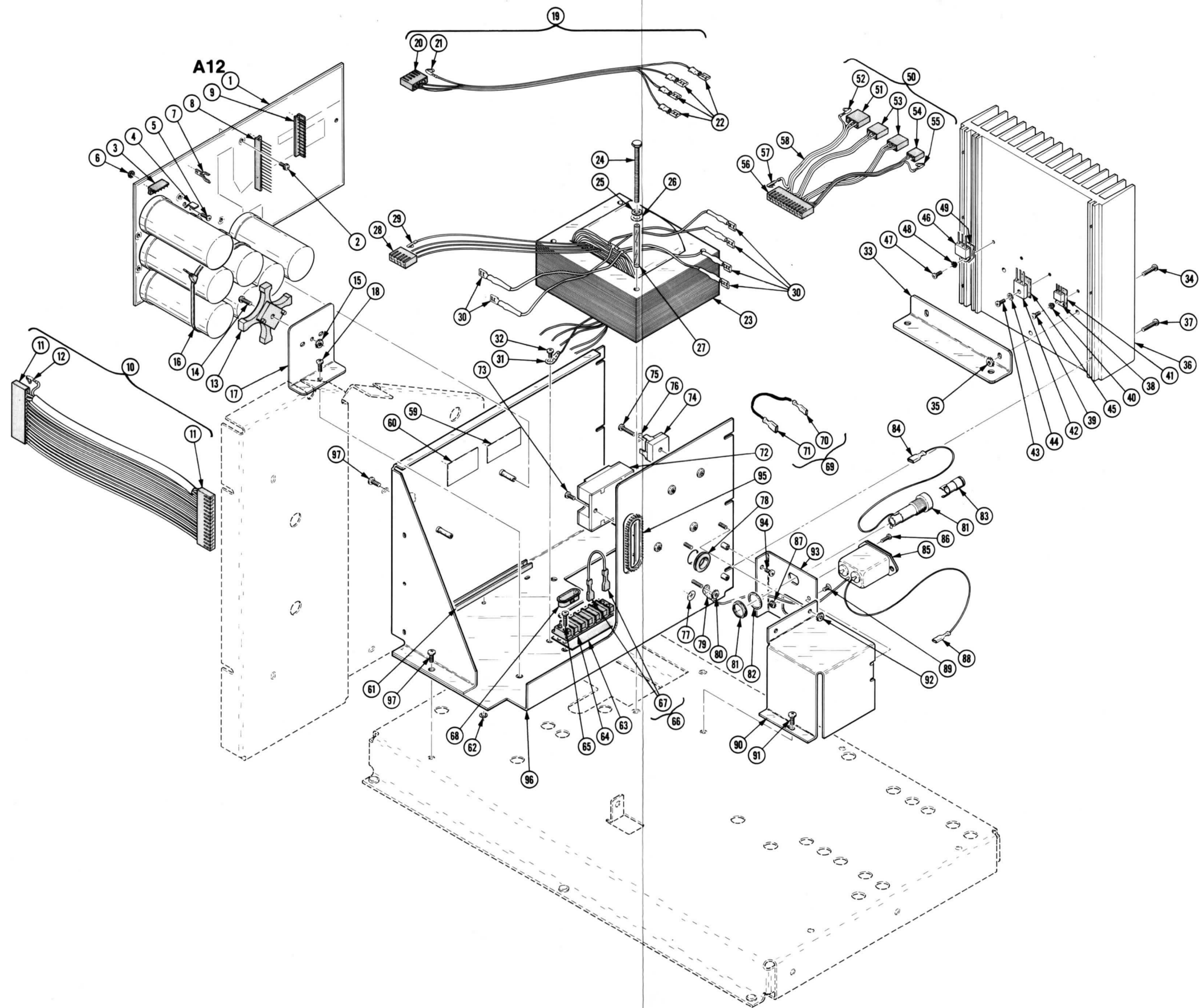

FIG. 3 INTERCONNECT MODULE

FIG. 4 DISPLAY POWER SUPPLY



REPLACEABLE MECHANICAL PARTS

Fig. & Index No.	Tektronix Part No.	Serial/Model No. Eff Dscont	Qty	1	2	3	4	5	Name & Description	Mfr Code	Mfr Part Number
4-1	-----		1						CKT BOARD ASSY:LV PWR SUPPLY(SEE A12 REPL) (ATTACHING PARTS)		
-2	211-0244-00		2						SCR,ASSEM WSHR:4-40 X 0.312 INCH,PNH STL - - - * - - -	78189	OBD
-3	131-1974-00		2						LVPS BOARD ASSY INCLUDES: . TERM. SET,PIN:5 MALE CONTACTS	000CA	09-60-1051
-4	131-1816-00		2						. TERM,QIK DISC.:0.25 X 0.315 X 0.032 DOUBLE (ATTACHING PARTS)	00779	41480
-5	210-0008-00		2						. WASHER,LOCK:INTL,0.172 ID X 0.331"OD,STL	78189	1208-00-00-0541C
-6	210-0586-00		2						. NUT,PL,ASSEM WA:4-40 X 0.25,STL CD PL - - - * - - -	83385	OBD
-7	344-0154-00		14						. CLIP,ELECTRICAL:FUSE,CKT BD MT	80009	344-0154-00
-8	131-1976-00		1						. TERM. SET,PIN:15 MALE CONT	27264	09-60-1151
-9	131-1975-00		1						. TERM. SET,PIN:12 MALE CONTACTS	27264	09-60-1121
-10	175-2684-00		1						CA ASSY,SP,ELEC:15,20 AWG,17.0 L	80009	175-2684-00
-11	204-0751-00		2						. CONN BODY,PLUG:CKT CD,15 CONT,W/O LKG RAMP	27264	09-50-3151
-12	131-1790-00		30						. CONTACT,ELEC:18-24 AWG,FEMALE,BRASS	27264	08-56-0105
-13	361-0143-00		1						WASHER,KEY:0.281 ID X 0.562 INCH OD (ATTACHING PARTS)	80009	361-0143-00
-14	211-0510-00		1						SCREW,MACHINE:6-32 X 0.375,PNH,STL,CD PL	83385	OBD
-15	210-0457-00		1						NUT,PL,ASSEM WA:6-32 X 0.312,STL CD PL - - - * - - -	83385	OBD
-16	346-0143-00		1						STRAP,TIEDOWN:14.5 X 0.14 INCH,PLASTIC	59730	TY-244-M
-17	407-1899-00		1						BRACKET,CAP.:ALUMINUM (ATTACHING PARTS)	80009	407-1899-00
-18	211-0507-00		1						SCREW,MACHINE:6-32 X 0.312 INCH,PNH STL - - - * - - -	83385	OBD
-19	175-3595-00		1						CA ASSY,SP,ELEC:4,18 AWG,13.0L,RIBBON	80009	175-3595-00
-20	204-0749-00		1						. CONN BODY,PLUG:CKT CD,5 CONTW/O LKG RAMP	27264	2139-052
-21	131-1790-00		4						. CONTACT,ELEC:18-24 AWG,FEMALE,BRASS	27264	08-56-0105
-22	131-1215-00		4						. TERM,QIK DISC:U/W 0.25 X 0.032 TAB,RED	77342	42599-4
-23	-----		1						TRANSFORMER:(SEE T1001 REPL) (ATTACHING PARTS)		
-24	212-0522-00		4						SCREW,MACHINE:10-32 X 2.50",HEX HD STL	83385	OBD
-25	210-0812-00		4						WASHER,NONMETAL:#10,FIBER	86445	OBD
-26	210-1003-00		2						WASHER,FLAT:# 10 X 0.036 THICK,BRS	12327	OBD
-27	166-0457-00		4						INSUL SLVG,ELEC:0.19 ID X 1.875"LONG MYLAR - - - * - - -	80009	166-0457-00
-28	204-0749-00		1						. TRANSFORMER ASSY INCLUDES: . CONN BODY,PLUG:CKT CD,5 CONTW/O LKG RAMP	27264	2139-052
-29	131-1918-00		4						. CONTACT,ELEC:22-26 AWG WIRE,CRIMP ON,BRS	27264	08-56-0107
-30	131-1159-00		6						. TERM,QIK DISC.:14-18 AWG,U/WO.25 X 0.032	00779	42660-2
-31	210-0202-00		1						TERMINAL,LUG:0.146 ID,LOCKING,BRZ TINNED (NOT USED IN OPTION 31) (ATTACHING PARTS)	78189	2104-06-00-2520N
-32	211-0507-00		1						SCREW,MACHINE:6-32 X 0.312 INCH,PNH STL - - - * - - -	83385	OBD
-33	407-2077-00		1						BRACKET,ANGLE:LOW VOLTAGE HEAT SINK (ATTACHING PARTS)	80009	407-2077-00
-34	211-0513-00		2						SCREW,MACHINE:6-32 X 0.625 INCH,PNH STL	83385	OBD
-35	210-0457-00		2						NUT,PL,ASSEM WA:6-32 X 0.312,STL CD PL - - - * - - -	83385	OBD
-36	214-2509-00		1						HT SK,PWR SPLY:LOW VOLTAGE (ATTACHING PARTS)	80009	214-2509-00
-37	213-0185-00		6						SCR,TPG,THD FOR:6-20 X 6.25 INCH,PNH STL - - - * - - -	83385	OBD
-38	-----		1						MICROCIRCUIT:(SEE U1002 REPL) (ATTACHING PARTS)		
-39	211-0097-00		1						SCREW,MACHINE:4-40 X 0.312 INCH,PNH STL	83385	OBD
-40	210-1291-00		1						WASHER,SHLDR:0.118 ID X 0.1 THK,PLSTC	80009	210-1291-00
-41	342-0202-00		1						INSULATOR,PLATE:TRANSISTOR - - - * - - -	01295	10-21-023-106
-42	-----		2						TRANSISTOR:(SEE Q1002,Q1003 REPL) (ATTACHING PARTS)		
-43	211-0097-00		2						SCREW,MACHINE:4-40 X 0.312 INCH,PNH STL	83385	OBD
-44	210-1122-00		2						WASHER,LOCK:0.12 ID,DISHED,0.025 THK	86928	OBD
-45	342-0163-00		2						INSULATOR,PLATE:XSTR,0.675 X 0.625 X 0.001" - - - * - - -	80009	342-0163-00

REPLACEABLE MECHANICAL PARTS

Fig. & Index No.	Tektronix Part No.	Serial/Model No. Eff Dscont	Qty	1	2	3	4	5	Name & Description	Mfr Code	Mfr Part Number
4-46	-----		1						TRANSISTOR:(SEE Q1001 REPL) (ATTACHING PARTS)		
-47	211-0097-00		1						SCREW,MACHINE:4-40 X 0.312 INCH,PNH STL	83385	OBD
-48	210-1291-00		1						WASHER,SHLDR:0.118 ID X 0.1 THK,PLSTC	80009	210-1291-00
-49	342-0311-00		1						INSULATOR,PLATE:TRANSISTOR,MICA	01295	64-21-023-212
									- - - - * - - - -		
-50	198-4333-00		1						WIRE SET,ELEC:	80009	198-4333-00
-51	352-0463-00		1						. HLDR,TERM.CONN:3 FEMALE,NYLON	27264	10-01-1034
-52	131-1918-00		3						. CONTACT,ELEC:22-26 AWG WIRE,CRIMP ON,BRS	27264	08-56-0107
-53	204-0671-00		2						. CONN BODY,PLUG:1 X 3 CONTACTS NYLON	27264	09-50-7031
-54	204-0678-00		1						. CONN BODY,PL,EL:FOR 3 FEMALE CONTACTS	27264	10-17-2032
-55	131-1815-00		3						. CONTACT,ELEC:22-30 AWG,FEMALE,BRASS	27264	08-56-0110
-56	352-0461-00		1						. HLDR,TERM. CONN:12 FEMALE,NYLON	27264	09-50-7121
-57	131-1790-00		12						. CONTACT,ELEC:18-24 AWG,FEMALE,BRASS	27264	08-56-0105
-58	175-0862-00		AR						. WIRE,ELECTRICAL:3 WIRE RIBBON	08261	SS-0322-1910610C
-59	334-2255-00		2						MARKER,IDENT: DANGER 500V	80009	334-2255-00
-60	334-2859-00		1						MARKER,IDENT:MARKED CAUTION	22670	OBD
-61	351-0512-00		2						GUIDE,CKT BOARD:WHITE NYLON,4.89L (ATTACHING PARTS)	80009	351-0512-00
-62	354-0195-00		2						RING,RETAINING:	97464	6100-12-ST-PA
									- - - - * - - - -		
-63	334-3266-00		1						PLATE,DES:MARKED 1 THRU5	13130	VF-14005-103
-64	124-0385-00		1						TERMINAL BOARD:5 CONTACT (ATTACHING PARTS)	10112	760505XX000B
-65	211-0511-00		2						SCREW,MACHINE:6-32 X 0.500,PNH,STL,CD PL	83385	OBD
									- - - - * - - - -		
-66	195-1498-00		2						LEAD,ELECTRICAL:18 AWG,3.0 L,8-N	80009	195-1498-00
-67	131-2065-00		4						. TERM,QIK DISC:18-22 AWG,BRASS TIN PLATED	00779	2-520181-2
-68	348-0253-00		1						GROMMET,PLASTIC:BLACK,OBLONG,3.OXO.925	80009	348-0253-00
-69	198-1418-00		1						WIRE SET,ELEC:	80009	198-1418-00
-70	131-2065-00		1						. TERM,QIK DISC:18-22 AWG,BRASS TIN PLATED	00779	2-520181-2
-71	131-2435-00		1						. TERM,QIK DISC:FEMALE,18-22 AWG	00779	2-520183-2
-72	-----		1						RELAY,SOLID STATE:(SEE U1001 REPL) (ATTACHING PARTS)		
-73	211-0507-00		2						SCREW,MACHINE:6-32 X 0.312 INCH,PNH STL	83385	OBD
									- - - - * - - - -		
-74	-----		2						SEMICONV DEVICE:(SEE CR1005,CR1006 REPL) (ATTACHING PARTS)		
-75	211-0513-00		2						SCREW,MACHINE:6-32 X 0.625 INCH,PNH STL	83385	OBD
-76	210-0071-00		2						WASHER,SPR TNSN:0.146 ID X 0.323" OD,STL	78189	4706-05-01-0531
									- - - - * - - - -		
-77	334-3379-00		1						MARKER,IDENT:MARKED GROUND SYMBOL	80009	334-3379-00
-78	348-0012-00		1						GROMMET,RUBBER:0.625 INCH DIA	72653	1043-1M
-79	210-0202-00		1						TERMINAL,LUG:0.146 ID,LOCKING,BRZ TINNED (ATTACHING PARTS)	78189	2104-06-00-2520N
-80	210-0457-00		1						NUT,PL,ASSEM WA:6-32 X 0.312,STL CD PL	83385	OBD
									- - - - * - - - -		
-81	204-0832-00		1						BODY,FUSEHOLDER:3AG,5 X 20MM FUSES	S3629	031.1673(MDLFEU)
-82	210-1039-00		1						WASHER,LOCK:INT,0.521 ID X 0.625 INCH OD	24931	OBD
-83	200-2264-00		1						CAP.,FUSEHOLDER:3AG FUSES	S3629	FEK 031 1666
-84	131-2435-00		1						TERM,QIK DISC:FEMALE,18-22 AWG	00779	2-520183-2
-85	119-0420-00		1						FILTER,RFI:6A,250VAC,400HZ (J5001)	02777	F-11935-6
									(ATTACHING PARTS)		
-86	211-0012-00		2						SCREW,MACHINE:4-40 X 0.375,PNH STL CD PL	83385	OBD
-87	210-0586-00		2						NUT,PL,ASSEM WA:4-40 X 0.25,STL CD PL	83385	OBD
									- - - - * - - - -		
-88	131-2065-00		1						TERM,QIK DISC:18-22 AWG,BRASS TIN PLATED	00779	2-520181-2
-89	211-0538-00		1						SCREW,MACHINE:6-32 X 0.312"100 DEG,FLH STL	83385	OBD
-90	200-2567-00		1						COV,CMPNT BRKT:ALUMINUM (ATTACHING PARTS)	80009	200-2567-00
-91	212-0023-00		1						SCREW,MACHINE:0-32 X 0.375,PNH,STL CD PL	83385	OBD
-92	210-0457-00		2						NUT,PL,ASSEM WA:6-32 X 0.312,STL CD PL	83385	OBD
									- - - - * - - - -		

REPLACEABLE MECHANICAL PARTS

Fig. & Index No.	Tektronix Part No.	Serial/Model No. Eff Dscont	Qty	1 2 3 4 5	Name & Description	Mfr Code	Mfr Part Number
4-93	407-2522-00		1		BRACKET,CMPNT:FUSE & LINE VOLT CONN,AL (ATTACHING PARTS)	80009	407-2522-00
-94	211-0507-00		2		SCREW,MACHINE:6-32 X 0.312 INCH,PNH STL - - - * - - -	83385	OBD
-95	255-0334-00		AR		PLASTIC CHANNEL:12.75 X 0.175X 0.155,NYL	11897	122-37-2500
-96	441-1524-00		1		CHASSIS,TERM:LV POWER SUPPLY (ATTACHING PARTS)	80009	441-1524-00
-97	212-0023-00		4		SCREW,MACHINE:0-32 X 0.375,PNH,STL CD PL - - - * - - -	83385	OBD

REPLACEABLE MECHANICAL PARTS

Fig. & Index No.	Tektronix Part No.	Serial/Model No. Eff Dscont	Qty	1	2	3	4	5	Name & Description	Mfr Code	Mfr Part Number
5-1	-----	-----	1						KEYBOARD ASSEMBLY(SEE A4 REPL) (ATTACHING PARTS)		
-2	211-0514-00		5						SCREW,MACHINE:6-32 X 0.750 INCH,PNH STL - - - * - - -	83385	OBD
	-----	-----	-						KEYBOARD ASSY INCLUDES:		
-3	-----	-----	-						. SCREWS		
-4	-----	-----	-						. SCREWS		
-5	118-0968-00		1						. SPACER,LED:	51181	47-C0198-007
-5.1	-----	-----	4						LT EMITTING DIO:(SEE A4DS1,DS2,DS3,DS4 REPL)		
-6	366-1884-00		8						. PUSH BUTTON:EARTH BROWN,BLANK	52833	CZCZ01R110900000
	260-2062-00		8						. SW,CAPACITIVE:LOW PROFILE	52833	61-04001-001
	214-3241-00		8						. SPRING,HLCPS:0.4 ID X 0.875 L	52833	45-00021-015
-7	366-1942-00		4						. PUSH BUTTON:EARTH BROWN,BLANK	52833	CZRS92R110902043
	260-2061-00		4						. SW,CAPACITIVE:LOW PROFILE	52833	61-04005-001
	214-3240-00		4						. SPRING,HLCPS:0.31 ID X 0.64 L	52833	45-00021-060
	260-2062-00		1						. SW,CAPACITIVE:LOW PROFILE	52833	61-04001-001
	214-3241-00		1						. SPRING,HLCPS:0.4 ID X 0.875 L	52833	45-00021-015
-9	366-1940-00		1						. PUSH BUTTON:SMOKE TAN,LEFT BRACE	52833	CYBB01T110850802
	-----	-----	-						. (STANDARD AND OPTION 4A ONLY)		
	366-1945-00		1						. PUSH BUTTON:SMOKE TAN,SWEDISH		
	-----	-----	-						. (OPTION 4C,4F ONLY)		
	366-2010-00		1						. PUSH BUTTON:SMOKE TAN,L TACK/R TACK/BRA	52833	CYXD01T196703439
	-----	-----	-						. (OPTION 4E ONLY)		
	260-2062-00		1						. SW,CAPACITIVE:LOW PROFILE	52833	61-04001-001
	214-3337-00		1						. SPRING,HLCPS:0.4 ID X 0.875 L	52833	45-00021-015
-10	366-1939-00		1						. PUSH BUTTON:SMOKE TAN,! OVER 1	52833	CYBB01T137010801
	366-1961-00		1						. PUSH BUTTON:SMOKE TAN,DIARESIS/1/ - . (OPTION 4E ONLY)	52833	CYXD01T134013440
	-----	-----	-						. (OPTION 4E ONLY)		
	260-2062-00		1						. SW,CAPACITIVE:LOW PROFILE	52833	61-04001-001
	214-3337-00		1						. SPRING,HLCPS:0.4 ID X 0.875 L	52833	45-00021-015
-11	366-1938-00		1						. PUSH BUTTON:SMOKE TAN,@ OVER 2 - . (STANDARD AND OPTION 4A ONLY)	52833	CYBB01T137220801
	-----	-----	-						. (OPTION 4E ONLY)		
	366-2006-00		1						. PUSH BUTTON:SMOKE TAN,"/2		
	-----	-----	-						. (OPTION 4C,4F ONLY)		
	366-1960-00		1						. PUSH BUTTON:SMOKE TAN,-/2/&	52833	CYXD01T134023987
	-----	-----	-						. (OPTION 4E ONLY)		
	260-2062-00		1						. SW,CAPACITIVE:LOW PROFILE	52833	61-04001-001
	214-3337-00		1						. SPRING,HLCPS:0.4 ID X 0.875 L	52833	45-00021-015
-12	366-1937-00		1						. PUSH BUTTON:SMOKE TAN,# OVER 3 - . (STANDARD AND OPTION 4C,4F ONLY)	52833	CYBB01T137030801
	-----	-----	-						. (OPTION 4E ONLY)		
	366-1943-00		1						. PUSH BUTTON:SMOKE TAN,UNITED KINGDOM	52833	CYBB01T136930801
	-----	-----	-						. (OPTION 4A ONLY)		
	260-2062-00		1						. SW,CAPACITIVE:LOW PROFILE	52833	61-04001-001
	214-3337-00		1						. SPRING,HLCPS:0.4 ID X 0.875 L	52833	45-00021-015
-13	366-1936-00		1						. PUSH BUTTON:SMOKE TAN,# OVER 4	52833	CYBB01T137040801
	366-1963-00		1						. PUSH BUTTON:SMOKE TAN,EQUAL TO OR LESS - . (OPTION 4E ONLY)	52833	CYXD01T126513441
	-----	-----	-						. (OPTION 4E ONLY)		
	260-2062-00		1						. SW,CAPACITIVE:LOW PROFILE	52833	61-04001-001
	214-3337-00		1						. SPRING,HLCPS:0.4 ID X 0.875 L	52833	45-00021-015
-14	366-1889-00		1						. PUSH BUTTON:SMOKE TAN,% OVER 5	52833	CYBB01T137050801
	366-1964-00		1						. PUSH BUTTON:SMOKE TAN,=/5/% - . (OPTION 4E ONLY)	52833	CYSD01T134053441
	-----	-----	-						. (OPTION 4E ONLY)		
	260-2062-00		1						. SW,CAPACITIVE:LOW PROFILE	52833	61-04001-001
	214-3337-00		1						. SPRING,HLCPS:0.4 ID X 0.875 L	52833	45-00021-015
-15	366-1935-00		1						. PUSH BUTTON:SMOKE TAN,CARET OVER 6	52833	CYBB01T136160801
	366-1946-00		1						. PUSH BUTTON:SMOKE TAN,SWEDISH & OVER 6 - . (OPTION 4C,4F ONLY)		
	-----	-----	-						. (OPTION 4C,4F ONLY)		
	366-1965-00		1						. PUSH BUTTON:SMOKE TAN,EQUAL TO OR GREAT	52833	CYXD01T134063441
	-----	-----	-						. (OPTION 4E ONLY)		
	260-2062-00		1						. SW,CAPACITIVE:LOW PROFILE	52833	61-04001-001
	214-3337-00		1						. SPRING,HLCPS:0.4 ID X 0.875 L	52833	45-00021-015
-16	366-1934-00		1						. PUSH BUTTON:SMOKE TAN,& OVER 7	52833	CYBB01T137270801
	366-1947-00		1						. PUSH BUTTON:SMOKE TAN,SWEDISH,/ OVER 7 - . (OPTION 4C,4F ONLY)		
	-----	-----	-						. (OPTION 4C,4F ONLY)		
	366-1966-00		1						. PUSH BUTTON:SMOKE TAN,>/>/&	52833	CYXD01T128253441
	-----	-----	-						. (OPTION 4E ONLY)		

REPLACEABLE MECHANICAL PARTS

Fig. & Index No.	Tektronix Part No.	Serial/Model No. Eff Dscont	Qty	1	2	3	4	5	Name & Description	Mfr Code	Mfr Part Number
-5	260-2062-00		1	.	SW,CAPACITIVE:LOW PROFILE					52833	61-04001-001
	214-3337-00		1	.	SPRING,HLCPS:0.4 ID X 0.875 L					52833	45-00021-015
-17	366-1933-00		1	.	PUSH BUTTON:SMOKE TAN,* OVER 8					52833	CYBB01T137180801
	366-1948-00		1	.	PUSH BUTTON:SMOKE TAN,SWEDISH,(OVER 8						
	-----		1	.	(OPTION 4C,4F ONLY)						
	366-1970-00		1	.	PUSH BUTTON:SMOKE TAN,NOTEQUAL/8/*					52833	CYXD01T134083441
	-----		-	.	(OPTION 4E ONLY)						
	260-2062-00		1	.	SW,CAPACITIVE:LOW PROFILE					52833	61-04001-001
	214-3337-00		1	.	SPRING,HLCPS:0.4 ID X 0.875 L					52833	45-00021-015
-18	366-1932-00		1	.	PUSH BUTTON:SMOKE TAN,(OVER 9					52833	CYBB01T137290801
	366-1949-00		1	.	PUSH BUTTON:SMOKE TAN,) OVER 9						
	-----		-	.	(OPTION 4C,4F ONLY)						
	366-1968-00		1	.	PUSH BUTTON:SMOKE TAN,OR/9/C					52833	CYXD01T118313441
	-----		-	.	(OPTION 4E ONLY)						
	260-2062-00		1	.	SW,CAPACITIVE:LOW PROFILE					52833	61-04001-001
	214-3337-00		1	.	SPRING,HLCPS:0.4 ID X 0.875 L					52833	45-00021-015
-19	366-1931-00		1	.	PUSH BUTTON:SMOKE TAN,) OVER 0					52833	CYBB01T137900801
	366-1950-00		1	.	PUSH BUTTON:SMOKE TAN,SWEDISH,= OVER 0						
	-----		-	.	(OPTION 4C,4F ONLY)						
	366-1967-00		1	.	PUSH BUTTON:SMOKE TAN,CARET/0/					52833	CYXD01T196713441
	-----		-	.	(OPTION 4E ONLY)						
	260-2062-00		1	.	SW,CAPACITIVE:LOW PROFILE					52833	61-04001-001
	214-3337-00		1	.	SPRING,HLCPS:0.4 ID X 0.875 L					52833	45-00021-015
-20	366-1944-00		1	.	PUSH BUTTON:SMOKE TAN,DASH OVER HYPHEN					52833	CYBB01T110520802
	366-1951-00		1	.	PUSH BUTTON:SMOKE TAN,SWEDISH,? OVER +						
	-----		-	.	(OPTION 4C,4F ONLY)						
	366-1969-00		1	.	PUSH BUTTON:SMOKE TAN,-/+& UNDERSCORE					52833	CYXD01T117003439
	-----		-	.	(OPTION 4E ONLY)						
	260-2062-00		1	.	SW,CAPACITIVE:LOW PROFILE					52833	61-04001-001
	214-3337-00		1	.	SPRING,HLCPS:0.4 ID X 0.875 L					52833	45-00021-015
-21	366-1899-00		1	.	PUSH BUTTON:SMOKE TAN,+ OVER =					52833	CYBB01T111270802
	-----		-	.	(STANDARD AND OPTION 4A ONLY)						
	366-1952-00		1	.	PUSH BUTTON:SMOKE TAN,SWEDISH						
	-----		-	.	(OPTION 4C,4F ONLY)						
	366-2000-00		1	.	PUSH BUTTON:SMOKE TAN,DIVISION/X/+/=					52833	CYXD01T116983439
	-----		-	.	(OPTION 4E ONLY)						
	260-2062-00		1	.	SW,CAPACITIVE:LOW PROFILE					52833	61-04001-001
	214-3337-00		1	.	SPRING,HLCPS:0.4 ID X 0.875 L					52833	45-00021-015
-22	366-1930-00		1	.	PUSH BUTTON:SMOKE TAN,RIGHT BRACE					52833	CYBB01T110860802
	366-1953-00		1	.	PUSH BUTTON:SMOKE TAN,SWEDISH,> OVER <						
	-----		-	.	(OPTION 4C,4F ONLY)						
	366-2009-00		1	.	PUSH BUTTON:SMOKE TAN,& BRACE/L BRACE/R					52833	CYBB01T110383439
	-----		-	.	(OPTION 4E ONLY)						
	260-2062-00		1	.	SW,CAPACITIVE:LOW PROFILE					52833	61-04001-001
	214-3337-00		1	.	SPRING,HLCPS:0.4 ID X 0.875 L					52833	45-00021-015
-23	366-1941-00		1	.	PUSH BUTTON:EARTH BROWN,RUB OUT					52833	CZWW01T1R5591101
	260-2062-00		1	.	SW,CAPACITIVE:LOW PROFILE					52833	61-04001-001
	214-3337-00		1	.	SPRING,HLCPS:0.4 ID X 0.875 L					52833	45-00021-015
-24	366-1898-00		1	.	PUSH BUTTON:EARTH BROWN,ESC					52833	CZWW02S1E3890701
	260-2062-00		1	.	SW,CAPACITIVE:LOW PROFILE					52833	61-04001-001
	214-3337-00		1	.	SPRING,HLCPS:0.4 ID X 0.875 L					52833	45-00021-015
-25	366-1897-00		1	.	PUSH BUTTON:SMOKE TAN,TILDE/BROKEN VERT					52833	CYBB01S121310802
	366-2005-00		1	.	PUSH BUTTON:SMOKE TAN,*/&						
	-----		-	.	(OPTION 4C,4F ONLY)						
	366-2007-00		1	.	PUSH BUTTON:SMOKE TAN,DIAMOND/\$/TILDE/V					52833	CYXD01S196723439
	-----		-	.	(OPTION 4E ONLY)						
	260-2062-00		1	.	SW,CAPACITIVE:LOW PROFILE					52833	61-04001-001
	214-3337-00		1	.	SPRING,HLCPS:0.4 ID X 0.875 L					52833	45-00021-015
-26	366-1929-00		1	.	PUSH BUTTON:SMOKE TAN,Q					52833	CYBB01S1Q0010101
	366-1999-00		1	.	PUSH BUTTON:SMOKE TAN,?/Q					52833	CYBB01S1563Q1402
	-----		-	.	(OPTION 4E ONLY)						
	260-2062-00		1	.	SW,CAPACITIVE:LOW PROFILE					52833	61-04001-001
	214-3337-00		1	.	SPRING,HLCPS:0.4 ID X 0.875 L					52833	45-00021-015
-27	366-1928-00		1	.	PUSH BUTTON:SMOKE TAN,W					52833	CYBB01S1W0010101
	366-1998-00		1	.	PUSH BUTTON:SMOKE TAN,OMEGA/W					52833	CYBB01S1563W1402
	-----		-	.	(OPTION 4E ONLY)						

REPLACEABLE MECHANICAL PARTS

Fig. & Index No.	Tektronix Part No.	Serial/Model No. Eff Dscont	Qty	1	2	3	4	5	Name & Description	Mfr Code	Mfr Part Number
-5	260-2062-00		1	.	SW,CAPACITIVE:LOW PROFILE					52833	61-04001-001
	214-3337-00		1	.	SPRING,HLCPS:0.4 ID X 0.875 L					52833	45-00021-015
-28	366-1927-00		1	.	PUSH BUTTON:SMOKE TAN,E					52833	CYBB01S1E0010101
	366-1997-00		1	.	PUSH BUTTON:SMOKE TAN,EPSILON/E					52833	CYBB01S1563E1402
	-----		-	.	(OPTION 4E ONLY)						
	260-2062-00		1	.	SW,CAPACITIVE:LOW PROFILE					52833	61-04001-001
	214-3337-00		1	.	SPRING,HLCPS:0.4 ID X 0.875 L					52833	45-00021-015
-29	366-1926-00		1	.	PUSH BUTTON:SMOKE TAN,R					52833	CYBB01S1R0010101
	366-2001-00		1	.	PUSH BUTTON:SMOKE TAN,R40/R					52833	CYBB01S1562R1402
	-----		-	.	(OPTION 4E ONLY)						
	260-2062-00		1	.	SW,CAPACITIVE:LOW PROFILE					52833	61-04001-001
	214-3337-00		1	.	SPRING,HLCPS:0.4 ID X 0.875 L					52833	45-00021-015
-30	366-1925-00		1	.	PUSH BUTTON:SMOKE TAN,T					52833	CYBB01S1T0010101
	366-1996-00		1	.	PUSH BUTTON:SMOKE TAN,TILDE OVER T					52833	CYBB01S1562T1402
	-----		-	.	(OPTION 4E ONLY)						
	260-2062-00		1	.	SW,CAPACITIVE:LOW PROFILE					52833	61-04001-001
	214-3337-00		1	.	SPRING,HLCPS:0.4 ID X 0.875 L					52833	45-00021-015
-31	366-1924-00		1	.	PUSH BUTTON:SMOKE TAN,Y					52833	CYBB01S1Y0010101
	366-1995-00		1	.	PUSH BUTTON:SMOKE TAN,TAKE OVER Y					52833	CYBB01S1563Y1402
	-----		-	.	(OPTION 4E ONLY)						
	260-2062-00		1	.	SW,CAPACITIVE:LOW PROFILE					52833	61-04001-001
	214-3337-00		1	.	SPRING,HLCPS:0.4 ID X 0.875 L					52833	45-00021-015
-32	366-1918-00		1	.	PUSH BUTTON:SMOKE TAN,U					52833	CYBB01S1U0010101
	366-1994-00		1	.	PUSH BUTTON:SMOKE TAN,DROP OVER U					52833	CYBB01S1563U1402
	-----		-	.	(OPTION 4E ONLY)						
	260-2062-00		1	.	SW,CAPACITIVE:LOW PROFILE					52833	61-04001-001
	214-3337-00		1	.	SPRING,HLCPS:0.4 ID X 0.875 L					52833	45-00021-015
-33	366-1919-00		1	.	PUSH BUTTON:SMOKE TAN,I					52833	CYBB01S1I0010101
	366-1993-00		1	.	PUSH BUTTON:SMOKE TAN,IOTA OVER I					52833	CYBB01S1563I1402
	-----		-	.	(OPTION 4E ONLY)						
	260-2062-00		1	.	SW,CAPACITIVE:LOW PROFILE					52833	61-04001-001
	214-3337-00		1	.	SPRING,HLCPS:0.4 ID X 0.875 L					52833	45-00021-015
-34	366-1920-00		1	.	PUSH BUTTON:SMOKE TAN,O					52833	CYBB01S1O0010101
	366-1992-00		1	.	PUSH BUTTON:SMOKE TAN,CIRCULAR OVER O					52833	CYBB01S1563O1402
	-----		-	.	(OPTION 4E ONLY)						
	260-2062-00		1	.	SW,CAPACITIVE:LOW PROFILE					52833	61-04001-001
	214-3337-00		1	.	SPRING,HLCPS:0.4 ID X 0.875 L					52833	45-00021-015
-35	366-1921-00		1	.	PUSH BUTTON:SMOKE TAN,P					52833	CYBB01S1P0010101
	366-1973-00		1	.	PUSH BUTTON:SMOKE TAN,*/P					52833	CYBB01S1562P1402
	-----		-	.	(OPTION 4E ONLY)						
	260-2062-00		1	.	SW,CAPACITIVE:LOW PROFILE					52833	61-04001-001
	214-3337-00		1	.	SPRING,HLCPS:0.4 ID X 0.875 L					52833	45-00021-015
-36	366-1896-00		1	.	PUSH BUTTON:SMOKE TAN,SM BACK SLASH					52833	CYBB01S182860802
	366-1954-00		1	.	PUSH BUTTON:SMOKE TAN,CIRCULAR OVER A						
	-----		-	.	(OPTION 4C,4F ONLY)						
	366-2008-00		1	.	PUSH BUTTON:SMOKE TAN,LEFT ARROW/RIGHT					52833	CYXD01S196743439
	-----		-	.	(OPTION 4E ONLY)						
	260-2062-00		1	.	SW,CAPACITIVE:LOW PROFILE					52833	61-04001-001
	214-3337-00		1	.	SPRING,HLCPS:0.4 ID X 0.875 L					52833	45-00021-015
-37	366-1895-00		1	.	PUSH BUTTON:EARTH BROWN,BK SPC					52833	CZWW02S1B7082105
	260-2062-00		1	.	SW,CAPACITIVE:LOW PROFILE					52833	61-04001-001
	214-3337-00		1	.	SPRING,HLCPS:0.4 ID X 0.875 L					52833	45-00021-015
-38	366-1894-00		1	.	PUSH BUTTON:EARTH BROWN,LINE FEED					52833	CZWW01S114791101
	260-2062-00		1	.	SW,CAPACITIVE:LOW PROFILE					52833	61-04001-001
	214-3337-00		1	.	SPRING,HLCPS:0.4 ID X 0.875 L					52833	45-00021-015
-39	366-1893-00		1	.	PUSH BUTTON:EARTH BROWN,TAB					52833	CZWW02R1T5990701
	260-2062-00		1	.	SW,CAPACITIVE:LOW PROFILE					52833	61-04001-001
	214-3337-00		1	.	SPRING,HLCPS:0.4 ID X 0.875 L					52833	45-00021-015
-40	366-1892-00		1	.	PUSH BUTTON:EARTH BROWN,CTRL					52833	CZWW01R1C3560701
	260-2062-00		1	.	SW,CAPACITIVE:LOW PROFILE					52833	61-04001-001
	214-3337-00		1	.	SPRING,HLCPS:0.4 ID X 0.875 L					52833	45-00021-015
-41	366-1922-00		1	.	PUSH BUTTON:SMOKE TAN,A					52833	CYBB01R1A0010101
	366-1971-00		1	.	PUSH BUTTON:SMOKE TAN,SMALL ALPHA OVER A					52833	CYBB01R1563A1402
	-----		-	.	(OPTION 4E ONLY)						
	260-2062-00		1	.	SW,CAPACITIVE:LOW PROFILE					52833	61-04001-001
	214-3337-00		1	.	SPRING,HLCPS:0.4 ID X 0.875 L					52833	45-00021-015

REPLACEABLE MECHANICAL PARTS

Fig. & Index No.	Tektronix Part No.	Serial/Model No. Eff Dscont	Qty	1	2	3	4	5	Name & Description	Mfr Code	Mfr Part Number
5-42	366-1923-00		1	.					PUSH BUTTON:SMOKE TAN,S	52833	CYBB01R1S0010101
	366-1991-00		1	.					PUSH BUTTON:SMOKE TAN,CEILING OVER S	52833	CYBB01R1563S1402
	-----		-	.					(OPTION 4E ONLY)		
	260-2062-00		1	.					SW,CAPACITIVE:LOW PROFILE	52833	61-04001-001
	214-3337-00		1	.					SPRING,HLCPS:0.4 ID X 0.875 L	52833	45-00021-015
-43	366-1914-00		1	.					PUSH BUTTON:SMOKE TAN,D	52833	CYBB01R1D0010101
	366-1990-00		1	.					PUSH BUTTON:SMOKE TAN,FLOOR OVER D	52833	CYBB01R1563D1402
	-----		-	.					(OPTION 4E ONLY)		
	260-2062-00		1	.					SW,CAPACITIVE:LOW PROFILE	52833	61-04001-001
	214-3337-00		1	.					SPRING,HLCPS:0.4 ID X 0.875 L	52833	45-00021-015
-44	366-1915-00		1	.					PUSH BUTTON:SMOKE TAN,F	52833	CYBD3R1F0010101
	366-1972-00		1	.					PUSH BUTTON:SMOKE TAN,UNDERScore/F	52833	CYBD3R1563F1402
	-----		-	.					(OPTION 4E ONLY)		
	260-2062-00		1	.					SW,CAPACITIVE:LOW PROFILE	52833	61-04001-001
	214-3337-00		1	.					SPRING,HLCPS:0.4 ID X 0.875 L	52833	45-00021-015
-45	366-1916-00		1	.					PUSH BUTTON:SMOKE TAN,G	52833	CYBB01R1G0010101
	366-1999-00		1	.					PUSH BUTTON:SMOKE TAN,?/Q	52833	CYBB01S1563Q1402
	-----		-	.					(OPTION 4E ONLY)		
	260-2062-00		1	.					SW,CAPACITIVE:LOW PROFILE	52833	61-04001-001
	214-3337-00		1	.					SPRING,HLCPS:0.4 ID X 0.875 L	52833	45-00021-015
-46	366-1917-00		1	.					PUSH BUTTON:SMOKE TAN,H	52833	CYBB01R1H0010101
	366-1988-00		1	.					PUSH BUTTON:SMOKE TAN,DELTA OVER H	52833	CYBB01R1563H1402
	-----		-	.					(OPTION 4E ONLY)		
	260-2062-00		1	.					SW,CAPACITIVE:LOW PROFILE	52833	61-04001-001
	214-3337-00		1	.					SPRING,HLCPS:0.4 ID X 0.875 L	52833	45-00021-015
-47	366-1911-00		1	.					PUSH BUTTON:SMOKE TAN,J	52833	CYBD3R1J0010101
	366-1987-00		1	.					PUSH BUTTON:SMOKE TAN,NULL OVER J	52833	CYBD3R1564J1402
	-----		-	.					(OPTION 4E ONLY)		
	260-2062-00		1	.					SW,CAPACITIVE:LOW PROFILE	52833	61-04001-001
	214-3337-00		1	.					SPRING,HLCPS:0.4 ID X 0.875 L	52833	45-00021-015
-48	366-1912-00		1	.					PUSH BUTTON:SMOKE TAN,K	52833	CYBB01R1K0010101
	366-1986-00		1	.					PUSH BUTTON:SMOKE TAN,'/K	52833	CYBB01R1K1161402
	-----		-	.					(OPTION 4E ONLY)		
	260-2062-00		1	.					SW,CAPACITIVE:LOW PROFILE	52833	61-04001-001
	214-3337-00		1	.					SPRING,HLCPS:0.4 ID X 0.875 L	52833	45-00021-015
-49	366-1913-00		1	.					PUSH BUTTON:LT GRAY,L	52833	CYBB01R1L0010101
	366-1985-00		1	.					PUSH BUTTON:SMOKE TAN,QUAD OVER L	52833	CYBB01R1563L1402
	-----		-	.					(OPTION 4E ONLY)		
	260-2062-00		1	.					SW,CAPACITIVE:LOW PROFILE	52833	61-04001-001
	214-3337-00		1	.					SPRING,HLCPS:0.4 ID X 0.875 L	52833	45-00021-015
-50	366-1891-00		1	.					PUSH BUTTON:SMOKE TAN,:OVER;	52833	CYBB01R111290802
	-----		-	.					(STANDARD AND OPTION 4A ONLY)		
	366-1984-00		1	.					PUSH BUTTON:SMOKE TAN,C/LEFT BRACKET/;/;	52833	CYXD01R117053439
	-----		-	.					(OPTION 4E ONLY)		
	366-2004-01		1	.					PUSH BUTTON:SMOKE TAN,O	52833	CYBB01R110100101
	-----		-	.					(OPTION 4F ONLY)		
	366-1956-00		1	.					PUSH BUTTON:SMOKE TAN,SWEDISH		
	-----		-	.					(OPTION 4C ONLY)		
	260-2062-00		1	.					SW,CAPACITIVE:LOW PROFILE	52833	61-04001-001
	214-3337-00		1	.					SPRING,HLCPS:0.4 ID X 0.875 L	52833	45-00021-015
-51	366-1902-00		1	.					PUSH BUTTON:SMOKE TAN," OVER '	52833	CYBB01R111300802
	366-1974-01		1	.					PUSH BUTTON:SMOKE TAN,DANISH/NORWEGIAN		
	-----		-	.					(OPTION 4F ONLY)		
	366-1955-00		1	.					PUSH BUTTON:SMOKE TAN,SWEDISH		
	-----		-	.					(OPTION 4C ONLY)		
	260-2062-00		1	.					SW,CAPACITIVE:LOW PROFILE	52833	61-04001-001
	214-3337-00		1	.					SPRING,HLCPS:0.4 ID X 0.875 L	52833	45-00021-015
-52	366-1890-00		1	.					PUSH BUTTON:EARTH BROWN,RETURN	52833	CZWW05R1R5510701
	260-2062-00		1	.					SW,CAPACITIVE:LOW PROFILE	52833	61-04001-001
	214-3337-00		1	.					SPRING,HLCPS:0.4 ID X 0.875 L	52833	45-00021-015
-53	366-1888-00		1	.					PUSH BUTTON:EARTH BRN W/LED,CAPS LOCK	52833	CZTA0125C8946002
	260-2061-00		1	.					SW,CAPACITIVE:LOW PROFILE	52833	61-04005-001
	214-3240-00		1	.					SPRING,HLCPS:0.31 ID X 0.64 L	52833	45-00021-060
-54	366-1887-00		1	.					PUSH BUTTON:EARTH BROWN,SHIFT	52833	CZWW02Q1S5770701
	260-2062-00		1	.					SW,CAPACITIVE:LOW PROFILE	52833	61-04001-001
	214-3337-00		1	.					SPRING,HLCPS:0.4 ID X 0.875 L	52833	45-00021-015

REPLACEABLE MECHANICAL PARTS

Fig. & Index No.	Tektronix Part No.	Serial/Model No. Eff Dscnt	Qty	1	2	3	4	5	Name & Description	Mfr Code	Mfr Part Number
5-55	366-1901-00		1	.					PUSH BUTTON:SMOKE TAN,Z	52833	CYBB01Q1Z0010101
	366-1983-00		1	.					PUSH BUTTON:SMOKE TAN,IMBED OVER Z	52833	CYBB01Q1563Z1402
	-----		-	.					(OPTION 4E ONLY)		
	260-2062-00		1	.					SW,CAPACITIVE:LOW PROFILE	52833	61-04001-001
	214-3337-00		1	.					SPRING,HLCPS:0.4 ID X 0.875 L	52833	45-00021-015
	-----		-	.							
-56	366-1903-00		1	.					PUSH BUTTON:SMOKE TAN,X	52833	CYBB01Q1X0010101
	366-1982-00		1	.					PUSH BUTTON:SMOKE TAN,INCLUSION OVER X	52833	CYBB01Q1563X1402
	-----		-	.					(OPTION 4E ONLY)		
	260-2062-00		1	.					SW,CAPACITIVE:LOW PROFILE	52833	61-04001-001
	214-3337-00		1	.					SPRING,HLCPS:0.4 ID X 0.875 L	52833	45-00021-015
	-----		-	.							
-57	366-1904-00		1	.					PUSH BUTTON:SMOKE TAN,C	52833	CYBB01Q1C0010101
	366-1981-00		1	.					PUSH BUTTON:SMOKE TAN,INTERSECTION OVER C	52833	CYBB01Q1563C1402
	-----		-	.					(OPTION 4E ONLY)		
	260-2062-00		1	.					SW,CAPACITIVE:LOW PROFILE	52833	61-04001-001
	214-3337-00		1	.					SPRING,HLCPS:0.4 ID X 0.875 L	52833	45-00021-015
	-----		-	.							
-58	366-1905-00		1	.					PUSH BUTTON:SMOKE TAN,V	52833	CYBB01Q1V0010101
	366-1980-00		1	.					PUSH BUTTON:SMOKE TAN,UNION OVER V	52833	CYBB01Q1563V1402
	-----		-	.					(OPTION 4E ONLY)		
	260-2062-00		1	.					SW,CAPACITIVE:LOW PROFILE	52833	61-04001-001
	214-3337-00		1	.					SPRING,HLCPS:0.4 ID X 0.875 L	52833	45-00021-015
	-----		-	.							
-59	366-1906-00		1	.					PUSH BUTTON:SMOKE TAN,B	52833	CYBB01Q1B0010101
	366-1979-00		1	.					PUSH BUTTON:SMOKE TAN,DECODE OVER B	52833	CYBB01Q1562B1402
	-----		-	.					(OPTION 4E ONLY)		
	260-2062-00		1	.					SW,CAPACITIVE:LOW PROFILE	52833	61-04001-001
	214-3337-00		1	.					SPRING,HLCPS:0.4 ID X 0.875 L	52833	45-00021-015
	-----		-	.							
-60	366-1907-00		1	.					PUSH BUTTON:SMOKE TAN,N	52833	CYBB01Q1N0010101
	366-1978-00		1	.					PUSH BUTTON:SMOKE TAN,ENCODE OVER N	52833	CYBB01Q1563N1402
	-----		-	.					(OPTION 4E ONLY)		
	260-2062-00		1	.					SW,CAPACITIVE:LOW PROFILE	52833	61-04001-001
	214-3337-00		1	.					SPRING,HLCPS:0.4 ID X 0.875 L	52833	45-00021-015
	-----		-	.							
-61	366-1908-00		1	.					PUSH BUTTON:SMOKE TAN,M	52833	CYBB01Q1M0010101
	366-1977-00		1	.					PUSH BUTTON:SMOKE TAN,RESIDUE OVER M	52833	CYBB01Q1563M1402
	-----		-	.					(OPTION 4E ONLY)		
	260-2062-00		1	.					SW,CAPACITIVE:LOW PROFILE	52833	61-04001-001
	214-3337-00		1	.					SPRING,HLCPS:0.4 ID X 0.875 L	52833	45-00021-015
	-----		-	.							
-62	366-1909-00		1	.					PUSH BUTTON:SMOKE TAN,< OVER,	52833	CYBB01Q110340802
	366-1957-00		1	.					PUSH BUTTON:SMOKE TAN,;OVER,		
	-----		-	.					(OPTION 4C,4F ONLY)		
	366-1975-00		1	.					PUSH BUTTON:SMOKE TAN,;/,/LESS THAN	52833	CYXD01Q117313440
	-----		-	.					(OPTION 4E ONLY)		
	260-2062-00		1	.					SW,CAPACITIVE:LOW PROFILE	52833	61-04001-001
-63	214-3337-00		1	.					SPRING,HLCPS:0.4 ID X 0.875 L	52833	45-00021-015
	366-1910-00		1	.					PUSH BUTTON:SMOKE TAN,> OVER ,	52833	CYBB01Q110350802
	366-1958-00		1	.					PUSH BUTTON:SMOKE TAN,SWEDISH,:OVER		
	-----		-	.					(OPTION 4C,4F ONLY)		
	366-2003-00		1	.					PUSH BUTTON:SMOKE TAN,:./>	52833	CYXD01Q117083440
	-----		-	.					(OPTION 4E ONLY)		
	260-2062-00		1	.					SW,CAPACITIVE:LOW PROFILE	52833	61-04001-001
	214-3337-00		1	.					SPRING,HLCPS:0.4 ID X 0.875 L	52833	45-00021-015
	-----		-	.							
-64	366-1886-00		1	.					PUSH BUTTON:SMOKE TAN,? OVER SLASH	52833	CYBB01Q118560802
	366-1959-00		1	.					PUSH BUTTON:SMOKE TAN,SWEDISH,-OVERDOWN		
	-----		-	.					(OPTION 4C,4F ONLY)		
	366-1976-00		1	.					PUSH BUTTON:SMOKE TAN,BACK SLASH/?	52833	CYXD01Q117093440
	-----		-	.					(OPTION 4E ONLY)		
	260-2062-00		1	.					SW,CAPACITIVE:LOW PROFILE	52833	61-04001-001
-65	214-3337-00		1	.					SPRING,HLCPS:0.4 ID X 0.875 L	52833	45-00021-015
	366-1887-00		1	.					PUSH BUTTON:EARTH BROWN,SHIFT	52833	CZWW02Q1S5770701
	260-2062-00		1	.					SW,CAPACITIVE:LOW PROFILE	52833	61-04001-001
	214-3337-00		1	.					SPRING,HLCPS:0.4 ID X 0.875 L	52833	45-00021-015
	-----		-	.							
	366-1885-00		1	.					PUSH BUTTON:EARTH BROWN,BREAK	52833	CZWW01Q1B3310701
-66	260-2062-00		1	.					SW,CAPACITIVE:LOW PROFILE	52833	61-04001-001
	214-3336-00		1	.					SPRING,HLCPS:0.31 ID X 0.64 L	52833	04500024060
	-----		-	.							
-67	366-1900-00		1	.					PUSH BUTTON:SMOKE TAN,BLANK	52833	CYCY12P110902602
	260-2062-00		1	.					SW,CAPACITIVE:LOW PROFILE	52833	61-04001-001
	214-3338-00		1	.					SPRING,HLCPS:0.4 ID X 0.875 L	52833	45-00021-015
-68	334-3804-01		1					OVERLAY,KYBD:4112/4114	80009	334-3804-01	

REPLACEABLE MECHANICAL PARTS

Fig. & Index No.	Tektronix Part No.	Serial/Model No. Eff Dscont	Qty	1 2 3 4 5	Name & Description	Mfr Code	Mfr Part Number
5-69	386-4360-01		1		PANEL,KEYBOARD:4112/4114 (ATTACHING PARTS)	80009	386-4360-01
-70	210-0457-00		12		NUT,PL,ASSEM WA:6-32 X 0.312,STL CD PL - - - * - - -	83385	OBD
-71	119-0962-00		1		LOUDSPEAKER,PM:8 OHM,3W,2.047 DIA (ATTACHING PARTS)	54473	EAS-5PH04SC
-72	211-0507-00		2		SCREW,MACHINE:6-32 X 0.312 INCH,PNH STL - - - * - - -	83385	OBD
-73	175-3219-00		1		CA ASSY,SP,ELEC:2,26 AWG,6.0 L,RIBBON	80009	175-3219-00
-74	131-0707-00		2		. CONNECTOR,TERM:22-26 AWG,BRS& CU BE GOLD	22526	47439
-75	352-0169-00		1		. HLDR,TERM CONN:2 WIRE BLACK - . (A4P3)	80009	352-0169-00
-76	407-2506-00		2		BRACKET,CMPNT:THUMBWHEEL,ALUMINUM (ATTACHING PARTS)	80009	407-2506-00
-77	211-0547-00		4		SCREW MACHING:6-32 X 0.875,TRH,STL CD PL - - - * - - -		
-78	-----		2		SWITCH,ROTARY:(SEE A9001,A9002 REPL CHASSIS PARTS) (ATTACHING PARTS)		
-79	211-0244-00		2		SCR,ASSEM WSHR:4-40 X 0.312 INCH,PNH STL - - - * - - -	78189	OBD
-80	175-3223-00		2		CA ASSY,SP,ELEC:4,26 AWG,4.0 L,RIBBON	80009	175-3223-00
-81	131-0707-00		16		. CONNECTOR,TERM:22-26 AWG,BRS& CU BE GOLD	22526	47439
-82	175-0827-00		AR		. CABLE,SP,ELEC:4,26 AWG,STRD,PVC JKT,RBN	08261	SS04267(1061)0C
-83	352-0162-00		4		. HLDR,TERM CONN:4 WIRE BLACK - . (A4P1,A4P2,THUMB WHEELS)	80009	352-0162-00
-84	175-3434-00		1		CA ASSY,SP,ELEC:20,28 AWG,72.0 L,RIBBON - (A4P4,A3A1J103)	22526	OBD
-85	195-1201-00		2		LEAD,ELECTRICAL:24 AWG,4.0 L,BRAID	80009	195-1201-00
-86	131-1216-00		1		. TERM,QIK DISC:U/W 0.25 X 0.032 TAB,BLUE	00779	42332-4
-87	210-0307-00		1		. TERMINAL,LUG:RING,INS,16-14 AWG,#8	09922	BA14E-8

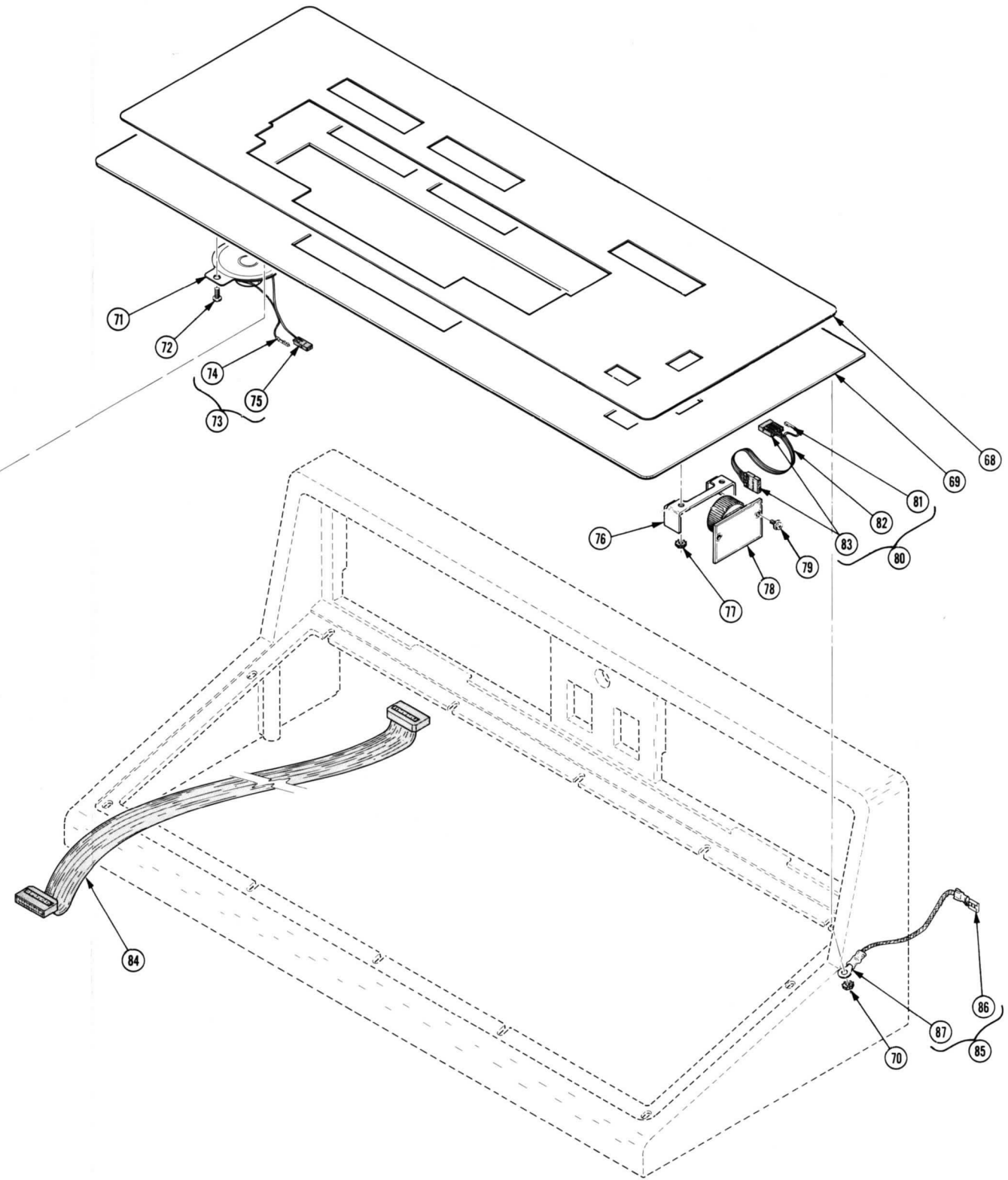
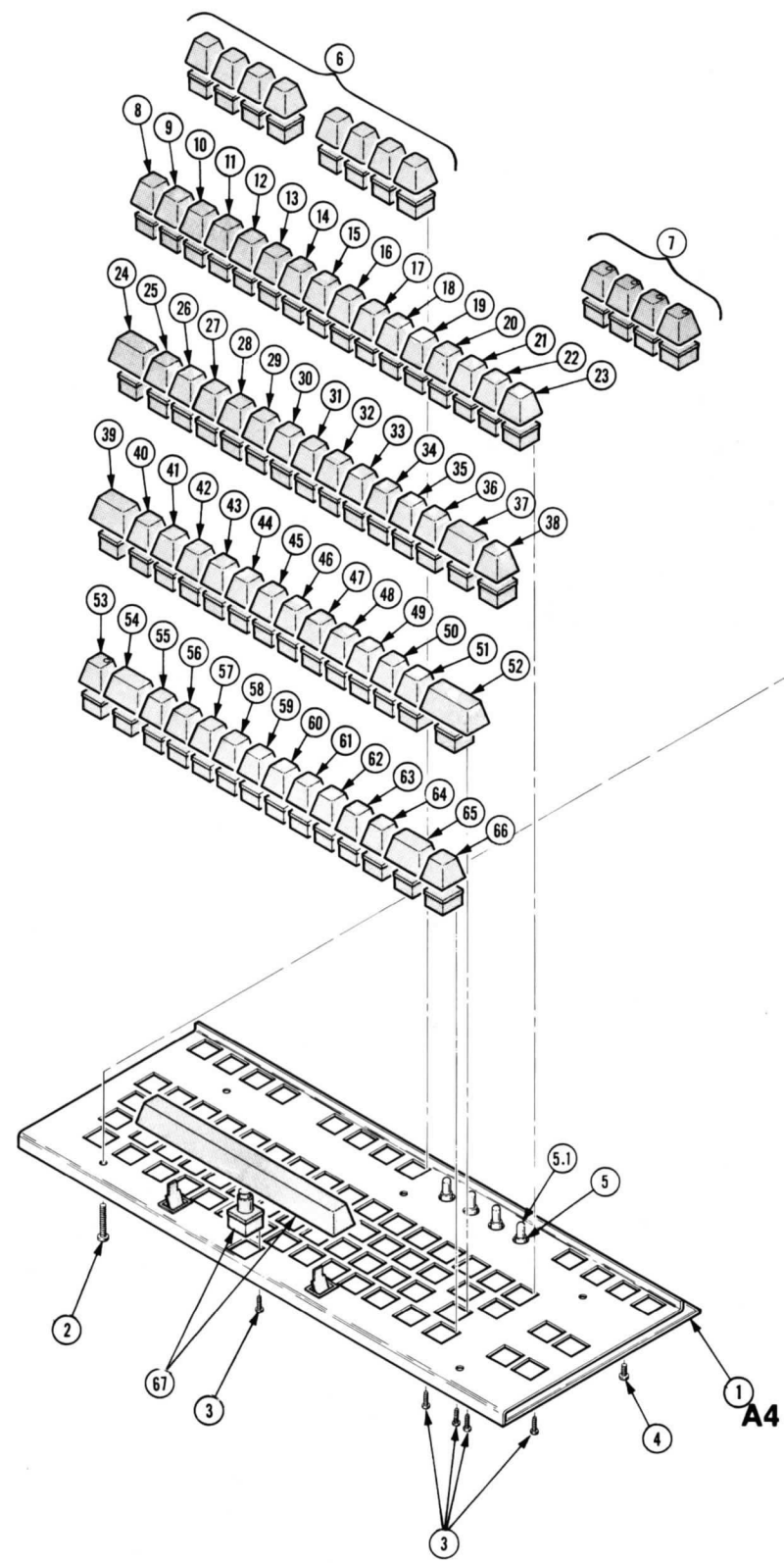
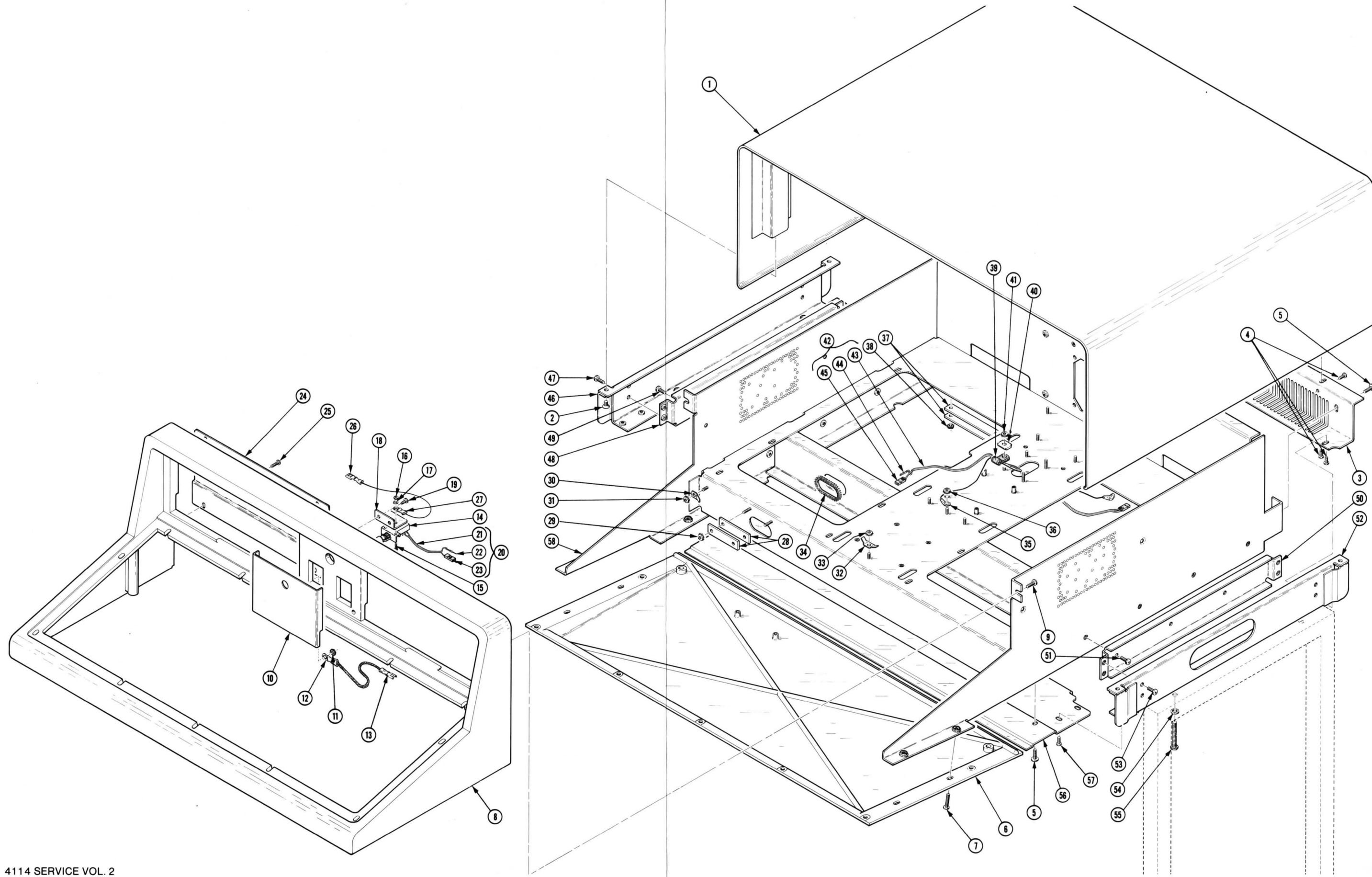

FIG. 5 KEYBOARD

FIG. 6 DRAWER ASSY, COVER



REPLACEABLE MECHANICAL PARTS

Fig. & Index No.	Tektronix Part No.	Serial/Model No. Eff Dscont	Qty	1 2 3 4 5	Name & Description	Mfr Code	Mfr Part Number
6-1	390-0795-02		1		CABINET TOP:W/STIFFENERS (ATTACHING PARTS)	80009	390-0795-02
-2	212-0560-00		4		SCREW,MACHINE:10-32 X 0.312INCH,FLH STL - - - * - - -	75497	OBD
-3	101-0053-01		1		TRIM,DECORATIVE:BACK COVER,ALUMINUM (ATTACHING PARTS)	80009	101-0053-01
-4	211-0507-00		8		SCREW,MACHINE:6-32 X 0.312 INCH,PNH STL - - - * - - -	83385	OBD
-5	212-0045-00		4		SCREW,MACHINE:8-32 X 0.500 INCH,TRH,STL	83385	OBD
-6	200-2482-01		1		COVER,BOTTOM: (ATTACHING PARTS)	80009	200-2482-01
-7	212-0033-00		13		SCREW,MACHINE:8-32 X 0.750 INCH,PNH STL - - - * - - -	83385	OBD
-8	200-2502-02		1		COV,KYBD/FLOPPY:FRONT W/BEZEL (ATTACHING PARTS)	80009	200-2502-02
-9	212-0023-00		2		SCREW,MACHINE:0-32 X 0.375,PNH,STL CD PL - - - * - - -	83385	OBD
-10	333-2726-00		1		PANEL,FRONT: (ATTACHING PARTS)	80009	333-2726-00
-11	210-0457-00		4		NUT,PL,ASSEM WA:6-32 X 0.312,STL CD PL - - - * - - -	83385	OBD
	195-1201-00		1		LEAD,ELECTRICAL:24 AWG,4.0 L,BRAID	80009	195-1201-00
-12	210-0307-00		1		. TERMINAL,LUG:RING,INS,16-14 AWG,#8	09922	BA14E-8
-13	131-1216-00		1		. TERM,QIK DISC:U/W 0.25 X 0.032 TAB,BLUE	00779	42332-4
-14	-----		1		SWITCH,PUSH:(SEE S3001 REPL CHASSIS PARTS) (ATTACHING PARTS)		
-15	211-0033-00		2		SCR,ASSEM WSHR:4-40 X 0.312 PNH,STL,CD PL	83385	OBD
-16	210-0405-00		2		NUT,PLAIN,HEX.:2-56 X 0.188 INCH,BRS	73743	12157-50
-17	210-0001-00		2		WASHER,LOCK:INTL,0.092 ID X 0.18"OD,STL - - - * - - -	78189	1202-00-00-0541C
-18	407-2571-00		1		BRACKET,ANGLE:SWITCH,ALUMINUM (ATTACHING PARTS)	80009	407-2571-00
-19	211-0504-00		2		SCREW,MACHINE:6-32 X 0.25 INCH,PNH STL - - - * - - -	83385	OBD
-20	175-3370-00		1		CA ASSY,SP,ELEC:2,26 AWG,6.0 L,RIBBON	80009	175-3370-00
-21	175-0863-00		AR		. WIRE,ELECTRICAL:2 WIRE RIBBON	08261	SS-0222-7(1061)
-22	131-0965-00		2		. CONTACT,ELEC:0.25" SQ,22-26 AWG WIRE	22526	47792
-23	204-0805-00		1		. CONN BODY,PLUG:2 CONTACTS,SINGLE ROW	0001H	OBD
-24	386-4463-00		2		PLATE,COVER:0.062 X 9.188X 4.281,AL (ATTACHING PARTS)	80009	386-4463-00
-25	213-0104-00		8		SCR,TPG,THD FOR:6-20 X 0.375 INCH,TRH STL - - - * - - -	83385	OBD
-26	131-1215-00		1		TERM,QIK DISC:U/W 0.25 X 0.032 TAB,RED	77342	42599-4
-27	210-0287-00		1		TERMINAL,LUG:# 6 RING	00779	34142
-28	343-0893-00		2		CLAMP,CABLE:2.0 L,FIBER SHEET (ATTACHING PARTS)	85471	OBD
-29	210-0457-00		2		NUT,PL,ASSEM WA:6-32 X 0.312,STL CD PL - - - * - - -	83385	OBD
-30	131-1688-00		2		TERM,QIK DISC:MALE,0.032 X 0.25 BL,45 DEG (ATTACHING PARTS)	00779	42577-4
-31	210-0457-00		2		NUT,PL,ASSEM WA:6-32 X 0.312,STL CD PL - - - * - - -	83385	OBD
-32	131-1977-00		1		TERM,QIK DISC:MALE,0.25 W TAB (ATTACHING PARTS)	00779	42577-1
-33	210-0457-00		1		NUT,PL,ASSEM WA:6-32 X 0.312,STL CD PL - - - * - - -	83385	OBD
-34	255-0334-00		1		PLASTIC CHANNEL:12.75 X 0.175X 0.155,NYL	11897	122-37-2500
-35	210-0202-00		2		TERMINAL,LUG:0.146 ID,LOCKING,BRZ TINNED (ATTACHING PARTS)	78189	2104-06-00-2520N
-36	210-0457-00		2		NUT,PL,ASSEM WA:6-32 X 0.312,STL CD PL - - - * - - -	83385	OBD
-37	343-0894-00		2		CLAMP,CABLE:3.5 L,FIBER SHEET (ATTACHING PARTS)	85471	OBD
-38	210-0457-00		2		NUT,PL,ASSEM WA:6-32 X 0.312,STL CD PL - - - * - - -	83385	OBD

REPLACEABLE MECHANICAL PARTS

Fig. & Index No.	Tektronix Part No.	Serial/Model No. Eff	Dscont	Qty	1	2	3	4	5	Name & Description	Mfr Code	Mfr Part Number
6-39	343-0001-00			1						CLAMP, LOOP: 0.15 INCH DIA, PLASTIC (ATTACHING PARTS)	95987	1-8-6B
-40	210-0863-00			1						WSHR, LOOP CLAMP: 0.187 ID U/W 0.5 W CLP, STL	95987	C191
-41	210-0457-00			1						NUT, PL, ASSEM WA: 6-32 X 0.312, STL CD PL - - - * - - -	83385	OBD
-42	175-3351-00			1						CA ASSY, SP, ELEC: 2, 26 AWG, 36.0L, RIBBON	80009	175-3351-00
-43	175-0825-00			AR						. WIRE, ELECTRICAL: 2 WIRE RIBBON	80009	175-0825-00
-44	131-0707-00			4						. CONNECTOR, TERM: 22-26 AWG, BRS& CU BE GOLD	22526	47439
-45	204-0805-00			2						. CONN BODY, PLUG: 2 CONTACTS, SINGLE ROW	000IH	OBD
-46	386-4362-01	B010100	B010249	1						SPRT, CHAS TRACK: LEFT W/ BRACKETS	80009	386-4362-01
	386-4362-03	B010250		1						SPRT, CHAS TRACK: LEFT, STEEL (ATTACHING PARTS)	80009	386-4362-03
-47	212-0023-00			4						SCREW, MACHINE: 0-32 X 0.375, PNH, STL CD PL	83385	OBD
	210-0007-00	XB010250		4						WASHER, LOCK: #8 EXT, 0.02 THK, STL CD PL - - - * - - -	78189	1108-00-00-0541C
-48	407-2572-00	B010100	B010249	1						BRACKET, SUPPORT: CHASSIS, ALUMINUM	80009	407-2572-00
	407-2572-01	B010250		1						BRACKET, SUPPORT: CHASSIS, ALUMINUM (ATTACHING PARTS)	80009	407-2572-01
-49	212-0023-00			3						SCREW, MACHINE: 0-32 X 0.375, PNH, STL CD PL	83385	OBD
	210-0007-00	XB010250		3						WASHER, LOCK: #8 EXT, 0.02 THK, STL CD PL - - - * - - -	78189	1108-00-00-0541C
-50	407-2572-00	B010100	B010249	1						BRACKET, SUPPORT: CHASSIS, ALUMINUM	80009	407-2572-00
	407-2572-01	B010250		1						BRACKET, SUPPORT: CHASSIS, ALUMINUM (ATTACHING PARTS)	80009	407-2572-01
-51	212-0023-00			4						SCREW, MACHINE: 0-32 X 0.375, PNH, STL CD PL	83385	OBD
	210-0007-00	XB010250		3						WASHER, LOCK: #8 EXT, 0.02 THK, STL CD PL - - - * - - -	78189	1108-00-00-0541C
-52	386-4361-01	B010100	B010249	1						SPRT, CHAS TRACK: RIGHT W/ BRACKETS	80009	386-4361-01
	386-4361-03	B010250		1						SPRT, CHAS TRACK: RIGHT, STEEL (ATTACHING PARTS)	80009	386-4361-03
-53	212-0023-00			4						SCREW, MACHINE: 0-32 X 0.375, PNH, STL CD PL	83385	OBD
-54	210-0852-00			4						WASHER, FLAT: 0.188 ID X 0.091 THK, STL CD	12327	OBD
	210-0007-00	XB010250		4						WASHER, LOCK: #8 EXT, 0.02 THK, STL CD PL	78189	1108-00-00-0541C
-55	212-0576-00			4						SCREW, MACHINE: 10-32 X 1.375, HEX HD, STL - - - * - - -	000EP	OBD
-56	200-2483-02	B010100	B010199	1						COVER, BOTTOM: ALUMINUM	80009	200-2483-02
	200-2483-03	B010200		1						COVER, BOTTOM: ALUMINUM (ATTACHING PARTS)	80009	200-2483-03
-57	212-0507-00			4						SCREW, MACHINE: 10-32 X 0.375 INCH, PNH STL - - - * - - -	83385	OBD
-58	441-1526-03			1						CHASSIS, TERM: FLOPPY DISC	80009	441-1526-03

REPLACEABLE MECHANICAL PARTS

Fig. & Index No.	Tektronix Part No.	Serial/Model No. Eff Dscont	Qty	1 2 3 4 5	Name & Description	Mfr Code	Mfr Part Number
7-1	200-2491-02		1		COVER, FRONT: PEDESTAL (ATTACHING PARTS)	80009	200-2491-02
-2	212-0535-00 212-0658-00	B010100 B010424 B010425	6 6		SCREW, MACHINE: 10-32 X 0.312 INCH, TRH STL SCREW, MACHINE: 10-32 X 0.375, PNH, STL - - - * - - - -	83385 12324	OBD SFSW 1 OF 6 D
-3	343-0714-00		2		RETAINER, COVER:	80009	343-0714-00
-4	210-0007-00		2		WASHER, LOCK: #8 EXT, 0.02 THK, STL CD PL	78189	1108-00-00-0541C
-5	200-2510-01		2		COVER, SIDE: PEDESTAL	80009	200-2510-01
-6	343-0714-00		6		RETAINER, COVER:	80009	343-0714-00
-7	210-0007-00		6		WASHER, LOCK: #8 EXT, 0.02 THK, STL CD PL	78189	1108-00-00-0541C
-8	101-0074-01		2		STRIP, TRIM: SIDE COVER, SLATE GRAY	80009	101-0074-01
-9	386-4372-01		1		PANEL, REAR: LOWER (ATTACHING PARTS)	80009	386-4372-01
-10	212-0535-00 212-0658-00	B010100 B010424 B010425	11 11		SCREW, MACHINE: 10-32 X 0.312 INCH, TRH STL SCREW, MACHINE: 10-32 X 0.375, PNH, STL - - - * - - - -	83385 12324	OBD SFSW 1 OF 6 D
-11	386-4373-01		1		PANEL, REAR: (ATTACHING PARTS)	80009	386-4373-01
-12	212-0535-00		3		SCREW, MACHINE: 10-32 X 0.312 INCH, TRH STL	83385	OBD
-13	212-0518-00		8		SCREW, MACHINE: 10-32 X 0.312, PNH, STL, CD PL - - - * - - - -	83385	OBD
-14	386-4371-00		3		PANEL, BLANK: (ATTACHING PARTS)	80009	386-4371-00
-15	211-0507-00		12		SCREW, MACHINE: 6-32 X 0.312 INCH, PNH STL - - - * - - - -	83385	OBD
-16	200-1532-06		2		COVER, INTFC CAV: ALUMINUM (ATTACHING PARTS)	80009	200-1532-06
-17	211-0507-00		8		SCREW, MACHINE: 6-32 X 0.312 INCH, PNH STL - - - * - - - -	83385	OBD
-18	220-0876-00		1		NUT BAR: 9.075 L X 0.25 SQ, 6-32 THD (ATTACHING PARTS)	80009	220-0876-00
-19	211-0507-00		3		SCREW, MACHINE: 6-32 X 0.312 INCH, PNH STL - - - * - - - -	83385	OBD
-20	343-0915-00		2		CLAMP, LOOP: 0.625 ID, NYLON	34785	030-0625
-21	386-4386-01		1		SUPPORT, FRAME: RIGHT, STEEL, SLATE GRAY (ATTACHING PARTS)	80009	386-4386-01
-22	212-0520-00		8		SCREW, MACHINE: 10-32 X 1.250, HEX HD, STL	83385	OBD
-23	210-0009-00		8		WASHER, LOCK: EXT, 0.193ID X 0.40" OD, STL - - - * - - - -	78189	1110-00
-24	386-4387-01		1		SUPPORT, FRAME: LEFT, STEEL, SLATE GRAY (ATTACHING PARTS)	80009	386-4387-01
-25	212-0520-00		8		SCREW, MACHINE: 10-32 X 1.250, HEX HD, STL	83385	OBD
-26	210-0009-00		8		WASHER, LOCK: EXT, 0.193ID X 0.40" OD, STL - - - * - - - -	78189	1110-00
-27	401-0486-00		4		CASTER, SWIVEL: 60MM WHEEL, BLACK, CELON (ATTACHING PARTS)	06004	61P9XP2AA
-28	212-0518-00		16		SCREW, MACHINE: 10-32 X 0.312, PNH, STL, CD PL - - - * - - - -	83385	OBD
-29	-----		2		FAN: (SEE B1003, 1004 REPL CHASSIS PARTS) (ATTACHING PARTS)		
-30	210-0457-00		8		NUT, PL, ASSEM WA: 6-32 X 0.312, STL CD PL - - - * - - - -	83385	OBD
-31	386-4462-00 -----		2		PLATE, FAN MTG: ALUMINUM (OPTION 40, 41 ONLY) (ATTACHING PARTS)	80009	386-4462-00
-32	212-0518-00		4		SCREW, MACHINE: 10-32 X 0.312, PNH, STL, CD PL - - - * - - - -	83385	OBD
-33	214-0762-00		2		GRILLE, METAL: ZINC PLATED STL (ATTACHING PARTS)	82877	20132-2
-34	211-0511-00		8		SCREW, MACHINE: 6-32 X 0.500, PNH, STL, CD PL	83385	OBD
-35	210-0457-00		8		NUT, PL, ASSEM WA: 6-32 X 0.312, STL CD PL - - - * - - - -	83385	OBD
-36	175-3221-00 ----- 175-3222-00 ----- -----		1 - 1 - -		CA ASSY, SP, ELEC: 2, 18 AWG, 11.0L, 8-N (USED WITH B1004) CA ASSY, SP, ELEC: 2, 18 AWG, 6.0 L, 8-N (USED WITH B1003) EACH CABLE INCLUDES:	80009 80009	175-3221-00 175-3222-00
-37	131-0945-00		2		. CONTACT, ELEC: CONNECTOR, BRASS TIN PL	27264	02-09-2101
-38	131-2436-00		2		. TERM, QIK DISC: 18-22 AWG, FEMALE	00779	2-520083-2

REPLACEABLE MECHANICAL PARTS

Fig. & Index No.	Tektronix Part No.	Serial/Model No. Eff	Dscont	Qty	1	2	3	4	5	Name & Description	Mfr Code	Mfr Part Number
7-39	175-2203-00			AR	.	CABLE, SP, ELEC: 2, 18 AWG, W/VINYL JACKET					80009	175-2203-00
-40	204-0827-00			1	.	CONN BODY, PLUG: 2 CONT FEMALE					27264	03-09-2022
-41	255-0334-00			1		PLASTIC CHANNEL: 12.75 X 0.175 X 0.155, NYL					11897	122-37-2500
-42	358-0661-00			6	BSHG, MACH THD: 0.5-28 X 0.393 ID, AL, 0.275 L					(ATTACHING PARTS)	80009	358-0661-00
-43	220-0859-00			6	NUT, PLAIN, HEX: 5-28 THD X 0.688 HEX, STL						80009	220-0859-00
-44	210-1039-00			6	WASHER, LOCK: INT, 0.521 ID X 0.625 INCH OD						24931	OBD
-45	200-2676-00			1	COVER, ACCESS: LINE VOLTAGE					(ATTACHING PARTS)	80009	200-2676-00
-46	212-0518-00			4	SCREW, MACHINE: 10-32 X 0.312, PNH, STL, CD PL						83385	OBD
-47	407-2538-00			1	BRKT, POWER SPLY: ALUMINUM					(ATTACHING PARTS)	80009	407-2538-00
-48	212-0518-00			4	SCREW, MACHINE: 10-32 X 0.312, PNH, STL, CD PL						83385	OBD
-49	343-0894-00			2	CLAMP, CABLE: 3.5 L, FIBER SHEET					(ATTACHING PARTS)	85471	OBD
-50	210-0457-00			2	NUT, PL, ASSEM WA: 6-32 X 0.312, STL CD PL						83385	OBD
-51	343-0893-00			2	CLAMP, CABLE: 2.0 L, FIBER SHEET					(ATTACHING PARTS)	85471	OBD
-52	210-0457-00			2	NUT, PL, ASSEM WA: 6-32 X 0.312, STL CD PL						83385	OBD
-53	214-3059-00			1	DEFLECTOR, AIR: PEDESTAL, AL					(ATTACHING PARTS)	80009	214-3059-00
-54	220-0410-00			7	NUT, EXTENDED WA: 10-32 X 0.375 INCH, STL						83385	OBD
-55	348-0704-00			2	PAD, CUSHIONING: 15.0 X 0.75 X 0.25, SIL RBR						85471	OBD
-56	407-2523-00			1	BRACKET, CMPNT: RESET SWITCH, AL					(ATTACHING PARTS)	80009	407-2523-00
-57	212-0518-00			2	SCREW, MACHINE: 10-32 X 0.312, PNH, STL, CD PL						83385	OBD
-58	343-0914-00			2	CLAMP, LOOP: 0.5 X 2.5, NYLON						34785	034-0500
-59	348-0442-00			2	GROMMET, PLASTIC: BLACK, ROUND, 0.375" ID						28520	SB-500-6
-60	175-3670-00			1	CA ASSY, SP, ELEC: 3, 26 AWG, 11.0L, RIBBON						80009	175-3670-00
-61	175-0826-00			1	. WIRE, ELECTRICAL: 3 WIRE RIBBON						80009	175-0826-00
-62	131-0707-00			3	. CONNECTOR, TERM: 22-26 AWG, BRS& CU BE GOLD						22526	47439
-63	352-0161-00			1	. HLDR, TERM CONN: 3 WIRE, BLACK						80009	352-0161-00
-64	386-4391-00			1	PANEL ASSY, PED:						80009	386-4391-00
-65	386-4370-00			1	PLATE, MOUNTING: HEAT SINK, AL						80009	386-4370-00

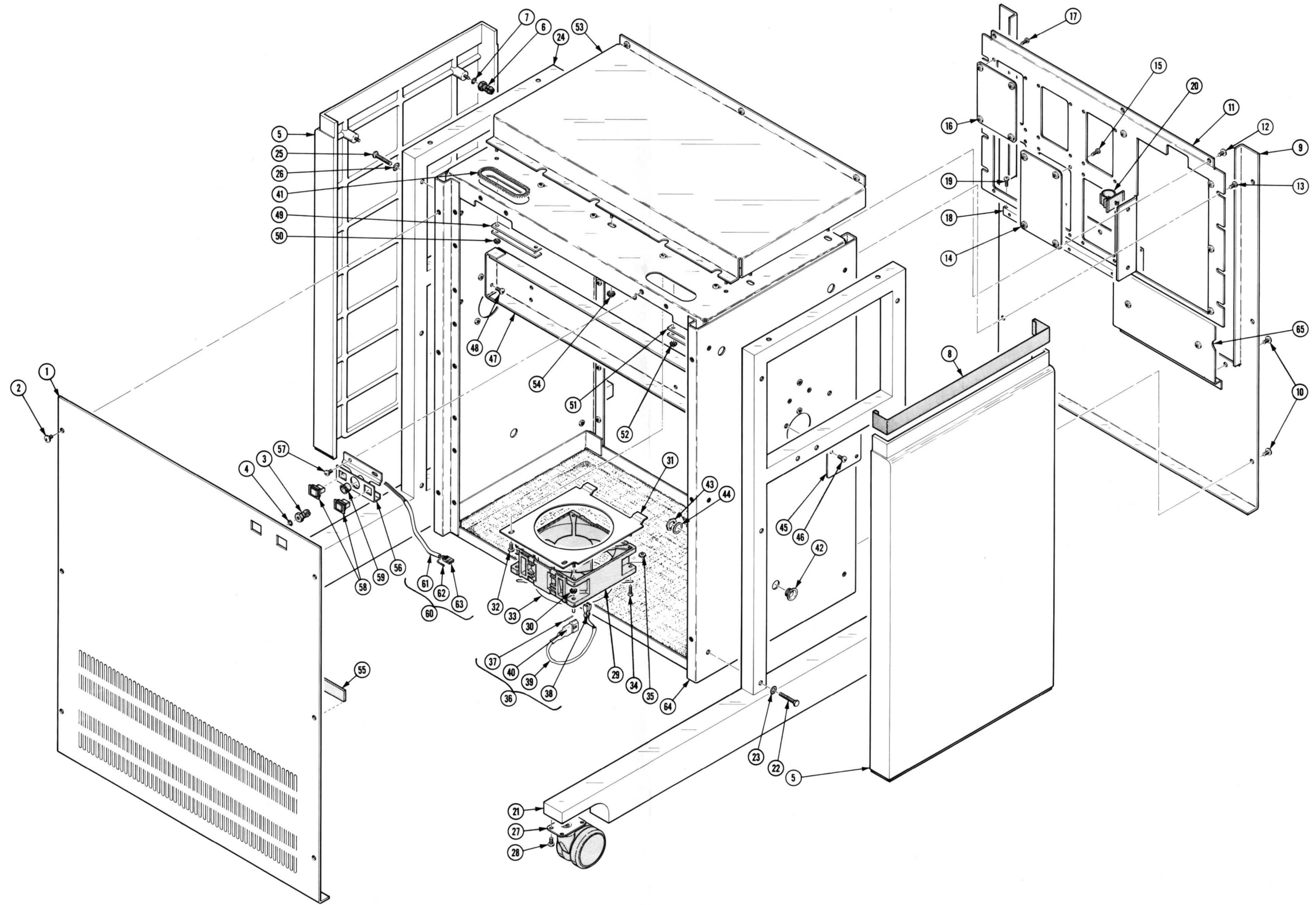
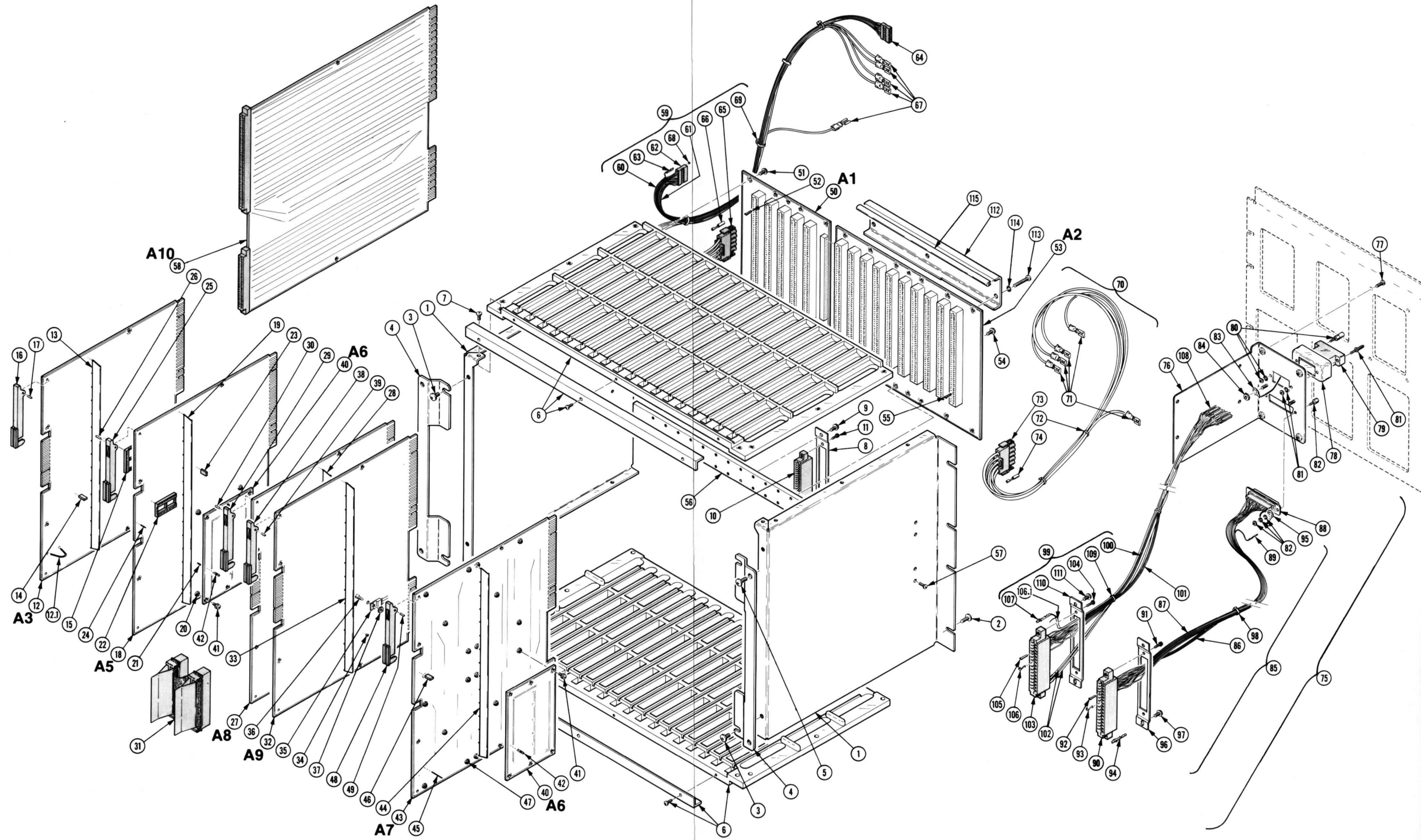

FIG. 7 PEDESTAL

FIG. 8 CARD CAGE



REPLACEABLE MECHANICAL PARTS

Fig. & Index No.	Tektronix Part No.	Serial/Model No. Eff Dscont	Qty	1 2 3 4 5	Name & Description	Mfr Code	Mfr Part Number
8-1	407-2525-00		2		BRACKET, CMPNT:CKT BD CAGE, R& L (ATTACHING PARTS)	80009	407-2525-00
-2	212-0518-00		8		SCREW, MACHINE:10-32 X 0.312, PNH, STL, CD PL	83385	OBD
-3	212-0507-00		4		SCREW, MACHINE:10-32 X 0.375 INCH, PNH STL - - - * - - -	83385	OBD
-4	407-2537-00		2		BRKT, CKT BD CAG:ALUMINUM (ATTACHING PARTS)	80009	407-2537-00
-5	212-0507-00		4		SCREW, MACHINE:10-32 X 0.375 INCH, PNH STL - - - * - - -	83385	OBD
-6	386-4410-00		2		PNL, CKT BD CAGE:UPPER & LOWER (ATTACHING PARTS)	80009	386-4410-00
-7	211-0507-00		16		SCREW, MACHINE:6-32 X 0.312 INCH, PNH STL - - - * - - -	83385	OBD
-8	386-4384-00		3		PLATE, CONN MTG:ALUMINUM (ATTACHING PARTS)	80009	386-4384-00
-9	211-0658-00		6		SCR, ASSEM WSHR:6-32 X 0.312 L, PNH, STL - - - * - - -	78189	OBD
-10	204-0877-00		2		CONN BODY, RCPT:22/44 CONTACT (ATTACHING PARTS)	00779	583891-9
-11	211-0033-00		6		SCR, ASSEM WSHR:4-40 X 0.312 PNH, STL, CD PL - - - * - - -	83385	OBD
-12	-----		1		CKT BOARD ASSY:PROCESSOR(SEE A3A1 REPL)		
-12.1	346-0032-00		1		. STRAP, RETAINING:0.075 DIA X 4.0 L, MLD RBR	98159	2859-75-4
-13	124-0388-00		1		. BUS, CONDUCTOR:CIRCUIT BOARD, 16 TAB	80009	124-0388-00
-14	131-0993-00		11		. BUS, CONDUCTOR:2 WIRE BLACK	00779	530153-2
-15	136-0751-00		8		. SKT, PL-IN ELEK:MICROCKT, 24 PIN	09922	DILB24P108
-16	105-0851-00		2		. EJECTOR, CKT BD:GRAY PLASTIC (ATTACHING PARTS)	80009	105-0851-00
-17	214-1337-00		2		. PIN, SPRING:0.10 OD X 0.25 INCH L, STL - - - * - - -	80009	214-1337-00
-18	-----		1		CKT BOARD ASSY:RAM ROM(SEE A5A1 REPL)		
-19	124-0388-00		1		. BUS, CONDUCTOR:CIRCUIT BOARD, 16 TAB	80009	124-0388-00
-20	129-0317-00		1		. POST, ELEC-MECH:4-40 X 0.187 X 0.125 INCH L	80009	129-0317-00
-21	131-0787-00		54		. CONTACT, ELEC:0.64 INCH LONG	22526	47359
-22	136-0751-00		16		. SKT, PL-IN ELEK:MICROCKT, 24 PIN	09922	DILB24P108
-23	131-0993-00		16		. BUS, CONDUCTOR:2 WIRE BLACK	00779	530153-2
-24	131-0608-00		4		. TERMINAL, PIN:0.365 L X 0.025 PH BRZ GOLD	22526	47357
-25	105-0851-00		2		. EJECTOR, CKT BD:GRAY PLASTIC (ATTACHING PARTS)	80009	105-0851-00
-26	214-1337-00		2		. PIN, SPRING:0.10 OD X 0.25 INCH L, STL - - - * - - -	80009	214-1337-00
-27	-----		1		CKT BOARD ASSY:DISPLAY CONTROLLER(SEE A8 REPL)		
-28	124-0388-00		1		. BUS, CONDUCTOR:CIRCUIT BOARD, 16 TAB	80009	124-0388-00
-29	105-0851-00		2		. EJECTOR, CKT BD:GRAY PLASTIC (ATTACHING PARTS)	80009	105-0851-00
-30	214-1337-00		2		. PIN, SPRING:0.10 OD X 0.25 INCH L, STL - - - * - - -	80009	214-1337-00
-31	175-3266-00		1		CA ASSY, SP, ELEC:50, 28 AWG, 2.0L, RIBBON	00011	175-3266-00
-32	-----		1		CKT BOARD ASSY:VECTOR GENERATOR(SEE A9 REPL)		
-33	124-0388-00		1		. BUS, CONDUCTOR:CIRCUIT BOARD, 16 TAB	80009	124-0388-00
-34	136-0333-00		4		. SOCKET, PIN TERM:0.138 INCH LONG	00779	1-331677-4
-35	-----		1		. TRANSISTOR:(SEE A9Q626 REPL) (ATTACHING PARTS)		
-36	211-0008-00		1		. SCREW, MACHINE:4-40 X 0.250, PNH, STL, CD PL	83385	OBD
-37	210-0586-00		1		. NUT, PL, ASSEM WA:4-40 X 0.25, STL CD PL - - - * - - -	83385	OBD
-38	105-0851-00		1		. EJECTOR, CKT BD:GRAY PLASTIC (ATTACHING PARTS)	80009	105-0851-00
-39	214-1337-00		2		. PIN, SPRING:0.10 OD X 0.25 INCH L, STL - - - * - - -	80009	214-1337-00
-40	-----		1		CKT BOARD ASSY:RAM ARRAY(SEE A6 REPL) (ATTACHING PARTS)		
-41	211-0244-00		4		SCR, ASSEM WSHR:4-40 X 0.312 INCH, PNH STL - - - * - - -	78189	OBD

REPLACEABLE MECHANICAL PARTS

Fig. & Index No.	Tektronix Part No.	Serial/Model No. Eff	Discont	Qty	1	2	3	4	5	Name & Description	Mfr Code	Mfr Part Number
8-	-----									- RAM ARRAY BOARD INCLUDES:		
-42	136-0263-04			54						. SOCKET,PIN TERM:FOR 0.025 INCH SQUARE PIN	22526	75377-001
-43	-----			1						CKT BOARD ASSY:RAM CONTROLLER(SEE A7 REPL)		
-44	124-0388-00			1						. BUS,CONDUCTOR:CIRCUIT BOARD,16 TAB	80009	124-0388-00
-45	131-0787-00			216						. CONTACT,ELEC:0.64 INCH LONG	22526	47359
-46	131-0993-00			1						. BUS,CONDUCTOR:2 WIRE BLACK	00779	530153-2
-47	129-0317-00			20						. POST,ELEC-MECH:4-40 X 0.187 X 0.125 INCH L	80009	129-0317-00
-48	105-0851-00			2						. EJECTOR,CKT BD:GRAY PLASTIC (ATTACHING PARTS)	80009	105-0851-00
-49	214-1337-00			2						. PIN,SPRING:0.10 OD X 0.25 INCH L,STL - - - * - - -	80009	214-1337-00
-50	-----			1						CKT BOARD ASSY:MOTHER(SEE A1 REPL) (ATTACHING PARTS)		
-51	211-0658-00			8						SCR,ASSEM WSHR:6-32 X 0.312 L,PNH,STL - - - * - - -	78189	OBD
-52	214-3114-00			10						- MOTHER BOARD INCLUDES: . KEY,CONN PLZN:CIRCUIT BD CONN	00779	530687-1
-53	-----			1						CKT BOARD ASSY:MOTHER BD EXTENDER(SEE A2 REPL) (ATTACHING PARTS)		
-54	211-0658-00			12						SCR,ASSEM WSHR:6-32 X 0.312 L,PNH,STL - - - * - - -	78189	OBD
-55	214-3114-00			20						- MOTHER BOARD EXTENDER INCLUDES: . KEY,CONN PLZN:CIRCUIT BD CONN	00779	530687-1
-56	386-4385-00			1						SUPPORT,CKT BD:ALUMINUM (ATTACHING PARTS)	80009	386-4385-00
-57	212-0518-00			4						SCREW,MACHINE:10-32 X 0.312,PNH,STL,CD PL - - - * - - -	83385	OBD
-58	-----			1						CKT BOARD ASSY:LOGIC EXTENDER(SEE A10 REPL)		
-59	179-2758-00			1						WIRING HARNESS:MOTHER BOARD	29598	OBD
-60	175-3552-00			AR						. CA ASSY,SP,ELEC:7,22 AWG,26.0L,RIBBON	80009	175-3552-00
-61	175-3553-00			AR						. CA ASSY,SP,ELEC:8,22 AWG,26.0L,RIBBON	80009	175-3553-00
-62	352-0484-01			1						. HLDR,TERM CONN:16 WIRE,DBL ROW,BLACK	22526	65043-124
-63	131-0621-00			15						. CONNECTOR,TERM:22-26 AWG,BRS& CU BE GOLD	22526	46231
-64	352-0484-00			1						. HLDR,TERM CONN:16 WIRE,DBL ROW,BLACK	22526	65043-124
-65	204-0891-00			1						. CONN BODY,PLUG:5 MALE CONTACTS	00779	350809-1
-66	131-2386-00			5						. CONTACT,ELEC:CONN,FEMALE,PH	00779	640310-3
-67	131-1565-00			5						. TERMINAL BOARD:ACCOM 5 TERM,POLYCARBONATE	80009	131-1565-00
-68	134-0153-00			1						. KEY,PLZN CONN:MINI LATCH HSG	80009	134-0153-00
-69	343-0549-00			5						. STRAP,TIEDOWN:0.091 W X 3.62 INCH LONG	59730	TY100
-70	198-4330-00			1						WIRE SET,ELEC:	80009	198-4330-00
-71	131-1563-00			5						. TERM,QIK DISC.:FEMALE ACCOM 0.25 X 0.037	00779	61198-1
-72	343-0549-00			2						. STRAP,TIEDOWN:0.091 W X 3.62 INCH LONG	59730	TY100
-73	204-0891-00			1						. CONN BODY,PLUG:5 MALE CONTACTS	00779	350809-1
-74	131-2386-00			5						. CONTACT,ELEC:CONN,FEMALE,PH	00779	640310-3
-75	198-4344-00			1						WIRE SET,ELEC:	80009	198-4344-00
-76	386-4554-00			1						. PANEL,CMPNT MTG:CONNECTOR & CABLE,AL (ATTACHING PARTS)	80009	386-4554-00
-77	211-0507-00			4						SCREW,MACHINE:6-32 X 0.312 INCH,PNH STL - - - * - - -	83385	OBD
-78	200-2446-00			1						(198-4344-00 INCLUDES) . COVER,CONNECTOR:26 PIN,SET,ZINC PLATED	00779	201349-2
-79	204-0862-00			1						. CONN BODY,RCPT:26 CONT,FEMALE (ATTACHING PARTS)	00779	200512-2
-80	213-0444-00			1						. JACKSCREW:CONN,FIXED,FEM,SST	00779	213-0444-00
-81	213-0488-00			1						. JACKSCREW:FXD MALE,U/W M SERIES CONN - - - * - - -	00779	200874-1
-82	131-0890-00			2						. LOCK,CONNECTOR:4-40 X 0.312 L	71468	D 20418-2
-83	210-0202-00			1						. TERMINAL,LUG:0.146 ID,LOCKING,BRZ TINNED (ATTACHING PARTS)	78189	2104-06-00-2520N
-84	210-0457-00			1						NUT,PL,ASSEM WA:6-32 X 0.312,STL CD PL - - - * - - -	83385	OBD

REPLACEABLE MECHANICAL PARTS

Fig. & Index No.	Tektronix Part No.	Serial/Model No. Eff Dscont	Qty	1	2	3	4	5	Name & Description	Mfr Code	Mfr Part Number
	-----		-						(198-4344-00 INCLUDES:)		
8-85	175-3186-00		1						. CA ASSY, SP, ELEC:14, 26 AWG, 1, 22 AWG, 24.0 L	80009	175-3186-00
-86	175-0827-00		AR						. . CABLE, SP, ELEC:4, 26 AWG, STRD, PVC JKT, RBN	08261	SS04267(1061)OC
-87	175-0833-00		AR						. . WIRE, ELECTRICAL:10 WIRE RIBBON	08261	SS-1026-7
-88	131-1316-00		1						. . CONNECTOR BODY, :25 MALE-CONT POSITIONS	00779	208076-1
-89	131-1279-00		14						. . CONTACT, ELEC:MALE, 28-24 AWG WIRE, 0.040 DIA	00779	205310-4
	131-1450-00		1						. . CONTACT, ELEC:MALE, 24-30 AWG WIRE, 0.040 DIA	00779	205202-6
-90	204-0877-00		1						. . CONN BODY, RCPT:22/44 CONTACT	00779	583891-9
									(ATTACHING PARTS)		
-91	211-0033-00		2						. . SCR, ASSEM WSHR:4-40 X 0.312 PNH, STL, CD PL	83385	OBD
									-----*		
-92	214-3114-00		2						. . KEY, CONN PLZN:CIRCUIT BD CONN	00779	530687-1
-93	214-3082-00		4						. . SPRING, RTNG:CU BE, GOLD FASH OVER NP	00779	583691-3
-94	131-2161-01		14						. . TERM, QIK DISC:24-28 AWG, PHOSPHOR	00779	583616-2
-95	210-0202-00		1						. . TERMINAL, LUG:0.146 ID, LOCKING, BRZ TINNED	78189	2104-06-00-2520N
-96	386-4384-00		1						PLATE, CONN MTG:ALUMINUM	80009	386-4384-00
									(ATTACHING PARTS)		
-97	211-0658-00		2						SCR, ASSEM WSHR:6-32 X 0.312 L, PNH, STL	78189	OBD
									-----*		
	-----		-						(198-4344-00 INCLUDES:)		
	-----		-						. (175-3186-00 INCLUDES:)		
-98	343-0549-00		1						. . STRAP, TIEDOWN:0.091 W X 3.62 INCH LONG	59730	TY100
-99	198-4311-00		1						. WIRE SET, ELEC:	80009	198-4311-00
-100	175-0833-00		AR						. . WIRE, ELECTRICAL:10 WIRE RIBBON	08261	SS-1026-7
-101	175-0826-00		AR						. . WIRE, ELECTRICAL:3 WIRE RIBBON	80009	175-0826-00
-102	175-0072-00		1						. . CABLE, RF:2 CONDUCTOR	80009	175-0072-00
-103	204-0877-00		1						. . CONN BODY, RCPT:22/44 CONTACT	00779	583891-9
									(ATTACHING PARTS)		
-104	211-0033-00		2						. . SCR, ASSEM WSHR:4-40 X 0.312 PNH, STL, CD PL	83385	OBD
									-----*		
-105	214-3114-00		2						. . KEY, CONN PLZN:CIRCUIT BD CONN	00779	530687-1
-106	214-3082-00		2						. . SPRING, RTNG:CU BE, GOLD FASH OVER NP	00779	583691-3
106.1	175-1020-09		AR						. . CABLE, RF:50 OHM COAX, W/WHT VINYL JKT	80009	175-1020-09
-107	131-2161-01		18						. . TERM, QIK DISC:24-28 AWG, PHOSPHOR	00779	583616-2
	131-2544-00		3						. . CONNECTOR, TERM:18-22 AWG, PH BRZ, GOLD PL	00779	583649-3
-108	131-1039-00		3						. . CONNECTOR, TERM:20-22 AWG, CU BE GOLD PL	00779	66104-6
	131-2396-00		18						. . CONTACT, ELEC:CONN, FEMALE SST GOLD PL	00779	66479-1
-109	343-0549-00		3						. . STRAP, TIEDOWN:0.091 W X 3.62 INCH LONG	59730	TY100
-110	386-4384-00		1						PLATE, CONN MTG:ALUMINUM	80009	386-4384-00
									(ATTACHING PARTS)		
-111	211-0658-00		2						SCR, ASSEM WSHR:6-32 X 0.312 L, PNH, STL	78189	OBD
									-----*		
-112	386-4822-00	XB010170	1						STIF, CKT BD CG:ALUMINUM	80009	386-4822-00
									(ATTACHING PARTS)		
-113	211-0514-00	XB010170	3						SCREW, MACHINE:6-32 X 0.750 INCH, PNH STL	83385	OBD
-114	210-0005-00	XB010170	3						WASHER, LOCK:#6 EXT, 0.02 THK, STL	78189	1106-00
									-----*		
-115	255-0334-00	XB010170	AR						PLASTIC CHANNEL:12.75 X 0.175X 0.155, NYL	11897	122-37-2500

REPLACEABLE MECHANICAL PARTS

Fig. & Index No.	Tektronix Part No.	Serial/Model No. Eff	Dscont	Qty	1	2	3	4	5	Name & Description	Mfr Code	Mfr Part Number
9-	-----			1						POWER SUPPLY ASSY:(SEE A17 REPL)		
-1	386-4363-00			1						. SPRT,POWER SPLY:FRONT,AL (ATTACHING PARTS)	80009	386-4363-00
-2	211-0507-00			6						. SCREW,MACHINE:6-32 X 0.312 INCH,PNH STL	83385	OBD
-3	211-0504-00			6						. SCREW,MACHINE:6-32 X 0.25 INCH,PNH STL -----*	83385	OBD
-4	200-2481-00			1						. COVER,PWR SPLY:LEFT,AL (ATTACHING PARTS)	80009	200-2481-00
-5	211-0511-00			1						. SCREW,MACHINE:6-32 X 0.500,PNH,STL,CD PL -----*	83385	OBD
-6	214-2853-00			1						. BOLT,U:6-32 X 3.4 X 2.69,BRASS	02114	70 U BOLT
-7	210-0457-00			1						. NUT,PL,ASSEM WA:6-32 X 0.312,STL CD PL	83385	OBD
-8	-----			1						. CKT BOARD ASSY:REGUALTOR(SEE A17A2 REPL) (ATTACHING PARTS)		
-9	211-0244-00			8						. SCR,ASSEM WSHR:4-40 X 0.312 INCH,PNH STL -----*	78189	OBD
	-----			-						REGULATOR BOARD ASSY INCLUDES:		
-10	-----			1						. . TRANSFORMER(SEE A17A2T190 REPL)		
-11	-----			-						. . COIL:(SEE A17A2L291 REPL) (ATTACHING PARTS)		
-12	211-0003-00			1						. . SCREW,MACHINE:2-56 X 0.875 INCH,PNH,STL	83385	OBD
-13	210-0053-00			1						. . WASHER,LOCK:INTL,0.092 ID X 0.175"OD,STL	83385	OBD
-14	210-0405-00			1						. . NUT,PLAIN,HEX.:2-56 X 0.188 INCH,BRS -----*	73743	12157-50
-15	-----			1						. . COIL:(SEE A17A2L361 REPL) (ATTACHING PARTS)		
-16	343-0769-00			1						. . CLAMP,POT CORE: -----*	000IJ	FP 36/ZZ-66
-17	-----			1						. TRANSISTOR:(SEE A17Q795 REPL) (ATTACHING PARTS)		
-18	211-0097-00			1						. SCREW,MACHINE:4-40 X 0.312 INCH,PNH STL	83385	OBD
-19	210-1291-00			1						. WASHER,SHLDR:0.118 ID X 0.1 THK,PLSTC	80009	210-1291-00
-20	342-0311-00			1						. INSULATOR,PLATE:TRANSISTOR,MICA	01295	64-21-023-212
	342-0328-00			1						. INSULATOR,PLATE:XSTR,ALUMINUM -----*	80009	342-0328-00
-21	-----			1						. TRANSISTOR:(SEE A17Q761 REPL) (ATTACHING PARTS)		
-22	211-0097-00			1						. SCREW,MACHINE:4-40 X 0.312 INCH,PNH STL	83385	OBD
-23	210-1291-00			1						. WASHER,SHLDR:0.118 ID X 0.1 THK,PLSTC	80009	210-1291-00
-24	342-0202-00			1						. INSULATOR,PLATE:TRANSISTOR	01295	10-21-023-106
	342-0328-00			1						. INSULATOR,PLATE:XSTR,ALUMINUM -----*	80009	342-0328-00
-25	-----			2						. TRANSISTOR:(SEE A17Q751,A17Q785 REPL) (ATTACHING PARTS)		
-26	211-0097-00			2						. SCREW,MACHINE:4-40 X 0.312 INCH,PNH STL	83385	OBD
-27	210-1291-00			2						. WASHER,SHLDR:0.118 ID X 0.1 THK,PLSTC	80009	210-1291-00
-28	342-0202-00			2						. INSULATOR,PLATE:TRANSISTOR	01295	10-21-023-106
	342-0328-00			2						. INSULATOR,PLATE:XSTR,ALUMINUM -----*	80009	342-0328-00
-29	-----			2						. TRANSISTOR:(SEE A17Q741,A17Q771 REPL) (ATTACHING PARTS)		
-30	211-0097-00			2						. SCREW,MACHINE:4-40 X 0.312 INCH,PNH STL	83385	OBD
-31	210-1291-00			2						. WASHER,SHLDR:0.118 ID X 0.1 THK,PLSTC	80009	210-1291-00
-32	342-0202-00			2						. INSULATOR,PLATE:TRANSISTOR	01295	10-21-023-106
	342-0328-00			2						. INSULATOR,PLATE:XSTR,ALUMINUM -----*	80009	342-0328-00
-33	407-2511-00			1						. BRACKET,SUPPORT:POWER SUPPLY,REGULATOR (ATTACHING PARTS)	80009	407-2511-00
-34	211-0511-00			4						. SCREW,MACHINE:6-32 X 0.500,PNH,STL,CD PL -----*	83385	OBD
-35	210-0457-00			3						. NUT,PL,ASSEM WA:6-32 X 0.312,STL CD PL	83385	OBD
-36	333-2751-00	B010100	B010319	1						. PANEL,REAR:	80009	333-2751-00
	333-2751-01	B010320	B010649	1						. PANEL,REAR:	80009	333-2751-01
	333-2751-02	B010650		1						. PANEL,REAR:	80009	333-2751-02
-37	-----			1						. CONN RECPT:PWR FEMALE(SEE A17J3002 REPL) (ATTACHING PARTS)		
-38	211-0012-00			2						. SCREW,MACHINE:4-40 X 0.375,PNH STL CD PL -----*	83385	OBD

REPLACEABLE MECHANICAL PARTS

Fig. & Index No.	Tektronix Part No.	Serial/Model No. Eff Dscont	Qty	1	2	3	4	5	Name & Description	Mfr Code	Mfr Part Number
9-39	-----	-----	1	.	CONN RECPT:PWR MALE(SEE A17J3001 REPL)				(ATTACHING PARTS)		
-40	211-0012-00		2	.	SCREW,MACHINE:4-40 X 0.375,PNH STL CD PL					83385	OBD
-41	195-0954-00		2	.	LEAD,ELECTRICAL:18 AWG,5.0 L,5-4					80009	195-0954-00
-42	210-0202-00		2	.	TERMINAL,LUG:0.146 ID,LOCKING,BRZ TINNED					78189	2104-06-00-2520N
-43	204-0832-00		1	.	BODY,FUSEHOLDER:3AG,5 X 20MM FUSES					S3629	031.1673(MDLFEU)
-44	210-1039-00		1	.	WASHER,LOCK:INT,0.521 ID X 0.625 INCH OD					24931	OBD
-45	200-2264-00		1	.	CAP.,FUSEHOLDER:3AG FUSES					S3629	FEK 031 1666
-46	-----	-----	1	.	COIL POT CORE:(SEE A17L1001 REPL)				(ATTACHING PARTS)		
-47	343-0871-00		1	.	CLAMP,MOUNTING:POT COIL,AL					80009	343-0871-00
-48	211-0530-00		1	.	SCREW,MACHINE:6-32 X 1.75 INCH,PNH STL					83385	OBD
-49	-----	-----	1	.	LINE FILTER:(SEE A17FL1001 REPL)				(ATTACHING PARTS)		
-50	210-0586-00		2	.	NUT,PL,ASSEM WA:4-40 X 0.25,STL CD PL					83385	OBD
-51	366-1522-00		1	.	KNOB:LINE VOLTAGE INDICATOR				(ATTACHING PARTS)	80009	366-1522-00
-52	211-0507-00		1	.	SCREW,MACHINE:6-32 X 0.312 INCH,PNH STL					83385	OBD
-53	200-2501-00		1	.	COVER,DIODE:ALUMINUM				(ATTACHING PARTS)	80009	200-2501-00
-54	211-0513-00		2	.	SCREW,MACHINE:6-32 X 0.625 INCH,PNH STL					83385	OBD
-55	-----	-----	2	.	SEMICONV DEVICE:(SEE A17CR1001,A17CR1004 REPL)				(ATTACHING PARTS)		
-56	210-0224-00		2	.	TERMINAL,LUG:0.20 ID X 0.344 OD,SE,BRS					86928	A373-148-1
-57	210-0909-00		4	.	WASHER,NONMETAL:0.196 ID X 0.625" OD,MICA					83309	OBD
-58	210-0910-00		2	.	WASHER,NONMETAL:0.188 ID X 0.313" OD,TEFLON					02107	OBD
-59	210-1266-00		2	.	WASHER,FLAT:0.193 ID X 0.475 OD X 0.0075"					86928	5702-79-75
-60	210-0410-00		2	.	NUT,PLAIN,HEX.:10-32 X 0.312 INCH,BRS					73743	2X20003-402
-61	-----	-----	2	.	SEMICONV DEVICE:(SEE A17CR1002,A17CR1003 REPL)				(ATTACHING PARTS)		
-62	210-0333-00		2	.	TERMINAL LUG:0.255 ID,BRASS,TIN PLATED					86928	5411-38
-63	210-1286-00		4	.	WASHER,FLAT:0.25 ID X 0.002 THK,MICA					86928	5624-72-2
-64	210-1115-00		2	.	WASHER,FLAT:0.27 ID X 0.062 THK,0.37 OD					86445	OBD
-65	210-0853-00		2	.	WASHER,FLAT:0.25 ID X 0.50 OD					86044	OBD
-66	210-0455-00		2	.	NUT,PLAIN,HEX.:0.25-28 X 0.375 INCH,BRASS					73743	3089-402
-67	210-0285-00		2	.	TERMINAL,LUG:				(ATTACHING PARTS)	00779	321051
-68	211-0507-00		2	.	SCREW,MACHINE:6-32 X 0.312 INCH,PNH STL					83385	OBD
-69	210-0457-00		2	.	NUT,PL,ASSEM WA:6-32 X 0.312,STL CD PL					83385	OBD
-70	407-2510-00		1	.	BRACKET,SUPPORT:POWER SUPPLY,INVERTER,AL				(ATTACHING PARTS)	80009	407-2510-00
-71	211-0511-00		3	.	SCREW,MACHINE:6-32 X 0.500,PNH,STL,CD PL					83385	OBD
-72	-----	-----	1	.	CKT BOARD ASSY:INVERTER(SEE A17A1 REPL)				(ATTACHING PARTS)		
-73	211-0244-00		9	.	SCR,ASSEM WSHR:4-40 X 0.312 INCH,PNH STL					78189	OBD
-74	-----	-----	1	.	INVERTER BOARD INCLUDES:						
-74	-----	-----	1	.	TRANSISTOR:(SEE A17A1Q205 REPL)				(ATTACHING PARTS)		
-75	211-0014-00		1	.	SCREW,MACHINE:4-40 X 0.50 INCH,PNH STL					83385	OBD
-76	214-2957-00		1	.	HEAT SINK,XSTR:TO-220,AL					80009	214-2957-00
-77	166-0093-00		1	.	SPACER,SLEEVE:0.196 ID X 0.188" LONG,AL					80009	166-0093-00
-78	210-0586-00		1	.	NUT,PL,ASSEM WA:4-40 X 0.25,STL CD PL					83385	OBD
-79	334-2359-00		1	.	MARKER,IDENT:WARNING					80009	334-2359-00
-80	131-0993-00		1	.	BUS,CONDUCTOR:2 WIRE BLACK					00779	530153-2

REPLACEABLE MECHANICAL PARTS

Fig. & Index No.	Tektronix Part No.	Serial/Model No. Eff	Dscont	Qty	1	2	3	4	5	Name & Description	Mfr Code	Mfr Part Number
9-81	198-4571-00			1	WIRE SET, ELEC:	80009	198-4571-00
-81.1	131-0621-00			6	CONNECTOR, TERM: 22-26 AWG, BRS& CU BE GOLD	22526	46231
-81.2	352-0206-00			1	HLDR, TERM CONN: 10 WIRE BLACK	80009	352-0206-00
	-----			-	(A17A1P62)		
-82	-----			2	TRANSISTOR: (SEE A17Q710, A17Q720 REPL) (ATTACHING PARTS)		
-83	211-0513-00			2	SCREW, MACHINE: 6-32 X 0.625 INCH, PNH STL	83385	OBD
-84	342-0449-01			1	INSULATOR, PLATE: TRANSISTOR, ALUMINA, PRINTED	80009	342-0449-01
-85	342-0458-00			1	INSULATOR, PLATE: TRANSISTOR, MICA	08530	OBD
-86	200-2269-00			1	COVER, XSTR:	80009	200-2269-00
					-	-	-	-	-	* - - -		
-87	195-1528-00			1	LEAD, ELECTRICAL: 26 AWG, 2.5 L, 9-N	80009	195-1528-00
	-----			-	(A17Q710, A17Q720)		
-88	131-0707-00			1	CONNECTOR, TERM: 22-26 AWG, BRS& CU BE GOLD	22526	47439
-89	352-0171-00			1	HLDR, TERM CONN: 1 WIRE BLACK	80009	352-0171-00
	-----			-	(A17A1P66)		
-90	343-0937-00			1	RETAINER, CAP: POLYURETHANE	80009	343-0937-00
-91	343-0937-01			1	RETAINER, CAP: POLYURETHANE	80009	343-0937-01
-92	343-0549-00			1	STRAP, TIEDOWN: 0.091 W X 3.62 INCH LONG	59730	TY100
-93	200-2480-00			1	COVER, PWR SPLY: RIGHT, AL	80009	200-2480-00
					(ATTACHING PARTS)		
-94	211-0511-00			3	SCREW, MACHINE: 6-32 X 0.500, PNH, STL, CD PL	83385	OBD
					-	-	-	-	-	* - - -		
-95	214-3037-00	B010100	B010549	1	HEAT SINK, ELEC: POWER SUPPLY	80009	214-3037-00
	214-3037-01	B010550		1	HEAT SINK, ELEC: POWER SUPPLY	80009	214-3037-01
					(ATTACHING PARTS)		
-96	212-0004-00			6	SCREW, MACHINE: 8-32 X 0.312 INCH, PNH STL	83385	OBD
-97	211-0511-00			2	SCREW, MACHINE: 6-32 X 0.500, PNH, STL, CD PL	83385	OBD
					-	-	-	-	-	* - - -		
-98	175-5132-00			1	CA ASSY, SP, ELEC: 10, 26 AWG, 6.5L, RIBBON	80009	175-5132-00
-99	175-0833-00			AR	WIRE, ELECTRICAL: 10 WIRE RIBBON	08261	SS-1026-7
-100	131-0707-00			20	CONNECTOR, TERM: 22-26 AWG, BRS& CU BE GOLD	22526	47439
-101	352-0168-00			2	CONN BODY, PL, EL: 10 WIRE BLACK	80009	352-0168-00
	-----			-	(A17A2P82, A17A1J66)		
-102	198-4331-00			1	WIRE SET, ELEC:	80009	198-4331-00
-103	131-0947-00			1	CONN BODY, RCPT: MALE, SNAP-IN PNL MT, 4 CONT	27264	03-09-1041
-104	175-3593-00			1	CA ASSY, SP, ELEC: 3, 18 AWG, 10.0L, 8-N	80009	175-3593-00
-105	131-0792-00			3	CONNECTOR, TERM: 18-20 AWG, CU BE GOLD PL	22526	46221
-106	131-0948-00			3	CONTACT, ELEC: CONNECTOR, BRASS TIN PL	27264	02-09-1103
-107	175-3594-00			2	CA ASSY, SP, ELEC: 2, 18 AWG, 10.0L, 8-N	80009	175-3594-00
-108	131-0792-00			2	CONNECTOR, TERM: 18-20 AWG, CU BE GOLD PL	22526	46221
-109	131-0948-00			2	CONTACT, ELEC: CONNECTOR, BRASS TIN PL	27264	02-09-1103
-110	204-0826-00			2	CONN BODY, RCPT: 2 CONT, FEMALE	27264	03-09-1021
-111	352-0205-00			1	CONN BODY, PL, EL: 9 WIRE BLACK	80009	352-0205-00
	-----			-	(FAN, FLEX-DISC-AC, FAN TO A17A1J63)		
-112	334-3379-02			3	MARKER, IDENT: MARKED GROUND SYMBOL	80009	334-3379-02

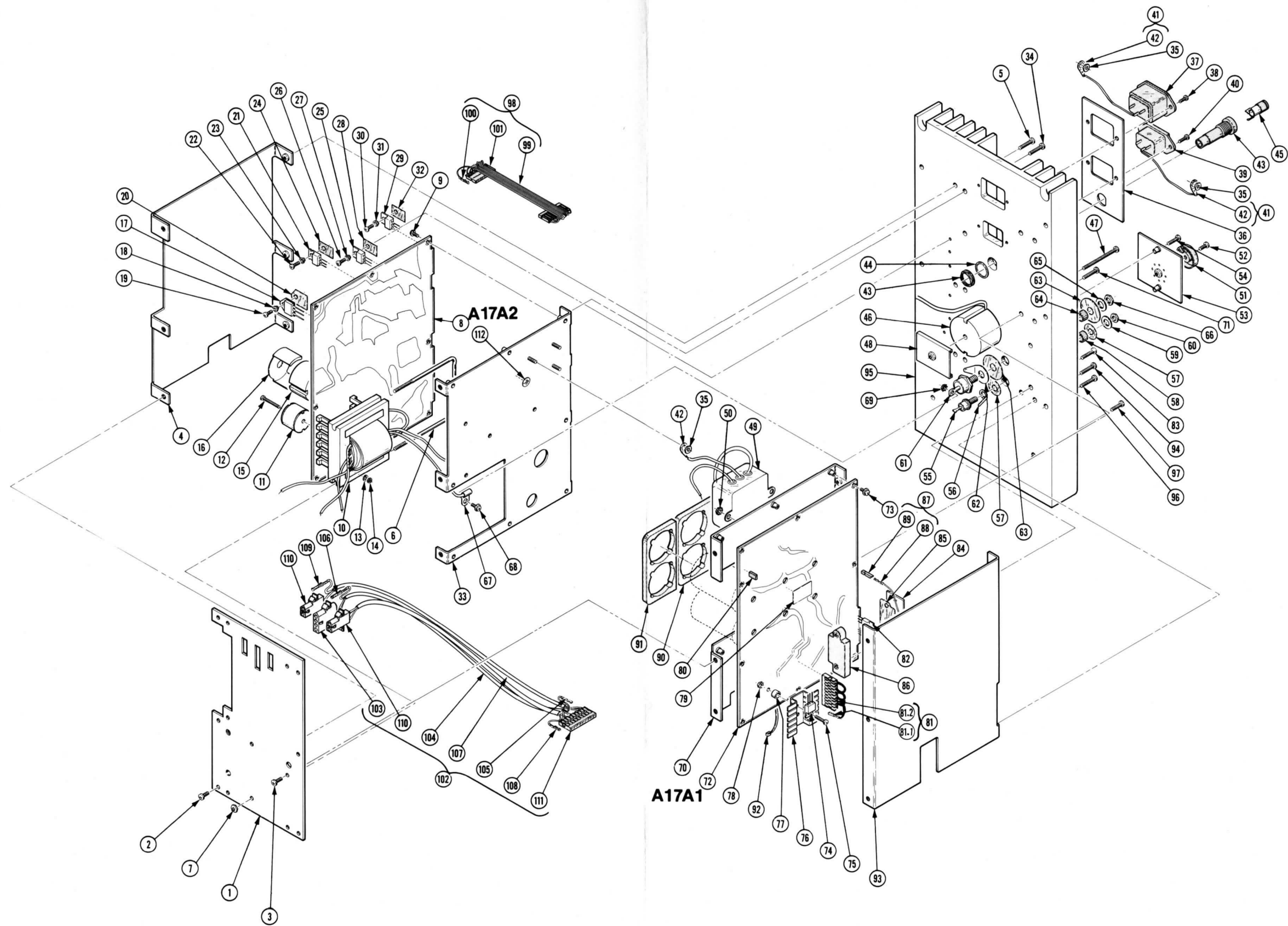

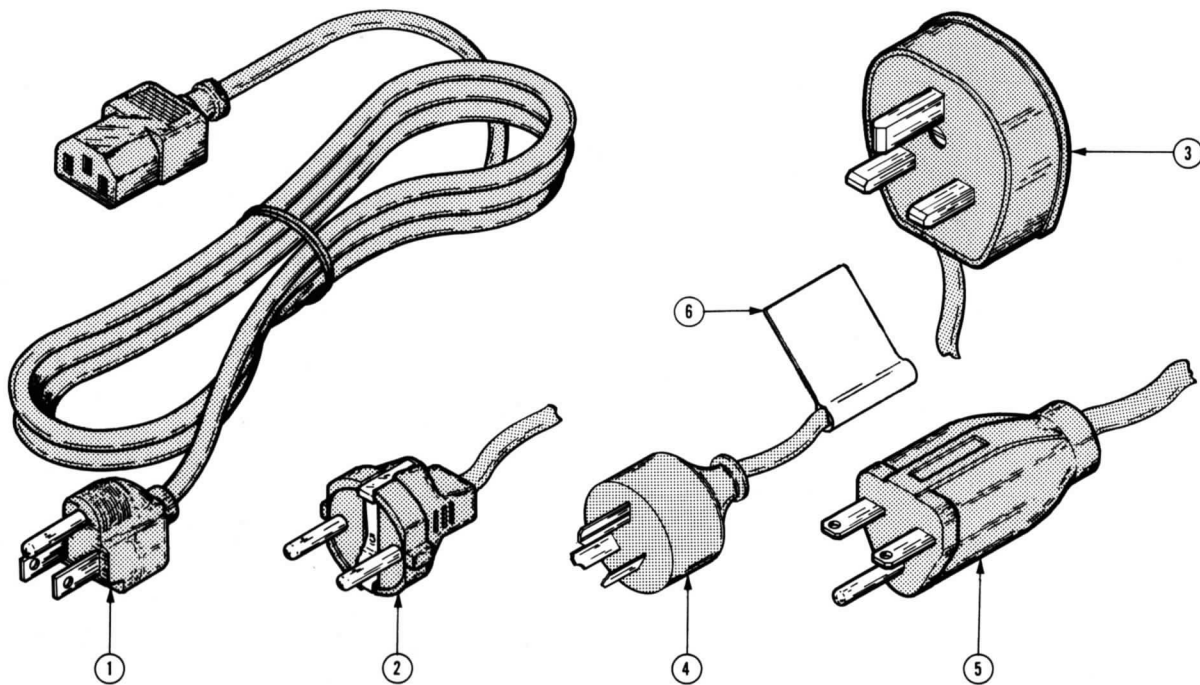

Fig. &
Index
No.

Tektronix
Part No.

Serial/Model No.
Eff Dscont

Qty 1 2 3 4 5

Name & Description

Mfr
Code

Mfr Part Number

STANDARD ACCESSORIES

10-	012-0911-00			1	CABLE, INTCON:144.0 L	04919	OBD
-1	161-0123-00			1	CABLE ASSY, PWR:3, 16 AWG, 125V, 96.01	70903	KH9028
	161-0145-00			1	CABLE ASSY, PWR:3, 0.75MM SQ, 250V, 21.0 L	70903	OBD
	-----			-	(PEDESTAL TO DISPLAY)		
-2	161-0123-01			1	CABLE ASSY, PWR:3, 0.75MM SQ, 220V, 96.0 L	80126	OBD
	-----			-	(OPTION A1 EUROPEAN ONLY)		
-3	161-0123-02			1	CABLE ASSY, PWR:3, 16 AWG, 240V, 96.0 L	80126	OBD
	-----			-	(OPTION A2 UNITED KINGDOM ONLY)		
-4	161-0123-03			1	CABLE ASSY, PWR:3, 1MM SQ, 240V, 96.0 L	S3109	1600
	-----			-	(OPTION A3 AUSTRALIAN ONLY)		
-5	161-0123-04			1	CABLE ASSY, PWR:3, 1.0MM SQ, 240V, 96.0 L	80126	OBD
	-----			-	(OPTION A4 NORTH AMERICAN ONLY)		
-6	334-3995-00			1	MARKER, IDENT: MARKED CAUTION		
	-----			-	(OPTION A3 ONLY)		
	366-1882-00			8	PUSH BUTTON: EARTH BRN, 1 X1 RELEGENDABLE	80009	366-1882-00
	334-3290-01			6	OVERLAY, KYBD: BLANK	80009	334-3290-01
	070-3672-00			1	MANUAL, TECH: OPERATORS (OVERVIEW)	80009	070-3672-00
	070-3673-00			1	MANUAL, TECH: OPERATORS	80009	070-3673-00
	070-3675-00			1	MANUAL, TECH: INSTRUCTION	80009	070-3675-00
	070-3892-00			1	MANUAL, TECH: REFERENCE	80009	070-3892-00
	000-5941-00			1	CARD, PRINTED: PACKAGING	000BR	OBD
	006-0531-00			1	STRAP, TIEDOWN, E: BLUE PLASTIC BEADED	24618	700-3688

OPTIONAL ACCESSORIES

	067-1004-00			1	FIXTURE, CAL: ALIGN GUIDE FOR FLOPPY DISC	80009	067-1004-00
	067-1005-00			1	FIXTURE, CAL: EXTENDER BOARD	80009	067-1005-00
	067-1042-00			1	FIXTURE, CAL: CURRENT LOOP LOOP BACK CONN	80009	067-1042-00
	067-1043-00			1	FIXTURE, CAL: HOST PORT LOOP LOOP BACK CONN	80009	067-1043-00
	067-1053-00			1	FIXTURE, CAL: EXTENDER CABLE	80009	067-1053-00
	016-0460-00			1	GRID, TABLET: 20 X 20 LINES, 11.0 X 11.0	000IL	55-5531SP
	016-0461-00			1	GRID, TABLET: 20 X 20 LINES, 30.0 X 40.0	000IL	55-5541SP
	070-3820-00			1	MANUAL, TECH: SERVICE, VOL 01	80009	070-3820-00
	070-3818-00			1	MANUAL, TECH: SERVICE, VOL 02	80009	070-3818-00
	119-1376-01			1	FLEX DISKETTE: ONE SIDED, DBLDENSITY	80009	119-1376-01

OPTIONS

OPT	ORDER	QTY	DESCRIPTION
A1			240V EURO PLUG:16A
A2			240V UK PLUG:13A
A3			240V AUSTRALIAN PLUG:13A
A4			240V NA:15A
01	020-0606-00		EXT COMMUNICATION:INCL HALF DUPLEX BLOCK MODE AND DOWN LOADER
02	021-0323-00		INTERFACE:CURRENT LOOP (REFER TO APPROPRIATE OPTION SERVICE MANUAL)
10	021-0313-00		INTERFACE:3 PORT PERIPHERAL (REFER TO APPROPRIATE OPTION SERVICE MANUAL)
13	4110F13		GRAPHIC TABLET:11 X 11 W/PEN (REFER TO APPROPRIATE OPTION SERVICE MANUAL)
14	4110F14		GRAPHIC TABLET:30 X 40 W/PEN (REFER TO APPROPRIATE OPTION SERVICE MANUAL)
24	018-0159-00	1	ADDED MEMORY:32K BYTES OF RAM
	018-0160-00	1	
25	018-0159-00	1	ADDED MEMORY:64K BYTES OF RAM
	018-0160-00	2	
26	018-0159-00	1	ADDED MEMORY:96K BYTES OF RAM
	018-0160-00	3	
27	018-0160-00	1	ADDED MEMORY:128K BYTES OF RAM
	018-0159-00	4	
28	018-0159-00	2	ADDED MEMORY:256K BYTES OF RAM
	018-0160-00	8	
29	018-0159-00	4	ADDED MEMORY:512K BYTES OF RAM
	018-0160-00	16	
30	062-6363-00	1	LOCAL EASY GRAPHING
31	-----		COLOR ENHANCED REFRESHED
40	018-0163-00		BUS EXTENDER:10 SLOT PERIPHERAL,NOMINAL VOLTAGE
41	018-0164-00		BUS EXTENDER:10 SLOT PERIPHERAL,90-110V
42	4110F42		SINGLE FLEXIBLE DISC:W/CONTROLLER
	4110F44		ADD SECOND FLEXIBLE DISC (REFER TO APPROPRIATE OPTION SERVICE MANUAL)
43	4110F43		DUAL FLEXIBLE DISC:W/CONTROLLER (REFER TO APPROPRIATE OPTION SERVICE MANUAL)
52			VOLTAGE CHANGE:SPECIFY VOLTAGE
4A	020-0597-00		UNITED KINGDOM KEYBOARD
4C	020-0599-00		SWEDISH KEYBOARD
4E	020-0605-00		APL KEYBOARD
4F	020-0603-00		DANISH/NORWEGIAN KEYBOARD

OPTIONS

Appendix A

SIGNAL LIST

All named signals of the 4114 terminal are included in this alphabetical list. The first line of the entry under the "Explanation" column is an English-language description of the signal name mnemonic in the "Signal" column. There are two kinds of abbreviations used in the "Explanation" entries: abbreviations for blocks of circuitry named on the schematics and abbreviations for LSI integrated circuits.

Some signals on the Processor, RAM/ROM, and RAM Controller boards have the same names although they are not physically the same signals. They do, however, perform similar functions on their respective boards. Some instances are A0-19, CAS, and DIN0-15.

Bus signals are designated by their alphabetic name to which is appended the least significant bit (LSB) separated by a hyphen from the most significant bit (MSB). An example is the Processor board address bus, A0-19. There are 20 lines (bits) in this bus. A0 is the LSB and A19 is the MSB.

PROCESSOR BOARD BLOCKS

ADE	Address Decoding	MPUC	Microprocessor Control
ADR	Address Drivers	MTG	MPU Timing Generator
BCD	Bus Command Driver	NVR	Non-Volatile RAM
BCG	Bus Clock Generator	PT&BRG	Programmable Timer & Baud Rate Generator
BTD	Bus Timeout Detector		
BTL	Bus Transfer Logic	ROMS	ROMs
DD/R	Data Drivers/Receivers	RCI	RS-232 Communications Interface
IC	Interrupt Controller	RSCD	RS-232 State Change Detector
KC	Keyboard Controller	SI	Status Input
MPU	Microprocessor		

LSI CIRCUITS

PIT	Programmable Interval Timer	PI MPU	Peripheral Interface Microprocessor
PIC	Programmable Interrupt Controller	DRC	Dynamic RAM Controller
MPU	Microprocessor	BC	Bus Controller

SIGNAL LIST

Signal	Source; Destination	Explanation
1STINTA-0	3-2; 3-1	First Interrupt Acknowledge. This Processor board signal indicates when the first of two interrupt acknowledge (INTA) cycles is occurring. Only the second INTA contains useful information.
A0-19	3-2; 3-3, 3-4, 3-5	(Local) Address (Bits 0 through 19). This is the Processor board address bus. It is created in the address drivers block from the MPU ADO-AD19 outputs. Note that some of these bits appear also on the RAM/ROM and RAM Controller boards with similar functions.
ABS-0	8-4; 9-5	Absolute Position. Indicates to the Vector Generator that an absolute positioning operation is in progress.
ACK1-0	3-1; 3-1	Acknowledge 1. This system bus signal can be used as a slave response for no MPU wait states. The Processor board uses ACK1 to terminate a bus data transfer when it detects a bus timeout condition from the BTDC circuitry.
ACK2-0	5-1; 3-1	Acknowledge 2. ACK2 serves as an advanced transfer acknowledge to eliminate WAIT states in the MPU. The signal derives from SACK-0 which is output by the timing and control block inside the dynamic RAM controller. SACK-0 indicates the beginning of a memory access cycle.

Signal	Source; Destination	Explanation
ADO-19	3-1, 3-2; 3-2	(MPU) Address/Data (Bits 0 through 19). These signals are the time-multiplexed memory I/O address and data bus output from the MPU. These bits are also input for data.
ADRO-19	3-2; P101	(System) Address (bits 0 through 19). These are the system bus address lines.
AIOWC-0	3-2; 3-1	Advanced IO Write Command. This signal gives system bus IO devices early indication of a write instruction. The timing is the same as a read command.
ALE-1	3-2; 3-1, 3-3	Address Latch Enable. ALE-1 strobes an address into the ADE block. It also synchronizes the Microprocessor Timing Generator, and DEGLITCHES the ROM bank decoder.
AMWC-0	3-2; 3-1	Advanced Memory Write Command. AMWC-0 gives early indication of a write instruction to the system bus memory. The timing is the same as a read command — MRDC.
ANODE	18-1; 19-1	(crt) Anode. Passes through a current limiting resistor in the Hard Copy Amplifier board to the anode of the crt.

SIGNAL LIST

Signal	Source; Destination	Explanation
ANTIBURN	14-2; 17-1	Antiburn. (Made up from LA and SA ANTIBURN signals on schematic.) If positive, decreases the Z-Axis amplifier drive, reducing the CRT writing beam intensity. Goes positive when deflection approaches zero velocity.
AWT-0	3-1; 3-2, 3-4, 3-5	Advanced Write. This is the advanced write command to all on-board devices. AWT is derived from the MPU status lines and the Microprocessor Timing Generator.
BANKIN-0	7-2; 7-1	Bank In. BANKIN is used in the address decoding logic on the RAM Controller board to indicate the presence or absence of a RAM Array board.
BBCLK-1	3-1; 3-5	Buffered Bus Clock. BBCLK is a 4.9152 MHz signal which synchronizes the bus transfer logic and is the frequency source for the Programmable Timer and (Transmit) Baud Rate Generator block.
BCLK-0	3-1; 3-1	Bus Clock. BCLK is the system bus clock. It is a 4.9152 MHz square wave and is used by bus devices to synchronize bus master transfers. It is also used as a stable frequency source.

Signal	Source; Destination	Explanation
BHEN-0	3-2; P101	Byte High Enable. On the Processor board, ULBHEN is latched and then driven onto the system bus as BHEN. BHEN enables the high byte — D8-15 — on read, write, and interrupt acknowledge cycles.
BPRN-0	1-2; 3-1	Bus Priority In. BPRN is a signal from the bus priority logic on the Motherboard that informs a potential bus master board that it has permission to become bus master.
BREQ-0	3-1; P101	Bus Request. BRQ is a signal from a potential bus master board to the bus priority logic on the Motherboard that indicates that the potential bus master board needs to become the actual bus master.
BRITE-0	8-4; 16-1	Brite. A TTL low from the Display Controller activates BRITE Intensity adjustable by R415 in the Intensity Control Logic. In combination with low level on DEFOCUS-0, the BRITE-DEFOCUS mode is useful for displaying wide vectors.

SIGNAL LIST

Signal	Source; Destination	Explanation
BUSAEN-0	3-1; 3-2	BUS Address Enable. BUSAEN indicates that a board is bus master of the system bus. BUSAEN is input to the AEN input of the bus controller IC. AEN enables the bus controller to output the bus commands MRDC, MWTC, AMWC, IORDC, etc. BUSAEN is gated with INTA and input to the INTA input of the PIC.
BUSGRT-1	3-1; 3-5	Bus Grant. This signal is similar to BUSAEN, but has a slight timing difference.
BUSY-0	3-1; 3-1	(Bus) Busy. BUSY indicates that a bus master is currently using the system bus. BUSY delays bus master transfer until the current bus master is done.
CAS-0	7-1; 7-2 5-1; 5-2, 6-1	Column Address Strobe. This signal is generated by the DRC on both the RAM/ROM and the RAM Controller boards. CAS strobes the seven multiplexed column address bits appearing on RA0-6 into the RAMs on the RAM Array board.
CATHODE	18-2; 19-1	(crt) Cathode. Ties cathode of crt to ground.

Signal	Source; Destination	Explanation
CBRQ-0	3-1; 3-1	Common Bus Request. CBRQ is used by potential bus masters to request bus mastership from higher priority bus masters. CBRQ is generated by the Processor board along with BRQ. The Processor board also listens to CBRQ and gives up the bus when another board asserts CBRQ.
CCEN-1	9-1; 9-2	Completion Counter Enable. Enables Completion Counter during vector generation.
CE1 & CE2	18-2; 19-1	Collimation Electrodes, 1 and 2. The collimation electrodes, CE1 and CE2, are electronic lenses that cause a uniform flood gun beam pattern over the target.
CENTER-0	15-1; 14-1	Centering. When low, it inhibits and resets the operation of the Origin Shift Counter. (not used in the 4114 display)
CLK-1	3-1; 3-2	Clock. CLK is a direct output of the Clock Generator IC. It outputs a 4.9152 MHz square wave with a one third duty cycle. All blocks that must be synchronized with the local processor bus use this signal.

SIGNAL LIST

Signal	Source; Destination	Explanation
CLKDIS-0	P129; 5-1 P166; 7-1	Clock Disable. A TTL logic low level applied to this input pin disables the clock circuitry on the RAM/ROM or the RAM Controller board. (This is a test point for factory use only).
CMD-1	3-4; 3-5	Command. CMD is the logical OR of RD and AWT on the Processor board.
COMINT-0	3-5; 3-2	Communications Interrupt. COMINT is the RS-232 Communications Interface received character interrupt signal. Other RS-232 interrupts are included in the TIMERINT signal.
CTS-1	P102; 3-5	Clear To Send. CTS is an RS-232 status input.
CUTX-0	9-3; 9-5	Cut X (axis). Cuts off CRT beam when scissoring occurs in the X axis.
CUTY-0	9-4; 9-5	Cut Y (axis). Cuts off CRT beam when scissoring occurs in the Y axis.
CX0-11	9-3; 9-2	X Shift Register Data. Parallel load data for X Counter.
CY0-11	9-4; 9-4	Y Shift Register Data. Parallel load data for Y Counter.

Signal	Source; Destination	Explanation
DO-15	3-2; 3-3, 3-4, 3-5	(Local) Data (Bus). These lines are the local data bus for the Processor board.
DAT0-15	3-2; P101, 8-3	(System) Data (Bus). These line are the system data bus.
DBUSY-0	18-1; 8-1, 8-2, 8-3, 8-4, 9-2	Display Busy. When low, it indicates that the display is busy in HOLD mode, erasing the screen, or in Hard Copy operation. This line states that the monitor is busy and cannot accept further information until brought out of one of these modes.
DCD-1	P102; 3-5	Data Carrier Detect. DCD is an RS-232 status input.
DCLK-1	9-1; 8-4	Dot (or dash) Clock. Clock for dot (or dash) pattern.
DCZ-1	9-2; 9-1	Displacement Counter Zero. Indicates that the displacement between characters is either completed or not to be done.
DD0-15	8-3; 9-1, 9-3	Display Data Bits 0 to 15. Sixteen bits of data transferred between the Display Controller and the Vector Generator (or optional board).

SIGNAL LIST

Signal	Source; Destination	Explanation
DEFO-CUS-0	8-4; 16-1	Defocus. When low, the focus of the crt writing beam is reduced, producing a slightly wider trace (defocused). When high, the writing beam is focused. The use of the DEFO-CUS-0 signal line allows a focused or defocused crt writing beam when used in combination with WRITE-THRU, BRITE, and NORMAL.
DINO-15	5-2; 6-1 7-2; 6-1	Data In Bits 0 through 15. During RAM write operations, these 16 data bits contain the data that is written into RAM on the RAM Array board.
DINLSB-0	7-1; 7-2	Data Input Enable Least Significant Byte. During RAM write operations, DINLSB enables the data input buffer for the least significant byte of data to drive data from the bus onto RAM data lines DIN0-7 to the RAM Array boards.
DINMSB-0	7-1; 7-2	Data Input Enable Most Significant Byte. During RAM write operations, DINMSB enables the data input buffer for the most significant byte of data to drive data from the bus onto RAM data lines DIN8-15 to the RAM Array boards.
DIS. SIZE IN.	J5005; HCU	Display Size Information. Tied to ground (logical low). When tied low, it informs the hard copy unit that it is scanning a 19 inch display.

Signal	Source; Destination	Explanation
DOUT-0	7-1; 7-2 5-1; 5-2	Data Output Enable. During RAM read operations, DOUT enables the Data Output Latches to output their data to the system bus.
DOUT0-15	6-1; 5-2 6-1; 7-2	Data Output Bits 0 through 15. These 16 data bits from the RAM Array board contain the RAM data output bits during RAM read operations.
DPC	9-2; 15-1	Display Power Control. Causes display ac power to be turned on. 10mA at + 9 to + 12 V.
DS-1	9-1; 9-1	Data Shift. Indicates the data in the shift registers is not normalized and requires shifting.
DSCAL-0	9-1; 9-2	Delayed Scale. Scale signal for vector being set up.
DSR-1	P102; 3-5	Data Set Ready. DSR is an RS-232 status input.
DT-1/R-0	3-2; 3-4	Data Transmit/Receive. DT-1/R-0 is a direct output of the bus controller. A high on this line indicates a WRITE to IO or memory and a low is a READ.
DTR-1	3-5; P102	Data Terminal Ready. DTR is an RS-232 status output.

SIGNAL LIST

Signal	Source; Destination	Explanation
DYNAMIC FOCUS	15-1; 16-1	Dynamic Focus. This signal modifies the focus electrode voltage to maintain a consistently focused writing beam over the display screen.
ERASE TRIGGER	13-1; 13-2	Erase Trigger. Triggers the crt to erase via ERASE-0 line.
ERASE-0	8-2; 13-1	Erase. Initiates the erase cycle in the storage board circuits. Erases the crt. Must be greater than 2μs. A READ-0 or WAIT-0 signal prevents erasure during hard copy operation.
FAST RAMP	HCU; 14-1	Fast Ramp. Analog deflection voltage from the HCU which controls the vertical deflection during the hard copy scan. (There are "+" and "-" FAST RAMPs on the schematics.)
FG FIL	16-1; 19-1	Flood Gun Filaments. Flood Gun filaments (± FG FIL on schematic) of crt. Driven by ± 15 v from low voltage power supply.
GBSY-1	8-4; 9-1	Generator Busy. Vector generator is not ready to accept new vector data.

Signal	Source; Destination	Explanation
GBUSY	8-4; 18-1	Generator Busy. Optional signal that can be used to reset the view erase counters. A 100 ns or greater pulse is required. A VIEW-0 signal also resets the view erase counters. (There is a view reset strap option between GBUSY and Z-AXIS.)
GRUN-1	9-2; 8-4	Generator Running. Vector generator is drawing a vector.
HC INTENSITY	HCU; 17-1	Hard Copy Intensity. Controls the crt writing beam intensity by adjustment of R228 (Hard Copy intensity adjustment).
HCS-0	18-1; 17-1	Hard Copy Scan. Enables operation of Hard Copy circuitry. HCS-0 is asserted by either READ-0 or WAIT-0 (from the hard copy unit) going low. Initiates crt scan by the HCU.
HCS-1	18-1; 18-2, 19-1	Hard Copy Scan. Inverted HCS-0. Enables operation of Hard Copy circuitry. Refer to signal HCS-0.

SIGNAL LIST

Signal	Source; Destination	Explanation
HCU-0	HCU; 8-2	Hard Copy Unit. Indicates to the display controller that the Hard Copy Unit is capable of accepting a MAKECOPY-0 request.
HOLD-0	18-1; 14-1	Hold. Connects the channel switch to a separate set of inputs that are connected to ground when Hold mode is initiated. The grounded inputs prevent beam deflection and assure minimum deflection amplifier power dissipation during Hold mode. (Strap option on Deflection Amplifier board, operational in the IN position.)
IN-0	5-2; 6-1	In. IN is used with OUT to indicate the presence or absence of a RAM Array board.
INH-0	--; 5-1	(Read) Inhibit. When true low, INH inhibits memory circuitry from outputting its data onto the system bus during a read operation of the memory circuitry. See INHIBIT. INH may be output by test circuitry. Currently not used.

Signal	Source; Destination	Explanation
INHIBIT-0	5-1; 5-3	Inhibit. This signal is a buffered version of the system bus signal INH. This signal, when true low, inhibits the RAM/ROM board from outputting its data during RAM read or ROM read operations.
INIT-0	17-1; 3-1, 3-4, 9-1	Initialize. INIT is used to generate reset which goes directly to the MPU and does a power-up reset operation. It also resets much of the sequential logic on the Processor board.
INT0-7	P101; 3-2	Interrupt 0 through 7. INT0-7 are interrupt request signals to the Processor board. INT0,4, or 5 can be generated by Processor board devices.
INTA-0	3-2; 3-1, 3-2	Interrupt Acknowledge. INTA is generated on the Processor board and is received by slave PICs on other boards. INTA notifies the slave PIC that its interrupt is acknowledged and it can put vectoring data on the System data bus.

SIGNAL LIST

Signal	Source; Destination	Explanation
INTER-0	HCU; 17-1	Interrogate. This is the hard copy interrogate pulse from the hard copy unit (HCU). As a result the crt writing beam is pulsed (100 ns pulse width) and a target information signal, TARSIG-0 is developed.
INTR-1	3-2; 3-1	Interrupt. INTR is a direct output of the INT pin of the PIC in the IC block. The signal is input directly to the MPU INTR input. INTR is the interrupt to the MPU.
IORC-0	3-2; 3-1	IO Read Command. This signal, when low, indicates that an IO device should drive its data onto the system bus.
IOWC-0	3-2; P101	IO Write Command. This signal, when low, indicates that an IO device should read data on the system bus.
KA0-3	3-4; P103	Keyboard Address 0 through 3. These signal lines carry key matrix column addresses in addition to LED address and on-off information.

Signal	Source; Destination	Explanation
KD0-7	4-1; 3-4	Keyboard Data 0 through 7. These lines carry key matrix data in addition to thumbwheel Grey code data.
KBDINT-0	4-1; 3-2	Keyboard Interrupt. This signal is the interrupt for the keyboard. It is output from Pin 24 of the PIMPU and input to the IC block as INT4 into the PIC.
KBT3-1	P104; 3-4	Keyboard Test. KBT is the test input to the KC MPU Keyboard Controller.
KSTRB-0	3-4; 4-1	Keyboard Strobe. KSTRB latches KA0-KA3 data into the Keyboard board circuitry.
KWR-0	3-4; 4-1	Keyboard Write. KWR latches KA0-KA3 into the Keyboard circuitry that controls the LEDs.
LBHE-0	3-2; 3-4	Latched Byte High Enable. LBHE is the Processor board equivalent of the system bus signal, BHEN.
LCNT-0,-1	9-1; 9-3, 9-4	Load Count. Enables counter parallel load.

SIGNAL LIST

Signal	Source; Destination	Explanation
ORIGIN-1	18-1; 14-1	Origin. During erase cycle from Storage board, triggers the origin shift counter on the Deflection Amplifier board to shift the axes slightly on the next page of screen written data. Feature increases crt screen life.
OUT-0	6-1; 5-2 6-1; 7-2	Out. OUT is used with IN to indicate the presence or absence of a RAM Array board.
OUT0-1	3-5; 3-1	Output 0. OUT0 is the output of a 16-bit programmable down counter. This provides variable timing delays for the system firmware. In the BTD block, it clocks the bus timeout counter whose output to the system bus is ACK1.
PD-0,-1	9-5; 9-5	Pump Down. X axis current switch signal.
PL-0,-1	9-5; 9-5	Pump Left. Y axis current switch signal.
PR-0,-1	9-5; 9-5	Pump Right. Y axis current switch signal.
PU-0,-1	9-5; 9-5	Pump Up. X axis current switch signal.
QS1-2	3-1; J104	Queue Status 1 and 2. QS1-2 are direct outputs of the MPU that are not used on the Processor board.

Signal	Source; Destination	Explanation
RA0-6	5-1;5-1 7-1; 7-2	RAM Address Bits 0 through 6. These signals contain the seven multiplexed row and column addresses from the DRC to the dynamic RAMs on the RAM Array board.
RAM-WRITE-0	5-1; 5-2	RAM Write. RAMWRITE indicates to the DRC and the data input receivers on the RAM/ROM board that a RAM write operation has been requested.
RAS-0	5-1; 5-2	Row Address Strobe. RAS is generated by the DRC on the RAM/ROM board. RAS strobes the seven multiplexed row address bits appearing on RA0-6 into the RAMs on the RAM Array board.
RAS0-3	7-1; 7-2	Row Address Strobe 0 through 3. These signals are generated by the DRC on the RAM Controller board. RAS0-3 strobe the seven multiplexed row address bits appearing on RA0-6 into the RAMs on the appropriate RAM Array board (RAM Bank 0 through 3).
RCLK-1	P102; 3-5	Receive Clock. RCLK is an RS-232 external clock signal generated by a modem or other external device. RCLK can be used to clock data into the Processor board's UART.

SIGNAL LIST

Signal	Source; Destination	Explanation
RD-0	3-1; 3-2, 3-4, 3-5	Read. If RD is low, it indicates that the MPU is performing an IO or memory read cycle, either to the local or system bus.
RDATA-1	P102; 3-5	Receive Data. RDATA is the RS-232 serial data input from a modem or other external device to the Processor board.
RDY-1	J104; 3-1	Ready. RDY is the MPU RDY signal output to test connector J104.
RDYAND-0	J104; 3-1	Ready And. RDYAND is an input from a test device connected to J104 that can disable the RDY line to the MPU, causing the MPU to enter a WAIT state.
RDYOR-0	J104; 3-1	Ready Or. RDYOR is an input from a test device connected to J104 that can activate the RDY line to the MPU, causing the MPU to exit a WAIT state.
READ-0	5-1; 5-3	Read. READ is the buffered version of the system bus signal MRDC.

Signal	Source; Destination	Explanation
READ-0	HCU; 18-1,- 14-1	Read. Develops HCS-0 and HCS-1 in the copy control section. READ-0 causes the channel shift and origin shift to use the the SLOW and FAST RAMP signals (also from the HCU) to provide LA and SA outputs from the Deflector Amplifier.
RELX-0,-1	9-1; 9-1	Relative X Axis. The vector operation is relative in the X axis.
RELY-0,-1	9-1; 9-1	Relative Y Axis. The vector operation is relative in the Y axis.
REMOTE COPY-0	8-2; HCU	Remote Copy. Caused by Display Controller switch going low. Initiates a hard copy cycle (makes a copy). A direct line from the MAKE COPY-0 signal, which acts as a reference for the Hard Copy Unit. Informs the HCU that it is being triggered from a source remote to the HCU.
RING-1	P102; 3-5	Ring. RING is an RS-232 status input indicating that an auto-answering modem is ringing.

SIGNAL LIST

Signal	Source; Destination	Explanation
ROM-READ-1	5-3; 5-1	ROM Read. ROMREAD indicates that a ROM read operation is in progress. This signal is used to generate an acknowledge signal (ACK1 or ACK2) to the bus master.
RQ-0/GT [0/1]	3-1; J104	Request/Grant. RQ/GT0 is the local MPU bus request/grant signal. It is available to J104 test connector, but is not used on-board.
RSCNT-0	9-1; 9-2	Reset Count. Clears completion shift register for new shift data.
RST-0	3-1; 3-2, 3-4, 3-5	Reset. RST-0 is RST-1 inverted.
RST-1	3-1; 3-2, 3-4, 3-5	Reset. RST is derived from the system bus signal INIT and is synchronized to the MPU clock. RST resets the MPU and other devices on the Processor board.
RTS-1	3-5; P102	Request To Send. RTS is an RS-232 signal generated by the RCI block on the Processor board.
RXSGN-0	9-1; 9-3	Reset X Sign. Clears X sign bit between vectors.

Signal	Source; Destination	Explanation
S0-2	3-1; 3-2	Status 0 through 2. These status lines have eight states taken together and indicate whether an interrupt acknowledge read IO, write IO, halt, code access, read memory, or write memory is occurring. The bus controller IC in the BCD block interprets the S0, S1, and S2 signals and outputs INTA, IOWC, AIOWC, IORC, MRDC, MWTC, AMWC.
S7-1/ BHE-0	3-1; 3-2	Status 7/Byte High Enable. This signal is interpreted as BHE during the MPU state T1. It enables D8—D15 onto the local data bus. During T2, T3, or T4 this signal is interpreted as S7.
SCAL-0	8-3; 9-1	Scale Enable. Enables the vector scaling logic.
SDCD-1	P102; 3-5	Secondary Data Carrier Detect. SDCD is the RS-232 secondary data carrier detect signal.
SHEN-1	9-1; 9-3, 9-4	Shift Enable. Enables the X and Y Shift Registers.
SHFTX-1	9-1; 9-3	Shift X Axis. Shifts X data.

SIGNAL LIST

Signal	Source; Destination	Explanation
SHFTY-1	9-1; 9-2, 9-4	Shift Y Axis. Shifts Y data.
SLOW RAMP	HCU; 14-1	Slow Ramp. Analog deflection voltage from the HCU which controls the horizontal deflection during the hard copy scan. (There are "+" and "-" SLOW RAMPs on the schematics.)
SLU-0	14-2; 8-3, 8-4	Slew. Indicates a temporary wait for the display controller while the deflection circuits are lagging the deflection inputs and establishing the new deflection position.
SRTS(A)-1	3-5; P102	Secondary Request To Send (RS-232A). SRTS(A) is the RS-232A secondary request to send output. SRTS is defined on a different connector pin for RS-232C, and so is strappable on the board.
SRTS(C)-1	3-5; P102	Secondary Request To Send (RS-232C). SRTS(C) is the RS-232C counterpart to SRTS(A) above.
STATEN-0	3-5; 3-1	Status Enable. STATEN is low during an MPU read of status at IO location X'00ED' or X'00EF'.

Signal	Source; Destination	Explanation
STEPX-0	9-1; 9-2, 9-3	Step X Axis. Clocks X Counter to set character spacing.
STEST-0	P101; 3-5	Self Test. STEST is a line on the system bus which the Processor can read via a 3-state driver. The line is low when the self-test button is pressed.
SVECT-0	8-2; 9-1, 9-3	Short Vector. Data is in short vector format (during vector data transfer).
SVECT-1	8-2; 8-4	Short Vector. Data is in short vector format (during vector data transfer).
T3W4-1	3-1; 3-3	(State) T3, Wait, 4. T3W4 is high when the MPU is in a T3, T4, or TW (WAIT) state. T3W4 enables on-board data transceivers.
T4I-0	3-1; 3-3	(State) T4, Idle. T4I is low during MPU T4 and TI (idle) states. It turns off data transceivers during T4 in on-board memory and IO READs.
TARGET	18-2; 19-1	Target. Voltage established at the inside face (screen) of the crt.

SIGNAL LIST

Signal	Source; Destination	Explanation
TARSIG-0	19-1; HCU	Target. Display information signal from the target sent to the HCU when a hard copy is being made. Goes low when the scan crosses a written area on the crt screen.
TCLK-1	P102; 3-5	Transmit Clock. TCLK is the RS-232 transmit clock output from the Processor board.
TDATA-1	3-5; P102	Transmitted Data. TDATA is the RS-232 signal on which serial data is transmitted from the Processor board.
TEST-0	J104; 3-1	Test. TEST is an input to the MPU Processor. It is available at Pin 50 on the test connector, but is not used on-board.
TEST-1	3-5; 3-1	Test. TEST is a signal that the processor can set to enable the Clock Generator to locally terminate an on-board or off-board READ or WRITE operation. The signal is used for testing purposes, and is similar in function to the BTD circuit.

Signal	Source; Destination	Explanation
TIMERINT-0	3-5; 3-2	Timer Interrupt. TIMERINT indicates the presence of either a PIT timer1 interrupt, a UART TXEMT interrupt, a UART TXRDY interrupt, an RS-232 status change interrupt, or an PIT TIMER0 interrupt (via RSCD).
TIMR1-1	3-5; 3-1	Timer 1. This signal is output from the O1 pin of the PIT. O1 is the output of a 16-bit programmable down counter.
TRU Z	17-1; 18-1, 14-2	True Z (axis). Represents the true Z-Axis (always active high). Turns on crt writing beam depending on the status of the intensity control logic section. Overrides Antibern circuitry in the first few microseconds of operation, due to the time lag of the Antibern circuitry, so as not to blank out any beginning information. (See also Z AXIS signal definition.)
TXC-0	3-5; P102	Transmit Clock. TXC is the buffered output of the PIT timer1 to RS-232 connector. It is not presently used.
UBCLK-1	3-1; 3-4, 3-5	Unbuffered Bus Clock. UBCLK is a 4.9152 MHz square wave clock provided to clock the UART and PIMPU.

SIGNAL LIST

Signal	Source; Destination	Explanation
ULBHEN-0	3-1; 3-2	Unlatched Byte High Enable. ULBHEN is an MPU output. See BHEN for a description of this signal.
VAVIL-1	9-1; 8-2, 9-4	Vector Available. Vector data is available to vector set-up logic but has not yet been completely processed.
VCLK-0,-1	9-1; 9-2, 9-5	Vector Clock. 12 MHz clock signal.
VCLKA-1	9-1; 9-5	Vector Clock A. 12 MHz clock signal.
VCOMP-1	9-2; 9-2	Vector Completed. Completion Counter has detected end of vector.
VIEW-0	8-1; 18-1	View. Resets the view erase counters. (GBUSY or Z-AXIS will also do this, depending on the placement of the view reset strap).
VSTRT-0	9-1; 8-4	Vector Start. Vector generation has started.
VSTRT-1	8-4; 8-2	Vector Start. Vector generation has started.
WAIT-0	HCU; 18-1	Wait. Remains low until the display screen has been scanned. (Applies only to a hard copy unit with multiplexer option.)

Signal	Source; Destination	Explanation
WELSB-0	5-1; 5-2 7-1; 7-2	Write Enable Least Significant Byte. WELSB is a control strobe to the RAM Array board indicating that a write operation to the least significant byte of RAM is in progress.
WEMSB-0	5-1; 5-2 7-1; 7-2	Write Enable Most Significant Byte. WEMSB is a control strobe to the RAM Array board indicating that a write operation to the most significant byte of RAM is in progress.
WRITE-THRU-0	8-4; 17-1	Write Thru. Selects WRITE-THRU INTENSITY CONTROL (R227-Coarse Write Thru) and disables NORMAL and BRITE INTENSITY controls.
WT INTENSITY	15-1; 17-1	Write-Thru Intensity. Controls the WRITE-THRU INTENSITY by R227 adjustment (see WRITE-THRU-0).
X+	9-5; 14-1	X (axis). X-axis input to monitor. (Written + X and -X on schematics.)
X0-11	9-4; 9-5	X DAC Input Data Bits. Scissored data to X DAC.

SIGNAL LIST

Signal	Source; Destination	Explanation
XACK-0	5-1; 5-2 7-1; 7-2	Transfer Acknowledge. The DRC generates XACK to acknowledge that a RAM read or write operation is in progress. This signal latches the RAM output data into the Data Output Latches.
XCLK-0	P129; 5-1 P166; 7-1	External Clock. When the Clock circuitry is disabled using CLKDIS , an external TTL clock signal may be fed into XCLK to control the DRC. (This is a test point for factory use only.)
XE-1	9-3; 9-5	X Enable. Enables X Decoder gates.
XS-0	9-3; 9-5	X Sign. Sets X vector directions.
XTRA-1	6-1; none	Extra. EXTRA is an extra line of the RAM Array board that is currently not used. It may be used in the future.
Y+	9-5; 14-1	Y (Axis). Y axis input to the monitor. (There are "+" and "-" Y axis signals on the schematics.)
Y0-11	9-4;9-5	Y DAC Input Data. Scissored data for Y DAC.
YE-1	9-4; 9-5	Y Enable. Enables Y Decoder gates.

Signal	Source; Destination	Explanation
YS-1	9-4; 9-5	Y Sign. Sets y vector direction.
Z-AXIS	9-5; 18-1, 17-1	Z-axis. True signal turns on the crt writing beam depending upon the status of the intensity control logic section. Also can be strapped to accept either TTL state (high or low) input signal.
ZOUT-1	9-5; 9-1	Z Axis Output. Crt beam current control.
ZVECT-0	9-2; 9-1	Zero Length Vector. Indicates vector length is zero.

Appendix B

ASCII CODE AND KEYCODE CHARTS

This appendix includes a standard ASCII code chart and additional ASCII code charts which define the specific characters used as parameters (indicated by unshaded areas).

The code charts are:

Table Description

- B-1 ASCII Code Chart
- B-2 Characters Used in <Char> Parameters
- B-3 Characters Used in <Int> and <Int+> Parameters

Table Description

- B-4 Characters Used in <Int-Report> Parameters
- B-5 Characters Used in <Xy> Parameters
- B-6 Characters Used in <Xy-Report> Parameters
- B-7 United Kingdom Character Set
- B-8 Swedish Character Set
- B-9 APL Character Set
- B-10 Danish/Norwegian Character Set
- B-11 Keyboard Keycodes

**Table B-1
ASCII (ISO-7-US) CODE CHART**

BITS		0 0 0	0 0 1	0 1 0	0 1 1	1 0 0	1 0 1	1 1 0	1 1 1		
B7	B6	CONTROL		FIGURES		UPPERCASE		LOWERCASE			
B4	B3	B2	B1								
0	0	0	0	NUL	DLE	SP	0	@	P	\	p
0	0	0	1	SOH	DC1	!	1	A	Q	a	q
0	0	1	0	STX	DC2	"	2	B	R	b	r
0	0	1	1	ETX	DC3	#	3	C	S	c	s
0	1	0	0	EOT	DC4	\$	4	D	T	d	t
0	1	0	1	ENQ	NAK	%	5	E	U	e	u
0	1	1	0	ACK	SYN	&	6	F	V	f	v
0	1	1	1	BEL	ETB	'	7	G	W	g	w
1	0	0	0	BS	CAN	(8	H	X	h	x
1	0	0	1	HT	EM)	9	I	Y	i	y
1	0	1	0	LF	SUB	*	:	J	Z	j	z
1	0	1	1	VT	ESC	+	;	K	[k	{
1	1	0	0	FF	FS	,	<	L	\	l	*
1	1	0	1	CR	GS	-	=	M]	m	}
1	1	1	0	SO	RS	.	>	N	^	n	~
1	1	1	1	SI	US	/	?	O	_	o	RUBOUT (DEL)

* | on some keyboards or systems

Table B-2
CHARACTERS USED IN < CHAR> PARAMETERS

BITS				CONTROL		FIGURES		UPPERCASE		LOWERCASE	
B7	B6	B5	B4	000	001	010	011	100	101	110	111
0	0	0	0	NUL 0	DLE 16	SP 32	0 48	@ 64	P 80	\ 96	p 112
0	0	0	1	SOH 1	DC1 17	! 33	1 49	A 65	Q 81	a 97	q 113
0	0	1	0	STX 2	DC2 18	" 34	2 50	B 66	R 82	b 98	r 114
0	0	1	1	ETX 3	DC3 19	# 35	3 51	C 67	S 83	c 99	s 115
0	1	0	0	EOT 4	DC4 20	\$ 36	4 52	D 68	T 84	d 100	t 116
0	1	0	1	ENQ 5	NAK 21	% 37	5 53	E 69	U 85	e 101	u 117
0	1	1	0	ACK 6	SYN 22	& 38	6 54	F 70	V 86	f 102	v 118
0	1	1	1	BEL 7	ETB 23	/ 39	7 55	G 71	W 87	g 103	w 119
1	0	0	0	BS 8	CAN 24	(40	8 56	H 72	X 88	h 104	x 120
1	0	0	1	HT 9	EM 25) 41	9 57	I 73	Y 89	i 105	y 121
1	0	1	0	LF 10	SUB 26	* 42	: 58	J 74	Z 90	j 106	z 122
1	0	1	1	VT 11	ESC 27	+ 43	; 59	K 75	[91	k 107	{ 123
1	1	0	0	FF 12	FS 28	, 44	< 60	L 76	\ 92	l 108	l* 124
1	1	0	1	CR 13	GS 29	- 45	= 61	M 77] 93	m 109	} 125
1	1	1	0	SO 14	RS 30	. 46	> 62	N 78	^ 94	n 110	~ 126
1	1	1	1	SI 15	US 31	/ 47	? 63	O 79	_ 95	o 111	RUBOUT (DEL) 127

* |
 | on some keyboards or systems

3818-87

Table B-3
CHARACTERS USED IN <INT> AND <INT+> PARAMETERS

<HiI> Characters

<LoI> Characters

BITS				0 0		0 1		1 0		1 1	
B7	B6	B5	B4	B3	B2	B1	B0	B3	B2	B1	B0
				CONTROL		FIGURES		UPPERCASE		LOWERCASE	
0	0	0	0	NUL	DLE	SP	0	@	P	\	p
0	0	0	1	SOH	DC1	!	1	A	Q	a	q
0	0	1	0	STX	DC2	"	2	B	R	b	r
0	0	1	1	ETX	DC3	#	3	C	S	c	s
0	1	0	0	EOT	DC4	\$	4	D	T	d	t
0	1	0	1	ENQ	NAK	%	5	E	U	e	u
0	1	1	0	ACK	SYN	&	6	F	V	f	v
0	1	1	1	BEL	ETB	'	7	G	W	g	w
1	0	0	0	BS	CAN	(8	H	X	h	x
1	0	0	1	HT	EM)	9	I	Y	i	y
1	0	1	0	LF	SUB	*	:	J	Z	j	z
1	0	1	1	VT	ESC	+	;	K	[k	{
1	1	0	0	FF	FS	,	<	L	\	l	l*
1	1	0	1	CR	GS	-	=	M]	m	}
1	1	1	0	SO	RS	.	>	N	^	n	~
1	1	1	1	SI	US	/	?	O	_	o	RUBOUT (DEL)

* 1 on some keyboards or systems

BITS				0 0		0 1		1 0		1 1	
B7	B6	B5	B4	B3	B2	B1	B0	B3	B2	B1	B0
				CONTROL		FIGURES		UPPERCASE		LOWERCASE	
0	0	0	0	NUL	DLE	SP	0	@	P	\	p
0	0	0	1	SOH	DC1	!	1	A	Q	a	q
0	0	1	0	STX	DC2	"	2	B	R	b	r
0	0	1	1	ETX	DC3	#	3	C	S	c	s
0	1	0	0	EOT	DC4	\$	4	D	T	d	t
0	1	0	1	ENQ	NAK	%	5	E	U	e	u
0	1	1	0	ACK	SYN	&	6	F	V	f	v
0	1	1	1	BEL	ETB	'	7	G	W	g	w
1	0	0	0	BS	CAN	(8	H	X	h	x
1	0	0	1	HT	EM)	9	I	Y	i	y
1	0	1	0	LF	SUB	*	:	J	Z	j	z
1	0	1	1	VT	ESC	+	;	K	[k	{
1	1	0	0	FF	FS	,	<	L	\	l	l*
1	1	0	1	CR	GS	-	=	M]	m	}
1	1	1	0	SO	RS	.	>	N	^	n	~
1	1	1	1	SI	US	/	?	O	_	o	RUBOUT (DEL)

Table B-4
CHARACTERS USED IN <INT-REPORT> PARAMETERS

<Hil-Report> Characters

BITS		0 0		0 1		1 0		1 1	
B4	B3 B2 B1	CONTROL		FIGURES		UPPERCASE		LOWERCASE	
0	0 0 0	NUL	DLE	SP	0	@	P	\	p
0	0 0 1	SOH	DC1	!	1	A	Q	a	q
0	0 1 0	STX	DC2	"	2	B	R	b	r
0	0 1 1	ETX	DC3	#	3	C	S	c	s
0	1 0 0	EOT	DC4	\$	4	D	T	d	t
0	1 0 1	ENQ	NAK	%	5	E	U	e	u
0	1 1 0	ACK	SYN	&	6	F	V	f	v
0	1 1 1	BEL	ETB	/	7	G	W	g	w
1	0 0 0	BS	CAN	(8	H	X	h	x
1	0 0 1	HT	EM)	9	I	Y	i	y
1	0 1 0	LF	SUB	*	:	J	Z	j	z
1	0 1 1	VT	ESC	+	;	K	[k	{
1	1 0 0	FF	FS	,	<	L	\	l	*
1	1 0 1	CR	GS	-	=	M]	m	}
1	1 1 0	SO	RS	.	>	N	^	n	~
1	1 1 1	SI	US	/	?	O	_	o	RUBOUT (DEL)

* | on some keyboards or systems

<Lol-Report> Characters

BITS		0 0		0 1		1 0		1 1	
B4	B3 B2 B1	CONTROL		FIGURES		UPPERCASE		LOWERCASE	
0	0 0 0	NUL	DLE	SP	0	@	P	\	p
0	0 0 1	SOH	DC1	!	1	A	Q	a	q
0	0 1 0	STX	DC2	"	2	B	R	b	r
0	0 1 1	ETX	DC3	#	3	C	S	c	s
0	1 0 0	EOT	DC4	\$	4	D	T	d	t
0	1 0 1	ENQ	NAK	%	5	E	U	e	u
0	1 1 0	ACK	SYN	&	6	F	V	f	v
0	1 1 1	BEL	ETB	/	7	G	W	g	w
1	0 0 0	BS	CAN	(8	H	X	h	x
1	0 0 1	HT	EM)	9	I	Y	i	y
1	0 1 0	LF	SUB	*	:	J	Z	j	z
1	0 1 1	VT	ESC	+	;	K	[k	{
1	1 0 0	FF	FS	,	<	L	\	l	*
1	1 0 1	CR	GS	-	=	M]	m	}
1	1 1 0	SO	RS	.	>	N	^	n	~
1	1 1 1	SI	US	/	?	O	_	o	RUBOUT (DEL)

Table B-5
CHARACTERS USED IN <XY> PARAMETERS

<HIY>, <HIX> Characters

BITS		CONTROL		FIGURES		UPPERCASE		LOWERCASE			
87	86	00	00	01	01	10	10	11	11		
84	83	82	81								
0	0	0	NUL	DLE	SP	0	@	P	\	p	
0	0	0	1	SOH	DC1	!	1	A	Q	a	q
0	0	1	0	STX	DC2	"	2	B	R	b	r
0	0	1	1	ETX	DC3	#	3	C	S	c	s
0	1	0	0	EOT	DC4	\$	4	D	T	d	t
0	1	0	1	ENQ	NAK	%	5	E	U	e	u
0	1	1	0	ACK	SYN	&	6	F	V	f	v
0	1	1	1	BEL	ETB	'	7	G	W	g	w
1	0	0	0	BS	CAN	(8	H	X	h	x
1	0	0	1	HT	EM)	9	I	Y	i	y
1	0	1	0	LF	SUB	*	:	J	Z	j	z
1	0	1	1	VT	ESC	+	;	K	[k	{
1	1	0	0	FF	FS	,	<	L	\	l	
1	1	0	1	CR	GS	-	=	M]	m	}
1	1	1	0	SO	RS	.	>	N	^	n	~
1	1	1	1	SI	US	/	?	O	-	o	-

<LoY>, <Extra> Characters

BITS		CONTROL		FIGURES		UPPERCASE		LOWERCASE			
87	86	00	00	01	01	10	10	11	11		
84	83	82	81								
0	0	0	NUL	DLE	SP	0	@	P	\	p	
0	0	0	1	SOH	DC1	!	1	A	Q	a	q
0	0	1	0	STX	DC2	"	2	B	R	b	r
0	0	1	1	ETX	DC3	#	3	C	S	c	s
0	1	0	0	EOT	DC4	\$	4	D	T	d	t
0	1	0	1	ENQ	NAK	%	5	E	U	e	u
0	1	1	0	ACK	SYN	&	6	F	V	f	v
0	1	1	1	BEL	ETB	'	7	G	W	g	w
1	0	0	0	BS	CAN	(8	H	X	h	x
1	0	0	1	HT	EM)	9	I	Y	i	y
1	0	1	0	LF	SUB	*	:	J	Z	j	z
1	0	1	1	VT	ESC	+	;	K	[k	{
1	1	0	0	FF	FS	,	<	L	\	l	
1	1	0	1	CR	GS	-	=	M]	m	}
1	1	1	0	SO	RS	.	>	N	^	n	~
1	1	1	1	SI	US	/	?	O	-	o	RUBOUT (DEL)

<LoX> Characters

BITS		CONTROL		FIGURES		UPPERCASE		LOWERCASE			
87	86	00	00	01	01	10	10	11	11		
84	83	82	81								
0	0	0	NUL	DLE	SP	0	@	P	\	p	
0	0	0	1	SOH	DC1	!	1	A	Q	a	q
0	0	1	0	STX	DC2	"	2	B	R	b	r
0	0	1	1	ETX	DC3	#	3	C	S	c	s
0	1	0	0	EOT	DC4	\$	4	D	T	d	t
0	1	0	1	ENQ	NAK	%	5	E	U	e	u
0	1	1	0	ACK	SYN	&	6	F	V	f	v
0	1	1	1	BEL	ETB	'	7	G	W	g	w
1	0	0	0	BS	CAN	(8	H	X	h	x
1	0	0	1	HT	EM)	9	I	Y	i	y
1	0	1	0	LF	SUB	*	:	J	Z	j	z
1	0	1	1	VT	ESC	+	;	K	[k	{
1	1	0	0	FF	FS	,	<	L	\	l	
1	1	0	1	CR	GS	-	=	M]	m	}
1	1	1	0	SO	RS	.	>	N	^	n	~
1	1	1	1	SI	US	/	?	O	-	o	RUBOUT (DEL)

* 1 on some keyboards or systems

Table B-6
CHARACTERS USED IN <XY-REPORT> PARAMETERS

BITS				0 0		0 1		1 0		1 1					
B7	B6	B5	B4	B3	B2	B1	CONTROL		FIGURES		UPPERCASE		LOWERCASE		
0	0	0	0	0	0	0	0	1	0	1	0	1	1	1	1
0	0	0	0	NUL	DLE	SP	0	@	P	\	p				
0	0	0	1	SOH	DC1	!	1	A	Q	a	q				
0	0	1	0	STX	DC2	"	2	B	R	b	r				
0	0	1	1	ETX	DC3	#	3	C	S	c	s				
0	1	0	0	EOT	DC4	\$	4	D	T	d	t				
0	1	0	1	ENQ	NAK	%	5	E	U	e	u				
0	1	1	0	ACK	SYN	&	6	F	V	f	v				
0	1	1	1	BEL	ETB	/	7	G	W	g	w				
1	0	0	0	BS	CAN	(8	H	X	h	x				
1	0	0	1	HT	EM)	9	I	Y	i	y				
1	0	1	0	LF	SUB	*	:	J	Z	j	z				
1	0	1	1	VT	ESC	+	;	K	[k	{				
1	1	0	0	FF	FS	,	<	L	\	l	l*				
1	1	0	1	CR	GS	-	=	M]	m	}				
1	1	1	0	SO	RS	.	>	N	^	n	~				
1	1	1	1	SI	US	/	?	O	_	o	RUBOUT (DEL)				

* |
 | on some keyboards or systems

3818-91

Table B-7
UNITED KINGDOM CHARACTER SET

BITS				CONTROL		HIGH X & Y GRAPHIC INPUT		LOW X		LOW Y		
B7	B6	B5	B4	B3	B2	B1						
0	0	0	0	0	0	1	0	0	1	0	0	
0	0	0	1	0	0	1	0	0	1	0	0	
0	0	1	0	0	0	1	0	0	1	0	0	
0	0	1	1	0	0	1	0	0	1	0	0	
0	0	1	1	1	0	0	1	0	0	1	0	
0	0	1	1	1	1	0	0	1	0	0	0	
0	1	0	0	0	0	1	0	0	1	0	0	
0	1	0	0	1	0	0	1	0	0	1	0	
0	1	0	1	0	0	1	0	0	1	0	0	
0	1	0	1	1	0	0	1	0	0	1	0	
0	1	0	1	1	1	0	0	1	0	0	0	
0	1	1	0	0	0	1	0	0	1	0	0	
0	1	1	0	0	1	0	0	1	0	0	0	
0	1	1	0	1	0	0	1	0	0	1	0	
0	1	1	0	1	1	0	0	1	0	0	0	
0	1	1	1	0	0	1	0	0	1	0	0	
0	1	1	1	0	1	0	0	1	0	0	0	
0	1	1	1	1	0	0	1	0	0	1	0	
0	1	1	1	1	1	0	0	1	0	0	0	
0	1	1	1	1	1	1	0	0	1	0	0	
0	1	1	1	1	1	1	1	0	0	1	0	
0	1	1	1	1	1	1	1	1	0	0	0	
0	1	1	1	1	1	1	1	1	1	0	0	
0	1	1	1	1	1	1	1	1	1	1	0	
0	1	1	1	1	1	1	1	1	1	1	1	
0	0	0	0		NUL	DLE	SP	0	@	P	\	p
				0	0	16	32	48	64	80	96	112
0	0	0	1		SOH	DC1	!	1	A	Q	a	q
				1	17	33	49	65	81	97	113	
0	0	1	0		STX	DC2	"	2	B	R	b	r
				2	18	34	50	66	82	98	114	
0	0	1	1		ETX	DC3	£	3	C	S	c	s
				3	19	35	51	67	83	99	115	
0	1	0	0		EOT	DC4	\$	4	D	T	d	t
				4	20	36	52	68	84	100	116	
0	1	0	1		ENQ	NAK	%	5	E	U	e	u
				5	21	37	53	69	85	101	117	
0	1	1	0		ACK	SYN	&	6	F	V	f	v
				6	22	38	54	70	86	102	118	
0	1	1	1		BEL	ETB	/	7	G	W	g	w
				BELL	7	23	39	55	71	87	103	119
1	0	0	0		BS	CAN	(8	H	X	h	x
				BACK-SPACE	8	24	40	56	72	88	104	120
1	0	0	1		HT	EM)	9	I	Y	i	y
				9	25	41	57	73	89	105	121	
1	0	1	0		LF	SUB	*	:	J	Z	j	z
				10	26	42	58	74	90	106	122	
1	0	1	1		VT	ESC	+	;	K	[k	{
				11	27	43	59	75	91	107	123	
1	1	0	0		FF	FS	,	<	L	\	l	l*
				12	28	44	60	76	92	108	124	
1	1	0	1		CR	GS	-	=	M]	m	}
				RETURN	13	29	45	61	77	93	109	125
1	1	1	0		SO	RS	.	>	N	^	n	~
				14	30	46	62	78	94	110	126	
1	1	1	1		SI	US	/	?	O	-	o	RUBOUT (DEL)
				15	31	47	63	79	95	111	127	

3673-51

Table B-8
SWEDISH CHARACTER SET

BITS				0 0		0 0 1		0 1 0		0 1 1		1 0 0		1 0 1		1 1 0		1 1 1	
B7	B6	B5		CONTROL				HIGH X & Y GRAPHIC INPUT				LOW X				LOW Y			
B4	B3	B2	B1																
0	0	0	0	NUL 0	DLE 16	SP 32	0 48	@ 64	P 80	\ 96	p 112								
0	0	0	1	SOH 1	DC1 17	! 33	1 49	A 65	Q 81	a 97	q 113								
0	0	1	0	STX 2	DC2 18	" 34	2 50	B 66	R 82	b 98	r 114								
0	0	1	1	ETX 3	DC3 19	# 35	3 51	C 67	S 83	c 99	s 115								
0	1	0	0	EOT 4	DC4 20	\$ 36	4 52	D 68	T 84	d 100	t 116								
0	1	0	1	ENQ 5	NAK 21	% 37	5 53	E 69	U 85	e 101	u 117								
0	1	1	0	ACK 6	SYN 22	& 38	6 54	F 70	V 86	f 102	v 118								
0	1	1	1	BEL BELL 7	ETB 23	/ 39	7 55	G 71	W 87	g 103	w 119								
1	0	0	0	BS BACK-SPACE 8	CAN 24	(40	8 56	H 72	X 88	h 104	x 120								
1	0	0	1	HT 9	EM 25) 41	9 57	I 73	Y 89	i 105	y 121								
1	0	1	0	LF 10	SUB 26	* 42	: 58	J 74	Z 90	j 106	z 122								
1	0	1	1	VT 11	ESC 27	+ 43	; 59	K 75	Ä 91	k 107	ä 123								
1	1	0	0	FF 12	FS 28	, 44	< 60	L 76	Ö 92	l 108	ö 124								
1	1	0	1	CR RETURN 13	GS 29	- 45	= 61	M 77	Å 93	m 109	å 125								
1	1	1	0	SO 14	RS 30	. 46	> 62	N 78	^ 94	n 110	~ 126								
1	1	1	1	SI 15	US 31	/ 47	? 63	O 79	_ 95	o 111	RUBOUT (DEL) 127								

3673-52

Table B-9
APL CHARACTER SET

BITS				CONTROL		HIGH X & Y GRAPHIC INPUT		LOW X		LOW Y				
B7	B6	B5	B4	B3	B2	B1	000	001	010	011	100	101	110	111
0	0	0	0	NUL 0	DLE 16	SP 32	0 48	- 64	* 80	◇ 96	P 112			
0	0	0	1	SOH 1	DC1 17	¨ 33	1 49	α 65	? 81	A 97	Q 113			
0	0	1	0	STX 2	DC2 18) 34	2 50	⊥ 66	ρ 82	B 98	R 114			
0	0	1	1	ETX 3	DC3 19	< 35	3 51	∩ 67	Γ 83	C 99	S 115			
0	1	0	0	EOT 4	DC4 20	≤ 36	4 52	L 68	~ 84	D 100	T 116			
0	1	0	1	ENQ 5	NAK 21	= 37	5 53	€ 69	↓ 85	E 101	U 117			
0	1	1	0	ACK 6	SYN 22	> 38	6 54	- 70	U 86	F 102	V 118			
0	1	1	1	BEL BELL 7	ETB 23] 39	7 55	∇ 71	ω 87	G 103	W 119			
1	0	0	0	BS BACK-SPACE 8	CAN 24	v 40	8 56	Δ 72	∃ 88	H 104	X 120			
1	0	0	1	HT 9	EM 25	^ 41	9 57	ı 73	↑ 89	I 105	Y 121			
1	0	1	0	LF 10	SUB 26	≠ 42	(58	◦ 74	∩ 90	J 106	Z 122			
1	0	1	1	VT 11	ESC 27	÷ 43	[59	' 75	← 91	K 107	{ 123			
1	1	0	0	FF 12	FS 28	, 44	; 60	□ 76	⊥ 92	L 108	¬ 124			
1	1	0	1	CR RETURN 13	GS 29	+ 45	× 61	 77	→ 93	M 109	} 125			
1	1	1	0	SO 14	RS 30	. 46	: 62	T 78	≥ 94	N 110	\$ 126			
1	1	1	1	SI 15	US 31	/ 47	\ 63	o 79	- 95	O 111	RUBOUT (DEL) 127			

3673-54

Table B-10
DANISH/NORWEGIAN CHARACTER SET

BITS				CONTROL		HIGH X & Y GRAPHIC INPUT		LOW X		LOW Y				
B7	B6	B5	B4	B3	B2	B1								
0	0	0	0	0	0	0	NUL	DLE	SP	0	@	P	\	p
							0	16	32	48	64	80	96	112
0	0	0	1	0	0	0	SOH	DC1	!	1	A	Q	a	q
							1	17	33	49	65	81	97	113
0	0	1	0	0	0	0	STX	DC2	"	2	B	R	b	r
							2	18	34	50	66	82	98	114
0	0	1	1	0	0	0	ETX	DC3	#	3	C	S	c	s
							3	19	35	51	67	83	99	115
0	1	0	0	0	0	0	EOT	DC4	\$	4	D	T	d	t
							4	20	36	52	68	84	100	116
0	1	0	1	0	0	0	ENQ	NAK	%	5	E	U	e	u
							5	21	37	53	69	85	101	117
0	1	1	0	0	0	0	ACK	SYN	&	6	F	V	f	v
							6	22	38	54	70	86	102	118
0	1	1	1	0	0	0	BEL	ETB	/	7	G	W	g	w
							BELL 7	23	39	55	71	87	103	119
1	0	0	0	0	0	0	BS	CAN	(8	H	X	h	x
							BACK-SPACE 8	24	40	56	72	88	104	120
1	0	0	1	0	0	0	HT	EM)	9	I	Y	i	y
							9	25	41	57	73	89	105	121
1	0	1	0	0	0	0	LF	SUB	*	:	J	Z	j	z
							10	26	42	58	74	90	106	122
1	0	1	1	0	0	0	VT	ESC	+	;	K	Æ	k	æ
							11	27	43	59	75	91	107	123
1	1	0	0	0	0	0	FF	FS	,	<	L	Ø	l	ø
							12	28	44	60	76	92	108	124
1	1	0	1	0	0	0	CR	GS	-	=	M	Å	m	å
							RETURN 13	29	45	61	77	93	109	125
1	1	1	0	0	0	0	SO	RS	.	>	N	^	n	~
							14	30	46	62	78	94	110	126
1	1	1	1	0	0	0	SI	US	/	?	O	-	o	RUBOUT (DEL)
							15	31	47	63	79	95	111	127

3673-55

