

# 3WP- CATHODE-RAY TUBES

The Type 3WP- Cathode-ray Tubes are designed for applications where tight tolerances and high sensitivity are important. Among the important features of this line of industrial tubes are: reduction by 50% in critical tolerances for deflection sensitivity and grid cutoff; improved perpendicularity with angle alignment between "X" and "Y" deflection plates held to  $90^\circ \pm 1^\circ$ ; greatly improved sensitivity on both axes without reduction in useful scan and a flat face to reduce parallax error.

The inherently higher sensitivity of this line of "Tight-tolerance" cathode-ray tubes, such as the Type 3WP-, over previously available commercial tubes permits smaller, lower cost amplifiers, while tight tolerances afford greater freedom in cathode-ray equipment design.



## GENERAL CHARACTERISTICS

### Electrical

Heater Voltage .....	6.3 Volts
Heater Current .....	$0.6 \pm 10\%$ Ampere
Focusing Method .....	Electrostatic
Deflecting Method .....	Electrostatic

Phosphor	P1	P11
Fluorescence	Green	Blue
Persistence	Medium	Short

Direct Interelectrode Capacitances		
	Min.	Max.
Cathode to all other electrodes	3.0	5.7 $\mu\mu\text{f.}$
Grid No. 1 to all other electrodes	4.6	8.7 $\mu\mu\text{f.}$
D1 to D2	1.7	3.3 $\mu\mu\text{f.}$
D3 to D4	1.0	2.0 $\mu\mu\text{f.}$
D1 to all other electrodes except D2	3.8	7.2 $\mu\mu\text{f.}$
D2 to all other electrodes except D1	3.8	7.2 $\mu\mu\text{f.}$
D3 to all other electrodes except D4	2.5	4.8 $\mu\mu\text{f.}$
D4 to all other electrodes except D3	2.5	4.8 $\mu\mu\text{f.}$

### Mechanical

Overall Length .....	$11\frac{1}{2} \pm \frac{1}{8}$ Inches
Greatest Diameter of Bulb .....	$3 \pm \frac{1}{16}$ Inches
Minimum Useful Screen Diameter .....	$2\frac{3}{4}$ Inches
Base (Small Shell 12-pin Duodecal) .....	B12-43
Basing .....	12T

Base Alignment	
D1D2 trace aligns with Pin No. 3 and tube axis .....	$\pm 10$ Degrees
Positive voltage on D1 deflects beam approximately toward Pin No. 3	
Positive voltage on D3 deflects beam approximately toward Pin No. 12	
Angle between D3D4 and D1D2 traces .....	$90 \pm 1$ Degrees

## MAXIMUM RATINGS—(Design Center Values)

Accelerator Voltage <sup>1</sup> .....	2,500 Max. Volts D-C
Focusing Voltage .....	1,000 Max. Volts D-C
Grid No. 1 Voltage	
Negative Bias Value .....	200 Max. Volts D-C
Positive Bias Value .....	0 Max. Volts D-C
Positive Peak Value .....	0 Max. Volts
Peak Heater-Cathode Voltage	
Heater Negative with respect to Cathode .....	180 Max. Volts D-C
Heater Positive with respect to Cathode .....	180 Max. Volts D-C
Peak Voltage between Accelerator and any Deflection Electrode .....	500 Max. Volts

## TYPICAL OPERATING CONDITIONS

For Accelerator Voltage of .....	1,500 Volts
Focusing Voltage .....	247 to 465 Volts
Grid No. 1 Voltage <sup>2</sup> .....	-45 to -75 Volts
Modulation <sup>3</sup> .....	50 Volts Max.
Line Width A <sup>3</sup> .....	.026 Inch Max.
P1 Light Output <sup>3</sup> .....	7 Ft. L. Min.
Deflection Factors:	
D1D2 .....	62 to 76 Volts D-C per Inch
D3D4 .....	43 to 52 Volts D-C per Inch
Deflection Factor Uniformity <sup>4</sup> .....	2% Maximum
Useful Scan	
D1D2 .....	2.50 Inches*
D3D4 .....	2.25 Inches**
Pattern Distortion at 90% of Useful Scan <sup>5</sup> .....	2% Max.
Spot Position (Undelected) .....	Within a 3/16-inch radius circle <sup>7</sup>

## CIRCUIT DESIGN VALUES

Focusing Voltage .....	165 to 310 Volts per Kilovolt of Accelerator Voltage
Focusing Current for any operating condition .....	-15 to +10 Microamperes
Grid No. 1 Voltage <sup>2</sup> .....	30 to 50 Volts per Kilovolt of Accelerator Voltage
Grid No. 1 Circuit Resistance .....	1.5 Max. Megohms
Deflection Factors	
D1 and D2 .....	41.5 to 50.5 Volts D-C/Inch/KV of Accelerator Voltage
D3 and D4 .....	28.5 to 35.0 Volts D-C/Inch/KV of Accelerator Voltage
Resistance in any Deflecting-Electrode Circuit <sup>8</sup> .....	5 Max. Megohms

\*  $\pm 1.25''$  minimum from tube face center

\*\*  $\pm 1.125''$  minimum from tube face center

## NOTES

1. The product of Accelerator voltage and average Accelerator current should be limited to 6 watts.
2. Visual extinction of undeflected focused spot.
3. Measured in accordance with MIL-E-1 specifications.
4. The deflection factor (for both D1D2 and D3D4 plate pairs, separately) for a deflection of less than 75% of the useful scan will not differ from the deflection factor for a deflection at 25% of the useful scan by more than the indicated value.
5. All portions of a raster pattern, adjusted so its widest points just touch the sides of a 2.295 x 2.065-inch rectangle, will fall within the area bounded by the 2.295 x 2.065-inch rectangle and an inscribed 2.205 x 1.985-inch rectangle.
6. Deflection accuracy may be obtained by combining angle between traces, deflection factor uniformity and pattern distortion characteristics. In general, for deflections less than those indicated the accuracy will improve.
7. When the tube is operated at typical operating conditions ( $E_h = 6.3$  V.,  $E_{b2} = 1500$  V.,  $E_{b1}$  at focus);  $E_{c1}$  adjusted to avoid damage to the screen; with each of the deflecting electrodes connected to the accelerator; and with the tube shielded against external influences, the spot will fall within a 3/16-inch radius circle centered on the tube face.
8. It is recommended that the deflecting electrode circuit resistances be approximately equal.
9. For optimum focus the average potentials of the deflection plates and second anode should be the same.

3WP-  
AVERAGE CHARACTERISTICS

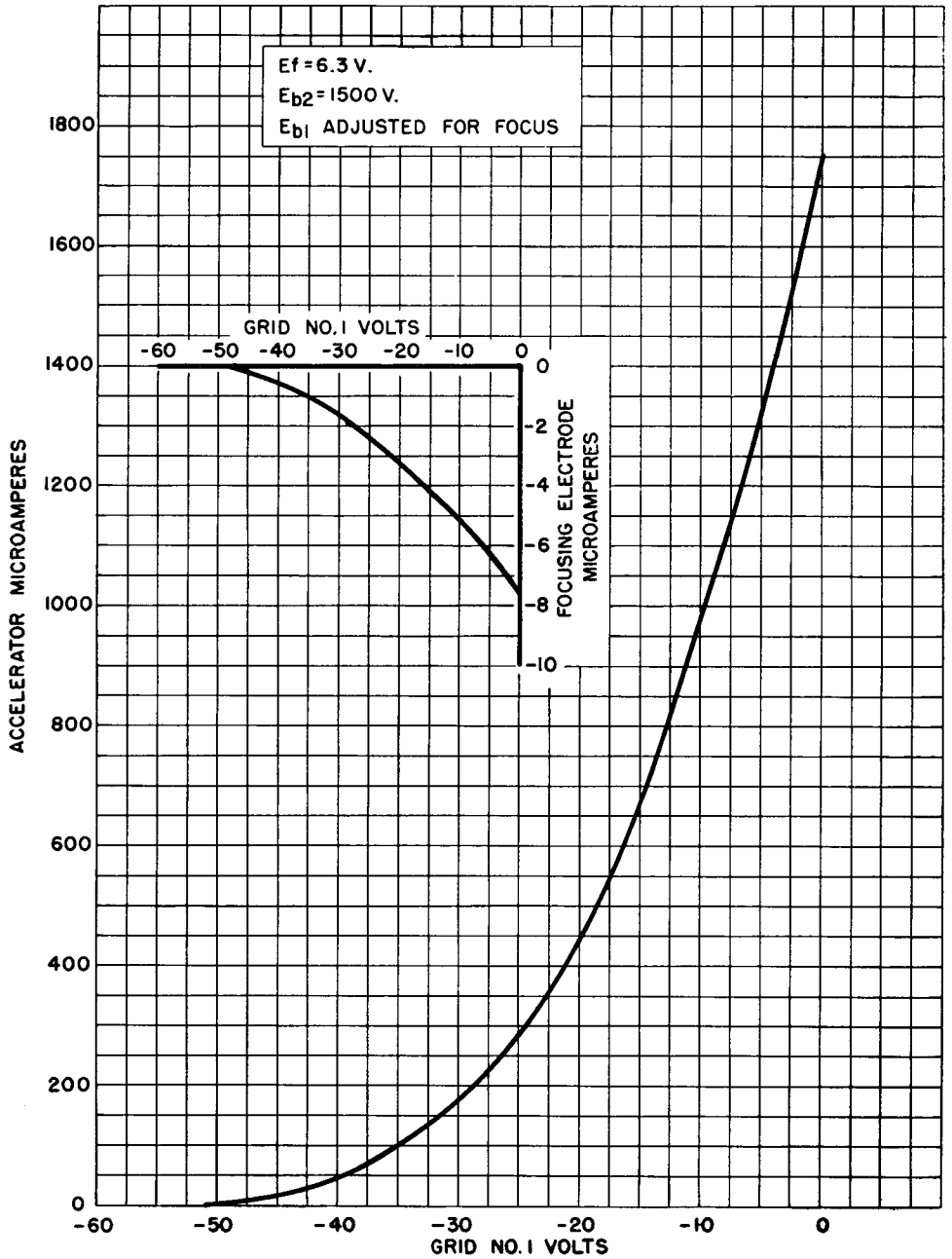

TYPE 3WP-

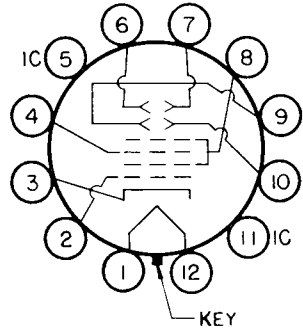
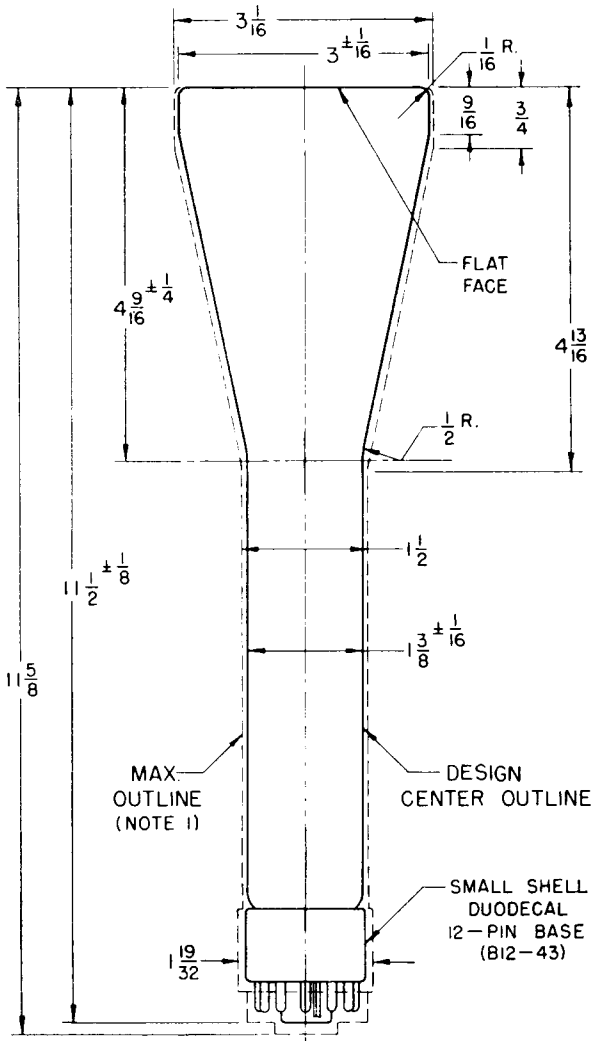

BOTTOM VIEW OF BASE

PIN NO. ELEMENT

- 1 — HEATER
- 2 — GRID NO. 1
- 3 — CATHODE
- 4 — FOCUSING ELECTRODE
- 5 — INTERNAL CONNECTION
- 6 — DEFLECTING ELECTRODE  $D_1$
- 7 — DEFLECTING ELECTRODE  $D_2$
- 8 — ACCELERATOR
- 9 — DEFLECTING ELECTRODE  $D_4$
- 10 — DEFLECTING ELECTRODE  $D_3$
- 11 — INTERNAL CONNECTION
- 12 — HEATER

NOTE:

1—NO TUBE WILL EXCEED MAXIMUM OUTLINE.