

**050-3109-XX**  
**A6302 Current Probe**  
**Cable Assembly Replacement Kit**  
**Instructions**

[www.tektronix.com](http://www.tektronix.com)



075-1008-00

**Tektronix**

Copyright © Tektronix. All rights reserved. Licensed software products are owned by Tektronix or its subsidiaries or suppliers, and are protected by national copyright laws and international treaty provisions.

Tektronix products are covered by U.S. and foreign patents, issued and pending. Information in this publication supersedes that in all previously published material. Specifications and price change privileges reserved.

TEKTRONIX and TEK are registered trademarks of Tektronix, Inc.

## **Contacting Tektronix**

Tektronix, Inc.  
14200 SW Karl Braun Drive  
P.O. Box 500  
Beaverton, OR 97077  
USA

For product information, sales, service, and technical support:

- In North America, call 1-800-833-9200.
- Worldwide, visit [www.tektronix.com](http://www.tektronix.com) to find contacts in your area.

# Kit Description

This kit includes parts and instructions to replace the existing cable assembly of the A6302 Current Probe. The new cable assembly includes a new circuit board and requires an additional ground connection to the lower body half of the probe head.

This document supports Tektronix mods: ECR 32847

## Instruments

**A6302** Serial numbers B010100 through B064999

## Minimum Tool and Equipment List

Tool	Description
Screwdriver	Small Pozidrive
Desoldering tool	Solder vacuum
Solder iron	Pencil type 20-25 Watt
Solder	Rosin-core, electronic-grade, 60/40

## Kit Parts List

Quantity	Part number	Description
1 ea	175-1836-XX	Cable Assy: Cable & Circuit Board; A6302
1 ea	120-0464-XX	Transformer, Cur; Upper & Lower, A6302
1 ea	204-0714-XX	Body Half, Probe, Lower, W/Contacts; A6302, Safety controlled
1 ea	196-3428-XX	Wire, Insulated: 30 AWG, BLK,1.200, cut & stripped both ends
1 ea	—————	Label: 050-kit, A6302
1 ea	070-3905-XX	Manual, Tech: Instructions, A6302, A6302XL
1 ea	075-1008-XX	Kit Instructions, A6302 Cable Assembly Replacement

## Service Safety Summary

Only qualified personnel should perform service procedures. Read this Service Safety Summary before performing any service procedures.

**Disconnect Power** Before disassembling the probe, remove power to the probe by disconnecting the probe from the measurement instrument.

## Installation Instructions

These instructions assume a certain familiarity with the instrument. If further details are required for disassembly or assembly, refer to the A6302 & A6302XL Instructions. For assistance installing this kit, please call your nearest Tektronix, Inc., Service Center or Tektronix Factory Service.

### Disassemble the Probe Body

Use the following procedure to disassemble the probe body:



**WARNING.** Probe disassembly should only be performed by qualified service personnel.

---

1. Remove the two screws from the bottom of the probe and pull back the strain relief boot. (See Figure 1.)

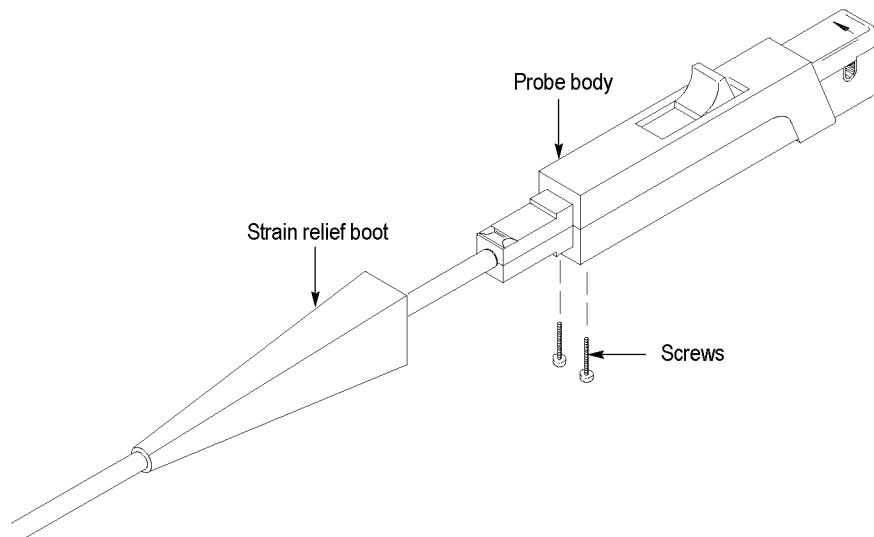

Figure 1: Removing the strain relief boot

2. Move the probe slide assembly to the open position.

---

**NOTE.** *The probe slide contains a tiny metal ball. In step 3, be careful not to lose the ball by accidentally letting it fall out.*

---

3. Hold the probe in a top-up horizontal position and slide the top half of the probe body off. (See Figure 2.)

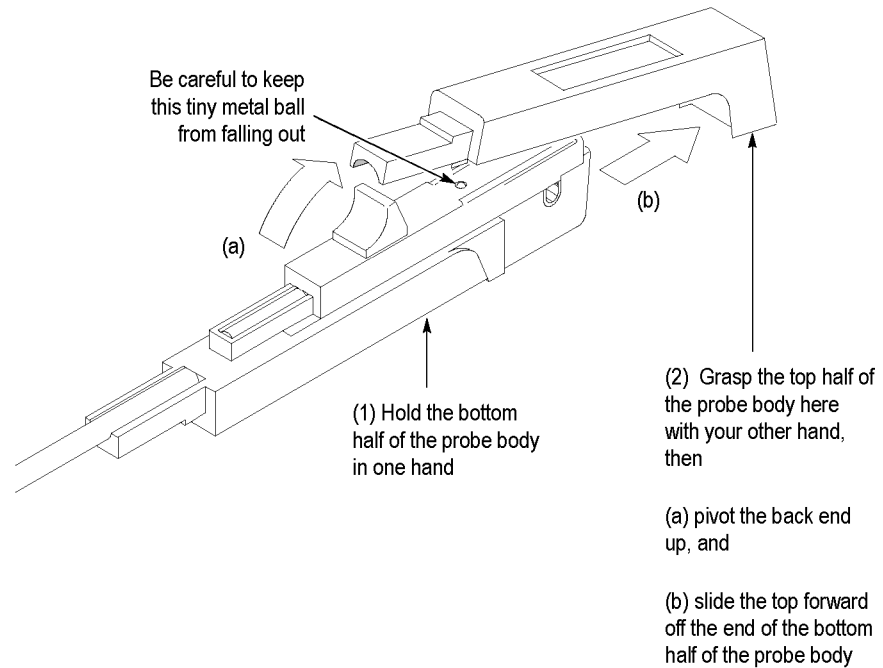

**Figure 2: Removing the top half of the probe**

4. Remove the metal ball.

5. Turn the probe upside down, push the slide back slightly, and remove the slide. (See Figure 3.)

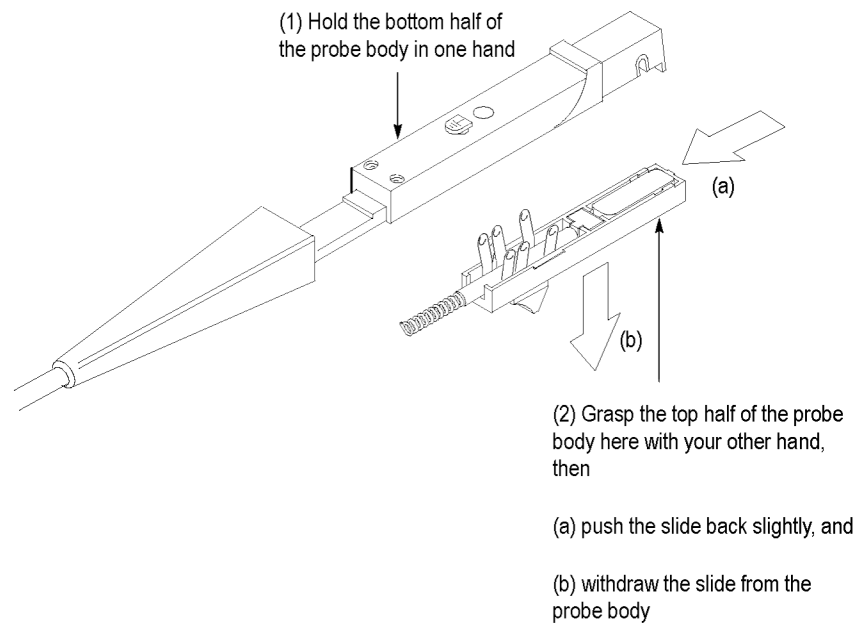
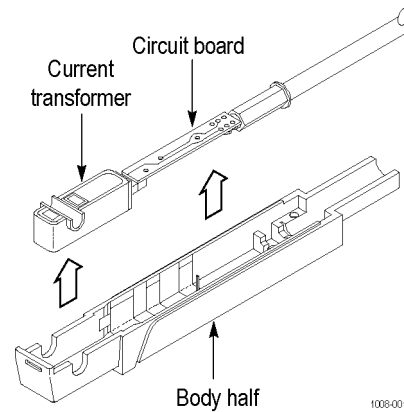

**Figure 3: Removing the probe slide**

## Remove the Current Transformer and the Cable Assembly

Remove the current transformer and the cable assembly as follows:

1. The circuit board may be soldered to a ground post attached to the body half. If necessary, carefully desolder the connection before attempting to remove the circuit board.
2. Remove the transformer and the circuit board by lifting the entire assembly out of the probe as shown. (See Figure 4.)



**Figure 4: Removing the current transformer and circuit board**

3. Pull the transformer off the connector pins on the circuit board as shown. (See Figure 5.)

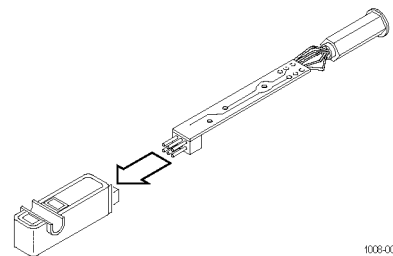
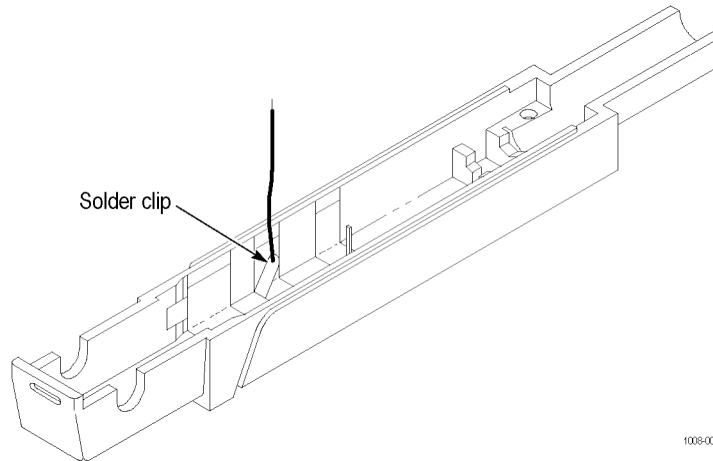

**Figure 5: Separating the current transformer from the circuit board**

## Installing the Black Wire and New Cable Assembly

Install the new black wire, cable assembly, and lower probe body half as follows:

1. Position the new lower probe body half from the kit on a stable surface, or secure the new probe body half with a bench vise.
2. Bend the solder clip up as shown and solder the new black wire to the clip. (See Figure 6.) It is important to bend the clip back down so that it will not short to the circuit board.



1008-003

**Figure 6: Installing the black wire**

3. Solder the other end of the black wire into the forward hole on the circuit board of the new cable assembly. (See Figure 7 on page 7.)
4. Plug the new transformer onto the pins of the cable assembly.



- Place the transformer and the circuit board into the body of the probe as shown, while carefully dressing the black wire and rear connector wires into the body. (See Figure 7.)



**CAUTION.** Carefully dress the wires in the lower body half to avoid damaging the wires inside the probe, and to avoid contact with the slide assembly.

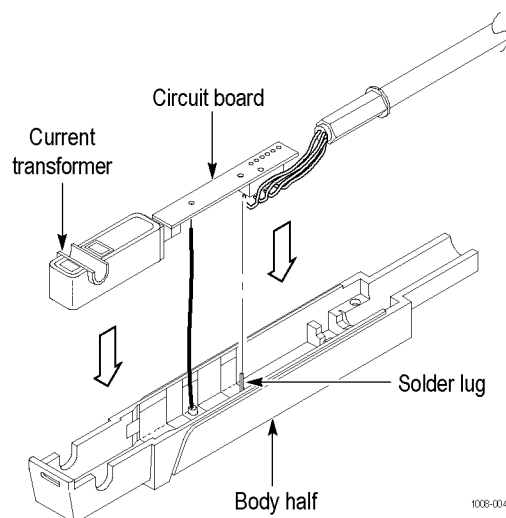

**Figure 7: Installing the current transformer and circuit board**

- Position the solder lug of the body half in the rear hole of the circuit board and solder the lug.
- Before reassembling the probe body, be sure that the gap between the stationary and moveable core pieces is clean. If necessary, use isopropyl alcohol or a similar cleaning agent to clean the pieces. Also, clean the contacts of the slide switch, if necessary. Should the plastic slide assembly require lubrication, sparingly apply silicone-based grease to the parts.

**NOTE.** Exercise care when fitting the slide back into the probe body; aligning the switch contacts can require patience.

## Reassemble the Probe Body

- Reassemble the probe body. Refer to the instructions for disassembling the probe body and perform the steps in reverse order. (See page 2, *Disassemble the Probe Body.*) Make sure the slide assembly does not come in contact with the wires in the lower body half.
- Add the 050-kit label to the side of the probe body.

## Verify Operation

Connect the probe to one of the compatible amplifiers listed in the instruction manual and perform a degauss/autobalance on the probe. If you need to confirm that the probe meets warranted specifications, use the performance verification procedures listed in the manual.

Note that some probe/amplifier combinations must be kept together as a system to preserve the calibrated specifications. If you calibrate the probe on an AM503 or AM503A amplifier and then interchange the probe with another amplifier or system, the specifications cannot be guaranteed. (See Table 1.)

**Table 1: A6302 Probe interchangeability after calibration**

<b>Amplifier</b>	<b>Interchangeable?</b>
AM503	No – keep together as a system
AM503A	No – keep together as a system
AM503B	Yes – only with another AM503B or an AM5030
AM5030	Yes – only with another AM5030 or an AM503B