



CRT DATA

T5360

Revision A

1-15-65

DESCRIPTION

The T5360 is a 5-inch, flat-faced cathode-ray tube designed for oscilloscope use. The T5360 has electrostatic focus and deflection, and a helical post accelerator.

ELECTRICAL DATA

Focusing method	Electrostatic
Deflecting method	Electrostatic
Direct interelectrode capacitance, approximate:	
Cathode to all other electrodes	4.8 pf
Grid no. 1 to all other electrodes	11.0 pf
D1 to D2	2.4 pf
D3 to D4	1.7 pf
D1 to all other electrodes	6.0 pf
D2 to all other electrodes	5.7 pf
D3 to all other electrodes	5.2 pf
D4 to all other electrodes	4.6 pf
Post-accelerator helix resistance	200 M Ω min

MECHANICAL DATA

Overall length	17-1/8 \pm 3/16 inches
Greatest bulb diameter	5-1/4 \pm 1/16 inches
Minimum useful screen diameter	4-1/2 inches
Bulb number	J42K
Bulb contact	J1-21
Base	B14-38
Basing	14 AF
Bulb contact alignment:	
J1-21 contact aligns with trace of D1-D2	\pm 5 $^\circ$
J1-21 contact on same side as pin no. 4	
Base alignment:	
Pin no. 1 aligns with D3-D4 trace	\pm 10 $^\circ$
Positive voltage on D1 deflects beam approximately toward pin no. 8	
Positive voltage on D3 deflects beam approximately toward pin no. 4	
Angle between D1-D2 and D3-D4 trace	90 $^\circ$ \pm 1 $^\circ$

RATINGS (absolute maximum values)¹

Heater voltage	6.3 volts ac
Heater current at 6.3 volts	0.6 ±10% amp
Post-accelerator voltage	6000 volts dc max
Lower helix and isolation shield voltage	3000 volts dc max
D3-D4 shield voltage	3000 volts dc max
Average deflection plate voltage	3000 volts dc max
Ratio of post-accelerator voltage to average voltage of deflection plates ²	3.8 max
Astigmatism electrode voltage	3000 volts dc max
Focusing electrode voltage	800 volts dc max
Accelerator voltage	3000 volts dc max
Accelerator input	6 watts max
Grid no. 1 voltage:	
Negative-bias value	200 volts dc max
Positive-bias value	0 volts dc max
Positive-peak value	2 volts dc max
Peak heater-cathode voltage:	
Heater negative to cathode:	
During warm-up period not to exceed 15 seconds ...	180 volts dc max
After equipment warm-up period	125 volts dc max
Heater positive to cathode	125 volts dc max
Peak voltage between astigmatism and/or any deflection electrode	500 volts dc max

TYPICAL OPERATING CONDITIONS¹

Post-accelerator voltage	4000 volts dc
Lower helix and isolation shield voltage ³	900 to 1150 volts dc
D3-D4 shield voltage ³	900 to 1150 volts dc
Average deflection plate voltage	1050 volts dc
Astigmatism electrode voltage ⁴	900 to 1150 volts dc
Focusing electrode voltage ⁴	110 to 325 volts dc
Accelerator voltage	900 to 1150 volts dc
Grid no. 1 voltage ⁵	-45 to -60 volts dc
Deflection factors:	
D1 and D2 ⁶	8.4 to 10.8 volts dc/div.
D3 and D4 ⁶	8.4 to 10.8 volts dc/div.
Useful scan D1-D2 ⁷	10 div.
Useful scan D3-D4 ⁷	10 div.
Focusing electrode current for any operating condition	-10 µa to +10 µa
Spot position (undeflected) ⁸	5 mm from geometric center
Pattern distortion at 100% useful scan ⁹	1.3% max

MAXIMUM CIRCUIT VALUES

Grid no. 1 circuit resistance	1.5 MΩ max
-------------------------------------	------------

NOTES

1. All voltages taken with respect to cathode.
2. This tube is designed for optimum performance when operating at a ratio of 3.8. Operation at other ratios may result in changes in deflection uniformity, pattern distortion, and/or useful scan.
3. The isolation shield, lower end of the post-accelerator helix and the D3-D4 shields are connected internally. Pattern distortion is minimized by proper adjustment of this potential.
4. Recommended range. Adjust for best overall focus.
5. Visual extinction of undeflected spot.
6. Major graticule divisions are 8 mm.
7. The deflection plates intercept part of the electron beam near the edge of scan; therefore, a low-impedance deflection drive is desirable.
8. Connect free deflection electrodes to accelerator.
9. With a 10 x 10 div. rectangular raster centered on the face of the tube, the raster edges will not deviate from straight parallel lines by more than 1.0 mm total on the left and right edges, nor by more than 1.0 mm total at the top and bottom.

1050
300
—
750

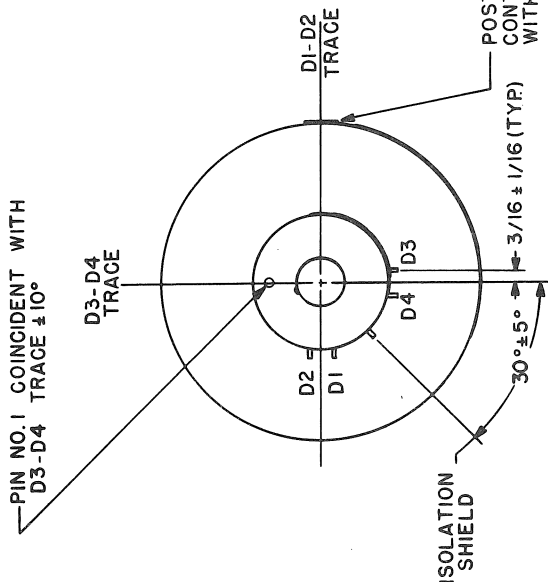
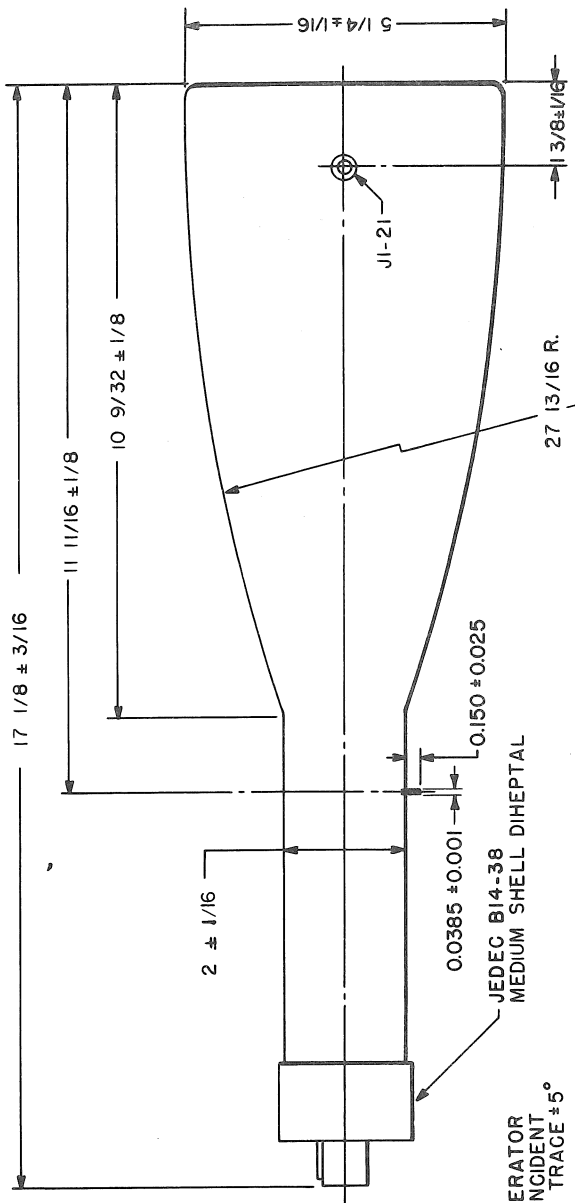

BASE CONNECTIONS

- 1, 14 HEATER
- 2 CATHODE
- 3 GRID NO. 1
- 4, 6, 7, 8, 10, N.C.
- 11, 12, 13
- 5 FOCUSING ELECTRODE
- 9 ASTIGMATISM ELECTRODE ACCELERATOR

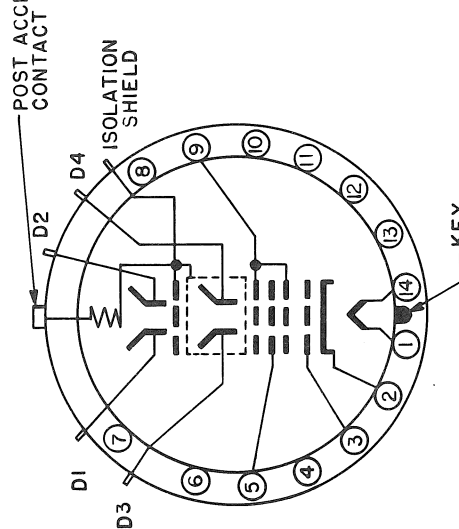

TUBE SCHEMATIC

MARK	DATE	DESCRIPTION	BY	APPR
		CATHODE-RAY TUBE DIVISION TEKTRONIX, INC. PORTLAND, OREGON, U.S.A.		
			TUBE TYPE:	T 5360