

**INSTRUCTION
MANUAL**

~~ETB~~
#19

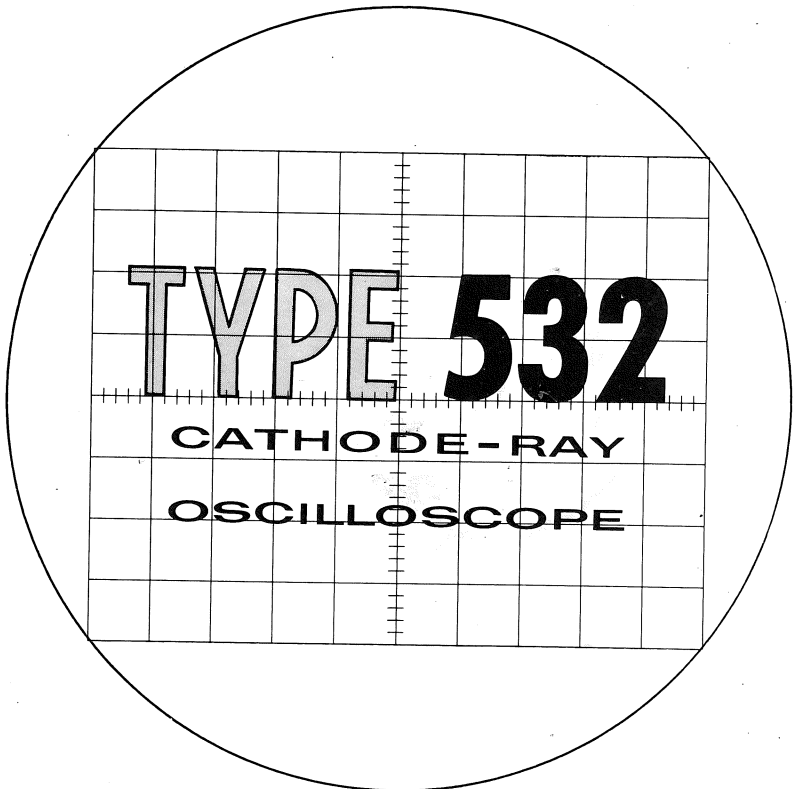

S.W. Millikan Way • P.O. Box 500 • Beaverton, Oregon • Phone MI 4-0161 • Cables: Tektronix

Sm 512

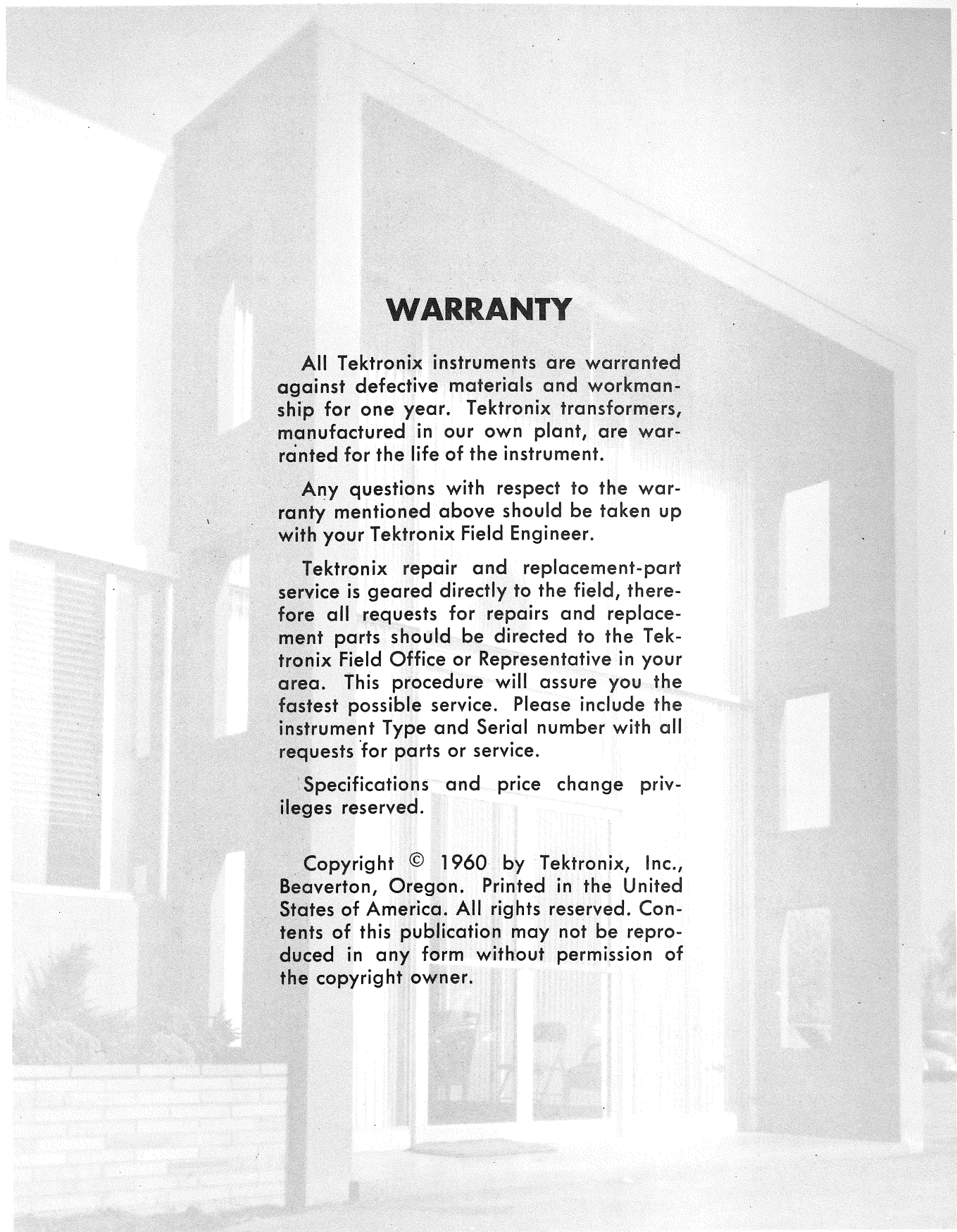

WARRANTY

All Tektronix instruments are warranted against defective materials and workmanship for one year. Tektronix transformers, manufactured in our own plant, are warranted for the life of the instrument.

Any questions with respect to the warranty mentioned above should be taken up with your Tektronix Field Engineer.

Tektronix repair and replacement-part service is geared directly to the field, therefore all requests for repairs and replacement parts should be directed to the Tektronix Field Office or Representative in your area. This procedure will assure you the fastest possible service. Please include the instrument Type and Serial number with all requests for parts or service.

Specifications and price change privileges reserved.

Copyright © 1960 by Tektronix, Inc., Beaverton, Oregon. Printed in the United States of America. All rights reserved. Contents of this publication may not be reproduced in any form without permission of the copyright owner.

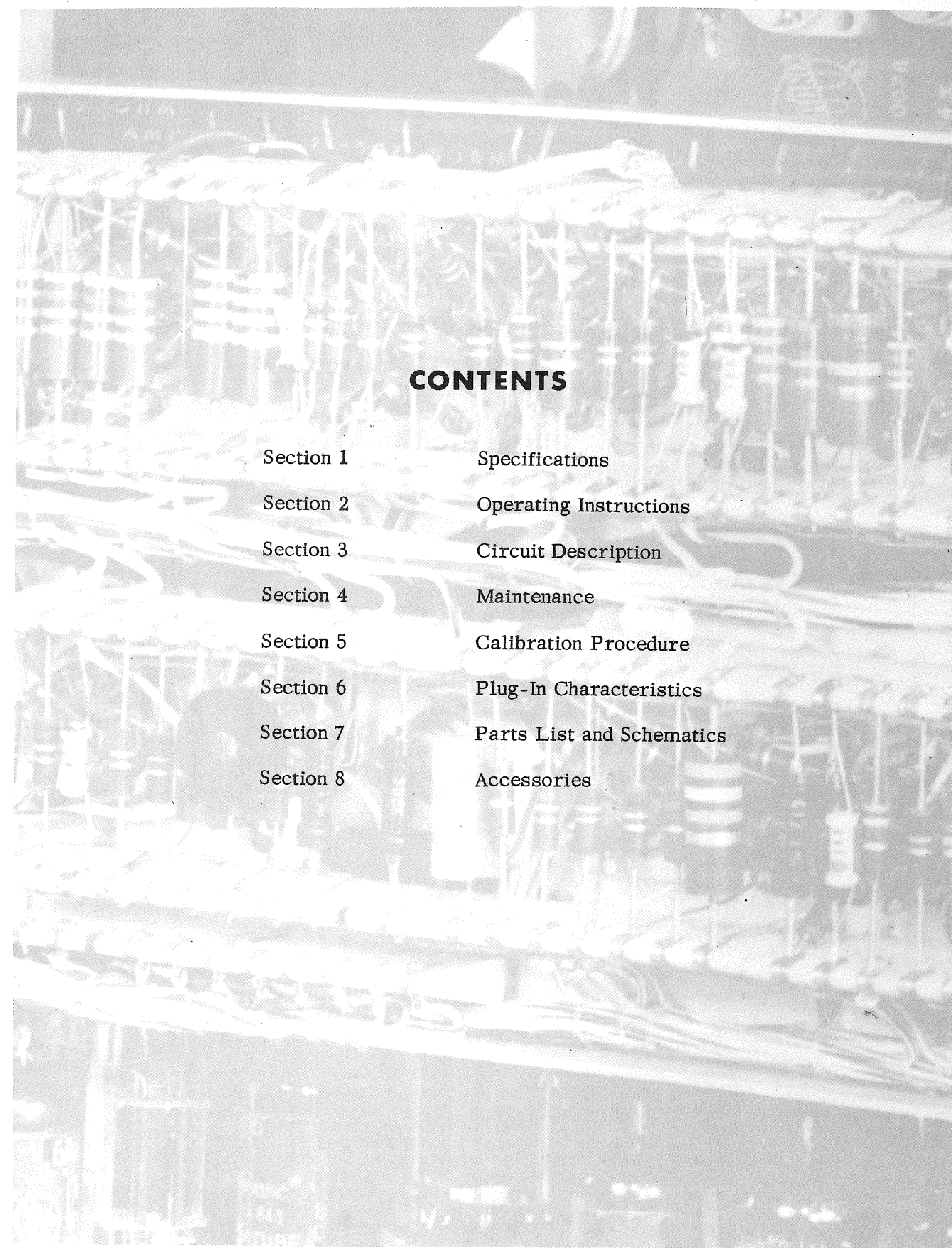

CONTENTS

Section 1	Specifications
Section 2	Operating Instructions
Section 3	Circuit Description
Section 4	Maintenance
Section 5	Calibration Procedure
Section 6	Plug-In Characteristics
Section 7	Parts List and Schematics
Section 8	Accessories

SPECIFICATIONS

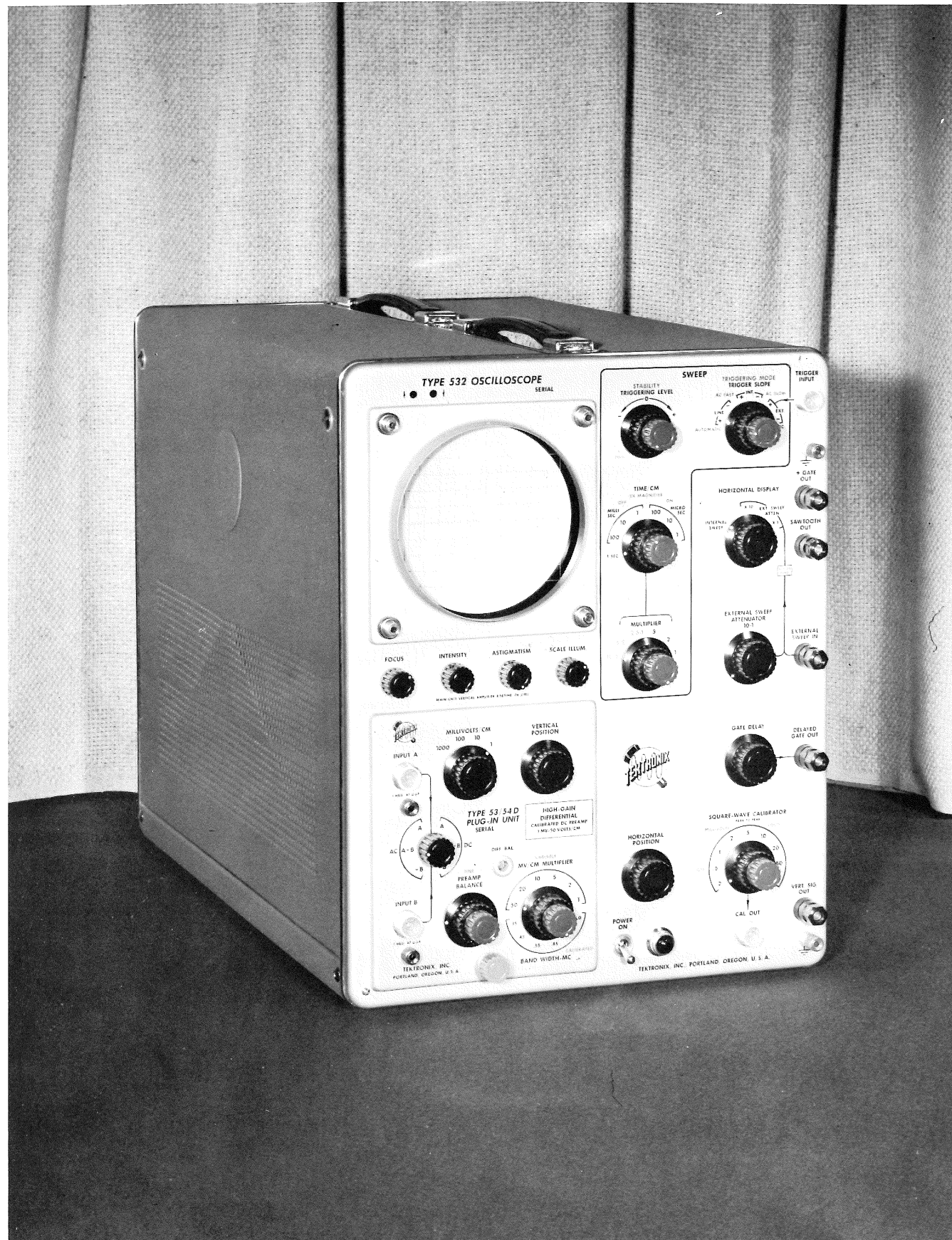
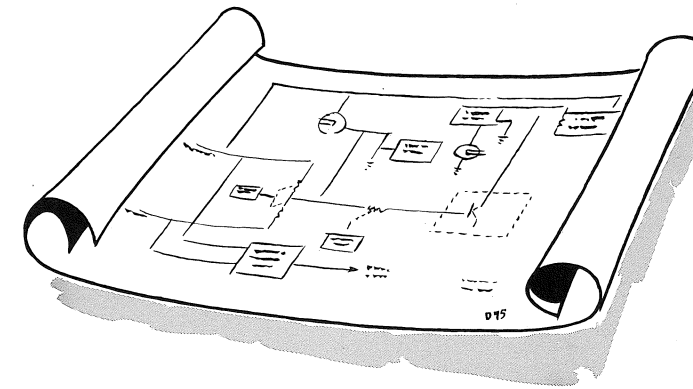

Type 532

AA

General

The Tektronix Type 532 Oscilloscope is a high-performance medium-speed, laboratory instrument with plug-in preamplifiers. It is specially engineered to get extra dependability through circuit simplicity and conservative tube loading. While achieving the extra dependability obtainable with fewer tubes more conservatively loaded, the Type 532 has retained the same precision and stability expected of Tektronix oscilloscopes, combined with performance characteristics that will take care of most of the demands of a laboratory.

Letter Series plug-in units fit the Type 532. All the versatility of these plug-in units is thus available, limited only by the 5-megacycle pass band of the Type 532.

Vertical Deflection System**Output Amplifier**

Frequency Response - dc to 5 mc.
Risetime - .06 microseconds.

Linear Deflection - 8 cm.

Horizontal Deflection System**Sweep Range**

Twenty-one calibrated speeds from 1 μ sec/cm to 5 sec/cm.

Accuracy - 3 per cent.

Continuously variable, uncalibrated, between ranges and to 12 sec/cm.

Magnifier

Expands sweep 5 times to right and left

of screen center. Extends fastest sweep speed to .2 μ sec/cm.

Accuracy - 5 per cent.

Unblanking - DC coupled.

Trigger Requirements

Internal - 2 mm of deflection.
External - .2 volts to 40 volts.
Frequency range - dc to 5 mc.

Horizontal Input**Deflection Factor**

Continuously variable, .2 v/cm to 20 v/cm.

Frequency Response - dc to 300 kc.

Other Characteristics**Cathode-Ray Tube**

Type T52P2

P1, P7 and P11 phosphors optional.

Accelerating Potential - 4,000 volts.

Deflection Factor at Plates

Vertical - 9 v/cm.
Horizontal - 22 v/cm.

Voltage Calibrator

Eighteen fixed voltages from .2 millivolts to 100 volts, peak-to-peak.

Accuracy - 3 per cent.

Waveform - square wave at about 1 kc.

AA

Specifications - Type 532

1-1

Output Waveforms Available

Positive gate of same duration as sweep, 20 volts.

Sweep Sawtooth waveform, 150 volts.

Delayed gate with delay adjustable throughout the period of the sweep and lasting for the duration of the sweep, 20 volts.

A sample of the vertical signal, pass-band dc to 2.5 mc with a 50 $\mu\mu\text{f}$ capacitive load. Output: .9 volts per cm of deflection.

Vertical Beam-Position Indicators

Indicator lights show direction of beam when it is positioned off the screen vertically.

Power Supply

Electronic Regulation

Power Requirements - 105 to 125, or 210 to 250 V, 50-60 cycles, 475 watts with the Type D Plug-In Unit.

Mechanical Specifications

Ventilation - filtered forced-air ventilation.

Finish - photo-etched, anodized panel, blue wrinkle enameled cabinet.

Dimensions - 25" long, 13" wide, 16 3/4" high.

Weight - 52 pounds.

Functions of Controls and Connectors

TRIGGERING MODE (red knob)	Four-position switch arranges trigger circuits for four kinds of triggering: AUTOMATIC, AC FAST, AC SLOW and DC.
TRIGGER SLOPE	Six-position switch selects source of trigger signal and converts to negative-going output, either negative-going or positive going input.
TRIGGER INPUT	Coaxial connector to triggering circuits through EXT. positions of TRIGGER SLOPE switch.
STABILITY	Control for adjusting the stability of the sweep circuits for a stable supply. The control has a PRESET position suitable for most triggering applications.
TIME/CM	Eight-position switch selects timing capacitors to determine sweep speeds, and determine duration of trigger-holdoff period.
MULTIPLIER	Six-position switch. Three positions place precision charging resistors in series with timing capacitors to determine sweep speeds in conjunction with selected timing capacitor. Three positions, marked in red, place adjustable charging voltages in series with timing capacitors for continuous control of sweep speeds.
5X MAGNIFIER (red knob)	Two-position switch removes or inserts attenuator in sweep amplifier to change sweep speeds by a factor of five.
HORIZONTAL DISPLAY	Three-position switch connects sweep amplifier to internal sweep generator in one position, or to front panel connector directly or through 10-1 fixed attenuator in second and third positions.

EXTERNAL SWEEP ATENUATOR, 10-1

EXTERNAL SWEEP IN

HORIZONTAL POSITION

SQUARE-WAVE CALIBRATOR (black knob)

MILLIVOLTS-VOLTS

CAL OUT

VERT SIG OUT

+GATE OUT

SAWTOOTH OUT

GATE DELAY

DELAYED GATE

POWER

FOCUS

INTENSITY

ASTIGMATISM

SCALE ILLUM

Continuously adjustable gain control on horizontal amplifier. Switched out of circuit for internal sweeps.

Front-panel connector to horizontal amplifier through HORIZONTAL DISPLAY switch. Magnifier must be switched to ON for undistorted 10-cm deflection.

Positions trace along horizontal axis.

Nine-position switch selects nine taps on precision voltage divider in calibrator circuit. Provides accurate voltages of .2, .5, 1, 2, 5, 10, 20, 50, and 100 volts in VOLTS position, or millivolts in the MILLIVOLTS position of the red concentric control knob.

1000-to-1 voltage divider to give either volts or millivolts output.

UHF coax front-panel connector from the calibrator.

Front-panel binding post supplies a sample of the vertical signal for operation of auxiliary equipment.

Front-panel binding post supplies positive 20-volt square pulse, dc coupled through cathode follower, synchronized with the internal sweep.

Front-panel binding post supplies 150-volt positive-going sawtooth dc coupled through cathode follower, synchronized with the internal sweep.

Front-panel control adjusts delay time of delayed gate. Delay is adjustable by any percentage of the sweep-sawtooth time.

Front-panel connector dc connected to cathode-follower output delivers 20-volt positive-going gate delayed according to the setting of the GATE DELAY control.

On-off switch primary of power transformer and ventilating-fan lead.

Adjustable voltage for the cathode-ray tube focusing grid.

Bias adjustment to cathode-ray tube control grid.

Adjustable voltage for the astigmatism grid of the cathode-ray tube.

Adjustable series resistor controls the voltage across the graticule lights.

Beam-position indicators, unlabeled, marked with arrows. The arrow nearest the illuminated indicator shows which way the beam is off the screen if it cannot be seen.

CRT CATHODE

Rear of Cabinet

Binding post connects to crt cathode through high-voltage capacitor. Input impedance 8k to 15k. Discharge time constant about 15 milliseconds.

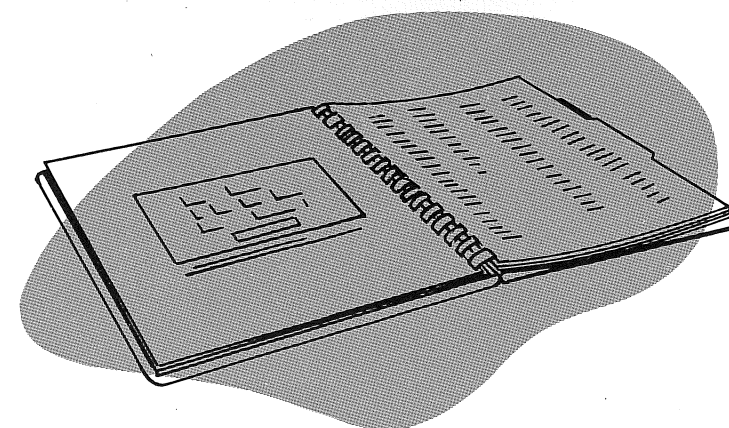

SECTION 2

OPERATING INSTRUCTIONS

Preliminary Instructions

Cooling

The Type 532 Oscilloscope is cooled by filtered, forced-air ventilation. The instrument must therefore be placed so the air intake is not blocked, and the filter must be clean enough to permit adequate air circulation. If the interior temperature does rise too high for some reason, a thermal cutout switch will disconnect the power and keep it disconnected until the temperature drops to a safe value.

Cathode-Ray Tube Controls

The Tektronix Type T52 Cathode-ray tube in this instrument has a total accelerating voltage of 4,000 volts. The spot intensity with this amount of acceleration can be bright enough to damage the screen if the spot is left in one place. Be careful not to leave a fixed bright spot on the screen. Turn the INTENSITY control counterclockwise so that the spot is dim whenever you leave the instrument unattended.

The separate FOCUS, ASTIGMATISM and INTENSITY controls are somewhat interdependent, and may require readjustment for different INTENSITY control settings.

Illuminated Graticule

The adjustable graticule-lighting control, labeled SCALE ILLUM., can be adjusted to suit the lighting conditions of the room. The colored filter supplied is colored to provide the maximum trace contrast for the P2 phosphor in the presence of room light.

The graticule is accurately scribed in centimeters and fifths of centimeters. These scale markings and the calibrated fixed vertical-deflection sensitivities and sweep times, can

be used to convert deflections in centimeters into volts and seconds. Vertical sensitivities are calibrated in volts per centimeter, and horizontal sweep-times are calibrated in seconds per centimeter which if multiplied by centimeters of deflection, give volts and seconds.

The graticule can be mounted in either of two positions rotated 180 degrees from each other. In one position, the graticule illumination is colored red, and in the other position in white. The white will reproduce well photographically.

First-Time Operation

First get a trace on the screen by the simplest method, and then proceed with the presentation you want after you get an idea of the functions of the controls. To get a trace on the screen, insert a preamplifier, for example the Type D, and proceed as follows:

Turn the POWER switch to OFF. Connect the power cord to a source of 117-volt, 60-cycle power. Then set the front-panel controls as follows:

INTENSITY	Counterclockwise (CCW)
FOCUS	center
ASTIGMATISM	center
POWER	ON
TRIGGERING LEVEL	CCW
STABILITY (red knob)	CW (S/N 101-5419) CCW (S/N 5420-5665) PRESET (S/N 5666-up)
TRIGGER SLOPE	+INT.

TRIGGERING MODE (red)	AUTOMATIC
TIME/CM	100 MICROSEC
MULTIPLIER	2
HORIZONTAL DISPLAY	INTERNAL SWEEP
HORIZONTAL POSITION	center
SQUARE-WAVE CALIBRATOR	2
VOLTS, MILLIVOLTS, OFF	VOLTS

Connect a lead from the INPUT A terminal of the Type D Preamp to the CAL. OUT terminal.

INPUT SELECTOR	INPUT A, AC
MILLIVOLTS/CM	100
VERTICAL POSITION	center
MV/CM MULTIPLIER	50
VARIABLE	Clockwise (CW)

When the POWER switch has been turned on for about one minute, turn the INTENSITY control clockwise until you can see a trace on the screen. Now back off the red STABILITY knob at the top center of the oscilloscope until the waveform is stable (S/N 101-5419). Adjust the FOCUS, INTENSITY and ASTIGMATISM controls for a sharp line. Position the trace near the screen center with the HORIZONTAL POSITION and the VERTICAL POSITION controls.

Triggering Modes

Automatic

You are now displaying the calibrator waveform, whose repetition rate is about one kilocycle, and whose amplitude is two volts, peak-to-peak, with the AUTOMATIC mode of triggering. This is the simplest mode of triggering. It is useful for general purpose viewing, and will operate satisfactorily for a wide variety

of trigger signals whose repetition rates are between sixty cycles and about two megacycles.

AC Slow

When you have a good, well focused trace of the calibrating waveform by the AUTOMATIC mode of triggering, try the other three TRIGGERING MODE switch positions. Turn the switch to the AC SLOW position. Leave the STABILITY control where you had it set for the AC AUTO triggering or advance it until the sweep starts and back it off about ten degrees (S/N 101-5665). Advance the TRIGGERING LEVEL control clockwise until you get a stable trace again. There may be a considerable range of the TRIGGERING LEVEL control over which you can get a stable trace, and the start of the trace will move up and down the edge of the square wave within this range. Notice that the trace starts on the upgoing part of the calibrator square wave.

Now turn the TRIGGER SLOPE switch to the -INT. position, and readjust the TRIGGERING LEVEL to obtain a stable trace again. Notice now that the trace starts on the down-going portion of the trace and that the position of the start can again be changed somewhat with the TRIGGERING LEVEL control.

DC Triggering

Now turn the TRIGGERING MODE switch to DC. Adjust the LEVEL control for straight triggering, and then position the trace with the VERTICAL POSITION control. You will notice that triggering occurs at a vertical level on the screen selected by the LEVEL control and that the triggering point changes relative to the waveform as the waveform is positioned vertically. This effect will be more noticeable if you look at a low-frequency sine wave.

This triggering position is most useful for low-frequency signals. It is not suitable for applications where the dc level is changing such as when the Type CA Dual-Trace Unit is being used.

AC Fast

In the AC FAST position of the TRIGGERING MODE switch, the circuit is quite similar to that in the AC SLOW position, and you

will notice no difference when displaying the calibrator waveform. The only difference is that an rc filter is inserted in the circuit, making it insensitive to low frequencies, and allowing it to recover quickly from dc level changes. This is the position to use when there is low-frequency hum present or when you are using the alternate sweep feature of the Type CA Dual-Trace unit, and you are looking at high-frequency signals.

General Triggering Instructions

The triggering system is very flexible and stable. Once you get the feel of the instrument you will find it will trigger successfully on the most difficult triggering waveforms. It will probably help if you go through the four procedures again a time or two.

If you are already familiar with the Tektronix Type 315 Oscilloscope triggering system, you will know how to operate the controls of the Type 532. If you have not had experience with this kind of triggering system, however, you will probably need some explanation, particularly if you have been using Tektronix Type 511, 512, 513 or 524 Oscilloscopes.

In the new triggering circuits, the TRIGGERING LEVEL control determines at what point on the instantaneous triggering voltage triggering will occur. This control is therefore not a sensitivity control. For small trigger signals and with ac coupling, the TRIGGERING LEVEL control will need to be set near zero. Settings below zero will cause triggering at a time when the triggering voltage is negative, with respect to its average level. Positive settings will cause triggering only at a time when the triggering voltage is positive.

The red STABILITY control knob controls the bias on the sweep multivibrator. It therefore performs about the same function as the stability controls in other Tektronix oscilloscopes. For recurrent operation, advance the control clockwise until a recurrent trace appears. For triggered operation, retard the control from this position counterclockwise ten or fifteen degrees. For most triggering signals, the PRESET position will provide a stable display without the need for adjusting the STABILITY control (S/N 5666-up).

For triggered operation, you will also need to adjust other trigger controls to select the source of trigger signals, and the level, speed, and direction of slope of the triggering waveform.

The TRIGGER SLOPE switch selects the source of trigger signals and determines whether triggering will occur on the positive-going or the negative-going portions of the triggering waveform.

Simplified Trigger Circuit Diagrams

The simplified diagrams of the triggering circuits showing the method of trigger-slope inversion and the circuit changes performed by the TRIGGERING MODE switch may help you to understand the use of the functions available in the Type 532 Oscilloscope. The following describes the circuit operations in terms of the simplified diagrams:

The trigger inverter stage is a cathode coupled amplifier. The slope polarity of the output pulse must be negative to suit the rest of the circuits that follow, so the trigger signal is connected to the amplifier so as to produce inverted output for positive signals, or in-phase output for negative signals. The TRIGGER SLOPE switch determines whether inverted or in-phase output results, by connecting either one grid or the other to the trigger source.

The trigger-shaper circuit makes a sharp pulse out of the trigger signal, and determines at what voltage level on the trigger signal the sharp trigger pulse will be generated. The trigger shaper, shown on the right, is a two-stage amplifier circuit, with two tubes coupled together through a common cathode resistor. The biases of the two tubes are set so that the input tube is conducting while the output tube is not when no triggering signal is preset. When the triggering signal pulls the input grid downward far enough it passes the level of the grid of the output section. Then the output section conducts and the input section cuts off, as the grid goes on below the cathode.

The dc level of the cathode is established by the dc input grid voltage when no triggering signal is preset. The input grid voltage is determined by the setting of the TRIGGERING LEVEL control, which sets the plate voltage

of the trigger inverting stage and thereby sets the grid voltage of the trigger shaping stage. The trigger input signal to the shaper stage thus consists of the dc level which can be adjusted, plus the amplified signal from the inverter stage. By adjusting the TRIGGERING LEVEL control, you can therefore choose what part of trigger signal will operate the shaping stage and produce a pulse at its output plate.

Additional functions of the TRIGGERING MODE switch rearrange the circuits to accommodate dc-coupled triggering, and slow or fast ac-coupled triggering.

The trigger shaper is a type of multivibrator in which regeneration causes fast transition between two stable states, regardless of how slowly the triggering signal passes the triggering level.

For dc coupling, the trigger-inverter grid is dc coupled to the input signal. For ac coupling, the trigger-inverter grid is coupled through a capacitor. For SLOW AC, the time constant of the coupling circuit is relatively long, about a millisecond. For FAST AC, the coupling time constant is much shorter, about 10 microseconds, so that the circuit will not respond to slowly changing components in the triggering waveform. For example, the AC FAST circuit will reject 60-cycle hum components, and trigger successfully on a desired higher frequency when both are present in the triggering waveform.

For the dc-triggering position, the input grid of the inverter stage assumes the actual potential of the input signal, including both the dc component and the ac component. The TRIGGERING LEVEL control will therefore need to be set to include the dc level of the trigger signal.

When the TRIGGERING MODE switch is in the AUTOMATIC position (AC AUTO position S/N 101-5419), the input grid of the inverter stage is separated from the dc level of the trigger signal, and the input grid of the trigger shaper stage is separated from the dc level of the inverter plate by capacitors. There is thus no dc coupling between the trigger input and the shaper. The trigger-shaper stage has a large (3-megohm) resistor connected between plate and grid in this switch position, so that the stage oscillates at about 50 cycles

per second, depending on the time constant of the coupling capacitor into the input grid and the 3-megohm resistor.

The input grid rises and falls about five volts in roughly a sawtooth waveform at the fifty-cycle rate. Each time the grid reverts from the negative-going direction to the positive-going direction, the output plate triggers the sweep on the scope, so that at least a zero-line trace is present whether an external source of trigger signal is present or not.

At any time during the negative-going excursion of the sawtooth, a superimposed negative trigger signal can drive the input grid of the shaper tube to cut-off and start a triggered sweep at that instant. Recurrent pulses between sixty cycles and 2 mc will synchronize the sweep in the AUTOMATIC position (AC AUTO position S/N 101-5419).

This triggering mode is useful because it will maintain a sweep, so that any signal appearing in the vertical amplifier can be displayed whether it triggers the sweep or not, and because it will provide a synchronized sweep over a wide range of trigger repetition rates with no need for readjustment of the controls.

Triggering Controls

Stability

This control sets the sweep multivibrator bias one side or the other in the region of recurrent operation. As you advance the control from the counterclockwise position, you will pass a setting at which a trace will appear in the absence of any triggering waveform. Usually you will want to trigger the sweep, and for triggered sweeps you should back the STABILITY control counterclockwise from this point five or ten degrees. Or turn the control to the PRESET position (S/N 5666-up). If you want to stop the sweep from being triggered at all, you can turn this control counterclockwise to the stop.

Triggering Level

This control selects the point on the triggering waveform at which triggering will occur. Turning the TRIGGERING LEVEL control clockwise toward the + sign causes the sweep

to be triggered during positive amplitudes of the triggering waveform. Turning the TRIGGERING LEVEL control in the - direction causes the sweep to be triggered during negative amplitudes.

Trigger Slope

This control selects the source of triggering signals, and determines whether the sweep is triggered during positive-going or negative-going portions of the triggering waveform. Used in conjunction with the TRIGGERING LEVEL control the polarity functions of this switch permit you to select any part of a triggering waveform for triggering the sweep.

How far you must turn the LEVEL control to trigger at the peak of a triggering waveform depends on the amplitude of the signal. For small signals, the LEVEL control setting will always need to be near zero, or near the dc level if there is a dc component. Increasing the amplitude of the trigger waveform while the LEVEL control remains constant will cause the triggering point to phase along the triggering waveform.

Triggering Mode

This switch arranges the circuits for single-sweep triggering on three kinds of triggering waveforms, and for recurrent sweeps which can be synchronized. The AC SLOW position is suitable for signals with a risetime of around a microsecond or slower. The DC position is the same except that it includes the dc component of the triggering waveform. The AC FAST position is suitable for risetimes faster than 10 microseconds, although there is considerable overlap between the capabilities of the circuits in the SLOW and FAST switch positions.

The AUTOMATIC position (AC AUTO position S/N 101-5419) makes a recurrent trigger signal at about a 50-cycle rate. However, it will synchronize easily with recurrent trigger signals from 60 cycles to 2 megacycles. It is a useful function for displaying signals differing widely in amplitude and triggering speed, for example, in signal-tracing techniques, and also for maintaining a base line to show that the oscilloscope is functioning when there is no signal. (In this mode, the STABILITY control is not used. Instead, an internal control

is connected into the circuit that has been preset for optimum triggering over a wide range of triggering signals. S/N 5666-up). (The STABILITY control should be set the same for this function as for other triggered operation, about five or ten degrees counterclockwise from the point where the multivibrator runs recurrently. At the fastest sweep speeds the base line will be just discernible when there is no signal because of the low duty cycle. S/N 101-5665).

Sweep Operation

Time/CM and Multiplier

The TIME/CM and MULTIPLIER controls determine the speed of the horizontal trace. The time per centimeter of horizontal deflection is equal to the product of the MULTIPLIER setting and the TIME/CM setting. Times per centimeter from 1 microsecond to 1 second in steps of 10 can be selected, with the TIME/CM switch, and accurate, fixed multipliers of 1, 2, and 5 times can be selected with the MULTIPLIER switch. The sweep times so selected can be depended on within 3 per cent of their indicated value.

Magnifier

The MAGNIFIER control inserts or removes a feedback network in the sweep amplifier that changes the gain five times. The linearity of the amplifier is somewhat better when the feedback circuit is included. The center one fifth of the trace is extended to fill the graticule when the magnifier is switched on. When the sweep magnifier is on, the fastest sweep speed is increased to .2 microseconds per centimeter. The intensity of the trace is reduced when the magnifier is on because of the reduced duty cycle.

External Sweep

In the X10 and X1 positions of the HORIZONTAL DISPLAY switch, the EXTERNAL SWEEP IN binding post is connected to the horizontal amplifier. In both of these positions the 5X MAGNIFIER must be switched to ON to keep the input amplifier within its linear range. The EXTERNAL SWEEP ATTENUATOR 10-1 can be used in conjunction with the step attenuator to give a 100-1 attenuation range.

Auxiliary Functions

Square Wave Calibrator

Accuracy of the open-circuit voltage of the calibrator is within 3 per cent of the indicated voltage. However, since the output impedance at the CAL. OUT terminal varies with the setting of the voltage-selector switch, you must be careful that the load impedance you connect it to does not change the output voltage. The output impedance reaches a maximum of about 5,000 ohms at the 50-volt tap. The frequency of the calibrator multivibrator is nominally 1,000 cycles, but may vary 30 per cent either way.

Vertical Signal Out

The signal applied to the vertical amplifier is available at the front-panel VERT. SIGN. OUT binding post. A signal which will cause one centimeter of deflection will produce a signal of about .9 volts, peak-to-peak, at the binding post. The passband is dependent on the external load. With a capacitive load of 50 μ mf, it extends from dc to 2.5 megacycles at the 3 db point.

Trace-Brightness Modulation

To couple markers or the signals into the crt cathode for brightness information, disconnect the ground strap at the rear of the instrument and connect the signal to the CRT CATHODE binding post. The input impedance is about 15,000 ohms. The circuit is ac coupled through a high-voltage capacitor with an rc time constant of about 15 milliseconds.

Direct Connection to Deflection Plates (SN 5666 up)

A plastic plate and mounting bracket is available from the factory for making direct

connections to the crt vertical-deflection plates. The mounting bracket is designed to clamp around the neck of the crt shield, adjacent to the deflection-plate connections. When mounted correctly, the plate will be accessible through the crt deflection-plate access hole in the left side-panel. The bracket and plate may be ordered with or without the necessary parts for vertical-positioning voltages. Specify part number 013-008 for the unwired unit, or part number 013-007 for the wired unit.

Holes can be drilled in the plastic plate for mounting coaxial or other connectors. The two pins on the left-hand side of the crt neck are the vertical-deflection plates.

S/N 101-5665 the plastic cover on the side of the case allows low capacitance direction connection to the deflection plates. Wire guides in the center hold the leads away from the case. The two pins on the side of the crt are the vertical deflection plates and the two on the top are the horizontal deflection plates.

To avoid distortion, the average dc potential on the vertical-deflection plates should be between 150 and 250 volts. If you use a different voltage, the distortion can be minimized by adjusting the GEOM. ADJ. control at the rear of the sweep chassis.

(Unless dc coupling is required, connect coupling capacitors in series with the leads to the deflection plates and connect one-megohm resistors from the deflection plates to the leads from the vertical amplifier. With this connection the plates are maintained at the proper operating potential, and positioning control is retained for the front-panel VERTICAL POSITION control.) S/N 5420-up.

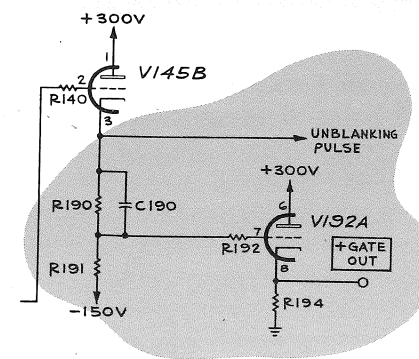

Block Diagram

The Block Diagram shows interconnections of the functional parts of the oscilloscope, except the power supplies. Functions of the switches are shown instead of their actual connections.

Vertical Amplifier

Plug-In Preamplifiers

In the upper left of the Block Diagram is shown the vertical-deflection system. The block labeled "plug-ins" represents one of the several plug-in preamplifiers available. Units are available with a wide pass band, with reduced pass band and higher sensitivity, with differential input, with channel switching for alternate trace presentation, etc. These units have calibrated gain controls and vertical position controls. Connections for power in and signal out are made through a multiple-contact mating plug and socket. Output from these units is push-pull at low impedance.

Main Unit

The main unit contains all the power supplies, the sweep system, the high-level portions of the vertical amplifier and its associated circuits, the calibrator, and the cathode-ray tube.

The driver stage feeds the vertical-deflection signal to the trigger-pickoff circuits that supply an internally derived trigger signal to trip the sweep circuits with the observed signal.

Trigger Pickoff

The pickoff circuit supplies a sample of the vertical-deflection signal to the TRIGGER SLOPE switch for triggering purposes.

SECTION 3

CIRCUIT DESCRIPTION

Vertical Output Amplifier

This amplifier raises the signal to the level needed for the vertical-deflection plates at low impedance.

Calibrator

The calibrator has no internal connection to the vertical-amplifier system. It consists of a symmetrical multivibrator with a cathode-follower output tube whose cathode resistor is a calibrated voltage divider.

Sweep

Trigger Mode and Trigger Slope Selectors

At the left of the diagram are shown the functions of the switches that select the source and slope of trigger signals and arrange the circuits to accommodate the trigger characteristics.

Trigger Phase Inverter

This stage provides either in-phase or inverted output so as to provide negative-going output for either negative-going or positive-going input trigger signals.

Trigger Shaper

The trigger-shaper amplifier makes a sharp pulse from the trigger signal at a time during the sloping part of the trigger signal determined by the setting of the triggering-level control. A sharpened negative-going pulse triggers the multivibrator.

Multivibrator

The multivibrator turns on the sweep generator and generates the crt-tube unblanking pulse when it is switched from its quiescent

state. The sharp negative-going trigger signal from the trigger-shaper circuit trips the multi-vibrator, which thereafter stays in the second state until the sweep generator reverts it to its quiescent state.

Sweep Generator

The sweep generator is a Miller integrator that produces a positive-going sawtooth about 150 volts peak-to-peak. The sweep generator turns itself off when it reaches a prescribed level determined by the sweep-length control, by transmitting a signal through the trigger-holdoff circuits to the multivibrator.

Trigger Holdoff

The trigger-holdoff circuit transmits the sweep turn-off signal to the multivibrator but briefly holds off subsequent trigger signals from starting the sweep again until all parts of the circuit have reached their quiescent states.

Sweep Amplifier

The sweep amplifier converts the sawtooth output of the sweep generator into push-pull output at low impedance at the level required to sweep the beam across the crt-tube screen. The amplifier gain can be increased by a factor of five for sweep magnification. The horizontal-positioning control operates on this stage.

Unblanking

The multivibrator generates the positive-going unblanking pulse at the same time it turns on the sweep generator. The positive pulse is transmitted by means of two cathode followers through a floating high-voltage negative supply to the control grid of the crt tube.

Delayed-Gate Circuit

The delayed-gate circuit is a bistable multivibrator which changes state when its input grid is raised above the triggering point by the sawtooth wave of the sweep generator.

An adjustable bias added to the sawtooth can move the triggering point to any position along the sawtooth. A positive pulse generated by the multivibrator is transmitted to a front-panel connector by means of a cathode-follower. The positive pulse is terminated when the sawtooth returns negative.

External-Sweep Amplifier

The external-sweep amplifier provides a means of using external sweep voltage. It includes a fixed attenuator and an adjustable attenuation control. Choice of internal or external sweep can be made by means of the HORIZONTAL DISPLAY switch. The sweep magnifier must be used with external sweeps.

Power Supply

Plate and Heater Power

The 60-cycle 117-234-volt transformer has four separate high-voltage windings. AC output from each winding is rectified by means of full-wave rectifiers. Rectified dc output is filtered with capacitors and regulated by means of series regulator tubes. Three positive voltages of 350, 225 and 100 volts are referred to -150 volts for their regulation. The negative 150-volt supply is referred to a 60-volt glow tube for its regulation.

Cathode-Ray Tube High-Voltage

A 60-kc vacuum-tube oscillator has the primary of a step-up transformer for its oscillator inductance. A sample of the rectified secondary voltage is compared to a stable dc source, and the difference is kept constant by an electronic circuit that adjusts the oscillator amplitude of oscillation in the direction to reduce any change.

Three vacuum diodes rectify stepped-up voltages at three secondary windings. Two rectifiers supply positive and negative accelerating potentials to the crt tube. The third supplies a nearly equal negative potential to the control grid of the crt tube. This supply floats on top of the unblanking pulse, which is connected in series with it to ground at its positive end.

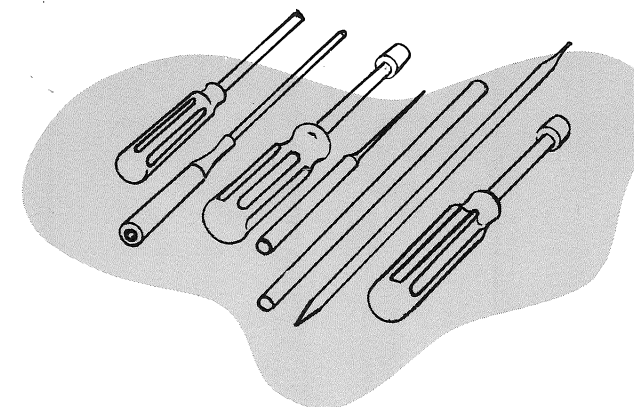

Color Coding

We use color coded wires in this instrument to help you identify the various circuits. The ac power leads are yellow and coded 1-1-0 (brown-brown-brown) following the RETMA resistor color code. The +350-volt bus is white and coded 3-5-0 (orange-green-brown beginning with the widest stripe). The -150-volt bus is black and coded 1-5-0. The heater leads are coded 6-1, 6-2, etc., not to indicate that the voltages are different but to differentiate between the leads. All signal leads have a single stripe. A few wire colors are indicated by small, lower case letters on the diagrams.

Air Filter

The Type 532 Oscilloscope is cooled by filtered forced air. If the filter gets too dirty it will restrict the flow of cooling air and may cause the instrument to overheat. The filter should be inspected every three or four months and cleaned or replaced if necessary.

Two types of air filters can be used with your Tektronix equipment. A washable air filter constructed of aluminum wool coated with an adhesive is usually supplied with your instrument. A disposable glass-wool is available through your local Tektronix field office or direct from the factory. If you are replacing an aluminum-type filter with the disposable glass-wool type, it is best to order No. 378-009, which includes two back-up screens that help to prevent damage to the filter. For future replacements of the glass-wool filter only, order No. 378-012.

To clean the aluminum filter, run hot water through it from the side that was inside. Or slosh it around in hot soapy water and rinse it in clean water. Then dry it thoroughly and coat it with "Filter Coat", a product of the Research Products Corporation. Pint

SECTION 4

MAINTENANCE

cans are available under the name "Handi-Koter" from some air-conditioner suppliers. Other adhesive materials are no doubt satisfactory.

Fan Motor

The fan motor bearings will require oiling every few months or every thousand hours of operation. Use a good grade of light machine oil, and apply only a drop or two.

Soldering and Ceramic Strips

Many of the components in your Tektronix instrument are mounted on ceramic terminal strips. The notches in these strips are lined with a silver alloy. Repeated use of excessive heat, or use of ordinary tin-lead solder will break down the silver-to-ceramic bond. Occasional use of tin-lead solder will not break the bond if excessive heat is not applied.

If you are responsible for the maintenance of a large number of Tektronix instruments, or if you contemplate frequent parts changes, we recommend that you keep on hand a stock of solder containing about 3% silver. This type of solder is used frequently in printed circuitry and should be readily available from radio-supply houses. If you prefer, you can order the solder directly from Tektronix in one-pound rolls. Order by Tektronix part number 251-514.

Because of the shape of the terminals on the ceramic strips it is advisable to use a wedge-shaped tip on your soldering iron when you are installing or removing parts from the strips. Fig. 4-1 will show you the correct shape for the tip of the soldering iron. Be sure and file smooth all surfaces of the iron which will be tinned. This prevents solder from building up on rough spots where it will quickly oxidize.

When removing or replacing components mounted on the ceramic strips you will find that satisfactory results are obtained if you proceed in the manner outlined below.

1. Use a soldering iron of about 75-watt rating.

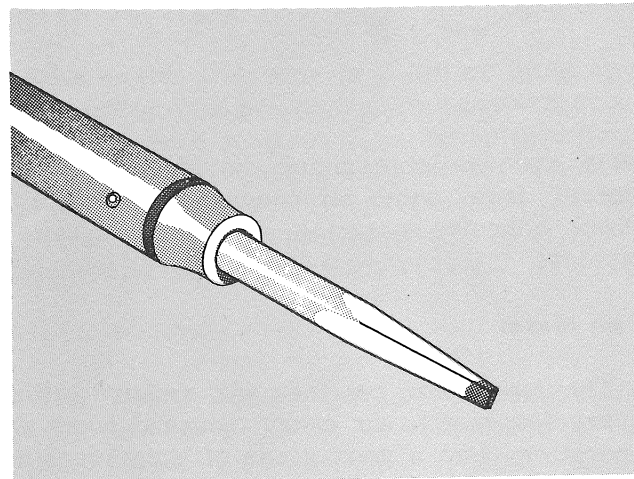

Fig. 4-1. Soldering iron tip correctly shaped and tinned

2. Prepare the tip of the iron as shown in Fig. 4-1.

3. Tin only the first 1/16 to 1/8 inch of the tip. For soldering to ceramic terminal strips tin the iron with solder containing about 3% silver.

4. Apply one corner of the tip to the notch where you wish to solder (see Fig. 4-2).

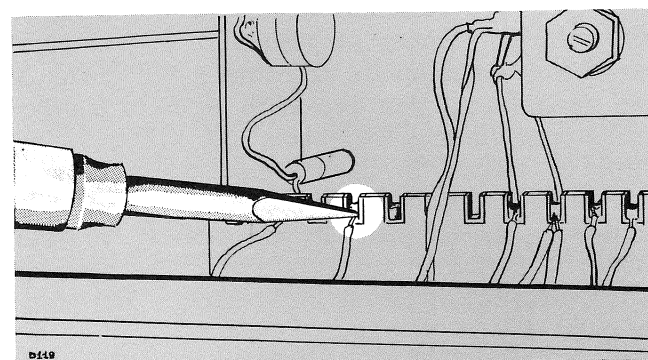

Fig. 4-2. Method of applying heat to ceramic strip.

5. Apply only enough heat to make the solder flow freely.

6. Do not attempt to fill the notch on the strip with solder; instead, apply only enough solder to cover the wires adequately, and to form a slight fillet on the wire as shown in Fig. 4-3.

In soldering to metal terminals (for example, pins on a tube socket) a slightly different technique should be employed. Prepare the iron as outlined above, but tin with ordinary tin-lead solder. Apply the iron to the part to be soldered as shown in Fig. 4-4. Use only enough heat to allow the solder to flow freely along the wire so that a slight fillet will be formed as shown in Fig. 4-3.

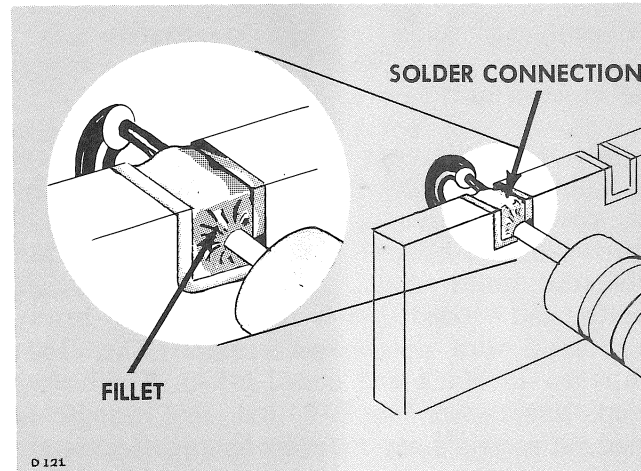

Fig. 4-3. Note the slight fillet formed on a correctly soldered joint.

General Soldering Considerations

When replacing wires in terminal slots clip the ends neatly as close to the solder joint as possible. In clipping the ends of wires take care the end removed does not fly across the room as it is clipped.

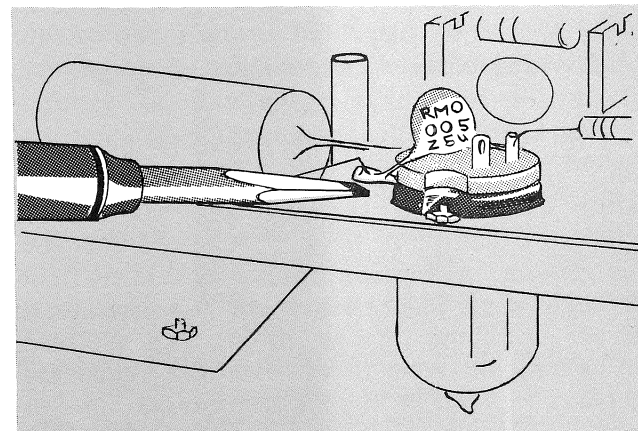

Fig. 4-4. Soldering to a metal pin.

Occasionally you will wish to hold a bare wire in place as it is being soldered. A handy device for this purpose is a short length of wooden dowel, with one end shaped as shown in Fig. 4-5. In soldering to terminals pins mounted in plastic rods it is necessary to use some form of "heat sink" to avoid melting the plastic. A pair of long-nosed pliers (see

Fig. 4-6) makes a convenient tool for this purpose.

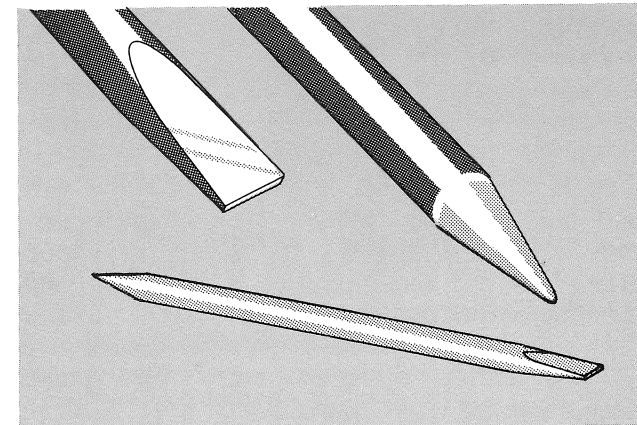

Fig. 4-5. A wooden dowel shaped for use as a soldering aid.

Ceramic Strips

Two distinct types of ceramic strips have been used in Tektronix instruments. The earlier type mounted on the chassis by means of #4-40 bolts and nuts. The later is mounted with snap-in, plastic fittings. Both styles are shown in Fig. 4-7.

To replace ceramic strips which bolt to the chassis, screw a #4-40 nut onto each mounting bolt, positioning the bolt so that the distance between the bottom of the bolt and the bottom of the ceramic strip equals the height at which you wish to mount the strip above the chassis. Secure the nuts to the bolts with a drop of red glyptal. Insert the bolts through the holes in the chassis where the original strip was mounted, placing a #4-40 lockwasher between each nut and the chassis. Place a second set of #4-40 lockwashers on the protruding ends of the bolts,

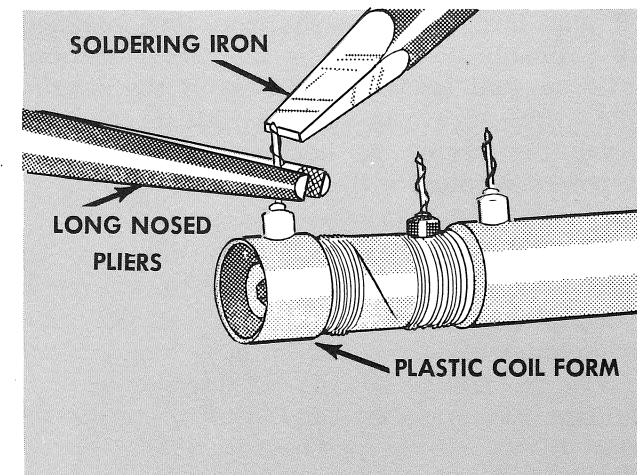

Fig. 4-6. Long-nosed pliers used as a heat sink.

and fasten them firmly with another set of #4-40 nuts. Place a drop of red glyptal over each of the second set of nuts after fastening.

Mounting Later Ceramic Strips

To replace strips which mount with snap-in plastic fittings, first remove the original fittings from the chassis. Assemble the mounting post on the ceramic strip. Insert the nylon collar into the mounting holes in the chassis. Carefully force the mounting post into the nylon collars. Snip off the portion of the mounting post which protrudes below the nylon collar on the reverse side of the chassis.

NOTE

Considerable force may be necessary to push the mounting rods into the nylon collars. Be sure that you apply this force to the upper ends of the mounting rods rather than to the ceramic strip.

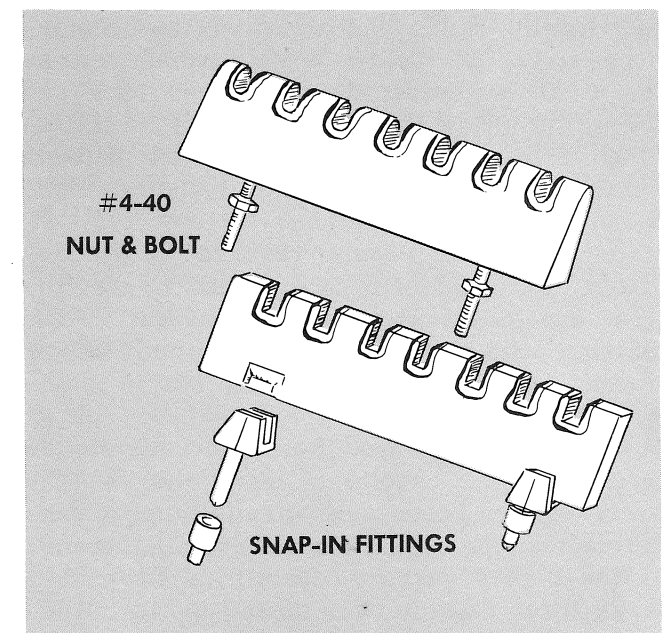

Fig. 4-7. Old and new styles of ceramic strips. The newer ceramic strips mount in nylon collars.

Trouble Shooting

If the instrument fails to operate at all, including the fan and the pilot light, check the source of power and determine that the power cord plug is firmly in place. Then check the 5-amp fuse at the back of the instrument near the power receptacle.

If the fan and pilot light operate but there is no spot visible, there is a possibility that

CALIBRATION
PROCEDURE

the spot is positioned off the screen for some reason. Check whether the beam-position-indicator lights are operating and if the positioning controls produce any effect. Advance the INTENSITY control and see if there is some unfocused glow on the screen to indicate the presence of beam current. If there is an indication that there is a beam positioned off the screen, look for a dc component in one of the input signals.

This is a complex electronic instrument. There is no simple way of locating troubles. An understanding of the functions of the circuit is the best help. With an understanding of the circuits, you will be able to make a good guess at the general source of troubles from their symptoms. Be doubly sure that the difficulty you are having is not caused by some misadjustment on the front-panel controls. If not, you will need to take the case off for further checks.

Each side panel and the bottom panel are individually removable when service becomes necessary. To remove a side panel, release the fasteners near the front and back and swing the top of the panel out until the bottom hinge releases. To remove the bottom panel release the four fasteners and lift the panel off.

To replace the panels, reverse the process above. Each fastener is designed so that the first one-quarter turn engages an ear on the fastener with the oscilloscope frame. Further turning of the screw locks the ear in place.

Warning: When you have the case off the instrument, be careful of high voltages. The lower-voltage buses are potentially more dangerous than the crt accelerating voltage because of the higher current capabilities and rather large filter capacitors in these supplies. When you reach into the instrument while it is turned on, do not hold the metal frame with the other hand. If possible, stand on an insulated floor and use insulated tools.

Troubles are usually caused by tube failure, and you can frequently correct them by finding the bad tube and replacing it with a good one. However, sometimes a tube burns up resistors or overstresses capacitors when it fails, and in these cases you will also have to find the bad components. Sometimes you can find them by visual inspection. One way to find bad tubes is to try replacing suspected tubes with good ones. If possible, replace all suspected tubes at one time, and if the trouble is helped, return the old ones one at a time until the offending one is discovered.

Tube failure will often show up in the voltage readings of the power supply. So another early step to take when you look for troubles is to check voltages and currents from the regulated power supplies. The voltages can be measured at the ceramic strip mounted on the right side of the center bulkhead. The -150-volt terminal should read within two per cent of 150 volts. The remainder of the voltages should be within three to five per cent of their indicated voltages. Keep in mind that these are quite close tolerances, especially the 150-volt tolerance. Very few portable voltmeters have comparable accuracy, so be sure that any small discrepancy you may find is not due to voltmeter error.

All of the positive voltage supplies refer to -150 volts for their control. If this voltage is off, all other voltages will also be off. The -150-volt supply can be adjusted by means of a screwdriver control marked -150 ADJ. on the power supply chassis near the rear. The remaining supplies cannot be adjusted, and any large discrepancy you find in them will probably be caused by tube deterioration, or by unusual loads in the rest of the instrument. Be sure the plug-in unit is plugged in and the series dc heaters are lighted or the power supplies will not regulate.

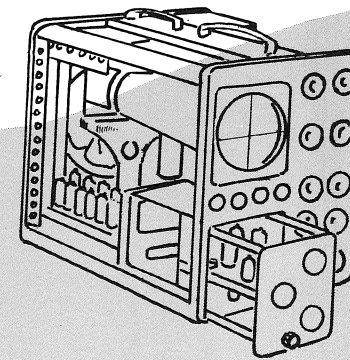

The Type 532 is a stable instrument and should not require frequent calibration. However, it will be necessary to calibrate certain parts of the instrument when tubes or components are changed, and periodic calibration is desirable from the standpoint of preventive maintenance.

In the instructions that follow, the steps are arranged in the proper sequence for full calibration. Each numbered step contains the information necessary to make one adjustment. If a complete calibration is not necessary, you may perform individual steps, PROVIDING that the steps performed do not affect other adjustments. It is most important that you are fully aware of the interaction of adjustments. Generally speaking, the interaction of controls will be apparent in the schematic diagram. If you are in doubt, check the calibration of the entire section on which you are working.

If you make any adjustments on the power supplies, you will have to check the calibration of the entire instrument. In particular the sweep rates and vertical deflection factors must be checked.

Equipment Required

The following equipment is necessary for the complete calibration of the Type 532 Oscilloscope:

(1). A DC voltmeter having a sensitivity of at least 5000 Ω/v and calibrated for an accuracy of at least 1% at 100, 150, 225 and 350 volts, and for an accuracy of at least 3 per cent at 1650 volts. Portable multi-meters should be regularly checked against an accurate standard and corrected readings noted, where necessary, at the above listed voltages. BE SURE YOUR METER IS ACCURATE.

(2). An accurate rms-reading ac voltmeter, having a range of 0-150 volts. (0-250 or 0-300 for 234 v operation.)

(3). Variable auto-transformer (e.g. Powerstat or Variac) having a rating of at least 6.25 amperes.

(4). Time-mark Generator, Tektronix Type 180, 180A or equivalent, having markers at 1 μsec , 10 μsec , 50 μsec , 100 μsec , 1 msec, 5 msec, 10 msec, 100 msec, 1 sec and 5 sec. and sine-wave outputs of 50 kc and 5 mc, all having an accuracy of at least 1%.

(5). Square-Wave Generator, Tektronix Type 105 or equivalent, having a risetime of no more than .02 microseconds and a frequency of approximately 100 kc. The top of the square wave must be free of overshoot and wrinkles. A type P93 Coaxial Cable and a Type B93-R Terminating Resistor is required with the Type 105.

(6). Constant-amplitude Signal Generator with frequencies to 50 kc and 5 mc., accurate within at least 2%.

(7). Tektronix Type K or other appropriate Plug-In Unit.

(8). Low-Capacitance Recalibration Tools: Tektronix part numbers 003-000, 003-007, and 003-301.

(9). Test Oscilloscope, Tektronix Type 316 or equivalent, providing triggered sweeps and a bandpass of at least dc to 10 mc.

Preliminary

Remove the side covers and bottom plate from the instrument to be calibrated and install the Plug-In Unit.

Set the front-panel controls as follows:

INTENSITY	full left
HORIZONTAL DISPLAY	Internal Sweep
TRIGGERING MODE	AC Slow
TRIGGER SLOPE	+ INT
STABILITY	full left, but not PRESET
TIME/CM	1 MILLISEC
MULTIPLIER	CALIBRATED (full right)
CALIBRATOR	OFF
PLUG-IN UNIT	
AC/DC	DC
VOLTS/CM	.05
VARIABLE	CALIBRATED (full right)

NOTE

Settings for all controls not listed above are not pertinent to this part of the procedure and the controls may be left in any position.

Check the rear panel of the instrument to be sure the metal strap between CRT CATHODE and GND binding posts is in place. Connect the instrument and the ac meter to the autotransformer output and turn on all equipment. Adjust the autotransformer to the design-center voltage for which your instrument is wired (117 or 234 v.) and allow at least 5 minutes warmup before making any adjustments.

Procedure

1. Low-Voltage Power Supplies

Measure the output voltage of the -150v, 100v, +225v and +350v supplies at the points indicated on the bottom view, Fig. 5-1. Be sure your meter is accurate. The output voltage of the -150v supply must be between -147v and -153v, and the other regulated supplies

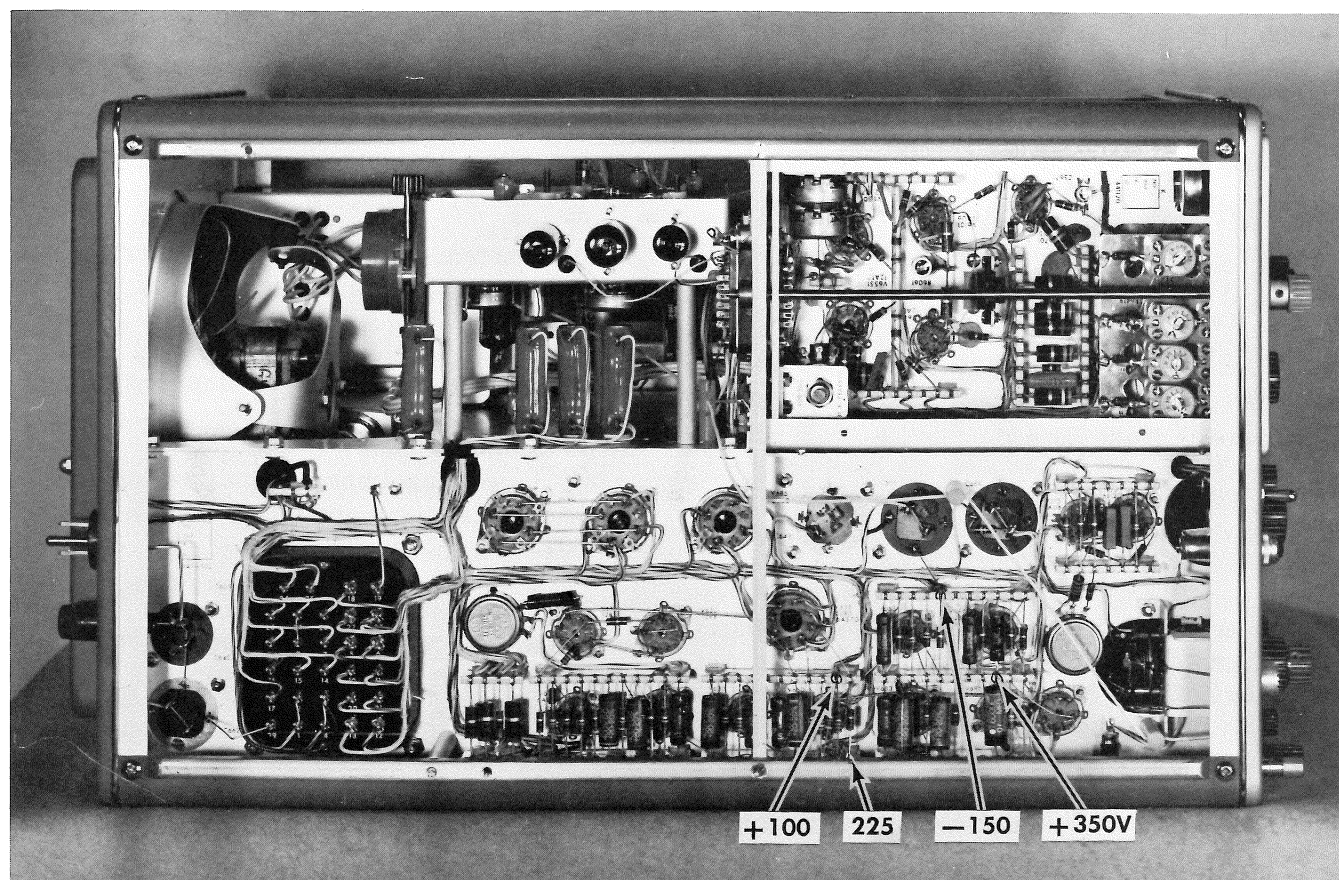

Fig. 5-1. Type 532, bottom view showing voltage check points.

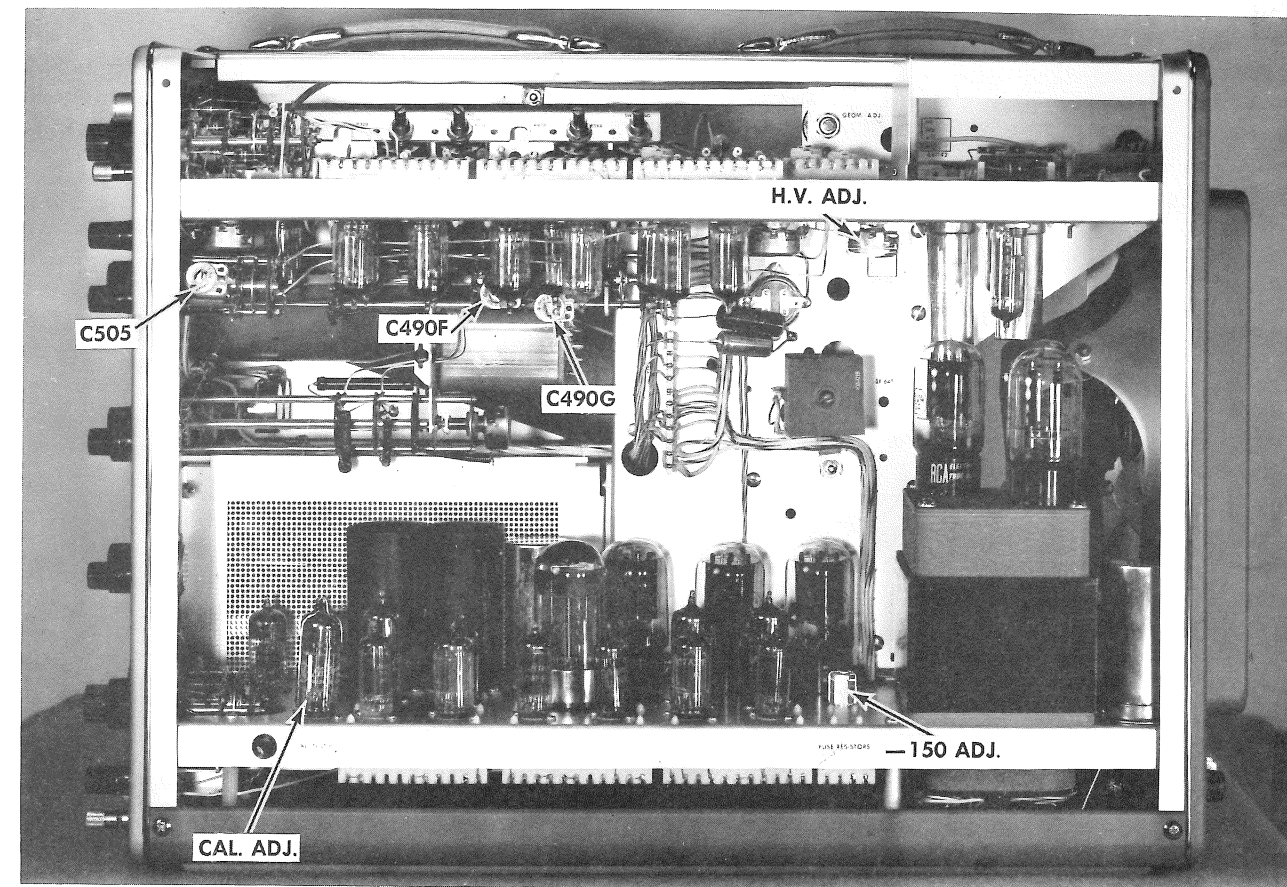

Fig. 5-2. Type 532, Right side view.

must be within 2% of their rated values. You should be able to set the -150 ADJ. control (see Right Side View, Fig. 5-2) so that all of these voltages are within the specified tolerance. Bear in mind that the calibration of the entire instrument is affected by changes in the power supply voltages. Don't adjust the -150v unless one or more of the supplies is actually out of tolerance.

To check the above supplies for proper regulation, vary the autotransformer voltage between 105v and 125v (or from 210v to 250v if the power transformer is connected for 234v operation). All of the regulated voltages should remain essentially constant.

The ripple present on any of the regulated supplies, as measured with a test scope at the voltage check points, will be well under 10 mv., with CALIBRATOR OFF, and the Type 532 sweep not operating.

2. SQUARE-WAVE CALIBRATOR Adjustment

The Cal. Adj. control should be set to provide a dc output of 100 volts when the VOLTS-

MILLIVOLTS-OFF switch is in the OFF position. Under these conditions, the calibrator output will be within 3% of the front-panel readings.

To make this adjustment connect the voltmeter between the Cal. Test Point jack and ground (see Right Side View, Fig. 5-2), turn the VOLTS-MILLIVOLTS-OFF switch to the OFF position, and adjust the Cal. Adj. control for a reading of exactly 100 volts. To assure suitable symmetry of the calibrator waveform, the reading at this point should not be less than 45v or more than 55v when the calibrator is turned on to any of the output voltage settings. Readings outside this range are generally caused by unbalanced multivibrator tubes (V205 or V215).

3. High-Voltage Power Supply Adjustment

This adjustment determines the total accelerating potential on the crt, and thus affects the deflection sensitivity.

Connect the voltmeter between ground and the high-voltage check point (see Top View, Fig. 5-3), and set the H.V. Adj. (see Right

Side View, Fig. 5-2) for a meter reading of exactly -1650 volts

4. CRT Alignment

If the crt has been replaced, or if, due to considerable handling, the trace does not align with the graticule, you should make this adjustment before proceeding with the calibration.

Push the crt forward until it rests snugly against the graticule, and tighten the crt base clamp. Turn the STABILITY control full right to free-run the sweep. Position the trace directly behind the center graticule line. By turning the crt rotating knob (see Left Side View, Fig. 5-4), align the trace with the graticule line.

5. CRT Geometry

Geometry of the crt display is adjusted by means of the GEOMETRY control. To achieve optimum linearity, vertical lines are displayed on the crt and the GEOMETRY control is adjusted for minimum curvature of the lines. Nonlinearity is most noticeable at the edges of the graticule.

Set the front panel controls as follows:

HORIZONTAL DISPLAY	INTERNAL SWEEP
TRIGGERING MODE	AC
TRIGGER SLOPE	+ INT
TIME/CM	100 MICROSEC

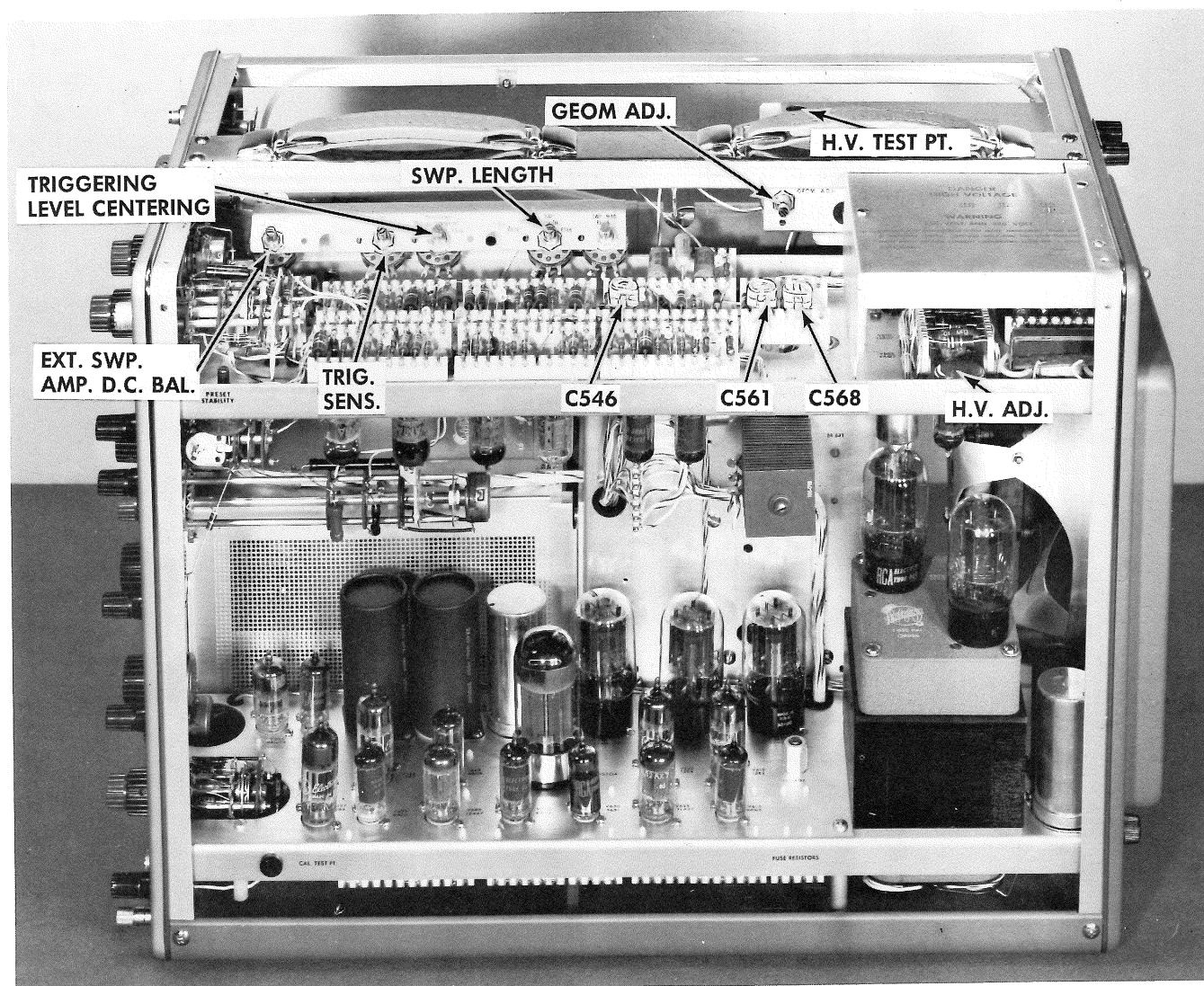

Fig. 5-3. Type 532, Top view.

MULTIPLIER 5
VOLTS/CM (Plug-In) .2

Connect 500 μ sec from the Type 180 markers to the INPUT connector and position the baseline of the timing comb below the bottom of the crt face so it is not visible. Adjust the GEOMETRY control (see Top View, Fig. 5-3) for straight vertical lines running parallel to the left and right edges of the graticule. See Fig. 5-6.

NOTE

The square-wave calibrator may be used for this step, but due to the low intensity of the vertical lines, the adjustment is somewhat more difficult.

6. Vertical Amplifier Balance

To balance the output stage of the Vertical Amplifier, place a screwdriver across the crt leads labeled "Blue (Upper)" and "Brown (Lower)" and observing the vertical position of the display.

CAUTION

In shorting the crt vertical deflection plate leads by this means, be extremely careful that your screwdriver or other shorting device does NOT touch the crt shield.

After noting the position of the trace with vertical deflection plates shorted, place a short

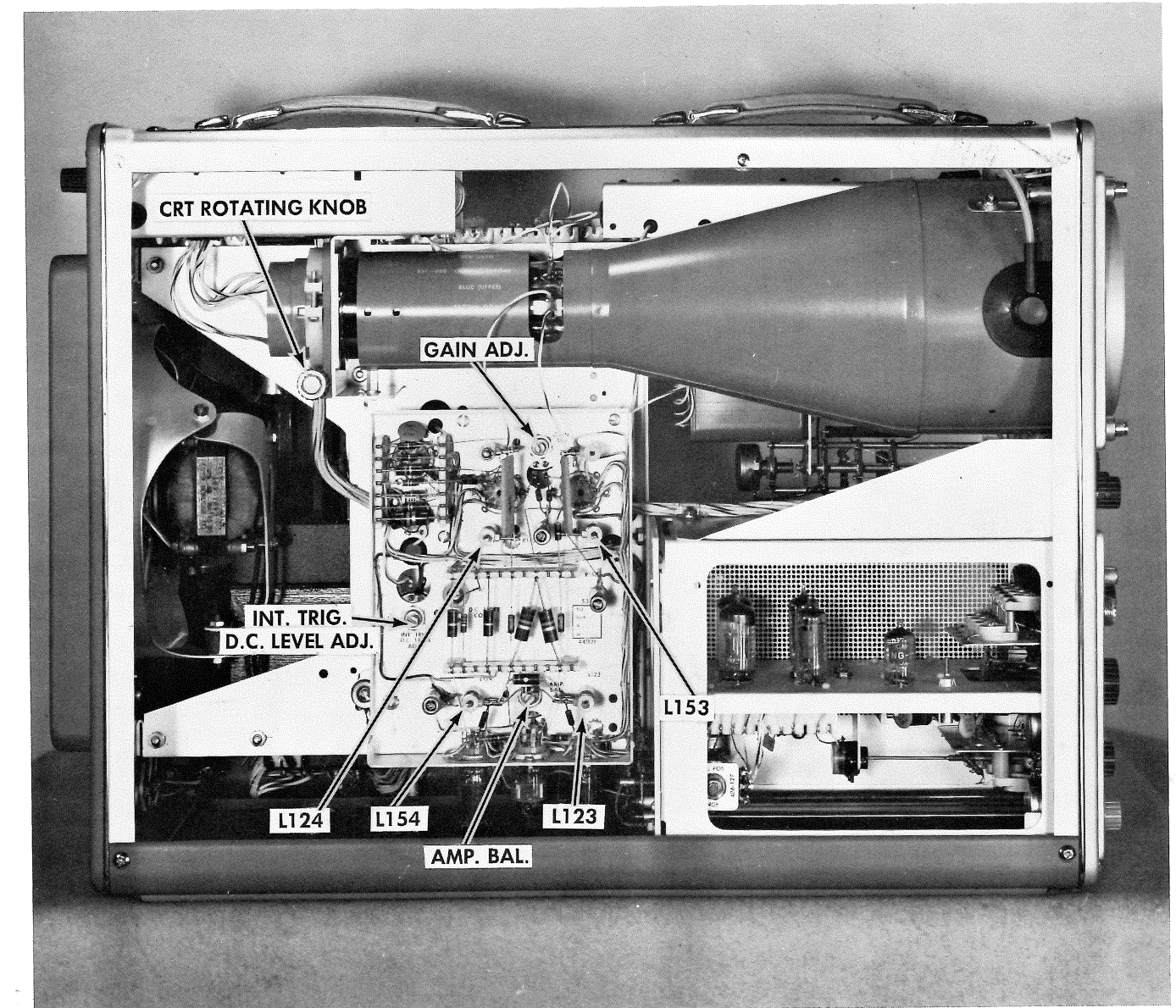

Fig. 5-4. Type 532, Left side view.

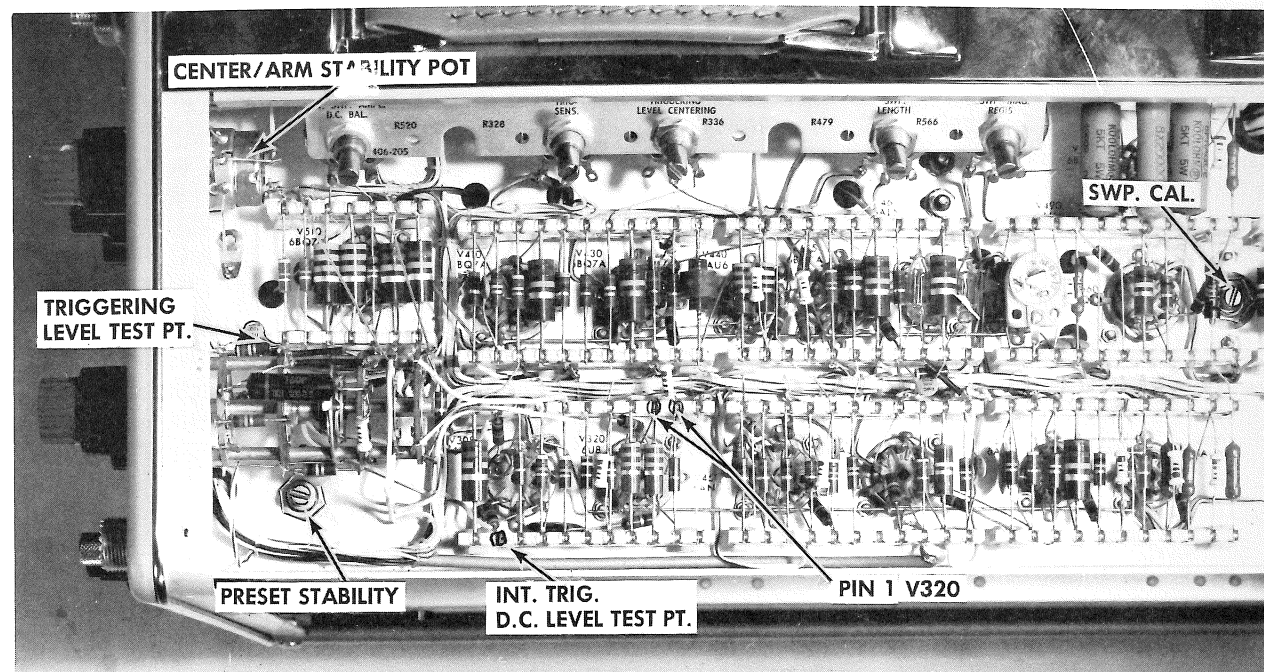

Fig. 5-5. Type 532, Top left. Triggering control adjustment points.

clip lead between the grids, pins 9, of V151 and V152, and again observe the vertical position of the trace. If it has moved more than 1 cm, it will be necessary to select better balanced 6CL6 tubes for V151 and V152.

Next, remove the clip lead and set the VERTICAL POSITION control on the Plug-In unit to top center. Adjust AMP. BAL. control (see Left Side View) to center the trace vertically.

7. Vertical GAIN ADJ.

Set Plug-In VOLTS/CM control to .1 and from the SQUARE-WAVE CALIBRATOR, apply .2 volts of signal to the INPUT. Set GAIN ADJ. (see Left Side View) for 2 cm of vertical deflection.

8. Triggering Level

Set the TRIGGERING MODE control to DC, TRIGGER SLOPE to +INT. Connect the dc voltmeter from the junction of R316 and R317 (470K resistors on the TRIGGER MODE switch (see Fig. 5-5) to ground. Set the voltmeter on its lowest range, and adjust TRIGGERING LEVEL so that the meter reads exactly zero volts. Note the position of the TRIGGERING LEVEL control. If it is at any position other

than zero, loosen and set screw and re-position the knob so that the TRIGGERING LEVEL knob is at zero when the dc voltmeter reads zero. After setting it, leave the TRIGGERING LEVEL control at zero volts during the trigger circuit adjustments as follow.

9. Internal Trigger DC Level

Leaving the scope controls as before, shift the dc voltmeter probe to R308, 100Ω resistor to pin 9 of V308. (See Fig. 5-5). Switch the TRIGGER SLOPE from +INT. to -INT. and set INT. TRIG. DC LEVEL ADJ. (See Left Side View) so that the meter again reads zero volts.

10. Trigger Level Centering and Trigger Sensitivity

Set the TRIGGERING MODE switch to AC SLOW and the TRIGGER SLOPE to +LINE. Set the Test Scope VOLTS/CM switch to .2, AC. Connect the test scope probe to pin 1, V320 (see Fig. 5-5) on the scope being calibrated, and adjust TRIGGERING LEVEL CENTERING (see Top View) so that the waveform on the test scope is symmetrical. For fine adjustment, switch the Test Scope MAGNIFIER to ON, and horizontally center the switching portion of the waveform. Switch the TRIGGER

SLOPE switch of the scope under calibration back and forth from +LINE to -LINE, and at the same time re-adjust the TRIGGERING LEVEL CENTERING control until there is no horizontal shifting of the switching portion of the waveform displayed on the Test Scope.

With all controls left unchanged, advance the TRIG. SENS. control (see Top View) until oscillation occurs at the leading and trailing edges of the Test Scope waveform. This is evidenced by spikes forming at the leading and trailing edges, and lengthening as the TRIG. SENS. control is turned further clockwise, finally breaking into oscillation. Note the amplitude of the spikes at the point of oscillation, and back off the TRIG. SENS. control until the spikes are at slightly less than half of the amplitude they show at the oscillating point.

11. Adjust Preset Stability

Turn the triggering controls to AUTOMATIC, +LINE. Turn the PRESET STABILITY control

(see Fig. 5-6) until the sweep just triggers. When this occurs, a trace first appears on the crt. Continue to advance the PRESET STABILITY clockwise until the trace suddenly brightens, indicating free-running of the sweep. With the dc voltmeter connected from the center arm of the STABILITY pot (see Fig. 5-5) to ground, the triggering point should read about -80 volts on the meter, the free-run point from 15 to 25 volts higher. After determining the voltages of the two points, turn the PRESET STABILITY control to obtain a meter reading halfway between them.

12. Adjust External Sweep Amplifier DC Balance

Connect the SAWTOOTH OUT to the Plug-In Vertical INPUT. Switch the HORIZONTAL DISPLAY to EXT. SWEEP X1, 5X MAGNIFIER to ON. Turn the EXTERNAL SWEEP ATTENUATOR 10-1 back and forth, and adjust EXT. SWP. AMPL. D.C. BAL. so that there is no horizontal shift of the vertical trace displayed when the EXTERNAL SWEEP ATTENUATOR 10-1 is rotated.

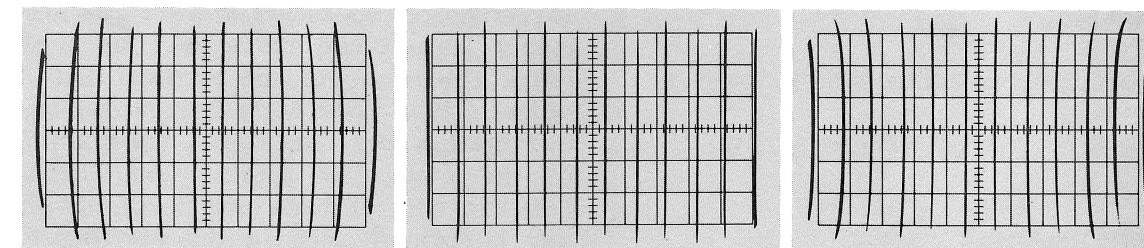

Fig. 5-6 Adjusting CRT Geometry. Compensate to obtain the display in the center illustration.

13. Compensate External Sweep and Check External Sweep Attenuation

Set the SQUARE-WAVE CALIBRATOR for .5 volts of signal and connect CAL OUT. to EXTERNAL SWEEP IN. With SAWTOOTH OUT connected to vertical INPUT, set trigger controls for EXTERNAL triggering and connect a jumper from either CAL. OUT or SAWTOOTH OUT to TRIGGER INPUT. Adjust triggering controls for a triggered display. Set VOLTS/CM to 10, and adjust C546 (see Top View) for a flat top square-wave display. Increase the Calibrator square-wave signal to 5 volts and set EXT. SWEEP ATTEN. to X10. Stabilize the display again and note the 10 times attenuation of display. Adjust C505 (see Right Side View) for a flat top display. Rotate EXTERNAL SWEEP ATTENUATOR 10-1 and check for at least 10 times attenuation.

14. Adjust Sweep Calibration

Set HORIZONTAL DISPLAY to INTERNAL SWEEP, TIME/CM to 1 MILLISEC, and MAGNIFIER to OFF. From the Type 180A, apply 1 millisecond Markers to vertical INPUT. Adjust SWP. CAL. (see Top View) for 1 marker per cm of display. Whenever timing adjustments are made during calibration procedure, make them between the 1 cm and 9 cm lines on the graticule.

15. Set Sweep Length

Adjust HORIZONTAL POSITION control so that the sweep starts at the left edge of the graticule. Set SWP. LENGTH control (see Top View) so that the sweep runs for approximately 10.5 cm.

16. Adjust Magnifier Calibration

Set TIME/CM to 1 MILLISEC. Apply 1 millisecond and 100 μ second time markers from the Type 180A to the vertical INPUT. Turn the MAGNIFIER to ON and adjust MAG. CAL. (see Top View) so that 1 large mark is displayed every 5 cm, and 2 small markers every cm. Check to see that the display is linear over its entire length.

17. Adjust Sweep Magnifier Register

Leaving all controls as in the preceding step, position the trace so that the first time marker falls on the center line of the graticule. Turn the MAGNIFIER to OFF and adjust the SWP./MAG. REGIS. (see Top View) so that the first mark again falls on the center line of the graticule. Check to see that the MAGNIFIER ON and MAGNIFIER OFF positions register properly at the middle and the end of the sweep.

18. Check Sweep Rates, 5 seconds/CM to 100 μ seconds/CM

Adjust oscilloscope controls as follows:

HORIZONTAL DISPLAY	INTERNAL SWEEP
TRIGGERING MODE	AC
TRIGGER SLOPE	+INT
MAGNIFIER	OFF
VOLTS/CM (Plug-In)	2

Check Sweep Rates in accordance with the table below:

TIME/CM	TIME-MARK GENERATOR	MARKERS
1 MILLISEC	1 MILLISEC	1 per cm
2 MILLISEC	1 MILLISEC	2 per cm
5 MILLISEC	5 MILLISEC	1 per cm
10 MILLISEC	10 MILLISEC	1 per cm
100 MILLISEC	10 MILLISEC	1 per cm

1 SEC	1 SEC	1 per cm
2 SEC	1 SEC	2 per cm
5 SEC	5 SEC	1 per cm
100 μ SEC	100 μ SEC	1 per cm

19. Check Sweep Rate Variable Multiplier Control

With TIME/CM set to 1 MILLISEC and 1 millisecond markers inserted from the Type 180A, set the MULTIPLIER to 2.5-1 and rotate the red MULTIPLIER knob counterclockwise. By observing the compression of the time markers as the MULTIPLIER control is rotated, check for a MULTIPLIER range of at least 2.5-1. Repeat the procedure on the 5-2 and 12-5 settings of the MULTIPLIER control.

20. Adjust Sweep Rates, 10 μ sec to .2 μ sec/cm

Set TIME/CM to 10 μ SEC. Adjust the sweep for triggered operation on +INT and AC SLOW. Apply 10 μ second markers from the Time-Mark Generator to the vertical INPUT, and adjust C490F (see Right Side View) to display one marker per cm. Check the starting point of the sweep by rotating the TRIGGERING LEVEL control back and forth. If there is any horizontal shift in the starting point of the sweep, re-adjust C546 (see Top View) to eliminate any shift in sweep start.

Next, switch TIME/CM to 1 μ SEC and apply 1 μ second markers to the vertical INPUT. Adjust C490G (see Right Side View) to display 1 marker per cm, and C561 (see Top View) for linearity at the start of the sweep. These adjustments will interact, and some shifting back and forth between them may be necessary to obtain optimum results.

Switch the MAGNIFIER to ON, and re-set triggering controls to +INT and AC FAST. From the Time-Mark Generator, insert a 5 mc sine-wave signal to the vertical INPUT. Set controls for triggered operation and horizontally position the display so that either the tops or the bottoms of the sine waves fall behind vertical graticule markers. Then adjust C568 (see Top View) so that 1 cycle/cm is displayed. The first two cycles of the display can be disregarded in making this adjustment.

21. Check EXTERNAL SWEEP IN Horizontal Deflection Factor

Switch the HORIZONTAL DISPLAY to EXT. SWEEP ATEN. X1 and turn the MAGNIFIER to ON. Apply .2 volts of calibrator Square wave to EXTERNAL SWEEP IN. Check for between 1.25 and 1.6 cm of horizontal deflection.

22. Adjust Vertical Amplifier High Frequency Compensations

From the Type 105 Square-Wave Generator, apply a 100 kc signal to the vertical INPUT and adjust amplitude settings to obtain 3 cm of vertical deflection. Adjust L123, L124, L153 and L154 so that the displayed square wave has an optimum square front corner. Switch the Type 105 and 1 kc and connect the 10X

probe from the test scope to the VERT. SIG. OUT connector on the scope under test. Adjust C175 (see Left Side View) to produce approximately a 3% spike on the leading edge of the vertical signal out waveform displayed on the test scope. Switch the Type 105 back to 100 kc and recheck the high frequency compensations previously made.

23. Check Vertical Frequency Response

From a Type 190A Constant Amplitude Sine-Wave Generator, apply a 50 kc signal to the vertical INPUT. Adjust amplitude for 4 cm of deflection. Without adjusting other controls, switch the Type 190A to a 5 mc output. Check for at least 2.8 cm of vertical deflection still remaining.

Type 532 Plug-in Preamplicifier Characteristics

Type N

The Type N Sampling Unit is designed for use with Tektronix plug-in type Oscilloscopes. The sampling system thus formed permits the display of repetitive signals with fractional nanosecond (10 second or nsec) risetime. By taking successive samples at a slightly later time at each resurgence of the pulse under observation, the Type N reconstructs the pulse on a relatively long time-base. Specifications of the Type N include a risetime of 0.6 nsec, corresponding to a maximum band-pass of approximately 600 mc; a sensitivity of 10 mv/cm with 2 mv or less noise; and a dynamic range of +or- 120 mv minimum linear range before overloading results.

Accidental overload of +or- 4 volts dc is permissible.

Type P

The Type P Plug-In Unit generates a fast rise step-function test signal of known waveform, simulating the output of an ideally compensated Type K Unit driven with a Tektronix Type 107 Square-Wave Generator. The Type P permits the standardization of the main-unit vertical amplifier transient response of a Tektronix convertible oscilloscope. Pulse repetition rate is 240 step-functions per second, with either positive or negative polarity. Step function amplitude is continuously adjustable between 0 and 3 major graticule divisions.

Type Q

The Type Q Plug-In Unit permits any Tektronix convertible oscilloscope such as the Type 532 to be operated with strain gages and other transducers. Excitation voltages for the strain gages and transducers are provided by the plug-in unit. The unit provides high gain, low noise, and extremely low drift. Frequency response of the Type Q Plug-In Unit is DC to 6 kc; risetime is approximately 60 microseconds.

Strain sensitivity is calibrated in 10 steps from 10 microstrain per major graticule division to 10,000 microstrain per division, and is continuously variable between steps.

Type R

The Type R Plug-In Unit is a combined power supply and pulse generator which is used to measure the high-frequency characteristics of junction transistors by the pulse-response method. When the Type R is used in an oscilloscope having a delay line; delay time, risetime, storage time, and falltime may be displayed simultaneously. A pushbutton switch connects a front-panel terminal directly to the input of the oscilloscope for observing externally derived waveforms.

Pulse risetime of the Type R Unit is less than 5 nanoseconds, so measurements depend on the risetime of the oscilloscope used. Pulse amplitudes are in 8 fixed, calibrated steps from .05 to 10 volts, adjustable between steps. Pulse recurrence frequency is 120 pulses per second.

Type S

The Type S Plug-In Unit is designed for use with Tektronix Wide-Band convertible oscilloscopes. Using the Type S, voltage across a test diode is displayed as a function of time.

Certain diode parameters, such as junction resistance, junction capacitance, and the stored charge at the junction, can be measured readily and reliably from the display. Performance of a diode in a particular circuit can be predicted by analyzing the recovery and the "turn-on" characteristics. Since it is essentially a means for plotting voltage across an element while passing constant current through it, the unit can be used for other applications as well. For example: observing the junction characteristics of transistors, or measuring the resistance, capacitance, or inductance of circuit components.

The Type S offers calibrated forward currents in five fixed steps from 1 to 20 milliamps, and reverse currents calibrated in six steps from 0 to 2 milliamps. Diode shunt capacitance is 9 picofarads, and deflection factors are 0.05 v/cm and 0.5 v/cm, calibrated.

PLUG-IN PREAMPLIFIER CHARACTERISTICS WITH TYPE 532 OSCILLOSCOPE

PLUG-IN TYPE	CALIBRATOR DEFLECTION FACTOR	PASSBAND	RISETIME	INPUT CAPACITANCE
TYPE A Wide-Band DC Coupled	0.05 v/cm to 20 v/cm	dc to 5 mc	70 nsec	47 pf
TYPE B Wide-Band High-Gain	5 mv/cm to 0.05 v/cm 0.05 v/cm to 20 v/cm	2 c to 5 mc dc to 5 mc	70 nsec	47 pf
TYPE CA Dual-Trace DC Coupled	0.05 v/cm to 20 v/cm	dc to 5 mc	70 nsec	20 pf
TYPE D High-Gain DC Coupled Differential	1 mv/cm to 50 v/cm	dc to 2 mc	0.18 μ sec	47 pf
TYPE E Low-Level AC Coupled Differential	50 μ v/cm to 10 mv/cm	0.06 cycles to 60 kc	6 μ sec	50 pf
TYPE G Wide-Band DC Coupled Differential	0.05 v/cm to 20 v/cm	dc to 5 mc	70 nsec	47 pf
TYPE H DC Coupled High-Gain Wide-Band	0.005 v/cm to 20 v/cm	dc to 5 mc	70 nsec	47 pf
TYPE K Fast-Rise DC Coupled	0.05 v/cm to 20 v/cm	dc to 5 mc	70 nsec	20 pf
TYPE L Fast-Rise High-Gain	5 mv/cm to 2 v/cm 0.05 v/cm to 20 v/cm	3 c to 5 mc dc to 5 mc	70 nsec	20 pf
TYPE N* Pulse Sampling	10 mv/cm	600 mc	0.6 nsec	Input Impedance 50 ohms
TYPE P* is a fast-rise step-function test signal unit.				
TYPE Q* Strain Gage	10 μ strain/div to 10,000 μ strain/div	dc to 6 kc	60 μ sec	Adjustable
TYPE R* Transistor Risetime	0.5 ma/cm to 100 ma/cm		70 nsec	
TYPE S* Semiconductor Diode Recovery	0.05 v/cm and 0.5 v/cm			
TYPE T*	Time-Base Generator			
TYPE Z* Differential Comparator	0.05 v/cm to 25 v/cm	dc to 5 mc	70 nsec	27 pf

*More data available on the special purpose plug-in units in the accompanying paragraphs.

Type T

The Type T Time-Base Generator provides sawtooth sweep voltages from 0.2 $\mu\text{sec}/\text{div}$ to 2 sec/div . The trigger source may be line frequency, external, ac or dc coupled, automatic of high-frequency sync. The triggering point can be on either rising or falling slope of the waveform, and triggering level is adjustable. A signal of 0.2 volts to 50 volts is required for triggering.

Type Z

The Type Z Plug-In Unit extends the accuracy of oscilloscope voltage measurements. It can be used in three modes of operation: (1) as a conventional preamplifier, (2) as a differential input preamplifier, or (3) as a calibrated differential comparator. With sensitivity of 50 mv/cm and insertion voltage range of

+or- 100 volts, the effective scale range is +or- 2000 cm . Maximum resolution of the Type Z Unit is .005%.

As a conventional preamplifier, the Type Z Unit offers a passband of dc to 5 mc with the Type 532 for signals that do not overscan the screen. The deflection factors are 0.05 volts/cm to 25 v/cm in 9 fixed, calibrated steps.

As a differential input preamplifier, the Type Z accepts a common-mode signal level +or- 100 volts with input attenuation X1, and offers a common-mode rejection ratio of 40,000 to 1. Maximum input signal is + 1 volt/7 nsec , or - 1 volt/5 nsec .

As a calibrated differential comparator, the Type Z makes available three comparison voltage ranges; from zero to +or- 1 volt, zero to +or- 10 volts, and zero to +or- 100 volts.

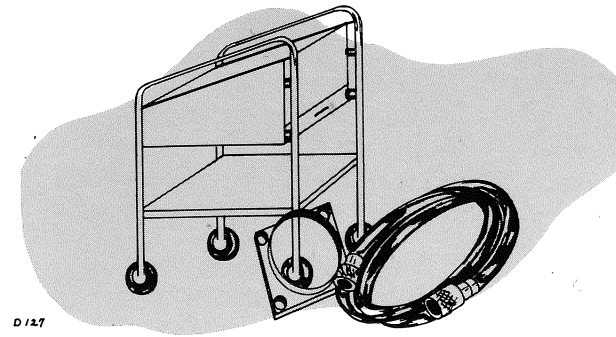

D 127

General Information

Your Tektronix instrument has been designed and built to give you maximum performance and versatility. However, for some special applications, there are special accessories available which will increase the versatility of your instru-

SECTION 8

ACCESSORIES

ment even more. The accessories which are particularly suited to this instrument are listed in this section.

Accessories should be ordered from your Tektronix Field Engineer or through your nearest Tektronix Field Office by Tektronix part number. Complete, up-to-date price information is also available through your Tektronix Field Engineer or Field Office.

PROBES

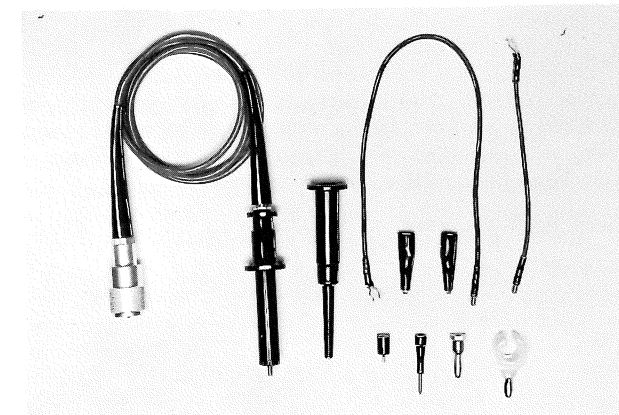

P6000 Low-Capacitance High-Performance Probe—The P6000 to P6005 probes preserve the transient response of Tektronix fast-rise, wide-bandpass instruments. These probes are free of overshoot and ringing and have uniform frequency response. They are easy to handle, of rugged construction, and weigh about one ounce. Compensation is accomplished by the rotation of a tubular capacitor; no tools are necessary.

Physical dimensions of the probe body are 7/16 inch in diameter and 3 $\frac{5}{8}$ inches in length without the tip. The standard cable length is 42 inches.

Five interchangeable tips—two straight, one hooked, one pincher, and one banana tip are included with the probe. A 5-inch and a 12-inch ground lead are also included.

PROBE SPECIFICATIONS

Probe & Connector	Cable Length	Atten. Ratio	Input Impedance		Voltage Rating (Max.)	
			Resist. Meg Ω	Capacitance—pf		
				Min. *		Max. **
P6000-UHF P6003-BNC	42 inch	10X	10	11.5	14.5	600
	6 foot			12.5	15.5	
	9 foot			15.0	18.0	
	12 foot			17.5	20.0	
P6001-UHF P6004-BNC	42 inch	1X	1	68	95	600
	6 foot			94	121	
	9 foot			120	147	
	12 foot			146	173	
P6002-UHF P6005-BNC	42 inch	100X	9.1	2.5	2.8	2000
	6 foot			2.8	3.25	
	9 foot			3.5	4.0	
	12 foot			3.8	4.0	

* When connected to instruments with 20 pf input capacitance.

** When connected to instruments with input capacitance up to 50 pf.

(A)

TEKTRONIX PART NUMBERS

	P6000	P6001	P6002	P6003	P6004	P6005
42 inch	010-020	010-023	010-024	010-027	010-028	010-029
6 foot	010-030	010-032	010-034	010-031	010-047	010-050
9 foot	010-035	010-033	010-043	010-045	010-048	010-051
12 foot	010-041	010-042	010-044	010-046	010-049	010-052

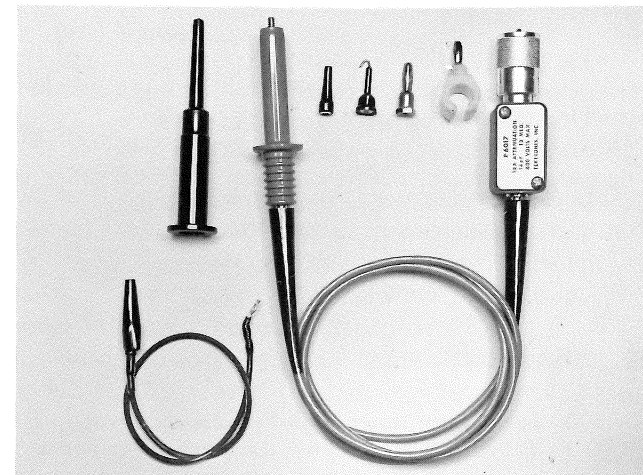

P6017 Attenuator Probe—Provides an attenuation of ten times when used with Tektronix oscilloscopes and amplifiers. The P6017 is small and streamlined, and presents an input impedance of 10 megohms paralleled by 14 pf. Probe has a 42" cable with coaxial connector, and is rated at 600 v maximum.

PROBE SPECIFICATIONS

Probe & Connector	Cable Length	Atten. Ratio	Input Impedance		Voltage Rating (Max.)	
			Resist. Meg Ω	Capacitance—pf Min. * Max. **		
P6017-UHF P6022-BNC	42 inch	10X	10	14	14	600
	6 foot			17	17	
	9 foot			20	20	
	12 foot			23	23	
P6027-UHF P6028-BNC	42 inch	1X	1	67	94	600
	6 foot			93	120	
	9 foot			120	147	
	12 foot			146	173	

* When connected to instruments with 20 pf input capacitance.
** When connected to instruments with input capacitance up to 50 pf.

TEKTRONIX PART NUMBERS

	P6017	P6022	P6027	P6028
42 inch	010-038	010-064	010-070	010-074
6 foot	010-056	010-066	010-071	010-075
9 foot	010-057	010-067	010-072	010-076
12 foot	010-058	010-068	010-073	010-077

P6016 AC Current Probe Systems—The P6016 AC Current Probe and Type 131 Amplifier constitute a current detecting system for use with any wide-band oscilloscope. This system provides accurate displays for observation and measurement of a-c current waveforms. Current range extends from less than one milliampere to 15 amperes. Use of the current probe and amplifier combination will cause risetime and bandpass figures to deteriorate somewhat from those advertised in the manual for the oscilloscope with which the current probe system is being used.

A second system comprises the P6016 AC current probe with a Passive Termination. Although less versatile than the Type 131 amplifier system, the passive termination arrangement does provide slightly better bandpass.

Long narrow shape and convenient thumb control make the P6016 easy to use. Just place probe slot over conductor and close slide with thumb—no direct electrical connection is required. Wiping action keeps core surfaces clean. Loading introduced is so light that it can almost always be disregarded. For increased sensitivity, loop the conductor around the probe slot two or three times.

ORDER PART NUMBER 010-037

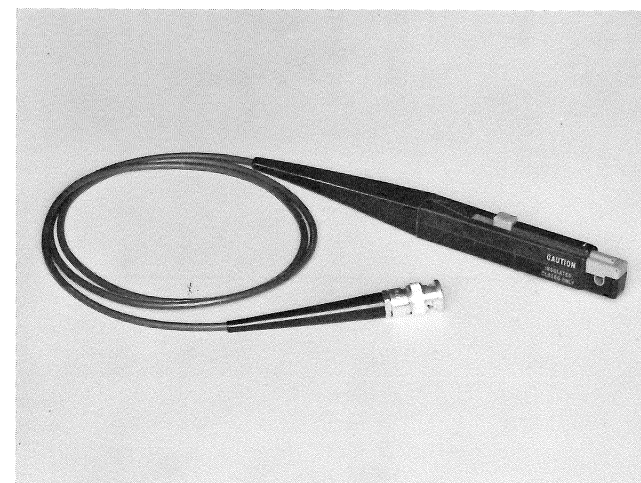

The Type P6014 High-Voltage Probe—This new probe provides a means of observing, on an oscilloscope, waveforms of high amplitudes and relatively short duty cycle. DC amplitudes up to 12 kv or short pulses with peak amplitudes up to 25 kv can be measured without damage to the probe.

- Attenuation Ratio—1000 to 1.
- Frequency Response—dc to over 30 mc.
- Input Impedance—10 megohms and 3 pf.
- Pulse Rating—10% or less duty cycle with maximum pulse duration of 0.1 sec.

A compensating box on the oscilloscope end enables the P6014 probe to be properly compensated to any oscilloscope having an input capacitance of 20 to 47 pf. The probe introduces no ringing or overshoot.

Probe body length is 12 inches, coaxial cable length is 10 feet.

The probe includes 2 banana-plug tips, an alligator-clip assembly, and an attached 7 1/2 inch ground lead.

ORDER PART NUMBER 010-025

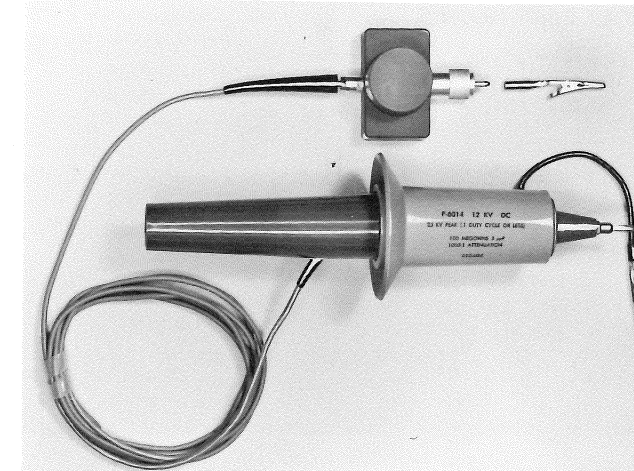

P170CF Cathode-Follower Probe. The cathode-follower tube is a 5718 triode whose cathode load is the 170-ohm termination of the preamplifier grid line in the Type 517. Plate and heater voltages for this tube are provided at a four-terminal socket on the panel of the oscilloscope. The signal is attenuated by 2 times when using the P170CF. The input impedance of the probe will depend on the attenuator head being used, also since transit time in the cathode-follower tube is involved, it will decrease appreciably at the higher frequencies. When the probe is used without an attenuator head, the input looks like 12 megohms shunted by 5 pf. The probe cable is 42" long. Probe complete with 3 attenuator heads

ORDER PART NUMBER 010-101

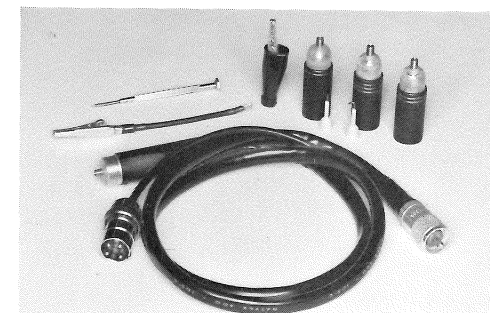

Replacement Attenuator Heads

PAX-I Attenuator Head for P170CF, attenuation can be varied between 4 times and 40 times.

ORDER PART NUMBER 010-301

PAX-II Attenuator Head for P170CF, attenuation can be varied between 20 times and 200 times.

ORDER PART NUMBER 010-302

PAX-III Attenuator Head for P170CF, attenuation can be varied between 200 times and 2000 times.

ORDER PART NUMBER 010-303

P500CF Cathode-Follower Probe—Presents low capacitance with minimum attenuation. Input impedance is 40 megohms paralleled by 4 pf, gain 0.8 to 0.85. Input to probe is ac-coupled, limiting its low-frequency response to

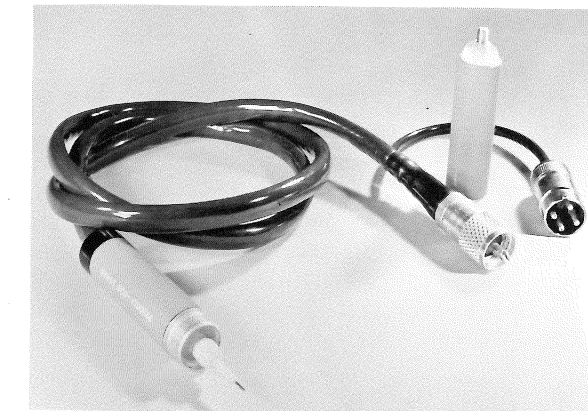

5 cycles. Amplitude distortion is less than 3% on unidirectional signals up to 5 volts. 10x attenuator head is included with probe, and should be used on signals exceeding a few volts to minimize amplitude distortion. With the attenuator head attached, the probe input impedance is approximately 10 megohms paralleled by 2 pf. Probe output level is 11 v positive, making it necessary to use the ac-coupled position of the oscilloscope AC-DC switch. Probe cable is 42" long.

ORDER PART NUMBER 010-105

TYPE 128 PROBE POWER SUPPLY

Type 128 Probe Power Supply—For P500CF and P170CF cathode-follower probes. The Type 128 supplies the neces-



sary plate and filament voltages for one or two probes, making it possible to use the cathode-follower probes with oscilloscopes not equipped with a probe-power outlet.

- DC Output Voltages:
- +120 v regulated, at 25 ma
- Two +6.3 v unregulated, at 150 ma

The two cathode-follower probe connections have separate +6.3 v dc voltage supplies.

When a P170CF probe is to be used with an instrument other than the Tektronix Type 517, a 170-ohm terminating resistor is required. The Tektronix 011-016, 170 ohms, 0.5 w Terminating Resistor is recommended for this purpose.

Ripple on the 120 v supply is not more than 5 mv peak-to-peak, and not more than 75 mv peak-to-peak on the 6.3 v supplies.

Power Requirements—105 to 125 v or 210 to 250 v, 50 to 60 cycles, 25 watts using two P500CF probes.

CALIBRATION ACCESSORIES

The Type TU-2 Test-Load Plug-In Unit is a convenient special-purpose test tool for the maintenance of Tektronix Type 530, 530A, 540, 540A-Series Oscilloscopes. The unit is used to check power-supply regulation under high load and low load demands of all A to Z plug-in units. It can also

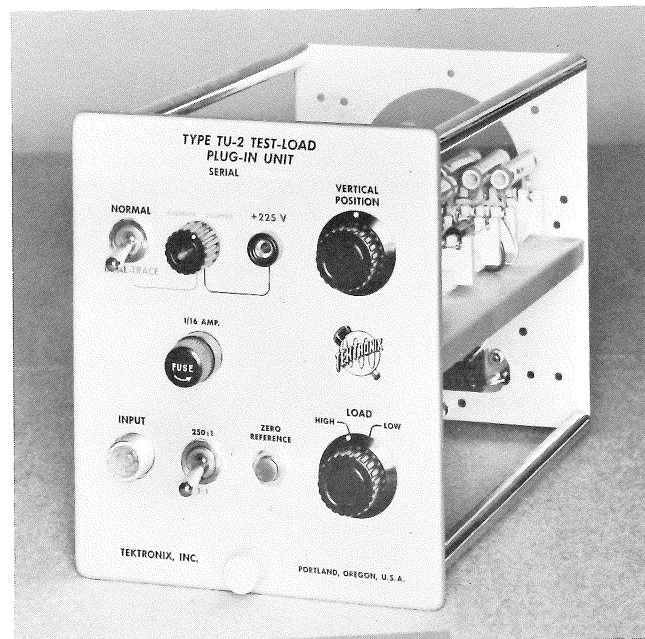

be used to check vertical amplifier balance, vertical amplifier gain, and dual-trace function of the oscilloscope. It eliminates the need to keep plug-in preamplifiers in the maintenance area to make these checks.

ORDER PART NUMBER 015-012

ATTENUATORS and TERMINATIONS

PART NO.	DESCRIPTION
011-001	52-ohm termination, 1.5 w
011-002	52-ohm 'L' attenuator, 5 to 1 voltage ratio, 1.5 w
011-003	52-ohm 'L' attenuator, 10 to 1 voltage ratio, 1.5 w
011-004	Minimum-loss termination, 52 ohms to 75 ohms
011-005	Minimum-loss termination, 52 ohms to 170 ohms
011-027	52-ohm 'T' attenuator, 5 to 1 voltage ratio, 1.5 w
011-006	52-ohm 'T' attenuator, 10 to 1 voltage ratio, 1.5 w

Dimensions—4³/₄" wide, 7³/₄" high, 9" overall depth.

Weight—6 lbs.

Includes: 1—3-conductor power cord (161-010)

Probe Power-Cable Extension—A 24" 3-conductor power-cable extension for Tektronix cathode-follower probes. Permits wider separation of the probe power source from the instrument signal input.

ORDER PART NUMBER 012-030



- 011-026 52-ohm to 170 ohm termination, 10 to 1 voltage ratio, 1.5 w
- 011-007 75-ohm termination, 1.5 w
- 011-008 75-ohm 'L' attenuator, 5 to 1 voltage ratio, 1.5 w
- 011-009 75-ohm 'L' attenuator, 10 to 1 voltage ratio, 1.5 w
- 011-010 75-ohm 'T' attenuator, 10 to 1 voltage ratio, 1.5 w
- 011-011 93-ohm termination, 1.5 w
- 011-012 93-ohm 'L' attenuator, 5 to 1 voltage ratio, 1.5 w
- 011-013 93-ohm 'L' attenuator, 10 to 1 voltage ratio, 1.5 w
- 011-014 Minimum-loss termination, 93 ohms to 52 ohms, 1.5 w
- 011-015 93-ohm 'T' attenuator, 10 to 1 voltage ratio, 1.5 w
- 011-016 170-ohm termination, 0.5 w

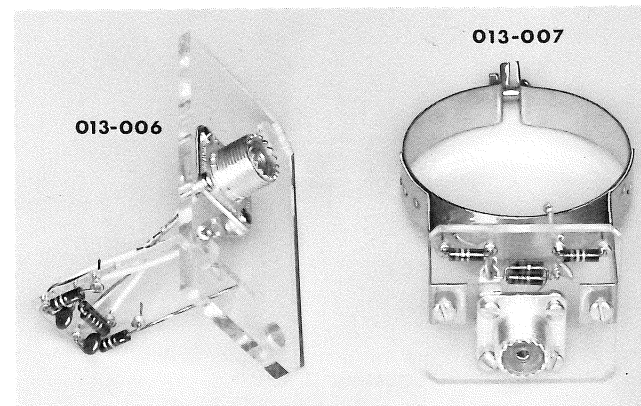

Deflection Plate Connectors—For Type 530, 540, 530A, and 540A-Series Oscilloscopes. A convenient means of making a connection directly to the cathode-ray tube vertical deflection plates to realize the maximum frequency response of the crt. Designed for use with high-frequency, fast-rise pulses or transient signals. Under these conditions

the function of the vertical position control of the oscilloscope is retained. The connectors are designed for use with 52-ohm cables. The connectors are not recommended for use with frequencies below 8 kc or pulses with correspondingly slow risetimes.

For instruments with serial number below 5001,
ORDER PART NUMBER 013-006

For instruments with serial numbers 5001 and above,
ORDER PART NUMBER 013-007

INTERCONNECTING CABLES

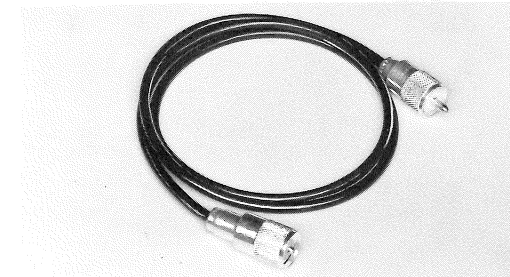

- 52-ohms nominal impedance, 42 inches long.
ORDER PART NUMBER 012-001
- 75-ohms nominal impedance, 42 inches long.
ORDER PART NUMBER 012-002
- 93-ohms nominal impedance, 42 inches long.
ORDER PART NUMBER 012-003
- 93-ohms, 42 inches long, terminated with variable attenuator.
ORDER PART NUMBER 012-004
- 93-ohms, 42 inches long, terminated with 1/2 watt 93 ohm resistor.
ORDER PART NUMBER 012-005
- 170-ohms nominal impedance, 42 inches long.
ORDER PART NUMBER 012-006

ADAPTERS

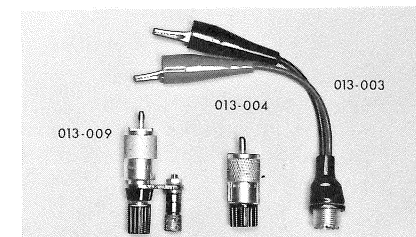

- 013-003 Adapter, clip lead
- 013-004 Adapter, binding post
- 013-009 Binding Post Adapter with ground terminal, 3/4" spacing

STANDARDIZERS

47 pf Input Capacitance Standardizer—For use with Type A to Z Plug-In Preamplifiers having an input capacitance of 47 pf. With this accessory the input capacitance of each preamplifier can be standardized to 47 pf.
ORDER PART NUMBER 011-021

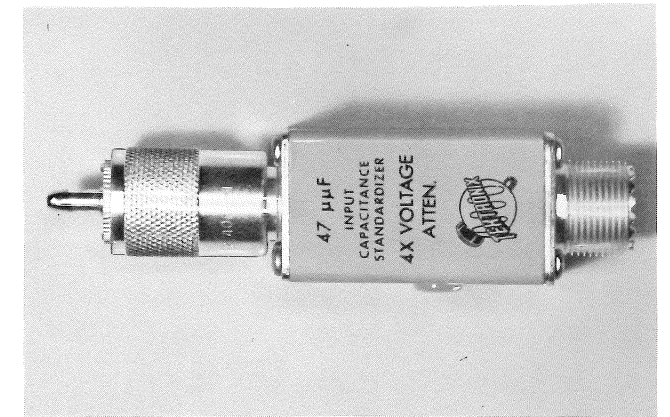

20 pf Input Capacitance Standardizer—Similar to 011-021 for use with the Types CA, K and L Plug-In Preamplifiers having 20 pf input capacitance.

ORDER PART NUMBER 011-022

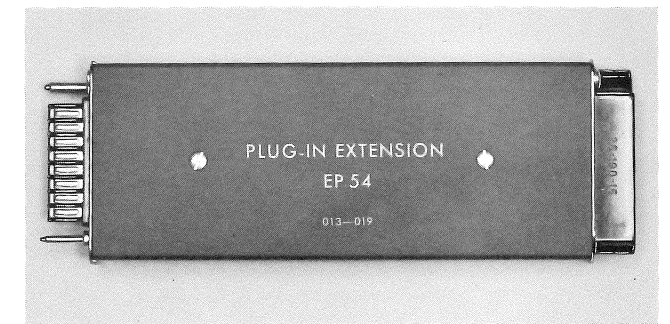

Plug-in Extension—Six inches long and allows the plug-in preamplifier unit for the Type 530, 530A, 540, 540A-Series Oscilloscopes to be operated partially out of its housing.

ORDER PART NUMBER 013-019

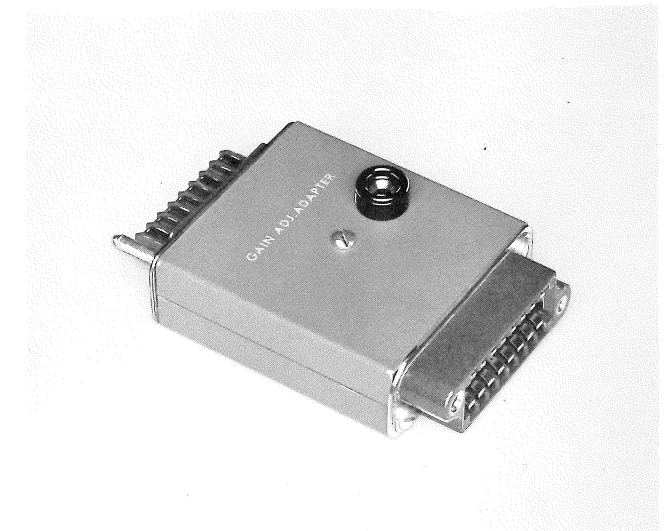

Gain Adjust Adapter—Permits an external calibrating signal to bypass the plug-in preamplifier, for calibrating the sensitivity of the main amplifier of Type 530, 530A, 540, 540A-Series Oscilloscopes.

ORDER PART NUMBER 013-005

MISCELLANEOUS ACCESSORIES

SCOPEMOBILES



TYPE 500/53A

The Tektronix Type 500/53A Scope-Mobile is a sturdy, mobile support for Tektronix 5" Oscilloscopes. Convenient observation of the crt face is achieved by a 20-degree backward tilt of the top surface. The front panel has two supporting cradles to accommodate Tektronix Pre-amplifier Plug-In units. A drawer, felt-lined and operating on roller bearings, provides handy storage for probes, cables, manuals etc. An open shelf, 14⁵/₈" wide, 12¹/₂" high, and 23⁵/₈" deep, topped with tough linoleum, is located at the bottom. Power input and three convenience outlets are mounted at the rear. Total weight is 35 pounds. Dimensions are 17³/₄" wide, 38" high and 27" deep. Space requirements for height and depth will vary with the type of instrument being used.

Includes: 1—3-conductor power cord (161-014)

Scope-Mobile Panel—for Type 500A Scope-Mobiles. Converts the Type 500A to a Type 500/53A by replacing the standard blank panel.

ORDER PART NUMBER 014-005



TYPE 500A

The Tektronix Type 500A Scope-Mobile is identical to the Type 500/53A, except for the front panel. Auxiliary equipment can be mounted behind the blank front panel in a space 13³/₄" wide, and 8¹/₂" high for the first 5¹/₂" of depth and tapering in height from this point, on a 20 degree angle

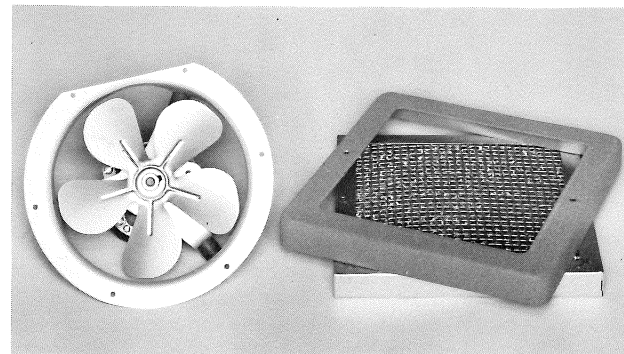

Scopemobile fan kit

to a minimum height of 2¹/₂" at a depth of 19¹/₂". It will usually be necessary to provide forced-air ventilation for the equipment compartment. A fan kit, 040-161, is recommended for this purpose.

Includes: 1—3-conductor power cord (161-014)

Scope-Mobile Panel—For Type 500 Scope-Mobiles only. Converts the earlier Type 500 model to a Type 500/53 by replacing the standard blank panel.

ORDER PART NUMBER 014-004

Scope-Mobile Fan Kit—for forced-air ventilation of the equipment compartment of the Type 500A Scope-Mobile. Provides an air flow of 84 cfm with the Scope-Mobile drawer in place. With the drawer removed and a panel covering the drawer opening, the air flow is increased to 94 cfm. Contains motor, 5" blade, filter and mounting hardware.

ORDER PART NUMBER 040-161

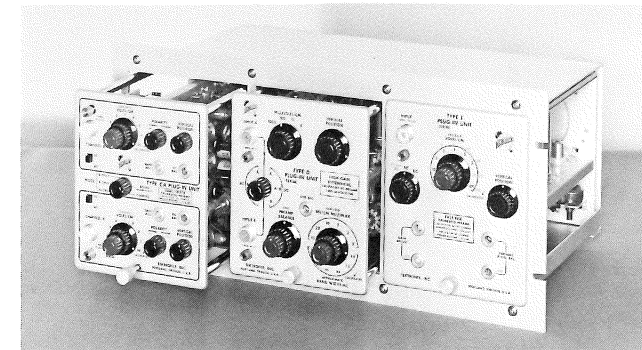

Plug-In Pre-amplifier Storage Cabinet—Mounts in standard rack, holds three Tektronix Plug-In Pre-amplifiers. Dimensions: 19" wide, 8³/₄" high, 9³/₈" deep.

ORDER PART NUMBER 437-031

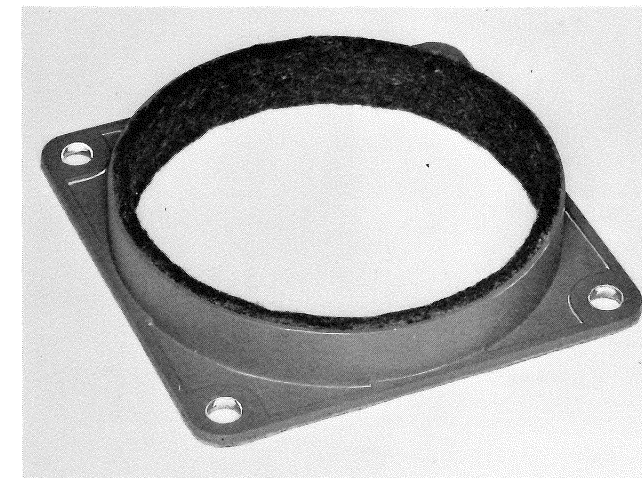

Bezel—For mounting camera on Tektronix 5" oscilloscopes. Dimensions—5⁷/₈" square; ring ⁷/₈" deep, diameter 5⁵/₈" outside, 5¹/₈" inside. Die-cast construction, wrinkle finish, felt lined.

ORDER PART NUMBER 014-001

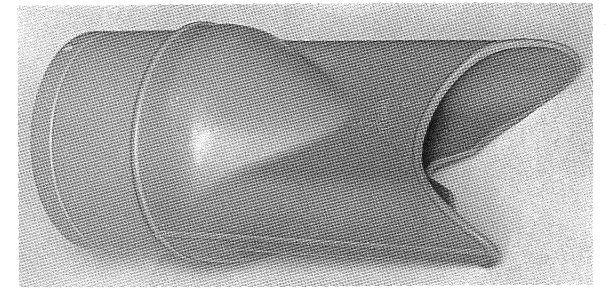

Viewing Hood—For Tektronix 5" Oscilloscopes. Includes molded rubber eye-piece and aluminum light shield.

ORDER PART NUMBER 016-001

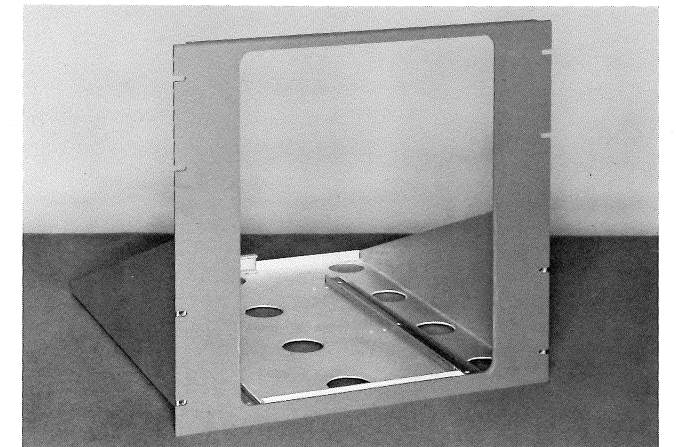

Cradle-Mount—For rack mounting cabinet-type oscilloscopes. Each cradle-mount consists of a cradle (or "shelf") to support the instrument in any standard 19" relay rack, and a mask to fit over the regular instrument panel. Tek blue wrinkle finish.

For Type 530-series, Type 540-series with serial numbers above 5000, Type 530A-series, Type 540A-series all serial numbers.

ORDER PART NUMBER 040-182

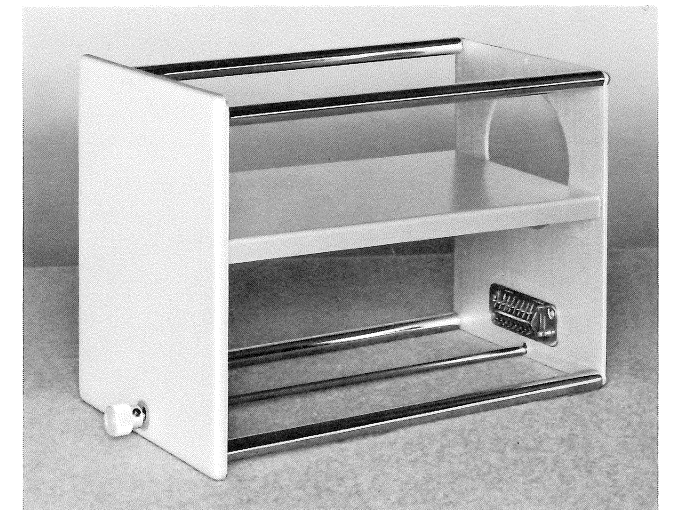

Blank Plug-In Skeleton

ORDER PART NUMBER 040-065

PARTS LIST *and* DIAGRAMS

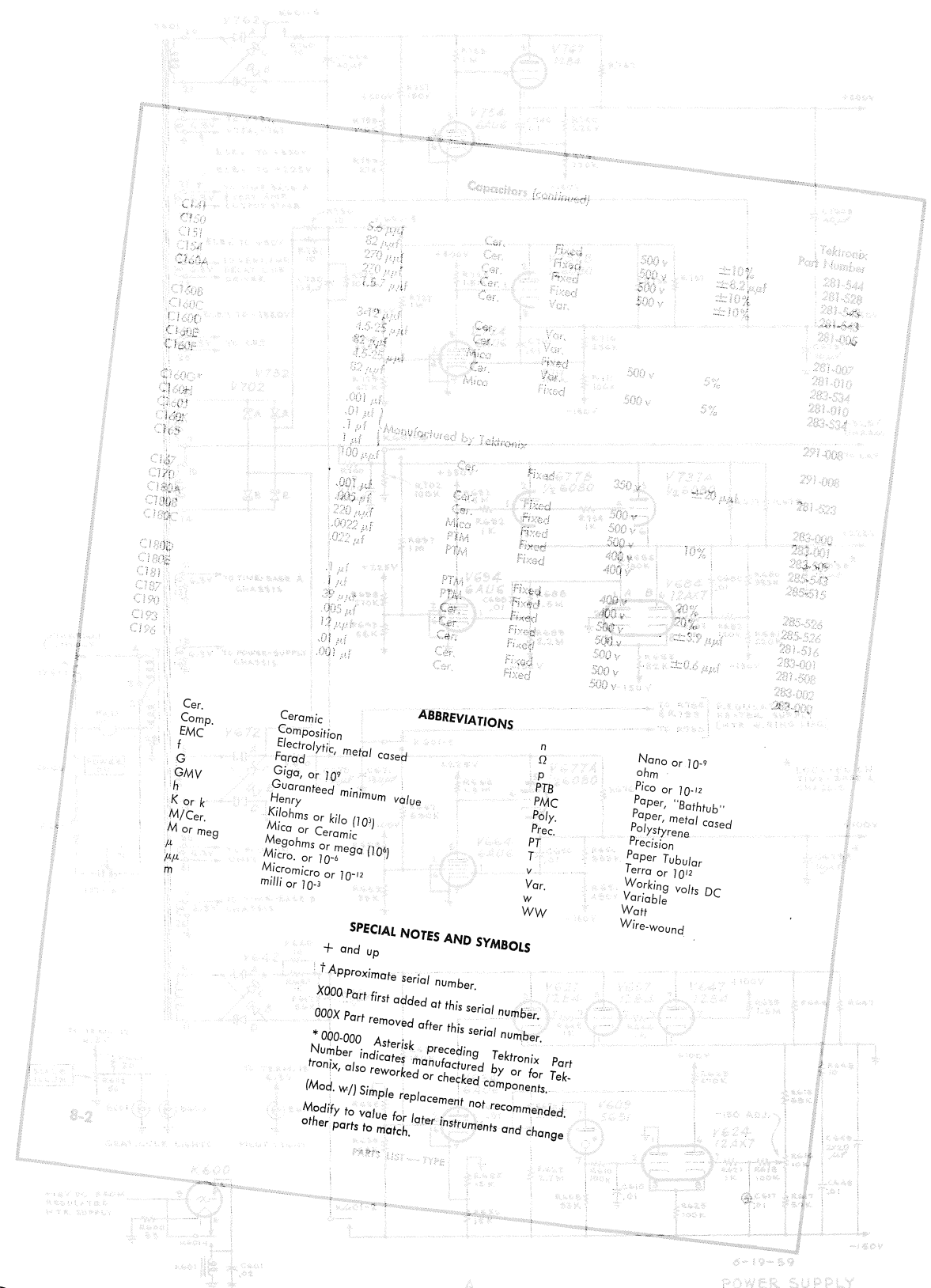

ABBREVIATIONS

Cer.	Ceramic	n	Nano or 10 ⁻⁹
Comp.	Composition	Ω	ohm
EMC	Electrolytic, metal cased	p	Pico or 10 ⁻¹²
f	Farad	PTB	Paper, "Bathtub"
G	Giga, or 10 ⁹	PMC	Paper, metal cased
GMV	Guaranteed minimum value	Poly.	Polystyrene
h	Henry	Prec.	Precision
K or k	Kilohms or kilo (10 ³)	PT	Paper Tubular
M/Cer.	Mica or Ceramic	T	Terra or 10 ¹²
M or meg	Megohms or mega (10 ⁶)	v	Working volts DC
μ	Micro, or 10 ⁻⁶	Var.	Variable
μ m	Micromicro or 10 ⁻¹²	w	Watt
m	milli or 10 ⁻³	WW	Wire-wound

SPECIAL NOTES AND SYMBOLS

+ and up

† Approximate serial number.

X000 Part first added at this serial number.

000X Part removed after this serial number.

* 000-000 Asterisk preceding Tektronix Part Number indicates manufactured by or for Tektronix, also reworked or checked components.

(Mod. w/) Simple replacement not recommended. Modify to value for later instruments and change other parts to match.



MANUFACTURERS OF CATHODE-RAY OSCILLOSCOPES

SPECIAL TYPE RM32 INFORMATION

HOW TO ORDER PARTS

Replacement parts are available through your local Tektronix Field Office.

Improvements in Tektronix instruments are incorporated as soon as available. Therefore, when ordering a replacement part it is important to supply the part number including any suffix, instrument type, serial number, plus a modification number where applicable.

If the part you have ordered has been improved or replaced, your local Field Office will contact you if there is a change in part number.

General Information

The oscilloscope for which this manual was prepared is a standard Type 532 specially modified for rack mounting. Electrically, the instrument is in every way identical with the standard Type 532. All information in the manual concerning circuit descriptions, operation, maintenance and recalibration apply equally to the Type RM32. Front panel controls are located in exactly the same place with respect to each other. The silk-screened control descriptions on the front panel have merely been rotated 90° left so that the instrument may be operated in the rack-mount position with the longest dimension in a horizontal plane. Parts list and circuit diagrams are also equally applicable to either the "upright" or rack-mounted instruments.

Rack-Mounting Procedure

The Type RM32 comes to you ready for quick and easy permanent mounting in a standard relay rack. Installation of only four mounting screws will give a solid installation with easy accessibility to all parts of the instrument. In selecting a location for mounting, it is well to allow for 3 1/2 to 4 feet of clearance on the front of the rack to permit extending of the instrument fully out of the cabinet for maintenance or operational purposes. This will permit tilting the oscilloscope up or down in the Chassis-Traks, and still allow working room in front. The Type RM32 cabinet extends 21 and three-quarter inches from the face of the rack to the back of the air filter when the instrument is fully engaged within the cabinet and locked in place. It is also necessary to allow additional clearance to the rear for purposes of air circulation. The Type RM32 is cooled by a fan at the rear of the instrument, and sufficient air circulation is an absolute necessity for protection of operating components within the oscilloscope.

To mount the Type RM32 cabinet in a rack, first remove the oscilloscope from the cabinet. This is done by first releasing the four locking screws at the corners of the front panel, then merely sliding the instrument out as far as it will go and pressing the slide release buttons to disengage the Chassis-Trak brackets on either side.

Next, select the height on the rack where you want the top of the cabinet to come. Then measure down one and seven-sixteenths inches on each side of the rack. This will be the location for the center of the top mounting screw. Center-to-center measurement from this point down to the lower mounting screw holes is exactly 11 inches. After holes for mounting screws are properly located, hold the cabinet in place behind the rack and mount the screws. If your relay rack does not provide for support of the Type RM32 cabinet at the rear, it may be advisable to use more than four mounting screws for additional support and rigidity.

After the cabinet is mounted and firmly anchored into the relay rack, it is merely necessary to re-mount the instrument within the Chassis-Traks and slide it back into the cabinet. When the locking screws on the front panel are tightened, your oscilloscope should be ready for operation as soon as power is supplied.

The Chassis-Traks are properly mounted with the Type RM32 cabinet at the factory. It should not be necessary for you to change their adjustments within the cabinet.

Operation

It may sometimes be desirable or necessary to operate your Type RM32 in an extended position outside the cabinet. To do so, it will be necessary to plug in a 3-wire-power cord between the cabinet power outlet and the

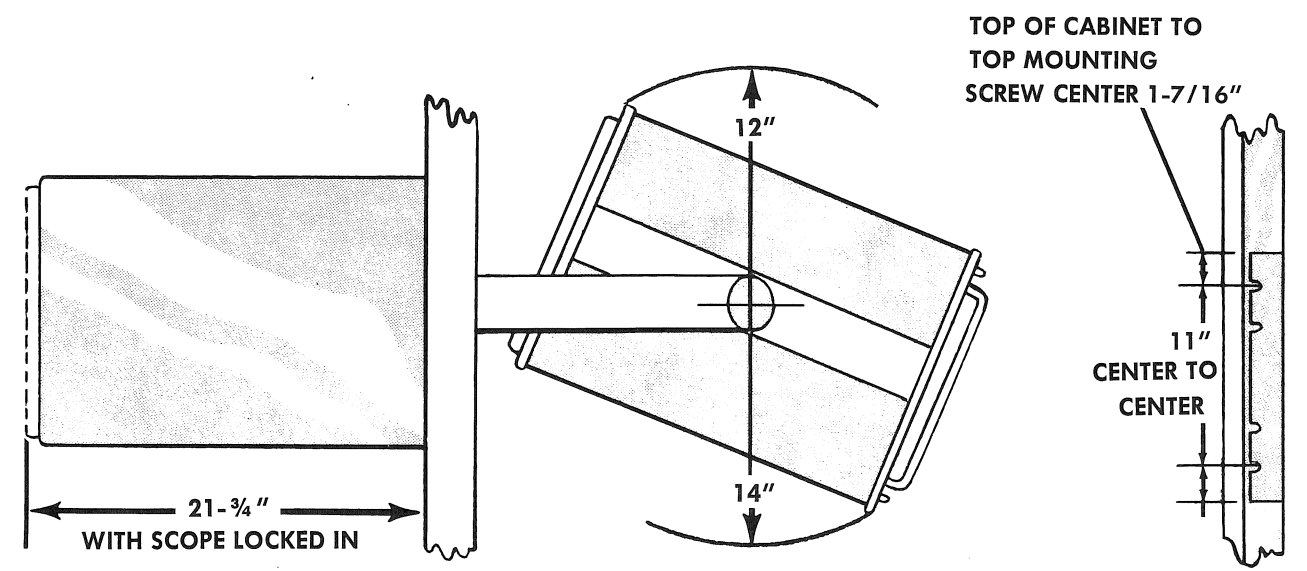
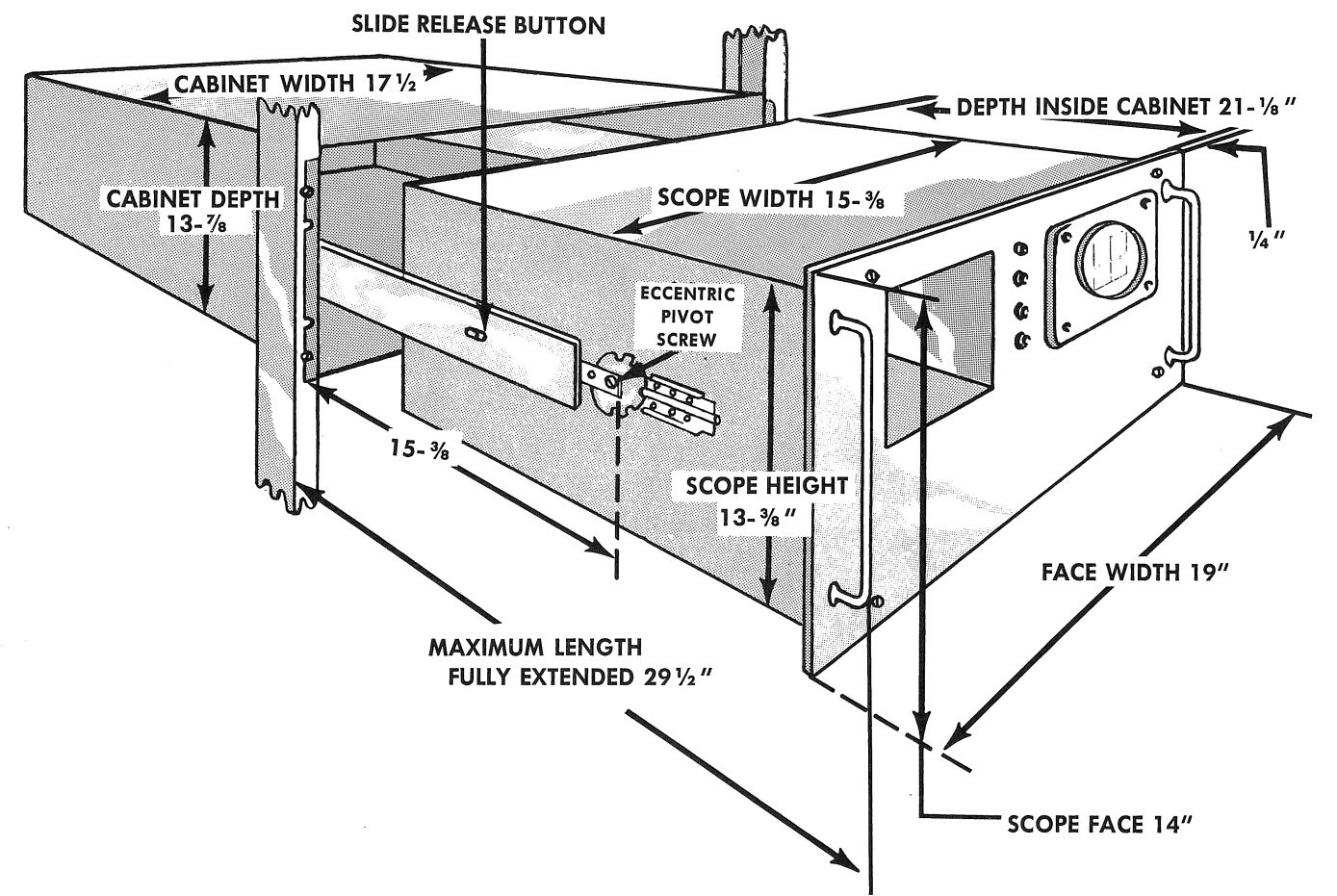
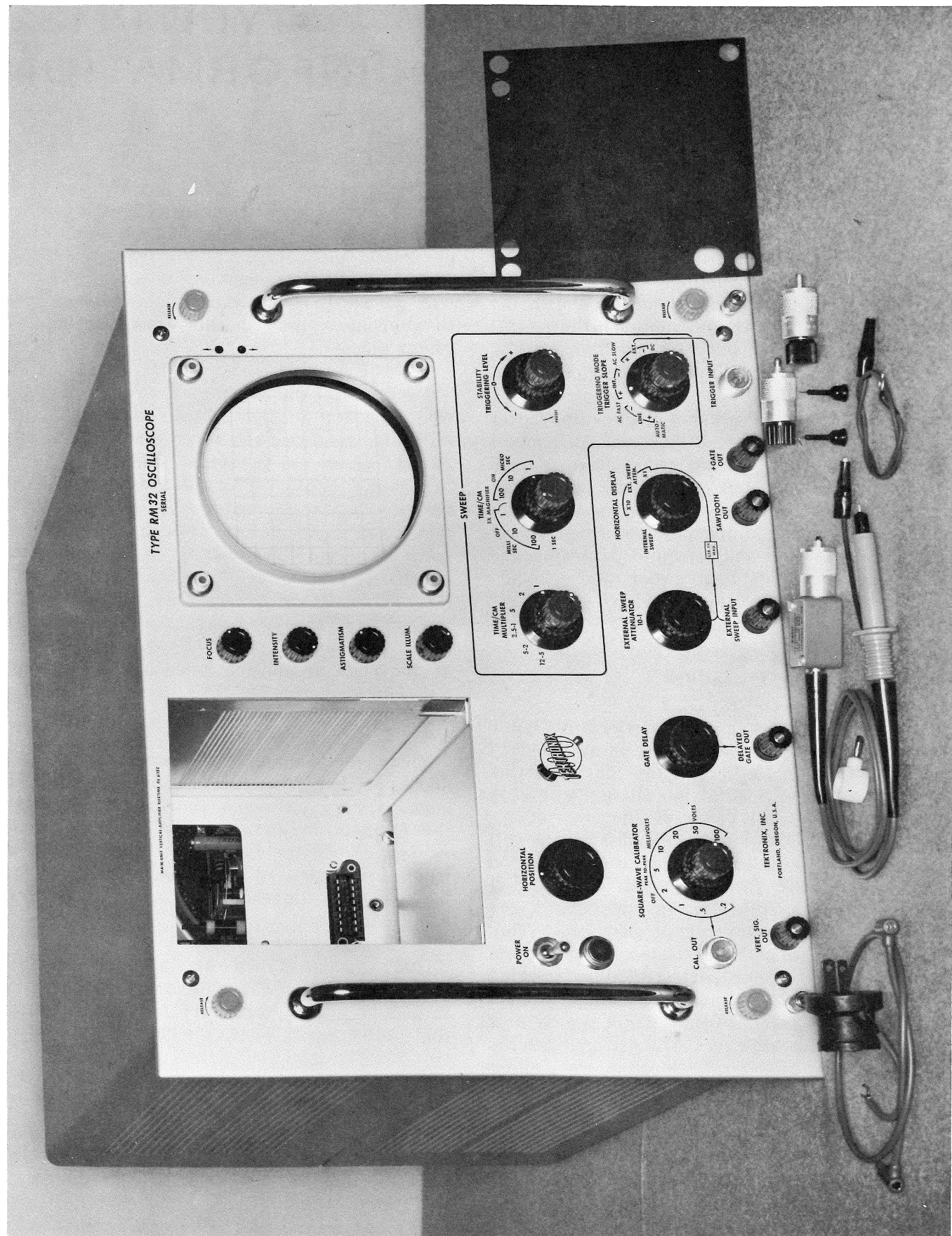

Special Information - Type RM32

instrument proper. Be sure that this cord is long enough to allow for extending the instrument all the way out of the cabinet, and for any tilting upward or downward. The added power cord can easily be installed from the rear when the instrument is extended.

Modification Information

From time to time, Tektronix Oscilloscopes are modified by changing or adding circuit

components for the purpose of improving their performance and reliability. Your instruction manual indicates these changes in the Parts List and Circuit Diagrams where applicable, showing the Serial Numbers at which changes have occurred. While the same improvements are added to your rack-mounting instruments as to standard scopes, they generally occur at different Serial Numbers. These Serial Number changes are hand-corrected in red ink in your Instruction Manual.

TYPE 532, TENT. S/N 7170
TYPE RM 32, TENT. S/N 500
MOD. 5224

This instrument has been modified to eliminate selecting of Vertical Position indication neon bulbs.

PARTS LIST

R163	ADD	820K	1/2w	10%	comp	302-824
------	-----	------	------	-----	------	---------

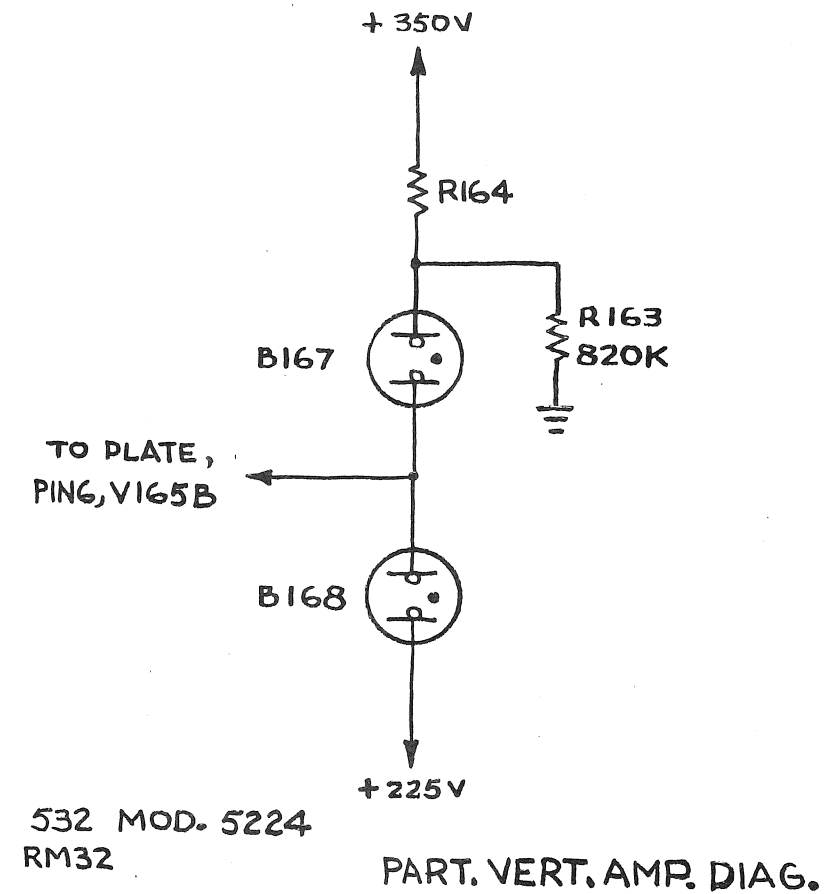

TYPE 532 Tent. S/N 7168
TYPE RM532 Tent. S/N 490
Mod. 5068

This instrument has been modified to reduce sweep length shortening
with trigger variations.

PARTS LIST

D426	Add	T12G	152-008
------	-----	------	---------

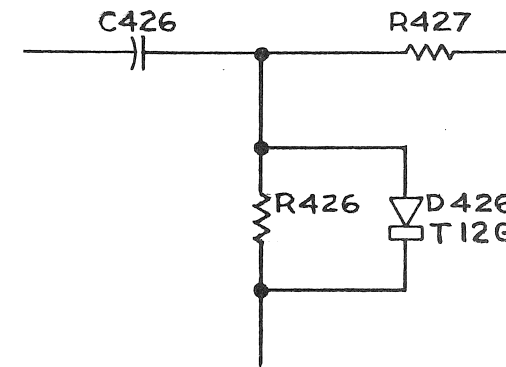

MI
PART. SWP. DIAG.
12-11-61

PARTS LIST

Bulbs

					Tektronix Part Number
B167	101-491 492-up	Neon, NE-2	Selected	65-75 v ignition voltage	*150-014 150-002
B168	101-491 492-up	Neon, NE-2	Selected	65-75 v ignition voltage	*150-014 150-002
B475	101-5676 5677-up	Neon, NE-2	Selected	60 v drop	*150-010 150-002
B485	101-264 265-5676 5677-up	Neon, NE-2	Selected	60 v drop	*150-010
		Neon, NE-2	Selected	55 v drop	*150-009
B604		Incandescent, #47			150-001
B605		Incandescent, #47			150-001
B606		Incandescent, #47			150-001

Capacitors

Values fixed unless marked variable.

Tolerance $\pm 20\%$ unless otherwise indicated.

C105		.001 μf	Cer.	500 v	GMV	283-000
C106		.001 μf	Cer.	500 v	GMV	283-000
C110	X6950-up	6.25 μf	EMT	300 v		290-025
C113	X5798-up	6.25 μf	EMC	300 v	-20+50%	290-000
C114	X419-up	.047 μf	PTM	600 v	10%	285-520
C161		6.25 μf	EMC	300 v	-20+50%	290-000
C162	101-5744 5745-up	6.25 μf	EMC	300 v	-20+50%	290-000
C175	101-418 419-up	.01 μf	Cer.	500 v		283-002
		1.5 pf	Cer.	500 v	$\pm .5$ pf	281-526
C185	X419-up	.7-3 pf	Cer.	500 v		281-027
		22 pf	Cer.	500 v		281-510
C207		330 pf	Mica	500 v	10%	283-518
C210		330 pf	Mica	500 v	10%	283-518
C230		27 pf	Cer.	500 v	10%	281-512
C246		.001 μf	Cer.	500 v	GMV	283-000
C303		.001 μf	PT	600 v		285-501
C304		100 pf	Cer.	350 v		281-523
C307		.001 μf	Cer.	500 v	GMV	283-000
C317		.001 μf	Cer.	500 v	GMV	283-000
C320		.01 μf	Cer.	500 v	GMV	283-002
C328		.005 μf	Cer.	500 v	GMV	283-001
C334		22 pf	Cer.	500 v		281-510
C406		.001 μf	Cer.	500 v	GMV	283-000
C420A		.22 μf	PT	400 v		285-533
C420B		.022 μf	PT	400 v		285-515
C420C		.0022 μf	PT	400 v		285-543
C420D		220 pf	Mica	500 v	10%	283-536
C421		39 pf	Cer.	500 v	10%	281-516
C426	101-132 133-up	47 pf	Cer.	500 v		281-518
		22 pf	Cer.	500 v		281-510
C430		8 pf	Cer.	500 v	$\pm .5$ pf	281-503

Capacitors (continued)

Part Number	Value	Material	Voltage	Tolerance	Tektronix Part Number
C432	12 pf	Cer.	500 v	10%	281-506
C446	12 pf	Cer.	500 v	10%	281-506
C457	82 pf	Cer.	500 v	10%	281-528
C465	.001 μ f	Cer.	500 v	GMV	283-000
C470	.001 μ f	Cer.	500 v	GMV	283-000
C487	.001 μ f	Cer.	500 v	GMV	283-000
C490A	1 μ f	Mylar Timing Series			*291-007
C490B	.1 μ f				
C490C	.01 μ f				
C490D	.001 μ f				
C490E	82 pf				
C490F	4.5-25 pf	Cer.	500 v		281-010
C490G	3-12 pf	Cer.	500 v		281-007
C501	.001 μ f	Cer.	500 v	GMV	283-000
C505	7-45 pf	Cer.	500 v		281-012
C506	220 pf	Mica	500 v	5%	283-513
C515	3 x 10 μ f	EMC	450 v		290-033
C523	15 pf	Cer.	500 v	10%	281-509
C524	22 pf	Cer.	500 v		281-510
C533	12 pf	Cer.	500 v	10%	281-506
C539	.01 μ f	Cer.	500 v	GMV	283-002
C546	3-12 pf	Cer.	500 v		281-007
C547	27 pf	Cer.	500 v		281-515
C548	39 pf	Cer.	500 v	10%	281-517
C548	7-45 pf	Cer.	500 v		281-012
C554	.005 μ f	Cer.	500 v	GMV	283-001
C555	8 pf	Cer.	500 v	\pm .5 pf	281-503
C561	1.5-7 pf	Cer.	500 v		281-005
C568	7-45 pf	Cer.	500 v		281-012
C569	22 pf	Cer.	500 v		281-510
C575	1.5 pf	Cer.	500 v	\pm .5 pf	281-526
C588	.01 μ f	PT	500 v		285-510
C605	2 x 40 μ f	EMC	450 v		290-042
C625	.01 μ f	PT	400 v		285-510
C630	.01 μ f	PT	400 v		285-510
C637	.01 μ f	PT	400 v		285-510
C640	2 x 20 μ f	EMC	450 v		290-036
C643	125 μ f	EMC	350 v		290-052
C654	.01 μ f	PT	400 v		285-510
C662	2x40 μ f	EMC	450 v		290-043
C675	.01 μ f	PT	400 v		285-510
C682	.01 μ f	PT	400 v		285-510
C688	2x40 μ f	EMC	450 v		290-042
C697	.01 μ f	PT	400 v		Use 285-511
C697	.01 μ f	PT	600 v		285-511

Capacitors (continued)

Part Number	Value	Material	Voltage	Tolerance	Tektronix Part Number
C803	.001 μ f	PT	600 v		285-501
C805	.01 μ f	PT	400 v		285-510
C806	.001 μ f	PT	600 v		285-501
C807	2x20 μ f	EMC	450 v		290-037
C813	.01 μ f	Cer.	500 v	GMV	283-002
C814	.0068 μ f	PT	3000 v		285-508
C820	.01 μ f	PT	3000 v		283-011
C821	.0068 μ f	PT	3000 v		285-508
C821	.01 μ f	PT	3000 v		283-011
C821	.005 /f	Cer.	4000 v		Use 283-034
C830	.0068 μ f	PT	3000 v		285-508
C832	.01 μ f	PT	3000 v		283-011
C832	.015 μ f	PT	3000 v		285-513
C832	.01 μ f	Cer.	2000 v		283-011
C834	.015 μ f	PT	3000 v		285-513
C834	.01 μ f	Cer.	2000 v		283-011
C835	.01 μ f	Cer.	2000 v		283-011
C855	.015 μ f	PT	3000 v		285-513
C857	.01 μ f	Cer.	2000 v		283-011
C857	.015 μ f	PT	3000 v		285-513
C857	.01 μ f	Cer.	2000 v		283-011

Diodes

Even though the diodes may be different in physical size, they are direct electrical replacements for the diodes in your instrument.

D426	Germanium Diode	152-008
D642A,B,C,D	Silicon Diode	152-047

Fuses

5 Amp 3 AG Fast-Blo Fuse 117 v Operation 60 cycle	159-014
3 Amp 3 AG Slo-Blo Fuse 234 v Operation 50 cycle	159-005
5 Amp 3 AG Slo-Blo-Fuse 117 v Operation 50 cycle	159-006
3 Amp 3 AG Fast-Blo Fuse 234 v Operation 60 cycle	159-015

Inductors

L123	19-35 μ h	Var.	*114-005
L124	19-35 μ h	Var.	*114-005
L141	5.6 μ h	Fixed	*108-064
L142	6.4 μ h	Fixed	*108-054
L142	5.6 μ h	Fixed	*108-064
L142	6.4 μ h	Fixed	*108-054
L153	82-140 μ h	Var.	*114-033
L154	53-96 μ h	Var.	*114-021
L154	82-140 μ h	Var.	*114-033
L154	53-96 μ h	Var.	*114-021
LR125	7 μ h	Fixed	*108-082
LR441	2.5 μ h	Fixed	*108-104
LR441	1500 μ h	Fixed	*108-083

Resistors

Resistors are fixed, comp., \pm 10% unless otherwise indicated.

R1	47 Ω	1/2 w	302-470
R110	100 Ω	1/2 w	302-101
R111	100 Ω	1/2 w	302-101
R112	100 Ω	1/2 w	302-101
R113	100 Ω	1/2 w	302-101
R114	100 Ω	1/2 w	302-101

Resistors (continued)

Resistor	Part Number	Value	Power	Notes	Tolerance	Tektronix Part Number
R116	101-418	33 k	2 w			306-333
	419-up	15 k	10 w			308-024
R120	X419-up	100 Ω	2 w	Var.	5% Amp. Bal	311-003
R121		1.5 k	1/2 w		5%	301-152
R122		1.5 k	1/2 w		5%	301-152
R123	101-418	2.7 k	1/2 w			302-272
	419-up	33 k	1/2 w			302-333
R124	101-418	2.7 k	1/2 w			302-272
	419-up	3.9 k	1/2 w			302-392
R126	101-418	4.7 k	1/2 w			302-472
	419-up	8.2 k	1 w			304-822
R131		100 Ω	1/2 w			302-101
R132		100 Ω	1/2 w			302-101
R133	101-418	33 k	1 w			304-333
	419-up	18 k	2 w			306-183
R134	101-418	33 k	1 w			304-333
	419-up	18 k	2 w			306-183
R141		47 Ω	1/2 w			302-470
R142		47 Ω	1/2 w			302-470
R143		1 k	1/2 w			302-102
R144		1 k	1/2 w			302-102
R145		2.5 k	10 w		5% WW	308-018
R146		200 Ω	2 w	Var.	Gain Adjust	311-004
R150	101-418	3.9 k	1 w			304-392
	419-up	8.2 k	1 w			304-822
R153	101-6324	5 k	5 w		1% Mica Plate	*310-511
	6325-up	4 k	5 w		1% Mica Plate	*310-508
R154	101-6324	5 k	5 w		1% Mica Plate	*310-511
	6325-up	4 k	5 w		1% Mica Plate	*310-508
R156	101-6324	2.5 k	10 w		5% WW	308-018
	6325-up	3 k	10 w		5% WW	308-020
R161		180 k	1/2 w			302-184
R162	101-5744	180 k	1/2 w			302-184
	5745-up	22 meg	1/2 w			302-226
R164	101-418	220 k	1/2 w			302-224
	419-up	47 k	1/2 w			302-473
R165	X419-up	68 k	1/2 w			302-683
R166	X419-up	2.2 meg	1/2 w			302-225
R167	101-418	100 k	1/2 w			302-104
	419-5744	5.6 k	1/2 w			302-562
	5745-up	8.2 k	1/2 w			302-822
R168	101-418	100 k	1/2 w			302-104
	419-5744	47 k	1/2 w			302-473
	5745-up	22 k	1 w			304-223
R169	101-418X	220 k	1/2 w			302-224
R170	101-418X	220 k	1/2 w			302-224
R175	101-418	820 k	1/2 w		5%	301-824
	419-up	820 k	1/2 w			302-824
R176	101-418	560 k	1/2 w		5%	301-564
	419-up	470 k	1/2 w			302-474
R177	101-418	470 k	1/2 w		5%	301-474
	419-up	470 k	1/2 w			302-474

Resistors (continued)

Resistor	Part Number	Value	Power	Notes	Tolerance	Tektronix Part Number
R178	X419-5310	39 k	1 w			304-393
	5311-up	27 k	1 w			304-273
R179	X419-5310	10 k	2 w	Var.		311-016
	5311-up	20 k	2 w	Var.	Int. Trig. DC LEVEL ADJ.	311-018
R180	X419-up	100 Ω	1/2 w			302-101
R185	X419-up	2.7 k	1/2 w			302-272
R186	X419-up	150 k	1/2 w			302-154
R188	X419-up	100 Ω	1/2 w			302-101
R190	X419-up	27 k	2 w			306-273
R205		150 k	1/2 w			302-154
R206		1 k	1/2 w			302-102
R207		3.3 meg	1/2 w			302-335
R210		2.7 meg	1/2 w			302-275
R211		1 k	1/2 w			302-102
R215		68 k	1/2 w			302-683
R217		33 k	1 w			304-333
R218		10 k	2 w	Var.	Cal. Adj.	311-016
R219		100 k	1/2 w			302-104
R225		1.5 meg	1/2 w			302-155
R226		100 Ω	1/2 w			302-101
R231		9.5 k	1/2 w		Prec. 1%	309-121
R232		6.375 k	1/2 w		Prec. 1%	309-119
R233		2.1 k	1/2 w		Prec. 1%	309-117
R234		1.025 k	1/2 w		Prec. 1%	309-116
R235		610 Ω	1/2 w		Prec. 1%	309-113
R236		200 Ω	1/2 w		Prec. 1%	309-073
R237		100 Ω	1/2 w		Prec. 1%	309-112
R238		60 Ω	1/2 w		Prec. 1%	309-067
R239		40 Ω	1/2 w		Prec. 1%	309-066
R245		100 k	1/2 w		Prec. 1%	309-045
R246		100 Ω	1/2 w		Prec. 1%	309-112
R249	X5001-up	.25 Ω	1 w		WW	*308-090
R250		100 Ω	1/2 w			302-101
R302		27 k	2 w			306-473
R305		1 meg	1/2 w			302-105
R306		100 k	1/2 w			302-104
R307		470 k	1/2 w			302-474
R308		100 Ω	1/2 w			302-101
R310		8.2 k	1/2 w			302-822
R311		100 Ω	1/2 w			302-101
R312		27 k	2 w			306-273
R314	*101-5665	100 k	2 w	Var.	Trig. Level	311-030
	**5666-up	100 k	2 w	Var.	Trig. Level	311-096
R315		22 k	1/2 w			302-223
R316		470 k	1/2 w			302-474
R317		470 k	1/2 w			302-474
R319		56 k	1/2 w			302-563
R320		47 k	1/2 w			302-473
R321		47 k	1/2 w			302-473
R322		100 Ω	1/2 w			302-101

*Furnished as a unit with R405.

**Furnished as a unit with R405 & SW405.

Resistors (continued)

Part Number	Value	Power	Tolerance	Notes	Tektronix Part Number
R323	101-150	3.3 k	1/2 w		302-332
	151-up	1.8 k	1/2 w		301-182
R324	101-150	6.8 k	1/2 w	5%	302-682
	151-167	4.7 k	1/2 w		302-472
	168-up	3.9 k	1/2 w		302-392
R327		33 k	1 w		304-333
R328	101-6339	500 Ω	2 w	Var.	Use 311-006
	6340-up	1 k	2 w	Var.	311-006
R329		33 k	1 w		304-333
R330		2.7 meg	1/2 w		302-275
R332		2.2 k	1/2 w		302-222
R333		100 Ω	1/2 w		302-101
R334		100 k	1/2 w		302-104
R335	101-150	47 k	1/2 w		302-473
	151-up	120 k	1/2 w		302-124
R336		100 k	2 w	Var.	Trig. Level Cent. 311-026
R404	X5420-up	100 k	2 w	Var.	Preset Stability 311-026
R405	*101-5665	100 k	2 w	Var.	Stability 311-030
	**5666-up	100 k	2 w	Var.	Stability 311-096
R406		1 meg	1/2 w		302-105
R408		270 k	1/2 w		302-274
R409		470 k	1/2 w		302-474
R415		22 k	2 w		306-223
R416		100 Ω	1/2 w		302-101
R420A		4.7 meg	1/2 w		302-475
R420B	X133-up	1.8 meg	1/2 w		302-185
R422		4.7 meg	1/2 w		302-475
R426		2.2 k	1/2 w		302-222
R427		100 Ω	1/2 w		302-101
R429	101-150	5.6 k	1/2 w		Use 301-562
	151-up	5.6 k	1/2 w	5%	301-562
R430	101-150	4.7 k	1/2 w		Use 301-472
	151-up	4.7 k	1/2 w	5%	301-472
R431		100 Ω	1/2 w		302-101
R432	101-150	39 k	1 w		Use 303-393
	151-up	39 k	1 w	5%	303-393
R433	101-150	33 k	1 w		Use 303 333
	151-up	33 k	1 w	5%	303-333
R438	101-150	15 k	2 w		Use 305-153
	151-up	15 k	2 w	5%	305-153
R440		100 Ω	1/2 w		302-101
R446		47 k	1/2 w		302-473
R447	101-150	100 k	1/2 w		302-104
	151-up	82 k	1/2 w		302-823
R452		100 Ω	1/2 w		302-101
R453	101-150	10 k	1/2 w		302-103
	151-up	4.7 k	1/2 w		302-472

*Furnished as a unit with R314.

**Furnished as a unit with R314 & SW405.

Resistors (continued)

Part Number	Value	Power	Tolerance	Notes	Tektronix Part Number
R455		2.2 k	1/2 w		302-222
R456		47 k	1/2 w		302-473
R457	X419-up	680 Ω	1/2 w		302-681
R466	101-6304	47 k	1/2 w		Use 301-363
	6305-up	36 k	1/2 w	5%	301-363
R467		1 meg	1/2 w		302-105
R468		10 k	1/2 w		302-103
R470		100 Ω	1/2 w		302-101
R471		1 meg	1/2 w		302-105
R472		1.8 meg	1/2 w		302-185
R475		100 Ω	1/2 w		302-101
R478	101-418	22 k	1 w		304-223
	419-up	18 k	2 w		306-183
R479		5 k	2 w	Var.	Sweep Length 311-011
R480		10 k	1 w		304-103
R485		120 k	2 w		306-124
R486		4.7 k	1/2 w		302-472
R487		1.5 meg	1/2 w		302-155
R488		100 Ω	1/2 w		302-101
R490A		30 meg	2 w	Prec.	1% 310-505
R490B		10 meg	1 w	Prec.	1% 310-107
R490C		10 meg	1 w	Prec.	1% 310-107
R490D		3 meg	1/2 w	Prec.	1% 309-026
R490E		1 meg	1/2 w	Prec.	1% 309-014
R490F		1 meg	1/2 w	Prec.	1% 309-014
R490G		10 k	1/2 w		302-103
R490H		20 k	2 w	Var.	Var. Multiplier 311-018
R501		100 k	1/2 w		302-104
R502		100 Ω	1/2 w		302-101
R503	101-225	15 k	1 w		304-153
	226-up	150 k	1 w		304-154
R505		900 k	1/2 w	Prec.	1% 309-111
R506		111 k	1/2 w	Prec.	1% 309-046
R509		1 meg	1/2 w		302-105
R510	101-6279	15 k	2 w	Var.	Ext. Swp. Att. 10-1 Use 311-112
	6280-up	15 k	2 w	Var.	311-112
R511		100 Ω	1/2 w		302-101
R513	101-6699	47 k	1 w		304-473
	6700-up	33 k	2 w		306-333
R514	101-6699	47 k	1 w		304-473
	6700-up	33 k	2 w		306-333
R515	101-6699	39 k	1 w		304-393
	6700-up	27 k	2 w		306-273
R518		4.7 k	1/2 w		302-472
R519		100 k	1/2 w		302-104
R520		250 k	2 w	Var.	Ext. Swp. Amp. DC Bal. 311-032

Resistors (continued)

Part Number	Value	Power	Prec.	Tolerance	Tektronix Part Number
R523	2 meg	1/2 w	Prec.	1%	309-023
R524	2 meg	1/2 w	Prec.	1%	309-023
R527	100 k	2 w	Var.		GATE DELAY 311-026
R528	101-418 419-443 444-up	2 meg 1.75 meg 1.5 meg	1/2 w 1/2 w 1/2 w	Prec. Prec. Prec.	309-023 309-019 309-017
R529		100 Ω	1/2 w		302-101
R530		5.6 k	1/2 w		302-562
R533		150 k	1/2 w		302-154
R534		100 k	1/2 w		302-104
R535		100 Ω	1/2 w		302-101
R536		22 k	2 w		306-223
R537	101-150 151-up	56 k 150 k	1/2 w 1/2 w		302-563 302-154
R539		470 Ω	1/2 w		302-471
R540		100 Ω	1/2 w		302-101
R541	101-150 151-up	47 k 22 k	1/2 w 1/2 w		302-473 302-223
R543	101-150 151-up	10 k 4.7 k	1/2 w 1/2 w		302-103 302-472
R546	101-418 419-up	1.75 meg 2.5 meg	1/2 w 1/2 w	Prec. Prec.	309-019 309-025
R548	101-418X	220 k	1/2 w	Prec.	309-052
R550	101-418X	3.1 meg	1/2 w	Prec.	309-027
R551	101-418X	500 k	2 w	Var.	Swp. Mag. Register 311-034
R554		50 k	2 w	Var.	HORIZ. POS. 311-023
R555	101-418 419-up	1.55 meg 1.75 meg	1/2 w 1/2 w	Prec. Prec.	309-018 309-019
R558		100 Ω	1/2 w		302-101
R560		100 k	1 w		304-104
R561	X419-up	50 k	2 w	Var.	Sweep Cal 311-023
R562	X419-up	100 k	1/2 w	Prec.	309-045
R563	101-418X	100 Ω	1/2 w		302-101
R565	101-418 419-up	40 k 780 k	5 w 1/2 w	WW Prec.	308-010 309-011
R566	X419-up	250 k	2 w	Var.	Swp. Mag. Register 311-032
R568	101-418 419-up	5 k 10 k	2 w 2 w	Var. Var.	Sweep Cal. 311-011 Mag. Cal. 311-016
R569	101-418 419-500 501-5520X	39 k 6.25 k 5 k	2 w 1/2 w 1/2 w	Prec. Prec.	306-393 309-033 309-159
R570	101-418X	39 k	2 w		306-393
R575	101-418 419-up	40 k 300 k	5 w 1/2 w	WW Prec.	308-010 309-125
R576	X419-up	183 k	1/2 w	Prec.	309-050
R577	101-418 419-up	100 Ω 100 k	1/2 w 1 w		302-101 304-104
R578	X419-up	100 Ω	1/2 w		302-101
R580	X419-up	100 Ω	1/2 w		302-101
R581	X419-up	40 k	5 w	WW	308-010
R582	X419-up	40 k	5 w	WW	308-010
R583	X419-up	100 Ω	1/2 w		302-101
R584	X419-6279 6280-up	20 k 20 k	8 w 8 w	WW WW	Use 308-081 308-081

Resistors (continued)

Part Number	Value	Power	Prec.	Tolerance	Tektronix Part Number
R587	101-418X	82 k	1/2 w	5%	301-823
R588	101-418X	22 k	1/2 w	5%	301-223
R605		10 Ω	1 w		304-100
R606		50 Ω	2 w	Var.	SCALE ILLUM. 311-055
R608		27 k	1/2 w		302-273
R609		68 k	1/2 w		302-683
R610		330 k	1/2 w		302-334
R612		15 k	1/2 w		302-153
R613		15 k	1/2 w		302-153
R615		1 meg	1/2 w		302-105
R619		1 k	1/2 w		302-102
R620		2 k	20 w	WW	5% 308-031
R625		2.7 meg	1/2 w		302-275
R626		2.7 meg	1/2 w		302-275
R630		100 k	1/2 w		302-104
R631		33 k	1/2 w		302-333
R632		100 k	1/2 w		302-104
R633	X213-up	1 k	1/2 w		302-102
R635		470 k	1/2 w		302-474
R637		1 meg	1/2 w		302-105
R638	101-448 449-up	68 k 68 k	1/2 w 1 w	Prec. Prec.	1% 1% Use 310-054 310-054
R639		10 k	2 w	Var.	-150 Adjust 311-016
R640	101-448 449-up	50 k 50 k	1/2 w 1 w	Prec. Prec.	1% 1% Use 310-086 310-086
R643		10 Ω	2 w		306-100
R645		47 k	1/2 w		302-473
R646		39 k	1/2 w	5%	301-393
R647		330 k	1/2 w		302-334
R650		1.5 meg	1/2 w		302-155
R652		47 Ω	1/2 w		302-470
R654	101-496 497-up	333 k 333 k	1/2 w 1 w	Prec. Prec.	1% 1% Use 310-056 310-056
R655	101-496 497-up	490 k 490 k	1/2 w 1 w	Prec. Prec.	1% 1% Use 310-057 310-057
R658	101-7009 7010-up	750 Ω 800 Ω	20 w 25 w	WW WW	5% 5% 308-030 308-155
R662		10 Ω	2 w		306-100
R665		270 k	1/2 w		302-274
R666		56 k	1/2 w		302-563
R668		1.5 meg	1/2 w		302-155
R670	101-124 125-167 168-5857 5858-up	2.25 k 2.4 k 3 k 3.5 k	20 w 25 w 25 w 20 w	WW WW WW WW	5% 5% 5% 5% Use 308-032 308-032 308-032 308-032 302-155
R675		1.5 meg	1/2 w		302-155
R676		2.2 meg	1/2 w		302-225
R678		180 k	1/2 w		302-184
R679		82 k	1/2 w		302-823
R680	X213-up	1 k	1/2 w		302-102
R682		2.2 meg	1/2 w		302-225

Resistors (continued)

Resistor	Value	Power	Prec.	Tektronix Part Number	Notes
R683	101-496 497-up	333 k 333 k	1/2 w 1 w	Use 310-056 310-056	
R684	101-496 497-up	220 k 220 k	1/2 w 1 w	Use 310-055 310-055	
R685		27 k	1/2 w	302-273	
R686		33 k	1/2 w	302-333	
R687		10 Ω	1/2 w	302-100	
R688		120 k	1/2 w	302-124	
R690		820 k	1/2 w	302-824	
R691		82 k	1/2 w	302-823	
R692		820 k	1/2 w	302-824	
R694		1 k	1/2 w	302-102	
R695		1.5 meg	1/2 w	302-155	
R696		6 k	20 w	308-034	WW
R697	101-496† 497-up	1.84 meg 519 k	1/2 w 1 w	309-021 310-058	Prec. 1% Prec. 1%
R698	101-496† 497-up	780 k 220 k	1/2 w 1 w	309-011 310-055	Prec. 1% Prec. 1%
R699		1 meg	1/2 w	302-105	
R800		1 k	1/2 w	302-102	
R803	101-150 151-up	47 k 33 k	2 w 2 w	306-473 306-333	
R804		47 k	1/2 w	302-473	
R805		1 k	1/2 w	302-102	
R807		390 Ω	1 w	304-391	
R810		470 k	1 w	304-474	
R811		2 meg	2 w	311-042	Var. H.V. Adjust
R812		1.8 meg	1/2 w	302-185	
R813		4.7 meg	1/2 w	302-475	
R814		4.7 meg	1/2 w	302-475	
R815		4.7 meg	1/2 w	302-475	
R830		47 k	1/2 w	302-473	
R831		1 meg	2 w	311-041	Var. INTENSITY
R832		4.7 meg	2 w	306-475	
R833		4.7 meg	2 w	306-475	
R834	101-6629 6630-up	100 k 33 k	1/2 w 1/2 w	302-104 302-333	
R835		1 meg	1/2 w	302-105	
R850		2.2 meg	2 w	306-225	
R851		2.2 meg	2 w	306-225	
R852		2 meg	2 w	311-043	Var. FOCUS
R853		1 meg	2 w	306-105	
R855		10 k	1/2 w	302-103	
R856		27 k	1/2 w	302-273	
R857		1 meg	1/2 w	302-105	
R860		100 k	2 w	311-026	Var. ASTIGMATISM
R862		100 k	2 w	311-026	Var. Geom. Adjust

† R697, R698 s/n 101-496 have to be replaced at the same time.

Rectifiers †

Tektronix Part Number

SR641 101-6921X 5-250 Ma plates per leg *106-018

Switches

Wired Unwired

SW210 SW230	101-5753	VOLTS, MILLIVOLTS, OFF; SQ. WAVE CALIBRATOR	Use *262-132
SW210 SW230			*262-132 *260-177
SW301 SW305	5754-up	VOLTS, MILLIVOLTS, OFF; SQ. WAVE CALIBRATOR	*262-083 *260-117
		TRIGGER SLOPE/MODE	
SW405 SW420 SW550	X5666-up	Furnished with R314 & R405 TIME/CM; 5X MAG	311-096
SW490 SW505			*262-084 *260-113
		MULTIPLIER	*262-085 *260-114
		HORIZ. DISPLAY	*262-086 *260-116
SW605	101-5665 5666-up	POWER ON POWER ON	Use 260-134 260-134
TK601		Thermal Cutout 137° F	260-120

Transformers

T605	Plate & Heater Supply T532PA 117 V operation	*120-056
T801	Plate & Heater Supply 234 v Operation CRT Supply	*120-105 *120-057

Electron Tubes

V115	12AU6	154-040	
V116	12AU6	154-040	
V135	6BQ7A	154-028	
V151	6CL6	154-031	
V152	6CL6	154-031	
V165	101-418 419-up	12AU7 6BQ7A 6AU6 6BQ7A 6AU6	154-041 154-028 154-022 154-028 154-022
V175		6AU6	154-022
V205		6BQ7A	154-028
V215		6AU6	154-022
V308	6U8	154-033	
V320	6U8	154-033	
V410	6BQ7A	154-028	
V430	6BQ7A	154-028	
V435	6BQ7A	154-028	
V440	6AU6	154-022	
V450	6AN8	154-078	
V460	6AL5	154-016	
V490	6AU6	154-022	
V505	12AU7	154-041	

† SN 6922-up See Diodes.

Electron Tubes (continued)

Part Number	Electron Tube	Tektronix Part Number
V510	6BQ7A	154-028
V530	6AU6	154-022
V535	6AU6	154-022
V560	6BQ7A	154-028
V575	6BQ7A	154-028
V605	5V4G	154-008
V606	5V4G	154-008
V615	6AU6	154-022
V619	12B4	154-044
V620	12B4	154-044
V630	5651	154-052
V635	12AX7	154-043
V650	6AU6	154-022
V658	6080 (6AS7 may be substituted, Tek # 154-020)	154-056
V661	5V4G	154-008
V662	5V4G	154-008
V668	6AU6	154-022
V680	12AX7	154-043
V685	5V4G	154-008
V695	6AU6	154-022
V696	12B4	154-044
V697	12B4	154-044
V803	6AQ5	154-017
V810	12AU7	154-041
V820	5642	154-051
V821	5642	154-051
V824	5642	154-051
V859	T52 CRT P2 standard phosphor	*154-097

Type 532 Mechanical Parts List

Part Description	Tektronix Part Number
ADAPTOR, 3 WIRE TO 2 WIRE	SN 6150-up 103-013
ANGLE FRAME TOP LEFT	SN 5001-up 122-019
ANGLE FRAME BOTTOM RIGHT	SN 101-6709 122-050
ANGLE FRAME BOTTOM RIGHT	SN 6710-up 122-071
ANGLE FRAME BOTTOM LEFT	SN 101-6709 122-051
ANGLE FRAME BOTTOM LEFT	SN 6710-up 122-070
BAR EXT. CHANNEL TOP SUPPORT W/HANDLES BLK. LEATHER	SN 101-6519 381-067
BAR $\frac{3}{16} \times \frac{1}{2} \times 1\frac{3}{4}$ W/2 8-32 TAPPED HOLES	381-073
BAR $\frac{1}{4} \times \frac{1}{4} \times 11\frac{17}{32}$ TAPPED 6-32	381-107
BAR EXT. CHANNEL TOP W/HANDLES BLUE LEATHER,	SN 6520-6709 381-121
BAR EXT. CHANNEL TOP W/HANDLES Blue Leather, Blue Vinyl	SN 6710-up 381-149
BASE, CRT ROTATOR $2\frac{3}{4} \times 3\frac{3}{16} \times \frac{3}{16}$	SN 6520-up 432-022
BOLT, SPADE STEEL 6-32 x $\frac{3}{8}$	214-012
BRACKET NYLON MLD. .600 x 1.313	406-101
BRACKET .080 x 2 x $6\frac{1}{2} \times 11\frac{17}{32}$	SN 101-5000 406-112
BRACKET $\frac{1}{4} \times \frac{1}{2} \times 7\frac{7}{8} \times 3\frac{3}{8}$	SN 101-5000 406-119
BRACKET FAN RING	SN 101-5000 406-151
BRACKET .080 x 1 x 2	SN 101-5000 406-160
BRACKET ALUM.	406-205
BRACKET .080 x $4\frac{3}{8} \times 3\frac{1}{2} \times 1\frac{5}{8}$	SN 5001-up 406-238
BRACKET .013 x $\frac{3}{4} \times 2\frac{1}{4} \times \frac{5}{8}$ (SP. PHOS. BRONZE)	406-239
BRACKET .080 x 1 x $1\frac{3}{16}$	SN 5001-up 406-240
BRACKET .160 x $\frac{3}{4} \times 1\frac{3}{8}$ (NYLON MLD.)	406-244
BRACKET $\frac{3}{4} \times \frac{1}{2} \times 1\frac{5}{16}$ (PHOS. BRONZE GROUND CLIP)	406-245
BRACKET .080 x $2\frac{1}{8} \times 1\frac{7}{8} \times \frac{3}{32}$	SN 101-5340 406-451
BRACKET .080 x $4\frac{3}{8} \times 3\frac{1}{2} \times 1\frac{5}{8}$	SN 5341-up 406-251
BUSHING NYLON	SN 101-6329 358-046
BUSHING NYLON	SN 6330-up 358-036
CABINET	437-018
CABLE HARNESS F & I	179-061
CABLE HARNESS POWER	179-091
CABLE HARNESS RECT.	179-092
CABLE HARNESS P. I.	179-094
CABLE HARNESS SWEEP	SN 419-up 179-124
CABLE HARNESS VA	SN 419-up 179-125

Mechanical Parts List (continued)

	Tektronix Part Number
CAP, FUSE	200-015
CHASSIS F & I SN 101-5000	441-065
CHASSIS F & I SN 5001-up	441-142
CHASSIS POWER	441-102
CHASSIS VA SN 419-up	441-121
CHASSIS SWEEP SN 419-up	441-122
CLAMP CABLE 1/8 PLASTIC	343-001
CLAMP CABLE 3/16 PLASTIC	343-002
CLAMP CABLE 5/16 PLASTIC	343-004
CLAMP CABLE 3/8 PLASTIC	343-013
CLAMP STN. STEEL 1/2 SN 101-5744	343-015
CLAMP CRT SOCKET SN 101-5000	343-027
CLAMP ACCESS PANEL 25/8 SN 5001-5541	343-033
CLAMP CRT 27/32 SN 5001-6519	343-034
CLAMP CABLE 5/16 PLASTIC (HALF)	343-042
CONNECTOR BINDING POST ADAPTOR	013-004
CONNECTOR 2 WIRE/2 CONNS. CHAS. MNT. SN 101-6149	131-010
CONNECTOR 16 CONN.	131-018
CONNECTOR CLIP ANODE SN 101-5918	131-026
CONNECTOR CHAS. MNT. (83 IRTY)	131-038
CONNECTOR CHAS. MNT. COAX SN 5001-up	131-064
CONNECTOR CABLE 31" ANODE	131-086
CONNECTOR 3 WIRE CHAS. MNT. SN 6150-up	131-102
CORD, PATCH 18" BANANA PLUG BOTH ENDS	012-031
COUPLING, POT WIRE STEEL .041	376-014
COVER ANODE RUBBER SN 101-5918	200-023
COVER GRATICULE	200-025
COVER CRT ANODE ASSEMBLY	200-112
EYELET, TAPERED BARREL	210-601
FAN, 7"	369-007
FILTER AIR 10 x 10 x 1 SN 101-5000	378-005
FILTER AIR 10 x 10 x 1 MOD. SN 5001-up	378-011
FILTER LIGHT PLEXI 5"	378-514
FRAME LEFT SN 101-5000	426-023
FRAME LIGHT SN 101-5000	426-024
FRAME FAN MOTOR SN 5001-up	426-047

Mechanical Parts List (continued)

	Tektronix Part Number
GRATICULE, 5"	331-026
GROMMET, RUBBER 1/4	348-002
GROMMET RUBBER 5/16	348-003
GROMMET RUBBER 3/8	348-004
GROMMET RUBBER 1/2	348-005
GROMMET RUBBER 5/8	348-012
HOLDER NYLON MOLDED (DOUBLE)	352-006
HOLDER FUSE	352-010
HOUSING AIR FILTER SN 101-5000	380-006
HOUSING AIR FILTER SN 5001-6709	380-008
HOUSING AIR FILTER SN 6710-up	380-018
JEWEL, LIGHT PILOT (RED)	378-518
KNOB SM. RED 3/16 INSERT HOLE	366-032
KNOB SM. BLK. 1/4 HOLE PART WAY SN 101-5400	366-044
KNOB SM. BLK. 1/4 INSERT HOLE SN 5401-up	366-033
KNOB SM. RED 1/8 HOLE PART WAY	366-038
KNOB SM. RED 3/16 HOLE PART WAY	366-039
KNOB LRG. BLK. 1/4 HOLE THRU	366-040
KNOB LRG. BLK. 1/4 HOLE PART WAY	366-042
KNOB LRG. BLK. 7/16 HOLE PART WAY	366-046
LOCKWASHER INT. #4	210-004
LOCKWASHER INT. #6	210-006
LOCKWASHER EXT. #8	210-007
LOCKWASHER INT. #8	210-008
LOCKWASHER INT. #10	210-010
LOCKWASHER POT INT. 3/8 x 1/2	210-012
LOCKWASHER INT. 3/8 x 1 1/16	210-013
LUG SOLDER SE6 W/2 WIRE HOLES	210-202
LUG SOLDER DE6	210-204
LUG SOLDER SE10 LONG	210-206
LUG SOLDER POT PLAIN 3/8	210-207
LUG SOLDER #10 NON-LOCKING 7/8 LONG	210-224
LUG SOLDER SE8 LONG	210-228
NUT CAP HEX 8-32 x 5/16	210-402
NUT HEX 4-40 x 3/16	210-406
NUT HEX 6-32 x 1/4	210-407

Mechanical Parts List (continued)

	Tektronix Part Number
NUT HEX 8-32 x 5/16	210-409
NUT HEX 10-32 x 5/16	210-410
NUT HEX 3/8-32 x 1/2	210-413
NUT HEX 15/32-32 x 9/16	210-414
NUT KNURLED, GRAT. 3/8-24 x 9/16 x 3/16	210-424
NUT HEX 3/8-32 x 1/2 x 5/8	210-444
NUT HEX 10-32 x 3/8 x 1/8	210-445
NUT KEPS 6-32 x 5/16	210-457
NUT KEPS 8-32 x 11/32	210-458
NUT HEX 8-32 x 1/2 x 23/64, 25 W RES. MTNG.	210-462
NUT SWITCH 15/32-32 x 5/64, 12 SIDED	210-473
NUT HEX 6-32 x 5/16 x .194 5-10 W RES. MTNG.	210-478
NUT 2 1/32 x 2 1/2 TAPPED 6-32 BOTH ENDS	210-503
PANEL FRONT SN 101-5000	333-205
PANEL FRONT (NEW CAB. STYLE "AC AUTO.") SN 5001-5419	333-270
PANEL FRONT (NEW CAB. STLYE "AUTO.") SN 5420-5665	333-273
PANEL FRONT (PRE-SET STABILITY) SN 5666-up	333-354
PLATE P. I. BACK	386-355
PLATE P. I. HOUSING LEFT	386-356
PLATE P. I. HOUSING RIGHT	386-357
PLATE CONNECTING .040 x 9/16 x 1 17/32	386-374
PLATE SUB-PANEL SN 101-5000	386-386
PLATE SUB-PANEL REAR SN 5001-up	386-557
PLATE RECT. .080 x 1 1/4 x 4 7/8 x 8 3/8	386-389
PLATE SWITCH SUPPORT .063 x 1 3/4 x 2 3/4 SN 101-5000	386-408
PLATE SWITCH SUPPORT .063 x 1 25/32 x 3 1/4	386-525
PLATE RECT. MTNG. SN 5001-up	386-547
PLATE RECT. MTNG. SN 5341-up	386-575
PLATE SUB-PANEL FRONT SN 5001-up	386-556
PLATE REAR OVERLAY SN 5001-6014	386-558
PLATE REAR OVERLAY SN 6015-6709	386-613
PLATE REAR OVERLAY SN 6710-up	387-079
PLATE PLEXI ACCESS PANEL SN 5001-5541	386-560
PLATE CAB. BOTTOM SN 5001-6014	386-563
PLATE CAB. BOTTOM SN 6015-6709	386-597
PLATE CAB. SIDE LEFT SN 5001-6014	386-564

Mechanical Parts List (continued)

	Tektronix Part Number
PLATE CAB. SIDE LEFT SN 6015-6709	386-736
PLATE CAB. SIDE LEFT SN 6710-up	387-077
PLATE CAB. SIDE RIGHT SN 5001-6014	386-565
PLATE CAB. SIDE RIGHT SN 6015-6200	386-737
PLATE CAB. SIDE RIGHT SN 6201-6709	386-770
PLATE CAB. SIDE RIGHT SN 6710-up	387-076
PLATE CAB. BOTTOM SN 6710-up	387-061
PLATE P. I. HOUSING SIDE SN 5133-up	386-566
PLATE SUB-PANEL REAR	386-766
PLATE FRAME BOTTOM SN 101-5000	387-527
PLATE FRAME TOP	387-528
PLUG, CRT CONTACT SN 5919-up	134-031
POST BINDING (355-503 & 200-072)	129-020
POST BINDING SN 101-6329	129-030
POST BINDING, FLUTED CAP SN 6330-up	129-036
RING FAN SN 101-5000	354-034
RING FAN SN 5001-up	354-053
RING LOCKING SWITCH	354-055
RING ROTATING SN 101-6519	354-066
RING FASTENER SN 6270-up	354-068
RING SECURING SN 6520-up	354-078
RING CLAMPING SN 6520-up	354-079
RING CLAMPING (354-079 & 210-502)	354-103
ROD EXT. 1/8 x 6 7/8	384-101
ROD HVO 1/4 x 3 1/8 TAPPED 6-32 BOTH ENDS	384-135
ROD SPACING 3/8 x 3 TAPPED 8-32 BOTH ENDS	384-527
ROD NYLON 5/16 x 1 1/8 TAPPED 6-32 ONE END SN 101-5000	385-075
ROD CRT SUPP. 1/4 x 7/16 SN 101-5000	385-080
ROD CRT SUPP. 1/4 x 1/2 TAPPED 6-32 THRU SN 5001-up	385-088
ROD FAN MNT. SUP. 1/2 x 3/8 WITH #18 HOLE THRU SN 101-5000	385-081
ROD 5/16 x 1 1/8 TAPPED 6-32 ONE END W/2 HOLES AT RIGHT ANGLES SN 5001-up	385-087
ROD ALUM. 5/16 x 1 9/16 TAPPED 6-32 BOTH ENDS	385-090
ROD DELRIN 5/16 x 5/8 MTNG. HOLE 3/8 DEEP ONE END W/1 #44 CROSS HOLE	385-134
ROD 5/16 x 1 5/16 MTNG. HOLE 3/8 DEEP ONE END W/2 #44 CROSS HOLES	385-135
ROD 5/16 x 1 1/4 MTNG. HOLE 3/8 DEEP ONE END W/3 #44 CROSS HOLES	385-136
SCREW 4-40 x 1/4 BHS	211-008

Mechanical Parts List (continued)

	Tektronix Part Number
SCREW 4-40 x 5/16 BHS	211-011
SCREW 4-40 x 5/8 RHS	211-016
SCREW 4-40 x 1/4 FHS	211-023
SCREW 4-40 x 3/8 FHS	211-025
SCREW 4-40 x 1 FHS	211-031
SCREW 4-40 x 5/16 PAN HS W/LOCKWASHER	211-033
SCREW 4-40 x 5/16 FHS, PHILLIPS	211-038
SCREW 6-32 x 3/16 BHS	211-503
SCREW 6-32 x 1/4 BHS	211-504
SCREW 6-32 x 5/16 BHS	211-507
SCREW 6-32 x 3/8 BHS	211-510
SCREW 6-32 x 1/2 BHS	211-511
SCREW 6-32 x 5/16 PAN HS W/LOCKWASHER	211-534
SCREW 6-32 x 3/8 TRUSS HS, PHILLIPS	211-537
SCREW 6-32 x 5/16 FHS, 100°, CSK, PHILLIPS	211-538
SCREW 6-32 x 1/4 FHS, 100°, CSK, PHILLIPS	211-541
SCREW 6-32 x 5/16 RHS	211-543
SCREW 6-32 x 3/4 TRUSS HS, PHILLIPS	211-544
SCREW 6-32 x 1 1/2 RHS, PHILLIPS	211-553
SCREW 6-32 x 3/8 FHS, 100°, CSK, PHILLIPS	211-559
SCREW 6-32 x 1 RHS	211-560
SCREW 6-32 x 3/8 FH CAP	211-561
SCREW 8-32 x 5/16 BHS	212-004
SCREW 8-32 x 1/2 BHS	212-008
SCREW 8-32 x 2 1/4 RHS	212-014
SCREW 8-32 x 3/8 BHS	212-023
SCREW 8-32 x 1 1/4 RHS	212-031
SCREW 8-32 x 1 3/4 FIL HS	212-037
SCREW 8-32 x 3/8 TRUSS HS, PHILLIPS	212-039
SCREW 8-32 x 3/8 FHS, 100°, PHILLIPS	212-040
SCREW 10-32 x 3 RHS	212-511
SCREW THREAD CUTTING 4-40 x 1/4 PAN HS, PHILLIPS	213-035
SCREW THREAD CUTTING 6-32 x 3/8 TRUSS HS, PHILLIPS	213-041
SCREW THREAD CUTTING 6-32 x 5/16 PHS, PHILLIPS	213-054
SHIELD P. I. HOUSING TOP .040 x 5 1/16 x 8 3/4 x 2 1/8	337-066
SHIELD P. I. HOUSING VERT. .025 x 6 1/32 x 7 7/8 SN 101-5132	337-067
SHIELD P. I. HOUSING VERT. .025 x 6 1/32 x 7 7/8 SN 5133-up	337-091

Mechanical Parts List (continued)

Tektronix
Part Number

SHIELD CRT		337-088
SHIELD CAL. SWITCH	063 x 2 ⁹ / ₁₆ x 1 ¹ / ₁₆ x 1 ³ / ₁₆	337-093
SHIELD F & I (&) H. V.		337-114
SHIELD F & I	.040 x 6 ³ / ₄ x 3 ³ / ₈ x 1 ¹ / ₂ SN 5001-up	337-148
SHIELD H. V.	SN 5001-up	337-151
SHIELD GRATICULE LIGHT	5"	337-187
SHOCKMOUNT, RUBBER	1/2 x 1/2	348-008
SOCKET GRAT. LAMP		136-001
SOCKET STM7G		136-008
SOCKET STM8 GROUND		136-011
SOCKET STM9G		136-015
SOCKET STM14		136-019
SOCKET LIGHT ASSEMBLY		136-025
SOCKET TIP JACK BLK.	SN 5001-up	136-037
SPACER TUBE	1/2 x 5/8 x 1/4 SN 101-5000	166-057
SPACER TUBE TRANS. SUPP.	.364 x 1/2 x 2 ⁹ / ₃₂ SN 101-5000	166-061
SPACE TUBE TRANS. SUPP.	.245 x 3/8 x 2 ¹ / ₃₂ SN 5001-up	166-105
SPACER TUBE	.180 x 1/4 x 7/32 ONE END CSK SN 5001-up	166-107
SPACER TUBE	.245 x 3/8 x 1/4 SN 5001-up	166-110
SPACER NYLON MLD. FOR CERAMIC STRIPS	SN 6370-up	361-009
STRAP, MOUNTING		346-001
STRIP FELT	1/8 x 1 x 5 ³ / ₄ GREY	124-068
STRIP CERAMIC	3/4 x 3 NOTCHES, CLIP MOUNTED	124-087
STRIP CERAMIC	3/4 x 4 NOTCHES, CLIP MOUNTED	124-088
STRIP CERAMIC	3/4 x 7 NOTCHES, CLIP MOUNTED	124-089
STRIP CERAMIC	3/4 x 11 NOTCHES, CLIP MOUNTED	124-091
STRIP CERAMIC	7/16 x 5 NOTCHES, CLIP MOUNTED	124-093
STUD STEEL	10-32 x 27/16	355-044
STUD CRT ROTATOR	10-32 x 3/16 x 3 1/4 SN 6520-up	355-049
TAG, VOLTAGE RATING		334-649
WASHER STEEL	6L x 3/8 x .032	210-803
WASHER STEEL	8S x 3/8 x .032	210-804
WASHER BRASS CENTERING	20W RESISTOR	210-808
WASHER BRASS CENTERING	25W RESISTOR	210-809
WASHER FIBER	#6 SHOULDERED	210-811

Mechanical Parts List (continued)

	Tektronix Part Number
WASHER FIBER #10 SHOULDERED	210-812
WASHER RUBBER	210-816
WASHER STEEL .390 x $\frac{9}{16}$ x .020	210-840
WASHER STEEL .119 x $\frac{3}{8}$ x .025	210-851
WASHER RUBBER $\frac{1}{2}$ x $\frac{1}{16}$ x $\frac{3}{64}$ (FUSE HOLDER)	210-873
WASHER STEEL .470 x $2\frac{1}{32}$ x .030	210-902
WASHER WAVY .007 PHOS. BRONZE .492 x .320 x .035	210-914

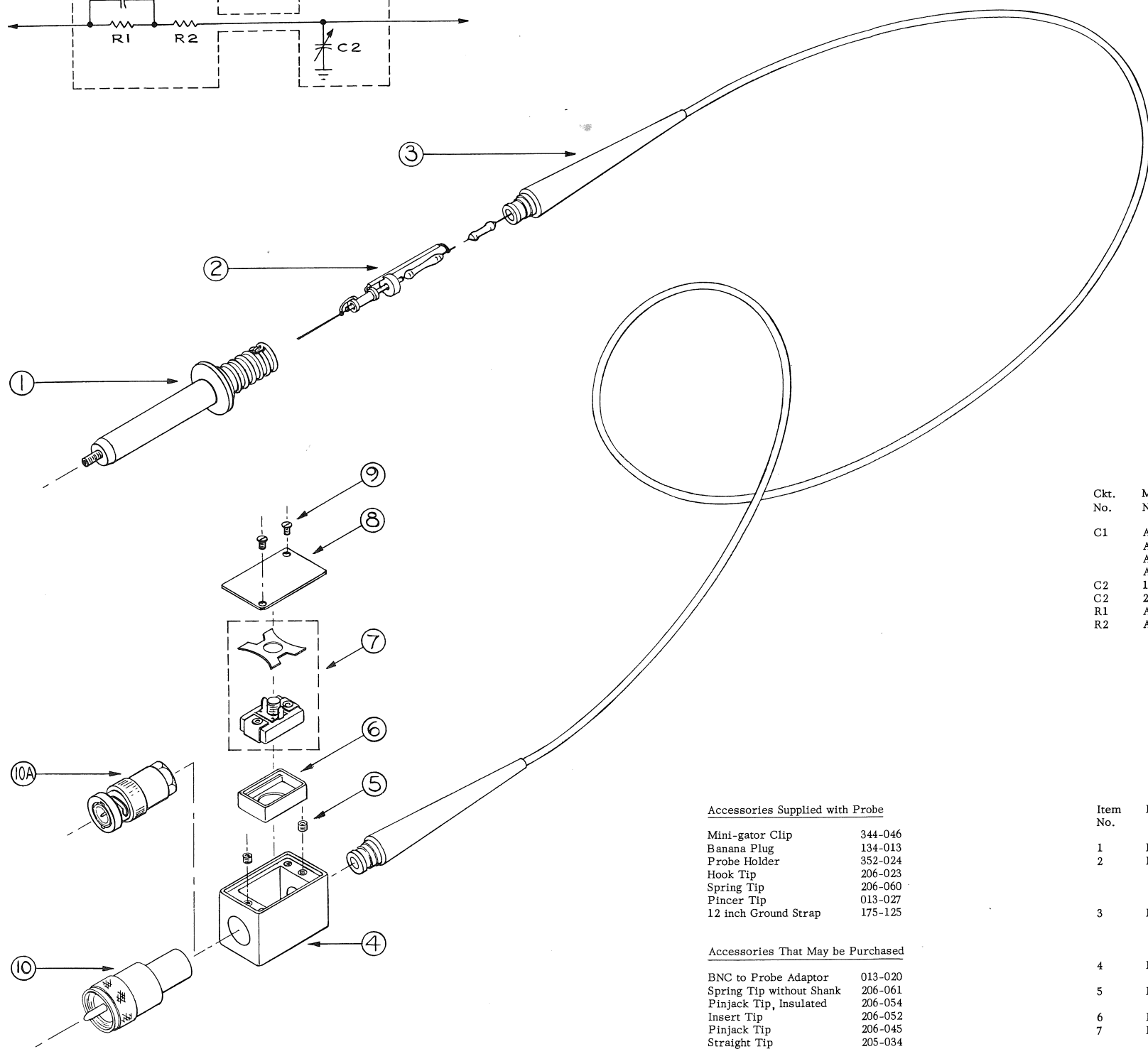
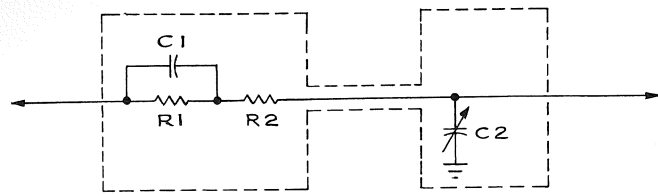

PROBES THIS SHEET COVERS

P6017

43 inches	Tektronix Part No.	010-038
6 ft.		010-056
9 ft.		010-057
12 ft.		010-058

P6022

43 inches	Tektronix Part No.	010-064
6 ft.		010-066
9 ft.		010-067
12 ft.		010-068

TABLE I ELECTRICAL PARTS

Ckt. No.	Model No.	Cable Length	Value	Description	Tektronix Part No.
C1	All	43 inches	11 μ f	Cer. Fixed 500v +or- 5%	281-576
	All	6 ft.	14 μ f		281-577
	All	9 ft.	18 μ f		281-578
	All	12 ft.	21 μ f		281-579
C2	1	All Lengths	8-50 μ f	Cer. Var. 500v	281-013
C2	2	All Lengths	5-80 μ f		Mica Var. 500v
R1	All	All Lengths	9 meg	1/2 w Fixed Prec. 2% Selected for proper cable termination. Furnished with cable.	309-232
R2	All	All Lengths			

NOTE

On the underside of the lid for the Compensation Box is the Model Number. If the probe shows no number it will be Model Number One.

TABLE II MECHANICAL PARTS

Item No.	Probe Type	Model No.	Cable Length	Part Title	Tektronix Part No.
1	P6017/P6022	All	All Lengths	Probe Body	204-054
2	P6017/P6022	All	43 inches	Attenuation Assembly	011-038
			6 ft.		011-037
			9 ft.		011-039
			12 ft.		011-040
3	P6017/P6022	All	43 inches	Cable Assembly	175-143
			6 ft.		175-185
			9 ft.		175-186
			12 ft.		175-187
			All Lengths		202-051
4	P6017/P6022	1 2	All Lengths	Compensator Box	202-068
					213-075
5	P6017/P6022	All	All Lengths	Allen Set Screws 4-40 x 3/32	200-098
6	P6017/P6022	2 only	All Lengths	Positioning Insulator	281-013
					1
7	P6017/P6022	1 2	All Lengths	Compensating Capacitor and Spring Clip Assembly	281-013
					2
8	P6017/P6022	All	All Lengths	Plate Cover	200-248
9	P6017/P6022	All	All Lengths	Thread Cutting Screw 4-40 x 1/4	213-035
10A	P6017	All	All Lengths	Connector, UHF	131-058
10	P6022	All	All Lengths	Connector, BNC	131-186

Accessories Supplied with Probe

Mini-gator Clip	344-046
Banana Plug	134-013
Probe Holder	352-024
Hook Tip	206-023
Spring Tip	206-060
Pincer Tip	013-027
12 inch Ground Strap	175-125

Accessories That May be Purchased

BNC to Probe Adaptor	013-020
Spring Tip without Shank	206-061
Pinjack Tip, Insulated	206-054
Insert Tip	206-052
Pinjack Tip	206-045
Straight Tip	205-034
BNC Tip	206-015
5 inch Ground Strap	175-124
18 inch Ground Strap	175-184

V 308
TRIGGER AMPLIFIER

V 320
TRIGGER SHAPER

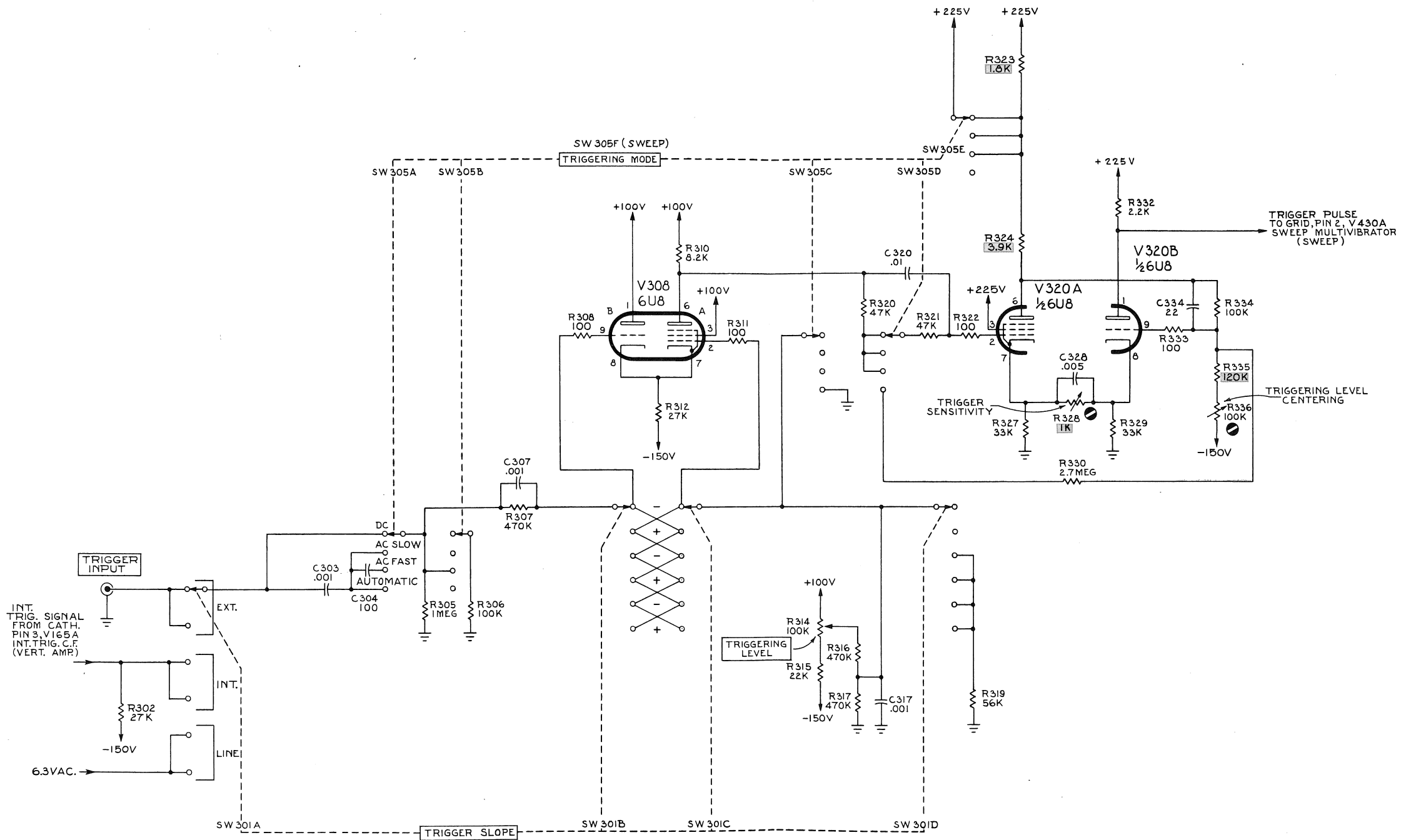

R.O.V.
4-28-59

SEE PARTS LIST FOR EARLIER
VALUES AND S/N CHANGES
OF PARTS MARKED

TYPE 532 OSCILLOSCOPE

AA

SWEEP TRIGGER

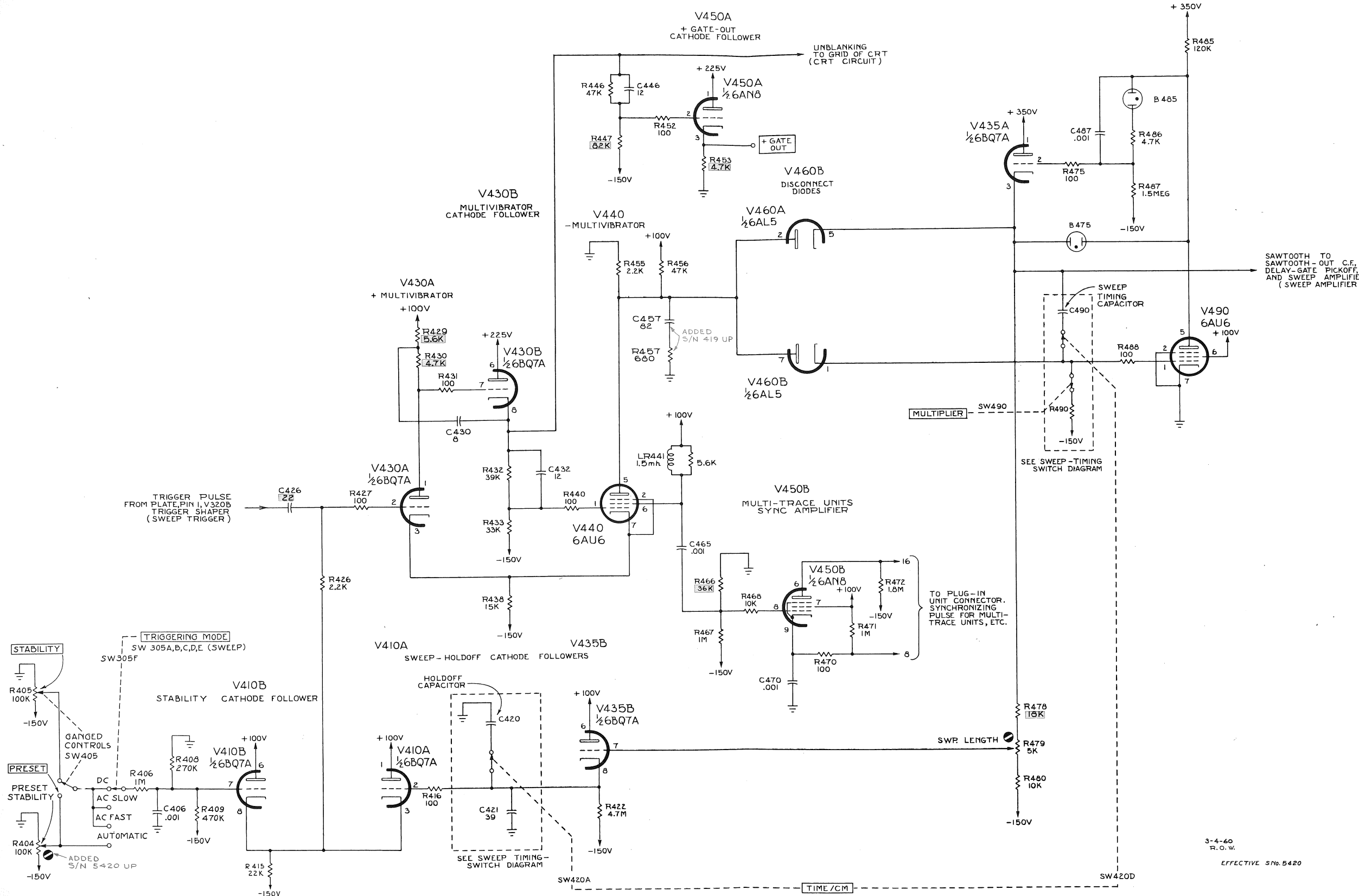

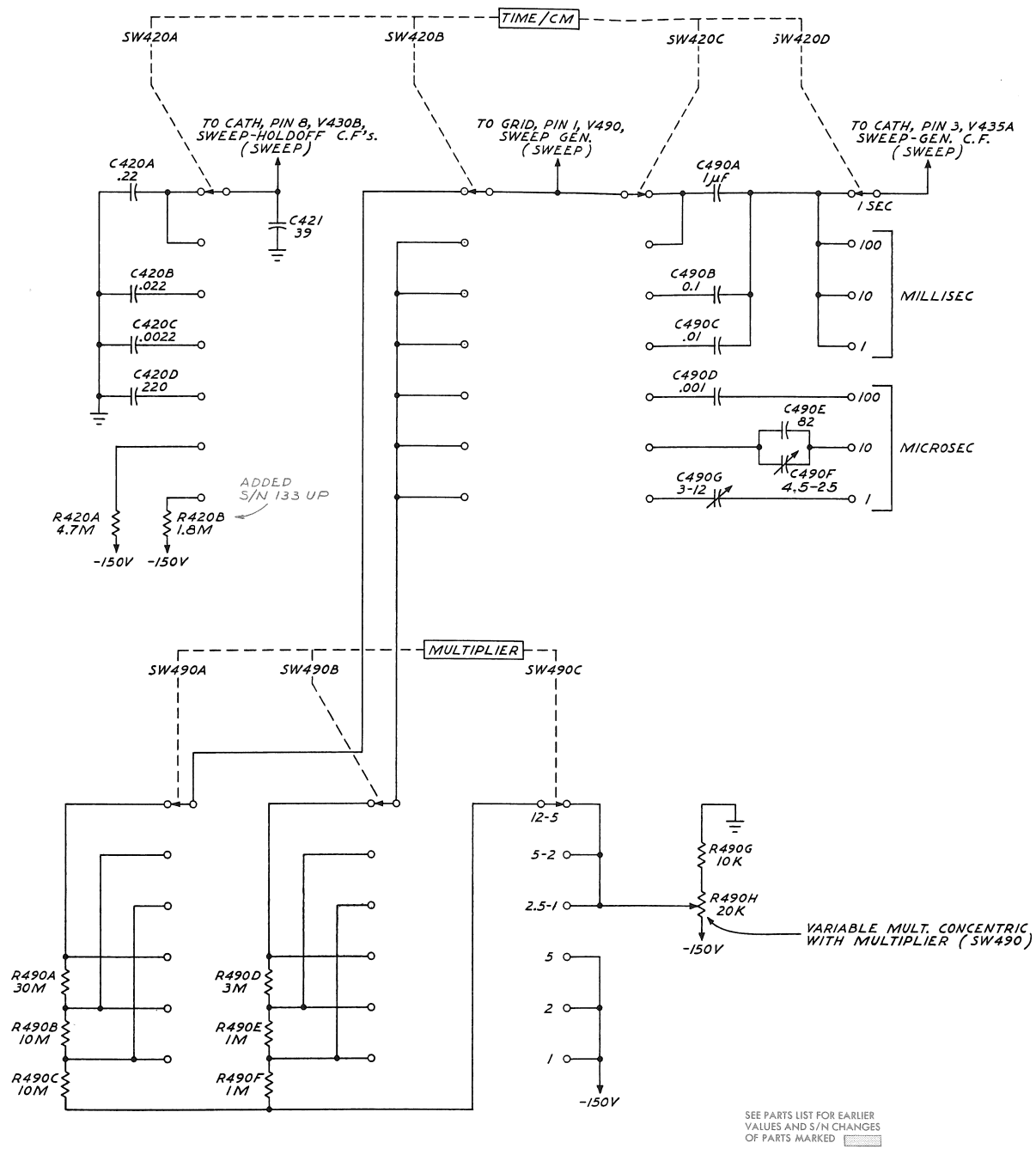

TYPE 532 OSCILLOSCOPE

SWEEP GEN. TIMING SWITCH

B-1-55
KF

+

AA

V530
V535
DELAYED-GATE
PICKOFF

V505A
DELAYED-GATE C.F.

V505B
SAWTOOTH-OUT C.F.

V510A
V510B
EXTERNAL-SWEEP
AMPLIFIER

SAWTOOTH, FROM CATHODE,
PIN 3, V435A, SWEEP-GEN. C.F.
(SWEEP)

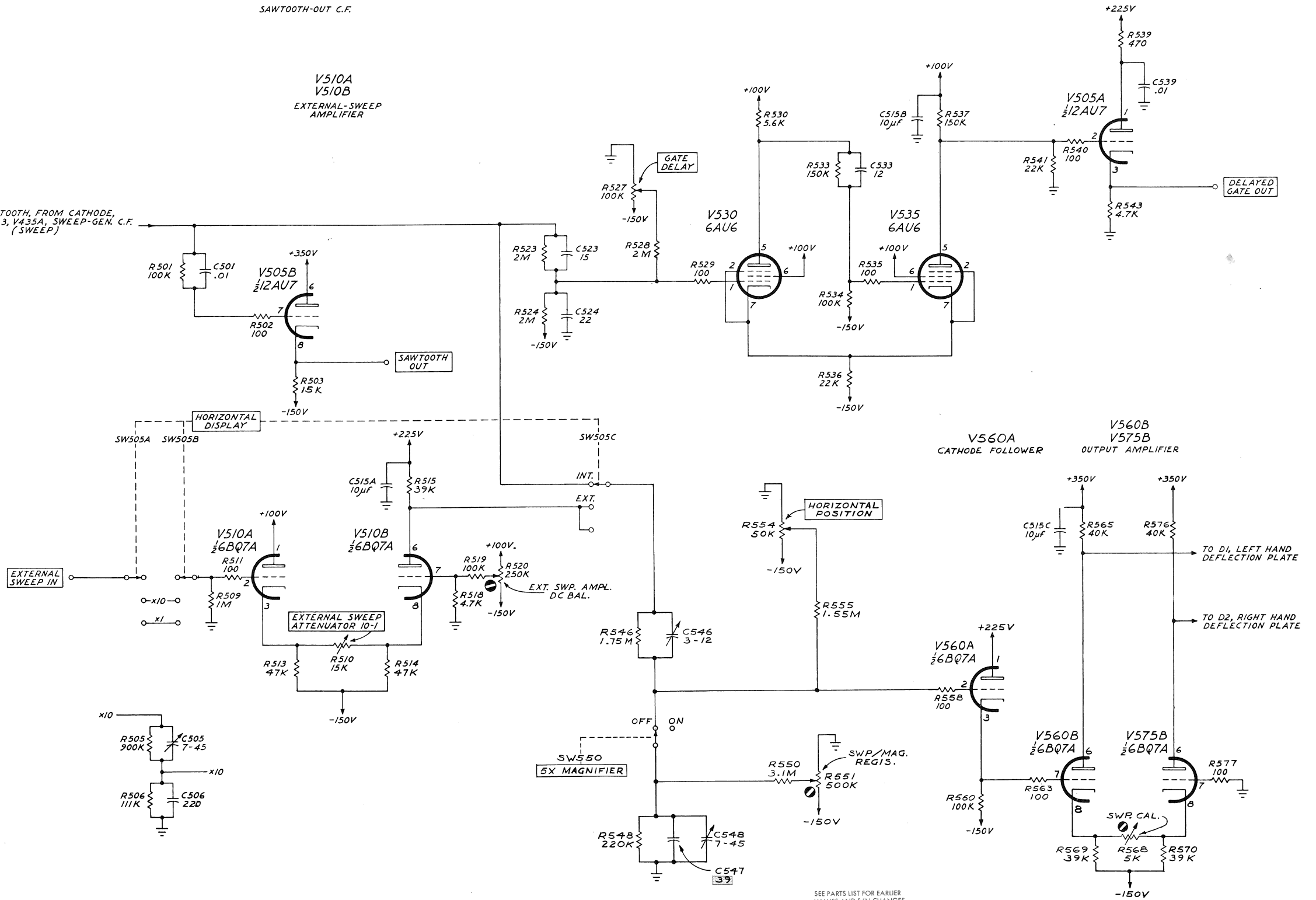

SEE PARTS LIST FOR EARLIER
VALUES AND S/N CHANGES
OF PARTS MARKED

8-1-55
K.F.

V530
V535
DELAYED-GATE
PICKOFF

V505A
DELAYED-GATE C.F.

V505B
SAWTOOTH-OUT C.F.

V510A
V510B
EXTERNAL-SWEEP
AMPLIFIER

SAWTOOTH, FROM CATHODE,
PIN 3, V435A, SWEEP-GEN. C.F.
(SWEEP)

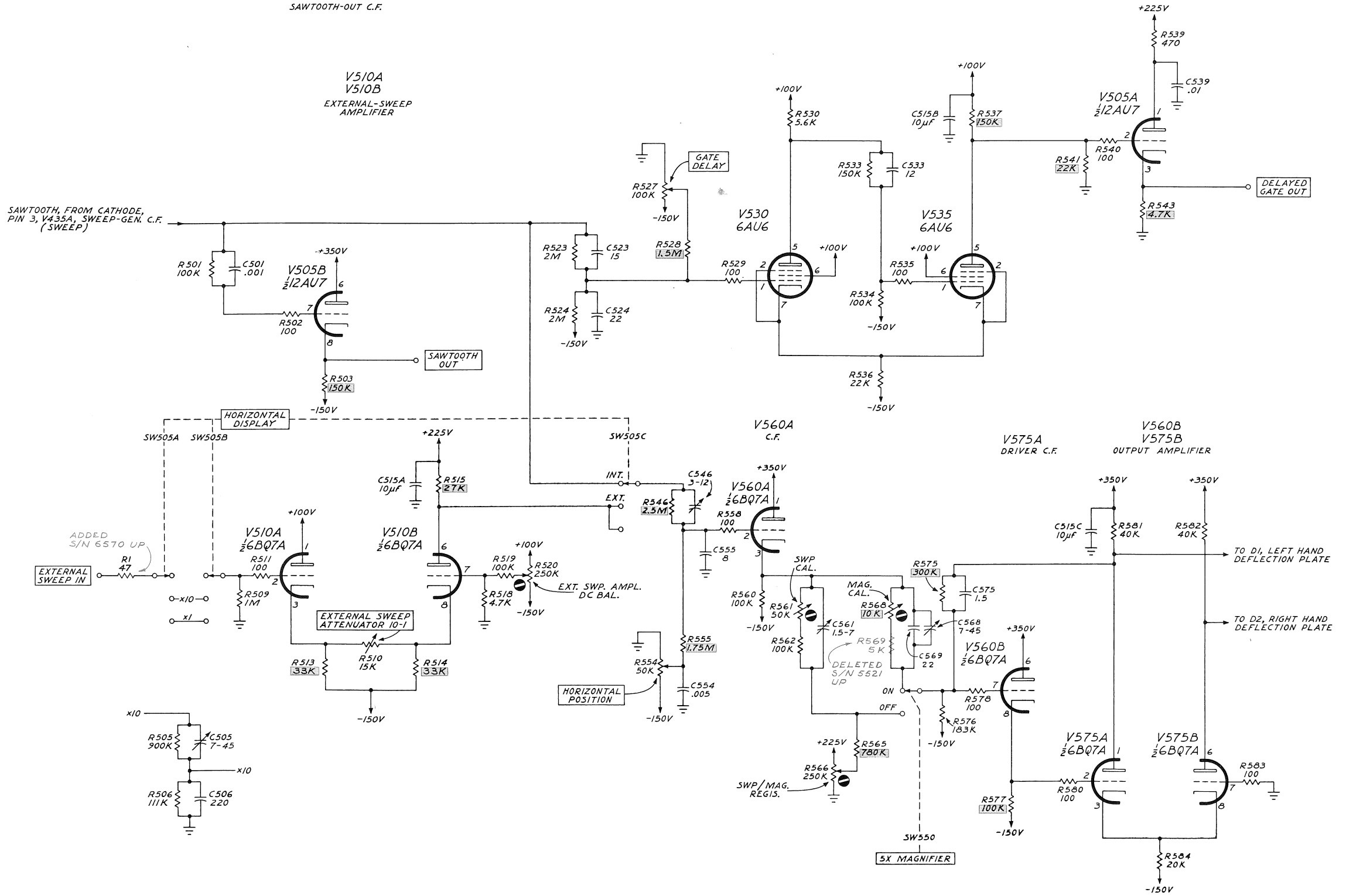

SEE PARTS LIST FOR EARLIER
VALUES AND S/N CHANGES
OF PARTS MARKED

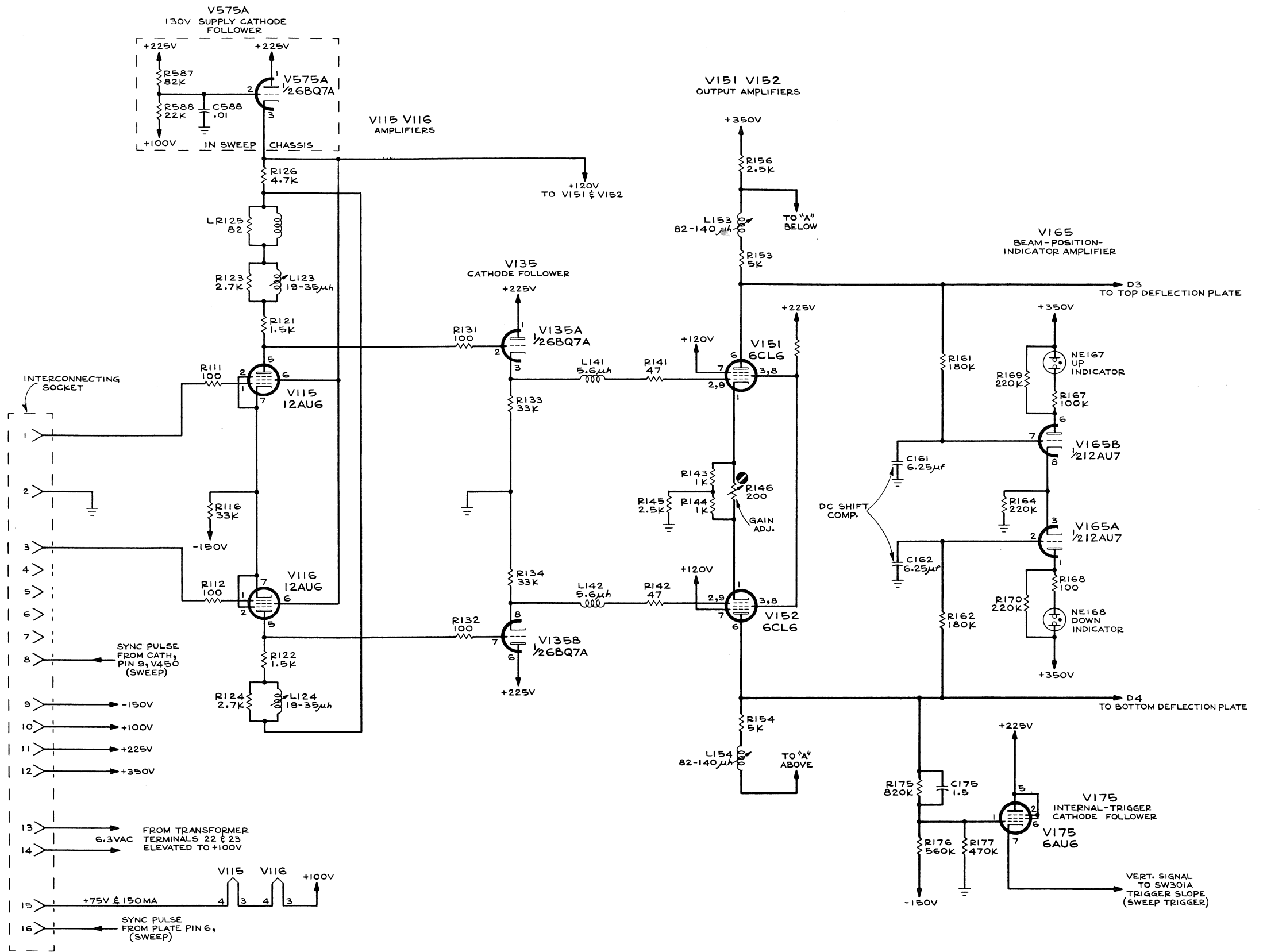

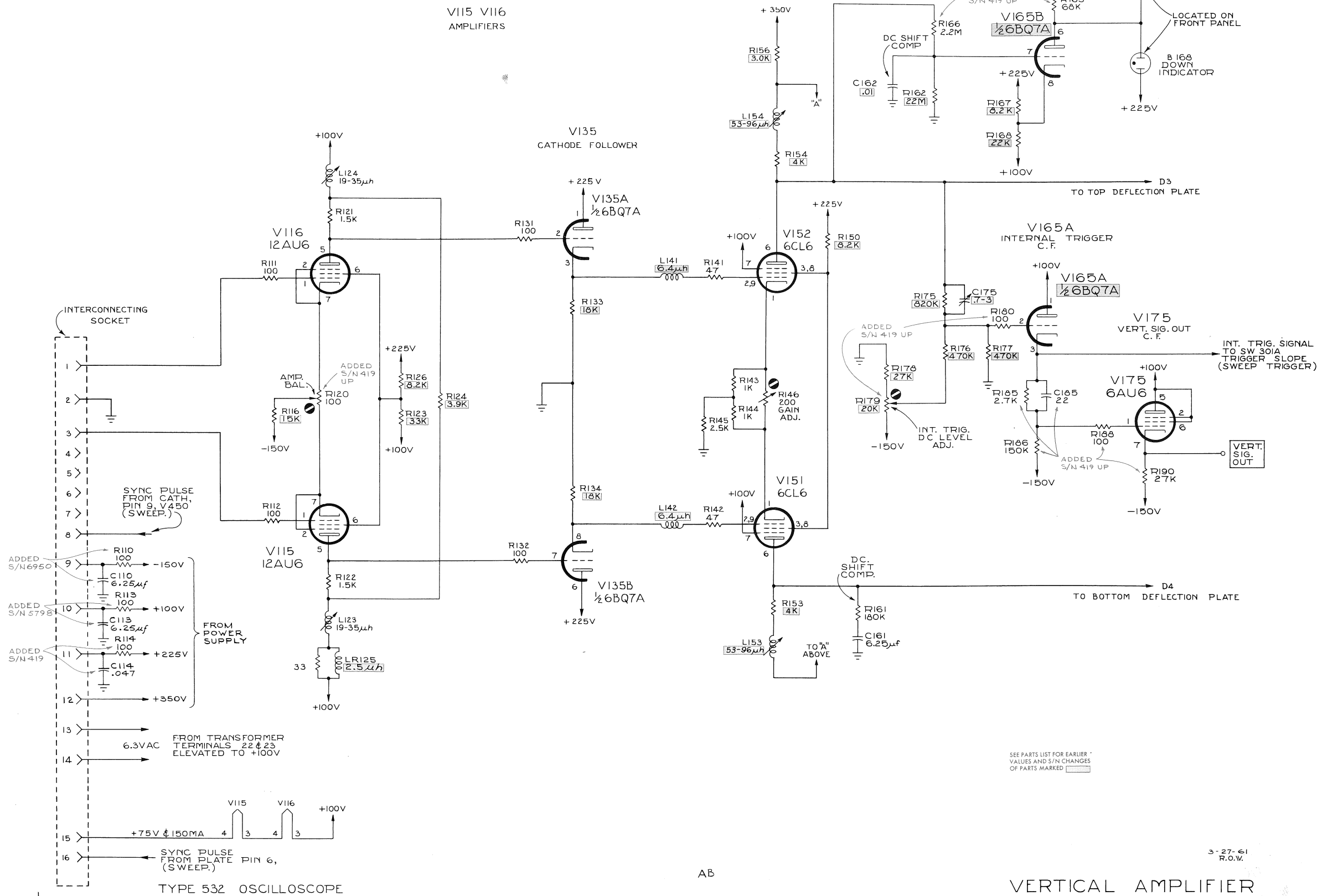

TYPE 532 OSCILLOSCOPE

AB

VERTICAL AMPLIFIER
S/N 419 UP

532 VERT. AMP. S/N 419 UP

V205A V215
CALIBRATOR MULTIVIBRATOR

V205B
CALIBRATOR
CATHODE FOLLOWER

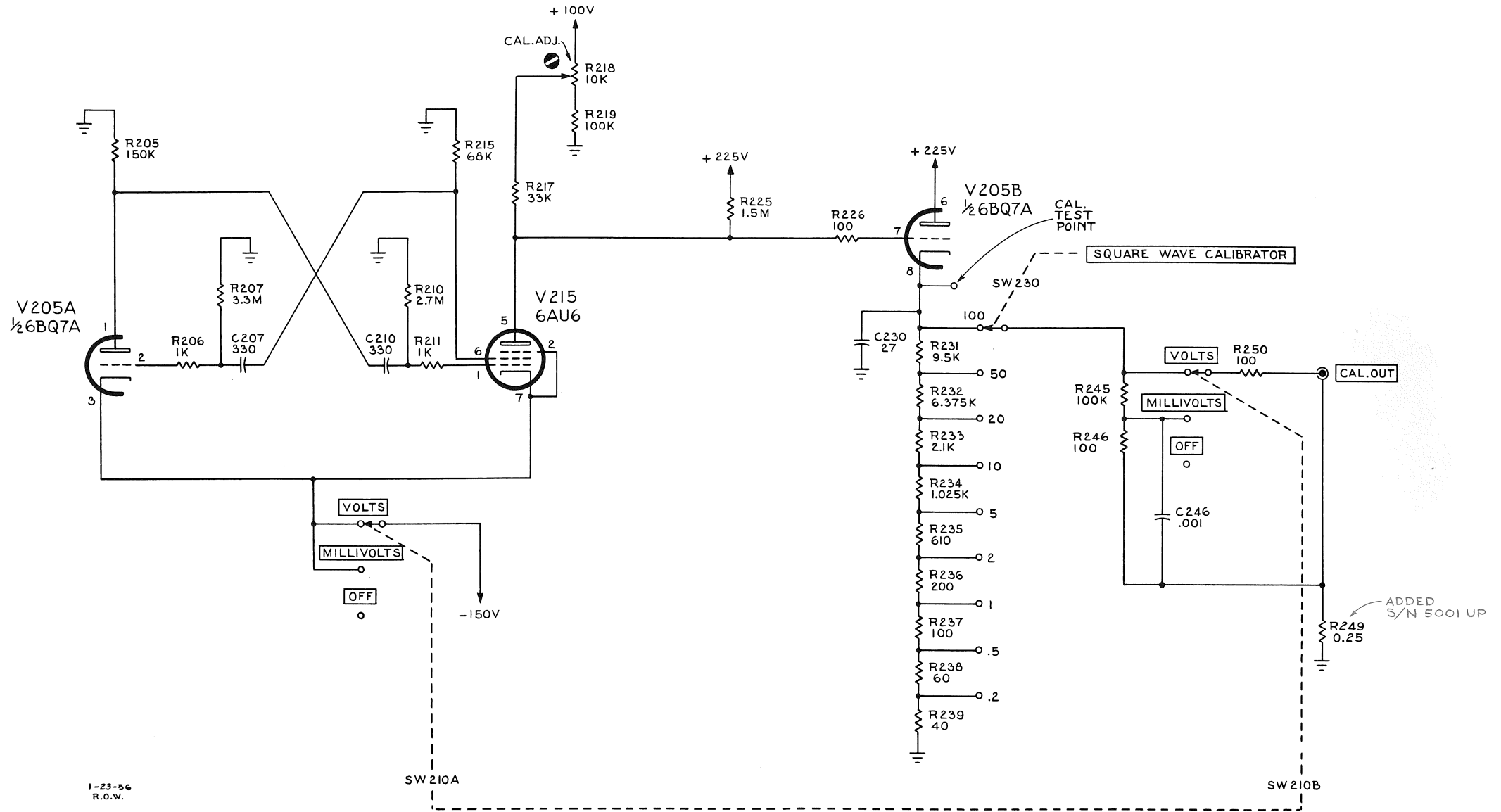

1-23-56
R.O.W.

SW 210A

SW 210B

SEE PARTS LIST FOR EARLIER
VALUES AND S/N CHANGES
OF PARTS MARKED

TYPE 532 OSCILLOSCOPE

AA

CALIBRATOR

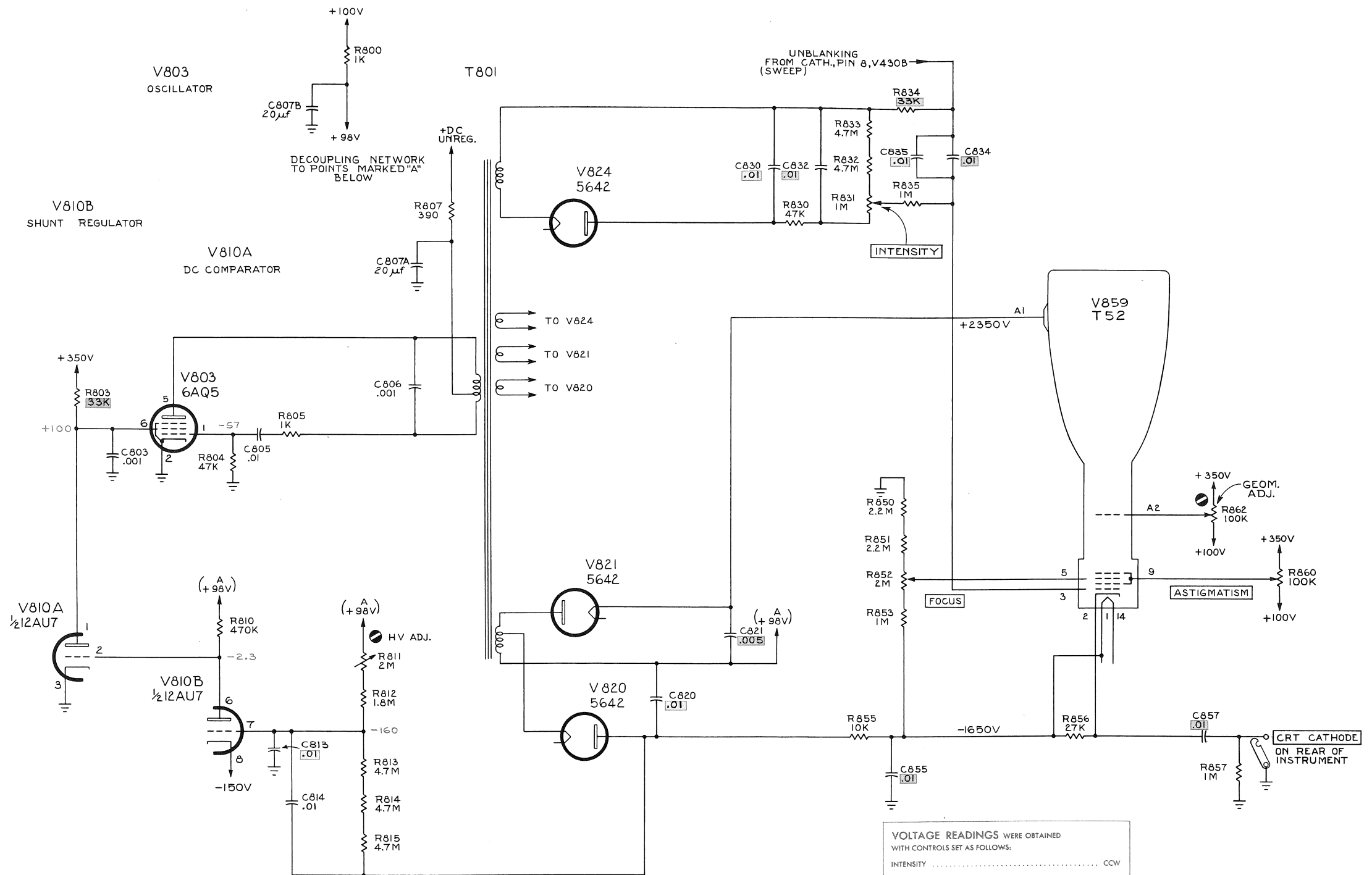

VOLTAGE READINGS WERE OBTAINED WITH CONTROLS SET AS FOLLOWS:
 INTENSITY CCW
 SEE ALSO IMPORTANT NOTE ON SWEEP TRIGGER DIAGRAM.

R.O.W. 3-9-61
 C.R.T.

SEE PARTS LIST FOR EARLIER VALUES AND S/N CHANGES OF PARTS MARKED

TYPE 532 OSCILLOSCOPE

CRT CIRCUIT

AC

+