

SERVICETEKNOTES

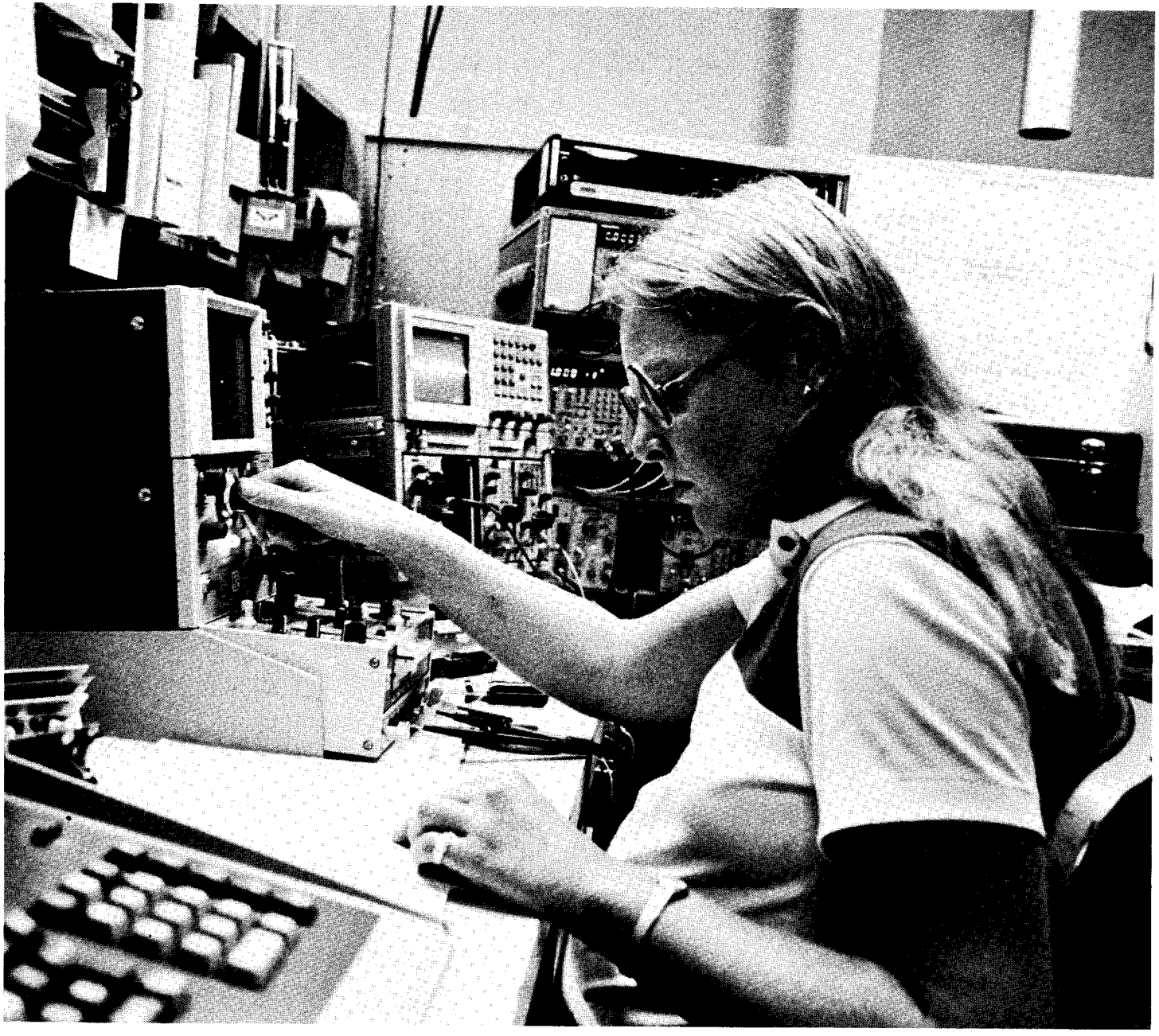

About our cover:
Kathy White, Field Electronics
Technician II, is Factory Services'
specialist on Curve Tracers. She
also specializes on the 7000 Series
instruments.

Kathy is shown here working on a
Curve Tracer.

TABLE OF CONTENTS

1980 GRAPHIC USER'S MANUAL - NEW	1
DC503A/DP501 INTERFACING INSTRUCTIONS.	2
DC510/5010 PHASE LOCK LOOP IMPROVEMENT	2
FG502 DISTORTION & AMPLITUDE FLATNESS IMPROVEMENTS	3
R7103 OSCILLATION.	3
S-3295: PROCEDURE FOR CHANGING LINE PRINTER COLUMN WIDTH	3
SG5010 ADJUSTMENT PROCEDURE CORRECTIONS.	4
SI5010, MI5010 COMMAND FORMAT ANOMALY.	4
TDC RESONATOR SPACER RING MOD.	5
TSG 6/16/26 FREQUENCY RESPONSE & HARMONIC DISTORTION PROBLEMS.	5
TSG 7/11/21 OPT. AB, MANUAL CHANGES.	6
7L13/7L14 30Hz VARIABLE RESOLUTION FILTER.	6
49X/P SEMI-RIGID COAX CABLES IMPROVED.	6
49X/P VARIABLE RESOLUTION MODULE HOUSING	7
110-S SERVICE MANUAL RE-WRITE.	7
147A/148/149A RACKMOUNT TO CABINET CONVERSION.	7
149A OPT. 1 HORIZONTAL TIMING BOARD REPLACEMENT.	7
411X/412X/4170/4926/4041 WINCHESTER CONTROLLER HELPFUL HINTS	8
463X PROCESSOR FRAME SECTION CONDUCTIVE COATING.	9
520A SERIES CENTER DOT SHIFT	10
528 MOD 254 F/G HORIZONTAL POSITION POT.	10
528A INTENSITY LIMIT ADJUSTMENT.	10
1410 SERIES MAIN CABLE MOD	11
1420 SERIES INTENSITY LIMIT ADJUSTMENT	11
1450-1 WIDEBAND AUDIO MOD.	11
1750 SERIES, DUAL DISPLAY UPGRADE.	12
1750 SERIES, HORIZONTAL JITTER	12
1750 SERIES INCONSISTENT LOCK-UP	13
4014, 4015, 4081, 619 YOKE ASSEMBLY.	13
4100F42/F43 OPTION 01 CORRECTIONS.	13
4109/CX LVPS MODIFICATION 53927.	14
4112X/4113X/4114X/4116X MOTHERBOARD KEYS	14
4115B/4120 SERIES OPTION 9/19 ERROR CODES NOT DOCUMENTED	15

4510 RS-232 HARDWARE FLAGGING. 15
4631/4632 HEATER CONTROL CABLE IMPROVED. 15
4632 COPY DISTORTION PROBLEM 15
4692: POWER SUPPLY DAMAGE HAZARD 16
4692 T.V. PATTERN GENERATOR CABLE MOD. 17
4695: JETS CLOGGED/ERRATIC DOTS CAUSED BY THICK INK AND LOW
COPIER USAGE 16
4907 FIRMWARE 1.4 OPERATING CHARACTERISTICS 16
4909 HEAD CRASH CHECK. 17
7612D POWER SUPPLY (-5.2V) ADJUSTMENT. 18
016-0596-0X RGB MIXER FUSE CHANGE. 18

1980 GRAPHICS USER'S MANUAL -- NEW

REF: 1980 Tek Answer BASIC
Graphics User's Manual

P/N 070-4457-00

The 1980 Graphics User's Manual has been updated and is available through the normal parts ordering system.

To obtain your copy, order P/N 070-4457-00.

This manual replaces the "Preliminary Graphics Manual", P/N 061-2374-00.
Issue 15-11

Please note:

Reference to "Issue" number following each article refers to the WIZARDS WORKSHOP issue in which this article originally appeared.

DC503A/DP501 INTERFACING INSTRUCTIONS

Reference:

Instruction Manuals

- DP501 --- 070-4332-00
- DC503A --- 070-2971-00

The following instructions will enable proper interfacing of these plug-ins so the DC503A can read the DP501 input signal directly.

*Note: - A mainframe with rear interface option is required.

If these rear interface connections are not made the counter will read 1/16th the DP501 input frequency (in other words you will need to multiply the DC503A displayed frequency by 16 to obtain the correct DP501 input frequency).

Interfacing Instructions

- 1) Move DC503A jumper A14J1720 from the NORMAL position to the TTL position.
- 2) Connect the following at rear interface:

DP501 - 21B(GRD) and 15A(GRD) to
DC503A - 15A(GRD)
DP501 - 15B(Ref Clk Input) to
DC503A - 15B(Ref. Clk Out)

DP501 - 21A (divide by 16 Clk out) to
DC503A - 21A(TTL Clk Input)

- 3) Front panel cabling and control settings:

- DP501 --- PRESCALE mode
- Connect signal to DP501 input
- DP501 output to DC503A CHA input
- DC503A function --- FREQ A display time --- as desired
- AVGS/timing --- as desired
- Adjust CHA level control as needed to obtain a stable display.

Any questions concerning this set-up please contact me.

Issue 15-11

DC510/5010 PHASE LOCK LOOP IMPROVEMENT

REF: SN B041460
M 57882

The phase lock loop does not always lock properly to the reference signal at elevated temperatures after a repair. This has been traced to the thermal characteristics of A12U1022, with Hitachi brand parts of date code 8305 and newer most likely to fail.

To compensate, A12R1113 was changed to 51 ohms, PN 315-0510-00, and a 100 ohm resistor PN 315-0101-00 was connected between pins 2 and 4 of A12U1022. These resistors increase the loading of A12U1022 to make its output more independent of temperature.

A parts kit, 050-2081-00, has been set up for replacement of A12U1022. The kit consists of A12U1022, the two resistors, and instructions. Since all products passed high temperature tests before leaving the factory, this 050 kit should only need to be installed when A12U1022 is replaced. This change has already been installed in all units of serial number B041460 and higher.

Issue 15-8

FG502 DISTORTION AND AMPLITUDE
FLATNESS IMPROVEMENTS

REF: SN B073990
M 58109

Two changes have been made to the FG502 to reduce distortion, and to improve amplitude flatness above 10 Mhz. These changes can be installed in any FG502 where improved performance is needed. All FG502's manufactured since serial number B073990 had these changes installed at the factory.

To reduce distortion, op amps U140 and U175 were replaced by LF356N parts, Tek P/N 156-1156-00. The new parts are a direct replacement. The frequency response of the LF356N is better matched to the requirements of the triangle generator, thereby reducing a tendency for oscillation and distortion.

The bandpass of the AC attenuator at the output of the triangle generator was altered to improve it's frequency response. C224 was changed to 65 pf, Tek P/N 283-0634-00. This change will also aid in adjusting the Square Wave compensation by reducing the effect of the compensation circuits on the sine wave amplitude flatness characteristics.

Issue 15-10

R7103 OSCILLATION

REF: R7103 Manual, P/N 070-5039-00

An oscillation has been observed on some R7103 mainframe oscilloscopes at the top and/or bottom of the screen with some input signals, such as timemarks. This oscillation is originating in the signal-out circuit.

To eliminate this oscillation, engineering change number 57863 has added A14C464, a 10pf capacitor (283-0175-00) across (in parallel with) A14R464.

Issue 15-8

S-3295: PROCEDURE FOR CHANGING LINE
PRINTER COLUMN WIDTH

REF: Tektest V Version II (RSX) Users Only

S-3295 users with Tektest V Version II now have a procedure for changing the line printer column width.

Procedure: Be sure nothing is currently in the print que. To switch from 80 to 132 characters per column, enter the following string of commands.

```
QUE /STOP:QMG
REM LPO
INS $LPP132COL.TSK
QUE /START:QMG
QUE LPO:/SPOOL/FLAG:1/FORM:0/SHARE
QUE LPO:ASSIGN:PRINT
```

To switch from 132 to 80 characters per column, perform the above steps and replace \$LPP132COL.TSK in the third command line with \$LPP.TSK. Both of these command files are required and must be resident on the system disk.

Also, to return to the default (80 characters) you may reboot the system.

The required command files may be obtained during the next software update.

Issue 15-14

SG5010 ADJUSTMENT PROCEDURE CORRECTIONS

REF: SG5010 Instruction Manual
(070-4331-00)

The Adjustment Procedure for this product is incomplete as described in the manual. The below listed corrections should be adhered to when calibrating this instrument.

The Adjustment Procedure is located on pages 6-1 through 6-7 in the instruction manual.

Procedure Changes:

Step 1

- no changes

Step 2

- Test cable should be connected from SG5010 + and - connectors to the RMS voltmeter. Figure 6-1 should be corrected to reflect this change.
- Step (b) should be changed to 2.00 vac.

Step 3

- Step (b) the + lead should be connected to TP6161 and the - lead to TP3183.

Step 4

- no changes

Step 5

- SG5010 Control Settings
 - . Press - RECALL SMPTE/DIN
- Step (a) should indicate that the cable is connected from the SG5010 + and com connectors to the RMS voltmeter input.

Step 6

- SG5010 Control Settings
 - . Function - SQUARE WAVE
- note: cable is connected to + and com

Step 7

- SG5010 Control Settings
 - . Function - CCIF
 - . Freq - Between 2.5KHZ and 163.8KHZ
 - . IM Freq - 500HZ
 - . VRMS - 2.00V
- note: cable connected to + and com

Step 8

- no changes

Step 9

- no changes

Issue 15-13

SI5010, MI5010 COMMAND FORMAT ANOMALY

It has been observed that the SI5010 and MI5010 will issue an error code if spaces are placed between a command and the carriage return. Other TM5000 products ignore these spaces and issue no error.

This does not create a problem with Tek controllers, as they do not insert these spaces unless the operator deliberately inserts the spaces. However, some other brand controllers routinely insert spaces between the command and carriage return, resulting in an error.

A workaround is to place a semicolon (;) after the command. An example would be 'SET?;'. The semicolon separates the spaces from the command, allowing the SI5010 and MI5010 to ignore the spaces.

This anomaly will not be changed, as there is no violation of the ANSI/IEEE Std 488-1978. The Tektronix GPIB codes and formats standards have been revised to provide future consistency in new products.

Issue 15-13

TDC RESONATOR SPACER RING MOD

REF: TDC Instruction Manual,
070-2597-01
Mod 58118

One of the five helical resonator spacer rings, P/N 354-0564-00, has been modified to provide additional mechanical clearance. In particular, index #94 on the exploded view drawing (Fig. 1 in your TDC manual) has been shortened by 0.1 inch. This is the ring that is used in conjunction with the A8 VCO board.

The new part (P/N 354-0564-02) will be used in new TDC's from the factory starting with serial number B011250, and can be used to repair older TDC's where there are problems associated with the TDC rubbing on the 1450 in the A8 area as it is inserted or removed from the frame.

Issue 15-10

- o L514 (P/N 108-0683-00) was added, "teepee" fashion, in series with C514
- o L515 (P/N 108-0683-00) was added, "teepee" fashion, in series with C515.

The schematic below illustrates the circuit changes.

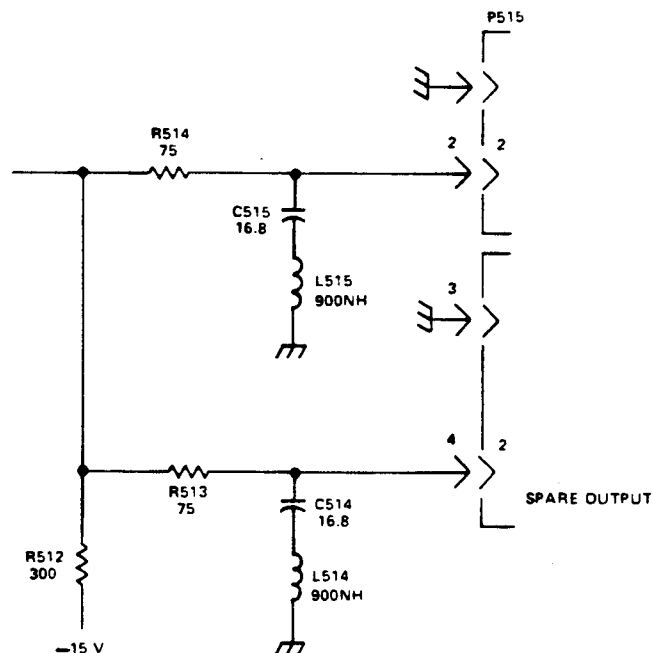

TSG 6/16/26 FREQUENCY RESPONSE & HARMONIC DISTORTION PROBLEMS

REF: TSG 6 Instruction Manual
P/N 070-2528-00

TSG 16 Instruction Manual
P/N 070-2649-00

TSG 26 Instruction Manual
P/N 070-4567-00

Mod 56813

In order to provide a more predictable flat frequency response, and to eliminate some high order harmonics, Mod 56813 has made the following changes:

- o Q508 was changed from 151-0410-00 to 151-0220-03

The parts required to implement this mod are available as a kit, P/N 050-2056-00, and should be installed upon failures of Q508 or Q352, or upon receipt of customer complaints concerning frequency response or the presence of excessive high order harmonics.

Mod 56813 will be installed in new instruments from the factory with the following starting serial numbers:

TSG 6	B011825
TSG 16	B011297
TSG 26	B010118

Issue 15-10

TSG 7/11/21 OPT. AB, MANUAL CHANGES

REF: TSG7 Opt. AB Manual Supplement
P/N 070-4908-00

TSG11 Opt. AB Manual Supplement
P/N 070-4909-00

TSG21 Opt. AB Manual Supplement
P/N 070-4910-00

Enclosed with this issue as pull-out
supplements are changes to the
calibration procedures for the TSG
7/11/21 Opt. AB.

Issue 15-10

7L13/7L14 30Hz VARIABLE
RESOLUTION FILTER

REF: M57015

The 7L13/7L14 30Hz Variable Resolution
Filters, A78FL3052 (7L14) and FL2730
(7L13) P/N 119-0449-01, have changed
characteristics due to manufacturing
process improvements by the vendor.
Filters with date codes 8514 and above
have a lower insertion loss, causing
7L14 gain pots A78R3038 and A78R3030,
and 7L13 gain pots R2730 and R2735 to
have insufficient range. To
compensate for the improved filter
characteristics, a mod has been
completed to lower the 30Hz V.R.
Amplifier circuit gain.

On A78, the 7L14 YIG Driver Board,
A78R3037, has been changed from 402
Ohms to 249 Ohms, P/N 321-0135-00.
The 7L14 YIG Driver circuit board
changes to P/N 670-6061-05 and the
7L14 Opt. 39 YIG Driver circuit board
changes to P/N 670-6061-04. For field
replacement of A78FL3052 (7L14) and
FL2730 (7L13), parts replacement kit
P/N 050-2041-00 has been set up for
use as follows:

7L13	All Serial Numbers
7L14	S/N B010100 - B011013
7L14 Opt. 39	S/N B010100 - B011007

This circuit mod is only required when
installing 30Hz filters with date
codes 8514 and above. All 30Hz
filters with date codes below 8514 may
be used to replace FL2730 or A78FL3052
in all 7L13 and 7L14 Spectrum
Analyzers.
Issue 15-9

49X/P SEMI-RIGID COAX CABLES IMPROVED

RE: M52330

A Mod has been completed which will
increase the reliability of semi-rigid
coax cables used in 49X/P products.
The brass ferrule has been replaced by
a glass filled plastic ferrule, which
reduces damage to the cables caused by
over-tightening of the coupling nut.

The new cables may be used as direct
replacements for existing 49X/P
semi-rigid coax cables. Part numbers
effected by this Mod are listed below:

175-2183-02	175-2762-02	175-3747-05
175-2199-02	175-2337-02	175-3748-05
175-2200-02	175-9196-01	175-3749-05
175-2529-02	175-2541-02	175-3750-05
175-2531-02	175-2542-02	175-3751-05
175-2543-02	175-2760-02	175-9718-01
175-2530-02	175-3024-02	175-7399-01
175-2532-02	175-3631-02	175-7400-01
175-2533-02	175-3633-02	175-7401-01
175-2534-02	175-3634-02	175-7402-01
175-2535-02	175-3635-02	175-7403-01
175-2761-02	175-9293-01	175-9295-01
175-9296-01		

Issue 15-12

49X/P VARIABLE RESOLUTION MODULE HOUSING

REF: M53931

The 49X/P Variable Resolution Module (A68/A69) housing has been modified to improve the circuit board housing ground contacts. Insufficient circuit isolation may result in distorted filter shapes and non-linear 1dB I.F. Gain Steps when weak signals are displayed in the 2dB/DIV Vertical Display mode. The new circuit board housing, P/N 380-0547-02 for V.R. #1, and P/N 380-0546-02 for V.R. #2, has a back plate which makes contact with the entire surface ground plane on the V.R. motherboards. The improved circuit board housings may be used as replacement parts in all previous 49X/P V.R. Modules.

As a result of this mod, the 49X/P Variable Resolution Module (A68/A69) part numbers have changed. The new modules will be used by FDI Manufacturing beginning with the following serial numbers:

- 492/P With Option 3 S/N B054895
Use 644-0531-00
- 492/P Non-Option 3 S/N B054895
Use 644-0532-00
- 492/P Option 6 S/N B621040
Use 644-0533-00
- 496/P S/N B021003
Use 644-0533-00
- 494/P S/N B010417
Use 644-0368-03

Issue 15-8

147A/148/149A RACKMOUNT TO CABINET CONVERSION

REF: 147A/149A Instruction Manual
P/N 070-2029-00

148 Instruction Manual
P/N 070-1266-00

148M Instruction manual
P/N 070-1807-00

Mod 57340

A rackmount to cabinet conversion kit is available for the 147/8/9 series instruments. Order P/N 040-0768-00. Issue 15-8

149A OPT. 1 HORIZONTAL TIMING BOARD REPLACEMENT

Ref: 149A Instruction Manual,
070-2029-00

Mod 57390

In order to provide a complete assembly for replacing the Horizontal Timing Board in a 149A Opt. 1, a new part number (672-0670-01) has been established.

672-0670-01 will consist of:

- 1 ea. 670-2040-06 Horiz. Timing ECB
- 1 ea. 179-1863-00 Wire Harness

Issue 15-10

110-S SERVICE MANUAL RE-WRITE

REF: 110-S Service Manual,
070-4423-01
Mod 57902

To obtain this new manual, order P/N 070-4423-01.

The Service Manual for the standard (non-TBC) 110-S Frame synchronizer has been rewritten, with much information added, changed, or corrected.

Issue 15-10

411X/412X/4170/4926/4041 WINCHESTER CONTROLLER HELPFUL HINTS

- Ref: 4170 Service Maintenance Information, November 25, 1985
- 4170 Service Manual P/N 070-7615-00
- 4110B MSIB Service Manual P/N 070-4811-00
- 4925/26 Instruction Manual P/N 070-4688-01
- 4926 Service Maintenance Information August 5, 1985
- 4926/4041 Option 3 Hard Disk Controller can Lockup MSIB/SCSI Bus W2 Issue 15- January 4, 1985

The Winchester controller board used in the 4110, 4120, 4170 and 4926 products, converts higher level commands to track and sector information so data may be stored on the 10 mega-byte Seagate Winchester (p/n 119-1644-XX). The Winchester controller is purchased from Xebec systems as a 119-1617-0X and used unmodified in the 856X products, and modified becoming p/n 670-8437-0X for use in the 41XX and 492X products.

The 670-8437-00 rolled to -01 when the wire jumper at board location 4J, to select a device address, changed to a double row of pins and a moveable jumper, see figure 1. Xebec rolled the board assembly number from 104526 to

104527 when they began to install the double row pins. Two other significant changes done by Xebec, when the board assembly number rolled, where straps W1 and W2 (which are not used by the field) where omitted and strap W3 got renomenclated to W2.

To maintain compatability with the 4041 and other SCSI bus interfaces, other than Option 45 (41XX MSIB interface) the 4926 Winchester controller rolled to 670-8437-02. This change is documented in the Wizard Workshop issue 15-1, article 4926/4041 Option 3 Hard Disk Can Lock Bus. The Option 45 interface is compatible with all three levels of the Winchester controller board 670-8437-00,01,02. Mass Storage Interface Bus (MSIB) is the Tektronix implementation of the ANSI Small Computer System Interface (SCSI).

STRAPPING

Configuring the Winchester controller is a matter of selecting the proper device address. The default device address is zero (0) as shown in the two exploded views on the Winchester controller board, figure 1. However, when connecting multiple devices, each device must be at a different device address. This requires the user to choose the device address. Device address 7 is always reserved for the host controller, such as the MSIB I/F (Option 45).

Sector size should be set for 512 bytes, strap W2 (on the 104526) or W2(on th- 104527) should be set at 5, as shown in Figure 1.

ARTICLE CONTINUED ON NEXT PAGE.....

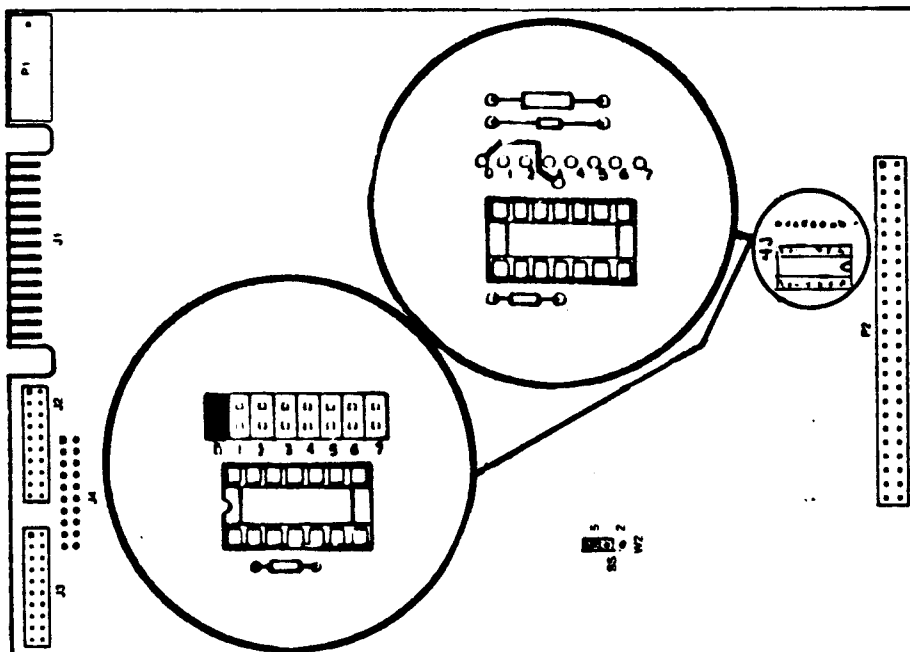

Figure 1

411X/412X/4170/4926

) TERMINATION

The Winchester controller should not terminate the SCSI bus, the resistor network terminator (IC5J) should always be removed.

Termination in the 4926 and 4926 Option 26 is accomplished by an internal terminator board which mounts on top of Winchester controller board.

For the 4925 or 4626 Option 25 termination is accomplished by the two terminator resistors R50 and R60 on the floppy disk controller board. If multiple units are employed only the last unit is to be terminated, with all other terminator boards or resistors removed.

The 4170 Option 3 and the M4115B and 412X Option 46/47 and the 61XX/62XX products use the 011-0090-00 external terminator for terminating the SCSI bus.

) 4170'S WITH MULTIPLE DEVICES

The 4170 requires devices to be connected in consecutive order starting at zero. If there are three devices on the buss, device address 0,1, and 2 must be selected. Failure to connect devices in consecutive order will result in a format program error. Address zero is reserved for Option 3, internal hard disk, if installed in the 4170.

Issue 15-13

This is caused by the build-up of static electricity and occurs mostly during the drier winter months.

There is now a new conductive coating for the frame sections that is silvery in color and shows a very low 10 ohm per inch resistance. Tests have shown this new silvery coating to be very effective in reducing static related problems.

The part number of the frame sections is unchanged and stock may be mixed for sometime.

This change has been implemented in manufacturing, but change over of the existing exchange inventory may take a while. If you suspect static problems, request a processor with the conductive silvery coating on frame sections.

Issue 15-10

463X PROCESSOR FRAME SECTION CONDUCTIVE COATING

REF: Corporate Mod 57135
Part Number 426-1043-XX
Part Number 426-1089-XX

The thermal processors in the 463X series of hard copies have been known to create phantom copies and jamming from random cutter clutch actuation.

520A SERIES CENTER DOT SHIFT

REF: 520A Instruction Manual
P/N 070-1709-00

521A Instruction Manual
P/N 070-1794-00

522A Instruction Manual
P/N 070-1874-00

Mod 57586

To address excessive center dot shift and vector overlay problems (A0/B0 ALT Mode), the 520A Series have been modified.

The change consists of adding a diode (P/N 152-0141-02) in series with CR512. The new part, designated CR518, is added by lifting the cathode of CR512, connecting the anode of CR518 to it, and then connecting the cathode of CR518 to the circuit board hole vacated by CR512.

This change can be made in the field to address the problems listed above.

Mod 57586 will be installed in new instruments from the factory with the following starting serial numbers:

520A	B540447
521A	B334695
522A	B160523

Issue 15-8

528 MOD 254 F/G HORIZONTAL POSITION POT

REF: 528 Instruction Manual,
070-0800-00

528 Mod 254 F/G Insert,
061-1585-00

Mod 56483

Due to clearance problems associated with the area near the Horizontal Position Pot in the 528 Mod 254 F/G, a new part has been established for replacement purposes.

For failures of R348, use P/N
311-0772-01.
Issue 15-10

528A INTENSITY LIMIT ADJUSTMENT

REF: 528A Instruction Manual,
070-3662-00

In order to provide a more uniform and usable Intensity range, the following procedure is suggested. This procedure is being used on the manufacturing line with good results, and will be incorporated into the product's manual at some later date.

Refer to Step 2 on page 4-30 of the 528A manual, and proceed as follows:

Step 2. Adjust Intensity Limit

- A. Turn Front Panel Intensity control fully CCW.
- B. Turn Intensity limit pot R448 fully CW.
- C. Measure voltage across R430 (should be about 0.200 volts).
- D. Turn Front Panel Intensity control fully CW.

ARTICLE CONTINUED ON NEXT PAGE

528A INTENSITY LIMIT ADJUSTMENT

Continued....

- E. Adjust Intensity Limit (R410) so that the voltage across R430 is 0.050 volts higher than what was measured in step C. (For Example: $.200 + .050 = .250$)
- F. Readjust Front Panel Intensity control for nominal (desired) display.

The procedure described will adjust the instrument for the CRT's designed cathode current spec. There may be some slight blooming at the extreme CW end of the Front Panel control, however, this should not be regarded as a defect.

Issue 15-11

1450-1 WIDEBAND AUDIO MOD

REF: 1450-1 Instruction Manual
P/N 070-2200-01

1450F20 Instruction Manual
P/N 070-5595-00

The instruction manual supplement that covers the changes that were made to the 1450-1 for wideband audio is available. This supplement is also being shipped with the wideband audio Field Upgrade Kits (1450F20).

Order P/N 070-5595-00 to obtain this supplement.
Issue 15-8

1410 SERIES MAIN CABLE MOD

REF: 1410 Instruction Manual
P/N 070-2779-00

1411 Instruction Manual
P/N 070-2322-00

1412 Instruction Manual
P/N 070-2323-00

Mod 54747

To help prevent problems associated with coaxial cable breakage, 3/4" sections of heat shrink tubing (P/N 162-0533-00) were added to the ends of the six 75ohm cables that are part of the main wiring harness, which became P/N 179-2467-01.

Mod 54747 will be installed in new 1410 Series mainframes starting with the following serial numbers:

1410 B030611
1411 B022745
1412 B020135

Issue 15-10

1420 SERIES INTENSITY LIMIT ADJUSTMENT

REF: 1420 Series Instruction Manual,
070-2899-00

In order to provide a more uniform and usable Intensity range, the following procedure is suggested. This procedure is being used on the manufacturing line with good results, and will be incorporated into the product manual at a later date.

Refer to Step 4 on page 5-18 of the 1420 manual, and proceed as follows:

Step 4. Adjust Intensity Limit

- A. Turn Front Panel Intensity control fully CCW.
- B. Turn Intensity limit pot (R410) fully CW.

(ARTICLE CONTINUED ON THE NEXT PAGE)

1420 SERIES INTENSITY LIMIT ADJUSTMENT (CONT.)

- C. Measure voltage across R3310 (should be about 0.160V).
- D. Turn Front Panel Intensity control fully CW.
- E. Adjust Intensity Limit (R410) so that the voltage across R3310 is 0.035 volts higher than what was measured in step C. (For Example: $.160 + .035 = .195$)
- F. Readjust Front Panel Intensity control for nominal (desired) display.

The procedure described will adjust the instrument for the CRT's designed cathode current spec. There may be some slight blooming at the extreme CW end of the Front Panel control, however, this should not be regarded as a defect.

Issue 15-11

1750 SERIES, DUAL DISPLAY UPGRADE

REF: 1750 Series Instruction Manual
P/N 070-5664-00
Mod 57122

The 1750 Series instrument has been upgraded to include a Dual Display feature (Simultaneous Waveform/Vector/SCH).

This feature is being installed in new instruments at the factory starting with S/N B030000.

Pre-B03 units can be upgraded using the following kits:

1750 040-1178-00
1751 040-1179-00

The new instrument manual (P/N 070-5664-00) can also be ordered through normal channels.

Issue 15-12

1750 SERIES HORIZONTAL JITTER

REF: 1750 Series Manual, 070-4472-00

1750 Series Manual, 070-5664-00

MOD 58567

Some instances of jitter in the Horizontal Sweep mode may be caused by the wrong voltage being fed from U300 to U400 when U300 is in a "non-sampling" mode.

To alleviate this problem, Mod 58567 installs a 4.7 M ohm resistor (P/N 315-0475-00) between pin 6 of U300 and +5 volts. An easy point to pick up +5 volts is the anode end of CR412.

Mod 58567 will be installed in the factory on new instruments with starting serial numbers of B030338 (1750) and B030139 (1751).

Issue 15-14

1750 SERIES INCONSISTENT LOCK-UP

REF: 1750 Series Instruction Manual
P/N 070-4472-00
Mod 55904

In order to address inconsistent lock-up problems in the Subcarrier to Horizontal Mode, the Subcarrier to Waveform Mode, and the R-Y Mode, the 1750 and 1751 have been modified.

In the 1750, A9U309 has been changed to P/N 160-2343-01.

In the 1751, A9U276 has been changed to P/N 160-2348-01 and A9U309 has been changed to P/N 160-2349-01. These two

IC's are available as a Field Replacement Kit, P/N 050-2053-00.

Mod 55904 will be installed in new instruments from the factory starting with S/N B020240 in the 1750, and S/N B020134 in the 1751.

Issue 15-8

4014, 4015, 4081, 619 YOKE ASSEMBLY

The yoke for these units does not come with connectors attached. Part Number 119-0502-00 is now set-up by Corporate mod 58301 and it includes the yoke with connectors and holders as a unit.

Issue 15-13

4100F42/F43 OPTION 01 CORRECTIONS

Ref: 4100F42/F43 Option 01
Installation Procedures,
070-5008-00

The following corrections should be made only to the 4100F42/F43 Option 01 Installation Procedures, 070-5008-00, first printing, FEB 1984.

- * On page one, under the Introduction section add an "M" in front of the 4115B Electronics Module.
- * On pages two thru sixteen, Option 02 should be changed to Option 01, in the bottom page subtitles.
- * On page eight, under step 10, change "seven to six" and in figure 10, cross out the lower left arrow and change "(7)" to "(6)".

ARTICLE CONTINUED ON NEXT PAGE

4100F42/F43 OPTION 01 CORRECTIONS
(CONT.)

- * On page ten, cross out step 5 and cross out figure 14. These Disk Drive Drawer Locks have been deleted from the F42/F43 kit.
- * On page eleven, the instructions in step 7 should be crossed out and written after step 12, on page 13.
- * On page sixteen, in step 21, change "power cables" to "power cable" add "to J7" after "disk drive drawer".
- * In figure 26, add "J7-Disk Power Cable" below "Ground Wire" and draw an arrow pointing to J7 on the power supply (located approximately to the left from the center of the power supply).

These changes will be incorporated in the next revision of the 4100F42/43 Option 01 Installation Procedures, 070-5008-00.

Issue 15-11

4109/CX LVPS MODIFICATION 53927

Ref: 4109/CX Service Manual,
070-4890-01
GMA301 Service Manual,
070-5122-00

The monitor low voltage power supply in the 4109/CX and GMA301 has recently been modified by engineering change order 53927 to improve reliability. The emphasis of the change is to accomodate a greater range of specifications for the 156-0430-00 optoisolator at U625, but a number of other parts are affected.

The symptoms of optoisolator failure are poor secondary regulation, loss of voltage during operation, or failure of the supply to come up at all.

An 040-1159-00 parts replacement kit has been created for installing the modification into supplies in the field.

Issue 15-9

4112X/4113X/4114X/4116X MOTHERBOARD KEYS

There have been some reports that the motherboard keys are being smashed into the motherboard connector when circuit boards are plugged in. This may cause damage to the pins in the connector, where it is no longer functional. If you experience difficulty with the motherboard keys, feel free to remove them.

By removing the keys, the service specialist will have to be careful to eliminate damage to boards by placing them in designated slots. The following figure shows board placement in the instrument as shipped from the factory.

ECB LOCATION 4112			
1	3PP1 (OPT.)	6	PROCESSOR
2	RAM/ROM	7	MASS STORAGE
3	TABLET (OPT.)	8	VIDEO CONTROLLER
4	RAM (OPT.)	9	EXTERNAL VIDEO
5	RAM (OPT.)	10	VECTOR GENERATOR
11		12	DUAL RASTER MEM
			RASTER MEM

ECB LOCATION 4113			
1	MASS STORAGE (OPT.)	7	RAM (OPT.)
2	PROCESSOR	8	RAM (OPT.)
3	3PP1 (OPT.)	9	RAM (OPT.)
4	TABLET (OPT.)	10	VIDEO CONTROLLER
5	RAM/ROM	11	EXTERNAL VIDEO (OPT.)
6	COLOR COPIER (OPT.)	12	DUAL RASTER MEM
		13	RASTER MEM (DUAL)
		14	VECTOR GENERATOR
		15	COLOR MAP

ECB LOCATION 4114/4116			
1	MASS STORAGE (RAM/ROM)	6	RAM
2	PROCESSOR	7	TABLET
3	3PP1/TABLET (RAM/ROM)	8	RAM
4	DISPLAY CONTROLLER	9	RAM
5	VECTOR GENERATOR	10	RAM/ROM
		11	RAM
		12	RAM
		13	RAM
		14	RAM
		15	RAM

Issue 15-10

4115B/4120 SERIES OPTION 9/19 ERROR
CODES NOT DOCUMENTED

REF: 4110/4120 Series Command
Reference Manual, 070-3892-02

4110/4120 Series Command
Reference With 3D Manual,
070-5141-00

Terminal System Error TPO0: and M@66: are not documented for Option 9/19. Terminal System Error TPO0: can occur with Version 4 Firmware in the Option 9/19 and Terminal System Error M@66: can occur with Version 5 Firmware. Both of these error codes mean OUT OF MEMORY and can occur after the terminal is commanded to do a copy to a 4691, 4692, or 4695. If Terminal System Error TPO0: or M@66: does occur, the user should reduce the size of the dialog buffer. If the user is in LOPRO, the RAM command can be used to reserve more memory for terminal firmware functions.

Issue 15-9

4510 RS-232 HARDWARE FLAGGING

The 4510 RS-232C input uses Data Terminal Ready (DTR) to flag transmission from the host computer, terminal or modem. The choice was made to achieve compatibility with 410X Series terminals.

Because of a firmware oversight, DTR from the 4510 is not always held high when software flagging (DC1/DC3) is enabled. Thus connection to a host computer through a modem, utilizing software flagging to the host, will result in hung communications. The modem inhibits communications whenever it detects the absence of a "high" DTR signal.

A firmware (new ROM) solution will not be available for many months. To get your customers operating, add a custom

connector or modify the RS-232 cable to achieve the following: At the 4510 end, remove the wire from pin 20 and connect it to pin 4. Label this end of the cable "4510" so no one will get it reversed. This connects the DTR line to the RTS pull-up within the 4510.
Issue 15-8

4631/4632 HEATER CONTROL CABLE IMPROVED

REF: Corporate Mod 57296

The cable assembly that connects the thermal processor heat control to the circuit board has a history of disconnecting from the board during shipment.

A new cable assembly part number 175-3681-01 has been developed and the mod re-routes the cable upward and across to the heat control. The heat shrink has been removed and the connector is a self-locking type.

Issue 15-13

4632 COPY DISTORTION PROBLEM

Recent discoveries in manufacturing have shown that a 4632 may cause some distortion of the copies. This appears on the copy as a variation in the thickness of the scan line and it may appear to look like line pairing unless a close examination is done. Because of the distortion, some copies may also be out of focus.

The cause is oscillations within the Z-axis circuitry. The fix is to move the timing board to the most forward slot on the main board. This eliminates the oscillations and also allows for improved air flow thru the circuit card area. All units are now being shipped with the timing card installed in the forward slot.

ARTICLE CONTINUED ON NEXT PAGE

4632 COPY DISTORTION PROBLEM
(continued)

Please move the timing card to the forward slot when performing service on a 4632.

Issue 15-10

4692: POWER SUPPLY DAMAGE HAZARD

REF: Serv. Man. 070-4815-00

A recently returned Drive Module was severely damaged, apparently because a loosened Interconnect Board was allowed to short against the metal top of the ink cartridge chassis, with power cord connected.

Be aware that the +28V unregulated power supply is always "hot" when the power cord is connected, and +28V is routed to 3 solenoids and the wash pump, even with power OFF. Disassembly/assembly should always be performed with power disconnected.

Issue 15-14

4907 FIRMWARE 1.4 OPERATING CHARACTERISTICS

When updating the 4907 firmware to level 1.4, you will notice on power-up that the heads on all drives cycle in and out. This is a change from other firmware levels, but it is a normal operation for level 1.4.

Issue 15-13

4695: JETS CLOGGED/ERRATIC DOTS CAUSED BY THICK INK AND LOW COPIER USAGE

Recent reports of clogged jets or erratic dot position may be caused by the natural thickening of ink as water evaporates from the ink reservoirs. This will occur when a copier is used very little, or when it has been stored for several months. It can also occur when a particular color is used infrequently.

To identify a thick ink problem, wash the head using the washing tool and maintenance liquid. Make a few lines of test pattern and note if erratic dot position or "the clog" was fixed. If it was, activate the PURGE twice and repeat the test pattern. If the problem returns, it is necessary to dilute the ink.

Remove the cartridge(s) for whichever color(s) exhibit(s) the problem and add 1 cc. (25 drops) of maintenance liquid to the ink reservoir. Cycle power three times to "shake up" the ink, mixing the dilutant. Perform 3 electronic purges to flush the thick ink out of the head passages and draw in the dilute ink. Run a test pattern to check the result. NOTE: the simple addition of fresh ink has proven ineffective!

Issue 15-14

4909 HEAD CRASH CHECK

One of the most complicated problems that can occur with a 4909 is a fixed head crash, and yet this is one of the hardest problems to diagnose. System faults, read error and screeching noises are all symptoms of a fixed head crash, but it would be easier if there was a simple way of identifying a fixed head crash without having to disassemble the disk.

An easy way to do this is to slide the disk drive out, remove the drive cover, and remove the cartridge disk. With the door of the drive open, the hole on the left side of the removable disk chamber is exposed (coming up from the absolute filter). With this hole exposed, an angled dentists mirror (one that pivots works the best) can be inserted down into the hole. By shining a penlight onto the mirror (and with a little careful manipulation) all of the surfaces of the fixed disk can be examined for marks or scratches.

This can be done by any technician, requires no major disassembly, and in most cases will allow determination if a head crash occurred. This may eliminate pushing the panic button over a head crash before the panic mode is really necessary.

Issue 15-10

4692 T.V. PATTERN GENERATOR CABLE MOD

REF: 067-1204-00 Test Fixture
070-5123-00 Service Manual

The ribbon cable from the T.V. Pattern Generator is polarized at the 4692 end to prevent reversal. Unfortunately we failed to polarize it at the other end and it can still be reversed, which typically blows two axial lead fuses, F851 and F855 (P/N 159-0090-00), on the 4692 Drive Module.

To prevent this occurrence, you can easily polarize the plug at the test fixture end. Use a needle-nose pliers to "wobble" and break off pin 1 at the test fixture. Insert a plug, P/N 134-0153-00, into pin 1 on the ribbon cable (it is marked with an arrow and is on the red stripe side). See the figure below.

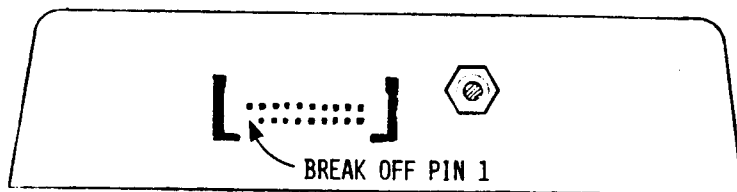

T.V. Pattern Generator Connector

Issue 15-8

7612D POWER SUPPLY (-5.2V) ADJUSTMENT

REF: 7612D Instruction Manual
(070-2387 00) Adjustment/Performance
Check, Step A2 (Check/Adjust -5.2vdc)

It has been brought to my attention that for convenience, this adjustment is occasionally performed by monitoring the voltage at the power supply terminal posts instead of J500 pins 4 and 5, as outlined by the manual. If performed in this fashion, the actual voltage received by circuits utilizing this supply is considerably lower than it should be (approx. -5.0vdc).

Therefore, in order to prevent this concern, the procedure used in the manual should be adhered to when performing this adjustment.

Issue 15-13

016-0596-0X RGB MIXER FUSE CHANGE

Ref: Manual part#070-4719-00
Corporate MOD 57876

Problem: Fuses blowing under normal
operating conditions

The RGB mixer fuse rating is very close to its operating current and will open after extended operation. The fuse is changed by Corporate MOD 57876 from a .031 AMP fast-blow to a .062 (1/16) AMP slow-blow part number **159-0051-00**. New labels to cover the present fuse rating label are available under part number 334-4565-00.

Please change the fuse when servicing the mixer.

Issue 15-8

DESCRIPTION**TEXT and ILLUSTRATION CHANGES****Page 3****ADDITIONAL TEST EQUIPMENT FOR CALIBRATION PROCEDURE,****ADD:**

4. Spectrum Analyzer
Required for Option AB, not optional

CHANGE 21. Locally constructed BCD color bar selection box TO READ:

21. Locally constructed BCD color bar selection box.
(See Fig. 1a for schematic and part numbers)

ADD:

22. Locally constructed source selection switch box.
(See Fig. 1b for schematic and part numbers)

CALIBRATION PROCEDURE**CHANGE Step 16, part a TO READ:**

- a. Remove the Color Bar Logic board (A32) from the TSG7 and lift pin 19 of U172, pins 3 and 11 of U152, and pin 3 of U147. To avoid damage to the ICs, do not bend the IC leads. Insert the ICs into extra sockets, bend the appropriate leads on the socket, and insert IC's & sockets into the sockets on the board. Remove U179 and replace with the plug from the BCD switch box. Replace the Color Bar Logic Board.

Page 4**CHANGE Step 16, part d TO READ:**

- d. Connect the Fluke 5200A with 75 ohm series resistor, the TSG7, and the source switch as shown in Fig. 2. Select the Fluke 5200A with the source switch box.

DESCRIPTION

CHANGE Fig. 1 AS FOLLOWS:

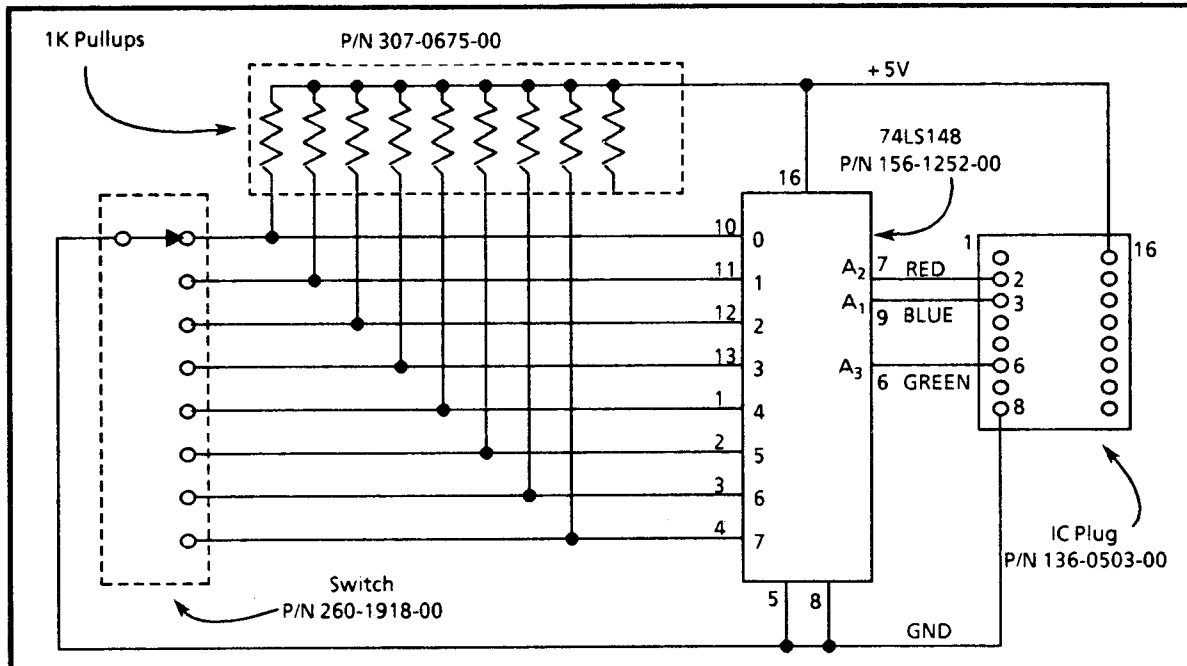

A) Schematic Diagram for BCD Color Bar Selection Box

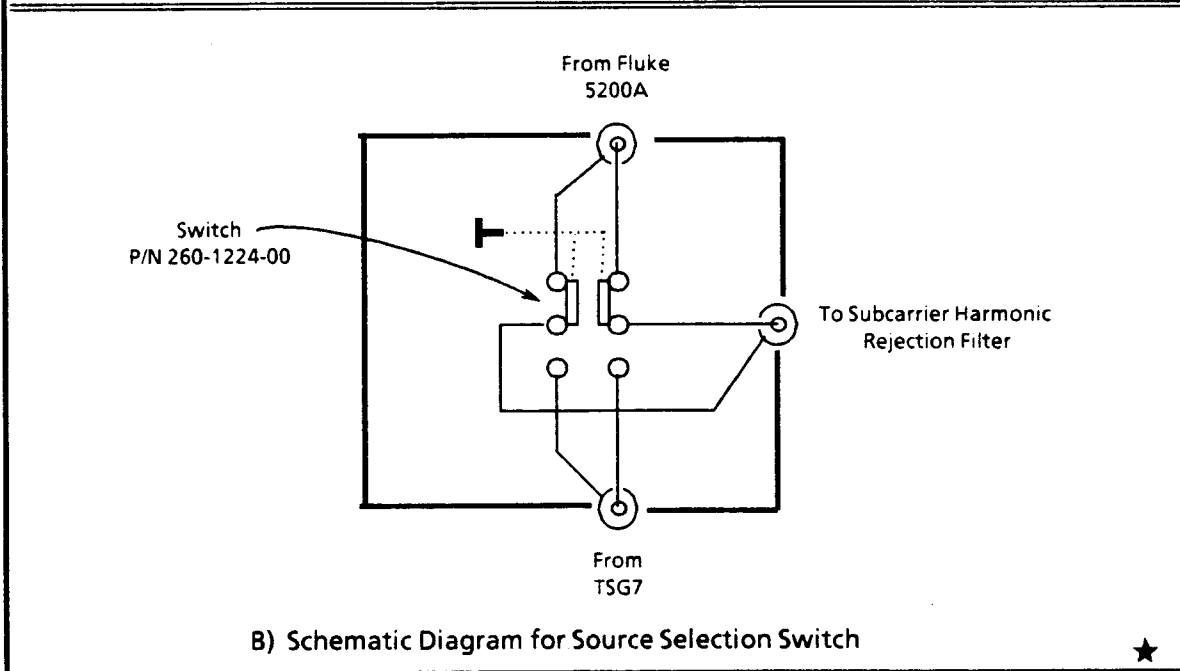

B) Schematic Diagram for Source Selection Switch



Fig. 1. Schematics for locally constructed test equipment

DESCRIPTION

CHANGE Table 3 TO READ:

Table 3
Output Voltage From Fluke 5200A

BAR	R-Y Vrms (mv)	B-Y rms (mv)	CHROMA Vrms (mv)
Yellow, Blue	69.9 ^{a,b}	306.25	312.7
Cyan, Red	433.4	103.45 ^b	445.5
Green, Magenta	363.4	202.8	416.1

^a In the 100 mV range, the Fluke 5200A output will be affected by the finite value of the load resistance. To overcome this, use the DM501 (Ac mode) to measure the Fluke's unterminated output, then insert the 75Ω feed-through and adjust the Fluke so that the DM501 reading is the same as when unterminated.

^b On these settings it may not be possible to zero the DVM within 100 mV. Null as best as possible.

CHANGE Step 16, parts g, h, & i TO READ:

g. Select the TSG7 with the source switch (see Fig. 2). Do not readjust the p-p detector level control. Set the BCD switch to the appropriate bar (Red, Green, or Blue).

h. CHECK/ADJUST - R-Y chrominance amplitudes (adjust with R249 Red, R258 Green, or R248 Blue) so the DVM reading is the same as the reading noted in step f within the voltage range listed in Table 4. Repeat parts e, g, and h until adjustments on Red, Green, and Blue have been completed.

i. CHECK/ADJUST - for less than 0.5 mV subcarrier on the white bar (See Fig. 3 for equipment connection diagram; oscilloscope at 1 mV, full bandwidth, trigger source - left). Adjust R249 to set the subcarrier amplitude to read 5 mV on the oscilloscope, and note the residual subcarrier level on the spectrum analyzer. Adjust R249 for minimum residual amplitude, and check that it is at least 20 dB down from the original level.

Page 5**CHANGE Step 16 part k. TO READ:**

k. Select the TSG7 with the source switch (see Fig. 2). Set the BCD switch to the appropriate bar (Red, Green, or Blue).

CHANGE Step 16 part m. TO READ:

m. Select the Fluke 5200A with the switch. Set the output voltage for the Red R-Y bar (see Table 4).

DESCRIPTION

CHANGE Figs. 2 and 3 AS FOLLOWS:

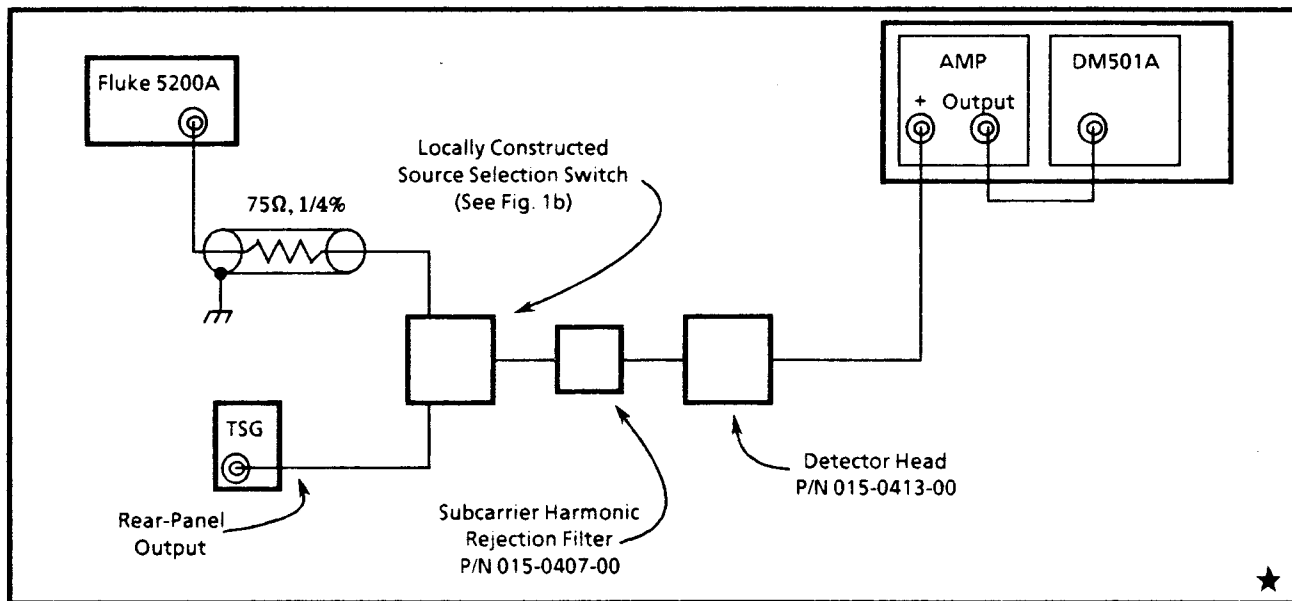

Fig. 2. Equipment Connections for Chrominance Amplitude Measurement.

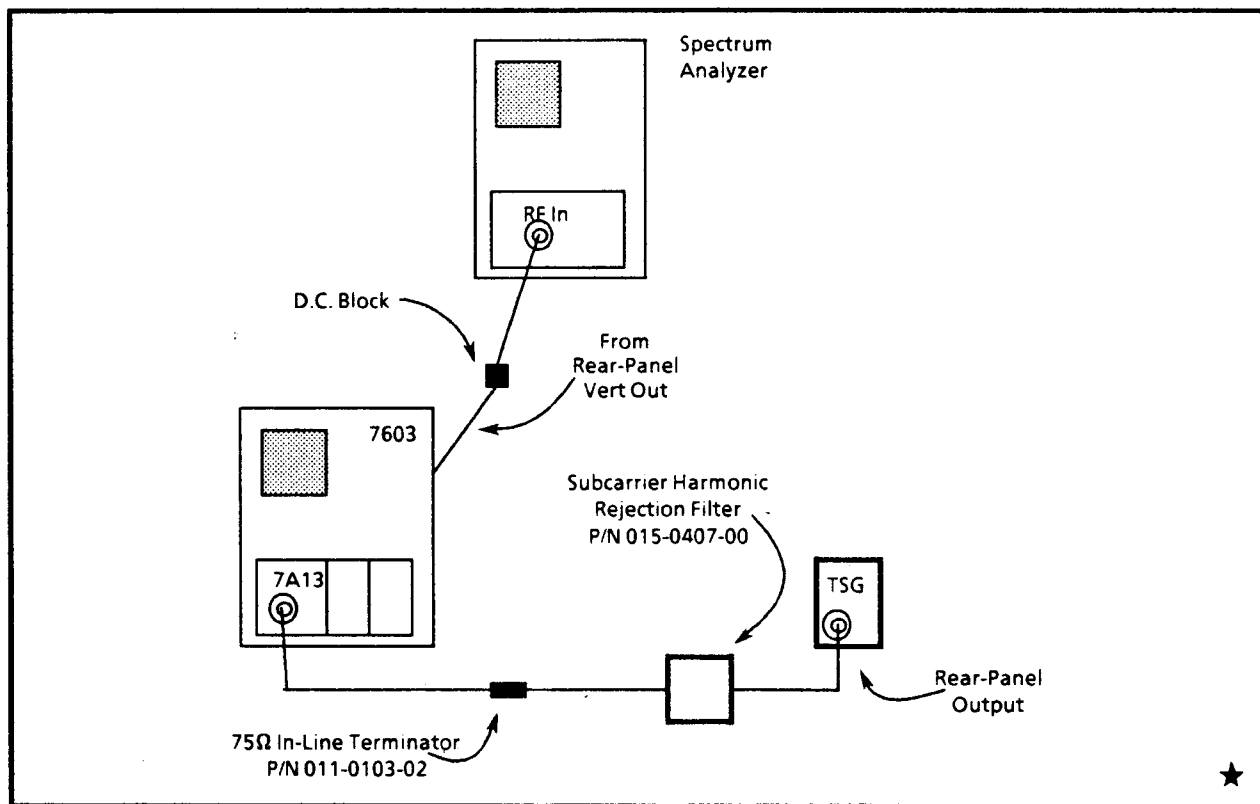

Fig. 3. Equipment Connections for Residual Chrominance Measurement.

DESCRIPTION

Page 6**CHANGE Step 16 part r. TO READ:**

- r. Check for no subcarrier on the white bar with the procedure of step i, using R219 (Blue).

ADD Step 16 part u.:

- u. Return the Tolerance Control on the Fluke 5200A to 0%.

ADD Step 17 part c.:

- c. Remove the Color Bar Logic board (A32) from the TSG7. Remove the BCD switch box, and replace U179. Remove the extra sockets on U147, U152, and U172. Replace the Color Bar Logic board.

The Tektronix Service Organization firmly supports a policy of assuring continued utility of products sold by Tektronix.

This publication is meant to provide technical information to the customer who has decided to maintain his own Tektronix products. It contains product servicing information and is written for the technician.

Articles are submitted primarily by Corporate Service Support & Planning Personnel thoroughly familiar with the products they support. SERVICE TEKNOTES also encourages you to submit articles for publication. If you have knowledge of a technique, procedure or idea that enables you to service your Tektronix product more effectively, write it down so others may benefit from your experience.

Articles for publication should be submitted directly to:

Tektronix, Inc.
P.O. Box 500
Beaverton, Oregon 97077

Attention: Mary Ellen Zander
SERVICE TEKNOTES Editor

Delivery Station: 53-102

The Editor and staff of SERVICE TEKNOTES provide the material in this publication as a service to users of Tektronix Products. While we have tried to be diligent in assuring the accuracy of the material which we have printed, we cannot guarantee its accuracy. Neither SERVICE TEKNOTES, its editor and staff, Tektronix, Inc., nor its representatives assume any responsibility for the use of the material printed in SERVICE TEKNOTES; nor can we assume any responsibility for any errors or for the resulting effects of any errors.

SERVICE TEKNOTES is distributed by Service Administrative Support free of charge to customers who maintain their own Tektronix equipment. A customer may be added to the distribution list by applying through his local Tektronix Sales Engineer.

Copyright ©1981, Tektronix, Inc. All rights reserved. Printed in U.S.A. Tektronix products are covered by U.S. and foreign patents, issued and pending. Information in this publication supersedes that in all previously published material. Specification and price change privileges reserved. TEKTRONIX, TEK, SCOPE-MOBILE, and ~~TELE~~ are registered trademarks of Tektronix, Inc. TELEQUIPMENT is a registered trademark of Tektronix U.K. Limited.