

CATHODE-RAY OSCILLOSCOPE TYPE 315D

SERIAL NUMBER _____

INSTRUCTION MANUAL



MANUFACTURERS OF CATHODE-RAY AND VIDEO TEST INSTRUMENTS

Sunset Highway and Barnes Road • P. O. Box 831 • Portland 7, Oregon, U. S. A.
Phone: Cypres 2-2611 • Cables: Tektronix

SECTION I

General Description

The TEKTRONIX Type 315D cathode-ray oscilloscope is a small compact and portable high-performance laboratory instrument particularly designed to occupy minimum space. The vertical bandwidth extends to five megacycles from dc. Time-base ranges extending from one microsecond per sweep to fifty cycles per sweep are provided. An amplitude calibrator and a time-base magnifier are also included.

SENSITIVITY

Twelve calibrated fixed sensitivities: ac only, 0.01, 0.02 and 0.05 volts per division, 5 cycles to 5 megacycles: dc and ac 0.1, 0.2, 0.5, 1, 2, 5, 10, 20, and 50 volts per division. These sensitivities fit graticule divisions for direct reading of voltages. Continuously variable 10 to 1 sensitivity multiplier control also available.

CALIBRATOR

Square wave at approximately one kilocycle available at front-panel UHF connector at four fixed peak-to-peak voltages of 0.1, 1, 10, and 100 volts with accuracy within 3 per cent.

SIGNAL DELAY

Quarter-microsecond signal delay line permits all of the triggering waveform to be viewed.

TRIGGER AMPLITUDE DISCRIMINATOR

Permits time base to be triggered at any desired amplitude point on the triggering waveform.

TIME BASE

Twenty-four fixed times per division between 0.1 microsecond and 5 seconds per division fit graticule divisions for direct reading of time. Continuously variable 10 to 1 sweep-time control also available.

TIME BASE MAGNIFIER

Magnifies time base to right and left of center by factor of five times. Portion of trace appearing at center is made five times as wide.

DIRECT-COUPLED UNBLANKING

Accommodates slowest sweeps.

CATHODE-RAY TUBE

Flat-faced high definition three-inch tube.

GRATICULE

Quarter-inch divisions, 8 lines vertically, 10 lines horizontally. Variable-intensity edge lighting.

POWER SUPPLY

Four electronically regulated plate-voltage supplies. Power transformer will operate on either 117 or 234 volts, 50 to 800 cycles. (Special ventilating fan required for other than 50- to 60-cycle operation.)

CRT ACCELERATING VOLTAGE

1630 volts from electronically regulated rf oscillator high-voltage supply.

VENTILATING FAN

The Type 315D is normally supplied with a 50- to 60-cycle induction-motor fan. For frequencies much above 60 cycles a dc commutator motor and selenium rectifier are available at extra cost to extend the range to 800 cycles.

DIMENSIONS

12 $\frac{3}{8}$ " high, 8 $\frac{5}{8}$ " wide and 18 $\frac{1}{4}$ " long.

WEIGHT

36 lbs.

CONSTRUCTION

Welded aluminum alloy.

FINISH

Anodized photo-etched aluminum panel, grey crackle enamel case.

Functions of Front-Panel Terminals and Controls

VERTICAL AMPLIFIER

MULTIPLIER	Four-position switch to multiply VOLTS/DIVISION by factors of 1, 2, or 5. Fourth position marked 10-1 in red permits red coaxial knob to adjust multiplier continuously over 10 to 1 range.
INPUT	Coaxial UHF connector for connecting signal to vertical-deflection system.
AMPLITUDE	Seven-position control provides four fixed ac sensitivities and three fixed dc sensitivities.
FOCUS	Adjusts voltage of focusing anode to provide focusing.
INTENSITY	Adjusts control-grid voltage to control brightness of trace.
SCALE ILLUM	Adjustable series resistor in graticule lighting circuit to control amount of scale illumination.
POSITION HORIZ.	Adjusts average voltage of horizontal deflection plates to position trace horizontally.
VERT.	Adjusts average voltage of vertical deflection plates to position trace vertically.
TIME BASE MULTIPLIER	Four-position switch to multiply time-base TIME/DIVISION by factors of 1, 2, or 5. Fourth position marked 10-1 in red permits red coaxial knob to adjust multiplier continuously over 10 to 1 range.
RANGE	Eight-position switch provides eight fixed time base times per division in decade ratio between 0.1 microsecond per division to 1 second per division.

5X MAGNIFIER (Red label, red knob)	Two-position switch turns time-base magnifier on in clockwise position, returns time base to normal in counterclockwise position.
CALIBRATOR	Five-position switch selects four fixed peak-to-peak squarewave voltages of 0.1, 1, 10, or 100 volts. Turns calibrator oscillator off in fifth position.
TRIGGER SELECTOR	Ten-position switch selects trigger source and accommodates trigger circuits to rising or falling trigger waveforms. Accommodates trigger circuits to fast-rising or slow-rising triggering waveforms.
STABILITY (Red label, red knob)	Adjusts voltages of gating multivibrator so that it can be set for recurrent operation or at the threshold of recurrent operation for triggered sweeps.
TRIGGER AMPLITUDE DISCRIMI- NATOR	Continuously variable voltage control determines point of operation of trigger-inverter stage to select point on triggering waveform at which time-base circuit is tripped.
POWER ON CAL OUT	AC supply off-on toggle switch. Coaxial UHF connector for output of calibrator oscillator.
EXT TRIGGER AC Binding Post	Connects to EXT. positions of TRIGGER SELECTOR switch through capacitor.
DC Binding Post	Connects directly to EXT. positions of TRIGGER SELECTOR switch.
+GATE	Binding post provides 25-volt positive gating pulse coincident with time base.
SAWTOOTH	Binding post provides positive-going sawtooth voltage coincident with time base.
GND	Binding post connected to frame of instrument.

SECTION II

Operating Instructions

The TEKTRONIX Type 315 Oscilloscope may be operated in any indoor location or in the open if it is protected from moisture.

VENTILATION

Forced-air cooling is required so that care must be taken to avoid obstructing the air intake to the circulating fan.

WARNING: The Type 315D Oscilloscope should not be operated unless the fan is running. The interior will reach dangerous temperatures within five to ten minutes of such operation.

The operation of the calibrator and the trigger circuits of the Type 315 oscilloscope is enough different that it is especially important for users familiar with previous TEKTRONIX oscilloscopes to understand the difference.

The vertical amplifier is sufficiently stable that once the gain has been standardized, voltages can be read directly from the graticule just as you would read a voltmeter. For this reason, the calibrator in the Type 315 is not continuously variable in amplitude as are the calibrators in previous TEKTRONIX oscilloscopes. The calibrator is intended to be used as a source of squarewave voltage, operating in the vicinity of one kilocycle, available at four accurate fixed voltage levels, 0.1, 1, 10, and 100 volts, peak to peak. It is useful to supply a signal for aligning the vertical amplifier, and the attenuator and probe, as well as for standardizing the gain of the vertical amplifier to the graticule calibrations.

To check the calibration of the vertical amplifier, make a connection between the CAL OUT terminal and the INPUT terminal. Then, for example, set the VERTICAL AMPLIFIER MULTIPLIER selector to 2, the AMPLITUDE selector to DC, 0.1, and the CALIBRATOR to 1 volt, peak to peak. With these settings, there should be exactly five graticule divisions deflection of the trace. The amplifier gain can

be corrected for any difference by means of a screwdriver adjustment in the center of the AMPLITUDE selector switch.

To use the Type 315 for making an amplitude measurement, place the AMPLITUDE selector in the approximate range of sensitivity desired, and the MULTIPLIER selector on any one of the three steps, 1, 2, or 5. Each division of the graticule then corresponds to a voltage which can be determined directly by multiplying the AMPLITUDE and the MULTIPLIER scale readings.

In the most counter-clockwise position of the MULTIPLIER selector, a continuously-variable gain is provided over a range of 10 to 1, marked in red. In this selector position, varying the red knob mounted coaxially with the AMPLITUDE selector knob varies the gain over the 10 to 1 range.

In addition to the coaxial red knob on the AMPLITUDE selector switch, there are three other red knobs mounted in a like manner on the TIME BASE and TRIGGER controls. In each case, a red scale on the panel pertains to the position or to the function of the red knob.

In the operation of the time base of the Type 315 oscilloscope, the TRIGGER AMPLITUDE DISCRIMINATOR control is likely to be somewhat confusing to users familiar with previous TEKTRONIX instruments. This control is not in any sense a trigger amplitude adjustment. The triggering circuit is direct coupled to the vertical amplifier in the INT positions of the TRIGGER SELECTOR switch, both for the AC and DC connections of the vertical amplifier and is direct coupled to one of the EXT TRIGGER panel connectors. The TRIGGER AMPLITUDE DISCRIMINATOR control determines by amplitude the portion of the triggering waveform at which triggering occurs. At settings of the DISCRIMINATOR control near zero, triggering will occur at a point on the waveform near zero. If the zero signal trace is centered on the screen, triggering will occur at a point on the trace above the center of the screen. Regardless of the amplitude of the waveform, triggering will occur at a point on the trace the same distance above the center of the screen, provided that the wave reaches that amplitude. The negative trigger positions of the TRIGGER SELECTOR control refer to the direction of slope of the triggering waveform at which triggering occurs. For example, to trigger the sweep from a sine wave at a point beyond the peak but above zero, the TRIGGER SELECTOR should be placed in one of the negative trigger positions and the TRIGGER AMPLITUDE DISCRIMINATOR should be turned to a positive position.

For slow rise signals whose rise time is longer than

one microsecond, the TRIGGER SELECTOR should be placed in one of the SLOW RISE positions of the scale. In these positions of the control, a regenerative trigger generator produces sharp triggers suitable for initiating the sweep regardless of the rise time of the input wave. For the FAST RISE positions, the trigger generator is not regenerative and is capable of producing faster triggers so that for high frequency or fast rise time signals, the TRIGGER SELECTOR switch should be in one of these positions. The best way to determine which position is proper for a marginal type of signal is to try both positions. There is appreciable overlap.

Generally speaking, there is no difference in trigger sensitivity in the different control positions. A change in voltage which will produce a quarter of a division deflection, will easily initiate a trigger at any speed or in any part of the wave. For a small amplitude wave, the TRIGGER DISCRIMINATOR control will need to be set near zero. With settings near maximum either clockwise or counterclockwise, a large trace will be required to initiate a sweep and the point of initiation will be near the top or bottom of the waveform.

Calibrations on the DISCRIMINATOR dial are approximately in volts for externally connected trigger voltages. For internally derived triggers, approximately seven divisions on the DISCRIMINATOR scale corresponds to about ten graticule divisions of deflection.

The magnifier circuit expands to right and left the portion of the trace that is centered on the screen. Horizontal positioning precedes the magnifier circuits so that this control is used for both the normal and magnified trace.

PLACING THE TYPE 315D OSCILLOSCOPE IN OPERATION FOR THE FIRST TIME

The following procedure is suggested when you put the instrument into service for the first time:

1. Set the panel controls as follows:

POWER OFF
 VERTICAL AMPLIFIER MULTIPLIER..2
 VERTICAL AMPLIFIER
 AMPLITUDE.DC, 0.1 VOLTS/DIVISION
 FOCUSCENTER
 INTENSITYCOUNTERCLOCKWISE
 SCALE ILLUM.....CENTER

HORIZ. POSITION.....CENTER
 VERT. POSITION.....CENTER
 TIME BASE MULTIPLIER.....1
 TIME BASE RANGE.....1 MILLISEC.
 CALIBRATOR.....1 VOLT
 TRIGGER SELECTOR.SLOW RISE, +INT.
 STABILITYCOUNTERCLOCKWISE
 TRIGGER AMPLITUDE
 DISCRIMINATOR —50

2. Connect the power cord to a source of ac power capable of supplying 4 amperes at 117 volts at 60 cps. (240 volts if power transformer is so connected, and 50 to 800 cps for the universal-frequency model.)
3. Make a connection between the CAL OUT terminal and the INPUT terminal. Turn the POWER switch to ON, and permit the instrument to warm up for about a minute.
4. Advance the INTENSITY control clockwise a little past center.
5. Advance the STABILITY control until a trace appears on the screen.
6. Adjust the FOCUS and INTENSITY controls for a sharp trace and satisfactory brightness.
7. Adjust the two POSITION controls until the trace is centered on the screen as desired.
8. Return the STABILITY control clockwise until the trace just disappears and return the TRIGGER AMPLITUDE DISCRIMINATOR control clockwise toward 0 until the calibrator waveform appears on the screen.

The stability control determines whether the multi-vibrator retriggers itself or whether it returns to a stable condition after executing a single sweep for each trigger received.

In the SLOW RISE positions of the TRIGGER SELECTOR switch the regenerative trigger generator produces triggers of the same amplitude when tripped regardless of the amplitude or speed of the triggering waveform. The STABILITY control should therefore be set at such a level that a trigger output of this amplitude will trigger the sweep and thereafter no change in the STABILITY control setting will be needed. The trigger sensitivity is the voltage difference needed to trip the regenerative trigger

generator, which is determined by the gain between halves of this generator. There is no front-panel control of this gain, but there is an internal screwdriver adjustment which should not be changed, however, except possibly after replacing the generator tube.

In the FAST RISE positions of the TRIGGER SELECTOR switch regeneration between the halves of the trigger-generator tube is effectively removed by shorting out the plate-load resistor of the input pentode section. Since the circuit thus becomes a cathode-coupled amplifier, the amplitude of the out-

put triggers is dependent on the differentiated rise of the triggering waveform. For slow-rising waveforms, therefore, the output trigger will be too small to trip the time-base generator. The point of transition at which better triggering will result from one or the other of the switch positions is not critical. For rise-times near one microsecond it will be well to try both types of operation. Triggering from the calibrator waveform will be more satisfactory with the TRIGGER SELECTOR switch in the SLOW RISE positions.

SECTION III

Circuit Description

SWEEP CIRCUIT

The time base of the TYPE 315 CATHODE-RAY OSCILLOSCOPE is generated by means of a Miller runup generator. New circuitry eliminates the usual distortion of the early part of the sawtooth. A constant current charging source to the timing capacitor improves the sawtooth linearity.

The triggering signal is selected by means of the TRIGGER SELECTOR switch connected to the B section of a cathode-coupled phase inverter, V201, with a gain of about six at each plate. The A section grid is connected to the arm of a potentiometer so that its bias can be varied over a wide range. By adjusting the bias properly you can select the portion of the triggering wave form that triggers the sweep.

A second section of the trigger selector switch connects the output of B section plate to the trigger generator, V202, for negative-going triggering waveforms and the A section plate for positive-going triggering waveforms.

The trigger generator consists of V202, as a bistable multivibrator for slow-risetime trigger signals, and as a cathode-coupled amplifier for fast-risetime trigger signals. For signals with a risetime slower than one microsecond, the multivibrator circuit will provide the best trigger signal. In the SLOW RISE positions of the TRIGGER SELECTOR switch, SW201, C227 connected between the triode-section grid and pentode-section plate of V202 provides the regeneration. For faster rising trigger signals, the FAST RISE positions of the switch effectively removes the regeneration by shorting out plate-load resistor R220 in the pentode section of V202. V202 thus becomes a cathode-coupled amplifier.

Trigger output voltage is taken from the plate of the triode section of V202. The plate load is inductor-resistor differentiating circuit, L221, R221, so that a reasonably fast transition is required to develop large enough triggers to operate the sweep circuit. The multivibrator performs this fast transition for triggering waves otherwise too flat. It will perform a

regenerative transition in either direction for the slowest risetime signals.

The sharp trigger signal is capacitance coupled into V203, a cathode-coupled stage whose output is direct coupled through cathode follower V204A to the junction of the plate of V211A and the cathode of V211B of the cascode Eccles-Jordan multivibrator. A positive signal on the B section grid of V203 is required to trigger the multivibrator. The B section of V203 is also connected to a bias-control potentiometer called STABILITY which sets the dc level.

V204B, and V205 A and B surrounding V204A comprise a hold-off circuit. The function of the hold-off circuit is to reduce the voltage on the grid of the triggering cathode follower, V204A, during the sweep and for a short period after the multivibrator has recovered. V205B performs this function. During the sweep, V205B conducts so that its plate drops. At the termination of the sweep, V205B is cut off and its plate rises toward 225 volts positive. A switched capacitor between plate and ground delays this rise toward +225 volts during the charge period, depending on the size of the capacitor. When the plate of V205B reaches 100 volts positive it is clamped to this voltage by diode-connected V205A. The trigger amplifier is so designed that it will trigger the multivibrator only when its plate is in the vicinity of 100 volts, so that triggering is held off during the rise period of the plate of V205B.

V211 and V212 comprise the cascode Eccles-Jordan multivibrator. The left-hand side of this multivibrator, V211 A and B are normally conducting. Triggering is accomplished with a positive trigger through V203 to cathode follower V204A causes it to divert current from the upper half of V211, so that the plate rises. The positive step at V211B plate is coupled through cathode follower V210B to the grid of the opposite lower side of the multivibrator, V212B, and the multivibrator flops over with conduction on the right-hand side. Cathode follower V210B acts as a buffer between the plate of V211B and all other external loads so that the only additional capacitance is that added by the input capacitance of the cathode follower. This permits the plate to execute a much more rapid rise. The cathode follower drives the opposite side of the multivibrator, the unblanking cathode follower, the hold-off tube, V205B, and the gate output cathode follower, V214A.

The sweep is gated by the negative-going portion of the multivibrator, V212A and B. The plate of V212A is connected to the grid of the cathode-follower-connected pentode section of V214 through a speed-up capacitor. The cathode of this cathode follower holds

the grid of V220 at about -3 volts through diode V215 during the quiescent state of the multivibrator. The negative step from the multivibrator cuts off the cathode follower and the cathode falls, disconnecting the grid of V220 through diode V215. V220 is the Miller tube time base generator. When the grid is freed from V214B cathode, it immediately begins to drop and the plate begins to rise. The plate of V220 is coupled back to the grid through cathode follower V212A and the timing capacitor, and a Miller run up commences. When the plate has risen to the vicinity of 200 volts, the grid of cathode follower V213B has risen to about 100 volts so that current begins to flow in this tube which diverts current from the upper right section of the multivibrator, V212A, and the multivibrator reverts to the initial stage with the left-hand side conducting. When V212A plate rises, it carries the grid of V214B with it causing diode V215B to conduct and the Miller grid to rise to -3 volts so that the plate drops again to the starting position.

The additional circuitry around the Miller tube and direct-coupled Eccles-Jordan multivibrator is provided to raise the maximum sweep speed and to eliminate the usual distortion of the sawtooth at the beginning of the Miller run-up action.

Since the multivibrator has no timing-circuit components, its recovery time of about 1 microsecond is dependent largely on tube and wiring capacitance, and is therefore more or less constant over the entire range of time bases. For the longer time bases, as much as a millisecond is required to discharge the timing capacitor, so that circuitry is needed to prevent the multivibrator from being triggered before the Miller tube has returned to its quiescent state. The required hold-off function is produced by lowering the plate return voltage of the trigger amplifier V203A for an adequate period after the time base termination. Furthermore, a sharp differentiated pulse must be derived from a triggering waveform to trigger the multivibrator so as to prevent the multivibrator from re-triggering after the hold-off circuit has reached quiescence, in the presence of a sustained triggering waveform.

The circuit complication around the Miller tube removes the step from the start of the Miller run up. This is accomplished by means of a dc feedback network from the plate of the Miller tube back to its grid, which causes an equilibrium point to be established where the plate of the Miller tube is resting at about 50 volts positive whenever the grid of the gating cathode follower, V214B, is held in a positive direction by the right-hand multivibrator, and the grid is at -3 volts. This is well within the class A region of the

Miller tube, V220, where the plate voltage is directly proportional to the grid voltage. The relationship of 50 volts plate to -3 volts grid voltage is therefore determined by the grid to plate relationship of the Miller tube itself in the class A region of its operation. The actual grid voltage set by the voltage-divider cathode follower arrangement with V214B through disconnecting diode V215B and constant-current tube V213A, determines the starting voltage of the sawtooth. When diode V215 B disconnects the Miller tube grid from the divider constant-current tube V213A attempts to sustain the current, which it does by reducing its plate resistance, thereby pulling the Miller tube grid downward. During the period of the run up, the timing-capacitor charging current is kept essentially constant by action of the constant-current tube. The charging current remains constant within about a tenth of a per cent, but the time base is not this linear because of the variation of capacitance with voltage of the timing capacitors.

The sawtooth voltage is fed to the output amplifier through cathode follower V221A by means of a voltage divider so that horizontal positioning can be accomplished. Cathode follower V221B prevents grid current from flowing in the positioning circuit, and cathode follower V222A prevents grid current from flowing in the MAG-NORM feedback network. This network reduces the net gain of the horizontal amplifier by a factor of five in the NORM position, and permits the full gain to be realized when it is in the MAG position.

The horizontal-output amplifier stage is a cathode-coupled phase inverter with a cathode-follower coupler to each deflection plate. Use of the cathode followers to drive the deflection plates increases the horizontal bandwidth by a factor of about three times.

MAGNIFIER

A degenerative network between the plate of V224B of the output amplifier to the grid of cathode follower V222A reduces the loop gain by a factor of five in the NORM position of the MAG-NORM switch. In the MAG position, the network is opened to permit the amplifier to operate at full gain. The MAG POSITION screwdriver control permits the dc level of the cathode follower to be set at the same value for both positions. Another screwdriver adjustment labeled MAG GAIN ADJ on the chassis permits the magnified time base to be made exactly five times the normal time base. The HORIZ POSITION control precedes the magnifier circuits and therefore positions for both the magnified and the normal time bases.

VERTICAL AMPLIFIER

V1 is a twin-triode with the two sections operated in parallel. The signal is taken from the common cathode connection of V1 and applied to the cathode of V2A. V2A is operated as a grounded-grid amplifier. V2B is a cathode-follower output coupler between V2A plate and V3 grid. The preamplifier is used only on the AC, .01 VOLTS/DIVISION position of the AMPLITUDE selector switch. In this switch position, switch section SW1B connects the input terminal through C1 to the grid of V1A and B, and SW1C connects the cathode of cathode-follower V2B to the grid of V3 through a protective network. R15 is a screwdriver adjustable resistor to permit the preamplifier gain to be adjusted accurately to ten times. L1 and L2 are series peaking coils to improve high-frequency response.

V3 and V4 form a cathode-coupled gain-control stage. The signal is applied to the grid of V3 and coupled through the common unbypassed cathode connection to V4 which operates as a grounded-grid amplifier. The MULTIPLIER switch, SW2, connects any one of three resistor networks or a short circuit between the two cathodes to control the stage gain. In the X1 position, the cathodes are connected together and the gain is at a maximum. In the 10-1 position, an adjustable resistor is connected between cathodes to permit continuous adjustment of gain. R51 and R53 connected into the circuit in the other two positions of the switch are screwdriver adjustable to permit the gain to be adjusted to one-half or to one-fifth accurately so as to accommodate the gain to the calibrations of the graticule. R34 is a protective resistor which limits the positive excursion of V3 grid in case a high dc voltage is connected to the input connector in the dc position of SW1. C14 bypasses R34 at higher frequencies.

Plate output from V4 feeds through the delay network to the grid of V8B, a cathode-follower output-coupling tube. R59 terminates the delay network through C21 to ground. (C21 is physically located on a bracket underneath the delay-network assembly.) The delay network delays the vertical-deflection signal long enough to permit the portion of the waveform that has triggered the sweep to be displayed on the crt screen.

The output amplifier consists of V10 and V11 in parallel, in a cathode-coupled grounded-grid phase-inversion circuit with V12 and V13 in parallel. The dc grid voltage of V12 and V13 is used for vertical positioning. This voltage is controlled by V8A, a cathode-follower voltage regulator whose grid voltage is obtained from potentiometer R70, labeled

VERT POSITION, connected between ground and +100 volts. R65 and R66 limit the positioning range.

R90, a part of the coupling between cathodes of V10, V11 and V12, V13, is a screwdriver adjustable resistor whose shaft is mounted coaxially with the AMPLITUDE control knob. This adjustment permits the gain of the amplifier to be accommodated to the calibrations of the graticule.

L3 in the grid circuit and L4, L5, L6, and L7 in the plate circuit provide frequency compensation.

An internal triggering signal connection from the plate of V3 to the trigger-selector circuits permits the sweep circuit to be triggered by the observed signal.

In all other positions of the AMPLITUDE control SW1, than the previously-described AC, .01 VOLTS/DIVISION position, the preamplifier is removed from the circuit, and the INPUT connector is connected to the grid of V3, either through attenuators, or unattenuated. In the AC portion of the control, C1 is connected in series with the INPUT connector. The grid of V4 is grounded in these positions through switch section SW1D, and V3 and V4 become a cathode-coupled grounded-grid amplifier.

The compensated input attenuators to the grid of V3 are voltage dividers in which parallel capacitor and resistor voltage dividers have the same division ratio. C3 in the 10-to-1 divider and C6 in the 100-to-1 divider permit adjustment to be made of the capacitive voltage division so that the high-frequency division ratio is the same as the low-frequency division ratio.

C2, C5, and C10 are adjustable so that the same input capacitance will exist at all AMPLITUDE switch positions. This is necessary when the probe is used because the probe is compensated for the input capacitance, and would otherwise need to be re-adjusted for each switch setting. C15 connected between grid of V3 and screen of V4 is a neutralizing capacitor that reduces the change in input capacitance that occurs when the MULTIPLIER switch inserts the various coupling resistors between cathodes of V3 and V4.

The MULTIPLIER switch, SW2, selects the amount of coupling between cathodes of V3 and V4 to determine the gain of the amplifier when the preamplifier is switched out. The VERT ATTEN ADJ is a chassis-mounted screwdriver adjustable potentiometer connecting the cathodes of V3 and V4 to -150 volts. This control operates differentially. When it increases the resistance to the cathode of V3 it simultaneously decreases the resistance to the cathode of V4. When it is properly adjusted, the dc voltage at the two cathodes is the same and no change in vertical

positioning occurs when the multiplier switch connects larger of smaller resistors between them.

CALIBRATOR

The calibrator provides four squarewave voltages of 100 volts, 10 volts, 1 volt and 0.1 volt, available at a UHF coaxial fitting on the front panel but not connected internally to the vertical amplifier. The source of squarewave voltage is a self-excited symmetrical ac-coupled multivibrator operating at a repetition frequency of about one kilocycle. The cathode and grids of this multivibrator are returned to -150 volts.

During the conducting period of V601B, the grid of V601A is below -150 volts and the A-section plate is cut off. V602B grid is directly connected to V601A grid and V602B plate is therefore also cut off during this period.

During the conducting period of the A section of V601, grids of V601A and V602B are both high and the plate of V602B is down below ground potential. The grid of cathode-follower V602A is directly connected to V602B plate, and it therefore varies between cutoff in the negative direction and a point near 100 volts in the positive direction, determined by voltage divider R610, R611, R612.

The cathode resistor of cathode-follower V602A is made up of a voltage-divider string, R620, R621, R622, R623, which are of such values that voltages of 10 volts, 1 volt and 0.1 volt, peak to peak, are produced at the taps when the cathode voltage is set at 100 volts, peak to peak.

R612, a screwdriver adjustment labeled CAL ADJ on the chassis, permits the grid of V602A to be set at such a level that the cathode will be at 100 volts when V602B is cut off. Since this portion of the circuit remains connected to the $+225$ -volt supply when the CALIBRATOR switch is turned to the OFF position, the voltage calibration of the calibrator circuit can be checked with a dc voltmeter.

C603 in the grid circuit and C604 in the cathode circuit of the cathode follower reduce a small transient waveform distortion.

POWER SUPPLY

The power-supply transformer, T401, is capable of operating satisfactorily over the range of frequencies between 50 cps and 800 cps. The primary of this transformer is wound in two 117-volt sections, normally

paralleled for 117-volt operation, but they are arranged to be easily reconnected in series for 234-volt operation.

Four selenium full-wave bridge rectifiers, each supplied with ac from a separate section of the transformer secondary, provide dc to four electronic voltage regulators from which are obtained the regulated voltages of -150 volts, $+100$ volts, $+225$ volts and $+350$ volts. In addition to these four regulated voltages, two unregulated voltage sources are provided, one at a nominal $+330$ volts from a tap taken ahead of the $+225$ -volt regulator, the other at a nominal $+420$ volts taken from a tap ahead of the $+350$ -volt regulator.

The regulator will regulate satisfactorily over a primary input-voltage range between 105 and 125 volts, or between 210 volts and 250 volts.

Five 6.3-volt secondary windings furnish heater power for the various parts of the instrument, and for the pilot light and graticule illumination.

Forced-air cooling is provided by a blower fan. Two fan types are available. If the Type 315D oscilloscope is to be used only on 50- to 60-cycle supply voltage, a 60-cycle fan is recommended, and is ordinarily supplied with the instrument. If higher frequencies of input voltage are to be used, however, a dc fan and rectifier are available at extra cost which will operate over the same range of frequencies that the transformer will.

Negative 150-Volt Regulator

The basic source of reference voltage is a type 5651 voltage-regulator gas diode, V401, in the cathode circuit of V402, a voltage-comparator tube. Voltage-divider string, R409, R410, R411, connected between regulated -150 volts and ground, is tapped at a voltage above -150 volts approximately equal to the voltage across the reference tube, V401, and connected to the grid of V402. This sets the cathode and grid of V402 at approximately the same voltage, and any change in voltage at the -150 -volt bus becomes a change in grid-to-cathode voltage at V402. This change is amplified in V402 and applied directly to the grids of V403 and V404, two series-regulator tubes connected together in parallel in the ground lead of the power supply. If the -150 -volt bus tends to go negative below this voltage, for example, the cathode of V402 will drop thereby increasing V402 plate current. Increased plate current will lower V402 plate, which will pull down the grids of V403 and V404, thereby increasing their plate resistance, so that they insert a higher drop in the ground lead, and the -150 -volt bus will rise in the direction to correct the original

negative tendency. C404, bypassing R407, R409, and part of R410, improves the ac gain of the comparator circuit and reduces ripple. R410 is adjustable by a screwdriver adjustment labeled 150 V ADJ on the chassis, so that this voltage can be set accurately.

+100-Volt Regulator

The +100-volt supply is regulated by comparing to ground in comparator-tube V421, a voltage near ground on voltage-divider R424, R425, connected between -150 volts and the regulated +100-volt bus. The difference voltage is amplified in V421 and applied to the grid of series-regulator tube, V422, connected in series with the positive lead. C421 improves the ac gain and reduces ripple. C420 filters the unregulated dc input to the regulator, and C422A, one of three capacitors in one can, filters the regulated portion.

+225-Volt Regulator

The +225-volt supply is regulated by comparing to ground potential in comparator tube V441, the voltage near ground potential on voltage divider R444, R445, connected between -150 volts and the regulated +225-volt bus. The difference voltage is amplified in V441 and applied to the grid of series-regulator tube V442A, connected in series with the +225-volts bus. Dc input to this regulator is supplied from a second rectified and filtered but unregulated source connected in series with the previous source. C440 filters the unregulated input to the regulator. A tap ahead of the regulator provides a nominal +330 volts, unregulated. C442B, the second of three capacitors in one can, filters the regulated supply at +225 volts. R443, bypassing the series-regulator tube, increases the available current at the regulated bus. C441 increases the regulator ac gain to reduce ripple.

+350-Volt Regulator

The +350-volt supply is regulated by comparing to ground potential the voltage near ground potential on voltage-divider R467, R468, connected between -150 volts and the regulated +350-volt bus, in comparator tube V461. The difference voltage is amplified in V461 and applied to series-regulator tube V442B in series with the +350-volt bus. Dc input to this regulator is supplied from a third rectified and filtered, but unregulated source connected in series with the previous two sources. C460, in series with C440 of the previous supply, filters the unregulated input to the regulator. A tap is taken off ahead of the regulator at a nominal +420 volts, unregulated. C422C, the third of three capacitors in one can, filters the regulated +350-volt bus. R465, bypassing the series-regulator tube increases the current available

at the regulated bus. C461 increases the regulator ac gain to reduce ripple.

R412, a front-panel control labeled SCALE ILLUM, is a variable resistor in series with the graticule illuminating lights which permits the brightness of the graticule illumination to be varied.

HIGH-VOLTAGE AND CATHODE-RAY TUBE CIRCUITS

Accelerating voltage of about -1500 volts is applied to the cathode of the cathode-ray tube. This high voltage is obtained by rectifying a 50- to 60-kilocycle high-voltage alternating current supplied by an oxide-core transformer whose primary forms the inductor of an inductance-capacitance oscillator. The primary inductance is center tapped so that it can be used in a Hartley oscillator. C804 is the tank capacitor and V803 is the oscillator tube. Plate power is fed by way of the center tap on the inductor at a nominal +350 volts from the unregulated side of the regulated +225-volt supply. V804 in the negative lead of the high-voltage winding is the rectifier supplying dc to the crt cathode. The rectifier filaments are supplied from additional windings on the same transformer. The positive end of the transformer winding is connected to regulated +225 volts. Filtering is provided by C815 connected to ground from V804 plate, and by C816 and C817 in series, also between V804 and ground.

A voltage-divider string of resistors, R902, R903, R904, R817, and R816 connected between the rectifier plate and regulated +350 volts provides voltage taps for the focusing grid and for a sample of the high voltage for use in the high-voltage regulator system. R903 of the resistor string is a front-panel control potentiometer labeled FOCUS which permits the voltage of the focusing grid to be adjusted for best focus.

R817 in the resistor string is a screwdriver-adjustable potentiometer, the arm of which is at about -150 volts. The voltage from the arm is compared to -150 volts in comparator tube V801A. The plate of V801A is connected to +350 volts through a very high resistance load, R802, and sits near ground potential. The grid of V801B is connected directly to the plate of V801A, and the plate of V801B is connected directly to the screen of oscillator-tube V803 and through plate-load resistor R803, to regulated +225 volts. Any departure of the voltage tap on R817 of the high-voltage resistor string is therefore first amplified in comparator tube V801A and again in V801B so as to change the screen voltage of V803. For example, if the oscillator voltage becomes too high, the grid voltage of V801A will drop, its plate

will rise carrying V801B grid up with it. Plate current in V801B will increase, its plate will drop carrying the screen of oscillator V803 down with it, thereby reducing the gain of this tube so that the oscillation amplitude will drop.

UNBLANKING

A second high-voltage winding and rectifier supply the control grid of the cathode-ray tube at about -1600 volts. V805 is the rectifier and C818 is the filter capacitor. R910, in a voltage-divider resistor string across the high voltage is adjustable by means of a front-panel control labeled INTENSITY to permit adjustment of the spot intensity.

The positive end of this supply is connected to the unblanking-output tube, V210A, through R914. Thus the whole control-grid voltage supply including the transformer winding is raised and lowered in voltage

by the unblanking pulse. This arrangement provides dc coupling of the unblanking waveform to the control grid, thereby making it possible to use as slow a sweep as desired. R914 and C902 improve the rise-time of the pulse appearing at the control grid.

The astigmatism control, labeled ASTIG on the front panel is a potentiometer, R920, connected between regulated +225 volts and regulated +100 volts.

An external cathode connection is provided via C901 for introducing external z-axis signals to provide beam-intensity modulation if desired. R905 prevents dc, which might leak through the dielectric of C901, from developing high voltage at the connector.

Components shown on the right of the broken line in the diagram are located on a horizontal bakelite mounting board above the end of the cathode-ray tube. The transformer, rectifier tubes, and filter capacitors shown on the diagram to the left of the broken line, are mounted inside a shield at the left lower rear corner to the left of the power transformer.

SECTION IV

Maintenance and Adjustment

FILTER MAINTENANCE

Care must be taken to assure free ventilation of the instrument inasmuch as some of the components are operated at dissipation levels such that excessive temperatures will result without adequate air circulation.

Washable Lumaloy Air Filters are used at the air intake ports of the instrument. The following filter cleaning instructions are given by the filter manufacturer.

"To Clean:

- (1) If grease or dirt load is light, remove filter from installation and flush dirt or grease out of filter with a stream of hot water or steam.
- (2) If load is too heavy for treatment in (1) above, prepare mild soap or detergent solution (see paragraph below on use of caustics) in pan or sink deep enough to cover filter when laid flat. Agitate filter up and down in this solution until grease or dirt is loosened and carried off filter.
- (3) Rinse filter and let dry.
- (4) Dip or spray filter with fresh Filter Coat, or other approved adhesive. Filter Coat is available from the local representative of RESEARCH PRODUCTS CORP. in the one-pint Handi-Koter with spray attachment or one-gallon and five-gallon containers.

In most cases hot water, steam, or hot water and mild soap solution (Ivory, Dreft, Vel, etc.) is all that is needed to restore the dirt or grease laden filter to its original sparkling lustre. However, where extreme conditions are encountered with higher-than-average dirt or grease loads or where maintenance of the filters has been neglected, allowing an accumulation of hard grease or caked dirt, more comprehensive cleaning steps may be taken.

CAUTION: IN CASES OF THIS KIND, USE OF CAUSTICS WITHOUT RECOMMENDED INHIBITORS ADDED IS DAMAGING TO THE FILTER.

(For information on correct procedure, write the Research Products Corporation stating name of

cleaning agent and concentration.) Certain nationally known and nationally distributed cleaners are approved for use in dish-washers, cleaning tanks or filter service company equipment. Following is a partial alphabetical list of cleaners already tested and approved by Research Products Corporation:

CLEANER	MAKER
Calgonite	Calgon, Inc.
K O L	DuBois Company
Oakite Composition No. 63	Oakite Products, Inc.
Pan Dandy	Economics Lab., Inc.
Super Soilax	Economics Lab., Inc.
Wyandotte Keego	Wyandotte Chem. Corp.

Non-inclusion of any other cleaners is not intended to indicate their being unacceptable. For specific information on other products, write the Research Products Corporation, Madison 10, Wisconsin."

REPLACEMENT OF COMPONENTS

Most of the components used in the construction of TEKTRONIX instruments are standard parts obtainable from any well-equipped parts distributor. Some of the components carrying 1% and 2% tolerances may not be so readily obtainable but may be purchased from the manufacturer at these tolerances. The remainder of the low-tolerance components are standard 10%- and 20%-tolerance parts that are checked at the factory for proper value or performance. Replacement parts are available on order from the factory at current net prices but in the case of standard parts it is probably more economical of time to purchase them locally. It is not feasible to attempt to check out low-tolerance parts or matched pairs without a reasonably large stock to choose from as the rejection percentage is quite high in many cases.

IMPORTANT: It is imperative that you get parts-ordering information from the instruction book prepared specifically for the instrument involved. The serial number of the instruction book must agree with the serial number of the instrument.

A TEKTRONIX instruction manual will usually contain hand-made changes of diagrams, parts lists, and text, appropriate only to the instrument it was prepared for. There are good reasons why this is true.

First, TEKTRONIX engineers are continually working to improve TEKTRONIX instruments. When the improved circuitry is developed or when better components become available, they are put into

TEKTRONIX instruments as soon as possible. As a result of constant improvement TEKTRONIX instruments are always built as good as we can build them, but the changes caused by these improvements must frequently be entered by hand into the manual.

Second, when TEKTRONIX instruments go through our exhaustive test procedure, TEKTRONIX technicians adjust them individually to obtain optimum operation. This kind of hand tailoring occasionally requires substitution of components differing from the nominal values printed in the manuals.

Third, because of procurement difficulties, equivalent but different parts are sometimes used. Usually such parts are directly interchangeable with those originally specified. No alternate parts have been used which adversely affected the instrument, and you were able to receive your instrument much earlier than you might have otherwise.

To assure that you will receive the correct replacement parts with the minimum of delay it is therefore important that you include the instrument serial number with your order, along with the instrument type and part numbers, of course. And as a further precaution, get ordering information from the instruction manual whose serial number agrees with the instrument.

Equivalent parts, supplied by the factory when the exact replacement parts ordered are not available, will be accompanied by an explanation and will be directly interchangeable in most cases.

CAUTION: Use only silver-bearing solder on the ceramic terminal strips and for tinning the soldering iron, if it becomes necessary to resolder.

The slots in the ceramic terminals are filled with solder containing 3 per cent of silver which is bonded to a film of pure silver fused with the porcelain glaze. Ordinary tin-lead solder absorbs the silver from the fused film to the extent that a bond can no longer be formed between the solder and the porcelain after only a few resoldering operations.

Silver-bearing solder is used in printed- and etched-circuit techniques and is therefore readily available from all principal solder manufacturers. A length of three-per cent silver solder included with the instrument will be found mounted on the left side of the chassis.

REMOVAL OF THE CASE

Set the oscilloscope face downward on a padded flat surface, turn the two fasteners on the back ap-

proximately $\frac{1}{4}$ turn to the left, and lift off the case. The power cord is not removable so it must be fed through the hole as the cabinet is removed.

CAUTION: Voltages high enough to be dangerous are present in this instrument. Since much maintenance must necessarily be performed with the case removed, great care should be taken to avoid contact with bare leads. Use only insulated tools, stand on a dry floor, and if possible, keep one hand in your pocket.

POWER SUPPLY

Line Voltage

The power supply of the Type 315D Oscilloscope will operate satisfactorily over the voltage ranges 105 to 125 volts and 210 to 250 volts.

The power transformer is wound with two 117-volt primaries. When the instrument leaves the factory, the primaries are ordinarily connected in parallel for 117-volt operation. If operation from 234-volt lines is desired, remove the jumpers on the power transformer between terminal 1 and terminal 2, and between terminal 3 and terminal 4. Now connect terminals 2 and 3 together. With the line still connected to terminals 1 and 4, the instrument is ready for 234-volt operation.

The fuse normally supplied when the Type 315D is wired for 117-volt operation is 5-amp, 250-volt "Slo Blo". For proper protection on 234-volt operation, this fuse should be changed to 2½-amp, 250-volt "Slo Blo".

Line Frequency

The Type 315D is supplied in two different models, for universal line frequency 50 to 800 cycles, or for 50- to 60-cycle operation. The only difference between these models is in the fan motor supplied. The universal 50-800-cycle model uses a dc series-wound motor with a full-wave selenium bridge rectifier. A 37½-volt winding on the power transformer supplies the power to the rectifier. (NOTE: A few of the early instruments did not have this winding but rather used a half-wave rectifier and a series resistor connected directly to the 117-volt line.)

Change of Fan Motor

The 60-cycle model uses a standard 60-cycle shaded-pole 117-volt motor. This motor, having no brushes, will run quieter and the life should be longer than the dc model. This motor is recommended where the universal feature is not needed. The mounting plates are identical on the two motors so it is possible to

change from one to the other if the need should arise. If wired for the 60-cycle motor, the motor wires (grey) should go to terminals 1 and 3. If wired for universal line frequency, the wires should go to terminals 14 and 17. A name plate on the back of the instrument indicates the line frequency. This plate should be changed if the motor is changed.

Dc Voltages

All dc voltages are regulated and are referred to the -150-volt supply. In order for the instrument to perform properly, it is necessary for the minus 150-volt supply to be within plus or minus 2% of this value. The voltage should be checked with an accurate voltmeter and corrected if necessary by adjusting potentiometer R410 marked ADJUST -150V (screwdriver adjust), located on the center bulkhead. This check should always be made if the 5651 tube V401 is changed.

High Voltage

The calibration of the TIME BASE and VERTICAL AMPLITUDE controls are dependent on the acceleration voltage applied to the cathode-ray tube. If it is suspected that the calibrations are off, the high-voltage supply should be checked with an accurate meter of at least 20,000 ohms-per-volt sensitivity. The supply voltage should be adjusted to -1800 volts from the cathode (pin 3) of the CRT to ground by means of the potentiometer R817 marked H.V. ADJUST. If more convenient, this reading may be made from the plate of V804 (heavy green lead) to ground. V804 is the lower rectifier tube located under the shield.

CALIBRATOR

Before adjustments are made on the vertical amplifier, it is well to check the output adjustment of the calibrator. Inasmuch as the clipper, cathode-follower V602A, remains conducting even with the CALIBRATOR switch in the OFF position, it is possible to adjust the voltage accurately with a dc voltmeter.

An accurate voltmeter of at least 1000 ohms-per-volt sensitivity should be connected to the cathode (pin 3) of V602A. (This is the yellow lead going to the back of the CALIBRATOR switch.) The switch should be turned to the OFF position and R612 (screwdriver potentiometer marked CAL ADJ on the main bulkhead) adjusted to a reading of +100 volts. The calibration voltage will then be accurate on all settings.

VERTICAL AMPLIFIER

NOTE: A warm-up period of approximately 15 minutes to stabilize the characteristic should precede adjustments of the vertical

amplifier. Also best results will be obtained if the adjustments are made in the following order:

Amplifier Gain Adjustment

Set the AMPLITUDE selector switch to the dc position, .1 VOLT/DIV. Set the MULTIPLIER to 1; set the CALIBRATOR to 1. Connect a lead between CAL OUTPUT and INPUT, with the STABILITY control advanced so the time base is free running. Adjust the VERT POSITION control until the bottom of the display coincides with the lowest small mark on the graticule. Then adjust R90 (screwdriver adjustment in center of AMPLITUDE knob) until the top of the display coincides with the top small mark on the graticule (10 division). The CALIBRATOR voltage should be set to .1 and the display should occupy one scale division at any setting of the VERT POSITION control.

2X MULTIPLIER Adjustment

The CALIBRATOR should again be set to 1 volt and the MULTIPLIER set to 2. R51 (located on the outside of the bracket supporting the MULTIPLIER switch) is adjusted to give a display of 5 divisions.

5X MULTIPLIER Adjustment

Next set the MULTIPLIER switch to 5, adjust R53 (located on the inside of the bracket) to give a display of 2 divisions. With the MULTIPLIER switch in the 10-1 (red) position, a full rotation of the center (red) knob will now give a display of 10 divisions in the full-clockwise position and approximately 1 division in the counter-clockwise position.

Attenuator Adjustment

Now turn the CALIBRATOR to OFF and position the trace to the center of the screen. As the red knob (10-1) on the MULTIPLIER is rotated, there should be no change in position. If there is a change in position, R55, VERT ATTEN ADJ (located on side of vertical amplifier chassis) should be adjusted until there is no change in position as the red knob is rotated.

NOTE: This adjustment as well as the PRE AMP GAIN ADJ may require an occasional touching up as the tubes age. Therefore holes have been provided in the sides of the cabinet to allow access to these controls.

PREAMP GAIN Adjustment

Set the CALIBRATOR to .1 volt, set the AMPLITUDE to .01 VOLTS/DIVISION, MULTIPLIER to 2. Adjust R15, labeled PRE AMP GAIN ADJ, located on side of vertical amplifier chassis, to give a display of 5 scale divisions.

Input Attenuator and Probe

The various input attenuators in the Type 315D are of the resistor-capacitor type. The resistor divider ratio is equal to the capacitor divider ratio, and therefore the voltage division is constant for any frequency from dc to well above the requirements of the instrument. Adjustments of these attenuators is readily made while observing their square-wave response. The self-contained calibrator in the Type 315D is a suitable square-wave source, and thus a check of the attenuators is always available. When the variable capacitors in the attenuators are properly adjusted, a square wave will be correctly reproduced by the oscilloscope. If the capacitive divider has a lower attenuation than the resistive divider, a spike will appear on the leading edge of the square wave. If the capacitive divider has a higher attenuation, the corner of the leading edge will be rounded. The following adjustment procedure is recommended:

Shield

1. Lay a sheet of metal on the top of the instrument to simulate the presence of the case.

C3 Adjust

2. Set the CALIBRATOR to 10 volts. Set the AMPLITUDE to AC, 1 VOLT/DIV and the MULTIPLIER to 2. With the TRIGGER SELECTOR set to +INT, SLOW RISE, adjust the TIME BASE to display 8 to 10 cycles of the CAL waveform across the screen. Adjust C3, the rear trimmer, on the side of the switch.

C15 Adjust

3. Turn the MULTIPLIER to the 10-1 position (red), set the center knob full counter-clockwise, and set the CALIBRATOR to 100 volts. Adjust C15, located on the chassis just in the rear of the MULTIPLIER switch, until no overshoot is observed. (NOTE: It may be necessary to repeat step 2 after this adjustment as there is some interaction.)

C6 Adjust

4. Set the AMPLITUDE to AC, 10 VOLTS/DIV, set the MULTIPLIER to 2, set the CALIBRATOR to 100. Adjust C6 (located on the rear of the switch, and adjusted through the hole in the chassis.)

Probe Adjust (C101)

5. Remove the wire connecting CAL OUT and INPUT, and connect the probe, place the tip of the probe in CAL OUT. Set AMPLITUDE to .1 VOLT/DIV, MULTIPLIER on 2, and set the CALIBRATOR on 10. Adjust C101, located on the probe body.

C2 Adjust

6. Set AMPLITUDE to 1 VOLT/DIV, MULTIPLIER on 2. Set CALIBRATOR to 100 volts. Adjust C2, located on the side of AMPLITUDE switch.

C5 Adjust

7. Set AMPLITUDE to 10 VOLTS/DIV, MULTIPLIER on 1, with the CALIBRATOR at 100 volts. Adjust C5, located on the front of the AMPLITUDE switch, through the hole on the chassis.

C10 Adjust

8. Set the AMPLITUDE to .01 VOLTS/DIV, MULTIPLIER on 2, with the CALIBRATOR on 1 volt. Adjust C10, located near V1 on the front of the vertical amplifier chassis.

HIGH-FREQUENCY COMPENSATION

The following describes the adjustment procedure for high-frequency compensation in the Type 315D. The adjustments are not extremely critical. However, they do require considerable care to obtain optimum results. Also since once adjusted, they are fairly stable, readjustment should not be attempted without first eliminating other possible sources of waveform distortion, including defective tubes or a deficient signal source. A suitable square-wave generator or pulser is necessary in making any high-frequency adjustments of the Type 315D. The square-wave generator rise time must not exceed .04 microseconds. A TEKTRONIX Type 104A or Type 105 Square-wave Generator will provide a suitable signal. All connections between the generator and the oscilloscope should be coaxial type and MUST be properly terminated, preferably at both ends of the cable.

Disconnect Delay Network

1. In the Type 315D, the DELAY NETWORK must be disconnected before any adjustments are made on the vertical amplifier. This can be done as follows:

Disconnect the red lead (delay line input) from pin 6 (plate) of V4.

Disconnect the purple lead (delay line output) from pin 7 (grid) of V8B.

Connect a jumper from pin 6 of V4 to pin 7 of V8B. This lead should be no longer than necessary and should be kept well away from the chassis.

Connect a 1000-ohm, 1-watt, resistor from pin 7 of V8B to the +100-volt bus. The +100-volt bus is located on the terminal of C21, which is on the bracket below the delay network.

Amplitude of Test Signal

2. Apply a square wave of 750 kc to 1 mc to the input of the Type 315 oscilloscope. Adjust the amplitude of the square wave so that it causes a deflection of 5 to 6 divisions with the AMPLITUDE set on .1 VOLTS/DIV and the MULTIPLIER on 1 or 2.

3. Adjust the TIME BASE to display 3 or 4 cycles of the square wave.

Compensating Coil Adjustments

4. Observe the leading edge of the square wave. Adjust L3, L4, L5, L6, and L7, if necessary, for the best waveform with the least overshoot on the leading edge of the wave. All of these adjustments interact to some extent so only a small adjustment should be made to any one coil at a time. NOTE: If the above steps are properly made, the waveform should look very good at this point. However, there may be a few remaining small wrinkles. This should not cause concern as they will disappear when the delay line is re-installed.

Preamp. Adjust

5. Insert a 10-to-1 pad in the signal lead from the generator, or reduce its output sufficiently that it will not overload the preamplifier. Set the AMPLITUDE to .01 VOLT/DIV, adjust L1 and L2 for best waveform. NOTE: These adjustments are not very critical and it may require a large change in inductance to show any change in waveform. The two coils should be adjusted so that the slugs are both in about the same position.

6. The delay network should be reconnected.

DELAY NETWORK

The delay network is a 19-section, M-derived, artificial transmission line providing a signal delay of .25 microsecond. An accurate impedance match between sections must be maintained to prevent reflections. Each section is adjusted by means of a variable capacitor (C501 to C522). The effects of these adjustments are distributed over the first .5 microsecond of the signal.

CAUTION: Adjustment of the delay network should not be attempted without first verifying normal transient response of the output amplifier as explained under "HIGH-FREQUENCY COMPENSATION". Otherwise the delay network adjustments may be set to compensate for deficiencies in the output stage. This will cause a loss in overall bandwidth of the instrument. The follow-

ing methods of adjustment will give satisfactory results:

Delay Network Test Signal

1. Apply a 100-kc square wave to the input of the oscilloscope with the AMPLITUDE set on .1 VOLTS/DIV. Set the TIME BASE to 1 MICRO-SECOND/DIVISION.

2. Adjust the DELAY NETWORK trimmers (C501 to C522) for the smallest ripple or irregularity on the first .5 microsecond of the square wave. The position of the irregularity determines which capacitor needs to be adjusted. Try adjusting one of the center capacitors to see where it produces its effect.

Leading Edge

3. Change the TIME BASE to 5 or 10 MICRO-SECONDS/DIVISION and observe the squareness of the leading corner. If the corner (first .5 microsecond) is higher in amplitude than the remainder of the square wave, repeat step 2, but setting all the capacitors at a higher capacitance. If lower, repeat using lower capacitor settings. It may be found that only part of the corner will slope up or down. In this case, only part of the capacitors will need to be increased or decreased.

Delay Network Terminating Resistor

If a square corner cannot thus be obtained, an incorrect termination resistor, R59 is indicated. To check this termination, turn off the 315D and allow the tubes to cool. Then measure R59 between pin 7 of V8B and the +100-volt bus (located on terminal of capacitor C21) with an accurate bridge. If outside the range of 1100 ohms $\pm 1\%$, replace with a composition resistor selected to be within these limits. (R59 is located in the delay-network chassis, which must be removed to replace the resistor.)

ASTIGMATISM

For best focus of both horizontal and vertical lines, the final anode of the cathode-ray tube must be returned to a voltage approximately equal to the dc voltage on the deflection plates. A preliminary setting of the ASTIGMATISM control (R920), located on the back plate of the instrument, may be made by connecting a voltmeter between ground and the center arm of this control, and adjusting to +190 volts. Because of variations in individual cathode-ray tubes, the best setting may differ slightly from this value, so final adjustment should be made while a signal is being observed. The optimum setting will give equally good focus of both horizontal and vertical lines. This should be made while a sine wave or a square wave

is being observed. This setting should be made simultaneously with the front-panel FOCUS control because these controls interact to some extent.

TIME BASE

A complete procedure for the adjustment and calibration of the time base is outlined here. However, in normal servicing, only necessary adjustments should be made.

TIMING SERIES CAPACITORS

If it is ever necessary to replace one of the timing-series capacitors (C280A, C280B, C280C, C280D) it is suggested that all four capacitors be obtained from TEKTRONIX, INC., and be replaced as a group. When ordering replacement parts be sure to mention instrument type and serial number.

The timing series consists of one group of four capacitors arbitrarily chosen from the six possible series shown below.

Nominal Value	Series 7-K	Series 7-L	Series 7-M	Series 7-N	Series 7-P	Series 7-Q
1 μ f	.96	.97	.98	.99	1.0	1.01
.1 μ f	.097	.098	.099	.10	.101	.102
.01 μ f	.0097	.0098	.0099	.01	.0101	.0102
1000 μ f	970	980	990	1000	1010	1020

The values shown are minimum with a tolerance of -0 to +1%.

Multivibrator Stability

1. Set STABILITY control (red coaxial knob) full clockwise. Adjust MULTI STABILITY (R254, screwdriver potentiometer on side of sweep deck) about half way between the points where the sweep stops on the left of the screen and where it stops on the right of the screen. NOTE: It may not be possible to make it stop on both sides. If not, adjust it to where it stops on one side or the other, then back it off approximately $\frac{1}{4}$ turn.

Sweep Length

2. With the sweep free running at 1 MILLI-SEC/DIVISION adjust SWEEP LENGTH (R261, screwdriver adjustment on side of sweep deck) until the sweep just covers the ruled portion of the graticule (approximately $10\frac{1}{2}$ division).

Trigger Sensitivity

3. Set the TRIGGER SELECTOR to +LINE or -LINE. Set the time base RANGE to 10 MICRO-SECONDS/DIVISION. Set the TIME BASE MULTIPLIER to 1. Set the VERTICAL AMPLIFIER AMPLITUDE to .1 VOLT/DIVISION, MULTI-

PLIER on 1. Advance the STABILITY control (red knob) until a trace appears. Now turn the STABILITY control back (counter-clockwise) until the trace disappears, or drops suddenly in intensity. If the trace disappears, adjust the TRIGGER AMPLITUDE DISCRIMINATOR until a dim trace is displayed. The time base is now triggered by the ac line frequency. Connect the 10X probe cable to the INPUT and touch the probe to the cathode of V203 (pin 3 and 8). This lead appears at the terminal of the 18-k, 2-watt resistor (R232) located on the terminal board just back of the TRIGGER SELECTOR switch on the underside of the sweep chassis. Adjust TRIG SENS (R223, screwdriver control, located on side of the sweep chassis) until a series of oscillations are observed on the trace, then back off the control to the point where the oscillations just disappear.

V201 Balance

4. Set the TRIGGER AMPLITUDE DISCRIMINATOR to 0 (center), and set the STABILITY control full counterclockwise. Connect a dc voltmeter between ground and the grid of the pentode section of V202, pin 2, and rotate the TRIGGER SELECTOR switch from the +EXT to the -EXT positions. The voltages in the two switch positions should be nearly equal at 190 volts. If there is a difference of over five volts it indicates either that the phase-inverter tube, V201, is not balanced, or that the plate resistors for this tube are not equal. V201 should be exchanged if necessary for a tube which gives as nearly equal voltage as obtainable with the switch in the two positions, and the resistors, R208 and R209, should be checked.

Internal-Trigger DC Level

5. With the controls set as in step 4, rotate the TRIGGER SELECTOR switch from -INT to +INT, and if necessary, adjust R202 (a screwdriver adjustment on side of TRIGGER SELECTOR switch) until the average of the two voltages is the same as the average voltage measured in step 4.

A. Set the AMPLITUDE selector to one of the AC positions. Connect a wire between INPUT and CAL OUTPUT. Set the CALIBRATOR and the AMPLITUDE control so that a vertical deflection of approximately 0.2 division is displayed. Set TRIGGER SELECTOR to +INT or -INT, SLOW RISE. Set the STABILITY control just below the point where the sweep free runs. Set the TRIGGER AMPLITUDE DISCRIMINATOR to 0 (center). Adjust INT TRIG DC LEVEL (R202, screwdriver adjustment on side of TRIGGER SELECTOR switch) until the point of triggering occurs as close as possible to the zero setting of the TRIGGER

AMPLITUDE DISCRIMINATOR. This point should be checked on both +INT and -INT settings of the TRIGGER SELECTOR. When a proper adjustment is made, the point of triggering will be at about the same rotation from zero with either positive or negative settings.

NOTE: For the following step and for all time-base calibration adjustments, either a suitable time-mark generator or an accurately calibrated oscillator is required. A suitable instrument is the TEKTRONIX TYPE 180 TIME-MARK GENERATOR.

V213 Check (Constant-Current Tube)

6. Set the marker generator for one-microsecond marks. Set the TIME BASE to 1 MICROSEC/DIVISION, and the MULTIPLIER to 1. Display a stable trace of the time marks, and watch the trace as you short out R279 (15-ohm resistor in heater lead to V213A, located on bakelite board on back of sweep chassis). Keep R279 shorted for at least 30 seconds. If any change occurs in the time base replace the constant-current tube, V213. A tube should be selected for this position which shows no change as the heater voltage is changed. A tube with low emission or with high heater-to-cathode leakage is unsatisfactory in this position. High heater-to-cathode leakage in this tube will cause an error in the timing of the 5 SEC/DIVISION range. If this trouble is suspected, its presence can be checked by setting the RANGE switch to 1 SEC/DIVISION and MULTIPLIER to 5, and advance the STABILITY control to get a recurrent sweep. Time the full 10-centimeter transit time first with the line voltage near 105 volts and second with the line voltage increase to the vicinity of 125 volts. Any difference in the timing with a change in line voltage indicates cathode-to-heater leakage in the constant-current tube.

Time Base Calibration

7. Set the TIME BASE RANGE on 1 MILLI-SECOND/DIVISION. Connect the time-mark generator to the vertical INPUT and select time marks of 1 millisecond. Adjust SWEEP CAL (R286, screwdriver adjust on side of sweep chassis) until 10 marks correspond with 10 scale divisions.

Magnifier Gain

8. With the time marks and TIME BASE set as in step 7, turn the 5X MAGNIFIER (red knob center of RANGE switch) to the ON position (clockwise rotation). The HORIZ POSITION should be set so that the center 20 per cent of the display is on the

screen of the tube. Adjust MAG GAIN (R314, screwdriver adjustment on side of sweep chassis) until 2 time marks correspond with 10 scale divisions. A more accurate adjustment may be obtained if the generator is set to 100 MICROSECONDS. Then 20 time marks will occupy 10 divisions. The linearity of the sweep should be carefully checked by noting if each time mark corresponds with a graticule division. If there is any indication that the sweep is not linear, the horizontal output tubes (V224 and V223) should be changed.

Mag. Centering

9. With the same setup as in step 7, position the trace to the right with the HORIZ POSITION control, until the second time mark as displayed on the screen is centered over the center line of the graticule (magnified sweep). Now turn the 5X MAGNIFIER switch to OFF (counter clockwise) and reposition the trace with MAG CENTERING (R306, screwdriver adjust, on side of sweep chassis) until the second time mark is centered on the screen. When this adjustment has been properly made, there will be no movement of the display in the center of the screen as the 5X MAGNIFIER is switched on or off. In other words, the trace will be magnified equally in both directions from center.

NOTE: At this point is recommended that all time-base ranges slower than 1 MILLI-SEC/DIVISION be checked in each of the three MULTIPLIER positions. There should be no error greater than two per cent except at 1, 2, and 5 SEC/DIVISION settings, where the error should not exceed four per cent. Any greater error indicates defective timing resistors or capacitors, or, in the case of the slowest time bases, heater-to-cathode leakage in V213A excessive.

Preliminary Adjustment for High-Speed Trace Linearity

10. If the linearity of the time base has deteriorated, trimmers C260, C276, C290 and C303, located on the underside of the sweep deck should be adjusted for best linearity first before the timing of the 10, 1, or 0.1 MICROSEC/DIVISION time bases is adjusted. If the linearity is good, step 10 may not be necessary. If the linearity needs to be corrected, preset the trimmers as follows:

- C276, minimum capacitance
- C303, minimum capacitance
- C260, half capacitance
- C290, half capacitance

Then the following procedure should be followed in the sequence listed:

- A. Set the TIME BASE RANGE to 10 MICROSEC/DIVISION, MULTIPLIER to 1, and display 10-microsecond time marks. Adjust C290 for best linearity of the first half of the time base.
- B. Make a preliminary adjustment of C280E (lower capacitor on bracket on top of side of chassis) so that 10 markers correspond with 10 graticule divisions.
- C. Change the RANGE control setting to .1 MICROSEC/DIVISION and the MULTIPLIER setting to 5. Display a five-megacycle sine wave and adjust C276 for best linearity of the first half of the sweep.
- D. Reduce the MULTIPLIER control to 1, and advance C250 until the end of the trace just starts to fold over, and then back it off until no fold-over occurs and the linearity of the last of the trace is best.
- E. Advance the MULTIPLIER dial to 2, and adjust C303 for best linearity of the start of the trace.

HIGH-FREQUENCY TIMING

C290 Adjust

11. Set the RANGE to 1 MICROSEC/DIVISION, the MULTIPLIER to 5, and turn the 5X MAGNIFIER to ON. Set the marker generator to give 5-microsecond marks. With the HORIZ POSITION control, position the display so that the first of the sweep is observed. Adjust C290 so that the first two markers occupy 10.1 graticule division.

C280E Adjust

12. With RANGE set to 1 MICROSEC/DIVISION set the MULTIPLIER to X1, and turn the 5X MAGNIFIER to OFF. Set the marker generator to give one-microsecond marks and adjust C280E (located on bracket on tube-side of sweep chassis, lower capacitor nearest switch) so that 10 time marks correspond with 10 scale divisions.

C290 Readjust

13. With the RANGE set to 1 MICROSEC/DIVISION, set the MULTIPLIER to 5X and set the

marker generator for five-microsecond marks. Observe the linearity of the sweep. Readjust C290, if necessary, so that each time mark has the same spacing, without regard to timing. If much adjustment is necessary, step 12 should be repeated.

NOTE: With the RANGE set to 1 MICROSEC/DIVISION the timing accuracy should be checked at the X2 and X5 MULTIPLIER settings. Any error greater than 2% indicates resistors R282A or R282B are defective. If there is any discrepancy it should be averaged between the settings by a compromise setting of C280E. Do not confuse timing error with non-linearity of the sweep.

C280G Adjust (preliminary)

14. Set the RANGE to .1 MICROSEC/DIVISION, set the MULTIPLIER to 5 and set the marker generator for 1- μ sec marks. Adjust C280G so that 5 marks correspond with 10 scale divisions.

C276 Adjust

15. With the same settings as in step 14, change the marker generator to 5 mc, and adjust C276, if necessary, for the best linearity at the start of the sweep.

C280G Adjust

16. With the same settings as in step 15, change the marker generator for 1- μ sec marks and readjust C280G, if necessary, so that 5 marks correspond with 10 scale divisions.

C303 Adjust

17. With the same settings as in step 16 change the MULTIPLIER to X1 and set marker generator to 10 mc. Adjust C303 if necessary so that the center 8 scale divisions correspond with 8 sine waves. Disregard the first and the last marks as there may be a small error if they are used. It may be necessary to repeat step 16 after this adjustment is made. The timing should now be checked in all positions of the MULTIPLIER switch and if any error is found it indicates that the sweep-linearity-setting capacitors C303, C276 or C260, are not properly adjusted.



TYPE 315 CATHODE-RAY OSCILLOSCOPE

DIAGRAMS

Front Panel.....	Page 1
Trigger Selector and Shaper	Page 2
Time Base.....	Page 2
Range and Multiplier Switch Detail	Page 2
Preamp	Page 3
Vertical Amplifier	Page 4
Calibrator	Page 5
Power Supply	Page 5
High Voltage and CRT Circuits	Page 5

TYPE 315 D CATHODE-RAY OSCILLOSCOPE

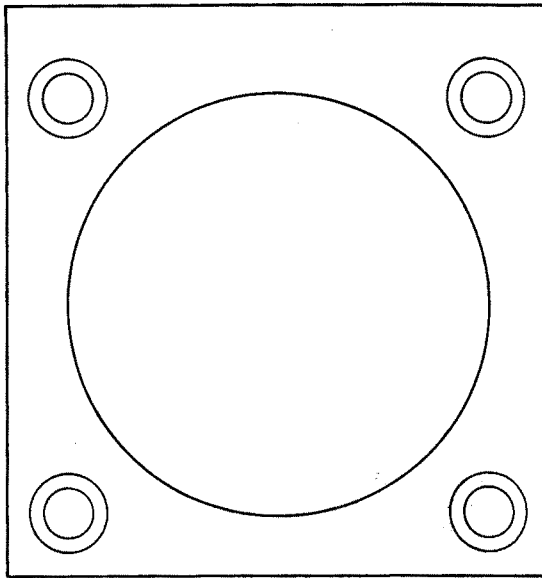

**VERTICAL
AMPLIFIER**

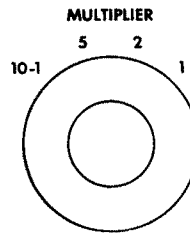

INPUT
1 MEG. 35 MMFD.
600 V. MAX.

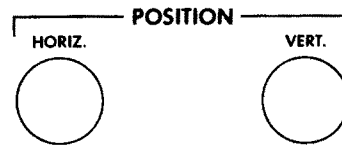
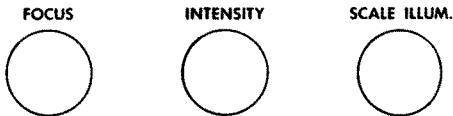
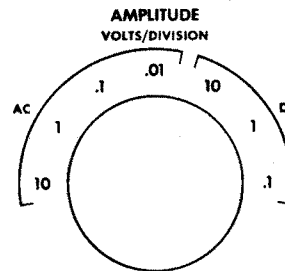
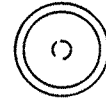

TIME BASE

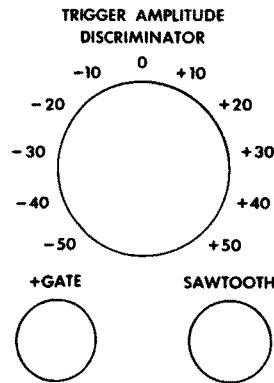
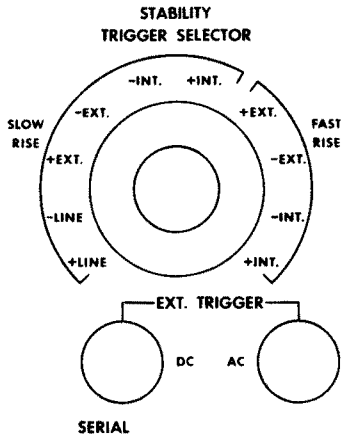
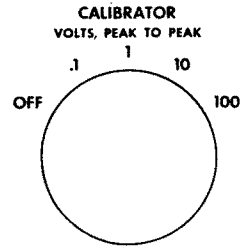
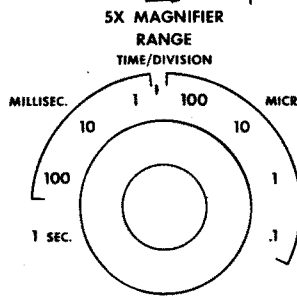
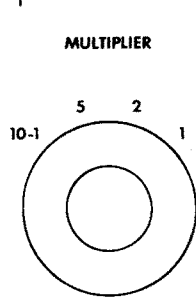

TEKTRONIX, INC., PORTLAND, OREGON, U. S. A.

ABBREVIATIONS

Cer.	ceramic	m	milli or 10 ⁻³
Comp.	composition	Ω	ohm
EMC	electrolytic, metal cased	PMC	paper, metal cased
f	farad	Poly.	polystyrene
GMV	guaranteed minimum value	Prec.	precision
h	henry	PT	paper tubular
k	kilohm or 10 ³ ohms	v	working volts dc
meg	megohm or 10 ⁶ ohms	Var.	variable
μ	micro or 10 ⁻⁶	w	watt
μμ	micromicro or 10 ⁻¹²	WW	wire wound

CALIBRATOR

Capacitors

C601	220 μμf	Mica	Fixed	500 v	20%
C602	220 μμf	Mica	Fixed	500 v	20%
C603	8 μμf	Cer.	Fixed	500 v	25%
C604	47 μμf	Cer.	Fixed	500 v	20%

Resistors

R601	100 k	½ w	Fixed	Comp.	10%
R602	Unassigned				
R603	820 k	½ w	Fixed	Comp.	10%
R604	100 k	½ w	Fixed	Comp.	10%
R605	820 k	½ w	Fixed	Comp.	10%
R610	100 k	1 w	Fixed	Comp.	10%
R611	56 k	½ w	Fixed	Comp.	10%
R612	50 k	2 w	Var.	Comp.	20% CAL. ADJ.
R620	18 k	½ w	Fixed	Prec.	1%
R621	1.8 k	½ w	Fixed	Prec.	1%
R622	180 Ω	½ w	Fixed	Prec.	1%
R623	20 Ω	½ w	Fixed	Prec.	1%

Switches

SW601	1 Wafer	5 Position	CALIBRATOR
-------	---------	------------	------------

Vacuum Tubes

V601	12AT7	Calibrator Multivibrator
V602A	½12AT7	Calibrator-Output Cathode Follower
V602B	½12AT7	Calibrator Amplifier and Shaper

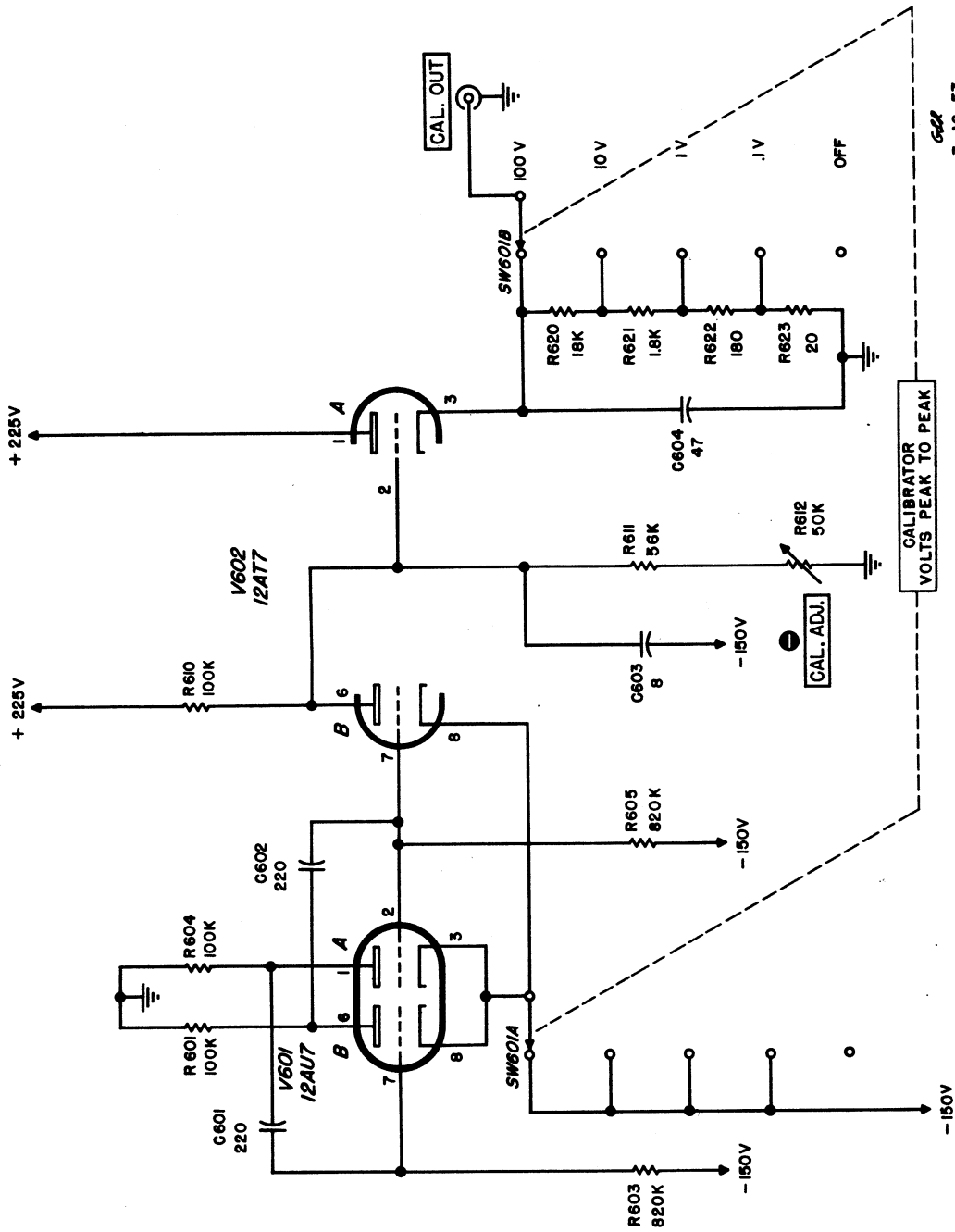

662
3-16-53



CALIBRATOR

TYPE 315 CATHODE-RAY OSCILLOSCOPE

ABBREVIATIONS

Cer.	ceramic	m	milli or 10 ⁻³
Comp.	composition	Ω	ohm
EMC	electrolytic, metal cased	PMC	paper, metal cased
f	farad	Poly.	polystyrene
GMV	guaranteed minimum value	Prec.	precision
h	henry	PT	paper tubular
k	kilohm or 10 ³ ohms	v	working volts dc
meg	megohm or 10 ⁶ ohms	Var.	variable
μ	micro or 10 ⁻⁶	w	watt
μμ	micromicro or 10 ⁻¹²	WW	wire wound

RANGE AND MULTIPLIER SWITCH DETAIL

Capacitors

C241A	.1 μf	PT	Fixed	400 v	20%	} Timing Series See Text
C241B	.01 μf	PT	Fixed	400 v	20%	
C241C	.001 μf	PT	Fixed	600 v	20%	
C241D	100 μμf	Cer.	Fixed	500 v	20%	
C241E	22 μμf	Cer.	Fixed	400 v	20%	
C241F	12 μμf	Cer.	Fixed	500 v	20%	
C280A	1 μf	PMC	Fixed	400 v	Selected	
C280B	.1 μf	PT	Fixed	400 v	Selected	
C280C	.01 μf	PT	Fixed	400 v	Selected	
C280D	.001 μf	PT	Fixed	600 v	Selected	
C280E	7-45 μμf	Cer.	Var.	500 v		
C280F	82 μμf	Cer.	Fixed	500 v	20%	
C280G	3-12 μμf	Cer.	Var.	500 v		
C282	.01 μf	PT	Fixed	400 v	20%	

Resistors

R282A	183 k	½ w	Fixed	Prec.	1%
R282B	60 k	½ w	Fixed	Prec.	1%
R282C	56.5 k	½ w	Fixed	Prec.	1%
R282D	1.84 meg	½ w	Fixed	Prec.	1%
R282E	608 k	½ w	Fixed	Prec.	1%
R282F	608 k	½ w	Fixed	Prec.	1%
R282G	18.6 meg	2 w	Fixed	Prec.	1%
R282H	6.12 meg	½ w	Fixed	Prec.	1%
R282J	6.12 meg	½ w	Fixed	Prec.	1%
R285	10 k	1 w	Fixed	Comp.	10%
R291	3.3 k	½ w	Fixed	Prec.	1%

Switches

SW202	4 Wafer	4 Position	Rotary	SWEEP MULTIPLIER
SW203	4 Wafer	8 Position	Rotary	SWEEP RANGE

L.A.P.
3-16-53

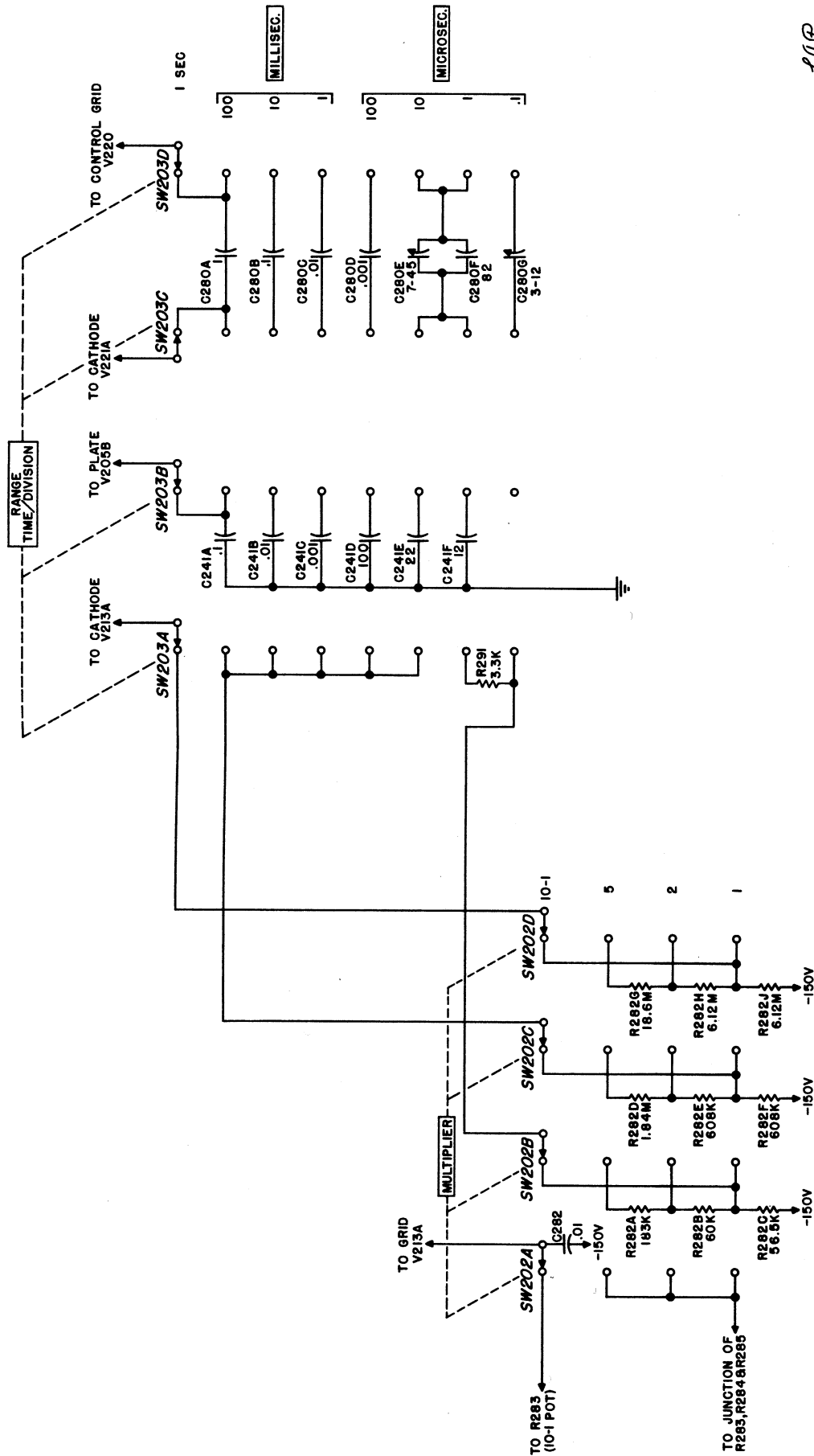

TYPE 315 CATHODE-RAY OSCILLOSCOPE

RANGE 8 MULTIPLIER SWITCH DETAIL

Figure 3

ABBREVIATIONS

Cer.	ceramic	m	milli or 10 ⁻³
Comp.	composition	Ω	ohm
EMC	electrolytic, metal cased	PMC	paper, metal cased
f	farad	Poly.	polystyrene
GMV	guaranteed minimum value	Prec.	precision
h	henry	PT	paper tubular
k	kilohm or 10 ³ ohms	v	working volts dc
meg	megohm or 10 ⁶ ohms	Var.	variable
μ	micro or 10 ⁻⁶	w	watt
μμ	micromicro or 10 ⁻¹²	WW	wire wound

TIME BASE

Capacitors

C244	4.7 μf	Cer.	Fixed	500 v	±1 μf
C250	47 μf	Cer.	Fixed	500 v	20%
C251	12 μf	Cer.	Fixed	500 v	10%
C260	5-20 μf	Cer.	Var.	500 v	
C261	47 μf	Cer.	Fixed	500 v	20%
C262	8 μf	Cer.	Fixed	400 v	±.5 μf
C263	.001 μf	Cer.	Fixed	500 v	GMV
C271	Unassigned				
C272	47 μf	Cer.	Fixed	500 v	20%
C276	1.5-7 μf	Cer.	Var.	500 v	
C282	.01 μf	PT	Fixed	400 v	20%
C290	1.5-7 μf	Cer.	Var.	500 v	
C291	4.7 μf	Cer.	Fixed	500 v	±1 μf
C303	.5-5 μf	Poly.	Var.	500 v	
C325	.01 μf	PT	Fixed	600 v	20%
C326	.01 μf	PT	Fixed	400 v	20%
C327	.01 μf	PT	Fixed	400 v	20%
C328	.01 μf	PT	Fixed	400 v	20%

Resistors

R230	39 k	½ w	Fixed	Comp.	10%	STABILITY
R231	100 k	2 w	Var.	Comp.	20%	
R232	18 k	2 w	Fixed	Comp.	10%	
R233	2.2 k	½ w	Fixed	Comp.	10%	
R234	470 k	½ w	Fixed	Comp.	10%	
R235	680 k	½ w	Fixed	Comp.	10%	
R236	470 Ω	½ w	Fixed	Comp.	10%	
R239	47 Ω	½ w	Fixed	Comp.	10%	
R240	22 k	2 w	Fixed	Comp.	10%	
R241	22 k	½ w	Fixed	Comp.	10%	
R242	10 k	1 w	Fixed	Comp.	10%	(with L246)
R243	390 k	½ w	Fixed	Comp.	10%	
R244	470 k	½ w	Fixed	Comp.	10%	
R245	47 Ω	½ w	Fixed	Comp.	10%	
R246	4.7 k	2 w	Fixed	Comp.	10%	
R247	4.7 k	2 w	Fixed	Comp.	10%	
R248	100 k	1 w	Fixed	Comp.	10%	
R250	150 k	½ w	Fixed	Prec.	1%	
R251	150 k	½ w	Fixed	Comp.	10%	
R252	4.7 k	2 w	Fixed	Comp.	10%	

Resistors (Cont.)

R253	100 k	½ w	Fixed	Comp.	10%	
R254	50 k	2 w	Var.	Comp.	20%	MULTI STABILITY
R255	120 k	½ w	Fixed	Prec.	1%	
R260	700 k	½ w	Fixed	Prec.	1%	
R261	50 k	2 w	Var.	Comp.	20%	SWEEP LENGTH
R262	47 k	1 w	Fixed	Comp.	10%	
R263	1 meg	½ w	Fixed	Comp.	10%	
R264	47 Ω	½ w	Fixed	Comp.	10%	
R265	47 Ω	½ w	Fixed	Comp.	10%	
R270	500 k	½ w	Fixed	Prec.	1%	
R271	100 k	1 w	Fixed	Comp.	10%	
R272	18 k	1 w	Fixed	Comp.	10%	
R273	47 k	2 w	Fixed	Comp.	10%	
R274	22 k	2 w	Fixed	Comp.	10%	
R275	4.7 k	½ w	Fixed	Comp.	10%	
R276	3.9 k	½ w	Fixed	Comp.	10%	
R279	15 Ω	1 w	Fixed	Comp.	10%	
R280	22 k	2 w	Fixed	Comp.	10%	
R281	22 k	2 w	Fixed	Comp.	10%	
R283	500 k	2 w	Var.	Comp.	20%	10-1
R284	18 k	2 w	Fixed	Comp.	10%	
R285	10 k	1 w	Fixed	Comp.	10%	
R286	10 k	2 w	Var.	WW	20%	SWEEP CAL.
R287	8.2 k	½ w	Fixed	Comp.	10%	
R288	20 k	2 w	Var.	Comp.	20%	HORIZ. POSITION
R289	1.75 meg	½ w	Fixed	Prec.	1%	
R290	2.44 meg	½ w	Fixed	Prec.	1%	
R291	3.3 k	½ w	Fixed	Comp.	10%	
R300	200 k	½ w	Fixed	Prec.	1%	
R301	47 k	1 w	Fixed	Comp.	10%	
R302	47 k	1 w	Fixed	Comp.	10%	
R303	700 k	½ w	Fixed	Prec.	1%	
R304	433 k	½ w	Fixed	Prec.	1%	
R305	68 k	1 w	Fixed	Comp.	10%	
R306	10 k	2 w	Var.	WW	20%	MAG. CENTERING
R308	22 k	2 w	Fixed	Comp.	10%	
R309	Unassigned					
R310	20 k	10 w	Fixed	WW	10%	
R311	30 k	10 w	Fixed	WW	10%	
R315	500 Ω	2 w	Var.	Comp.	20%	MAG. GAIN
R316	47 Ω	½ w	Fixed	Comp.	10%	
R317	18 k	2 w	Fixed	Comp.	10%	
R318	20 k	10 w	Fixed	WW	10%	
R319	68 k	2 w	Fixed	Comp.	10%	
R325	47 Ω	½ w	Fixed	Comp.	10%	
R326	47 Ω	½ w	Fixed	Comp.	10%	
R327	47 Ω	½ w	Fixed	Comp.	10%	
R328	47 Ω	½ w	Fixed	Comp.	10%	

Inductors

L246 70 μ h Fixed Wound on R246

Vacuum Tubes

V203	6BQ7	Trigger Amplifier
V204A	1/46BQ7	Trigger Cathode Follower
V204B	1/46BQ7	Sweep Holdoff Cathode Follower
V205A	1/412AT7	Clamp Diode
V205B	1/412AT7	Sweep Holdoff
V210A	1/46BQ7	Unblanking Cathode Follower
V210B	1/46BQ7	Buffer Cathode Follower
V211	6BQ7	Cascode Multivibrator
V212	6BQ7	Cascode Multivibrator
V213A	1/412AT7	Constant Current Tube
V213B	1/412AT7	Multivibrator Reverting Cathode Follower
V214A	1/46U8	Gate-Output Cathode Follower
V214B	1/46U8	Sweep-Clamping Cathode Follower
V215A	1/46AL5	DC Feedback Diode
V215B	1/46AL5	Sweep-Clamping Diode
V220	6AK6	Sweep Generator
V221A	1/46BQ7	Sweep-Out Cathode Follower
V221B	1/46BQ7	Sweep-Position Cathode Follower
V222A	1/46BQ7	Driver Cathode Follower
V222B	1/46BQ7	Sawtooth-Out Cathode Follower
V223A	1/46BQ7	Sweep-Output Cathode Follower
V223B	1/46BQ7	Sweep Amplifier
V224A	1/46BQ7	Sweep-Output Cathode Follower
V224B	1/46BQ7	Sweep Amplifier

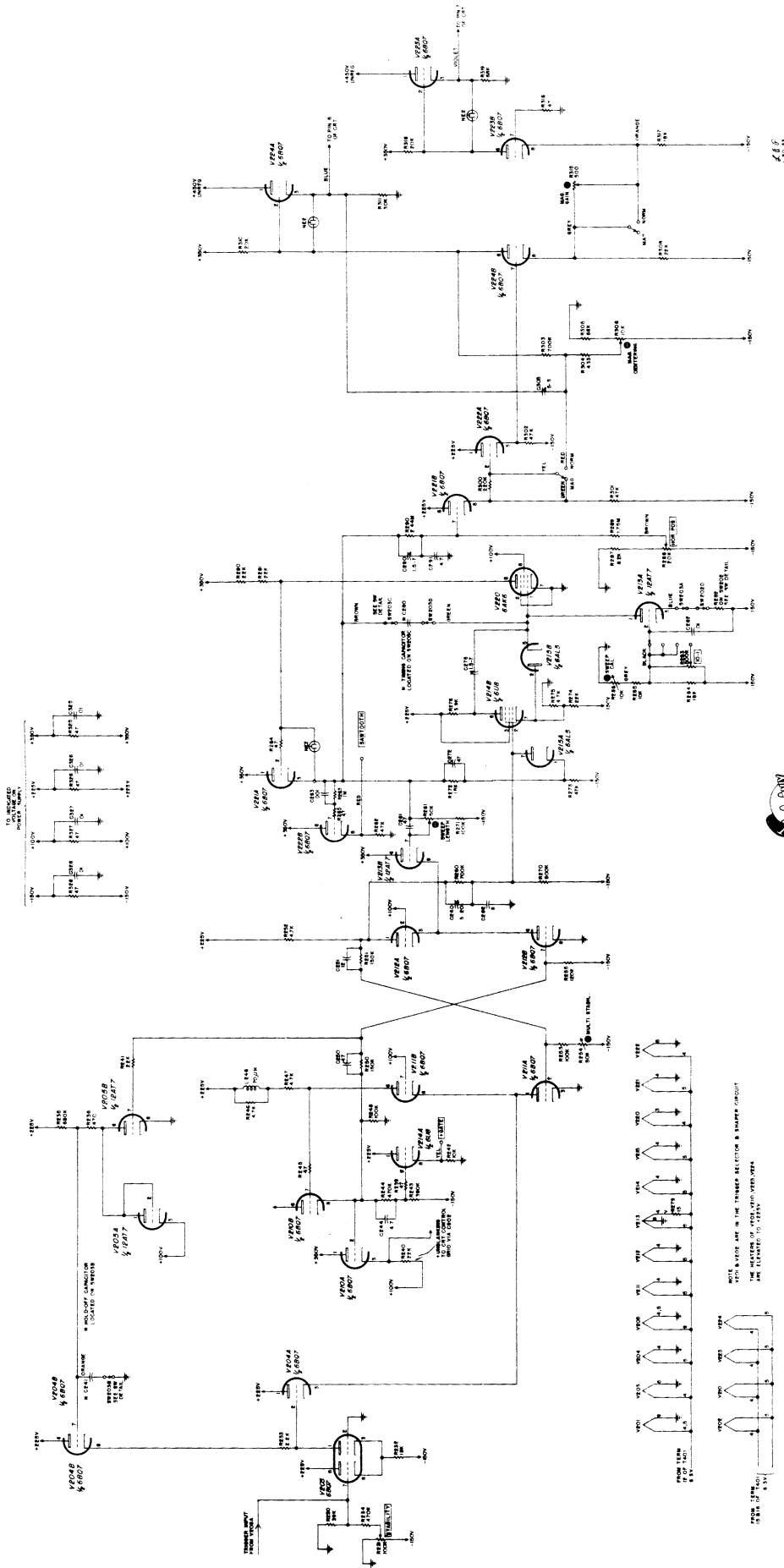

TIME BASE



NOTE: VOLTAGE ARE IN THE TUBES SELECTOR & SHAPER CIRCUIT AND RELATED TO 100V AC.

TYPE 315 CATHODE RAY OSCILLOSCOPE

Figure 4

ABBREVIATIONS

Cer.	ceramic	m	milli or 10 ⁻³
Comp.	composition	Ω	ohm
EMC	electrolytic, metal cased	PMC	paper, metal cased
f	farad	Poly.	polystyrene
GMV	guaranteed minimum value	Prec.	precision
h	henry	PT	paper tubular
k	kilohm or 10 ³ ohms	v	working volts dc
meg	megohm or 10 ⁶ ohms	Var.	variable
μ	micro or 10 ⁻⁶	w	watt
μμ	micromicro or 10 ⁻¹²	WW	wire wound

PREAMP

Capacitors

C1	.1 μf	PT	Fixed	600 v	20%
C2	5-20 μμf	Cer.	Var.	500 v	
C3	1.5-7 μμf	Cer.	Var.	500 v	
C4	27 μμf	Cer.	Fixed	500 v	20%
C5	5-20 μμf	Cer.	Var.	500 v	
C6	1.5-7 μμf	Cer.	Var.	500 v	
C7	330 μμf	Mica	Fixed	500 v	20%
C8	Unassigned				
C9	6.25 μf	EMC	Fixed	300 v	-20% +50%
C10	5-20 μμf	Cer.	Var.	500 v	
C11	6.25 μf	EMC	Fixed	300 v	-20% +50%
C12	.22 μf	PT	Fixed	400 v	20%
C13	.01 μf	Cer.	Fixed	500 v	GMV
C16	.02 μf	Cer.	Fixed	500 v	GMV
C17	.01 μf	Cer.	Fixed	500 v	GMV
C25	.01 μf	Cer.	Fixed	500 v	GMV
C26	.01 μf	Cer.	Fixed	500 v	GMV
C27	.01 μf	Cer.	Fixed	500 v	GMV
C101	3-12 μμf	Cer.	Var.	500 v	

Resistors

R1	900 k	1 w	Fixed	Prec.	1%
R2	111 k	½ w	Fixed	Prec.	1%
R3	990 k	1 w	Fixed	Prec.	1%
R4	10.1 k	½ w	Fixed	Prec.	1%
R5	1 meg	½ w	Fixed	Prec.	1%
R6	Unassigned				
R7	1 meg	½ w	Fixed	Prec.	1%
R10	100 Ω	½ w	Fixed	Comp.	10%
R11	47 Ω	½ w	Fixed	Comp.	10%
R12	47 Ω	½ w	Fixed	Comp.	10%
R13	22 k	2 w	Fixed	Comp.	10%
R14	27 k	2 w	Fixed	Comp.	10%
R15	200 Ω	2 w	Var.	Comp.	20% PREAMP GAIN ADJ
R16	12 Ω	½ w	Fixed	Comp.	10%
R19	6.8 k	½ w	Fixed	Comp.	10%
R20	600 k	½ w	Fixed	Prec.	1%

Resistors (Cont.)

R21	610 k	½ w	Fixed	Prec.	1%
R22	Unassigned				
R23	4.3 k	2 w	Fixed	Comp.	5%
R24	5.6 k	2 w	Fixed	Comp.	10%
R25	5.6 k	2 w	Fixed	Comp.	10%
R30	1 k	2 w	Fixed	Comp.	10%
R31	47 Ω	½ w	Fixed	Comp.	10%
R32	27 k	2 w	Fixed	Comp.	10%
R33	33 k	2 w	Fixed	Comp.	10%
R36	150 Ω	½ w	Fixed	Comp.	10%
R97	100 Ω	½ w	Fixed	Comp.	10%
R98	100 Ω	2 w	Var.	Comp.	20% HUM BALANCE
R101	9 meg	½ w	Fixed	Comp.	10%

Vaccum Tubes

V1	6BQ7	Input Cathode Follower
V2A	½6BQ7	Amplifier
V2B	½6BQ7	Output Cathode Follower

Inductors

L1	2.2-3.9 μh	Var.	CV222
L2	19-35 μh	Var.	CV193

Switches

SW1	2 Wafer	7 Position	Rotary	AMPLITUDE
-----	---------	------------	--------	-----------



Figure 5

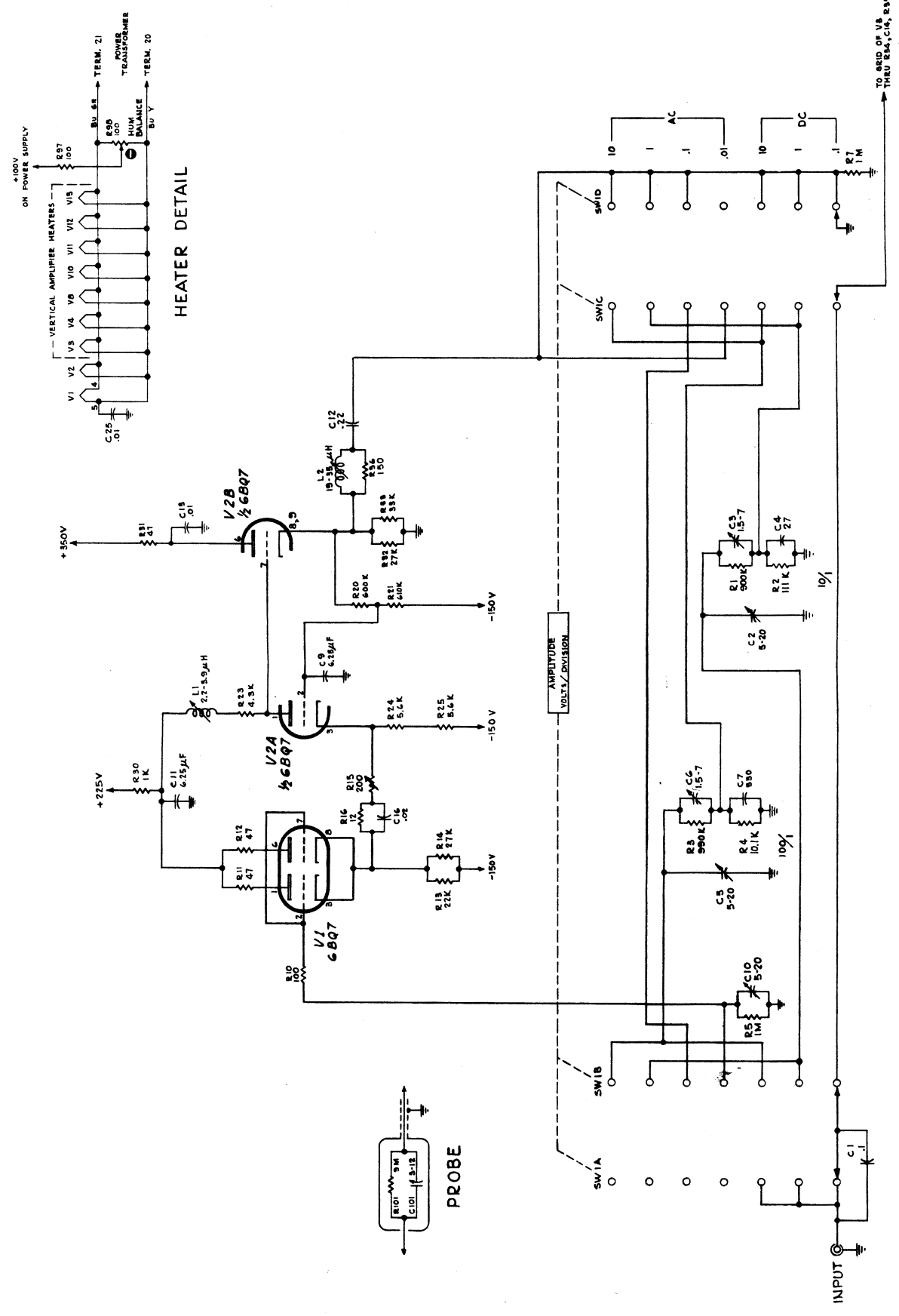

ABBREVIATIONS

Cer.	ceramic	m	milli or 10 ⁻³
Comp.	composition	Ω	ohm
EMC	electrolytic, metal cased	PMC	paper, metal cased
f	farad	Poly.	polystyrene
GMV	guaranteed minimum value	Prec.	precision
h	henry	PT	paper tubular
k	kilohm or 10 ³ ohms	v	working volts dc
meg	megohm or 10 ⁶ ohms	Var.	variable
μ	micro or 10 ⁻⁶	w	watt
μμ	micromicro or 10 ⁻¹²	WW	wire wound

POWER SUPPLY

Capacitors

C401	2x40 μf	EMC	Fixed	250 v	-20%	+50%
C402	125 μf	EMC	Fixed	350 v	-20%	+50%
C403	.01 μf	PT	Fixed	400 v	20%	
C404	.01 μf	PT	Fixed	400 v	20%	
C420	2x40 μf	EMC	Fixed	250 v	-20%	+50%
C421	.01 μf	PT	Fixed	400 v	20%	
C422A	1/3 3x10 μf	EMC	Fixed	450 v	-20%	+50%
C422B	1/3 3x10 μf	EMC	Fixed	450 v	-20%	+50%
C422C	1/3 3x10 μf	EMC	Fixed	450 v	-20%	+50%
C440	2x40 μf	EMC	Fixed	450 v	-20%	+50%
C441	.01 μf	PT	Fixed	400 v	20%	
C460	2x40 μf	EMC	Fixed	250 v	-20%	+50%
C451	.01 μf	PT	Fixed	400 v	20%	

Resistors

R401	39 k	1/2 w	Fixed	Comp.	10%	
R402	47 k	1/2 w	Fixed	Comp.	10%	
R403	12 k	1/2 w	Fixed	Comp.	10%	
R404	1 meg	1/2 w	Fixed	Comp.	10%	
R405	1 k	1/2 w	Fixed	Comp.	10%	
R406	33 k	1/2 w	Fixed	Comp.	10%	
R407	1 meg	1/2 w	Fixed	Comp.	10%	
R408	2 k	20 w	Fixed	WW	5%	
R409	220 k	1/2 w	Fixed	Comp.	10%	
R410	100 k	2 w	Var.	Comp.	20%	ADJ. TO -150 V
R411	270 k	1/2 w	Fixed	Comp.	10%	
R412	50 Ω	2 w	Var.	WW	20%	SCALE ILLUM.
R420	39 k	1/2 w	Fixed	Comp.	10%	
R421	270 k	1/2 w	Fixed	Comp.	10%	
R422	1 meg	1/2 w	Fixed	Comp.	10%	
R423	100 k	1/2 w	Fixed	Comp.	10%	
R424	143 k	1/2 w	Fixed	Prec.	1%	
R425	100 k	1/2 w	Fixed	Prec.	1%	
R440	1.5 meg	1/2 w	Fixed	Comp.	10%	
R441	270 k	1/2 w	Fixed	Comp.	10%	
R442	56 k	1/2 w	Fixed	Comp.	10%	
R443	3.5 k	20 w	Fixed	WW	5%	
R444	220 k	1/2 w	Fixed	Prec.	1%	
R445	143 k	1/2 w	Fixed	Prec.	1%	
R461	27 k	1/2 w	Fixed	Comp.	10%	

Resistors (Cont.)

R462	150 k	2 w	Fixed	Comp.	10%
R463	1.8 meg	½ w	Fixed	Comp.	10%
R464	1.8 meg	½ w	Fixed	Comp.	10%
R465	1.5 k	25 w	Fixed	WW	5%
R467	1.8 meg	½ w	Fixed	Prec.	1%
R468	750 k	½ w	Fixed	Prec.	1%

Switches

SW401	Single Pole	Single Throw	Toggle	POWER
-------	-------------	--------------	--------	-------

Vacuum Tubes

V401	5651	Voltage Reference
V402	6AU6	DC Amplifier, -150v
V403	12B4	Series Regulator, -150v
V404	12B4	Series Regulator, -150v
V421	6AU6	DC Amplifier, +100v
V422	6AS5	Series Regulator, +100v
V441	6AU6	DC Amplifier, +225v
V442A	½6080	Series Regulator, +225v
V442B	½6080	Series Regulator, +350v
V461	6AU6	DC Amplifier, +350v

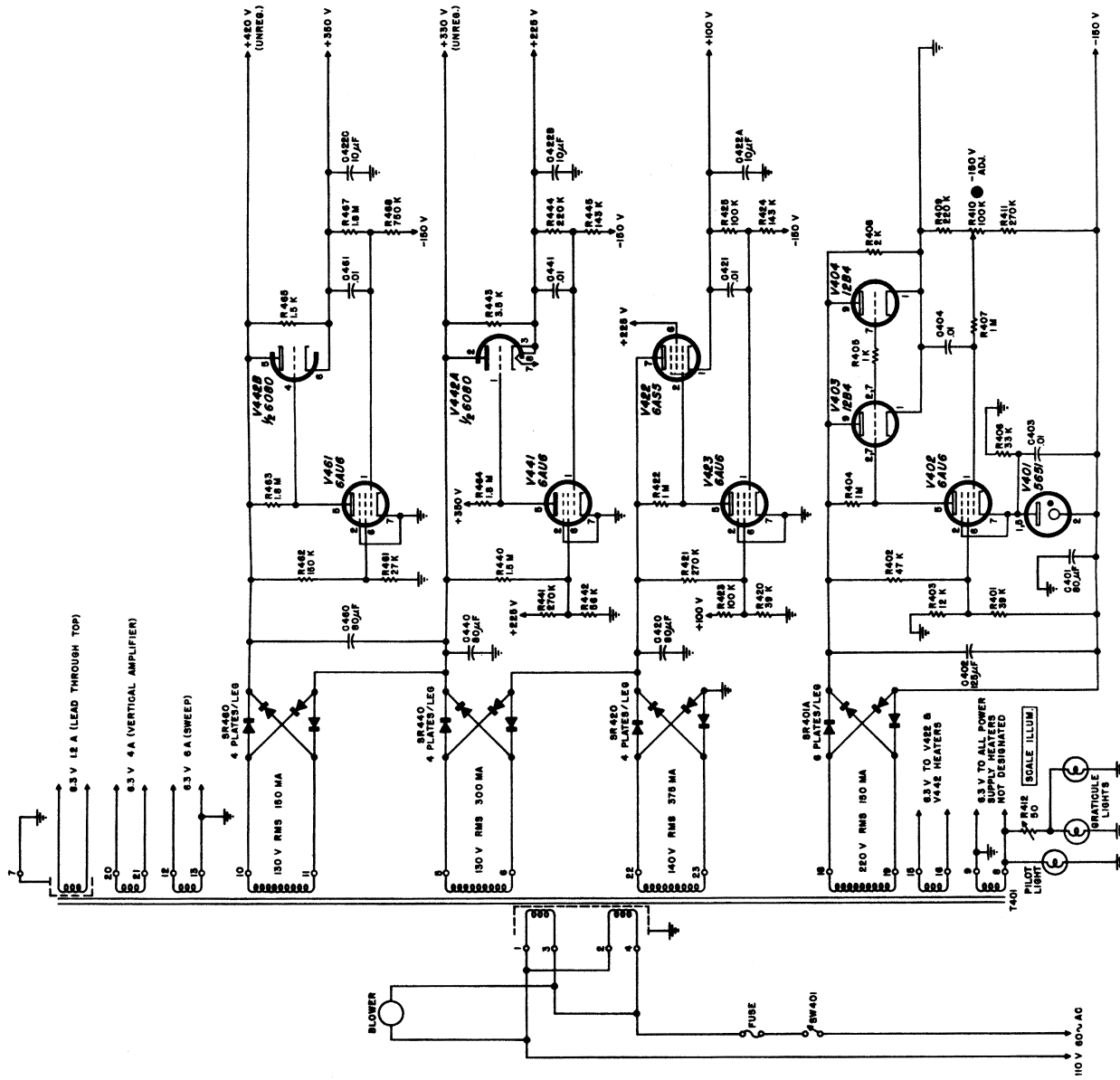

TYPE 315 CATHODE-RAY OSCILLOSCOPE



POWER SUPPLY

8-5-H
3-1E-53

Figure 8

ABBREVIATIONS

Cer.	ceramic	m	milli or 10 ⁻³
Comp.	composition	Ω	ohm
EMC	electrolytic, metal cased	PMC	paper, metal cased
f	farad	Poly.	polystyrene
GMV	guaranteed minimum value	Prec.	precision
h	henry	PT	paper tubular
k	kilohm or 10 ³ ohms	v	working volts dc
meg	megohm or 10 ⁶ ohms	Var.	variable
μ	micro or 10 ⁻⁶	w	watt
μμ	micromicro or 10 ⁻¹²	WW	wire wound

VERTICAL AMPLIFIER

Capacitors

C14	.01 μf	Cer.	Fixed	500 v	GMV
C15	1.5-7 μμf	Cer.	Var.	500 v	
C18	.01 μf	Cer.	Fixed	500 v	GMV
C20	.01 μf	PT	Fixed	400 v	20%
C21	6.25 μf	EMC	Fixed	300 v	-20% +50%
C22	.01 μf	PT	Fixed	400 v	20%

Delay Line Capacitors

C501	1.5-7 μμf	Cer.	Var.	500 v
C502A-E	5-25 μμf	Cer.	Var.	500 v
C511A-F	5-25 μμf	Cer.	Var.	500 v
C521A-F	5-25 μμf	Cer.	Var.	500 v
C522	1.5-7 μμf	Cer.	Var.	500 v

Inductors

L3	4.8-8.5 μh	Var.	CV482
L4	28-50 μh	Var.	CV283
L5	28-50 μh	Var.	CV283
L6	50-96 μh	Var.	CV513
L7	50-96 μh	Var.	CV513

Resistors

R34	100 k	½ w	Fixed	Comp.	10%
R35	47 Ω	½ w	Fixed	Comp.	10%
R40	2.2 k	1 w	Fixed	Comp.	10%
R41	47 Ω	½ w	Fixed	Comp.	10%
R42	1 k	½ w	Fixed	Comp.	10%
R43	Unassigned				
R44	8 k	5 w	Fixed	WW	5%
R45	8 k	5 w	Fixed	WW	5%
R46	27 Ω	½ w	Fixed	Comp.	10%
R50	470 Ω	½ w	Fixed	Comp.	10%
R51	2.5 k	1/10 w	Var.	Comp.	20%
R52	1.2 k	½ w	Fixed	Comp.	10%
R53	10 k	1/10 w	Var.	Comp.	20%
R54	2250 Ω	2 w	Var.	Comp.	20% 10-1
R55	5 k	2 w	Var.	Comp.	20% VERT. AMPL. DC BAL.

Resistors (Cont.)

R59	12 Ω	$\frac{1}{2}$ w	Fixed	Comp	10%	
R60	47 Ω	$\frac{1}{2}$ w	Fixed	Comp.	10%	
R61	47 Ω	$\frac{1}{2}$ w	Fixed	Comp.	10%	
R62	12 k	2 w	Fixed	Comp.	10%	
R63	470 k	$\frac{1}{2}$ w	Fixed	Comp.	10%	
R64	12 k	2 w	Fixed	Comp.	10%	
R65	220 k	$\frac{1}{2}$ w	Fixed	Prec.	1%	
R66	22 k	$\frac{1}{2}$ w	Fixed	Comp.	10%	
R69	22 k	$\frac{1}{2}$ w	Fixed	Comp.	5%	
R70	250 k	2 w	Var.	Comp.	20%	VERT. POSITION
R71	27 Ω	$\frac{1}{2}$ w	Fixed	Comp.	10%	
R72	10 Ω	$\frac{1}{2}$ w	Fixed	Comp.	10%	
R73	27 Ω	$\frac{1}{2}$ w	Fixed	Comp.	10%	
R74	10 Ω	$\frac{1}{2}$ w	Fixed	Comp.	10%	
R75	2 k	5 w	Fixed	WW	5%	
R76	2 k	5 w	Fixed	WW	5%	
R80	2.5 k	10 w	Fixed	WW (non-inductive)	5%	
R81	6.8 k	$\frac{1}{2}$ w	Fixed	Comp.	10%	
R82	47 Ω	$\frac{1}{2}$ w	Fixed	Comp.	10%	
R83	750 Ω	10 w	Fixed	WW	5%	
R84	2.5 k	10 w	Fixed	WW (non-inductive)	5%	
R85	6.8 k	$\frac{1}{2}$ w	Fixed	Comp.	10%	
R90	100 Ω	2 w	Var.	Comp.	20%	SENSITIVITY ADJUST
R91	10 Ω	$\frac{1}{2}$ w	Fixed	Comp.	10%	
R92	27 Ω	$\frac{1}{2}$ w	Fixed	Comp.	10%	
R93	27 Ω	$\frac{1}{2}$ w	Fixed	Comp.	10%	
R94	10 Ω	$\frac{1}{2}$ w	Fixed	Comp.	10%	
R95	47 Ω	$\frac{1}{2}$ w	Fixed	Comp.	10%	
R521	1.1 k	1 w	Fixed	Prec.	1%	

Switches

SW2	1 Wafer	4 Position	Rotary	MULTIPLIER
-----	---------	------------	--------	------------

Vacuum Tubes

V3	6CL6	Gain-Control Stage Input
V4	6CL6	Gain-Control Stage Output
V8A	$\frac{1}{2}$ 6BQ7	Vertical-Position Cathode Follower
V8B	$\frac{1}{2}$ 6BQ7	Driver Cathode Follower
V10	12BY7	Vertical-Output Amplifier
V11	12BY7	Vertical-Output Amplifier
V12	12BY7	Vertical-Output Amplifier
V13	12BY7	Vertical-Output Amplifier

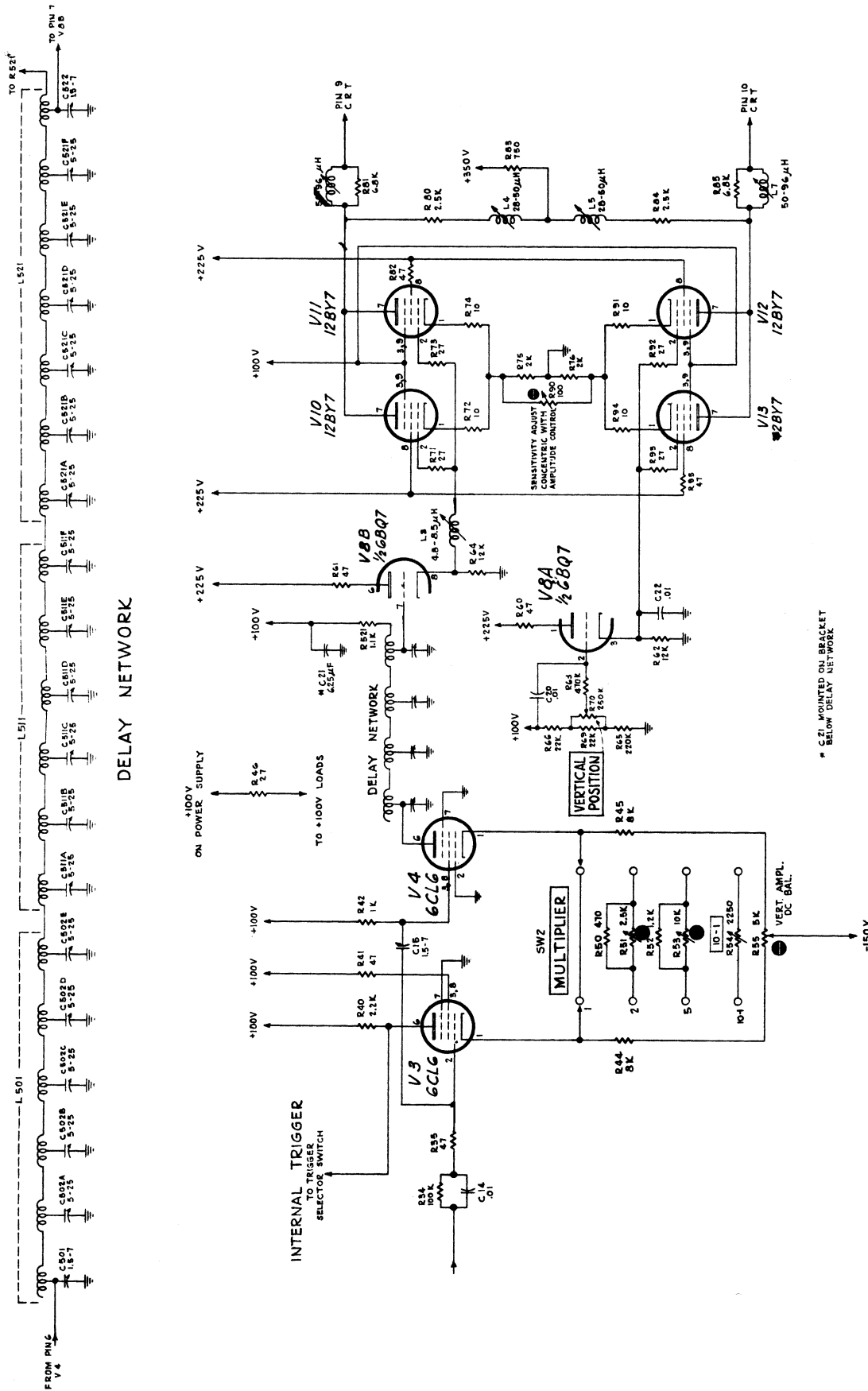

ABBREVIATIONS

Cer.	ceramic	m	milli or 10 ⁻³
Comp.	composition	Ω	ohm
EMC	electrolytic, metal cased	PMC	paper, metal cased
f	farad	Poly.	polystyrene
GMV	guaranteed minimum value	Prec.	precision
h	henry	PT	paper tubular
k	kilohm or 10 ³ ohms	v	working volts dc
meg	megohm or 10 ⁶ ohms	Var.	variable
μ	micro or 10 ⁻⁶	w	watt
μμ	micromicro or 10 ⁻¹²	WW	wire wound

TRIGGER SELECTOR AND SHAPER

Capacitors

C200	.047 μf	PT	Fixed	400 v	20%
C201	.001 μf	Cer.	Fixed	500 v	GMV
C202	12 μμf	Cer.	Fixed	500 v	10%
C212	.001 μf	Cer.	Fixed	500 v	GMV
C221	.001 μf	Cer.	Fixed	500 v	GMV
C222	Unassigned				
C223	470 μμf	Cer.	Fixed	500 v	20%
C227	22 μμf	Cer.	Fixed	400 v	20%

Resistors

R200	1 meg	½ w	Fixed	Comp.	10%
R201	1 meg	½ w	Fixed	Comp.	10%
R202	10 k	1/10 w	Var.	Comp.	20%
R203	50 k	½ w	Fixed	Prec.	1%
R204	100 k	½ w	Fixed	Prec.	1%
R208	4.7 k	1 w	Fixed	Comp.	10%
R209	4.7 k	1 w	Fixed	Comp.	10%
R210	18 k	2 w	Fixed	Comp.	10%
R211	47 k	½ w	Fixed	Comp.	10%
R212	100 k	2 w	Var.	Comp.	20%
TRIGGER AMPLITUDE DISCRIMINATOR					
R215	100 k	½ w	Fixed	Comp.	10%
R216	560 k	½ w	Fixed	Comp.	10%
R217	390 k	½ w	Fixed	Comp.	10%
R220	2.2 k	½ w	Fixed	Comp.	10%
R221	1.5 k	1 w	Fixed	Comp.	10% (with L221)
R222	47 Ω	½ w	Fixed	Comp.	10%
R223	500 Ω	2 w	Var.	Comp.	20%
R224	22 k	1 w	Fixed	Comp.	10%
R225	22 k	1 w	Fixed	Comp.	10%
R226	150 k	½ w	Fixed	Prec.	1%
R227	95 k	½ w	Fixed	Prec.	1%
TRIG. SENS.					

Switches

SW201	3 Wafer	10 Position	Rotary	TRIGGER SELECTOR
-------	---------	-------------	--------	------------------

Inductors

L221	150 μh	Fixed	Wound on R221
------	--------	-------	---------------

Vacuum Tubes

V201	12AT7	Trigger Phase Invertor
V202	6U8	Regenerative Trigger Amplifier

TRIGGER SELECTOR

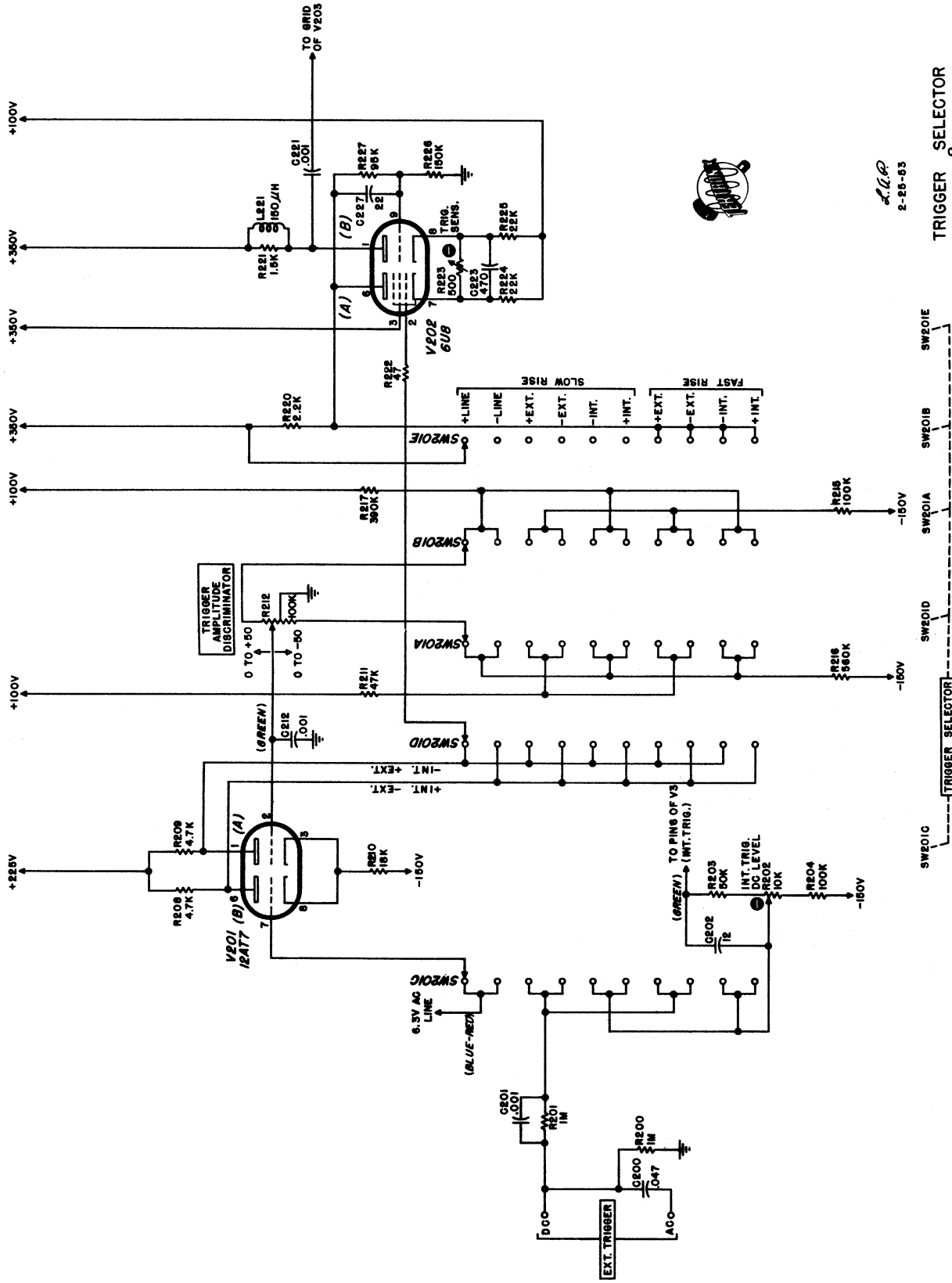

TYPE 315 CATHODE-RAY OSCILLOSCOPE

TRIGGER SELECTOR

SHAPER

TRIGGER SELECTOR

TRIGGER SELECTOR

SHAPER

L.L.P.
2-25-63

Figure 2

ABBREVIATIONS

Cer.	ceramic	m	milli or 10 ⁻³
Comp.	composition	Ω	ohm
EMC	electrolytic, metal cased	PMC	paper, metal cased
f	farad	Poly.	polystyrene
GMV	guaranteed minimum value	Prec.	precision
h	henry	PT	paper tubular
k	kilohm or 10 ³ ohms	v	working volts dc
meg	megohm or 10 ⁶ ohms	Var.	variable
μ	micro or 10 ⁻⁶	w	watt
μμ	micromicro or 10 ⁻¹²	WW	wire wound

HIGH VOLTAGE AND CRT CIRCUITS

Capacitors

C802	.001 μf	Cer.	Fixed	500 v	GMV
C803	Unassigned				
C804	.001 μf	PT	Fixed	600 v	20%
C805	.001 μf	PT	Fixed	600 v	20%
C815	.0068 μf	PT	Fixed	3000 v	20%
C816	.0068 μf	PT	Fixed	3000 v	20%
C817	.022 μf	PT	Fixed	400 v	20%
C818	.0068 μf	PT	Fixed	3000 v	20%
C901	.015 μf	PT	Fixed	3000 v	20%
C902	.015 μf	PT	Fixed	3000 v	20%

Resistors

R802	1 meg	½ w	Fixed	Comp.	10%
R803	47 k	2 w	Fixed	Comp.	10%
R804	1.5 k	½ w	Fixed	Comp.	10%
R805	47 k	½ w	Fixed	Comp.	10%
R816	1.2 meg	½ w	Fixed	Comp.	10%
R817	2 meg	2 w	Var.	Comp.	20% H.V. ADJUST
R901	27 k	½ w	Fixed	Comp.	10%
R902	1.5 meg	½ w	Fixed	Comp.	10%
R903	2 meg	½ w	Var.	Comp.	20% FOCUS
R904	3.9 meg	2 w	Fixed	Comp.	10%
R905	1 meg	½ w	Fixed	Comp.	10%
R910	1 meg	½ w	Var.	Comp.	20% INTENSITY
R911	1.5 meg	½ w	Fixed	Comp.	10%
R912	5.6 meg	2 w	Fixed	Comp.	10%
R913	5.6 meg	2 w	Fixed	Comp.	10%
R914	100 k	½ w	Fixed	Comp.	10%
R920	20 k	2 w	Var.	Comp.	20% ASTIGMATISM

Vacuum Tubes

V801A	½12AT7	DC Amplifier
V801B	½12AT7	Shunt Regulator
V803	6AQ5	High-Voltage Oscillator
V804	5642	High-Voltage Rectifier
V805	5642	High-Voltage Rectifier

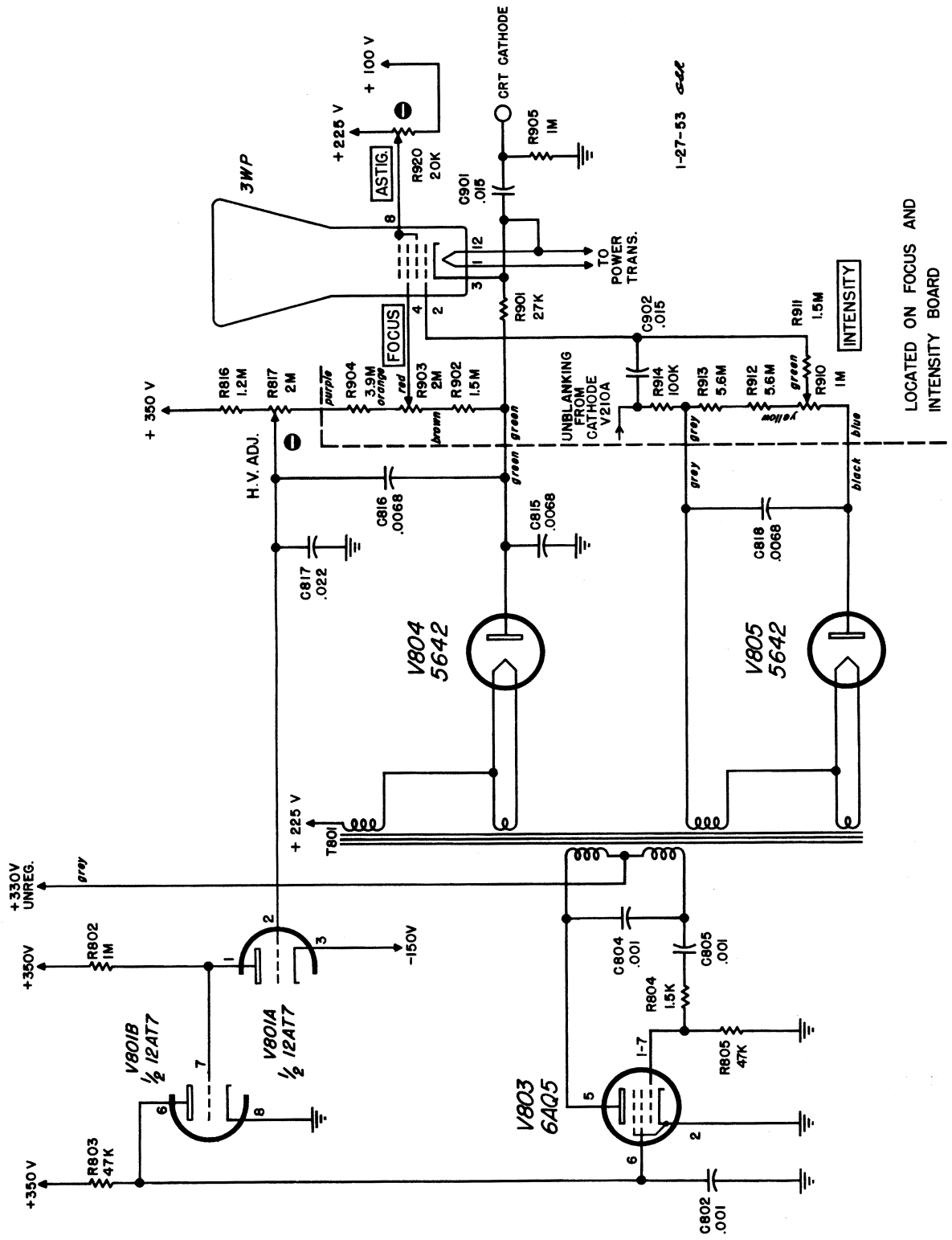

1-27-53 *cdl*

LOCATED ON FOCUS AND INTENSITY BOARD

HIGH VOLTAGE AND CRT CIRCUITS

TYPE 315 CATHODE-RAY OSCILLOSCOPE