

See discussions, stats, and author profiles for this publication at: <https://www.researchgate.net/publication/264578943>

RF Probe Technology: History and Selected Topics

Article in IEEE Microwave Magazine · November 2013

DOI: 10.1109/MMM.2013.2280241

CITATIONS

28

READS

6,951

2 authors:



[Andrej Rumiantsev](#)

MPI Corporation

49 PUBLICATIONS 461 CITATIONS

[SEE PROFILE](#)



[Ralf Doerner](#)

Ferdinand-Braun-Institut

117 PUBLICATIONS 1,258 CITATIONS

[SEE PROFILE](#)

Some of the authors of this publication are also working on these related projects:



mmwave and THz MMIC circuit design [View project](#)



Mixed frequency S-parameter measurements [View project](#)

RF Probe Technology

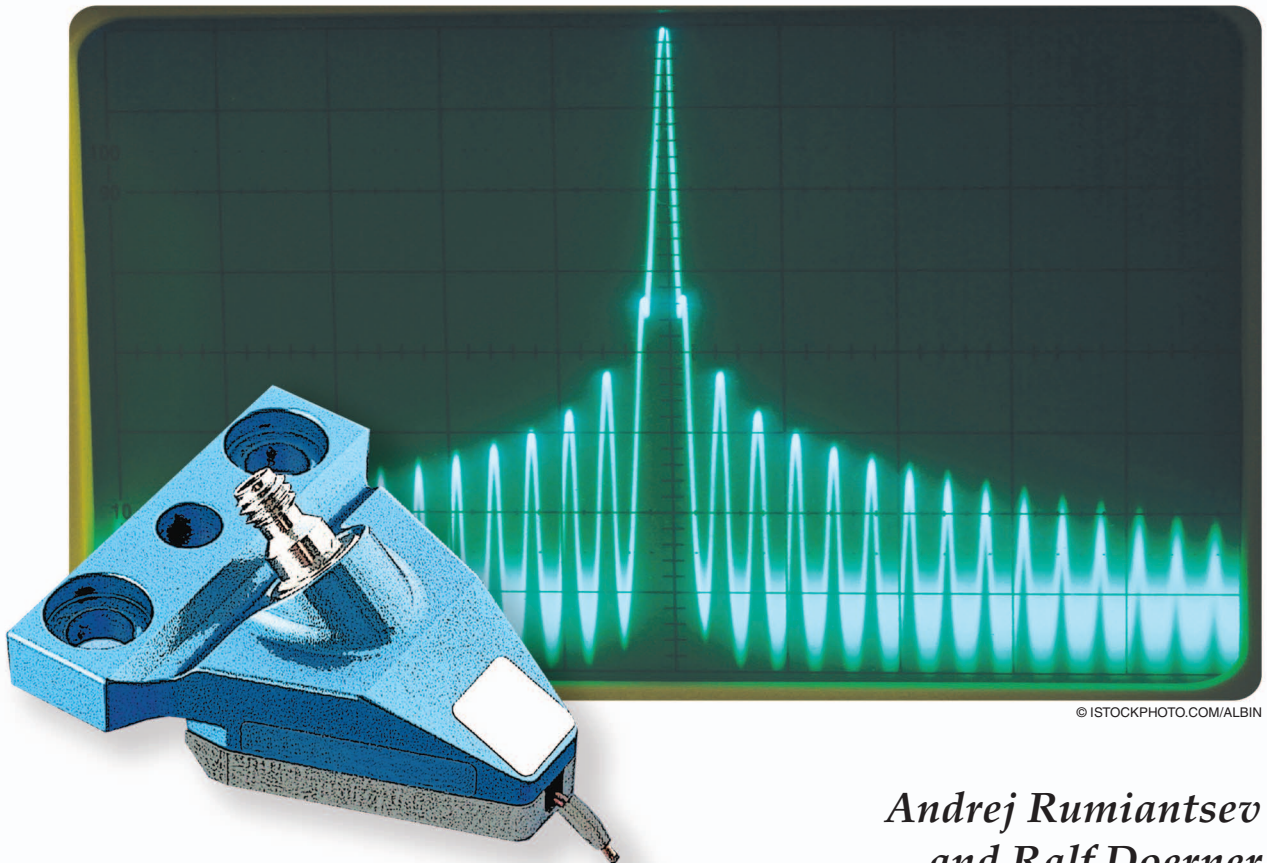

© ISTOCKPHOTO.COM/ALBIN

*Andrej Rumiantsev
and Ralf Doerner*

Today, radio-frequency (RF) wafer probes play an important role in almost every step of the RF products lifecycle: from technology development, model parameter extraction, design verification, and debug to small-scale and final production test. By using RF probes, it became possible to measure true characteristics of the RF components at the wafer level. This halved research and development times

and lowered the enormous costs of developing new products.

Within only three decades, RF probing technology made amazing progress from “it cannot be done” (late 1970s [1], [2]) to commercially available solutions for an extremely wide application range: impedance matching, multiport, differential and mixed-signal measurement up to 110 GHz (e.g., [3], [4]), temperatures beyond 500 °C [5] and down to 4 K (e.g., [6]–[8]), high-power

Andrej Rumiantsev (Andrej.Rumiantsev@tu-cottbus.de) is with the Brandenburg University of Technology, Cottbus, Germany. Ralf Doerner is with Ferdinand-Braun-Institut, Leibniz-Institut fuer Hoechstfrequenztechnik, Berlin, Germany.

*Digital Object Identifier 10.1109/MMM.2013.2280241
Date of publication: 15 November 2013*

measurements up to 60 W in continuous-wave mode [9], and terahertz (THz) applications up to 750 GHz (Figure 1) [10], [11].

Prior to writing this article, through the course of our discussions, we realized that it would not be possible to cover all important aspects of the development of RF wafer-level measurement technologies in one article. Hence, we decided instead to publish a series of articles, each highlighting selected aspects of the given field. This article discusses the history of RF probes.

Conference papers and journal articles naturally present technical achievements and results. Many interesting stories about how researchers and engineers managed to overcome difficulties and finally found smart solutions remained untold and later fell into oblivion. We are really glad that Ed Godshalk (see “The Story of the Waveguide Input Wafer Probe and the Air Coplanar Wafer Probe”) and Scott Barker (see “Micro-machined On-Wafer Probe Technology”), who greatly contributed to important milestones of RF probing technology, agreed to share with all of us their stories on waveguide WPH, air coplanar (ACP) and Dominion MicroProbes, Inc. (DMPI) probes.

First Steps

One of the earliest measurement results obtained using RF probes were presented in [12], demonstrating usable device data up to 4 GHz. The probes used in this experiment were very different from today’s tools. The probe used convergent 50-Ω microstrip lines with a short wire tip, contacting the device-under-test (DUT) pads through a hole in the probe substrate. Such a concept of building a wafer probe was further studied in [13], where the level of difficulty was to achieve repeatable measurements above 4 GHz. While it was possible to remove the impact of relatively large series inductance of a contact wire tip by the calibration procedure, the authors of [13] observed large changes in the radiation impedance of the wire tip when the wafer chuck was moved. It became obvious that the design of contact tips should be different from those used at dc and low frequency measurements: it is essential to bring the 50-Ω environment very close to the DUT pads.

To our understanding, [13] and [14] provided a real breakthrough in probe technology. The basic requirements and operation principles of an RF probe were defined, and, since then, the following have come to be seen as common rules for decades:

- 1) The 50-Ω planar transmission line of the probe should be brought in contact with DUT pads directly, without contact wires. For microstrip and later coplanar probe design, the probe contacts were realized as small gold balls, large enough to ensure reliable and repeatable contact.
- 2) Tilting of the probe is required to contact the DUT signal and ground pads simultaneously. This procedure is called “probe planarization.”

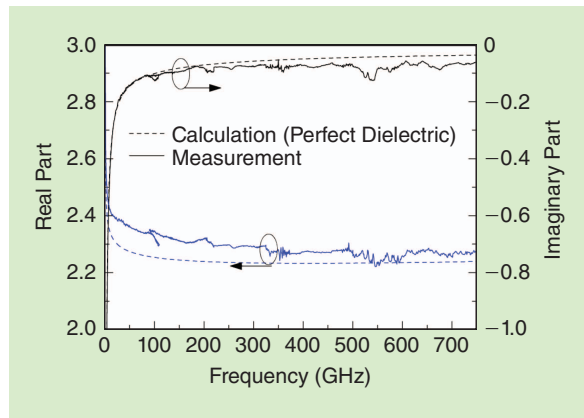

Figure 1. The first report of on-wafer measurements for frequencies from a few MHz to 750 GHz (in multiple bands). The real and imaginary parts of the measured effective dielectric constant, as determined by TRL calibration on microstrip lines, formed on a thin bisbenzocyclobutene-based (BCB) monomers film. (Figure from [11].)

- 3) The contact repeatability of the probe is much better than that of the coaxial connector. This finding has facilitated the development of probe-tips and on-wafer standards and dedicated calibration methods.
- 4) The high contact repeatability allowed accurate calibration of the probe and shifting of the measurement reference plane to its tips. The probe losses and reflections from the probe lines and transition to coaxial connector were cancelled out in a similar way as errors due to the RF cables and connectors.
- 5) It was demonstrated that, due to their small geometrical sizes, an equivalent model of planar standards can be assumed to be purely lumped. Moreover, model parameters can easily be predicted from geometrical dimensions of the standard.

With transferring the probe design from microstrip to the coplanar waveguide (CPW), the probes became very simple to fabricate (Figure 2) [15]. Tektronix finally transformed probes from a “do-it-yourself” tool to a real product for the evolving RF semiconductor

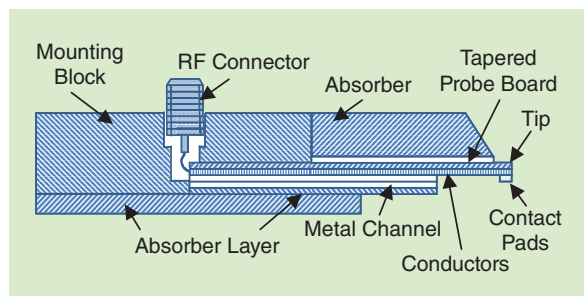

Figure 2. Design of the wafer probes based on the ceramic coplanar line.

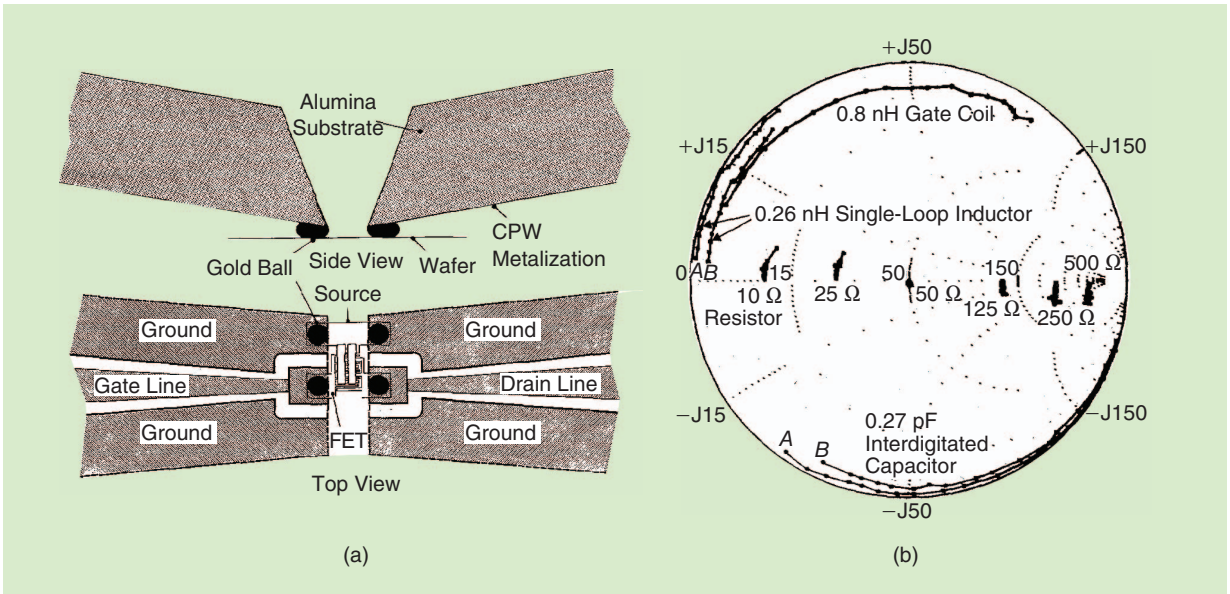

Figure 3. (a) Top and side view of the coplanar probes and (b) corrected one-port measurements of various on-wafer impedance standards (from [14]).

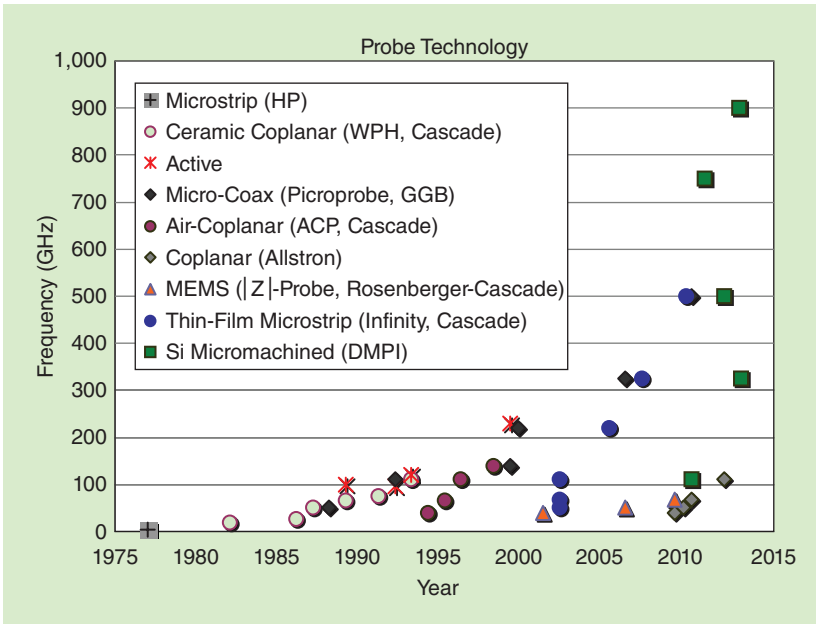

Figure 4. Progress of the RF probing technology.

industry (Figure 3) [14]. This heralded the beginning of the wafer-level RF measurements era.

RF Probe Technology Progress

Today, a whole range of vendors offer RF probes. We tried to reconstruct the evolution of probe technologies to the best we could. Figure 4 shows the progress of RF probing technology over years: the frequency capabilities of RF probes increases exponentially, new probe technologies come to place, and the list of probe manufactures expands. While some dates may not be absolutely precise, these do not influence the entire picture.

TMP (Tektronix) and WPH (Cascade Microtech)

In the beginning of the 1980s, Tektronix launched the very first RF wafer probe model TMP9600 and the sapphire calibration substrate CAL96 (Figure 5) [16], [17]. Eric Strid and Reed Gleason, the principal developers of the probes, left Tektronix, licensed TMP probe technology, and founded Cascade Microtech in 1983 [18]. Both companies had been offering similar RF probes for several years until Tektronix finally stepped out of the wafer probe business in the beginning of the 1990s (Figure 6). As a consequence of this as well as due to its good relationship with Hewlett Packard, Cascade Microtech became the key supplier of RF probes for the industry [19]–[21].

The WPH frequency range quickly expanded to 26 GHz [22] and, in 1987, to 50 GHz to satisfy the needs of the rapidly developing monolithic microwave integrated circuits (MMICs) [23]. The V-band and W-band WPH probes became available in 1991 and 1993, respectively [24], [25]. In “The Story of the Waveguide Input Wafer Probe and the Air Coplanar Wafer Probe,” Ed Godshalk presents a vivid story on how this technology leap was made, revealing an exciting view behind the scene.

In 1988, Cascade introduced a series of 26.5-GHz replaceable-tip probes (RTPs) for volume-production applications [26]. Now the ceramic tip could be quickly

The Story of the Waveguide Input Wafer Probe and the Air Coplanar Wafer Probe

I attended graduate school at Washington University in St. Louis, Missouri, under the late Dr. Fred Rosenbaum, where I worked with ridge waveguide and other components. After I graduated in 1983, I joined Fred at Central Microwave to develop Gunn oscillators and ferrite devices. I still remember seeing press releases of the first wafer probes from Cascade Microtech, but I did not have a need for them at the time since I lived in the world of waveguides. In 1985, I joined Millitech Corp. in South Deerfield to develop digital radios to 135 GHz, Gunn oscillators for the UARS-MLS satellite to study ozone depletion in the atmosphere, and components such as commercial ferrite Y-junction circulators in the 120–180 GHz range.

My wife and I moved to Oregon in late 1989 when she accepted a job at Tektronix. On a whim, I wrote an unsolicited letter to Cascade Microtech seeking employment, since I was impressed by their latest probes that worked up to 60 GHz. I received prompt feedback inviting me to interview with them. At the interview, I met with Eric Strid, who founded the company with Reed Gleason and Dale Carlton. Later that morning, I was interviewed by Keith Jones, who managed the Engineering Group. Keith surprised me when he asked me about waveguides since, at that time, the probes made by Cascade were all coaxial based. Keith asked if I was familiar with ridge waveguide, and keeping a poker face, I said “yes.” He then prodded me to expand on this topic. I will be eternally grateful to Fred Rosenbaum, since I was able to calmly derive the transverse wave equations and describe the broad band characteristics of ridge

waveguide in detail. Keith got excited and then revealed that Cascade had been awarded a contract by Defence Advanced Research Projects Agency (DARPA) to develop a waveguide input wafer probe since the state of the art 1.85-mm coaxial connector was limited to 60 GHz.

DARPA wanted to develop MIMICs at millimeter-wave frequencies for use in radar, communications, and imaging. A consortium of partners including Thompson Ramo Wooldridge, Inc. (TRW), National Institute of Standards and Technology (NIST), and Cascade, teamed up to develop MIMIC devices and the measurement techniques and tools required to achieve this goal. Phase 1 was to develop a V-band (50–75 GHz) waveguide input wafer probe to prove the concept, followed by W-band (75–110 GHz). Cascade had been awarded the contract but did not have anyone on the staff with waveguide experience and the clock was ticking on the due date. Based on this urgent need, the interview came to a quick conclusion. The next interviewer was Reed Gleason, and when he came into the room, he simply said “Let’s go to lunch, the interview is over—they decided to offer you a job.”

I joined Cascade in November 1989 and was put on a tight time line to make progress on the contract. The challenge was how to transition the rectangular waveguide of the V-band vector network analyzer to the coplanar waveguide (CPW) alumina tip that Cascade had developed for coax-based wafer probes. I designed a binomial transformer, consisting of a series of the rectangular waveguide quarter-wavelength sections

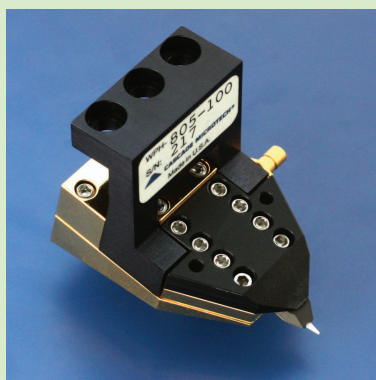

(a)

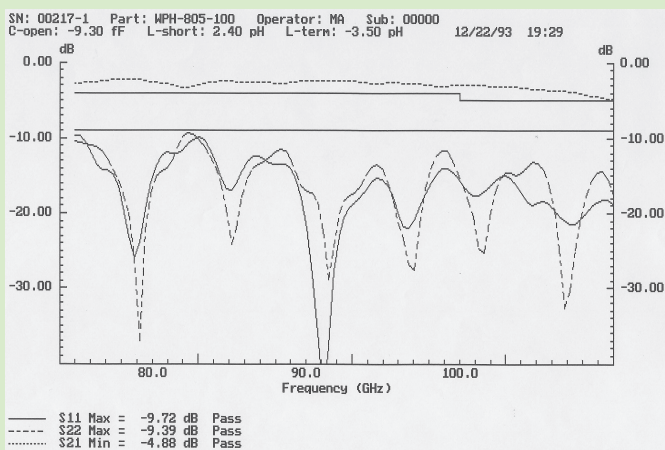

(b)

Figure S1. (a) A W-Band WPH Probe model 805-100, SN217 and (b) its electrical characteristics, Dec. 1993. [Pictures courtesy of Ferdinand-Braun-Institut (FBH).]

to transition the high impedance of the rectangular waveguide ($\sim 450 \Omega$) down to a $50\text{-}\Omega$ ridge waveguide having a quasi-transverse-electromagnetic (quasi-TEM). Next, a trough was introduced under the ridge, and by gradually dropping the ridge into the trough the quasi-TEM field pattern was split into a CPW mode while maintaining 50Ω . I called this "ridge-trough waveguide (RTW)," and a patent was issued on it [S3]. The RTW was then connected to the alumina probe tip using a clamp structure.

Readers need to appreciate that was at the dawn of EM simulators and Zoltan Cendes and his brother Nick were just then introducing the high-frequency structural simulator (HFSS) in a partnership between their new company Ansoft and Hewlett Packard. We did not have access to this tool at the time, so I wrote a program in Pascal to compute the impedances and waveguide wavelengths for a wide variety of ridge and RTW cross-sections to create a design guide. This is described in detail in a paper in *IEEE Transactions on Microwave Theory and Techniques* [S1]. To test the transition, I fabricated a 25x scale model to scale V-band down to 2–3 GHz where I could use a vector network analyzer with a time-domain reflectometry (TDR) option. When I first tested it there was a glitch in the TDR response, and I suspected that one of the quarter wave sections was to blame. I simply stuck a screwdriver into the waveguide CPW end and located the offending section by observing when the large reflection from the screwdriver blade coincided with the glitch. Sure enough, the section had not been machined correctly so I took it into the machine shop and fixed it. Once I put it back together the results were immediate and gratifying, since it worked well in terms of return loss and insertion loss. Using this transition, the V-band probe was developed and delivered to enthusiastic DARPA consortium members in late 1990 and offered commercially shortly afterwards. It was a great boost to Cascade's already fine reputation as an innovation leader. Being the world's first commercial waveguide input wafer probe it was well publicized at the time and was followed up followed up by the W-band

wafer probe. This prompted GGB to introduce their own waveguide input probe in 1992.

In early 1993, I conceived of a new probe design consisting of a coplanar transmission line with no substrate (i.e., in air) attached to the end of a coaxial cable. By tapering the three conductors [ground-signal-ground (GSG)], they would be compliant enough to allow scrubbing when contacting a wafer. I called the design the air-coplanar probe (ACP), and it was based on converting the radial field of the coaxial to a CPW mode that then travelled to the probe tip along an impedance-controlled interconnect. This concept was novel and awarded a patent [S4].

The ACP development turned out to be very challenging since much of the tooling, manufacturing, and technology had to be developed. Scale models were constructed and measured to create impedance design guides for an ACP waveguide. The metallurgy for a flexible probe tip had to be developed along with a proprietary process to cut it to shape. My colleagues Jeff Williams and Jeremy Burr played key roles in this development, which spanned several months. The probe was introduced to the public by early 1994 [S2] and was well received. It was substantially more rugged than the old WPH probe and had much lower insertion loss. The probe tips could bend at least $25 \mu\text{m}$ relative to each other, allowing easy probing of nonplanar structures and eliminating the need for the fine-tuning of the WPH to get the tips absolutely planar with the wafer. The ACP became the primary probe sold by Cascade until they introduced the Infinity probe about a decade later.

—Ed Godshalk, Ph.D.,

*Distinguished Member of Technical Staff,
Maxim Integrated*

References

- [S1] E. M. Godshalk, "A V-band wafer probe using ridge-trough waveguide," *IEEE Trans. Microwave Theory Tech.*, vol. 39, no. 12, pp. 2218–2228, Dec. 1991.
- [S2] E. M. Godshalk, J. Burr, and J. Williams, "An air coplanar wafer probe," presented at the 43rd Automatic RF Techniques Group Conf., San Diego, CA, May 27, 1994.
- [S3] E. M. Godshalk, "Ridge-trough waveguide," U.S. Patent 4,992,762, Feb. 12, 1991.
- [S4] E. M. Godshalk, "High-frequency probe tip assembly," U.S. Patent 5,506,515, Apr. 3, 1996.

replaced without removing the probe body from the measurement station.

It is difficult to overestimate the contribution the WPH probes made to the development of microwave technology in 1980s and 1990s. But they did suffer from several technical limitations. The most critical limitation was a fragile ceramic CPW line. Even a minimal force applied above the recommended value (e.g., to achieve a better contact) damaged the probe. Many engineers called this moment

"the click of death." Indeed, the sound of a cracking ceramic blade indicated not only a broken probe, but it could also often push the whole project to the dead end since the probes were very expensive. This was especially the case for universities and small research laboratories.

Despite the introduction of the RTP series, the ceramic probes were eventually pushed out of the market by alternative technologies, as Figure 4 shows impressively.

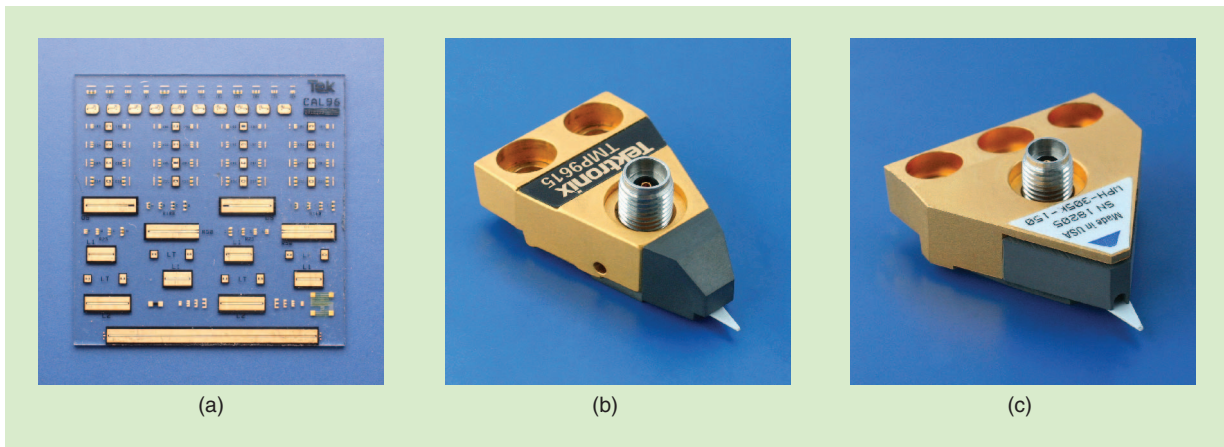

Figure 5. (a) The first commercially available sapphire calibration substrate CAL96, (b) the RF wafer probe TMP9600 from Tektronix, and (c) the WPH probe from Cascade Microtech. (Pictures courtesy of FBH.)

Picoprobe (GGB Industries)

The year 1988 was another milestone when GGB Industries filed a patent on RF probes based on a microcoaxial cable [27]. The use of the microcoaxial cable as an intermediate transition media has the following technical benefits:

- 1) Significant mechanical improvements extended the probe's lifespan.
- 2) Damaged probes could be retapped in a relatively easy and inexpensive way.
- 3) Electrical characteristics such as insertion loss were improved.
- 4) It simplified the manufacturing process.
- 5) Probes became less expensive.

The head-to-head run with Cascade Microtech had begun (Figure 7).

Just four years later, in 1993, GGB introduced a W-band probe at the IEEE Microwave Theory and Techniques Society International Microwave Symposium (IMS) [28]. In 1999, their probes achieved 220 GHz [29],

expanding further to 325 GHz in 2006 and 500 GHz in 2012 [30], [31]. Thanks to customer centricity and close cooperation with analytical probe system vendors, such as Karl Suss (later SUSS MicroTec), GGB Industries became one of the most influential players on the RF probe market worldwide.

ACP (Cascade Microtech)

In response to GGB's Picoprobe, Cascade presented the new 40-GHz air-coplanar probe (ACP) at the 43rd Spring ARFTG Conference in 1994 (Figure 8) [32]. Within a couple of years, ACP probes rapidly reached frequencies of 110 GHz (1-mm connector model) and 140 GHz (waveguide based model) replacing the WPH product line [33]. Up to now, many engineers favor ACPs for probing on gold pads due to their soft and nondestructive touch. Once again, "The Story of the Waveguide Input Wafer Probe and the Air Coplanar Wafer Probe" gives an interesting insight on how ACP probe came to life.

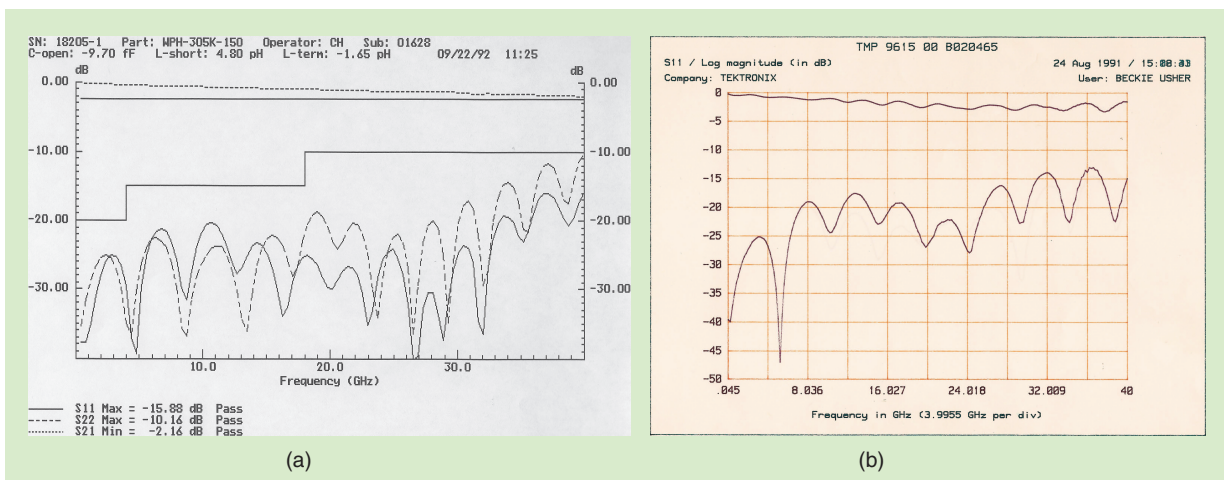

Figure 6. (a) The insertions and the return loss of the 40-GHz models of Tectronix TMP9615 probe, 1991, and (b) Cascade WPH-305K probe, 1992. (Pictures courtesy of FBH.)



Figure 7. The Picoprobe from GGB Industries. (Courtesy of FBH.)

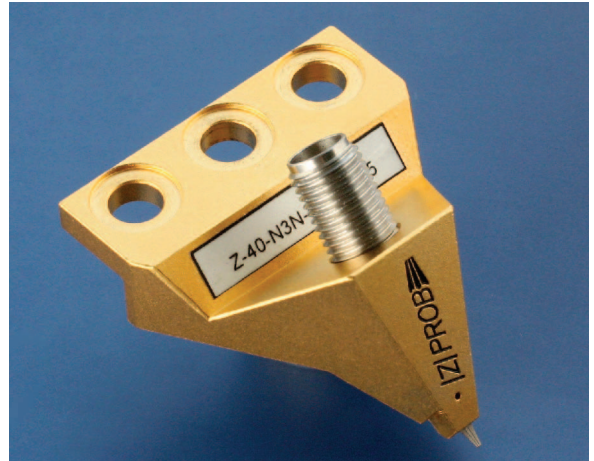

Figure 9. The first model of |Z|-Probe from SUSS-Rosenberger. (Courtesy of FBH.)

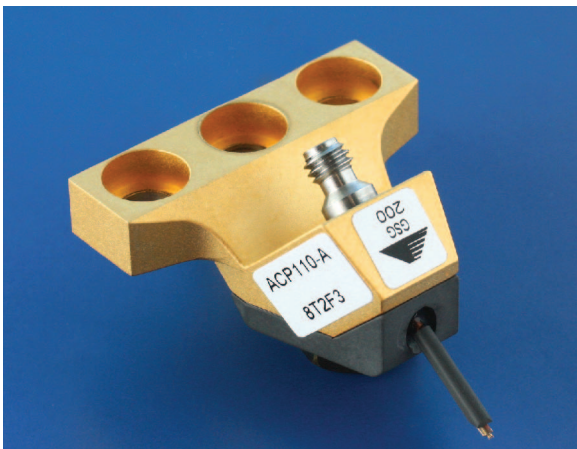

Figure 8. The ACP probe from Cascade Microtech. (Courtesy of FBH.)



Figure 10. The Infinity Probe from Cascade Microtech. (Courtesy of FBH.)

|Z|-Probe (Rosenberger-SUSS MicroTec)

In 2000, the community witnessed the appearance of a third player when Rosenberger introduced a novel concept of RF probes for PCB applications with a number of obvious advantages over conventional technologies [34]. Rosenberger established a fruitful partnership with Karl Süss KG (later SUSS MicroTec), scaled down the probe geometry to the wafer-level requirements, and introduced the new RF wafer probe |Z|-Probe as “a SUSS-Rosenberger Product” in 2001 [35]. The first |Z|-probe covered the 40 GHz range and realized several pioneering ideas.

- 1) The probe did not use a microcoaxial cable. Instead, it realized a direct transition from the coaxial connector to the air-isolated coplanar contact line.
- 2) This transition was made within the probe body, which allows a precise optimization of the transition point, minimizing possible discontinuities.
- 3) The coplanar contacts were fabricated using an ultraviolet lithography and electroplating process

(UV-LIGA) that is very similar to the one used for fabricating MEMS components. Extremely high accuracy and repeatability of the process provided very accurate shape of the CPW line and a constant air gap (Figure 9).

In summary, it became possible to increase the length of coplanar contacts to about 2 mm without sacrificing probe return loss because they were very well matched. The probe achieved unique mechanical characteristics, such as: incomparable lifespan of over 1 million touchdowns on aluminum (Al) contact pads, a maximum overtravel of 200 μm , and a probing of DUTs with a pad height difference of 50 μm [36].

In the mid-1990s, silicon became popular for commercial RF applications. It raised several challenges for RF probe manufacturers. Traditionally, RF probe contacts were made from beryllium-copper (BeCu). This material became troublesome when probing the Al contact pads of silicon devices and circuits. Quick oxidation and accumulation of dirt on the BeCu tips resulted in a drastic decrease of contact repeatability

on the Al pads. To tackle this problem, vendors offered RF probes with tungsten (W) tips [37]. Test engineers, who operated multipurpose measurement setups, were forced to change the probes each time when changing the DUT type (silicon or III-V compound semiconductors), even if the frequency range of test remained the same. The $|Z|$ -probe addressed this inconvenient situation as well. The coplanar contacts were made from nickel (Ni), demonstrating optimal contact performance on both Al as well as gold contact pads. Later on, other RF probe vendors started offering multipurpose probes with tips made from Ni or Ni alloys.

Infinity Probe (Cascade Microtech)

Following the increased demand for RF characterization of MOS and BiCMOS devices and the shrinking DUT pad size, Cascade Microtech introduced new wafer probes based on thin-film technology at the 59th Spring Automatic RF Techniques Group (ARFTG) Microwave Measurement Conference in 2002 (Figure 10) [38]. This method was based on Cascade's Pyramid Probe Card technology [39]. A microstrip line on a flexible polyimide membrane substrate transmitted the signal from the coaxial line to the DUT through nonoxidizing noble metal probe tips. The contact area of the Ni probe tips was approximately $12 \mu\text{m} \times 12 \mu\text{m}$ to allow probing very small pads.

The new Infinity Probe demonstrated superior contact consistency and very low probe-to-probe crosstalk. This technology became a benchmark for characterization of high-Q passives and for extraction of challenging parameters of small active MOS and BiCMOS devices, such as Mason's Gain [40].

Cascade offered Infinity Probe for 40, 50, 67, and 110 GHz frequencies. The waveguide-based probes for 220 and 325 GHz measurements were introduced in 2005 and 2007, respectively [41], [42]. There were several design iterations before Cascade started offering an Infinity Probe for the 500 GHz band in late 2009 as a custom product (e.g., [43]).

DMPI and Allstron Probes

In 2009-2011, two newcomers entered the well-established probing market: DMPI targeted with micromachined probes the emerging sub-THz market. See "Micromachined On-Wafer Probe Technology" by Prof. Scott Barker on how DMPI probes were developed.

On the other part of the globe, Allstron, Inc. from Taiwan offered inexpensive probes for applications below 110 GHz, where test costs reduction was one of the prime requirements (Figure 11). Probes from Allstron have a traditional design, based on a micro-coaxial cable. The contact structure is the air-isolated CPW line. It is similar to ACP, but the tip is shaped out for probing on Al pads with small passivation windows.

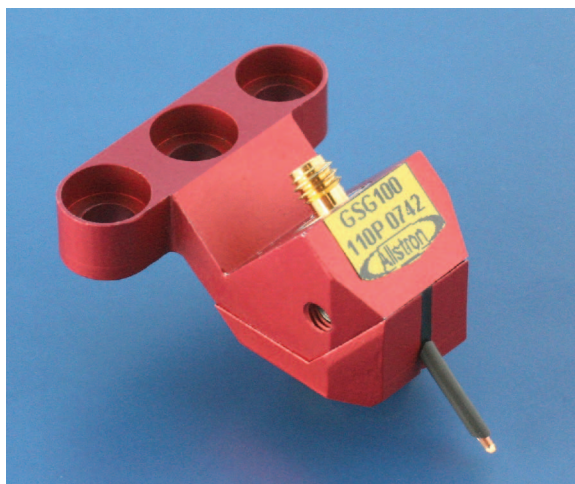

Figure 11. The RF probe from Allstron. (Courtesy of FBH.)

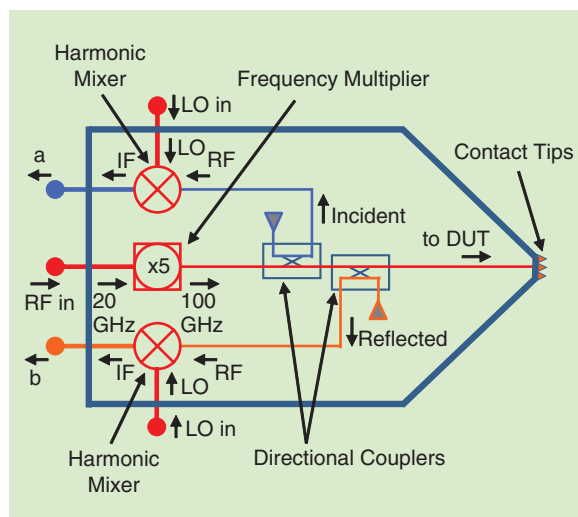

Figure 12. A schematic diagram of an active probe frequency extender.

Experiments with Alternative Concepts

Cascade and GGB had shared the RF probe market for almost ten years until 2001. At this time, there were several research projects evaluating alternative ways of building a wafer probe, yet, none of them ended up with a commercialized product. In the following, we give some examples.

A group of scientists from Electronic Laboratories of University of Kent (United Kingdom) and Cavendish Laboratories of University of Cambridge (United Kingdom) proposed a probe based on the dielectric waveguide and proved the concept for 140 GHz [44], [45].

Researchers from Stanford University (California, United States) investigated a concept of an active probe originally being developed for on-wafer S-parameter measurements of mm-wave ICs. The probe body integrated directional couplers, frequency converter and harmonic mixers that allow

Micromachined On-Wafer Probe Technology

Dominion MicroProbes, Inc. (DMPI) is a startup company located in Charlottesville, Virginia, that is licensing THz frequency microprobe technology from the University of Virginia (UVA). This technology was developed by the founders of DMPI who are also faculty at UVA: Prof. Barker, Prof. Lichtenberger, and Prof. Weikle, whose THz research is internationally recognized and have collective expertise in submillimeter-wave devices and circuits from design to fabrication to measurement and analysis.

The micromachined on-wafer probes were initially developed under a subcontract from Northrop Grumman Corporation (NGC) for the DARPA THz Electronics Program. The development of this technology was crucial to the success of this program in that it enabled rapid measurement of numerous devices without the need for packaging, greatly increasing the throughput of NGC's ability to test the InP transistors being developed.

The success of the micromachined wafer probe developed hinged on a collaboration between the three research groups at UVA, each bringing their unique expertise to bear on the tough problem of creating a wafer probe that was reliable, relatively low-loss up to 750 GHz (for Phase I of the program), and usable.

Prof. Lichtenberger's group had developed a unique fabrication process for realizing beam-leads using a silicon-on-insulator based process. Prof. Weikle's group had years of experience in developing E-plane split waveguide blocks with Schottky diode based MMICs for various applications including mixers, multipliers, and phase shifters. Prof. Barker's group had a strong background in radio-frequency microelectromechanical systems (RF-MEMS) and micromachining for millimeter-wave applications. Through an intense collaboration between these three groups, the initial W-band wafer probe prototype was attempted and proved

characterization of mm-wave ICs from 75GHz to 110 GHz band with the low-frequency vector network analyzer (Figure 12) [46].

A group from University of California, Santa Barbara (United States) applied nonlinear transmission lines for generating broadband stimulus, expanding the bandwidth of the active probe for 8 GHz to 96 GHz [47] and one year later for 7–120 GHz band with an impressive measurement repeatability of 0.2 dB [48].

The use of nonlinear transmission lines appeared to be a viable concept for building wideband active

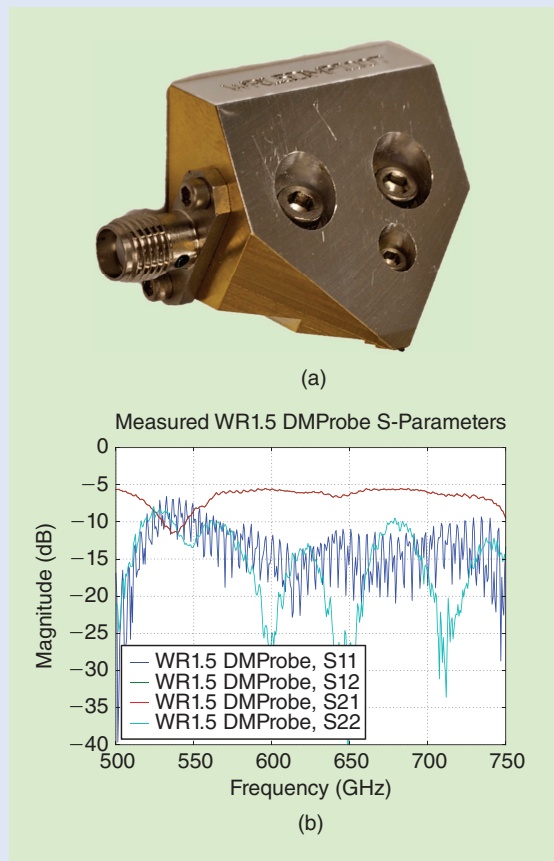

Figure S2. (a) DMPI wafer probe and (b) typical electrical characteristics of the 750 GHz DMPI probe. (Courtesy of DMPI.)

successful in 2010. Based upon this success, we filed for a provisional patent and plunged forward with immediately scaling this design up to WR1.5 (500–750 GHz), realizing the first prototype in 2010 and refining that design in 2011.

At this point, it became apparent that we had managed to develop a technology that had the

probes. Using this, Wohlgemuth, Reuter, and coworkers from the Fraunhofer Institute for Applied Solid State Physics (Freiberg, Germany) demonstrated a probe covering the frequency band from 70 GHz to 230 GHz in 1999 (Figure 13) [49].

Design of Modern Wafer Probes

A good overview of RF probe technologies was given in [50] and [51]. Here, we revise it with some new probes.

The RF wafer probe transforms the test signal from a three-dimensional media (coaxial cable or

potential to be successfully commercialized. During the summer of 2011, the three faculty (Barker, Lichtenberger, and Weikle) decided to move ahead with forming a company to commercialize the micromachined on-wafer probe technology and established DMPI. Fortunately, due to the excellent work done on developing the prototype probes, we were able to get the company up and running without the need for external investment, and so far we have maintained our independence.

In our view, there are several unique aspects to this probe design that are responsible for its success. The primary aspect is the use of silicon-on-insulator technology for realizing a single probe-chip design with precision metal patterning on both sides of the chip. This enables excellent control over both the RF and mechanical design of the probe. In addition, if you consider the modulus of resiliency—a material property that represents the ability to store strain energy without fracturing—silicon is one of the best materials available. This allows the greatest flexibility with respect to the codesign of the RF and mechanical properties. The use of silicon also enables batch fabrication of the probe chips, which helps drive down the cost as volumes increase. Finally, this probe design makes use of an important innovation that allows the silicon probe chip to be clamped into the split-block without the need for an adhesive (such as epoxy)—this allows the probe to be serviced relatively easily when the probe chip becomes worn out or damaged.

With the initial push of getting the company off the ground, we are now focusing on expanding this probe technology to lower and higher bands. To date, DMPI is offering on-wafer probes from 140 GHz up to 900 GHz (with measured data to back up these products) and is committed to developing a 1.1 THz (WR1.0) probe by the end of 2013.

—Prof. Scott Barker, DMPI

rectangular waveguide) to two-dimensional (coplanar) probe contacts. This operation requires careful treatment of the characteristic impedances Z_0 of transmission media and proper conversion of the electromagnetic (EM) energy between different propagation modes. While the input of a wafer probe is a standardized coaxial or waveguide interface, its output (the probe tip) realizes different design concepts. The interfaces, in particular the probe tip, bring discontinuities into the measurement signal path. As per [52], such discontinuity causes the generation of higher order propagation modes per se. Thus, wafer

probes and DUT launches must support only a single quasi-TEM propagation mode and should exclude higher-order modes or exhibit significantly higher impedance to them (e.g., [53]).

The conversion of the EM-field pattern is maintained by several RF transition steps within a single probe assembly. A conventional RF probe consists of the following parts:

- 1) test instrumentation interface (coaxial or waveguide)
- 2) transition from the test interface to the microcoaxial cable
- 3) transition from microcoaxial cable to a planar waveguide, such as CPW or microstrip
- 4) coplanar interface to a DUT on the wafer (or probe tip).

Several probes either combine steps 3) and 4) or do not use the microcoaxial cable (Figure 14). A coaxial connector is a commonly used test system interface of RF probes below 65 GHz. Both coaxial and waveguide connections are possible interfaces for the frequency range from 50 to 110 GHz. Broadband measurement systems covering a frequency range from dc to 110 GHz in a single sweep utilize the smallest size (1 mm)

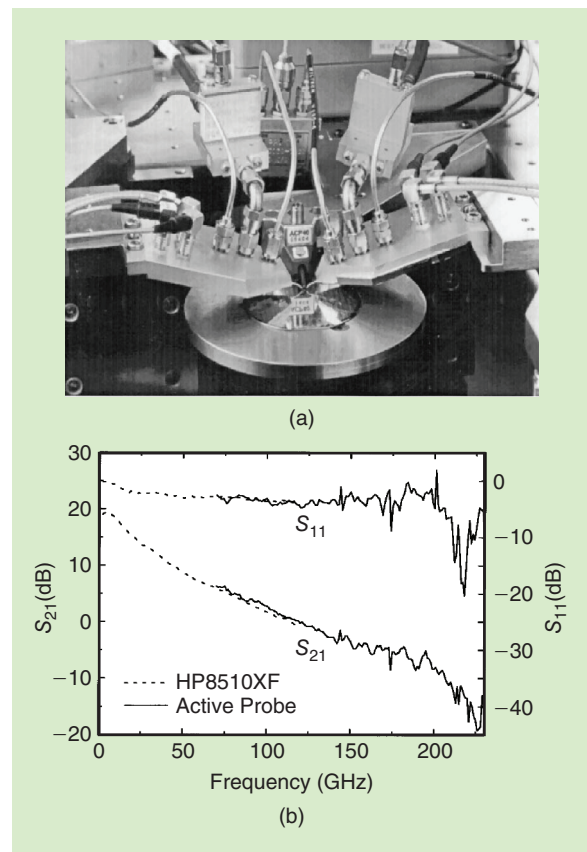

Figure 13. (a) The active probes mounted on a wafer probe station. (b) S_{11} and S_{21} of a pseudomorphic InAlAs/InGaAs HEMT measured with commercial passive probes up to 110 GHz and the active probes from 70 to 230 GHz. (Figure from [49].)

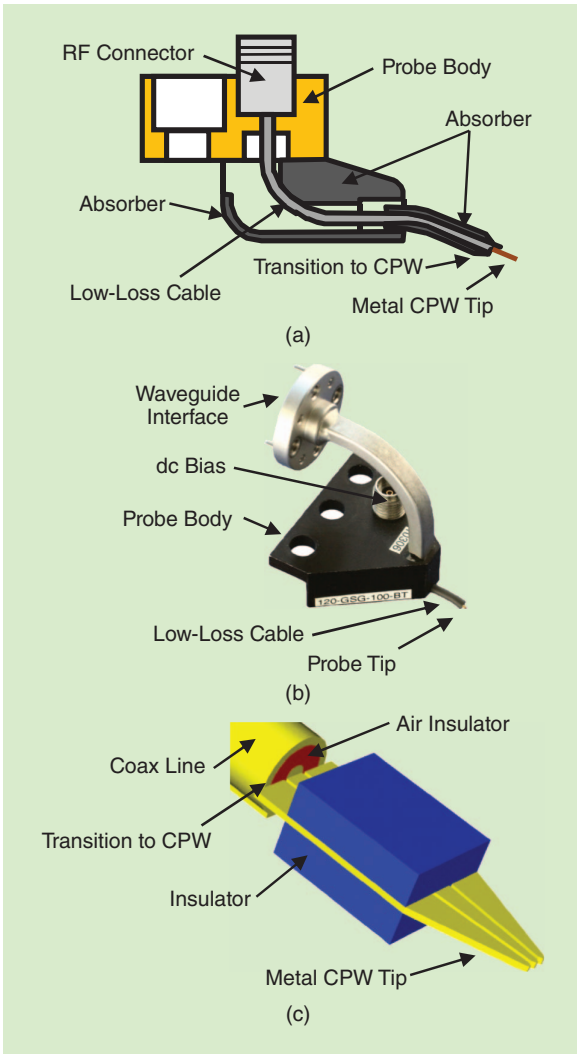

Figure 14. (a) A concept of an RF probe based on a microcoaxial cable for coaxial (GGB, ACP, Allstron), (b) waveguide (GGB, ACP, Infinity) interface, and (c) direct transition from the coaxial to the coplanar line ($|Z|$ -Probe). (Courtesy of FBH.)

coaxial connector [54]–[56]. Rectangular waveguides of different dimensions interface to the measurement system from above 110 GHz.

Recently, the 0.8-mm coaxial connector was introduced for a measurement system covering a band from 70 kHz to 145 GHz in a single sweep. The 0.8-mm connector-based RF probe is also underway [57].

At mm-wave frequencies, the rectangular waveguide TE_{10} EM fields can be converted into coplanar TEM-type EM fields either directly or in two steps. The two-step method applies a short section of a microcoaxial cable and is common for RF probes up to 325 GHz. The use of a microcoaxial cable is advantageous from the mechanical point of view. However, its relatively high insertion loss together with the impact of additional transition step reduces the overall probe electrical performance. The direct transition to a microstrip membrane tip [58] or to a micromachined silicon CPW [59] makes the microcoaxial cable dispensable.

There are several approaches for designing probe tips and attaching them to the rest of the probe. This variety arises from the tradeoff between mechanical and electrical requirements for probing on different contact pad materials (Figure 15).

- 1) The signal conductor of the microcoaxial cable is shaped out to form the signal tip. Ground blades of the tip are soldered from both sides of the cable (Picoprobe, GGB).
- 2) The air-isolated CPW tip is attached to the microcoaxial cable (ACP, Cascade Microtech and Allstron Probes).
- 3) The flexible polyamide microstrip line, which ends with the CPW tips, is attached to the microcoaxial cable (Infinity Probe, Cascade Microtech).
- 4) Direct transmission (without microcoaxial cable) from the coaxial connector to the air-isolated CPW contacts ($|Z|$ -Probe, Rosenberger-Cascade Microtech).

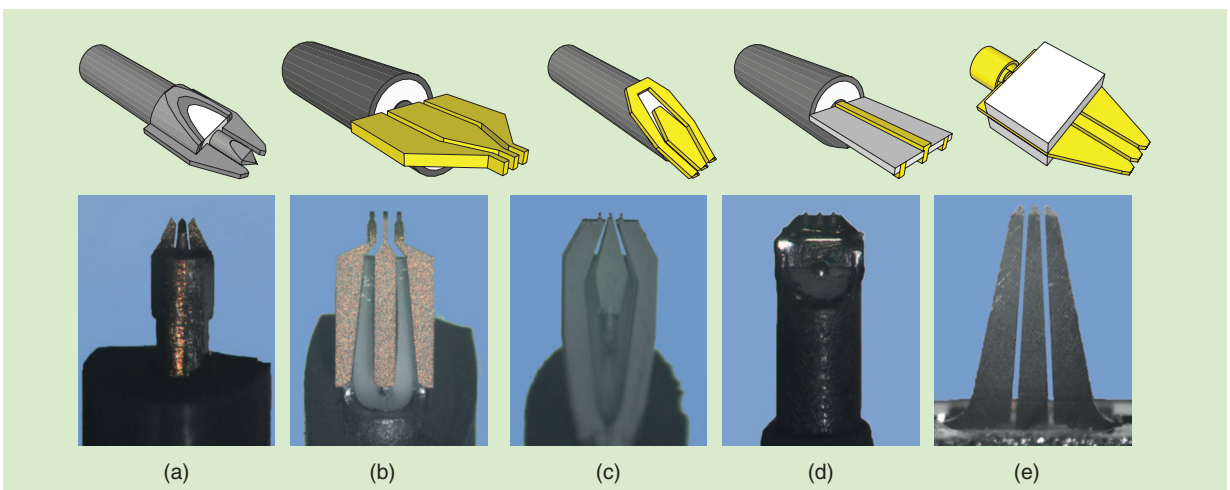

Figure 15. Technology of the GSG probe tip: (a) Picoprobe (top view, 100- μm pitch), (b) ACP (125- μm pitch), (c) Allstron (100- μm pitch), (d) Infinity Probe (125- μm pitch; all bottom view), and (e) $|Z|$ Probe (125- μm pitch). (Pictures courtesy of FBH.)

- 5) Direct transmission from the rectangular waveguide to a polyamide microstrip line (500 GHz Infinity Probe, Cascade Microtech).
- 6) Direct transition from the rectangular waveguide to a micromachined silicon CPW contact structure (DMPI) (Figure 16).

The interfaces, in particular the probe tip, bring discontinuities into the measurement signal path. Such discontinuity causes the generation of higher-order propagation modes per se. Thus, wafer probes and DUT launches have to support only a single quasi-TEM propagation mode and should exclude higher-order modes or exhibit significantly higher impedance to them. We will come back to this topic in the next article of this series, where we will demonstrate the impact of the probe tip design on the calibration residual errors and the measurement accuracy.

There are several configurations of the probe tips: ground-signal (GS), GS-ground (GSG) for single-ended measurements, as well as various combinations of signal and ground contacts for dual/differential measurements (such as GSGSG, GSSG, SGS, etc.). Moreover, comprehensive mixed-signal wafer probes were developed to address the challenges of measuring complex integrated circuits. Typically, their RF signal transition technique resembles conventional probes. Such probes use multiple RF channels in on probe body and dc channels for biasing and IC control. As custom products, they are optimized to the pad layout of the IC to be tested.

Conclusions

In this article we presented an overview of the history of the RF probe technology. Working in our archives and carrying out research in electronic archives of the IEEE, we came up to an unexpected conclusion about the early days of RF probing. In fact, the competitive situation has been always present in the RF probe market. In the 1980s, engineers had a choice between TPM9600 probes from Tektronix and WPH probes from Cascade. In our opinion, it wasn't a competition of the probe technologies, as both probe series were very similar to each other. Rather, it was a competition of customer service and product lines. Obviously, Cascade Microtech had a significant advantage as it had been offering complete probing solutions (including wafer probe stations) from the first day on [18].

The situation changed when GGB Industries joined the game. To the engineers' benefits, probing technologies started competing with each other on multiple fields, such as measurement accuracy, mechanical characteristics, possibility to retip a broken probe, and, last but not least, the price.

We identified a natural probe technology life cycle of about 12 years. Two main factors drive the development of the probing technology: 1) improvement of measurement accuracy for high-end applications and 2)

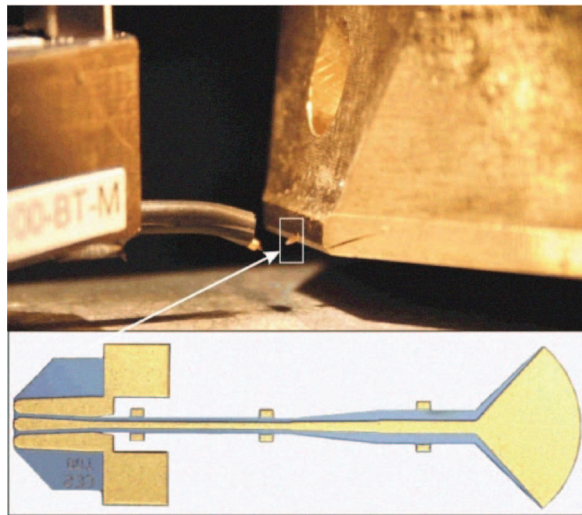

Figure 16. GSG probe tip of the DMPI probe (from [59]).

cost reduction of test for mainstream applications. Besides the already discussed new probes vendors for the mainstream (Allstron) and high-end (DMPI) applications, we came across some newcomers offering products for low-frequency (GigaTest Labs [60], and Techno Probe Co. Ltd.) and for wide frequency range (Yokowo Co, Ltd. [61]).

In our next article within this series we will review the wafer-level calibration as well as some measurement challenges and pitfalls.

References

- [1] E. Strid, "A history of microwave wafer probing," in *50th ARFTG Microwave Measurements Conf. Dig.-Fall, 1997*, pp. 27–34.
- [2] E. Strid, D. Dunn, M. Shakouri, D. Williams, and M. Golio, "On-wafer testing issues for the 90's and beyond," in *38th ARFTG Conf. Dig.-Winter, San Diego, CA, 1991*, pp. 139–169.
- [3] Data Sheet, *Multi-Contact Wedge*, GGB Industries Inc., Naples, FL, 2002.
- [4] Technical Brief, *Addressing the Challenges of Small Pad Probing*, Cascade Microtech Inc., Beaverton, OR, 2012.
- [5] Z. D. Schwartz, A. N. Downey, S. A. Alterovitz, and G. E. Ponchak, "High-temperature RF probe station for device characterization through 500 °C and 50 GHz," *IEEE Trans. Instrum. Meas.*, vol. 54, no. 1, pp. 369–376, 2005.
- [6] H. Geissler, A. Rumiantsev, S. Schott, P. Sakalas, and M. Schroter, "A novel probe station for helium temperature on-wafer measurements," in *Proc. 68th ARFTG Microwave Measurements Conf.-Fall, 2006*, pp. 67–73.
- [7] *Microwave Measurements with Lake Shore Probe Stations*, Lake Shore Cryogenics Inc., Application Note, Westerville, OH, 2007.
- [8] T. Vaha-Heikkila, J. Varis, H. Hakojarvi, and J. Tuovinen, "Wideband cryogenic on-wafer measurements at 20–295 K and 50–110 GHz," in *Proc. 33rd European Microwave Conf.*, 2003, pp. 1167–1170.
- [9] Specification Sheet *ZProbePower-SS-0310*, |Z| Probe Power High-Frequency RF Probe, Cascade Microtech Inc., Beaverton, OR, 2010.
- [10] L. Chen, C. Zhang, T. J. Reck, C. Groppil, A. Arsenovic, A. Lichtenberger, R. M. Weikle, and N. S. Barker, "Terahertz micromachined on-wafer probes: Repeatability and robustness," in *IEEE MTT-S Int. Microwave Symp. Dig.*, 2011, pp. 1–4.
- [11] D. F. Williams, A. C. Young, and M. Urteaga, "A prescription for sub-millimeter-wave transistor characterization," *IEEE Trans. Terahertz Sci. Technol.*, vol. 3, no. 4, pp. 433–439, 2013.

- [12] R. V. Tuyl, C. Liechti, R. Lee, and E. Gowen, "4-GHz frequency deviation with GaAs MESFET ICs," in *IEEE Int. Solid-State Circuits Conf. Dig. Tech. Papers*, Philadelphia, PA, 1977, pp. 198–199.
- [13] E. Strid and K. R. Gleason, "A microstrip probe for microwave measurements on GaAs FET and IC wafers," presented at the IEEE Gallium Arsenide Integrated Circuit Symp., Las Vegas, NV, 1980, Paper 31.
- [14] E. W. Strid and K. R. Gleason, "A dc-12 GHz monolithic GaAsFET distributed amplifier," *IEEE Trans. Electron Devices*, vol. 29, no. 7, pp. 1065–1071, 1982.
- [15] L. R. Lockwood, K. R. Gleason, and E. W. Strid, "Wafer probe," U.S. Patent 4 697 143, Sept. 29, 1987.
- [16] 26W-7064 TEK CAL96 Calibration Substrate. Specifications, Ordering Information, CAL96 Calibration Substrate, Tektronix Inc., Beaverton, OR, 1989.
- [17] 47W-7833-1 TEK TMP9600 Series. Specifications, Ordering Information, TMP9600 Series Microwave Probes-DC to 40 GHz, Tektronix Inc., Beaverton, OR, 1990.
- [18] *Introducing the World's First Microwave Wafer Probing Equipment, Corporate Brochure*, Cascade Microtech, Beaverton, OR, 1983.
- [19] D. E. Carlton, K. R. Gleason, and E. W. Strid, "Microwave wafer probing achieves on-wafer measurements through 18 GHz," *Microwave Syst. News Commun. Technol.*, vol. 15, no. 5, pp. 99–115, 1985.
- [20] *On-Wafer Measurements Using the HP8510 Network Analyzer and Cascade Microtech Wafer Probes*, Hewlett Packard, Palo Alto, CA, 1986.
- [21] K. R. Gleason, T. M. Reeder, and E. W. Strid, "Precise MMIC parameters yielded by 18 GHz wafer probe," *Microwave Syst. News*, vol. 26, no. 5, pp. 55–65, 1983.
- [22] E. Strid, "26 GHz wafer probing for MMIC development and manufacture," *Microwave J.*, vol. 29, pp. 71–82, Aug. 1986.
- [23] K. E. Jones, E. W. Strid, and K. R. Gleason, "mm-wave wafer probes span 0 to 50 GHz," *Microwave J.*, vol. 30, pp. 177–183, Apr. 1987.
- [24] E. M. Godshalk, "A V-band wafer probe using ridge-trough waveguide," *IEEE Trans. Microwave Theory Tech.*, vol. 39, no. 12, pp. 2218–2228, Dec. 1991.
- [25] E. M. Godshalk, "Wafer probing at W-band," in *Proc. 23rd European Microwave Conf.*, 1993, pp. 848–850.
- [26] *Manufacturing Economies Provided by Replaceable-Tip Microwave Probes*, Cascade Microtech MicroProbe, Beaverton, OR, Oct. 1988.
- [27] G. Boll and H. Boll, "Integrated circuit probing apparatus," U. S. Patent 4 871 964, Oct. 3, 1989.
- [28] S. M. J. Liu and G. G. Boll, "A new probe for W-band on-wafer measurements," in *IEEE MTT-S Int. Microwave Symp. Dig.*, 1993, vol. 3, pp. 1335–1338.
- [29] T. Gaier, L. Samoska, C. Oleson, and G. Boll, "On-wafer testing of circuits through 220 GHz," in *Proc. Ultrafast Optics Electronics Conf.*, Snowmass, CO, 1999, pp. 20–26.
- [30] A. K. Fung, D. Dawson, L. Samoska, K. Lee, C. Oleson, and G. Boll, "On-wafer vector network analyzer measurements in the 220–325 GHz frequency band," in *IEEE MTT-S Int. Microwave Symp. Dig.*, 2006, pp. 1931–1934.
- [31] A. Fung, L. Samoska, D. Pukala, D. Dawson, P. Kangaslahti, M. Varonen, T. Gaier, C. Lawrence, G. Boll, R. Lai, and X. B. Mei, "On-wafer S-parameter measurements in the 325–508 GHz band," *IEEE Trans. Terahertz Sci. Technol.*, vol. 2, no. 2, pp. 186–192, Mar. 2012.
- [32] E. M. Godshalk, J. Burr, and J. Williams, "An air coplanar wafer probe," in *43rd ARFTG Conference Dig.-Spring*, 1994, pp. 70–75.
- [33] *Agilent 8510 System Solutions 5965-8837E*, Agilent Technologies, Inc., Santa Rosa, CA, 2000.
- [34] M. Wollitzer, B. Rosenberger, and W. Strasser, "Novel concept for a modular millimeterwave probe tip," in *55th ARFTG Microwave Measurements Conf. Dig.-Spring*, 2000, pp. 1–3.
- [35] M. Wollitzer, S. Thies, and S. Schott, "New probing technology now enables impedance controlled on-wafer probing," in *Proc. 31st European Microwave Conf.*, 2001, pp. 1–4.
- [36] |Z| Probe Technical Specification, SUSS MicroTec, Sacka, Germany, 2009.
- [37] J. L. Carbonero, G. Morin, and B. Cabon, "Comparison between beryllium-copper and tungsten high frequency air coplanar probes," *IEEE Trans. Microwave Theory Tech.*, vol. 43, no. 12, pp. 2786–2793, 1995.
- [38] A. M. E. SafWat, M. Andrews, L. Hayden, K. R. Gleason, and E. Strid, "A probe technology for 110+ GHz integrated circuits with aluminum pads," in *59th ARFTG Microwave Measurements Conf. Dig.-Spring*, 2002, pp. 60–66.
- [39] K. Smith, D. Gahagan, and L. Hayden, "Probe cards test high-speed, multifunctional ICs," *Microw. RF*, vol. 36, pp. 113–121, Jan. 1997.
- [40] *The Infinity Probe for On-Wafer Device Characterization and Modeling to 110 GHz, Infinity-QA-1102*, Cascade Microtech, Beaverton, OR, 2002.
- [41] R. L. Campbell, M. Andrews, T. Leshner, and C. Wai, "220 GHz wafer probe membrane tips and waveguide-to-coax transitions," in *Proc. Microwave Conf. European*, 2005, p. 4.
- [42] R. Campbell, M. Andrews, L. Samoska, and A. Fung, "Membrane tip probes for on-wafer measurements in the 220 to 325 GHz band," in *Proc. 18th Int. Symp. Space Terahertz Technology*, Pasadena, CA, 2007, pp. 141–149.
- [43] A. Tessmann, A. Leuther, V. Hurm, I. Kallfass, H. Massler, M. Kuri, M. Riessle, M. Zink, R. Loesch, M. Seelmann-Eggebert, M. Schlechtweg, and O. Ambacher, "Metamorphic HEMT MMICs and modules operating between 300 and 500 GHz," *IEEE J. Solid-State Circuits*, vol. 46, no. 10, pp. 2193–2202, 2011.
- [44] I. M. Boese, R. J. Collier, A. K. Jastrzebski, H. Ahmed, J. R. Cleaver, and D. Hasko, "An on wafer probe for measurements at 140 GHz," in *IEE Colloq. Terahertz Technology Applications* (Dig. No: 1997/151), London, 1997, pp. 9/1–9/7.
- [45] I. M. Boese and R. J. Collier, "Measurements on millimetre wave circuits at 140 GHz," *IEE Proc. Sci. Meas. Technol.*, vol. 145, no. 4, pp. 171–176, 1998.
- [46] R. Majidi-Ahy, M. Shakouri, and D. M. Bloom, "100 GHz active electronic probe for on-wafer S-parameter measurements," *Electron. Lett.*, vol. 25, no. 13, pp. 828–830, 1989.
- [47] R. Y. Yu, J. Pusi, Y. Konishi, M. Case, M. Kamegawa, and M. Rodwell, "8–96 GHz on-wafer network analysis," in *14th Annu. IEEE, Gallium Arsenide Integrated Circuit Symp. Tech. Dig.*, 1992, pp. 75–77.
- [48] R. Yu, M. Reddy, J. Pusi, S. Allen, M. Case, and M. Rodwell, "Full two-port on-wafer vector network analysis to 120 GHz using active probes," in *IEEE MTT-S Int. Microwave Symp. Dig.*, 1993, pp. 1339–1342.
- [49] O. Wohlgenuth, M. J. W. Rodwell, R. Reuter, J. Braunstein, and M. Schlechtweg, "Active probes for network analysis within 70–230 GHz," *IEEE Trans. Microwave Theory Tech.*, vol. 47, no. 12, pp. 2591–2598, 1999.
- [50] S. A. Wartenberg, *RF Measurements of Die and Packages*. Norwood, MA: Artech House, 2002.
- [51] S. A. Wartenberg, "Selected topics in RF coplanar probing," *IEEE Trans. Microwave Theory Tech.*, vol. 51, no. 4, pp. 1413–1421, 2003.
- [52] R. B. Marks and D. F. Williams, "A general waveguide circuit theory," *J. Res. Natl. Inst. Stand. Technol.*, vol. 97, pp. 533–562, Sept.–Oct. 1992.
- [53] W. Wiatr, D. K. Walker, and D. F. Williams, "Coplanar-waveguide-to-microstrip transition model," in *IEEE MTT-S Int. Microwave Symp. Dig.*, 2000, pp. 1797–1800.
- [54] "Agilent PNA microwave network analyzers," in *Product Brochure 5989-7604EN*. Santa Clara, CA: Agilent Technologies Inc., 2009, p. 16.
- [55] "R&S ZVA vector network analyzer. High performance up to 110 GHz with up to four test ports," in *Product Brochure PD 5213.5680.12 81671*. München, Germany: Rohde and Schwarz GmbH and Co. KG, 2011, p. 28.
- [56] "MS4640A series. Family of RF to microwave and millimeterwave vector network analyzers," in *Product Brochure 11410-00435 5-1-1 Onna*. Atsugi-shi, Kanagawa, 243-8555 Japan: Anritsu Company, 2009, p. 24.
- [57] J. Martens, T. Roberts, K. Noujeim, and S. Reyes, "70 kHz-145 GHz broadband S-parameter measurements: Calibration and verification possibilities," in *Proc. Asia-Pacific Microwave Conf.*, Kaohsiung, Taiwan, 2012, pp. 433–435.
- [58] A. Lord, "Advanced waveguide probe technologies for mm-wave and terahertz probing," in *Proc. European Microwave Week Agilent Technologies Workshop*, Amsterdam, The Netherlands, 2012, pp. 1–37.
- [59] T. J. Reck, C. Lihan, Z. Chunhu, A. Arsenovic, C. Groppi, A. Lichtenberger, R. M. Weikle, and N. S. Barker, "Micromachined on-wafer probes," in *IEEE MTT-S Int. Microwave Symp. Dig.*, 2010, pp. 65–68.
- [60] *GigaTest Labs Microwave Probes, Product Brochure*, GigaTest Labs Inc., Sunnyvale, CA, 2010.
- [61] *RF Probe-Test Solution Up to EHF, Product Brochure*, Yokowo Co. Ltd., Tokyo, Japan, 2012.

