

# INSTRUCTION MANUAL



## **LOG ADAPTER FOR OPERATIONAL AMPLIFIERS**

Copyright© 1963, new material copyright 1965 by Tektronix, Inc., Beaverton, Oregon. Printed in the United States of America. All rights reserved. Contents of this publication may not be reproduced in any form without permission of the copyright owner.

# GENERAL INFORMATION

## INTRODUCTION

The Log Adapter is a logarithmic feedback network that converts the Channel 1 or 2 (A or B) operational amplifier in a Tektronix Operational Amplifier Plug-In Unit from a linear to an essentially logarithmic amplifier. It is fitted with banana plugs so it can be plugged directly into the jacks provided on the front panel of the Operational Amplifier unit. The circuit configuration and operation of the device is similar to that given in the Operational Amplifier instruction manual.

## CHARACTERISTICS

### Input Resistance

Approximately 10 kilohms

### Operating Range

$\pm 0.1$  volt to  $\pm 100$  volts

### Maximum Input Signal

$\pm 100$  volts peak, ac- or dc-coupled

### Input Voltage vs Oscilloscope Vertical Deflection

An essentially logarithmic relationship for signals between  $\pm 0.1$  volt and  $\pm 100$  volts. System is not logarithmic for signals between about  $-0.05$  and  $+0.05$  volt.

Any convenient vertical deflection factor per input voltage decade can be used. (One cm/decade is used in the following example of input and display relationship.)

Dc-Coupled Input Signal (dc plus peak ac)	Deflection (from zero reference)
+0.1 volt	+1 cm, $\pm 0.5$ mm
-0.1 volt	-1 cm, $\pm 0.5$ mm
+1.0 volt	+2 cm, $\pm 0.5$ mm
-1.0 volt	-2 cm, $\pm 0.5$ mm
+10.0 volts	+3 cm, $\pm 1.0$ mm
-10.0 volts	-3 cm, $\pm 1.0$ mm
+100.0 volts	+4 cm, $\pm 1.0$ mm
-100.0 volts	-4 cm, $\pm 1.0$ mm

In the foregoing example, a 1-centimeter change in display peak deflection equals approximately a 20-dB change in input peak voltage (2 dB/mm).

## NOTE

Amplitude must be measured with respect to the zero-volt dc input trace position. When one peak of a dc-coupled signal is at zero volts, the peak-to-peak deflection amplitude can be used to calculate the peak-to-peak signal voltage. However, when neither display peak is at the zero-volt trace position, the peak voltages must be calculated separately. (This will usually be the case when ac coupling is used.) The sum of difference of the peak voltages will then indicate the peak-to-peak voltage of the ac portion of an input signal. See Fig. 1.

### Response Time

Depends upon the direction and the amount of change. For a 10-volt step input (either + or -), the time required for the amplifier output to rise from the 0.1-volt level to the 10-volt level is typically 0.2  $\mu$ second, and to fall from the 10-volt level to the 0.1-volt level it is typically 0.3  $\mu$ second. Response times for this and other peak voltages depend upon proper adjustment of the HF ADJ control for the particular peak signal voltage involved.

### Low-Frequency Response (Ac-coupled input)

30% down at about 70 hertz for signals over 500 mV peak amplitude with a signal source impedance of 50 ohms. (Low-frequency response is measured in a manner similar to that described in Apparent Bandwidth.)

### Input to Output Voltage Relationship

$$e_o = k_1 + k_2 \log_{10} e_i$$

Where:

$e_o$  = Operational Amplifier output voltage

$e_i$  = Log Adapter input voltage

$k_1 = e_o$  when  $e_i = 1$  volt (typically,  $k_2 = 0.15$  to  $0.2$ )

$k_1$  and  $k_2$  must be determined experimentally for a particular Log Adapter.

### Apparent Bandwidth

Sine-wave bandwidth measurements generally are not directly applicable to devices having a nonlinear output, since the rms and peak bandwidths differ. However, the apparent bandwidth data given here does provide a means of verifying proper performance of the Log Adapter/Operational Amplifier system.

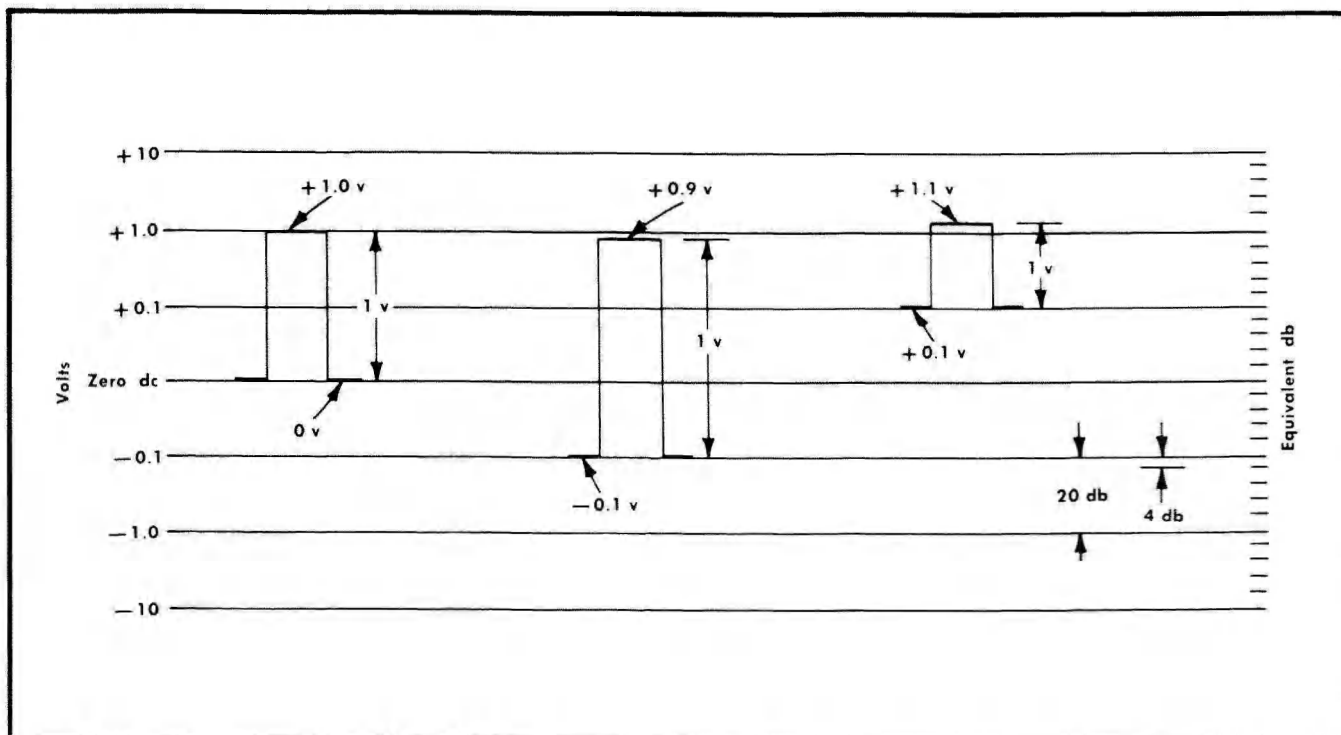

Fig. 1. Display amplitudes resulting from equal peak-to-peak signal voltages, but different dc levels.

Apparent bandwidth is measured using a constant-amplitude sine-wave generator with low output impedance and signal that is symmetrical about zero volts dc. Under these conditions, the apparent  $-3$  dB bandwidth is defined as that approximate upper frequency at which the output from the logarithmic amplifier drops to the same peak voltage as would be obtained with a 30% reduction in input signal amplitude at lower frequencies.

Typical apparent bandwidth figures are:

Signal Amplitude	Apparent Bandwidth	
	$-3$ dB	$-10$ dB
100 mV peak (200 mV p-p)	400 kHz	750 kHz
1.0 V peak (2.0 V p-p)	700 kHz	1.1 MHz
2.5 V peak (5.0 V p-p)	700 kHz	1.1 MHz
5.0 V peak (10.0 V p-p)	1.1 MHz	2.0 MHz

### PERFORMANCE CHECK AND CALIBRATION PROCEDURE

The Log Adapter has been carefully checked and adjusted prior to shipment. This functional check of all external controls and adjustments will assure the measurement accuracy and quality of the instrument. This performance check may be used for incoming inspection, quality assurance, reliability testing, instrument familiarization or for calibration of the unit.

### Recommended Equipment

1—Test oscilloscope. Tektronix 530, 540, 550, 560 (or 580-Series with 81 Plug-In Adapter) and an Operational Amplifier Plug-In Unit.

1—Constant-Amplitude sine-wave generator; frequency of 50 kHz and 0.35 to 1.7 MHz with an output amplitude of 5 volts peak to peak. Tektronix Type 190B or equivalent.

1—Square-Wave signal generator; frequency of 25 kHz, a risetime of less than 13 ns into terminated 50  $\Omega$  coaxial cable and an output signal voltage of at least 100 volts. Tektronix Type 105 or equivalent.

1—Variable dc voltage power source. Output voltage must be constantly variable from  $\pm 0.1$  to  $\pm 100$  volts. The power source must also be able to provide at least 15 mA of current to the load.

1—Accurate dc voltmeter to measure the output voltage of the variable dc power source.

1—Accurate ohmmeter. Used to measure the input resistance.

1—50  $\Omega$  coaxial cable 42 inches long with BNC connectors. Tektronix Part No. 012-0057-00.

1—50  $\Omega$  termination with BNC connectors. Tektronix Part No. 011-0049-00.

1—Patch cord 18 inches long with a BNC and a banana plug. Tektronix Part No. 012-0090-00 or 012-0091-00.

Adjust the output signal amplitude of the Type 105 until a maximum amplitude display is viewed on the test oscilloscope.

Change the Time Base Time/cm control to 10  $\mu$ Sec and adjust the Level control for a stable display.

Adjust the HF ADJ for minimum spike at the bottom leading edge of the waveform.

Change the signal output amplitude of the Type 105 until a 3 cm high display is obtained.

Set the Time Base Slope switch to — and adjust the Level control for a stable display with a negative-going leading edge.

NOTE

Since the Type 105 produces a negative-going square-wave, the top of the waveform displayed on the test oscilloscope is approximately at ground potential. Therefore, with the controls set as indicated above, the risetime of the waveform will be measured.

Change the Time Base Time/cm control to .2  $\mu$ Sec. Position the waveform to the center of the lower graticule area and measure the risetime from the 0.1 V point (1 cm below the top of the waveform) to the 10 V point (the bottom of the waveform) (Fig. 2a). The risetime from 0.1 V to 10 V should be typically 0.2  $\mu$ seconds.

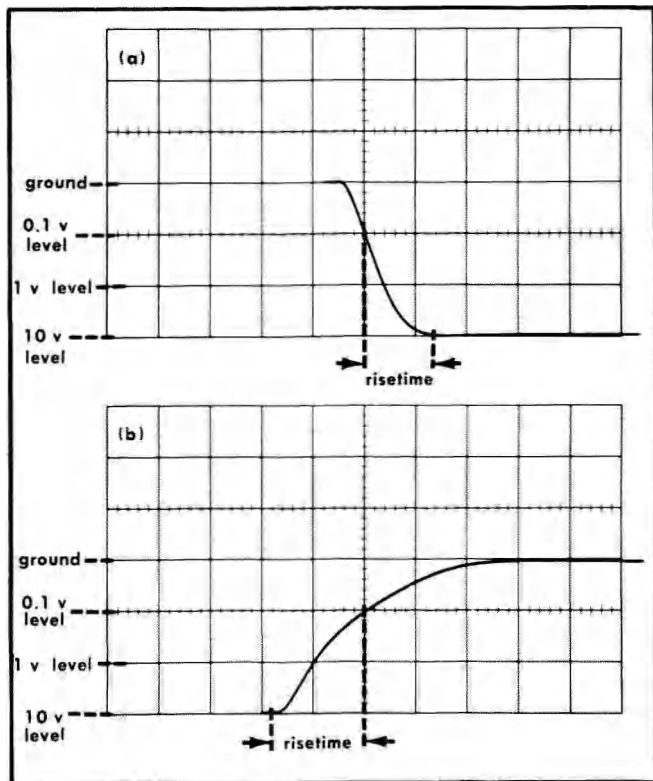

Fig. 2. Apparent response time. (a) Risetime measurement and (b) falltime measurement.

Set the Time Base Slope switch to + and adjust the Level control for a stable display with a positive-going leading edge.

Position the waveform to the center of the lower graticule area and measure the falltime from the 10 V point (the bottom of the waveform) to the 0.1 V point (1 cm below the top of the waveform), see Fig. 2b. The falltime should be typically 0.3  $\mu$ seconds.

Disconnect the 50  $\Omega$  coaxial cable, 50  $\Omega$  termination and the Type 105.

4. AC Coupled Low-Frequency Response

Response is 70 hertz or less at the —30% point for signals larger than 500 mV peak amplitude.

Set the Log Adapter AC-DC switch to AC, the Operational Amplifier Volts/Cm switch to .1 and the Time Base Time/cm switch to 10 mSec.

Connect a patch cord from the Time Base +Gate connector to the INPUT connector on the Log Adapter.

Adjust the Operational Amplifier Variable control until a display amplitude of 4 cm is obtained.

Position the display to the center of the graticule area, then measure the time it takes the rc waveform to fall from the 4 cm point to the 2 cm point (see Fig. 3). The 2 cm point should be more than 2.5 mseconds (less than 70 hertz).

Remove the patch cord.

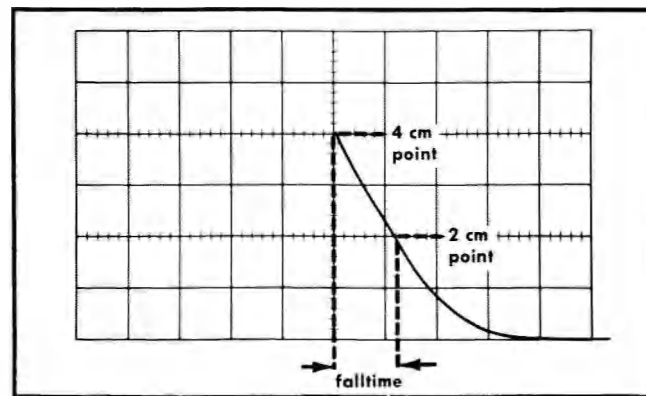

Fig. 3. Measuring AC coupled low frequency response using an RC curve.

5. Apparent Bandwidth

This step checks the apparent bandwidth measurement for the Log Adapter. See the following table for the bandwidth figures on both the AC and DC switch positions.

## Log Adapter

All equipment listed is assumed to be calibrated and to perform within its specifications. If there is any doubt, it should be calibrated before performing this check. If recommended equipment is not available, equivalent test equipment may be substituted. The user must determine proper settings for the substitute equipment.

Words with first letter or complete name capitalized refer to front- or rear-panel control labels and Tektronix instrument names.

## Preliminary

Plug the Log Adapter into the Operational Amplifier banana jacks and the Operational Amplifier Plug-In Unit into the test oscilloscope plug-in compartment. Apply power and allow all test equipment to warm up for 15 minutes before proceeding with the performance check. Reset the front-panel controls as follows:

Log Adapter	
AC-DC	DC
Operational Amplifier	
Vertical Display	—2 (—B)
Position	Midrange
Volts/Cm	.2
Variable	Calibrated
Channel 1 and 2 (A and B) Operational Amplifiers $\pm$ Grid Sel	—
Integrator LF Reject	Off
Z <sub>i</sub>	Ext
Z <sub>r</sub>	Ext
Oscilloscope	
Amplitude Calibrator	Off
Scale Illum	As desired
Focus	Adjusted for best display
Intensity	Adjusted for usable display brightness
Horizontal Position	Midrange
Horizontal Display	$\times 1$
Time Base Unit	
Level	Clockwise
Vernier	Clockwise
Slope	+
Coupling	AC
Sweep Function	Auto
Time/cm	.5 mSec
Variable	Calibrated

### NOTE

Do not change these settings until directed in the procedure.

## Procedure

### 1. Input Resistance

Measurement of input resistance. The resistance should be approximately 10 kilohms.

Set the scale switch on the ohmmeter to a scale which will provide a 10 kilohm reading near the midscale point of the ohmmeter. Connect the ohmmeter leads together and adjust the zero ohm adjustment for a reading of zero ohms.

Connect one of the leads from the ohmmeter to the center conductor of the INPUT connector of the Log Adapter and the second lead of the ohmmeter to the outer conductor of the INPUT connector.

Note the ohmmeter reading. It should be approximately 10 kilohms.

Disconnect the ohmmeter.

### 2. Operating Range

Adjust the 100 V CAL and check the accuracy of the Log Adapter over the signal voltage range from  $\pm 0.1$  to +100 volts.

After sufficient warm-up period, check the DC Balance of the Operational Amplifier, and position the trace to the center horizontal graticule line.

Connect the variable dc voltage power source to the INPUT connector of the Log Adapter. Apply a negative 100 volt-dc signal from the power source of the Log Adapter and adjust the 100 V CAL for exactly 4 cm of downward deflection.

Apply the negative dc voltage listed below and check for the amount of downward deflection listed below.

Applied dc voltage	Amount of Deflection
0.1	1 cm $\pm 0.5$ mm
1	2 cm $\pm 0.5$ mm
10	3 cm $\pm 1$ mm
100	4 cm $\pm 1$ mm

Position the trace to the bottom horizontal graticule line. Apply the positive dc voltages listed above and check the amount of upward deflection listed above.

Disconnect the variable dc voltage power source.

### 3. Apparent Response Time

Adjust the HF ADJ and check the rise and fall times for a 10 volt step signal. Risetime from 0.1 to 10 volts is typically 0.2  $\mu$ s, while falltime from 10 to 0.1 volt is typically 0.3  $\mu$ s.

Connect a 25-kHz square-wave signal from the Type 105 through a 50  $\Omega$  coaxial cable, and a 50  $\Omega$  termination to the Log Adapter INPUT connector.

Signal Amplitude	Minimum Apparent Bandwidth	
	-30%	-70%
100 mV Peak (200 mV p-p)	400 kHz	750 kHz
1 V peak (2 V p-p)	700 kHz	1.1 MHz
2.5 V peak (5 V p-p)	700 kHz	1.1 MHz
5 V peak (10 V p-p)	1.1 MHz	2 MHz

NOTE

If a Type 190A Attenuator head is used, the output connector must have a 50 Ω termination connected to it throughout the following checks. The Type 190B Attenuator does not need the 50 Ω termination.

Set the Operational Amplifier Volts/CM switch to .2 and connect the Type 190 Attenuator head to the Log Adapter INPUT connector.

Set the Type 190 Range Selector switch to 50 kHz and adjust the Output Amplitude and the Attenuator head switch to obtain exactly a 5-volt peak-to-peak signal.

Adjust the Operational Amplifier Variable control until exactly a 4-cm high signal is displayed.

Change the Type 190 Range Selector switch and Range In Megacycles control until a display amplitude of 2.8 cm is obtained on the test oscilloscope (do not readjust either the Type 190 Output Amplitude control or the Operational Amplifier Variable control).

Check the appropriate scale of the Type 190 Range In Megacycles control to obtain the apparent bandwidth of the Log Adapter. Using the procedure outlined above, the apparent bandwidth should be at least 700 kHz.

Change the Log Adapter AC-DC switch to DC and repeat the steps above. The apparent bandwidth should be at least 700 kHz.

Disconnect the Type 190 from the Log Adapter INPUT connector. This completes the Calibration Procedure.

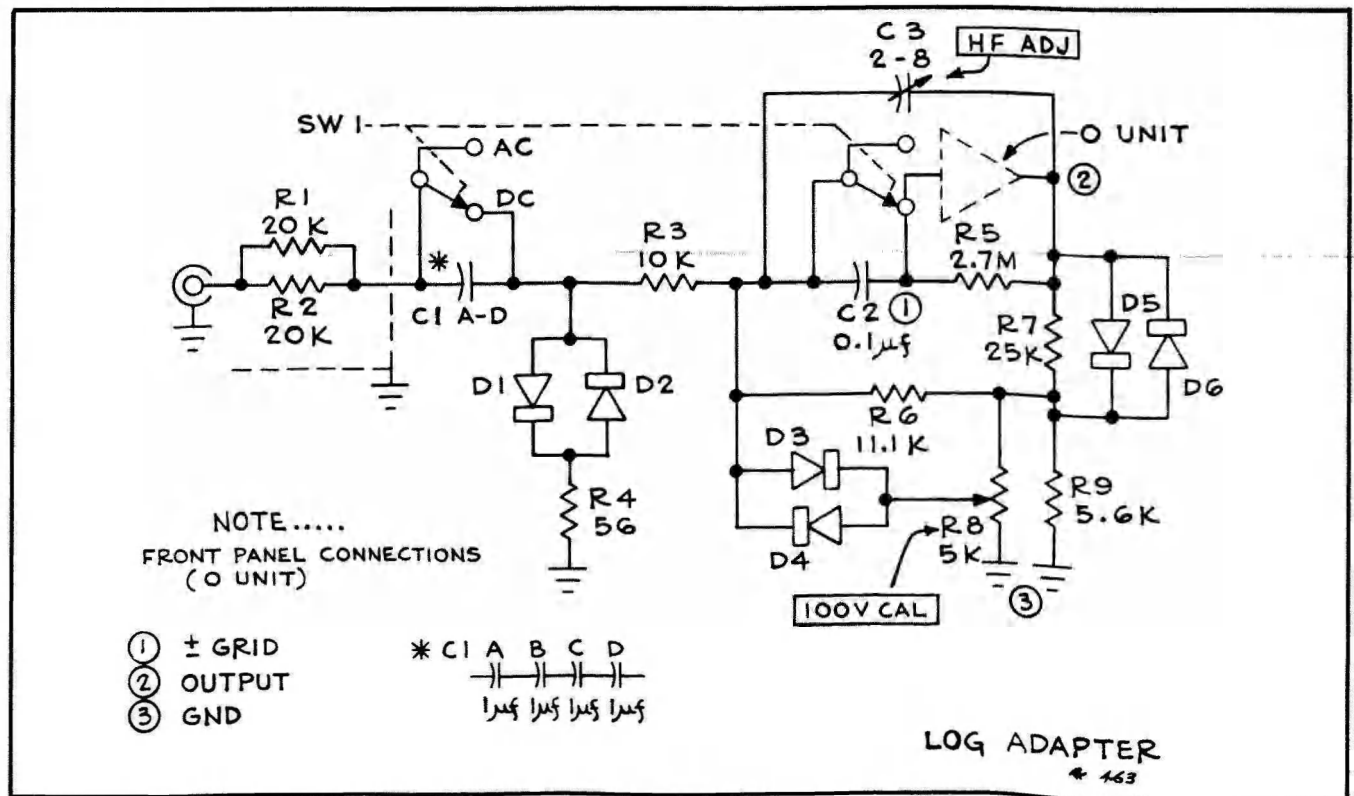
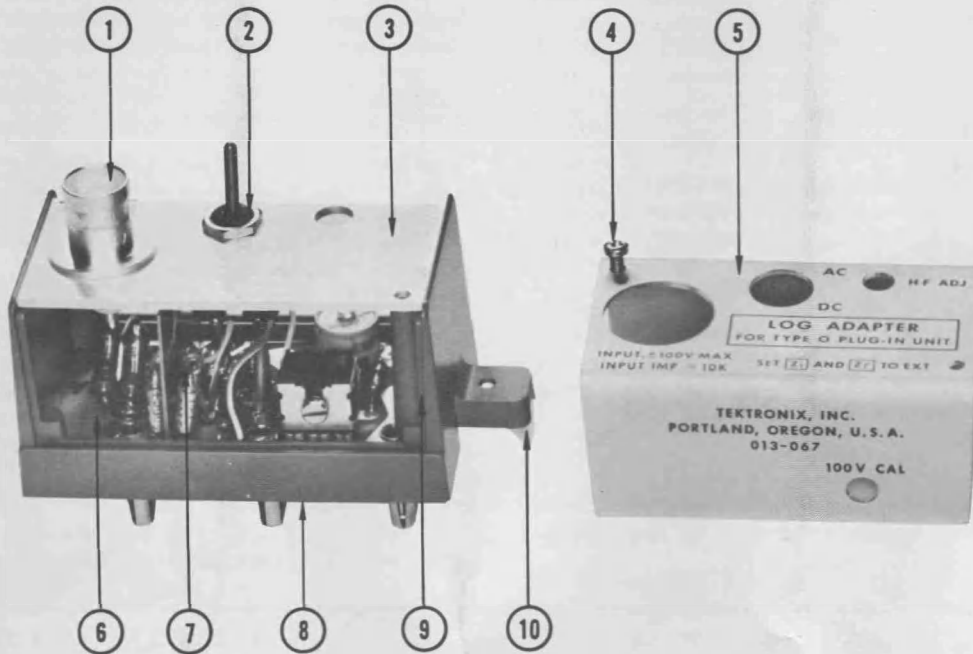

Fig. 4. Log Adapter Schematic.

## LOG ADAPTER PARTS LIST



REF. NO.	PART NO.	SERIAL NO.		QTY.	DESCRIPTION
		EFF.	DISC.		
1.	131-126			1	CONNECTOR
2.	260-511			1	SWITCH
	210-562			2	NUT, hex $\frac{1}{4}$ -40 x $\frac{5}{16}$
3.	387-739			1	PLATE
4.	211-079			4	SCREW, 2-56 x $\frac{3}{16}$ PHS slotted
5.	200-457			1	COVER
6.	388-545			1	BOARD, etched circuit
7.	337-565			1	SHIELD
8.	392-146			1	BOARD (not shown)
	211-095			2	SCREW, 2-56 x $\frac{5}{16}$ FHS slotted, 80° (not shown)
	134-070			1	PLUG (not shown)
9.	204-163			1	BODY
10.	401-022			1	CAM
	213-055			1	Mounting Hardware: (not included)
	309-392			1	SCREW, thread cutting, 2-56 x $\frac{3}{16}$ PHS
	318-084			2	R1-R2 RESISTOR, 20 k, $\frac{1}{2}$ w, prec, 1%
	315-560			1	R3 RESISTOR, 10 k, $\frac{1}{8}$ w, prec, 1%
	316-275			1	R4 RESISTOR, 56 $\Omega$ $\frac{1}{4}$ w, comp, 5%
	318-003			1	R5 RESISTOR, 2.7 meg, $\frac{1}{4}$ w, comp, 10%
	318-012			1	R6 RESISTOR, 11.1 k, $\frac{1}{8}$ w, prec, 1%
	311-359			1	R7 RESISTOR, 25 k, $\frac{1}{8}$ w, prec, 1%
	315-562			1	R8 POTENTIOMETER, 5 k, var. 20%
	290-177			1	R9 RESISTOR, 5.6 k, $\frac{1}{4}$ w, comp, 5%
	283-023			4	C1A-D CAPACITOR, 1 $\mu$ f, 50 v, EMT, 20%
	281-060			1	C2 CAPACITOR, .1 $\mu$ f, 10 v disc type
	152-110			1	C3 CAPACITOR, 2-8 pf, cer, var.
	152-109			1	D1-D2 DIODE, matched pair coded 6110
	152-111			1	D3-D4 DIODE, matched pair coded 6109
				1	D5-D6 DIODE, matched pair coded 6111